



# Video Images

Milwaukee - Madison - Green Bay - Minneapolis . . . and growing

# INDEX

AC Adaptors	225	Color Picture Monitors	59,156-159,220,239,240	Kloss Video Corporation	116
Accessories, Powerbelts/Paks	25		251,252	Knox Ltd	117
AMP Specialist Industries	2	Color Sync Distribution	216		
Amplifiers, Audio	192	Color Sync Generator	121,161,216,248	Laird Telemedia	119-121
Amplifiers, Line Extender	17	Color TV	228,234	Lamps, Studio and Stage (Replacement)	125-128,233
Amplifiers, Signal Distribution	17	Color TV Cameras	99,100	Leader, Splicing and Cueing Tapes	198
Antennas, Earth Station	200	Color TV Projection Systems	159	Learay Industries	122
Anvil Cases	3	Communication Systems	193	Lenses	30,119,120,141,146,162,168,169
Atlas Sound	4	Comprehensive Video Supply	27		187-189,203
Audio Accessories	27	Computerized Interactive TV System	66	Lenses, Projection	120,232,234
Audio Amplifiers	34,192	Consoles, Audio Production	14,92	Light Control Media	125-128,194,256
Audio Cassette Tape (Blank)	199	Continuous Loop Film Units	234	Light Diffusion Media	125-128
Audio Compressor/Limiters	245	Convergence	28,29	Light Stands, Hangers and Other	
Audio Consoles, (Wired)	14,92,185,186	Cosmicar	30	Gaffers Misc.	125-128,211
Audio Equalizers	244	Crosspoint Latch	31-33	Lighting Controls, Studio	114-115
Audio Filters	244	Crown International	34	Lighting Fixtures, TV	114,125-128,210,211
Audio Mixers/Preamplifiers	14,32,185,192	CRT Displays	41	Lighting Kits, TV	125-128,210,211
Audio Production Consoles (Wired)	92	Cue Systems	121,178	Lighting Packages, Complete Studio	114
Audio Program Monitor	253			Lights, Base and Fill	112
Audio Sibilance Controllers	142	Datametrics	35,36	Lights, Key and Back	113
Audio Stereo Synthesizer	142	Datron Inc.	37,38	Lights, Portable	26,211
Audio Tape	198,199	Demodulators, TV	110,201	Listec/Vinten TV Equipment Corp.	123,124
Audiotronics Video Display Division	5	Digital Clocks/Timers	45	Location Lighting Equipment	210,211
Audio-Video TV Demodulators	110	Direct Boxes	246	Loudspeakers	50,246
Audio-Video TV Modulators	16,19,39,110	Distribution Equipment	17	Lowel-Light	125-128
Audio-Visual Tables, Carts and Stands	10	Dollies, Cameras	95,98,124,182	Luxor	129,130
Audio-Visual/TV/VTR Centers	10,254	Dynair	39	LW International (Athena)	118
Auto-Light Controls for Film Islands	119				
Automatic Video Teleconference System	136	E. S. E.	44,45	Master Control Automation Systems	89,90
Automation Control Equipment	52	Eckstein Bros. Inc.	62	Matthey	131
		Editing Consoles (Furniture)	254,255	Message/News Display Systems	8,9
Ball Electronics, Display Division	6	Editing Control Systems and Associated		Microphone Accessories	4,51,166
Batteries	22,146,225	Accessories (Video Tape)	28,29,104,106	Microphone Amplifiers	65
Battery Chargers	21-23,146		143,150-152	Microphone Cable	51,225
Battery Systems	26	Edutron	64	Microphone Mixers	65,185,205,227
Belden Wire	7	Electro-Voice	46-51	Microphone Stands and Booms	4,51
Beston	8,9	Electrohome	40,41	Microphones	46-49,141,166,206,207,226
Billboard Generator, Color	121	EMI Inc.	42	Microphones, Wireless	20,81,82,84
Blonder-Tongue	15-18	ENG Carts	68	Microtime	132,133
Brackets, TV	167	Envelope Delay Filter	39	Misar	136
Bretford	10-12	Equalizer, Audio	142	Mixers, Audio	14,92,166,192,205,227
Broadcast Electronics	13,14	Equipment Cases	3,62	3M-Video Products	134,135
Burst-Phase Meter	248	Equipto Electronics Corp.	43	Mobile AV/TV Tables, Stands and Carts	10,11,68
				Mobile AV/TV/VTR Centers	254
Cabinet Accessories	231	Fernseh Inc.	52-61	Modular Distribution System	209
Cabinets, Consoles, Racks and Enclosures		Film Chain Light Level Controls	119	Modulators/Converters TV	19,39,110
(For Equipment)	43,229,230,254,255	Film Chains	119	Monitor Amplifier	65
Cable and Wire	7	Filters, Single Channel	18	Monitor Mounts	42,172,257-260
Camera Accessories	61,101,111,148,163,203	Folding Mobile Carts	68	Monitor Speakers	50,65,246
Camera Cable	7,61,141,146,163	Folding Tables	68	Monitor, TV Picture, Color	33,59,108,109
Camera Enclosures/Housings	42,171,172	FOR-A	63	137,156-159,219,220,239,240,251,252	5,6,33
Camera Mounting Accessories	42,163,172	Frame Synchronizer	132,133	Monitor, TV Picture, Monochrome	80,235,236
Camera Pickup Tubes	61			Monochrome TV Monitor	5,6,33,160,220
Camera Support Equipment	42,94-98,123,124	Generators, Black Burst	249	Multi-Signal Distributor	119,216
	139-141,182	Generators, Character	8,9,60,117,121,134,181	Multiplexer Optical	119,256
Camera Wall/Ceiling Mounting Brackets	42	Generators, Color Bar	32,56	NEC America	137,138
Cameras TV, Color Portable	73-75,77,79,99-101	Generators, Cross Pulse	248	Noise Meter, Video	178
	141,144,146-148,218,222-224	Generators, Sync	55,121,161,216	Noise Reduction Systems	58
Cameras TV, Color, Studio	73,77,78,99,100,146	Generators, Time Code/Reader	28,29,35,36,38	O'Connor Engineering Labs	139,140
Cameras, Color TV Medical	76	Generators, Video Special Effects	161,204,216	Orban	142
Cameras, TV, B/W, Surveillance	149,162,187-189	Gentech	66	Oscilloscopes	80
Cameras, Broadcast Color, ENG/EFP	73-75,143	GKC	65		
	145-147,203	Graphics Systems, Video	179-181	Pan/Tilt/Scanner Units and Controls	42,164
Cameras, Broadcast Color, Film Chain	61	Grass Valley	67	170,172,175,176	
Cameras, Broadcast Color, Studio	73,77,146,203	Gruber Products (Wheelit)	68	Panasonic Video Systems Div.	143-166
Carriers, Video Equipment	122			Parabolic Sound Reflector	227
Carrying Cases	111	Hanger System	195	Patch Cords and Patch Panels, Video	242
Carrying Cases (Equipment)	62,111,125-128	Head Cleaning Cassette, Video	141	Pedestals, Camera	94,98,124,139
Carrying Equipment, Portable Video	111	Head Cleaning Cassette, Audio	198	Peerless	167
Carts, TV	167	Head Cleaning Cassette, Video	221	Pelco	168-176
Cases for Tripods and Lightstands	111	Headend Equipment	18	Porta-Brace	111
Cases, Storage-Carrying and Shipping	3,62,111	Headphones	241	Porta-Pattern	177
	125-128	Heads, Camera	97,98,140,182	Power Amplifiers	246
Cassette Albums and Storage Units	195,221	Helical Video Tape	196	Power Belts/Paks	21,23,25,26
Cassettes, Audio	199	Hitachi-Denshi	69-80	Power Cables	125-128
Catel	19	HME	81-84	Power Supplies	51
Cetec Vega	20	Image Enhancer	132	Processing Equipment, Video	58
Channel Converters	18	Industrial Sciences, Inc. (ISI)	85-93	Production Switchers, Video	31-33,86,88,93,216
Character Generator	8,9,35,36,60,117,121	Innovative TV Equipment	94-98	Programmers	44,63
	134,181,204			Projection Lenses	232,234
Christie	21-23	Insertor Program	133	Projection TV, Color	116,159
Chroma Keys	32,161	Intercom Systems	191,193,249	Projectors, 16mm	118
Cine 60	25,26			Projectors, Film TV	120
Cinema Products Corp.	24	Jerrold (Taco/Jerrold)	110	Projectors, Slide TV	120,232
Clocks/Timers	44	JVC	99-109	Projectors, Slide/Dissolve	232
Coaxial Cable and Accessories	2,7				
Color Encoder	56	K&H	111		
Color Phase Shifter	218	Kings Electronics	2		
Color Picture Monitor/Receivers	108,109,251	Kliegl	112-115		

Projectors, Sound-Slide	234	Stereo Synthesizer	142	Vectorscopes	237,238,250
Projectors, Super 8mm	234	Storage Cabinets	12	Vicon	247
Projectors, Video Film	120	Storage, Tape and Film	255	Video Accessories	27,85,87,93,164,225,249
Projectors, Videoslides	120	Studio Lighting Equipment	114	Video Activated Power Switch	249
Prompting Systems	24	Studio Quartz Lamps	233	Video Aids of Colorado	248,249
Pulse and Blanking Delay Box	131	Sun Gun Kits	26	Video Cabinets/Consoles (For Equipment)	10,12
Q Board	121	Super-Density Storage	255	Video Cable	7,225
Q-TV	178	Surge Protectors, Power	10	Video Carts and Tables	10,68,257-260
Quick-Set	182	Switchers, Audio	54	Videocassette Players	103,104,107,138,143
		Switchers, Master Control	89		151,153-155,213-215
<b>RAMSA (Panasonic)</b>	<b>183-186</b>	Switchers, Video	39,54,89,162,173,174	Videocassette Recorders	102,103,105-107
<b>RCA CCTV</b>	<b>187-189</b>	Switchers, Video Production	31-33,85-89,91,93		138,141,143,151,153-155,212-215,218,234
Rear Projection Screen Viewers	234	Switching	57	Videocassette Recorders, Time Lapse	153
Rear Screen Projection Systems	234	Sync and Distribution Equipment	208	Videocassettes (Blank Recording)	141,221
Recorder Camera	143	Sync Changeover	67	Video Character Generators	8,9,60,117,121,204
Recorders, Audio Cartridge	13	Sync Generators, Video	33,67,121	Video Consoles/Cabinets (For Equipment)	130,254,255,257-260
Recorders, Videocassette	102,103,105-107,138	System Concepts	179-181		
	143,151,153,155,212-214,218,234	System Delay Module	131	Video Delay Boxes	131
Recorders, Videocassette, Time Lapse	153	Tables	11,129	Video Delay Lines	131
Recorders, Video Helical	69-72	Tape Accessories	225	Video Distribution Amplifiers	39
Recording Tape Audio, Cassettes	199	Tape and Film Storage	255	Video Editing Systems	28,29,37,104,143,152
Recording Tape Audio, Open Reel	198	Tape Recorders	72	Video Effects Generators	216
Recording Tape Video, Accessories	221	Technicolor	234	Video Encoders, Color	56
Recording Tape Video, Cartridge	221	Tektronix	235-240	Video Equipment Rental	190
Recording Tape Video, Cassette	141,221	Telecine Projectors	120	Video Film Projectors	120
Recording Tape Video, Open Reel	221	Television, Worldwide 4 System Color	219	Video Image Enhancers	132
Reels and Packaging, Tape	195,198,221	Telex (Broadcast)	241	Video Image Processor	132
Remote Control Equipment	104,164	Terminal Equipment	55,57,93	Video Motion Analyzer	153
Rental Equipment Rate Sheet	190	Test Equipment	246,248	Video Patch Panels and Cords	242
Rental, Video Equipment	190	Time Base Correctors	64,132	Video Picture Corrector	132
Reverberation Equipment	142	Time/Date Generators	121	Video Picture Monitors, Color	41,59,108,109
Rosco	194	Titling Systems	8,9,117,121,134,179-181		156-159,219,220,251,252
Routing Switchers	32,54,135	Tone Arms	183	Video Picture Monitors, Monochrome	5,41,79
<b>RTS Systems</b>	<b>191-193</b>	Towers, AM, FM, TV, Microwave	243	Video Processing Systems	58,67,132
		Transformers, Audio	142	Video Production Switchers	85-89,91,93,204,216
Sanyo	141	Tripods, Camera	96,98,139-141,182	Video Projection, Large Screen	40
Satellite Earth Station Equipment and Accessories	15,200-202	Tripods, Pedestals, Dollies, Heads, Camera	94-98,123,124,139,140,182	Video Prompter System	178
Scanners	170,176	Trompeter	242	Video Responder	217
Scientific Atlanta	200-202	Tuner/Timer	137,218	Video Responder Interactive Learning System	165,217
Scotch 3M	195	Tuners, VHF/UHF TV Audio	228	Video Signal Processor	132,201
Scotch Audio Tape (3M)	198,199	Turntables and Bases	183	Video Signal Synchronizers	132
Scotch Video Tape (3M)	196,197	TV Camera Lenses	30,141,146,187-189	Video Special Effects Generators	161,198,204,216
Security and Surveillance Equipment	247	TV Demodulators	201	Video Switchers	39,54,162
Sharp Electronics	203	TV Modulators	19,39,110,201	Video Sync Generators	33,55,67
Shintron	204	TV Monitor/Receivers, Color	41,137,219,220,253	Video System Delay Modules	56
Shipping Cases/(Equipment)	3,62	TV Monitors, Color	59,137,219,220,239,240	Video Tape (Blank Recording)	141,196,197
Shipping Containers/Mailers (Film and Tape)	198	TV Monitors, Monochrome	5,6	Video Tape Accessories	27
Shure	205-207	TV Multiplexer, Optical	256	Video Tape Editing Control Systems and Associated Accessories	28,29,37
Sibilance Controller	142	TV Projectors, Film	120	Video Tape Recorders (Open Reel)	69-71
Sigma	208,209	TV Projectors, Slide	120	Video Test Charts, Films, Slides and Transparencies	119
Slide Dissolve Equipment	232	TV Receivers, Color	228,234	Video Time Base Correctors	64
Slide/Dissolve Projectors	232	TV Stands	10,167	Video Squelch	248
Smith-Victor	210,211	TV Tables	10,129	Videotek	250-253
SMPTTE Time Code Control Systems	28,29,35,36,38	TV Test Chart Systems	177	Videotypewriter	63,204
Sony Corp. of America	212-228	TV Waveform Monitors	235,236	Vidicons	61
Soundolier	229-231	TV Channel Converters	18	Waveform Monitors	80,235,236,250
Speaker Components	228	TV Signal Amplifiers	17,18	H. Wilson (Insert)	257-260
Speakers	184,246	TV Signal Modulator	16	Winsted	254,255
Special Effects Generators, Video	204,216	Unarco/Rohn	243	Wireless Intercom Systems	83
Spindler and Sauppe'	232	Unplexers, Opt cal	119	Wireless Microphones	20,81,82,84
Splicing Kit	198,221	UREI (United Recording Elec. Inc.)	244-246		
Splicing Tape	198	Vari-Flex Modular Headends	18	Zeimark	256
Splitter Combiner	18				
Stands, TV	167				

# Video Images

12200 West Adler  
Milwaukee, WI 53214  
(414) 475-0111

811 Mayfair Avenue  
Madison, WI 53714  
(608) 241-5281

9909 Valley View Road  
Minneapolis, MN 55344  
(612) 941-9267

PO Box 3855  
Green Bay, WI 54303  
(414) 822-5975

And Growing . . .



**CRIMP TYPE COAXIAL CONNECTORS**

CABLE TYPE	CONNECTOR TYPE	CONNECTOR NUMBER	100-LOT UNIT PRICE	CRIMP TOOL NUMBER	CRIMP TOOL UNIT PRICE	CRIMP DIE NUMBER	CRIMP DIE UNIT PRICE
RG-59	UHF	2-330830-6	\$4.65	69710	\$300.00	220036-1	\$185.00
RG-59	BNC	331350	\$2.50	69477-1	\$185.00	Integral	—
8281	UHF	2-330830-2	\$4.65	69710	\$300.00	220037-1	\$185.00
8281	BNC	4-331350-0	\$2.95	220043-1	\$260.00	Integral	—

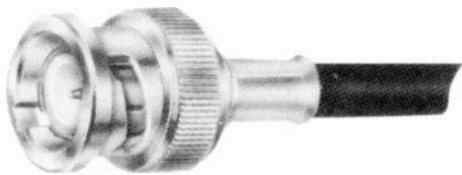

**BNC/RG59**



**UHF/RG59**



**CRIMP  
TOOL**

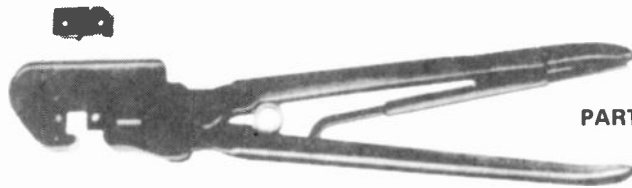

**PART NO. 69710**

**KINGS ELECTRONICS**

**CRIMP TYPE TRIAX CONNECTORS**

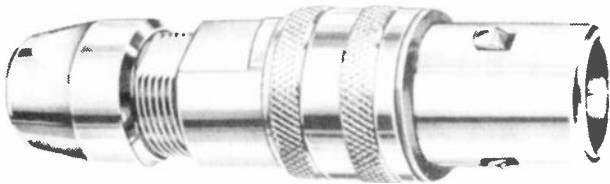

**TRI-LOC PLUGS**

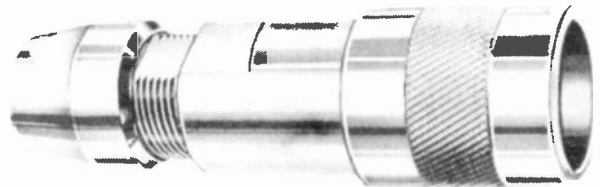

**JACKS**

**TRI-LOC CABLE SPECIFICATION CHART**

CABLE	CABLE GROUP	NOMINAL CABLE DIMENSIONS						KINGS PART NO.	DESCRIP- TION	FIG. NO.	CRIMP DIE NO.	DIELEC- TRIC TRIM JIGS	JACKET TRIM JIGS
		CENTER CONDUCTOR O.D.	CORE O.D.	INNER BRAID O.D.	INNER JACKET O.D.	OUTER BRAID O.D.	OUTER JACKET O.D.						
BELDEN 9232 BW 10070-C-G14	740	14 AWG STRANDED 074	312 FOAM PE	342	392 PE	422	520 NEOP	KP8010-740-400	PLUG	1	KTH-2041	KTD-304	KTJ-300
								KP8010-740-401	JACK	2			
BELDEN 8233	700	14 AWG SOLID 064	285 FOAM PE	315	365 PE	395	475 PE	KP8010-700-400	PLUG	1	KTH-2040	KTD-300	KTJ-300
								KP8010-700-401	JACK	2			
BELDEN 9267 BW 10069-C-G20	730	20 AWG SOLID 032	146	176	216 PE	250	360 NEOP	KP8010-730-400	PLUG	1	KTH-2002	KTD-303	KTJ-303
								KP8010-730-401	JACK	2			
BELDEN 8232	760	20 AWG SOLID 032	± .004 143 FOAM PE	.176	± .005 226 PE	256	± .007 315 PE	KP8010-760-400	PLUG	1	KTH-2002	KTD-303	KTJ-303
								KP8010-760-401	JACK	2			
FELTEN AND GUILLEAUME 2.1 LS/10S	770	STRANDED .087	± .004 .382 FOAM PE	418	± .008 .456	± .008 490	± .008 .567	KP8010-770-400	PLUG	1	KTH-2104	KTD-307	KTJ-300
								KP8010-770-401	JACK	2			

Note: TRI-LOC Connectors are available to terminate conventional coaxial cables such as RG-59/U and Belden 8281. Consult factory for information.

Note: Use CRIMP TOOL No. KTH-1000.  
Note: Part numbers ending in 400 indicate plugs with Safety Tip.  
Part numbers ending in 401 without Safety Tip.

Price: All Connectors listed above — \$120.00 each.

Prices and Specifications Subject to Change Without Notice.

**Protect your A/V and Video investment with the strength of ANVIL Cases!**

If your equipment is constantly on the road—or in the air—rugged, dependable ANVIL cases will make sure it arrives in performance-ready condition every time

ANVIL cases have been on tour with everyone from top rock bands to the Super Bowl Champs for years. They can't afford to miss a performance. If you can't afford to miss a performance you should protect your equipment with ANVIL quality too.

We can custom-build cases to fit any A/V or Video product on the market. And we can design your case to carry those all-important cords, cables and connectors right with your unit!

ANVIL ATA cases conform to rigid Airline Transport Association specs.



**CAMERA CASES.** Without a doubt, cameras are the most delicate and easily damaged of all video products. Keep your camera safe and vital interface components at hand in an ANVIL case.



**RECORDER CASES.** The ever-increasing demand for remote, field recording has increased the possibility of damage to delicate alignment and calibration adjustments during transit.



**COMBINATION CAMERA/RECORDER CASES.** Now any manufacturer's camera can be safely transported with any recording unit. Once on location, just open the case—hook up—and shoot!

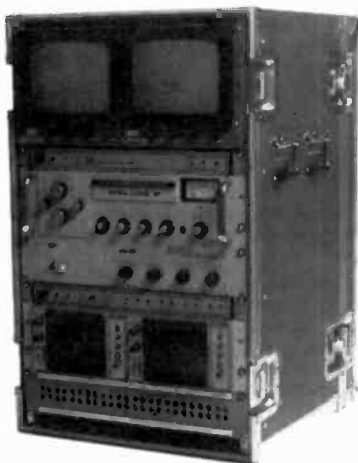

**E.I.A. RACKMOUNT CASES.** Standard 19 inch rackmount configurations can be safely and easily moved to your location—shoot—ready! Front and back covers remove to provide full access to controls and connections. Adequate ventilation for proper equipment operation is designed into the case.

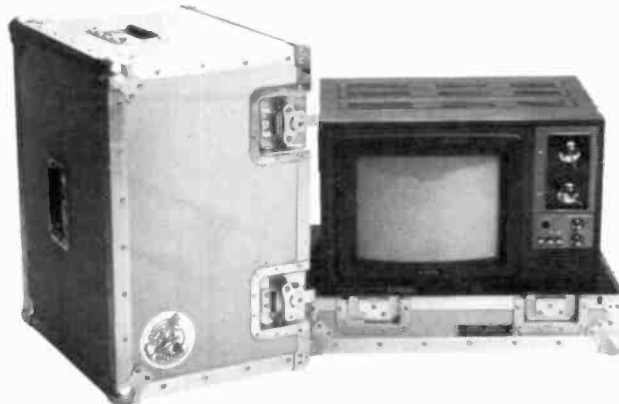

**MONITOR CASES.** Your delicate video monitor is gently but firmly suspended in high-density polyfoam sculptured to exact dimensions. The foam core is supported by top-grade wood and impact-resistant ABS plastic walls riveted to a rugged aluminum frame.

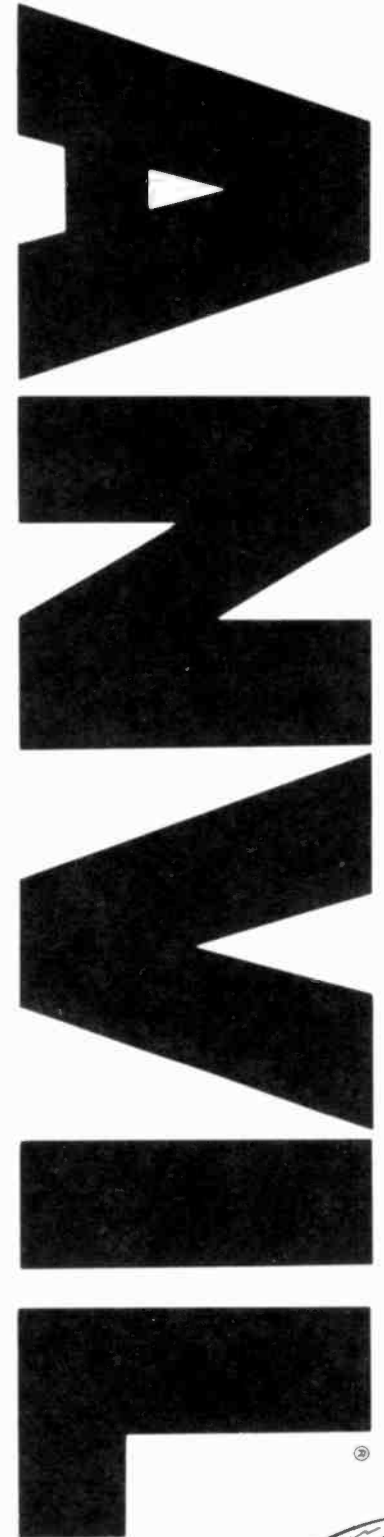



# ATLAS SOUND

Microphone  
Stands and  
Accessories

## "MICROPHONE FLOOR STANDS"



MS-10C \$30.00

The world's most popular, budget-priced microphone floor stand. 5/8"-27 standard microphone threads. Grip-action clutch, 10" dia., circular base, charcoal finish. 35" to 63" H., 10 lbs.

PS-C \$44.15  
PS-C3 50.85

Porta-Series. Functional and foldable. Designed for the touring performer. Unique spring-lock tripod base reduces to 32" H. minimum for transport and storage. PS-C3; with 3-section tube for miking at low height. PS-C; 35" to 63" H., 4.5 lbs. PS-C3; 26" to 66" H., 4 lbs.

MS-11S \$74.60  
MS-12S 69.15

The Professional's favorite. Automatic sleeve action clutch for effortless instantaneous height adjustment. Low silhouette, circular base. MS-11S; with decorative chrome base-cover. 39" to 62" H., MS-11S; 13 lbs. MS-12S; 12 lbs.

MS-11C \$35.70  
MS-12C 30.00  
MS-14G

Versatile general purpose floor stands featuring grip-action clutch, and low profile, 10" dia. base with added weight for stability. MS-11C; chrome finish base. MS-12C; texture charcoal base. MS-14G; tube assembly and base cover in decor gold. 34" to 62" H., 12 lbs.

MS-4 \$44.15  
MS-20 46.65

Professional stands, with grip-action clutch. Low contour circular base provides heavy duty stability required for stage, or use with boom attachment. MS-4; 3 section 25" to 65" H., 11 lbs. low height option. MS-20; 37" to 66" H., 14 lbs.

PS-S \$94.30

The artists choice. Combines the compact, foldable advantage of the Porta-series stands with our unique easy-adjust automatic sleeve action clutch. 39" to 62" H., 6.5 lbs.

MS-25 \$82.20

Professional studio stand. Air suspension system for microphone protection. Over-size 11-1/8" dia. tube assembly and extra heavy 17" triangular base with chrome cover for maximum stability. 38"-67" H., 23 lbs.

## "MICROPHONE BOOM ATTACHMENTS"



PB-1 \$26.40  
PB-1X 34.15

Porta-Boom, with maximum functional and operational flexibility. Professional appearance, rugged construction. Attaches to any stand terminating in 5/8" dia. tubing. Cast iron tapered counterweight, easy-grip, decorative hardware. PB-1; 31" L., 5 lbs; PB-1X; expandable from 31" to 50" L., 6 lbs.



BB-44 \$20.70

One-piece universal microphone boom attachment. Controls motion and position with a single triangular knob. Charcoal texture finish counterweight for balance. 31" L., 3 lbs.



PB-2X \$31.25

Expandable boom attachment for hand held use or stand attachment. Grip-action clutch control for length adjustment from 21" to 37" L., 2.5 lbs.

## "LOUDSPEAKER STANDS"

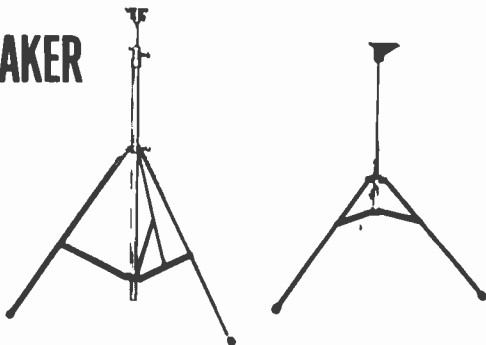

SS-2  
CSS-100

The fully portable support stands to elevate loudspeaker cabinets, PA horns, sound columns, etc. For indoor or outdoor use. SS-2; vertical adjustments from 60" to 120" H., base spread 48"-60", 20 lbs. CSS-100; 42" H., single tube design, stationary height. Base spread 40", 14 lbs.

## "STUDIO BOOMS"

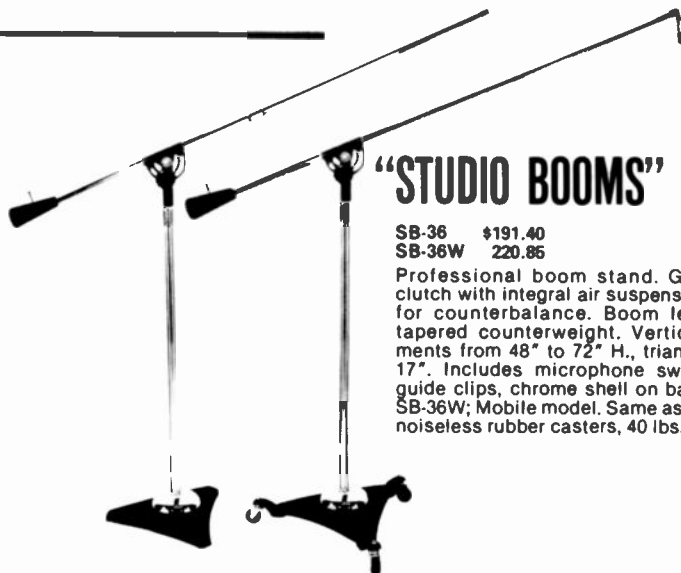

SB-36 \$191.40  
SB-36W 220.85

Professional boom stand. Grip-action clutch with integral air suspension system for counterbalance. Boom length 62", tapered counterweight. Vertical adjustments from 48" to 72" H., triangular base 17". Includes microphone swivel, cable guide clips, chrome shell on base, 36 lbs. SB-36W; Mobile model. Same as SB-36 with noiseless rubber casters, 40 lbs.

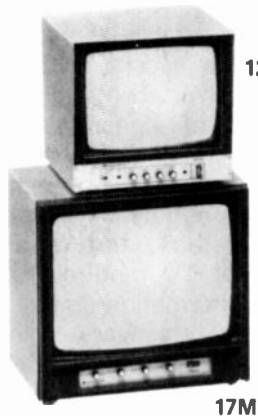
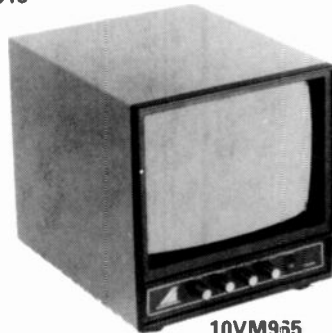
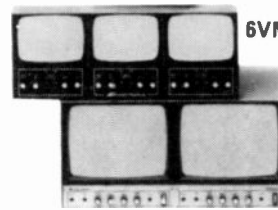
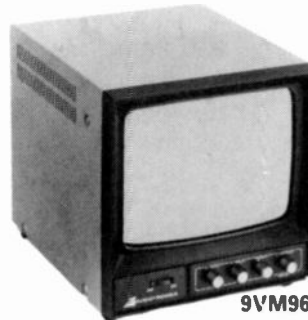
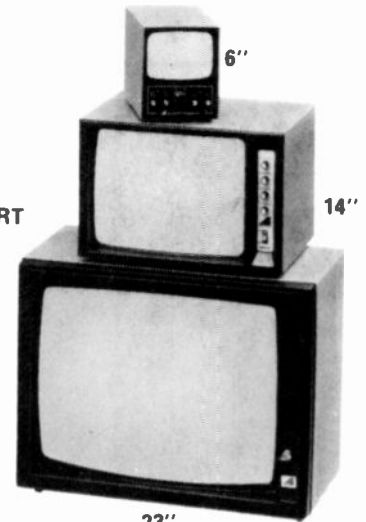
**12M918**
**17M**

**10VM955**

**6VM917T**
**10VM965RT**

**9VM967**

**6"**
**14"**
**23"**
**6VM917**

Professional 6-inch American-made monitor features a 600-line horizontal resolution, 100% solid-state circuitry; compact desktop, rack mount or console mount design; easily replaced regulator and deflection transistors; readily accessible components; rigidly constructed frame with easy-to-remove chassis assembly. Inter-compartment shielding prevents cross-talk; coaxial connectors mounted at 60-degree angle; front-mounted major controls and adjustments; and external sync provisions. Metal cabinet. 7" x 5-7/8" x 10-7/8". 8-3/4 lbs. **\$325.00**

**6VM917C**

Without metal cabinet. **\$315.00**

**6VM917T**

Triple-six monitor. Three 6-inch monitors (see above) in a row with rack/desk top metal cabinet. 7" x 17-1/4" x 10-7/8". 28 lbs. **\$925.00**

**9VM967**

Low price, general purpose 9-inch monitor features 700 line horizontal resolution, convenient up-front operating controls, simplified service adjustments and time lapse VTR capability. Heavy duty single chassis construction. 8-3/4" x 8-3/4" x 10-1/4". 16 lbs. **\$175.00**

**10VM965**

Modestly-priced 10-inch monitor features 100% solid-state circuitry, 800-line horizontal resolution, front-access to key controls; screwdriver adjustments for vertical linearity, height and focus; regulated power supply, and fast AFC circuit for excellent scan VTR display. Rear panel controls and connectors: 75-ohm termination for video input, BNC connectors for video input and looping, AC fuse, and optional sync selector switch. Metal cabinet. 8-3/4" x 8-5/8" x 10-5/8". 14 lbs. **\$250.00**

**10VM965C**

Without metal cabinet **\$240.00**

**10VM965RT**

Dual ten monitor. Two 10-inch monitors (see above) in a row with rack/desk top metal cabinet. 8-3/4" x 17-1/4" x 10-5/8". 25 lbs. **\$525.00**

**12VM918**

Broadcast quality 12-inch video unit features UNIT-IZED plug-in circuit modules for rapid, on-the-spot maintenance; 100% solid-state circuitry; compact design, with attractive lightblue finish; front-

mounted major controls; convenient front-panel screwdriver adjustments for vertical linearity, height and focus; regulated power supply, and a fast AFC circuit for superior quality VTR display. Rear panel controls and connectors: 75-ohm termination switch for video input, BNC connectors for video input and looping, AC fuse, and optional sync selector switch. Metal cabinet. 11-3/8" x 12-1/8" x 12-1/8". 21 lbs. **\$360.00**

**12VM918C**

Without metal cabinet **\$350.00**

**14VM939**

The 14-inch screen offers top picture quality, solid-state reliability, and unitized construction at modest cost. Styling is attractive, with shadow blue finish and aluminum control panels. Key features are: 100% solid-state circuitry, except for CRT; 800-line (or better) resolution; front-panel operating controls; regulated power supply; VTR compatibility; plug-in module incorporation of major components; CRT bleeder discharge system, and switchable D.C. restoration. The unit complies with federal rules governing X-radiation. Metal cabinet. 10-1/2" x 15-5/8" x 12-7/8". 29 lbs. **\$475.00**

**17VM922**

The 17-inch model features silicon 100% solid-state circuitry (except CRT) for maximum performance stability, long life reliability and low power drain and heat; 800-line (or better) resolution, front-panel operating controls, regulated power supply to counteract power line fluctuations, and fast AFC action for optimum VTR operation. The model also includes bleeder discharge systems for CRT, and black porch clamp DC restoration. All major components incorporated in plug-in modules for ease of maintenance and minimum down time. Metal cabinet. 15-1/2" x 16-1/4" x 11-7/8". 33 lbs. **\$505.00**

**23VM952**

The 23-inch CRT display monitor features front "slide out circuitry" for reduced down time and instant on-the-spot servicing and also permits in-the-wall installation in areas where rear access is impossible. Silicon 100% solid-state circuitry provides maximum performance and stability, long life reliability and low power drain and heat. All major controls are front mounted for easy access and operation. Power supply is regulated to prevent raster size or brightness deviation due to line voltage fluctuations. The monitor features a superior gray scale and VTR capability. 17-3/4" x 22-1/2" x 16-1/2". 60 lbs. **\$655.00**

**MONITOR OPTIONS:**

External Sync Provisions	<b>\$21.00</b>
Underscan Nonswitchable	<b>21.00</b>
Ceiling Yoke Adaptor (23M952 only)	<b>42.00</b>
Dual 9" Rack Mount	<b>30.00</b>
Rack Mount for 14VM939	<b>35.00</b>
Rack Mount for 17VM922	<b>35.00</b>

# MONITORS

## TD Series

The Ball TD Series of monochrome television monitors consists of high performance, high reliability, raster-scan displays which accept an EIA composite input. They are designed for quality display of alphanumeric dot characters, or TV camera video. These monitors are proven in such demanding uses as remote computer terminal data display, industrial CCTV, educational TV, and airline arrival/departure information display. TD Series monitors are available in 12-inch, 15-inch and 23-inch diagonal screen sizes. Each is contained in a rugged steel cabinet. They include modular construction and 100% solid-state silicon circuitry. P4 white phosphor is standard, with other EIA registered phosphors available. Other options include walnut wood grain vinyl-clad metal cabinet, choice of connector types, and special face-plates.

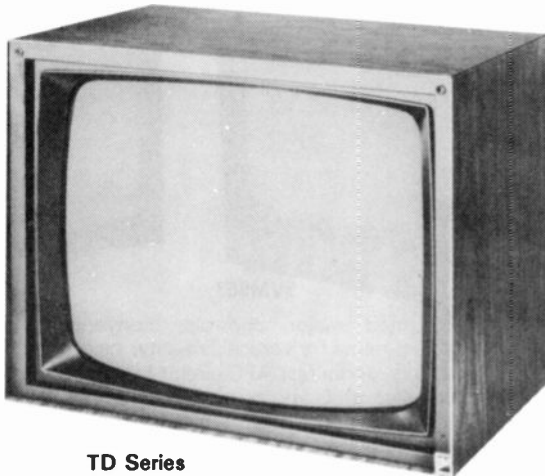

TD Series

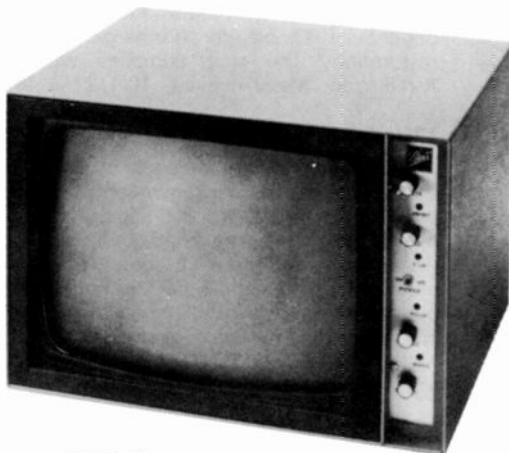

TE Series

## TE Series

The Ball TE Series black and white monitors are low cost, solid-state video monitors designed for utility applications in broadcast television, instructional television, visual information display and security television systems where reliability and high quality video reproduction are desired. The monitors feature either a 9-inch "T-banded" or a 12-inch "Shell bonded" cathode ray tube, with the remaining circuitry of solid-state construction.

### MONOCHROME — HIGH PERFORMANCE MONITORS FOR REMOTE DATA

TD12C Chassis only .....	\$480.00
TD12M Metal cabinet .....	535.00
TD15C Chassis only .....	510.00
TD15M Metal cabinet .....	565.00
TD23M Metal cabinet .....	620.00
Option: Ceiling mount for TD23M metal cabinet .....	62.00

### MONOCHROME — GENERAL PURPOSE MONITORS

TE9C Chassis only .....	\$440.00
TE9M Metal cabinet .....	485.00
TE9RT Twin units in rack mtg. ....	990.00
TE12C Chassis only .....	475.00
TE12M Metal cabinet .....	520.00
TE12R Rack mtg. ....	505.00



## Complete Catalog Available Upon Request

### 75 OHM PRECISION VIDEO CABLE

Trade & UL Type Number	AWG (Stranding) [Dia. in mm] Nom. D.C.R.	Nominal O.D.		Shield Coverage Nom. D.C.R.	Nom. Imp. (ohms)	Nom. Vel. of Prop.	Nominal Capacitance		Nominal Attenuation			Standard Lengths	
		Inch	mm				pF/ft.	pF/m	KHz or MHz	db/100 ft.	db/100 m	ft.	m
 <b>8281*</b>	20 (Solid) [.81] bare copper 9.9 Ω/M' 32.5 Ω/km	.304	7.72	96.4% 1.06 Ω/M' 3.5 Ω/km	75	66%	21	69	10 kHz	.06	.2	500,	152.4,
									100 kHz	.08	.3	1000	304.8
									1 MHz	.25	.8		
									4.5 MHz	.45	1.5		
									10 MHz	.78	2.6		
100 MHz	2.70	8.9											



*Conductor, polyethylene insulated, tinned copper double braid shield, black polyethylene jacket. Nom. Core O.D. .200" (5.08 mm).*

### CATV-MATV COAXIAL CABLES

Trade & UL Style NUMBER	AWG (Stranding) [Dia. in mm] Material and Nom. D.C.R.	Insulation Nom. Core O.D.		Shield Material and Nom. D.C.R.	Jacket	Nom. O.D.		Nom. Imp. Ohms	Nom. Vel. of Prop.	Nom. Cap.		Nominal Attenuation			Standard Lengths	
		Inch	mm			Inch	mm			pF/ft.	pF/m	MHz	db/100'	db/100m	ft.	m
 <b>8221</b>	22 (solid) [.64] bare copper covered steel 55.0 Ω/M' 180.5 Ω/km 100% SWEEP TESTED	.146	3.71	95% bare copper braid 2.6 Ω/M' 8.5 Ω/km	Gray, White, Black vinyl	.242	6.15	80	78%	16.3	53.5	50	2.1	6.9	100, 500,	30.5, 152.4,
												100	2.9	9.5	1000	304.8
												200	4.1	13.5	U-500,	U-152.4,
												500	6.6	21.7	U-1000	U-304.8
												900	8.8	28.9	(UNREEL)	(UNREEL)

Trade & UL Style Number	AWG (Stranding) [Dia. in mm] Material and Nom. D.C.R.	Insulation Nom. Core O.D.		Shield Material and Nom. D.C.R.	Jacket	Nom. O.D.		Nom. Imp. Ohms	Nom. Vel. of Prop.	Nom. Cap.		Nominal Attenuation			Standard Lengths	
		Inch	mm			Inch	mm			pF/ft.	pF/m	MHz	db/100'	db/100m	ft.	m
 <b>9248</b>	18 (solid) [.97] bare copper 7.5 Ω/M' 24.6 Ω/km 100% SWEEP TESTED	.180	4.57	Duofoil + 61% tinned copper braid 5.2 Ω/M' 17.1 Ω/km	Black vinyl	.270	6.86	75	78%	17.3	56.8	50	1.5	4.9	500, 1000	152.4, 304.8
												100	2.1	6.9		
												200	3.1	10.2		
												500	5.0	16.4		
												900	6.9	22.6		

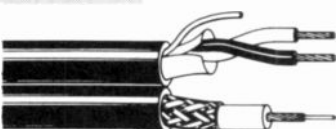
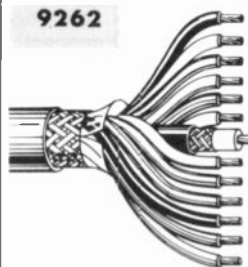
### MULTI-CONDUCTOR CABLES

<p><b>9265*</b></p>  <p><b>3-CONDUCTOR VIDEO, MONITOR AND SIGNAL CABLE</b></p> <p><b>Specifications:</b> 2-22 AWG (7x30) tinned copper, vinyl insulated, twisted in a pair, BELDFOIL<sup>®</sup> aluminum-polyester shield 1-.75 ohm coax, 22 AWG (6x30 and 1x29) bare copper conductor, cellular polyethylene insulation, bare copper braid shield Overall black vinyl jacket (figure-eight design) .242x.445 O.D. Standard Spool Lengths in ft. 500, 1000</p>	<p><b>9262</b></p>  <p><b>13-CONDUCTOR REMOTE CONTROL AND VIDEO CABLE</b> Recommended for use in installations requiring external drive signals, tallies, intercom, switching and video operations Underwriters' Laboratories, Inc. Listed</p> <p><b>Specifications:</b> 12-20 AWG (7x28) tinned copper conductors, vinyl insulated, color coded 1-.75 ohm coax, 22 AWG stranded bare copper conductor, foam polyethylene insulated, bare copper braid shield, polyester tape wrapped Overall tinned copper braid shield Overall gray vinyl jacket, .425" nominal O.D. Standard Spool Lengths in ft. 50, 100, 500, 1000</p> <p><b>BELDFOIL</b></p> <p><b>8451 Belden miniature audio cable, 2-conductor 22 AWG stranded, drain wire, foil shield, vinyl jacket</b></p> 
--	---



# VIDEO CHARACTER GENERATOR

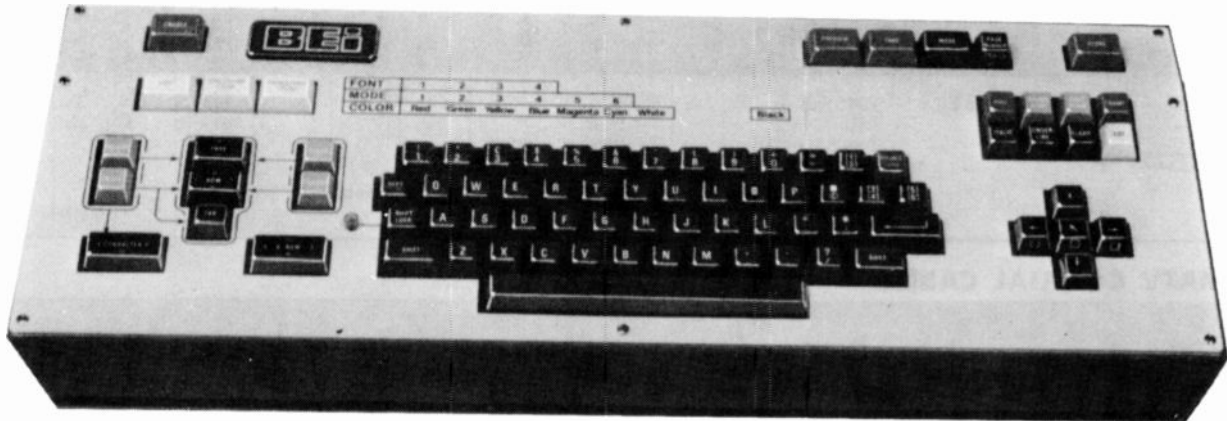

## Video Production Generator for Studio or Mobile Vans

- Multi-font display capability
- 31.25 nanosecond resolution
- Internal 150-page disc memory
- Internal character and background color generator
- No edging, full surround or drop-shadow edging
- Proportional spacing with true character overlap
- 4 speeds of roll and crawl with auto-stop
- Automatic row centering
- Italics at the stroke of a key
- 16 horizontal tab locations
- Word flash and underline
- Character insert and delete
- RS-232-C input interface
- Double logo capability up to 128 scan lines high
- Engineer's service diagnostics card
- Preview safe area and system status display
- Firmware programming
- Compact size of mainframe

## Marquee 2000 Video Character Generator — Basic System

- 2 Floppy Discs containing 25 standard fonts
- 3 double height of 6 single height logos or mix (1 double = 2 single)
- 1 150 page Floppy Disc
- 1 Service extender card
- 1 Operator's manual
- 1 Technical manual

**\$26,500.00**

### Accessories

**Additional Marquee 2000 Keyboard** — Available for English, German, Lithuanian, Russian, Greek, French, Finnish, Swedish or Norwegian languages **\$2600.00**

### Marquee 2000 Memory Recall Keyboard (Model MRKI)

A small compact keyboard providing limited control of the Marquee 2000, including: Font Load, Font Select, Cursor Shift, Row Shift, Incremental Row Shift, Select page on Disk, Take Page, Delete Page, Clear Page, Select Roll/Crawl, Select Speed of Roll/Crawl, Start-Stop of Roll/Crawl, Select Preview and Select Mode **\$1500.00**

## Marquee 2000 Dual Channel Option

This unit provides a second independent high resolution channel which, with the exception of roll and crawl, offers full function capabilities for editing and color display. Captions on disc can be first previewed and then instantly transferred to the program channel at a keystroke, with automatic read from disc of the next caption. Captions can be composed, edited, recorded and read from disc on one channel without affecting the other channel. Alternatively, captions can be recalled from disc into alternate channels on cue from the video mixer for cross-fades, wipes and other special effects.

The Dual Channel Option measures 14" x 19" x 18½" and can be supplied with or without a Disc Drive Unit.

With Disc Drive Unit **\$16,750.00**  
 Without Disc Drive Unit **\$15,250.00**  
 Marquee 2000 Disc Drive Unit **\$1500.00**

## Marquee 2000 Font Compose Unit

This unit connects directly with the Marquee 2000 Video Character Generator and provides the user with the ability to compose fonts and logos directly onto the disc. The Font Compose unit is controlled by the Marquee 2000 keyboard and measures 5¼" x 19" x 10" **\$5000.00**

Additional Standard Fonts **\$100.00 each plus disc**

### Special Fonts

Special fonts can be supplied based upon customer supplied artwork and specifications. **\$200.00 each plus disc**

**Please Note:** Once a Special Font has been supplied it is then added to our list of Standard Fonts and available to other users of the Marquee 2000.

Additional Logos (single or double height) **\$100.00 each**

Hard Sected, pre-formatted Floppy Disc **\$ 25.00 each**



# MESSAGE SYSTEM

## Marquee Model CG800

- Microprocessor and large scale integrated circuits for fewer components
- No pre-wired frame for options: options by program and board changes
- Single housing: all electronics built into the keyboard housing
- Heathkit® Digital Weather Computer for local weather instrumentation



## Data-Prompter

Automatically paces talent editing functions (word processing and story sorting) line 21 closed captioning for the hearing impaired (Live "Real Time" interface to a line 21 encoder). Easy to interface to electronic new room equipment. News stories may be skipped and re-inserted "on air". Clear easy to read display (character generated)



## Model CG-800

**Basic Message System** ..... \$2995.00

Includes: Character generator, RS-170 Color sync. generator, Microprocessor control, Keyboard and interface, 4 page memory (32 lines), Crawl line with 1000 characters, Blue matte background generator, "F" connectors (BNC, upon request).

### Rack Mounted System

For single or multiple channel systems

<b>CG-800R</b> Basic generator	<b>\$2395.00</b>
<b>800RFS</b> Rack frame for above (will hold 3 CG-800R's)	<b>100.00</b>
<b>800KRB</b> Keyboard for rack system (will operate 6 channels)	<b>500.00</b>

### Options

<b>8001KM</b> Added 32 line memory for page memory	<b>100.00</b>
<b>8001KC</b> Added 1000 characters for crawl line	<b>100.00</b>
<b>800TLG</b> RAM or PROM Title line generator	<b>100.00</b>
<b>8004CC</b> 4 Color colorizer for background	<b>200.00</b>
<b>800GLS</b> Gen-lock sync. generator	<b>300.00</b>

<b>800VPS</b> Video page switch (Programs external video into seq.)	<b>\$150.00</b>
<b>800INV</b> Inverter (for battery back-up)	<b>50.00</b>

### Interfaces

<b>800IFA</b> Interface adaptor (required for any interface)	<b>200.00</b>
<b>800RKB</b> Remote keyboard	<b>750.00</b>
<b>800FSK</b> AFSK receive board	<b>150.00</b>
<b>800HWI</b> Heathkit® weather interface	<b>250.00</b>
<b>800NOA</b> NOAA weather wire interface	<b>350.00</b>
<b>800NIF</b> NEWS wire interface (UPI or AP)	<b>350.00</b>
<b>800DTD</b> DAY-TIME-DATE interface	<b>100.00</b>

## Data-Prompter Model DP-1000

### BASIC ELECTRONICS

<b>DP-1000R</b> Rack mounted electronics with 16K* memory (order keyboard below)	<b>\$5200.00</b>
<b>DP-1000M</b> Desk top electronics with monitor, special housing and 16K* memory (order keyboard below)	<b>\$6000.00</b>

\*16K of memory is approximately 15 minutes of reading time.

### KEYBOARDS

<b>DPKB-100</b> Basic keyboard	<b>\$1600.00</b>
<b>DPKB-200</b> Basic keyboard with prompter control	<b>\$1600.00</b>
<b>DPKB-300</b> Basic keyboard with tape drive	<b>\$2950.00</b>
<b>DPKB-400</b> Basic keyboard with prompter control and tape drive	<b>\$3600.00</b>
<b>DP-PC</b> Prompter control in separate housing	<b>\$750.00</b>

### EXPANDED MEMORY

<b>DP-32K</b> Additional 32K to expand memory to 48K (maximum per terminal)	<b>\$2000.00</b>
---	------------------

### PRINTERS

Okidata Microline 82A	<b>\$800.00</b>
Data Products Corp. M-120	<b>2700.00</b>
Data Products Corp. M-200	<b>3570.00</b>
Pedestal for Data Products Printers	<b>180.00</b>

### DIGITAL TAPES

<b>DP-T80</b> 80-ft. Digital cassette tape (10 tapes per box)	<b>\$75.00/box</b>
---	--------------------



## TV/VTR CABINETS AND STANDS



MPVC40E



VTRC30E



MPVC54E



VTRC29E

### MPVC40E

Suitable for small or large group application plus a roomy storage cabinet! Recessed top shelf allows easy access to VTR Recorder/Player on middle shelf. Storage cabinet has one movable shelf and with tubular chrome legs. Shelves are inlaid with wood grained vinyl. Equipped with 2" ball carpet casters, electrical assembly and a set of 2 keys. Ships disassembled. Weight: 90 lbs. Dimensions: Outside 30"W x 40"H x 20"D, Top Shelf 30" W x 16"D, top to middle shelf 13", cabinet 28"W x 17"H x 18"D

**\$256.00**

### VTRC30E

The standard of the industry for moving, storing and utilizing video systems. Recessed top shelf. Storage cabinet has double locking doors. Constructed of heavy gauge steel, finished in Black with tubular chrome legs. Shelves are inlaid in wood grained vinyl. Equipped with 2" ball carpet casters, electrical assembly and a set of 2 keys. Ships disassembled. Weight: 64 lbs. Dimensions: Outside 30"W x 32"H x 20"D, Top Shelf 30"W x 16"D, Top to Middle Shelf 13", Cabinet 28"W x 10"H x 18"D

**\$237.00**

### MPVC54E

Accommodates a complete video system and large top is suitable for most 25" Receivers. Constructed of heavy gauge steel, finished in Black with tubular chrome legs. Shelves are inlaid with wood grained vinyl. Equipped with heavy duty 4" casters, electrical assembly and a set of 2 keys. Ships disassembled. Weight: 88 lbs. Dimensions: Outside 30"W x 54"H x 20"D, Top to Middle Shelf 26", Cabinet 28"W x 17"H x 18"D.

**\$256.00**

### VTRC29E

Similar in design to the VTR29E, features a lockable cabinet for security and protection. Constructed of heavy gauge steel, finished in Black. Double doors available in Walnut, Blue, Red or Yellow. Comes equipped with arc welded caster sockets, "Quiet-Glide" caster system, heavy duty 4" casters, smooth rounded edges, die-pressed shelves, full length piano hinge doors and a set of 2 keys. Ships fully assembled. Weight: VTRC29 66 lbs. (includes electrical unit), VTRC29 66 lbs. Dimensions: Outside 36"W x 29"H x 18"D, Cabinet 35"W x 21"H x 17"D.

**\$234.00**

### VTRC54E

Slanted top provides glare-free TV viewing. Top shelf "Double Welded" for maximum security, recessed to allow easy access to VTR. Constructed of heavy gauge steel, finished in Black. Door available in Walnut, Blue, Red or Yellow. Features arc welded caster sockets, "Quiet-Glide" caster system, heavy duty 4" casters, smooth rounded edges, die-pressed shelves, full-length piano hinge door and a set of 2 keys. Ships fully assembled. Weight: 82 lbs. Dimensions: Outside 28"W x 54"H x 24"D, Top Shelf 28"W x 17"D, Top to Middle Shelf 24". Cabinet 25"W x 17"H x 21"D

**\$256.00**

### VTR29E

Designed to accommodate a variety of both TV and AV equipment where mobility and easy access are necessary. Constructed of heavy gauge steel, finished in Slate. Comes equipped with arc welded caster sockets, "Quiet-Glide" caster system, heavy duty 4" casters, smooth rounded edges and die-pressed shelves. Ships fully assembled. Weight: VTR29E 38 lbs. (includes electrical unit), VTR29 36 lbs. Dimensions: Outside 36"W x 29"H x 18"D, Top to Bottom Shelf 20".

**\$140.00**

### C42E

Perfect for both TV and AV applications. Offers both security and mobility as well as economy. Constructed of heavy gauge steel, finished in Black, Door available in Walnut, Blue, Red or Yellow. Feature arc welded caster sockets. "Quiet-Glide" caster system, heavy duty 4" casters, smooth rounded edges, die-pressed shelves, a full-length piano hinge door and a set of 2 keys. Ships fully assembled. Weight: C42E 58 lbs. (includes electrical unit), C42 56 lbs. Dimensions: Outside 24"W x 42"H x 18"D, Top to Middle Shelf 14", Cabinet 23"W x 17"H x 17"D.

**\$183.00**



VTR54E



C42E



VTR29E



# MOBILE EQUIPMENT TABLES

## MP54 Series

Suitable for a variety of TV and AV applications. Finished in Putty Beige accented with Black legs. Features steel construction, smooth rounded edges, die-pressed shelves, "Quiet-Glide" caster system and a Square Lock Design which assembles in minutes. Slant Top Accessory (MPS models) enables glare-free TV viewing. Ship disassembled. WEIGHT: MPS54E 56 pounds (includes electrical unit), MPS54 54 pounds, MP54E 54 pounds (includes electrical unit), MP54 52 pounds. DIMENSIONS: Outside 30"W x 54"H x 20"D, Top to Middle Shelf 23", Middle to Bottom Shelf 20".

MPS54E-\$144.00 MP54E-\$138.00 MPS54-\$123.00 MP54-\$117.00

## MP30E

Large enough for a variety of AV and TV equipment, yet small enough for lightweight mobility and easy accessibility. Construction features are the same as the MP54 Series. Ships disassembled. WEIGHT: MP30E 38 pounds (includes electrical unit). MP30 36 pounds. DIMENSIONS: Outside 30"W x 30"H x 20"D, Top to Bottom Shelf 14".

MP30E-\$119.00

## MP48 Series

Offers the same quality features as the MP54 Series, with a shorter height. Suitable for large or small group application for both TV and AV presentations. Ship disassembled. WEIGHT: MPS48E 53 pounds (includes electrical unit), MPS48 51 pounds, MP48E 51 pounds (includes electrical unit), MP48 49 pounds. DIMENSIONS: Outside 30"W x 48"H x 20"D, Top to Middle Shelf 17", Middle to Bottom Shelf 20".

MPS48E-\$139.00 MP48E-\$133.00  
MPS48-\$118.00 MP48-\$112.00

## Mini Pack Series

The strength of metal combined with Bretford's Standard 5 Year Warranty make these stands the most economical on the market! Construction features are the same high quality as the MP54 Series. Ship disassembled. WEIGHT: MP42E 32 pounds (includes electrical unit), MP42 30 pounds, MP34E 30 pounds (includes electrical unit), MP34 28 pounds, MP26E 28 pounds (includes electrical unit) MP26 26 pounds. DIMENSIONS: Outside 20"W x 42, 34 or 26"H x 18"D, Top to Bottom Shelf: MP42E 21", MP34E 13", MP26E 17".

MP42E-\$74.00

MP26E-\$93.00



MP54E



MPS54E



MP48E



MPS48E



MP30E

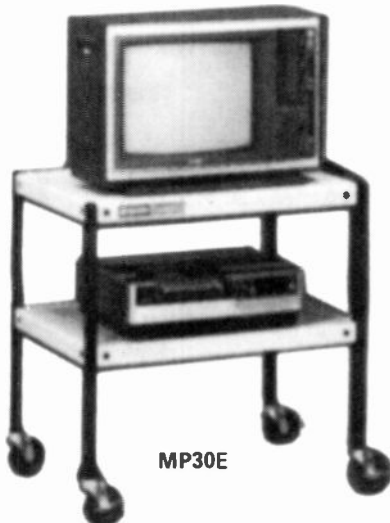

MP30E



MP34

MP42

MP26



VTRC70E

Here's beautiful furniture to provide mobility with lock-up security for your entire video system or other valuable equipment. The VTR Centers each accommodate player recorders (with a rolling pull out shelf) and a monitor in a variety of ready-to-use positions allowing small or large group use. Shelves are movable in all the centers to accept the widest variety of equipment. The strength of metal is combined with the beauty of wood. Cabinets are constructed of heavy gauge steel finished in Black and accented by wooden doors finished with a rich walnut mar-resistant laminate. Ventilated back panel on VTR models is removable, allowing access for adjustments. All cabinets roll easily on quiet, special heavy duty 4" ball bearing casters. "E" models complete with electrical assembly having 2 outlets, 20 foot 3 wire cord and grounded plug. Additional shelves are available. All units ship disassembled.

- RAS Rolling Accessory Shelf for VTRC40E, VTRC70E and VTRC80E **\$46.00**
- FAS Fixed Accessory Shelf for 40's, 70's and VTRC80E **\$20.50**
- RS Rolling Accessory Shelf for VTRC50E **\$43.80**



C70



VTRC50E-W

### VTRC70E

One rolling shelf plus two movable shelves. Dimensions: Outside 33"W x 72"H x 24"D, Inside 31"W x 60"H x 22"D. VTRC70E TV/VTR Center Wt. 268 lbs. **\$794.00**

### VTRC80E

Two rolling shelves plus two movable shelves. Dimensions: Outside 33"W x 72"H x 24"D, Inside 31"W x 60"H x 22"D. VTRC80E TV/VTR Center Wt. 281 lbs. **\$881.00**

### C70

Two movable shelves. Dimensions: Outside 33"W x 72"H x 24"D, Inside 31"W x 60"H x 22"D. C70 Security Center Wt. 253 lbs. **\$690.00**



C50-W



VTRC40E

### VTRC50E-W

Two movable shelves and one rolling shelf. Dimensions: Outside 28"W x 55"H x 23"D, Inside 26"W x 48"H x 22"D. VTRC50E-W TV/VTR Center Wt. 163 lbs. **\$541.00**

### C50-W

Three movable shelves. Dimensions: Outside 28"W x 55"H x 23"D, Inside 26"W x 48"H x 22"D. C50-W Security Center Wt. 161 lbs. **\$519.00**

### VTRC40E

One movable shelf and one rolling shelf. Dimensions: Outside 33"W x 38"H x 24"D, Inside 31"W x 30"H x 22"D. VTRC40E TV/VTR Center Wt. 144 lbs. **\$450.00**

### C40

One movable shelf. Dimensions: Outside 33"W x 38"H x 24"D, Inside 31"W x 22"D. C40 Security Center Wt. 129 lbs. **\$364.00**



C40

All prices F.O.B. Schiller Park, Illinois



**BROADCAST ELECTRONICS INC.**

## CARTRIDGE TAPE MACHINES

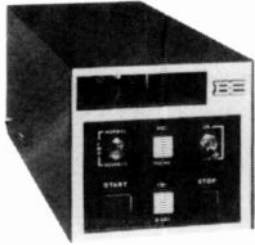

3100P



3300P



3200RP

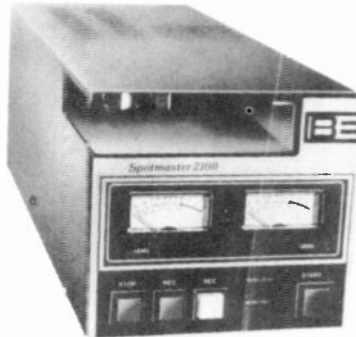

2100RPS

### Series 3000 Tape Cartridge Machines

The Series 3000 cartridge machine incorporates an automatic release deck with a large air damped solenoid. Total power consumption is so low that the Series 3000 is the coolest running unit in the industry. Modern integrated circuits are used extensively, card edge connectors have gold plated contacts and all audio sections are internally shielded. Long life heads are provided in all units. Stereo units are equipped with the new Phase-Lok IV head bracket with independent azimuth adjustment for extremely tight control of stereo phasing. The Series 3000 is available in a full range of mono and stereo models to fit all cartridge sizes. Units can be desk top or rackmounted.

Model 3100 is available in mono or stereo playback units which accept A size cartridges. Three 3100 models can be placed in a 19" rack.

Model 3200 is available as playback only or record/playback in either mono or stereo. The 3200 accepts both A and B cartridges so that two units mount in a 19" rack. Model 3300 is available in the same configurations as the 3200 but accepts A, B and C cartridges. Model 3400 comes standard in a rackmount configuration and handles A, B and C size cartridges. A 3100 player may be mounted next to the 3300 in the same rack panel. Delay models are available in mono versions of the 3200, 3300 and 3400 series.

### 605 C and 610 CR

Broadcast Electronics Five-Spot and Ten-Spot multiple cartridge units are capable of manual operation, or they may be incorporated into programmed automation systems making use of one, two or three NAB standard cue tones.

Except for the common tape drive capstan, each tape deck is an independent unit—both electrically and mechanically. Each reproduce channel has its own separate electronics including cue amplifier(s) and a program

### Series 2100 Tape Cartridge Machines

Totally new, Broadcast Electronics' 2100 family of tape cartridge machines combines versatile operation, quality components and top specifications, all at an economical price. There's more value in the 2100 series than ever found before in any professional cart machine. The combination of advanced engineering design and Broadcast Electronics' cost saving production methods produces a cart machine with double value for the most quality minded users and for those who can now afford the best.

The 2100 series has numerous benefits making it just right for nearly any application. Flexibility in size of carts accepted—A, B or C. Two cue tones (1 kHz and 150 Hz) are standard. Modular construction for easy field maintenance; Top quality Nortronics heads for exceptional performance; Direct drive transport and 1/2-inch aluminum deck for rugged, reliable operation; New Phase-Lok IV head assembly for azimuth adjustment independent of height and zenith adjustments; Exclusive Mono/Stereo switching to aid in future conversions from mono to stereo broadcasting.

amplifier. All channel output levels are separately adjustable to +4 dBm by means of locking type control. All amplifiers are plug-in modular units, and enclosed plug-in relays are used throughout. In the Ten-Spot, each module of five decks is separate from the other five-deck module.

Rear panel remote controls and inter-connections between channels are provided to permit automatic sequencing from channel to channel.



5500

### Series 5000 Multi-Deck Tape Cartridge Machines

5500

A 5-decker with rugged machined deck, dependable direct-drive hysteresis synchronous motor, air-damped solenoid and the latest electronics. An optional sequencer is available.

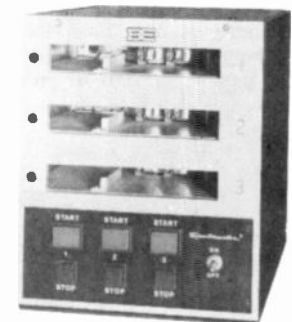

5300B

5300B

The most up-to-date monaural or stereo three deck cart machine available. Rugged machined deck, quiet air-damped solenoid, unique cartridge guidance system, drop down front panel, modular electronics, and long life heads. Companion recording amplifier available.

### Series 500 Tape Cartridge Machines

Broadcast Electronics 500D cart machines are traditional favorites that meet or exceed NAB specifications. These units have automatic cueing, automatic record cancel, built-in mike pre-amp and full auxiliary cue tone options. A wide range of desk top and rackmount units are available including mono playback, mono record/playback and mono combined record/playback/delay. The record/playback/delay unit records, stores and plays back any program material for predetermined length on standard cartridges, as well as normal record/playback functions.



**BROADCAST ELECTRONICS INC.**

## AUDIO CONSOLES

5M150

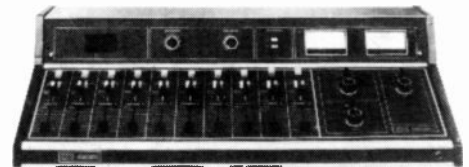
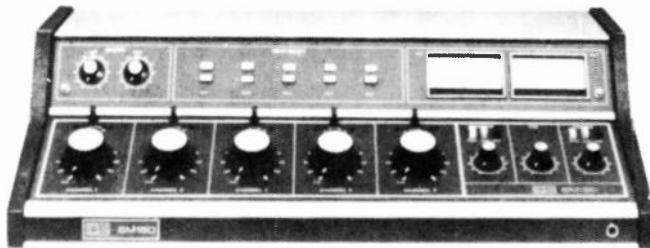

**10-Mixer, Vertical Fader,  
Dual Channel Models 10S350  
Stereo, 10M350 Mono**

22 inputs to 10 slide faders. Modular plug-in electronics. Dual channel output. Mono or stereo models. Contact-free, FET bus selection. Economical price. Durable front panel graphics.

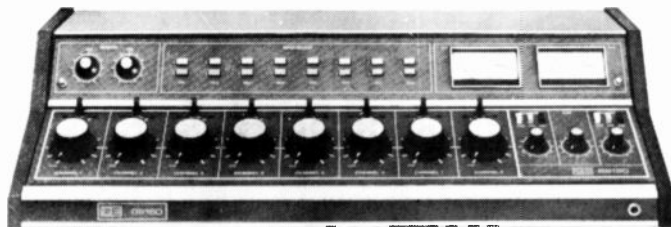

8S150

**150 Series 5- and 8-Rotary Mixer  
Mono/Stereo Consoles**

Mixing controls are of sealed potentiometer, high-reliability, long-life design, each equipped with cue bus switches. The 150 Series features contact-free FET bus selection and field-proven 3600 series plug-in modular electronics. Each mixing channel accommodates two pushbutton-selected inputs, and may be preset for either microphone or high-level service. Mono/stereo

mode switching optional on stereo models. Monitor, headphone and cue amplifiers insure full-monitoring capability. Professional performance at a reasonable price insures the broadcaster of a console tailored to his needs. Front panel graphics are under a laminated polycarbonate overlay for maximum durability.

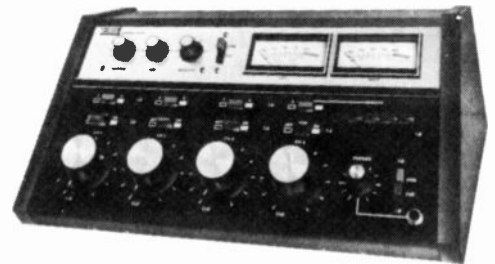

**4S50, 4-Mixer Stereo**

Stereo version of the 4M-50. Fully metered outputs. Simple, straightforward installation. Efficient, professional performance. Cue Switches, all mixers.

5M250

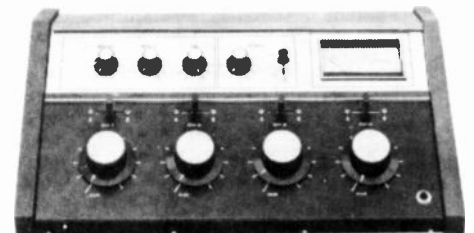

**4M50, 4-Mixer Mono**

Selectable high/low input sensitivity, all channels. Individual monitor, headphone and cue amplifiers. High reliability sealed potentiometer-type mixer controls. Two inputs per mixer.

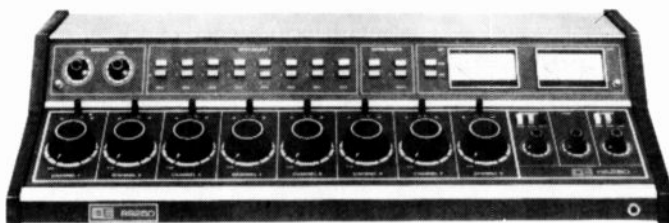

8S250

**Deluxe 250 Series 5-, 8- and 10- Rotary Mixer  
Mono/Stereo Consoles**

Featuring ladder-type maintainable step attenuators with cue bus switching, telephone-type channel keys and contact-free FET bus selection. Separate monitor, headphone and cue channels. Field proven 3600 Series modular plug-in electronics. Two-input push-

button preselection and microphone or high level capability for each mixing channel. Mono/stereo mode switching optional on stereo models. Front panel graphics are under a laminated polycarbonate overlay for maximum durability.



**4V50, 4-Mixer Mono**

10 inputs to 4 mixers. Cue switches, all mixers. For broadcast, A/V, CCTV and CCTV applications. Switchable microphone/high level inputs. Integral tone generator. 1.0 watt rms headphone and cue amplifiers.



### 3-Meter Earth Station Model 6001

The 3-Meter Earth Station Antenna offers excellent performance and maximum cost effectiveness for audio digital and video receive-only applications.

Manufactured with precision die-stamping techniques, the 3-meter antenna has six reflector panels. No special tools, panel alignment or testing are required to achieve the specified performance. Compact components allow economical transportation and facilitate assembly in remote sites or on rooftops where handling equipment is not readily available.

The single-axis mount provides pointing accuracy, structural safety, and simple pointing adjustment. With proper alignment on installation, the antenna can be pointed with a single-axis adjustment to any two satellites in the 90-136° arc with zero pointing error. Similar pointing adjustments can be made in the 70-90° arc by a single strut change.

For minimum installed cost, a specially designed foundation kit, which reduces both concrete requirements and installation time, is available.

#### Features

- Minimum shipping costs • Minimum site preparation and installation costs • No panel alignment or testing required at installation
- Single-axis mount for ease of pointing
- Rigid mechanical design • Single or dual-polarized feed system • Modular, interchangeable parts for ease of field support
- Stamped aluminum panels for consistently good surface accuracy **\$3495.00**

### 3.65 Meter Earth Station Model 6002

- Reflector Type: Parabolic, 6 panel 3.0 meter expanded to 3.65 meter diameter utilizing 12 precision die stamped aluminum panels • Reflector Diameter: 3.65 Meter
- Mount Configuration: Single-axis • Arc Coverage: 91°-136° West Longitude from within contiguous U.S. without foundation change • Foundation: Drilled pier type or suitable roof mount **\$4895.00**

### 4.6-Meter Earth Station Model 6003

The Model 6003 Earth Station Antenna substantially reduces satellite terminal costs by offering comparable performance to larger antennas. Measuring 4.6 meters in diameter it accomplishes this by utilizing a high efficiency Cassegrain design rather than a prime focus feed configuration. At the same time, the unit provides better equipment accessibility.

The 12-panel main reflector is paraboloidal and uses a shaped subreflector to focus the incoming signal to a receive-only feed horn. The design provides high gain while meeting FCC sidelobe requirements.

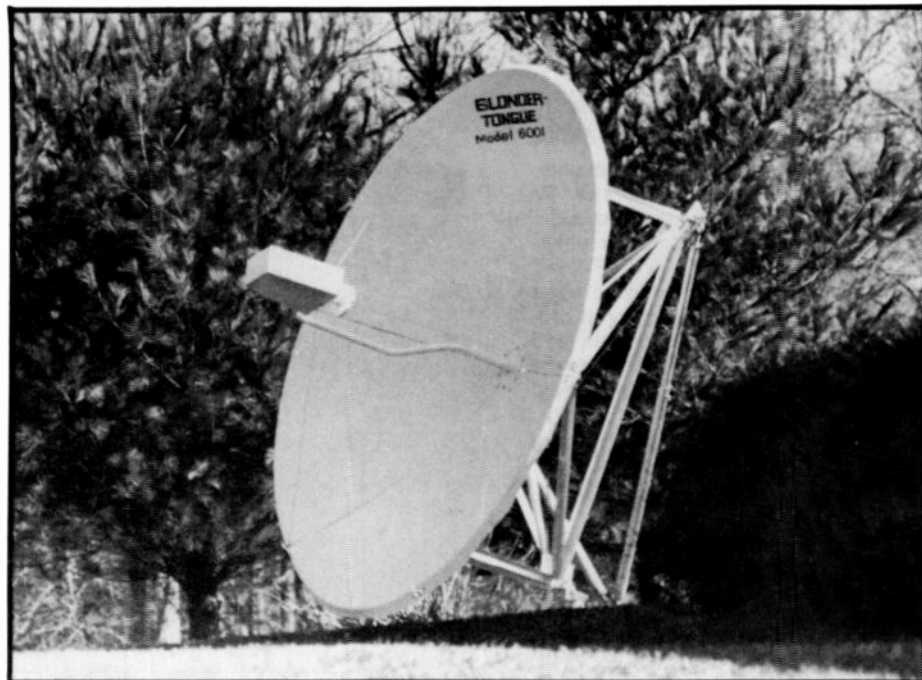

The antenna has the advantage of a modified polar mount. You simply adjust a single mount member for coverage of the orbital arc segments. Standard operation is in the 3.7-4.2 GHz frequency range for reception of satellite transmissions. Transmit capability is also available.

#### Features

- Easy assembly and positioning • No on-site alignment of reflector panels • Field proven technology • Minimum maintenance
- Interchangeable component parts • Easy access to LNA • Easy feed polarization alignment from rear of reflector • Minimum shipping volume and weight **\$5450.00**

## ACCESSORIES

### Model 6009 — Foundation Pier Kit

Permits quick hassle-free installation of the Blonder-Tongue Model 6001 or Model 6002 Antenna System. Kit consists of 3 pier foundations and three joining shear beams. All necessary hardware and full instructions are also included.

When assembled and anchored in three concrete-filled holes, the pier kit provides a rugged triangular base for easy mounting of the antenna system. **\$350.00**

### Model 6010 — 4.6 Meter Antenna Pier Kit

For quick, easy mounting of the Blonder-Tongue Model 4.6 Meter Antenna System. Construction is similar to but larger than the Model 6009. **\$525.00**

### Model 6013 — Antenna Trailer

A two-wheel computer designed trailer for easy transportation of a Blonder-Tongue Model 6001 3.0 Meter Antenna. This trailer has an integrally mounted leveling system which provides quick stabilization on rough terrain, and can be easily towed with a standard trailer hitch.

The trailer and 3.0 Meter Antenna System equips an MATV installer with a fully transportable Earth Station demo system for selling potential customers. **\$4125.00**

### Model 6015 — Receiver Mounting Tray

A self-contained mounting system that permits easy side-by-side mounting of two Model 6008 Earth Station Receivers in a standard 19" rack assembly. A blank filler plate is included for use in one-receiver installations. **\$87.00**

### Model 6016 PD-2 — Two-way Splitter

### Model 6017 PD-4 — Four-way Splitter

Multiple Receiver installations **Price on request**

### Model 3435 MS-2U/V — Two-way Splitter

Adding satellite service to existing MATV system **\$16.32**

### Model 4674 FBT Blocked Terminator

Terminating unused ports in splitters **\$32.66**

### 4928 ESM — Earth Station Modulator

Supplying an unused MATV Channel with satellite service **\$1703.61**

# BLONDER-TONGUE

# VIDEO/AUDIO MODULATOR PRODUCTS

## TVM 4930 Television Modulator

Stock No. 4930 ..... \$1743.98

The TVM is an all solid-state, high quality, audio video modulator that generates TV channel RF carriers using video and audio sources. The unit accepts standard polarity video (sync negative) of .5-2VP-P level. The TVM features a loop-thru video input and a balanced line level bridging input provided for the audio. Level controls and modulation indicators are provided on the front panel. Aural intercarrier phased locked to 4.5 MHz xtal.

- Switch Selectable VID/4.5 MHz Optional Input
- Wide Frequency Range; Ch 2 thru 13, Sub and Midband
- Balanced Low Impedance MIC Input with XLR Connector
- Vestigial Sideband Filtering Suitable for Adjacent Channel Color Systems

Various options are available in the TVM. These include:

**Option 2** ..... \$412.84  
**CHANNEL LOCK MODULE:** Visual carrier channel lock to an amplified and filtered off-the-air channel to eliminate co-channel beat.

**Option 3** ..... \$258.03  
**FCC GROUP DELAY PRE-CORRECTION NETWORK:** Envelope delay and chroma delay meet FCC Group Delay specifications.

**Option 4** ..... \$167.72  
**VIDEO LPF:** Video low pass filter removes spurious signals above 4.2 MHz from video sources to protect adjacent channels from interference.

**Option 5** ..... \$258.03  
**A/V AGC:** Audio/Video AGC controls the audio and video level to prevent overmodulation or undermodulation of aural and visual carrier respectively.

**Option 6** ..... \$129.02  
**Video AGC:** For models (Opt. 7) with composite video/4.5 MHz aural subcarrier input. Again it prevents overmodulation of the visual carrier.

**Option 7 No charge when ordered with 4930 AURAL/VIDEO SEPARATOR:** Takes composite video/4.5 MHz from a microwave receiver output and provides 4.5 MHz aural input to aural mixer and video to video modulator. Microphone input circuitry and 4.5 MHz phase lock circuits are deleted. High-level audio input is included for bench testing when 4.5 MHz aural is not available.

**NOTE:** A maximum of two options may be selected from Options 3, 4, 5, and 7. Audio AGC portion of Option 5 is not functional with Option 7. Use Option 6 with Option 7.

**Frequency Range, Standard:** TV Channel 2 to Channel 13; **Special:** Sub-band, IF, and Midband channels.

**Visual Carrier Output:** +57 dBmV.

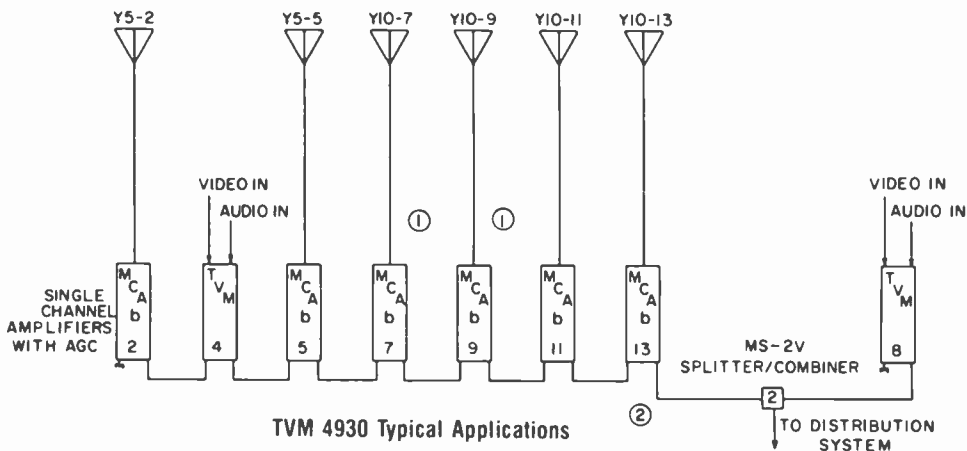
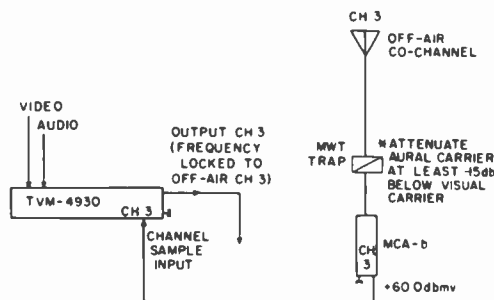
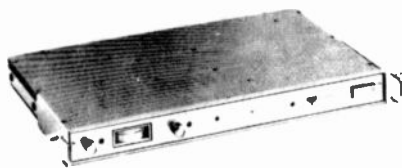

TVM 4930 Typical Applications



## AVMTa Modulator

Stock No. 4923 ..... \$1142.80

The AVMTa is an all solid-state, audio video modulator that provides a modulated visual and modulated aural carrier RF output on any single VHF TV channel 2-13. It can be used to put sound and color video on any unused channel of a closed circuit, MATV or CATV system. The AVMTa works with standard video sources such as a TV camera, video tape recorder, or TV demodulator. The wide range audio input can be directly driven from an AM or FM tuner tape recorder, or Hi Impedance dynamic or crystal microphone. The AVMTa may also be used for carrier substitution.

The model number of the AVMTa indicates its channel of operation, e.g., AVMTa-4 is a channel 4 unit. All AVMTa's are designed for rack or cabinet mounting.

**Frequency Range, Standard:** SUB Channels B-1 to B-6; VHF Channels 2 to 13; **Special Order:** Midband.

**Spurious Beats in adj. channel at +50 dBmV output:** -50 dB min., -65 dB typ.; **All other spurious outputs up to 300 MHz:** -60 dB, -65 dB typ.

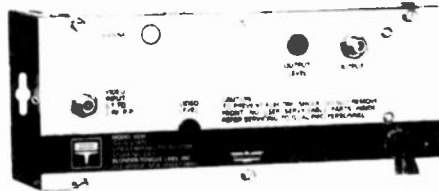

## VCM: Video Channel Modulator

Stock No. 4926 ..... \$308.33

The VCM-4926 solid-state video channel modulator is designed to provide low cost modulated visual carrier RF output on any single TV channel 2-13. It may be used as a carrier substitution generator.

The VCM contains a vestigial sideband filter, suitable for adjacent channels operation and also assures quality performance for both monochrome and color TV channels. The operating RF output level is at least +20 dBmV with a control provided on the front panel for adjustment over a 14 dB range. The VCM accepts video inputs from a line, film chain, camera or TV demodulator. The video signal before modulation is DC restored at tips of sync, thus preventing variations in the RF output due to changes in the picture content.

\*Specify Channel

# BLONDER-TONGUE

# DISTRIBUTION EQUIPMENT



### CATV INDOOR DISTRIBUTION AMPLIFIERS

#### DA-51 2/3 WIDEBAND DISTRIBUTION AMPLIFIERS

- Specifically Designed for CATV "DROP" Distribution Systems
- Wide Frequency Range for Incorporating MID-SUPER Bands with VHF/FM

Designed for TV signal distribution systems that use a CATV "drop" as a signal source. 50 to 300 MHz bandpass. An excellent amplifier for apartment buildings fed from a CATV system wide frequency range allows the DA-51 to be used in systems incorporating MID and SUPER band channels with the standard VHF and FM channels. Push-Pull Hybrid IC output. Has high output capability of 56 dBmV on each of 12 channels. Two models of the DA-51 are available: DA-51-3 with a slope control covering 50-300 MHz, and DA-51-2 with a slope control operating between 50-220 MHz.



#### DA-21 CATV DISTRIBUTION AMPLIFIER

- Ideal CATV Distribution Amplifier in Small Apartment Buildings

The latest in CATV distribution amplifiers. 50-300 MHz response. Includes many features found only in higher priced units.

#### DA-30 WIDEBAND DISTRIBUTION AMPLIFIER

- Flat Response — 50-300 MHz.
- 40 dBmV Output per Channel for 21 Channels.
- Front Panel Gain and Slope Controls.
- Slim Line Design — Easy to Install.

Designed specifically for apartment building and other multi-set installations served by CATV. Features flat response from 50 to 300 MHz for distribution of VHF, MID, and SUPER band channels. Good output capability and wide gain and slope control ranges make it easy to adapt to any system. Front panel gain and slope controls.

#### DA-33 WIDEBAND AMPLIFIER

- Ultra-Wide Bandwidth 0.5 MHz-300 MHz
- Push-Pull Hybrid IC Amplifier
- Exceptionally High Output

The DA-33 features extremely wide bandwidths; 0.5 MHz to 300 MHz, wide range continuous gain control and surge protected amplifier and power supply sections. It is ideal for increasing the output level of sweep generator or signal generator to test very lossy devices under test, such as long lengths of coaxial cables, coaxial relay isolation, etc. The DA-33 is also used as a preamplifier for CATV signal level meter (SLM) used to make FCC required signal leakage measurements. It may also be employed as a sub-channel return amplifier. In this case external multiplexers such as Blonder-Tongue MSVM are required to bypass VHF in the forward direction.

The DA-33 is also used aboard ship where its coverage of the short wave and communications bands is desired.

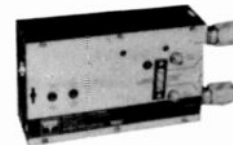
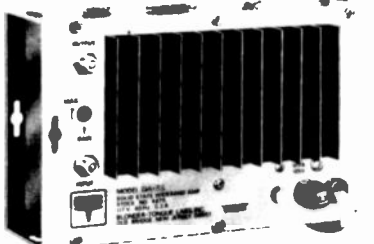

#### LP-30 CATV LINE EXTENDER AMPLIFIER

- 50-300 MHz — 30 Channel Capability

The LP-30 is designed for direct insertion in CATV branchlines. It may be powered from either the input or output side of the thru-line and has a 6-amp thru power capability. Up to five amplifiers may be cascaded for maximum branchline extension.

Input and output test jacks are backmatched and provide a means of testing the unit's performance without interrupting service. A power-selector board allows installers to select input, output, or through powering, and a wide range gain control allows gain to be varied over a 19 dB range. The unit's slope control will supply any degree of cable slope between 6 and 20 dB.

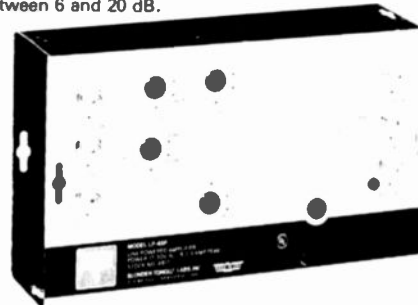

#### LP-45P IN-LINE AC POWERED AMPLIFIER

- High Output and Gain Provide Exceptional Stability
- Added Flexibility — Wide Range Gain and Tilt Controls

The LP-45P amplifier is designed for VHF/FM CATV distribution systems in which AC power is duplexed on the TV signal distribution cable. The unit accepts power from either its input or output sides. It will pass power straight through or can be used to block power from either side. Connectors are standard 75-ohm, F-type. Test points (isolated from AC power) are provided on both the input and output. This amplifier features all solid state, printed circuit board construction. Split-band amplifier design permits separate gain and band slope adjustment (low band with FM and high band). Wide trunkline spacing and elimination of temperature equalizers is possible, owing to the wide dynamic range of the LP-45P.

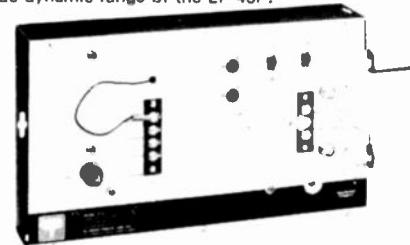

#### CATV LINE POWERED AMPLIFIERS

##### LP-51 CATV LINE EXTENDER AMPLIFIER

- High Output Capability
- 50 to 300 MHz Bandpass
- Wide Range Gain and Slope Control
- Push-Pull Hybrid IC Output

The LP-51 is a pedestal-mounted CATV line amplifier designed for direct insertion in CATV branch lines. Input and output connectors for .412 cable are located at the same end of the unit to facilitate installations in CATV pedestals. (.500 connectors available on request). The LP-51 may be powered from either the input or output side of the thru-line. A power selector jumper board allows installers to block power from either the input or output connector or to pass power thru the amplifier. The voltage necessary to power the amplifier ranges from 20 to 60 VAC.

Model	* Stock No.	Slope Control		Connectors	
		220 MHz	300 MHz	500 AL	.412 AL
LP-51-24	4421-24	X			X
LP-51-34	4421-34		X		X
LP-51-25	4421-25	X		X	
LP-51-35	4421-35		X	X	

Prices and Specifications Subject to Change Without Notice.

# BLONDER-TONGUE

## VARI-FLEX MODULAR HEADENDS

### Modular Design Eliminates Costly Wiring

The perfect headend for medium to large MATV systems. Easily balances alternate channel signal levels, and amplifies TV and FM signals from broadband and/or single channel antennas. System consists of: an input separator (when broadband antenna is employed); up to 8 adjustable-level, single-channel input filters; dual-band VHF amplifier with regulated power supply, and mounting base; lockable cover; and mounting provisions for four, 4-way signal splitters. Provisions exist for single channel UHF converter modules in place of VHF input filters.

Bandpass filters isolate weak from strong signals and T-type level controls reduce signals which may be 10 times stronger than weak ones. High output capability is designed for driving up to 150 outlets, and excellent amplifier backmatch reduces reflections from the distribution system by 80%. Line voltage variations between 100-129 VAC are smoothed by a regulated DC power supply. True labor-saving plug-in design minimizes poor reliability of conventional, interconnecting cables.

The Variflex amplifier is intended for a non-adjacent channel distribution system.



### VARI-LFEX AMPLIFIER

- **Output Capability** : LB/FM= +56 dBmV (0.63v);  
HB= +53 dBmV (0.45v)
- **Gain Adjustable from . . .** : LB/FM=31 dB to 51 dB;  
HB=25 dB to 45 dB
- **Match (Avg. Return Loss)** : Input=14 dB RL  
Output=14 dB RL
- **Noise Figure (Avg. at Max. Gain)** : LB/FM=9 dB;  
HB=8 dB
- **Min. Input for TASO Grade 1 Picture (Excell.)** : LB/FM= -4 dBmV (600 $\mu$ v)  
HB= -5 dBmV (560 $\mu$ v)
- **Noise Figure Increase per dB Gain Reduction** : LB/FM= 0.4 dB  
HB= 0.6 dB
- **Bandpass Flatness** :  $\pm$ 0.5 dB
- **Power Supply** : Regulated, compensates for line fluctuations from 100 VAC to 129 VAC



\*Specify Channel

### VARI-FLEX FILTER

- **Selectivity** : 40 dB down 9 MHz from channel center  
TV Channels 2-13 FM
- **Return Loss** : 20 dB down 6 MHz from band edge
- **Attenuation Range** : 13 dB RL (input)
- **Bandpass** : 6 dB (min. loss) to 24 dB
- **TV Channels 2-13** : 6 MHz ( $\pm$ 0.75 dB Flatness)
- **FMA** : 88-108 MHz
- **FMB** : 92-108 MHz

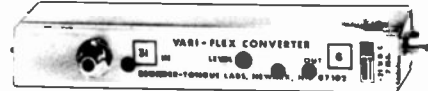

\*Specify Channel

### VARI-FLEX CONVERTER

- **All UHF to VHF Conversions except** : Channels:  
22-25 to 7  
25-28 to 8  
28-31 to 9  
31-34 to 10  
34-37 to 11  
37-40 to 12  
40-43 to 13
- **Gain/Attenuation** : Adjustable from +3 dB to -22 dB
- **Return Loss** : Input= 12 dB RL  
Output= 8 dB RL
- **Selectivity** : 10 dB down 6 MHz from band edge
- **Power Requirement** : -21 VDC (supplied from amplifier)



### VARI-FLEX SEPARATOR

- **Impedance** : 75 ohms
- **Return Loss** : 18 dB RL (input)
- **Insertion Loss** : 0.3 dB
- **Isolation between outputs** : 20 dB min.



### VARI-FLEX SYSTEM COVER

- **Dimensions** : 17 $\frac{1}{2}$ "L x 10"W x 6 $\frac{1}{4}$ "H
- **Material** : 20 Gauge Turnplate (coated steel)
- **Finish** : Black Textured
- **Weight** : 5 $\frac{1}{4}$  lbs.
- **Accessories** : Double bit tumbler lock and two keys



### VARI-FLEX FILLER MOUNT

Used to mount 4576 Filters if they are not used as a part of a VARIFLEX System.

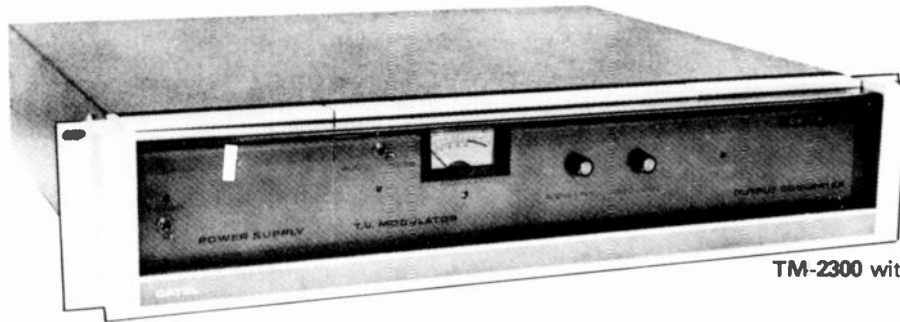

TM-2300 with tamper-guard cover

### TM-2300 Television Modulator

The TM-2300 Television Modulator incorporates the latest design concepts and components. To insure broadcast quality and to meet the most demanding CATV and CCTV system requirements, IF modulation is used. The design approach provides the convenience of rapid channel change through the use of a modular channel converter.

The TM-2300A is designed for use with film chains, cameras, video tape recorders or television demodulators. For microwave applications the TM-2300B is available with composite video and 4.5 MHz intercarrier input.

High VHF, low VHF, sub-low VHF and mid-band frequencies are available. Special models have been designed for use with PAL (German) and SECAM (French) color systems.

#### Features

- Output level up to 60 dBmV • Step attenuator output control • Illuminated meter for sound and video modulation levels • IF modulation . . . channel change simplified • Low differential gain,  $\pm 0.5$  dB • Low differential phase,  $\pm 1.0^\circ$  • High impedance and 600 Ohm audio input • Tamper guard front panel, protects pre-set adjustments • Frequency range 6-270 MHz • Ten pole band pass filter • Integrated circuits

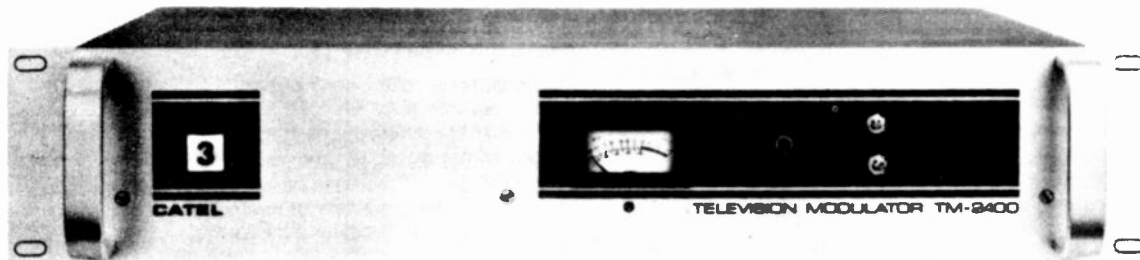

### TM-2400 Television Modulator

The TM-2400 TV modulator brings the advantages of IF modulation within reach of almost any CATV and CCTV system. Technical performance is close to that of the more expensive, fully modular CATEL TM-2300, and the instrument meets the most stringent broadcast, CATV and CCTV requirements. It can be used with film chains, cameras, VTR's or TV demodulators. For microwave, a second version (TM-2400B) is available with composite video and 4.5 MHz intercarrier input. A model is also available for PAL standards at a slightly higher price.

In addition, the TM-2400 is the only unit in its price range with easy, in-the-field channel change, a feature usually found only on more expensive modulators, like the TM-2300.

As a result, users can change the operating channel by simply changing a P.C. board assembly. Aural and visual circuits are also modular, to make field maintenance easier. Since the IF design allows modulation at a fixed frequency, filters are optimized for a true vestigial side band signal.

#### Features

- IF modulation at moderate price • In-the-field channel change • Output level of +54 dBmV optional • Meter for both video and sound modulation levels • Low differential gain:  $\pm 0.5$  dB • Low differential phase:  $\pm 1.0^\circ$  • Automatic white limiter • High impedance or 600 Ohm audio input • 6 to 270 MHz frequency range • Ten pole band pass filter

#### TELEVISION EQUIPMENT

TM-2400 A or B	Television Modulator (IF Modulation) (CCIR-M, U.S.A.) For Any VHF Standard, or Sub, Mid, Super-High Channels	\$ 895.00
TM-2400AE	Television Modulator (For CCIR-B/European Systems) (220 V.A.C.)	1,095.00
TC-2400	Channel Converter PC Assembly	215.00
	PURCHASED SEPARATELY	
	EXCHANGE	150.00
TM-2300 A or B	Television Modulator (IF Modulator-Modular Design) (CCIR-M U.S.A.) For Any VHF Standard, or Sub, Mid, Super-High Channels	1,295.00
TM-2300AE	Television Modulator (For CCIR-B/European Systems) (220 V.A.C.)	1,495.00
TC-2300	Channel Module for TM-2300	275.00
	PURCHASED SEPARATELY	
	EXCHANGE	195.00
TM-2300 IF	I.F. Module (When Purchased Separately)	780.00
TM-2300 IF (E)	I.F. Module (CCIR-B European)	975.00
PS-2300A	Power Supply (When Purchased Separately) (220 V.A.C. Optional)	195.00
CA-2300	Cabinet (When Purchased Separately)	175.00
GDF-2300	FCC Group Delay Pre-Distortion Network (U.S.A.)	175.00
GDF-2300 (E)	CCIR 'B' Group Delay Pre-Distortion Network (Europe)	250.00
VCS-2000	Video Controlled Switcher (Module)	350.00
VCS-2000-S	Video Controlled Switcher, Complete With Power Supply, Cabinet, Spacer	675.00

Prices and Specifications Subject to Change Without Notice.

## WIRELESS MICROPHONE SYSTEMS\*

### The Professional I

- Crystal controlled, VHF operation for low interference.
- Pocket - sized transmitter with 50mW power output and distortion free overmodulation protection.
- Transmitter circuitry sealed in separate compartment from battery, all within a noiseless, unhinged, impact-resistant cyclac case.
- Ultra-sensitive, high performance receiver with 4-cavity helical-resonator preselector for optimum selectivity and low interference.
- Excellent audio response, 40Hz — 15kHz.
- Multi-function metering on transmitter and receiver.
- 150 to 216MHz operating frequency range includes NEW wireless microphone channels.



Professional I Model 77 Transmitter and Model 58 Receiver **\$1904.00**  
Professional I/D Model 77/D Transmitter and Model 58/D Receiver **\$2282.00**

### The Professional II

- Crystal controlled, VHF operation for low interference.
- Pocket - sized transmitter with 50mW power output and distortion free overmodulation protection.
- Transmitter circuitry sealed in a separate compartment from battery, all within a noiseless, unhinged, impact-resistant cyclac case.
- Ultra-sensitive, high performance dual-diversity receiver virtually eliminates fades and dropouts for greater reliability and longer effective range.
- Excellent audio response, 40Hz — 15kHz.
- Multi-function metering on transmitter and receiver.
- 150 to 216 MHz operating frequency range includes NEW wireless microphone channels.



Professional II Model 77 Transmitter and Model 63 Receiver **\$3036.00**  
Professional II/D Model 77/D Transmitter and Model 63/D Receiver **\$3463.00**

### The Performer I

- Crystal controlled, VHF operation for low interference.
- One piece microphone-transmitter with no cables and integral antenna.
- Transmitter is battery powered, throw-away or rechargeable type.
- Ultra-sensitive, high performance receiver with 4-cavity helical-resonator preselector for optimum selectivity and low interference.
- Excellent audio quality, 50Hz — 15kHz response with low harmonic distortion and better than 70dB signal-to-noise overall.



Performer I Model 80 or 81 Transmitter and Model 58 Receiver **\$2090.00**

Performer I/D Model 80/D or 81/D Transmitter and Model 58/D Receiver **\$2340.00**

### The Performer II

- Crystal controlled, VHF operation for low interference.
- One piece microphone-transmitter with no cables and integral antenna.
- Transmitter is battery powered, throw-away or rechargeable type.
- Ultra-sensitive, high performance receiver with 4-cavity helical-resonator preselector for optimum selectivity and low interference.
- Excellent audio quality, 50Hz — 15kHz response with low harmonic distortion and better than 70dB signal-to-noise overall.
- Diversity receiver is extremely sensitive, selective and reliable; prevents fades and dropouts in extreme environments, on crowded stages and sets, or at longer operating distances.



Performer II Model 80 or 81 Transmitter and Model 63 Receiver **\$3222.00**  
Performer II/D Model 80/D or 81/D Transmitter and Model 63/D Receiver **\$3521.00**

### The Traveler I

- Lightweight, compact and battery powered receiver can be powered by external sources for truly portable operation.
- Receiver is extremely sensitive, selective, and reliable; all controls, connectors and monitoring on front panel for added convenience
- Crystal controlled, VHF operation for low interference.



- Pocket-sized transmitter with 50mW power output and clip-free over-modulation protection.
- Transmitter circuitry sealed in separate compartment from battery, all within impact-resistant, unhinged, noiseless cyclac case.
- Excellent audio response, 40Hz — 15kHz.
- Multi-function metering on transmitter and receiver.

Traveler I Model 77 Transmitter and Model 66 Receiver **\$1778.00**  
Traveler I/D Model 77/D Transmitter and Model 66/D Receiver **\$2134.00**

"D" in model number indicates Dynex low-noise compandored system.

\*Systems include all cables, batteries, & choice of microphones for 77B (see mic section)

#### ORDERING INFORMATION FOR CETAC VEGA WIRELESS MICROPHONE SYSTEM

Frequencies must be specified when transmitters or receivers are ordered. Review list of accessories to see if some of them will assist in your application.

# CHRISTIE

## REFLEX®-20 SELECTION GUIDE



# BATTERY PACKS — CHARGERS



### ReFLEX-20 Battery Pack Features

- Special ni-cad cells
- Resealable vents
- 3-way matching
- Each pack includes thermistors, thermal switches, and thermal fuses
- Welded connections
- 1000 to 5000 cycle average life

### ReFLEX-20 Charger Features

- Full recharge in 12 to 20 minutes
- Even faster recharge of partially discharged batteries
- Longer battery cycle life
- Less capacity fading
- Patented charge termination circuit
- Charger termination backup
- Hot battery charge lockout
- State-of-charge indicator

CHARGERS			Charger to Battery Cable	RECORDERS		CAMFRAS										LIGHTS								
115 Volt 60 Hz	230 Volt 50/60 Hz	115/230 Volt 50/60 Hz		JVC CR-4400U	RCA HR10-20	Sony BVU-100	Sony VL-3000	Akai VTS-150	Ampex BCC-4	Ampex BCC-14	Ikegam HL-33	Ikegam HL-35	Ikegam HL-77	NI C-MNC-71CP	Philips LDK 14	RCA TK-76	Sony DXC-1600	Thomson-CSF MicroCam	ColorCam	30VDC Light	Sylvania 30V Sun Gun			
S12A0	S12A0Z2	S12A0Z12		•	•	•	•																	
S12A1	S12A1Z2	S12A1Z12	-					•																
S12A2	S12A2Z2	S12A2Z12	-						•															
D6A06	D6A06Z2	D6A06Z12	-											•	•									
D6A08	D6A08Z2	D6A08Z12	-						•															
D12A0	D12A0Z2	D12A0Z12	-	•	•	•	•																	
D12A1	D12A1Z2	D12A1Z12	-					•																
D12A2	D12A2Z2	D12A2Z12	-																					
D12B2	D12B2Z2	D12B2Z12	-																					
SM12A	SM12AZ2		CB1	•	•	•	•																	
			CB2																					
			CB8																					
DM612B	DM612BZ2	DM612CZ12	CBB1	•	•	•	•																	
			CB4																					
			CB5																					
			CBB2																					
CBB8																								

• Charges one battery in less than 20 minutes      ♦ Charges one battery in less than 20 minutes, or two batteries in less than 40 minutes (in sequence)  
 ■ Charges one battery in less than 40 minutes

BATTERY PACKS	B TO 1 CABLE OR CONNECTOR																							
10B25A3																								
10B25C3																								
11B40Z3	B1 <sup>1</sup>	C35 <sup>1</sup>																						
		BF 4																						
12B40Z3	B1	C34 <sup>1</sup>																						
		BF 3																						
		BBI 3																						
		BI.11																						
		BBI 11																						
		BF 18																						
		BBI 18																						
12BB40A3																								
12BB40Z3 <sup>1</sup>	B1 <sup>2</sup>	BI 7																						
		C35 <sup>1</sup>																						
6BB40Z3	B1 <sup>3</sup>	BE 8																						
		BBF 8																						
		BF 16																						
		BBI 16																						
8BB40Z3 <sup>4</sup>	B1 <sup>3</sup>	C35 <sup>1</sup>																						
		BI 17																						

▲ Appropriate battery pack and cable or connector.  
 ♦ Allows two battery packs to be operated in parallel.

<sup>1</sup> Connector only.  
<sup>2</sup> Belt Pack for size 36 to 44. Substitute B2 for size 40 to 48.  
<sup>3</sup> Consists of two 12B40Z3 packs, series connected on one belt.  
<sup>4</sup> Consists of two 8B40Z3 packs, series connected on one belt.

# SEQUENCER

The Sequencer Model RS1, when used together with ReFLEX-20 Charger Model DM612B\* and appropriate cables, provides numerous benefits:

- Requires less than 4 hours to charge up to 8\*\* intermixed ReFLEX-20 batteries automatically in sequence\*\*\*
- Requires even less time for fewer batteries, without need for reconnection
- Shows state-of-charge of any battery connected by utilizing manual override
- Indicates cycle status and battery being charged
- Allows system to be left on for prolonged periods without damage to batteries
- Accepts input of 115 or 230 volt, 50/60 Hz., when used with appropriate charger
- Saves space by fitting under charger: size 10 1/4" w x 5 1/4" h x 9 3/8" d. Weight 11 1/2 lbs.

\* DM612BZ2 for 230 volt, 50/60 Hz. applications  
 \*\* Count batteries with plus and minus sections (e.g., HL-33, HL-35, HL-77) as 2 batteries  
 \*\*\* unless batteries too hot from prior discharge - see automatic charger lockout

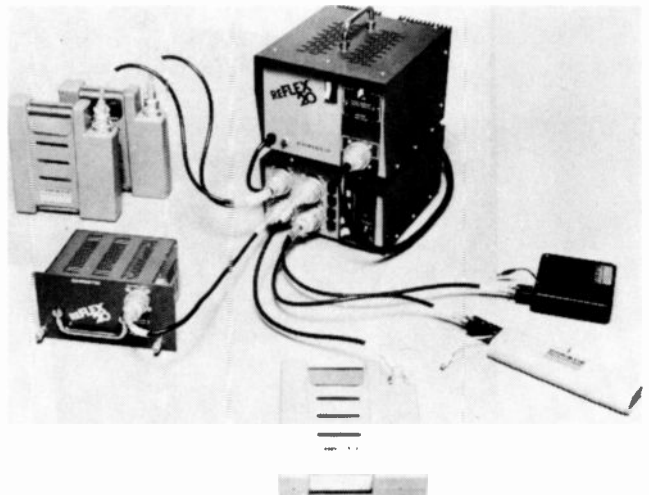

# CHRISTIE

## REFLEX®-20 SELECTION GUIDE

CAMERA OR VTR	REFLEX-20 BATTERY				REFLEX-20 CHARGERS (115V, 60 Hz)						BATTERY-TO-EQUIPMENT CABLES	
	Model	Aprx. run-time Minutes		Specify Belt	Single Channel Charge Cable		Dual Channel Charge Cable		Multi-Purpose Charge Cable		Single	Dual
		Single	Dual		Model	Charge Cable	Model	Charge Cable	Model	Charge Cable		
<b>AMPEX</b> BCC-14	HR1	100	220	YES	SF2	Included	DB2	Included	DMB	CBB8	BE18	BBE18
<b>HITACHI</b> SK-90	HR1	75	—	YES	SF2	Included	DB2	Included	DMB	CBB8	BE26	—
SK-91	KR 1	100	—	NO	SG 2	Included	DG 2	Included	DMB	CBB14	—	—
FP-40	KR 1	80	—	NO	SG 2	Included	DG 2	Included	DMB	CBB14	—	—
FP-20	HR 1	80	—	YES	SF 2	Included	DB 2	Included	DMB	CBB8	—	—
<b>IKEGAMI</b> HL-33	ER3	60	—	NO	—	Included	DA2	Included	DMB	CB4	—	—
HL-35	ER3	60	—	NO	—	Included	DA2	Included	DMB	CB4	—	—
HL-77	HR2	60	130	YES	—	Included	DA06	Included	DMB	CB5	BE8	BBE8
HL-79	KR1	100	—	NO	SG2	Included	DG2	Included	DMB	CBB14	—	—
<b>JVC</b> CR-4400	ER5	90	—	NO	SF0	Included	DA0	Included	DMB	CBB1	—	—
<b>NEC</b> MNC-71	HR2	60	—	YES	—	Included	DA06	Included	DMB	CB5	BE16	BBE16
<b>PHILIPS</b> LDK-14	HR1	100	220	YES	SF2	Included	DB2	Included	DMB	CBB8	BE18	BBE18
VIDEO-80	2 of HR3	—	100	YES	—	Included	DB0	Included	DMB	CBB12	—	BE22
<b>RCA</b> TK-76	HR1	60	130	YES	SF2	Included	DB2	Included	DMB	CBB8	BE3	BBE3
<b>SONY</b> VO-3800	ER4	90	—	NO	SF0	Included	DA0	Included	DMB	CBB1	—	—
BVU-100	ER4	90	—	NO	SF0	Included	DA0	Included	DMB	CBB1	—	—
BVU-50	ER6	225	—	NO	SE0	Included	DC0	Included	DMB	CBB11	—	—
BVH-500	2 of ER6	—	—	NO	SE0	Included	DC0	Included	DMB	CBB11	—	—
BVU-110	ER6	200	—	NO	SE0	Included	DC0	Included	DMB	CBB11	—	—
DXC-1600	ER4	90	—	NO	SF0	Included	DA0	Included	DMB	CBB1	—	—
BVP-300	KR1	120	—	NO	SG2	Included	DG2	Included	DMB	CBB14	—	—
DXC-6000	KR1	140	—	NO	SG2	Included	DG2	Included	DMB	CBB14	—	—

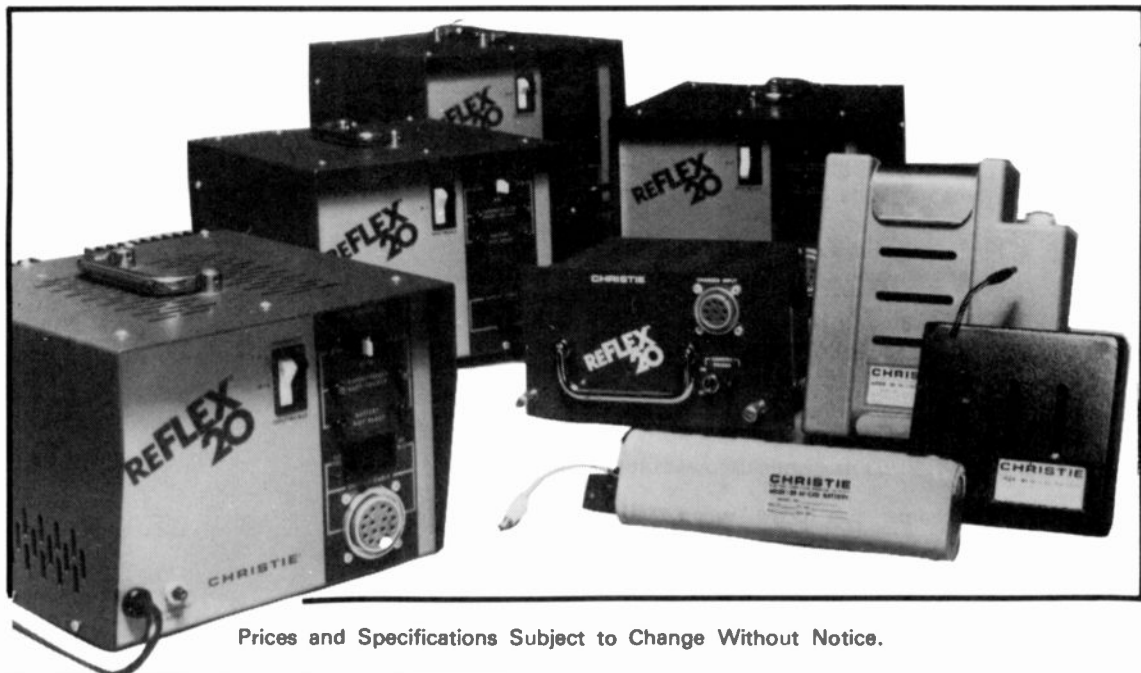



# CHRISTIE

## REFLEX®-20 SELECTION GUIDE

### CHARGERS & POWER SUPPLY

115/230V 50/60Hz	115V 50/60Hz	230V 50/60Hz	115V 60Hz	UNIT PRICE	USED ON
		DMB22	DMB	\$1,550.00	*
	DMBZ1			1,750.00	*
DMCZ				1,950.00	*
SF0Z				1,150.00	ER4, ER5
SF1Z				1,150.00	HR4
			SF2	975.00	HR1
SF2Z				1,150.00	HR1
SB0Z				1,150.00	HR3
SE0Z				1,150.00	ER6
SK1Z				1,150.00	KR1
SK2Z				1,150.00	KR2
KS1				650.00	All KA Mounts

### PRINTED CIRCUIT BOARDS

MODEL	UNIT PRICE	USED ON
PCBS	\$ 165.00	All "S" Series Chargers
PCBD	230.00	All "DM" Series Chargers

### MOUNT ADAPTERS

MODEL	UNIT PRICE	USED ON
KA12	\$ 95.00	Kit, Mount Adapter for Sony BVP-300/330, Thomson MC-601
KA20	145.00	Kit, Mount Adapter for RCA TK-76B, C
KA21	70.00	Kit, Mount Adapter for RCA TK-86
KA23	†	Kit, Mount Adapter for Ampex BCC-20
KA24	85.00	Kit, Mount Adapter for Ikegami HL-79(D)
KA25	85.00	Kit, Mount Adapter for Ikegami ITC-350
KA26	105.00	Kit, Mount Adapter for Toshiba PK60
KA27	95.00	Kit, Mount Adapter for Sharp XC-700
KA28	95.00	Kit, Mount Adapter for Hitachi SK91, SK81 & FP10

### BATTERY CONNECTORS

(Allows Customer to make "BE" Cable)

MODEL	UNIT PRICE	USED ON
C34	\$ 48.00	HR1
C35	48.00	HR2, HR3, HR4

### CABLES — CHARGER-TO-BATTERY

MODEL	UNIT PRICE	USED ON
CB5	\$ 95.00	HR2
CB9	95.00	Ampex VPR-20
CBB1	120.00	ER4, ER5
CBB2	165.00	HR4
CBB8	165.00	HR1
CBB11	165.00	ER6
CBB12	165.00	HR3
CBB14	195.00	KR1
CBB16	195.00	KR2
KB2	165.00	SF2 to KR2 Interface
KRX	75.00	Mount Adapter-Cable Interface

### CABLES — BATTERY-TO-EQUIPMENT

MODEL	UNIT PRICE	USED ON
BE3	\$ 195.00	RCA TK-76
BE7	195.00	Sun Gun/Mini-Pro/Omni
BE8	120.00	Ikegami HL-77
BE11	120.00	Thomson MC-602
BE12	85.00	Unended Cable to HR1
BE16	165.00	NEC MNC-71, Bosch KCA-90
BE18	120.00	Ampex BCC-14; Philips LDK-14
BE19	195.00	Panaflex 35mm
BE20	120.00	Arri 35 BL, 16SR, 16ST; RCA TK76, TK86, w/KRX and KA Mount
BE21	165.00	Arri 16 BL
BE22	195.00	Philips Video-80
BE26	120.00	Hitachi SK-90, FP1020, GF7
BE27	85.00	Unended Cable to HR3
BE28	165.00	Hitachi SK-80
BE30	105.00	RCA TK-86 w/KA21 and KRX to 4-Pin XLR Connector
BBE3	275.00	Dual RCA TK-76
BBE8	220.00	Dual Ikegami HL-77
BBE11	195.00	Dual Thomson MC-602
BBE16	255.00	Dual NEC MNC-71
BBE18	220.00	Dual Ampex BCC-14; Philips LDK-14
BBE20	220.00	Dual Arri 35 BL, 16SR, 16ST

### BELTS

MODEL	UNIT PRICE	USED ON
B0	\$ 30.00	Small 31-39
B1	30.00	Medium 35-43
B2	30.00	Large 39-47
B3	30.00	X-Large 43-51

### SEQUENCER

MODEL	UNIT PRICE	USED ON
RS1A	\$1,470.00	DMB, DMBZ1 & DMBZ2; requires 4 "CB(B)" cables for full operation

### BATTERY PACKS

MODEL	UNIT PRICE	USED ON
ER4	\$ 350.00	Sony BVU-100, VO-3800
ER5	320.00	JVC CR-4400U; RCA HR1020; Panasonic 9400
ER6	370.00	Sony BVU-50, BVH500** , BVU110; RCA TH-50**
HR1	450.00	Ampex BCC-14; Hitachi FP1020, SK-90; Philips LDK-14; RCA TK-76A, 3, C; Thomson MC-602; Arri 16SR, 16ST, 16B-, 35BL; Panaflex 35mm**; 30V, 250 watt lights**; Hitachi GF7
HR2	485.00	Ikegami HL-77; NEC MNC-71; Bosch KCA-90
HR3	415.00	Philips Video-80**
HR4	435.00	Hitachi SK-80**
KR1	435.00	Hitachi FP-40; Sony BVP300/330; Thomson MC-601
KR2	450.00	Ampex BCC-20†; Ikegami HL-79(D), ITC-350; RCA TK-76B(C), TK-86

\* Can be used with all REFLEX-20 batteries listed above; included is one "CB(B)" cable.

\*\* Two each batteries required for operation.

† Available through Ampex Corp.



**CAMRAPROMPTER**

**Cinema Products' unique film/video camera prompting system: low-cost, compact, light-weight, easy to set up and simple to operate!**

Mounted in a matte box-type enclosure, the Camraprompter\* utilizes a clear acrylic optical flat set at a 45° angle in front of the camera lens. The optical flat acts as a mirror reflecting the bright, easy-to-read script to the subject being photographed, with virtually no light loss to the lens.

A side-mounted light source is used to back-light the script "scroll." The script copy can be typed or hand-printed onto the matte-finish clear plastic 25-foot roll which is advanced by means of an ultra-silent, miniaturized motor drive.

A small remote control unit provides continuously variable speed control (forward or reverse). The remote control unit may be operated by the "on camera" subject or by the person in charge of pacing the sequence who is viewing the script roll from the side of the Camraprompter unit. Camraprompter is an ideal prompting system for documentary, educational or industrial assignments, and all applications generally shot on location.

\*Patents pending.

**Specifications**

- Bright, easy-to-read script information. Copy "frame" size 6 1/4" wide x 5" high.
- Copy can be typed or hand-printed on matte-finish plastic rolls (7" wide x 25' long).
- Small remote control unit (with 10' detachable cable) provides continuously variable speed control (forward or reverse).
- Ultra-silent, miniaturized motor drive.
- Side-mounted light source utilizes two standard fluorescent lamps (GE F4T5-CW).
- System includes a universal camera mounting plate for film and video cameras.
- Power: standard 12V battery pack or belt (1.75 amps max).
- Weight: Camraprompter (less universal camera mounting plate) weighs only 5 lbs. 12 oz. **\$2100.00**



**Camraprompter shown with 16mm camera**

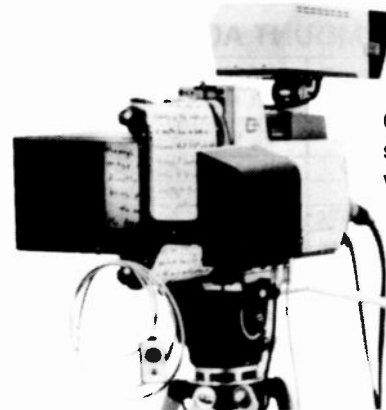

**Camraprompter shown with video camera.**

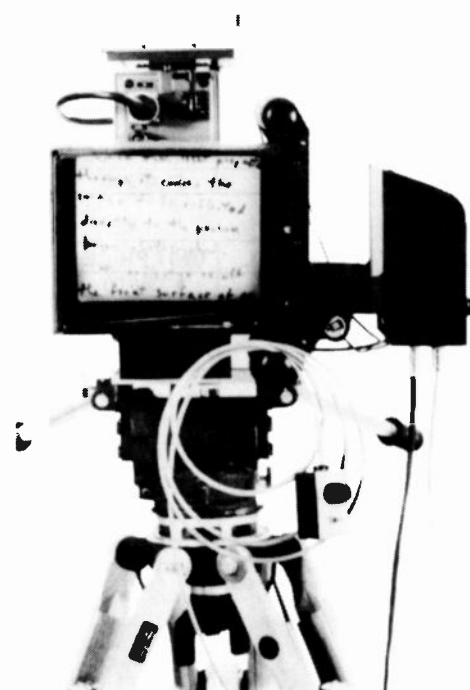

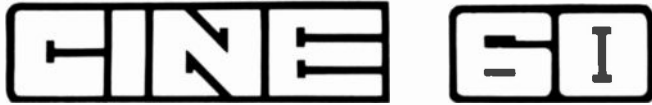

# POWERBELTS/PAKS AND ACCESSORIES

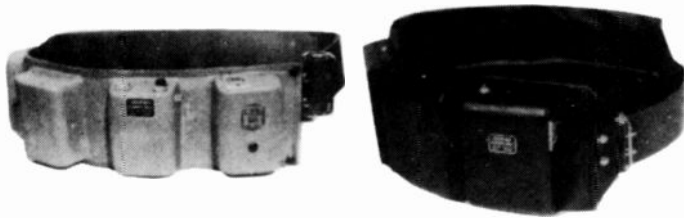

## STANDARD POWERBELTS

### 12 VOLT STANDARD POWERBELTS

**6307 12V.-4AH STANDARD POWERBELT** with built-in 115V Overnite Charger. Automatic Reset Circuit Breaker. 5-pin Canon XLR5-31 connector. Wt. 5.5 lbs. **\$375.00**

**7007 12V.-7AH STANDARD POWERBELT.** Higher capacity version of No. 6307. Wt. 7.5 lbs. **\$511.00**

**6327 12V.-8AH STANDARD POWERBELT** with built-in 115V Overnite Charger. Automatic Reset Circuit Breaker. Charge/Use Switch. 5-pin Canon. Wt. 10 lbs. **\$571.00**

**7027 12V.-14AH STANDARD POWERBELT.** Higher capacity version of No. 6327. Wt. 14 lbs. **\$890.00**

### + 12V./-12V. STANDARD POWERBELTS

**6311 + 12V./-12V.-4 AH STANDARD POWERBELT** with built-in 115V. Overnite Charger. Automatic Reset Circuit Breaker. 5-pin Canon connector. Wt. 10 lbs. **\$565.00**

**7011 + 12V./-12V.-7 AH STANDARD POWERBELT** with built-in 115V. Overnite Charger. Automatic Reset Circuit Breaker. 5-pin Canon connector. Wt. 14 lbs. **\$880.00**

### + 14.4V./-14.4V. STANDARD POWERBELTS

**6315 + 14.4V./-14.4V.-4 AH STANDARD POWERBELT** with built-in 115V. Overnite Charger. Automatic Reset Circuit Breaker. 5-pin Canon connector. Wt. 11.5 lbs. **\$630.00**

**7015 + 14.4V./-14.4V.-7 AH STANDARD POWERBELT** with built-in 115V. Overnite Charger. Automatic Reset Circuit Breaker. 5-pin Canon connector. Wt. 15 lbs. **\$940.00**

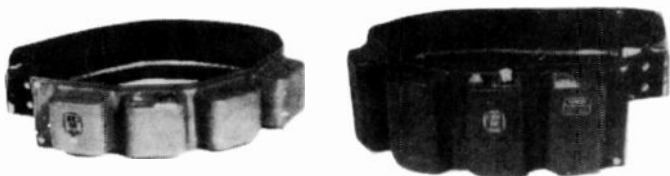

## FAST CHARGE POWERBELTS

### 12 VOLT FAST CHARGE POWERBELTS

**8307FC 12V.-4AH 1 HOUR FAST CHARGE POWERBELT** with built-in 115V. Overnite Charger. Automatic Reset Circuit Breaker. 5-pin Canon connector. Fast Charge Circuitry. Requires 9400 Fast Charger to FC in one hour. **\$415.00**

**8327FC 12V.-8AH 1 HOUR FAST CHARGE POWERBELT** with built-in Overnite Charger. Automatic Reset Circuit Breaker. Charge/Use Switch. 5-pin Canon. Fast Charge Circuitry. Requires 9400 Fast Charger to fast charge in one hour. Wt. 10 lbs. **\$611.00**

### + 12V./-12V. FAST CHARGE POWERBELT

**8311FC + 12V./-12V.-4 AH 1 HOUR FAST CHARGE POWERBELT** with built-in 115V. Overnite Charger. Automatic Reset Circuit Breaker. Fast Charge Circuitry. 5-pin Canon connector. Requires Model 9400 Fast Charger to fast charge in one hour. **\$595.00**

### + 14.4V./-14.4V. FAST CHARGE POWERBELT

**8315FC + 14.4V./-14.4V.-4 AH 1 HOUR FAST CHARGE POWERBELT** with built-in 115V. Overnite Charger. Automatic Reset Circuit Breaker. Fast Charge Circuitry. 5-pin Canon connector. Requires Model 9400 to fast charge in one hour. **\$660.00**



## STANDARD POWERPAKS

### 12 VOLT STANDARD POWERPAKS

**9107 12V.-4AH STANDARD POWERPAK** with external 115/230V. Overnite Charger. Automatic Reset Circuit Breaker. 5-pin Canon. Sh. Strap. Wt. 4 lbs. **\$410.00**

**9707 12V.-7AH STANDARD POWERPAK.** Higher capacity version of No. 9107. Wt. 6 lbs. **\$542.00**

**9127 12V.-8AH STANDARD POWERPAK** with built-in 115V. Overnite Charger. Manual Reset Circuit Breaker. Charge/Use Switch. 5-pin Canon Sh. Strap. Wt. 9 lbs. **\$605.00**

### + 12V./-12V. STANDARD POWERPAKS

**9111 + 12V./-12V.-4 AH STANDARD POWERPAK** with built-in 115V. Overnite Charger. Manual Reset Circuit Breaker. 5-pin Canon connector. Sh. Strap. Wt. 9 lbs. **\$620.00**

**9711 + 12V./-12V.-7 AH STANDARD POWERPAK** with built-in 115V. Overnite Charger. Manual Reset Circuit Breaker. 5-pin Canon connector. Sh. Strap. Wt. 13 lbs. **\$916.00**

### + 14.4V./-14.4V STANDARD POWERPAKS

**9115 + 14.4V./-14.4V.-4 AH STANDARD POWERPAK** with built-in 115V. Overnite Charger. Manual Reset Circuit Breaker. 5-pin Canon connector. Sh. Strap. Wt. 11 lbs. **\$670.00**

**9715 + 14.4V./-14.4V.-7 AH STANDARD POWERPAK** with built-in 115V. Overnite Charger. Manual Reset Circuit Breaker. 5-pin Canon connector. Sh. Strap. Wt. 14 lbs. **\$940.00**



## FAST CHARGE POWERPAKS

### 12 VOLT FAST CHARGE POWERPAKS

**9107FC 12V.-4AH 1 HOUR FAST CHARGE POWERPAK** with external 115/230V. Overnite Charger. Automatic Reset Circuit Breaker. Fast Charge Circuitry. Requires 9400 Fast Charger to FC in 1 hour. **\$450.00**

**9127FC 12V.-8AH 1 HOUR FAST CHARGE POWERPAK** with built-in 115V. Overnite Charger. Manual Reset Circuit Breaker. Charge/Use Switch. 5-pin Canon. Fast Charge Circuitry Shoulder Strap. Requires Model 9400 Fast Charger to fast charge in one hour. Wt. 9 lbs. **\$645.00**

**9727 12V.-14AH STANDARD POWERPAK.** Higher capacity version of No. 9127. Wt. 13 lbs. **\$890.00**

### + 12V./-12V. FAST CHARGE POWERPAK

**9111FC + 12V./-12V.-4 AH 1 HOUR FAST CHARGE POWERPAK** with built-in 115V. Overnite Charger. Manual Reset Circuit Breaker. Fast Charge Circuitry. 5-pin Canon connector. Sh. Strap. Requires Model 9400 Fast Charger to fast charge in one hour. **\$660.00**

### + 14.4V./-14.4V. FAST CHARGE POWERPAK

**9115FC + 14.4V./-14.4V.-4 AH 1 HOUR FAST CHARGE POWERPAK** with built-in 115V. Overnite Charger. Manual Reset Circuit Breaker. Fast Charge Circuitry. 5-pin Canon connector. Sh. Strap. **\$700.00**

# CINE 60

## SUN-GUN KITS



The 12V. Sun-Gun Kit consists of: The Cine 60 Sun-Gun Head (with integral Swing-Away Filter Holder, removable handle, integral battery cable), Cat. No. 6201A; Tungsten-Halogen Lamp, 11.5V. 100 Watt, Cat. No. 6211; Swing-Away Dichroic Filter, Cat. No. 6202; Battery Cable Adapter, Cat. No. SG6512; 12V. SG Powerbelt or Powerpak, Standard or Fast Charge; Overnite Charger; Carrying Case Cat. No. 6207. Pictured: 12 V. 8AH Fast Charge Powerbelt Sun-Gun Kit with 1 Hour Fast Charger.

Cat. No. SGK-8327PS

SGK6307PS	12 VOLT 4AH STANDARD POWERBELT SUN-GUN KIT. 25 minute life. Wt. 15lbs.....	\$735.00
SGK-7007PS	12 VOLT 7AH STANDARD POWERBELT SUN-GUN KIT. 40 minute life. Wt. 17lbs.....	\$852.00
SGK-6327PS	12 VOLT 8AH STANDARD POWERBELT SUN-GUN KIT. 50 minute life. Wt. 20lbs.....	\$904.00
SGK-8307PS	12 VOLT 4AH FAST CHARGE POWERBELT SUN-GUN KIT. 25 minute life. With 9400 Fast Charger. Wt. 18lbs.....	\$1,016.00
SGK-8327PS	12 VOLT 8AH FAST CHARGE POWERBELT SUN-GUN KIT. 50 minute life. With 9400 Fast Charger. Wt. 23lbs.....	\$1,187.00
SGK-7027PS	12 VOLT 14AH STANDARD POWERBELT SUN-GUN KIT. 80 minute life. Wt. 23lbs.....	\$1,180.00
SGK-7027FC	12 VOLT 14AH FAST CHARGE POWERBELT SUN-GUN KIT. 80 minute life. With 9400 Fast Charger. Wt. 26lbs.....	\$1,452.00
SGK-9107PS	12 VOLT 4AH STANDARD POWERPAK SUN-GUN KIT. 25 minute life. Wt. 14lbs.....	\$775.00
SGK-9107FC	12 VOLT 4AH FAST CHARGE POWERPAK SUN-GUN KIT. 25 minute life. With 9400 Fast Charger. Wt. 17lbs.....	\$1,055.00
SGK-9707PS	12 VOLT 7AH STANDARD POWERPAK SUN-GUN KIT. 40 minute life. Wt. 16lbs.....	\$880.00
SGK-9127PS	12 VOLT 8AH STANDARD POWERPAK SUN-GUN KIT. 50 minute life. Wt. 19lbs.....	\$934.00
SGK-9127FC	12 VOLT 8AH FAST CHARGE POWERPAK SUN-GUN KIT. 50 minute life. With 9400 Fast Charger. Wt. 22lbs.....	\$1,215.00
SGK-9727PS	12 VOLT 14AH STANDARD POWERPAK SUN-GUN KIT. 80 minute life. Wt. 23lbs.....	\$1,180.00
SGK-6304PS	30V.-4AH STANDARD POWERBELT SUN-GUN KIT. 25 minute life. Wt. 21lbs.....	\$880.00



The 30V. Sun-Gun Kit consists of: The Cine 60 Sun-Gun Head, Cat. No. 6201A; Tungsten-Halogen Lamp, 30V. 250 Watts, Cat. No. 6209; Swing-Away Dichroic Filter, Cat. No. 6202; 30V. SG Powerbelt or Powerpak, Standard or Fast Charge, Overnite Charger; Carrying Case, Cat. No. 6207.

Pictured: 30V. 4AH Fast Charge Powerpak Sun-Gun Kit with 1 Hour Fast Charger.

Cat. No. SGK-9104FC

SGK-8304PS	30V.-4AH FAST CHARGE POWERBELT SUN-GUN KIT. 25 minute life. With 9400 Fast Charger. Wt. 24lbs.....	\$1,158.00
SGK-7004PS	30 VOLT 7AH STANDARD POWERBELT SUN-GUN KIT. 40 minute life. Wt. 23lbs.....	\$1,179.00
SGK-7004FC	30VOLT 7AH FAST CHARGE POWERBELT SUN-GUN KIT. 40 minute life. With 9400 Fast Charger. Wt. 26lbs.....	\$1,465.00
SGK-9104PS	30V.-4AH STANDARD POWERPAK SUN-GUN KIT. 25 minute life. Wt. 21 lbs.....	\$906.00
SGK-9104FC	30V.-4AH FAST CHARGE POWERPAK SUN-GUN KIT. 25 minute life. With 9400 Fast Charger. Wt. 24 lbs.....	\$1,187.00
SGK-9704PS	30V.-7AH STANDARD POWERPAK SUN-GUN KIT. 40 minute life. Wt. 23 lbs.....	\$1,204.00
SGK-9704FC	30V.-7AH 2 HR. FAST CHARGE POWERPAK SUN-GUN KIT. 40 minute life. With 9400 Fast Charger. Wt. 26 lbs.....	\$1,472.00

Prices and Specifications Subject to Change Without Notice.



# CINE 60 Sun-Gun Light

Cine 60's Sun-Gun is a unique battery powered light used by TV camera men and documentary film makers all over the world as a "fill" light outdoors, a "key" or "fill" light indoors. For 30 Volt 150, 250, 350 watt and 12 Volt 100 watt tungsten-halogen lamps. Features: Soft, Wide Angle Focusing Light ideal as a camera mounted light in head-on situations. At 10 ft. Flood Position throws a 14 ft. wide beam flat from edge to edge, free of hot spots, filament patterns, or halos. Lets camera man achieve better picture quality, balancing "fill" light to ambient light, and eliminating harsh facial shadows. A heat-insulated knob on back is used to focus, sliding in and out and locking at any point from maximum to minimum beam width. Built-In Swing-Away Dichroic Filter, 3400°K indoor color temperature or 5500°K color temperature with the turn of a knob.

# VIDEO ACCESSORIES

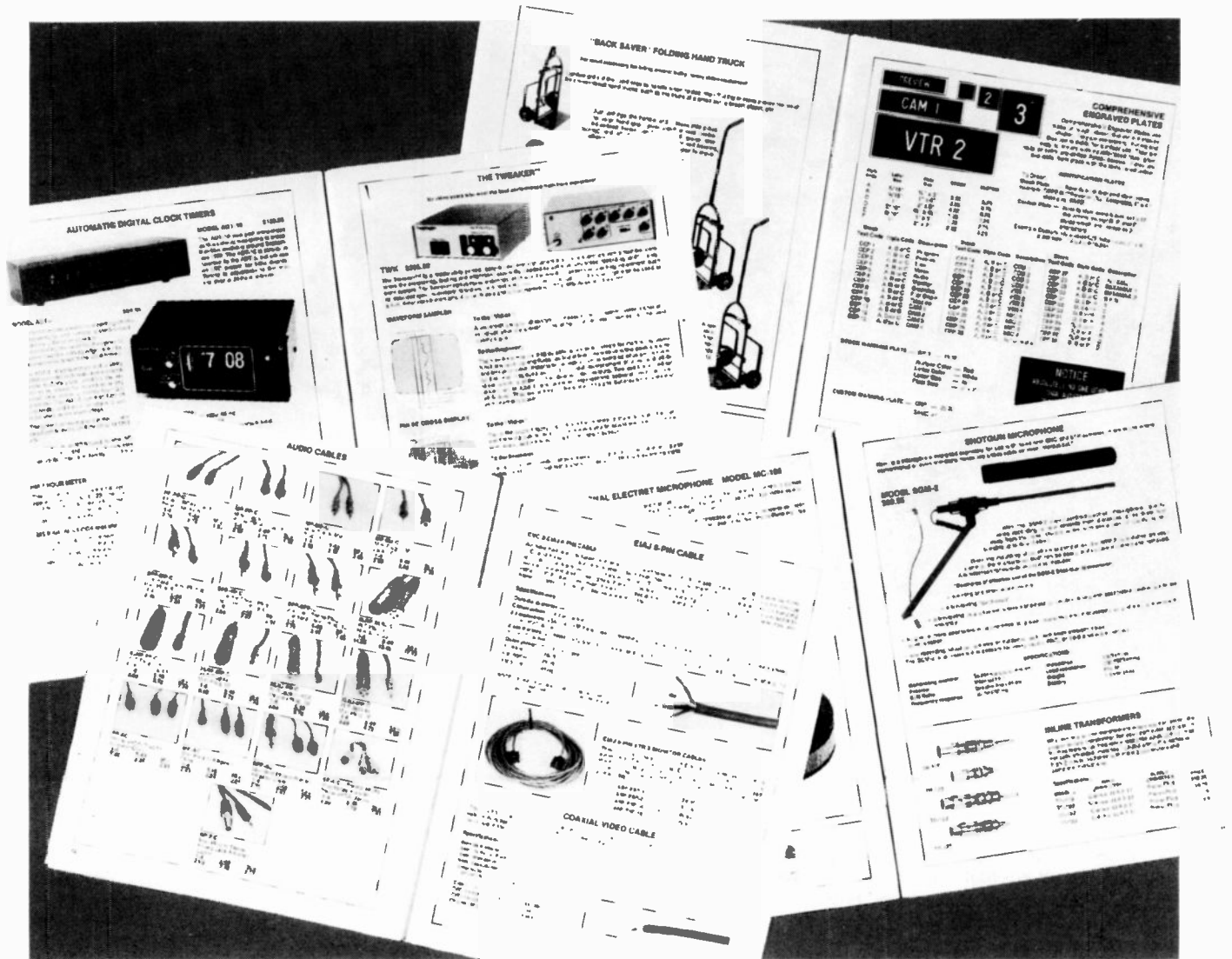

Call Or Write  
For The  
**Comprehensive Video Supply Center**  
Catalog

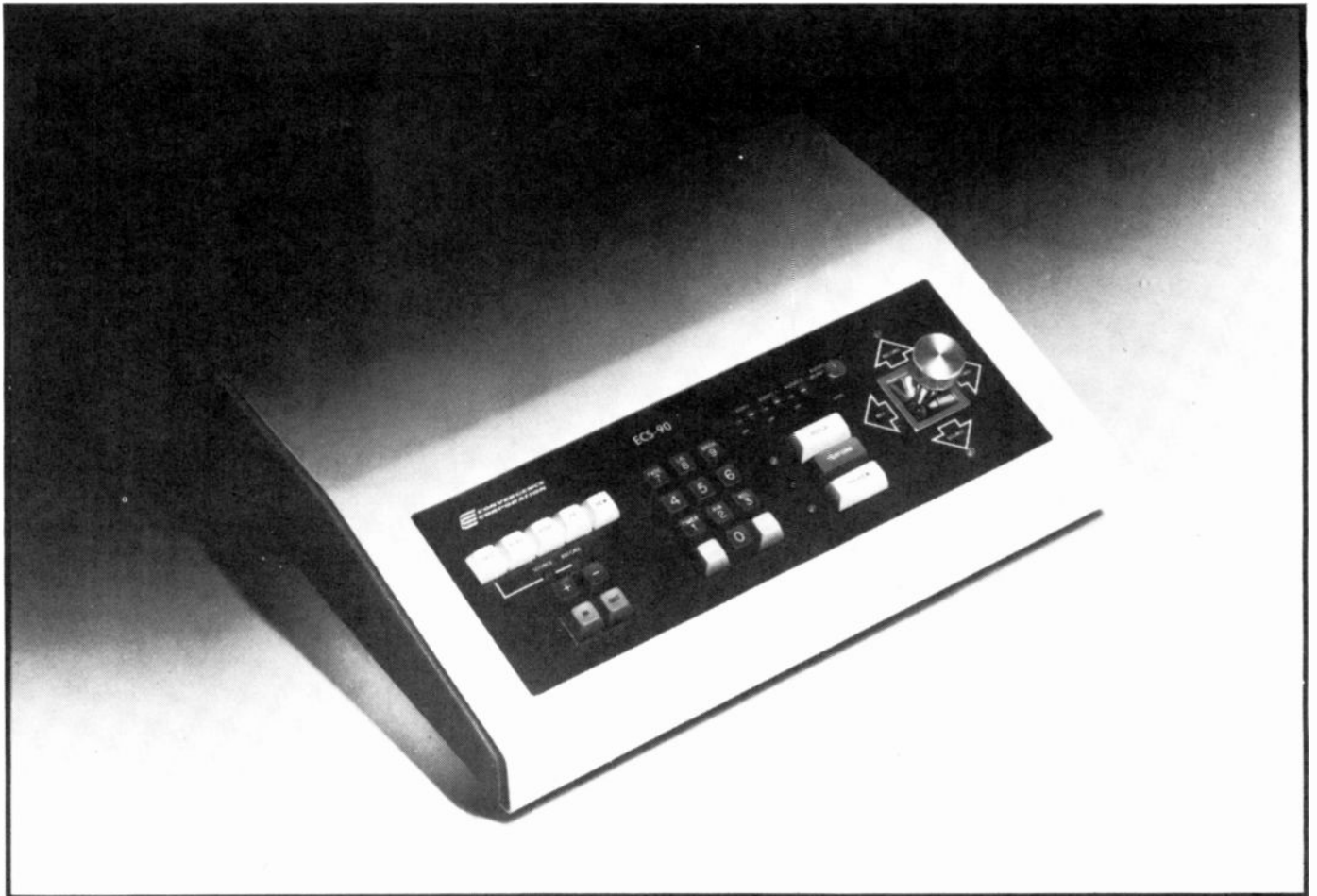
**ECS-90 EDITOR**
**\$4250.00**

Convergence Corporation, the proven leader in video tape editing technology, brings you the speed, simplicity and convenience of joystick editing at a very affordable price.

Whether you're in industrial, educational, broadcast or post-production television, you can benefit from the versatility and low cost of this powerful new system.

Advanced features include:

- Fully variable joystick control of tape speeds
- Preview, perform and replay of edits
- Interchangeable VTR formats
- Independent control of audio and video channels
- Programmable high-speed search
- Mark-in/out on the fly
- CRT display of edit data
- Programmable pre- and post-rolls
- Full VTR remote control
- Auto tag
- Control track or optional SMPTE time code

Here's an editor you can start with and stay with. And it protects your hardware investment by easy installation with your present VTR's. New direct plug-in interface connects to industrial ½ inch cassette and ¾ inch U-matic format recorders with absolutely no modifications.

Discover the new low price of high-quality editing.

**ACCESSORIES:**
**TCR-90 Two-channel Time Code Reader**

Reads pre-recorded longitudinal SMPTE/EBU time code from two sources. Includes IOA-90 parallel input/output assembly for interconnect to ECS-90, and one Operation and Maintenance Manual. **\$2,000.00**

**IFS-90/2860 High Speed Module**

Option for use with CCA-90/2260/2860 HS Kit for greater than play speed joystick operation. **\$50.00**

**SPK-90 Spare Parts Kit**
**\$300.00**
**PLUG-IN OPTIONS:**
**LL-90 Liplock Audio Pitch Corrector**

Corrects audio pitch to provide intelligible auto monitoring when tape is joysticked at faster or slower than normal speed. **\$1,200.00**

**BL-90 BLADE™, black generator and fade module**

Fades up from and/or down to black at in or out edit points. Includes internal black burst generator for prerecording color black on video tapes. (Fade NTSC and PAL, Black Burst Generate NTSC only). **\$1,100.00**

**CCA-90 Control Cable Assembly**

Specify VTR manufacturer and model number

**\$600.00**

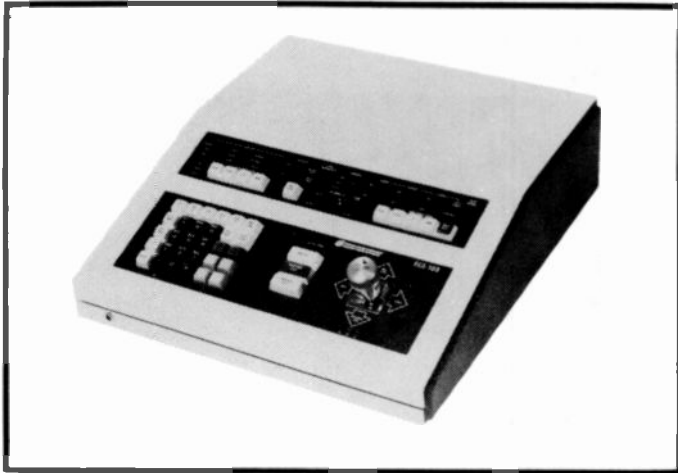

### ECS-103 (A, B and C) Superstick Multi-Source Editing System

Includes Superstick panel with Cruise Control, Auto Tag, Replay, Automatic Return to Edit, Transport Controls, Adjustable Preroll, Automatic Audio Monitoring with built-in speaker amplifier, Record Mode Controls and Accessory Controls. Also includes Full Keyboard for selection of multiple input sources on optional switcher, Programmable Fast Wind Tape Search, manual Tag, Split Edit Controls, Store and Recall of 100 scene locations. Edit Trim Register, SDG-100 Status Display Generator and two 1/4" interfaces. Call or write for complete ECS-103 Accessory List.

#### Prices for ECS-100 Series Editors

- ECS-103A (has the full 103 keyboard, split audio-video edits, scene store and recall, high-speed search, effect notation for off-line editing and B and C source VTC capability for cuts only editing) **\$10,500.00**
- ECS-103B (same as the 103A except capable of A-B roll edits, special effects, switcher control, and can mix formats between 1" and 3/4" VTR's), including 3 interfaces **\$19,000.00**
- ECS-103C (has additional capability of list management and auto-assembly, includes expanded program memory and RS-232 serial port, 3 interfaces and EDL Board) **\$24,500.00**

### ECS-104

"Human-engineered" is a phrase that takes on new meaning with ECS-104 List Management Edit Controller — the easiest to learn and easiest to operate editing system on today's market. List management and operating features you hoped would be available "someday" are standard right now in every ECS-104. They combine critical edit accuracy with unprecedented editing flexibility, making it possible to produce air-ready master tapes with maximum creativity, minimum time.

The ECS-104's unique standard features include:

EDL-100 Edit Decision Lister provides serial EIA RS-232C signal-level output of editing information for listing on printer, tape punch or other device.

JoyScrol™ — lets you edit from pictures and sound, searching up and down, with the list automatically following the VTR and always available, edit by edit, or by control of the joystick • TimeSearch™ — provides direct, automatic access of the list to any known time location on either the record or source tapes by a simple keyboard entry • "409" — the first time this industry-recognized clean-up process has been included as *standard* in any editing system • CleanIt™ — eliminates overlaps automatically to help keep the list clean as you edit, saving time as you go • SynTag™ — keeps multiple video and audio tape recorders perfectly synchronized to maintain continuity of edits when doing a sync roll • CheckIt — starts automatically when power is turned on to verify proper operation of all programs within the system • TenCom™ — provides 10 relay contact closures (and corresponding logic levels); user assigns time and sequence of closures to control external devices such as effects generators, recorders, character generators, etc. with respect to any selected VTR. (Requires the CG-100 Command Generator option.) • AutoMatch™ — allows the operator to match the source and record VTR in-edit points at any location within the precious edit, with one keystroke • Action-Match™ — automatically calculates the required edit points to match action or sound anywhere in an edit sequence. Audio only or video only inserts can be precisely matched to proper action or sound with the Superstick and a single keystroke. **\$36,000.00**

### ECS-104S List Management Editing System

TCR100 Time Code Reader, (includes 3 reader cards) and three 1/4" Interfaces (1" Interfaces can be substituted for 3/4" interfaces at additional cost.) The ECS-104S provides a complete control system at greatly reduced prices, includes EDL100 **\$42,400.00**

#### Options and Accessories for ECS-100 Series Editors

LL-100 Liplock Audio Pitch Control Provides intelligible audio monitoring when tape is joysticked at faster or slower than real time speed **\$1800.00**



TCR-100 Time Code Reader System Reads prerecorded longitudinal SMPTE/EBU time code from two VTRs. Expandable up to four VTRs with optional RC-100 Plug-in module. Includes: Rack frame with plug-in modules: PS-100 Power Supply, MX-100/TC Multiplexer, (2) RC-100 Time Code Reader Module; ICC-100/20 twenty foot accessory interconnect cable with connectors and PIO-100 Parallel Input/Output Module **\$4500.00**

RC-100 Time Code Reader Module Plugs into TCR-100 Time Code Reader system. One module required for each VTR added. Includes: Plug-in module and connector **\$800.00**

ARC-100 Animate Remote Control Provides control to ECS-100 Series animate function from remotely located manual or automatic animate table. Box with 15' control cable and connector **\$2000.00**

EDL-100 Edit Decision Lister Provides serial EIA RS-232 signal level output of editing information to be listed on customer supplied printer, tape punch or other device. Consists of SIO-100 Serial Input/Output plug-in module and output connector (included with ECS-103C) **\$1500.00**

SE-100 Editing Switcher/Effects System A dedicated five-inputs, two-buss audio follow video switcher and special effects system for two-source cut/dissolve/key or wipe with 46 patterns including soft wipes. Transitions are programmable from ECS-103 keyboard (Must be used in system with TCR-100 Time Code Reader System. All VTR inputs must be time base corrected.) (For ECS-103 Series only) Includes: 7" frame. PS-100 Power Supply and system plug-in modules; ICC-100/5' and ICC-100/20' accessory interconnect cables and JB-100 Junction Box for system interconnect to ECS-103 Console **\$9500.00**

ME-110 Editing Mix/Effects System enables the professional editor to add 23 different standard effects patterns (wipes, dissolves, etc.) and key transitions up to 255 frames via the ECS-104 editing keyboard. **\$11,000.00**

CP-110 Control Panel extends the ME-110's capabilities by enabling manual override of automatic functions (through its own keyboard and expanding programmable transitions to 999 frames, allowing variable transition rates. **\$3,000.00**

ME-110/CP-110 **\$13,500.00**

#### Update Kits to convert an existing

to convert an existing	to an	Requires	Price
ECS 103A	ECS-103B	CK-103AB	9500.00
ECS 103A	ECS-103C	CK-103AC	14,500.00
ECS 103C	ECS-104	CK-104	12,500.00
ECS 103B	ECS-103C	CK-103BC	5500.00

AVS-100 Audio Video Switcher (Not used in systems with SE-100) A dedicated Five-Input/One-Output video switcher with audio follow. All inputs selected at ECS-103 keyboard. Includes: 3 1/2" Rack mount unit with internal power supply and A/V Switch Module, ICC-100/5' and ICC-100/20' accessory interconnect cables and JB-100 Junction Box for system interconnect to ECS-103 Console. (Must be used in system with TCR-100 Time Code Reader System) **\$2000.00**

AVS-100X Audio Video Switcher (Not used in systems with SE-100) Same as AVS-100 except includes PIO-100 Parallel Input/Output Module for systems which do not include TCR-100 Parallel Input/Output Module for systems which do not include TCR-100 Time Code Reader System **\$2500.00**

SWI-110 Universal Switcher Interface **\$3000.00**

#### Interface Packages

IFP-100	1/4" and 3/4"	1500.00
IFP-100	1" Type E and C and Ampex	2500.00
IFP-100/ATR	Audio	3000.00



# CCTV LENSES



## FOR 2/3 INCH VIDICON CAMERA

Model No.	Focal Length	Relative Aperture	Type	Note
	mm	F		
C418X	4.8	1.8	Manual	Fixed Focus Ultra Wide Angle
C815-2	8.5	1.5	Manual	
C1616A-2	16	1.6	Manual	
C1616DNR	16	1.6	Manual	W/O Diaphragm
C815ES	8.5	1.5	Auto Iris	For Silicon Camera V.S. or V DC 9V ~ 18V
C815AE	8.5	1.5	EE Lens	DC 6V
C1616AES	16	1.6	Auto Iris	For Silicon Camera V.S. or V DC 9V ~ 18V
C1616AE-2	16	1.6	EE Lens	DC 6V
C6Z1218	12.5 ~ 75	1.8	Manual	
C6Z1218ES	12.5 ~ 75	1.8	Auto Iris	For Silicon Camera V.S. or V DC 9V ~ 18V
C6Z1218M2ES	12.5 ~ 75	1.8	Motorized Auto Iris	For Silicon Camera V.S. or V DC 9V ~ 18V
C10Z1120M2ES	11 ~ 110	2.0	Motorized Auto Iris	For Silicon Camera V.S. or V DC 9V ~ 18V

## FOR 2/3 & 1 INCH VIDICON CAMERA

B618AX	6.5	1.8	Manual	Fixed Focus Ultra Wide Angle
B815A	8.5	1.5	Manual	Ultra Wide Angle
B1214A	12.5	1.4	Manual	
B1218	12.5	1.8	Manual	
B2514C	25	1.4	Manual	
B2519-2	25	1.9	Manual	
B5014	50	1.4	Manual	
B5018A-2	50	1.8	Manual	
B7514	75	1.4	Manual	
B1214AES	12.5	1.4	Auto Iris	For Silicon Camera V.S. or V DC 9V ~ 18V
B1214DE	12.5	1.4	EE Lens	DC 6V
B2514CES	25	1.4	Auto Iris	For Silicon Camera V.S. or V DC 9V ~ 18V
B2514CE	25	1.4	EE Lens	DC 6V
B5018AES	50	1.8	Auto Iris	For Silicon Camera V.S. or V DC 9V ~ 18V
B5018AE-2	50	1.8	EE Lens	DC 6V
B4Z2215A	22.5 ~ 90	1.5	Manual	
B4Z2215AM2	22.5 ~ 90	1.5	Motorized Zooming, Focusing & Iris	DC 6V
B4Z2215AM2EL	22.5 ~ 90	1.5	Motorized Auto Iris	For Silicon Camera V.S. or V DC 9V ~ 18V

### Optional Accessories:

X2 range extender, Extension tube set, Wall bracket, Microscope adapter and Close-up attachments are separately available as well as remote control boxes for Motorized zoom lenses.

### Remarks: Symbols in Model No.

**ES** : Automatic Diaphragm for Silicon Vidicon Camera  
**M2** : Motorized-Zooming, Focusing

**E** : Automatic Diaphragm (EE)  
**N** : Without Diaphragm.  
**X** : Fixed Focus.

Prices and specifications subject to change without notice



## VIDEO AND AUDIO PRODUCTS

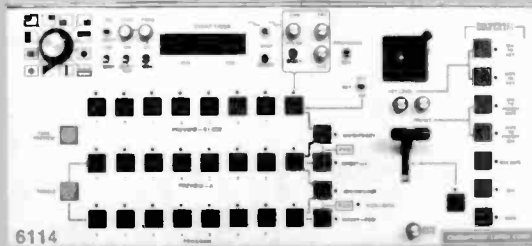

**Model 6114** Eight input (including colorizer) three bus video switcher, 12 patterns, positioner, event timer, pattern modulator, soft wipe, spot lite, blink key, toggle, take preview, automatic or manual mix and wipe, blanking processor, non-sync lamp, loop thru video input, black burst output. Includes extender board. **Price \$4680. PAL \$5680.**

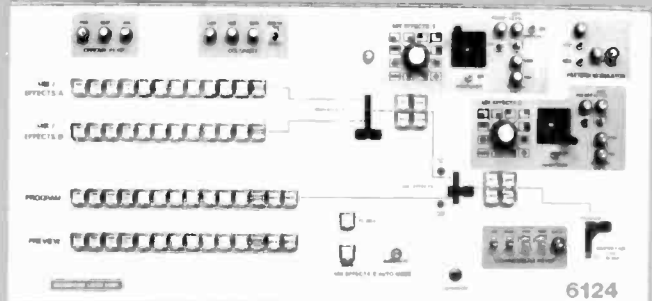

**Model 6124** Four bus, twelve input (including colorizer) video switcher with two fully independent mix effects systems, downstream keyer, encoded chromakeyer, pattern modulator, automatic or manual mix and wipe, colorizer, dual pattern generators with positioners, loop thru video inputs, take preview, toggle, adjustable soft and border effects, intercom, spot lite, dual back porch clamps, black burst output, blanking processor, master fade to black. Includes extender board and rack slides on electronic package. Control panel 30 x 14". **Price N.T.S.C. \$13,700. PAL \$14,700.**

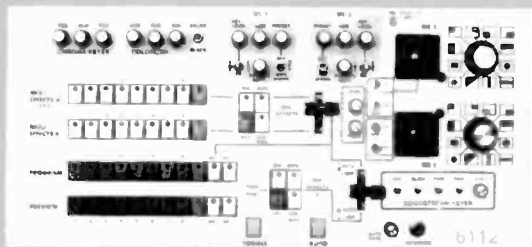

**Model 6112** Four bus, nine input (including colorizer), video switcher with two fully independent mix effects systems, downstream keyer, pattern modulator, automatic or manual mix and wipe, colorizer, dual pattern generators with positioners, loop thru video inputs, take preview, toggle, adjustable soft and border effects, intercom, spot lite, dual back porch clamps, black burst output, blanking processor. Includes rack slides for electronics package and extender board. **Price N.T.S.C. \$7,950. PAL \$8,950.**

### 6112 Options

Encoded chroma keyer (plug in board)	<b>\$1,050.</b>
RGB chroma keyer (plug in board)	<b>\$1,050.</b>
Slimline control panel (4 inches)	<b>\$250.</b>
Relay Board	<b>\$150.</b>
Pulse Lock Module to enable 6112 for genlocking to input #1	<b>\$850.</b>

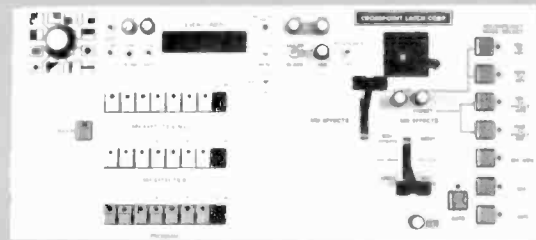

**Model 6142** Eight input, (including colorizer) three bus video switcher, with 12 patterns, dual fader handles enables double re-entry, positioner, variable soft timer, pattern modulator, spot lite, blink key, toggle, take preview, automatic or manual mix and wipe, blanking processor, mix to effects, loop thru video inputs, black burst output. Includes extender board. **Price \$5245. PAL \$6245.**



**Model 6107** Six input, (including colorizer), two bus video switcher, 12 patterns, positioner, automatic or manual mix and wipe, soft wipe, full preview, intercom, tally, blanking processor, loop thru video inputs, black burst output. Includes extender board. **Price N.T.S.C. \$3,800. PAL \$4,800.**



**Model 6118** Six input (including colorizer) three bus video switcher with 12 patterns, positioner, soft wiper, colorizer, key, super, and blanking processor. Genlocks to inputs 1 or 5 (internally selectable) and provides all six drive outputs and black burst. Input #5 genlocks to VTR. **Price \$2995.**

**6118 Option** Automatic camera lock module - for use with Sony 16"0 or 1640 and JVC G71US color cameras - automatically drives and times up to 4 cameras - Sony cameras do not need CMA-6. **Price \$850.**

## VIDEO AND AUDIO PRODUCTS

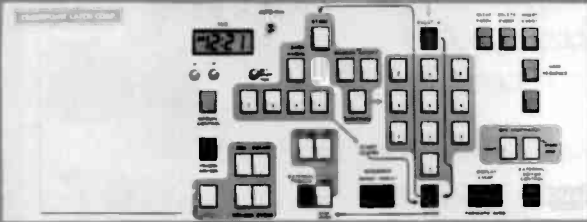

**Model 7200** AUTO DRIVE™ is a programmable computer controller for the 6124 and 6112 switchers. The unit is capable of storing the entire configuration of the control panel of the switchers as an "event". Its solid state memory has a capacity for 255 events. AUTO DRIVE™ can produce abrupt or smooth transitions between events controlling analog functions smoothly from one event configuration to the next. Events can be set for duration times from 1 frame to 3 minutes for "smooth" and 1 frame to 99 minutes for "abrupt". AUTO DRIVE™ can even learn manual fader handle operations and reproduce it precisely. **Price \$12,500.**

### 7200 Options

Video Media Z6E Interface	<b>\$3,000.</b>
Datatron Interface	<b>\$3,000.</b>
Convergence Interface	<b>\$3,000.</b>



**Model 6024** Full Field color bar generator and background colorizer, one output each, two black burst outputs. **Price \$1150.**

### 6024 Option

Remote control panel.	<b>\$143.</b>
-----------------------	---------------



**Model 6025** Color background generator with two black burst outputs. **Price \$990.**

### 6025 Option

Remote control panel.	<b>\$143.</b>
-----------------------	---------------

**Model 6026** Encoded Chroma Keyer and Video mixer. 1 3/4" rack mountable, horizontal positioner, dual outputs for midstream and downstream chroma keying. **Price \$3,500.**

**Model 6027** Fade To Black Generator 1 3/4" rack mountable. With a built-in 2 input mixer, includes remote panel. **Price \$1,500.**

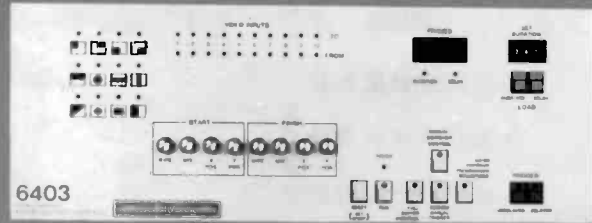

**Model 6403** Programmable Editor Switcher Interface allows most Crosspoint Latch switchers to communicate directly with editors. It handles one ME on the switcher. The 6403 controls the position as well as the size of the patterns, permitting wipes and mixes from one preset limit to another preset limit, to be performed with frame accurate precision. It also has a delay counter permitting delayed effects. The maximum duration and delay times is 1000 frames. The 6403 can either be totally controlled from the more sophisticated editors (by means of the optional EDITOR MODULE) or it can be triggered from even the simplest editors by means of an intercept box which plugs directly into the connector on the record VTR. **Price \$2750. Editor module (where required) \$995.**

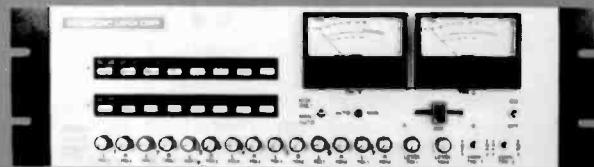

**Model 6800** PROGRAMMABLE AUDIO MIXER with 7 inputs and a built in 1 KHz time generator balanced inputs and outputs. There are two channels per input (stereo). The two channels may be reversed or combined into either of the two outputs. The 6800 interfaces with editors and can be programmed remotely to perform cuts and mixes with duration times from 1 to 1000 frames. Input 7 may be internally jumpered to double as a "voice over input; (an external mic. amplifier is necessary). **Price \$3,500.**

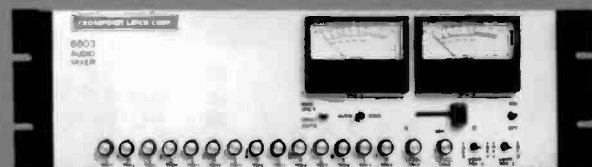

**Model 6803** AUDIO FOLLOW SWITCHER for the 6112, 6107, and 6124 switchers. 7 balanced inputs (stereo). Gain may be either manually or externally controlled. Balanced outputs, which may be reversed or combined. Input 7 may be internally jumpered to double as an "voice over" input; (requires an external mic. amplifier). **Price \$2,500.**

## VIDEO AND AUDIO PRODUCTS

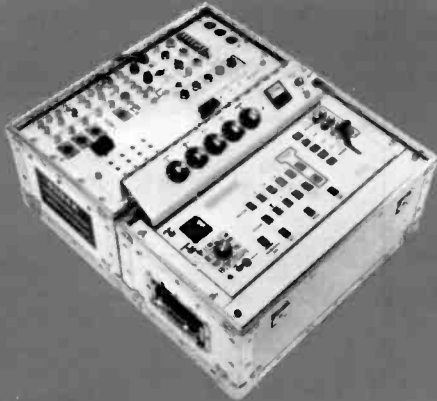

**Model 6104A**

**PORTABLE VIDEO PRODUCTION SYSTEM.** This is a video and audio switching console built into a rugged and portable carrying case, which can be shipped by air as baggage. It operates from both 11V AC as well as from an external 12 volt battery. It has a complete sync generator system capable of driving five cameras of any make or model. The sync distribution system, has five complete sets of drives, as well as five black burst outputs each of which is independently adjustable both for subcarrier as well as horizontal phase. Other important features include color bar generator, four input mic. mixer, very versatile six input switcher with automatic preview, auto and manual wipes. **Price \$10,700.**

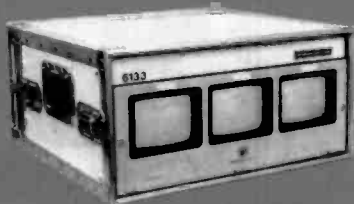

**Model 6133**

Three monochrome five inch monitors mounted in a portable carrying case, with single cable connection to the 6104A. The monitors are set to display Cameras 1, 2 and 3 on the switcher. **Price \$1565.**



**Model 6134**

Two monochrome and one color monitor package, connected to display the output of the 6104A console. Single cable connection to the 6104A. **Price \$2415.**

### SYNC GENERATORS WITH MULTIPLE OUTPUTS

- The 6006 series all have,
- 4 sync/horizontal drive outputs
- 5 subcarrier outputs
- 5 vertical drive outputs
- 2 each, blanking & burst flag
- 1 each additional sync & H. Dr.
- 2 Black Burst

There are four horizontal (sync or H. Dr.) and four subcarrier adjustments on the front panel

### IN ADDITION

The 6006A, 6006B and the 6006C all have genlock capability

The 6006B has four individually phase adjustable black burst outputs, with 360 degrees for burst and 2 microsecond range for horizontal. This enables four cameras to be adjusted from the sync generator panel. The two other black burst outputs allow two more genlock cameras to be driven from the unit. The other drives enables the switcher and other color and monochrome equipment to be driven without the need for other distribution amplifiers.

The 6006C has color bars and a 1 kilocycle tone generator.

**Prices:** 6006 \$1250; 6006A \$1590;  
6006B \$1990; 6006C \$1990.



**Model 6006**



**Model 6006A**



**Model 6006B**



**Model 6006C**



## AMPLIFIERS

### D-75 Power Amplifier

The Crown D-75 power amplifier, requiring only 1 3/4" (4.45cm) of vertical rack space, was designed to operate safely and continuously into a variance of load requirements. The D-75 provides 35 watts per channel minimum RMS (both channels operating) into an 8 ohm load over a bandwidth of 20Hz-20KHz at a rated sum total harmonic distortion that is 0.05% of the fundamental output voltage. The frequency response of the unit varies no more than +/-0.1dB from 20Hz-20KHz at 1 watt into 8 ohms. Features of the D-75 include active balanced inputs, Cannon XLR connectors, an easily accessible mono-stereo switch, and front panel LEDs indicating overloads and signal presence. A special feature of the D-75 is the provision for isolating chassis ground from electrical ground.



D-75  
\$489.00

### D-150A Single or Dual Channel Power Amplifier

The Crown D-150A is a single or dual channel power amplifier designed for precision amplification of frequencies from 1Hz to 20KHz. The design of the D-150A provides extremely low harmonic and intermodulation distortion with very low noise. A switch on the rear of the unit allows stereo or mono operation with no internal wiring changes. In the mono mode, the D-150A is capable of a 50 volt balanced line output. The unit operates on AC current from 120V to 240V.

The D-150A embodies the simplest and yet most accurate distortion display available in any audio product. The IOC — Input-Output Comparator — senses any form of amplifier non-linear behaviour and reports its existence through front panel LEDs. Slew-induced distortion, protection circuit activation, and clipping distortion will all be detected by the IOC circuit at levels below the rated distortion of the amplifier. Thus, the amplifier becomes a valuable tool in the hands of the user to facilitate proper amplifier-speaker-environment matching, as well as a continuous monitor of the purity of the signal reproduction through the amplifier under actual operating conditions.

Stereo Output: 80 W RMS per channel.



D-150A  
\$699.00  
HMB-5 optional handle kit  
\$20.00

### DC-300A Single or Dual Channel Power Amplifier

The Crown DC-300A is a single or dual channel power amplifier designed for precision amplification of frequencies from 1Hz to 20KHz. The design of the DC-300A provides extremely low harmonic and intermodulation distortion with very low noise. A switch on the rear of the unit allows stereo or mono operation with no internal wiring changes. In the mono mode, the DC-300A is capable of a 70V balanced line output. The unit operates on AC current from 120V to 256V.

The DC-300A embodies the simplest and yet most accurate distortion display available in any audio product. The IOC — Input-Output Comparator — senses any form of amplifier non-linear behavior and reports its existence through front panel LEDs. Slew-induced distortion, protection circuit activation, and clipping distortion will all be detected by the IOC circuit at levels below the rated distortion of the amplifier. Thus, the amplifier becomes a valuable tool in the hands of the user to facilitate proper amplifier-speaker-environment matching, as well as a continuous monitor of the purity of the signal reproduction through the amplifier under actual operating conditions.

The DC-300A contains output protection circuitry pioneered by Crown. This circuitry protects the unit completely against shorted, mismatched, or open loads and completely eliminates the need for DC fuses and mode switches to protect the amplifier. With this unique protection system, the DC-300A can safely drive any speaker load, resistive or reactive, with no fear of harming the amplifier. The speakers can be paralleled with no deterioration of sound quality since changing the load impedance only affects the maximum power available, not the ability of the amplifier to produce clean sound.

The DC-300A has two totally separate direct coupled amplifier circuits employing dual integrated circuit op amp input stages and silicon transistors in succeeding stages. The DC-300A exhibits essentially flat frequency and phase response down to DC and eliminates thumping from non-symmetrical wave forms. Output stages utilize Crown class AB + B circuitry in which the driver transistors carry the quiescent bias current while the output transistors serve only as boosters which sense and deliver large currents.

Stereo Output: 155 W RMS per channel.



DC-300A  
\$1099.00  
HMB-7 optional handle kit  
\$20.00

**datametrics**

**DRESSER**

## TIME CODE SYSTEM

Model 722A  
Reader/Generator/Character  
Generator with Video

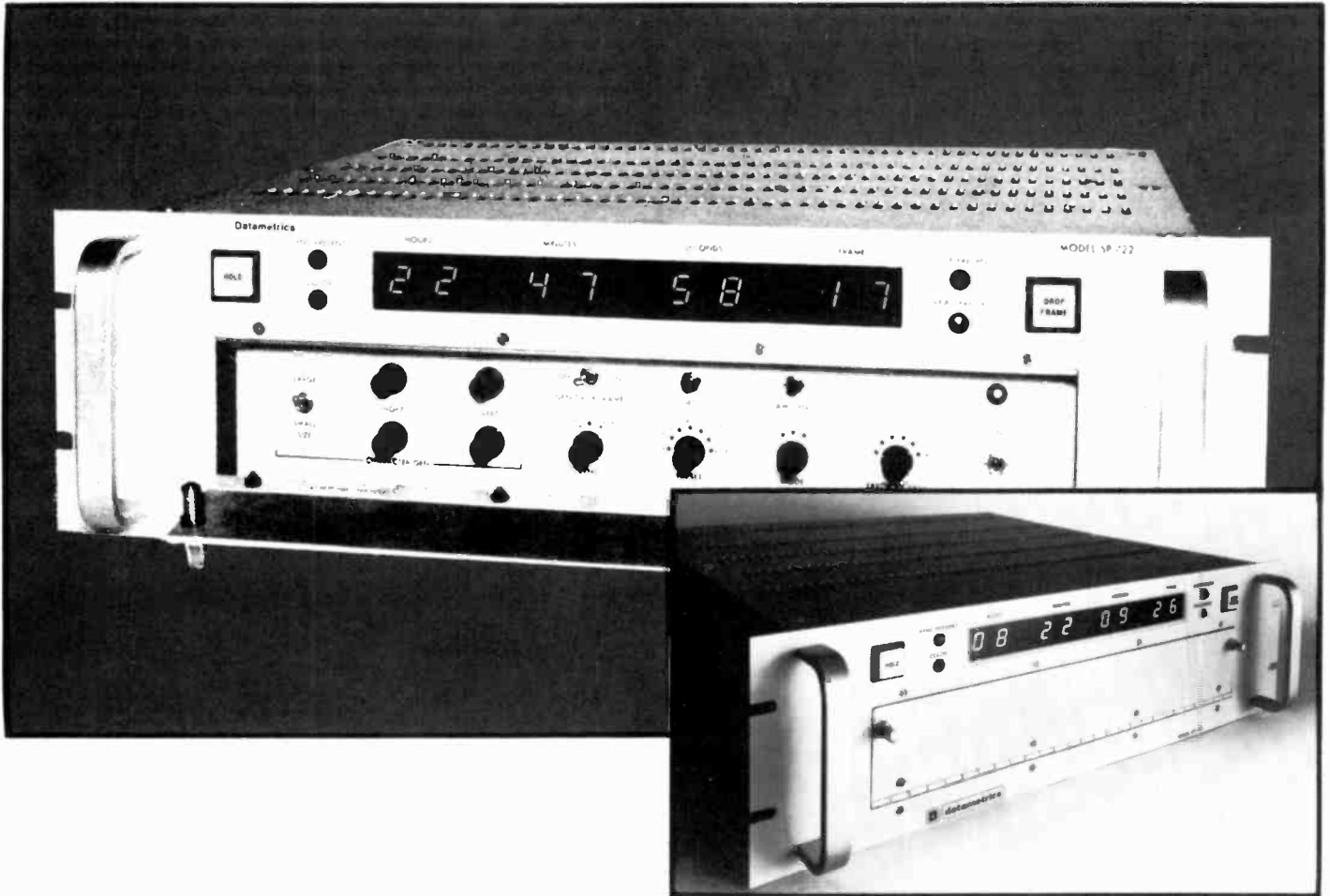

The Datametrics 722A SMPTE Time Code System was designed to provide complete generate, read and video display capabilities in one cost-effective package. It fits well in television studio and production environments, where a maximum of capabilities must fit in a minimum of space.

Complete code generation capabilities include the encoding of Time data in a Drop Frame or Non Drop Frame mode, plus the insertion of User data. Quick code preset is accomplished via a seven position rotary switch and pushbutton. Synchronization to video or crystal reference is an internal automatic feature.

The Model 722A can be selected to decode either Time or User data, incorporating reader features that overcome problems associated with faulty time code. Error by-pass enables the 722A to display and output frame accurate Time data in the presence of disrupted or inconsistent code words. The number of consecutive disregarded words is front-panel selectable. A wide dynamic input and bandwidth allow the 722A to read and display code from 1/20 to 100x VTR play speed. If deteriorated code is encountered, the 722A has complete regeneration capabilities via the Jam Sync mode, laying down accurate code with proper synchronization and timing.

Decoded time is displayed on a clearly legible front panel LED display. In addition, an internal character generator/video inserter will superimpose a character display upon video programming. Multi-size characters are fully positionable, and can be switched onto the vertical interval when needed. Adjustable character brightness and a switchable mask background add format versatility. Drop Frame mode is indicated by a three-dot colon between characters.

The Datametrics Model 722A includes parallel data outputs, selectable for Time or User data, allowing for remote display or computer editing system input.

The Datametrics Model 722A Time Code System is a cost-effective package for studio or production personnel looking for complete SMPTE code capabilities. It is packaged in an attractive case with recessed controls and front panel indicators for Code Present, Drop Frame Status, Sync Present, Hold mode, Time/User mode and error detection.

Model 722A  
Reader/Generator/Character Generator w/Video ..... \$4,950.00

# SMPTE TIME CODE READERS/GENERATORS/VIDEO INSERTERS

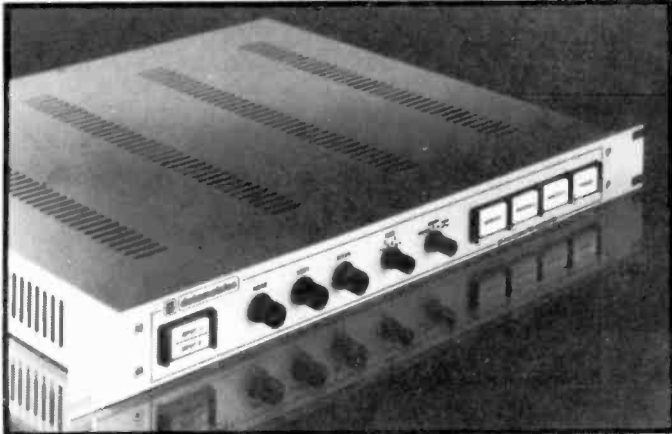

**SMPTE Character Generator Model 700** \$1,850.00  
 700 Features: • BCD Parallel Input • Keys Hexadecimal Characters on to Video Signal (O-F) • Low Cost



**SMPTE Time Code Reader Model 710** \$2,280.00  
 710 Features: • Low Cost • Wide Dynamic Input and Bandwidth • Integral Video Character Generator • Low Profile 1 1/4" x 19" Package



**SMPTE Code Reader Model 733** \$2,240.00  
 733 Features: • Time or User Data Operation • Hexadecimal Display and Output • Compact Size — Low Power • Compensated/Noncompensated Format Sensing • Automatic Direction Sensing • Full Input Speed Range

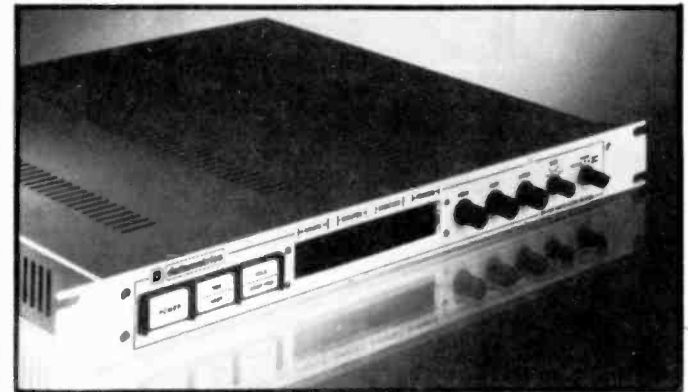

**SMPTE Time Code Reader Model 760** \$2,960.00  
 760 Features: • Wide Input Bandwidth • Reads Simultaneous Time and User Data • Integral Video Character Generator • Dot-Matrix — Hexadecimal Display • Low Profile — 1 1/4" x 19" Package

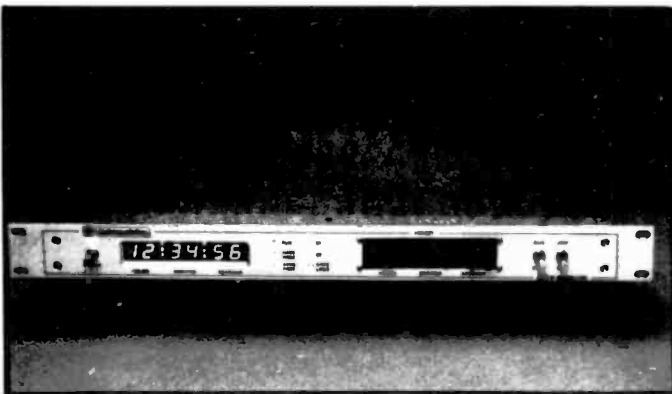

**Time Code Generator Model 716** \$2,280.00  
 Designed specifically for Television Studio and Production Environments. Display and output of SMPTE time codes, Internal Reader, Reference Sync inputs for video or film tach pulse, Drop Frame Mode, Jam Sync and Sync lock

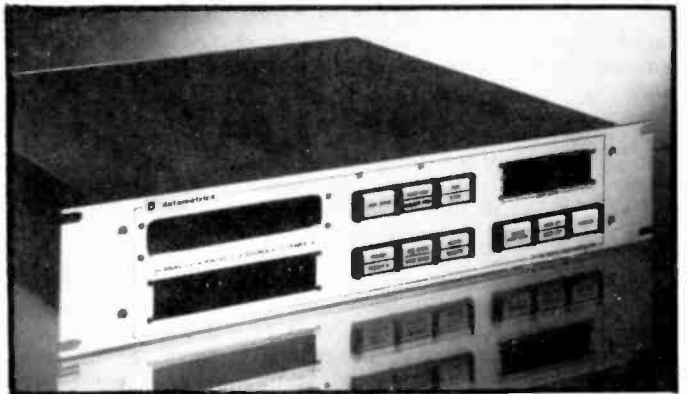

**SMPTE Code Generator Model 766** \$2,950.00  
 766 Features: • Generator Time and User Code • Internal or external Sync • Integral User Data Preset Switches • Fully Remote Controllable • Drop Frame Mode • Jam Sync Option • Real Time Clock Option

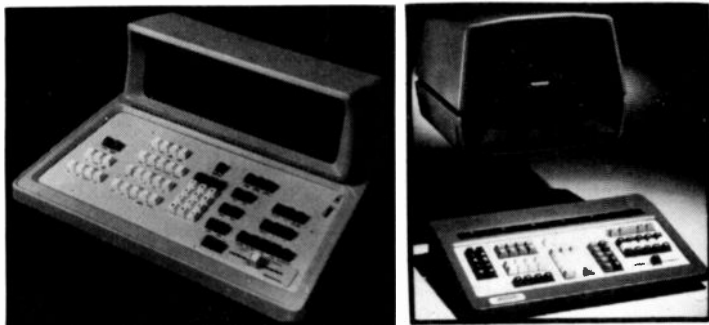

### TEMPO 76 EDITOR

- Frame-Accurate Editing
- Program Duration Display
- Event Duration Display
- VaraScan™ — Slow Motion, Reverse and Freeze-Frame Viewing
- Alphanumeric Self-Scan Panel Display by Burroughs Features Large, Easy-To-Read Character Display Panel with 80% Contrast Ratio
- Keypad Entry of Edit Parameter
- Edit Shift and Edit Trim
- Manual Preview
- Automatic Preview
- Automatic Edit
- Two Audio-Channel Edit Capability
- Audio, Audio/Video and Video Edit Selection
- Switcher Control
- Auto-Assembly
- Edit Decision Storage
- Text Edit Option
- A/B or B/A Rolls
- Special Memory to Speed-Up Succeeding Edits
- Edit Abort Logic
- Servo Sync of Two or Three VTR's
- Motion Control of One, Two or Three VTR's
- Automatic Search of One, Two or Three VTR's
- Extended Memory to 300 Events
- System Debug Option

The new Datatron TEMPO 76 Series is a high-performance, micro-processor-centered, expandable control system that takes advantage of integrated circuitry to provide state-of-art ease and flexibility in either Control Track and/or SMPTE Time Code editing modes.

The control center of the series is the TEMPO 76 Editor, featuring TIME SYNC\* and VARASCAN\*. The Editor can function equally well using standard SMPTE Edit Code or the standard Control Track pulses.

When using the standard SMPTE Edit Code, the code is recorded on one audio channel (usually the cue track) of the program material source tape and the electronically-edited master tape (EE master).

Since each recorded event coincides with a specific time value to the frame, TIME CODE makes it possible to locate any scene by running the tape to a designated time.

Similarly, when editing in a Control Track mode, pulses are recorded on the magnetic tape coincident with each field. By counting these pulses, TIME SYNC makes it possible to identify the actual frame of video information required to generate the (EE) master. Of course, control-pulse editing is not as consistent nor as accurate as SMPTE Time Code Editing.

With the TEMPO 76 Editor as a base, one can begin building his ultimate editing capabilities gradually with a two-VTR Time Sync or SMPTE System.

The TEMPO 76 Editor provides for automatic synchronization of video tape recorders (VTR's) and the precise transfer of information from a playback source to a "record" VTR.

### VANGUARD EDITOR

The Vanguard is a high-performance microprocessor based editing system uniquely suited for today's highly creative, cost conscious editing environment. It allows you to perform fast, accurate edits involving up to five VTR's and a switcher—on-line or off-line, SMPTE code or control track. It offers features and conveniences normally found only in expensive, top-of-the-line editing systems, including: an interactive CRT operator display and color coded dedicated function keyboard; adjustable operator reaction time compensation; selectable preroll and postroll times; dual Varascan™ shuttle controls; auto assembly; edit list management; and a large selection of VTR, ATR and film chain interfaces, just to name a few.

#### • TOTALLY FLEXIBLE VTR INTERFACING

Field-proven interfaces are available to allow the Vanguard to operate with a wide variety of VTR's, ATR's and film chains.

#### • OPERATES WITH A VARIETY OF SWITCHERS

Vanguard interfaces to a number of manufacturers' computer compatible switchers, including Datatron's own 2100E model.

#### • SMPTE CODE OR CONTROL TRACK OPERATION

Insert or assembly editing can be performed on the Vanguard using either SMPTE time code or control track pulses for tape position referencing (a SMPTE jam-sync generator is required to perform assembly edits in SMPTE mode).

#### • DUAL VARASCAN™ SHUTTLE CONTROLS

VTR's capable of variable speed play and shuttle modes can be controlled by Datatron's Varascan variable speed slider search control.

#### • MARK EDIT POINTS ON-THE-FLY OR KEYBOARD ENTER THEM

Edit-in and edit-out times can be marked on-the-fly from the time code being read from a moving tape, or they can be entered manually from the keyboard.

#### • FIVE TIER SCRATCHPAD MEMORY WITH TIME CODE CALCULATOR

The CRT scratchpad display can accommodate up to five memorized time code values entered from the keyboard.

#### • FULLY AUTOMATIC CUEING, PREVIEWING AND EDITING

The Vanguard offers fully automatic cueing, previewing and editing sequences involving up to three VTR's, plus a single VTR preview sequence.

#### • ON-THE-FLY (SYNC'D ROLL) EDITS AND PREVIEWS WITH UP TO FOUR SOURCES

Vanguard can perform edits and previews on-the-fly with up to four source VTR's rolling.

#### • UP TO 999 EVENTS OF EDIT LIST MEMORY WITH POWERFUL LIST MANAGEMENT

Vanguard can store up to 999 lines of edit events in its semiconductor memory; 320 events of memory come standard.

#### • AUTO ASSEMBLY FROM UP TO FOUR PLAY SOURCES

The entire edit decision list, or a designated block of it, can be automatically previewed or edited sequentially, pausing only when new reels must be mounted, or when a manual switcher setting is required.

#### • AN OPERATOR KEYBOARD AND DISPLAY THAT GUARDS AGAINST ERRORS

All editing functions of the Vanguard system are controlled by the operator from a desktop keyboard and CRT display.

#### • EDIT LIST INPUT/OUTPUT IN INDUSTRY-STANDARD FORMATS

The Vanguard can be equipped with several types of edit list input/output devices.



MODEL 5300



MODEL 5360

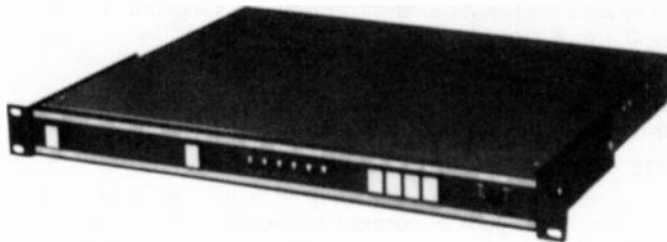

MODEL 5350

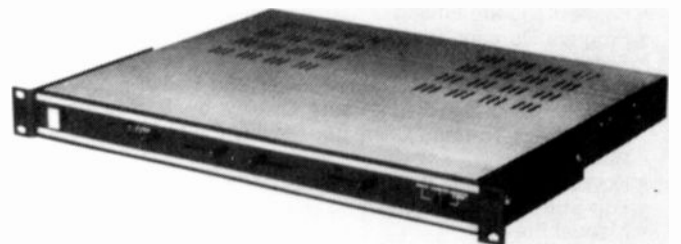

MODEL 5370

### 5300 SERIES INTELLIGENT TIME PROCESSORS

The Intelligent Time Processor will produce SMPTE/EBU time code simultaneously with user bits, vertical interval time code and video characters. The 5300 will operate in NTSC or in PAL.

A numeric key pad for data entry and high efficiency LED readouts combine to make for an attractive and highly functional front panel assembly.

The ITP reads standard serial code at speeds ranging from 1/3 to 90 times normal play speed in both directions without experiencing any frame decoding delay.

In addition the system will automatically revert to reading vertical interval time code when reading down to still frame to insure complete code reading reliability.

**MODEL 5300 STANDARD TIME CODE.** This Intelligent Time Processor will generate time code from data which is either preset through the front panel keyboard or dubbed from an external source. Special modes have been created which allow the 'user bits' portion of the code to update as an independent time generator or to be jam sync'd to serial time code from an external source. The ITP will also produce color frame correct time code.

**MODEL 5301 VERTICAL INTERVAL TIME CODE.** This is an optional feature that provides the ITP with the capability to both generate and read VITC in the proposed industry standard. Any two lines in the vertical interval from line 10 through and including line 20 can be selected. In the read mode, the ITP will decode VITC independently of its recorded position.

**MODEL 5302 TIME CODE CHARACTER GENERATOR.** The optional time code character generator makes use of a black mask background for either recording or displaying characters in the video picture. The vertical and horizontal positioning of the characters is controllable from the front panel, along with character height and width.

### 5350 SMPTE TIME CODE GENERATOR

The Datatron Model 5350 generates industry standard time code in SMPTE/EBU. Front panel thumb wheel switches allow for user-definable setting of hours, minutes and seconds. Additional user accessible front panel switches allow for such functions as drop frame/non-drop frame format, generator start and stop. Current time count is displayed through the use of LED indicators.

Time code serial output is at the rear chassis through standard balanced XLR connectors. Buffered parallel BCD code is also available.

A front panel indicator displays the presence of sync failure when it occurs. The Model 5350 and all of its features are combined in a standard 19" rack mount package requiring minimum space.

### 5360 SMPTE TIME CODE READER

The Model 5360 Time Code Reader will process SMPTE/EBU time code ranging in speed from 1/5 to 60 times normal play speed from any compatible source. The translated information is displayed in hours, minutes, seconds and frames through LED readouts. The hold feature allows the user to 'freeze' the display. A front panel lamp indicates the presence of drop frame/non-drop frame code.

To prevent the unit from translating invalid data the Model 5360 allows for the bypassing of one, two, four, or eight frames of code before the internal displays are updated. The time code reader rear panel has input facilities for balanced or non-balanced XLR input as well as buffered parallel BCD output.

### 5370 TIME CODE CHARACTER GENERATOR

Model 5370 is designed to superimpose up to eight SMPTE/EBU time code characters and three alpha characters on a standard video signal.

The numeric characters reflect the SMPTE/EBU time code in hours, minutes, seconds and frames. Additional rear connectors facilitate input for video background, composite sync and mixed output or characters.

Front panel switches and controls allow for character positioning of vertical and horizontal in addition to character height and width.



# DYNAIR ELECTRONICS, INC.

# SWITCHING EQUIPMENT

DYNAIR Series-X Switchers are pushbutton patch panels for distributing multiple monochrome or color video inputs (with optional audio-follow) to multiple outputs. Input amplifiers and output amplifiers are incorporated to provide isolation. A single input may be routed to any or all outputs simultaneously.

The switcher is available with either 6 or 12 inputs. Output units are individual modules which couple to the unit above. A single assembly of up to 12 outputs is easily constructed. If more than 12 outputs are desired, the looping video (and audio) input may be extended to one or more additional assemblies for up to 120 outputs.

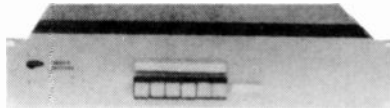

**VSX-6X1A \$775.00**  
**VSX-12X1A \$1050.00**

**VSX-6X1A thru VSX-12X12A**  
**VIDEO SPECIFICATIONS**  
Inputs: 6 or 12, 1.5 VPP maximum  
Input Impedance: High-impedance bridging  
Outputs: 1 to 12, channels, 1.5 VPP maximum, 75 ohm source-terminated, dual outputs  
Frequency Response: 30 Hz to 12 MHz,  $\pm 0.5$  dB  
Crosstalk: Better than 50 dB at 3.58 MHz, better than 40 dB at 12 MHz

Video Gain per Output. Variable -3 dB to +3 dB  
Tilt: Less than 1%  
Differential Gain: Less than 0.5%, 10:90 APL  
Differential Phase: Less than 0.5%, 10:90 APL  
Bounce on Output: DC coupled output video amplifier  
Hum and Noise: Greater than 60 dB RMS below 1-VPP output (30 Hz to 12 MHz)

**XD-6A**  
Output Expansion Unit, 6 input, for expanding VSX-6X1A up to 12 outputs. One XD-6A required per output.  
(basic price) **\$300.00**

**XD-12A**  
Output Expansion Unit, 12 input, for expanding VSX-12X1A up to 12 outputs. One XD-12A required per output.  
(basic price) **\$400.00**

The Series 10 Solid-State Video and Audio Switching Equipment provides 10-input/10-output high-quality vertical-interval monochrome or color video switching and on-air quality audio switching. Each 10x10 matrix is housed in a 5 1/4" H x 14 1/2" D x 19" rack mount chassis (13.34 x 36.83 x 48.26 cm) which includes power supply.

The control system is microprocessor-based and allows local and remote operation. Remote master and individual output bus control panels are available to operate over a single coaxial cable control line. Up to four levels of switching, 1 video and 3 audios as an example, can be controlled locally and/or remotely. A total of 15 remote control panels may be used to control a system.

Models SVA-100B, SVA-101B, SAA-110A and SAA-111A include 10 Form A tally relays and facilities to control the slave matrices, Models SVA-102B and SAA-112A.

**SAA-112A**  
Audio Switcher. Same as SAA-111A but for slave control only. Controlled from switcher control bus only. (Model CC-1130A Control Bus Jumper Cable Assembly not included.) Tally not provided. **\$2595.00**

**SCA-120A**  
Master Remote Control Panel, rack mounting. For remotely controlling all 10 outputs of video and/or audio switchers. **\$695.00**

**SVA-100B**  
Video Switcher, self contained, for local control. 10 input, 10 dual outputs with tally and regulated power supply. **\$3875.00**

**SVA-101B**  
Video Switcher. Same as SVA-100B but for remote control operation only. Control by single coaxial comm line. Requires remote control panel(s) options shown at right. **\$3675.00**

**SVA-102B**  
Video Switcher. Same as SVA-101B but for slave control only. Controlled from switcher control bus only. (Model CC-1130A Control Bus Jumper Cable Assembly not included.) Tally not provided. **\$3245.00**

**SAA-110A**  
Audio Switcher, self contained, for local control. 10 input by 10 output with tally and regulated power supply. **\$3225.00**

**SAA-111A**  
Audio Switcher, Same as SAA-110A but for remote control operation only. Control by single coaxial comm line. Requires remote control panel(s) options shown at right. **\$3025.00**

**TC-260A**  
75 ohm BNC Termination Plug for terminating looping video inputs. **\$6.00**



**SVA-100B**



**SAA-110A**



**SCA-130A**

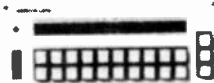

**CP-1100A**



**SVA-101B**



**SAA-111A**



**SCA-122A**



**SCA-131A**

**SCA-122A**  
Master Remote Control Panel, desk-top use. Same as SCA-120A except for housing. **\$895.00**

**SCA-130A**  
Single Bus Remote Control Panel, rack mounting. For remotely controlling 1 output of video and/or audio switchers. **\$500.00**

**SCA-131A**  
Single Bus Remote Control Panel, desk-top use. Same as SCA-130A except for housing. **\$500.00**

**CP-1100A**  
Basic Master Control Panel Assembly for conversion for local control operation of existing SVA-101B or SAA-111A. **\$300.00**

**BP-1109A**  
Blank Panel for video or audio switcher assembly for conversion for remote control with local status operation of SVA-100B or SAA-110A. **\$100.00**

**CC-1130A**  
Switcher Control Bus Jumper Cable Assembly. Allows control of slave matrix, Model SVA-102B and/or SAA-112A from SVA-100B or SAA-110A. **\$100.00**

**MB-1120A**  
Rack-mounting Chassis with power supply for housing Model CP-1100A Master Control Panel. **\$395.00**

**MB-1121A**  
Desk-top Chassis with power supply for housing Model CP-1100A Master Control Panel. **\$395.00**



### LARGE SCREEN MONOCHROME PROJECTION SYSTEM

#### EDP-57

Electrohome's Large Screen Monochrome Data/Graphics Display System has several new features which enhance performance and add to the ease of operation.

#### Product Features

- The EDP-57 has a new "Dynamic Focus" circuit which permits corner and center focus to be adjusted separately. In addition, this circuit helps to sharpen overall detailing.
- A new, aspherical f1.0 lens improves both the focus and crispness of data/graphics information from the EDP-57.
- A simple, accurate "one knob" optical focus control is conveniently located on the rear control panel.
- A 6 ft. screen, elevating legs, pedestal base, desk stand, ceiling mount, interface module and coaxial cable are accessories for the EDP-57 projection system.

#### Specifications

##### Brightness

- 100 foot-lamberts peak on axis on a 5' diagonal 10 gain screen • 100 lumens total light output (Std. P1 Phosphor)



#### Display

- Green P1 phosphor standard, other phosphors available on special order • Throw distance approx. 1.2x screen diagonal size • Continuously focusable from 4' diagonal projected picture to 10' diagonal
- Aspect ratio 3:4 • Keystone circuitry to correct picture for projection angles up to +/- 15° vertically from screen axis

#### Video Circuits

##### Input

- 2 BNC connectors (looped through) • 75 ohms +/- 1% terminated
- 25k ohm shunted by 12pf open • input level 0.5 to 2.0 volts p-p sync negative • differential (floating) input rejects 14 volts p-p of power line hum voltage • Horizontal frequency 11 kHz to 24 kHz
- Vertical Frequency 45 to 85 Hz

##### Frequency Response

20MHz bandwidth +/- 3dB

##### D.C. Restoration

- Back porch keyed clamp internally switchable to sync tip clamp

##### Gain

- Min. video gain 40dB or 100X • Max video output 110V p-p drive

#### Power requirements

- 120 VAC +/- 10% can be internally reconnected for 220 VAC +/- 10% or 240 VAC +/- 10% • Line Frequency 50 or 60 Hz nominal
- Power 120 watts max.

EDP-57 Projection System .....	\$4995.00
IM-56 Interface Module including Wiring Harness .....	232.00
PB-56 Pedestal Base .....	400.00
DS-56 Desk Base (Requires a Ceiling Mount)	
MY-56 .....	178.00
MY-56 Ceiling Mount .....	70.00
VS-56 Curved 6 ft. Screen .....	443.00
EL-56 Elevating Legs .....	103.00

# ELECTROHOME

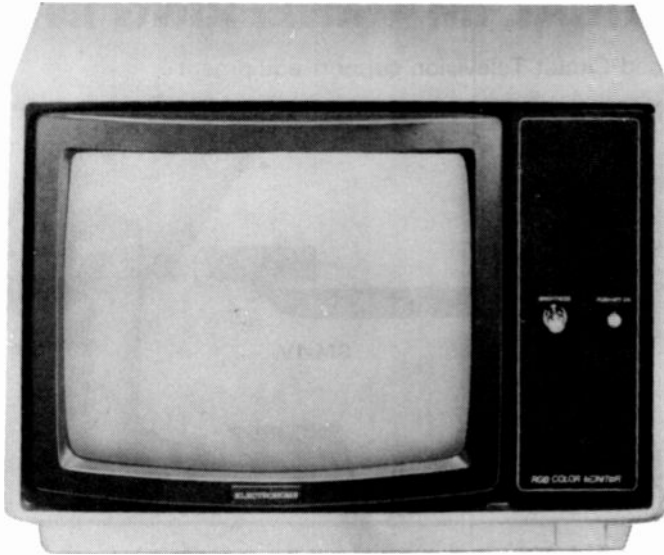

ECM 1302-1    ECM 1302-2

## MONITORS/ MONITOR RECEIVERS

### Color Video Monitor

Electrohome's new ECM 1302 Color Video Monitor is designed and built to international performance standards. It is a high reliability color video display unit designed to meet user needs in the personal computer market. Neatly styled, the new Electrohome color monitor has an attractive moulded cabinet. It is an RGB (TTL) monitor and will operate on NTSC with an optional interface module. Variety of personal computer interfaces available.

#### ECM 1302-1 (Medium Resolution)

• Resolution: 370 x 235 Pixels • CRT: 370 ESB 22 • Video: Bandwidth: 6 MHz • 80 Characters x 24 Lines Display    \$559.00

#### ECM 1302-2 (High Resolution)

• Resolution: 580 x 235 Pixels • CRT 370 JSB 22 • Video: Bandwidth: 10 MHz • 80 Characters x 25 Lines Display    \$978.00

### Color Television Receiver/Monitor

#### C50-090

#### RS 170 Input and Direct RGB

Electrohome's new 19" colour receiver/monitor was developed to provide access for individual red, green and blue (RGB) video information and external Composite Video signals in addition to standard broadcast TV video signals.

The Unit features RF input through the antenna for coarse video detail, RS 170 input for Composite Video (medium detail), and direct RGB inputs for highly detailed video. The tuner composite output provides for Teletext decoding and VTR recording.

Finally, there are two TTL control inputs. The first allows rapid switching between Composite Video and RGB pictures, providing "Picture-in-Picture" or Telidon "transparent mode" capability. The second allows remote switching between standard TV operation and external video viewing.    \$972.00

### Monochrome Data Monitors

Electrohome's international reputation for video display products with an extra degree of excellence has been further extended to include monitors specially designed for the personal computer market. The EDM-926 (9-inch) and EDM-1226 (12-inch) designs, both offering P-4 White and P-31 Green phosphors as standard, demonstrate Electrohome's awareness to user needs. Advanced electronic technology and design innovation are combined to provide crisp, clean character displays with excellent resolution on either 9 or 12-inch models. Performance, reliability and long life standards demanded by the data market, are inherent in these smartly styled units. Computer compatible design makes the EDM-926 and EDM-1226 ideal companions for compact, professional data displays of computer generated information

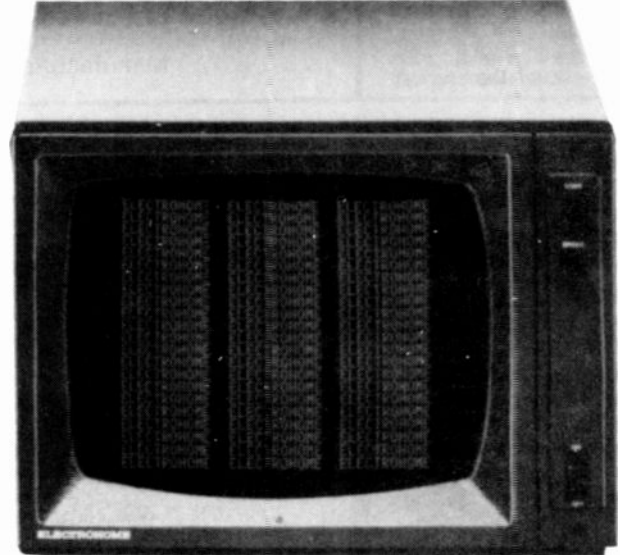

EDM1226

#### Product Features:

• 18 MHz frequency response • 750 line resolution • Simplified operator controls • Rear controls — externally adjustable to permit scan adjustment from 85% to 105% of CRT size • Standard case monitors may be single or twin rack mounted — 8.75" (22.2 cm) • Cabinets constructed of heavy gauge metal • P31 - green phosphor

EDM-926	9" Monitor	\$230.00
EDM-926P31		248.00
EDM-1226	12" Monitor	295.00
EDM-1226P31		312.00

### High Performance Monochrome Monitors

#### Product Features:

• Front operated A — B switching • 18MHz bandwidth • Scanguard\* circuit for size stability • Primary and major secondary controls front accessible • Internal/External sync capability • Excellent black level stability • Common mode rejection • AC cord winder (9", 12", 15", 17") • Switchable power supply for 110/220/240 volt operation • Universal AC interlock • Long life LED pilot light • Wide variety of options.

\*Scanguard is a special Electrohome development for EVM 19/20 models to keep picture sizes constant over a wide range of brightness changes.

EVM-920	9" Monitor	\$500.00
EVM-1220	12" Monitor	573.00
EVM-1519	15" Monitor	620.00
EVM-1719	17" Monitor	647.00
EVM-2319	23" Monitor	839.00
EVM-2319AG	23" Anti-Glare Monitor	873.00

#### Accessories

ECM-2	Ceiling Mount for 26" Educator	\$ 72.00
ECM-3	Ceiling Mount for 25" and 23" Models	72.00
EWM-1	Wall Mount Adaptor for ECM-2 and ECM-3	65.00
EMS-3	Mobile Stand	174.00
RAK-9A	9" Rack Mounting Kit	63.00
WMA-9	Waveform Mounting Kit for use with RAK-9A	30.00
RAK-12	12" Rack Mounting Kit	63.00
RAK-15	15" Rack Mounting Kit	67.00
RAK-17	17" Rack Mounting Kit	67.00

#### Options

Anti-Glare CRT (if used in EVM-920, High Resolution CRT must be used)	49.00
Audio Kit	81.00
P-31 Phosphor-green	65.00
High horizontal scan 18.5-22.5 kHz (Specify exact freq.)	98.00



# ELECTRO-MECHANICAL IMAGING INC.

Manufacturers of Closed Circuit Television support equipment

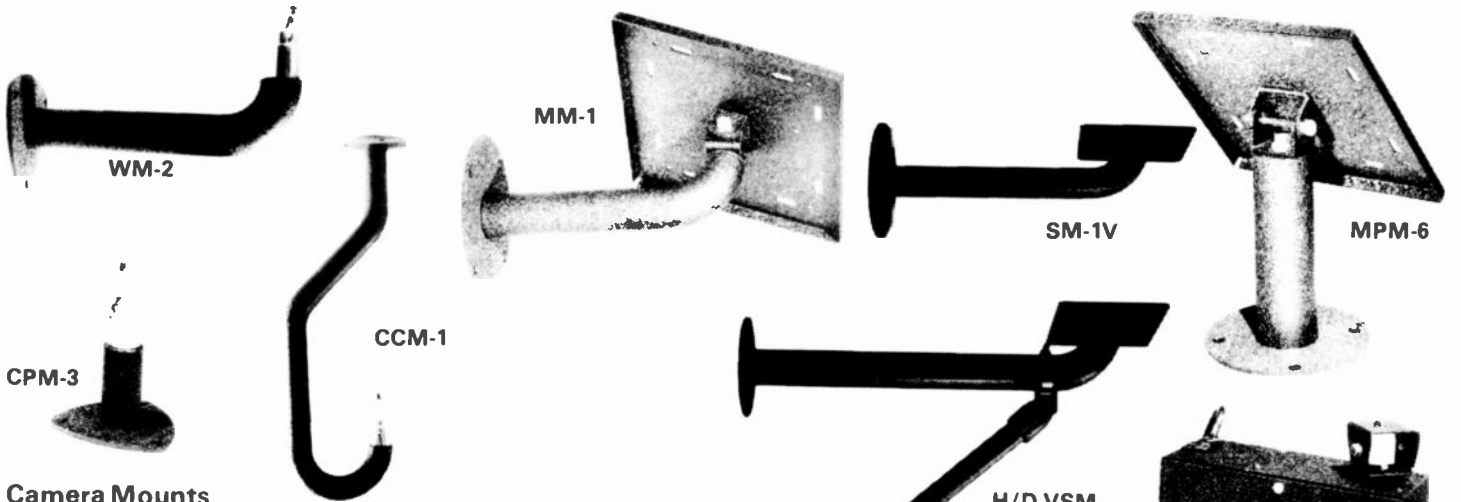

## Camera Mounts

WM-2	9 1/2" Wall / Ceiling Mount with universal head
WM-1P not shown	Same as WM-1 but for mounting on a pole
CPM-3	6" Pedestal Mount with universal head
CPM-6	9" Pedestal Mount with universal head
CCM-1	Camera Ceiling Mount with universal head

## Monitor Mounts

MM-1	9" to 12" Monitor wall mount with pan-tilt head
MPM-6	9" to 12" Monitor 6" pedestal mount w/pan-tilt head
MCM-2	9" to 12" Monitor ceiling mount with pan-tilt head

## Scanner and Pan-Tilt Mounts\*

H/D VSM w/strut	Heavy Duty VICON scanner and p/t mount w/strut
H/D VSPM-6	6" Heavy Duty VICON scanner, p/t pedestal mount
L/D VSPM-6	6" Light Duty pedestal mount for VICON scanners and pan/tilts or PELCO PS-5 scanners
SM-1V	Scanner wall mount for L/D VICON scanner and p/t or PELCO L/D PS-5 scanner
SC-100	Light Duty indoor scanner

## Tamper Proof Environmental Camera Housings

SCH-1	INSIDE Dimensions (19" L x 6 1/4" W x 7 1/4" H)
SCH-2	INSIDE Dimensions (19" L x 6 1/4" W x 4 1/4" H)
SCH-3	INSIDE Dimensions (17" L x 3-7/8" W x 6-1/8" H)
SCH-4	INSIDE Dimensions (15" L x 5-1/8" W x 3 1/2" H)

Sun Shields available for above housings

## Housing Mounts

HM-1	12" Medium Duty wall mount w/pan-tilt head
HM-2 not shown	16" Heavy Duty wall mount w/pan-tilt head
HM-2P	Same as HM-2 but for mounting on a pole
SHM-1	Same as HM-1, w/"TAMPER PROOF" cover and screws
SHM-2	Same as HM-2, w/"TAMPER PROOF" cover and screws
HCM-2	Housing Ceiling Mount with pan-tilt head
HPM-6	8 1/2" Housing Pedestal Mount with pan-tilt head

## H/D VSM-CB

Heavy Duty Vicon/Pelco scanner and p/t mount, for mounting on the corner of a building.

## BS-3

A new Swivel Head TAMPER PROOF Ball Socket which adjusts or locks with one allen set screw. Designed for tamper proof CCTV camera mounts, the BS-3 can be adapted to almost any equipment that requires a wide range of movement such as microwave alarms, welding, service or maintenance fixtures. By removing the washer and stud, a 20-pound load can be bolted to the ball top.

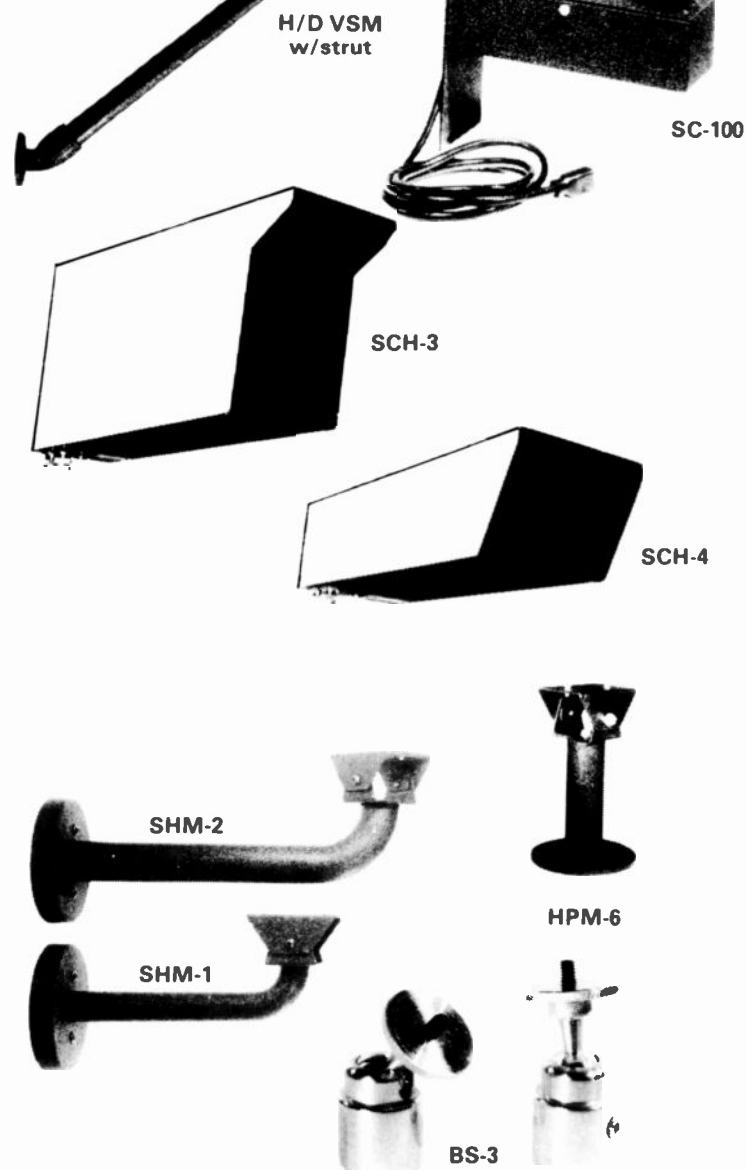

# EQUIPTO ENCLOSURES

These quality features make  
Equipto cabinets, desks and enclosures  
your best investment . . .

## EQUIPTO MODULAR ELECTRONIC DESK SYSTEMS

Made in two heights, seven widths  
and designed to meet virtually any  
equipment or instrumentation  
requirement.



**EQUIPTO INSTRUMENT/EQUIPMENT  
CABINETS . . .**clean, contemporary  
modular styling. 60 stock sizes,  
unlimited "custom" sizes in  
8 standard colors or any custom color.

## CHALLENGER COMMERCIAL DUTY MODULAR ELECTRONIC CABINET SYSTEMS

- Modular Design
- All welded construction
- Recessable panel mounting angles
- Mar-Proof panel mounting screws
- Standard EIA mounting angles

**MIL Spec**

## EQUIPTO HEAVY-DUTY MODULAR ELECTRONIC CABINET SYSTEMS

- 14-gauge, cold rolled steel, multi-formed channel
- Heli-arc welded for rigidity, durability
- 12-gauge pontoon base transmits load directly and safely to floor
- 3/16" EIA mounting angles for more than adequate support of heavy equipment
- 16-gauge cold rolled steel doors and panels are recessed for improved protection of instrumentation
- Structural design eliminates twist, sway and deflection

**MODULAR DESIGN** This means you can literally "custom achieve" any required configuration and eliminate the high cost of custom design and manufacture.

**DETAIL** Every visible and invisible detail in the design and manufacture of our cabinets and desk units reflects our commitment to produce the very finest available . . . anywhere.

**EQUIPTO QUALITY** Engineered and manufactured by the most experienced personnel in the electronic enclosure field.

Finished to your colors at no extra charge. Ask about our engineering evaluation program.

Call Equipto now and talk to our consulting engineers. Our phone s (312) 897-4691. Or write for our free catalogs.

## EQUIPTO ELECTRONICS CORPORATION

# ESE

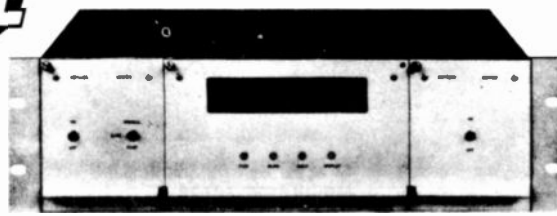

ESE Masters provide a means of keeping all time displays in the system in agreement, through the use of a Serial Time Code. Only one pair of wires is needed to distribute the time code to all remote serial input displays.

An ESE Master Clock System can operate digital displays, clocks with sweep second hands, printers and, in addition, tell your computer what time it is. Twelve hours of standby battery operation is standard in ES 160, 160/1 and 190.



## 780 SERIES RAM TIME PROGRAMMERS \$1200 to \$1500

When programming more than eight events, the 780 Series RAM Time Programmers are the most cost-effective way of dealing with the problem. They are flexible, easy to use, and provide 32 events (expandable to 96) in 5 1/4 inches of rack space.

780 Series units operate from the power line, with a backup crystal time base and 72 hour battery/charger as an integral part of the equipment.

- The front panel consists of:
  - An eight digit real time display when day selection is required as on the ES 781, 784, 785, seven digits for ES 780, and six digits for the others.
  - A two digit display of "Next Event" number when ES 780, 781, or 782 is specified, and a six digit display when ES 783, 784, 785, 786 or 787 is specified, and a four digit display when ES 788 or 789 is specified.
  - All displays are 3 inch red light emitting diodes.
  - Controls, mounted below the displays, consisting of:
    - An "Active-Disable" switch used when it is necessary to preempt the program temporarily.
    - Time Setting Controls—All recessed to avoid accidental bumping.
    - "Display"—The displays can be observed by actuating this control during a power outage. The unit will continue to operate, but the displays will be blanked to conserve battery energy.
    - "Event Select"—A two decade thumbwheel, used to set the event number when entering or reading data in the memory.
    - "Event Time Select"—An eight or six or four decade thumbwheel, used to enter the event time in the memory. The number of thumbwheels will be determined by the part number of the unit specified.
    - "Enter"—This pushbutton is actuated to enter data into the memory.
    - "Run-Read/Enter"—A two position switch, placed in the "Run" position for normal operation, and in the "Read/Enter" position whenever entering data or reading data.

### STANDARD UNITS

EIGHT DIGITS OF PROGRAMMING CAPABILITY

ES 780—10 Days, 10 Outputs, Hours, Minutes, Seconds

ES 781—100 Days, Hours, Minutes, Seconds

ES 782—16 Outputs, Hours, Minutes, Seconds

SIX DIGITS OF PROGRAMMING CAPABILITY

ES 783—Hours, Minutes, Seconds

ES 784—100 Days, Hours, Minutes

ES 785—100 Days, Minutes, Seconds

ES 786—16 Outputs, Hours, Minutes

ES 787—16 Outputs, Minutes, Seconds

FOUR DIGITS OF PROGRAMMING CAPABILITY

ES 788—Hours, Minutes

ES 789—Minutes, Seconds

The size of the unit is 5 1/4" High x 19" Wide x 10" Deep—Relay Rack construction, totally enclosed, with a screen top.

ES 782, 786 and 787 have 16 isolated outputs. Any of the 32 events can be programmed to activate any of the 16 outputs. ES 780 has 10 outputs. The other units have a single output.

ES 784, 786 and 788 have a one minute contact closure. The others have a one second contact closure. Contacts are single pole, form A, read type, and have a one amp rating.

THE 780 SERIES AS A MASTER CLOCK  
By adding the ES 187 Serial Time Code Generator and using a more accurate crystal, the 780 Series Ram Time Programmers can serve the dual functions of Master Clock and 96 event programmable timer.



## 750 SERIES THUMBWHEEL PROGRAMMER/ COMPARATOR \$310 to \$390

When programming up to eight time events, the 750 Series is recommended. Thumbwheel switches are set to compare the time information from an ESE Clock or Timer.

An output (event) occurs each time the thumbwheel switch setting agrees with the time display.

One set of thumbwheels is required for each event. The standard 750 Series units are enclosed in a 3 1/2 inch high relay rack panel, and chassis.

### STANDARD UNITS

ES 750—ES 112 and one 6 Digit Program

ES 751—ES 124 and one 6 Digit Program

ES 753—ES 112 and two 4 Digit Programs (Hrs & Min)

ES 754—ES 124 and two 4 Digit Programs (Hrs & Min)

ES 756—ES 510 and one 4 Digit Program (Min & Sec)

ES 758—ES 510 and two 4 Digit Programs (Min & Sec)

## ES 760 \$620

### ATS CLOCK

The ES 760 is a six digit, 24 hour, programmable clock.

On the front panel are a six digit display of time, in hours, minutes and seconds, and two sets of four thumbwheels.

An internal comparator is fed "Clock Time" and "Thumbwheel Time," and when these two agree, a reed relay contact closure occurs, which is brought to a rear-mounted connector. The connector also provides four line parallel BCD time information.

If normal power is interrupted, ES 760 will automatically switch to its internal battery and crystal time base.

Mechanical: 3 1/2" High x 19" Wide x 8" Deep

## PRESETTABLE TAPE TIMERS

## ES 1296 \$195.00

For Off-Air taping, or operating tape recorders when nobody is there. ESE has created ES 1296.

ES 1296 is a six digit, twelve hour clock with LED displays and a programmable, 300 watt, 117V AC outlet on the rear.

There are four push-button controls (Fast, Slow, Set and Reset) and a four position selector switch. The Fast and Slow controls are used to set time of day and recorder start time.

When setting the recorder start time, the Set control is used in addition to the Fast and Slow controls, to set the time to the nearest minute. A rear-mounted four position switch is used to pre-set the start time as far ahead as 96 hours.

Once the rear outlet is activated, it will remain on for 66 minutes.

The Record Duration option allows the user to select one of four time intervals for recording. These four time intervals are: other 16, 33, 66 and 138 minutes, or 33, 66, 138 and 250 minutes.

An additional option is Sequential Turn-on, for those machines that require Power, Play, Record in sequence.

A Manual Override Switch can be provided as an option, so that the user may operate his machine at any time without disconnecting from the ES 1296.

# PERFECT TIMING

## MASTER CLOCKS

ES 160 Mounted in a 5 1/4" relay rack panel and chassis, displays six digits of time information on 3" LED displays, in 12 hour format.

ES 160 has three second per month accuracy. Its standard output is serial BCD, CMOS compatible, and can drive ES 161, 166, 171, 991 or 993 Remote Displays without buffering. All inputs and outputs are through rear-mounted connectors.

Dimensions: 5 1/4" High x 19" Wide x 15" Deep \$1050.00

ES 160/1 One second per month version of ES 160 \$1225.00

ES 190 The ultimate in accuracy! Similar to ES 160, with special circuits for receiving and decoding a 1000 Hz tone at the start of each minute. The decoder output resets the seconds' counters in the clock each minute except the first minute of every hour. These tones are transmitted by radio station WWV, with an oscillator accuracy of  $\pm 1$  part in  $10^{10}$ . ES 190 has an antenna and internal WWV receiver with audio-output. Displays are 3" red LED's. Serial output drives ES 161, 166, 171, 991 and 993 Remote Displays.

Dimensions: 5 1/4" High x 19" Wide x 15" Deep \$1225.00

ES 192/194 The most economical Masters, ES 192 (12 Hr) and ES 194 (24 Hr) are constructed using ES 112 or ES 124 digital clocks and adding the ES 167 Serial Time Code Generator to provide the output needed to drive Remote Serial Displays ES 161, 166, 171, 991 and 993. Displays are 6" incandescent type.

Dimensions: 2 1/2" High x 8" Wide x 6" Deep \$325.00

ES 196 TIME AND TEMPERATURE MASTER Basically the same as ES 192, but with gas discharge displays, panel mounting and separate serial BCD outputs for time and temperature. Displays 12 hour and °F format.

Dimensions: 3 1/2" High x 19" Wide x 8" Deep \$766.00

### ACCESSORIES

ES 161 REMOTE DIGITAL DISPLAY Decodes serial time data and displays six digits of time on 55" Gas Discharge Displays in either 12 or 24 hour format.

Dimensions: 8" Wide x 2 1/2" High x 6" Deep \$165.00

ES 162 IMPULSE DRIVER Plugs into the ES 160 chassis, can drive 20 Impulse Clocks. Designed so that, if power fails, impulse always comes on with the same polarity when power is restored. \$200.00

ES 164 REMOTE DIGITAL IMPULSE DISPLAY Similar to the ES 161 except that the ES 164 derives its count command from the ES 162 Impulse Driver, or any impulse clock drive circuits already installed.

Dimensions: 8" Wide x 2 1/2" High x 6" Deep \$244.00

ES 166 JUMBO 1" CLOCK DISPLAY Features six digits of one inch gas discharge displays in 12 or 24 hour format. Receives serial time code input from any ESE Master Clock or ES 167.

Dimensions: 10 1/2" Wide x 4 1/2" High x 6 1/2" Deep \$254.00

ES 167 SERIAL TIME CODE GENERATOR An integral part of ES 160, 190, 192/194 and 196 Master Clocks, this unit can be added to many other ESE products, including ES 112, 124, 182, 184, 992, 994, 750, 751, 753, 754 and all 780 Series Time Programmers. Drives ES 161, 166, 171, 991 or 993 Remote Displays. \$146.00

ES 169 TEMPERATURE SLAVE Receives serial code from ES 196, displays it on 55" Gas Discharge Displays.

Dimensions: 8" Wide x 2 1/2" High x 6" Deep \$146.00

ES 171 CONSOLE MOUNT REMOTE DISPLAY Receives the serial time code generated by any ESE Master Clock, or any ESE product containing the ES 167 serial time code generator, and displays it on bright red, 3" LED's.

Dimensions: 2 1/2" High x 4 1/2" Wide x 4" Deep \$158.00

ES 1548 CONSOLE MOUNT TEMPERATURE DISPLAY in the same case as ES 171, receives the serial code from ES 196 and displays it on bright red, 3" LED's.

Dimensions: 2 1/2" High x 4 1/2" Wide x 4" Deep \$158.00

IMPULSE CLOCK When a sweep second hand is desired, specify the 3201 003 "Extra Flat" Impulse Clock. It has a 12 inch dial protected by a glass cover and metal bezel and is approximately one inch thick. As many as twenty impulse clocks can be driven by a Master Clock which has ES 162 as an accessory. \$200.00

ES 991 4 DIGIT SERIAL INPUT SLAVE Decodes serial time data and displays four digits of time on large 2" gas discharge displays.

Dimensions: 10 1/2" Wide x 4 1/2" High x 6 1/2" Deep, Desk Top Case \$325.00

ES 993 6 DIGIT SERIAL INPUT SLAVE Features four digits of 2" high gas discharge displays, and two digits (Seconds) of 1" gas discharge displays. Receives serial time code input from any ESE Master Clock or ES 167.

Dimensions: 5" High x 12" Wide x 3" Deep (Wall Mount) \$449.00

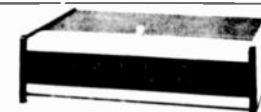

## ES 251 \$295.00

ES 251 SMPTE TIME CODE READER: ES 251 is a six digit SMPTE Time Code Reader displaying Hours, Minutes and Seconds. Receives the standard SMPTE Time Code through rear mounted BNC connector, converts it into six digits of clock time.

Dimensions: Aluminum Case 2 1/2" High x 8" Wide x 5 1/2" Deep

ES 252 SMPTE TIME CODE READER: Exactly like ES 251, but displays Minutes, Seconds and Frames.

ES 253 SMPTE TIME CODE READER: Similar to ES 251 and 252, but displaying EIGHT DIGITS of information—HOURS, MINUTES, SECONDS and FRAMES, using 3" red LED's.

ES 254 SMPTE TIME CODE READER: is a bi-directional, multi-speed eight digit reader, displaying Hours, Minutes, Seconds and Frames on .3" red LED displays. \$850



## ES 1372 \$280.00

The ES 1372 is similar to the ES 1296, except that ES 1372 has two timed AC outlets. AC power is applied to outlet "1" at the alarm time and day selected and remains on for 138 minutes and 53 seconds. AC power is applied to outlet "2" 60 minutes after power has been applied to outlet "1" and remains on for 78 minutes and 53 seconds. All other specifications of the ES 1296 apply.

## ES 112/124

DIGITAL CLOCK \$165.00

ES 112 (12 hr.) and ES 124 (24 hr.) are solid state, six digit clocks. Can drive 80 Series and 90 Series slaves. Displays are incandescent filament 6" high.  
Dimensions: 2 1/2" High x 8" Wide x 6" Deep



## ES 142/144

DIGITAL CLOCK THERMOMETER \$300.00

ES 142 (12 hr.) and ES 144 (24 hr.) are solid state digital clock/thermometers. Six digits of time (hours, minutes, seconds) and 3 digits of temperature (-50°F to +150°F or -45°C to +66°C) in gas discharge displays. 55" high. Temperature sensor on 25 ft. cable included.  
Dimensions: 2 1/2" High x 10" Wide x 6" Deep

## ES 240/241

ES 240 DIGITAL THERMOMETER is calibrated for °F and °C. Displays are planar gas discharge. 55" high. \$195.00  
Dimensions: 2 1/2" High x 8" Wide x 6" Deep

ES 241 DIGITAL THERMOMETER is calibrated for °F and °C, alternating between the two every four seconds. Displays are planar gas discharge. 55" high. \$236.00

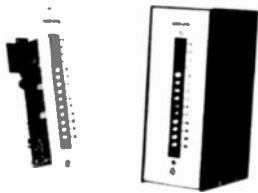

## ES 211/214

DYNAMIC AUDIO LEVEL INDICATOR

The ES 214 is a highly accurate audio level indicator which is designed to simulate the action of a conventional VU-Meter but with superior dynamic characteristics. The LED meter is five to one hundred times faster in responding to complex waveforms than the mechanical meter without sacrificing the familiar meter movement. \$135.00 \$113.00

### SPECIFICATIONS

Number of Indicators: 14 LED Lamps in 3 colors

Scale: +4, +3, +2, +1 dB—Red  
0 dB—Yellow  
-1, -2, -3, -5, -7, -10,  
-15, -20, -25 dB—Green

Input Impedance: 2200 ohms at maximum sensitivity, 6800 ohms at +8dBm. House Level: 10,000 ohms at minimum sensitivity.  
Input Circuit: Transformer isolated, balanced bridging.  
Frequency Response: 20-20 KHz ± 1 dB (all modes)

Rise Time: Less than 250 MicroSec (Peak Mode) less than 25 MilliSec (Fast Averaging Mode). Approximately 300 MilliSec (Optional VU Standard).  
Fall Time: (All Modes) About 300 MicroSec from full scale.

Modes of Operation: Peak Reading, Fast Averaging (Apparent Loudness), Slow Averaging (USA VU-Standard)



## 70 SERIES

CONSOLE MOUNT CLOCKS AND TIMERS

ES 172 SIX DIGIT, 12 HOUR CLOCK; Three setting controls—Fast Advance, Slow Advance and Hold \$158.00

ES 174 SIX DIGIT, 24 HOUR CLOCK; Otherwise identical to the ES 172 \$158.00

ES 370 FOUR DIGIT, ONE HUNDRED MINUTE UP/DOWN TIMER; Six controls—Count Up, Count Down, Stop, Minutes Advance, Seconds Advance, Reset \$201.00

ES 371 UP/DOWN TIMER; Similar to the ES 370 except with Leverwheel Preset capability for faster setting of the desired time \$319.00

ES 570 FOUR DIGIT, SIXTY OR 100 MINUTE TIMER; Select 60 or 100 minute mode on rear connector. Start, Stop and Reset controls. Runs continuously unless stopped. Reset will return all displays to zero. Unit will run if reset while running or will stay at zero if reset when stopped \$158.00

ES 572 SIX DIGIT, 12 HOUR CLOCK OR TIMER; Five controls—Start Stop Reset Fast Advance Slow Advance. Run continuously to 12:59:59. Advances to 1:00:00 and continues as clock unless stopped or advanced \$192.00

ES 574: A 24 hour version of ES 572 \$192.00

ES 575: Exactly like ES 570 with the addition of a 'freeze' button. When the button is released, the display catches up with the correct elapsed time \$192.00

Dimensions: 2 1/2" High x 4 1/2" Wide x 4 1/2" Deep

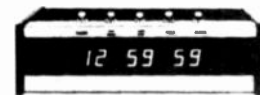

## ES 562/564

SIX DIGIT CLOCK/TIMER WITH MEMORY \$313.00

ES 562/564 is a combination six digit clock and 24 hour timer with memory, allowing the user to set the clock to the correct time of day, switch to timer mode, then switch back to time of day by pushing one button. Time of day will be correctly displayed, in hours, minutes and seconds. Five pushbutton controls are mounted on the top of the unit. Near the front of the desk-top case. When panel mounting is specified, they will be mounted on the front panel; below the display. The controls may also be removed through two rear-mounted five pin connectors (Option R or Option D). These controls are Clock, Fast/Start, Slow/Stop, Timer and Hold.  
Display: Six digits of 55" Planar Gas Discharge Display



## ES 280 \$500

AUDIO TIME CODE GENERATOR/READER

The ES 280 is a 10 Digit Audio Time Code Generator/Reader, capable of laying down a serial BCD time code on audio tape in the Generator Mode, and recovering and displaying it in Digital form in the Reader Mode. The code has been designed by ESE. It is not a standard code, such as SMPTE or IRIG. The frequencies used to produce the code have been selected to be compatible with cartridge machines as well as other tape recording and playback equipment. Amplitude adjustment assures the right amount of signal for the particular machine being used.

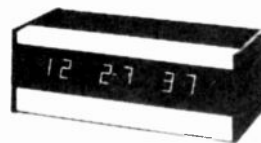

## 80 SERIES

JUMBO CLOCKS AND TIMERS

Large bright 1" gas discharge displays provide effortless long distance viewing from 40 feet

ES 182 SIX DIGIT, 12 HOUR CLOCK; Three rear-mounted setting controls—Fast Advance, Slow Advance and Hold \$272.00

ES 184 SIX DIGIT, 24 HOUR CLOCK; Otherwise identical to the ES 182 \$272.00

ES 380 FOUR DIGIT, 100 MINUTE UP/DOWN TIMER; Displays minutes and seconds with rear-mounted connector to allow remote wiring of six momentary SPST CONTROLS—Count Up, Count Down, Stop, Minutes Advance, Seconds Advance and Reset. Other features similar to ES 301 \$316.00

ES 381 UP/DOWN TIMER; Similar to ES 380 except that leverwheel preset is used \$416.00

ES 580 FOUR DIGIT, 60 MINUTE TIMER; Displays minutes and seconds. Rear connector allows remote wiring of three momentary SPST controls—Start, Stop and Reset. Reset returns all displays to zero and timer will continue to run from zero if reset while running.

80 Series slaves are also compatible with other ESE clocks and timers ES 112/124, 301, 302 and 510. \$228.00  
Dimensions: 4 1/2" High x 10 3/8" Wide x 6 5/8" Deep

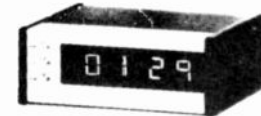

## ES 510L

FOUR DIGIT 60 MINUTE TIMER \$158.00

ES 510 is a four digit sixty minute timer (59:59) with Start Stop and Reset controls. If stopped, display will hold time reading and when restarted will continue with next count from last displayed figure. If reset while running, timer will continue to run. ES 510 can drive 80 Series and 90 Series Slaves.  
Dimensions: 2 1/2" High x 6" Wide x 6" Deep



## ES 203/205 \$89.00

ES 203/205 is a 20 input Timer/Source Interface. It was designed to provide a simple means of connecting a variety of sources such as carts and turntables to the remote input of ESE Timers. The most common application for this product is resetting either an ES 400 or ES 510 Timer each time a source is started.

The 20 inputs are divided into ten DC voltage inputs and ten contact closure inputs. Activation of any one of these inputs will cause an output which will momentarily reset an ESE timer.

Mechanical: Aluminum Case 8" x 6" x 2"



## 90 SERIES

2 INCH DISPLAYS—VIEWABLE AT 60 FEET

ES 301—Presettable Up/Down Timer; 100 Minute Range—Displays Minutes and Seconds, uses Leverwheel Preset Controls are Count Up, Count Down, Stop, Reset and Preset \$487.00  
Dimensions: 4 1/2" High x 10 3/8" Wide x 6 5/8" Deep

ES 990—Sixty Minute Timer; Displays Minutes and Seconds. Rear-mounted connector provides for wiring to user's single pole, momentary push-button controls. Start Stop and Reset. Reset returns all displays to zero and timer will continue to run from zero if reset while counting \$341.00  
Dimensions: 4 1/2" High x 10 3/8" Wide x 6 5/8" Deep

ES 992/994—8 Digit Clocks; ES 992 (12 Hr) and ES 994 (24 Hr)—Hours and Minutes on Two Inch Gas Discharge Displays, Seconds on One Inch Gas Discharge Displays. Three top-mounted setting controls—Fast Advance, Slow Advance and Hold \$449.00

Dimensions: 5" High x 12" Wide x 3 1/2" Deep



## ES 301/302

100 MINUTE UP/DOWN TIMERS

\$234.00 \$302.00

ES 301 is a four digit one hundred minute timer (99:59) with six controls: Count Up, Count Down, Stop, Minutes Advance, Seconds Advance. Reset Counting can be activated up or down or set back to zero. When 'Stop' control is pressed the four digit display is held. Counting direction (up or down) can be changed or time can be reset to zero without stopping the count. The ES 301 can drive 80 Series and 90 Series Slaves. Displays are gas discharge. 55" high.



With the ES 302, the user can preset times much faster than with the ES 301, because lever-wheel type switches are used for the preset feature. The ES 302 can drive 80 Series and 90 Series Slaves.  
Dimensions: ES 301: 2 1/2" High x 8" Wide x 6" Deep  
ES 302: 2 1/2" High x 10" Wide x 6" Deep



## ES 206

VIDEO TIME AND DATE GENERATOR \$475.00

The ES 206 has been designed to allow the addition of Time and Date information to a video signal. Two rear-mounted video jacks permit looping the video information through the 206 to add the data.

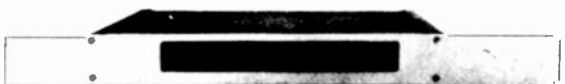

## ES 270 IRIG B TIME CODE READER \$350

The ES 270 TIME CODE READER has been designed to be an economical solution to the problem of receiving and displaying IRIG B.

Nine digits (Days, Hrs, Min, Sec) of time are shown on bright red LED's, 3" character height. ES 270 comes in a rack mounting enclosure, 1 1/2" High, 19" Wide and 10" Deep. The power requirement is 117V AC, 50/60 Hz, 230V AC, 50 Hz is available as an option.





**Electro-Voice®**

## PROFESSIONAL MICROPHONES

**RE20**  
**Variable-D®**  
**Dynamic Cardioid**

The RE20 was created especially for critical recording, broadcast, and sound reinforcement applications which require response that extends to the frequency extremes. Combined with a subtle elevation of response in the 5,000 to 15,000 Hz range, the RE20 provides performance heretofore available only from the most expensive condenser microphones. **\$445.00**

**Frequency Response:** 45-18,000 Hz  
**Impedance:** 150 ohms (changeable to 50 or 250 ohms)  
**Output:** 57 dB  
**Diaphragm:** EV Acoustalloy™  
**Case:** Steel  
**Finish:** Fawn beige micomatte  
**Size:**  
216.7mm (8<sup>11</sup>/<sub>32</sub>) long  
54.4mm (2<sup>1</sup>/<sub>4</sub>) max diameter  
49.2mm (1<sup>15</sup>/<sub>16</sub>) body diameter  
**Weight:** 737 grams (1 lb, 10 oz)  
**Cable:** 4.6m (15') Switchcraft A3F conn  
**Included:** Stand adapter, metal carrying case



**RE18**  
**Shock-Mounted**  
**Variable-D®**  
**Dynamic Cardioid**

The RE18 is a direct descendant of the popular RE15 and RE16 microphones. While maintaining the accurate frequency response characteristics and super-cardioid polar pattern of the RE15, the RE18 has added an integral shock mount for even better performance. **\$279.25**

**Frequency Response:** 80-15,000 Hz  
**Impedance:** 150 ohms  
**Output:** 57 dB  
**Diaphragm:** EV Acoustalloy™  
**Case:** Steel  
**Finish:** Silver tone beige  
**Size:**  
178mm (7") long  
41mm (1<sup>7</sup>/<sub>8</sub>) max diameter  
19mm (3/4") shank diameter  
**Weight:** 230 grams (8 oz)  
**Cable:** 4.6m (15') Switchcraft A3F conn  
**Included:** 312B stand adapter, protective vinyl carrying pouch



**RE15**  
**Variable-D®**  
**Dynamic Super-Cardioid**

Literally born in a Hollywood TV studio, the performance and reliability of the RE15 have made it the workhorse directional microphone for broadcast and high-quality sound reinforcement. **\$256.75**

**Frequency Response:** 80-15,000 Hz  
**Impedance:** 150 ohms  
**Output:** 56 dB  
**Diaphragm:** EV Acoustalloy™  
**Case:** Steel  
**Finish:** Fawn beige micomatte  
**Size:**  
167mm (6<sup>9</sup>/<sub>16</sub>) long  
35mm (1<sup>3</sup>/<sub>8</sub>) diameter  
19mm (3/4") shank diameter  
**Weight:** 170 grams (6 oz)  
**Cable:** 4.6m (15') Switchcraft A3F conn  
**Included:** 310A clamp, metal carrying case

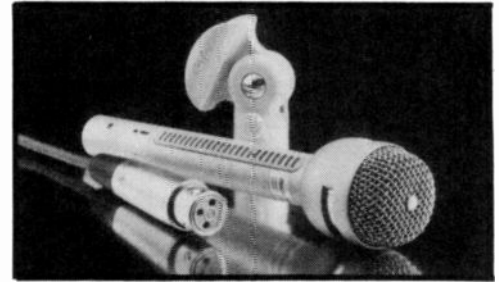

**RE16**  
**Variable-D®**  
**Dynamic Super-Cardioid**

Another professional favorite, the RE16 is like the RE15 except it has a different blast filter. An integral part of the RE16, the blast filter makes possible the closest hand-held use without any "P-pops." In all other respects, the RE16 is like the RE15. Its rugged, mechanically "nested" design is highly resistant to damage. **\$269.50**

**Frequency Response:** 80-15,000 Hz  
**Impedance:** 150 ohms  
**Output:** 56 dB  
**Hum Pickup Level:**  
-125dBm (re 001 gauss field)  
**Diaphragm:** EV Acoustalloy™  
**Case:** Steel  
**Finish:** Fawn beige micomatte  
**Size:**  
187mm (7<sup>3</sup>/<sub>8</sub>) long  
45mm (1<sup>7</sup>/<sub>8</sub>) max diameter  
19mm (3/4") shank diameter  
**Weight:** 227 grams (8 oz)  
**Cable:** 4.6m (15') Switchcraft A3F conn  
**Included:** 310A clamp, metal carrying case



**RE10**  
**Variable-D®**  
**Dynamic Super-Cardioid**

A fine, moderate-cost microphone for sound reinforcement, broadcasting, choir pickup and stage work. The RE10 is similar in design to the RE15, but meets requirements where somewhat more unit-to-unit variability is acceptable. **\$166.50**

**Frequency Response:** 90-13,000 Hz  
**Impedance:** 150 ohms  
**Output:** 56 dB  
**Diaphragm:** EV Acoustalloy™  
**Case:** Steel  
**Finish:** Fawn beige micomatte  
**Size:**  
172mm (6<sup>3</sup>/<sub>4</sub>) long  
35mm (1<sup>3</sup>/<sub>8</sub>) max diameter  
19mm (3/4") shank diameter  
**Weight:** 170 grams (6 oz)  
**Cable:** 4.6m (15') Switchcraft A3F conn  
**Included:** 310A clamp, metal carrying case



**RE11**  
**Variable-D®**  
**Dynamic Super-Cardioid**

An excellent microphone for broadcast and quality sound reinforcement, the RE11 is a modestly priced unit with many of the features of the RE16 but where the most precise unit-to-unit matching is not necessary. **\$179.50**

**Frequency Response:** 90-13,000 Hz  
**Impedance:** 150 ohms  
**Output:** 56 dB  
**Diaphragm:** EV Acoustalloy™  
**Case:** Steel  
**Finish:** Fawn beige micomatte  
**Size:**  
187mm (7<sup>3</sup>/<sub>8</sub>) long  
45mm (1<sup>7</sup>/<sub>8</sub>) max diameter  
19mm (3/4") shank diameter  
**Weight:** 227 grams (8 oz)  
**Cable:** 4.6m (15') Switchcraft A3F conn  
**Included:** 310A clamp, metal carrying case







**Electro-Voice®**

## PROFESSIONAL MICROPHONES

### CS15P Phantom Powered Single-D Condenser Cardioid

The CS15P is a high-performance microphone for those recording, broadcast and sound reinforcement applications that demand a directional polar pattern as well as the wideband frequency response usually avoided in "general use" professional microphones. The distant response of the CS15P has been subtly shaped in a way that has been shown useful in the recording studio. **\$263.00**

**Frequency Response:** 40-18,000 Hz  
**Impedance:** 150 ohms  
**Output:** 45 dB  
**Element:** Condenser (e-ectret)  
**Maximum SPL for 1% THD:** 141 dB at 1000 Hz load - 1200 ohms  
**Equivalent Noise Level:** Less than 22 dB SPL A weighted  
**Power:** Phantom (8-50V)  
**Case:** Steel  
**Finish:** Fawn beige micomatte  
**Cable:** 4.6m (15') Switchcraft A3F conn  
**Included:** 315A windscreen 312A clamp metal carrying case

**Size:**  
176mm (6<sup>9</sup>/<sub>16</sub>") long  
27mm (1<sup>1</sup>/<sub>8</sub>") max diameter  
19mm (3<sup>4</sup>/<sub>8</sub>") shank diameter  
**Weight:** 227 grams (8 oz)

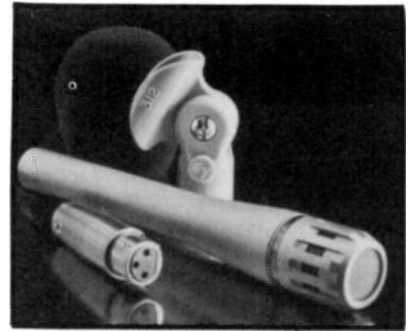

### DS35 Single-D Dynamic Cardioid

Created especially for the professional entertainer, the DS35 has become a connoisseur's microphone. Its Single-D design emphasizes the low frequencies in up-close, hand-held applications. **\$150.00**

**Frequency Response:** 60-17,000 Hz  
**Impedance:** 150 ohms  
**Output:** 60 dB  
**Diaphragm:** EV Accustalloy polystyrene Volumetric Dome  
**Case:** Steel  
**Finish:** Fawn beige micomatte  
**Cable:** 4.6m (15') Switchcraft A3F conn  
**Included:** 312A clamp metal carrying case

**Size:**  
184mm (7<sup>1</sup>/<sub>4</sub>") long  
48mm (1<sup>7</sup>/<sub>8</sub>") max diameter  
19mm (3<sup>4</sup>/<sub>8</sub>") shank diameter  
**Weight:** 261 grams (9.2 oz)



### CO15P Phantom Powered Condenser Omnidirectional

The CO15P is the finest omnidirectional microphone we manufacture. Its element is used in precision real-time acoustic analyzers. Response extends from below 20 to 20,000 Hz. Unlike typical "omnidirectional" microphones, the CO15P maintains true omnidirectional performance at the highest frequencies. **\$283.25**

**Frequency Response:** 20-20,000 Hz  
**Impedance:** 150 ohms  
**Output:** 45 dB  
**Element:** Condenser (electret)  
**Maximum SPL for 1% THD:** 145 dB at 1000 Hz load - 1200 ohms  
**Equivalent Noise Level:** Less than 26 dB SPL A weighted  
**Power:** Phantom (9-50V)  
**Case:** Steel  
**Finish:** Fawn gray miccomatte  
**Cable:** 4.6m (15') Switchcraft A3F conn  
**Included:** 315A windscreen 310A clamp metal carrying case

**Size:**  
173mm (6<sup>7</sup>/<sub>8</sub>") long  
27mm (1") max diameter  
19mm (3<sup>4</sup>/<sub>8</sub>") shank diameter  
**Weight:** 213 grams (7.5 oz)



### RE55 Dynamic Omnidirectional

The RE55 has the widest frequency response of all E-V dynamic microphones, 40-20,000 Hz. A classic design, the RE55's heritage goes back over twenty-five years to the original 655 which changed the broadcast industry's idea of what a dynamic microphone could do. **\$259.00**

**Frequency Response:** 40-20,000 Hz  
**Impedance:** 150 ohms  
**Output:** 57 dB  
**Diaphragm:** EV Acoustalloy  
**Case:** Steel  
**Finish:** Fawn beige micomatte  
**Cable:** 4.6m (15') Switchcraft A3F conn  
**Included:** 310A clamp metal carrying case

**Size:**  
266.7mm (10<sup>1</sup>/<sub>2</sub>") long  
30.9mm (1<sup>1</sup>/<sub>8</sub>") max diameter  
19mm (3<sup>4</sup>/<sub>8</sub>") shank diameter  
**Weight:** 241 grams (8<sup>1</sup>/<sub>2</sub> oz)

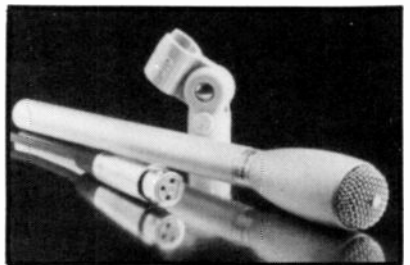

### DO54 Dynamic Omnidirectional

Based on the RE55, the DO54 is a moderately priced microphone with essentially flat response over its rated frequency range of 50-18,000 Hz. It is useful in applications where the RE55 would excel but where the one-third-octave additional response below 50 Hz is not required, or where small microphone-to-microphone variation is acceptable. **\$146.00**

**Frequency Response:** 50-18,000 Hz  
**Impedance:** 150 ohms  
**Output:** 58 dB  
**Diaphragm:** EV Acoustalloy  
**Case:** Steel  
**Finish:** Fawn beige micomatte  
**Cable:** 4.6m (15') Switchcraft A3F conn  
**Included:** 310A clamp metal carrying case

**Size:**  
146mm (5<sup>3</sup>/<sub>4</sub>") long  
29mm (1<sup>1</sup>/<sub>8</sub>") max diameter  
19mm (3<sup>4</sup>/<sub>8</sub>") shank diameter  
**Weight:** 184 grams (6.5 oz)

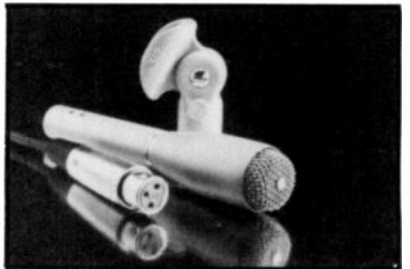

### DO56 Shock-Mounted Dynamic Omnidirectional

The DO56 is a shock-mounted omnidirectional microphone for hand-held broadcast and sound reinforcement applications. All handling noises and cord vibration are isolated from the microphone element. **\$125.00**

**Frequency Response:** 80-18,000 Hz  
**Impedance:** 150 ohms  
**Output:** 61 dB  
**Diaphragm:** EV Acoustalloy  
**Case:** Steel and aluminum  
**Finish:** Silver tone beige  
**Cable:** 4.6m (15') Switchcraft A3F conn  
**Included:** 312B stand adapter, protective vinyl carrying pouch

**Size:**  
159mm (6<sup>1</sup>/<sub>4</sub>") long  
37mm (1<sup>5</sup>/<sub>16</sub>") max diameter  
19mm (3<sup>4</sup>/<sub>8</sub>") shank diameter  
**Weight:** 185 grams (6.5 oz)



### DO56L (Long Case)

**\$141.00**

Prices and Specifications Subject to Change Without Notice.



**Electro-Voice®**

## PROFESSIONAL MICROPHONES

### **RE50** **Shockproof** **Dynamic Omnidirectional**

The RE50 was designed expressly for hand-held news-gathering work. It has the same tailored frequency response and high output level as the famous 635A. **\$146.50**

**Frequency Response:** 80-13,000 Hz  
**Impedance:** 150 ohms  
**Output:** 55 dB  
**Diaphragm:** EV Acoustalloy\*  
**Case:** Aluminum  
**Finish:** Fawn beige micomatte  
**Size:**  
197mm (7<sup>3</sup>/<sub>4</sub>) long  
49mm (1<sup>5</sup>/<sub>16</sub>) max diameter  
25mm (1) shank diameter  
**Weight:** 269 grams (9<sup>1</sup>/<sub>2</sub> oz)  
**Cable:** 4.6m (15) Switchcraft A3F conn  
**Included:** 301A clamp, metal carrying case



### **635A** **Dynamic Omnidirectional**

The 635A is quite simply the most rugged, durable microphone we manufacture. The 635A's moderately high output level (-55 dB) is appropriate for a broad range of studio and field applications. Its response has been specially shaped for up-close vocals. **\$92.00**

**Frequency Response:** 80-13,000 Hz  
**Impedance:** 150 ohms  
**Output:** 55 dB  
**Diaphragm:** EV Acoustalloy\*  
**Case:** Steel  
**Finish:** Fawn beige micomatte  
**Size:**  
151mm (5<sup>15</sup>/<sub>16</sub>) long  
36mm (1<sup>13</sup>/<sub>32</sub>) diameter  
**Weight:** 170 grams (6 oz)  
**Cable:** 4.6m (15) Switchcraft A3F conn  
**Included:** 312A clamp

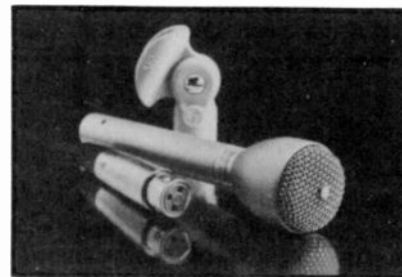

### **CL42S** **Cardiline® Condenser** **Unidirectional**

The most directional shotgun microphone for its size ever made, the CL42S for the first time combines the best qualities of line and hyper-cardioid patterns. The CL42S reaches farther and rejects more ambient noise than other "shotguns," condenser or dynamic. The CL42S features an exclusive line-bypass port which produces the low frequency response ideal for boom use while maintaining a hyper-cardioid polar response at low frequencies. Unlike other shotguns which get very narrow at high frequencies, the CL42S retains its high frequency directivity through a series of diffraction vanes on the line tube. **\$660.00**

**Frequency Response:** 90-12,000 Hz  
**Impedance:** 150 ohms  
**Output:** 45 dB  
**Element:** Condenser (electret)  
**Maximum SPL for 1% THD:** 129 dB at 1000 Hz load 1200 ohms  
**Equivalent Noise Level:** Less than 14 dB SPL A weighted  
**Power:** A-B (10-16V) phantom (9-50V)  
**Case:** Steel & aluminum  
**Finish:** Fawn beige micomatte  
**Size:**  
416mm (16 4) long  
26.8mm (1.06) largest diameter  
**Weight:** 578 grams (20.4 oz) complete  
263 grams (9.3 oz) mike only  
**Cable:** Special coiled cord from mic to bail for mechanical isolation  
**Included:** Windscreen, shock mount, screw-on handle, carrying case

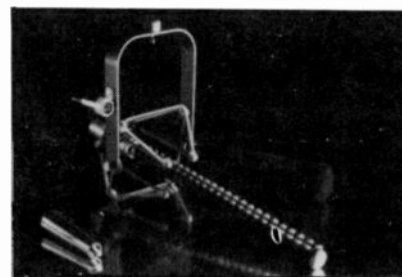

### **DL42** **Cardiline®** **Dynamic Unidirectional**

The DL42 is state-of-the-art in super-directional dynamics. "Cardiline" is E-V's patented combination of line and cardioid design. Compared to other "shotguns," the DL42 has more uniform response in the critical mid and high frequencies and much more uniform directivity. **\$494.00**

**Frequency Response:** 50-12,000 Hz  
**Impedance:** 150 ohms  
**Output:** 50 dB  
**Diaphragm:** EV Acoustalloy  
**Case:** Aluminum & steel  
**Finish:** Fawn beige micomatte  
**Size:**  
425mm (16<sup>1</sup>/<sub>4</sub>) long  
95mm (3<sup>1</sup>/<sub>4</sub>) max diameter  
**Weight:** 800 grams (1.1 lb 11 oz) complete  
369 grams (13 oz) mike only  
**Cable:** Special coil cord to extend from mike connector (Switchcraft A3M) to shock mount bail for mechanical isolation  
**Included:** Screw-on handle, windscreen, shock mount and carrying case

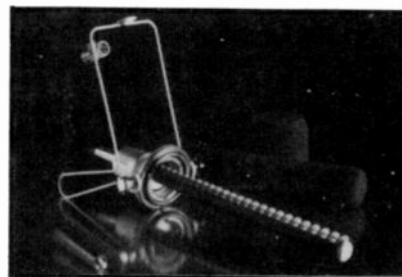

### **CH15S** **Condenser Single-D Hyper-cardioid**

The unique CH15S was developed particularly for boom and fishpole use in TV and motion picture studios where the need is great for light weight, small size and high directionality. The complete microphone and shock-mount system weighs just over 10 ounces. **\$507.80**

**Frequency Response:** 55-13,500 Hz  
**Impedance:** 150 ohms  
**Output:** 40 dB  
**Element:** Condenser (electret)  
**Maximum SPL for 1% THD:** 136 dB at 1000 Hz load 1200 ohms  
**Equivalent Noise Level:** Less than 16 dB SPL A weighted  
**Power:** A-B (10-16V) phantom (9-50V)  
**Case:** Steel & aluminum  
**Finish:** Fawn beige micomatte  
**Size:**  
(with shock mount)  
99mm (3.9) long  
89mm (3.5) wide  
76mm (3) high  
**Weight:** 292 grams (10.3 oz) complete  
161 grams (5.7 oz) mike only  
**Included:** Integral coiled cable, shock mount, windscreen, flex relief insert, metal carrying case





**Electro-Voice®**

## PROFESSIONAL MICROPHONES

### CO90 and CO90E

#### Miniature Condenser Omnidirectionals

Perfect for today's broadcasting and wide-range sound reinforcement systems. They are more reliable and more versatile than other condenser lavaliers. The two-conductor cable incorporates two nylon stay cords for high breaking strength. The cable-to-case interface is built to last. If there is an accident, the cable assembly is field replaceable.

The CO90 includes all components shown. The CO90E eliminates the battery/transformer housing, for direct interface with wireless transmitter, miniature recorder, etc. **CO90 \$145.00 CO90E 98.00**

Frequency Response: 40-15,000 Hz  
Impedance: 150 ohms  
Output: 57 dB  
Element: Condenser (electret)  
Operating Voltage: 1.1-1.8V Battery Mallory RM-625 or equivalent (not supplied)  
Battery Life: Over 1000 hours  
Case: Mike brass, electronics aluminum, battery transformer housing steel  
Finish: Fawn beige micomatte  
Mike Size: 21 mm ( 851 ) long,  
10.5 mm ( 415 ) max diameter  
Weight: 114 grams ( 4 oz ) complete, less battery, 23 grams ( 8 oz ) less battery transformer housing & belt clip  
Cable: Mike to battery housing, 1.83m ( 6 )  
Included: Tie clasp, 385 windscreen, protective pouch, belt clip

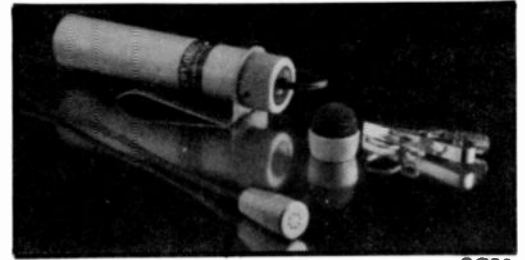

CO90

### CO90P

#### Miniature Condenser Omnidirectional

The CO90P is a phantom-powered version of the popular CO90, for no-battery-to-fail reliability. **\$176.50**

Frequency Response: 90-10,000 Hz  
Impedance: 150 ohms  
Output: 61 dB  
Diaphragm: EV Acoustalloy  
Case: Steel  
Finish: Champagne  
Size:  
67mm (2 5/8 ) long  
23mm ( 3/4 ) max diameter  
Weight: 229 grams ( 8 oz )  
Cable: 9.14m ( 30 )  
Included: Neck cord, tie clasp, cable belt clip, protective pouch



RE85

### CO94

#### High-Performance Miniature Condenser Omnidirectional

The CO94 does not have the limited dynamic range typical of miniature microphones powered by low-voltage batteries. A CO94 is typically 10 dB greater in sensitivity than conventional designs and will accept 20 dB greater input SPL before overload (141 dB). Thus, the CO94 may be used where other miniature microphones are simply unacceptable. A high-pass filter cuts off unwanted noise below 80 Hz. The CO94 may be phantom or battery powered, including a dual-power mode where a battery ensures against loss of signal should the phantom power fail. **\$225.00**

Frequency Response: 70-16,000 Hz  
Impedance: 150 ohms  
Output: 56 dB  
Element: Condenser (electret)  
Operating Voltage: 1.1-1.8V Battery Mallory RM-625 or equivalent (not supplied)  
Battery Life: Over 1000 hours  
Case: Steel & high-impact plastic  
Finish: Fawn beige micomatte  
Size:  
Mike 10.3mm ( 1 1/32 ) diameter  
6.4mm ( 1/4 ) deep electronics 38.1mm ( 1 1/2 ) long 13.5mm ( 1 1/2 ) wide 9.5mm ( 3/8 ) deep  
Weight: Mike 2.8 grams ( 1 oz )  
Electronics 7.1 gram ( 1/4 oz )  
Included: 385 windscreen, belt clip, tie clip adapter, metal carrying case



CO85A

### RE85

#### Shock-Mounted Miniature Dynamic Omnidirectional

Here's a lavalier microphone that offers professionals in the TV industry great protection from cord and case-conducted mechanical noise. The RE85 has an internally shock-mounted microphone capsule which is "floating" in high-compliance rubber inside the durable steel case. "Slippery" cable and case finishes reduce transmission of mechanical disturbances to the shock mount. Response is tailored for the lavalier chest position.

**\$139.75**

Frequency Response: 80-10,000 Hz  
Impedance: 150 ohms  
Output: 61 dB  
Diaphragm: EV Acoustalloy™  
Case: Aluminum  
Finish: Non-reflecting gray  
Size:  
57mm (2 1/4 ) long,  
19mm ( 3/4 ) diameter  
Weight: 31 grams ( 1.1 oz )  
Cable: 9.14m ( 30 )  
Included: Neck cord assembly, belt clip, for cable and protective pouch



649B

### CO85A

#### Condenser Omnidirectional

Where is it? The CO85 will go unnoticed "on camera" because it is small, and is easily disguised as a tie tac, lapel pin, shirt button, brooch, etc. The electronics that hold the microphone in place are concealed. The CO85 is used normally with battery power, but it also may be powered by wireless transmitters and recorders without using the battery/transformer housing. Response is shaped for wide-range performance in the lavalier chest position. **\$191.00**

### 649B

#### Miniature Dynamic Omnidirectional

Created especially for TV, the small, lightweight 649B is the most popular dynamic lavalier available. The turned aluminum case and nested mechanical parts offer traditional E-V ruggedness. Frequency response is tailored for balanced performance in the lavalier chest position.

**\$132.00**



CO90P

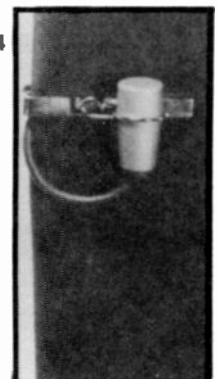

CO94



**Electro-Voice®**

## PROFESSIONAL LOUDSPEAKER/ MONITOR SYSTEMS

### Sentry IVB Professional Loudspeaker System

The Electro-Voice Sentry IVB incorporates many new and innovative design ideas which represent a significant advance in state-of-the-art speaker design. The 3-way, all horn loaded system offers absolute minimum distortion through all frequencies while providing unequalled efficiency and uniformity over the entire frequency range. With high power handling capacity, extremely uniform and wide dispersion, and linear frequency response, the Sentry IVB offers versatility for applications in not only studio monitoring, but in high level sound reinforcement, high level playback systems, etc.

**\$1045.00**

### Sentry® III Series II Professional Monitor System

The Electro-Voice Model Sentry® III Series II is one of a generation of monitor loudspeaker systems resulting from creative engineering and critical listening by Electro-Voice product engineers and product managers. The Sentry III Series II is a direct descendant of the Sentry III and Sentry IVB, utilizing the well known and respected ST350A sectoral tweeter and SM120 sectoral mid-range horn. The vented low-frequency section, utilizing Thiele - Small vented enclosure technology, permits high efficiency and excellent low end performance in a moderate sized enclosure.

**\$1349.00**

### Sentry 100A Professional Monitor

The Electro-Voice Sentry® 100 monitor speaker system is the direct result of "human engineering" with the broadcast/recording studio engineer in mind. Our product engineers' no-nonsense design efforts have culminated in a system that speaks to the needs of professionals with specific requirements: high efficiency with extended low-frequency response, high power capacity across the entire frequency range, uniform frequency response and dispersion, and all in a compact, no-frills package.

**\$220.00**

### SEQ Equalizer

The optional SEQ equalizer extends the low-frequency 3-dB-down point of the Sentry V from 45 Hz to 32 Hz, the Sentry III from 40 Hz to 28 Hz. Such extended low-frequency response is uncommon in the studio but is nonetheless useful where a true indication of low frequency program and noise is desired.

**\$110.00**

### Sentry IVB Components

HSFA—high frequency sub assembly with crossover.

**\$430.00**

#### SPECIFICATIONS

**Frequency Response:**  
50 to 18,000 Hz  
**EIA Sensitivity (on axis measurements):**  
52 dB  
**Sound Pressure Level (4' on axis, 50 W):**  
117 dB  
**Impedance:**  
8 ohms nominal  
**Power Handling Capacity:**  
50 W  
**Finish:**  
Utility Black  
**Size:**  
70.5 cm (27 3/4") w. x 52.3 cm  
(20 5/8") d. x 129 cm  
(50 3/4") h. - in normal configuration  
**Weight:**  
67 Kg (148 pounds)

**Frequency Response:**  
40 to 18,000 Hz  
Normal Mode  
**Sound Pressure Level at 1 Meter, 50 Watts, 300-2,000 Hz  
Average:**  
114 dB  
**EIA Sensitivity Rating (on axis measurements):**  
47 dB  
**Long-Term Average Power-Handling Capacity:**  
40 to 10 kHz  
50 watts  
**Nominal Impedance**  
8 ohms  
**Size**  
**Cabinet:**  
87.6 cm (34 5/8") high  
72.4 cm (28 5/8") wide  
52 cm (20.5") deep  
**Pedestal:**  
3.8 cm (1 5/8") high  
**Weight:**  
70.8 kg (156 lbs)

#### SPECIFICATIONS

**Frequency Response:**  
45 to 18,000 Hz  
**EIA Sensitivity (on axis measurements):**  
41.8 dB  
**Sound Pressure Level (1 Meter, 1 W):**  
91 dB  
**Impedance:**  
6 ohms nominal  
**Power Handling Capacity:**  
30 W  
**Size:**  
30.5 cm (12.00") wide  
28.2 cm (11.125") deep  
43.8 cm (17.25") high  
**Weight:**  
12.7 Kg (28 lb.)

**Total Harmonic Distortion:** Less than .01%, 1 V RMS input, 20-20,000 Hz  
**Intermodulation Distortion:** .005%, 1.5 V RMS equivalent sine wave input  
**Maximum Input Signal:** 7 V RMS sine wave, midband  
**Noise Output:** 80 dB below 200 mV, 20-20,000 Hz bandwidth  
**Controls:** High Frequency Slope (Power Off, 0 dB, -3 dB, -6 dB at 10,000 Hz); Tape-Source  
**Power Requirement:** 110/120 V, 50/60 Hz, 3 watts  
**AC Accessory Outlet:** 200 watts, unswitched  
**Dimensions:** 5.1 cm (2") high; 20.3 (8") wide; 17.8 (8") deep

**LFSA—low frequency sub assembly**

**\$725.00**

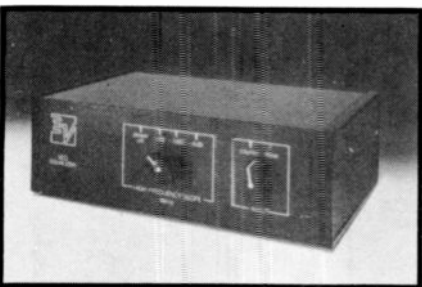
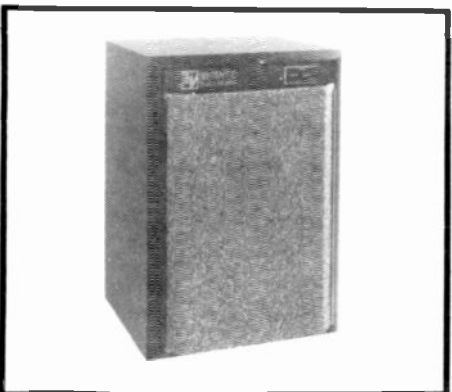
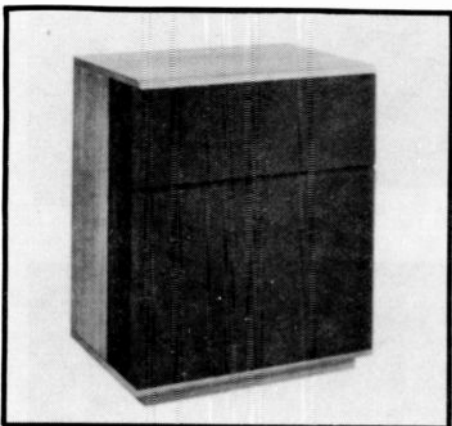
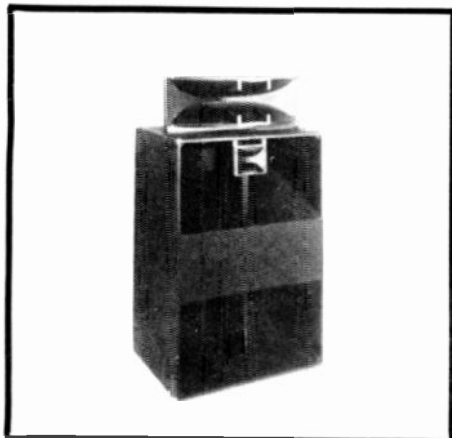



Electro-Voice®



## MICROPHONE ACCESSORIES

301	1" Clamp, black (670)	\$ 7.80	423A	Desk Stand, 5/8" — 27 threaded 5" riser	15.50
301A	1" Clamp, gray	7.80	428	Touch-to-Talk Stand DPDT, 5/8" — 27 thread	46.00
304A	Shock mount for SE15B	34.05	456	Single Carrying Case (Universal: fits all variations of 626, 627, 631, 660, 661, 664, 670, 671, 672)	17.75
307	Shock mount for 3/4" dia. microphones	45.15	502C	Matching Transformer, Lo to Hi-Z, inline	30.00
309	Shock mount for RE20 and SE15B	61.35	502CP	Matching Transformer, Lo to Hi-Z, w/ plug	30.00
310	3/4" Clamp, black (635A, 649B, DO54, DS35, PE15A, RE10, RE11, RE15, RE16, RE55)	7.80	506A	Adaptor (converts 1776A to phantom powerable)	17.25
310A	3/4" Clamp, gray (same applications as 310)	7.80	513A	100 Hz Cutoff Filter	91.95
312	3/4" Snap-out Clamp, black (same applics. as 310)	7.80	520	15' Cable — 1/4" Phone Plug, equipment end with Professional 3-Pin Connectors, microphone end	27.50
312A	3/4" Snap-out Clamp, gray (same applics. as 310)	7.80	521	25' Professional Cable, with Professional 3-Pin Connectors, both ends	31.50
312B	3/4" Snap-out Clamp, beige (DO56, RE18)	7.80	523	4.5 V Alkaline battery — 1776 (12 per box)	35.00
313A	Shock mount for 3/4" diameter microphone	26.40	524A	Windscreen (664)	14.15
314	Windscreen (RE10, RE15)	14.55	541	25' professional cable A3F mike end	24.50
314E	Windscreen (635A)	7.80	542	25' professional cable A3F and A3M connectors	28.00
315A	Windscreen (foam — CH15E, CO15E, CS15E)	7.80	543	25' professional cable with switch connector mike end	37.00
317	Windscreen for CH15S (requires 304A)	16.95	544	50' professional cable A3F and A3M connectors	43.50
335A	Windscreen (630, 634)	17.25	AC24M	Remote AC power supply for condenser microphones	114.50
337	Windscreen (626, 627)	8.50	AC24S	Expander Module (cannot be used without AC24M)	97.50
340	Security Clamp — 3/4" dia. mikes	17.40	BS9	9 volt battery supply for the SE15B and PE15A	66.90
342	Stud Mount Adapter w/ on-off switch	33.50	CA10	10 dB attenuator for use between mike capsule and electronics	35.70
343	Windscreen (CL42E, DL42)	33.45	CO9PM	Power module for CO85A, CO90	69.60
351	Windscreen (DO56), Popfilter (RE18)	7.80	CO9R	Replacement cable assembly for CO90/CO90E	30.17
355A	Windscreen (RE55, DO54, 654A, 655C)	7.80	512	CO85A and CO90 Connector Adaptor Kit	37.65
358	Stand Clamp, tapered (660, 671)	7.80	522	Extension cable for CO94	25.00
360	Windscreen (660, 661, 664)	14.15	28065	Bulk Acoustifoam 36" x 72" x 1/4"	22.70
368	Windscreen for 667A, 668, 307, 309	110.00			
376	Windscreen (DS35), Popfilter (RE11, RE16)	12.00			
380	10 dB Attenuator	32.25			
381	Switch/Connector Cable 15'	33.50			
390	Dual microphone tie clasp (CO90, CO90P, CO94)	6.00			
400	Desk Stand, for all stud or clamp-type mikes	17.70			
411	Stage Mike Mount	16.20			
422	Desk Stand, clamp-type mike (CS15, DO54, DO56, DS35, PE15A, RE10, RE11, RE15, RE16, RE18, RE50, RE55, 340, 635A, and 649B)	19.35			

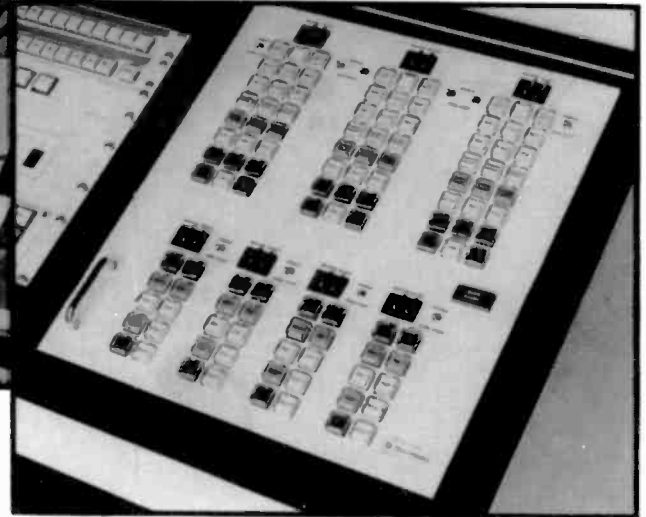

Automax

**TCS-1 Machine Control System**

- Controls up to 100 VTR's/film chains
- Dual twisted pair wiring simplifies installation
- Control of each VTR/film chain can be delegated to any one of eight studio control panels or machine control multiplexers:
  - Each studio control panel can operate up to four VTR's and three film chains simultaneously; each includes a "Gang-Start" switch. (custom configurations available)
  - Each machine control multiplexer can accommodate up to 30 MC-24 control panels
- Central microprocessor can be programmed to provide special functions, such as permanent assignment of specific machines to specific control panels
- System can be integrated with TeleMation\* TVS/TAS-1000 Distribution Switcher to provide dynamic machine selection

\* TeleMation is a trademark of Fernseh Inc.

The TCS-1 is a microprocessor/software based machine control system designed to operate up to 100 videotape recorders and/or telecine film chains. It eliminates patch panels or complex relay switching systems where it is desirable to delegate control of machines to various points. Connection between the control panels and the VTR's/film chains is accomplished with dual twisted pair audio-type wiring, rather than the multiple-conductor cabling normally used with remote controls. The system includes provisions for assigning specific machines to specific control panels, eliminating the possibility of conflicting or unauthorized control commands reaching the same machine from different control stations.

MI-8	8-Function Machine Interface	\$1675.00
MI-24	24-Function Machine Interface	2095.00
MD-8	Machine Delegate Panel	290.00
MC-200	Studio Control Panel	6950.00
MC-24	Single-machine Control Panel, requires MCM-1000. Includes space for one CP-1200A or BP-1200	1350.00
MCM-1000	Machine Control Multiplexer, connects with up to 30 MC-24's	1050.00
DC-1	Dynamic Machine Selector, connects with up to 6 MD-8's and 30 MI-8/24's (must be used in connection with Fernseh Inc. TVS/TAS-1000 Distribution Switcher)	1780.00
CP-1200A	Single-bus Control Panel, with audio breakaway, mounts in MC-24	550.00

TCS-1

BP-1200	Blank panel, mounts in MC-24 not having CP-1200A	10.00
MI-1002	Machine Interface for Ampex VPR-2	1350.00
MI-1003	Machine Interface for Ampex AVR-3	1350.00
MI-2050	Machine Interface for Bosch BCN	1350.00

**Automax Machine Control and Switching System**

- Programmable, Real-time Clock Control of VTR's and Program Distribution
- CRT Terminal for Event Entry and Editing
- System Memory Contains up to 1000 Events (Expanded Memory Also Available)
- Programmable Events Include: Event Number; Day and Time of Event; VTR Play, Record, and Rewind Instructions; Source and Destination Program Switching Instructions; Printout of Events for the Day
- Automatic Control Continues During Event Entry/Edit
- Automatic Look-ahead Display of Upcoming Events
- Manual Control of Events via CRT Terminal or Standard VTR/Switcher Control Panels
- Automatic, Printed Log of Programmed and Manual Events

The Automax Machine Control and Switching System employs microprocessor electronics, machine control interfaces, audio/video switching equipment, a high-speed printer, and a CRT data entry terminal to provide programmable, real-time clock control of videotape recorders and program distribution. As a software-based system, Automax can be custom configured for a wide range of machine control and switching applications, including automation of educational networks and cable television systems. The system combines microprocessor control with hardware and software technology previously developed for the Fernseh Inc. TVS/TAS-1000 Video/Audio Distribution Switcher and TCS-1 Machine Control System.

**AUTOMAX™ MACHINE CONTROL AND SWITCHING SYSTEM**  
 Call for custom quote on Automax systems.

# FERNSEH INC.

the Video Corporation of  
Bell & Howell and Robert Bosch

## AUTOMATED EQUIPMENT

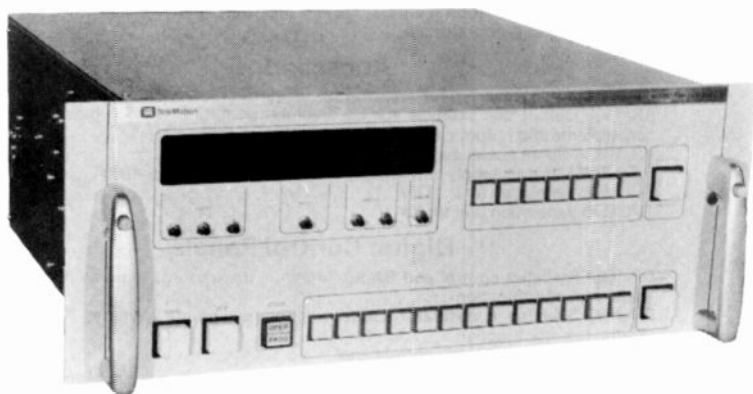

### TMP-2400C Digital Electronic Programmer

#### Features

- Solid-state RAM memory
- High capacity — up to 2,800 events weekly
- 13-channel control capability
- Simplified programming
- "Minute" programming standard
- Real-time switching
- Solid-state reliability
- Automatic changeover to battery standby
- Built-in charger for standby battery
- Compact — only 7" vertical rack space

The TMP-2400C Digital Electronic Programmer has been designed primarily for controlling CATV non-duplication switching, but may also be used in a variety of industrial control applications. The TMP-2400C is self-contained, solid-state, and capable of handling up to thirteen separate output channels. The unit operates on a real-time basis, and 400 separate events can be programmed for a 24-hour period, allowing for up to 2,800 events weekly.

#### Digital Electronic Programmer

TMP-2400C Digital Electronic Programmer, provides 13-channel control with logic-level outputs .....\$6295.00

#### Accessories

SI-2400A Switcher Control Unit, converts logic levels to 24-volt DC coil voltage .....	520.00
TCT-150 Control Transmitter, 15-channel input, accepts logic level inputs and provides RS-232 output .....	1150.00
CT-150 Originate Modem, plugs into TCT-150 .....	345.00
TCR-150 Control Receiver, 15-channel output. Accepts RS-232 input and provides logic-level outputs .....	1045.00
RL-105 Relay Module, provides 15 form "C" contact closures, plugs into TCR-150 .....	415.00
CR-150 Answer Modem, plugs into TCR-150 .....	475.00
CC-1215 Cable Assembly, TCR-150 to SI-2400 .....	68.00
CC-1216 Cable Assembly, TCT-150 to TMP-2400C .....	68.00
CN-505 Connector, 9-pin data out, TCT-150 .....	10.00
CN-506 Connector, 9-pin data in, TCR-150 .....	10.00
CN-507 Connector, 25-pin, switch-control input and output, TCT/TCR-150 .....	15.00

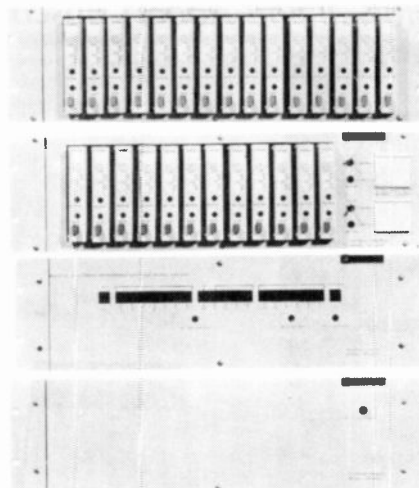

### TMP-1000 Digital Electronic Programmer/Switcher

#### Features

- Simplified programming
- Totally solid-state — no moving parts
- Minute accuracy programming
- Time coincidence switching
- Video and control switching circuitry included
- Provides switched output to control external devices
- Plug-in program cards control event "start" and "stop"
- Events may be repeated up to seven days per week
- Building block system — channel and event capacity may be expanded to meet requirements
- Choice of 2-input/1-output, 3-input/1-output switching
- Ideal for CATV non-duplication
- Suitable for industrial control applications

The TMP-1000 solid-state, digital programmer provides accurate and reliable switching of events in increments as small as one minute. The system accommodates CATV non-duplication switching and industrial apparatus control requirements and is built on a building block approach, allowing a TMP-1000 system to be tailored to any specific user application. Channel and event capacity may be specified to meet immediate requirements, yet allow for true "add-on" system expansion.

#### Digital Electronic Programmer/Switcher

MS-6099 TMP-1000 Digital Electronic Programmer/Switcher, Includes: MC-1000 Digital Master Clock, OC-1000 Output Control Chassis, provides 2-channel control, will accept up to 12 program cards .....\$1205.00

#### Accessories

EE-1000 Event Expander Chassis, accommodates up to 15 program cards .. \$	475.00
OC-1000 Output Control Chassis, each chassis provides control for 2 additional channels .....	475.00
PC-1000 Program Card, one required for each event .....	55.00
SP-1000 Standby Power Source, requires external 12-volt lead acid or gel cell batteries .....	520.00
TCT-150 Control Transmitter, 15-channel, accepts contact closure inputs and provides RS-232 output .....	1150.00
CT-150 Originate Modem, plugs into TCT-150 .....	345.00
TCR-150 Control Receiver, 15-channel output, accepts RS-232 input and provides logic-level outputs .....	1045.00
RL-105 Relay Module, provides 15 form "C" contact closures, plugs into TCR-150 .....	415.00
SI-2400 Switcher Control Unit, converts logic levels to 24 VDC coil voltages .....	520.00
CR-150 Answer Modem, plugs into TCR-150 .....	475.00
CC-1215 Cable Assembly, TCR-150 to SI-2400 .....	68.00
CC-1216 Cable Assembly, TCT-150 to TMP-2400C .....	68.00
CN-505 Connector, 9-pin data out, TCT-150 .....	10.00
CN-506 Connector, 9-pin data in, TCR-150 .....	10.00
CN-507 Connector, 25-pin, switch-control input and output, TCT/TCR-150 .....	15.00

Prices and Specifications Subject to Change Without Notice.

# FERNSEH INC.

the Video Corporation of  
Bell & Howell and Robert Bosch

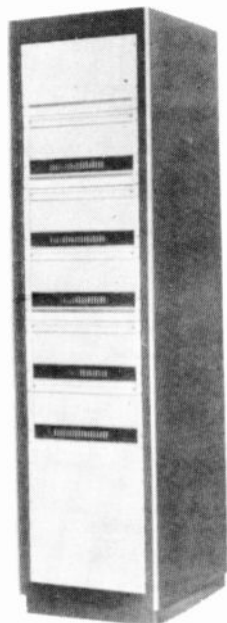

40 x 50

AFV Switcher



CP-1001

## TVS/TAS-1000 Video/Audio Distribution Switching Systems

### Features

- Compact—up to 1000 crosspoints per 8 3/4" chassis
- Solid-state crosspoints with vertical interval switching
- Single-Coax "Party-Line" control
- Wide selection of bus controls and status monitors
- Microprocessor/computer control
- Can be interfaced with Fernseh TCS-1 Machine control system
- Excellent long-and near-term transfer characteristics
- Automatic restoration after power failure, with refresh memory option
- Dual video outputs
- Standard, multiple-sourced components—no custom hybrids
- Automatic system testing of all circuit parameters through all possible signal paths—hard copy results supplied

TVS/TAS-1000  
VIDEO/AUDIO DISTRIBUTION SYSTEMS (CODE N)  
MATRIX - CAV SERIES

MATRIX SIZE INPUT OUTPUT	VIDEO ONLY LIST	AUDIO ONLY LIST	COMBINED LIST
10 x 10	\$4,710.00	\$4,260.00	\$6,750.00
20 x 10	6,525.00	5,845.00	10,150.00
30 x 10	8,340.00	7,435.00	13,555.00
40 x 10	10,150.00	9,020.00	16,960.00
10 x 20	\$10,610.00	\$ 8,565.00	\$13,555.00
20 x 20	14,235.00	11,740.00	20,360.00
30 x 20	17,865.00	14,915.00	27,165.00
40 x 20	21,495.00	18,090.00	33,970.00
10 x 30	\$16,505.00	\$12,875.00	\$20,360.00
20 x 30	21,950.00	17,640.00	30,565.00
30 x 30	27,390.00	22,400.00	40,770.00
40 x 30	32,835.00	27,165.00	50,980.00
10 x 40	\$22,400.00	\$17,185.00	\$27,165.00
20 x 40	29,660.00	23,535.00	40,770.00
30 x 40	36,915.00	29,885.00	54,380.00
40 x 40	44,175.00	36,235.00	67,990.00
10 x 50	\$28,300.00	\$21,495.00	\$33,970.00
20 x 50	37,370.00	29,430.00	50,980.00
30 x 50	46,440.00	37,370.00	67,990.00
40 x 50	55,515.00	45,310.00	85,000.00

### 12-Input Passive Switchers

TVS-12X1T 12X1 terminating switcher ..... \$205.00

## SWITCHING EQUIPMENT

### Matrix MSO Series

Please contact the factory for a special quotation for switchers with 50 or more inputs.

### Options

Audio source termination resistors, factory installed, specify value. Price shown is price per audio output decade ..... \$40.00

### Accessories

EX-876 Module extender, for servicing circuit cards or power supply ..... \$160.00  
 BX-1001 Output bus extender for CAV series, permits in-service maintenance of crosspoints and output cards, requires EX-876 ..... 120.00  
 PS-1000A Spare power supply ..... 675.00  
 PS-1000RK Power supply redundancy kit, one required per PS-1000 ..... 85.00  
 TVU-175 Ventilation unit, 117 V ..... 250.00  
 TVU-176 Ventilation unit for 234 V ..... 275.00

### Digital Control Panels

CP-1001 Switcher control and Status Monitor, deskmount, requires RM-1001 for status monitor function ..... \$1,200.00  
 CP-1002 Switcher control and status monitor, rackmount, requires RM-1001 for status monitor function ..... 1,200.00  
 CP-1006 Six-bus switcher control panel ..... 1,590.00  
 CP-1500/1 Alphanumeric Switcher Control and Status Monitor, single rackmount ..... \$1500.00  
 CP-1500/2 Alphanumeric Switcher Control and Status Monitor, dual rackmount ..... \$2850.00  
 CP-1500D Alphanumeric Switcher Control and Status Monitor, desktop ..... \$1500.00  
 CP-1550 Alphanumeric Lever Wheel Control and Status Monitor, rackmount ..... \$1500.00  
 RM-1001 Refresh memory, required for status monitoring function of CP-1001/1002 ..... 810.00

### BCD Control Panels

NOTE: BCD Control Panel interface to switching matrix is via CM-1020 or CM-1200 Control Multiplexers. However, if true status indication is required, or if multiple audio-only and video-only bus controls are required, specify CM-1200.

CP-1004A/1 Lever Switch Remote Control Panel, rackmount, requires CC-1010 Cable ..... \$130.00  
 CP-1004A/2 Dual Lever Switch Remote Control Panel, rackmount, requires two CC-1010 Cables ..... 270.00  
 CP-1004A/3 Triple Lever Switch Remote Control Panel, rackmount, requires three CC-1010 Cables ..... 370.00  
 CP-1005A Deskmount Lever Switch Remote Control, requires CC-1010 ..... 275.00  
 CP-1010 Category/Number Control Panel, requires CC-1010 Cable ..... 550.00  
 CP-1011 Category/Number Control Panel with TAKE Button, requires CC-1010 Cable ..... 550.00  
 CP-1020 20-Pushbutton Control Panel requires CC-1010 Cable ..... 550.00  
 CP-1021 20-Pushbutton Expansion for CP-1020 ..... 225.00  
 CP-1200A/1 Single-bus Control Panel, with audio breakaway, single-unit rackmount, requires CM-1200 in system and 1 ea. CC-1010 ..... 550.00  
 CP-1200A/2 Dual-bus version of CP-1200A above, requires CM-1200 in system and 2 ea. CC-1010 ..... 1,075.00  
 CP-1200A/3 Triple-bus version of CP-1200A above, requires CM-1200 in system and 3 ea. CC-1010 ..... 1,600.00  
 CP-1200A/D Desktop version of CP-1200A above, requires CM-1200 in system and 1 ea. CC-1010 ..... 535.00  
 CM-1020 Control Multiplexer, for up to 6 buses ..... 1,050.00  
 CM-1200 Control Multiplexer, for up to 12 buses ..... 1,615.00

### Status Monitor

NOTE: Requires RM-1001 in system

SM-1000 Full Matrix CRT Status Display Generator ..... \$2045.00

### Computer and Dataphone Control Accessories

CI-1030 EIA RS-232 Interface ..... \$730.00  
 CI-1060 EIA RS-232 Party line/status interface (subject to additional programming charge) ..... 1,615.00

### Connecting Cable

CC-1010/25 Connecting cable, 25 ft. .... \$70.00  
 CC-1010/50 Connecting cable, 50 ft. .... 85.00  
 CC-1010/100 Connecting cable, 100 ft. .... 125.00  
 CC-1010/200 Connecting cable, 200 ft. .... 195.00  
 CC-1010/XXX Connecting cable, specify length ..... 55.00  
 + 70/ft.

### Card Frame/Rack Space Requirements

- (A) Type CAV-single 8 3/4" card frame for both audio and video  
 (B) TVU-175 Ventilation unit-one 1 3/4" exhaust blower is provided for each two 8 3/4" card frames



# FERNSEH INC.

the Video Corporation of  
Bell & Howell and Robert Bosch

## TERMINAL EQUIPMENT

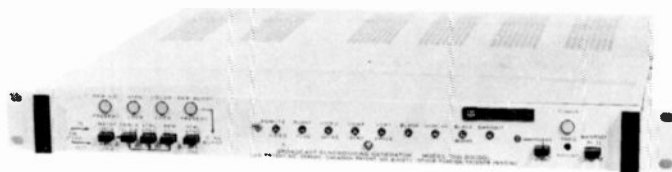

### TSG-3000 GL\*Broadcast Color Synchronizing Generator

#### Features

- All-digital circuitry
- Two modes of digital-stability genlock operator-controlled choice of:  
INSTANTLOCK — Instantaneous Lock-Up  
RATELOCK — Uniform-Rate Lock-Up
- Ultra-stable pulses and color subcarrier
- All pulse widths programmable
- Bar-dot generator standard equipment
- Built-in black burst generator standard
- Front-panel test points provided
- Mounts in 1-3/4" vertical rack space

\*U.S. Patent 3581011, Canadian Patent 870277. Other world patents pending.

The digital design concept developed by Fernseh Inc. in the manufacture of broadcast synchronizing generators assures the lowest pulse jitter, highest time base stability available. No delay lines are required and no multi-vibrators are used. Timing adjustment to compensate for circuit instability are thereby eliminated, as are the possibilities of maladjustment or circuit drift.

- TSG-3000GL NTSC Broadcast Sync Generator with Built-in Bar Dot and Blackburst Generators and Digital Genlock ..... \$2,620.00
- TSG-4000 RS-170A Sync Generator, NTSC ..... 2,330.00

### PAL Sync Generators — 625-Line/50 Hz PAL

- TSG-2001B PAL-I Sync Pulse Generator ..... 3,200.00
- TSG-2001B-1 PAL-B, -G and -H Sync Pulse Generator ..... 3,200.00

#### Accessories

- GL-2001B PAL Color Genlock ..... 975.00
- BD-2001/2B Bar Dot Generator ..... 225.00

### PAL-M Sync Generator

- TSG-2002B PAL-M Sync Generator ..... 3,200.00

#### Accessories

- GL-2002B PAL-M Color Genlock ..... 975.00
- BD-2001/2B Bar Dot Generator ..... 225.00

### Hum Eliminator

- THE-100 Hum Eliminator ..... 125.00

### "551" Series Terminal Equipment

NOTE: This equipment mounts in an RF-551 Rack Frame or MB-551 Mounting Box.

- TMV-551 Video Distribution Amplifier ..... 275.00
- TPA-551 Pulse Distribution Amplifier ..... 275.00
- RF-551 Rack Frame ..... 80.00
- MB-551 Mounting Box ..... 50.00
- BP-551 Blank Panel ..... 25.00

Prices and Specifications Subject to Change Without Notice.

### TSG-4000 RS-170A Sync Generator

#### Features

- All Digital • Color Field Identification • Multi-Mode Genlock • Automatic SC/H Phasing • Built-In Reference Blackburst • Genlock Input SC/H Status Monitor • LED Display of Operating Mode • All Pulse Widths Programmable • Front-Panel Test Point for SC/H Phase Verification • Mounts in 1 3/4" Vertical Rack Space

The TSG-4000 is a full-feature master sync generator with all operations fully compatible with the new EIA standard RS-170A.

RS-170A is a revised standard for synchronizing pulse waveforms for broadcast television. The primary revision deals with the phase relationship between the sync pulse and the color subcarrier. In the previous standard RS-170, this relationship was somewhat ambiguous, leading to problems in program interchange and editing.

In addition to accommodating the requirements of RS-170A, the TSG-4000 incorporates a new frame I.D. pulse system which uses a color subcarrier burst on a designated line in the vertical blanking interval. This system provides for positive identification of one field in the four-field sequence, permitting accurate synchronization of equipment, especially in editing systems where color framing accuracy is critically important in producing clean tapes for broadcast. **\$2330.00**

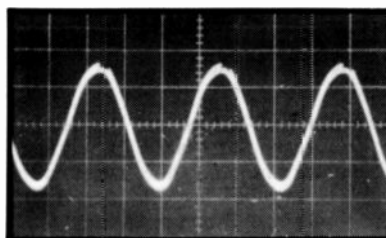

Incoming Video with 16V P-P hum superimposed (5 V/Division)

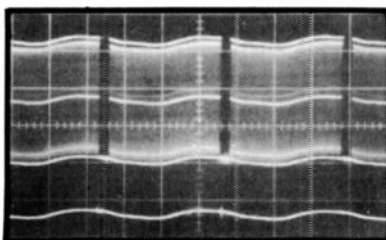

Outgoing Video with 50 mV P-P hum: attenuation of 50 dB. (200 mV/Division)



### THE-100 Hum Eliminator

#### FEATURES

- For use in color and monochrome systems
- Greatly reduces common mode power line hum in video circuits
- Passive, failure-free
- Compact
- Flat frequency response
- No differential phase or gain distortion

The TeleMation\*\* THE-100 greatly reduces common mode hum caused by differences in ground potential as frequently encountered in installations with long video cables, incoming and outgoing lines, or separate power distribution systems.

\*\*TeleMation is a trademark of Fernseh Inc.

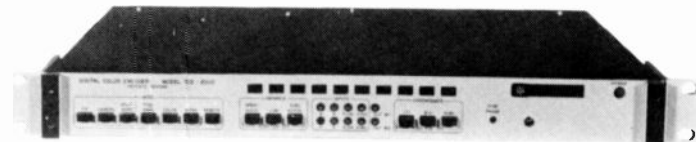
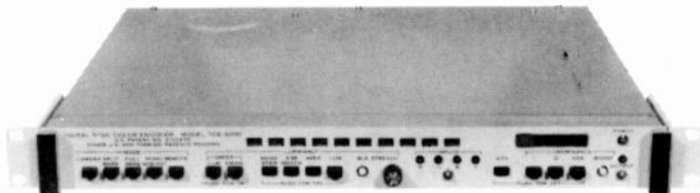

**TCE-3000 Digital Color Encoder**

**Features**

- Digital modulators
- All-digital color bar generator — full/split bars (+/-0.5% gain, +/-0.5° phase stability)
- Noise stripping standard — reduces white noise for SNR improvement
- Luminance black stretch
- Level dependent proportional aperture correction
- 100% circuit access during operation — no phase shift — no gain change
- Remote chroma boost — ideal for film
- Greater than 50 dB residual subcarrier rejection
- Digital phasing
- VITS color bars/VIRS line and field selectable (optional)
- DC coupling/clamping throughout
- Green highs mode for crispening
- Green luminance mode
- Meets all specifications over 100-130 VAC, 0°-60° C range

The TeleMation® TCE-3000 Digital Color Encoder produces NTSC encoded color signals and is designed for use with both live and film cameras, three-or-four-tube types. All video inputs to the Encoder are compensated, bridging inputs, with excellent return loss characteristics.

Provision is made to allow rewiring of the Y (luminance) input to be a "derived" luminance output, for ready integration of vertical aperture equalizers or contour enhancers requiring this signal with three-tube camera systems. In three-tube camera operation, enhancement may be either Mixed Highs from Green (high frequency information from the green channel), or Green Luminance mode (Green = Luminance). The Green Highs mode is especially useful to provide a "crispended" horizontally enhanced signal that is frequently desired with three-tube cameras. The Green Luminance mode provides a suitable means to lessen the possibility of gross mis-registration, and is also ideal in outdoor operation to increase contrast against the sky as light conditions change (darkens blue).

A notch filter, centered at the subcarrier frequency (3.58 MHz) is front panel switchable. Monochrome outputs are provided with or without burst. A Green Tie mode may be selected where green video is routed to the blue and red inputs to allow for proper monochrome outputs in the event of a failure of either the red or blue camera tube. The TCE-3000 Encoder, when operated in the four-tube (RGBY) Mode, provides adjustable Livingston Error Compensation to allow tailoring of the Y channel to provide correct luminance levels for all colors. This is accomplished by allowing the correct amount of the matrixed Y signal to be added to the separate luminance input signal.

Separate output amplifiers are provided for the program and monitor outputs.

The TCE-3000 Encoder provides up to 10 dB of aperture correction at 4.0 MHz. Aperture correction is proportional, level dependent, with aperture threshold adjustable and aperture boost adjustable to 12 dB.

**TCE-2000 Digital Color Encoders  
 For NTSC/PAL/PAL-M Systems**

**Features**

- Available for NTSC, PAL-I, PAL B, G, and H or PAL-M operation
- Drift-free digital modulators (U.S. Patent No. 3721755)
- All-digital color bar generator — full/split bars — optional
- Level-dependent proportional aperture correction
- 100% circuit access during operation — no extenders required — no phase shift or gain change during adjustment
- Umbilical connection for instant service replacement
- Remote chroma boost — ideal for film
- Subcarrier rejection typically 55 dB
- No DC shift with APL change
- Drift-free current summing matrices (U.S. Patent No. 3715470)
- Meets all specifications over 100-130 VAC, 0°-60°C range without readjustment

TeleMation® Series TCE-2000 Digital Color Encoders are available to produce NTSC, PAL or PAL-M encoded color signals according to NTSC, CCIR and EBU specifications. With the use of digital circuitry and precision components, TeleMation has minimized set-up and maintenance requirements on the TCE-2000 Series.

The TCE-2000 Encoders are designed for use with both live and film cameras, either three or four-tube types. All inputs are bridging with looping jacks provided. Compensation networks assure excellent input return loss characteristics.

**NTSC Color Encoders**

<b>TCE-3000</b>	Digital NTSC Color Encoder with Color Bar Generator .....	<b>\$3,995.00</b>
-----------------	---	-------------------

**Accessories**

<b>RC-3000EN</b>	Encoder Remote Control Module, mounts in RP-203* Rack Panel. Requires CC-3000 *See Section 13. ....	<b>295.00</b>
<b>CC-3000/XXX</b>	Connecting Cable, specify length .....	<b>45.00</b>
		+ 1.30/ft.
<b>TCE-2000N</b>	NTSC Digital Color Encoder .....	<b>3,460.00</b>

**Accessories**

<b>BG-2000</b>	Digital Color Bar Generator .....	<b>315.00</b>
<b>PD-2000</b>	Pulse Delay Module .....	<b>160.00</b>

**PAL Color Encoders**

<b>TCE-2000P</b>	PAL-I Digital Color Encoder .....	<b>4,110.00</b>
<b>TCE-2000P-1</b>	PAL-B, -G, and -H Digital Color Encoder .....	<b>4,110.00</b>
<b>TCE-2000M</b>	PAL-M Digital Color Encoder .....	<b>4,110.00</b>

**Accessories**

<b>BG-2000</b>	Digital Color Bar Generator .....	<b>320.00</b>
<b>PD-2000</b>	Pulse Delay Module .....	<b>160.00</b>

\*TeleMation is a trademark of Fernseh Inc.

Prices and specifications subject to change without notice

# FERNSEH INC.

the Video Corporation of  
Bell & Howell and Robert Bosch

## TERMINAL EQUIPMENT AND SWITCHING

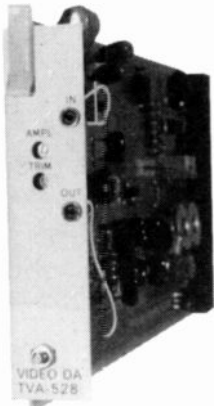

TVA-528

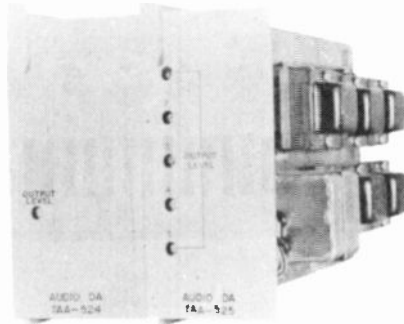

TAA-524/525

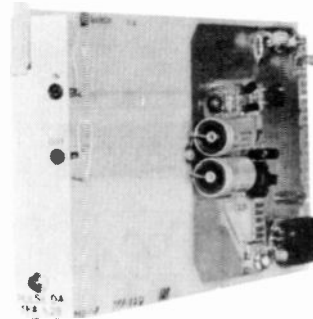

TPA-528

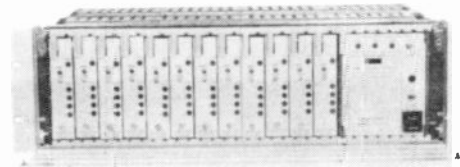

RF-525

### "525" Series NTSC Sync Generator Modules

NOTE: Modules may be installed in RF-525 or RF-175 Rack Frames.  
Please specify with order.

TSG-525 Sync Generator, select appropriate connecting panel among IP-1, IP-2, IP-3, IP-6	..... \$555.00
GL-525 Genlock Accessory, select IP-2, IP-3 or IP-6	..... 555.00
CO-525 Sync Changeover Accessory, requires IP-6	..... 425.00
BD-525 Bar Dot Accessory, to be used with IP-3 or IP-6 connecting panel configurations	..... 375.00

### ACCESSORIES

#### Connecting Panels for "525" Sync Generator Systems

IP-1 Connecting panel and Card connector for mounting TSG-525 in RF-175 or RF-525 rack frames. Required only where TSG-525 is to be used without GL, CO, or BD accessories.	..... \$65.00
IP-2 Connecting panel and Motherboard for mounting TSG-525 and GL-525. Occupies two frame spaces	..... 155.00
IP-3 Connecting panel and Motherboard for mounting TSG-525, GL-525, and BD-525 in RF-525 rack frame. Occupies three frame spaces	..... 210.00
IP-6 Connecting panel and Motherboard for mounting one CO-525, two TSG-525's, two GL-525's and one BD-525 in RF-525 rack frame. Occupies six frame spaces	..... 300.00

### "525" Series Equipment

NOTE: Modules may be installed in RF-525 or RF-175 Rack Frames.  
Please specify with order.

#### Blackburst Generators

TBB-525 Blackburst Generator	..... \$700.00
------------------------------	----------------

#### Distribution Amplifiers

TVA-524 Broadcast Video Distribution Amplifier	..... \$280.00
TVA-528 Precision Video Distribution Amplifier	..... 350.00
TVA-528D Precision Video Distribution Amplifier with DL-525 Delay Plug-in Accessory	..... 635.00
TVA-528E Precision Video Distribution Amplifier with EQ-525 Equalizer Plug-in Accessory	..... 420.00
TVA-528DE Precision Video Distribution Amplifier with both DL-525 and EQ-525 plug-in accessories	..... 695.00
TPA-527 Precision Pulse Distribution Amplifier, with individual delay	..... 345.00
TPA-528 Broadcast Pulse Distribution Amplifier; 6 output	..... 250.00
TPA-529 Precision Pulse Distribution Amplifier; 6 output	..... 295.00
TSA-525 Subcarrier distribution amplifier with individual 370° phase adjustments	..... 550.00

### Accessories

DL-525 Delay plug-in for TVA-528	..... \$285.00
EQ-525 Equalizer plug-in for TVA-528	..... 60.00

### Source Identifier

TCG-4 Dual source identifier, 1" mounts in RF-525. Only one unit can be mounted in an RF-175	..... \$480.00
--	----------------

### Audio Distribution and Monitor Amplifiers

NOTE: Modules may be installed in RF-525 Rack frames. Please specify with order

TAA-524 Audio Distribution Amplifier	..... \$280.00
TAA-525 Audio Distribution Amplifier, transformer outputs	..... 450.00
TMA-525 Audio Monitor Amplifier, 15 watt	..... 330.00

### "525" Series Modular Video and Audio Switchers

NOTE: 1. Each TVS/TAS-525 mounts in a RF-525 Rack Frame. Specify factory installation with the order if desired. 2. Any audio or video switcher larger than 10 x 1 requires a factory quotation for price.

TVS-525 5 x 1 Video switcher module	..... \$430.00
TAS-525 5 x 1 Audio switcher module	..... 450.00

### Accessories

RC-5 5-pushbutton remote control panel, mounts in RP-203	..... \$175.00
RP-203 Rack panel for up to three remote control panels	..... 75.00
CC-5/25 Connecting cable, 25 ft.	..... 55.00
CC-5/50 Connecting cable, 50 ft.	..... 65.00

### Rack Frames and Power Supplies

NOTE: A PS-525 Power Supply must be ordered with each RF-525 Rack Frame. The RF-175 Rack Frame contains a built-in power supply; therefore, a PS-525 is not required

RF-525 5- 1/4" Rack frame for PS-525 and up to twelve 1" modules	..... \$200.00
PS-525 Power supply	..... 335.00
PS-525RK Power supply Redundancy kit, two required	..... 90.00
RF-175 1 3/4" Rack frame and power supply	..... 430.00
EX-526 Module extender	..... 125.00
RP-203 Rack panel for remote control modules, accommodates up to three modules	..... 75.00
BP-203 Blank panel for RP-203	..... 25.00

### Blank Filler Panels

BP-1 1 3/4" x 19"	..... \$10.00
BP-2 3 1/2" x 19"	..... 15.00
BP-3 5 1/4" x 19"	..... 20.00
BP-4 7" x 19"	..... 25.00
BP-5 8 3/4" x 19"	..... 30.00
BP-6 10 1/2" x 19"	..... 35.00

### Ventilation Units

TVU-175 Ventilation Unit, 117 VAC	..... \$250.00
TVU-176 Ventilation Unit, 234 VAC	..... 275.00

# FERNSEH INC.

the Video Corporation of  
Bell & Howell and Robert Bosch

## SIGNAL PROCESSING EQUIPMENT

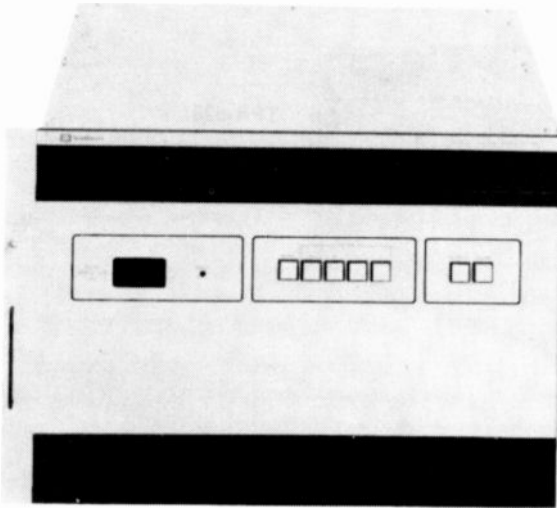

### TDF-2 Digital Noise Filter

#### Features

- Up to 18 dB broadband noise reduction (element-by-element)
- Custom-programmable filter formulas
- 4X subcarrier sampling rate — 477,750 samples per frame
- 3.2 megabit memory capacity
- Full RS-170A processing amplifier
- Self-test systems
- Internal genlock — no external drives required

The new TDF-2 Digital Noise Filter is designed to improve the signal-to-noise ratio of cameras, videotape recorders, and microwave/satellite links by as much as 18 dB. All forms of electronic noise—both high and low frequency—as well as film grain, dust, and dirt encountered during film transfers are dramatically reduced. The TDF-2 is especially useful for SNR improvement of multi-generation videotapes.

The unit is completely automatic, adjusting itself for high noise reduction on still portions of pictures and lowering the amount of noise reduction in those portions containing motion in order to avoid video lag.

The adjustment process is controlled by a programmable read-only memory (PROM) that can be custom-programmed according to your requirements.

As delivered, the TDF-2 is supplied with four standard PROM's, each corresponding to one of the filter switches on the front panel. The PROM parameters have been carefully optimized through computer simulation to provide high SNR improvement with minimum smear distortion of moving objects. After evaluating your program material at each of these settings, you can select the single best filter formula for your application; the TDF-2 can then be permanently installed on your program line and operated continuously without adjustment.

#### Digital Noise Filter

TDF-2 Digital Noise Filter with internal genlock and programmable filter formulas	\$26,500.00
TDF-2/BCN Digital Store and Noise Reducer for BCN VTR's	26,960.00

#### Accessories

MS-2000 Accessory Group, includes RC-2 Remote Control, freeze frame/field, horizontal and vertical image enhancer, and chrominance-to-luminance delay corrector	\$2520.00
MS-2001 TDF-2 Digital Noise Filter, NTSC with Accessory Group	29,020.00
RC-2 Remote Control	925.00
CL-1 Chrominance to Luminance Delay	596.00
HV-1 Horizontal and Vertical Enhancer	596.00

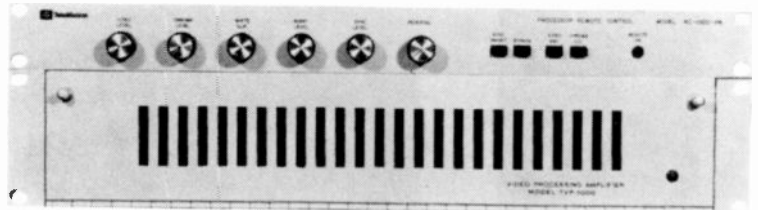

### TVP-1000 Video Processing Amplifier

#### Features

- Full sync, blanking, burst regeneration
- Includes programmable pulse width digital sync generator with genlock
- Differential input rejects up to 30 V P-P Common Mode Hum
- Strappable for operation with helical scan and U-Matic format recorders
- Separate sync, luminance, chrominance and burst processing
- Failsafe compensated metallic-contact bypass
- Full 360° subcarrier phasing
- Full remote control
- Reverts to monochrome black on incoming signal loss
- Luminance and chrominance AGC (optional)
- VIRS AGC Mode — Luminance/chrominance ratio maintained. Loss of VIRS causes reversion to burst AGC mode
- Available for NTSC, PAL, or PAL-M standards
- Selectable AGC responds to VIRS or burst for chroma gain — sync, VIRS or video for luminance gain

The TVP-1000 Video Processing Amplifier meets modern broadcast performance requirements with superior operating features and stability. Handling both color and monochrome signals, the TVP-1000 is designed to operate with quadraplex, helical scan or U-Matic format videotape recorders. Models are available for NTSC, PAL or PAL-M.

A differential amplifier at the processor input, together with an input clamp circuit, provides over 60 dB common mode hum rejection and over 35 dB reduction of single-ended hum. A wide dynamic range permits the circuit to effectively remove over 30 V P-P common mode hum from the incoming video.

#### NTSC Video Processors

TVP-1000N NTSC Video Processor, use with RC-1000 Remote Control recommended	\$3860.00
TVP-1000H NTSC Video Processor for Helical Scan VTR, use with RC-1000 Remote Control recommended	3860.00

#### Accessories

AG-1000 AGC Option	\$670.00
PO-1000N Pulse Output Module	236.00
RC-1000 Remote Control Panel, rackmount	260.00
CC-6/5 Connecting Cable, 5'	86.00
CC-6/10 Connecting Cable, 10'	90.00

# FERNSEH INC.

the Video Corporation of  
Bell & Howell and Robert Bosch

MC 37 BB

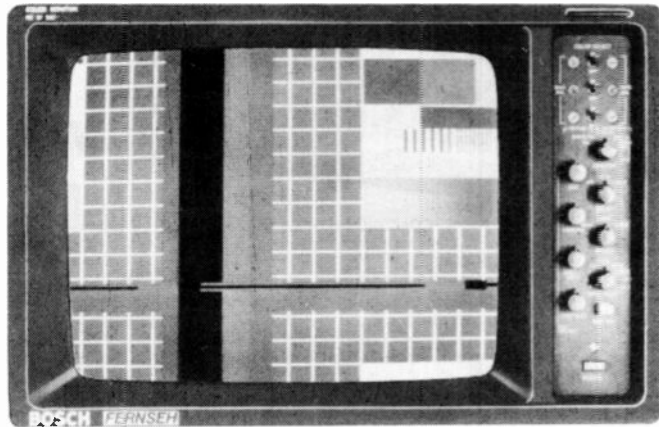

MC 37 BA

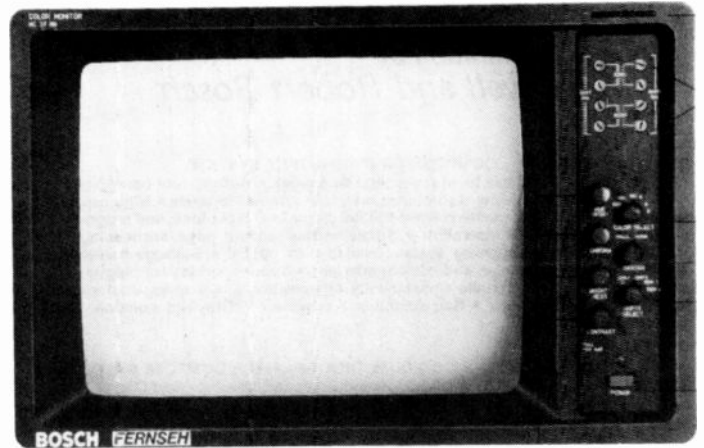

MC 51 BB

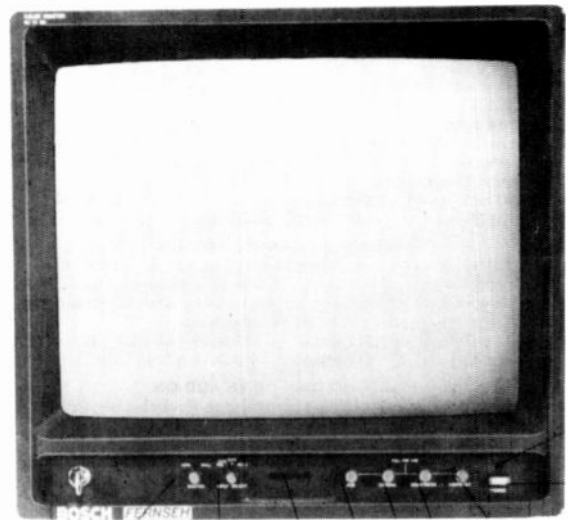

## COLOR MONITORS

### MC 37 BA Precision Color Monitor With 37-cm Screen Diagonal

#### Description

The MC 37 BA precision color monitor can be delivered as a table top unit with metal case or for mounting in racks or cabinets. Three looped through CCVS inputs are provided as well as RGB inputs. The monitor is equipped with a self converging in-line tube and has a screen size of 210 x 280 mm. The basic RGB version can be equipped for CCVS operation in all color systems by the addition of plug-in decoder cards. The monitor can display horizontal sync and the vertical interval as well as the 'pulse cross.' The color difference output signals R-Y and B-Y are independent of contrast and brightness adjustment. Signal input selection, synchronizing mode as well as brightness, chroma, contrast and hue are remotely controllable.

#### Features

- 3 selectable CCVS inputs • Inputs 1 + 3 can be added • Separate RGB input for RGB and CCVS operation • 1 output of selected signal • R-Y, B-Y outputs • Internally or externally synchronizable • In-line tube, self converging • Raster size switchable large/normal/small • Remote control • Blue only pushbutton • PAL/PAL-Simple switchable • Pulse cross

#### Application

The monitor meets broadcast requirements and has been specifically developed for quality monitoring in VTR systems. Due to its light weight and small dimensions it is particularly suitable for O.B. van installation. **\$5,200.00**

### MC 37 BB High-Quality Color Monitor with 37-cm Screen Diagonal

#### Description

The monitor MC 37 BB is available as a table top unit with metal case or for mounting in cabinets or rack. The equipment features two loop-through inputs at 75 ohms. It is equipped with an in-line tube. The screen size is 210 x 280 mm. Input selection, synchronizing mode, brightness, chroma and contrast are remotely controllable. The color difference signals required for the vector display can only be derived from a video section with precision decoder (see order information).

#### Features

- 2 selectable inputs • Internal and external synchronization • RGB, PAL, PAL-M, NTSC or SECAM • In-line tube, self converging • Raster size switchable to "small" • Color temperature switchable 6500/3200 K • Remote control

#### Application

The monitor meets broadcast requirements and has been specifically developed for picture evaluation. Due to its light weight and minimal dimensions it is particularly suitable for O.B. van installation. **\$4,000.00**

### MC 51 BB High-Quality Color Monitor with 51-cm Screen Diagonal

#### Description

The monitor MC 51 BB is available as a table top unit with metal case or for mounting in cabinets or racks. The screen size is 372 x 279 mm. Input selection, synchronizing mode, brightness, chroma and contrast are remotely controllable.

#### Features

- 1 RGB or 2 CCVS inputs for PAL, PAL-M, NTSC or SECAM • Additional RGB input for RGB and CCVS operation (option) • Internally and externally synchronizable • Precision in-line tube, self converging • Raster size switchable to "small" • Color temperature switchable 6500/3200 K • All second order controls in front draw • Remote control

#### Application

The monitor meets broadcast requirements and has been specifically developed for picture evaluation. Due to its light weight and minimal dimensions it is particularly suitable for O.B. van installation. **\$4,800.00**

# FERNSEH INC.

the Video Corporation of  
Bell & Howell and Robert Bosch

## COMPOSITOR II™ GRAPHICS SYSTEM

**FEATURES:** • Adaptable to all alphabetic languages • Multiple font capability • Selectable-width border, shadow, and outline with four luminance levels • High capacity rigid cartridge disk memory contains up to 999 full pages plus eight fonts and program storage • Rapid, simple on-air operation • Single-button random page sequencing • TED-1 automated election reporting system available as option • Software-based system—facilitates future expansion and custom interface • Space provided for plug-in of second character generator—permits simultaneous composition and display, dual independent display, or page preview • Rapid subtitling capability • Graphics compose/animation option

## COMPOSITOR I DUAL CG DUAL DISK GRAPHICS COMPOSE SYSTEM

**Includes:** Compositor I Basic Single System, Second Channel Add-On, CC-1506/200, CC-1507/200, MS-5059, MS-5040, 2 ea. EO-3001 (or EO-3001/1), 2 ea. CM-3002, Requires Sola Transformer, Order MS Number below  
MS-5016 NTSC or PAL-M ..... **\$87,900.00** MS-5018 PAL-I, -G, -B, -H ..... **\$87,900.00**  
MS-5017 525/60 RGB ..... **\$89,900.00** MS-5019 625/50 RGB ..... **\$89,900.00**

## COMPOSITOR I BASIC SINGLE SYSTEM

**Includes:** 32K font memory (space for 1 ea. 24-line, 2 ea. 32-line and 2 ea. 56-line fonts); 24 line Helvetica font; 4 fonts, customer choice from standard font library; Roll and crawl, Character edging (2-line border/outline, 2- or 4-line shadow; 4 luminance levels); Character/background colorizing, 28 colors, 4 luminance levels; Keyboard, TKB-3000 with 100 ft. cable; Rigid cartridge disk drive, with 1 ea. cartridge; System terminal; Paper tape reader; Standard system software; One year software update; Connecting cables, mounting hardware and module extenders; On-site installation; Factory production training, 4 places; Factory technical training, 2 places (no travel expenses paid by Fernseh), Requires Sola Transformer, Order MS Number below:  
MS-5006 NTSC or PAL-M ..... **\$46,600.00** MS-5008 PAL-I, -G, -B, -H ..... **\$46,600.00**  
MS-5007 525/60 RGB ..... **\$47,300.00** MS-5009 625/50 RGB ..... **\$47,300.00**

## SECOND CHANNEL ADD-ON

**Includes:** 32K font memory (space for 1 ea. 24-line, 2 ea. 32-line and 2 ea. 56-line fonts), Roll and Crawl; Character edging (2 line border/outline, 2- or 4-line shadow, 4 luminance levels, Character/background colorizing, 28 colors, 4 luminance levels; Keyboard, TKB-3000 with 100 ft. cable; Connecting cable, Order MS Number below  
MS-5011 NTSC or PAL-M ..... **\$12,600.00** MS-5013 PAL-I, -G, -B, -H ..... **\$12,600.00**  
MS-5012 525/60 RGB ..... **\$13,650.00** MS-5014 625/50 RGB ..... **\$13,650.00**

## SECOND DISK DRIVE ADD-ON

**Includes:** Rigid cartridge disk drive, with 1 ea. cartridge, Power supply, Mounting hardware, Connecting cables, Order MS Number below:  
MS-5050 for systems presently with cartridge drive (D-31) ..... **\$5,930.00**  
MS-5051 for systems presently with fixed disk drive (D-21) ..... **\$5,930.00**

## SECOND DISK ADD-ON WITH 104 FONT LIBRARY

MS-5059 includes MS-5050 and MS-5058 ..... **\$8200.00**  
MS-5060 includes MS-5051 and MS-5058 ..... **\$8200.00**

## CARTRIDGE DISK DRIVE (D-31) REPLACEMENT FOR FIXED DRIVE (D-21)

**Includes:** Rigid cartridge disk drive, with 1 ea. cartridge, Mounting Hardware, Connecting Cables; Order MS Number below:  
MS-5061 for systems presently with 1 Fixed Disk Drive (D-21) ..... **\$4,680.00**  
MS-5062 for systems presently with Cartridge Disk Drive (D-31) operating as Drive 0 (connected directly to mainframe) ..... **\$4,680.00**  
MS-5063 for systems presently with Fixed Disk Drive (D-21) operating as Drive 0 (connected directly to mainframe) and Cartridge Disk Drive (D-31) operating as Drive 1 (terminated drive) ..... **\$4,680.00**

## GRAPHICS COMPOSE SYSTEM WITH FONT EDITOR PROGRAM

**Includes:** Digital graphics compose tablet with 16-key cursor, Graphics compose, Font Editor, and animation software, Requires TKB-3000, second disk drive, CC-1506 and CC-1507  
MS-5040 NTSC Graphics Compose with Font Editor ..... **\$8,820.00**  
MS-5041 PAL Graphics Compose with Font Editor ..... **\$8,820.00**  
MS-5040 NTSC, 525/60 RGB ..... **\$8,820.00** CC-1506/200 Cable, 200 ft ..... **\$150.00**  
MS-5041 PAL, 625/50 RGB ..... **\$8,820.00** CC-1507/50 Cable, 50 ft ..... **\$75.00**  
CC-1506/50 Cable, 50 ft ..... **\$75.00** CC-1507/100 Cable, 100 ft ..... **\$100.00**  
CC-1506/100 Cable, 100 ft ..... **\$100.00** CC-1507/200 Cable, 200 ft ..... **\$150.00**

## FONT EDITOR PROGRAM ADD-ON

For use with systems currently equipped with Graphics Compose (MS-5054 or MS-5055)  
**Includes:** 16-key cursor, Font Editor Program  
MS-5039 Font Editor Add-On ..... **\$1,850.00**

## TED ELECTION REPORTING PACKAGE ADD-ON

**Includes:** MS-5057 Digital Interface Chassis, TDC-1 Light Pen System, 8 Places for DI-500 Series Interfaces, TED Factory Training, 2 places (no travel expenses paid by Fernseh), NTSC, PAL-M or 525/60 RGB only: MS-5052 ..... **\$7,300.00**

## FONT LIBRARY DISKS

MS-5053 With 20 fonts from standard library ..... **\$1500.00**  
MS-5058 With 104 fonts in font library index TPB-3148-2 ..... **\$4500.00**  
Additional fonts at time of order ..... **\$50.00**

## FONTS ON PAPER TAPE, FROM STANDARD LIBRARY

Font XXXX (Specify four-letter font code) ..... **\$75.00 ea.**

# CHARACTER GENERATORS



## COLOR CAMERA SYSTEM

MS-5043 Color Camera System for Compositor 1, for production of 8 x 10 in. Polaroid® prints only. Requires MS-5042.  
**Includes:** Model 631 Dunn Instruments Color Camera; Polaroid 8 x 10 in. Land Film Holder; Polaroid 8 x 10 in. Land Film Processor; 1 box Polaroid Type 808 Polacolor® 2 Film ..... **\$12,890.00**  
MS-5044 Color Camera System for Compositor 1, for production of 8 x 10 in. Polaroid prints and 35mm color slides. Requires MS-5042. Includes MS-5043 and 35mm camera system. .... **\$16,890.00**  
MS-5042 RGB Video Frame, Provides RGB inputs to MS-5043/5044 color Camera System. Character edging not included (see "Accessories" below for edging information) ..... **\$3,000.00**

\*Registered trademark of Polaroid Corp

## SOFTWARE STANDARD SYSTEM WITH RIGHT TO LEFT OPERATION

OS-3001 NTSC, PAL-M or 525/60 RGB ..... **\$730.00**  
OS-3001/1 PAL-I, -G, -B, -H or 625/50 RGB ..... **\$730.00**

## SEPARATE CHANNEL/SEPARATE DISK SYSTEM

Disk 1 to CG1, Disk 2 to CG2 for separate operation 999 pages and up to 8 fonts in each channel  
MS-5033 NTSC, PAL-M or 525/60 RGB ..... **\$695.00**  
MS-5034 PAL-I, -G, -B, -H or 625/50 RGB ..... **\$695.00**

## DIGITAL INTERFACES

MS-5057 Digital Interface Chassis with Power Supply ..... **\$1,800.00**  
DI-501A RS-232C Interface, 110 to 4800 Baud ..... **\$500.00**  
DI-500A 20 MA Current Loop, 110 to 300 Baud ..... **\$500.00**

## SOLA TRANSFORMERS (SELECT ONE)

Sola 23-23-215 Regulation and transient protection transformer, 1500 VA, 60 Hz, 110/220 VAC ..... **\$600.00**  
Sola 23-25-720 Regulation and transient protection transformer, 2000 VA, 50 Hz, 110/220 VAC ..... **\$900.00**

## ACCESSORIES

EO-3000 NTSC, PAL-M, or RGB 525/60 Basic Edging (2-line border/outline, 2- or 4-line shadow, 4 luminance levels)\*\* ..... **\$1,170.00**  
EO-3000/1 PAL-I, -G, -B, -H, or RGB 625/50 Basic Edging (2-line border/outline, 2- or 4-line shadow, 4 luminance levels)\*\* ..... **\$1,230.00**  
EO-3001 NTSC, PAL-M, or RGB 525/60 Extended Edging (up to 6-line border/outline and 12-line shadow)\*\* ..... **\$1,400.00**  
EO-3001/1 PAL-I, -G, -B, -H, or RGB 625/50 Extended Edging (up to 6-line border/outline and 12-line shadow)\*\* ..... **\$1,400.00**  
CM-3002 Font memory expansion to 64K, 8 fonts max., dual system requires 2 ea. \$4300.00  
TKB-3000 Series keyboard, edit and display, specify 110 or 220 volt, requires CC-1500  
TKB-3000 English ..... **\$1000.00** TKB-3000/5, Arabic ..... **\$1200.00**  
TKB-3000/1, French ..... **\$1100.00** TKB-3000/6, Cyrillic ..... **\$1200.00**  
TKB-3000/2, German ..... **\$1100.00** TKB-3000/7 Arabic/English ..... **\$1300.00**  
TKB-3000/3, Spanish ..... **\$1100.00** TKB-3000/8, Arabic/French ..... **\$1300.00**  
TKB-3000/4, Portuguese ..... **\$1100.00**  
CC-1500/100 100 ft (30m) cable for TKB-3000 ..... **\$60.00**  
CC-1500/200 200 ft (60m) cable for TKB-3000 ..... **\$90.00**  
OP-3000 Series display control panels, display only, specify 110 or 220 volt, requires CC-1503  
OP-3000A, recess mount (4 1/2" x 10 1/2" x 3 1/2" deep) ..... **\$560.00**  
OP-3000B, rackmount ..... **\$560.00**  
CC-1503/100 100 ft (30m) cable for OP-3000 ..... **\$60.00**  
CC-1503/200 200 ft. (60m) cable for OP-3000 ..... **\$90.00**  
TSG-3000GL NTSC Broadcast Sync Generator with Genlock ..... **\$2620.00**  
TSG-2001/2 Series PAL Sync Pulse Generators with Genlock ..... Request Quote  
10-022428-001 Panel, converts OP-3000B to OP-3000A ..... **\$50.00**  
10-022433-001 Panel, converts OP-3000A to OP-3000B ..... **\$50.00**

\*\*Dual system requires 2 ea

## SPARE PARTS

CM-3032 Computer Memory ..... **\$4,000.00**  
DI-3100A Data Interface, Disk ..... **\$950.00**  
DI-3000 Data Interface ..... **\$1,013.00**  
CG-3000 Character Generator Board ..... **\$1,955.00**  
RC-3000 Roll/Crawl Board ..... **\$1,123.00**  
TC-3000 CPU ..... **\$9,500.00**  
44-023522-001 Parts Kit ..... **\$1,120.00**

## TRAINING

One place in any Compositor training class (no travel expenses paid by Fernseh) **\$450.00**

# FERNSEH INC.

the Video Corporation of  
Bell & Howell and Robert Bosch

## BROADCAST COLOR FILM CAMERA

### Features

- Prism optical system — Ghost free, precision color separation, high sensitivity, dust sealed.
- Color masking amplifier — Precise colorimetry control, camera matching, compensates for projector errors.
- Six vector color corrector — Compensates for film errors, allows selection among 3 preset and 1 manual color correction settings — optional.
- Built-in image enhancer — Full bandwidth horizontal contouring with noise coring; plug-in vertical contouring with comb filter optional.
- True film gamma correction — Reproduces 250:1 film contrast — exclusive low frequency gamma processing for optimum signal-to-noise.
- Automatic gain stabilization — White reference pulse control from pre-amp input to channel output.
- Automatic white level — Built-in fast attack N.D. wheel.
- Automatic black level — Maintains black at selected level; small area sampling circuit assures reproduction of detail near black.
- Video reversal — Permits use of economical color negative film.
- Built-in optical diplexer — Two projector inputs without external multiplexer — optional.
- Multiple input port positions — Flexible floor plan permits interface with existing film islands.
- Self-contained set-up — Monitoring and test pulse system for full set-up without external equipment; set-up performed without use of module extender; system provides direct measurement of dark current and signal current.

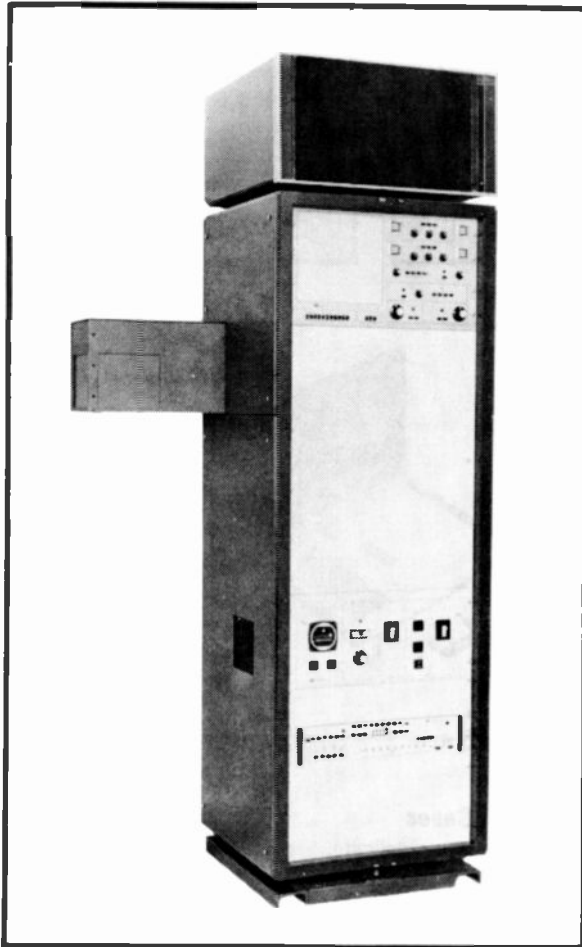

**TCF-3000**

### COLOR FILM CAMERA SYSTEM

#### BASIC TCF-3000 COLOR FILM CAMERA SYSTEM, INCLUDES:

• Horizontal deflection amplifier • Deflection waveform generator • Vertical deflection amplifier • Pulse generator • Video processor • Aperture/horizontal contours enhancer • Vertical contours enhancer • Masking amplifier • Monitor switcher • N.D. servo "A" • Bias light prism • Power supply • FL-11 Field Lens • Digital color encoder with color bar generator • CP-3000A Remote Control, less cable • Filter kit • Instruction manual

Order MS number below. Note: In addition to basic MS, all systems require 1 auto system, 1 tube set, and 1 control cable (see below).

MS-3020	TCF-3000, NTSC, 117 VAC Price includes installation in contiguous U.S.	\$49,900.00
MS-3022	TCF-3000, PAL-M, 117 VAC Installation quoted separately	49,900.00
MS-3021	TCF-3000, PAL-I, -G, -B, -H; 220 VAC Installation quoted separately	51,000.00

#### AUTO SYSTEMS (Required — Select 1)

AU-3000	Auto B Board	305.00
CA-3000	Auto Color Balance/Auto Gamma Assembly	3145.00

#### PICKUP TUBE SETS (Required — Select 1)

GE-8541	Vidicon Pickup Tubes (set of 3)	360.00
BC-4909	RCA Saticon® Tubes (set of 3) *Trademark NHK Japan Broadcasting	5115.00
XQ-1070	AmpereX Plumbicon** Tubes (set of 3) **Trademark N.V. Philips of Holland	7506.00
XQ-2070	Diode Gun Plumbicon Tubes (set of 3)	8635.00

#### REMOTE CONTROL CABLE (Required)

CC-3001-XXX	Connecting Cable for CP-3000A (XXX is length in feet)	50.00 + 1.25/ft.
-------------	---	---------------------

### ACCESSORIES

CF-3000	6-Vector Color Corrector	\$3145.00
CP-3003	Remote Control for CP-3000, mounts in RF-3002 or RF-3003 Requires CC-3003	560.00
CC-3003-XXX	Connecting Cable for CP-3003 (XXX is length in feet)	21.00 + 0.51/ft.
FL-11	Field Lens	880.00
MA-3000	Mirror Assembly for Front or Rear Light Entry	450.00
AC-3000	NTSC and PAL-M Vertical Contour Enhancer	3145.00
AC-3001	PAL-I, -G, -B, -H Vertical Contour Enhancer	3145.00
44-022 684-001	Spare Parts Kit	5025.00
RF-3002	Rack Mounting Frame — 7 in. rackmount. Holds 1 CP-3000A plus 1 BP-3002; OR, 1 CP-3000A plus 1 CP-3003 plus 1 BP-3003; OR, 2 CP-3000A's	140.00
RF-3003	Rack Mounting Frame — 10 1/2 in. rackmount. Holds 2 CP-3000A's plus 2 BP-3003's; OR, 2 CP-3000A's plus 2 CP-3003's	180.00
BP-3003	3 1/2 in. Blank Filler Panel for RF-3002 or RF-3003	30.00
BP-3002	7 in. Blank Filler Panel for RF-3002 or RF-3003	40.00
PD-2000	Pulse Delay Module for TCE-2000N/M/P Encoders	160.00
TPD-220	Transformer, converts TCF-3000 to 208/220 VAC, 50/60 Hz	285.00

### WAVEFORM MONITORS FOR TCF-3000

The TCF-3000 is designed to accept any of the following waveform monitors as an integral part of the local control panel.

1480C	Tektron x NTSC Waveform Monitor	4640.00
1481C	Tektron k PAL-1, -B, -G, -H Waveform Monitor	4825.00
1485C	Tektron x PAL/NTSC Waveform Monitor	5105.00
1482C	Tektron c PAL-M Waveform Monitor	5195.00

### VIDEO MONITORS and HOUSINGS FOR TCF-3000 For Color Monitors, See Section 12

FMM-1201	12-inch Monochrome Monitor, rackmount	615.00
FMM-1211	12-inch Monochrome Monitor, cabinet	605.00
SNA-14C	Conrac 14-inch Monochrome Monitor, cabinet	1050.00
SNA-14R	Conrac 14-inch Monochrome Monitor, rackmount	1040.00
DZB-15RS	Conrac 14-inch Broadcast Quality Monochrome Monitor, Rackmount	1760.00
MH-3000	Rotating Monitor Housing, provides 10 1/2 in. rackmount space for FMM-1201, Conrac DZB-15RS, SNA-14RS, or MC-37 monitor	495.00
MH-3001	Rotating Monitor Tray, accepts FMM-1211, SNA-14C, or MC-37 monitor	125.00

### CONSOLE and ACCESSORIES FOR TCF-3000

TER-1800/1	Equipment Console. Specify 10.5, 14, 17.5, or 21-inch writing arm	980.00
VU-100	VU Meter, 5.25 x 9.5 inch	165.00
SA-100	Speaker Assembly	100.00

### PROJECTORS and LENSES

S-32	Spindler-Sauppe Spectrum 32 x 2 in. Slide Projector, 115 VAC, 50/60 Hz, with lens**	9500.00
P-32	Spindler-Sauppe Producer 32 x 2 in. Programmable Slide Projector, with remote control, 5 ft. cable and lens**	13900.00

\*\* Specify one of the following:

PL-290 7.5 in. (190mm) f/4.0 lens for S-32, P-32		
PL-295 9.0 in. (225mm) f/5.0 lens for S-32, P-32		
A-4000	Athena 4000-TSM MK IV 16mm Film Projector with 4,000 ft. capacity, 115 VAC, 60 Hz, 1, 2, 4, 6, 12, 24 fps. Requires FE-510 and FE-511 (see "Projector Stands" below). Less lens	8450.00
A-6000	Athena 6000 16mm Film Projector, multi-voltage, multi-frequency, 1, 2, 4, 8, 12, 24 fps.	20,150.00
	5000 ft. capacity. With pedestal, less lens*	
	* Specify one of the following:	
75mm f/4.5 Schneider lens to A-4000, A-6000		325.00
80mm f/5.6 Schneider lens for A-4000, A-6000		395.00

# Fiberbilt

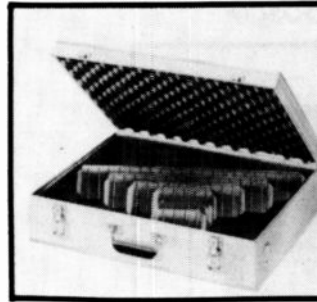
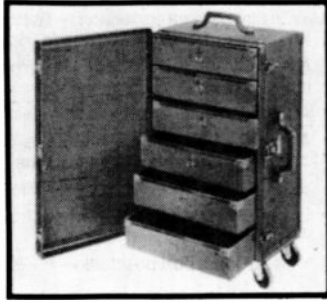
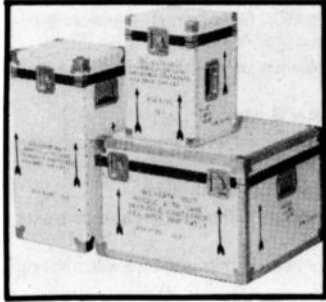

## EQUIPMENT CASES

### Padded Adjustable Cases

Quick, easy, do-it-yourself partitioning methods to fit your particular needs for carrying or shipping cases.

### Padded Partitions

A patented system of thickly padded partitions interlock with each other and with the padded sidewalls of the case by means of the tongue-and-groove principle. Slots spaced 1" apart in the padding of the partitions and sidewalls provide for any compartment arrangement to cushion your equipment perfectly with shock absorbing foam padding. The partitions can be rearranged or added to at any time and the case is fully insulated against heat, cold and dust.

### Diced Foam

Diced foam full depth padding "picks out" to provide any shape or size cavity for the ultimate in equipment protection.

An ingenious and very practical new Adapt-A-Case concept lets you "pick out" the contour areas you need from the one-inch thick layers of grid pattern, partially-cut-through foam. The Adapt-A-Case way to provide snug-fit protection for the most delicate equipment.

### Sales Aid Cases

Fiberbilt's design and manufacturing expertise can help you achieve the perfect case to display and protect your product so that it remains in tip top condition.

Our stock cases are designed to display specific products to maximum advantage. Our individually designed cases can do the same job for your product no matter what it is.

Just send us your samples, and we will submit a sketch or layout without charge. Cost estimates also submitted on any quantity — whether a single case or thousands. Whatever the product, we have the experience to custom design a case to your exact specifications.

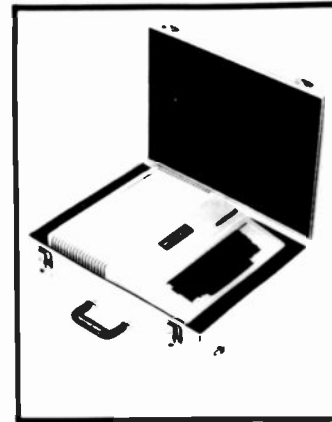

### Protective Carrying Cases

Your product, no matter how delicate, is protected by these strong, attractive, and lightweight carrying cases.

Our stock styles can be obtained with either specially die-cut foam inserts and partitions, or with our patented adjustable partitions.

Special cases in any style or size can be manufactured and customized to your specific needs . . . economically, even in small quantities.

### Protective Shipping Cases

Your product is protected when shipped by land, sea, or air in one of Fiberbilt's many distinctive and protective shipping cases...rugged, durable, lightweight.

Pick your exterior: Aluminum, Fiberglass, or Fibre bonded to plywood — to give a lightweight, yet tremendously rigid and durable shell. Or, for lower weight and cost, choose a high density polyethylene case. No matter which you select, you've got a rugged exterior designed for heavy cameras, TV monitors and other delicate equipment that you want to travel safely.

Inside choose special padding, contoured foam, partitions or trays, designed by our engineers to cushion your equipment to take the roughest knocks.

### Computer Hardware Cases

Fiberbilt manufactures a complete line of cases for shipping and carrying computer equipment. Call for details on a case for your particular piece of equipment.





## VIDEO TYPEWRITERS

### VTW-200

#### Features:

- Types both upper and lower case characters
- Professional 7 x 9 dot matrix display format
- Up to 32 characters x 8 lines per page, with total of 4 pages
- Eye catching flicker mode
- Line printer and other options available

The VTW-200 provides an easily operated and reliable means to superimpose types information onto the picture in a television system. By simply operating the keyboard, which resembles that of a familiar electric typewriter, desired information becomes typed into the television scene.

Both upper and lower case alphabetical characters can be typed, while display is an attractive 7 x 9 dot matrix. Up to 8 lines of 32 characters each can be displayed per page and a total of 4 pages is provided.



Horizontal size of characters is variable for each line and an eye catching flicker mode can be used to cause an entire line to flicker during display ..... \$1535.00

### VTW-320

#### Features:

- Advanced version video typewriter
- Built-in 4 page memory (expandable up to 8 pages)
- Professional 7 x 9 dot matrix character format
- Two step rollup functions
- Optional line printer available

The VTW-320 is an advanced version Video Typewriter developed in response to demands for increased sophistication and expanded functions. A 4-page memory (expandable to 8-pages) is incorporated which allows pretyped data to be instantly switched in and out of the picture, in addition to real-time display of data as it is being typed.

Appearance of the alphanumeric and typographical symbols is more attractive and professional by employing a 7 x 9 dot matrix character format. Up to 8 lines can be displayed at one time (internally switchable to 15 lines) with front panel selection of 16 or 32 character units per line.

Two step rollup functions are included, increasing the flexibility for program and video tape production. An optional line printer is also available to provide paper type-out for convenient indexing and filing.

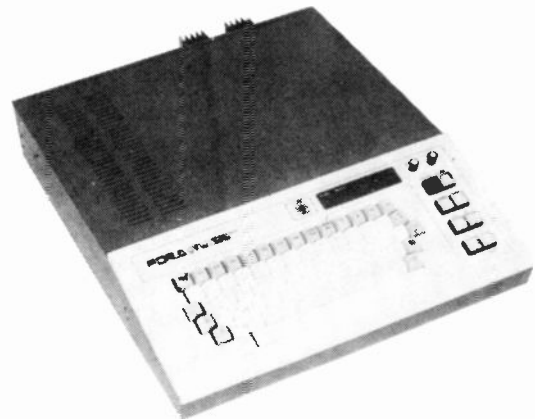

Connection of the VTW-320 into new or existing television systems is performed by simple bridge-through connection with ordinary coaxial cable. .... \$2145.00

### VTW-500

#### Features:

- Superimposes typed information in both line and preview monitors
- Includes 4 display modes — normal, roll, crawl and wipe
- Built-in 8-page memory
- Switchable edged characters
- Sequential change of selected page automatically or manually
- Professional 7 x 9 dot matrix display format in the preview monitor and professional 16 display format in the line monitor

This advance version of the VTW-500 has been developed to provide broadcasting quality. It can superimpose typed information onto either blank or picture backgrounds in the line and preview monitors, simultaneously or separately. New information can be typed into the preview monitor while programmed information is displayed in the line monitor. Various expanded functions, such as normal, roll, crawl, wipe modes, line quantity control, mode start-time control, flickering, vertical position setting, page-to-page line jumping, matting control, automatic/manual operation, and sequential change of selected page, are all included in the system with easy operation.

Each page of the built-in 8-page memory can contain a maximum of 16 lines of 32 characters (professional 7 x 9 dot matrix character) in the preview monitor and 12 lines of 32 characters (professional 16 by 21 dot matrix character) in the line monitor. For better legibility, each alphanumeric character has an edge (black outline around character) which is switched on/off by the matting control. Character



size function allows each character to change its size horizontally or vertically. Up to 128 characters are available for use in the keyboard layout by using the first and second shift keys. .... \$6140.00

Prices and specifications subject to change without notice

# FORTEL



## VIDEO TIME BASE CORRECTOR

### ccd-1h

- Signal-to-Noise: 60db NTSC  
58db PAL
- Differential Phase — 1%
- Differential Gain — 2%
- Window of Correction — 1H
- Affordable Price
- NTSC or PAL

The ccd-1h is ideal for all heterodyne VTR users, including educational, industrial, cable TV, hotel and motel movie channels, and broadcasters where in their editing stations they will be able to remove the multi-generation error build-up.

The ccd-1h Video Time Base Corrector offers high quality and simplicity in operations at a very economical price. We are using the latest technology in charge-couple-device memory which enables us to remove skew and jitter distortions from your picture at a reasonable price.

The ccd-1h has a correction window of one horizontal line (1H) with a floating window that tracks the recorder. By tracking the recorder we can remove your multi-line errors and a special anti-break-up circuit ensures the window will always track at the right rate. It tracks slowly with good tapes removing even low frequency error. The rate of tracking gradually changes as errors increase and become abrupt at the edges of the window so the skew can still be removed on very poor quality tapes.

The ccd-1h strips off your old sync, cleans it up and reinserts new sync and burst with proper rise and fall times. Interlace and non interlace sync are processed automatically.

Color and monochrome selection is also automatically determined by the ccd-1h.

The ccd-1h has an automatic bypass relay which is energized when the power on switch is in the off position. It is also automatically energized in the event of a power failure. On the front panel, the Video Gain Control has a range of +/- 40%. The Set-Up Control has a range of +/- 15 IRE. The Chroma Gain Control has a range of +/- 40%. The range of the Hue Control is +/- 30°.

### ccd-2h

- Noise Reduction up to 10db
- Image Enhancement
- Gen-Lock Sync Generator
- Affordable Price

The ccd-2h is ideal for all heterodyne VTR studios. With noise reduction, image enhancement, system gen-lock and a window of correction of two horizontal lines (2H), no application is too demanding. We are using the latest technology in charge-couple-device analog memory. We have also made needed features standard rather than options. This gives you high performance at a very competitive price.

### PROCESSING AMPLIFIER ccd 2h-1

New sync, burst, and blanking are added to the processed video. Advanced servo-controlled sync and phased subcarrier are available to drive your VTR. A white and a black clipper are standard.

### SYNC GENERATOR ccd 2h-2

The color gen-lock sync generator meets RS-170A standards and has an oven-controlled crystal oscillator. The blanking widths on your processed video are adjustable. Sync and subcarrier timing are adjustable, enabling you to easily phase your studio.

### NOISE REDUCTION ccd 2h-3

The ccd-2h can reduce your chrominance noise up to 10 db and reduce the luminance noise up to 7 db. By using a combination of combing and coring, we can improve your signal-to-noise ratio greatly without causing any picture smear.

### IMAGE ENHANCEMENT ccd 2h-4

The ccd-2h uses both horizontal and vertical enhancement to give a well-defined, sharp picture. We core the enhancement frequencies before we add them back to the luminance. This gives a sharp picture without causing additional noise normally associated with enhancement.

ccd1h	NTSC Time Base Corrector	..... \$	3,950.00
ccd-1h PAL	PAL Time Base Corrector	.....	4,200.00
ccd2h-1	NTSC Time Base Corrector	.....	6,250.00
ccd2h-1 PAL	PAL Time Base Corrector	.....	6,650.00
ccd2h-2	NTSC Time Base Corrector	.....	7,950.00
ccd2h-2 PAL	PAL Time Base Corrector	.....	8,450.00
ccd2h-3	NTSC Time Base Corrector	.....	8,250.00
ccd2h-3 PAL	PAL Time Base Corrector	.....	8,750.00
ccd2h-4	NTSC Time Base Corrector	.....	9,950.00
ccd2h-4 PAL	PAL Time Base Corrector	.....	10,550.00



**G K C RESEARCH & DEVELOPMENT**

## AUDIO DEVICES



**Model MA4**  
Universal Micro Mixer  
(compatible with all Mini-Cam recorders)

**Universal Micro Mixer**  
**Model MA4**  
Compatible with all Mini-Cam recorders  
\$475.00

All integrated circuits, low noise, wide flat frequency response.  
• Four low impedance balanced microphone inputs female XLR-3-31  
• High level line input • Microphone level output (adjustable through an internal control) • 600 ohms balanced line output at 0 level • Monitor headphone jack • Standard  $\frac{1}{4}$ " VU meter • Derives power from enclosed standard 9 V. alkaline battery • External power input jack for battery or well filtered DC power supply up to 12 V. • All connectors are American standard • Die cast aluminum body with black-texture finish • Dimensions: 5-1/4"W x 4-3/4"H x 2-3/8"D, Weight: 1-1/2 lbs.

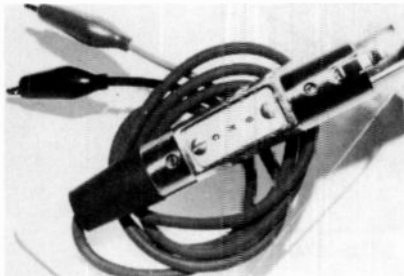

**Model 200**  
Tele-Coup Phantom  
Powered Microphone Amplifier

**Phantom Powered Microphone Amplifier**  
**Tele-Coup (Model 200)**  
\$69.50

For use in telephone systems. The entire Amp. is constructed inside the Switchcraft T3F connector. By inserting it into any professional microphone whether of the dynamic or the condenser type having a 200 ohms impedance and a sensitivity of 100 microvolt, and connecting the other side of cable with the alligator clips to the telephone transmitter contacts, directly replaces the carbon microphone.

**Monitor Amplifier Speaker**  
**Model 700**  
\$99.50

All integrated circuit amplifier, primarily designed for ENG applications and it has many other uses in the broadcast industry. It can be used as a speaker amplifier, speaker headphone amplifier, or strictly as a headphone monitor amplifier. It comes with a belt clip, 9 V. battery and leatherette pouch. • Input 1 K ohms • Output 8 ohms • Dimensions: 4-1/4"H x 2-1/4"W x 1-1/4"D.

**Headphone Monitor Amplifier**  
**Model 500**  
\$69.50

A high quality all integrated circuit amplifier, widely used by broadcast engineers on remotes and motion picture sound men on location, it features two output phone jacks and a belt clip for the convenience of the operator. It comes with battery and leatherette pouch. • Input 1 K ohms • Output 8 ohms • Power output 350 mW • Power requirement: 9 V. battery • Dimensions: 4-1/4"H x 2-1/4"W x 1-1/4" D. Also available in 600 ohms output — Model 500H.

**Model 500**  
Headphone  
Monitor  
Amplifier



**Model 700**  
Monitor  
Amplifier  
Speaker



**Mic-Line Amplifier**  
**Model 100**  
\$119.50

This amplifier is designed for the broadcast engineer who desires versatility, compactness and reliability. Ideal for use with long cables from mic to mixer, from mic to telephone line or from mic to microwave system. An internal Helipot is provided to adjust mic pre-amp output to any desired level. It comes with belt clip, battery and leatherette pouch. • Low impedance mic input female XLR • 600 ohms balanced line output • Power requirement: 9 V. battery • Dimensions: 4-1/4"H x 2-1/4"W x 1-1/4" D.



**Model 100 Mic-Line Amplifier**  
Prices and Specifications Subject to Change Without Notice.



MTS-3000

## COMPUTERIZED INTERACTIVE TELEVISION SYSTEMS

By combining the technologies of computers with television, you now have the ability to enhance learning to an extent never before possible. CIT (Computerized Interactive Television) offers:

- Active learner involvement and participation
- Individualized instruction
- Incremental learning
- Repetition and review
- Reinforcement and motivation
- Assessment of student learning
- Storage of retrieval of assessments

GenTech provides everything necessary to help you make CIT reach its full potential!

In addition to sophisticated state-of-the-art CIT hardware, only GenTech offers expertise in all areas necessary to make CIT work for you:

- Research of communications problems
- Definition of learning objectives
- Instructional design
- Concept and video script development
- TV production and editing
- Software programming
- Computer course authoring
- Video meetings
- Supplemental media production
- Engineering back-up and maintenance
- Special hardware design and manufacturing

### ETS-2000 Interactive Television System

The ETS-2000 Video Controller enables a microcomputer to precisely control a video player, allowing the interlacing of educational television segments with computer assisted instruction and testing modules. Components include interface card, connecting cables, operator's manual and diskette containing operation and demonstration software.

### ETS-2000 Authoring System, 2.0

This software system, on diskette, makes the authoring of complicated CIT programs easy and fun, even for people without computer programming experience. Features include a question-answer format of authoring, menu-oriented selections, multiple review modes and response options. Package includes diskette and instruction manual.

### ETS-2000 Videotape Logging System

A software system anyone can use to automatically, quickly and accurately locate any scene on a video tape. Use the ETS-2000 Interactive Controller, microcomputer and video player to solve costly, time-wasting searches for specific scenes. Components include the diskette and instruction manual.

### MTS-3000 MultiTerm System

This system allows the expansion of the ETS-2000 system from a one-on-one mode to a classroom or similar mode in which up to 128 individuals may interact simultaneously. The system can be used with or without television for group interaction with live lecture or demonstration...to instruct, test, perform, research, develop marketing and management data, and many other functions.

### MultiTerm Starter Package

With MultiResponse Card, MultiLink Unit, 8 MultiTerms (response units), MultiTerm Handler Software Package, Instruction Manual, 50' Cable.

### MultiTerm Expansion Package

(up to 15 of these may be used for a maximum system capacity of 128 MultiTerms); with MultiLink Unit, 8 MultiTerms (response units) with 10' Cable.

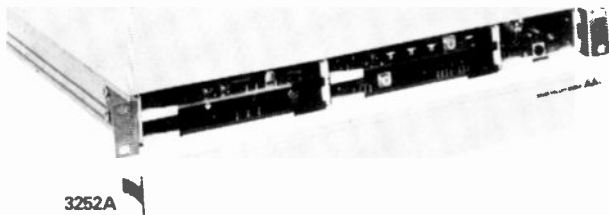

3252A



3256A



3260

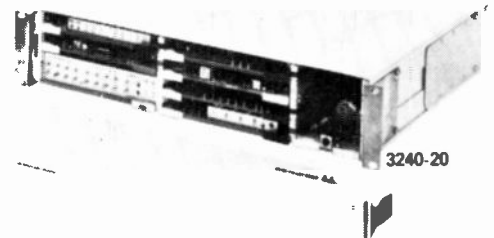

3240-20



## VIDEO PROCESSING SYSTEMS

### 3252A Series Sync Generator Systems

**3252A-SG1 Dual Sync System** consisting of two 3252A Sync Generators with power supplies and Pulse DA-1, 3257A Changeover with power supply, module extender, remote connectors and two instruction manuals. **\$9350.00**

**3252A-SG2 Dual Sync System** consisting of two 3252A Sync Generators with power supplies and Pulse DA-2, 3257A Changeover with power supply, module extender, remote connectors and two instruction manuals. **\$8450.00**

**3252A Single Sync Generator**, power supply, module extender, remote control and two instruction manuals. **Note:** Either Option -201 or Option -202 is required for operation. **\$3250.00**

**Option 3256-201** Pulse output DA-1 (6 pulse outputs which are gaussian corrected plus/or two test outputs with eight selectable test patterns). **\$ 850.00**

**Option 3256-202** Pulse output DA-2 module (6 pulse outputs, ramp-shaped, plus two color black outputs). **\$ 400.00**

### 3256A Series Sync Generator

**3256A Slave Sync Generator** without Pulse Distribution Amplifier (Option-201 or -202 must be ordered), power supply, module extender and two instruction manuals. **\$1850.00**

**Option 3256-201** Pulse output DA-1 (6 pulse outputs which are gaussian corrected plus two test outputs with eight selectable test patterns). **\$ 850.00**

**Option 3256-202** Pulse output DA-2 Module (6 pulse outputs, ramp-shaped, plus two color black outputs). **\$ 400.00**

**Option 3256-213** Encoded Subcarrier Module (converts Slave to Master Sync Generator). **\$250.00**

### 3260 Series Sync Generator Systems

**3260-SG1 Dual Sync System** consisting of two 3260 Sync Generators with power supplies and Pulse DA-1, 3257A Changeover with power supply, module extender, remote connectors and two instruction manuals. **\$9100.00**

**3260-SG2 Dual Sync System** consisting of two 3260 Sync Generators with power supplies and Pulse DA-2, 3257A Changeover with power supply, module extender, remote control connectors and two instruction manuals. **\$8200.00**

**3260 Single Sync Generator** with power supply, module extender, remote connector and two instruction manuals. **Note:** either Option -201 or Option-202 is required for operation. **\$3150.00**

### 3257A Automatic Changeover Switch

**3257A Automatic Changeover Switch** is an automatic transfer device for use with synchronizing generators. Switching can be initiated either in a manual or an automatic basis.

The 3257A contains eight detectors which provide sensing for eight of the nine output lines. All detectors are adjustable to operate with either 2 volt or 4 volt pulses and 1 volt or 2 volt subcarrier signals. One detector has increased gain to permit sensing of a low-level, steady state signal such as color black or encoded pulse reference.

The switch is applicable to all types of synchronizing generators as well as all television standards — NTSC, PAL, PAL-M and SECAM. **\$1500.00**

### 3240 Series Video Processing Systems

3240-10

**3240-10 Basic Video Processing System** The basic 3240-10 system is a fully functional processing amplifier, available in one rack unit (RU=1.75") height. Controls are available on the card edge or at a remote control point. The compact and rugged construction, coupled with low power consumption and wide supply voltage range, make it ideal for remote van applications. All active components are accessible from the front of the plug-in modules. Conservative rating, and a sealed air design that keeps contamination out, will assure years of trouble free service. MTBF is projected to 20,000 hours, or about four years of normal service.

The 3240-10 System comprises: (1) 06637 Video input module • (1) 066341 Sync generator module • (1) 066339 Color lock module • (1) 061057 Power supply • (1) Mounting tray (1- $\frac{3}{4}$  x 19" rack mount) • (1) Module extender • (2) Instruction manuals. **Note:** The basic system above does not allow for fitting of all optional items. Some options require the 3240-20 system listed below. **\$4000.00**

**3240-20 Basic Video Processing System** The expandable 3240-20 system in the two-RU frame contains four additional cells for accessories. The accessories are plug-in modules that complement the basic processor. The frame has been prewired to accept the accessories, and power is supplied from the 3200A Power Supply. Current accessories are available and future options will be designed to fit the existing two-RU frame.

The 3240-20 system comprises: (1) 066337 Video input module • (1) 066341 Sync generator module • (1) 066339 Color lock module • (1) 066338 Video output module • (1) 061057 Power supply • (1) Mounting tray (3- $\frac{1}{2}$  x 19" rack mount) • (1) Module extender • (2) Instruction manuals. **Note:** 3240-20 systems may be used with all the basic options available for the video processing systems. **\$4200.00**



GRUBER PRODUCTS CO.

## FOLDING SLIMLINE ON-LOCATION SERIES

The **ENG-1** mobile camera cart was developed for the video industry as the ideal vehicle for transporting and employing portable video recording equipment. The unit accommodates most VTR and camera CCU's as well as the AC adapters and battery packs. Addition of the elevator column and friction, cam or fluid head converts the **ENG-1** into the most versatile production tool available. **ENG-1** folds to a slim 12 inches for transportation and storage.

### Wheelit Indoor/Outdoor Slim Line Folding Video Cassette Table, 4118:

Designed for indoor/outdoor transportation of video recorder and monitor **Model 4118** Wheelit Slim Line pivots to collapse to an incredibly thin 12 inch profile. In the trunk of your automobile or stored in a closet, there is room to spare. Platforms lock into the upright position with positive assurance.



#### Model ENG-1 ..... \$250.00

Equipment Platform ..... 14" x 29"  
 Camera platform pre-drilled to accept Quick-Set 7900 elevator column ..... 5 3/4" x 14"  
 Wheel base ..... 16"  
 Shipping weight ..... 50 lbs.

ACCESSORIES ... Receptacle and cord reel.  
 Elevator column. Friction, fluid or cam heads.

#### Quick-Set Accessories:

79000-2 Elevator Column ..... \$190.00  
 72013-2 Friction head ..... 160.00  
 72300-3 Cam link head ..... 375.00

#### Model 4118 ..... \$195.00



Platforms ..... 18" x 24"  
 Top Platform to floor ..... 41 1/4"  
 Bottom Platform to floor ..... 30 1/4"  
 Load Capacity ..... 120 lbs.  
 Wheels ..... 12"  
 Casters ..... 4 in w/swivel & lock  
 Wheel base ..... 16"  
 Shipping Weight ..... 51 lbs.

MODEL ENG-1



MODEL 4118

## FOLDING ACTION SERIES

The folding Wheelit **model C-402** is an all purpose utility vehicle designed for transportation of video tape equipment, audio-visual equipment, photography equipment, and business machines.

Construction of Wheelits **68-402P** and **69-22-VTR** is similar, however, basic differences will be found in the length of the wheel bases and the dimensions of the platforms.



#### MODEL C-402: \$210.00

Upper Platform 21" x 16" 40" height  
 Lower Platform 21" x 12" 18" height  
 Caster Platform 19" x 6"  
 Load Capacity 150 lbs.  
 Wheel Base 16"  
 Wheels 12"  
 Casters 4" w/Swivel & Lock  
 Shipping Weight 56 lbs.



#### MODEL C-402

#### Model 68-402-P Video Tape 1/2 Inch . \$226.00

Upper Platform 21" x 16" 40" height  
 Lower Platform 21" x 15" 18" height  
 Load Capacity 175 lbs.  
 Wheel Base 19"  
 Wheels 12"  
 Casters 5" Swivel  
 Shipping Weight 65 lbs.



#### MODEL 68-402-P

#### Model 69-22-VTR Video Tape 1 Inch \$237.00

Upper Platform 24" x 15" 40" height  
 Lower Platform 24" x 18" 14 1/4" height  
 Load Capacity 175 lbs.  
 Wheel Base 22"  
 Wheels 12"  
 Casters 5" w/Swivel & Lock  
 Shipping Weight 70 lbs.



#### MODEL 69-22-VTR

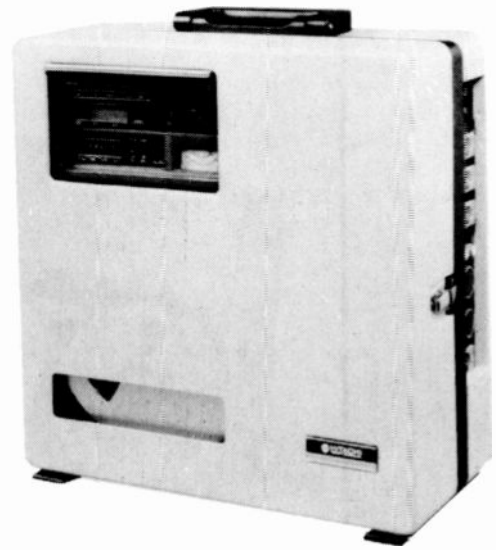

## 1" VIDEO TAPE RECORDER

### HR-100 PORTABLE 1-INCH HELICAL VTR

The Hitachi HR-100 is a portable video tape recorder designed in accordance with the SMPTE Type C Standard. In addition to tape interchangeability with the table model HR-200, the HR-100 offers interchangeability with other 1-inch, C-standard helical video tape recorders. While it is simple to operate, the HR-100 delivers all the required functions for professional use. Its small size, light weight and rugged construction provide excellent reliability, and it is ideal for ENG and EFP application.

- **A Portable VTR, Meeting SMPTE Type C Standard**  
The HR-100 is completely interchangeable with the table model HR-200. Tapes recorded by the HR-100 can be reproduced by other 1-inch C-standard tape recorders.
- **Small in Size, Light in Weight**  
The tape transport of uniblock construction, the housing of one-piece construction and printed circuit board holder combine to make the HR-100 sturdy, small in size, and light in weight.
- **Low Power Consumption**  
Switching-type motor drive amplifiers for the drum, capstan and reels are provided for improved efficiency. In addition, switching regulators and the extensive use of C-MOS ICs help to reduce power consumption.
- **Excellent Environmental Characteristics**
  - a) No parts except the heads contact the magnetic surface of the tape—sharply reducing the possibility of dropouts.
  - b) Small overall wrap angle in the tape path for smooth tape movements.
  - c) A digital servo circuit which is resistant to temperature and aging.
  - d) An FM modulator with an AFC circuit.

- **Automatic Assemble-Edit Function**

The HR-100 has a built-in automatic assemble-edit function which automatically rewinds the tape at the end of recording, and gives it a correct backspace. This feature permits complete assemble-editing merely by repeated REC button operation at the camera.

- **60-Minute Operation from Built-in Battery**

The HR-100 can operate on a nickel cadmium battery (12V, 6AH) for over 60 minutes. Battery operation allows for complete mobility in field production. The HR-100 also operates on an external DC power supply.

- **Video Confidence**

Video signals can be simultaneously monitored during recording so that you can ascertain that you are acutely recording the signals you want.

- **Built-in Time Code Generator**

Built-in SMPTE time code generator permits to record hours, minutes, seconds and the number of frames established previously.

**HR-100. Portable Model Type "C" Recorder.** Portable Battery operated Recorder conforms to all SMPTE Type "C" standards. Features Video Confidence Head, Sync Head, Built-in Time Code Generator, Back Space Editor and Digital Servo System. . . . \$34,500

**Including:** Take-up Reel, Operation/Service Manuals, Set of Extender Cards.

**Accessories:**

AP-10 AC Adaptor . . . . .	\$500.00
BT-10 1 Hour Plug-in Battery . . . . .	500.00
BU-10 Battery Unit (1 or 2 Batteries additional) . . . . .	1200.00
BC-10 1 Hour Quick Charger . . . . .	500.00
BC-10/2 1 Hour Dual Quick Charger . . . . .	850.00
CP-11 Color Playback Stabilizer . . . . .	2300.00
RB-10 Remote Control Unit With Combination Jog/Shuttle LED Display, Edit Controls, Standby and Power Switch	500.00
WC-10 Winter Heating Cover . . . . .	490.00
CL-10 Carrying Case . . . . .	317.00
VH-10 Spare Video Head Assemble . . . . .	900.00
SPK-10 Spare Parts Kit . . . . .	1150.00
AL-21 Alignment Tape . . . . .	500.00
HH-21 Video Head Chip Height . . . . .	360.00
SVM-HR-100 Service Manual (Spare) . . . . .	60.00
SVM-TC-200B Service Manual (Spare) . . . . .	60.00



HR-200B

HR-200B Studio System

**HR-200B  
1-Inch Helical VTR**

- High-performance conforming to broadcast standards
- In accordance with the SMPTE Type C Standard
- Rugged construction and excellent reliability
- Ease of maintenance and service

The HR-200B design concept makes it superior professional video tape recorder which features greater durability and easy operation.

The HR-200B provides the economy of helical scan, the editing ease of film and the advantages of quadruplex.

**Features**

- Picture quality of broadcast standards: High-quality high band recording and reproducing systems are featured.
- Tape interchangeability: The HR-200B is completely interchangeable with 1-inch helical video tape recorders which meet the SMPTE Type C Standard.
- Rugged construction and greater reliability: The precision-cast tape transport and control block are rugged, accurate and simple in construction. Consequently, the HR-200B is highly reliable and capable of withstanding rough operating conditions.
- Improved operation with non-contact drum: since there is no contact between the video head and the tape during standby, fast forward and rewind, the lives of the heads and the tape are extended and many other operational advantages are involved.
- Minimum dropouts: All parts along the tape path, except the heads, do not contact with the magnetic surface of the tape. As a result, the possibility of dropouts is reduced to a minimum.
- Easy tape loading by movable guide: An important condition to realize easy tape loading in Type C video tape recorders is acquired by the adoption of a movable guidepost.
- Steady tape travel by air tape guide: The air tape guides at tape entrance and exit assure steady tape travel in spite of humidity and other environmental variations. Additionally, the time necessary to get 50X-speed is reduced in shuttle mode.
- DC motors with excellent response: The drum, capstan, reels, etc. are all driven by DC motors, which combine with the air-guide effect to assure high efficiency and quick start. In the shuttle mode, the tape reaches 50 times the normal speed within only 10 seconds.

- Front-access circuit boards: Most of the circuit boards can be accessed from the front for easy maintenance and adjustments. The controls which require no daily adjustment are mounted on the circuit boards. This makes a main control panel very simple.

- Easy replacement of heads: The video heads can be replaced together with the upper drum without need for adjustments and soldering.

- Video and audio confidence: Video and audio signals can be simultaneously monitored during recording so that you can ascertain that you are actually recording the signals you want. Also, optimum recording current and bias current can easily be set.

- Various controls by built-in microcomputer: Tape timer function, electronic editing function, automatic tape drive to starting position, etc. are processed by the built-in microcomputer for maximum ease of operation. In addition, the automatic editing functions can easily be expanded by the addition of an external editing console.

**HR-200B** Studio Model Recorder/Reproducer  
 Conforms to SMPTE Type "C" Standards  
 Includes Standard Video and Audio Confidence Heads, "Pro" Tape Path, Jog/Shuttle Control, Less Monitoring  
**\$44,200.00**

**TC-200B** Optional Accessories  
 Digital Time Base Corrector  
 Features 10H window, Dropout Compensation, Velocity Error Corrector, Service Manuals, Extender Cards  
**\$18,900.00**

**TR-20** Time Code Reader **\$1,450.00**

**TG-20** **990.00**

**CP-20** Color Playback Stabilizer **2700.00**

**RB-20** Remote Control Unit with Combination Jog/Shuttle, LED Display, Edit Control, Standby and Power Switch **4850.00**

**HR-200B Studio Systems**

**HR-200B1** Studio System-1 Studio Model Recorder/Reproducer Conforms to SMPTE Type "C" Standards; Excludes Console and SL-20. Standard Features Include Video and Audio Confidence Heads, "Pro" Tape Path, Jog/Shuttle Control, Less Monitors  
**\$63,100.00**  
 Includes  
 HR-200B.....Transport  
 TC-200B.....Digital TBC  
 Take-up Reel and Set of Extender Cards  
 Operations/Service Manual

**HR-200B2** Studio System-2 Studio Model Recorder/Reproducer Conforms to SMPTE Type "C" Standards Excludes Console. Standard features are Video and Audio Confidence Heads, "Pro" Tape Path, Slow Motion, Jog/Shuttle Control, Less Monitors.  
**\$70,600.00**

Includes  
 HR-200B.....Transport  
 TC-200B.....Digital TBC  
 SL-20.....Slow Motion  
 Take-up Reel and Set of Extender Cards  
 Operations/Service Manual

**HR-200B3** Studio Console System-3 Studio Console System Model Recorder/Reproducer Conforms to SMPTE Type "C" Standards Includes Standard Console Excludes SL-20  
**\$69,500.00**

Includes  
 HR-200B.....Transport  
 TC-200B.....Digital TBC  
 CN-200B.....Studio Console  
 Take-up Reel  
 Operations/Service Manual

**HR-200B4** Studio Console System-4 Studio Console System Model Recorder/Reproducer Conforms to SMPTE Type "C" Standards Includes Standard Console, Video and Audio Confidence Heads, "Pro" Tape Path, Slow Motion, Jog/Shuttle Control and Monitoring Bridge, Less Monitors  
**\$77,000.00**

Includes  
 HR-200B.....Transport  
 TC-200B.....Digital TBC  
 CN-200B.....Studio Console  
 SL-20.....Slow Motion  
 Take-up Reel  
 Operations/Service Manual



**HR-210 1-INCH HELICAL VTR**

Broadcast 1" VTR designed for mastering and post production houses and high-end industrial applications

**Features**

- Retracting entrance guide system greatly reduces tape loading difficulties
- Air support tape guide system prevents the tape from contact with the heads
- No-contact head drum extends the usable life of tape and heads, effectively preventing head clogging
- "PRO" tape path serves to reduce tape dropouts ("PRO" Protective Reverse Oxide)
- Adjustment-free head replacement no need for any special gauges, soldering or adjustments
- Optional HST (Head Scan Tracking) system for variable speed playback from 1/4 to 1-1/2X play speed.
- Both video and audio confidence
- Protection cover for tape transport
- Built-in cable compensator
- Optional dual tape timer
- Accurate and easy-to-operate editing system
  - Color framing
  - Cue shift
  - Split edit
  - Insert/assemble editing
- Autochroma standard
- Deviation marker for accurate and easy modulation setting
- Built-in color processor (option)
- Common head for PB/REC
- Video sync heads standard
- Audio spot erase
- Optional 4th audio track (EBU Type "C")
- Fully servo-controlled tape tension system with direct drive DC reel motors
- Reel brake release button (foot switch is option)
- Tape speed override for editing or network delay sync
- Spot reel capability with no switch operation
- Remote control of TBC (TC-200B) on the VTR operation panel
- Shuttle/Jog combination knob
- Tape transport light to make tape threading made easier in a darkened room
- Front access circuit modules for easy maintenance and adjustment
- Rugged tape transport of a precision aluminum alloy casting

**HR-210** **\$80,400.00**

Hitachi Production Console (HPC) System. Studio Console System Model Recorder/Reproducer Conforms to SMPTE Type "C" Standards. Standard Features are Slow Motion, Video and Audio confidence, Edit Frame Shift, Full TBC Controls on Console, Three Selectable Remote Control Parts and Monitoring Bridge, Less Monitors

Includes:

HR-200B .....	Transport
TC-200B .....	Digital TBC
CN-210 .....	Production Console
SL-20 .....	Slow Motion

Take-up Reel and Set of Extender Cards Operations/Service Manual

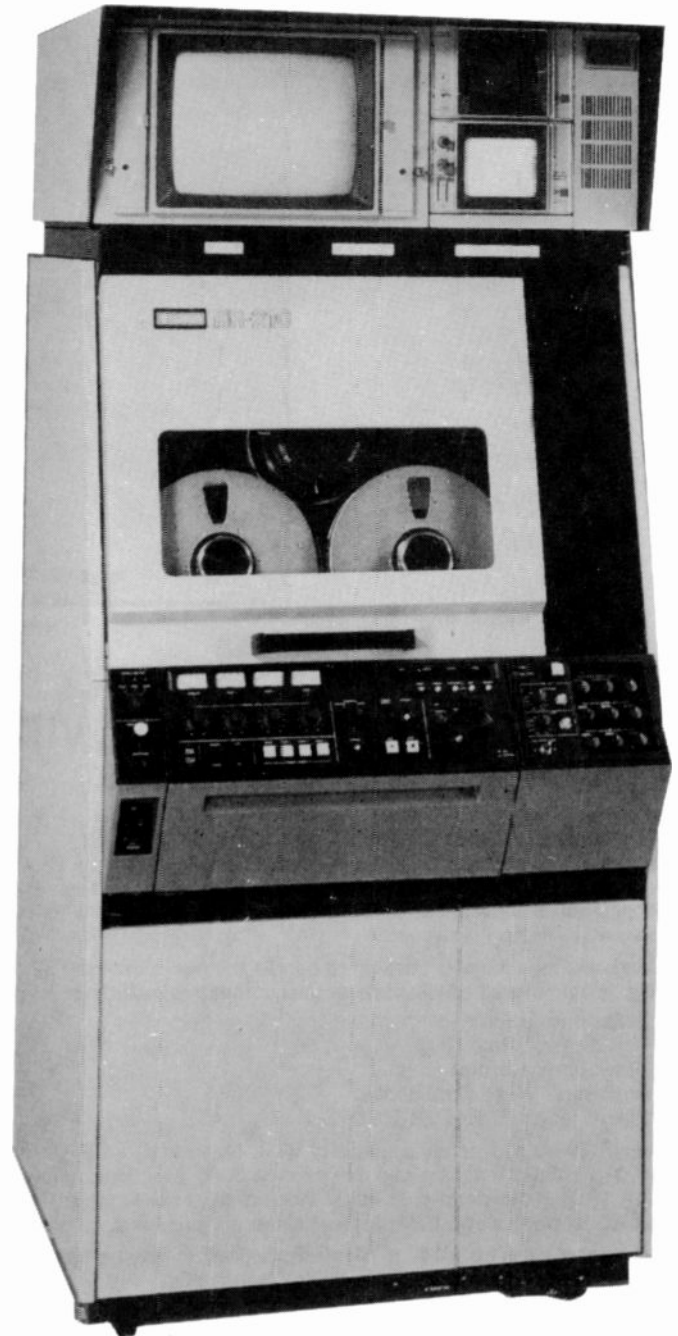



HR-300 HST System

## TYPE "C" VIDEO TAPE RECORDER

### HR-300 Three Hour Type "C" VTR

Designed for 3 hours of continuous record and playback, the HR-300 extends the Hitachi VTR line and opens new opportunities in videocassette duplication, delayed network feeds and film to tape transfer, to name just a few.

Based on a new transport design to handle the rigors of larger 3 hour reels, it employs all of Hitachi's exclusive features including:

- Retracting Guide
- "PRO" Tape Path
- Non-Contact Drum
- Audio and Video Confidence
- Slow-Motion ¼ Rev-2X FWD

The HR-300 is not merely a specialty VTR, but rather, a full production and editing machine capable of all editing functions, allowing inserts, assemblies and split edits. Additionally, slow-motion, front access electronics and full transport cover are provided.

Various reel sizes from 14" to 5" plastic spot reels may be used with no modifications, adding to the HR-300's versatility.

### HR-300 HST System

Three hour studio model recorder/reproducer, conforms to SMPTE type "C" standards. Features HST, precision retracting guide system, non-contact air drum, sync head, jog/shuttle control, on-board editor, front access electronics and color framing. Console features; audio monitoring, video test switching and interconnect cables. **\$95,000.00**

#### System Configuration

- HR-300 3 hour type "C" VTR
- TC-200 Digital Time Base Corrector
- CN-300 HR-300 console with monitoring bridge, less monitors
- HST Slow-Motion ¼ Rev — 2X FWD

Take-up reel, operations/service manual, set of extender cards.

#### HR-300 System w/o HST

**\$87,500.00**

#### System Configuration

- HR-300 3 hour type "C" VTR
- TC-200 Digital Time Base Corrector
- CN-300 HR-300 console with monitoring bridge, less monitors, take-up reel, operations/service manual, set of extender cards.

**PORTABLE COLOR CAMERAS**
**FP-10UC Portable Color Camera**

The Hitachi FP-10UC is a self-contained color camera with a new High Resolution tri-electrode 1-inch SATICON pickup tube, providing the best results ever attained from a single tube camera.

- Built-in Bias Light
- ABO (Automatic Beam Optimizer)
- Serial Data Transmission System
- Full Automatic Function
- +6 dB, +12 dB High Gain Switch
- Built-in Color Temperature Filters
- Built-in Color Bar Generator
- Remote Controlled Subcarrier Phase Adjust
- Built-in Genlock
- RS 170A Sync Standard
- Built-in Vertical and Horizontal Contour Enhancer
- Studio Application
- Weight: 11.3 lbs.
- Dimensions: 3.9" x 10.2" x 11.6" (WHD)



FP-10L C

**FP-10UC Portable Color Camera**
**\$3,700.00**
**FP-21UF Portable Color Camera**

- Improved Prism Beam-splitter
- Excellent Operation even in low-light condition
- Crisp and Sharp Results
- ABO (Automatic Beam Optimizer)
- Portability
- Automatic Controls
- RS 170A Sync Standard (NTSC)
- Split-field Color Bars
- Studio Application
- Weight: 11.2 lbs.
- Dimensions: 3.6" x 11.5" x 14.8" (WHD)



FP-21UF

**FP-21UF Portable Color Camera**
**\$10,900.00**
**FP-22UD Portable Color Camera**

The new Hitachi FP-22UD is a professional high quality camera ideal for ENG, EFP and studio production, providing superior performance and operational simplicity.

- Improved Prism Beam-splitter
- Excellent Operation even in low-light condition
- Crisp and Sharp Results
- ABO (Automatic Beam Optimizer)
- Portability
- Full Automatic Controls
- Built-in Microprocessor
- Diagnosis System
- RS 170A Sync Standard (NTSC)
- Split-field Color Bars
- Studio Application
- Weight: 11.2 lbs.
- Dimensions: 3.6" x 11.5" x 14.8" (WHD)



FP-22UD

**FP-22UD Portable Color Camera**
**\$13,900.00**
**PROFESSIONAL COLOR TV CAMERAS**
**FP-50S Color Camera**

The Hitachi FP-50S is a fully developed new generation color studio camera adopting highly efficient prism optics and three 3/4-inch SATICON pickup tubes. Features include superb resolution, signal-to-noise ratio and color fidelity even under low lighting conditions.

- Lightweight
- Excellent resolution
- High Sensitivity and low noise
- Low lag
- Shading correction
- 3 position filter wheel
- Auto white balance
- Manual white balance (option)
- Color tone control
- Detail correction
- Internal/External synchronization
- Blanking width adjustment
- High brightness viewfinder
- Auto iris
- Auto Iris Closure
- Line-up Signals
- R, G, B Outputs
- Remote Control Flexibility
- Weight: 16.5 lbs.
- Dimensions: 6.3" x 10.2" x 13.8" (WHD)



FP-50S

**FP-50S Color Camera**
**\$13,900.00**
**FP-60S Studio Color TV Camera**

The Hitachi FP-60S Color TV Camera adopts a newly developed prism optics and three 1-inch SATICON pickup tubes, and features superb resolution, signal-to-noise ratio and color rendition. The camera head is of a sturdy die-cast aluminum construction and can be used in field applications under severe operating conditions as well as studio use.

- Prism optics and 1-inch SATICON tubes
- Built-in automatic beam optimizer
- Built-in bias light
- Built-in test signals
- Tilttable viewfinder
- Dual method for color temperature compensation
- Built-in iris servo amplifier
- Built-in shading compensators
- Extra video gain
- Built-in contour corrector
- Auto white balance
- Painting
- Masking amplifier (optional)
- Automatic wobbling circuits
- Negative G. signal for registration adjustment
- R, G and B signal outputs
- A level meter
- Built-in color bar generator
- Weight: 26 kg.



FP-60S

**FP-60S Studio Color TV Camera**
**\$25,670.00**

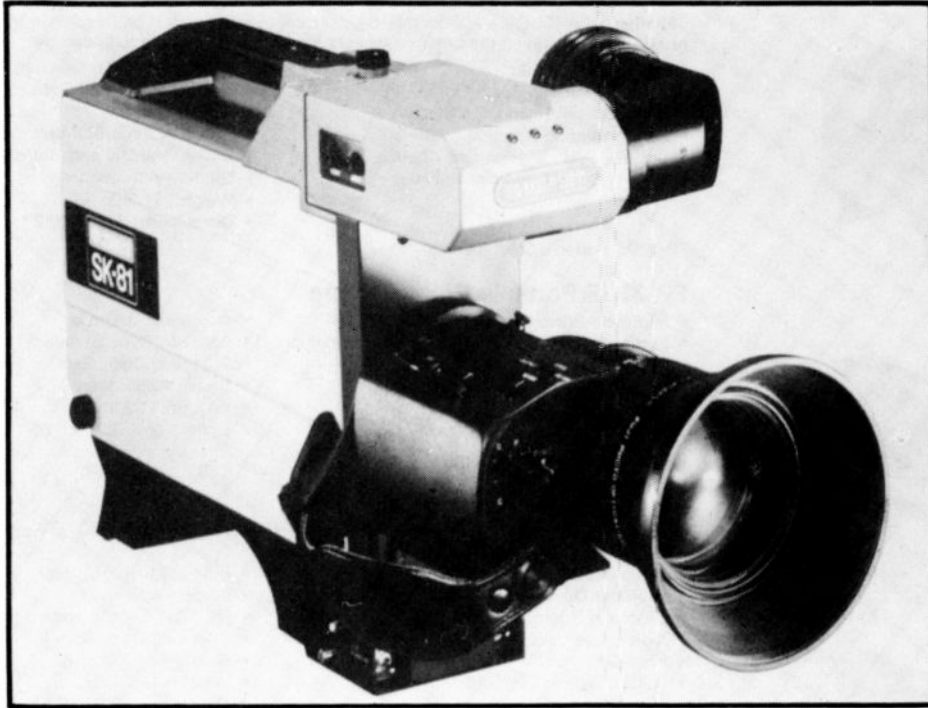

SK-81

**SK-81**

The Hitachi SK-81 is a new generation, ultra-light, EFP portable color television camera that provides unusually superior performance and operational simplicity.

Weighing only 4.6 kg (10.1 lb) the camera sits balanced on the operator's shoulder and provides the operator with full freedom to concentrate on picture composition.

The rugged magnesium alloy casting and excellent circuit stability make the camera withstand rough handling and extreme conditions of heat and cold. Built-in automatics for beam current, lens iris, white balance and black balance further make it possible for the camera to operate even under wide variations of lighting conditions.

Ample accessories are available for adding usefulness in ENG/EFP applications as well as in studio use.

The Hitachi SK-81 will work with professional results wherever you have the imagination and the physical courage to take it.

**FEATURES**

• **Ultra-Light and Rugged**

Advanced design of the camera housing with magnesium alloy casting, new construction of the optical and mechanical sub-assemblies and careful selection of the electronic parts have realized the compact, ultra-light and rugged, self-contained, hand-held camera. It weighs only 4.6 kg (10.1 lb) including 1.5-inch viewfinder and withstands rough handling and environmental extremes.

• **Improved Prism Beam-splitter**

A newly developed, high-speed (f1.4) prismatic beam-splitter, together with low-noise pre-amplifiers, provides high sensitivity and excellent signal-to-noise ratio. A deviation of optical registration due to temperature changes and a bias light shading of the prism are also improved substantially.

• **ABO (Automatic Beam Optimizer)**

The Hitachi developed ABO circuit greatly extends dynamic range, reduces comet-tailing and thereby guarantees easy highlight handling.

• **Auto White Balance**

White balance is achieved automatically in half a second by the "AUTO WHT" switch, if a white object is focused in the center of the picture. Digital memory retains the white balance even after the camera is turned to standby, or the power supply is disconnected.

• **Auto Black Balance**

Black balance is also automatic by turning on the "AUTO BLK" switch, which closes the lens iris and sets up the video black level in each color channel. Digital memory is used also for this control.

• **Auto Iris**

Automatic iris control by video level detection maintains constant video level under wide variations of lighting conditions.

• **Video Level Indicator**

For manual iris operation of lenses, a signal level indication of tiger stripes is superimposed on the viewfinder display.

• **Low Power Consumption**

The SK-81 may be powered from any of a conventional battery belt, an attachable battery pack, a car battery and an AC power adaptor. Low power consumption, at single + 12V DC assures continuous operation in excess of two hours with the battery belt or one hour with the attachable battery pack.

• **Auto Iris Closure**

A lens iris is automatically closed for protecting the camera tubes from possible damage due to highlight when the camera is turned to standby. It is also closed for 4 seconds after the "AUTO BLK" switch is turned on for setting up the video black level.

• **+9/ + 18 dB High-Gain Switch**

Master gain of +9/ + 18 dB operates on the gain of all three color channels simultaneously and is quite useful for the camera operation under extremely low light levels. Usable pictures with acceptable signal-to-noise ratio is provided down to 20 lux (2 fc) scene illumination at + 18 dB and f1.4.

**\$22,000.00**

**\$33,000.00**
**EFP Color TV Camera**

**SK-91.** The Hitachi SK-91 is a new generation, ultra-light, EFP portable color television camera that provides unusually superior performance and provides simplicity. Weighing only 4.4 kg (9.7 lb), the camera sits balanced on the operator's shoulder and provides the operator with full freedom to concentrate on picture composition. The SK-91 offers a usable picture in 5 seconds and runs for over 2 hours on a rechargeable battery belt. The rugged magnesium alloy casting and excellent circuit stability make the camera withstand rough handling and extreme conditions of heat and cold. Built-in automatics for beam current, lens iris, white balance and black balance further make it possible for the camera to operate even under wide variations of lighting conditions. Ample accessories including the Operation Panel, Remote Operation Unit, Digital Command Unit, 5-inch Viewfinder, etc. are available for adding usefulness in ENG/EFP applications as well as in studio use. The Hitachi SK-91 will work with professional results wherever you have the imagination and the physical courage to take it.

- **ULTRA-LIGHT AND RUGGED** — Advanced design of the camera housing with magnesium alloy casting, new construction of the optical and mechanical sub-assemblies and careful selection of the electronic parts have realized the compact, ultra-light and rugged, self-contained, hand-held camera. It weighs only 4.4 kg (9.7 lbs.) including 1.5-inch viewfinder and withstands rough handling and environmental extremes.
- **SHOCK- AND VIBRATION-FREE** — A new shock-mounted optical system, with prism, yokes and tubes packaged as a single assembly, assures registration stability and makes the camera virtually impervious even to severe shock, vibrations and jolts encountered in transportation.
- **RF INTERFERENCE-FREE** — Improved shields for tubes, yokes and preamplifiers guarantee practically interference-free operation even in the 120dB electro-magnetic field from MF to UHF.
- **IMPROVED PRISM BEAM-SPLITTER** — A newly developed, high-speed (f1.4) prismatic, beam-splitter, together with low-noise pre-amplifiers, provides high sensitivity and excellent signal-to-noise ratio. A deviation of optical registration due to temperature changes and a bias light shading of the prism are also improved substantially.
- **ABO (AUTOMATIC BEAM OPTIMIZER)** — The Hitachi developed ABO circuit greatly extends dynamic range, reduces comet-tailing and thereby guarantees easy highlight handling.
- **SHADING CORRECTION** — Adjustable H/V sawtooth, parabolic and portholing axis shading correction for each color channel, and also V sawtooth modulation shading correction are adopted to assure perfectly flat pictures.

- **2H CONTOUR CORRECTION** — 2-line horizontal and vertical out-of-green signals, level dependent with coring and comb-filtering, are added to R, G and B channels to ensure optimum picture sharpness with minimum noise contribution.
- **GAMMA CORRECTION** — Gamma correction is continuously adjustable in each color channel from 0.35 to 1, which permits easy matching to other cameras.
- **LINEAR MATRIX MASKING** — A linear matrix masking amplifier is built-in to get high-fidelity color rendition and fine tone-matching among the cameras.
- **AUTO IRIS** — Automatic iris control by video level detection maintains constant video level under wide variations of lighting conditions.
- **AUTO WHITE BALANCE** — White balance is achieved automatically in half a second by the "AUTO WHT" switch, if a white object is focused in the center of the picture. Digital memory retains the white balance semi-eternally even after the camera is turned off or to standby, or the power supply is disconnected.
- **AUTO BLACK BALANCE** — Black balance is also automatic by turning on the "AUTO BLK" switch, which closes the lens iris and sets up the video black level in each color channel. Digital memory is used also for this control.
- **VIDEO LEVEL INDICATOR** — For manual iris operation of lenses, an oversignal indication of tiger stripes is superimposed on the viewfinder display.
- **AUTO IRIS CLOSURE** — A lens iris is automatically closed for protecting the camera tubes from possible damage due to highlight when the camera is turned off or to standby, and for setting up the video black level when the "AUTO BLK" switch is turned off.
- **4-POSITION FILTER DISC** — A filter disc includes 3200° K, 4700° K, 6000° K +50% ND, and 0% ND filters. These filters, together with the auto white balance and auto iris, provide sufficient color temperature compensation and scene illumination correction.
- **POWER SUPPLY OPTIONS** — The SK-91 may be powered from any of a conventional battery belt, an attachable battery pack, a car battery and an AC power adaptor. Low power consumption of mere 20W at single +12 V DC assures continuous operation in excess of two hours with the battery belt or one hour with the attachable battery pack.
- **LOW BATTERY VOLTAGE WARNING** — A flashing LED in the viewfinder alerts the cameraman to low battery voltage.
- **STANDBY/OPERATE SWITCH** — The camera draws only 5% of the normal power in the "STANDBY" mode. Return to the "OPERATE" mode is accomplished in a few seconds.

- **+9/ +18dB HIGH-GAIN SWITCH** — Master gain of +9/ +18dB operates on the gain of all three color channels simultaneously and is quite useful for the camera operation under extremely low light levels. Usable pictures with acceptable signal-to-noise ratio is provided down to 20 lux (2 fc) scene illumination at +18dB and f 1.4.
- **MASTER BLACK CONTROL** — Master black level control is provided for brightness matching to other cameras.
- **REGISTRATION CONTROLS** — H/V centering trim pots in R and B channels and R, G, B, R-G and B-G monitor outputs are provided to check and control fine registration.
- **SPLIT-FIELD COLOR BARS** — A built-in color bar generator produces split white with 75% and 100% white as well as six hues and black. This makes it easy to set 100% modulation level in VTR recording.
- **SEPARATE VIDEO OUTPUTS** — In addition to the two isolated encoded video outputs for line and VTR, a separate monitor output is provided. This delivers R, G, B, R-G, B-G or encoded video signal by switch selection.
- **RETURN VIDEO INPUT** — An external synchronous or non-synchronous composite video signal may be switched in the viewfinder.
- **GENLOCK INPUT** — A built-in sync generator can be genlocked to an external color composite or black burst signal. Horizontal pulse timing and sub-carrier phase are adjustable. In a PAL model the genlock unit is externally attached to the camera.
- **BLANKING WIDTH ADJUSTMENT** — Both H and V blanking widths are adjustable over a wide range to compensate for the errors introduced into the recorded video signal in the recording/time base correction/editing process.
- **HIGH-RESOLUTION VIEWFINDER** — A 1.5-inch, tiltable, high-brightness, high-resolution viewfinder with a magnifying eyepiece assures precise focusing and picture composition. A built-in peaking circuit further assists in attaining sharp optical focusing of the lens. An optional 5-inch viewfinder is also available for studio use.
- **VIEWFINDER INDICATORS** — The 1.5-inch viewfinder includes the following indicators: Tally, White Balance, Video Level (tiger stripe), Battery Voltage and VTR Record.
- **HI-FI MICROPHONE AMPLIFIER** — A built-in microphone amplifier accepts a mike having output level from -45 to -60dBm. Two-time-constant limiting amplifier assures natural sounds even when a sound level varies abruptly.
- **VTR TRIGGER BUTTON** — A trigger button is provided on the lens for remote control of a portable VTR. VTR record is indicated in the viewfinder with an LED.

**SK-91P** Same as SK-91 Package except with XQ-1427 RGB Plumbicons **\$33,000.00**

**SK-91D** Same as SK-91 Package Except with XQ-2427 RGB Diode Gun Plumbicons **\$34,500.00**



**DK-5000 Series**  
**\$17,900.00 Without Lens**

**DK-5000 Series Super Small 3-Tube Color TV Camera for Medical or Laboratory Use**

The Hitachi DK-5000 series is a complete system of 3-tube color television cameras for medical use including microscope systems.

For surgical operation, medical research and education, microscopic inspection, and other applications, the camera views the image as the human eye does, and the pictures are displayed conveniently on color monitors.

For general medical applications, an optional 1.5-inch viewfinder attached to the camera head makes camera focusing and framing simple.

In microscope applications, when the camera head prevents you from viewing into the microscope eyepiece, you can choose the model, DK-5001, which is the same size as the DK-5000 but rotated 90° in mounting angle. Optional accessories, such as a microscope adaptor, automatic light control unit, etc. are available for microscope applications.

**Dimensions and Weight**

**DK-5000 Camera Head** — 80mm x 258mm x 185mm (3.1" x 10.2" x 7.3") (W x H x D), 2.5 kg. (5.5 lbs.).

**DK-5001 Camera Head** — 258mm x 80mm x 185mm (10.2" x 3.1" x 7.3") (W x H x D), 2.5 kg. (5.5 lbs.).

**DE-5000 Def. Unit** — 433mm x 43.5mm x 252mm (17.0" x 1.7" x 9.9") (W x H x D), 3.5 kg. (7.7 lbs.).

**CU-5000 CCU** — 433mm x 132.5mm x 360mm (17.0" x 5.2" x 14.2") (W x H x D), 16 kg. (35.2 lbs.).

**FEATURES**

- Small size and light weight. The camera head, in spite of the 3-tube design, is so small and light that it can be handled easily and installed directly on a microscope.
- Excellent resolution. 3/8-inch separate-mesh Chalcon\* tubes (E-5092D) or SATICON\*\* tubes (H9311A) and improved electronics provide 550 lines of resolution at image center.

- Faithful color fidelity. Separate R G and B video outputs are available at the rear of the CCU for use with an RGB color monitor. This method gives better resolution and eliminates phase errors in the color signal.
- Automatic white balance. Color balance of the R G and B channels is achieved automatically by pressing the "AUTO WHITE" button on a scene with white content. White balance is retained by an IC memory for over two days even with camera power off. Manual white balance is also available (optional module).
- Color tone control. Fine color tone matching between the monitor display and the object is adjusted by the "COLOR TONE" control. This does not affect the white balance.
- +6/ +12 dB high gain switch. Camera sensitivity can be increased by a factor of two (+6 dB) or four (+12 dB) as required for dark scenes by a convenient control on the CCU.
- Detail correction. The self-contained horizontal detail correction circuit ensures sharp pictures. An optional one-line vertical detail unit further adds picture contour sharpness.
- Multiple synchronization. Color sync generator (NTSC) is incorporated to permit completely independent camera operation. If the synchronous operation of more than one camera is desired for system integration, external drive or optional genlock synchronization is available. In the "EXT" mode of operation, the external drive pulses supplied to the respective inputs can drive the camera sync system. If an optional genlock unit is used, the camera sync generator can be locked to external color composite or black burst signal.
- Built-in color bar generator. A built-in full-field color bar signal generator facilitates the correct adjustment color monitors.
- Operational flexibility. The 19-inch rack-mountable camera control unit (CCU) can be separated from the camera head by up to 300 m (900 ft.) and has easy access to the "POWER", "AUTO WHITE" and "COLOR TONE" controls for routine operation. The camera deflection unit can also be mounted in the 19-inch rack and separated from the camera head by 20 m (60 ft.). It has all the controls necessary for the camera head.
- Prices available on request

\*and\*\* Trademark



# BROADCAST STUDIO/PORTABLE COLOR TV CAMERA

## SK-96 Studio/Field Hand-Held Convertible Color TV Camera

In addition to being a convertible studio/field and hand-held camera, the SK-96 also has a complete Camera Control Unit (CCU). With the SK-96, you can produce programs anytime, anywhere with assurance of superior picture quality.

### FEATURES

#### Excellent Picture Quality

- Three 3/8-inch SATICON\* tubes (H8397A) and an extra-small, highly efficient beam-splitting prism provide 500-line horizontal resolution and a signal-to-noise ratio of more than 51dB.
- Built-in 2H contour corrector with comb filter guarantees sharp, crisp pictures.
- Built-in linear matrix masking amplifier gives high-fidelity color rendition.
- Standard I & Q encoder with switchable color bar generator produces full bandwidth signals.

<b>SK-96</b>	Convertible Studio/Portable 3 Tube Saticon or Plumbicon*, Camera with optional Triax available. Features ABO, 2 Line Enhancer 550 lines resolution	
<b>SK-96</b>	<b>Studio Camera System</b>	<b>\$44,975.00</b>
	Package includes: HP-96 Camera head w/ (3) H3897A or Plumbicons* • VF-702 7" Viewfinder • SVM-96 Service manual • SH-96 Studio housing • CU-96 Cam. control • MK-96 Maint. kit	
<b>PK-96</b>	<b>Portable Conversion Kit</b>	<b>\$ 5,000.00</b>
	PH-96 Portable housing • SP-60 Shoulder pad • VF-151 1.5" Viewfinder • CLP-96 Case for head	
<b>SKP-96</b>	<b>Portable Camera System</b>	<b>\$39,735.00</b>
	HP-96 Camera head • VF-151 1.5" viewfinder • SP-60 Shoulder pad • SVM-96 Service manual • PH-96 Portable housing • CU-96 Cam. control • MK-96 Maint. kit • CLP-96 Case for head	
<b>C-050-UC</b>	<b>Camera Cable</b>	
	50' camera cable	\$ 573.00
<b>C-100-UC</b>	100' camera cable	780.00
<b>C-200-UC</b>	200' camera cable	1,195.00
<b>C-300-UC</b>	300' camera cable	1,597.00
<b>C-600UC</b>	600' camera cable	2,803.00
<b>CMC-UC</b>	Mating connector to join cam. cables	66.00
	<b>Accessories</b>	
<b>WFM-96</b>	RGB Sequence plug-in module	\$ 690.00
<b>OP-96</b>	Operation panel	1,605.00

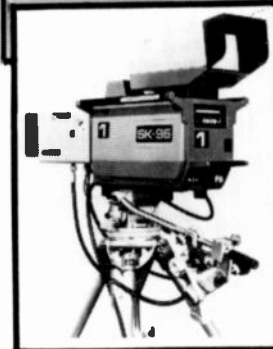

<b>DUS-96</b>	Digital Cable Adaptor (for studio) C-101UC Cable included	<b>\$21,500.00</b>
<b>H-8397A</b>	Spare Saticon	1,680.00
<b>BP-96</b>	Battery pack w/ battery	1,340.00
<b>BC-96</b>	Battery charger	780.00
<b>BB-96</b>	Spare battery	750.00
<b>CLC-96</b>	Carrying case for CCU	357.00
<b>CLS-96</b>	Carrying case for studio head	357.00
<b>SPK-96</b>	Spare parts kit	970.00
<b>SVM-96</b>	Spare service manual	150.00
<b>TT-96</b>	Training tape	75.00
	<b>Lenses (Fujinon)</b>	
<b>A10X10RS</b>	Portable 10:1 10-100mm F1.9	\$ 3,425.00
<b>A12X10RS</b>	Portable 12:1 10-120mm F1.9	4,500.00
<b>A14X11AERS</b>	Portable 14:1 11-154mm F1.9w/2X	6,798.00
<b>A17X9AERM</b>	Portable 17:1 9-153mm F1.7w/2X	10,830.00
<b>A10X10.5RW</b>	Studio 10:1 10-105mm F1.4	7,125.00
<b>A22X12.5ERW</b>	Studio 22:1 12.5-275mm F1.6w/2X	24,090.00
<b>AF6A</b>	Portable 6mm F1.4	3,150.00
	All lenses auto iris, portable lenses are servo zoom, except AF6A	
	<b>Lens Accessories</b>	
<b>SRD-43</b>	Servo lens grip portable lenses	\$ 451.00
<b>SCK-43</b>	Rear conversion kit (requires SRD-43)	650.00
<b>WC-1214</b>	Wide converter for 12X and 14X lenses	1,225.00
<b>TC-1214</b>	Tele converter for 12X and 14X lenses	1,225.00
<b>LS-12</b>	Lens shroud for portable lenses 12X	335.00
<b>LS-14</b>	Lens shroud for portable lenses 14X	335.00
<b>LS-17</b>	Lens shroud for portable lenses 17X	335.00

**CAMERA HEAD**

- **Highly efficient prism optics:** A newly developed f1.8 prism optics are used in conjunction with 1-1/4" Plumbicon™ tubes to provide a high signal-to-noise ratio of 54 dB at 2000 lux and f5.6. The optical filters have been dust-proofed to virtually eliminate dust problems.
- **Six-position ND and color filter discs:** Two filter discs, one for ND filters and the other for color filters have been provided, with independent filter selection possible from both the RCU and the SCU. The discs are servomotor driven and may be rotated in either direction.
- **Improved registration and optical axis accuracy:** By using an independent four-corner adjustable dynamic registration compensation unit, compensation to within 0.05% over the entire picture area is possible. This can be achieved by means of either the auto-setup or the remote control from the SCU. The compensation data is stored in RAM memory with a back-up battery. The optics, coil assemblies and zoom lens are mounted as a unit to ensure that mechanical distortion does not affect the optical system or coil assemblies and to eliminate the effects of external mechanical stresses on registration and optical axis accuracy.
- **Comet tails eliminated by ABO (Automatic Beam Optimizer):** The Hitachi developed ABO circuit allows the beam current to be increased up to 16 times versus only 4 times the normal setting for conventional systems, a limitation imposed by considerations of picture quality. This means that comet tails can be eliminated without the usual accompanying misregistration, loss of resolution, and increase in dark current.
- **High-performance viewfinder:** A bright, high-resolution CRT has been used in the viewfinder to provide an easy-to-view image even for outdoor shooting. The viewfinder can be tilted from +25° to -45° and rotated +/-90° to set it at any arbitrary angle.
- **Easy-to-use video select button:** R, G, B, minus G, and two return video signals (AUX-1 and AUX-2) can be switch-selected as the viewfinder video signal.
- **Convenient monitor output on the camera head:** A separate video output has been provided on the camera head to be used for floor monitors, etc.
- **Red and green tallies:** The viewfinder is provided with both red and green tallies, the red one for live shooting and the green one used for VTR recording.
- **Built-in microphone amplifier:** The camera head is provided with a built-in microphone amplifier with limiter. The audio output is balanced to prevent the pickup of noise from the camera cable.
- **Test signals provided to simplify setup:** Test signals are used for easy calibration of the output of each amplifier stage. The signals are applied in sequence, starting from the process amplifier and walking back until the preamplifier is calibrated. The test signals may be applied to the input of the preamplifier first stage, process amplifier-1 and process amplifier-2, and consist of a 100% and 200% level sawtooth waveform which can be used for level calibration as well as verification of gamma, knee point, slope and clipping point.
- **Designed for easy servicing:** The camera head and CCU PC boards are simple to remove and marked on both sides, making parts easy-to-find for quick servicing or inspection. Another serviceability feature is a coil assembly that can be removed while the camera is mounted to the dolly.

**CCU**

- **Compact design:** The CCU is designed as a dedicated camera control unit for computer controlled cameras. Both the video processing section and the computer section have been housed in one compact package.
- **Linear matrix masking:** A built-in linear matrix masking circuit is provided and ensures faithful color reproduction and easy tone matching among cameras.
- **High-performance contour corrector:** Compensation signals derived from the R and G channels provide clear, crisp images of even red subjects. The contour correction signals are automatically processed to match the type of subject, maintain optimum compensation and ensure natural images.

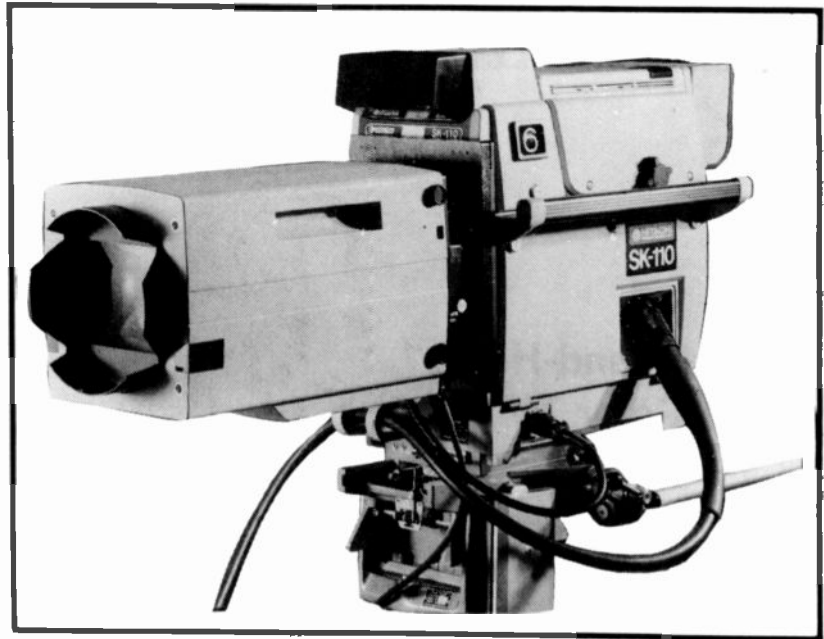

**SK-110 Broadcast Quality Camera**  
**\$78,000.00**

- **Standby mode operation:** Three operating modes have been provided to reduce power consumption and extend the life of the pickup tubes and CRT.
  - (1) **CCU POWER:** Main power supply is switched on; the CCU is operating.
  - (2) **POWER:** The camera head is on and the heaters of the pickup tubes and CRT are supplied with 50% of the normal voltage.
  - (3) **BEAM:** The pickup tube beams are switched on and the camera operates.
- **Genlock:** The SK-110 is genlocked to an external sync signal when composite sync and subcarrier signals are applied. Horizontal and subcarrier phases can be adjusted manually. If required, genlocking by means of a black burst signal can also be provided.
- **Built-in SMPTE/VIT color bar generator:** A color bar generator conforming to the latest SMPTE standards has been built-in for convenient adjustment of monitors. Also built-in is a VIT color bar generator, allowing monitoring of the characteristics of the encoder and the transmission line while on the air.
- **High-reliability LSI process amplifier:** Camera picture quality is greatly effected by the stability of the process amplifiers used. LSI process amplifiers have been used in the SK-110 camera to provide stable operation with respect to temperature variations and eliminate variations between channels. They provide both picture quality and high reliability and represent the most advanced step in a camera of this class.
- **Special effects:**
  - (1) The horizontal and vertical deflection currents can be independently reversed, a feature useful in picking up mirror images.
  - (2) The video polarity of the R, G, and B signals can be independently inverted.
  - (3) A circuit has been provided which can be used to provide swinging of horizontal deflection by means of an externally applied low frequency signal.
- **Encoder with variable gamma (contrast):** Gamma control of luminance and chrominance signals is linked and can be adjusted by remote control, making adjustment of the picture contrast very easy, even under such difficult conditions as those encountered outdoors.
- **Iris:** In the Auto Iris mode the lens iris is automatically adjusted according to subject illumination. In manual mode, the center value and adjustment range of the iris are set by the sense and range controls of the SCU or RCU. This feature makes operation in the studio where light variations are small extremely simple. The iris values are visible on the SCU and RCU LED display.

**AUTOMATIC SETUP**

- **Zero method control:** The zero method of control is capable of controlling the R, G, and B channels, thus eliminating the troublesome manual adjustment of the G channels required in the G channel reference method. The system has been completely automated, and a parallel control system can set up multiple cameras simultaneously in just 2 minutes.
- **Control of multiple cameras:** By using a DSU for every group of six cameras, up to 24 cameras can be controlled with just one SCU. By adding a TSU control capabilities can be expanded up to 42 cameras using two SCUs, providing all the flexibility you will ever need.
- **Automatic setup modes:** Five automatic setup modes have been provided; full, registration, color balance, G-reference, and white balance. These can be selected from to suit the picture conditions at the time. In addition, manual control from either the SCU or RCU is possible, with all normal operational controls accessible manually.
- **Data files:** Five data files are provided except for the AUTO data file. Automatic setup data is automatically stored in the AUTO data file. It is possible to store or erase the manual setup data from the SCU in the five data files by operating the entry or reject switch.
- **Fault diagnosis:** Fault diagnosis of the camera video system, power supply and pulse system is performed automatically to detect failures. Diagnosed results are printed out on the typewriter. This system has greatly simplified camera maintenance by providing quick and accurate information on failures.
- **Quick check:** When the SCU Check switch is depressed, registration (G-reference) and color balance (G-reference) are automatically checked and, if the required accuracy is not being obtained, the readjustment is automatically made.
- **Scroll display and automatic setup status display:** The results of the fault diagnosis and the quick check are displayed on a scrolled picture monitor character display. The scrolling display may be stopped at any desired point for viewing. The status of the automatic setup function (controlled parameters and their status) may also be viewed on the picture monitor character display.
- **Remote control:** The SCU, TSU, DSU, and CCU may be connected with just three twisted-pair cables and be separated from one other by up to 1000m (3000 ft.). The CCU and RCU may be connected using three twisted-pair cables and separated up to 100m (300 ft.). If the power supply is provided externally to the RCU the distance to the CCU can be extended up to 1000m (3000 ft.).





**GP-6M**

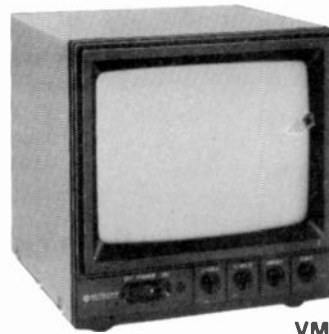

**VM-910A**

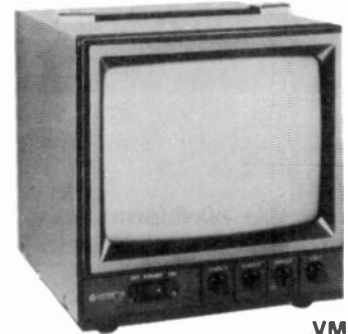

**VM-906A**

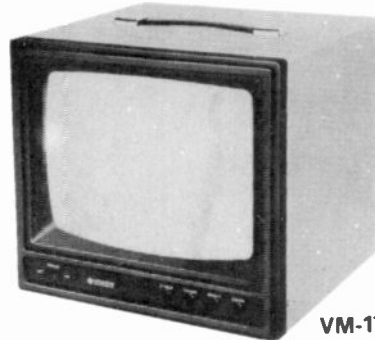

**VM-173**

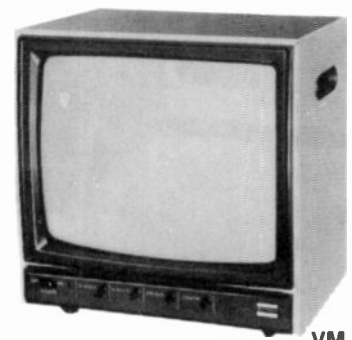

**VM-129**

**GP-6M Saticon**

The Hitachi GP-6M color camera makes use of a 3/8" SATICON\* pickup tube employing a single-frequency separation system. It has a variety of useful features such as Auto-Iris and power zoom used with standard 6x zoom lens and is provided with a 1.5" tiltable electronic viewfinder, and a removable boom-type electret condenser microphone is also included making the GP-6M a full-feature shoulder-type camera.

**Features**

- Bright, sharp picture even at 50 lux using a high-sensitivity Saticon tube
- 6x power zoom lens with built-in Auto-Iris and exposure compensation functions
- A simple white balance control allows adjustment of color at any time to ensure beautiful color picture
- A Power-Save switch cuts the power-consumption of the GP-6M to 1/4 of normal power
- A unidirectional boom microphone picks up just the sound at which you are aiming
- An electronic viewfinder enables monitoring of recorded pictures
- Built-in Macro function adds a new dimension to video recording
- Designed-in ease-of-use. Both zoom and switches are one-hand operable

**\$1290.00**

**VM-Series B/W Video Monitors**

**Common Features**

- Reliability: Solid state circuitry using an IC and silicon transistors ensures high reliability
- Stable picture: Even played back pictures of VTR can be displayed without jittering
- Looping video input: Video input can be looped through with built-in termination switch
- External sync operation (available as option for U and C types)
- Front panel controls: Brightness, contrast, vertical hold, horizontal hold, power ON/OFF

**VM-910A 9" Monitor**

The Hitachi VM-910 is a solid state black and white video monitor that displays video signals from Hitachi CCTV cameras, VTRs and other signal sources.

**Features**

- 500 lines horizontal resolution: Horizontal resolution in excess of 500 lines is achieved at picture center
- Compact construction: Two monitors are mountable side by side in a standard 19-inch rack
- Dimensions: 8.6"W x 8.6"H x 9.2"D (219 x 219 x 234mm)
- Weight: 13.2lb. (6 Kg.)

**\$240.00**

**VM-906A 9" Monitor**

The VM-906 is an IC-incorporated, transistorized video monitor. It offers high resolution and high deflection linearity. This model is a high-grade video monitor capable of fulfilling all requirements.

**Features**

- 700 lines horizontal resolution: Horizontal resolution in excess of 700 lines is achieved at picture center
- Excellent linearity: Deflection linearity is less than 1%
- DC restoration switch
- Compact construction: Two monitors are mountable side by side in a standard 19-inch rack
- Dimensions: 8.6"W x 8.6"H x 9.2"D (219 x 219 x 234mm)
- Weight: 14.3lb. (6.5 Kg.)

**\$310.00**

**VM-129 12" Monitor**

The Hitachi VM-129 is a solid state black and white video monitor that displays video signals from Hitachi CCTV cameras, VTRs and other signal sources. This model ensures stable picture with low distortion and high resolution. A DC restoration circuit is built-in.

**Features**

- 700 lines horizontal resolution: Horizontal resolution in excess of 700 lines is achieved at picture center
- Excellent linearity: Deflection linearity is less than 1%
- DC restoration switch
- Dimensions: 12.5"W x 11.2"H x 12.5"D (318 x 284 x 316mm)
- Weight: 22lb. (10 Kg.)

**\$390.00**

**VM-173 17" Monitor**

The Hitachi VM-173 is a solid state black and white video monitor that displays video signals from Hitachi CCTV cameras, VTRs and other signal sources.

**Features**

- 700 lines horizontal resolution: Horizontal resolution in excess of 700 lines is achieved at picture center
- Excellent linearity: Deflection linearity is less than 2%
- DC restoration switch
- Dimensions: 16.1"W x 15.2"H x 13.3"D (408 x 386 x 337mm)
- Weight: 37.5lb. (17 Kg.)

**\$430.00**

**V-059B Portable Waveform Monitor/Oscilloscope With Battery**

**Waveform Monitor**

<b>V-059B</b> Portable waveform monitor/oscilloscope with battery .....	<b>\$1200.00</b>
<b>AD-058B</b> Spare battery .....	<b>200.00</b>

Model V-059B combines a TV waveform monitor and a single trace 7 MHz portable oscilloscope in a small, lightweight body (6.4 lbs.). Features include keyed DC restorer; TV Sync-separator with automatic LINE/FIELD rate triggering selection by Time/div control; and AC, DC or rechargeable battery powering capability. It is ideal for video equipment servicing applications and for monitoring TV waveforms in electronic field production. The V-059B has a 10 mv/div deflection factor at 2 MHz bandwidth. A 3-½ inch 8 x 10 div rectangular internal graticule CRT assures accurate and easy measurements. The V-059B has a battery protection circuit.

**FEATURES**

- Small size and lightweight: 6.4 lbs.
- AC, DC or battery powered
- Sharp trace CRT with parallax-free internal graticule
- Keyed DC Restorer for TV waveform monitoring application
- TV Sync separator automatic LINE/FIELD rate triggering selection by time/div control switch
- Selectable input impedance, 1M ohm/75 ohm
- Low line/battery voltage warning indication and battery protection
- All-solid-state reliability and easy maintenance
- 15-position carrying handle optimizes viewing angle
- 2V/2H sweep rate selectable
- External Horizontal sweep mode provided
- External -40, 0, 100 IRE Unit graticule on light filter
- Charging indication by brightness of LED

**COMPOSITION**

1. V-059B oscilloscope . . . 1	Needle tip attachment . 1
2. AD-058B battery pack . 1	Alligator attachment . . 1
3. External graticule (attached to oscilloscope) . . . . . 1	Ground lead . . . . . 1
4. AT-10P1.5 probe . . . . . 1	5. Protective cover . . . . . 1
Probe housing . . . . . 1	6. Viewing hood . . . . . 1
Pincher tip . . . . . 1	7. Screw driver for adjustment . . . . . 1
	8. Operation manual . . . . . 1

**DIMENSIONS**

Height .....	85 mm - 3.35"
Width .....	198 mm - 7.8"
Depth .....	292 mm - 11.5"
Net Weight .....	2.9 kg - 6.4 lbs.

**V-099 Television Waveform Monitor**

<b>V-099</b> .....	<b>\$1,350.00</b>
<b>Battery AD-099</b> .....	<b>250.00</b>
<b>Triple Rackmount RM-099</b> .....	<b>200.00</b>

Hitachi's new V-099 Waveform Monitor is rack mountable. Three of these units will fit side-by-side in a standard 19" rack mount.

The V-099 features a bright (2 KU) 3½" square CRT.

V-099 may be operated on AC, with optional battery pack, or from external DC source.

**FEATURES**

- Power:
  - Line voltage — AC 115 volts within 10%
  - Line frequency — 50 to 400 Hz
  - Power consumption — 25 watts or less at normal line voltage
  - External DC source — DC 11.5 to 14 volts at EXT terminal
  - Optional battery — 2.2 hours or more
- Dimensions: 145 (W) x 88 (H) x 470 (D) mm
- Weight: Approx. 3.5 kg (without battery pack). Approx. 2.5 kg. (battery pack).
- Option: 19" x 3.5" rack (mountable up to 3 sets), Battery pack.

**AD-058B Battery Pack**

Model AD-058B provides up to three hours of operation for model V-059B. The pack may be attached to the bottom of the aforementioned oscilloscope.

**SPECIFICATIONS**

- Output Power: 12V, 2.7 Ah from full charge (sealed lead acid gel).
- Charging Source: V-059B oscilloscope with power cord connected to AC line; scope operation is stopped in the charging mode.
- Charging Time: 15 hours, charging current is automatically set to trickle level at full charge.
- Ambient Temperature: Operating 0°C to +40°C, Charging 0°C to +40°C, Storage 0°C to +40°C.
- Dimensions: 1.65"(H) x 6.38"(W) x 10.3"(D); 42 mm x 162 mm x 262 mm.
- Net Weight: 1.7 kg., 3.74 lbs.



HM ELECTRONICS, INC.

# PROFESSIONAL AUDIO SYSTEMS



22  
22E  
24E



22F  
22EF  
24EF

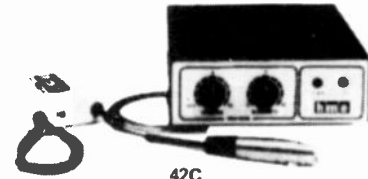

42C

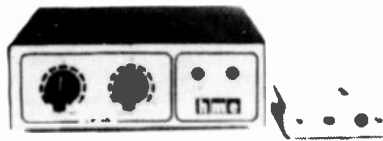

22R

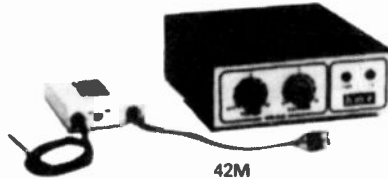

42M

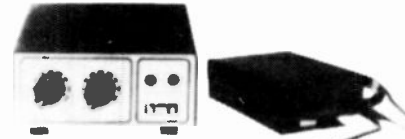

64E

## BODY-PAC WIRELESS MICROPHONE SYSTEMS

### SYSTEM 22 - WORKHORSE OF THE PROFESSIONAL LINE

Physically the same as the 22E but without Dynamic Expansion, the System 22 handles the full 95dB input range by the use of a fast attack, slow release soft compressor built in to the transmitter. The compressor function is adjustable to suit your preference, from 4:1 to hard limiting.

Included are all other outstanding features of the 22E.

The pocket transmitter features jumper selection for electret microphone bias and on some models a 50/100mW double-power mode for extra range.

### SYSTEM 22E - WITH DYNAMIC EXPANSION

Incorporating HME's Dynamic Expander circuits, the 22E allows an incredible 95 dB dynamic range without limiting.

The 22E consists of a rugged pocket transmitter, for use with your own dynamic or electret microphone, and a broadband professional receiver. Both are packaged in a fitted road case.

The snap-open transmitter is powered by a single, replaceable 9-volt alkaline transistor battery for 8 hours continuous operation.

A Dynamic Expansion receiver provides a balanced, 600 ohm line level or mic level output, plus a completely separate monitor output with independent front-panel level control. A power logic circuit provides automatic, transient-free selection of ac power, external battery and then internal battery for interruption-free programming (internal batteries are optional). A large meter face indicates audio and RF levels plus battery condition. Add an AD-5 or AD-10 antenna diversity system to insure dropout free reception.

### SYSTEM 24E PROFESSIONAL UHF LO-BAND (400-470 MHz) WIRELESS MICROPHONE SYSTEM

The System 24E Professional UHF Microphone System is designed for applications requiring the highest quality in sound reproduction and reliability.

The HME System uses the FM (frequency modulation) transmission method in the UHF band, plus an audio processing technique called Dynamic Expansion. By using HME Dynamic Expansion, the System 24E reproduces the input signal linearly up to 95 dB at the balanced audio output. In other words, a Dynamic Expansion Wireless Mic System sounds exactly like a cabled microphone. There are no audio gain adjustments required on the transmitter. The only audio adjustment on the receiver is internally set at the factory to be equivalent to a wired microphone.

The system consists of a Pocket Transmitter and a Receiver. The transmitter is about the size of a cigarette pack and comes equipped with a 6" long flexible antenna wire. It is compatible with any electret or dynamic type microphone, and requires only one standard 9 Volt alkaline battery.

The receiver is simple to operate and comes equipped with whip antenna. The receiver can also be battery operated. Balanced audio output is provided at either MIC "LINE" level.

### SYSTEM 22F - COMPRESSOR/LIMITER TRANSMITTER WITH FLAT PAC RECEIVER

An ideal system for remote broadcasting, ENG, or with battery-operated tape recorders. The same transmitter used in the System 22 provides a leveled output perfect for transmission or recording. An all-new compact receiver operates from internal batteries (replaceable or rechargeable) or from a wide variety of external sources.

### SYSTEM 22EF - WITH FLAT PAC RECEIVER AND DYNAMIC EXPANSION

The all new System 22EF combines the breathtaking range of Dynamic Expansion with the convenience of HME's new, compact Flat Pac receiver.

The 22EF is ideal for remote-location usage. Small, dc or battery powered, the receiver can be used directly with Nagra (or other) portable recorders.

The rugged pocket transmitter is the same as that used in the 22E, providing a system performance as loud and as silent as a wired microphone.

HME offers the System 22R for those requirements where professional performance is desirable but budgeting limitations are also important. It combines the System 22 Professional transmitter with the System 42 Executive receiver.

The easy-to-use Executive receiver has a single-ended output (phono jack) with front panel volume control. It connects easily to any PA system, and operates over a range of 100 ft. adverse, up to 1000 ft. line-of-sight.

### SYSTEM 42M - READY-TO-USE HI-BAND PERFORMANCE

The "Executive" System 42M is recommended for applications requiring high quality sound and minimal installation or adjustments. The transmitter comes complete with a small microphone and antenna permanently attached. All of the features and advantages of the WM 125 Professional transmitter, with the exception of audio limiting, are found in this system.

The matching receiver contains all of the fundamental qualities of the WM 125. It retains all of the radio frequency features, and may be operated 200 ft from the microphone under adverse conditions, or up to 1000 ft. line-of-sight. The full frequency response of the Executive system and the radio frequency advantages of Hi-Band makes it ideal for music as well as voice.

### SYSTEM 42C - ADAPTABLE TO YOUR MICROPHONE

If you prefer to use your own microphone, including a hand-held mic, the Model 42C comes with a standard XL 3-pin connector on a four foot cable attached to the transmitter.

The advantages of a Diversity System (HME Models AD-5 or AD-10) can be utilized with the System 42.

### SYSTEM 64E - HI-QUALITY PERFORMANCE FROM A LO-BAND SYSTEM

This easy-to-use wireless microphone system brings the freedom of cord-free performance to every user. The "Universal" System 64E is ideal for lectures, presentations, auctions and other activities not requiring professional sound performance. Using HME's exclusive Dynamic Expansion, you won't hear ignition noise interference, or annoying business radios. We're also using newly created radio frequencies for Low Power Devices only. Other New features: Battery Status Lite Indicator - Diversity Antenna reception - Balanced audio output option.

The small, lightweight electret microphone, supplied with the system, is coupled to a high impact ABS transmitter case which really can take rugged treatment. A belt clip on the transmitter provides a convenient way of attaching the transmitter to the user. A standard 9 volt alkaline battery gives about twelve hours of continuous operation.

Three systems can be used simultaneously with an expected operating range of 50 feet under most conditions, or up to 150 feet line-of-sight. Both transmitter and receiver are crystal controlled for stable operation. The matched receiver has a single-ended audio output that plugs right into an existing PA system or other amplifier.

## BODY-PAC WIRELESS MICROPHONE SYSTEMS

SYSTEM	49MHz CAT. NO.	150-174MHz CAT. NO.	174-216MHz CAT. NO.	400-470MHz CAT. NO.	PRO NET
22		3501-01	3501-02		\$1,945.00
22E		3524-01	3524-02		\$2,195.00
24E				3536-01	\$2,925.00
22F		3501-11	3501-12		\$1,925.00
22EF		3524-11	3524-12		\$2,095.00
24EF				3536-11	\$2,825.00
22R		3501-21	3501-22		\$1,320.00
42M		3515-01			\$1,085.00
42C		3515-03			\$1,015.00
64E	3533-01				\$ 715.00

Prices and Specifications Subject to Change Without Notice.

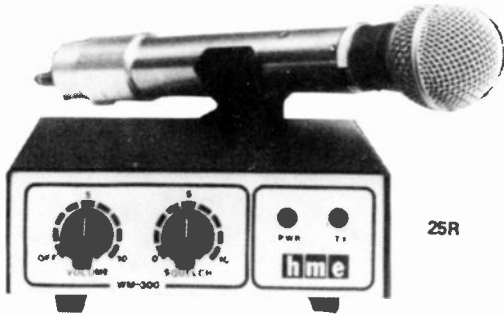

### HAND-HELD SYSTEM WIRELESS MICROPHONE SYSTEMS

#### SYSTEM 25 - COMPRESSOR/LIMITER MAKES MIXING EASY

HME's "soft compressor" is built into this microphone for superb sound quality from soft to loud passages. The levelled output is easy to match without difficult mixing. Styled with a satin finish housing and capped with an ultra-short antenna, the transmitter uses your choice of a Shure SM57 or SM58 element.

The receiver is the same as that used on the System 22.

#### SYSTEM 25E - WITH DYNAMIC EXPANSION

The System 25E can be used interchangeably by singers with soft voices and high-level rock vocalists— without adjustment.

The hand-held transmitter includes a Shure SM57 or SM58 head, especially good for close-up work. An ordinary 9-volt alkaline battery powers the unit for 8 hours, and can be changed in 10 seconds. VHF Hi-band design and crystal control assures interference-free and drift-free operation up to 500 ft. in line-of-sight applications, or 100 ft. in adverse conditions.

The receiver is the same as that used in the System 22E, with Dynamic Expansion, balanced outputs plus separate monitor amp.

#### SYSTEM 27 E - PROFESSIONAL UHF LO-BAND (400 - 470 MHz) HAND-HELD WIRELESS MICROPHONE SYSTEM

HME's "studio quality" Hand-Held Microphone System is now available on UHF Lo-Band frequencies. The same superb audio qualities characteristic of HME's VHF Systems are designed into the UHF System. For example, HME Systems use the FM (frequency modulation) transmission method in the UHF band, plus an audio processing technique called Dynamic Expansion. By using HME Dynamic Expansion, the System 27E reproduces the input signal linearly up to 95 dB and the balanced audio output. In other words, System 27E sounds exactly like a cabled SM 58 Microphone. There are no audio gain adjustments required on the transmitter.

The System 27E consists of a Hand-Held Transmitter and a Receiver. The transmitter is 27 cm (10 1/2 inches) long and contains all the electronics in the barrel portion. The receiver is simple to operate and comes equipped with ship antenna. The receiver can also be battery operated. Balanced audio output is provided at either MIC OR "LINE" level.

#### SYSTEM 25F - FLAT PAC CONVENIENCE

The WM-155 receiver in this system offers transformer-coupled outputs, battery operation, stable crystal-controlled operation with Autolock AFC. It may be powered directly from a Nagra recorder, for example, to make a perfect combination for remote interviewing. The hand-held transmitter uses the compressor/limiter function of the System 25.

#### SYSTEM 25EF - WITH FLAT PAC RECEIVER AND DYNAMIC EXPANSION

HME's new Flat Pac is a perfect receiver for remote work. The 25EF uses the same hand-held transmitter as the 25E but includes the WM-152 battery-operated Dynamic Expansion receiver.

**SYSTEM 25R - THE ECONOMICAL SYSTEM WITH PROFESSIONAL SOUND**  
The System 25R is the answer to performers' requests for simple, affordable wireless sound. A professional hand-held transmitter with compressor/limiter is coupled with the System 42's Executive receiver, offering easy, single-ended connection to any PA system or entertainment amp. Plenty of dynamic range for singers and speakers. Up to four systems can be used simultaneously.

### HAND HELD WIRELESS MICROPHONE SYSTEMS

SYSTEM		150-174MHz CATALOG NO.	174-216MHz CATALOG NO.	400-470MHz CATALOG NO.	PRO NET
25	(SM-58) (SM-57)	3514-01 3514-03	3514-02 3514-04		\$2,075.00
25E	(SM-58) (SM-57)	3528-01 3528-03	3528-02 3528-04		\$2,325.00
27E	(SM-58) (SM-57)			3535-01 3535-03	\$3,075.00
25F	(SM-58) (SM-57)	3514-11 3514-13	3514-12 3514-14		\$2,065.00
25EF	(SM-58) (SM-57)	3528-11 3528-13	3528-12 3528-14		\$2,220.00
27EF	(SM-58) (SM-57)			3535-11 3535-13	\$2,975.00
25R	(SM-58) (SM-57)	3514-21 3514-23	3514-22 3514-24		\$1,455.00

### TRANSMITTERS

MODEL NO.	CATALOG NO.	PRO NET
WM 222	3524-81	\$ 860.00
WM 222-TV	3524-82	\$ 860.00
WM 225A	3501-83	\$ 755.00
WM 225A-TV	3501-84	\$ 755.00
WM 242	3534-81	\$1,155.00
WM250 (SM-58)	3514-81	
(SM-57)	3514-83	\$ 890.00
WM 250-TV (SM-58)	3514-82	
(SM-57)	3514-84	\$ 890.00
WM 252 (SM-58)	3528-81	
(SM-57)	3528-83	\$ 990.00
WM 252-TV (SM-58)	3528-82	
(SM-57)	3528-84	\$ 990.00
WM 262 (SM-58)	3535-81	
(SM-57)	3535-83	\$1,305.00
WM 400C	3515-83	\$ 450.00
WM 400M	3515-81	\$ 525.00
WM 640	3533-81	\$ 340.00

### RECEIVERS

MODEL NO.	CATALOG NO.	PRO NET
WM 122	3525-01	\$1,295.00
WM 125	3502-01	\$1,145.00
WM 142	3536-02	\$1,733.00
WM 152	3529-02	\$1,195.00
WM 155	3529-01	\$1,130.00
WM 172	3540-02	\$1,630.00
WM 300	3516-01	\$ 560.00
WM 540	3532-01	\$ 375.00

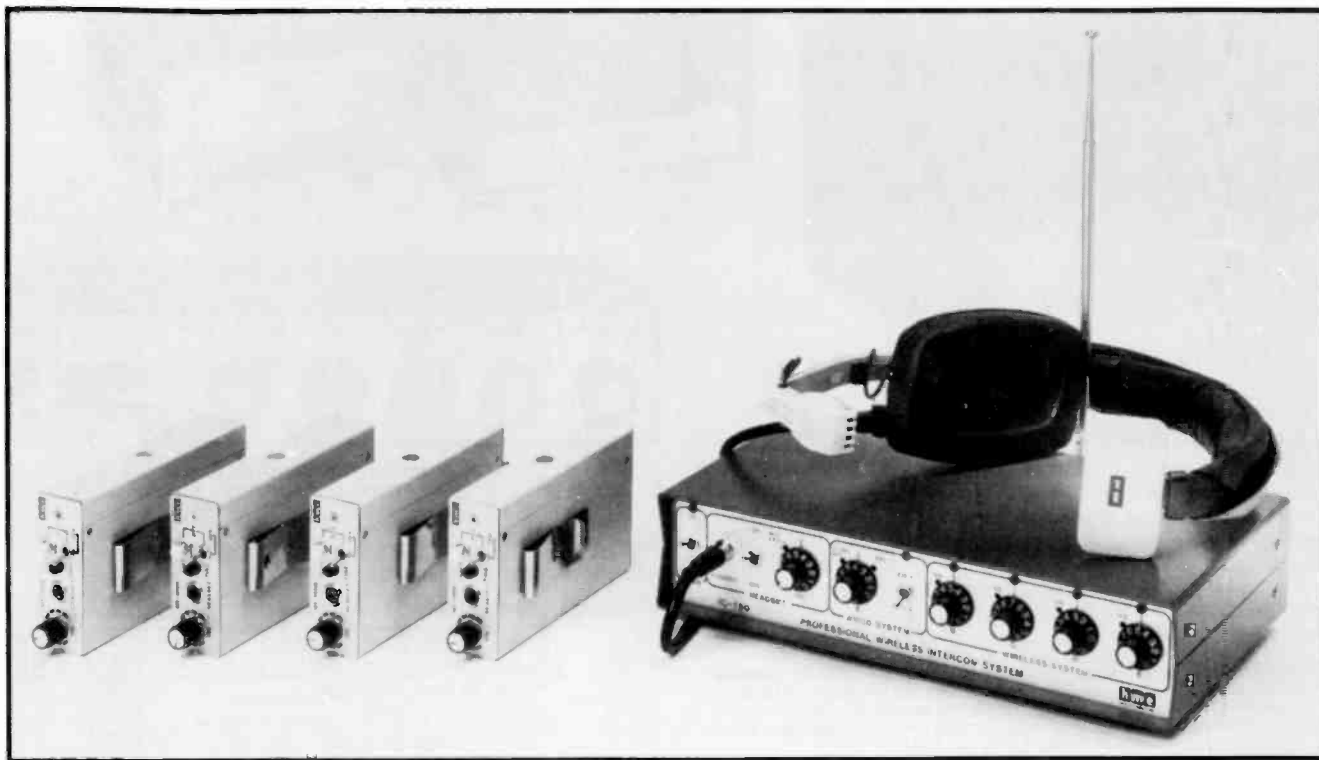

### 150E Series Wireless Intercom System

- **Full-Duplex Operation** — Provides continuous hands-free intercommunication between the base station and as many as four remotes.
- **Push-to-Talk Operation** — Unlimited number of remotes may be used for push-to-talk communication.
- **Hard-Wired System Interface** — Provides for expanding almost any hard-wired intercom system to include full-duplex or push-to-talk wireless stations. Full inter-system level control.
- **Ultra Compact Remote Transceivers** — Single unit, metal enclosed, belt transceivers are only 5-1/2" x 3-1/4" x 1-1/8" small and 10 oz. light.
- **Only 1 VHF High Band Channel Required** — To conserve available wireless microphone channels, the remote transceivers transmit in the VHF Mid-band. The base station uses only one channel in the VHF Hi-band.
- **HME Dynamic Expansion** — Assures clean, noise-free operation with a dynamic range of at least 80 dB.
- **Integrated Base Station** — Compact, convenient base station contains all functions and controls as supplied, including one receiver module. For added full-duplex stations, additional receiver modules are simply plugged in as needed.
- **Loop-Around Sidetone** — Presence of clear sidetone verifies communications, since transmissions from each remote are re-broadcast by the base station as received.
- **Headset/Microphone** — Supplied with each station (Beyer DT 108).

The need for reliable, hands-free high quality communication between several people is obvious and diverse. The HME 150E Series is ideally suited to many of these needs.

The IC-150 Base Station is the hub of the system, combining the functions of base transmitter and receiver(s), wired system interface and control center in one compact unit. It transmits to each MT-1000 remote unit on a single VHF Hi-band frequency. It also receives the VHF Mid-band transmission from the remote units. The received signal(s) is simultaneously fed to the base operator's headset, to the wired system interface and to the transmitter section for rebroadcast to each remote unit.

The MT-1000 remote transceivers receive the base operator's message on the VHF Hi-band channel, and transmit messages to base (and subsequently to any other MT-1000) on a VHF Mid-band frequency. In full-duplex operation, each MT-1000 uses its own transmit frequency (the IC-150 will receive up to four different frequencies). In push-to-talk operation, all MT-1000's may use the same transmit frequency. Operator side-tone is provided through rebroadcast of the receive signal by the IC-150, automatically confirming receipt of communication.

#### IC-150 BASE STATION

##### Specifications

- **Audio Frequency Response:** 300 Hz-3 KHz
- **Operating Frequencies:**  
Transmit: 150-174 MHz (One channel)  
Receive: 26.1-26.48, 30-35 or 72-76 MHz (up to four channels in any one band)
- **Dynamic Range:** Greater than 80 dB
- **Distortion:** Less than 3%
- **Transmit Power:** 100mW
- **Receiver Sensitivity:** 1uV for 20 dB quieting
- **Wired System Interface:**  
Level: — 3 volts (adjustable)  
Impedance: 200 ohms
- **Power Requirement:** 115V/50-60 Hz or Ext 12-30 VDC
- **Size:** 11" x 6" x 2-1/2"
- **Weight:** 3-1/2 lbs.

#### MT-1000 REMOTE TRANSCIVER

##### Specifications

- **Audio Frequency Response:** 300 Hz-3 KHz
- **Operating Frequencies:**  
Transmit: 26.1-26.48, 30-35 or 72-76 MHz  
Receive: 150-174 MHz
- **Dynamic Range:** Greater than 80 dB
- **Distortion:** Less than 3%
- **Transmit Power:** 75 mW
- **Receiver Sensitivity:** 1 UV for 20 dB quieting
- **Power Requirement:** 2 x 9 Volt Alkaline (8-10 hours continuous)
- **Size:** 5-1/2" x 3-1/4" x 1-1/8"
- **Weight:** 13 oz. (with batteries)
- **Mounting:** Belt clip

#### AM-150 TRANSMIT/RECEIVE ANTENNA MATCHING SYSTEM

In adverse environments, it may be advantageous to place the IC-150 Antenna in an elevated or distant position. The AM-150 TRAM System matches a single antenna to standard 50 ohm coaxial cable at both transmit and receive frequencies to permit remote placement.

#### RM-150 RECEIVER MODULE

The IC-150 is normally supplied with one receive channel, providing for one full-duplex remote or any number of push-to-talks. An additional RM-150 must be inserted for each additional full-duplex station required (up to 4 total).

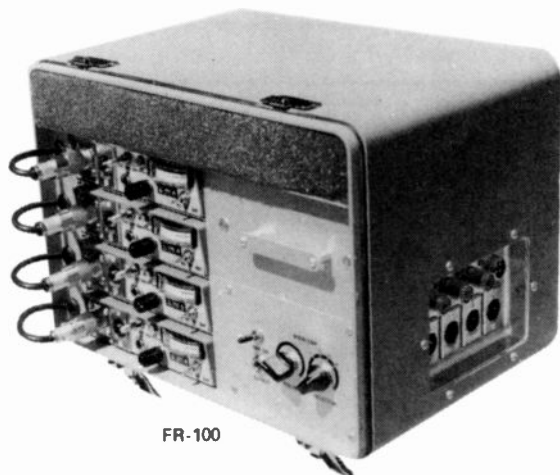

FR-100



AD-10

AD-5

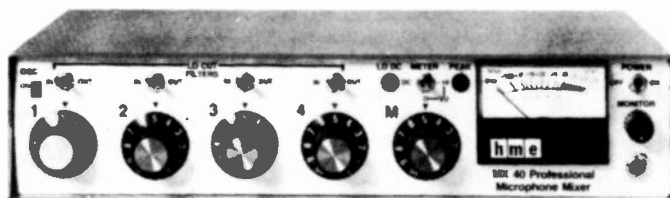

MODEL MX-40 PROFESSIONAL FOUR-CHANNEL MICROPHONE MIXER

### WIRELESS MICROPHONE SYSTEM ACCESSORIES

- Three-level input selection on all four "MIC" inputs (-55, -40 line)
- Dual output, balanced "MIC" and "LINE"
- Color coordinated knobs for convenient MIC identification
- Ultra-low noise and distortion
- Low distortion tone oscillator
- LED INDICATORS FOR AUDIO PEAKS AND BATTERY CONDITION
- Isolated mix bus inputs/outputs for cascading units
- Portable — AC or battery operated

The MX-40 Professional Microphone Mixer was designed primarily for portable applications where size, weight, and rugged construction are important, in addition to reliable, studio-quality audio performance. The wide variety of options available for powering the MX-40 are 115/230V ac, and dc from 10 to 35 volts (two 9-volt alkaline batteries can easily power the unit for almost 4 hrs.).

Careful allocation of gain and headroom within the circuit results in maximum dynamic range achieved under a large variety of operating conditions. Input level selectors on each channel raise the headroom for "hot" microphones without the noise sacrifice of an input pad.

The ultra-low noise floor eliminates ac hum and other residual noise even at the most critical input levels. Distortion is typically less than 0.05% THD measured at 1 kHz.

A convenient front-panel headphone monitor is totally isolated from the line and microphone outputs, and has a separate volume control.

### FR-100 FIELD PAC RECEIVER CASE

Convenience, versatility and protection are features of the FR-100 Field Pac. Storage space for transmitters, as well as provision for a small four channel mixer, complete the package for the pro audioman in the field. Quick set-up and interface with Nagras, video cameras, etc. are valuable benefits. Accepts up to 4 Flat Pac Receivers. Integral AD-10 Antenna Diversity System with external antenna inputs (less antennas and cables). Internal battery supply (D cells) with battery status LED. Four external audio output connectors. Headphone monitor output jack with input selector and level control. External DC input connector. Receivers readily removable. Transmitter storage in cover. Rugged aluminum case. **\$995.00**

### PROFESSIONAL AUDIO MIXERS

MODEL NO.	DESCRIPTION	CATALOG NO.	PRO NET
MX-40	4-Channel Mixer	3701-01	\$1,080.00

### ANTENNA DIVERSITY SYSTEMS

**AD-5** The HME AD-5 Triple Antenna Diversity System prevents dropouts in a single-channel VHF Hi-Band wireless microphone. It requires three HME Model AN-10 dipole antennas.

**AD-10** The HME AD-10 System operates the same as the AD-5 but provides dropout protection for up to four receivers on different frequencies. Three dipole antennas are also required.

MODEL NO.	DESCRIPTION	CATALOG NO.	PRO NET
AD-5	VHF, one channel, Complete w/Antennas, Cables Less Antennas, Cables	3521-01 3521-81	\$ 565.00 \$ 320.00
AD-10	VHF, four channels, Complete w/Antennas, Cables Less Antennas, Cables	3512-01 3512-81	\$ 695.00 \$ 450.00
AD-15	UHF, one channel, Complete w/Antennas, Cables Less Antennas, Cables	3521-10 3521-90	\$ 565.00 \$ 320.00
AD-20	UHF, four channels, Complete w/Antennas, Cables Less Antennas, Cables	3512-10 3512-90	\$ 695.00 \$ 450.00

### ANTENNAS AND ANTENNA CABLES

MODEL NO.	DESCRIPTION	CATALOG NO.	PRO NET
AN-10	Rx Ant. Hi-Band Dipole, w/Cable	3518-01	\$ 82.50
AN-20	Rx Ant. UHF Dipole, w/Cable	3518-10	\$ 82.50
101001	Rx Ant. Lo-Band, Telescope	3518-08	\$ 13.50
101003	Rx Ant. Hi-Band, Whip	3518-05	\$ 18.00
101007	Tx Ant. Hi-Band, Hand-Held	3518-09	\$ 31.50
101008	Tx Ant. Hi-Band, Flex, w/microplug	3518-07	\$ 22.50
101009	Rx Ant. Whip	3518-13	\$ 18.00
101010	Tx Ant. Flex, w/microplug	3518-14	\$ 22.50
101011	Tx Ant. Hand-Held	3518-15	\$ 31.50
115001	Coax Cable, 25', UHF Conn.	3518-10	\$ 54.00
115002	Coax Cable, 6', UHF Conn.	3518-12	\$ 45.00

### MICROPHONES

MODEL NO.	DESCRIPTION	CATALOG NO.	PRO NET
CE-10	Electret, lapel, w/microplug	3505-21	\$ 157.50
CO-90	Electret, lapel, w/microplug	3505-31	\$ 135.00
ECM-150	Electret, lapel, w/microplug	3505-01	\$ 124.50
EM-10	Electret, lapel, w/microplug	3505-12	\$ 45.00
SM-11	Dynamic, lapel, w/microplug	3505-41	\$ 135.00

### BATTERY PACS for WM 122 or WM 125

MODEL NO.	DESCRIPTION	CATALOG NO.	PRO NET
BP-2	2 Hr. Rechargeable (w/o Batt) (w/Batt)	3522-01 3522-02	\$ 42.00 \$ 78.00
BP-6	6 Hr. 9V Batteries (w/o Batt)	3522-11	\$ 36.00
BP-70	70 Hr. "C" Cells (w/o Batt) (w/Batt)	3522-31 3522-32	\$ 54.00 \$ 90.00

### MISCELLANEOUS

MODEL NO.	DESCRIPTION	CATALOG NO.	PRO NET
AC-5	AC power adaptor		\$ 37.50
BC-5	Belt Clip (less installation)		\$ 3.75
FL-30	Hi-Band Filter		\$ 150.00
FL-40	UHF Filter		\$ 150.00
MA-5	Mic Cable XL (A3F) To Microplug		\$ 45.00
MC-15	Mic Clamp		\$ 19.50
RC-5	Road case (small)		\$ 45.00
RC-10	Road case (large)		\$ 165.00
RP-120-2	19" Rack panel for 2 each, WM 122, 125, or 142		\$ 112.50
RP-120-1	19" Rack panel for 1 each, WM 122, 125, or 142		\$ 97.50
RP-300-2	19" Rack panel for 2 each, WM 300		\$ 112.50
RP-300-1	19" Rack panel for 1 each, WM 300		\$ 97.50
RR-4	Four receiver enclosure		\$ 477.00
760018	Shure A 95 J Balance Transformer		\$ 36.00
	INSTRUCTION MANUAL		\$ 30.00
	MAINTENANCE MANUAL		\$ 60.00



# VIDEO PRODUCTION SWITCHER

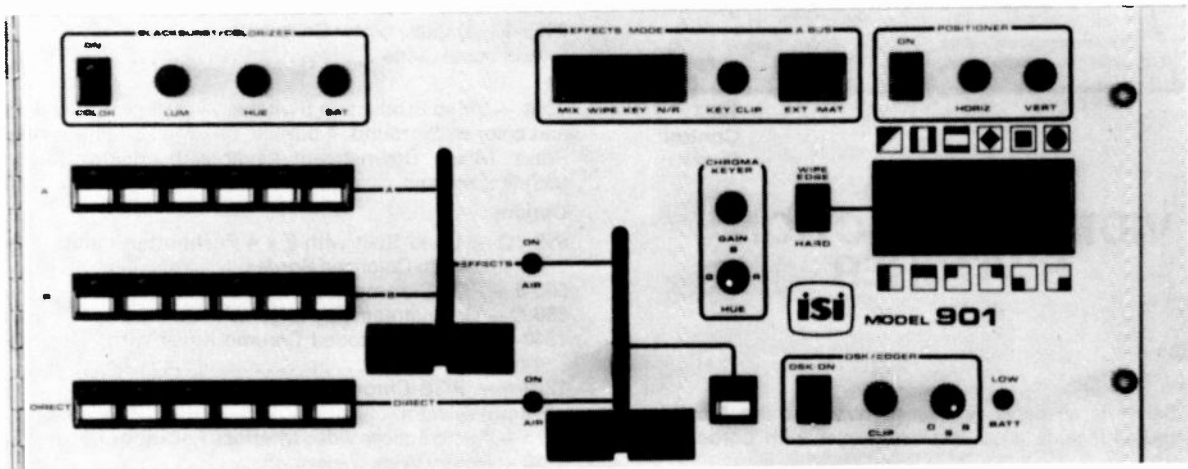

## MODEL 901

### Features:

- 3 Input Busses (A, B, and Direct)
- 6 Composite Video Inputs including, Colorizer/Black
- Mix, Wipe, Key, Mix-Key, Wipe-Key, Mix Wipe-Key
- Hard or Soft Wipes
- Normal/Reverse Wipes
- 12 Patterns
- Positioner
- Operates on AC or DC
- Master Fade to Black

Additional features include a blackburst/colorizer to provide color matte background and color matte fill for video keys. LED's are provided as a convenience, indicating which bus is "on air". A low voltage indicator warning when the +12 V supply is low in the DC mode is standard.

### Specifications:

**INPUTS:** Video Input Level: 1 v p-p composite • Pulse: 4 v p-p +/-6 dB • Subcarrier: 2 v p-p +/-6 dB • Impedance: Video -75 ohm terminated • Pulse - looping • Key - 75 ohm terminated

**OUTPUTS:** Return Loss: greater than 36 dB at 5 MHz • Types: 2 Program, 2 Black Burst • Level: 1 v p-p nominal

**MIX/EFFECTS CHARACTERISTICS:** Black Balance Stability: +/-50 MHz • Switching Transients: Less than 5 IRE • Mix Tracking:

2% • Key Response: Linear

**OVERALL SYSTEMS NTSC (PAL):** Differential Gain: Less than 1.5% • Differential Phase: Less than 1.5° • K Factor—2T Pulse: 1% • Freq. Response (ref 1 MHz): to 6 MHz + .2 dB • Chroma/Lumiance: Less than 10 ns • Crosstalk: Less than 45 dB • Path Delay Accuracy: 1° • Signal/Noise Ratio: Greater than 60 dB • Tilt (Line or Field): Less than 1%

**POWER/TALLY/CABLES (PAL):** Battery: 12VDC • Mains: 120 VAC at 60 Hz (220 VAC +/-10% at 50 Hz) • Power Consumption: 50 W • Tally Relays: Reed Form "A" • Cables: 25 ft. (7.6 m)

**MECHANICAL/ENVIRONMENTALS (PAL):** Connectors: BNC • Control Panel Dimensions: 19 x 7 x 7 (48.26 x 17.78 x 17.78 cm) • Approximate Shipping Weight: 20 lbs. (9.07 kg) • Temperature Range: 0-50°C • Relative Humidity: 95%

AVAILABLE IN NTSC OR PAL

**\$2850.00**

### Options:

- Model 993 Downstream Key Edger (prewired) **\$1680.00**
- Model 994 RGB Chroma Keyer (prewired) **1010.00**
- Model 995 NTSC Encoded Chroma Keyer (prewired) **2240.00**
- Model 959 Sync Generator **590.00**

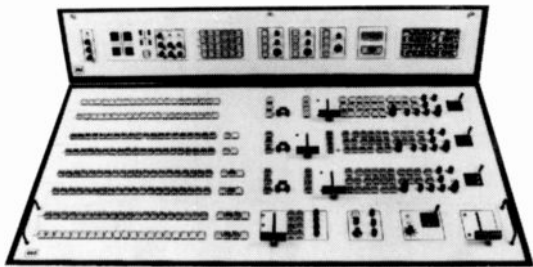

• 1208  
Control  
Panel

## VIDEO PRODUCTION SWITCHER

### 1200 Series

#### Features:

ISI's 1200 Series is available with one, two or three Mix/Effects Amplifiers and all include a downstream keyer with border edging and color.

Each M/E is a two level processor, allowing a mix, wipe or key plus an additional title key with color and border edging.

#### Features:

- Each 1200 Series Video Production Switcher has at least one 1250 M/E Amplifier, which affords the user an enormous amount of creative flexibility by providing the following standard features:
- Pushbutton and assign effects system with LED readout of selected pattern
- "A" and "B" blanking indicators
- Individual M/E colorizer; manual fader operation or auto transition rate; selectable and variable hard, soft, and bordered edges with color; wipe direction selector
- Mix, Key, Wipe, Mix Key, Wipe Key, plus ISI's special Fade Through Black mode (using synchronous or non-synchronous sources)
- Mix or Wipe to preset pattern limits or mask key
- Electronic spotlight with variable 0-100% video level attenuation
- 4 x 2 key source switcher; key fill selector
- Mask key, key invert, and matte key, pull to preview, key preview function
- Dual or "tandem" keying with a primary key (luminance or chroma) followed by a secondary downstream key with outline, shadow, or border and color
- Edging of primary key video for special effects
- Sine wave, square wave or sawtooth modulation with frequency, amplitude, and freeze controls
- Pattern rotate allowing wipe direction and angle to be changed
- Joystick positioner and positioning of multiple repeat patterns to change pattern size
- These features, and their layout, make each 1250 M/E System both flexible and easy to use. Multiple M/E systems arranged in "cascade" fashion, coupled with available mix keyers and options, make the 1200 series the ideal choice where state-of-the-art production switchers are required.

**Note:** Numerous options are available with any 1200 series system and with appropriate 501/505 Rack Frame/Power Supply may be added to most other ISI Production or Master Control Switchers. These options may also be added to other non-ISI equipment depending upon the specifications of that equipment.

**1201** — Video Production Switcher — 12 inputs including black and color background; 4 busses; one Mix-Effects system; one Mix Keyer, 25' control cable; technical manual ..... **\$16,500.00**

#### Options:

- 659-1C** — Quad Split with 6 x 4 Pushbutton Input  
Selector with Colorized Border ..... **\$3250.00**
- 660-4** — RGB Chroma Keyer with 4 Input Selector ..... **1680.00**
- 666-C** — Downstream Key Edger with Colorizer ..... **2075.00**
- 1240-4** — NTSC Encoded Chroma Keyer with  
4 input selector ..... **2635.00**
- 1242-4** — RGB Chroma Keyer with Shadow and  
4 input selector ..... **2075.00**
- 1280** — Rotary Wipe Generator ..... **1795.00**
- 2065-1** — Digital Pointer Generator ..... **1050.00**  
Additional Cable ..... **25.00/ft.**

**1204** — Video Production Switcher — 20 inputs including color black and color background, 4 busses; one Mix/Effects system; Program/Preset Mixer, Downstream Keyer with edging, 50' control cable; technical manual ..... **\$27,400.00**

#### Options:

- 659-1C** — Quad Split with 6 x 4 Pushbutton Input  
Selector with Colorized Border ..... **\$3250.00**
- 660-4** — RGB Chroma Keyer with 4 Input Selector ..... **1680.00**
- 666-C** — Downstream Key Edger with Colorizer ..... **2075.00**
- 1240-4** — NTSC Encoded Chroma Keyer with  
4 input selector ..... **2635.00**
- 1242-4** — RGB Chroma Keyer with Shadow and  
4 input selector ..... **2075.00**
- 1276** — Audio Follow Video Interface Package ..... **4000.00**
- 1280** — Rotary Wipe Generator ..... **1795.00**
- 2065-1** — Digital Pointer Generator ..... **1050.00**  
Automated Production Effects (APE) ..... **18,500.00**  
Additional Cable ..... **25.00/ft.**

**1206** — Video Production Switcher — 20 inputs including color black and color background; 6 busses; two Mix/Effects systems, Program/Preset Mixer, Downstream Keyer with edging, 50' control cable; technical manual ..... **\$44,750.00**

#### Options:

- 659-1C** — Quad Split with 6 x 4 Pushbutton Input Selector with  
Colorized Border ..... **\$3250.00**
- 660-6** — RGB Chroma Keyer with 6 Input Selector ..... **1680.00**
- 666-C** — Key Edger with Colorizer ..... **2075.00**
- 1240-4** — NTSC Encoded Chroma Keyer with  
4 input selector ..... **2635.00**
- 1242-4** — RGB Chroma Keyer with Shadow ..... **1400.00**
- 1276** — Audio Follow Video Interface Package ..... **4000.00**
- 1280** — Rotary Wipe Generator (per M/E) ..... **1795.00**
- 2065-1** — Digital Pointer Generator ..... **1050.00**  
Automated Production Effects (APE) ..... **23,800.00**  
Additional Cable ..... **25.00/ft.**

**1208** — Video Production Switcher — 20 inputs including color black and color background; 8 busses; three Mix/Effects systems, Program/Preset Mixer, Downstream Keyer with edging, 50' control cable; technical manual ..... **\$59,750.00**

#### Options:

- 659-2C** — Quad Split with 10 x 4 Thumbwheel Input  
Selector, 'Take' Pushbutton LED Quadrant Read-  
out with Colorized Border ..... **\$4710.00**
- 660-4** — RGB Chroma Keyer with 4 Input Selector ..... **1680.00**
- 666-C** — Key Edger with Colorizer ..... **2075.00**
- 1240-4** — NTSC Encoded Chroma Keyer with  
4 input selector ..... **2635.00**
- 1242-4** — RGB Chroma Keyer with Shadow and  
4 input selector ..... **2075.00**
- 1276** — Audio Follow Video Interface Package ..... **4000.00**
- 1280** — Rotary Wipe Generator (per M/E) ..... **1795.00**
- 2065-1** — Digital Pointer Generator ..... **1050.00**  
Automated Production Effects (APE) ..... **29,800.00**  
Additional Cable ..... **25.00/ft.**





## VIDEO PRODUCTION SWITCHER

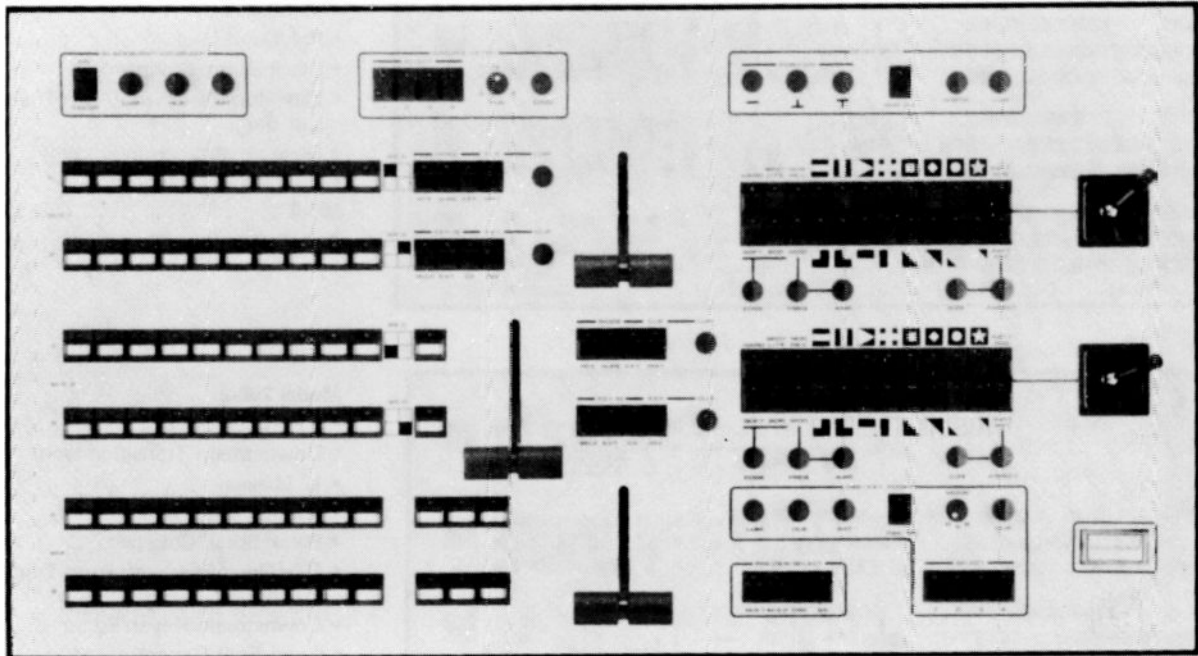

### Model 904 Video Production Switcher

The 904 provides a versatile switching package for complicated studio production, remotes and post production.

Computer editing...digital effects...automation...new technologies placing new demands on production switchers.

The 904 incorporates microprocessor control, effectively interfacing the 904 with the future. Serial editor interface, event storage and total switcher automation are field installable plug-in options.

#### Standard Features

- 10 inputs including Blackburst/Colorizer
- 6 busses
- 2 independent Mix/Effects units
- Program/Preset mixer
- DSK with key edging and 4 input selector
- Master fade to black
- Pulse processor
- Full camera tally system
- Microprocessor controlled
- Single 25' cable to remote control panel
- Technical manual
- Two year warranty

The 904 mix/effects systems are unequalled in capabilities and ease of operation. The last technical advances have been incorporated into the new pattern generators, providing crisp hard wipes and variable soft or bordered wipe transitions. Included in the 16 patterns are a star and 3 rotary wipes. Pattern preset allows control of both the preset limit and pattern aspect ratio and can be used to either mix or wipe to a preset pattern or masked key.

Each mix/effects system includes the following standard features:

- Mix, wipe, key, mix key and wipe key modes
- 16 pattern generator with 3 rotary patterns and star
- Pattern normal/reverse
- Variable soft or border and hard pattern transitions
- Pattern positioner
- Pattern preset with separate size and aspect controls
- Pattern modulation with frequency and amplitude controls
- Pattern spotlight
- Self, chroma key and external key inputs
- Matt key
- Key invert

\$16,400.00



# VIDEO PRODUCTION SWITCHER

## 200 SERIES

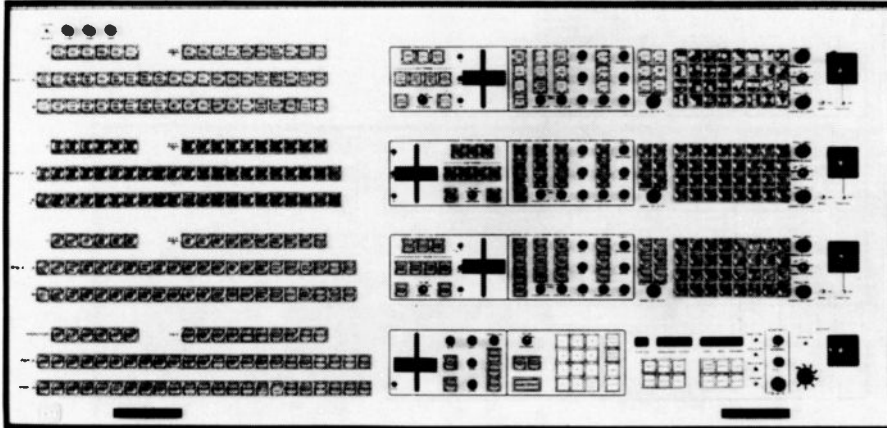

### Model 200-3

- 3 PolyKey Effects Units
- Downstream Transition Unit
- 15 busses
- PolyKey Effects
- Black Burst/Colorizer
- Flip/Flop Mixer with Auto Transitions and Cut Bar
- Downstream Keyer/Edger
- Quad Split Generator

200-3 .....\$102,000.00  
 A.P. E. Option .....29,800.00

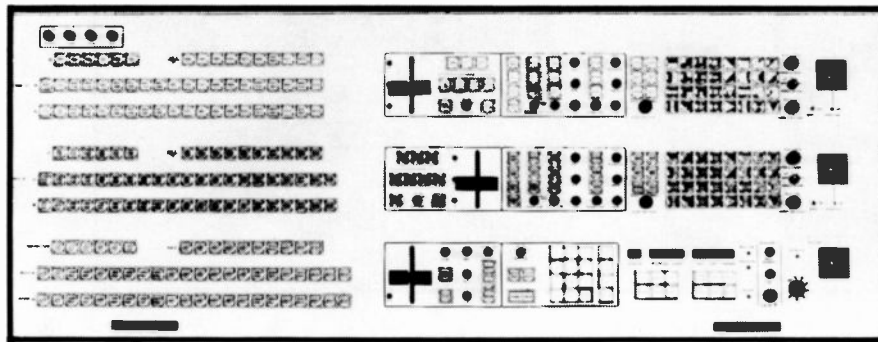

### Model 200-2

- 2 PolyKey Effects Units
- Downstream Transition Unit
- 12 busses
- PolyKey Effects
- Black Burst/Colorizer
- Flip/Flop Mixer with Auto Transitions and Cut Bar
- Downstream Keyer/Edger
- Quad Split Generator

200-2 .....\$76,800.00  
 A.P.E. Option .....23,800.00

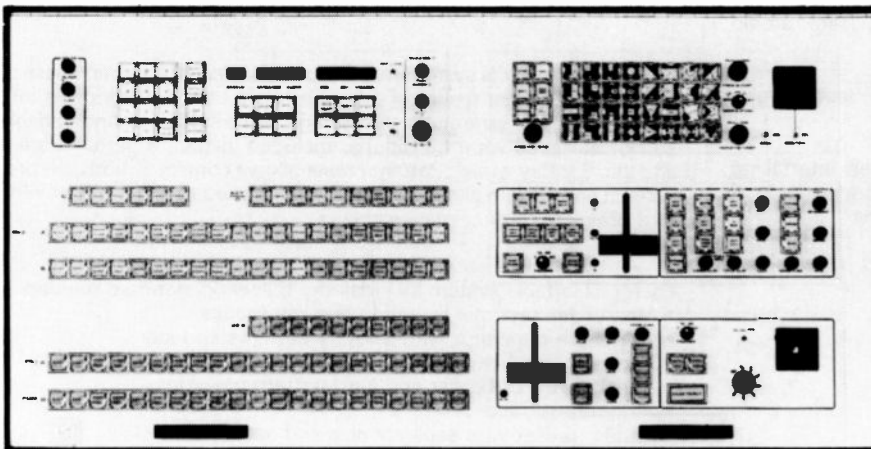

### Model 200-1

- 1 PolyKey Effects Unit
- Downstream Transition Unit
- 8 busses
- PolyKey Effects
- Black Burst/Colorizer
- Flip/Flop Mixer with Auto Transitions and Cut Bar
- Downstream Keyer/Edger
- Quad Split Generator

200-1 .....\$51,500.00  
 A.P.E. Option .....18,500.00

### 200 SERIES FEATURES:

The 200 Series is an advanced, state-of-the art production switching system, offering one, two or three PolyKey Effects (PKE) Systems.

Each PKE has a 4 level processor with the following features:

- 4 input busses
- Manual or auto transitions
- Video key plus title key over/under
- Black/white/color border edging

- Chroma key standard
- Rotary and spin wipes

Every 200 Series switcher also has a Downstream Transition Unit which includes:

- 'Flip-flop' mixer with cut bar
- Fade-to-black with pulse processing
- DSK with border edging and color
- Pointer Generator

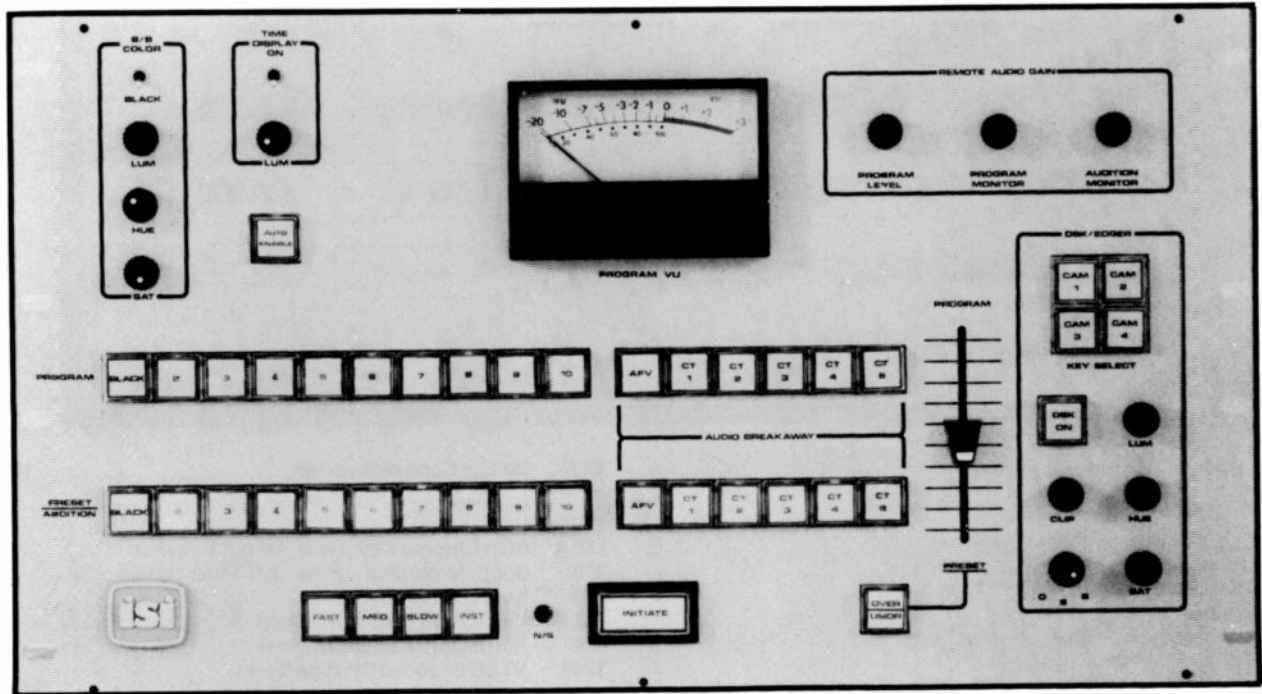

# MASTER CONTROL SWITCHER

## Model 931

### Features:

- Ten (10) inputs including black burst/colorizer, audio follow video
- Five (5) audio breakaways
- Audio over/under
- Preselectable audio/video mix transitions at four rates with initiate bar
- Downstream key edger with four input selector, colorizer, and outline, shadow, and border
- Audition monitor, program monitor, and program level controls
- Non-synchronous source detection and inhibit
- Program audio VU meter
- Rack mount configuration
- 25' control cable, technical manual

### Price:

Model 931 .....\$9800.00

### Specifications:

Inputs .....75 ohm terminating  
 Outputs .....two (2), 75 ohms source terminated  
 Crosstalk .....better than -52 dB at 3.58 mHz  
 Differential Gain .....1.5%  
 Differential Phase .....1.5°  
 Input Return Loss .....35 dB minimum  
 Output Return Loss .....35 dB minimum  
 Signal to Noise Ratio .....better than 60 Hz-5 mHz

Frequency Response ..... DC to 8 mHz +/- 0.25 dB  
 Tilt (Line or Field Rate) ..... less than 1%  
 Differential Delay ..... +/- 1.5° at 3.58 or 4.43 mHz  
 K Factor ..... 1% or better (T pulse)  
 Temperature Range .....0-50°C

### Audio Specifications:

Inputs .....0 dBm, + 15 dBm maximum  
 balanced bridging  
 Outputs .....two (2), 600 ohms balanced,  
 15 dBm maximum  
 Harmonic Distortion ..... less than 0.25%, 20 Hz-20 kHz  
 at 0 dBm output  
 Frequency Response ..... +/- 0.1 dB, 10 Hz-30 kHz  
 Crosstalk ..... better than -65 dB  
 Signal to Noise Ratio ..... better than -68 dBm down below  
 + 0 dBm (20 Hz-20 kHz)  
 Input to Output Gain ..... unity +/- 2 dB  
 Connectors ..... post

### Mechanical/Power Specifications:

Power .....120 vac +/- 10% 60 Hz  
 Dimensions ..... 19 x 10 1/2 x 3 1/2 (control panel)  
 19 x 11 x 8 1/4 (electronics)

### Options:

Model 937 Time Display .....\$675.00



# MASTER CONTROL SWITCHER

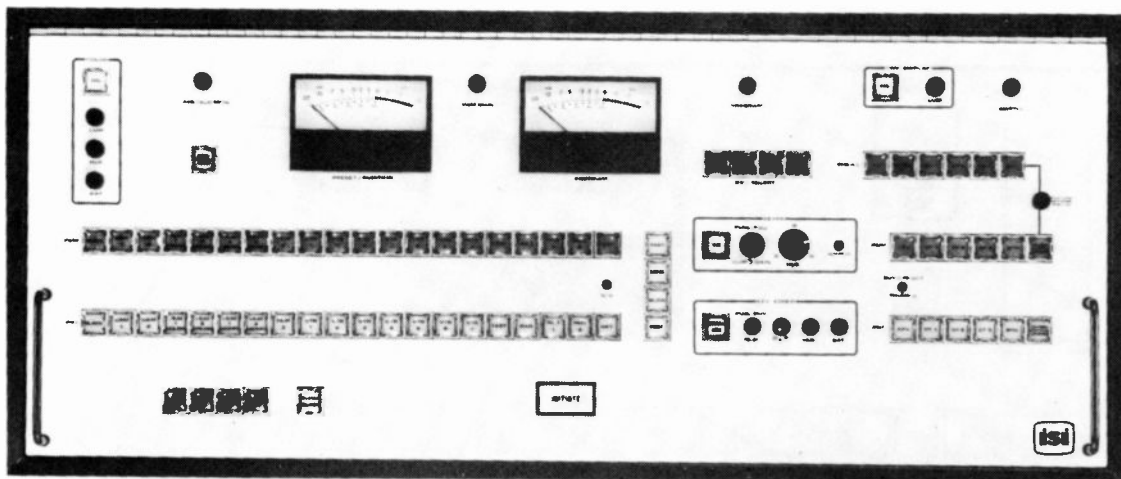

## Model 821

### Features:

- Twenty (20) inputs with full tally
- Colorizer
- Program and preset busses
- BCD control
- Audio/Video mixer with auto transitions
- Four (4) audio breakaways
- Audio over/under with adjustable video
- Program and preset audio VU meters
- Built-in pre-roll system
- Downstream keyer with edging, 4 input selector and colorizer
- Control panel prewired for following options:
  - Chroma Keyer
  - Time Display
  - Booth Mic Pre-amp
- 50' control cable
- Technical manual

### Description:

- ISI's Model 821 Master Control Switcher offers a state-of-the-art means for switching control room signals in television stations, sophisticated cable systems, or other program origination sources.
- The 821 allows the air/program switcher to mix between sources at one of three automatic rates or 'take' a new source instantaneously. Audio follows the video through the mix or cut except when an audio breakaway source is selected. When this occurs new audio (from an audio cart, for example) is substituted for the audio on the selected video source. If breakaway and over/under are both selected, the new audio is mixed with the audio from the video source and may be predominant (over) or background (under). The audio breakaway always returns to the AFV position after the mix.
- A Downstream Keyer with edging allows title keying over the program output of the 821. It includes a four input selector and colorizer.
- Pre-roll circuitry for VTR's, film islands, and other machine sources, is built into the 821. With the addition of the appropriate optional machine decoder modules and buffers, machine pre-roll is activated by engaging the initiate button. The mix takes place after the pre-programmed pre-roll has been completed.
- Other options include a program monitor time display which provides a pre-roll and elapsed time counter and a real-time clock display. An RGB or NTSC Chroma Keyer with 4 inputs selector allows "News Break" inserts without tying up a production switcher. A booth mic pre-amp, full stereo audio operation, and microprocessor automation package, are available options.
- The 821 carries ISI's full two year warranty and board exchange program.

## 821 Master Control Switcher

\$25,225.00

### Options:

660-4	RGB Chroma Keyer with 4 Input Selector	\$1,680.00
710	Booth Microphone Preamp Control	400.00
870	Stereo Audio	8000.00
883	Video Tape Machine Control	510.00
884	Film Island Machine Control	675.00
1240	NTSC Encoded Chroma Keyer	2240.00
	Additional Cable	20.00/ft.

### Video Specifications:

Inputs	75 ohm terminating or bridging (customer option)
Outputs	two (2), 75 ohm source terminated
Crosstalk (worst case)	better than -52 dB at 3.58 or 4.43 MHz
Differential Phase	better than 9.5° (10-90% APL)
Differential Gain	better than 0.5%
Input Return Loss	35 dB minimum
Output Return Loss	35 dB minimum
Signal to Noise Ratio	better than 60 dB to 5 MHz
Frequency Response	DC to 8 MHz +/- 0.25 dB
Tilt (Line or Field Rate)	better than 1%
Differential Delay	+/- 1.5° at 3.58 or 4.43 MHz
K Factor	1% or better (T pulse)
Temperature Range	0-50°C
Connectors	BNC
Power	120 vac +/- 10% 60 Hz

### Audio Specifications:

Inputs	0 dBm, + 15 dBm maximum balanced bridging
Outputs	2-600 ohms balanced 15 dBm maximum
Harmonic Distortion	less than 0.25%, 20 Hz-20 kHz at 0 dBm output
Frequency Response	+/- 1 dB, 10 Hz-30kHz
Crosstalk	better than -65 dB
Signal to Noise Ratio	better than -68 dBm down below +0 dBm 20 Hz-20kHz
Input to Output Gain	unity +/- 2 dB
Connectors	post
Power	120 vac +/- 10% 60 Hz
Dimensions	11 5/8" x 30" (control panel) 12 1/4" x 30 3/8" x 6" (cutout for pan) 19" x 21" x 13" (track electronics)



## VIDEO PRODUCTION SWITCHER

Our PolyKey System has changed switching by adding more production capabilities with easier operation. We didn't revamp an old idea, we advanced the state-of-the-art in television production artistry, with the PolyKey Concept. Every 200 Series switcher is built around it.

The PolyKey Concept began with the realization that today's most exciting production effects are produced using the key mode. Even digital effects units interface through the external key input. Add title and graphics keys, video keys, and effects transitions behind chroma keys, and it's soon evident that to limit keying means limiting production capability.

### PKE AMPLIFIER

The unique PKE amplifier is the heart of every 200 Series Switcher. The following are some of its STANDARD features:

- Independent multi-pattern generator and positioner
- 4 input busses
- Internal quad split and chroma key
- Title key over/under
- Video key
- Black/white/color edging of title and video key
- Frame rate auto transitions
- 3 way modulator with freeze
- Normal/normal-reverse/reverse pattern direction
- Rotary and spin wipes

### DOWNSTREAM TRANSITION UNIT

Our Downstream Transition Unit keeps the production flowing smoothly with the following standard features:

- A "flip-flop" mixer automatically transfers program/preset sources.
- A "cut bar" and auto mix position keep "flip-flop" transitions smooth and exact in any situation.
- A built-in downstream keyer with outline, drop shadow, and border edging and colorizer (fed from a 10 input key bus) allow the insertion of titles and graphics over program material.
- The fade-to-black module also incorporates a new pulse processing system to eliminate the picture shift at the end of the transition. Less than perfect timing is then corrected by the ISI 200. The pulse processor also has outputs available to lock external sources such as character generators.
- Standard in every Downstream Transition Unit is an 8 position pointer generator with "joystick" positioner. This popular feature is widely used in weather reporting and instructional productions.

The PKE unit is divided into four main areas:

- 1) Input busses — A, B, C, D
- 2) Transition modes
- 3) Keying functions
- 4) Wipe effects

- 8 Position Pointer Generator
- 30° Input Phase Adjustment
- Master Fade-to-Black
- Preview Monitor Input Selector
- Pulse Processing

#### Dimensions

200-1	.....	16.250 x 32.625 x 6 (control head) 28 x 19 x 13 (electronics)
200-2	.....	17.00 x 45.875 x 6 (control head) 35 x 19 x 13 (electronics)
200-3	.....	21.50 x 48.875 x 6 (control head) 42 x 19 x 13 (electronics)

### AUTOMATED PRODUCTION EFFECTS UNIT (A.P.E.)

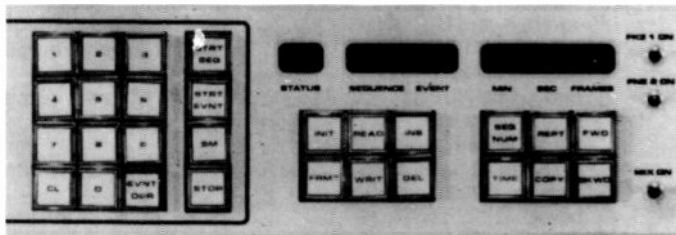

#### A.P.E. PANEL

The A.P.E. (Automated Production Effects) is an event storage and retrieval automation system which is optional.

Our A.P.E. (Automated Production Effects) unit is an easy to operate event storage and retrieval system which allows the director to concentrate on creativity instead of switcher operation. It's easy because all events are learned by manually executing control panel functions, then storing the switcher setup in the A.P.E. memory.

By defining points where switcher setup changes, and programming transition rates, complicated production sequences may be learned and repeated or stored for later use. Our A.P.E. can remember 60 events in its hardware memory and 3840 events in disk storage.

Events represent a single setup for the entire switcher which may include as many as 15 buses and the complete setup of 4 M/E or mix units.

Our A.P.E. can execute transitions with a smooth flow that's not humanly possible. For instance, try moving a circle pattern with the positioner control while expanding the size of the circle. It's virtually impossible to execute that movement smoothly, but, thanks to our A.P.E.'s microprocessor brain it can perform this simple move flawlessly on 3 mix/effects units simultaneously.

#### 200 Series Specifications (Model 200-3):

Inputs	.....	video 75 ohms bridging
Return Loss	.....	greater than 40 dB (T pulse)
Pulse	.....	75 ohms bridging
Return Loss	.....	greater than 40 dB (T pulse)
Input Level Video	.....	1 vpp composite
Pulse	.....	2-8 vpp
Subcarrier	.....	1-4 vpp
Outputs	.....	(2) outputs 75 ohms source terminated
Output Level	.....	1 vpp composite
Response	.....	relative 1 mHz, + /-0.1 dB, DC to 8 mHz, + 0.1 to -2 dB
Switching Time	.....	approximately 1 microsecond (vertical interval)
Differential Phase	.....	less than 1.5° 3.58 or 4.43 mHz (10-90% APL)

Differential Gain	.....	less than 1.5% 10-90% APL
K Factor	.....	less than 1% (T pulse)
Chrominance/Luminance Delay	.....	less than 10 ns
Delay Inequality Chrominance/ Luminance	.....	less than 0.1 dB
Crosstalk (worst case)	.....	greater than -52 dB at 3.58 mHz; -50 dB at 4.43 mHz
Signal to Noise Ratio	.....	greater than 58 dB pp signal/ RMS noise to 5 mHz
Path Length Accuracy	.....	less than 1.5° (3.58 or 4.43 mHz)
Tilt (Line or Field Rate)	.....	less than 1%
Temperature Range	.....	0-50°C
Tally Relay Contacts	.....	2 A-30 v
Power Input	.....	10 v or 20 v, 50-60 Hz + /-10%
Control Cable	.....	.400' maximum

Prices and Specifications Subject to Change Without Notice.

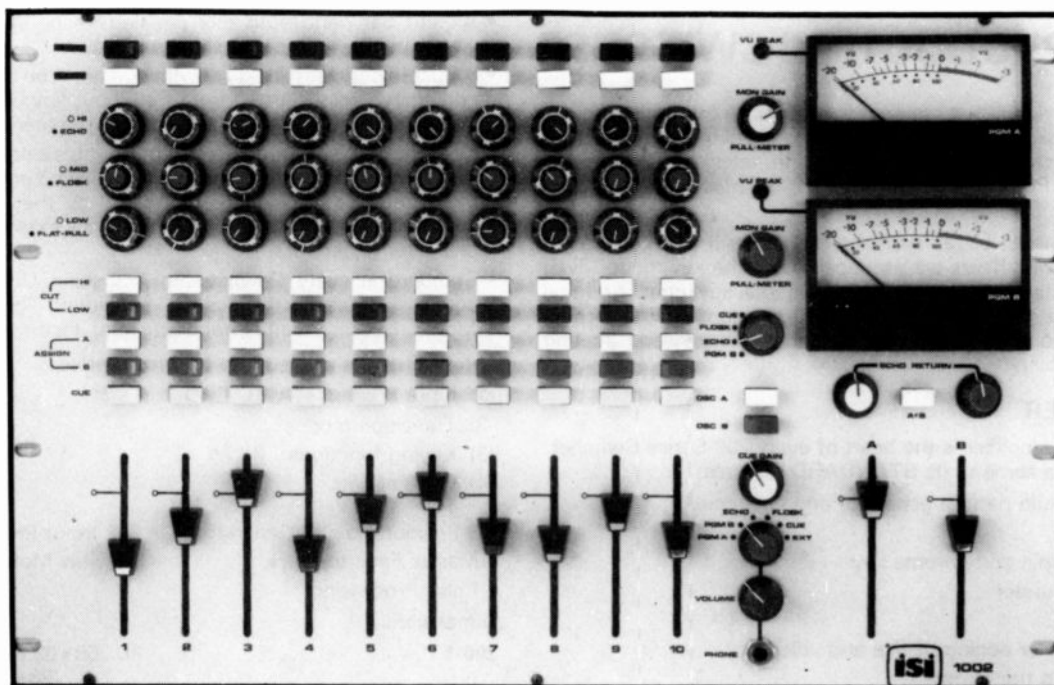

## AUDIO CONSOLE FOR TELEVISION

### Model 1002

#### Features:

- Modular construction
- Ten (10) inputs, two (2) program outputs, fully balanced
- Front panel switchable Hi or Lo level input selectors
- Three (3) foldback/echo send outputs
- Input channels feature three stage equalization and Hi and Lo cut filter Cue and muting capabilities
- Professional-type slide faders and preset gain adjustment
- Input sources may be assigned to either A or B outputs
- Tone oscillator
- Illuminated VU meter and LED peak indicator
- Echo return gain control
- Two (2) monitor outputs with level control
- Optional stereo input and output modules

#### Specifications:

##### Inputs:

Audio ..... ten (10) balanced inputs  
 Microphone ..... input impedance 4000 ohms;  
 source impedance 150/  
 250 ohms; nominal input  
 level -65 dBm; equivalent  
 input noise -123 dBm 10  
 Hz - 10 kHz

Line ..... input impedance 20K;  
 source impedance 600  
 ohms; nominal input  
 level + 4 dBm, equivalent  
 input noise -95 dBm

##### Output:

##### Audio

##### Line level outputs:

Program A and B ..... two (2) 600 ohm outputs  
 Monitor A and B ..... one (1) 600 ohm output  
 Foldback, Echo  
 Send, Cue ..... one (1) 600 ohm output

##### Nominal Output

Level (faders  
 at -12 dB) ..... + 4 dBm  
 Maximum Output  
 Level ..... + 20 dBm

##### Distortion

(20 Hz-20 kHz) ..... 0.5% THD  
 Headphone Output ..... volume adjustable, clipped  
 at + 100 dB sound level

Frequency Response ..... +/-0.5 dB, 20 Hz-20 kHz

Crosstalk ..... 70 dB

Distortion ..... 0.25%, 20 Hz-20 kHz

Equalization ..... lo: 14 dB boost/cut at 60 Hz;  
 mid: 14 dB boost/cut at 2.5 kHz;  
 hi: 14 dB boost/cut at 10 kHz;  
 lo cut: -3 dB at 100 Hz, -12 dB/octave;  
 hi cut: -3 dB at 12 kHz, -12 dB/octave

Calibration Oscillator ..... frequency 1 kHz (+/- 10%)

Connectors ..... input channels 3 pole 180° XLR  
 output channels 3 pole 180° XLR

Dimensions ..... 12 1/4 x 19 x 8 1/4

\$4,575.00



# VIDEO PRODUCTION SWITCHER

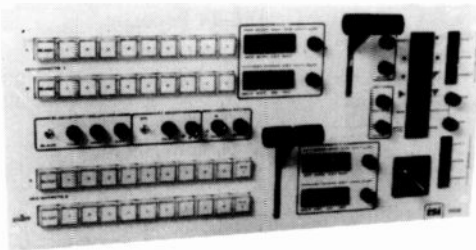

**Model 902**

**Specifications:**

Inputs .....	ten (10) synchronous inputs including black burst
Input Phase Adjustment .....	+ /-10°
Input Level:	
Video .....	1 vpp composite
Pulse .....	.4 vpp +6 dB
Subcarrier .....	.2 vpp +6 dB
Outputs .....	program 2-75 ohms; preview 2-75 ohms; M/E1 "A" 1-75 ohms; M/E1 "B" 1-75 ohms; M/E2 "A" 1-75 ohms
Output Level .....	1 vpp composite
Key Inputs .....	three input for M/E1; three input for M/E2
Crosstalk (worst case) .....	greater than -53 dB at 3.58 MHz
Differential Gain .....	1.5%
Differential Phase .....	1.5°
Hum and Noise .....	60 dB below 1 vpp
Frequency Response .....	8 MHz +0.25 dB
Tilt (Line or Field Rate) .....	less than 1%
Fader Linearity .....	better than 1%
Video and Pulse Connectors .....	BNC
Buttons .....	momentary contact pushbuttons with indicator lamps
Temperature Range .....	0-50°C
Tally Relay Contacts .....	"C" connection on all inputs
Dimensions .....	8 3/4 x 19 x 2 1/2 (control panel) 7 x 19 x 13 (electronics)
Control Cable .....	.25'
Power Required .....	120 vac +/- 10% 50-60 Hz 100 watts

**Features:**

- Rack mount control head with separate 7-inch electronics package
- Ten (10) clamped and phase adjustable inputs including black burst/colorizer
- Momentary contact pushbuttons with indicator lamps
- Full tally on all inputs
- Separate preview and program output switching busses
- Two (2) Mix/Effects systems utilizing ISI's exclusive Shared Pattern Generator
- True reentry effects system
- Pattern Generator includes seven (7) basic patterns plus Rotate position enabling hundreds of standard and special wipes to be created
- Mix/Effects functions include mix, wipe, key mix/wipe and mix or wipe key
- Electronic spotlight, pattern modulator, and "joystick" positioner
- Adjustable hard, soft, and bordered edges, and preset pattern limit
- Professional full-size faders
- Three input key selector, matte key and key invert is standard on each M/E
- 25' control cable
- Technical manual

**Description:**

- With almost 300 Model 902 Video Production Switchers installed and field proven, the 902 has gained remarkable acceptance in the two years since its introduction. This switcher features two (2) Mix/Effects Systems utilizing ISI's exclusive Shared Pattern Generator, multiple keying functions, and extreme flexibility due to the separate preview and program output switching busses.
- Added features, all standard on the 902, such as electronic spotlight, modulator, positioner, and preset pattern limit, plus the ability to do hard, soft, or bordered wipes make the 902 ideal for any small or medium size studio or remote production facility.
- As with all ISI products, the 902 carries a full two year warranty on all parts and labor. **\$6,950.00**

**Options:**

660 - RGB Chroma Keyer (prewired) .....	\$1010.00
666 - Downstream Key Edger (prewired) .....	1680.00
908 - Audio Follow Video Package .....	3500.00
920 - Editor Interface .....	3200.00
1240 - Encoded Chroma Keyer (prewired) .....	2240.00
2031 - Matrix Wipe Generator .....	2230.00
2065-1 - Digital Pointer Generator .....	1050.00
Additional Cable .....	10.00/ft.

## TERMINAL/PROCESSING EQUIPMENT

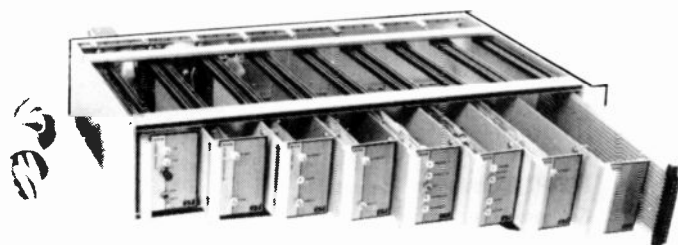

**501 Mainframe**

500 - Blank Cover Plate .....	\$30.00
501 - Rack Frame .....	180.00
503 - Extender Card .....	40.00
505 - Power Supply .....	180.00
508 - Power Supply 220 Volt .....	180.00
513-4 - Video DA-4 Output .....	280.00
513-6 - Video DA-6 Output .....	290.00
515 - Differential Input Video DA .....	350.00
516-4 - Video Equalizing Amplifier with Differential Input (4 Output) .....	380.00
516-6 - Video Equalizing Amplifier with Differential Input (6 Output) .....	390.00

517 - Video Clamp DA .....	365.00
519 - Pulse DA .....	275.00
520 - Video Delay DA .....	425.00
521 - Pulse Delay DA .....	375.00
522 - Quad Pulse Delay DA .....	445.00
525 - Subcarrier DA .....	365.00
527 - Dual Subcarrier DA .....	415.00
529 - Color Black Generator .....	505.00
550-1 - Video Processing Amplifier .....	2450.00
550-2 - Dual Video Processing Amplifier .....	4500.00
554 - Remote Gain AGC Amplifier (for 550) .....	505.00
556 - Pulse Output Card (for 550) .....	365.00
557 - White Stretch Module (for 550) .....	470.00
558 - Sync Generator .....	590.00
559 - Color Sync Generator with Gen Lock .....	1240.00
560 - Color Bar Generator .....	750.00
700 - Blank Cover Plate .....	30.00
705 - Power Supply (Audio) .....	180.00
708 - Power Supply (Audio) 220 Volt .....	180.00
706 - Remote Gain Control .....	180.00
707-4 - Audio DA-4 Output .....	320.00
707-6 - Audio DA-6 Output .....	335.00
720 - 5 Watt Monitor Amplifier - Max 2 per power supply .....	265.00

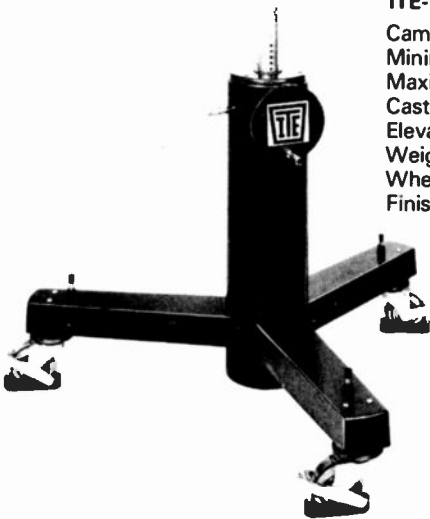

**ITE-P3A Elevation Pedestal**  
 Camera Load Capacity 50 lbs.  
 Minimum Height 31 in.  
 Maximum Height 49 in.  
 Caster Radius 19 in.  
 Elevation Adjustment 18 in.  
 Weight 36 lbs.  
 Wheel Diameter 5 in.  
 Finish Dark Blue  
 (comes equipped with cable guards)  
**\$1150.00**



**ITE-P4 Pedestal**  
 Camera Load Capacity 140 lbs.  
 (first 87 lbs. spring counter-balanced)  
 Minimum Height 34 in.  
 Maximum Height 52 in.  
 Single Wheel Diameter 7 in.  
 (polyurethane)  
 Doorway Width 32 in.  
 Steering Wheel Diameter 25 in.  
 Base Construction Cast Aluminum  
 Weight (less camera balance weights) 180 lbs.  
 Finish Dark Blue  
**\$3995.00**



**ITE-P5 Pedestal**  
 Camera Load Capacity 265 lbs.  
 (First 174 lbs. spring counter-balanced)  
 Minimum Height 34 in.  
 Maximum Height 52 in.  
 Dual Wheel Diameter 7 in.  
 (polyurethane)  
 Doorway Width 32 in.  
 Steering Wheel Diameter 25 in.  
 Base Construction Cast Aluminum  
 Weight (less camera balance weights) 180 lbs.  
 Finish Dark Blue  
**\$4795.00**



**ITE-P6 Pedestal**  
 Camera Load Capacity 120 lbs.  
 Minimum Height 33 in.  
 Maximum Height 52 in.  
 Single Wheel Diameter 7 in.  
 (polyurethane)  
 Doorway Width 28 in.  
 Steering Wheel Diameter 20 in.  
 Base Construction Cast Aluminum  
 Weight 150 lbs.  
 Finish Dark Blue  
**\$3550.00**

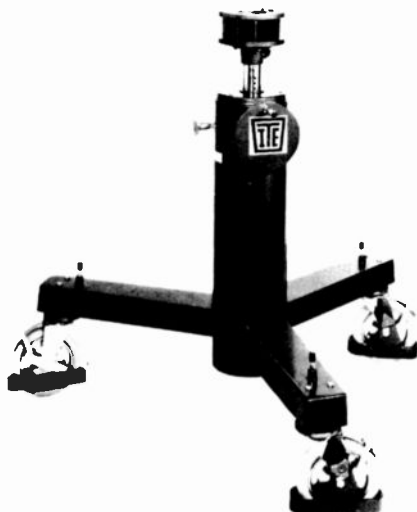

**ITE-P7A Elevation Pedestal**  
 Camera Load Capacity 60 lbs.  
 Minimum Height 32 in.  
 Maximum Height 49 in.  
 Caster Radius 19 in.  
 Elevation Adjustment 18 in.  
 Weight 45 lbs.  
 Wheel Diameter 7 in.  
 Finish Dark Blue  
 Unit has adjustable cable guards  
**\$1295.00**





# INNOVATIVE TELEVISION EQUIPMENT

## DOLLIES

### ITE-D3 Dolly

Camera Load Capacity 110 lbs.  
 Length (folded) 26 in.  
 Height 7 in.  
 Width (folded) 12 in.  
 Diameter 42 in.



Wheel Diameter 5 in.  
 Weight 17 lbs.  
 Finish Aluminum and Dark Blue  
 Accessories Available: ITE-D3G  
 (comes equipped with cable guards)

D3 \$425.00  
 D3G 475.00  
 D3M 465.00

### ITE-D5 Dolly

Camera Load Capacity 60 lbs.  
 Length (folded) 23 in.  
 Height 6 in.  
 Width (folded) 6 in.  
 Weight 7 lbs.  
 Diameter 42 in.  
 Wheel Diameter 5 in.  
 Finish Aluminum and Dark Blue  
 (comes equipped with cable guards)

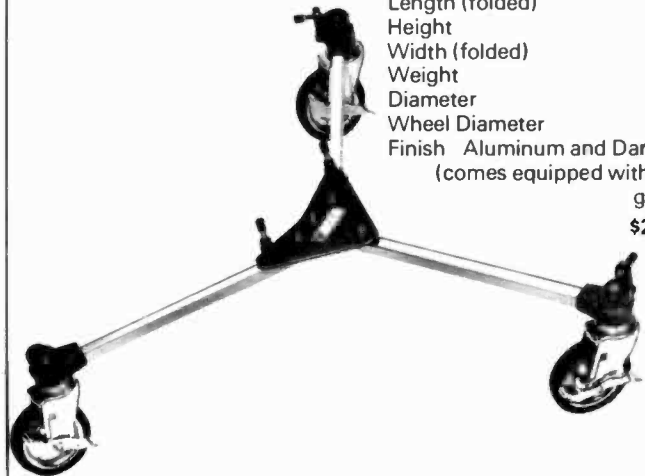

\$280.00

### ITE-D6 Dolly

Camera Load Capacity 60 lbs.  
 Length (folded) 23 in.  
 Height 6 in.  
 Width (folded) 6 in.  
 Weight 7 lbs.  
 Diameter 41 in.  
 Wheel Diameter 5 in.  
 Finish Dark Blue  
 Accessories Available: ITE-D6G  
 (comes equipped with cable guards)

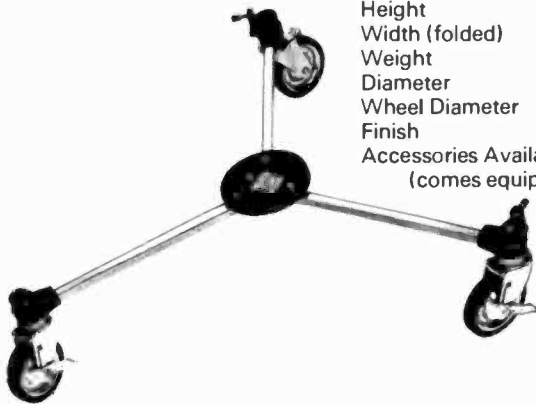

D6 \$185.00  
 D6G 250.00

### ITE-D7 Dolly

Camera Load Capacity 250 lbs.  
 Length (folded) 29 in.  
 Height 9 in.  
 Width (folded) 15 in.



D7 \$725.00  
 D7M 765.00

Weight 25 lbs.  
 Diameter 45 in.  
 Wheel Diameter 7 in.  
 Finish Aluminum and Dark Blue  
 (comes equipped with cable guards)

### ITE-D20 Dolly

Camera Load Capacity 35 lbs.  
 Length (folded) 19 in.  
 Height 9 in.  
 Width (folded) 12 in.  
 Diameter 37 in.  
 Weight 7 lbs.  
 Wheel Diameter 4 in.  
 Finish Aluminum

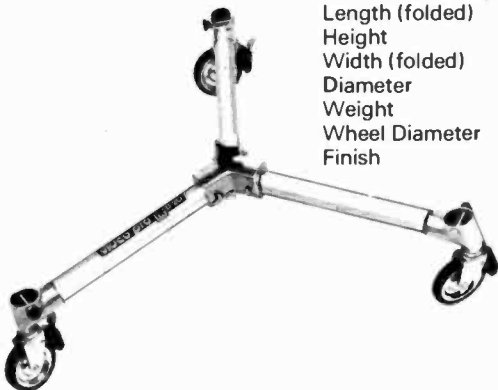

\$95.00

### ITE-TS Tripod Spreader [For ITE/Miller-type Tripods]

This spreader is constructed of sturdy, lightweight aluminum. It will retain tripod legs from a diameter of 32 to 48 inches. Weight is 3 lbs.

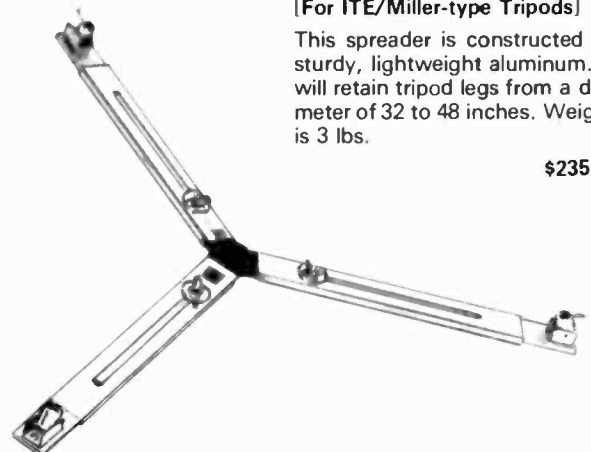

\$235.00



# INNOVATIVE TELEVISION EQUIPMENT

## TRIPODS MICROWAVE HEAD



**ITE-T1B Wood Tripod Ball**  
[Miller-type Senior Model]

Camera Load Capacity	25 lbs.
Folded Length	36 in.
Maximum Height	59 in.
Leg Angle	up to 85°
Folded Width	5 in.
Weight	8 lbs.
Finish	Natural Wood and Dark Blue Metal

**\$395.00**



**ITE-T4 Wood Tripod - Ball**  
[Miller-type Light Pro Mini Model]

Camera Load Capacity	50 lbs.
Folded Length	40 in.
Maximum Height	65 in.
Leg Angle	up to 80°
Folded Width	6 1/2 in.
Weight	12 lbs.
Finish	Natural Wood and Dark Blue Metal

**\$690.00**



**ITE-T5A Elevation Trolley**

Camera Load Capacity	60 lbs.
Minimum Height	38 in.
Maximum Height	58 in.
Minimum Folded Length	40 in.
Maximum Leg Angle	34°
Elevation Adjustment	18 in.
Weight	17 lbs.
Finish	Aluminum and Dark Blue

**\$415.00**



**ITE-T6A Elevation Trolley**

Camera Load Capacity	80 lbs.
Minimum Height	29 in.
Maximum Height	65 in.
Maximum Leg Angle	33 1/2°
Minimum Folded Length	33 in.
Elevation Adjustment	18 in.
Weight	18 lbs.
Finish	Aluminum and Dark Blue

**\$395.00**

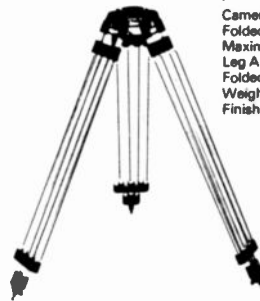

**ITE-T7 Tripod - Ball**  
[Miller-type Medium Duty Model]

Camera Load Capacity	60 lbs.
Folded Length	38 in.
Maximum Height	63 in.
Leg Angle	up to 80°
Folded Width	8 in.
Weight	13 lbs.
Finish	Aluminum and Dark Blue

**\$825.00**

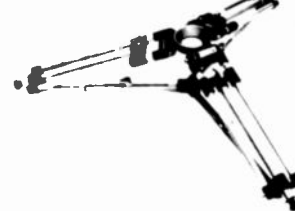

**ITE-T9 Tripod**

Camera Load Capacity	50 lbs.
Folded Length	21 in.
Minimum Height	13-1/2 in.
Maximum Height	29 in.
Maximum Leg Angle	up to 80°
Folded Width	7 in.
Weight	8 lbs.
Finish	Anodized Aluminum and Dark Blue includes removable, adjustable spider (tyrod) assembly.

**\$625.00**



**ITE-T10 Elevation Tripod**

Camera Load Capacity	140 lbs.
Minimum Height	28 in.
Maximum Height	59 in.
Maximum Leg Angle	33 1/2°
Minimum Folded Length	35 in.
Elevation Adjustment	19 in.
Weight	26 lbs.
Finish	Aluminum and Dark Blue

**\$650.00**

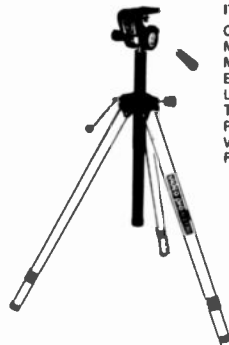

**ITE-T20 Elevation Tripod/Head**

Camera Load Capacity	25 lbs.
Minimum Height	34 in.
Maximum Height	68 in.
Elevation Adjustment	16 in.
Leg Angle	15°
Tilt Angle	+ / - 60°
Pan Rotation	360°
Weight	8 lbs.
Finish	Aluminum and Black Anodized

**\$170.00**

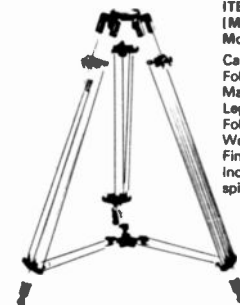

**ITE-T12 Tripod - Ball**  
[Miller-type Light Pro Mini Model]

Camera Load Capacity	50 lbs.
Folded Length	36 in.
Maximum Height	65 in.
Leg Angle	up to 80°
Folded Width	7 in.
Weight	12 lbs.
Finish	Aluminum and Dark Blue includes removable, adjustable spider (tyrod) assembly.

**\$435.00**



**ITE-T13 Tripod**

Camera Load Capacity	70 lbs.
Folded Length	36 in.
Maximum Height	53 in.
Minimum Height (standing)	24 in.
(at maximum leg spread)	
Leg Angle	up to 80°
Folded Width	7 in.
Weight	15 lbs.
Finish	Anodized Aluminum and Dark Blue includes removable, adjustable spider (tyrod) assembly. Footpads optional at extra cost.

**\$795.00**

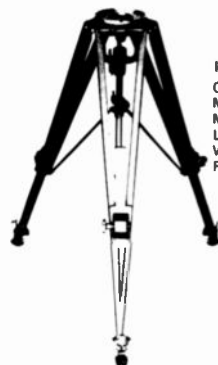

**ITE-MT1 Tripod**

Camera Load Capacity	250 lbs.
Minimum Height	25 in.
Maximum Height	43 in.
Leg Angle	38°
Weight	33 lbs.
Finish	Aluminum and Dark Blue For camera and microwave support.

**\$850.00**

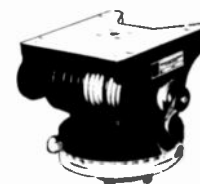

**ITE-H8 Microwave Pan/Tilt Head**

Camera Load Capacity	250 lbs.
Tilt Angle	+ / - 45°
Pan Rotation	45°
Height	7 in.
Width	8 in.
Length	9 in.
Weight	19 lbs.
Finish	Dark Blue
Accessories Available:	Control Handle

**\$750.00**



# INNOVATIVE TELEVISION EQUIPMENT

# HEADS

### ITE-H1 Torsion Head

Camera Load Capacity 30 lbs.  
Tilt Angle + / -45°  
Pan Rotation 360°  
Height 6 in.  
Width 7 in.  
Length 7 in.  
Weight 7 lbs.  
Finish Dark Blue  
Accessories Available: Dual Handles



\$185.00

### ITE-H2 Cam Head

Camera Load Capacity 30 lbs.  
Tilt Angle up to + / -50°  
Pan Rotation 360°  
Height 7 1/2 in.  
Width 9 in.  
Length 10 in.  
Weight 25 lbs.  
Finish Dark Blue  
Accessories Available: Dual Handles and Wedge Adaptor



\$1095.00

### ITE-H3 Cam Head

Camera Load Capacity 250 lbs.  
Tilt Angle up to + / -60°  
Pan Rotation 360°  
Height (including Wedge Adaptor) 8 1/2 in.  
Width 12 1/2 in.  
Length 12 1/2 in.  
Weight 32 lbs.  
Finish Dark Blue  
Accessories Available: Dual Handles



\$2225.00

### ITE-H4 Torsion Head

Camera Load Capacity 40 lbs.  
Tilt Angle + / -45°  
Pan Rotation 360°  
Height 6 in.  
Width 8 in.  
Length 8 in.

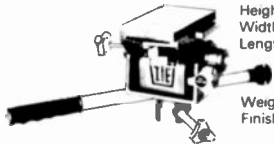

Weight 8 lbs.  
Finish Dark Blue

\$225.00

### ITE-H4D Torsion Head

Camera Load Capacity 40 lbs.  
Tilt Angle + / -45°  
Pan Rotation 360°  
Height 6 in.



Width 8 in.  
Length 8 in.  
Weight 8 lbs.  
Finish Dark Blue  
(includes dual handles)

\$295.00

### ITE-H5 Hydro Head

Camera Load Capacity 50 lbs.  
Tilt Angle + / -48°  
Pan Rotation 360°  
Height 7 1/2 in.  
Width 8 1/2 in.  
Length 9 in.  
Weight 15 lbs.  
Finish Dark Blue  
Camera Mounting Plate/Quick Release: 6"(l) x 2"(w) with 3/8" slot for mounting cameras with 1/4" or 3/8" screws



Accessories Available: Dual Handles and Wedge Adaptor

\$1895.00

### ITE-H6 Hydrocam Head

Camera Load Capacity 120 lbs.  
Tilt Angle up to + / -50°  
Pan Rotation 360°  
Height 9 in.  
Width 9 in.  
Length 9 1/2 in.  
Weight 23 lbs.  
Finish Dark Blue  
Includes dual handles and wedge adaptor

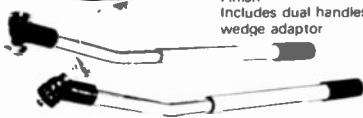

2395.00

### ITE-H7 Torsion Head

Camera Load Capacity 60 lbs.  
Tilt Angle + / -45°  
Pan Rotation 360°  
Height 8 1/2 in.  
Width 7 1/2 in.



Length 8 1/2 in.  
Weight 13 lbs.  
Finish Dark Blue  
(includes dual handles)

\$850.00

### ITE-H9 Hydro Head

Camera Load Capacity 30 lbs.  
Tilt Angle + / -45°  
Pan Rotation 360°  
Height 6 1/2 in.  
Width 7 in.  
Length 8 in.  
Weight 8 lbs.  
Finish Dark Blue  
Camera Mounting Plate/Quick Release: 5"(l) x 2"(w) with 3/8" slot for mounting cameras with 1/4" or 3/8" screws



Accessories Available: Dual Handles

\$1145.00

### ITE-H10 Hydro Head

Camera Load Capacity 40 lbs.  
Tilt Angle up 80°, down 80°  
Pan Rotation 360°  
Height 7-1/4 in.  
Width 6-3/4 in.



Length 6-3/4 in.  
Weight 9 lbs.  
Finish Dark Blue  
Camera Mounting Plate/Quick Release: 4"(l) x 2"(w) with 3/8" slot for mounting cameras with 1/4" or 3/8" screws  
Accessories Available: Dual Handles

\$1475.00

### ITE-H11 Fluid Head (Miller-type Super "8" Model)

Camera Load Capacity 10 lbs.  
Tilt Angle + / -80°  
Pan Rotation 360°  
Height 5 in.



Width 3 1/2 in.  
Length 4 in.  
Weight 2 lbs.  
Finish Dark Blue  
Accessories Available: Ball Leveling

\$335.00

### ITE-H12 Fluid Head (Miller-type Senior "F" Model)

Camera Load Capacity 20 lbs.  
Tilt Angle + / -80°  
Pan Rotation 360°  
Height 5 in.



Width 4 in.  
Length 4 1/2 in.  
Weight 5 lbs.  
Finish Dark Blue  
Accessories Available: Ball Leveling

\$895.00

### ITE-H13 Fluid Head (Miller-type Light Pro Model)

Camera Load Capacity 30 lbs.  
Tilt Angle + / -80°  
Pan Rotation 360°  
Height 5 1/2 in.  
Width 6 1/2 in.  
Length 5 1/2 in.  
Weight 8 lbs.



Finish Dark Blue  
Accessories Available: Dual Handles and Ball Leveling

\$925.00

### ITE-H14 Fluid Head (Miller-type Light Pro Model with Positive Heavy Duty Tilt Lock)

Camera Load Capacity 30 lbs.  
Tilt Angle + / -80°  
Pan Rotation 360°  
Height 5 1/2 in.  
Width 6 1/2 in.  
Length 5 1/2 in.  
Weight 8 lbs.  
Finish Dark Blue



Accessories Available: Ball Leveling  
(-H14 has positive heavy duty tilt lock)

\$995.00

### ITE-H15 Fluid Head (Miller-type V.G. 50 Model)

Camera Load Capacity 40 lbs.  
Tilt Angle + / -75°  
Pan Rotation 360°  
Height 6 1/2 in.  
Width 6 in.  
Length 7 in.  
Weight 8 lbs.  
Finish Dark Blue



Accessories Available: Dual Handles and Ball Leveling

\$1150.00



# INNOVATIVE TELEVISION EQUIPMENT ACCESSORIES

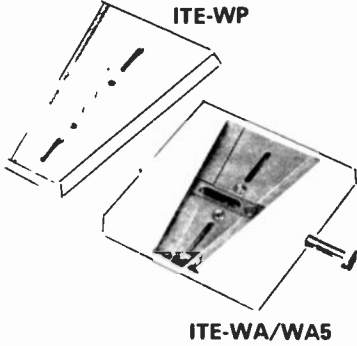

**Wedge Adaptor Assemblies**  
The ITE Wedge Plate and Adaptor combination provide for rapid attachment and removal of camera from pan/tilt head. Positive attachment of wedge plate to adaptor is accomplished by rotation of a locking screw which makes inadvertent disengagement impossible.

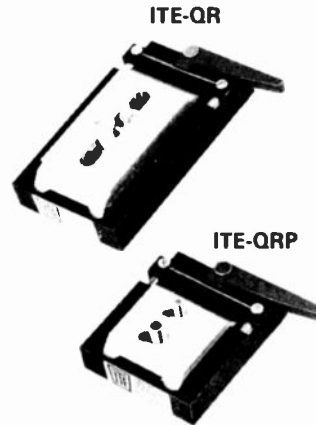

**Quick Release Assemblies**  
The ITE Quick Release Assembly provides for rapid attachment and removal of camera from pan/tilt head. Positive attachment of plate to adaptor is accomplished by rotating a spring-loaded lever. Inadvertent disengagement is impossible.  
Use in conjunction with Models ITE-H1, -H4, -H5, -H7, -H11, -H12, -H13, -H14, and -H15.



**ITE-HH6 Hi-Hat**  
Camera Load Capacity 300 lbs.  
Height 6 in.  
Maximum Width 7 1/2 in.  
Mounting Bolt Circle 6 1/2 in.  
Bolt Attachment Size 3/8 in.  
Finish Dark Blue

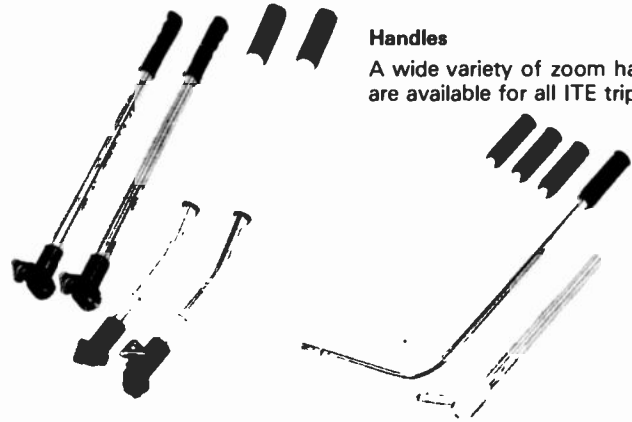

**Handles**  
A wide variety of zoom handles are available for all ITE tripods.



**ITE-H9TCB Claw Ball Adaptor**  
Interfaces ITE-H9 Head to T4, T7, T8 and T12 Tripods.  
**ITE-H2T Claw Ball Assembly**  
For H2 and H5 to T6, T10, T13 and P7 Tripods.

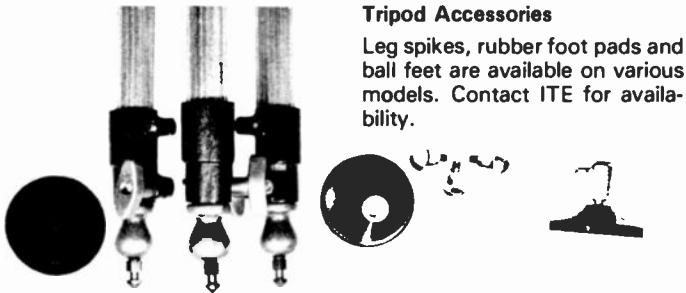

**Tripod Accessories**  
Leg spikes, rubber foot pads and ball feet are available on various models. Contact ITE for availability.



ITE-H79P



ITE-MHT

**ITE-Adaptors**  
For interface of all ITE products.

ITE-WA Wedge Adaptor — H2	\$180.00
ITE-WA5 Wedge Adaptor — H5	225.00
ITE-WP Wedge Plate	125.00
ITE-RH Right Hand Zoom Handle for H2	75.00
ITE-RH3 Right Hand Zoom Handle for H3	125.00
ITE-RH5/9 Right Hand Zoom Handle for H5 and H9	100.00
ITE-RH9P Right Hand Zoom Handle For H9P — Philips	115.00
ITE-RHM Right Hand Zoom Handle for H13, H14, H15, and H16	65.00
ITE-H79P Adaptor — for H9 and H10 to P4 and P6 Pedestals	150.00
ITE-H25T Adaptor — for H2 and H5 to T6, T10, T13 and P7	95.00
ITE-H9TCB Adaptor — H9 to T4, T7, T8 and T12	140.00
ITE-CB3 Claw Ball Assembly — for T4, T7, T8 and T12	80.00
ITE-HH6 Hi Hat — 6"	135.00
ITE-CW Counterweight Set (40 lbs.) for P4/5	185.00
ITE-TK Adaptor — RCA TK-44, 45 and 46	225.00
ITE-RFPM Rubber Foot Pad Set — M Tripods	85.00
ITE-RFPI Rubber Foot Pad Set — for T2A, T6, T12 and T13	95.00
ITE-CB1 Claw Ball Assembly — for T1B Tripod	70.00
ITE-QR Quick Release Adaptor Assembly	155.00
ITE-QRP Quick Release Adaptor — Plate	35.00
ITE-EXT Extender Plate — for Balance of Studio/ENG Camera	45.00
ITE-H2TH Telescopic Handle for H2 and H6	135.00
ITE-H3TH Telescopic Handle for H3	165.00
ITE-H25CB3 Adaptor — H5 to T4, T7 and T12 Tripods	235.00
ITE-RH4K Kit — Right Hand Handle Conversion for H4	95.00
ITE-SPS Spike Set (3 each) — for T2A, T6, T10, T12, and T13	40.00
ITE-CTH Shipping Case — for T1B, T4, T6, T7, T10, T12 and T13 Tripod with H9, H10, H11, H12, H13, H14, H15 and H16 Head	324.00
ITE-CD2 Shipping Case — for D5, D6 and D7 Dolly	247.50
ITE-CH2 Shipping Case — for H2, H5, H6, H9 and H10 Pan/Tilt head with Handles and Accessories	291.50

Prices and Specifications Subject to Change Without Notice.

# JVC

US JVC Corp.

PROFESSIONAL VIDEO DIVISION

## PROFESSIONAL THREE TUBE COLOR CAMERA



KY-1900U

KY-1900

### STANDARD PORTABLE ACCESSORIES

- Color camera head
- 1 1/2" Viewfinder
- AC Adaptor/Battery charger with cable
- Rechargeable battery
- Battery bracket for B-20 battery
- 6:1 Manual zoom lens, handgrip
- or
- 10:1 Servo zoom lens
- Standard Carrying Case
- Microphone Holder
- Shoulder Pad
- Instruction Manual

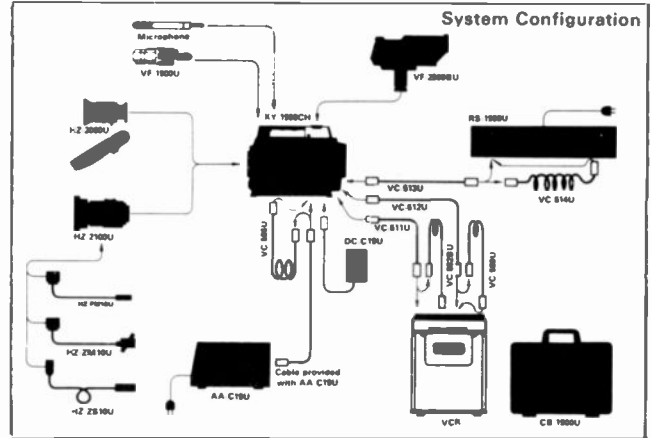

### KY-1900U Portable Three-Tube Professional Color Video Camera

- Super-compact professional quality color video camera
- 4-1/4"W x 7-13/32"H x 11-23/32"D. Weight 7.7 lbs.
- Power consumption only 15W (with viewfinder)
- Three 2/3" (17.7mm) Saticon tubes newly designed for quick warm-up convenience
- High-performance parallel optical system with multi-layer coated lenses and dichroic mirrors
- Rugged construction with diecast aluminum frame
- High signal-to-noise ratio of 52dB plus 9dB GAIN available for really low light situations
- 6:1 zoom lens with auto iris, 10:1 servo zoom lens, or 14:1 servo zoom lens can be used
- Automatic iris control with weighting detection circuit to reduce the sensitivity for the upper part of the frame
- ABC (Automatic Beam Control), knee compression and white clip circuits for highlight processing
- Y, I and Q encoder provided
- R, G and B output signals through the optional RS-1900U
- Automatic white balance control circuit with 8-bit digital memory
- C-mount and special lens mount enable using a 200-2000mm lens for 35-mm still cameras by employing an adaptor ring
- Plug-in circuit board construction for easy serviceability
- Built-in genlock circuit and color bar generator
- Higher portability with provided battery and AC adaptor (also used as a quick charger)
- Studio setup also is made possible with optional VF-2500BU 5" viewfinder, RS-1900U Remote Control Unit, and specified cables

KY-1900CHL6 .....	\$4900.00
KY-1900U with f/1.6 6 to 1 lens	
KY-1900CHL10 .....	\$5700.00
KY-1900U with f/1.6 10 to 1 lens	
KY-1900CH .....	\$2700.00
Camera Head only with carrying case	

### Accessories for KY-1900 Color Camera

MODEL	DESCRIPTION	ESTIMATED SHIPPING WT. (LBS.)	PRICE
AAC-19U	AC Adaptor/Battery Charger (For DC-C19U Only)	4.0	\$ 300.00
* B-20	Rechargeable Ni-Cad Battery (4 AH)	5.4	435.00
* C-20	Charger for B-20 Battery	1.0	71.00
CB-1900KY	Molded Shipping Case	16.0	260.00
DC-C19U	Rechargeable Battery (2 AH)	4.0	150.00
* F-20	Fast Charger for B-20 Battery	5.0	420.00
* FA-3000U	Film Chain Adaptor	7.6	2300.00
* FL-08U	Lens for 8mm Projector to FA-3000U	0.7	250.00
* FL-16U	Lens for 16mm Projector to FA-3000U	0.7	250.00
* FL-35U	Lens for 35mm Projector to FA-3000U	0.7	250.00
* HZ-EX2	2X Lens Converter for HZ-2100U or HZ-2140U	1.5	200.00
* HZ-FM10U	Rear Manual Focus Control for HZ-2100U	3.0	285.00
* HZ-FM14U	Rear Manual Focus Control for HZ-2140U	3.7	410.00
* HZ-FB14U	Rear Servo Focus Control for HZ-2140U	4.0	1250.00
* HZ-LCA	Nikon Lens to KY Camera Adaptor	1.0	300.00
* HZ-ZM10U	Rear Manual Zoom Control for HZ-2100U	3.0	285.00
* HZ-ZM14U	Rear Manual Zoom Control for HZ-2140U	3.7	460.00
* HZ-ZS10U	Rear Servo Zoom Control for HZ-2100U	2.0	430.00
* HZ-ZS14U	Rear Manual Zoom Control for HZ-2140U	2.0	460.00
HZ-2060U	f 1.6, 6:1, 11-70mm Manual Zoom Lens, with Hand Grip	4.0	430.00
* HZ-2100U	f 1.6, 10:1, 10-100mm Servo Zoom Lens	5.0	1160.00
* HZ-2140U	f 1.7, 14:1, 10-140mm Servo Zoom Lens	6.0	1900.00
* M-510X	Electret Condenser Microphone	2.0	199.00
MA-1000U	Microscope Adaptor	2.4	1150.00
MH-1000U	Microscope Base for MA-1000U	21.7	610.00
G-19	Battery Bracket for B-20 Battery	1.0	43.00
RS-1900U	Remote Control Unit	12.0	585.00
VC-511U	Camera to VCR Cable (10 pin) 4m/13ft	2.0	145.00
VC-512U	Camera to VCR Cable (14 pin) 4m/13ft	4.0	145.00
VC-513U	Camera to RS-1900U Cable 20m/65ft	5.0	335.00
VC-514U	Extension Cable for VC-513U 20m/65ft	5.0	385.00
* VC-582BU	Camera Extension Cable (10 pin-10 pin) 10m/33ft	5.5	199.00
* VC-589U	Camera Extension Cable (14 pin-14 pin) 10m/33ft	5.5	215.00
* VC-588U	Extension Cable for AA-C19U (4 pin) 5m/16 ft	2.7	141.50
VF-1900U	1 1/2" Electronic Viewfinder	4.5	360.00
* VF-2500BU	5" Electronic Viewfinder	7.8	613.00
* 24KJFZU	HZ-C30 to HZ-2100U Lens Adaptor	1.5	130.00

\* Model compatible with KY-2700 Series Camera

# JVC

US JVC Corp.

PROFESSIONAL VIDEO DIVISION

## PROFESSIONAL COLOR CAMERA SYSTEM

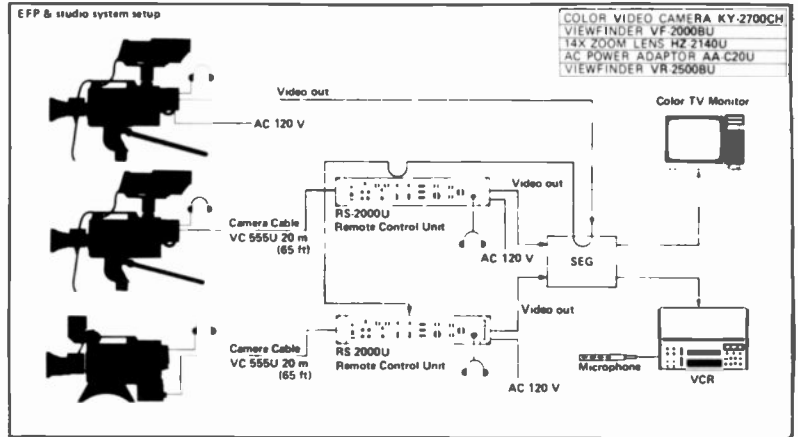

### KY-2700 A

- Three 2/3" (17.7mm) Saticon\* tubes newly designed for quick warmup convenience
- High-performance parallel optical system with multi-layer coated lenses and dichroic mirrors
- Rugged construction with diecast aluminum body
- Compact and lightweight with well-balanced weight distribution when held on the shoulder and low power consumption — ideal for ENG/EFP applications
- C-mount and special lens mount, accommodating a wide variety of lenses
- Plug-in genlock circuit, color bar generator and adjustable H/V blanking width circuit
- RGB signal outputs directly available from the RS-2000U
- Full remote control and power from a distance of up to 30m (980 ft) in combination with the RS-2000U
- High-performance 14X or 10X servo zoom lens available
- FET-equipped video preamplifiers used to give a high signal-to-noise ratio of 54 dB
- 2H delay line for vertical image enhancement
- ABC (Automatic Beam Compensation), knee compression and white clip circuits for highlight processing
- Precision-made deflection yokes for higher registration accuracy
- Automatic white balance circuit with 8-bit digital memory
- Automatic iris control with weighting detection circuit to reduce the sensitivity for the upper part of the picture
- ABS (Automatic Black Stabilizer) circuit incorporated
- Updated Features:
  - 600 line resolution
  - Master Black control

### Standard Accessories

- Carrying case
- Shoulder pad
- Power adaptor holder
- Registration chart
- Mic holder
- 3.15 AMP fuse
- BNC L-type adaptor
- PCB extension board
- Dust/moisture cover
- Auto white memory battery
- Service manual

### CAMERA SYSTEMS

KY-2700APSX14 Portable Color Camera System **\$9800.00**

KY-2700APSX14 Components:

KY-2700ACH Camera Head  
 AA-C20U AC Adaptor  
 VF-2000BU 1.5 inch Viewfinder  
 HZ-2140U 14:1 Servo Zoom Lens  
 B-20/C-20/Q-27 12 Volt Battery, slow charger, and mount

KY-2700ASSX14 Studio Color Camera System **\$9260.00**

KY-2700ASSX14 Components:

KY-2700ACH Camera Head  
 AA-C20U AC Adaptor  
 VF-2500BU 5 inch Viewfinder  
 HZ-2140U 14:1 Servo Zoom Lens

KY-2700APSX10 (10-1 LENS) **\$9080.00**

KY-2700ASSX10 (10-1 LENS) **8540.00**

KY-2700AT Color Camera Head Only with AC Adaptor **6860.00**

KY-2700ACH Camera Head Alone **6430.00**

### PS (Portable System)

KY-2700CH Color camera head  
 AA-C20U AC adaptor  
 VF-2000BU 1 1/2" Electronic viewfinder  
 B-20 4 AH rechargeable battery  
 C-20 Charger for B-20 battery  
 Q-27 Battery Bracket for B-20 battery

### SS (Studio System)

KY-2700ACH Camera Head  
 AA-C20U AC adaptor  
 VF-2500U 5" Electronic viewfinder  
 HZ-2140U 14:1 Servo zoom lens or  
 HZ-2100U 10:1 Servo zoom lens  
 Standard Accessories

### T (Telecine System)

KY-2700ACH Camera Head  
 AA-C20U AC Adaptor

### PS & SS SYSTEMS STANDARD ACCESSORIES

- Molded carrying/shipping case with casters
- Fitted shoulder pad
- AC adaptor bracket
- Service/Instruction Manual
- Registration chart
- Microphone holder
- 3.15 Amp power fuse
- BNC L-Type adaptor
- Printed circuit board extender
- Dust/moisture cover
- Auto white memory battery

### Accessories for KY-2700 Color Camera

MODEL	DESCR PTION	WT. (LBS.)	PRICE
AA-C20	AC Adaptor	5.4	\$ 430.00
B-20	Rechargeable Ni-Cad Battery (4AH)	5.4	435.00
C-20	Charger for B-20 Battery	1.0	71.00
CB-2000S	Soft Carrying Case for KY-Series Cameras	3.0	160.00
F-20	Fast Charger for B-20 Battery	5.0	420.00
FA-3000U	Film Chain Adaptor	7.6	2300.00
FL-08U	Lens for 8mm Projector to FA-3000U	0.7	250.00
FL-18U	Lens for 18mm Projector to FA-3000U	0.7	250.00
FL-35U	Lens for 35mm Projector to FA-3000U	0.7	250.00
HZ-EX2	2X Lens Converter for HZ-2100U or HZ-2140U	1.5	200.00
HZ-FM10U	Rear Manual Focus Control for HZ-2100U	3.0	285.00
HZ-FM14U	Rear Manual Focus Control for HZ-2140U	3.7	410.00
HZ-FB14U	Rear Servo Focus Control for HZ-2140U	4.0	1250.00
HZ-LCA	Nikon Lens to KY-Series Camera Adaptor	1.0	300.00
HZ-ZM10U	Rear Manual Zoom Control for HZ-2100U	3.0	285.00
HZ-ZM14U	Rear Manual Zoom Control for HZ-2140U	3.7	480.00
HZ-ZB10U	Rear Servo Zoom Control for HZ-2100U	2.0	430.00
HZ-ZB14U	Rear Servo Zoom Control for HZ-2140U	2.0	460.00
HZ-2100U	f 1.6, 10:1, 10-100mm Servo Zoom Lens	5.0	1180.00
HZ-2140U	f 1.7, 14:1, 10-140mm Servo Zoom Lens	6.0	1900.00
JB50	Junction Connector for VC-556 Cables	2.0	80.00
M-510X	Electret Condenser Microphone	2.0	199.00
MA-1000U	Microscope Adaptor	2.4	1150.00
MH-1000U	Microscope Base for MA-1000U	21.7	610.00
Q-27	Battery Bracket for B-20 Battery	1.0	120.00
RS-2000U	Remote Control Unit	17.0	1205.00
VC-555U	Camera to RS-2000U Cable 20m/65 ft.	14.0	568.00
VC-556-00	Camera to RS-2000U Cable (Heavy Gauge) 20m/65ft.	20.0	800.00
VC-556-05	Camera to RS-2000U Cable 50m/165 ft.	30.0	1185.00
VC-556-10	Camera to RS-2000U Cable 100m/330ft. (Longer Length Cables available on special order)	45.0	2080.00
VC-582BU	Camera Extension Cable (10pin-10pin) 10m/33ft.	5.5	199.00
VC-584U	Camera to VCR Cable (10pin) 4m/13ft.	2.0	185.00
VC-588U	Extension Cable for AA-C20 (4pin) 5m/16ft.	2.7	141.50
VC-588U	Camera to VCR Cable (14pin) 4m/13ft.	2.0	185.00
VC-589U	Camera Extension Cable (14pin-14pin) 10m/33ft.	5.5	215.00
VF-2000BU	1 1/2" Electronic Viewfinder	5.5	440.00
VF-2500BU	5" Electronic Viewfinder	7.8	613.00
24KFZU	HZ-C30 to HZ-2100U Lens Adaptor	1.5	130.00

\* Model compatible with KY-1900 Color Camera

Prices and Specifications Subject to Change Without Notice.

# JVC

US JVC Corp.

PROFESSIONAL VIDEO DIVISION

## 1" COLOR CAMERAS AND ACCESSORIES

**NEW! S62U**

Introduced 4/82 at NAB  
(Photo Not Available at Presstime)



S-100PS

### S62U Color Video Camera

**\$1395.00**

• Color video camera • 1-1" SATICON® tube, 6 to 1 auto iris C mount zoom lens with macro feature, 1 1/2" electronic viewfinder with LED iris, battery warning and VCR start/stop indicators, return video capability in viewfinder, built-in microphone, VCR start/stop trigger, sensitivity switch, AC adaptor, outdoor filter, 20' cables for HR-6700, HR-2200U, HR-7300, HR-7650, HR-2650, BR-6200

### S-100PS One Tube Portable Saticon Color Video Camera

Light weight and economy have been achieved through the use of a single 1" Saticon\* tube together with a color stripe filter; the Saticon tube gives superb color reproduction and picture resolution with lower lag.

Another industry-first from JVC — the S-100PS video camera has a built-in "Sound Zoom" microphone. The directivity of the microphone is automatically varied from super-directional to omni-directional and vice versa, being linked with the semi-servo controlled 10:1 power zoom lens. Manual selection of the directivity is also possible.

For better operability, the 1.5" B and W electronic viewfinder displays exposure indication and other information necessary for optimum use of the camera; for convenience the position of the viewfinder is freely adjustable. So that any other camera lens can be substituted for the standard 10X power zoom lens, the S-100PS is provided with special and "C" lens mounts. Includes a carrying case.

The S-100PS is a portable color video camera, combining the quality that professionals expect with flexibility that makes it ideal for a wide range of applications in business, education and industry.

**S-100PS ENSEMBLE** — Color Video Camera 1-1" Saticon tube, 10:1 auto iris servo Zoom lens with macro focus, 1.5" electronic viewfinder. Zoom microphone with windscreen, handgrip/shoulder pad, AC adaptor, VTR cable, shipping case **\$2300.00**

**S-100CH CAMERA HEAD ONLY** — Includes Ac adaptor plus VC404 extension and VC408 Breakout cables. For film-to-tape transfers and microscope use. **\$1750.00**

### Optional Accessories for Color Cameras

Model	Description	Price
B-10A	Battery for BKT-100A	\$225.00
B-502	Battery for BKT-112	77.50
BH-112	Battery charger for BKT-112	16.00
BKT-100A	Battery Kit for S-100/G-71	350.00
BKT-112	Battery Kit for G-71 camera	107.00
C-10A	Battery Charger for B-10A	70.00
CB-100S	Soft case for S-100	125.00
CVF-503	1 1/2" electronic viewfinder for G-71	188.00
CVL-617AMS	6:1 auto iris macro zoom lens for G-71	429.00
DC-10S	Cable for B-10A to S-100/G-71	65.00
GN-C80U	Camera Adaptor Unit for S-100/G-71	340.00
Q-10A	Battery holder with belt loop	35.00
TAC-300	Tele-cine converter	110.00
VC-404	Camera extension cable 3m (9')	42.50
VC-405	Camera extension cable 10m (33')	63.00
VC-418-10S	Extension Cable for GN-C80 10m (33')	185.00
VC-422-3SY	Camera Cable S-100 to type VCR	145.00
CV-CF10	Lens Filter for G71US camera	30.00
VC-408-3D	Breakout Cable for G71US camera	75.00

\*Saticon is a registered trademark.

# JVC

US JVC Corp.

PROFESSIONAL VIDEO DIVISION

## 1/2" VHS VCR DECKS



HR-7650 VIDEOCASSETTE RECORDER

### NEW!

#### HR7650 and HR2650U VCR's with Stereo

Sophistication, Styling, Feature-packed, Ease of operation.

Now all the design concepts are brought together in this video masterpiece. All the video claims and expectations realized. Introducing JVC's new, top-of-the-line Vidstar HR-7650U—a first-rate video recorder that's in a class of its own.

Here's The Premier VHS Machine On The Market Today!

Highlights are full-function infrared remote control, stereophonic sound reproduction with Dolby® NR, and a 105-channel cable-ready capacity.

#### HR-7650 Features

**\$1595.00**

All features of HR-7300, plus the following:

- Wireless 15 function Remote Control • Dual Audio Tracks, Stereo Dolby System • 105 Channel Cable Ready • Front panel slot loading • Backspace assemble editing • Manual distortion on insert edits • Freeze Frame, from advance • 5 motors, direct head drive • 10 minute power outage back up for clock

#### HR-7650 SPECIFICATIONS

- Format: VHS standard, 1/2 inch • Recording system: Rotary, slant azimuth two-head helical scan system with two pairs of video heads, one pair exclusively for the SP mode and one pair for the EP mode • Video signal system: NTSC • Tape speed: SP:33.35mm/s (1-5/16 ips); LP:16.67mm/s (21/32 ips); EP:11.12mm/s (7/16 ips) • Maximum recording time: SP:120 min. with T-120; EP:360 min. with T-120 • Temperature Operating: 5°C to 40°C (41-104°F) • Antenna: VHF:75 ohms, unbalanced, UHF:300 ohms, balanced • Channel coverage: VHF:Channels VL 2-6, VH A-I, 7-13, J-W, UHF: Channels 14-83 • VHF output signal: Channel 3 or 4 • Power requirement: 120 V AC, 60 Hz • Power consumption: 47 W (62 W w/camera) • Video: Input: 0.5 to 2.0 Vp-p, 75 ohms, unbalanced; Output: 1.0 Vp-p, 75 ohms, unbalanced; Signal-to-noise ratio: More than 45 dB • Horizontal resolution: 240 min. • Audio: Input: Mic: -67 dBs 10 k-ohms, unbalanced; Line: -20 dBs 50 k-ohms, unbalanced Output level: -6 dBs, high Z load; Output impedance: Less than 1 K, unbalanced; Signal-to-noise ratio: More than 46 dB (Dolby NR on); Frequency range: 70 Hz to 10 kHz • Timer: 14-day programmable timer/8 events • Dimensions: 460mm W x 154mm H x 371mm (18-1/8" x 6-1/8" x 14-5/8") • Weight: 12 kg (26.5 lbs.) • Provided accessories: Channel number film, Antenna cable (F-type), Cassette tape, Matching transformer, Infrared remote control

#### HR2650U Component Video Recorder

**\$1150.00**

#### TU26U Tuner/Timer/Adaptor/Charger

**\$375.00**

For HR2650U • 14 days/8 events settings

#### CBP26 Carry Bag for HR2650U

**\$75.00**

#### VCP714 Adaptor to use AAP22/TU22/APP22 with HR2650U

**\$32.00**



HR-7300U VIDEOCASSETTE RECORDER

#### HR-7300U

**\$1050.00**

- Four-head system for picture clarity • Shuttle-search • Full-logic electronic operation • 8-Event/14-Day timer • Direct-drive head drum motor • Full-function remote control

To achieve 6-hour recording and playback capability while retaining excellent picture quality, JVC designed the 4-head system, with independent pairs of heads for the 2-hour (Standard Play) and 6-hour (Extended Play) modes. This innovative system means that the same superb picture quality, the hallmark of JVC and VHS, is maintained in the EP mode.

As well as recording in the 2-hour and 6-hour modes, the HR-7300U is equipped to playback 4-hour (Long Play) cassettes. To playback you don't have to worry about the mode used for recording; just insert the cassette and SP/LP/EP switching is done automatically.

**Auto rewind at tape end** so that your tapes are always rewound and ready to pop in to start playback from the beginning.

**14-channel pretunable electronic tuner:** preset the channels, then channel selection is done by simply pressing a button.

**Counter search** operates in the rewind mode to stop the tape just before the point at which the counter was reset to "0000".

**Air-damped cassette holder** lifts gently when you press the eject button

**Audio dubbing** is possible; this means you can add sound to a recording without disturbing the picture.

**Automatic channel lock** means that you can't change channels accidentally once you've started recording.

**Full-function remote control** for channel selection, shuttle search in both directions, record, play, audio dubbing, pause, rewind, fast forward and stop.



# JVC

US JVC Corp.

PROFESSIONAL VIDEO DIVISION

## 3/4" COLOR VIDEOCASSETTE PLAYERS/RECORDERS

### CP-5000U

#### 3/4" Color Videocassette Player

- Crisp, clear pictures with APC (Automatic Phase Control) and ACC (Automatic Color Control) circuits • Solenoid-operated. May be remote-controlled with optional RM-51U Remote Control Unit • May be connected to a color TV receiver for playback, using an optional RF converter (KR-500 Series) • Full repeat and counter repeat, both automatic • Stereophonic or bilingual audio • Drop-out compensator

• Dimensions (WHD): 526 x 195 x 450 mm (20-3/4" x 7-11/16" x 17-3/4") • Weight: 26 kg (58 lbs.)

CP-5000U Color videocassette player, automatic repeat **\$1330.00**

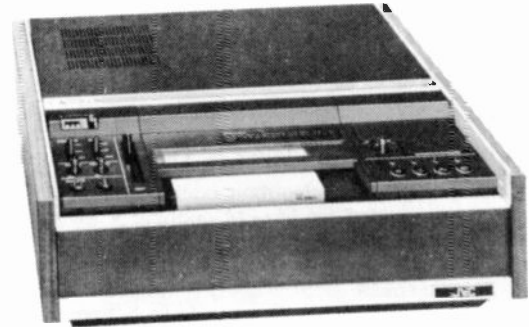

CP-5000U

### CP-5200U

#### 3/4" Color Videocassette Player with Stillframe

- APC and ACC circuits • Still-frame picture playback capability • Solenoid-operated. May be remote-controlled (with optional RM-51U) • Connectable to a color TV receiver for playback with an optional RF converter (KR-234U or KR-256U) • Full repeat and counter repeat, both automatic • Stereophonic or bilingual audio • Dropout compensator

• Dimensions (WHD): 526 x 195 x 450 mm (20-3/4" x 7-11/16" x 17-3/4") • Weight: 26 kg (58 lbs.)

CP-5200U Color videocassette player with still frame, automatic repeat **\$1490.00**

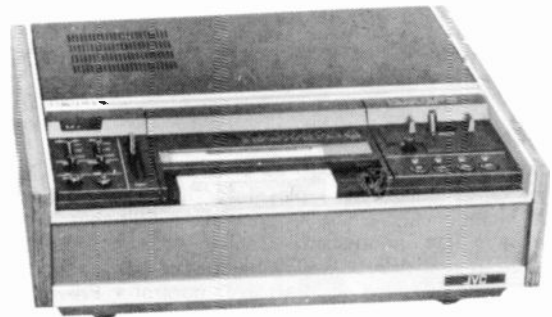

CP-5200U

### CR-6060U

#### 3/4" Color Videocassette Recorder

- May be fully remote-controlled with the use of the optional RM-60U Remote Control Unit • Audio level controls with level meters • Audio limiter circuit built in • Pause and still-frame capability • Automatic search and repeat • Stereophonic or bilingual audio • Timer start capability • Frame advance

• Dimensions (WHD): 526 x 195 x 450 mm (20-3/4" x 7-11/16" x 17-3/4") • Weight: 26 kg (58 lbs.)

CR-6060U Color videocassette recorder/player with still frame, manual audio, with level meters, fully remote controllable with optional RM-60 remote control unit, automatic repeat

**\$1990.00**



CR-6060U



US JVC Corp.  
PROFESSIONAL VIDEO DIVISION

## PROFESSIONAL TAPE HANDLERS 3/4" EDITING SYSTEMS

### 3/4" COLOR VIDEO CASSETTE PLAYER

#### CP-5500U

#### 3/4" Color Videocassette Player — Direct Drive

- Ideal for use as a player in electronic editing system • FM signal output connector provided for FM-FM dubbing • Microcomputer-assisted logic control with direct mode change • High reliability, stability and durability due to advanced mechanisms and servo systems • Variable-speed shuttle-search function via optional RM-70U, RM-82U or RM-88U • Capstan servo system for external-lock playback • Time base corrector connectable • Electronic tape counter/timekeeper • Optional RF output

- Dimensions (WHD): 564 x 221 x 471 mm (22-1/4" x 8-3/4" x 18-9/16") • Weight: 29.4 kg (65 lbs.)

CP-5500U 3/4" Color Videocassette Player **\$2730.00**



CP-5500U

### EDITING CONTROL UNITS

#### RM-88U

#### Automatic Editing Control Unit

- Combined with the CR-8200U as a recorder and the CP-5500U, CR-6600U or CR-8200U as a player for high-precision automatic editing • Memory of edit-in/edit-out points • Edit-shift for edit point correction • 7-digit fluorescent display time counter allowing edit-in/edit-out indication as well as readout of elapsed time and edit lap time • Variable-speed shuttle-search control • Preview editing

- Dimensions (WHD): 440 x 86 x 238 mm (17-3/8" x 3-7/16" x 9-3/8") • Weight: 5.5 kg (12.2 lbs.)

RM-88U Full Function, Automatic Editing Control Unit **\$3200.00**

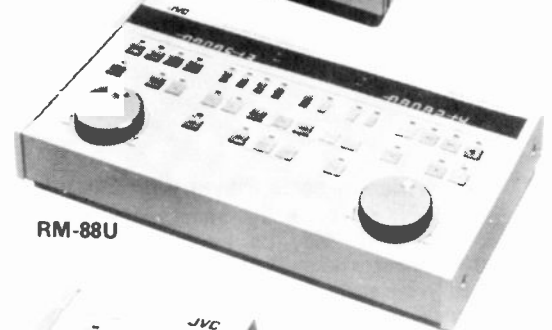

RM-88U

### REMOTE CONTROL UNIT

#### RM-70U

#### Remote Control Unit

- Remote control of all operations of the CR-8200U, CR-6600U or CP-5500U • Variable-speed shuttle-search function (at speeds from zero to 5 times the normal in both forward and reverse directions)

- Dimensions (WHD): 146 x 67 x 238 mm (5-3/4" x 2-11/16" x 9-3/8") • Weight: 1.8 kg (4 lbs.)

RM-70U Remote Control Unit **\$370.00**

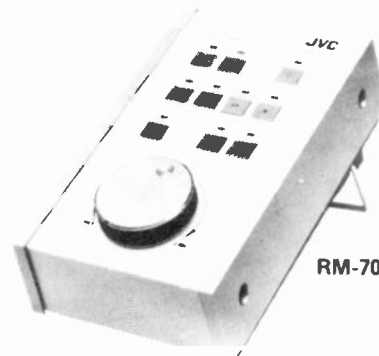

RM-70U

Ideal for High and Low Speed Screening of picture and sound

#### JVC Tape Handler System Prices

CP-5500U + RM-70 Screening System	<b>\$3100.00</b>
CR-6600U + RM-70 Screening System	<b>4030.00</b>
CR-8200U + RM-70 Screening System	<b>5370.00</b>
CP-5500U + RM-88 + CR-8200U Editing System	<b>10,950.00</b>
CR-6600U + RM-88 + CR-8200U Editing System	<b>12,000.00</b>
CR-8200U + RM-88 + CR-8200U Reversible Edit System	<b>13,800.00</b>
VE-90 Joystick Controller with provisions for single and dual monitors. (Sold only as part of the following complete systems.)	
CP-5500U + VE-90 + CR-8200U	<b>13,150.00</b>
CR-6600U + VE-90 + CR-8200U	<b>14,000.00</b>
CR-8200U + VE-90 + CR-8200U	<b>16,000.00</b>

3/4" VCR ACCESSORIES		PRICE
KR-503BU	Channel 3 color RF converter	For CP-5000U <b>\$100.00</b>
KR-504BU	Channel 4 color RF converter	
KR-505BU	Channel 5 color RF converter	
KR-506BU	Channel 6 color RF converter	
KR-234U	Switchable channel 3 & 4 color RF converter	CP-5200U CP-5500U For CR-6300U <b>100.00</b>
KR-256U	Switchable channel 5 & 6 color RF converter	CR-6060U CR-4400U
Remote control with 18 ft. cable for CP-5000/5200, CR-6300, Model RM-51U		<b>110.00</b>
RM-60U	Remote control for CR-6060U	<b>165.00</b>
SW-200UF	Switchbox and antenna cable for CR-6060U	<b>15.00</b>
MCB-20	Carrying case for use with CP5200U, CP5000U, CR6060U, CR6300U	<b>269.00</b>
VC-202U	Monitor cable for CP5000/CP5200/CR6300/CR6060/CR8500	<b>25.00</b>
RM-50U	10' Version of RM51U	<b>60.00</b>

# JVC

US JVC Corp.

PROFESSIONAL VIDEO DIVISION



CR-6600U



CR-8200U

## 3/4" COLOR VIDEOCASSETTE RECORDER

### CR-6600U

#### 3/4" Color Videocassette Recorder

\$3600.00

- Excellent dubbing quality due to FM-FM dubbing capability
- Ideal for use as a copying or editing VTR for software production
- Automatic pre-roll mechanism and blanking switcher enables assemble-editing
- Microcomputer-assisted logic control
- High reliability, stability and durability
- Variable-speed shuttle-search function via optional RM-70U, VE-90 or RM-88U
- Audio level controls with meters
- Audio limiter circuit built-in
- External-lock playback
- Time base corrector connectable
- Electronic tape counter/timekeeper
- Dimensions (WHD): 564 x 221 x 471 mm (22-1/4" x 8-3/4" x 18-9/16")
- Weight: 30.3 kg (67 lbs.).

The Direct Drive CR-6600U in conjunction with the new CR-8200U editing videocassette recorder and the new RM-82U and RM-88U Automatic Editing Control Units is part of a flexible mid-priced editing system that can be easily expanded or upgraded.

The CR-6600U has direct-drive head drum and capstan, as well as direct-drive reel motors on the reel servo system. This insures stable tape transport at any speed in either forward or reverse. Luminance jitter is rated at less than a factor of plus/minus 5 microseconds.

#### Features

- The CR-6600U has a built-in automatic pre-roll mechanism and blanking switcher, so that manual or remote control of the record and pause functions create clean assemble edits. The unit has an audio limiter circuit for each of two audio channels, which functions either automatically or manually. Dual audio recording level meters are provided.
- External subcarrier input terminal for TBC connection, and a variable-speed dial search control, which can continuously vary playback speed from zero to five-times normal in both forward and reverse when used with the RM series Automatic Remote Editing Control Units.
- Microprocessor-based logic tape controls, automatic rewind and repeat, pause control, a switchable electronic tape counter and standard time clock with digital display, and a counter search mechanism for locating selected portions of a tape. The unit also has FM-to-FM dubbing capability for improved picture quality during tape duplication.
- The CR-6600U has a video signal-to-noise ratio of more than 48 dB, and a horizontal resolution of 330 lines monochrome and 240 lines in color.

### CR-8200U

#### 3/4" Color Videocassette Recorder

\$5600.00

- Fully electronic editing with rotary erase heads and blanking switcher
- Excellent dubbing quality due to FM-FM dubbing capability
- Insert, assemble and pre-roll edit capabilities
- High reliability, stability and durability thanks to direct-driven head drum and capstan, reel servo system with exclusive reel motors, aluminum diecast chassis, two-motor gear-driven, tape loading system, etc.
- Remote control via optional RM-70U or automatic editing control via optional VE-90 or RM-88U
- Microcomputer-assisted logic control
- External-lock playback
- Time base corrector connectable
- Audio level control
- Electronic tape counter/timekeeper
- Dimensions (WHD): 564 x 221 x 471 mm (22-1/4" x 8-3/4" x 18-9/16")
- Weight: 30.3 kg (67 lbs.).

The tape transport performance of the CR-8200U color U-type editing videocassette recorder is the logical choice for video users that demand professional performance at a good price.

#### Features

- The CR-8200U has direct-drive head drum and capstan, as well as direct-drive reel motors on the reel servo system. This results in stable tape movement at any speed. Luminance jitter is rated at less than plus/minus 5 microseconds.
- The CR-8200U's rotary erase head and blanking switcher permit clean assemble and insert edits. An audio limiter circuit is provided for each of the two audio channels, preventing distortion in the audio recording process. This limiter circuit is manual or automatic. Dual audio recording level meters are also built-in.
- An external subcarrier input terminal is provided for TBC connections. The FM output and input allow for tape Duplication with low-distortion.
- When used with the RM-70U Remote Control Unit or either of the Edit Controllers in the RM series, the CR-8200U also has continuously variable playback speeds. These speeds vary from zero to five-times normal in both forward and reverse.
- Microprocessor-based logic tape controls, automatic rewind and repeat, pause control, and a switchable electronic tape counter and standard time clock with digital display. There is also a counter search mechanism for finding specific portions of a program.
- The CR-8200U has a video signal-to-noise ratio of more than 48 dB, and a horizontal resolution of 330 lines monochrome and 240 lines in color.

# JVC

US JVC Corp.

PROFESSIONAL VIDEO DIVISION

## JVC's all-new U-format portable: reliability and performance make it invaluable for ENG/EFP applications



### CR-4700U

- Lightweight — 19.6lbs. w/Battery • Low Power Drain — 12.5 watts
- Real Time Monitoring • Record Current Adjustment • Microprocessor Controlled • Remote Control • SMPTE Time Code Capability • Frame Servo Mechanism • Automatic Backspace Edits • Real Time Tape Counter (Min/Sec) • Shuttle Search — 10X Speeds
- Battery Meter • Six Warning/Status Lamps & Beep • Twin Audio Level Meters • Switchable Audio Monitoring • Soft Eject Mechanism
- SYNC & Subcarrier Jacks • PRO Connections (BNC -A3/XLR)

## 3/4" RECORDING SYSTEMS

### Specifications

• Format: U-standard • Video Recording System: Rotary two-head, helical scan system • Video Signal System: NTSC-type color, 525 lines • Maximum Recording Time: 20 min. (KCS-20) • Tape Speed: 9.53 cm/s • Power Requirements: 12 V DC • Power Consumption: 12.5 watts • Temperature: Operating: 0°C to 40°C (32°F to 104°F) Storage: -20°C to 60°C (-4°F to 140°F) • Operating Position: Horizontal or vertical • Video Signal — Input: 0.5 V to 2.0 Vp-p, 75 ohms, unbalanced; Output: 1.0 Vp-p, 75 ohms, unbalanced; Signal-to-noise Ratio: More than 46 dB (Rohde & Schwarz noise meter); Horizontal Resolution: More than 260 lines; SC Input: 2.0 Vp-p, 75 ohms, unbalanced; Sync Input: 4.0 Vp-p, 75 ohms, unbalanced • Audio Signal — Input: Mic -60 dBs, 10 k-ohms, balanced; Line -20 dBs/-60 dBs, 10-k ohms, balanced; Output Level: 0 dBs, low impedance, balanced; Headphone Output: Variable between -20 and -40 dBs, 8 ohms load, unbalanced; Signal-to-noise Ratio: More than 48 dB; Frequency Response: 50 Hz to 15,000 Hz • Time Code: input: More than 1 Vp-p, 10 k-ohms, unbalanced; Output: 2.2 Vp-p, low impedance, unbalanced • Connectors — Video/SC/Sync input/output: BNC; Audio LINE IN/OUT: XLR; Mic: LINE IN connectors are used for connecting microphones; Headphones: 6 mm jack; Time code input/output: 12-pin connector • Dimensions: 338(W) x 130(H) x 352(D) mm (13-5/16" x 5-1/8" x 13-7/8") • Weight: 8.9 kg (19.6 lbs.) (with NB-P2U Battery Pack and a KCS-20 video cassette) • Accessories: NB-P2U Battery Pack, Carrying Handle, Shoulder Strap

### CR4700U

\$4250.00

### Accessories:

AAP-47U	AC Adapter/Charger	\$370.00
NB-P2U	Rechargeable Battery	100.00
TG-P47U	Time Code Generator	Call for Price
CB-XX	Custom Shoulder Case	Call for Price
RMP-47	Remote Control	245.00
BA-P47U	Ext. Battery Cord for NB-P2	170.00

### KCR-2747

KY2700A Camera/VCR Combination \$12,500.00  
Recording System Consists of Portable KY-2700APS System with Standard Accessories (Less Lens), CR47006 and AC Adaptors

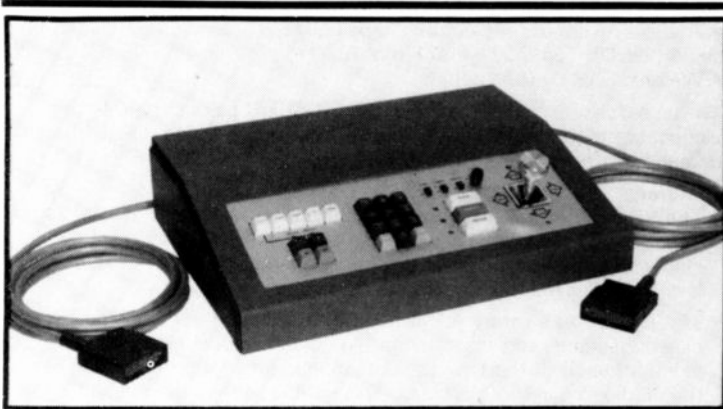

### VE-90 Videotape Editor

The microprocessor-based VE-90 videotape editor with the efficiency and precision of joystick control is the centerpiece of three new editing systems available from the Professional Video Division of US JVC Corp. With continuously variable tape speed and single-handed control, the VE-90 operates on control track. It is compatible with 3/4" and professional 1/2" VCRs, and comes configured with Tapehandler players and recorders. The VE-90 is engineered for fast, hassle-free editing. And it is the first joystick-controlled editor from JVC especially suited for ENG, educational, corporate and professional editing applications.

### Full-Function Editor

With the versatile VE-90, the operator can edit onto a blank videotape (assemble) or onto a prerecorded tape (insert).

The VE-90 also lets the operator perform one-second fades to and from black, and generates NTSC black ("crystal black"). The black generator function is convenient for adding a control track and recording NTSC black for insert editing.

Other VE-90 features include High Speed Search, which enables the operator to find an exact tape location, and Cruise, which shuttles the tape at the fastest joystick speed in forward or reverse. Auto-Tag automatically loads the last record-out point as the next record-in point is completed, minimizing keystrokes and maximizing efficient program building. Recall allows the operator to call up the last keyboard entry for reference or correction before an edit is initiated, while Swap provides access to alternate VCR controls. A Status Display Generator provides a signal to an external monitor of important editing data including: edit number, tape time, record and source in/out points, edit durations, type of edit, VCR status and more.

- Weight: 17 lbs. VE-90 only
- Dimensions: 17" W x 4.5" H x 13" D

### VE-90 Editor sold in the following packages only

VE-90 Editor with two CR-8200s	\$16,000.00
VE-90 Editor with CR-8200 and CR-6600	14,000.00
VE-90 Editor with CR-8200 and CR-5500	13,000.00

# JVC

US JVC Corp.

PROFESSIONAL VIDEO DIVISION

## 1/2" COLOR VIDEOCASSETTE PLAYER/RECORDERS

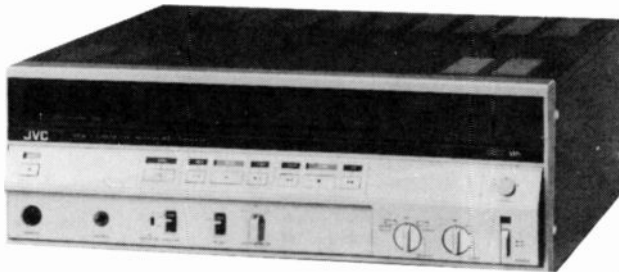

BP-5300U



BR-6400U

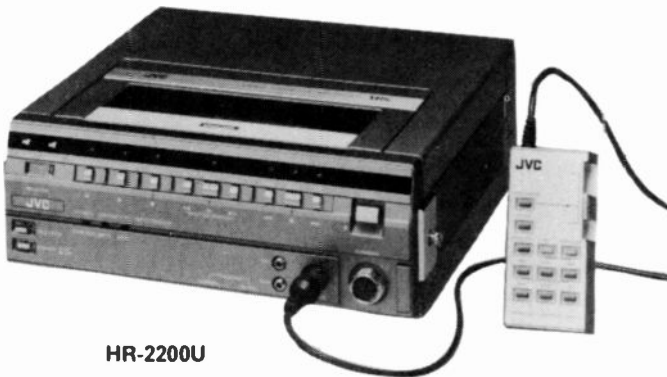

HR-2200U

### HR-2200UB VHS-Format 1/2" Color Videocassette Recorder

- Microprocessor-based full-logic tape control
- Solenoid-operated feather-touch pushbuttons
- Four-motor system for greater stability and high reliability
- Variable-speed playback — variable slow-motion, still-frame and frame-advance
- Shuttle search function for quick program sequence location in both directions
- Eleven-mode full-function remote control unit
- ESC (Edit Start Control) system for smooth assembled recordings
- A separate optional tuner doubles as an AC power adaptor/battery charger.

The microprocessor in the HR-2200UB makes possible remote control operation of 12 modes, including recording, variable slow motion, freeze frame, frame advance and others.

This ultra-lightweight, compact portable recorder weighs only 14.0 lbs. complete with battery pack. This makes it one of the lightest color videocassette recorders around. But it's not just the light weight of the HR-2200UB that makes it so portable; it's also very compact — its biggest dimension is less than a foot.

The HR-2200UB retains VHS compatibility with picture and sound quality, with simple operation and tape loading.

The operation of the HR-2200UB requires only 9.6 watts. Further power saving is possible using the recording standby mode lock switch which switches power off while still allowing smooth transition between separately recorded segments.

- Dimensions (WHD): 338 x 137 x 329 mm (13-3/8" x 5-7/16" x 13")
- Weight: 14.0 lbs.

**HR-2200UB** 1/2" Color Videocassette Recorder **\$1100.00**

### BP-5300U VHS-Format 1/2" Color Videocassette Player

- Four-head system for improved picture quality in special effect playback modes
- Direct-drive system for stable playback
- Aluminum diecast chassis for heavy-duty use
- Motorized automatic front cassette loading
- Microprocessor-based full-logic control
- Shuttle search to about 10 times normal speed
- Capstan servo and external sync capability
- Two-channel audio
- Flexible search and repeat functions
- Electronic tape counter/lap time indicator
- Cordless remote control (RM-P54), connectable remote control (RM-P53), and random access unit (RM-P500) are available.
- Variable-speed playback from still to 10 times normal in either direction when remote-controlled
- Dimensions (WHD): 442 x 165 x 447 mm (17-7/16" x 6-1/2" x 17-5/8")

**\$1400.00**

### BR-6400U VHS-Format 1/2" Color Videocassette Recorder

- Four-head system for improved picture quality in special-effect playback modes
- Direct-drive system for stable recording and playback
- Aluminum diecast chassis for heavy-duty use
- Motorized automatic front cassette loading
- Microprocessor-based full-logic control
- Shuttle search to 10 times normal speed
- Capstan servo and external sync capability
- Two-channel audio with selectable audio dubbing
- Audio level control with meters
- Automatic back-space editing control
- Electronic tape counter/lap time indicator
- Cordless remote control (RM-P54), connectable remote control (RM-P53) and random access unit (RM-P500) are available.
- Variable-speed playback from still to 10 times normal in either direction
- Dimensions (WHD): 442 x 165 x 447 mm (17-7/16" x 6-1/2" x 17-5/8")

**\$1785.00**

# JVC

US JVC Corp.

PROFESSIONAL VIDEO DIVISION

## MONITOR/RECEIVERS



7860UM



TM-41AU

### 7280UM/7860UM

#### 13"/19" Diagonal Color TV Monitor/Receivers

The 7280UM/7260UM color TV monitor features electronic components which have been checked and re-checked during production to guarantee superior performance over a long and trouble-free lifetime.

##### Features:

- Black Matrix Picture Tube
- Scene Control
- Automatic Fine-tuning Control (AFC)
- Easy Front Panel Switching between TV and VCR/VTR playback
- Two earphone jacks for private listening or audio monitoring
- Aperture Compensator Control (APACON) on the 7860UM
- Automatic Picture Control (PICTURE AUTO) on the 7280UM
- Automatic Picture Control (PICTURE TUNE) on the 7860UM
- Record off-the-air TV programs with excellent picture quality
- Video tape playback quality ensured by a full set of controls
- Monitor the camera signal on the TV screen
- Enjoy Hi-Fi sound through a separate audio system
- All solid state construction

##### 7280UM

13" Diagonal Color Monitor/Receiver with VC-202U Monitor Cable

**\$715.00**

##### 7860UM

19" Diagonal Color Monitor/Receiver with VC202U Monitor Cable

**\$890.00**

### TM-41AU

#### 5" Portable Color Video Monitor

JVC announces the 5-inch color video monitor which can be used in a variety of video systems. Being lightweight and having three power supply options — AC, battery pack and car battery — it's most suitable for checking camera work in combination with a portable Vidstar VHS system. The TM-41AU has been designed for flexible applications and can be used for professional ENG/EFP productions as well as in studios where a small color camera monitor is required in conjunction with a control console.

- A 5-inch (12.58 sq. in.) in-line stripe picture tube ensures reproduction of sharp, clear color images.
- Flexible 3-way power supply arrangement — household AC, exclusive rechargeable battery pack or car battery — enables both indoor and outdoor use.
- Speaker incorporated for monitoring audio.
- Two video inputs and two audio inputs are provided. Either one can be selected by the pushbuttons on the front panel.
- An LED indicator warns of low battery power.
- The exclusive rechargeable battery pack PBP-1 (optional) can be recharged through the AC power adapter AA-P41AU (optional) while remaining within the monitor.
- The bridged and selected outputs are available from the rear panel terminals with both video and audio signals.
- EIAJ 8-pin connector is provided.

##### TM-41AU

5" Diagonal AC/Battery Powered Color Monitor (PBP-1 battery optional)

**\$395.00**

##### AAP-41AU

Battery Charger for PBP-1

**\$125.00**

# JVC

US JVC Corp.

PROFESSIONAL VIDEO DIVISION

## COLOR TELEVISION MONITOR

### CX-610

#### 5" Diagonal—13 Sq. In.

#### 5-Inch Portable Color TV and Monitor

• Sharp, vivid color pictures on both VHF and UHF from a compact, lightweight unit • Four-way power supply flexibility—AC, "D" batteries, optional rechargeable battery pack and car battery via optional adaptor • Contactless electronic tuner • High-sensitivity swivel telescopic antenna • AFC (Automatic Fine-tuning Control) • Precision in-line electronic guns • Video In-Out terminals for use as a color video monitor or as a tuner for recording off-air TV programs with a portable video recorder • Dimensions: 244 W x 135 H x 275 D mm (9-5/8" x 5-3/8" x 10-7/8") • Weight: 4.4 kg (9.7 lbs.) (w/o batteries) **\$450.00**



CX-610

#### Accessories

BC-60E	Battery case	\$27.00
CB-25E	Rechargeable battery pack	\$107.00
CC-60E	Carrying case	\$34.00
AP-23	Car Adaptor	\$7.00

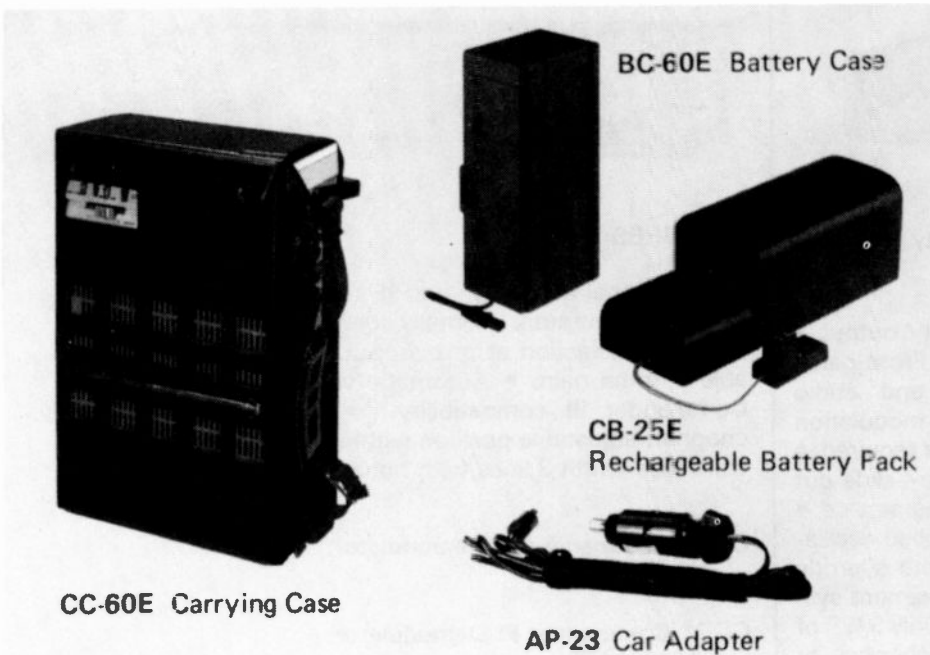

## SPECIFICATIONS

TV standard NTSC system US Standard  
Channel coverage VHF channels 2 – 13,  
UHF channels 14 – 83  
Picture tube 5-inch (picture measured  
diagonally), 55° defl. angle, flat-surface,  
precision in-line tube.  
Power input AC 120 V, 60 Hz, DC 12 V (Car  
battery/Rechargeable battery), DC 15 V  
(with 10 D-size dry-cell batteries)  
Power consumption 14 W at DC, 24 W at AC  
Audio output 0.6 W max.  
Antenna input Telescopic rod antenna,  
75-ohm for VHF and 300-ohm for  
VHF & UHF with matching adapter.  
Speaker size 8 cm (3-1/4")  
Jacks AC input jack, Battery input jack  
(for dry-cell & rechargeable battery),  
12 V DC input jack (for car adapter),  
Earphone jack, Video input jack,  
Audio input jack, Video output jack,  
Audio output jack.  
Dimensions 244(W) x 135(H) x 275(D) mm  
(9-5/8" x 5-3/8" x 10-7/8")  
(excluding handle)  
Weight 4.4 kg (9.7 lbs.) (without batteries)



## Television Demodulator, Model UD-283A

For MATV, CCTV and CATV Applications

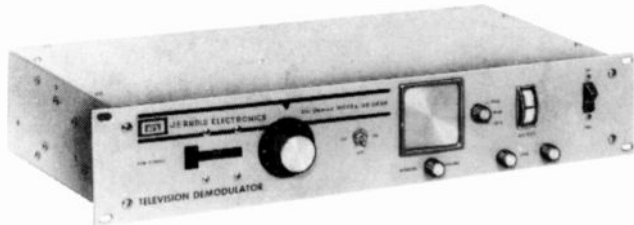

Provides High Quality Composite Video and Audio Signals from any TV Channel (2-83)

### FEATURES

- All Channel • Precise Repeatable Tuning • Front Panel Metering • AFT • Varactor Solid State Tuning • Quality Color & Black & White Signals • Simultaneous Monitoring and On-Line Operation • AGC

## Commander III Modulator Model CMM\*

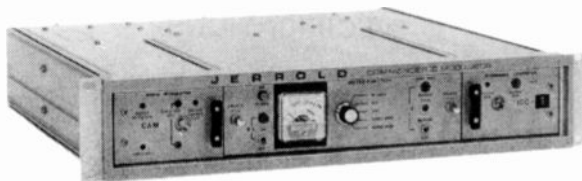

TV Signal Modulator for broadcast quality adjacent channel operation, monochrome or color.

### FEATURES

- Spurious outputs down -70 dB at +60 dBmV output • Extremely low differential phase and gain • Front-panel metering for video depth of modulation and audio deviation • White-level limiter prevents over-modulation • Front-panel test points • No outboard filters required • Automatic gain control • Ease of maintenance—slide-out drawer allows maintenance without interrupting service • Plug-in modular construction • Crystal-controlled oscillator with new pulse-integrating AFC • Complete override control for emergency alert • Provides for maximum system reliability with external standby power • Only 3 1/2" of rack space • Optional phase lock: single channel or incremental

**CCM\* Commander III Modulator,**  
Output VHF (2-13)

**CMM\* Commander III Modulator,**  
Output Sub (T-7 - T-11), Mid, Super (A-W)

\* Specify Channel

## Audio-Video Modulator

**uni-mod™**  
Adjacent Channel  
Modulator

**NEW HIGH OUTPUT +62 dBmV**  
... plus 80 dB shielding



Now Available for Sub and Mid-Band.  
**UM\***

### FEATURES

- Monochrome or Color Operation • Front Panel Control and Metering of Aural and Visual Modulation • Adjacent Channel Operation Made Possible by Unique Helical Resonator Bandpass Filter • Crystal Controlled Visual Carrier • 4.5 MHz Aural Offset Automatic Frequency Controlled with Integrated Circuitry
- \* Specify Standard VHF, Sub or Mid-Band Channels

## Commander III Demodulator Model CDD-\*

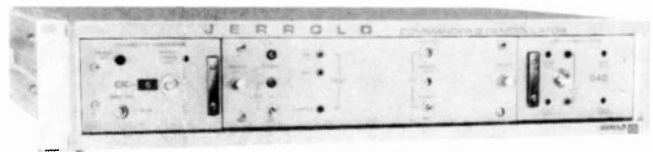

### FEATURES

- Front-panel audio, RF and IF test points. • Two rear-panel video outputs; internally combined 4.5 MHz available by switch selection at one output. • Front panel adjustable chroma gain. • Automatic video/sound squelch. • Commander III compatibility. • Modulation reference chopper: adjustable position within vertical blanking interval. Pulse width 3 lines with horizontal sync. unblanking.

**CDD\* Commander III Demodulator,**  
VHF (2-13)

**CDD\* Commander III Demodulator,**  
UHF (14-83)

**CDD\* Commander III Demodulator,**  
Sub (T-7 - T-13), Mid (A-1, Super (J-W) . . . \$2170.00





# PORTA-BRACE™

K and H Products, Ltd.

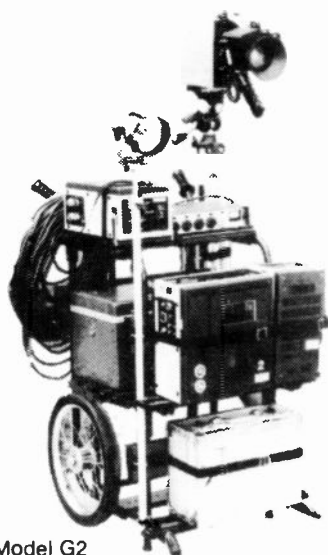

Model G2  
showing light stand and tripod in quiver

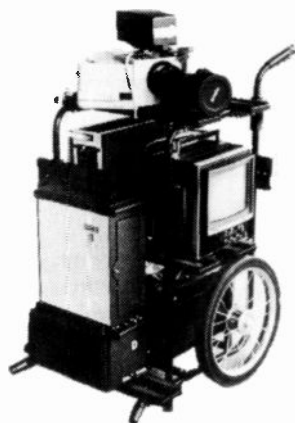

Model G2



Trim Series

## CARRYING EQUIPMENT FOR PORTABLE VIDEO

### Porta-Brace™ Grip

The GRIP is a heavy-duty, adjustable video cart. It transports more video equipment than ever before possible. The GRIP can be used in the studio or in the field; it is compact and can be loaded into a station wagon and yet may be custom-adjusted to accommodate a wide variety of studio or field equipment. Equipment may be semi-permanently secured by a unique strapping system or may be secured with shock cord for quick on-off use. All bearing surfaces are neoprene padded for shockproof transport. The GRIP uses sturdy 16" spoked wheels, and its axle frame adjusts for selecting the exact balance for your load. The standard model has a cushioned camera rack conveniently located near the handle grips for safe carrying. A second set of handles is provided in front for two-person lifting. The standard GRIP G-1 comes complete with strapping system, shock cord and camera rack. Overall size approx. 25" x 26" x 36" high. Weight: 45 lbs.

Extra Large Model G2 has all the features of the standard model GRIP but with an extra second tier cushioned-shelf arrangement. This added structure nearly doubles the space capacity by adding a full upper surface and another front overhanging shelf.

#### ACCESSORIES:

**CASE**—Model G-LCA, large catchall case which will carry all kinds of tapes, mikes, clamps, cords, etc. It has a thick padded, nylon squared-off construction. Main compartment is 5-1/2" x 11" x 13", two side pockets 3" x 4-1/2" x 12", and one front pocket 2" x 9-1/2" x 11-1/2". Hooks between handles.

**CASE**—Model GU, two-compartment nylon zippered utility case. This case hangs in the space between the axles or higher, between the handles.

**QUIVER**—Model GQ-S or GQ-L tripod quiver holds snugly a tripod for transporting with or without camera. Tripod may be quickly removed or left in place for shooting. Specify type of tripod to be held: Model No. GQ-S = small, or Model No. GQ-L = Large.

**LIGHT STAND**—Model GL, telescoping light stand is fixed on the GRIP. Available for single or double light source.

### "Grip" Heavy-Duty Cart and Accessories

Model #	Application	Price
G-1	Multi-Purpose	\$410.00
G-2	Multi-Purpose, Extra Capacity	435.00
G-L	Field Production Lights, 1/2" Top Stud	48.00
G-QL	For Large Tripods	45.00
G-QS	For Smaller Tripods	45.00
G-U	Utility Case	45.00
G-LCA	Large Utility Case	68.00

### The Porta-Brace™ Trim Series

The Trim Series is offered for those who wish to carry a recording deck on the back without a camera support. It is a compact, comfortable back frame with padded waist belt and shoulder straps. The recorder case sets on small shelves and is secured by clevis pins and split rings. This unit can be put on the wheelbase (WB-2) for rolling. It does not include camera arm or accessory case though these items may be ordered separately. Order by designating "T" plus recorder used plus WB-2 Wheelbase if desired. (Example: T3800/WB-2).

Backpack-Trim Series	With Wheelbase	Without Wheelbase
Model #	Price	Price
T-50	\$309.00	\$244.00
T-50B	320.00	255.00
T-110	314.00	249.00
T-150	296.00	231.00
T-170	296.00	231.00
T-340	296.00	231.00
T-2100	296.00	231.00
T-2200	298.00	233.00
T-3000	298.00	233.00
T-3400	225.00	160.00
T-3800	309.00	244.00
T-3800B	320.00	255.00
T-4100	296.00	231.00
T-4400	307.00	242.00
T-4400B	320.00	255.00
T-4800	311.00	246.00
T-7300	296.00	231.00
T-8400P	309.00	244.00



## BASE, FILL AND SET LIGHTS

ALL UNITS PROVIDED WITH 36 INCH LEADS, C-CLAMP,  
SAFETY CABLE AND CONNECTOR

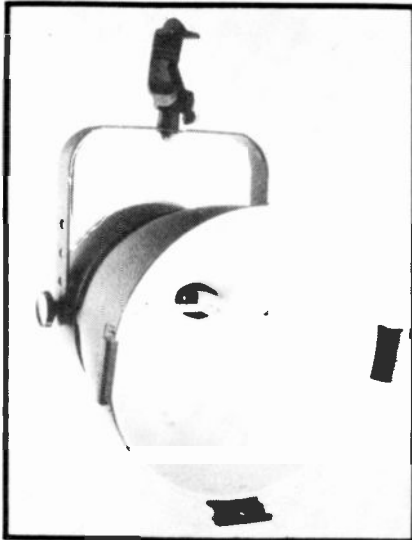

3451TV

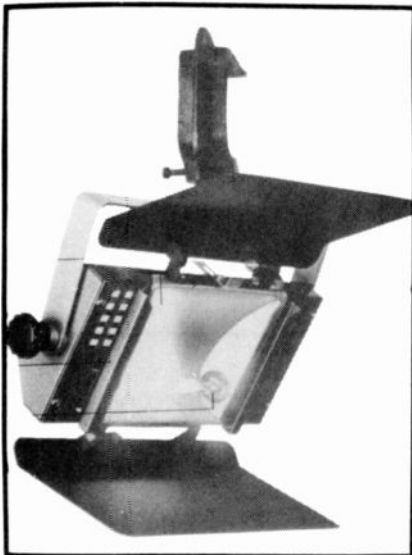

1000SE

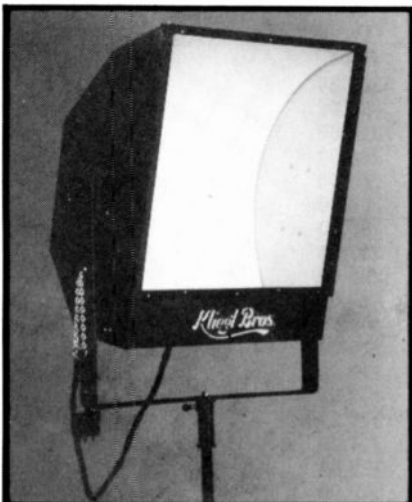

6914TV

CATALOG NUMBER	DESCRIPTION	PRICE
3451	16" 1000W Quartz Scoop	140.00
3452	16" 1000W Focusing Quartz Scoop	190.00
13451	Color Frame	35.00
13452	Color Frame	35.00
	QUARTZ LAMPS FOR 3451TV/3452TV:	
	FDN 500W 3200°K 400 hrs. frosted	29.00
	EMD 750W 3200°K 400 hrs. frosted	40.00
	FHM 1000W 3200°K 300 hrs. frosted	33.00
1000SE	1000W Quartz Set Light	\$190.00
	QUARTZ LAMPS FOR 1000 SE:	
	FDN 500W 3200°K 400 hrs. frosted	29.00
	EMD 750W 3200°K 400 hrs. frosted	40.00
	FHM 1000W 3200°K 300 hrs. frosted	33.00
6912	2000W Soft Light	600.00
16912	Color Frame	60.00
	QUARTZ LAMPS FOR 6912TV:	
	FHM 1000W 3200°K 300 hrs. frosted	33.00
6914	4000W Soft Light	600.00
16914	Color Frame	60.00
	QUARTZ LAMPS FOR 6914TV:	
	FFW 2000W 3200°K 125 hrs.	63.00
<b>DIFFUSION MATERIALS</b>		
CATALOG NUMBER	DESCRIPTION	PRICE
TSP-2	Tough Spun. Replaces spun glass. Roll 48" x 25 feet.	\$130.00
TRF-2	Tough Frost Diffusion	130.00
TSK-2	Tough Silk. Same diffusion qualities as real silk. Roll 4' x 25'	130.00
835	Spun glass. Roll 3' x 12'	30.00
NOTE: Softlights require 2 lamps each.		

ADD SUFFIX TO CATALOG NUMBER TO SPECIFY  
PROPER CONNECTOR

- UG Parallel blade U-ground, U.L. listed
- 955G 3 pole pin connector, U.L. listed
- TLG 3 pole twistlock, U.L. listed





## KEY AND BACK LIGHTS



3604TV



3606TV



3610TV

ALL UNITS PROVIDED WITH 36 INCH LEADS, C-CLAMP, SAFETY CABLE AND CONNECTOR

CATALOG NUMBER	DESCRIPTION	PRICE
3604	4 1/2" 750W quartz Fresnel, slide focus	\$150.00
23604	4 way Barndoor	70.00
13604	Color Frame	8.00
	QUARTZ LAMPS FOR 3604TV:	
	BWM 750W 3200°K 200 hrs.	71.00
3606	6-3/8" 750W Quartz Fresnel	170.00
23606	4 way Barndoor	70.00
13606	Color Frame	9.00
	QUARTZ LAMPS FOR 3606TV:	
	EHC 500W 3200°K 500 hrs.	49.00
	EHF 750W 3200°K 300 hrs.	54.00
3608	8" 1000W Quartz Fresnel	280.00
23608	4 way Barndoor	80.00
13608	Color Frame	10.00
	QUARTZ LAMPS FOR 3608TV:	
	CYV 1000W 3200°K 200 hrs.	83.00
	CXZ 1500W 3200°K 325 hrs.	105.00
	CYX 2000W 3200°K 250 hrs.	114.00
3609	8" 1000W Quartz Fresnel	265.00
23609	4 way Barndoor	80.00
13609	Color Frame	10.00
3610	10" 2000W Quartz Fresnel	390.00
23610	4 way Barndoor	130.00
13610	Color Frame	13.00
	QUARTZ LAMP FOR 3610TV:	
	CYX 2000W 3200°K 250 hrs.	114.00
3612	12" 5000W Quartz Fresnel	400.00
23612	4 way Barndoor	165.00
13612	Color Frame	19.00
	QUARTZ LAMP FOR 3612TV:	
	DPY 5000W 3200°K 500 hrs.	453.00
3616	16" 10000W Quartz Fresnel	P.O.A.
23616	4 way Barndoor	P.O.A.
13616	Color Frame	P.O.A.
	QUARTZ LAMP FOR 3616TV:	
	DTY 10000W 3200°K 300 hrs.	878.00

NOTES: Oval Beam® 8" Fresnels available on Special Order

Pole-operated Fresnels available on Special Order

P.O.A. — Price On Application

ADD SUFFIX TO CATALOG NUMBER TO SPECIFY PROPER CONNECTOR

- UG Parallel blade U-ground, U.L. listed
- 955G 3 pole pin connector, U.L. listed
- TLG 3 pole twistlock, U.L. listed





## SIX STUDIO LIGHTING PACKAGES

These packages have been designed and engineered by Kliegl to cover a broad spectrum of studio lighting applications as they apply to most commercial, educational, and industrial users. Each package has been carefully laid out to ensure that the compliment of lighting fixtures, distribution equipment and the lighting control system will prove adequate in the area for which it is designed.



LIGHTING FIXTURES

**LIGHTING FIXTURES** — A varying compliment of Key, Back, Base, Fill and Set lights, including their accessories, are provided in every package. Pattern Projectors and special Cyc lighting instruments are included in certain packages. All fixtures are provided with 36" leads, C-clamp, safety cable and connector.

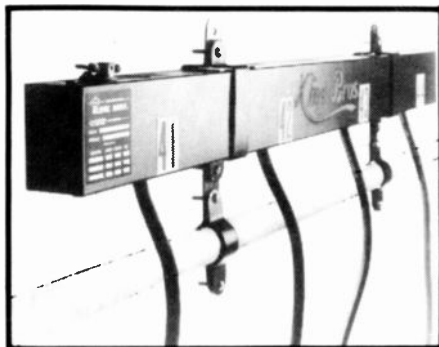

DISTRIBUTION EQUIPMENT

**DISTRIBUTION EQUIPMENT** — Wireway connector strips and wall outlet boxes are provided in various quantities for each package (except the STUDIO/FIELD Package, which uses a portable plugging box), in order to ensure proper power distribution throughout the specified studio. Cyc drop boxes are also used in the two larger packages for powering the cyc lighting units.

**LIGHTING CONTROL SYSTEM** — A solid state, low voltage control dimming system has been designed for each of the studio packages. Each system consists of an SCR Dimmer Bank, a Safpatch Panel, a portable 2 Scene Control Console and Plugging Box. The STUDIO/FIELD Package has the option of using a KLIEGPAC 9 portable dimming system in place of the portable Plugging Box normally provided.

In addition to the above, each of the studio packages contain a studio layout, the power requirements of the package, and a system (flow) diagram. The packages are listed as follows:

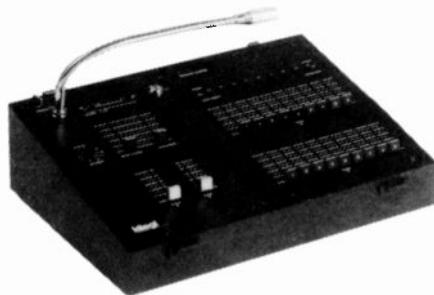

LIGHTING CONTROL SYSTEM

CATALOG NUMBER	PACKAGE DESCRIPTION	PRICE
801015	10 x 15 TV Package	\$ 2,900.00
801520	15' x 20' (300 sq. ft.)	15,500.00
801825	18' x 25' (450 sq. ft.)	23,000.00
802030	20' x 30' (600 sq. ft.)	32,000.00
803040	30' x 40' (1200 sq. ft.)	70,000.00
804060	40' x 60' (2400 sq. ft.)	110,000.00



Kliegl is also available to work with you in the custom design of a lighting control and distribution system to meet you studio needs. Please contact your Kliegl video dealer, sales representative or the factory direct, in order to arrange for a no-obligation review of your studio requirements.

### Standard Systems (Include Dimmer Bank, Control Console and Control Cable)

System #	Description	Dimmer Bank #	Control Console #	Price \$
7000/TLG	9 – 2.4 KW Dimmers. Twistlock Receptacles	7926/TLG	7890	5,400.00
7000/9555G	9 – 2.4 KW Dimmers. Pin Connector Receptacles	7926/955G	7890	5,400.00
7000/UG	9 – 2.4 KW Dimmers. U Ground Receptacles	7926/UG	7890	5,400.00
7000/S	9 – 2.4 KW Dimmers. Terminal Strip Output	7926/S	7890	4,975.00
8000/955G	9 – 6.0 KW Dimmers. Pin Connector Receptacles	7960/955G	7890	9,100.00
8000/S	9 – 6.0 KW Dimmers. Terminal Strip Output	7960/S	7890	8,175.00

NOTE: A #7892/32 Control Cable is furnished with each system.

#### Control Cables



Catalog #7892  
Console to Dimmer Bank  
Control Cable

32" (10M) long with AMP connectors

Catalog #7893  
Console to Console  
Master/Slave Cable

3' (1M) long with AMP connectors

Catalog #7895  
Cable to Cable Coupler  
1' (3M) long with AMP connectors

Other Control Cable lengths of 50, 75, 100, 200 and 250 ft. also available. External plug-in boxes for solid connected systems #7888 with 2 receptacles and #7889 with 1 receptacle also available. All products UL listed.





# KLOSS VIDEO

NOVABEAM

## NOVABEAM MODEL ONE

The NOVABEAM Model One is a two-piece projection color television set, consisting of an unusually compact receiver/monitor console and a separate free-standing screen which provides a 6.5' diagonal-measure picture. Like most other quality home projection sets, the picture is projected by a three-tube system which eliminates the electrical inefficiencies of the conventional front view color picture tube like the shadow mask and the uncontrolled direction of light. However, the NOVABEAM Model One incorporates innovative new NOVATRON™ projection tube technology which achieves a new level of picture performance — and does so, almost incidentally, at a lower cost than was previously possible. We believe that the result is a projection set which will come closer to fulfilling your expectations for large-screen television viewing than any other.

## THE NOVATRON PROJECTION TUBE SYSTEM AND THE PROJECTION SCREEN

The key to the NOVABEAM Model One's high performance, as well as to its lower than expected cost, is the new NOVATRON projection tube developed by Kloss Video Corporation. It is overall the most efficient method yet devised to realize a large color television picture — efficient in its use of electricity, efficient in its light-projecting capability and efficient to manufacture.

NOVATRON tubes, one for each of the red, green and blue signals that make up a color TV picture; the three projected images overlap on the screen to create the full color picture free of the segmentation into dots or strips common to regular television.

Combined with the NOVATRON projection tube system is a new high performance projection screen. Its 6.5' diagonal surface focuses the light from the projector over a broad, comfortable viewing area, while simultaneously rejecting ambient room light; the surface is both durable and washable. Together, the screen and the NOVATRON projection system provide the brightest home projection television picture, one which can be watched in surprisingly well-lit surroundings. Available in Walnut or Oak finish.

## TEN FOOT FLAT SCREEN NOVABEAM®

The NOVABEAM® Model One 10 Foot Projector for use with a flat screen is intended for special applications in home, institutional, and industrial installations where projection on a larger, flat screen (with controlled room lighting) allows larger audience coverage. The NOVABEAM® Model One 10 Foot Projector is used with a conventional 6 x 8 foot, glass beaded or matte white, flat projection screen. The flat screen may be ceiling, wall, or tripod mounted; and electrically controlled roll up/out of sight installations are possible. Because the 10 foot diagonal flat screen is more than twice the area of the 6.5 foot diagonal curved screen, the flat screen reflects light over a wider viewing area than the curved screen and does not reject ambient room light as the curved screen does. Consequently, the NOVABEAM® 10 foot flat screen picture is not as bright as the standard NOVABEAM® 6.5 foot curved screen picture. NOVABEAM® 10 Foot flat screen brightness is comparable to classroom 16mm movie projection; similar, subdued lighting is appropriate.

The NOVABEAM® Model One 10 Foot Projector is also available in a ceiling mount version where suspending the projector from the ceiling is preferable to standard floor positioning. The projector has side mounted plates from which it is hung upside-down in a ceiling mounted frame which must be secured to the building structure. The projector has also been modified electronically to provide a "heads-up" picture and convergence control changes appropriate for the projector in the upside-down position.

## NOVABEAM® Model One Projection Receiver Monitor includes Tuner, Remote Control. Walnut or Oak cabinet.

	SCREEN Included	Floor Standing Model	Ceiling Mount Model
6 ½' Curved Screen Projector	Yes	\$3300.00	\$3800.00
6 ½' Flat Screen Projector	No	3125.00	3625.00
10' Flat Screen Projector	No	3500.00	4000.00

# LARGE SCREEN PROJECTION TV

(6 ½ and 10 Foot)

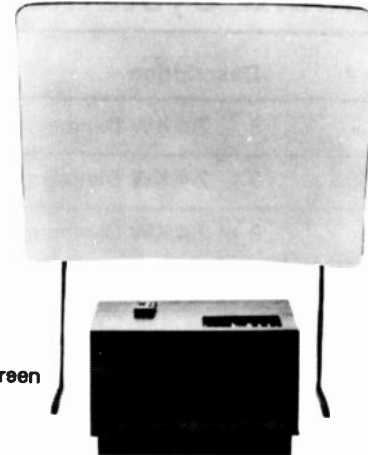

6 ½' Curved Screen Floor Standing Model Shown

## NOVABEAM® Model One Monitor only without Tuner. Vinyl Walnut Cabinet

	SCREEN Included	Floor Standing Model	Ceiling Mount Model
6 ½' Curved Screen Projector	Yes	\$2700.00	\$3200.00
6 ½' Flat Screen Projector	No	2525.00	3025.00
10' Flat Screen Projector	No	2900.00	3400.00

## NOVABEAM Model Two Video Projector Monitor Only

Flat Picture, without Tuner or remote control; Available Late 1982; Screen Not Included **Net \$2000.00**

### Accessories

Wall Mount Brackets for 6 ½' Curved Screen	\$20.00 pair
Curved 6 ½' Screen With Legs	\$425.00

NOTE: Custom Wall Mounting and Ceiling Installation Additional. Remote Control With 30' Cable \$150.00 Plus Installation

## FEATURES AND SPECIFICATIONS

**Projection System:** 3 NOVATRON projection tubes with f0.7 reflective optics and electromagnentic focusing.

**Projector Size:** 27.5" wide by 22" deep by 18.5" high (70cm x 56cm x 47cm).

**Picture Size:** 6.5' diagonal (4' x 5.5').

**Picture Brightness:** More than 80 foot-lamberts white highlight brightness on axis (more than 5 times the brightness recommended for commercial movie theater by the Society of Motion Picture and Television Engineers.)

**Circuitry:** All solid-state with comb filter for highest picture resolution.

**Tuning:** Digital pushbutton selection of all VHF and UHF channels (2-83) with all electronic random-access tuner; American NTSC signal standard. Wireless Remote Control Included.

**Special Controls:** In addition to the usual color TV operation controls, a test pattern generator and controls for adjusting the focus and convergence of the NOVATRON projection tube system are provided.

**Video:** 2 Video inputs plus tuner. Video inputs are for NTSC Video, 1 volt p-p and are 75 ohm terminated. 1 video output providing 1 volt p-p video into a 75 ohm load.

**Audio:** 2 line level audio inputs. 2 outputs, 1 line level and 1 variable by the volume control.

**Audio Output:** Jack provided to feed sound to separate hi-fi system or audio tape recorder.

**Other Program Sources:** Videocassette recorders, videodisc players, video games, and the like may be played through the antenna input, permitting remote switching.

**Antenna Input:** 300 ohms balanced or 75 ohms coaxial input for VHF, 300 ohms balanced for UHF. No antenna supplied.

**Power Requirements:** 125W, 120VAC, 60 Hz.

**Weight:** Projector packed = 125 lbs. Screen packed = 59 lbs. Projector unpacked = 118 lbs. Screen unpacked = 50 lbs.



# CHARACTER GENERATORS

Math, Greek and Foreign  
Language Symbols Included



K128B

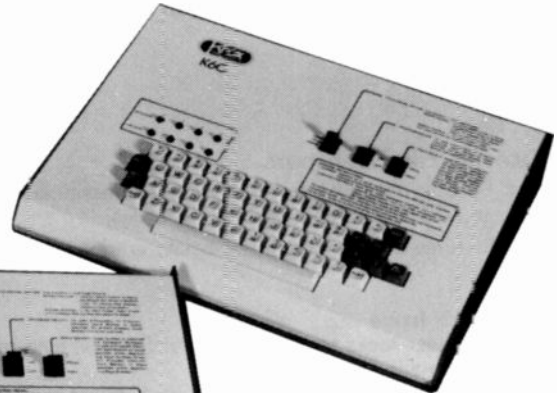

K50/60

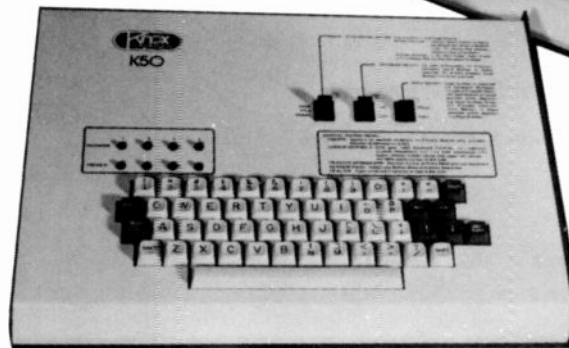

## Character Generator Specifications

**K128** General Description; Keyboard entry device for purpose of generating high resolution white alphanumeric in video form. Unit self-contained requiring only AC power and sync pulse train. Allows entry of information at any location on page. Audio I/O's included. Character Specifications: Display Format: 128 characters — 26 upper case, 26 lower case, 10 numerals, 26 typewriter symbols, 10 math symbols, 8 Greek letters, 11 foreign language letters, 9 special symbols, 1 flash, 1 space. Character resolution: 768 elements (32 horizontal x 24 vertical); Nominal character height: 32 scan lines, large, 16 scan lines, small; Page format: 24 characters/line; 8 lines/page. Input full interlace composite video-sync per EIA RS170, RS330, EIAJ or similar standards.

## Expansion Memory Unit

**KD-128** Fast random access page storage on flexible magnetic Floppy diskettes. Expands the K128 memory capacity to 400 pages, external. Roll or crawl continuously from page to page. OR, with the inclusion of the KAM128 automated control option, PROGRAM the 400 pages to do any combination of rolls/Crawls, full page displays, loop pages, pause the program, do character animation. A remote control unit is included with each system.

## Titling Unit

**K50** General Description: Keyboard entry device for purpose of generating white alphanumeric information in video form. Unit self-contained requiring only AC power and sync pulse train. Used as a video source or downstream keyer-inserter. Allows entry of information at any location or page. Independent program/preview channels. 4 full pages of memory. Character Specifications: Display format: 64 characters — 26 upper case, 10 numerals, 27 typewriter symbols, 1 space. Character resolution 7 x 9 dot matrix. Nominal character height 36 scan lines. Page format: 16 characters/line; 8 lines/page. Input: Full interlace composite video-sync per EIA RS170, RS330, EIAJ, or similar standards.

## Series K50/K60 Titlers

**K50** Character Generator with 4 pages of memory, independent edit channel, flash \$1095.00

**KS50** All features in K50 plus crystal controlled internal sync \$1225.00

**KX50** All features in KS50 plus title window, crawl, and automatically timed page sequencer \$1755.00

**Upgrade Kit** to convert K50 to KX50 (Factory installation) \$710.00

**K60** Character Generator with all K50 features but increases line length to 32 characters and number of lines to 16 \$1525.00

**KS60** All features in K60 plus crystal controlled internal sync \$1700.00

**KX60** All features in KS60 plus title window, crawl and automatically timed pages sequencer \$2085.00

## Series K128B Character Generators

**K128** High Resolution Character Generator with 4 pages of memory, italics, internal mixing audio I/O, extended character set, 3 pos. title window, double size \$3825.00

## Options: (To STD K128B)

<b>RC128TS</b>	3 speed roll/crawl	\$875.00
<b>PP128</b>	Independent Edit Channel	\$1115.00
<b>AC128</b>	Line-By-Line Auto Center	\$650.00
<b>MF246</b>	Multi-font very high resolution character set	\$1415.00

## Memories: (To STD K128B)

<b>IP008</b> Adds 4 pages for total of 8	\$545.00
<b>IP016</b> Adds 12 pages for total of 16	\$1425.00
<b>KD128</b> External 400 page diskette memory	\$5715.00
<b>KAM128</b> Automated control for KD128	\$1030.00
<b>KDR128</b> Remote control for use with KD128 and/or KAM128	\$1315.00
<b>KMD128</b> Floppy Diskettes	\$12.00/ea.

## Systems

<b>K128B/MOD8</b> K128B, RC128TS, AC128, PP128, IP008 with MF246	\$6160.00 \$7475.00
<b>K128B/MOD16</b> K128B, RC128TS, AC128, IP016, PP128, with MF246	\$8355.00
<b>KSD128</b> K128B, RC128TS, AC128, PP128, KD128 with MF246	\$11,195.00
with MF and KAM	\$12,365.00
<b>KSD246</b> K128B, RC128TS, AC128, PP128, MF246, KD128, KAM128, KDR128	\$13,830.00



L-W INTERNATIONAL

## TELECINE PROJECTOR

### Athena® 6000

#### 16mm Telecine Film Transport

The Athena 6000 is designed to meet most professional telecine requirements in NTSC, PAL and SECAM countries.

Many of the features and benefits listed below are exclusive to the Athena 6000:

- Slow motion/still frame
- Automatically phase-locks to NTSC, PAL or SECAM field rates
- Unlimited hold time in still frame mode
- Precision adjustable film gate assembly with 8.73mm x 10.16mm aperture
- Cost-effective modular design
- Multi-voltage/multi-frequency
- Cueing sensor (stops film)
- 50 to 5,000-foot film capacity (15.2 meters — 1520 meters)
- Remote control option
- Automatic lamp change-over
- Moderate price
- Two year parts and workmanship warranty

The Athena 6000 is totally modular, enclosed in a RTMA rack 19 inches (480mm) wide by 69 1/4 inches (1.7 meters) high. Each module contains all related electronics. These modules are sold separately for emergency back-up inventory. All connection are plug-in to further facilitate easy servicing.

Solid state technology reel tension sensors permit a wide range of reel sizes and film footage, from 50 feet (15.2 meters) to 5,000 feet (1520 meters). The result is gentle film handling. Upper and lower loop formers combined with an automatic stop feature (film break) further protect the film.

Dual projection lamps have automatic change-over feature. Illuminated pushbutton on control panel will enter flashing mode if change-over occurs. Dual exciter lamps are also equipped with automatic change-over.

#### Accessories/Options Include:

- A wide selection of lenses
- Remote control (4-wire multiplex technology). Multiple locations are possible
- Remote control with electronic frame counter

Price includes follow-up visit by Athena Field Service Engineer at no charge, within the 48 contiguous States and District of Columbia, U.S.A. Other locations require only per diem fee plus transportation.

**\$21,425.00**

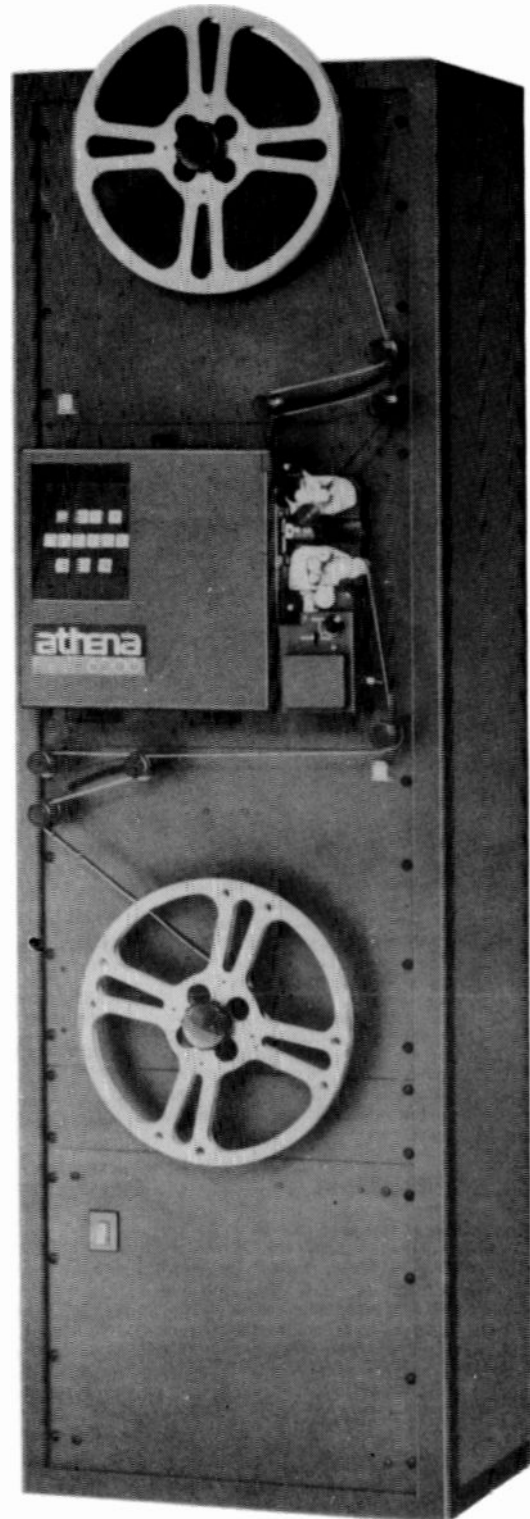



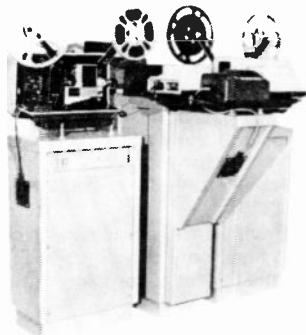

The Model 5300 Optical Multiplexer shown in combination with a Color Camera and a full 3-Input Projector Complement.

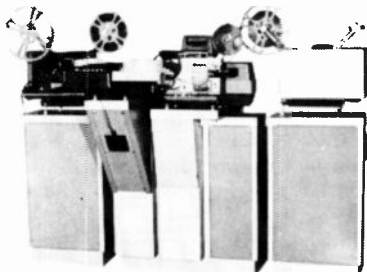

The Model 5400 Optical Multiplexer shown in combination with a Color Camera and a full 4-Input Projector Complement.

The **MODEL 5300 OPTICAL MULTIPLEXER** provides a method by which as many as three separate film images may be selectively projected for televising by a single camera. The use of first-surface mirrors and precision optics ensure excellent results in color TV applications. An integral field lens provides an intermediate image plane upon which both camera and projector lenses are focused. The field lens mounting is designed to permit insertion of a special screen for alignment purposes. The movable mirrors are shifted by individual electric gear motors through a unique torsion-bar/pitman coupling and produce an "instant" vertical wipe image transfer.

The basic 5300 Multiplexer consists of an optical transfer assembly, a main "bench" pedestal and a local control chassis. The entire optical area is protected against dust and ambient light by a plastic cover. The optical transfer assembly is supported for a 48" optical center by a bench pedestal constructed of heavy gauge die-formed steel. An enclosed entry box enables concealed connection and distribution of AC power to camera and projectors. The local control chassis permits push-button selection of projector inputs at the Multiplexer location and furnishes logic and power for remote control. A set of dry contacts provide for remote switching of audio or other purposes for each optical input.

A complete line of 16mm TV film projectors, slide projectors, interconnecting stands and shelves as well as other accessories and peripherals are available. Also available is engineering assistance in equipment selection and system design.

The **MODEL 5400 OPTICAL MULTIPLEXER** is similar to the Model 5300 described above except that it has the capability of multiplexing up to four separate film images. It has two field lenses to provide intermediate image planes upon which both the camera and the projector lenses are focused. The movable mirrors are shifted by a cam/aperture coupling but in both the 5300 and the 5400, automatic self-dousing is inherent in the vertical-wipe image transfer so that all unused input images are eliminated.

Two vacuum-formed plastic covers protect the entire optical area from dust and ambient light. The bench pedestals on both the 5300 and the 5400 have the lower portion of the pedestal surrounded by a recessed kick plate. Also, in both systems, the bench pedestal, stands and shelves feature removable panel sections for rack equipment mounting and access during installation. A large port in the rear section of each shelf and stand allows power and control cable entry and each has a rotatable cover which both closes the cable opening and furnishes strain relief for the cable.

**MULTIPLEXERS**

- 5300** Optical Multiplexer for three input sources (Small Image). Includes optical transfer assembly with field lens and cover, bench pedestal and local control. (Does not include camera or projector mounting shelves or stands). Note: Refer to lens extenders accessories section for special camera to lens interface components. . . . . \$1925.00
- 5340** Optical Multiplexer for three or four input sources (Large Image. Less field lens). Includes optical transfer assembly with cover, bench pedestal and local control. Three input unit may be field converted for fourth input source. (Does not include camera or projector mounting shelves or stands.)
  - For three input sources . . . . . \$3200.00
  - For four input sources . . . . . 3870.00
- 5040** Large Image Field Lens and mounting assembly for 5340 Optical Multiplexer. (Required for camera without integral field lens). . . . . \$1015.00
- 5400** Optical Multiplexer for four input sources (Small Image). Includes optical transfer assembly with field lens and cover, bench pedestal and local control. Requires 5041 ND mounting bracket for 410 light control. (Does not include camera or projector mounting shelves or stands) . . . . . \$2535.00
- 5330** Optical Multiplexer for three input sources (Large Image). Includes optical transfer assembly and cover, bench pedestal and local control. (Does not include field lens, camera or projector mounting shelves or stands). . . . . \$3375.00

**SHELVES AND STANDS**

(For 5300, 5340 and 5400 Multiplexers)

- 5104** Stand for cameras or projectors with optical center height between 8 1/4" and 12 1/4". Includes mounting adapter. (Specify camera or projector model when ordering) . . . . . \$390.00
- 5107** Shelf for small camera or projector. Includes mounting adapter. (Specify camera or projector model when ordering) . . . . . \$285.00

- 5108** Stand for camera or projector with height of less than 8 1/4" from mounting base to center of optics. Includes mounting adapter. (Specify camera or projector model when ordering) . . . . . \$290.00

**UNIPLEXERS**

- 5116** Optical Assembly with first surface mirror and field lens. Includes shelves and adapters for camera and 16mm film projector. (Specify camera and projector when ordering). Requires 50mm camera lens with 3/8" extender and 3" projection lens. (Lenses not included) . . . . . \$1100.00
- 5135** Optical Uniplexer Assembly same as above for one 35mm slide projector. (Less mirror) . . . . . \$985.00
- 5135m** Optical Uniplexer Assembly for monochrome camera and 35mm slide projector. (Less field lens and mirror) . . . . . \$495.00
- 5136** 105mm Camera taking lens and 1.57" lens barrel for use with 5135 Uniplexer. ("C" Mount) . . . . . \$225.00

**LENS EXTENDERS**

- 5015** 3/8" Lens Extender for 50mm lens to "C" mount camera adapter . . . . . \$20.00
- 5016** Lens Extender Kit (Cosmicar) . . . . . \$50.00

**MULTIPLEXER ACCESSORIES**

- 5021** Test Film Kit Loop. Includes RES, REG, FLESH TONE slides. RES 16mm film loop . . . . . \$200.00
- 5022** Eastman Kodak Gray Scale Slide . . . . . 300.00
- 5036** Neutral Density Filter Kit — 6 density filters supplied for mounting. For small image. (One Kit for each projector recommended). . . . . \$100.00
- 5037** Neutral Density Filter Kit — 6 density filters supplied for mounting. For large image. (One Kit for each projector recommended). . . . . \$225.00
- 5041** Mounting Bracket for 5050 light control for use with 5400 4-input optical multiplexer. . . . . \$40.00
- 5050** Automatic Light Control—maintains camera video at p/p . . . . . \$1915.00

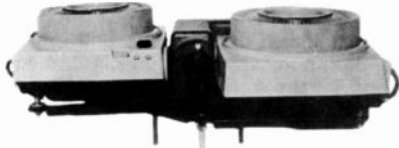

Front View 4220 — Local Control

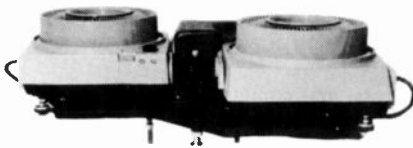

Front View 4210

The **MODEL 4220 DISSOLVE DUAL DRUM SLIDE PROJECTOR** provides a large slide capacity projector with time-controlled dissolve transitions. The 4220 Dual Projector offers the alternate sequencing of up to 160 glass, metal, plastic or paper-mounted 2" x 2" slides from a dual configuration of Eastman Ektagraphic projectors. Both projectors share a single, high-quality projection lens. This, together with quartz halogen light sources, make the projector ideal for color television applications.

The image transfer between successive slide exposures is accomplished by means of an optical beam splitter which produces a smooth time-controlled dissolve. This fade from one slide to the other can be varied, by means of a panel control, from less than half of a second up to a full 15 seconds. On the same control panel, push buttons allow a choice of the dissolve mode or a minimum-time "cut" transfer. There are also push buttons to control the functions of "off", "Ready", "Advance", "Reverse", and "Alternate" plus buttons to deactivate one drum while maintaining use of the other thus allowing independent use of either projector.

Accessories available include the Model 2525 Remote Control with a full complement of control functions, and the Model 2526 Tone Generator/Decoder which not only can be used for audible change-slide cues in the normal manner but also offers the capability for a completely automated slide show.

The **4210 DUAL DRUM SLIDE PROJECTOR** provides a large slide capacity projector with broadcast-quality lap-dissolve transitions. The 4210 projector offers the alternate sequencing of up to 160 glass, metal, plastic or paper-mounted 2" x 2" slides from the dual configuration of Eastman Ektagraphic projectors. Image transfer between successive slides is accomplished by means of movable first surface mirrors.

Accessories available include the Model 2515 Remote Control that provides "Off", "Ready", "Show", "Advance", "Reverse" and "Alternate". The 2513 Remote Reconcile provides individual control of each drum.

**PROJECTORS**

- 4110 Eastman Single Drum Slide Projector.** Holds 80, 35mm slides. Includes modified 7" lens and adjustable mount. (Requires 5107 Shelf or 5108 Stand). (Use 2508 Remote and 3504 Adapter for remote control) ..... \$ 495.00
- 4210 Dual Drum Slide Projector.** Holds 160, 35mm Slides. Includes lens and adjustable mount.
  - With 7" lens for Small Image System ..... \$2170.00
  - With 7 1/2" lens for Large Image System ..... \$2655.00
  - With 9" lens ..... \$2655.00
 (Requires 5107 Shelf or 5108 Stand). (Uses 2515 for remote control). (Uses 2513 for remote reconcile).
- 4220 Dual Drum Dissolve Slide Projector.** Hold 160, 35mm Slides. Includes lens and adjustable mount.
  - With 7" lens for Small Image System ..... \$3785.00
  - With 7 1/2" lens for Large Image System ..... \$4265.00
  - With 9" lens ..... \$4265.00
 (Requires 5107 Shelf or 5108 Stand). (Uses 2525 for remote control). (Uses 2526 for program tone generator).
- TV-M100A Eastman Super 8mm TV Film Projector.** Includes 40mm lens. (Requires 5104 Stand). (Uses 2510 remote and 3509 adaptor for remote control) ..... \$3340.00
- TV-12M6 Eastman 16mm TV Film Projector,** Includes 3" lens. (Requires 5104 Stand). (Uses 2510 remote and 3509 adaptor for remote control) ..... \$3945.00
- 103ONLTI Singer 16mm TV Film Projector.** Includes 3" lens and Optical Playback. (Requires 5108 Stand). (Uses 2510 remote and 3501 adaptor for remote control). ..... \$2080.00
- 223OLTI Singer 16mm TV Instaload Film Projector.** Includes 3" lens, fast forward and reverse mode and Optical Playback. (Requires 5108 Stand). (Uses 2510 remote and 3503 adaptor for remote control) ..... \$2300.00
- NT-2LTI Eiki Autoload 16mm TV Film Projector.** Includes 3" lens, Optical and Magnetic Playback, and Remote Adapter. (Requires 5108 Stand). Uses 2523 remote control. .... \$2450.00
- NT-3LTI Eiki Autoload 16mm TV Film Projector.** Includes 3" lens, Optical and Magnetic Playback, and Remote Adapter. (Requires 5108 Stand). Uses 2523 remote control ..... \$2950.00

**REMOTE CONTROL**

- (All modules use 1/3 of rack width unless otherwise indicated)
- 1506 Rack Frame** — accepts up to three remote control modules. Blank filler panels provided, if necessary. Frame is 19" w x 3 1/2" h x 3" d ..... \$ 60.00
- 2508 Control, Remote** — for Model 4110 Single Drum Slide Projector. "Off", "Ready", "Show", "Forward", and "Reverse" slide change ..... \$ 145.00

- 2509 Control, Remote** — for two 16mm TV Film Projectors. (Dual configuration of 2510 below) ..... \$ 175.00
- 2510 Control, Remote** — for slide and film projectors. Controls "Off", "Ready", and "Show" modes ..... \$ 115.00
- 2513 Control, Remote Reconcile** — (optional) for Model 4210 Dual Drum Slide Projector. Adds individual "Forward" and "Reverse" control of Drum A and Drum B ..... \$ 115.00
- 2515 Control, Remote** — for Model 4210 Dual Drum Slide Projector. "Off", "Ready", "Show", "Forward", "Reverse", and "Alternate" ..... \$ 175.00
- 2516 Control, Remote** — for 5400 Multiplexer. Controls input sources 1, 2, 3 and 4. Uses 3/8 of rack frame. (Not required with LTI projector remote control system) ..... \$ 115.00
- 2517 Control, Remote** — for 5300 Multiplexer. Controls input sources 1, 2 and 3. (Not required with LTI projector remote control system) ..... \$ 115.00
- 2519 Control, Remote** — for Splinder and Sauppe' S-32B slide projector. Controls "Off", "Ready", "Show", "Alternate", "Auto Change", "Advance Left", "Advance Right", "Hold Left", and "Hold Right" uses 3/8 of rack frame ..... \$ 275.00
- 2523 Control, Remote** — for Model 561A and 562A Bell and Howell projector with LTI mod. "Off", "Ready", and "Show", "Forward", and "Reverse" ..... \$ 145.00
- 2525 Control, Remote** — for Model 4220 Dual Drum Dissolve Slide Projector. Includes all local control functions. Uses 3/8 of rack frame ..... \$ 495.00
- 2526 Tone Generator** — for Model 4220/2525 Dissolve Slide Projection System ..... \$ 335.00
- 2528 Control, Remote** — for Model 5050 ND Wheel ..... \$75.00
- 2533 24 Volt Power Supply** — for Uniplexer remote control ... \$185.00

**ADAPTERS FOR REMOTE CONTROL**

- 3501 Adapter, Projector Remote** — for 930 LTI TV Film Projector ..... \$ 70.00
- 3503 Adapter, Projector Remote** — for 1130 LTI TV Film Projector ..... \$ 70.00
- 3504 Adapter, Projector Remote** — for 4110 Slide Projector. \$ 105.00
- 3507 Adapter, Projector Remote** — for 322 Spindler and Sauppe' Slide Projector. .... \$ 105.00
- 3509 Adaptor, Projector Remote** — for TV-M100A and TV12M6 Kodak TV Film Projector. .... \$105.00
- 3510 Universal Adapter, Projector Remote** — with A.C. power cord for all projectors without remote provisions. Includes local controls "Off" and "Ready" ..... \$ 145.00

# LAIRD TELEMEDIA INC.<sup>®</sup> CHARACTER GENERATOR

## 3600A Chassis



3610A Keyboard

The Model 3600A Television Character Generator includes standard features such as 10 line by 25 character format with adjustable character width, 1k (four page) solid state memory, preview and program outputs, keyboard controlled program character on/off edging. Other standard keyboard control functions permit selective Underline, Overline, Crawl, Roll, Box, Flash and word length selection of either black or white characters. As many as three additional solid state memories, each of four, eight, twelve or sixteen page capacity, may be either included or added later, giving a total of sixty-four pages of solid state memory.

## Character Generator

**3600A Character Generator** — 10 lines of 25 characters with one preview and one program output 9 x 14 font with large and small characters, 1000 character memory with 4 pages of roll, crawl, and pop-up Internal — External video selector switch, horizontal edging and auto centering all are provided as standard features Must be driven by composite video Requires 3610A or 3615A Keyboard **\$4,050.00**

**3610A Keyboard** for 3600A Character Generator with character on off black white, large/small and fast roll slow switch, and 16-key control Includes 15' of interconnect cable **\$728.00**

**3615A Keyboard** Memory for 3600A Character Generator with character on/off, black/white, large small, and fast roll slow roll switch, and 22-key control Provides unlimited data storage on built-in heavy duty industrial audio cassette unit Includes 15' of interconnect cable **\$1,848.00**

## 3600A Options

**3620A Additional color output channel for 3600A** Provides one additional video input output channel programmed from the first program channel Requires a 3634B memory board **\$850.00**

**3622A Dual floppy disk memory** — Provides copying capability of memory up to 2000 pages May access file for random page and operate in page or file mode Contains separate keyboard control (Formerly 3618A) **\$5,000.00**

**3624A Single floppy disk memory** allows for copying of stored memory up to 1000 characters May be operated in page or file mode and accessed page or file Contains separate keyboard control (Formerly 3617A) **\$4,000.00**

**3630A Fixed Title** — Provides 25 Character title line (Total of 16 fixed title lines can be used per generator Indicate line location and characters when ordering) **\$50.00**

**3632A RS 232 Interface to a computer** Includes external switch to utilize 3610A or 3615A keyboard or computer (Consult factory for control codes) **\$300.00**

**3634B Solid State Memory** — PC Board for 1000 characters of roll crawl 10 LN, 2 LN pop-up (Total of 4 memories can be used per generator) **\$605.00**

**3634C Solid State Memory** — Add-on for 1000 characters of roll crawl 10 LN, 2 LN pop-up (Requires 3634B Memory Total of 3 add-on memories can be used per 3634B memory) **\$330.00**

**3640A Temperature Sensor** — includes PC Board interface electronics, sensor and 100 ft. of interconnect cable Provides fixed title and temperature display \* **\$455.00**

**3641A Time Generator** — provides fixed title and time display \* **\$295.00**

**3642A Date Generator (Requires 3641A)** — provides fixed title and date display \* **\$350.00**

**3643A Up Down Counter** — provides fixed title and up/down counting time clock display \* **\$460.00**

**3644A BCD input for 3600A** Consult factory for special engineering requirements **\$695.00**

**3650A Color background, NTSC color sync generator**, including single pulse drive outputs and adjustable pulse delay for color phasing with external video source Controlled format display of any combination of red, green, or blue background Provides H, V, SY, BL, BG, and SC (Less genlock) **\$1,265.00**

**3652A Color background, pulse interface** Provides interface with drive pulse from external sync generator Controlled format display of any combination of red, green, or blue backgrounds Requires SY, BL and SC **\$977.00**

**Service Manual** **\$38.00**

\*Only 2 data source options can be used per chassis

## 1200A Character Generator

**1200 Character Generator** — Self contained with standard 8 pages of 2048 total characters 9 x 14 upper case font Has word or line flashing and black or white switch, automatic or manual page display sequencing **\$1,995.00**

## 1200 Options

**1230 Fixed Title Memory** — one memory with up to 8 lines can be used Indicate line locations and characters when ordering **\$295.00**

**1232 Solid State Memory** — will add 2048 characters Add 10% to price for retrofit **\$595.00**

**1234 Plug in Format Cards** Each of these offers an extra format Specify number of lines and number of characters per line **\$125.00**

## Model 1021 Electronic "Q" Board

The 1021 Q Board adds that professional touch to your video tape productions. By a method similar to that involving a "clap" board used in movie making important production information may be televised and recorded on the leader of any commercial or program tape. Also, both an aural and visual countdown, recorded just prior to program information, will allow accurate cueing in playback. Emission of a countdown beep tone from the built-in speaker serves to alert the studio crew and talent during taping sessions.



Model 1021 Electronic "Q" Board

**1021 Electronic "Q" Board** — with built-in speaker may be remotely controlled **\$395.00**

**1040 Video "Q" Board** — Visual and audio count down with audio cue tone Composite sync and video compatible with local and remote control Standard 10 second cue with last 2 seconds as dead time Adjustable character size **\$595.00**

**1060 Video Pointer** — black or white arrow, two size indicator Includes two size outline highlight blank out or block custom logo Arrow may be oriented in 8 different positions with rotary switch **\$995.00**

# Lee-Ray Industries, INC.

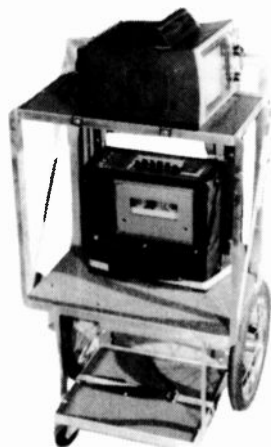

5100F

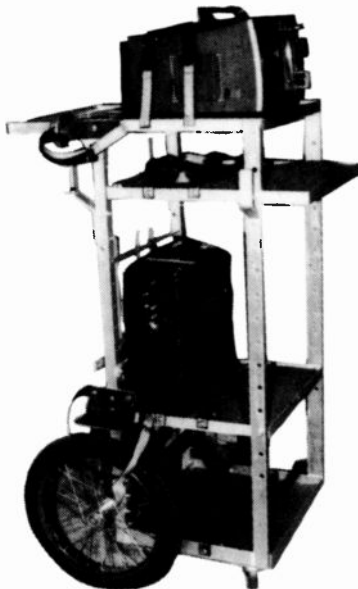

3500



4000

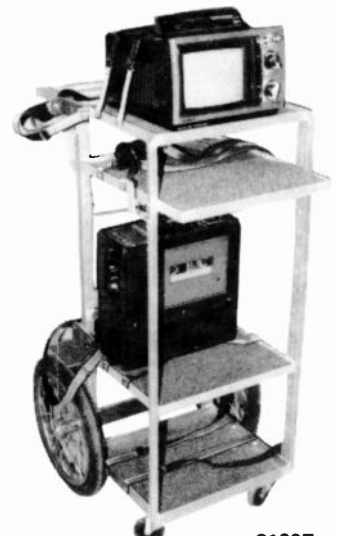

3100F

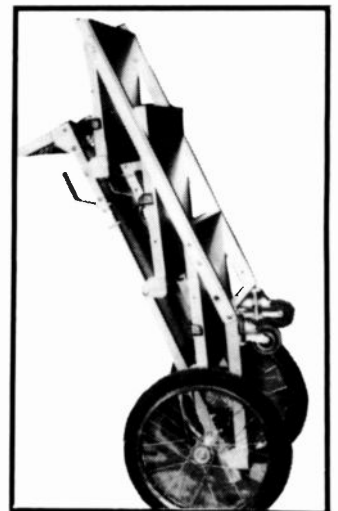

## VIDEO EQUIPMENT CARRIERS

### Our New and Latest Lightweight Video Equipment Carrier

**3100F — Features of Carrier:** • Lightweight — anodized aluminum • Only 24 pounds • Foam padded shelves • Adjustable straps — each shelf • All shelves fold — easy to put in car or truck • Drilled plate in handle to accept camera elevator • Cable holders • 16" air cushion tires — 23" wheelcase • Easy up and down stairs • 3" casters on front • 1 year limited structural warranty • Shipped UPS • F.O.B. Mesa, Az. \$535.00

**Rigid — Sturdy — Put all your equipment on wheels.**

**Options:** • Waterproof dust cover • Heavy-duty AC Strip — switch, light-circuit breaker and bracket • Tripod or light holding attachment • Gimbeled battery box

### Video Equipment and Instrument Carrier

**3500 — Features of Carrier:** • Main Feature — Lightweight and Large Wheels • All anodized aluminum • Welded unit • Bolt-in padded shelves • Space shelves to fit your equipment • Safety straps each shelf • Easy up and down stairs • 16" spoke wheels — ball bearings air tires, on 21" wheelbase • Locking casters on front • Casters — handle (optional) • Drilled plate in handle to accept camera elevator — 2 1/4" hole • 1 year limited structural warranty • F.O.B. Mesa, Az. • Total weight w/4 shelves — 26 lbs. \$519.00

**Options:** • Additional shelves • Waterproof dust cover

### Add-A-Shelf

**4000 — Features of Carrier:** • Main Feature — Lightweight • All anodized aluminum • Welded unit • Bolt-in padded shelves • Space shelves to fit your equipment • Safety straps each shelf • Easy up and down stairs • 16" spoke wheels — ball bearings, air tires, on 21" wheelbase • Locking casters on front • Casters — handle (optional) • Drilled plate in handle to accept camera elevator — 2 1/4" hole • 1 year limited structural warranty • F.O.B. Mesa, Az. • Total weight w/4 shelves — 26 lbs. \$565.00

**This carrier designed and built to carry the Ampex VPR-20. Most other 1" recorders**

**5100F — Features of Model:** • 1" Recorders • Yet lightweight — 25 lbs. • All anodized aluminum • Foam padded shelves • All straps as necessary for equipment • Easy up and down stairs • On 16" spoke wheels, ball-bearings, air tires, on 21" wheelbase • Locking caster on front • Drilled plate in handle to accept camera elevator — 2 1/4" hole • Cable holders • Folds to put in vehicle • 1 year limited structural warranty • F.O.B. Mesa, Az. \$688.00

**Put all your heavy equipment on wheels.**

**Options:** • Waterproof dust cover • AC strip — 6 plug, switch, light, circuit breaker and mounting bracket • Gimbeled battery box

### PAN AND TILT HEADS

(100-400 LB. CAPACITY)

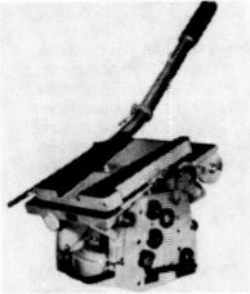

Mark IIIA Cam Head supplied with Mitchell Base, Full-sized Pan Bar and Clamp, 3/8" Bolt Fixing to Camera

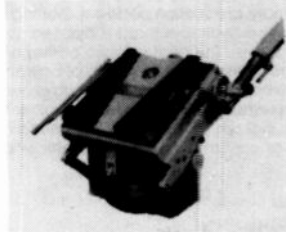

Mark VII L.F. Cam Head shown with optional 3084/14 Female Wedge Adaptor

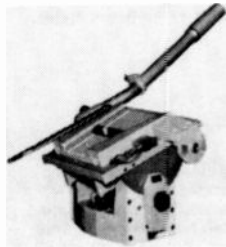

Mark V Cam Head supplied with Mitchell Base, Full-sized Pan Bar and Clamp, 3/8" Bolt Fixing to Camera

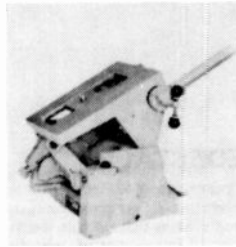

Petrel Mark II L.F. Pan and Tilt Head

### PAN AND TILT HEADS

(25-50 LB. CAPACITY)



Post Pan and Tilt Head supplied with an appropriate base (Mitchell or Pro Jr.) and one full size Pan Bar



Dunlin L.F. Pan and Tilt Head Supplied with appropriate base and one full size Pan Bar

### ENG PAN AND TILT HEADS

(SHOWN ON VINTEN 3201 ENG TRIPOD)

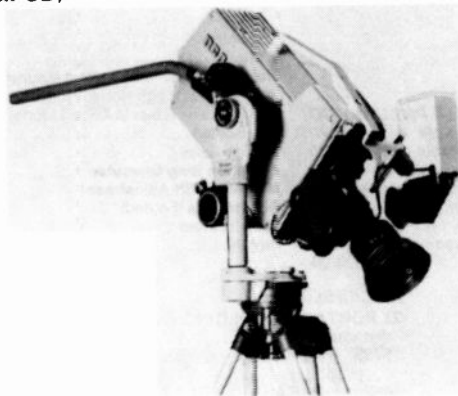
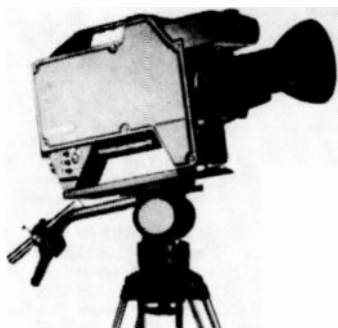

#### 3717 Mark IIIA Cam Head

##### SPECIFICATIONS

Capacity	400 lbs.
Weight	44 lbs.
Cam Sizes	5"-11"
Tilt Range	+ / -50°
Width, Length, Height	12", 14", 7"
Construction	Stainless Steel, Aluminum and Magnesium Alloy Castings
Finish	Grey Textured Stove Enamel

with Anti-Corrosion Plating on all Bright Metal

#### 3084 Mark VII L.F. Cam Head

##### SPECIFICATIONS

Capacity	200 lbs.
Weight	35 lbs.
Cam Sizes	4 1/2" - 11"
Tilt Range	+ / -60°
Width, Length, Height	11", 11.5", 9.5"
Construction	Stainless Steel, Aluminum and Magnesium Alloy Castings

Finish Grey Textured Stove Enamel with Anti-Corrosion Plating on all Bright Metal

#### 3716 Mark V Cam Head

##### SPECIFICATIONS

Capacity	180 lbs.
Weight	24 lbs.
Cam Sizes	3"-8"
Tilt Range	+ / -60°
Width, Length, Height	15", 9", 7"
Construction	Stainless Steel, Aluminum and Magnesium Alloy Castings

Finish Grey Textured Stove Enamel with Anti-Corrosion Plating on all Bright Metal

#### 3076 Mark II L.F. Pan and Tilt Head

##### SPECIFICATIONS

Capacity	100 lbs.
Weight	15 lbs.
Center of Gravity Compensation	2"-7 1/2"
Tilt Range	+ / -40°
Width, Length, Height	6 1/2", 9", 7"
Construction	Stainless Steel, Aluminum Alloy Castings

Finish Grey Textured Stove Enamel with Anti-Corrosion Plating on all Bright Metal

#### 3078 Post Pan and Tilt Heads

##### SPECIFICATIONS

Capacity	50 lbs.
Weight	20 lbs.
Tilt Angle	360°
Pan Angle	360°
Tilt Axis Height Adjustment (measured from head mounting face)	Max. 13 1/2" - Min. 10 1/2"
"L" Bracket Platform Adjustment (Measured from head mounting face)	Max. 10" - Min. 6 1/2"

Maximum Camera Width to "L" Bracket . . . . . 6 1/2"

#### 3051 L.F. Pan and Tilt Head

##### SPECIFICATIONS

Capacity	50 lbs.
Weight	11 lbs.
Center of Gravity Compensation	Variable from 6 1/2" at 50 lbs.
Tilt Range	+ / -50°
Width, Length, Height	8 1/2", 6 1/2", 7"
Construction	Stainless Steel, Aluminum Alloy Castings

Finish Black Stove Enamel with Anti-Corrosion Plating on all Bright Metal

#### 3199 ENG Pan and Tilt Head

##### SPECIFICATIONS

Capacity	30 lbs. at 7" C. of G.
Weight	7 1/2 lbs.
Tilt Angle	+ / -90°
Pan Range	360°

#### 3089 Cygnet L.F. Mini Post

##### SPECIFICATIONS

Capacity	25 lbs.
Weight	10 lbs.
Tilt Angle	360°
Pan Angle	360°

Cygnet Pan and Tilt Head supplied with Pro, Jr. Mitchell, Claw Ball, or Sachtler Ball, and one full size Pan Bar.



## 3702 FULMAR EXTENDED RANGE PNEUMATIC PEDESTAL

It is doubtful whether this pedestal could ever become obsolete and in a short span of just a few years the FULMAR has become regarded by all types of users as the ultimate production pedestal. Starting from the tremendously strong base, which contains a welded steel annular low pressure tank, the available thrust is applied to the piston of a precision three stage ram assembly which supports the camera mounting platform. This platform also carries a single lifting/steering ring for one handed operation. Special magnesium alloy telescoping tubes, each with four pairs of ballraces, two pairs of which are always adjustable, ensure that absolute rigidity of the pedestal column is maintained. The unsurpassed range of elevation and depression (21°-59°) allows shots to be obtained of the studio action without recourse to risers or other types of platforms. In addition, the fluid motion of the pedestal allows a continuity of program that will satisfy the most demanding director. All parts are machined meticulously and the built-in adjustments ensure long life at optimum mechanical efficiency.

**3702 FULMAR EXTENDED RANGE PNEUMATIC PEDESTAL** supplied with single combined lifting steering ring, pedal-operated change over from crab to tricycle steering, adjustable cable guards, dual wheels, 15 lbs. total trim weights, pressure gauge and wheel cutouts for visual inspection. . . . . \$17,300.00

Capacity . . . . .	350 lbs. at 200 P.S.I. (typically, 250lbs require 150 P.S.I.)
Weight . . . . .	330 lbs.
Height Range . . . . .	21°-58½° (to Cam Head Mounting Face)
Width at Base . . . . .	Min. 34" - Max. 39"
Construction . . . . .	Magnesium Alloy Castings, Steel Reservoir
Finish . . . . .	Grey Textured Stove Enamel with Anti-Corrosion Plating on all Bright Metal

## 3741 TERN PNEUMATIC PEDESTAL

When operating modes do not warrant the purchase of a full production pedestal such as the 702 above, the 741 Tern will provide much more than just adequate performance. Designed as a direct replacement, in terms of operating range, to the original lead counterbalanced pedestals which were standard in the industry at one time, the 741 is only half the weight. This ensures that much less effort is required to move the pedestal over the studio floor which discourages "flat spots". A large annular low pressure tank supports a single stage ram assembly providing a long 21" stroke. The supporting column is carried on three pairs of ballraces, one pair of which is eccentrically mounted. All moving parts in this pedestal, as in the case of the 702, can be adjusted for eventual wear to maintain optimum performance. This engineering approach is standard with all Vinten products. The 741 is supplied complete with trim weights for minor load variation and with gimballed wheels and adjustable cable guards as standard.

**3741 TERN PNEUMATIC PEDESTAL** supplied with single lifting steering ring, pedal-operated change over from crab to tricycle steering, adjustable cable guards, 7" dual duothane wheels, 20 lbs. total trim weights. . . . . \$8300.00

Capacity . . . . .	290 lbs. at 230 P.S.I. (typically, 150 lbs. at 125 P.S.I.)
Weight . . . . .	250 lbs.
Height Range . . . . .	33°-54° (to Cam Head Mounting Face)
Width at Base . . . . .	Min-29½" - Max-36"
Construction . . . . .	Aluminum Alloy Castings, Steel Reservoir
Finish . . . . .	Grey Textured Stove Enamel with Anti-Corrosion Plating on all Bright Metal

### ACCESSORIES

3806-1155 NITROGEN REGULAR with Hose and Adapter to pedestal. Preferred low cost method to charge pedestal where compressed Nitrogen is available, eliminates contamination of steel reservoir and allows fast charge-up time . . . . . \$255.00

C100 AIR COMPRESSOR, A/C powered and mounted on wheels. Delivers up to maximum 200 P.S.I. Used where storage of Nitrogen Cylinder presents problems. Weight 110 lbs. . . . . \$695.00

## 3056/3C PortaPed

The recent development of lightweight color cameras to broadcast standards has permitted the production of more sophisticated support equipment. Whereas previously, sheer weight and size ruled out the possibility of combining several functions in one unit, the latest cameras, even when loaded up, can be handled in a variety of new ways. The PortaPed is a combination self-leveling tripod with a built-in pedestal type column that can charge itself up for counterbalancing purposes just by exercising the column. This is accomplished using only the available atmosphere and no external charging apparatus is required. In addition, unlike other units, there are no fluids to leak from the PortaPed. All functions are achieved by traditional mechanical means. The PortaPed is lightweight, easy to set up and folds away neatly. It is also the basis of a number of other interesting Vinten Portable Mountings shown.

**3056 PortaPed PORTABLE PNEUMATIC PEDESTAL** supplied complete with Pro Jr. Top, "THREE WAY" Adjustable legs for both height and direction, lifting ring, carrying handle, column lock and adjustable drag controls. Options include simple Type 71 PortaSkid castoring Dolly or Type 64 TriTrack Crabbing Base. See accessories . . . . . \$4600.00

Capacity . . . . .	120 lbs.
Weight . . . . .	33 lbs.
Height Range (To Pan Head Mounting Face)	
Low Level (Legs Horizontal)	27°-45°
High Level (Legs in Tripod Mode)	37°-55°
Leg Radius . . . . .	Low Level-20"
High Level . . . . .	16"
Elevation Ring Diameter . . . . .	11"
Maximum Tilt Adjustment . . . . .	40°
Dimensions (Folded) . . . . .	27", 11", 11"
Construction . . . . .	Aluminum Alloy, Steel Tank
Finish . . . . .	Black Anodized Grey Textured Stove Enamel with Anti-Corrosion Plating on all Bright Metal

### ACCESSORIES

71 PORTASKID FOLDING DOLLY with 5" diameter wheels . . . . . \$850.00  
15735 PORTAPED CARRYING CASE . . . . . \$300.00  
16520 PORTASKID CARRYING CASE . . . . . \$135.00

3064 TRITRACK CRABBING BASE for PortaPed (described elsewhere) . . . . . \$4800.00  
3067 DOLPHIN CRANE ARM (described elsewhere) . . . . . \$6875.00  
3072 TRIMOUNT COLUMN to mount Dolphin into TriTrack . . . . . \$385.00  
3073 PLATFORM AND SEAT ASSEMBLY for TriTrack . . . . . \$850.00

Prices and specifications subject to change without notice

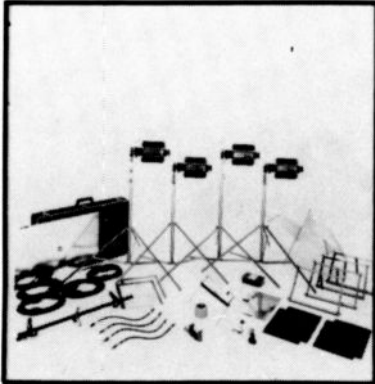

T1-94M

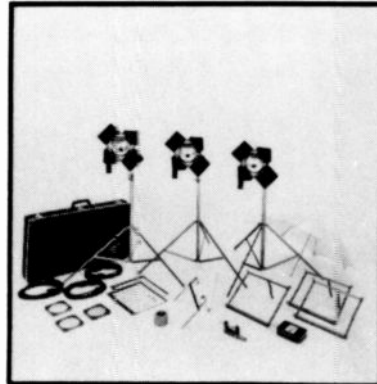

01-93

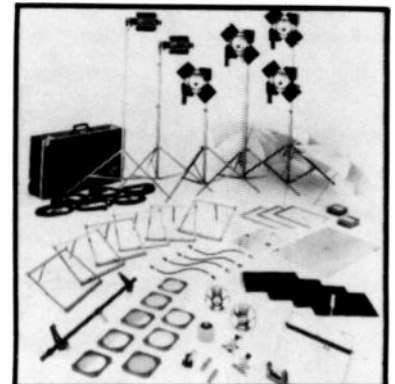

T0-96

## TOTA/OMNI KITS

<b>T1-93M</b>	<b>carry-on kit</b>	19 lbs.	8.62 kg.	645.00
	3 tota-lights, 16' cables (less lamps); 3 tota-frames; assorted gels; 3 tota-flags; 1 tota-flector; 4 flexishafts; 1 tota-mount; 1 tota-clamp; 1 small space clamp; 1 12 yard gaffer tape; 1 tota-lampak; 1 tota-case.			
<b>T1-90</b>	<b>tube kit</b>	14 lbs.	6.35 kg.	485.00
	2 tota-lights, 16' cables (less lamps); 1 tota-brella; 1 tota-frame; 1 assorted gels; 2 omni-stands; 1 tota lampak; 1 tube case.			
<b>T1-92M</b>	<b>trans-kit</b>	29 lbs.	13.15 kg.	725.00
	3 tota-lights, 16' cables (less lamps); 3 tota-brellas; 3 omni-stands; 1 tota-lampak; 1 tota/omni molded case			
<b>T1-94M</b>	<b>t4 kit</b>	40 lbs.	18.14 kg.	1250.00
	4 tota-lights, 16' cables (less lamps); 1 tota-brella; 4 tota-frames; 2 assorted gels; 1 lightflector/tilter; 4 tota-flags; 1 tota-flector; 4 flexi shafts; 1 tota-tatch; 4 omni-stands; 1 tota-mount; 1 tota-clamp; 1 large space clamp; 1 12 yard gaffer tape; 1 tota-lampak; 2 tota-packets; 1 tota/omni case.			
<b>01-92</b>	<b>action kit</b>	28 lbs.	12.70 kg.	875.00
	3 omni-lights, 16' cables, # 1 reflectors (less lamps); 3 omni-barndoors; 3 omni-stands; 1 omni-lampak; 1 tota/omni case.			
<b>01-93</b>	<b>omni 3 kit</b>	32 lbs.	14.51 kg.	1065.00
	3 omni-lights, 16' cables, # 1 reflectors (less lamps); 3 omni-barndoors; 2 full scrims; 1 half scrim; 1 tota-brella; 3 tota-frames; 2 assorted gels; 3 omni-stands; 1 tota-mount; 1 tota-clamp; 1 12 yard gaffer tape; 1 omni-lampak; 1 tota/omni case.			
<b>01-94M</b>	<b>spatial kit</b>	42 lbs.	19.05 kg.	1380.00
	4 omni-lights, 16' cables, # 1 reflectors, (less lamps); 4 omni-barndoors; 1 # 3 superspot reflector; 1 diffused glass; 2 full scrims; 1 half scrim; 1 graduated scrim; 4 tota-frames; 2 assorted gels; 4 omni-stands; 1 large space clamp; 1 tota-clamp; 1 omni-lampak; 1 omni case.			
<b>T0-97</b>	<b>basically 3 kit</b>	28 lbs.	12.70 kg	775.00
	2 tota-lights, 16' cables (less lamps); 1 omni-light 16' cable, # 1 reflector (less lamp); 1 omni-barndoor; 1 full scrim; 1 tota-brella; 1 tota-frame; 1 assorted gels; 3 omni-stands; 1 tota/omni lampak; 1 tota/omni molded case			
<b>T0-95</b>	<b>ambi kit</b>	39 lbs.	17.69 kg.	1350.00
	2 tota-lights, 16' cables (less lamps); 2 omni-lights, 16' cables, # 1 reflectors (less lamps); 2 omni-barndoors; 2 full scrims; 1 half scrim; 2 tota-brellas; 4 tota-frames; 2 assorted gels; 2 tota-flags; 1 tota-flector; 4 flexi-shafts; 1 tota-tatch; 4 omni-stands; 1 tota-mount; 2 tota-clamps; 1 12 yard gaffer tape; 2 tota/omni lampaks; 1 tota packet; 1 tota/omni case.			
<b>T0-98</b>	<b>elemental kit</b>	31 lbs.	14.06 kg.	865.00
	1 tota-light, 16' cable (less lamp); 2 omni-lights, 16' cables, # 1 reflectors (less lamps); 2 omni-barndoors; 1 full scrim; 1 tota-brella; 2 tota-frames; 1 assorted gels; 3 omni-stands; 1 tota/omni lampak; 1 tota/omni molded case			
<b>T0-96</b>	<b>solo kit</b>	58 lbs.	26.30 kg.	2100.00
	2 tota-lights, 16' cables (less lamps); 4 omni-lights, 16' cables, # 1 reflectors (less lamps); 2 # 3 superspot reflectors; 4 omni-barndoors; 2 diffused glass; 2 full scrims; 2 half scrims; 1 graduated scrim; 1 cookaloris; 3 tota-brellas; 6 tota-frames; 3 assorted gels; 1 lightflector/tilter; 4 tota-flags; 1 tota-flector; 4 flexi shafts; 5 omni-stands; 1 tota-mount; 2 tota-clamps; 1 large space clamp; 2 tota-tatches; 1 12 yard gaffer tape; 2 screw in studs; 2 tota/omni lampaks; 1 tota-packet; 1 omni case.			

## TOTA/OMNI SYSTEMS

T1-10	tota-light	2 <sup>1</sup> / <sub>2</sub> lbs.	1.02 kg.	105.00
01-10	omni-light	2 <sup>3</sup> / <sub>4</sub> lbs.	1.19 kg.	125.00
01-13	omni-light 30v.	2 <sup>1</sup> / <sub>2</sub> lbs.	1.02 kg.	135.00
01-15	# 1 reflector	2 oz.	57 g.	12.00
01-16	# 2 reflector	2 oz.	57 g.	12.00
01-17	# 3 reflector	2 oz.	57 g.	12.00
01-18	# 4 reflector	2 oz.	57 g.	12.00
T1-20	tota-frame	6 oz.	.17 kg.	24.50
GELS: PACKAGE OF 5, 10x12" (25x30cm)				
T1-69	blue frost gels	2 oz.	57 g.	10.50
T1-70	day blue gels	2 oz.	57 g.	10.50
T1-71	n.d. 3 gels	2 oz.	57 g.	10.50
T1-72	frost gels	2 oz.	57 g.	10.50
T1-78	assorted gels	2 oz.	57 g.	10.50
T1-25	tota-brella	8 oz.	.23 kg.	30.00
T1-34	tota-tatch	2 oz.	57 g.	11.00
T1-50	flexishaft 16" (2)	4 oz.	.11 kg.	16.50
T1-52	tota-flag	4 oz.	.11 kg.	15.00
T1-54	tota-flector	6 oz.	.17 kg.	19.50
LFT	lightflector/tilter	1 <sup>3</sup> / <sub>4</sub> lbs.	.79 kg.	75.00
01-20	complete barndoor	8 oz.	.23 kg.	49.00
01-21	barndoor frame	2 oz.	57 g.	21.50
01-22	rectangular leaf	2 oz.	57 g.	9.50
01-23	triangular leaf	1 oz.	28 g.	9.00
01-50	diffused glass	3 oz.	85 g.	23.50
01-51	dichroic filter	3 oz.	85 g.	75.00
01-52	clear glass	3 oz.	85 g.	22.50
01-53	snoot	4 oz.	.11 kg.	24.00
01-54	full scrim	2 oz.	57 g.	12.00
01-55	half scrim	2 oz.	57 g.	12.00
01-56	graduated scrim	2 oz.	57 g.	14.50
01-57	cookaloris	2 oz.	57 g.	12.00
01-33	omni-stand	2 <sup>1</sup> / <sub>2</sub> lbs.	1.30 kg.	79.00
KPH	half pole	1 lb.	.45 kg.	39.00
SC-10	large space clamp	1 <sup>1</sup> / <sub>2</sub> lbs.	.68 kg.	48.50
SC-20	small space clamp	1 <sup>1</sup> / <sub>4</sub> lbs.	.57 kg.	42.50
T1-30	tota-clamp	4 oz.	.11 kg.	18.50
T1-32	tota-mount	10 oz.	.28 kg.	25.00
GT-12	gaffer tape 12 yards	8 oz.	.23 kg.	8.50
GT-30	gaffer tape 30 yards	1 <sup>1</sup> / <sub>4</sub> lbs.	.57 kg.	15.50
LSS	screw-in stud (2)	3 oz.	85 g.	9.00
T1-35	tota-daptor	4 oz.	.11 kg.	15.00
T1-36	tota-tilter	4 oz.	.11 kg.	20.00
T1-80	16' tota/omni cable	13 oz.	.37 kg.	22.50
01-81	5' omni 30v cable	7 oz.	.20 kg.	32.50
01-82	omni 12v car adaptor	1 oz.	.28 g.	5.00
LQE25	25' extension cable	2 <sup>3</sup> / <sub>4</sub> lbs	1.08 kg.	19.50
KCC	cable clips (40)	4 oz.	.11 kg.	9.00
K4CC	cable clips (10)	1 oz.	.28 g.	4.50
T1-61	tota-lampak	2 oz.	57 g.	12.50
01-61	omni-lampak	2 oz.	57 g.	12.50
T0-61	tota/omni lampak	2 oz.	57 g.	12.50
01-65	tota-packet	2 oz.	57 g.	11.50
T1-85	tota case	5 lbs.	2.27 kg.	85.00
T0-87	tota/omni molded case	10 lbs.	4.54 kg.	110.00
T0-83	tota/omni case	10 <sup>3</sup> / <sub>4</sub> lbs.	4.71 kg.	145.00
T0-84	tota/omni case	10 <sup>1</sup> / <sub>2</sub> lbs.	4.82 kg.	145.00
01-86	omni case	13 <sup>1</sup> / <sub>8</sub> lbs.	5.95 kg.	160.00
T0-89	heavy duty case	28 lbs	12.70 kg	395.00
T1-82	tota tube case	2 <sup>3</sup> / <sub>4</sub> lbs.	1.08 kg.	75.00

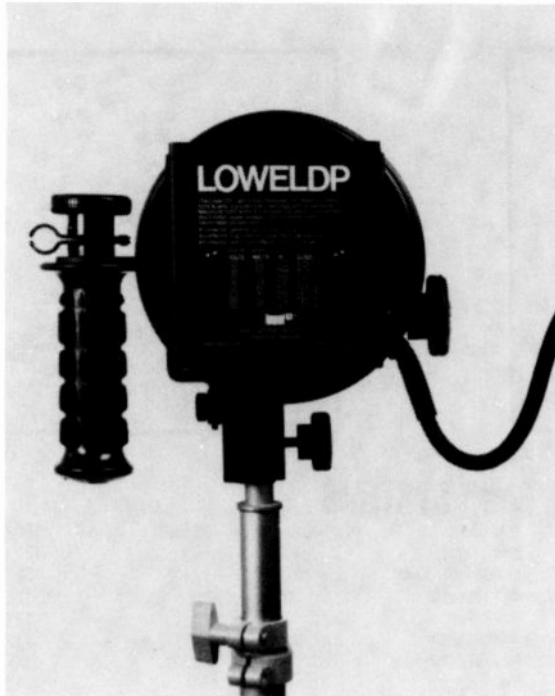

DP LIGHT

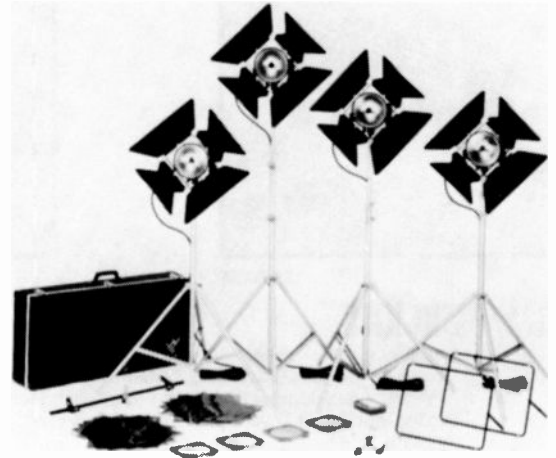

D2-97

## DP SYSTEM

CODE	ITEM	NET WEIGHT		PRICE LIST U.S. \$
D2-10	dp light	3 <sup>3</sup> / <sub>4</sub> lbs	1.76 kg	138.00
D2-15	= 1 reflector	2 oz	57 g	12.50
D2-17	= 3 reflector	2 oz	57 g	12.50
D2-18	= 4 reflector	2 oz	57 g	12.50
SEE SUPPLEMENT SHEET FOR LAMPS				
D2-20	complete barndoor	1 lb	45 kg	57.50
D2-21	barndoor frame	4 oz	11 kg	24.50
D2-22	rectangular leaf	4 oz.	11 kg	12.00
D2-23	triangular leaf	2 oz.	57 g	11.50
D2-50	diffused glass	4 oz	11 kg	27.50
D2-51	dichroic filter	4 oz	11 kg	104.00
D2-52	clear glass	4 oz	11 kg	26.00
D2-53	snoot	6 oz	17 kg	34.00
D2-54	full scrim	3 oz	85 g.	14.00
D2-55	half scrim	3 oz.	85 g	14.00
D2-56	graduated scrim	3 oz.	85 g	16.50
D2-57	cookaloris	3 oz	85 g	14.00
D2-24	dp frame	8 oz	.23 kg	38.50
GELS: PACKAGE OF 4. 12x16" (30x41cm)				
D2-69	blue frost gels	2 oz	57 g	13.50
D2-70	day blue gels	2 oz.	57 g	13.50
D2-71	n.d. 3 gels	2 oz	57 g	13.50
D2-72	frost gels	2 oz.	57 g	13.50
D2-78	mixed gels	2 oz	57 g	13.50
D2-25	dp brella	14 oz.	.40 kg	48.50
T1-50	flexi shaft 16" (2)	4 oz.	11 kg	16.50
T1-52	tota-flag	4 oz	11 kg	15.00
T1-54	tota-ffector	6 oz.	17 kg	19.50
LFT	lightffector/tilter	1 <sup>3</sup> / <sub>4</sub> lbs	.79 kg	75.00
KS	ks stand	4 <sup>3</sup> / <sub>4</sub> lbs.	2.10 kg	98.00
KP	full pole	1 <sup>3</sup> / <sub>4</sub> lbs.	.62 kg	46.00
KPH	half pole	1 lb	.45 kg	39.00
LC	lowel casters (3)	2 <sup>3</sup> / <sub>4</sub> lbs.	1.08 kg	45.00
LA	lowel anchors (4)	12 oz.	.34 kg	8.50
LW	lowel weight	4 <sup>1</sup> / <sub>4</sub> lbs.	1.93 kg.	22.50
SC-10	large space clamp	1 <sup>1</sup> / <sub>2</sub> lbs	.68 kg	48.50
SC-20	small space clamp	1 <sup>1</sup> / <sub>4</sub> lbs	.57 kg.	42.50
D2-32	tape up bracket	8 oz.	23 kg	27.50
GT-12	gaffer tape 12 yards	8 oz	.23 kg	8.50
GT-30	gaffer tape 30 yards	1 <sup>1</sup> / <sub>4</sub> lbs.	.57 kg	15.50

CODE	ITEM	NET WEIGHT		PRICE LIST U.S. \$
T1-30	tota-clamp	4 oz.	.11 kg	18.50
KI-10	interlink	12 oz	34 kg	21.50
KG	grip	1 <sup>3</sup> / <sub>4</sub> lbs.	.79 kg.	27.50
LSS	screw in stud (2)	4 oz	11 kg	9.00
LQE25	25' extension cable	2 <sup>3</sup> / <sub>4</sub> lbs.	1.08 kg.	19.50
KCC	cable clips (40)	4 oz	11 kg	9.00
K4CC	cable clips (10)	1 oz.	28 g	4.50
D2-61	dp lampak	2 oz	57 g	12.50
MCSE	multi case	14 <sup>1</sup> / <sub>2</sub> lbs	6.58 kg	160.00
D2-89	heavy duty case	37 lbs.	17 kg	425.00
D2-05	quartz d retrofit	8 oz.	23 kg	9.50

## DP KITS

CODE	ITEM	NET WEIGHT		PRICE LIST U.S. \$
D2-95	dp brella kit 3 dp lights, = 1 reflector (less lamps); 3 dp brellas; 3 ks stands; 1 dp lampak; 1 multi case	46 lbs.	21 kg.	975.00
D2-93	dp 3 kit 3 dp lights, = 1 reflector (less lamps); 3 dp barndoors; 3 ks stands; 1 dp lampak; 1 multi case	43 lbs.	20 kg.	995.00
D2-94	dp 4 kit 4 dp lights, = 1 reflectors (less lamps); 4 dp barndoors; 4 ks stands; 1 dp lampak; 1 multi case	53 lbs.	24 kg.	1285.00
D2-96	dp remote kit 3 dp lights, = 1 reflectors (less lamps); 3 dp barndoors; 1 = 3 superspot reflector; 1 diffused glass; 1 full scrim; 1 graduated scrim; 1 dp brella; 3 dp frames; 1 mixed gels; 1 pack day blue gels; 1 lightffector/tilter; 2 tota-flags; 2 flexi shafts; 3 ks stands; 1 large space clamp; 1 dp lampak; 1 multi case	50 lbs.	23 kg.	1390.00
D2-97	close quarters kit 4 dp lights, = 1 reflectors (less lamps); 1 = 3 superspot reflector; 4 dp barndoors; 2 full scrims; 1 half scrim; 1 graduated scrim; 2 dp frames; 1 mixed gels; 1 pack day blue gels; 4 ks stands; 1 large space clamp; 1 dp lampak; 1 multi case	56 lbs.	25 kg.	1500.00





Softlight 2



Lowel-light

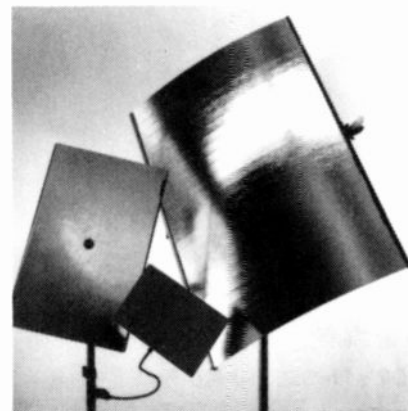

Reflectors

## SOFTLIGHT SYSTEM

CODE	ITEM	NET WEIGHT		PRICE
S2-10	softlight 2	8 lbs	3.63 kg	270.00
	<b>SEE SUPPLEMENT SHEET FOR LAMPS</b>			
S2-20	complete barn door	2 lbs.	91 kg	71.00
S2-21	top or bottom door	10 oz.	28 kg	29.00
S2-22	side barn door	5 oz.	14 kg	14.00
S2-30	reflector shell	6 oz	.17 kg	68.00
	GELS: PACKAGE OF 3, 24x34" (61x86cm)			
S2-69	blue frost gels	7 oz	.20 kg	29.50
S2-70	day blue gels	7 oz	20 kg	29.50
S2-71	n d 3 gels	7 oz	20 kg	29.50
S2-72	frost gels	7 oz	.20 kg	29.50
KS	ks stand	4 1/2 lbs.	2.10 kg	98.00
KP	full pole	1 3/4 lbs	.62 kg	46.00
KPH	half pole	1 lb	45 kg	39.00
SC-10	large space clamp	1 1/2 lbs.	.68 kg.	48.50
SC-20	small space clamp	1 1/4 lbs	.57 kg	42.50
KG	grip	1 3/4 lbs	79 kg.	27.50
KI-10	interlink	12 oz	34 kg.	21.50
T1-30	tota-clamp	4 oz	.11 kg	18.50
KWW	water weight	8 oz	.23 kg.	15.00
LW	lowel weight	4 1/4 lbs.	1.93 kg	22.50
LC	lowel casters (3)	2 3/4 lbs	1.08 kg.	45.00
KCC	cable clips (40)	4 oz	.11 kg	9.00
K4CC	cable clips (10)	1 oz.	28 g	4.50
T1-61	tota lampak	2 oz.	57 g	12.50
S2-51	softlight case	9 1/2 lbs.	4.31 kg	125.00
S2-53	softlight case	11 lbs	4.99 kg.	140.00
RU	roll up carrier	3 1/4 lbs.	1.47 kg	98.50
S2-06	softlight retrofit	1 1/4 lbs	85 kg	38.00

## SOFTLIGHT KITS

S2-92	standard soft kit	25 lbs.	11.34 kg.	550.00
	1 softlight 2 (less lamps); 1 ks stand; 1 complete set barn doors; 1 tota-lampak; 1 softlight case			
S2-91	light soft kit	20 lbs.	9.07 kg.	460.00
	1 softlight 2 (less lamps); 1 complete set barn doors; 1 tota-lampak; 1 softlight case.			
S2-93	triple soft kit	41 lbs.	18.59 kg.	1095.00
	3 softlight 2 (less lamps); 3 complete set barn doors; 1 tota-lampak; 1 softlight case.			

## LOWEL-LIGHT SYSTEM

CODE	ITEM	NET WEIGHT		PRICE
LL1	lowel light	10 oz	28 kg	31.50
BR40	barn door	4 oz	11 kg	30.00
BR-1	replacement flap	2 oz	57 g	8.00
GT-12	gaffer tape 12 yards	8 oz.	23 kg	8.50
GT-30	gaffer tape 30 yards	1 1/4 lbs	57 kg	15.50
K5C	lowel light case	2 1/4 lbs	.96 kg	65.00
K5BR	lowel light K5BR kit	8 1/4 lbs.	3.74 kg.	345.00
	5 lowel lights (less lamps); 1 12 yard gaffer tape; 5 barn doors; 1 lowel light case.			

## REFLECTORS

CODE	ITEM	NET WEIGHT		PRICE
LFT	lightflector/tilter	1 3/4 lbs.	.79 kg.	75.00
LF	lightflector	1 3/4 lbs.	.74 kg.	57.00
T1-54	tota-flector	6 oz	.17 kg.	19.50
V44A	variflector II	14 lbs.	6.35 kg.	265.00
V44RS	replacement panel	7 1/4 lbs.	3.29 kg.	110.00
V44CK	side channels (2)	3 1/2 lbs.	1.59 kg.	115.00
GS	grand stand	6 lbs.	2.72 kg.	165.00
KS	ks stand	4 1/2 lbs.	2.10 kg.	98.00
O1-33	omni-stand	2 3/8 lbs.	1.30 kg.	79.00
LA	lowel anchors (4)	12 oz.	.34 kg.	8.50
LW	lowel weight	4 1/4 lbs.	1.93 kg.	22.50
T1-36	tota-tilter	4 oz.	.11 kg.	20.00
T1-50	flexi shaft 16" (2)	4 oz.	.11 kg.	16.50
T1-30	tota-clamp	4 oz.	.11 kg.	18.50
T1-34	tota-tatch	2 oz.	57 g.	11.00
LC	lowel casters (3)	2 3/4 lbs.	1.08 kg.	45.00
V44CC	variflector case	4 1/4 lbs.	1.93 kg	88.00
V44SC	variflector II kit		11.34 kg.	495.00
	1 variflector II; 1 grand stand; 4 lowel anchors; 1 variflector case			

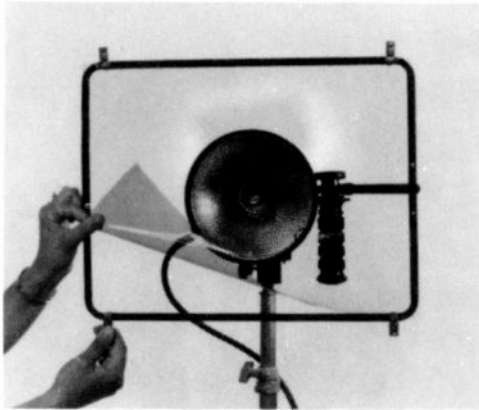

DP with GEL FRAME

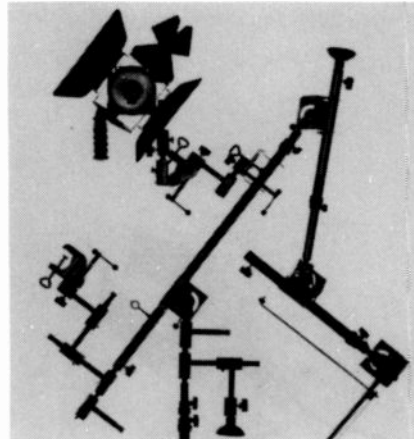

CLAMPS and MOUNTS

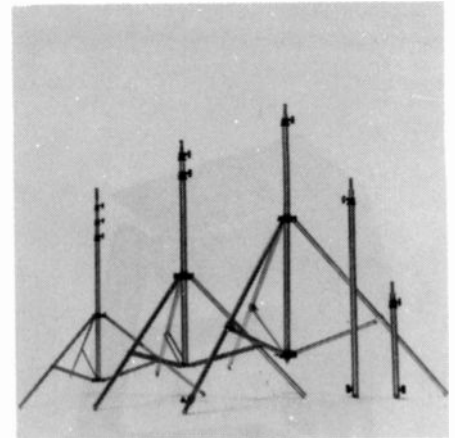

STANDS, POLES, BOOMS, RIGS

## FLAGS, GELS, UMBRELLAS

CODE	ITEM	NET WEIGHT		PRICE
T1-52	tota-flag	4 oz.	.11 kg.	15.00
T1-50	flexi shaft 16" (2)	4 oz.	.11 kg	16.50
T1-30	tota-clamp	4 oz.	.11 kg.	18.50
T1-34	tota-tatch	2 oz.	57 g.	11.00
T1-35	tota-daptor	4 oz.	.11 kg	15.00
T1-36	tota-tilter	4 oz.	.11 kg	20.00
T1-20	tota-frame	6 oz.	17 kg	24.50
D2-24	dp frame	8 oz.	.23 kg.	38.50
GELS:PACKAGE OF 5, 10x12" (25x30cm)				
T1-69	blue frost gels	2 oz.	57 g.	10.50
T1-70	day blue gels	2 oz.	57 g.	10.50
T1-71	n.d. 3 gels	2 oz.	57 g.	10.50
T1-72	frost gels	2 oz.	57 g.	10.50
T1-78	assorted gels	2 oz.	57 g.	10.50
GELS:PACKAGE OF 4, 12x16" (30x41cm)				
D2-69	blue frost gels	2 oz.	57 g.	13.50
D2-70	day blue gels	2 oz.	57 g.	13.50
D2-71	n.d. 3 gels	2 oz.	57 g.	13.50
D2-72	frost gels	2 oz.	57 g.	13.50
D2-78	mixed gels	2 oz.	57 g.	13.50
GELS:PACKAGE OF 3, 24x34" (61x86cm)				
S2-69	blue frost gels	7 oz.	.20 kg.	29.50
S2-70	day blue gels	7 oz.	.20 kg	29.50
S2-71	n.d. 3 gels	7 oz.	.20 kg	29.50
S2-72	frost gels	7 oz.	.20 kg	29.50
T1-25	tota-brella	8 oz.		30.00
D2-25	dp brella	14 oz.		48.50

## STANDS, POLES, BOOMS, RIGS

CODE	ITEM	NET WEIGHT		PRICE
GS	grand stand	6 lbs.	2.72 kg	165.00
KS	ks stand	4 3/4 lbs	2.10 kg.	98.00
O1-33	omni-stand	2 3/4 lbs	1.30 kg	79.00
KP	full pole	1 3/8 lbs.	.62 kg	46.00
KPH	half pole	1 lb	.45 kg.	39.00
LC	lowel casters (3)	2 3/8 lbs.	1.08 kg	45.00
LA	lowel anchors (4)	12 oz.	34 kg	8.50
LW	lowel weight	4 1/4 lbs.	1.93 kg.	22.50

CODE	ITEM	NET WEIGHT		PRICE
KWW	water weight	8 oz.	.23 kg	15.00
KCL	ceiling link	10 oz.	.28 kg.	18.50
T1-30	tota-clamp	4 oz.	.11 kg	18.50
KG	grip	1 3/4 lbs.	.79 kg	27.50
KI-10	interlink	12 oz.	34 kg	21.50
KI-11	double male stud	4 oz.	.11 kg.	5.50
MCSE	multi case	14 1/2 lbs.	6.58 kg	160.00
V44CC	variflector case	4 1/4 lbs.	1.93 kg	88.00
T1-82	tube case	2 3/8 lbs	1.08 kg	75.00
RU	roll up carrier	3 1/4 lbs.	1.47 kg	98.50
SP-90	big boom	20 1/2 lbs.	9.30 kg.	310.00
1 grand stand, 1 grip; 1 full pole; 2 lowel weights; 1 set lowel casters (3); 1 package cable clips (10).				
SP-91	basic boom	19 lbs.	8.62 kg.	250.00
1 ks stand, 1 grip; 1 full pole, 2 lowel weights; 1 set lowel casters (3); 1 package cable clips (10).				
SP-92	hi-lo-elbow	7 lbs.	3.17 kg.	155.00
1 ks stand; 1 grip; 1 half pole				
SP-93	background support	13 1/2 lbs.	6.12 kg.	315.00
2 ks stands; 2 interlinks, 2 full poles.				

## CLAMPS & MOUNTS

CODE	ITEM	NET WEIGHT		PRICE
SC-10	large space clamp	1 1/2 lbs.	0.68 kg	48.50
SC-20	small space clamp	1 1/4 lbs.	.57 g.	42.50
SC-15	large bar	8 oz.	.23 kg	22.00
SC-25	small bar	4 oz.	.11 kg	15.00
SC-30	stud bracket	4 oz.	.11 kg	11.50
SC-35	clamping arm (1)	6 oz.	.17 kg	10.00
KP	full pole	1 3/8 lbs	.62 kg	46.00
KPH	half pole	1 lb	.45 kg	39.00
T1-30	tota-clamp	4 oz.	.11 kg.	18.50
KG	grip	1 3/4 lbs.	.79 kg	27.50
KI-10	interlink	12 oz.	34 kg	21.50
KI-11	double male stud	4 oz.	.11 kg.	5.50
T1-32	tota-mount	10 oz.	.28 kg.	25.00
D2-32	tape up bracket	8 oz.	.23 kg.	27.50
GT-12	gaffer tape 12 yards	8 oz.	.23 kg	8.50
GT-30	gaffer tape 30 yards	1 1/4 lbs.	.57 kg.	15.50
LSS	screw in stud (2)	4 oz.	.11 kg.	9.00
T1-35	tota-daptor	4 oz.	.11 kg	15.00
T1-36	tota-tilter	4 oz.	.11 kg.	20.00
KCL	ceiling link	10 oz.	.28 kg.	18.50

# LUXOR

## Adjustable and Fixed-Height TV Tables

Luxor mobile TV Tables are available in adjustable and fixed-height models with or without cabinets.

All shelves measure 24" x 28". Every model is complete with a three-outlet, three-wire power assembly and 15' cord. Luxor tables are constructed of heavy-gauge welded steel for strength and durability. Legs are double-weight and rounded for strength and safety. Shelves have protective guardrails and rolled edges. Top shelves are double-reinforced and have a non-skid rubber mat. Big, 4" ball bearing, anti-shimmy, swivel casters — two with locking brakes. Charcoal finish. Cabinets have locking doors.

Adjustable-height tables can be easily positioned in any of six overall heights: 56", 54", 50", 48", 42", and 40". Cabinet height is 26".

Fixed-height TV Tables have top shelf tilted forward 8 degrees to reduce glare when viewing.

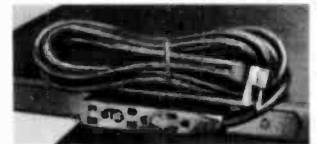
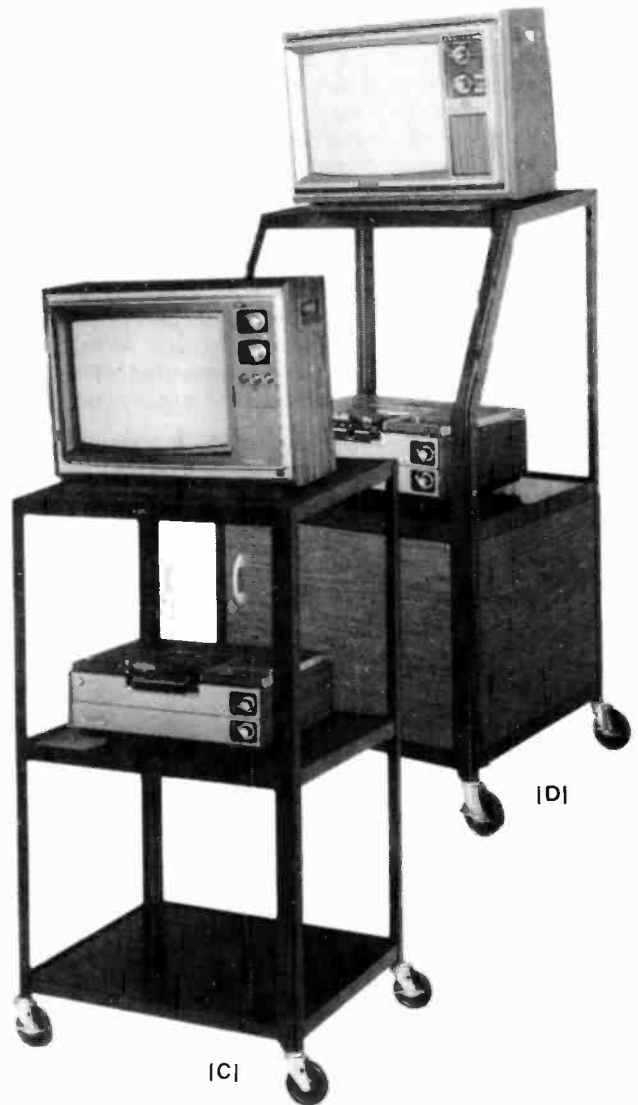

**[A] ATV-56 — ADJUSTABLE-HEIGHT TV TABLE** with 24" x 28" shelves. Adjusts to six heights of 56", 54", 50", 48", 42", and 40". Middle shelf is 26" from floor.

**ATV-56** ..... \$198.00

Monitors and recorders not included.

**[B] ATV-56C — ADJUSTABLE-HEIGHT TV TABLE WITH LOCKING CABINET** with 24" x 28" shelves. Cabinet base has walnut woodgrain vinyl clad steel panels and door. Adjustable to heights of 56", 54", 50", 48", 42", and 40". Cabinet height is 26". Door opening 17½" h x 24" w. Cabinet size 18½" h x 28" w x 24" d.

**ATV-56C** ..... \$339.00

**[C] TVR-54 — FIXED HEIGHT TV TABLE** with 24" x 28" shelves. Height is 54" with top shelf tilted forward eight degrees to reduce glare. 26" between top and center shelves; 25" center to bottom shelf.

**TVR-54** ..... \$147.00

**VTO-28 — VIDEO TAPE ORGANIZER** fits on any shelf. Holds up to 28 VHS, Beta or ¼" videocassettes. See page 2.

**VTO-28** ..... \$ 15.00

**[D] TVR-54C — FIXED HEIGHT TV TABLE WITH LOCKING CABINET.**

Top shelf is recessed 7 inches to provide clearance. Other shelves are 24" x 28". Height is 53½" with top shelf tilted forward eight degrees to reduce glare. 25¾" from top to center shelf. Cabinet base has walnut woodgrain vinyl clad steel panels and door. Compartment is 28" w x 24" d x 17½" h.

**TVR-54C** ..... \$308.00

Prices and Specifications Subject to Change Without Notice.

129

# LUXOR

## Designer Series Video Security Consoles

An entirely new concept in video consoles utilizing wood, steel and chrome construction. The DS Series achieves a sensational, attractive appearance in a highly functional cabinet. The black steel frame surrounds walnut woodgrain laminate and decorative chrome to form an exceptionally strong and stable piece of furniture.

The Designer Series is offered in three basic heights: 30", 40" and 55" high. The 30" models are ideal for use by small to medium viewing groups. The 40" models may be used with medium size groups. The 55" models raise the TV receiver to a level needed by larger groups. All models will accommodate VHS or Beta video player/recorders. Recorder shelf is slanted for easy access to controls.

Cabinet shelves and top have a raised safety-edge to prevent equipment from accidentally sliding off. Models are complete with a three-outlet, three-wire electrical power assembly and 15 foot cord.

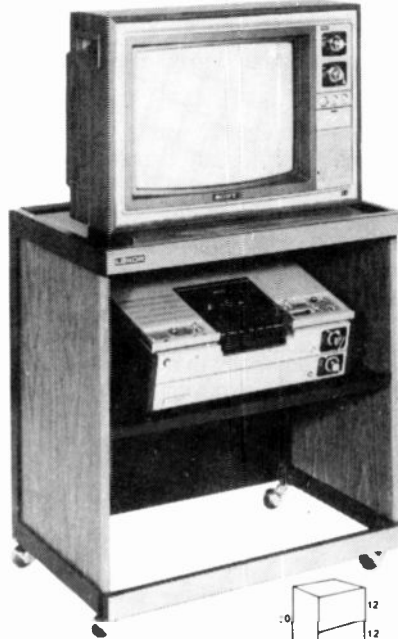

**DS-300 — 30" TWO-SHELF VIDEO CONSOLE** Console is 30" w x 30" h x 20" d. Compartments are 28" w x 18-7/8" d with 12" h between middle and top. 2" hooded ball casters. Assembly required.  
DS-300 .....\$198.00

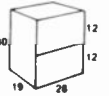

**DS-303 — 30" THREE-SHELF VIDEO CONSOLE** Console is 30" w x 30" h x 20" d. Compartments are 28" w x 18-7/8" d with 12" h between bottom and middle shelf and 12" h between middle and top. 2" hooded ball casters. Assembly required.  
DS-303 .....\$230.00

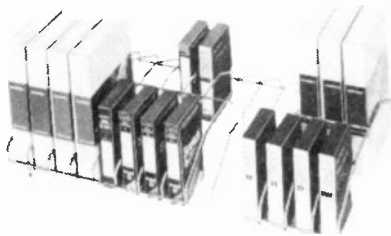

**VTO-28 — VIDEO TAPE ORGANIZER** fits any shelf. Chrome plated steel with rubber feet. Holds up to 28 VHS, Beta or 3/4" videocassettes. 25 1/4" w x 16" d x 4 1/4" h.  
VTO-28 .....\$15.00

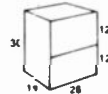

**DS-312 — 30" DUTCH DOOR VIDEO CONSOLE** Console is 30" w x 30" h x 20" d. Compartments are 28" w x 18-7/8" d with 12" h between bottom and middle shelf and 12" h between middle and top. Locking doors secure your valuable tapes. 2" hooded ball casters. Assembly required.  
DS-312 .....\$270.00

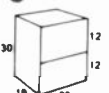

**DS-325 — 30" FULL DOOR VIDEO CONSOLE** Console is 30" w x 30" h x 20" d. Compartments are 28" w x 18-7/8" d with 12" h between bottom and middle shelf and 12" h between middle and top. Full locking doors secure your tapes and receiver. 2" hooded ball casters. Assembly required.  
DS-325 .....\$288.00

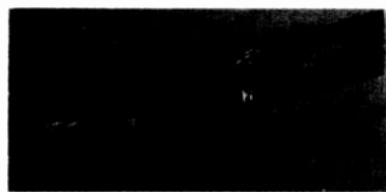

All Designer Series models are complete with a three-outlet, three-wire electrical power assembly and a 15 foot cord. Recessed in rear wall of cabinets for safety.

Monitors and recorders not included.



## VIDEO DELAY LINES

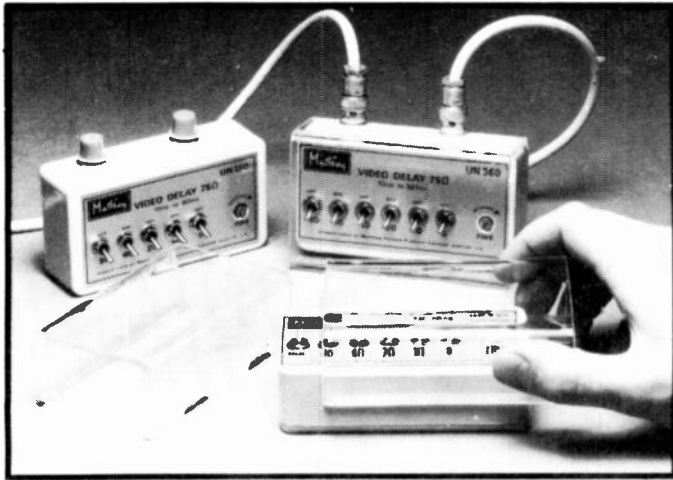

### INFINITELY VARIABLE VIDEO DELAY BOXES

Two models provide infinitely variable video delay (by means of toggle switches and a +/- 4 ns trim) over the following ranges:

Description	Cable Equivalent	Type	1-10	11-50
10-165 ns	7-107'	UN180	\$168.00	\$152.00

Performance: Insertion loss/frequency 0.1 dB at low frequency and 0.4 +/- 0.1 dB at 4.43 MHz.

10-325 ns equalized	7-211'	UN360	\$389.00	\$350.00
---------------------	--------	-------	----------	----------

Performance: Flat loss at 100 KHz at max. delay is 0.9 dB +/- 0.2 dB. Return loss is greater than 20 dB up to 5.5 MHz. Amplitude/frequency response — ripple less than 0.4 dB up to 5.5 MHz for any delay.

	Type	
Protective Lucite Cover for UN180 and UN360	MLC	\$13.00

### VIDEO DELAY TRIMMER (rubber coax)

An infinitely variable delay range of 3 to 9 ns packaged in a small metal box with BNC connectors — video performance. Recessed screw adjustment permits trimming equivalent to 2-6 feet ccax cable.

Range	Cable Equivalent	Type	1-10	11-50
3-9 ns	2-6'	UN3/9	\$75.00	\$66.00

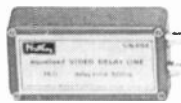
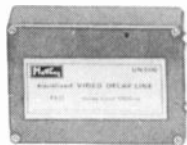

### FIXED EQUALIZED VIDEO DELAY BOXES

75 — BNC Connectors — 5.5 MHz

The following equalized lump delay boxes can be cascaded and mixed with UN180 and UN360 to achieve delays to 2000 ns. Amplitude ripple is within 0.2 dB up to 5.5 MHz. A 10 MHz range is also available.

### NEW — ADJUSTABLE VIDEO DELAY BOXES — 75Ω

A metal box with BNC connectors containing fixed and segmented video delays in increments of 5 ns with a fine trim of +/- 4 ns by screwdriver adjustment on the outside of the box. Instructions inside each box for connection of segmented sections by customer.



### PULSE AND BLANKING DELAY BOX — 75Ω

A metal box with BNC connectors containing pulse delays and instructions for tapping off required delay.

Range	Cable Equivalent	Type	1-10	11-50
in increments of 5 ns				
5-155 ns	3 1/2-100	UN068/A	\$ 91.00	\$ 82.00
160-1655 ns	104-1067	UN068/B	210.00	190.00
1660-3155 ns	1070-2055	UN068/C	409.00	355.00
In increments of 100 ns				
100-1500 ns	66-967	UN068/1	\$182.00	\$158.00
1600-3000 ns	1032-1935	UN068/2	329.00	286.00
3100-4500ns	2000-2903	UN068/3	477.00	414.00

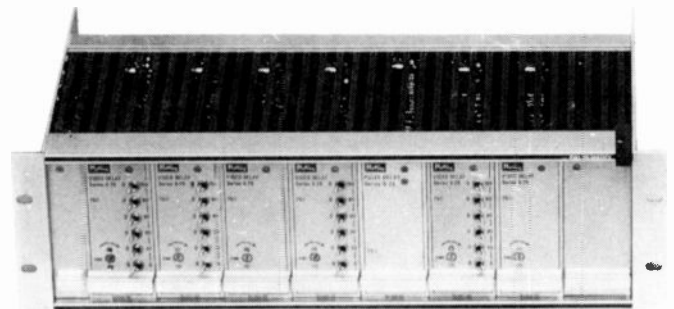

### RACK-MOUNTED EQUALIZED VIDEO DELAYS 5.25 SERIES

5.25 Series Rack Frame	\$155.00
5.25 Series Blank Panel	\$ 24.00

The 5.25 Series delay line cards are available either with switches (Part No. 5.25/8-) or adjustable (without switches, Part No. 5.25/1A). Both cards have BNC connectors on the back. Up to 8 cards can be accommodated by one rack frame.

The switched version provides 310 ns of infinitely variable delay with 26 switches and the +/- 4 ns vernier. The version without switches has the +/- 4 ns vernier and is normally supplied with the final 150 ns segmented range unconnected. You connect this final segmented portion in 5 ns increments using the +/- 4 ns vernier for fine trim until correct timing is achieved.

With either version, should timing requirements change, Matthey delay line PC modules can be added or subtracted to accommodate any delay requirement from 10 to 2100 ns.

### SWITCHABLE VIDEO DELAY CARDS

5.25/B Series — Six switches and the +/- 4 ns vernier provide 310 ns of infinitely variable delay — equalized to 5.5 MHz and padded to 3 dB.

Video Delay Range	Type	Price
10-320 ns	5.25/B2	\$ 542.00
310-620 ns	5.25/B3	720.00
610-920 ns	5.25/B4	857.00
910-1220 ns	5.25/B5	955.00
1210-1520 ns	5.25/B6	1136.00
1510-1820 ns	5.25/B7	1193.00
1810-2120 ns	5.25/B8	1451.00

# MICROTIME

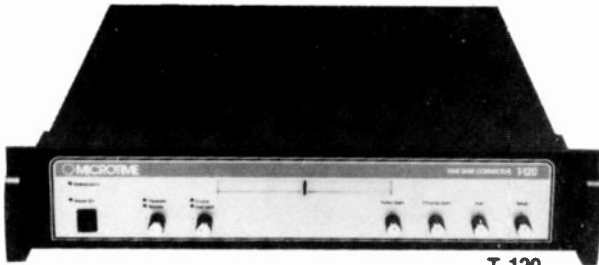

T-120



Video Image Processor 2100



Video Signal Synchronizer 2525



TBC Frame Synchronizer 2520

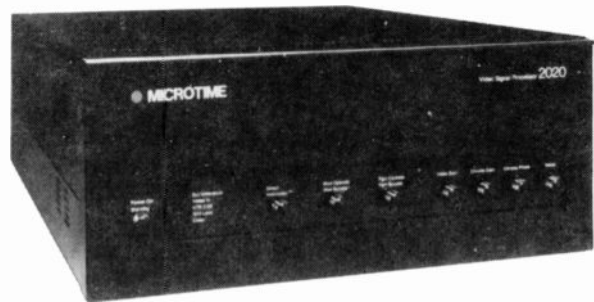

Video Signal Processor 2020

## VIDEO PRODUCTS

### Video Signal Synchronizer 2525

075904-501 VIDEO SIGNAL SYNCHRONIZER for complete signal processing of any video source. A full performance Frame Synchronizer/Time Base Corrector including Line Error Detection, Field 1, Field 2, or Frame Freeze — all locked to station through the 2520. On location, switch multi-cameras feeds through the 2520 for "invisible" hot switches. The 2520 is a full-function infinite window time base corrector with Microtime's exclusive Hetrocolor™ correction. Use it in the studio as a dedicated TBC, or feed remote VTR or VCR video for lock to station or live playback. No link to the VTR is necessary — just the video feed via Telco, microwave or satellite.

**\$16,900.00**

### TBC Frame Synchronizer 2520

The 2520 synchronizer gives you the highly transparent performance of the 2525 at an attractive price. Synchronize network incoming, remotes, satellite feeds — all locked to station through the 2520. On location, switch multi-cameras feeds through the 2520 for "invisible" hot switches.

The 2520 is a full-function infinite window time base corrector with Microtime's exclusive Hetrocolor™ correction. Use it in the studio as a dedicated TBC, or feed remote VTR or VCR video for lock to station or live playback. No link to the VTR is necessary — just the video feed via Telco, microwave or satellite.

**\$15,495.00**

### Video Image Processor 2100

075966-501 STANDALONE IMAGE CORRECTION SYSTEM for any video signal. Provides 6 dB video noise reduction in luminance and chrominance, horizontal detail synthesis, vertical aperture correction, automatic group delay correction, comb filtering to remove cross color errors, chroma crispening and hue error reduction. Includes one Operation and Service Manual.

**\$4,950.00**

Video Image Process (Model 2121) available also as option to Microtime 2020 Series.

### Video Signal Processor 2020

076089-501 VIDEO SIGNAL PROCESSOR designed with modular option flexibility for any signal correction application. Standard features include Auto Trac 2, 4 H-line Correction Range with optimum digital Signal-to-Noise Ratio of 58 dB and internal RS-170A Sync Generator. Includes one Operation and Service Manual.

**\$12,995.00**

#### OPTIONS

075965-501 2121 Video Image Processor image correction system, companion, plug-in.

**\$5,995.00**

075075-502 Wide Window, 24 H-lines of correction range, (Velcor not available with Wide Window).

**\$1,995.00**

074760-501 Line Error Detection for segmented VTRs. (VTR must have front porch head switch).

**\$1,095.00**

075204-501 Velcor Velocity Correction System.

**\$1,295.00**

074795-502 DOC Dropout Compensation System, includes DOC, 317B, 316RF Buffer and 265-505 cards.

**\$1,095.00**

075116-501 No Lock Color, plug-in card.

**\$ 545.00**

074717-501 Image-Ex image correction system, plug-in cards.

**\$2,095.00**

### Heterodyne Time Base Corrector T-120

The T-120 is engineered to obtain best results from non-segmented 1/2" and 3/4" VTR's. Its low cost and high performance design offer unparalleled performance for a wide range of broadcast, CCTV and CATV applications.

At the same time, its processing power provides many new and exciting features; 8 bit, 4x subcarrier digital design for high reliability and transparent performance; Wide range, 16-H line memory allows correction of large gyro errors; 3.58 MHz feedback for full bandwidth processing; and, Averaging Velocity Correction for best color performance.

**\$9,950.00**



S-130

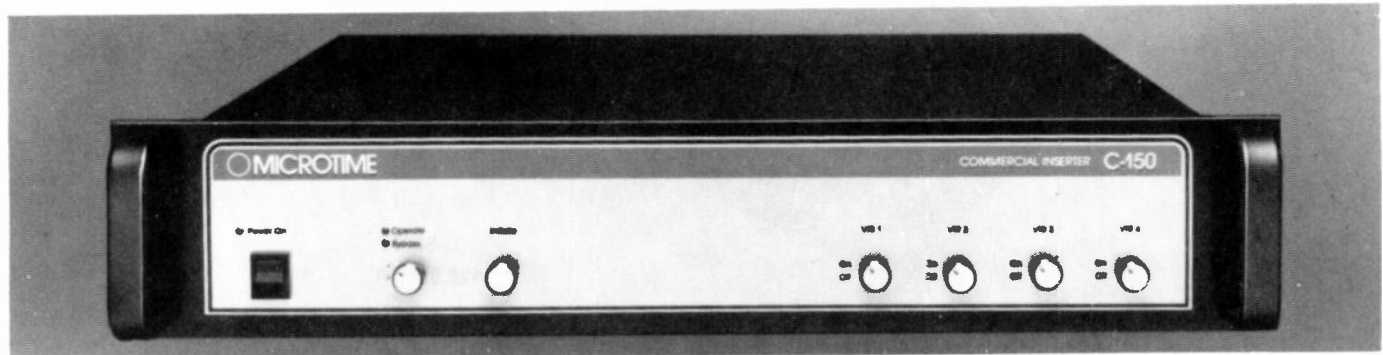

C-150

### Full Frame Synchronizer S-130

The S-130 synchronizes external signals such as ENG, microwave, satellite, network and remote studio feeds, allowing easy interface with studio switching systems. For CATV applications, the S-130 synchronizes video signals necessary for the new Harmonically Related Carrier (HRC) system designs.

The S-130 is available in three major video formats — NTSC, PAL, and PAL-M. Some of the unit's features are:

- Full Frame storage processes VITS, VIRS and Teletext information.
- Microprocessor directed memory hysteresis.
- Operator-initiated microprocessor controlled self-test.
- Selectable auto freeze or auto black with loss of input signal.
- Manual selection of Field 1, Field 2, or Full Frame Freeze.
- Independent adjustment of horizontal and burst output phase, with respect to black burst reference signal.
- Controlled sync, burst, and blanking rise times.
- Automatic color/mono detection and switching.
- Differential video input.
- Light weight, small size, and low power consumption.

**\$10,990.00**

### Automatic Commercial Inserter C-150

The C-150 was designed for use in satellite, CATV and closed circuit applications that require fully automatic local ad or program insertion.

The C-150 is a machine controller which will control up to 4 VTR's either automatically using coded tones from present satellites or manually from a switch closure command. The C-150 is equipped with the following features:

- Total automatic operation.
- Multiple selection of satellite network tone decode sequences.
- Adjustable pre-roll cues.
- Built-in audio, follow video switcher.
- Audio-Video bypass default system detects and bypasses to local slate or message without any loss of video
- Automatic TBC interface.

**\$4,995.00**



## GRAPHICS GENERATOR SYSTEM



D-8800  
\$28,990.00

### DESCRIPTION

The 3M-Datavision Model D-8800 Titling System is a modern television titling and graphics production system designed around microprocessor technology. The Model D-8800 is a true GRAPHICS PRODUCTION tool designed specifically for television use. It utilizes the latest available microprocessor technology and powerful operating programs to allow broad creative freedom and system control.

The Model D-8800 Titling System design is based on the concept of maximizing software control to produce a SIMPLE TO OPERATE yet flexible and complete television graphics system. Software control provides the inherent capability to update the Model D-8800 over the years without incurring extensive hardware modification, and special application or customer requirements can be more easily accommodated by software changes to the internal operating program.

The Model D-8800 Titling System features a carefully designed and human-engineered INTER-ACTIVE control console which helps to make the system easy to operate. An alpha-numeric panel display is part of the control console and, in conjunction with the operating program, will "walk" a new operator through operation while an experienced operator can ignore or override the cueing instructions.

The Model D-8800 Titling System provides the basic features expected in modern television-graphics devices:

- Multi-font display
- Proportional character spacing
- Full editing capability
- High resolution character definition
- Multi-speed roll and crawl

- Floppy disc support memory
- Auto centering, line and page
- Character-by-character color control
- Vertical roll up and down
- Horizontal crawl left and right
- Programmable roll-crawl masking

In addition, the Model D-8800 incorporates the following options:

- Dual channel output with mix capability
- Additional font memories
- Colorizer/keyer
- Custom fonts and logos
- Additional keyboards
- Additional disc storage

Carrying on the tradition of earlier Datavision Titling Systems, the Model D-8800 also features a powerful Animation Mode which allows creation of unusual and special graphic effects not otherwise obtainable. The Animation Mode may be used with any standard available font, or a special Line Segment font.

And speaking of fonts, the Model D-8800 is supported by an immediate library of fonts available in various sizes. An ongoing program will continually add to the library, and custom font design for customers will be accommodated.





# ROUTING SWITCHERS

## 15X SERIES

The Series 15X Routing Switcher offers an inexpensive method of eliminating patch panels and providing selectable distribution of audio and video signals. Any output channel can be independently programmed to select any input signal. The 15X Series offers very flexible control options which are divided into two categories — local and remote which can be intermixed within the same frame. Units are available in sizes: 2 outputs, 6 outputs, and 12 outputs. Also available with Audio Breakaway.

Plug-in input and output amplifiers are used for video and audio. The audio input amplifiers incorporate balanced inputs with common mode rejection for cancelling hum on input lines. The video inputs have looping BNC connectors and terminating switches.

LOCAL CONTROL		REMOTE CONTROL	
DESCRIPTION	PRICE	DESCRIPTION	PRICE
12 in x 3 out	\$2,273.00	12 in x 3 out	\$3,528.00
12 in x 4 out	2,772.00	12 in x 4 out	4,009.00
12 in x 5 out	3,080.00	12 in x 5 out	4,482.00
12 in x 6 out	3,442.00	12 in x 6 out	4,973.00
12 in x 7 out	4,173.00	12 in x 7 out	5,972.00
12 in x 8 out	4,478.00	12 in x 8 out	6,553.00
12 in x 9 out	4,782.00	12 in x 9 out	7,038.00
12 in x 10 out	5,086.00	12 in x 10 out	7,517.00
12 in x 11 out	5,392.00	12 in x 11 out	7,998.00
12 in x 12 out	5,698.00	12 in x 12 out	8,481.00
15 in x 3 out	2,473.00	15 in x 3 out	3,745.00
15 in x 4 out	3,016.00	15 in x 4 out	4,254.00
15 in x 5 out	3,389.00	15 in x 5 out	4,762.00
15 in x 6 out	3,851.00	15 in x 6 out	5,542.00
15 in x 7 out	4,531.00	15 in x 7 out	6,400.00
15 in x 8 out	4,867.00	15 in x 8 out	7,102.00
15 in x 9 out	5,228.00	15 in x 9 out	7,883.00
15 in x 10 out	5,714.00	15 in x 10 out	8,619.00
15 in x 11 out	6,199.00	15 in x 11 out	9,443.00
15 in x 12 out	6,684.00	15 in x 12 out	10,223.00

DESCRIPTION	OPTIONS	PRICE
Vertical Interval Switching (remote only)		Add \$350.00
Audio Input/Output Cable (6' pigtailed)	6 out frame	\$170.00
	12 out frame	\$340.00
Remote Control Cable (assembled and tested)		\$50.00 per cable + \$1.00/ft.

## 15X-2 SERIES

### 15X-2 Series Video/Audio Routing Switchers

Description	LOCAL CONTROL		REMOTE CONTROL	
	Video Only	Audio/Video	Video Only	Audio/Video
15 in x 1 out	\$1,773.00	\$2,070.00	\$1,970.00	\$2,270.00
15 in x 2 out	1,985.00	2,335.00	2,385.00	2,735.00



15X-2

DESCRIPTION	OPTIONS	LIST PRICE
Vertical Interval Switching (remote only)		Add \$350.00
Remote Control Cable (assembled and tested)		Add \$50.00 + \$1.00/ft.

- Second Audio Level Switching ..... Add \$1240.00 for 6 out frames  
Add \$1475.00 for 12 out frames
- Tally Relays ..... Add \$280.00
- X/Y Control, from remote control ... Add \$945.00/Sub \$50.00/output
- Touchpad Control ..... Add \$370.00/output

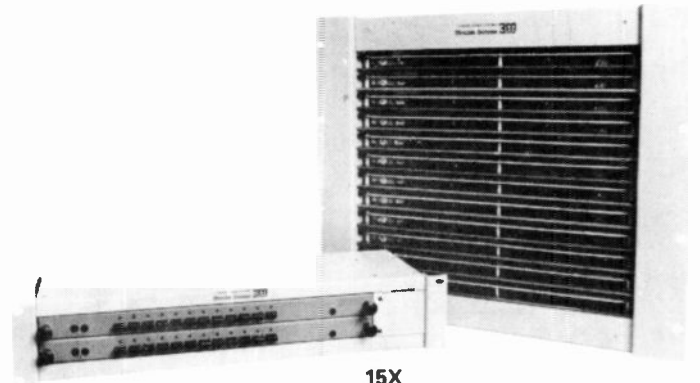

15X

**15X Series Video/Audio Routing Switchers** • Bridging Crosspoints • Choice of Local or Remote Controls • Modular—Field Expandable • Three Frame Sizes • Low Crosstalk • Second Audio Level (optional) • LED Status Indicators • Input and Output Amps • Terminating Switches on Inputs • Audio Breakaway

### Local Control

Mechanically interlocked pushbutton switches are used to select and switch the audio, video and tally signals.

Each video crosspoint is isolated from feeding back through the switch to the newly selected signal eliminating the glitch on other monitors. Each output has a separate plug-in tray containing the mechanical switch as well as the audio and video output amplifiers which are also separate plug-in units. LED status indicators above each pushbutton illuminate when the corresponding switch is depressed.

### Remote Control

Standard remote controls are available for momentary pushbuttons. Remote control pushbutton trays are interchangeable with the local modules. Only D.C. voltages are used for control. Switch module assemblies are available in 12 x 1 and 15 x 1 sizes.

## 101 SERIES

### Model 101 Vertical Interval Bridging Switcher

A 10 x 1 bridging switcher with built-in video and audio DA's featuring vertical interval switching on all inputs; lighted push buttons; and switch position memory. The switch position memory is effective for at least 30 seconds, and longer when connected to an external battery source (terminals provided)

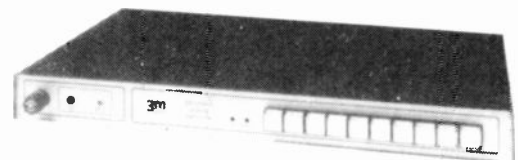

101

80-9700-0077-6 Vertical Interval Bridging Switcher ..... \$1,195.00

- Accessories:**
- 80-970C-0094-1 Remote Control ..... \$450.00
  - 80-970C-0080-0 Instruction Manual ..... 30.00  
(one supplied with unit)

## AUTOMATIC VIDEO TELECONFERENCE SYSTEM



# MISAR 1

- Self Contained Portable System
- Simple Start Up — No Operators Required
- Automatic Voice Actuated Camera Switching
- Expandable up to 5 Cameras
- 6 Hour Record Capability on One Tape
- Built-in Date and Time Generator Automatically Logs Meeting on Tape
- Fast Search Recall for Instant Replay of Selected Segments
- Designed for Small Meetings or Large Conferences ( 2-20 People)
- Plugs Directly Into Satellite Feed
- Tapes can be Reviewed at Home on Standard Home VCRS

The MISAR I Automatic Video Teleconference System harnesses a unique microprocessor controller to automatically provide an economical, fully documented, audio/video record of small meetings or large conferences. The output of the system may also be fed simultaneously to a satellite feed.

MISAR I is a portable, self-contained, easy to set-up system that requires no operators. The system operates in a normal office environment and requires no special power or lighting. MISAR I is expandable to five cameras (black and white or color) including an optional document storage capability.

MISAR is the first economical way to precisely document any meeting or conference. It's perfect for staff meetings, design review conferences, legal depositions, medical consultation sessions, contract negotiations, or any meeting where immediate or future review is important.

**\$19,950.00**

# NEC

## MONITOR/ TUNER-TIMER

### C19-709A 19" COLOR VIDEO MONITOR

#### FEATURES

- Precision, in-line black strip picture tube for clear sharp picture.
- Comb filter and wide band video circuit for improved resolution.
- Complete connector panel with 8-pin plug, BNC connectors for video in and out and RCA type connectors for audio in and out.
- Various automatic color control circuits to assure stable, high picture quality.
- Built-in 4" round speaker for audio monitoring.
- DC restoration circuit.

\$600.00



### C13-304A 13" COLOR MONITOR/RECEIVER

Excellent color performance is provided by NEC's C13-304A 13-inch (diagonal) color receiver/monitor. Whether you desire playback from a VTR, direct feed from a video camera, or just viewing off-air signals, this receiver/monitor offers top quality.

For skew-free VTR playback, fast time-constant circuitry is incorporated. A complete connector panel is provided to meet any production requirement.

#### Automatic Control Systems:

- Automatic Fine Tuning (AFT)
- Automatic Gain Control (AGC)
- Automatic Frequency Control (AFC)
- Automatic Chroma Gain Control (ACC)
- Automatic Color Killer
- Automatic Degaussing
- Automatic Brightness Control
- Automatic Voltage Control
- Automatic Pass Control

\$610.00

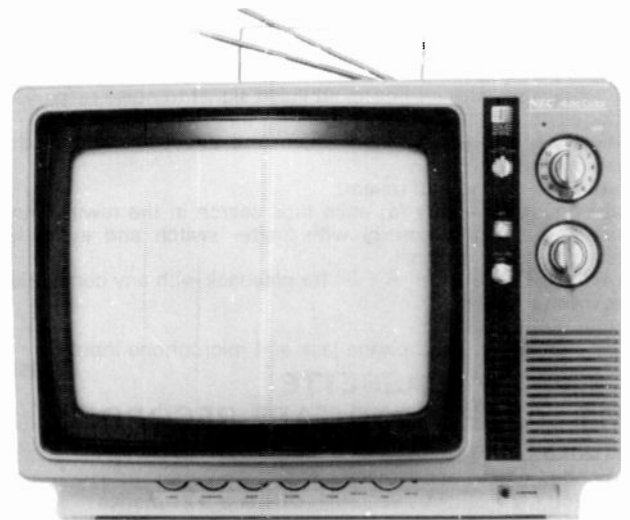

### TU-820EN TUNER-TIMER

#### FEATURES

- Microcomputer tuning system allows automatic preset of up to 12 TV channels.
- Full-function wireless remote control offers direct access channel selection, audio volume, audio muting and power on/off.
- Programmable timer can be preset for automatic VTR recording of one event in 24 hours.
- Built-in 3-position video/audio switcher permits convenient connection to 2 external video and audio sources.
- BNC connectors allow interface to professional video projectors or video monitors for off-air color TV viewing and to professional video tape recorders for off-air color TV recording.
- Compact modular design fits hi-fi component racks.

\$450.00

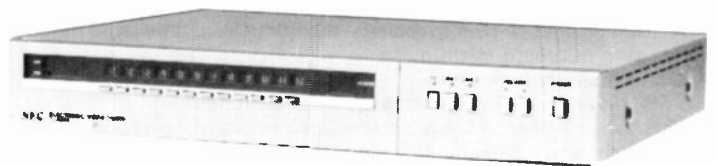

# NEC

## VC-9207 (M) U-MATIC COLOR CASSETTE VIDEO TAPE PLAYER

### FEATURES

- Solenoid operation for feather touch operation.
- Logic memory circuit allowing direct switching operating modes without going through stop mode.
- Remote control capability with optional remote control unit, RB-801.
- Pause/still frame with still frame adjustment for stable still picture playback.
- Advanced circuitry for improved video signal to noise ratio 48 dB.
- Rugged aluminum diecast chassis for long term alignment.
- Unique tape threading mechanism and direct drive head drum system.
- Automatic rewind and repeat.
- Tape counter memory for easy tape search in the rewind mode.
- Built-in RF modulator for playback with any conventional television receiver.
- 8 pin connector and headphone jack.

\$1,470.00

## VC-9307 (M) U-MATIC COLOR CASSETTE VIDEO TAPE PLAYER/RECORDER

### FEATURES

- Solenoid operation for feather touch operation.
- Logic memory circuit allowing direct switching between operating modes without going through stop mode.
- Remote control capability with optional remote control unit, RB-801.
- Pause/still frame with still frame adjustment for stable still picture playback.
- Advanced circuitry for improved video signal to noise ratio, 48dB.
- Rugged aluminum diecast chassis for long term alignment.
- Unique tape threading mechanism and direct drive head drum system.
- Automatic rewind and repeat.
- Tape counter memory for each tape search in the rewind mode.
- Manual audio gain control with limiter switch and audio level meters for each channel.
- Optional RF modulator, R-F 34 for playback with any conventional television receiver.
- Audio dub capability.
- 8 pin connector, head phone jack and microphone inputs.

\$1850.00

## VC-9507 3/4" CASSETTE TIME LAPSE VIDEO TAPE RECORDER

### FEATURES

- Expanded record and playback time:  
Realtime (72 minutes), 9H, 18H, 64H and 90H modes
- Multiple playback modes:  
Slow motion (Realtime recording/time lapse playback)  
Quick motion (Time lapse recording/realtime playback)  
Still frame  
Short reverse
- Full remote control capability:  
Fast forward, Forward, Stop, Rewind, Record, Audio Dub, Time Select, Still Frame, Reverse/Play, Field Advance
- Automatic time control switch allows outboard timer to operate in conjunction with VTR
- Clean quick motion and still frame playback
- Field advance button
- Tape counter with memory switch
- Auto rewind at end of tape and tape-end alarm
- Automatic change over to realtime recording from time lapse mode by using outboard alarm pulse
- Alarm memory indicator
- VTR trigger output pulse for sequential switchers
- VTR usage meter to show accumulated hours of operation
- Tape protection circuitry including dew sensor/heater, drum rotation sensor and take-up reel stoppage sensor
- Full solenoid operation with "feather touch" control buttons
- Full logic circuit to allow switching between all modes without going through stop
- Automatic gain control operation of audio and video channels
- Audio dubbing capability for audio channel

\$2,950.00

## VIDEO TAPE PLAYER/RECORDER



## HYDRO-PED CLAW BALL TRIPODS

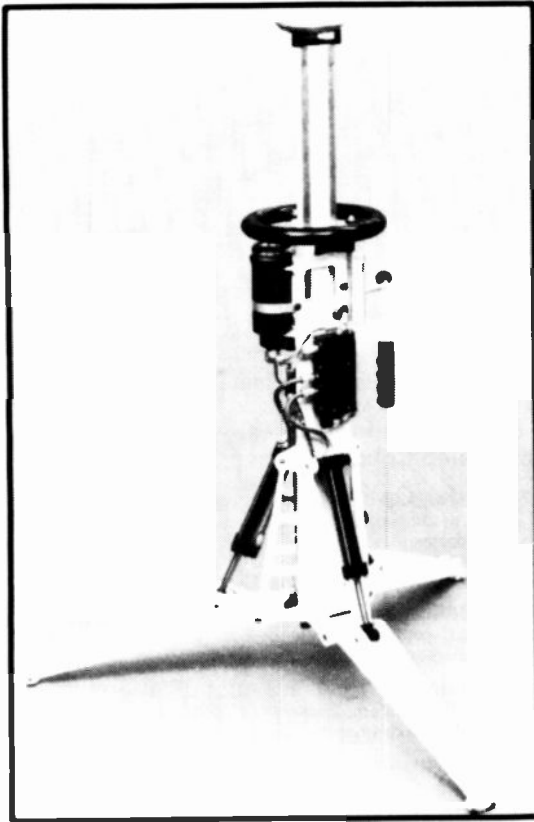

**Claw Ball Tripods**  
(price does not include Ball)

For use with Models C, 20, 30, and 50

Regular Claw Ball Tripod (39" to 67")	345.00
Baby Claw Ball Tripod (18" to 26")	345.00
Claw Ball Hi Hat (5½")	105.00
Claw Ball Tripod Top Casting only (replacement)	120.00

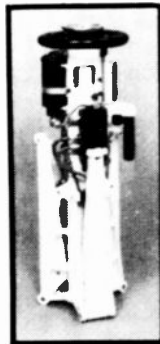
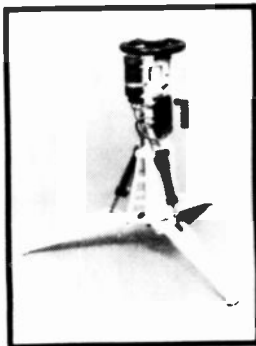

**Hydro-ped Model 102-B** ..... \$3950.00  
Including the following standard accessories

Pro Jr Top Plate

### Factory Order Options

Add the following amount when substituted for the above standard accessories.

Mitchell Top Plate ..... N/C

### Accessories

Pro Jr Top Plate for Hydro-ped	115.00
Mitchell Top Plate for Hydro-ped	115.00
Set of Wheels for Hydro-ped (2 fixed, 1 castor)	280.00
Set of Wheels for Hydro-ped (3 castors)	280.00



**Super Claw Ball Tripods**  
(price does not include Ball)

For use with Models 100 and 150

Standard Super Claw Ball Tripod (50" to 79")	545.00
Regular Super Claw Ball Tripod (46" to 66")	545.00
Sawed off Super Claw Ball Tripod (37" to 57")	545.00
Baby Super Claw Ball Tripod (26½" to 34½")	545.00
Super Claw Ball Hi-Hat (6")	155.00
Super Claw Ball Tripod Top Casting only (replacement)	160.00

## FLUID CAMERA HEADS

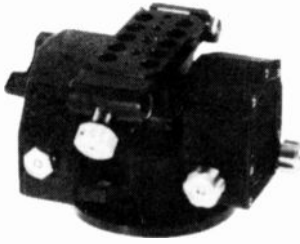

**Model 30** ..... \$995.00  
Including the following standard accessories.

Standard Handle (1/2" diameter, 10" length)  
Quick Release Camera Platform (with Removable Lisand  
type Camera Mounting Plate)  
Flat Base  
Adjustable Counterbalance Spring with Adjustment  
Wrench

### Factory Order Options

Add the following amount when substituted for the above  
standard accessories.

Adjustable Balance Quick Release Camera Platform  
(with removable Cine 60 Type Camera Mounting Plate, for use with  
one or two handles - extra handle not included) ..... **55.00**  
Adjustable Balance Quick Release Camera Platform  
(with removable Lisand Type Camera Mounting Plate, for use with  
one or two handles - extra handle not included) ..... **55.00**  
Pro Jr Flat Base ..... **55.00**  
Claw Ball Base ..... **55.00**  
Arri 16 Ball Base ..... **55.00**  
Arri 35 Ball Base ..... **70.00**

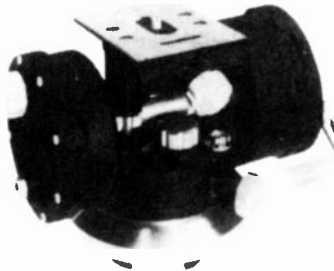

**Model 100-C** ..... \$2750.00  
Including the following standard accessories.

Standard Handle (5/8" diameter, 15" length)  
Fixed Camera Platform  
Mitchell Base with tiedown assembly  
500 Inch-Pound Counterbalance Spring

### Factory Order Options

Add the following amount when substituted for the above  
standard accessories.

Extended Handle for Video (3/4" diameter, 26" length) . . . **70.00**  
Adjustable Balance Quick Release Camera Platform (Side-  
Mount)  
(with removable Camera Mounting Plate, for use with one or  
two handles - extra handle not included) ..... **375.00**  
Pro Jr Base ..... **N/C**  
Arri 35 Ball Base ..... **N/C**  
Super Claw Ball Base ..... **75.00**  
300 Inch-Pound Counterbalance Spring ..... **40.00**  
700 Inch-Pound Counterbalance Spring ..... **65.00**

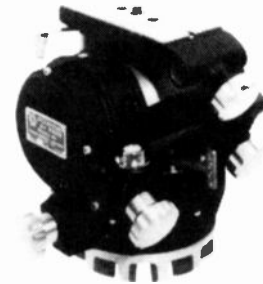

**Model 50-D** ..... \$1895.00  
Including the following standard accessories.

Standard Handle (1/2" diameter, 15" length)  
O'CONNOR Quick Release Camera Platform  
(with Removable Camera Mounting Plate)  
Pro Jr Base with tiedown assembly  
150 Inch-Pound Counterbalance Spring

### Factory Order Options

Add the following amount when substituted for the above  
standard accessories.

Fixed Camera Platform ..... **N/C**  
Adjustable Balance Quick Release Camera Platform  
(with removable Cine 60 Type Camera Mounting Plate, for use with  
one or two handles - extra handle not included) ..... **65.00**  
Adjustable Balance Release Camera Platform  
(with removable Lisand Type Camera Mounting Plate, for use with  
one or two handles - extra handle not included) ..... **65.00**  
Pro Jr/Flat Base ..... **N/C**  
Claw Ball Base ..... **N/C**  
Arri 16 Ball Base ..... **N/C**  
Arri 35 Ball Base ..... **15.00**  
Mitchell Base ..... **30.00**  
100 Inch-Pound Counterbalance Spring ..... **25.00**  
200 Inch-Pound Counterbalance Spring ..... **60.00**

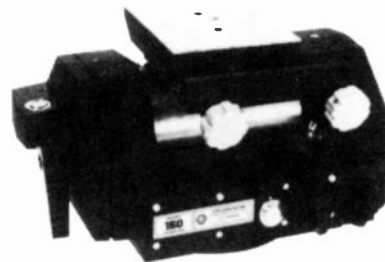

**Model 150—XR** ..... \$4950.00  
Including the following standard accessories.

Standard Handle (5/8" diameter, 15" length)  
Adjustable Balance Quick Release Camera Platform, for  
use with one or two handles (extra handle not included)  
Mitchell Base with tiedown assembly  
1000 Inch-Pound Counterbalance Spring

### Factory Order Options

Add the following amount when substituted for the above  
standard accessories.

Extended Handle for Video (3/4" diameter, 26" length) . . . **70.00**  
1500 Inch-Pound Counterbalance Spring ..... **90.00**

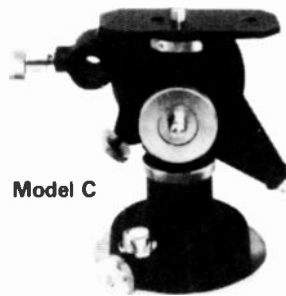

Model C

**Model C** ..... \$795.00

Including the following standard accessories

- Standard Handle ( 1/2" diameter, 10" length)
- Fixed Camera Platform with 3/8"-16 camera tiedown screw
- Pro Jr Base with tiedown assembly
- 50 Inch-Pound Counterbalance Spring

### Factory Order Options

Add the following amount when substituted for the above standard accessories.

- Adjustable Spread Double Handle for Video (2 each 1/2" diameter, 16" length) ..... \$155.00
- Narrow (1" width) Fixed Camera Platform with 1/4"-20 camera tiedown screw ..... 40.00
- Arri 16 Ball Base ..... N/C
- Claw Ball Base with tiedown assembly ..... N/C

### Accessories

#### Handles

- Standard Handle for Models C or 30 (1/2" diameter, 10" length) ..... \$ 65.00
- Adjustable Spread Video Double Handle for Model C (2 each 1/2" diameter, 16" length) ..... 220.00
- Standard Handle for Model 50 (1/2" diameter, 15" length) ..... 75.00
- Standard Handle for Model 100 (5/8" diameter, 15" length) ..... 90.00
- Extended Handle for Video for Models 100 or 150 (3/4" diameter, 16" length) ..... 160.00

#### Camera Mounting Plates

(replacements)

- Lisand Type for Models 30 or 50 ..... \$ 20.00
- Cine 60 Type for Models 30 or 50 ..... 25.00
- O'CONNOR Type for Model 50 ..... 25.00

#### Adapters

(from base of fluid head to top casting of tripod)

- Pro Jr to Arri 16 for Models C, 20, 30 or 50 ..... \$ 85.00
- Pro Jr to Claw Ball for Models C, 20, 30 or 50 ..... 110.00
- Pro Jr to Mitchell for Models 50 or 100 ..... 120.00
- Mitchell to Super Claw Ball for Models 100 or 150 ..... 190.00
- Super Claw Ball to Mitchell for Models 100 or 150 ..... 315.00

#### Tiedown Assemblies

(replacements) for

- Pro Jr Base, or Pro Jr to Arri 16 Adapter ..... \$ 25.00
- Claw Ball Base ..... 40.00
- Pro Jr to Claw Ball Adapter ..... 40.00
- Pro Jr to Mitchell Adapter ..... 30.00
- Pro Jr/Flat Base ..... 25.00
- Arri 35 Ball Base ..... 25.00
- Mitchell Base ..... 30.00
- Pro Jr to Mitchell Adapter ..... 30.00

- Super Claw Ball Base ..... 45.00
- Mitchell to Super Claw Ball Adapter ..... 45.00

### Cases

- Model C ..... \$230.00
- Model 30 ..... 230.00
- Model 50 ..... 245.00
- Model 100 ..... 270.00
- Model 150 ..... 315.00
- Regular Claw Ball Tripod ..... 140.00
- Baby Claw Ball Tripod ..... 130.00
- Standard and Regular Super Claw Ball Tripods ..... 215.00
- Baby Super Claw Ball Tripod ..... 215.00
- Hydro-ped only ..... 415.00
- Hydro-ped with either Model 30 or 50 ..... 435.00

### Bases

(with tiedown assemblies)

- Flat Base for Model 30 ..... \$ 55.00
- Pro Jr Base for Model C ..... 115.00
- Pro Jr Base for Models 30 or 50 ..... 110.00
- Pro Jr/Flat Base for Models 30 or 50 ..... 110.00
- Pro Jr Base for Model 100 ..... 140.00
- Arri 16 Ball Base for Model C ..... 115.00
- Arri 16 Ball Base for Models 30 or 50 ..... 115.00
- Claw Ball Base for Model C ..... 115.00
- Claw Ball Base for Models 30 or 50 ..... 110.00
- Arri 35 Ball Base for Models 30 or 50 ..... 125.00
- Arri 35 Ball Base for Model 100 ..... 140.00
- Mitchell Base for Model 50 ..... 140.00
- Mitchell Base for Model 100 ..... 140.00
- Mitchell Base for Model 150 ..... 140.00
- Super Claw Ball Base for Model 100 ..... 215.00

### Camera Platforms

- Quick Release Camera Platform for Model 30 (with Removable Lisand type Camera Mounting Plate) ..... \$235.00
- Adjustable Balance Quick Release Camera Platform for Model 30 (with removable Cine 60 Type Camera Mounting Plate for use with one or two handles - extra handle not included) ..... 285.00
- Adjustable Balance Quick Release Camera Platform for Model 30 (with removable Lisand Type Camera Mounting Plate, for use with one or two handles - extra handle not included) ..... 285.00
- O'CONNOR Quick Release Camera Platform for Model 50 (with Removable Camera Mounting Plate) ..... 220.00
- Fixed Camera Platform for Model 50 ..... 220.00
- Adjustable Balance Quick Release Camera Platform for Model 50 (with removable Cine 60 Type Camera Mounting Plate, for use with one or two handles - extra handle not included) ..... 285.00
- Adjustable Balance Quick Release Camera Platform for Model 50 (with removable Lisand Type Camera Mounting Plate, for use with one or two handles - extra handle not included) ..... 285.00
- Fixed Camera Platform for Model 100 ..... 250.00
- Adjustable Sidemount Platform for M-100, for use with one or two handles ..... \$625.00
- Adjustable Balance Quick Release Camera Platform, for use with one or two handles for Model 150 (extra handle not included) ..... 625.00



# PROFESSIONAL AUDIO PRODUCTS

## 111B/1 Spring Reverberation (2 Channel)

Dual-channel spring reverb with six springs/channel for smoothness and natural sound. "Floating threshold" limiter attenuates "spring twang" and protects against overload. Shelving bass and quasi-parametric midrange EQ. Unbalance input accepts line-level or semi-pro (medium level) gear. Transformer-balanced main output; unbalance "mixed" output allows use "in-line" without external mixers. Compact, rugged, and reliable. **\$849.00**

## 245E Stereo Synthesizer

Creates a seductive pseudo-stereo effect from mono original. Left and right channels sum back to original mono for total compatibility in disc cutting and FM stereo broadcast. Doesn't affect the frequency balance of the mono original. Easy to use; only three operating controls. Unbalance line-level input and outputs. **\$399.00**

## 418A Stereo Compressor/Limiter

Famous OPTIMOD-FM circuitry adapted for production and recording applications. Exceptionally smooth sound with adjustable program-controlled release time. Separate high frequency limiter with four selectable breakpoints from 25 to 75us. Simple, easy-to-use stereo ganged controls. Accurate stereo tracking. Balanced line-level inputs; unbalanced outputs. Ideal for processing complex program material in cassette duplication, broadcast production, and recording studios. **\$849.00**

## 424 Gated Compressor/Limiter/D-Esser

Production AGC device which achieves high average loudness without undesirable artifacts. Separate Compressor/Limiter and De-Esser control loops, with program-controlled parameters. Defeatable gate with adjustable threshold freeze gain. Adjustable attack-time, release time, and compression ratio. Independent De-Esser similar to the 526A De-Esser. Low distortion Operation. 25 dB gain reduction. Better than 25 dB de-ess gain reduction in addition to 25 dB compressor/limiter gain reduction. True peak-reading output level meter.. True peak-reading gain reduction meter. Selectable linear or exponential release time characteristics. Rugged all metal 19" rack-mount package. Available in mono stereo (channels independent or strappable). Extensive RFI suppression. Balanced inputs and outputs and 115/230V, 50/60 Hz power supply standard. **424A \$899.00**  
**422A (Mono) \$569.00**

## 516EC Dynamic Sibilance Controller (3 Channel)

Three-channel de-esser with unbalance line-level inputs and outputs. Ideal for simultaneous de-essing of several voices in cinema, recording, or broadcast. Easy to adjust with single THRESHOLD control. De-essing constant over 15 dB input range. De-essing defeatable without clicks or pops. Outstandingly quiet and clean. **\$719.00**

## 526A Dynamic Sibilance Controller (1 Channel)

Effective de-essing without audible "action". De-essing constant over 15 dB input level range. Easy to set up and use—only two operating controls (GAIN and THRESHOLD). Fully balanced transformer-coupled input and output with mic/line switching on input. Can be inserted and removed from circuit without clicks or pops. Convenient LED level and de-essing indicators. **\$469.00**

## 622B Parametric Equalizer

A two channel parametric equalizer for use where continuous, non-interacting control over center frequency, bandwidth, and amount of peak boost or cut is desired. Four peaking bands per channel with "constant-Q" curves providing notching capability; individual channel and band in/out switches; GAIN control; overload lamp. Line-level balanced input and unbalanced output. Output can be balanced by addition of optional transformer.

**622A 1 Channel \$509.00**  
**622B 2 Channel \$799.00**

### ACCESSORIES

\*RET-5 Balanced output transformer. Order one per output **\$16.00**

## 672A Mono Graphic Parametric Equalizer

A single channel quasi-parametric equalizer with continuous control over center frequency, bandwidth, and amount of peak or dip. Convenient graphic-style EQ controls provide reciprocal EQ in eight bands. Additional 12 dB/octave highpass and lowpass filters tune continuously over 100:1 frequency range. Additional lowpass output permits use as equalizer cascaded with electronic crossover. GAIN control; overload lamp; IN/OUT switches for equalizer and each filter. Line-level balanced input; unbalance outputs can be balanced with optional transformer(s). **\$629.00**

### ACCESSORIES

\*RET-6 Balanced output transformer. Order one per output **\$16.00**

## 674 Stereo Graphic Parametric Equalizer (with HP/LP Filters, Barrier Strip Terminals)

A two-channel version of the 672A. Controls are configured to facilitate accurate, easy adjustment of both channels simultaneously when equalizing stereophonic program. Each channel identical to the 672A, including all controls and overload indicator, with the exception that the electronic crossover outputs are arranged as "MAIN/LOWPASS" and "HIGHPASS" to provide further protection against accidental tweeter burnout should IN/OUT switches be incorrectly operated. **\$1179.00**

### ACCESSORIES

**ACC-3 Plexiglass security cover for filter section controls \$ 9.00**  
**\*RET-7 Balanced output transformers (2) for main outputs \$32.00**  
**\*RET-8 Balanced output transformers (4) for both outputs \$64.00**  
**\*RET-9 2 ckt phone jacks for inputs and main outputs \$10.00**  
**\*RET-10 2 ckt phone jacks for inputs and all outputs \$13.00**  
**\*RET-11 XLR-type connectors for inputs and main outputs \$24.00**  
**\*RET-12 XLR-type connectors for inputs and all outputs \$30.00**

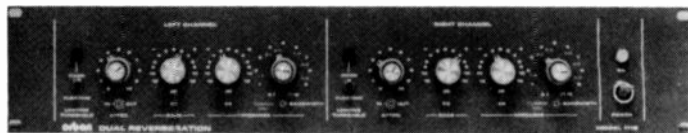

111B/1

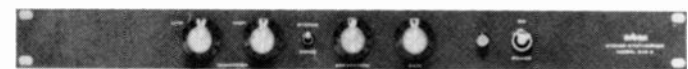

245E

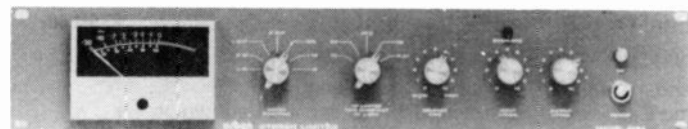

418A



424A



516EC



526A

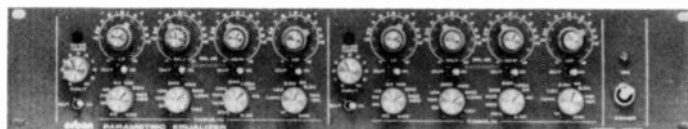

622B



672A

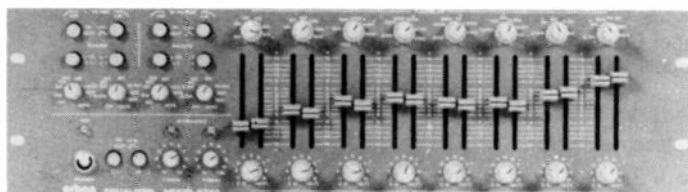

674





**RECAM™ B-100 System Consisting Of In-Camera VTR with AK-100 Camera and AU-100 Recorder, Studio VTR Model AU-300 and Editing Controller Model AU-A30.**

**B-100 IN-CAMERA VTR**

**Self-Contained, Lightweight, and Properly Balanced for One Person Operation**

The VTR (AU-100) and Camera (AK-100) lock together to form the B-100 In-Camera VTR. It is a self-contained unit that lets one person cover the action without the need for connecting cables, shoulder straps or pack frames. The B-100 is lightweight and compact. Weighs less than 22 pounds and is about the same size as an ordinary first generation portable broadcast camera. Its low center of gravity makes it well balanced.

The B-100 gives you a full 20 minutes of recording on one NV-T120HG VHS cassette, and is powered by rechargeable battery (SQ-13F) for 60 minutes of continuous operation.

**Broadcast Quality Picture**

**• New 1/2" M-Format**

The RECAM's professional quality results are made partly possible by a special recording process which records Y and I/Q information on separate video tracks. This means that Y and I/Q signals are delivered directly from the camera to the recorder. In addition, the I/Q signals are multiplexed for even greater freedom from intermodulation. Also contributing to the outstanding picture quality are the 4 video recording heads and the high tape speed of about 8 ips with a recording wavelength of 27,000 cycles per second. Although compact VHS tape is only 1/2" wide, the M-format recording system delivers broadcast quality video, 2 high quality audio tracks, a control track, and a time code track all on this space saving, easily available tape.

**AU-300 Studio VTR**

The RECAM system goes beyond the new B-100 Integrated Camera/VTR. The AU-300 is our state-of-the-art studio VTR for high quality playback and accurate program production. The AU-300 features complete direct drive operation, including head cylinder, capstan, and reel motors. It has head switching in vertical intervals and full dub capability (Y, I/Q). Designed with professional editing in mind, the AU-300 is vertically built for EIA 19" rack mounting or can be placed in just about any location. The front panel opens for access to plug-in circuit boards for easy servicing.

The M-type tape transport is rugged, precise, and extremely smooth. The accurate search dial makes for quick tape point location, and all operation is of the direct control type so that mode changes can be made without having to go to stop.

**Features**

- M-format recording can produce broadcast quality results with the studio VTR AU-300
- Y and I/Q or NTSC video input and output
- Advanced microprocessor control for smooth tape transport and direct mode operation
- Vertical design for EIA rack mounting, easy operation, and easy internal access for servicing
- Insert or assembly editing
- Audio limiter built-in
- Y and I/Q direct dubbing input and output connectors for minimal loss of signal quality
- 4 servo controlled direct-drive motors
- 2 audio tracks plus a time code track
- Dial search control with jogging capability
- Multiple AC power source capability

**AU-A30 Editing Controller**

the RECAM system offers the AU-A30 high performance editing controller to govern the actions of our AU-300 studio VTR. It performs fast and very accurately.

Large search dials make it easy to select edit points on each machine. Digital displays show your selected entry/exit edit points by hours, minutes, seconds, and frames. Jog and search modes provide extra flexibility. Edit mode buttons let you select insert or assembly, and you can select video, audio ch-1 and audio ch-2 independently. Go-to and preview functions add practical convenience to the AU-A30.

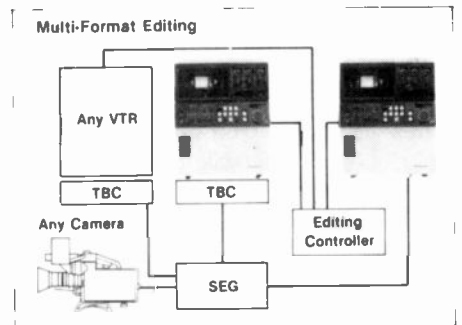

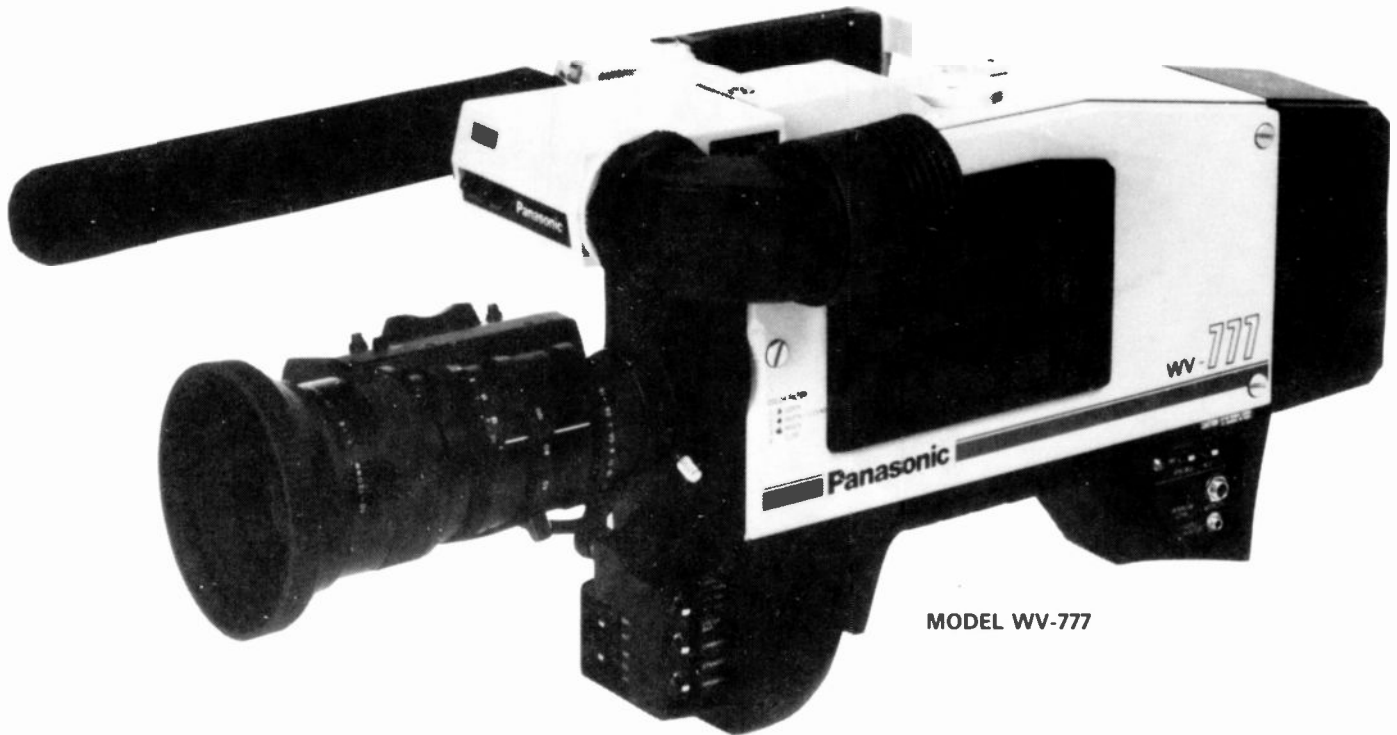

MODEL WV-777

**MODEL WV-777 COLOR VIDEO CAMERA  
WITH THREE TUBE PRISM OPTICS SYSTEM**

Model WV-777 contains three 2/3" SATICON image pick-up tubes and an efficient prism optics system for strikingly crisp and clear pictures, even under low light situations. The camera also offers a full range of high performance operating features.

Model WV-777 is designed for comfortable use, with a low profile that permits unobstructed vision for the user. It is attractively styled and weighs just 11 pounds with its weight evenly distributed to facilitate balancing. The camera is housed in a metal case for extra strength, protection for internal components and freedom from RF interference. Its magnesium die-cast chassis supports the internal components for durability, low weight and proper alignment of the optical system.

Panasonic Model WV-777 incorporates horizontal and vertical image enhancers that produce clear image boundaries and rich image crispness. The camera boasts a signal to noise ratio of 55dB and a horizontal resolution of 550 lines at center. Its automatic beam control reduces blooming and comet tailing and its digital auto-white and auto-black circuits with memory capability speed set-up time.

Model WV-777 consumes only 22 watts with a 1.5" viewfinder, providing extended running time when used with batteries, and operates from three different power sources: body-integrated NiCd battery; body-integrated AC power supply or optional RCU or VTR. It is compatible with

all varieties of VHS systems, through Y, C and NTSC standard signal outputs. It is also studio adaptable with the optional 5" studio viewfinder, studio lens package and remote control unit with cable lengths up to 1000 feet. The Model WV-777 also comes in a studio configuration, WV-777ST, that can be converted to ENG/EFP use.

Among the camera's convenience features are intercom level control, selectable audio gain for flexible microphone selection, built-in full color bar generation and an RS-170A Sync with Genlock for multi-camera set-ups. The unit's viewfinder indicates color conversion warning, low battery, high gain flash, VTR start and stop and a system tally. All operating controls of Model WV-777 are mounted on the side and front of the camera so adjustments can be made without opening the camera's side panel.

Camera model WV-777 is equipped with a 12:1 f/1.4 zoom lens, and Panasonic's 14:1 f/1.4 or 10:1 f/1.4 lenses are offered as optional accessories to the WV-777X version that comes without a lens.

Video camera Model WV-777 provides a +6 and +12 dB high gain selection switch and has a switchable audio output level of -20dB or -70dB. It is Gamma correction adjustable from .45 to 1.0 and provides a stand-by switch for reduced power consumption during idle modes. Full function controls are also provided for R, G, B, horizontal and vertical R and B registration, auto/manual iris, R and B gain pedestal and total pedestal.

**\$7750.00**

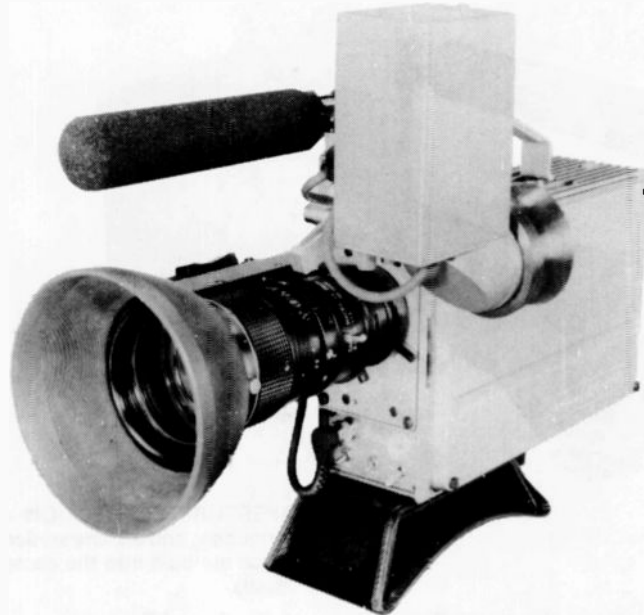

**ENG/EFP PORTABLE COLOR CAMERA**

**AK-710.** New prism picture quality, self-contained ENG/EFP color video camera, the AK-710. This compact and lightweight camera is available with either three Saticon® or Plumbicon® tubes, and a high-index prism optical system with a built-in bias light. There is a horizontal resolution of 500 TV lines at center, and a 52dB signal-to-noise ratio at the standard illumination of 200 FT. Cd at f/3.5. Another outstanding feature is Feedback Beam Control (FBC), which reduces the chances of comet-tailing by stabilizing scene highlights.

**QUALITY ENGINEERING FEATURES:**

**PRISM OPTICAL SYSTEM** — The AK-710 utilizes a high-index, prism optical system. Bias lights are built into the camera for reduced lag. The camera is offered with either three 3/4" Saticon or Plumbicon tubes.

**DIE-CAST CHASSIS** — The AK-710 is protected by a durable die-cast chassis, for rigid alignment of the camera's optical system, allowing the AK-710 to function in demanding portable operations.

**FEEDBACK BEAM CONTROL** — The FBC circuitry greatly reduces comet-tailing, by providing the beam current necessary to stabilize scene highlights exceeding normal white levels. This also extends the dynamic range of the camera, and allows it to retain full resolution without additional noise. The AK-710 uses DBC selectively, so that demands for high beam occur only during the highlight interval, to help lengthen tube life, and preserve edge geometry.

**RS-170A INTERNAL SYNC AND BUILT-IN GENLOCK CIRCUIT** — The AK-710 features an RS-170A internal sync system, and a built-in genlock operation for video system situations. The camera also incorporates adjustable horizontal and vertical blanking intervals.

**ENCODER** — The AK-710 offers a Y I/Q encoder.

**AUTOMATIC WHITE BALANCE** — For color picture stability, the AK-710 utilizes an automatic analog memory white balance circuit. A white set button is positioned on the camera front. The optional RCU also sets the white level automatically. The white balance is also visible in the camera viewfinder.

**BUILT-IN COLOR CONVERSION FILTER** — The camera offers a 4-position color conversion filter, and neutral density filter. 3200° K, 4700°K, 6000°K, and 25% ND filter and closed.

**BUILT-IN COLOR BARS** — There is a front-mounted control for full vertical color bars.

**HIGH GAIN** — The AK-710 functions in low light conditions, via its 2-position high gain switch (+6 dB, 12 dB), which is also front-mounted for fingertip control. A stand-by switch is also positioned there, to further simplify video operations.

**CRT VIEWFINDER** — The camera utilizes a detachable, and position-adjustable 1.5" CRT viewfinder (1-3/8" actual visual size, measured diagonally). The viewfinder has built-in video signal level and battery warning indicators, and a tally light.

**ENG/EFP PORTABLE OPERATION** — The AK-710 performs in a portable ENG/EFP system, along with any Panasonic 3/4" or 1/2" VCR.

**SYSTEM OPERATION** — For portable video situations, the AK-710 connects directly to any portable 3/4" or 1/2" VCR. This system can be powered by either a battery pack, or the NV-B50R AC adaptor.

**STUDIO OPERATION** — The AK-710 connects to the optional remote control unit (RCU) by a multi-pin cable. The RCU offers automatic cable compensation, subcarrier phase and horizontal phase controls, horizontal and vertical R and B centering, an intercom jack and a tally light. A 5" studio CRT viewfinder (4.5" actual visual size, measured diagonally) is optional for complete studio operations.

**\$7850.00**

**OPTIONAL ACCESSORIES — AK-760/EN and AK-710/EN**

<b>J13X9BIE</b>	13X Zoom, auto iris, servo zoom, 9-118mm, f/1.6, 2x extender	<b>\$5,250.00</b>
<b>A12X9BERM</b>	12X Zoom, auto iris, servo zoom, 9-108mm, f/1.72, 2x extender	<b>5,250.00</b>
<b>J10X11IG</b>	10X Zoom, f/1.6 auto iris, servo zoom, 11-110mm	<b>1,700.00</b>
<b>SPBp-2076</b>	Studio conversion kit for J13X9BIE and J10X11IG includes rear manual focus control and rear servo zoom control	<b>1,350.00</b>
<b>FC-A10</b>	Studio conversion kit for A10X11BRM	<b>1,350.00</b>
<b>FC-A12</b>	Studio conversion kit for A12X9BERM	<b>1,350.00</b>
<b>NV-B50R</b>	AC adaptor for AK-760 or AK-710 and NV-9400 portable VCR	<b>475.00</b>
<b>AK-7260</b>	Remote control unit (RCU) for studio operation	<b>1,950.00</b>
<b>AK-7460</b>	4.5" Viewfinder	<b>995.00</b>
<b>22C-50</b>	RCU Cable for camera, 50 ft.	<b>400.00</b>
<b>22C-100</b>	RCU Cable for camera, 100 ft.	<b>600.00</b>
<b>9C-25</b>	VTR Extension Cable for camera, 25 ft.	<b>120.00</b>
<b>9C-50</b>	VTR Extension Cable for camera, 50 ft.	<b>200.00</b>
<b>BP-110</b>	Battery Pack (4 AH) with trickle charger and mounting adaptor	<b>650.00</b>
<b>SQ-13F</b>	Battery unit for BP-110	<b>500.00</b>
<b>PC-410</b>	Carrying Case	<b>330.00</b>
<b>AKY-1033</b>	Tripod Mounting Adaptor	<b>225.00</b>
<b>WM-667</b>	Microphone	<b>225.00</b>

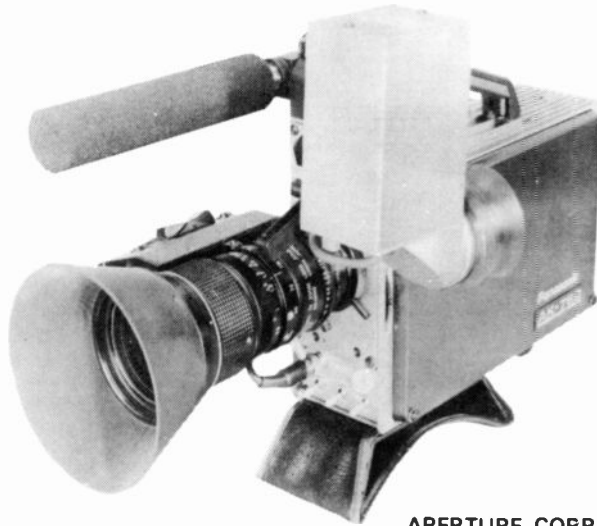

**AK-760.** This self-contained, quality instrument employs three 2/3" newly advanced diode-gun Plumbicon® tubes, and high-index prism optics. These features will ensure the superior performance required for ENG or Studio applications. There is an excellent horizontal resolution of 600 TV lines at center, and a 54 dB signal-to-noise ratio at the standard illumination of 200 Ft. Cd at f/4.0. Another quality feature is Feedback Beam Control (FBC), which reduces the chances of comet-tailing by stabilizing scene highlights. A standard 2-line vertical enhancer circuit is also included, to provide sharp and accurate pictures.

**PERFORMANCE FEATURES:**

**PRECISION OPTICAL SYSTEM** - The AK 760 utilizes a high-index, prism optical system. The camera incorporates three 2/3" diode-gun Plumbicon tubes. Bias lights are built into the camera for reduced lag.

**ADVANTAGES OF THE DIODE-GUN PLUMBICON TUBE SYSTEM OVER CONVENTIONAL PLUMBICON TUBE SYSTEMS** - Higher Resolution: The resolution is enhanced by the use of a thinner photoconductive layer in combination with a new diode-gun. There is an increased modulation depth, without influencing the lag properties of the AK-760. This allows better dynamic resolution and performance under low key conditions. The camera is equally effective in dynamic outdoor scenes, under different ambient temperature conditions. The AK-760 produces excellent static resolution as well. Lower Lag: Lag is minimized in the AK-760. The diode-gun system generates a lower beam resistance, and the process is aided by a built-in bias light. This affords low beam temperature performance even at high beam current, and results in a highly versatile camera suited to ENG, EFP and general studio application.

**FEEDBACK BEAM CONTROL** - The FBC circuitry greatly reduces comet-tailing, by providing the necessary beam current to stabilize scene highlights exceeding normal white levels. This also extends the dynamic range of the camera, and allows it to retain full resolution without additional noise. The AK-760 uses FBC selectively, so that demands for high beam occur only during the highlight interval, to help lengthen tube life, and preserve edge geometry.

**EXCELLENT SENSITIVITY** - The standard illumination of the AK-760 is 200 Ft. Cd at f/4.0, and the minimum illumination is 5 Ft. Cd at f/1.8 with +18 dB high gain. This allows shooting in low light sources without a considerable reduction in the depth of field. The built-in high gain switch (+9 dB, 18 dB) is mounted on the front of the AK-760.

**HIGH RESOLUTION, HIGH SIGNAL-TO-NOISE RATIO** - The AK-760 has an excellent horizontal resolution of 600 TV lines at center, and a 54 dB signal-to-noise ratio, at the standard illumination of 200 Ft. Cd at f/4.0.

**APERTURE CORRECTION** - The AK-760 has horizontal aperture correction, and a 2-line vertical enhancer circuit as standard features. These are built into the camera head to produce clear and accurate visuals.

**Video Signal Features:**

• RS-170A Internal Sync and Built-in Genlock Circuit • Adjustable Blanking • Gamma Range • Encoder • Phase Controls • Test Signals

**Operational Features:**

**ECONOMY OF OPERATION AND MAINTENANCE**

• Built-in Color Conversion Filter • Automatic White Balance • Front Mounted Controls • CRT Viewfinders • Three-Way Power Supply • Lens Mounts • Microphone • Operating Controls • Maintenance Features

**System Features:**

• Self-Contained Portable ENG Operation • Portable VTR Interface • Studio Operation • Chroma Key Generator • Self-Contained EFP Operation

**Additional Studio Options:**

• CRT Viewfinder • Studio Conversion

**\$32,000.00**

**OPTIONAL ACCESSORIES—AK-760/EN and AK-710/EN**

<b>J13X9BIE</b>	13X Zoom, auto iris, servo zoom, 9-118mm, f/1.62x extender . . . . .	<b>\$5,250.00</b>
<b>A12X9BERM</b>	12X Zoom, auto iris, servo zoom, 9-108mm, f/1.72x extender . . . . .	<b>5,250.00</b>
<b>J10X11IG</b>	10x Zoom, f/1.6 auto iris, servo zoom, 11-110mm . . . . .	<b>1,700.00</b>
<b>A10X11BRM</b>	10x Zoom, f/1.6 auto iris, servo zoom, 11-110mm . . . . .	<b>1,700.00</b>
<b>SPB-2076</b>	Studio conversion kit for J13X9BIE and J10X11IG includes rear manual focus control and rear servo zoom control . . . . .	<b>1,350.00</b>
<b>FC-A10</b>	Studio conversion kit for A10X11BRM . . . . .	<b>1,350.00</b>
<b>FC-A12</b>	Studio conversion kit for A12X9BERM . . . . .	<b>1,350.00</b>
<b>NV-B50R</b>	AC adaptor for AK-760 or AK-710 and NV-9400 portable VCR . . . . .	<b>475.00</b>
<b>AK-7260</b>	Remote control unit (RCU) for studio operation . . . . .	<b>1,950.00</b>
<b>AK-7460</b>	4.5" Viewfinder . . . . .	<b>995.00</b>
<b>22C-50</b>	RCU Cable for camera, 50 ft. . . . .	<b>400.00</b>
<b>22C-100</b>	RCU Cable for camera, 100 ft. . . . .	<b>600.00</b>
<b>9C-25</b>	VTR Extension Cable for camera, 25 ft. . . . .	<b>120.00</b>
<b>9C-50</b>	VTR Extension Cable for camera, 50 ft. . . . .	<b>200.00</b>
<b>BP-110</b>	Battery Pack (4 AH) with trickle charger mounting adaptor . . . . .	<b>650.00</b>
	Battery unit for BP-110 . . . . .	<b>500.00</b>
<b>SO-13F</b>	Carrying Case . . . . .	<b>330.00</b>
<b>PC-410</b>	Tripod Mounting Adaptor . . . . .	<b>225.00</b>
<b>AKY-1033</b>		
<b>WM-667</b>	Microphone . . . . .	<b>225.00</b>

**PORTABLE COLOR CAMERAS  
SATICON TUBE**



**WV-3890 Standard  
ENG Configuration**

**C Mount  
Rear Control  
for Power Zooms**

**WV-3990 Standard  
ENG Configuration**

**S Mount  
Servo Zoom**

**Series: WV-3890 and WV-3990**

<b>WV-3890</b>	ENG version "C" Mount	<b>\$2495.00</b>
<b>WV-3990</b>	ENG version "S" Mount	<b>2995.00</b>
<b>WV-3990EN</b>	Studio version	<b>4250.00</b>
<b>WV-3890H</b>	Camera head only	<b>1895.00</b>

Four different color camera models, incorporating high performance (high-band) 3/4" Saticon pick-up tube.

Each listed model except WV-3890H camera head is a complete camera package ready to perform.

In addition with optional accessories the two ENG models (WV-3890/WV-3990) can be converted to studio configuration.

The WV-3890H camera head can be adapted to almost any configuration with optional accessories available except (use with auto-iris 12:1 servo control power zoom lens, requires an S mount).

**Features**

• Improved color and picture quality • Horizontal resolution — 300 lines • Signal to noise ratio — 50 dB • Digital auto white balance • 3 position high gain switch (normal, +6dB, +12dB) • Auto iris zoom lens — WV-3890 (12.5mm to 75mm) f/1.4 auto iris power zoom; WV-3990 (10mm to 120mm) f/1.6 auto iris, power servo control zoom • Minimum illumination — WV-3890 5 footcandle (50 lux) f/1.4 (+12 dB); WV-3990 7.0 footcandle (70 lux) f/1.6 (+12 dB) • Built-in color bar generator • EIA standard RS-170A sync • HV blanking adjustable — H-10.8 μ sec; V-20 H • 4 position color temperature conversion filter wheel — 3200°K, 4500°K, 6000°K, 6000°K with 25% neutral density filter • (FBC) Feedback Beam Control for expanded dynamic range and also limits comet-tailing • 1 H type vertical enhancer • Two audio output level (-20 dB, -72 dB), (internal mounted switch) • VTR trigger polarity change SW. (internal mounted switch) for JVC, portable decks • Maximum cable length — 10 p cable — 60 ft.; 19 p cable — 330 ft. • Weight (9.7 lbs.) — WV-3890 ENG configuration; Weight (13 lbs.) — (WV-3990 ENG configuration) • 1.4" (actual visual size, measured diagonally electronic viewfinder) • Aluminum die-cast construction

**WV-3890 ENG Configuration Consists of:**

• Camera head with handle, (WV-3891) • 1.5" electronic viewfinder • 6:1 auto-iris power zoom lens, (WV-LZ 11/6) • Shoulder pad (WV-Q45) • Microphone (WM-665) • Grip (WV-GR11) • VTR Cable (WVC10x10) • Carrying Case (WV-CC11V)

**WV-3990 ENG Configuration Consists of:**

• Camera head (WV-3991) • 1.5" electronic viewfinder • 12:1 auto-iris power servo zoom lens, (12XSRPZ) • Shoulder pad (WV-Q45) • Microphone (WM-665) • Soft case • Battery case with handle (WV-B10A) • Battery (NR-C-L5J) • VTR Cable (WVC10x10) • Carrying case (WV-CC11U)

**WV-3990EN Studio Configuration Consists of:**

• Camera head (WV-3991) • 5" viewfinder (WV-3805A) • Remote control unit (WV-3806A) • Studio camera cable (19A-25) • 12 X power servo zoom lens (12XSRPZ) • Flexible lens control (WV-LK11)

**ENG Kit WV-KT11 Contains:**

• 1.5" viewfinder • Microphone • Shoulder pad • VTR cable

**Optional Accessories**

<b>WV-CC11/U</b> Carrying Case	<b>\$150.00</b>
<b>WV-LZ11/6</b> 6X Power Focal	<b>350.00</b>
<b>WV-GR11</b> Grip	<b>70.00</b>
<b>WV-KT11</b> ENG Kit 1-1/2" VF Mic VC-10, Shoulder Pad	<b>430.00</b>
<b>WV-3806A</b> Remote CCU	<b>450.00</b>
<b>19A-25</b> Cable Head/CCU	<b>175.00</b>
<b>19A-50</b> Cable Head/CCU	<b>250.00</b>
<b>WV-LK11</b> Studio Lens Conversion Kit	<b>450.00</b>

# Panasonic.

VIDEO SYSTEMS DIVISION

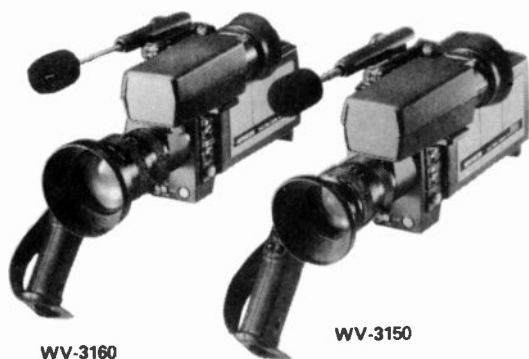

WV-3160

WV-3150



WV-3110



WV-3600



WV-3320

## OMNIVISION II™ VHS™ COLOR CAMERA SYSTEMS

**WV-3110.** Self-contained, compact, portable ENG type color video camera.  $\frac{3}{8}$ " stripe filter integrated vidicon tube. Lens mount is standard C-mount. Built-in 6:1 (12.5 - 75mm) f/1.4 power zoom lens with ALC (Automatic Light Control/Automatic Iris Control) as standard accessory. Automatic and manual (open-close)-iris control. Automatic white balance set. High sensitivity operation with minimum required illumination of only 7 footcandles (70 lux) at f/1.4. Built-in color temperature setting for both indoor and outdoor use. Single Red and Blue gain control for white balance adjustment. Electronic viewfinder, detachable and tiltable for use by either right or left-handed operators. 1.5" (1-3/8" actual visual size, measured diagonally). Vidicon tube protection is provided by automatically closing iris when power is off. Built-in boom microphone. Microphone jack for external microphone. Close-up operation at 4" with macro focusing. Stand-by switch. Signal-to-noise ratio of more than 45 dB. Built-in low light indicator, recording tally lamps, and white balance indicator on viewfinder. Resolution (luminance) of 240 TV lines at center. Video fade-in and fade-out switch for VTR recording. Adjustable handgrip with VCR trigger switch, and zoom lens control. Adjustable handstrap. Aluminum die-cast chassis. Optional power supply/AC adaptor available. **\$1075.00**

**WV-3160/WV-3150.** Self-contained, compact, portable ENG-type color video cameras •  $\frac{3}{8}$ " strip filter integrated NEWVICON® tube • Standard C-mount lens mounts • Built-in zoom lenses with ALC (Automatic Light/Iris Control) as standard accessories. WV-3160: 12:1 (10-120mm) f/2.0 power zoom; WV-3150: 6:1 (12.75mm) f/1.4 power zoom. Both cameras have selectable power zoom speeds • Automatic/manual iris controls • Automatic white balance set • Highly sensitive operation with minimum required illumination of only 7 footcandles at f/2.0 for WV-3160, and just 4 footcandles at f/1.4 for WV-3150 • Built-in color temperature setting for both indoor and outdoor use • Single red and blue gain control for color adjustments • Automatic Gain Control (AGC) on-off switch • 1.5" electronic viewfinder, detachable and tiltable for use by either right or left-handed operators (1.3/8" actual visual size, measured diagonally).

WV-3160 **\$1396.00**  
WV-3150 **\$1575.00**

**WV-3600.** Portable Color Camera System. One 1" Vidicon tube, self-contained portable color camera. Hard shell with die-cast chassis. 6:1 (16-100mm f/2) manual zoom lens with auto/manual iris. Macro operation. 1.5" viewfinder, CRT doubles as monochrome playback monitor. Light intensity indicators and tally light located in viewfinder. Front mounted microphone. 4-position color conversion filter wheel. S/N ratio of 45dB at recommended illumination of 140 foot candles at f/4. Horizontal resolution 250 lines. AGC (automatic gain control). Stand-by switch. System operation with Studio accessories. **\$2295.00**

**WV-3601.** Self-contained camera head of WV-3600 configuration without viewfinder, lens and microphone. **\$1450.00**

**WV-3320.** Portable Color Camera System. Single 1" Vidicon tube. Built-in 6:1 (17-102mm f/2) manual zoom lens with auto/manual iris. 1-3/8" CRT viewfinder mounted on top of camera. CRT doubles as monochrome playback monitor. Light intensity indicators and tally light located in viewfinder. Built-in electret condenser microphone. CCU features 4-position electronic color temperature conversion switch. Manually adjustable red (R) and blue (B) level on CCU. Camera has start/stop trigger switch built into camera handgrip to control VCR. S/N ratio 45dB at recommended illumination of 140 foot candles at f/4. Horizontal resolution 250 lines at center. 15.0 lbs. **\$1345.00**

## ACCESSORIES— COLOR CAMERAS

PC-327. Hard shell carrying case. Use with WV-3000, WV-3110, WV-3150, WV-3160 **\$145.00**

PC-350. Storage case. Use with WV-3320. 13.0 lbs. **\$85.00**

PC-365. Hard shell carrying case. Use with WV-3320. **\$145.00**

WV-3203. Power supply/AC adaptor. Use with WV-3000, WV-3110, WV-3150, WV-3160. **\$50.00**

PC-320. Soft carrying case. Use with WV-3200, WV-3210. 8.0 lbs. **\$75.00**

VP-10. Tripod. Use with WV-3200, WV-3210, WV-3320. 3.5 lbs. **\$50.00**

10H-25A. Camera/VTR extension cable (25 ft.). Use with WV-3200, WV-3210, WV-3600. 2.5 lbs. **\$70.00**

10H-50A. Camera/VTR extension cable (50 ft.). Use with WV-3200, WV-3210, WV-3600. 5.6 lbs. **\$110.00**

4K-30. Camera extension cable (30 ft.). Use with WV-3320. 2.0 lbs. **\$55.00**

WV-3303. AC adaptor. Use with WV-3320. 3.5 lbs. **\$70.00**

WV-KT10. ENG Kit. Use with WV-3601. **\$600.00**

CV6XIG. Auto iris zoom lens. Use with WV-3601. **\$350.00**

WV-Q40. Shoulder Pad. Use with WV-3600. 1.3 lbs. **\$65.00**

DE1232. Battery Charger. Use with NR-C-L5J. 1.8 lbs. **\$49.95**

NV-B51. AC Adaptor. Use with WV-3600, WV-3601. 8.0 lbs. **\$135.00**

NR-C-L5J. Ni-Cd Battery Pack. Use with WV-3600, WV-3601. 2.2 lbs. **\$75.00**

WV-B10. Battery Case. Use with WV-3600, WV-3601. 1.2 lbs. **\$75.00**

4C-10. Camera-AC Adaptor (NV-B51) Junction Cable (10 ft.). Use with WV-3600, WV-3601. 1.2 lbs. **\$30.00**

PC-380. Storage Case. Use with WV-3600. 28.0 lbs. **\$225.00**

WV-Q30. Shoulder pad. Use with WV-3320. 2.5 lbs. **\$65.00**

KF-40F125. Wide angle lens (12.5 mm f/1.4). Use with WV-3320, WV-3601. 0.5 lbs. **\$210.00**

WV-3808. Remote control unit. Use with WV-3600, WV-3601. **\$450.00**

PC-390. Hard Shell Carrying Case. Use with WV-3600. **\$180.00**

WV-3805. 5" Studio Viewfinder. Use with WV-3600, WV-3601. 9.0 lbs. **\$400.00**

MC-60-1. Rear Control 6:1 Zoom Lens (17.0-102mm, f/2). Use with WV-3600, WV-3601. 6.6 lbs. **\$950.00**



WV-1400/1404



WV-1450/1454  
Shown with optional  
Auto Iris Lens

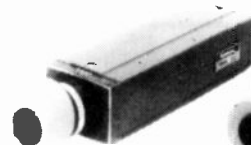

WV-1910

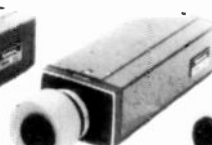

WV-1914

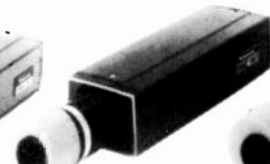

WV-1900

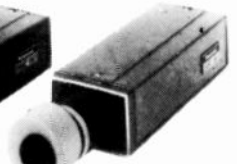

WV-1904



WV-1500/1504



WV-1550/1554  
Shown with optional  
Auto Iris Lens



WV-1800



WV-1804

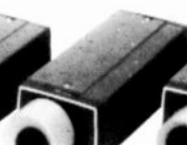

WV-1950



WV-1854

WV-1400/WV-1404 (2/3" Vidicon)  
WV-1450/WV-1454 (2/3" Newvicon)

WV-1500/WV-1504 (2/3" Vidicon)  
WV-1550/WV-1554 (2/3" Newvicon)

Eight new black and white CCTV cameras, the 1400 series are general purpose surveillance models, while the 1500 series are hi performance units.

The WV-1400 series includes two 2/3" M-M Vidicon models and two 2/3" M-M Newvicon models. The WV-1500 series has two 2/3" compound focus separate mesh (S-M) Vidicons models and two 2/3" compound focus separate mesh (S-M) Newvicon models.

#### New Key Features (WV-1400/1404 and WV-1450/1454)

- Sensitivity: WV-1400/1404 0.5 footcandle (5 lux) at F/1.4
- Sensitivity: WV-1450/1454 0.3 footcandle (3 lux) at F/1.4
- Synchronization: line locked random or/internal 2:1 RS-170 internally switchable.
- Horizontal resolution 550 lines.
- Signal to noise ratio 43 dB
- Automatic beam (ABC), auto focus (AFC), control
- Internal beam, focus, and target controls
- Internal 2:1/LL (line locked) sync switch
- (ALC) auto light control (WV-1400/1404)
- BNC connectors
- 1/4" x 20 tapped mounting holes, top and bottom
- New metal case design, (rugged construction for less RFI)

#### VIDICON CCTV CAMERAS-BLACK AND WHITE

WV-1400	.....	\$270.00
WV-1404	.....	270.00
WV-1400X	.....	250.00
WV-1404X	.....	250.00
WV-1500	.....	370.00
WV-1504	.....	370.00
WV-1500X	.....	350.00
WV-1504X	.....	350.00

#### NEWVICON CCTV CAMERAS-BLACK AND WHITE

WV-1450	.....	\$735.00
WV-1454	.....	735.00
WV-1550	.....	850.00
WV-1554	.....	850.00

#### Vidicon Models

WV-1800. 120 Volts AC	.....	\$875.00
WV-1804. 24 Volts AC	.....	875.00

#### Extended Red Newvicon Models

WV-1850. 120 Volts AC	.....	\$1575.00
WV-1854. 24 Volts AC	.....	1575.00

#### WV-1900 Series Ultra Low Light Level Cameras

The four WV-1900 series cameras feature 1-inch separate mesh Newvicon tubes with fiber optics and an Image Intensifier unit, offering stable, high quality video pictures under extremely low light levels with much lower blooming effects of standard Silicon Intensifier Tube cameras.

Newvicon tubes produce burn-in free pictures in a wide range of applications. White clipper circuitry keeps highlights within preset levels, avoiding overdriving the monitor or VTR while Automatic Black Clamp circuits minimize excessive contrasts with sharply detailed images. The signal-to-noise ratio is more than 45 dB for the entire series.

#### Lunar Lite Models

**WV-1900.** Horizontal Resolution is 600 lines at center. 120 Volt AC operation. Automatic light compensation is 1:10<sup>7</sup> with recommended auto iris lens. **\$6,400.00**

**WV-1904.** Horizontal Resolution is 600 lines at center. 24 Volt AC operation. Automatic light compensation is 1:10<sup>7</sup> with recommended auto iris lens. **\$6,400.00**

#### Stellar Lite Models

**WV-1910.** Horizontal Resolution is 500 lines at center. 120 Volt AC operation. Automatic light compensation is 1:2 x 10<sup>9</sup> with recommended auto iris lens. **\$12,500.00**

**WV-1914.** Horizontal Resolution is 500 lines at center. 24 Volt AC operation. Automatic light compensation is 1:2 x 10<sup>9</sup> with recommended auto iris lens. **\$12,500.00**

#### 1800/1850 Series High Resolution Cameras

The 1800/1850 series of black and white high resolution closed circuit television cameras is designed for various critical applications. The WV-1800/1850 series cameras can be used for such diverse applications as broadcast CCTV operations, CATV film chains, TV microscopy and other medical research, educational and instrumentation purposes, and security surveillance.

The four cameras in the series feature EIA standard RS-170 sync with LSI circuitry, a full range of automatic control circuits to assure stable, adjustment-free quality pictures, genlock capability through composite sync or a composite video signal, Auto-Black/AGC circuits for sharp focus pictures in poor contrast situations, automatic switching of internal/external sync modes, and separate protection circuitry preventing tube damage. In addition, models with the Extended Red Newvicon tube are usable in a super-low light environment. All cameras in the series are built into a heavy duty die-cast chassis designed to prevent handling damage and prevent electrical interference.

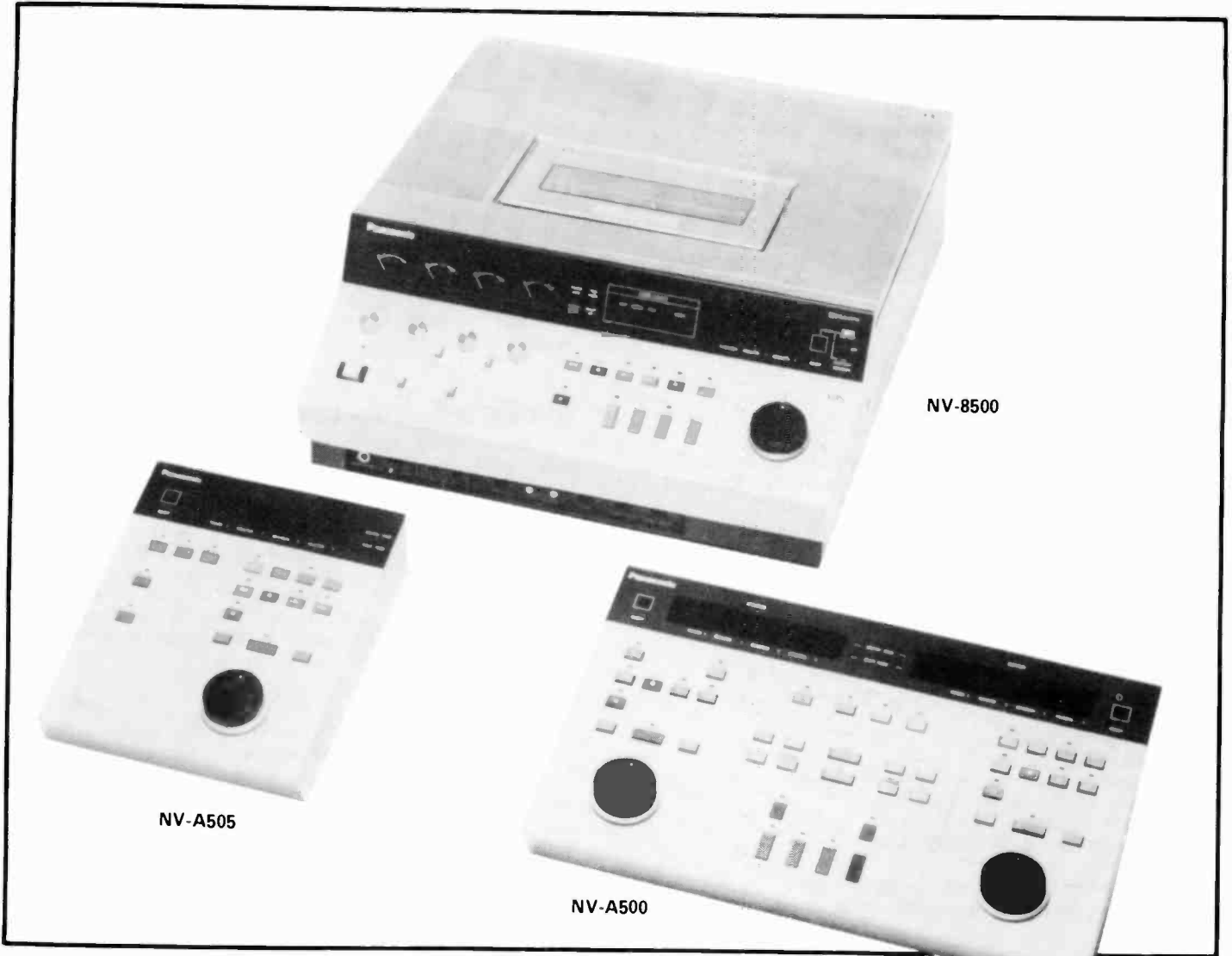

**NV-8500 VHS Editing System**

The Panasonic VHS video editing system provides full video capability for users of the VHS format.

The system features microcomputer-aided editing with such functions as have mainly been available in 3/4" and 1" editing systems.

The Panasonic system consists of video editing recorders (NV-8500) and an editing controller (NV-A500).

**NV-8500** (need two)  
**NV-A500**  
**NV-A505**

**\$3250.00**  
**1500.00**  
**750.00**

- Easy frame-searching at variable speed from 1/25 to 10 times normal speed (both in forward and reverse)
- Flying erase head for frame-by-frame editing
- Editing point presetting and automatic editing point positioning functions
- Both assembly-mode and insert-mode editing functions with an accuracy of +/-2 frame deviation
- 2-ch audio for stereo sound recording and bilingual narration
- Stable and accurate tape running mechanism by DD (Direct Drive) motor
- Field-still function for editing point searching
- AC multi-power sources





NV-A960

**NV-A960 Editing Controller**

Micro-processor-based logic control. Sequential speed search dials for tape searching on both the source and editing decks. Search in FWD and REV and 1/20X, 1/5X, 1X, 2X, 5X speeds plus PAUSE (with still picture). Dial pull lock to selected tape speed; push to automatically return to pause. Two LED Address Time/Lap Time indicators display tape positions in hrs./min./sec./frame. Tape search memory is available for the specific entry and exit point selected for an individual edit-anywhere on the tape. Editing mode selection is made from the editing controller. PREVIEW mode allows rehearsal of an edit prior to the actual editing procedure. REVIEW MODE. A GO TO button sends the editor to the exit point of the last previously performed edit. May be used with multiple voltages: 100V/120V/220V/240V AC, either 60 Hz or 50 Hz. Use with NV-8200, NV-8170, NV-9240, NV-9600, NV-9200A, NV-9500A. 40.7 lbs. Weight: 31.9 lbs. Dimensions: 17-1/8" x 9-1/4" x 17" (WHD)

NV-A960 Editing Controller

**\$2995.00**

**NV-A970 SMPTE Time Code Editing Controller**

Model NV-A970 is equipped with microprocessor based logic control to allow insert and assembly editing on Panasonic 3/4" B2 and G2 models AU-700, NV-9600, NV-9240, NV-9500A and NV-9200A and also permits 1/2" VHS assembly editing using Panasonic models NV-8170 and NV-8200.

100V/120V/220V/240V AC, at either 50 Hz or 60 Hz. With 3/4" Panasonic B2 (AU-700) and G2 (NV-9240/9600) equipment, editing accuracy is +/- 2 frames. Weight (Approximately): 31.9 lbs. Dimensions (Approximately): 17-1/8" W x 9-1/4" H x 17" D.

NV-A970 Time Code Editing Controller

**\$5250.00**



NV-A970

**NV-9600 High Performance 3/4" Videocassette Editing Recorder**

46 dB color, 50 dB monochrome; horizontal resolution of 260 lines of color, 330 lines monochrome. Direct drive video head cylinder and a direct drive capstan servo for maintaining precise head-to-tape speed. Video switching during vertical interval. Microprocessor-based system control: governs the non-locking pushbutton controls; allows direct mode changes without passing through the STOP mode; and permits use with optional Panasonic editing controllers NV-A960 and NV-A950. New DUB IN and DUB OUT connectors. Electronic digital tape counter counts control pulses (CTL) and provide LED readout in minutes and seconds. Indicator lamps are provided for servo lock, frame lock, stand-by and time code use. Flying erase heads help ensure the quality of edits performed. Insert edit cut-in cut-out. Assemble edit: in and out without push stop button. A frame servo on/off switch and horizontal phase adjustment. Audio track 1 can be used either for audio or as a time code track (switchable). Deck includes 6 DC motors and provides beltless tape drive system. Die-cast aluminum chassis. External sync/subcarrier inputs and FM output for use with a time base corrector (TBC). Voltage selector can be switched to 100V/120V/220V/240V AC and the deck can operate on either 60 Hz or 50 Hz. Supplied dubbing cable 6.6 ft. 90.2 lbs. Separate editing of audio CH1, audio CH2 and video. Audio channel 1 may be used for time code information. Weight: 77 lbs. Dimensions: 26-1/8" x 18-3/4" x 9-3/8" (WHD)

NV-9600 3/4" Videocassette Editing Recorder

**\$6950.00**

Standard Accessories: AC power cord, 6-6A. dubbing cable, Dust cover for NV-9240, NV-9600



NV-9600

**NV-9240 High Performance 3/4" Videocassette Recorder**

Two audio channels. Elevator tape loading system. Auto rewind at end of tape. Auto repeat playback mode. Auto search mode stops fast forward or rewind when tape counter reads zero. Non-locking pushbutton controls. Still framing with still frame adjustment. Remote control operation with optional NV-A152. Viewing on conventional TV with optional RF modulator, NV-U134, Ch. 3 or 4 switchable. Dropout/noise compensator. 76.0 lbs. Color and Black and White. S/N 47 dB NV-9240 uses a direct-drive video head cylinder and direct-drive capstan servo for high stability. Pushbutton operations and direct mode changes provided by microprocessor. Audio CH1 can accept time code information. Video head switching is performed in the vertical interval. Four-digit LED tape counter. Dubbing connectors. Produces high resolution of 330 lines monochrome, 240 color. FM output for DOC/TBC. Works on multiple voltages: 100V/120V/220V/240V AC, 60 or 50 Hz. Weight: 90.2 lbs.

NV-9240 3/4" Videocassette Recorder

**\$4500.00**

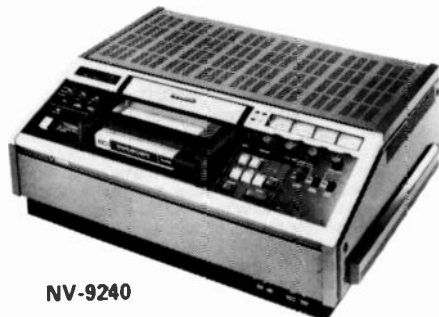

NV-9240

**COMPONENTS EDITING SYSTEMS**

Deluxe 3/4" Editing Systems: NV-9600 (2 units), NV-A960. Panasonic introduces a system package providing the ultimate in advanced-feature editing. The system includes two NV-9600 3/4" high performance editing recorders and one NV-A960 editing controller combined in a total system package. 221 lbs. (3 ctn. total). **\$16,895.00**

High Performance 3/4" Editing System: NV-9600, NV-9240 and NV-A960. A practical approach to the many demands of modern-day video production and editing. A single package of exceptional Panasonic 3/4" equipment designed for precision results throughout the use of one NV-9240 production recorder as source, one NV-9600 3/4" high performance editing recorder and one NV-A960 editing controller. 221 lbs. (3 ctn. total) **\$14,445.00**

# Panasonic

VIDEO SYSTEMS DIVISION



AU-700

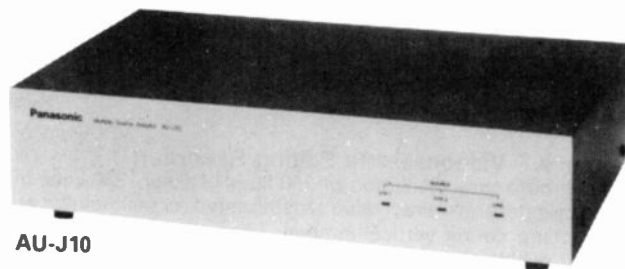

AU-J10



AU-A70

## PROFESSIONAL 3/4" VCR EDITING SYSTEM

Panasonic proudly presents our most sophisticated 3/4" video cassette editing system ever: Direct Drive Editing Recorder AU-700 and Programmable Editing Controller AU-A70. Performing high quality insert and assembly edits, the AU-700 features a die-cast chassis, direct drive video head cylinder and a direct drive capstan servo. This deck also incorporates a separate time code track, XLR audio connectors and microprocessor-based system control. Controller AU-A70 can be programmed to govern up to 20 separate edits, automatically. Once programmed, these

edits are performed without the need for an operator in attendance. And when used with multiple source adaptor AU-J10, the AU-A70 can accept two source player inputs and a line input. For convenience and versatility, the AU-A70 can be used with Panasonic 3/4" decks NV-9600, NV-9240, NV-9500A, NV-9200A, and 1/2" VHS decks NV-8200 and NV-8170. Both the AU-700 and AU-A70 are compatible with various line voltages: 100V/120V/220V/240V AC, 60 Hz or 50 Hz.

### AU-700 Editing Recorder

- High quality video performance: signal-to-noise ratio of 46 dB color, 50 dB monochrome; horizontal resolution of 260 lines color, 330 lines monochrome.
- Direct drive video head cylinder for high stability and a direct drive capstan servo for maintaining precise head-to-tape speed.
- Microprocessor-based system control: governs the non-locking pushbutton controls; allows direct mode changes without passing through the STOP mode; and permits use with Panasonic editing controllers AU-A70 and NV-A960.
- XLR audio connectors. • Audio input level selector. Select line high/low (+4dB, -20dB) and mic (-70dB).
- New DUB IN and DUB OUT connectors (separate Y/C signals) enhance the quality of multi-generation dubs.
- Special APC circuitry automatically switches OFF during Video-to-Video edits or duplication.
- Video frequency response adjustment is provided for normalizing the playback picture.
- Video head switching has been moved to the vertical interval removing it from the picture area.
- Two BNC video outputs and 8-pin monitor connectors.
- Separate time code track. • Audio track 1 can be used either for audio or as a time code track (switchable).
- Electronic digital tape counter counts pulses (CTL) and provides LED readout in minutes and seconds.
- Indicator lamps are provided for servo lock, frame lock, stand-by and time code use.
- AUTO-OFF indicator flashes to show tape slack, or stays on steady to indicate dew problems.
- A flying erase head helps ensure the quality of edits performed.
- Includes frame servo and horizontal phase adjustment.
- Individual editing selection switches for insert

- and assembly edits. • Single field advance when used with AU-A70.
- A recessed front panel features controls for frequency response, chroma level, video mode selection, horizontal phase adjustment and frame servo ON/OFF.
- Deck includes 6 DC motors and provides beltless tape drive system. Motors are: direct drive video head cylinder motor, direct drive capstan motor, reel drive motor, skew motor, loading motor and elevator motor.
- Die-cast aluminum chassis for strength and stability.
- External sync/subcarrier inputs and FM output for use with a time base corrector (TBC).
- Loop-through video input connectors with 75 ohm termination switch.
- Elevator tape loading system.
- An hour meter for monitoring operating hours. Reads up to 1000 hours.
- Works on multiple voltages: 100V/120V/220V/240V AC, 60 Hz or 50 Hz.
- Optional remote controllers NV-A152 and NV-A810.
- Optional Auto-Search Controller NV-A800. \$9250.00

### AU-Programmable Editing Controller

- Microprocessor-based logic control allows use with 3/4" models AU-700, NV-9600, NV-9240, NV-9500A, NV-9200A and 1/2" VHS models NV-8200 and NV-8170.
- Sequential speed search dials for tape searching on both the source and editing decks. Search in FWD and REV at 1/20X, 1/5X, 1X, 2X, 5X speeds, plus PAUSE (with still picture).
- Single field advance when used with AU-700.
- CTL pulse or SMPTE time code editing control.
- Program up to 20 separate edits at one time.
- Includes built-in SMPTE time code generator and reader.
- Two Address Time/Lap Time indicators display tape positions in hrs/min/

- sec/frames including IN time, OUT time and RESET button.
- Edit number indicator.
- Entry and exit points reached by tape search or by specific address points via 10-key board.
- Editing Frame Shift.
- Individual SMPTE time code IN/OUT terminals.
- Programmable editing and tape search functions include: program check; program exchange; insert programming; and an overflow indicator.
- Accepts two source recorder connections when used with multiple source adaptor AU-J10. Also accepts audio/video line inputs when used with AU-J10.
- Permits parallel (A + B) roll (playback) of two source VTR's when used with AU-J10.
- PREVIEW mode allows rehearsal of an edit prior to the actual editing procedure.
- A RETURN button sends both the source and editing decks to the proper entry point.
- A REVIEW mode allows you to quickly check an edit by having the editing deck "run" the edited portion.
- A GO TO button sends the editor to the exit point of the last previously performed edit.
- To keep from processing an incorrectly programmed edit, the AU-A70 will not perform unless the proper information is entered. Error codes pinpoint any procedural errors.
- Entry and exit points of a specific edit may be reset independently.
- May be used with multiple voltages: 100V/120V/220V/240V AC, either 60 Hz or 50 Hz. \$6500.00

### AU-J10 Multi Source Adaptor

The AU-J10 interfaces the signal logic of one or two source players or line inputs to the editing recorder. All units are compatible with 100, 120, 220, 240 VAC, 60/50Hz power line voltages. \$750.00



NV-8350



NV-8110



NV-8C50

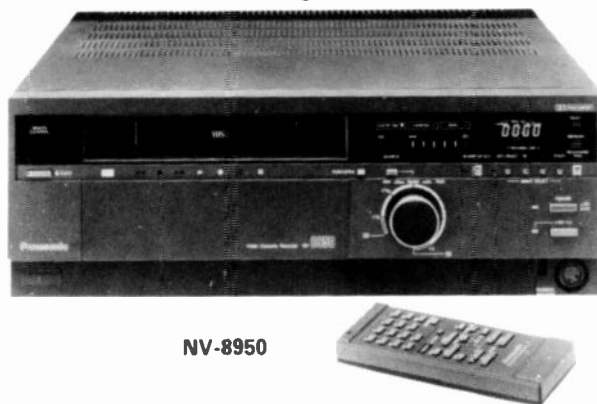

NV-8950

**NV8110**

- Two hours playback time on NV-T120 cassette; 60 minutes (NV-T60) and 30 minutes (NV-T30) cassette are also available.
- Timer-controlled playback capability.
- Variable playback mode: still-frame, frame advance, double-speed and variable speed (1/5-1.5) playback.
- Auto rewind and auto repeat. (For repeating playback automatically)
- Remote controlled capability; still-frame and frame advance playback can be activated from a distance.
- Playback through any conventional TV set.
- May be used with multiple voltages: 110V/120V/220/240V AC.

- Weight: 32.1 lbs. (14.5 kg)
- Dimensions: 19-1/8"(W) x 15-13/16"(H) x 7-5/16"(D) 485(W) x 402(H) x 178 (D)mm
- Accessories Supplied: 1 pc. 300 ohm-75 ohm transformer, 1 pc. VHF matching box 75ohm-300ohm transformer, 1 pc. coaxial cable with one touch type F connector
- Optional Accessories: 1/2" Video Cassette Tape: NV-T120; Approx. 810 ft. (247m) 120 min., NV-T60; Approx. 417 ft. (127m) 60 min., NV-T30; Approx. 210 ft. (64m) 30 min.

**\$850.00**

**NV8350**

- Two hours playback time on NV-T120.
- Two audio channels, for stereo sound, bilingual applications, or audio dubbing. Dual audio meters for accurate level control.
- Dolby Noise Reduction System significantly reduces tape hiss, increases the dynamic range of the audio signal and improves S/N ratio to 45 dB.
- Convenient high speed (9X) search in forward or reverse makes it easy to find desired scenes on the tape while looking at the picture.
- Clear, sharp still pictures of crucial scenes can be viewed slowly and thoroughly by means of the Pause/Still playback.
- Frame Advance Playback makes it possible to view and analyze scenes one frame at a time.
- Standard wired Remote Controller governs: Record, Play, Stop, Rewind, FF, pause, Frame Advance, Slow (1/30-1/5), Cue/Review Channel Selection
- Four video heads for high performance.
- Noise free slow motion at 1/30 — 1/5X speed.
- Quick movements can be observed slowly at any desired speed (1/5-1/30) thanks to the Variable Slow Playback.

- Instant Recording makes it possible to insert new scenes onto tapes that have already been recorded. Later, using the after record function, sound can be inserted to make for nice editing
- 14-day/4 programmable timer with built-in timer back-up.
- One Touch Timer Recording allows automatic recording for 30 min., 60 min., 90 min., and 120 min.
- The Picture Quality Control Adjustment can be adjusted to make the picture either sharp or soft.
- Dimensions: 18-15/16" (W) x 5-3/8"(H) x 14-3/8"(D), 480(W) 136(H) x 364 (D)mm
- Weight: Approx. 24.9 lbs. (11.3 kg)

**\$1500.00**

**NV-8050 Time Lapse Recorder**

1/2" videocassette time lapse recorder/player capable of storing up to 240 hours of program material. The unit, Model NV-8050, employs 1/2" videocassettes and can record color or black and white signals in any of 6 different time lapse modes as well as real time.

Boasting high picture quality—horizontal resolution is 300 lines B/W, 240 lines color—the unit is ideally suited for use as a television broadcast log, recorder for security applications, use in animal behavior studies or for time lapse recording where still photography was previously employed. Model NV-8050 will record for 2 hours real time and is switchable for 12 hours, 24 hours, 72 hours, 120 hours, 240 hours or 1 shot modes. Signal-to-noise ratio is 45 dB.

**\$2795.00**

**NV-8950 Motion Analyzer-Recorder/Playback**

- Two hour/Six hour Recording on NV-T120
- Clear images, without "bar noise" during the speed-search modes (forward and reverse), variable playback speeds, reverse-slow speed, etc. for added viewing convenience and pleasure
- Includes audio switchover function for multiplex recording/playback of stereo or bi-lingual
- Infrared-ray wireless remote-control unit for full control of 14 modes
- Quick program selection feature for extra convenience
- Convenient indicator tells you at a glance how much tape is left
- Special detector senses where recorded part of tape ends and unrecorded part begins
- Front loading for extra convenience. Especially useful for rack mounting or in bookshelf with little overhead clearance
- Electronic-display type of tape counter for superb precision
- Automatic rewind of tape when it reaches the end
- Dolby NR system for reduction of audio noise
- Includes camera connector for direct connection of video camera

**\$1995.00**

**OMNIVISION II VHS  
VIDEOCASSETTE SYSTEM**



NV-8420



NV-8170



NV-8200



NV-A850

**NV-8170.** 2 Hr. 1/2" Video Cassette Player. Color or black and white playback of 1/2" VHS cassettes. Solenoid operated. Compatible with all other VHS systems. Designed for use as source player with the optional Panasonic NV-A820 interface adaptor and optional NV-A950 or NV-A960 Automatic Editing Controller. Random numerical access with optional Auto Search Controller. Feather touch non-locking pushbuttons. Two audio tracks for stereo or bilingual operation. S/N ratio of 45 dB, Horizontal resolution: 300 lines black and white, 240 lines color. Dropout/noise compensator. Annealed aluminum die-cast chassis. Direct drive video head cylinder (DDC). Capstan servo system. Unit can be used with either 60 or 50 Hz. PAUSE/STILL mode. Automatic still frame compensation (ASC). Frame advance button. Variable speed playback from 0.2-1.5x normal speed. Double speed playback. Built-in RF modulator. Optional timer for unattended playback. BNC and 8-pin connectors for video output; RCA and 8-pin connectors for audio output. Tracking control. Dew detector. Front headphone jack. Damped eject mechanism. 41.0 lbs. **\$1250.00**

**NV-8200.** 2 Hr. 1/2" Video Cassette Recorder/Player. Color or black and white recording and playback of 1/2" VHS cassettes. Solenoid operated. Compatible with all other VHS systems. Designed for use as assemble recorder or source player with the optional Panasonic NV-A960 Automatic Editing Controller. Random numerical access with optional Auto-Search Controller. Feather touch non-locking pushbuttons. Two audio tracks. Full remote control capability with optional remote control unit. Automatic functions: Auto Rewind, Auto Repeat. S/N ratio of 45 dB. Horizontal resolution: 300 lines black and white, 240 lines color. Dropout/noise compensator. Annealed aluminum die-cast chassis. Direct drive video head cylinder (DDC). Capstan servo system. Automatic still frame compensation (ASC). Frame advance. Variable speed playback from 0.2-1.5x. Double speed playback. Optional timer for unattended recording or playback. Keyed automatic gain control (AGC) for video. Manual gain control with level meters or limiter for audio. BNC and 8-pin connectors for video; RCA and 8-pin connectors for Audio. Built in RF modulator. Unswitched AC outlet. Built-in handle. UL listed for commercial use. Unit can be used with either 60 or 50 Hz. 42.0 lbs. **\$1550.00**

**NV-8420.** In performance and lightweight portability, Panasonic's new NV-8420 is a sure video winner. In fact, the NV-8420 is today's lightest 1/2" VCR, thanks to weight reduction in all areas including the battery. Nevertheless, you get two full hours of continuous recording time with a single battery pack. This remarkably portable deck is compatible with most Panasonic cameras, and recording can be controlled from the camera itself. An anti-rolling mechanism adds to operational stability when shooting on the move. "Fine editing" makes smooth connections between shots.

Playback convenience is another major attraction of the NV-8420. 12-function remote control is standard equipment, and the soft-touch operations are of the fast, microprocessor-controlled type. Speed-search, still-frame, frame-advance, and variable-slow modes give this deck the flexibility of larger conventional VCR's. **Price on Request**

**NV-A850.** The automatic search controller permits the dividing of a recorded video tape into random program segments for automatic search and playback. With the built-in microprocessor, up to 64 tape segments can be memorized by this controller, and their position data can be recorded on the VHS video cassette tape at the beginning of the tape, for later reference. The search controller is also equipped with push buttons for the remote-controlled operations of the tape transport functions of the connected video tape recorder. The NV-A-850 is designed for use with the VHS-format VTR models NV-8200 and NV-8170 or the 3/4" VTR models NV-9240 and NV-9600. **\$420.00**

**ACCESSORIES —  
NV-8170/NV-8200**

**NV-A800.** Auto Search Controller. Address a number and by numerical access it will search and locate forward or backward any segment on a 2 hour VHS cassette tape; with 6 foot connection cable. 3.0 lbs. **\$350.00**

**NV-A810.** Remote Controller. For remote operation of deck, controlling all major operating functions: PLAY, REWIND, FAST FORWARD, STOP, PAUSE/STILL, SLOW/FAST, FRAME ADVANCE, 2X speed. RECORD and AUDIO DUB on NV-8200 only. Non-locking pushbuttons; with a 10 foot connection cable. 2.2 lbs. **\$125.00**

**NV-A820.** Editing Interface Adaptor. Used between the optional Panasonic NV-A950 Editing Controller and the NV-8200/8170 as source player in combination with 3/4" NV-9500A/NV-9600 editor. Two NV-A820 required in a 1/2" VHS to 1/2" VHS system. 8.0 lbs. **\$550.00**

**NV-C80.** Extension Cable. To extend distance between the deck and either remote controller or auto search controller (16.4 foot length). Up to three NV-C80's may be used. For NV-A800. 2.2 lbs. **\$95.00**

**NV-H80.** Soft carrying case, vinyl, with adjustable shoulder strap. 5.5 lbs. **\$85.00**

**PC-810.** Hard-shell carrying case. **\$135.00**

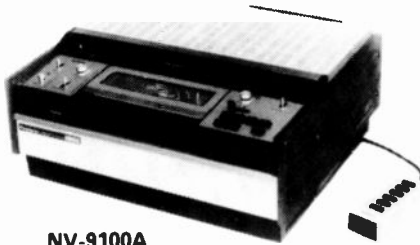

NV-9100A

**NV-9100A 3/4" Videocassette Player.**

Color and Black and White Cassette S/N 47 dB Player. High resolution 330 lines mono, 240 lines color. Two audio channels. Elevator tape loading system. Auto rewind at end of tape Auto repeat playback mode. Auto search mode stops, fast forward or rewind when tape counter reads zero. Non-locking pushbutton controls. Still framing with still frame adjustment. Remote control operation with optional NV-A152. Viewing on conventional TV with optional RF modulator, NV-U134, Ch. 3 or 4 switchable. Dropout/noise compensator. Weight: 76.0 lbs. Dimensions: 21-1/4" x 18-5/8" x 9-3/8" (WHD).

**\$1475.00**



NV-9300A

**NV-9300A 3/4" Videocassette Recorder/Player.**

Recorder/Player equipped with all the features of NV-9100 plus: VHF/UHF Tuners for recording TV broadcasts. Color and Black and White. S/N 47 dB. Resolution 330 lines mono, 240 lines color. Two audio channels. Elevator tape loading system. Auto rewind at end of tape. Auto repeat playback mode. Auto search mode stops fast forward or rewind when tape counter reads zero. Non-locking pushbutton controls. Timer record/play. Still framing with still frame adjustment. Remote control operation with optional NV-A152. Viewing on conventional TV with optional RF modulator, NV-U134, Ch. 3 or 4 switchable. Dropout/noise compensator. Front panel microphone input jacks. Weight: 86.0 lbs. Dimensions: 26-3/16" x 18-15/16" x 4-5/16" (WHD).

**\$2150.00**

**NV-9200A High Performance 3/4" Videocassette Recorder/Player.**

Color and Black and White, two audio level meters, one for each channel; elevator tape loading system. Video level and tracking meters. Direct drive video head cylinder motor, capstan servo system, still frame playback; can be used as source player in videocassette editing system with NV-A950/NV-A960 editing controller; Ext. sync RF carrier output for drop out compensator (DOC) of time base corrector (TBC) and subcarrier input for use with TBC. Auto rewind at end of tape; auto search mode. Remote control operation with optional NV-A152. Weight: 88.0 lbs. Dimensions: 26-3/16" x 18-15/16" x 4-5/16" (WHD).

**\$2500.00**

**NV-9200E High Performance 3/4" U-Format VCR.**

**INTERNATIONAL MODEL**

Record and playback with PAL/SECAM signals; playback only with modified NTSC (4.43 MHz subcarrier). Operates at 100V, 120V, 220V, 240V AC, 60 or 50 Hz. Weight: 88.0 lbs. Dimensions: 26-3/16" x 18-15/16" x 4-5/16" (WHD).

**\$3000.00**

**ACCESSORIES — 3/4" VIDEOCASSETTE SYSTEMS**

**NV-A152.** Remote control unit for basic operation with any Panasonic 3/4" player or recorder/player. Unit has RECORD, PLAY, FAST FORWARD, REWIND, STOP, and PAUSE modes. (with 15 ft. cable). Use with NV-9100A, NV-9200/9200A, NV-9300A, NV-9500/9500A, NV-9240, NV-9600. 2.4 lbs.

**\$100.00**

**NV-U134.** RF Modulator Channel 3 or 4 switchable. Use with NV-8150/NV-8160, NV-8300/NV-8310, NV-9100A, NV-9300A. Weight: 0.6 lbs.

**\$80.00**

**NV-P20.** 3/4" Video Cassette head cleaner tape (approx. 13 ft., 40 sec.), (use when playback picture becomes snowy or indistinct, use no more than 15 seconds for each cleaning). 2.0 lbs.

**\$19.50**

**NV-P23.** 3/4" Video Cassette tape, 611 ft., 30 min. 2.3 lbs.

**\$30.00**

**NV-P26.** 3/4" Video Cassette tape, 1,175 ft., 60 min. 2.6 lbs.

**\$40.00**

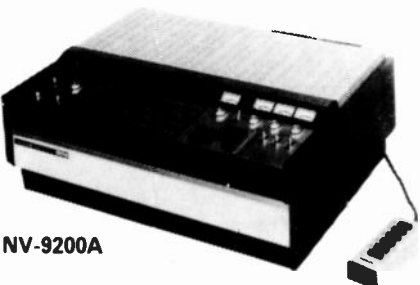

NV-9200A

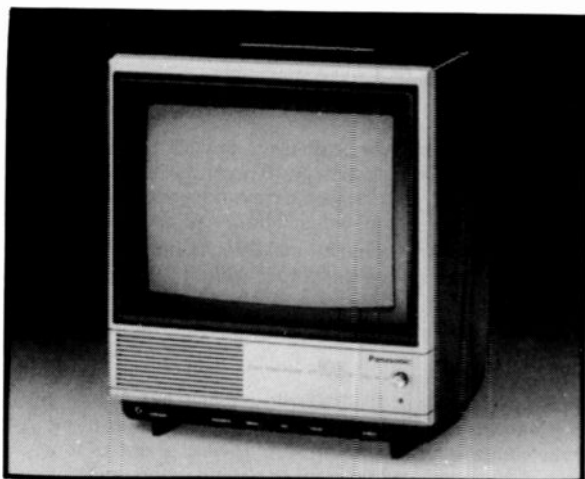

**CT-110M**

**\$485.00**

10" Diagonal Color Video Monitor Quinrix II in-line picture tube optimizes picture quality. ColorPilot electronic color control system. It incorporates 100% solid-state IC chassis for high performance and reliability. The light weight and new sleek design allow the CT-110M to be handled with professional ease, and make the unit ideal for versatile table-top operation. BNC Video, RCA audio connectors grip. Commercial UL listing.



**CT-1320M**

**\$495.00**

The Panasonic CT-1320M is a 13" (measured diagonally) color video monitor incorporating the most recent advancements in TV technology. This video monitor uses the Quinrix II in-line picture tube for a clear, sharp picture with a jet black background for excellent contrast. This video monitor features; 100% solid-state IC chassis; ColorPilot that receives the incoming color and tint signals and adjusts the color quality to pre-selected levels; Quick-on picture tube; Panabrite for color, contrast and brightness; Sharpness control. CT-1320M has BNC connectors for video input and output, RCA-type audio connectors and 8-pin connector for use with VTR, video cartridge and cassette recorders and 4" round speaker.



**CT-1320V**

**\$595.00**

The Panasonic CT-1320V is a 13" (measured diagonally) color video receiver/monitor incorporating the most recent advancement in TV technology. This video receiver/monitor features ColorPilot to receive the incoming color and tint signals and automatically adjust the color quality to your pre-selected levels; Quick-on picture tube; Panalock Automatic Fine Tuning; Panabrite for automatic color, contrast and brightness control; Connectors for input and output; Video BNC, RCA-type audio connectors and an 8-pin connector for VTR. It also features single-axis electronic tuning, impedance on/off switch, whiteness enhancer, monitor out and of course, our famous Quinrix II in-line picture tube for the best in video entertainment.

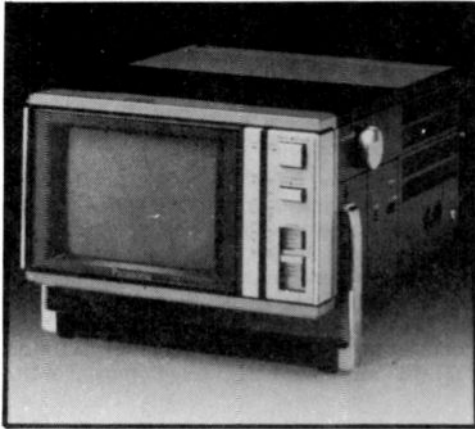

**CT-500V**

**\$475.00**

5" (Measured diagonally) AC/DC color video receiver/monitor. This compact, lightweight color monitor is ideal for ENG (Electronic News Gathering) monitoring on the spot. 3-way operation (AC/car battery/rechargeable battery or dry batteries) permits use almost anywhere. Panabrite control system performs simultaneous adjustment of proper brightness, contrast and color saturation. Built-in VHF/UHF tuner permits standard broadcast reception. TV/Line select switch. TV video/audio out. (Optional accessories: TY-A26 battery case; TY-3611R Panaloid rechargeable battery).

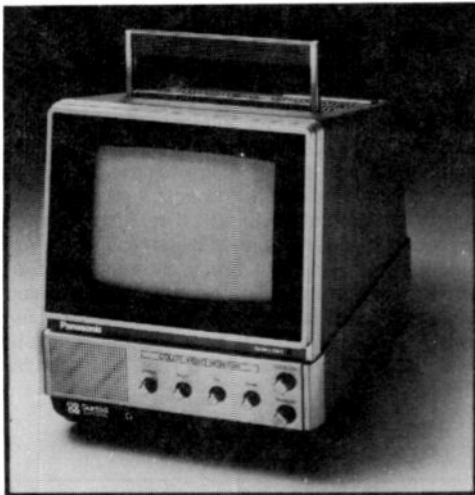

**CT-700M**

**\$495.00**

The Panasonic CT-700M is an AC or DC-operated 7" (measured diagonally) color video monitor. This video monitor uses the Quintrix II in-line picture tube for a clear, sharp picture with a jet-black background for excellent contrast. It also features: 100 percent solid-state IC chassis; Quick-on picture tube; Panabrite dial for manual adjustment of color, contrast and brightness; BNC video connectors; RCA audio connectors; earphone jack; and a built-in 2-1/2" round speaker. The CT-700M may be used indoors, in an office or studio application powered from an AC outlet or outdoors, in ENG field operation to check camera color quality, or anywhere a 12 or 24 volt DC power source is available. In DC operation the monitor automatically adjusts to the 12 or 24 volt DC input. A car adaptor is furnished as standard and the monitor has a front-mounted LED to warn of inadequate voltage input.

A convenient fold-down handle is provided for easy carrying of the CT-700M.

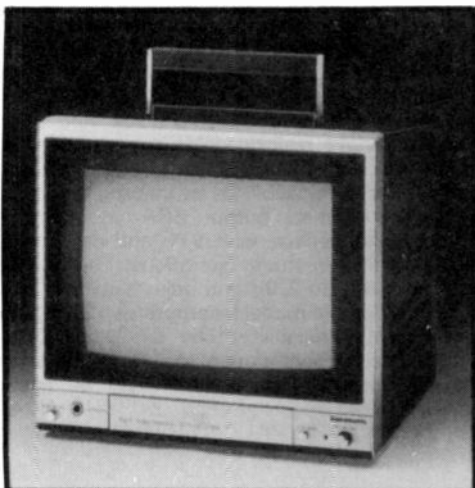

**CT-110MA**

**\$475.00**

10" (Measured diagonally) Color Video Monitor. It features Quintrix II in-line picture tube, 100% solid-state IC chassis, ColorPilot electronic color control system, quick-on, metal cabinet and Panabrite control for simultaneous adjustment of color, contrast and brightness. A carrying handle makes it easy to transport from place to place. The rear panel outputs including BNC video, RCA audio and 8-pin connector for VTR/VCR connection. Horizontal AFC select VTR or normal. Commercial UL listing.

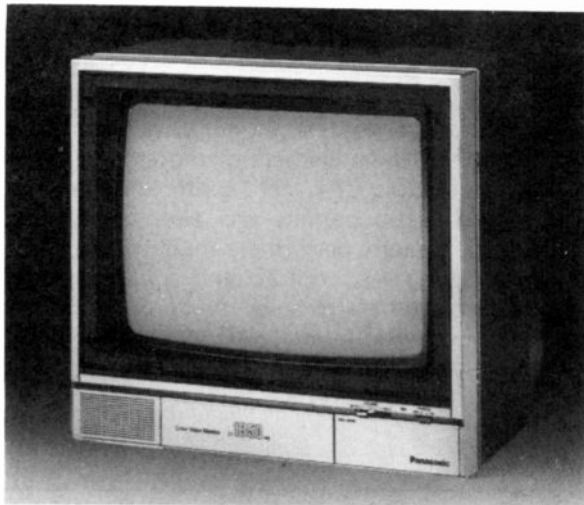

**CT-1350MG**

**\$585.00**

13" (measured diagonally) NTSC/RGB Rackmountable Color Video Monitor. This color monitor is specifically engineered to satisfy the industrial, professional, educational demands with computer and VTR/VCR applications. NTSC composite and RGB inputs are provided for professional studio or RGB computer applications. Video input: 1.0 Vp-p 75 ohms unbalanced, loop through, BNC connector. RGB Output: TTL level 4.0 Vp-p, 8-pin connector. Selection between the two modes is performed with a simple pushbutton. (Optional accessory: CT-T30 rackmount adaptor). Commercial UL listing.

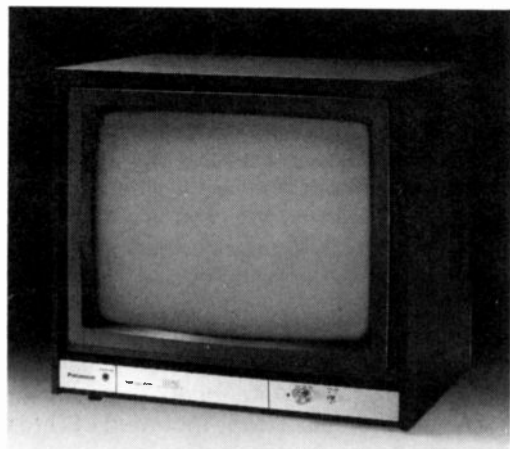

**CT-1920M**

**\$645.00**

19" (measured diagonally) Color Video Monitor. High performance NTSC color monitor with ColorPilot system that receives the incoming color and tint signals and adjusts color quality to pre-selected levels. The Panabrite control system performs simultaneous adjustment of brightness, contrast and color. Quinatrix II in-line picture tube delivers a clear, sharp picture at all times with 320 line resolution for finer picture detail. Comb filter improves resolution and color definition by reducing color noise. Quick-on feature eliminates warm-up time. Inside, the 100% solid-state IC chassis is used to guarantee excellent reliability. Equipped with BNC connectors for video input and output, 8-pin VTR connector and RCA-type audio connectors. Commercial UL listing.

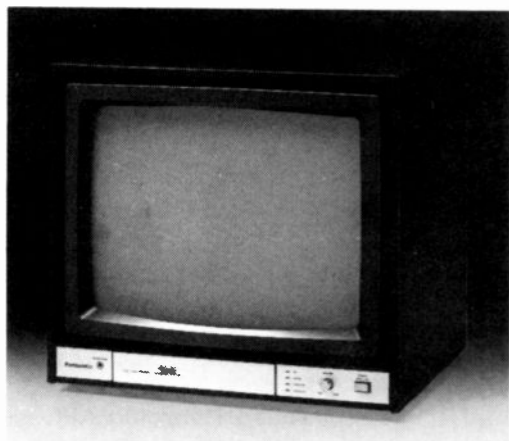

**CT-2000M**

**\$995.00**

Panasonic introduces a 19" (measured diagonally) 4 system color video monitor incorporating many of the most up-to-date innovations in TV technology for high quality viewing in educational and industrial applications. The CT-2000M Color Monitor offers 4 System capability, enabling the monitor to receive PAL/SECAM/3.58NTSC/4.43NTSC signals — significantly simplifying international use of the different standards of video cassette recorders. The CT-2000M also features of the Quinatrix II In-Line picture tube with a Black Matrix configuration and ColorPilot for bright realistic color reproduction, outstanding contrast and linearity — all adding up to exceptional picture quality. A varied array of connection possibilities are incorporated including BNC connectors for video input and output, RCA-type audio connectors, and an 8-pin connector for use with VTR and cassette recorder — affording high versatility in studio operations. The unit accepts line voltage inputs from 80V to 290V and adjusts to that power source automatically. This durable model incorporates 100% Solid State IC chassis to help assure reliability. The CT-2000M Color Monitor exemplifies the Panasonic commitment to state-of-the-art engineering and superb performance. This monitor may be used with the NV-9200E PAL/SECAM recorder, and ½" VHS NV-8200E PAL recorder/player or NV-8170E PAL/NTSC (4.43 MHz) player.



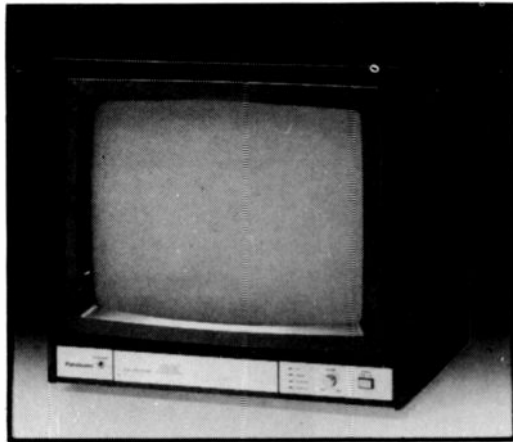

**CT-2000M**

**\$995.00**

19" Diagonal 4-System Color Video Monitor. The CT-2000M is a four-system color monitor for PAL, SECAM, 3.58NTSC, and 4.43NTSC for an unprecedented degree of versatility. It is capable of receiving all the world's major broadcasts with optional tuners, PAL/SECAM/NTSC and playing back PAL/SECAM/NTSC and playing back PAL/SECAM/NTSC recorded video tapes. The switchover is automatic and manual. "AC Auto" system adjusts the monitor to power sources from 80V to 290V automatically. Quinatrix II in-lines picture tube provides clear, sharp picture with an extra pefocus lens. For excellent reliability and ease of maintenance, the chassis is 100% IC solid-state. A full array of inputs and outputs with a loop-through capability permits use in almost any types of application.

**PROJECTION TV**

**General Features**

- Available in floor, ceiling mounted, and rear projection types, the CT-17000 series is ideal for any location
- Image size is completely adjustable: 50" x 100" (Diagonal) with the CT-10000M; 120" x 170" (Diagonal) with the CT-17000M series
- Strikingly sharp and bright picture quality thanks to 3-tube system employing 13" (17000M series) and 7" (10000M) CRTs and precision wide projection lenses
- Handles every type of video input, from color cameras and VTRs to computer graphics
- Simple operation—as easy to use as color monitors
- Needs no special screen. Any high quality screen will provide satisfactory results. (Silver screen recommended)
- Equipped with built-in high voltage protection circuitry

**CT-10000M**

**\$7000.00**

For high image quality on a screen size between 50" and 100" (diagonal) (adjustable but preset at the factory for 50" 72" or 100" on request), this ceiling mounted 3-tube video projector is ideal. Any screen on the market can be used. Saves floor space and has dual input signal mode functions for easy interfacing with any RGB/composite signal source.

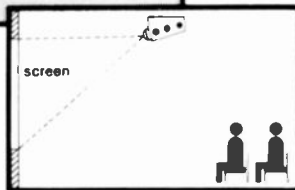
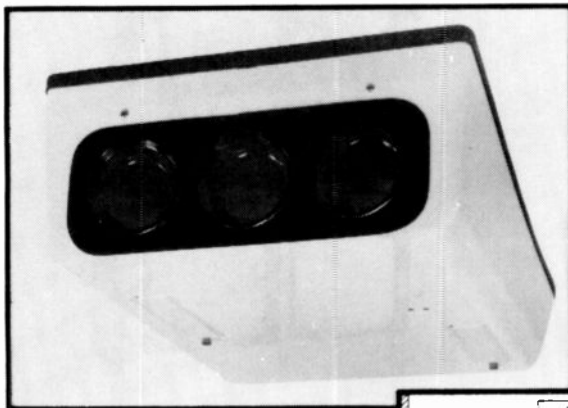

**CT-17000M**

**\$35,000.00**

A floor-use model mounted on casters to provide an image from 120" to 170" (diagonal) (preset for 120" or 170" use) with a short throw distance (161/3 feet) to allow a large audience to sit behind the projector.

Three 13" CRTs and direct through-the-lens projection assure very high resolution, a bright image and comfortably viewable picture over a very wide angle.

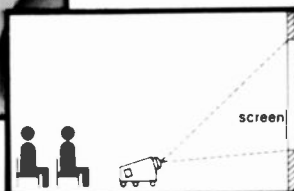



TR-930



WV-5200B



WV-5203B



WV-5400B

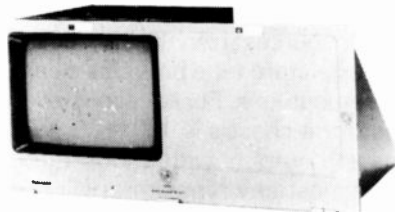

TR-931

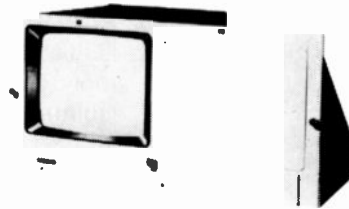

WV-5351



WV-5360

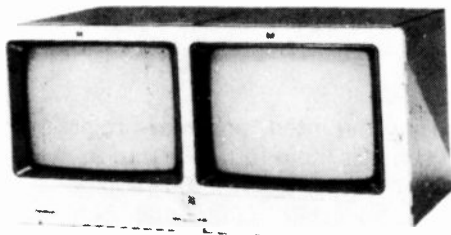

TR-932

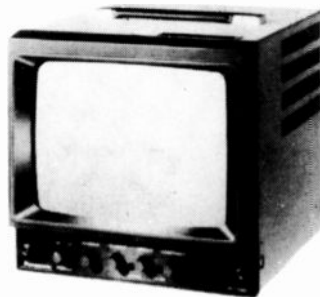

WV-5350

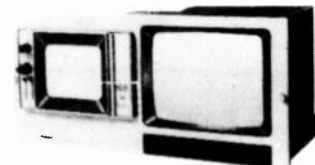

WV-5361  
TEK 528 WFM (not included)

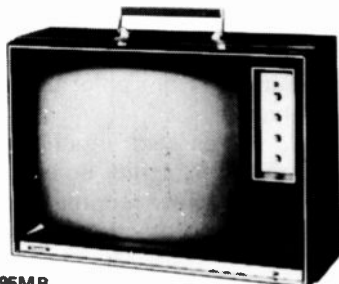

TR-195MB

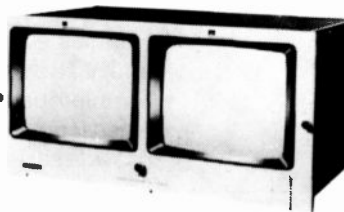

WV-5352



WV-5362

## BLACK AND WHITE CCTV MONITORS

**TR-930.** 9" (measured diagonally) desktop monitor front panel operating controls more than 700 lines at center; all solid state\*. 11.2 lbs. **\$185.00**

**TR-931.** 9" (measured diagonally) CCTV monitor in rack mount chassis with blank panel for additional equipment front panel operating controls more than 700 lines at center; all solid state. 17.2 lbs. **\$220.00**

**TR-932.** Dual 9" (measured diagonally) CCTV monitor in rack mount chassis; front panel operating controls more than 700 lines at center; all solid state\*. 27.8 lbs. **\$400.00**

**TR-195MB.** 184 sq. in. (19" diagonal), all solid state\*, UHF, RCA and 8-pin connectors for VTR playback function. 49.5 lbs. **\$330.00**

**WV-5200B** 16 sq. in. (5" diagonal), all solid state\*; more than 600 lines at center; Int or Ext sync. Short H. AFC. 15.0 lbs. **\$275.00**

**WV-5203B** Triple 16 sq. in. (5" diagonal), CCTV monitors for 19" rack, all solid state\*. 42.0 lbs. **\$825.00**

**WV-5351.** 9" (measured diagonally) CCTV Monitor in a rack mount chassis with blank panel for additional equipment; more than 700 lines at center; DC restoration; all solid state\*. 28.1 lbs. **\$320.00**

**WV-5350.** 9" (measured diagonally) desktop CCTV Monitor, more than 700 lines at center, DC restoration; all solid state\*; Int Ext sync. 17.5 lbs. **\$275.00**

**WV-5352.** Dual 9" (measured diagonally) CCTV Monitors in rack mount chassis, more than 700 lines at center; DC restoration; all solid state\*. 37.4 lbs. **\$570.00**

**WV-Q20.** WV-5400 Rack mount angle bracket for standard 19" EIA rack. 3.2 lbs. **\$25.00**

**WV-5400B** 14" diagonal desktop Monitor; 700 lines resolution at center; internal/external sync, DC restoration and short H. AFC time constant. Optional brackets WV-Q20 available for rack mounting. 28.6 lbs. **\$350.00**

**WV-5360.** Deluxe 9" (measured diagonally) desktop Video monitor, more than 700 lines at center. Underscan and DC restoration; Audio monitor/speaker; 8-pin connector, cross-pulse, all solid state\*. 18.8 lbs. **\$395.00**

**WV-5361.** Deluxe 9" (measured diagonally) rack mounted Video Monitor. Includes blank panel for a Tektronix 528 waveform monitor (not supplied) 700 lines at center; DC restoration; 8-pin connector; cross-pulse; all solid state\*. 28.8 lbs. **\$445.00**

**WV-5362.** Dual deluxe 9" (measured diagonally) Video monitor in a rack mount chassis. More than 700 lines resolution at center; underscan and DC restoration; 8-pin connector, cross-pulse; all solid state\*. 41.1 lbs. **\$795.00**

\*Except for picture tube.

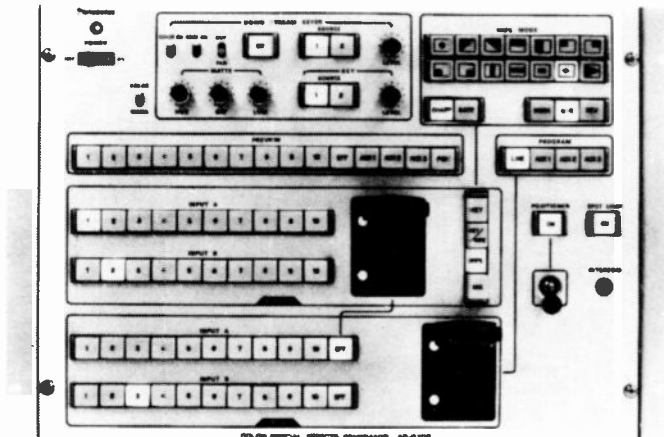

AS-6100

**Special Effects Generator**

**AS-6100** For a self-contained broadcast quality special effects generator, Panasonic introduces model AS-6100, the latest generation of advanced color video signal equipment. AS-6100 features ten video inputs, 4 input buses, two sets of fade/wipe levers, fourteen wipe patterns, positioner, spotlight, colorizer, two downstream key inputs, two external inputs plus auxiliary inputs. All this provides a wide variety of special effects for creative television programming.

This special effects generator is ideal for use with the Panasonic AK-920 and AK-750 broadcast quality cameras, and can be used with any NTSC color television production system. And because it is a self-contained special effects generator, it is also ideal for a mobile production unit. **\$7500.00**

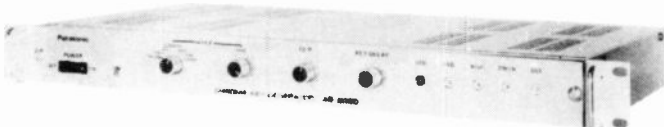

AS-2000

**Chroma Key Generator**

**AS-2000** The AS-2000 chroma key generator adds an extra dimension of special effects to the AS-6100 SEG. It can also be used with other special effects generators that accept external key signals. Coarse and fine hue adjustments are provided by a rotary switch and variable resistor; the key signal delay is adjusted by a second variable resistor. Non-composite RGB inputs are required. **\$1200.00**



AS-1000

**Color Sync Generator**

**AS-1000** The AS-1000 color sync generator produces broadcast-stable EIA RS-170 sync using a crystal oscillator. It also genlocks to incoming, non-synchronous composite video signals or composite sync. For studio adjustments it generates encoded EIA RS-189 and full field color bars with adjustable phase. AS-1000 also has a built-in subcarrier distribution amplifier to provide four subcarrier outputs: one with fixed phase and three with independently adjustable phase. **\$2000.00**

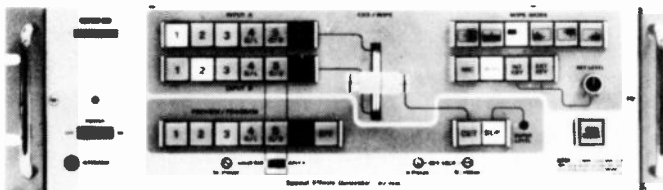

WJ-4600A

**Economical Color Special Effects Generator**

**WJ-4600A** • Inputs: 6 program inputs, 1 super (internal key) input, 1 external key (monochrome) input. • Functions: Vertical interval switching, Fades and dissolves, Six wipe patterns, Super (internal key), External key. • Non-locking pushbuttons light up when pressed to show inputs and function selected. • "CUT" pushbutton transfer program and preview buses. • Built-in sync and color bar generator. • Accepts composite or non-composite inputs (all must be same type). • BNC connectors. • Effect, preview, and two program outputs. • Supplies intercom power to six cameras. • Supplies tally light on/off switching to all eight inputs. • Requires just 5 1/4" of standard EIA rack space. • RS170A Sync • Blackburst Output. **\$2095.00**

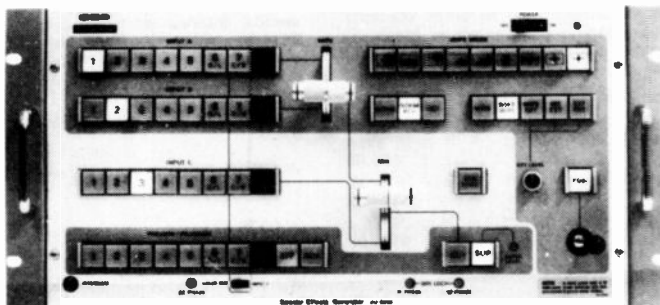

WJ-5500A

**Deluxe Color Special Effects Generator**

**WJ-5500A** • Inputs: 7 program inputs, 1 aux input for VTR, 1 key input, 1 for internally-generated color bars or black burst. • Functions: SWITCH/MIX — Vertical interval switching; WIPE — Nine wipe patterns; KEY. • Non-locking pushbuttons light up when pressed to show inputs and function selected. • "CUT" pushbutton transfers program and preview buses. • Built-in sync, color bar, and black burst generator. • Can mix composite and non-composite inputs. • BNC connectors. • Effect, preview, and two program outputs. • Supplies intercom power to seven cameras. • Supplies tally light on/off switching to eight cameras. • Requires 8 3/4" of standard EIA rack space. • RS170A Sync • Blackburst Output. **\$3950.00**

# Panasonic

VIDEO SYSTEMS DIVISION



WV-1650

WV-1600

WV-1790



WV-1780



MN-518



MN-815



KF-85A



KF-16A

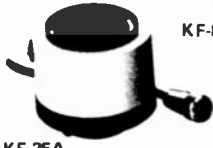

KF-25A

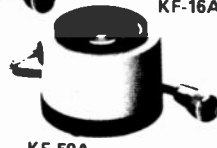

KF-50A

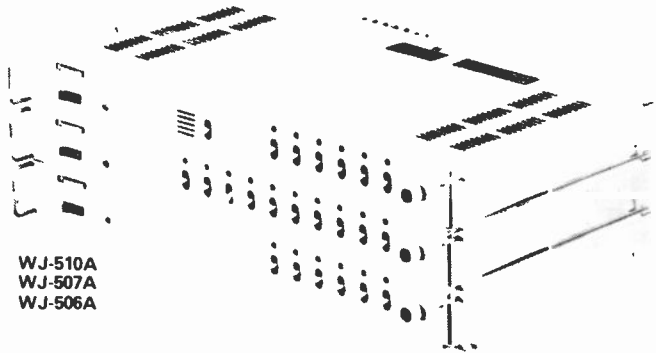

WJ-510A  
WJ-507A  
WJ-506A

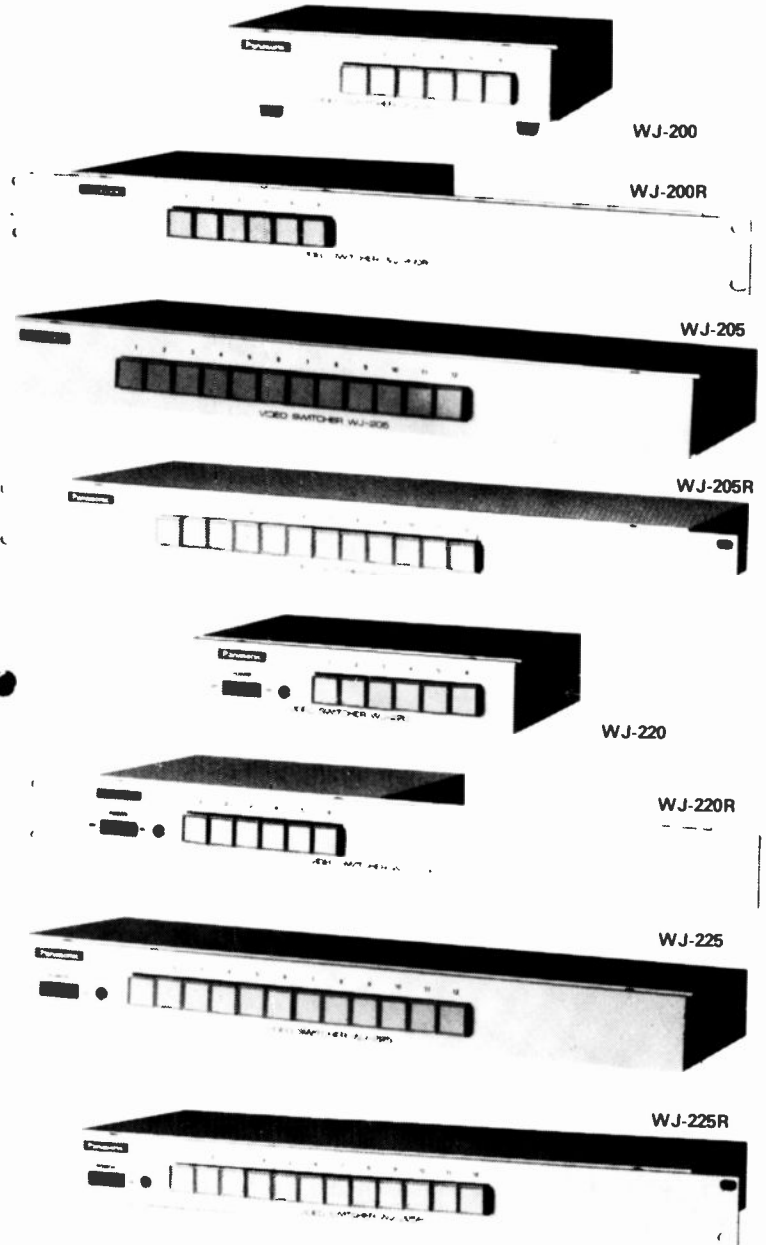

WJ-200

WJ-200R

WJ-205

WJ-205R

WJ-220

WJ-220R

WJ-225

WJ-225R

## SINGLE CABLE COMPACT CCTV CAMERA SYSTEMS

**WV-1600/KT1.** Single-cable Vidicon Camera with 16mm. F/1.6 C-mount lens, internal line lock random interlace. Comes with AC power Camera Control box, AC 120V, 60Hz. 1.3 lbs. **\$350.00**

**WV-1600/KT2.** Single-cable Vidicon Camera with 16mm. F/1.6 C-mount lens, internal random interlace. Comes with DC power Camera Control box, DC 12V, 1.3 lbs. **\$350.00**

**WV-1650/KT1.** Single-cable Newvicon Camera (body only; without lens). C-mount (optional Auto Iris lens required), internal line lock random interlace. Comes with AC power Camera Control box, AC 120V, 60Hz. 1.2 lbs. **\$800.00**

**WV-1650/KT2.** Single-cable Newvicon Camera (body only; without lens). C-mount (optional Auto Iris lens required), internal random interlace. Comes with DC power Camera Control box, DC 12V. 1.2 lbs. **\$800.00**

### Passive Switchers

- Designed for reliability; premium quality switch utilized to provide positive, trouble-free switching.
- Compact and economical. • Mechanical switching.
- All inputs are terminated with 75 ohms (excepts one whose corresponding pushbutton is pressed).
- Lock/release-type switch. • Card holder permits each input to be labeled.

**WJ-200** 6 input—desk mount 1 1/4" H x 8 1/4" W x 5 1/4" D **\$95.00**

**WJ-200R** 6 input — rack mount 1 1/4" H x 19" W x 5 1/4" D **\$95.00**

**WJ-205** 12 input — desk mount 1 1/4" H x 16 1/2" W x 5 1/4" D **\$175.00**

**JW-205R** 12 input — rack mount 1 1/4" H x 19" W x 5 1/4" D **\$175.00**

### Sequential Switchers

**WJ-506A** (six inputs), **WJ-507A** (ten inputs), and **WJ-510A** (six inputs plus alarm) are full automatic sequential switchers for multi-camera CCTV systems. Features spot monitor/auto/bypass switch, and adjustable time display (1 to 30 seconds). Switching can also be controlled by the time lapse VTR, NV-8030, or by another switcher. **WJ-510A** is an auto alarm switcher ideally mated for NV-8030 time lapse VTR; includes inputs for six cameras and six alarm sensors.

**WJ-510A** \$525.00  
**WJ-507A** \$475.00  
**WJ-506A** \$375.00

### Active Switchers

- Designed for reliability, with solid state circuitry.
- Excellent picture reproduction, with minimum crosstalk and low frequency transients. • Electronic, vertical interval switching. • Unterminated loop-through video inputs. • Illuminated, non-locking pushbuttons. • Card holder permits each input to be labeled.

**WJ-220** 6 input — desk mount 1 1/4" H x 8 1/4" W x 5 1/4" D **\$225.00**

**WJ-220R** 6 input — rack mount 1 1/4" H x 19" W x 5 1/4" D **\$225.00**

**WJ-225** 12 input — desk mount 1 1/4" H x 16 1/2" W x 5 1/4" D **\$350.00**

**WJ-225R** 12 input — rack mount 1 1/4" H x 19" W x 5 1/4" D **\$350.00**

### C-Mount Lenses

**MN-815** 8.5mm f1.5, wide angle **\$95.00**  
**MN-518** 50mm f1.8 telephoto lens **\$80.00**

### Automatic Iris Control Lenses

**KF-85A** F:1.5 Wide angle lens f:8.5mm **\$350.00**  
**KF-16A** Normal lens F:1.6 f:16mm **\$320.00**  
**KF-25A** Telephoto lenses F:1.4 f:25mm **\$340.00**  
**KF-50A** F:1.8 f:50mm **\$340.00**

Prices and Specifications Subject to Change Without Notice.

# Panasonic

VIDEO SYSTEMS DIVISION



## CAMERA MOUNTING BRACKETS AND HOUSINGS

**WV-7010.** Ceiling bracket, lightweight duty, indoor, universal head. Use with WV-1000/1000A series w/fixed focal lens. WV-7120 Housing. 0.8 lbs. \$17.50

**WV-7015.** Wall bracket, lightweight duty, indoor, universal head. Use with WV-1000/1000A series w/fixed focal lens. WV-7120 Housing. 1.8 lbs. \$25.00

**WV-831.** Wall bracket, medium weight, indoor, universal head. Use with WV-1000/1000A series w/zoom lens. WV-7130 Housing. 3.5 lbs. \$40.00

**WV-7030.** Wall mount, heavy duty indoor. Use with WV-7220 Pan mechanism, WV-7230 Pan/tilt mechanism, WV-7130 Housing. 6.2 lbs. \$55.00

**WV-7060.** Outdoor mount, heavy duty. Mounts on flat surface. Has pan and tilt adjustments. Use with WV-7150 Housing or WV-7160 Housing. 9.4 lbs. \$37.50

**WV-7120.** Dustproof indoor housing, mounts from top. Use with WV-1000/1000A series w/fixed focal lens. 3.5 lbs. \$60.00

**WV-7130.** Dustproof indoor housing, mounts from top. Use with WV-1000/1000A series w/zoom lens. 8.7 lbs. \$100.00

**WV-7150.** Outdoor camera housing. Contains thermostatically controlled heater and fan. Use with WV-1000/1000A series w/fixed focal lens. WV-7060 Mount. 28.6 lbs. \$350.00

**WV-7160.** Outdoor camera housing. Contains thermostatically controlled heater and fan. Built-in defroster. Use with WV-1000/1000A series TV camera w/zoom lens. WV-7060 Mount. WV-7260 Pan/tilt mechanism. 34.2 lbs. \$450.00

**WV-250.** Wiper assembly. Use with WV-7160 Camera housing. 7.3 lbs. \$150.00

**WV-1710** (not shown). Outdoor, drip-free housing for single cable cameras. Use with WV-1600 or WV-1650. 6.5 lbs. \$85.00

## CAMERA CABLES

**10G-25.** 10-Pin multiconnector cable w/male connectors (25 ft.). 2.5 lbs. \$70.00

**10G-50.** 10-Pin multiconnector cable w/male connectors (50 ft.). 5.5 lbs. \$110.00

**10H-25.** 10-Pin multiconnector extension cable w/male and female connectors (25 ft.). 2.5 lbs. \$70.00

**10H-50.** 10-Pin multiconnector extension cable w/male and female connectors (50 ft.). 5.5 lbs. \$110.00

**VEC-25.** Camera extension coaxial cable (25 ft.) w/UHF connectors. 1.4 lbs. \$20.00

**VEC-50.** Camera extension coaxial cable (50 ft.) w/UHF connectors. 2.3 lbs. \$35.00

**VEC-100.** Camera extension coaxial cable (100 ft.) w/UHF connectors. 3.8 lbs. \$60.00

**VP-4.** Standard Tripod. 5.0 lbs. \$70.00

## ACCESSORY CABLES

**WV-360.** Video adaptor cable (UHF 8-pin connector) for VTR and monitor. 0.4 lbs. \$20.00

**NV-C15.** TV Control Cable (5 feet), 8-pin to 8-pin male connectors. 0.8 lbs. \$18.50

**NV-C21.** VTR/TV Extension Cable (10 feet), male and female connectors, 8-pin to 8-pin. 1.6 lbs. \$24.50

# Panasonic

VIDEO SYSTEMS DIVISION

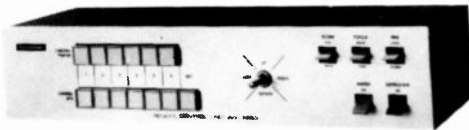

WV-7490

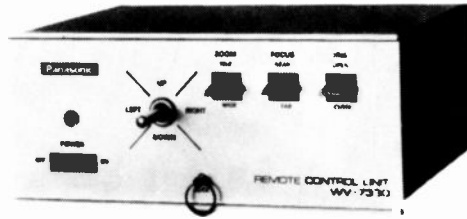

WV-7330

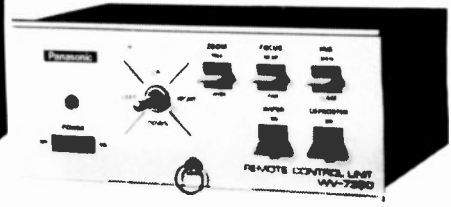

WV-7360

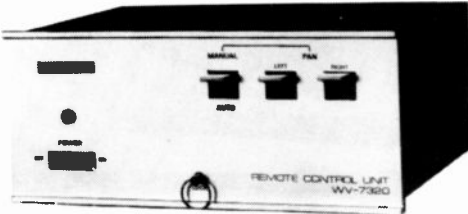

WV-7320



WV-7430

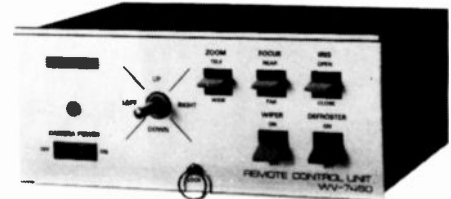

WV-7460

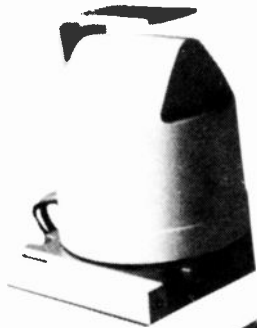

WV-7260



WV-7220

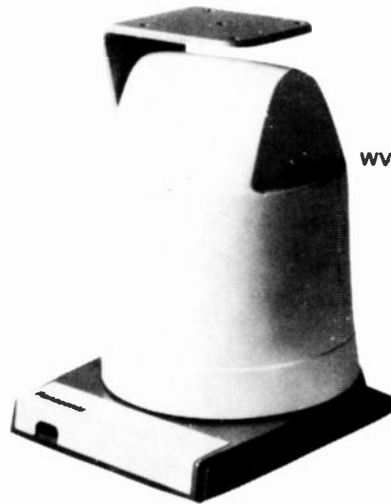

WV-7230

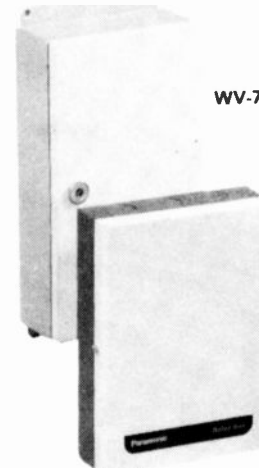

WV-7465

WV-7435

## PANNING UNITS

## REMOTE CONTROL UNITS AND RELAY BOXES

**WV-7220.** Standard Indoor Panning Head; mountable on ceiling or bracket-mount on flat surface; adjustable panning angle 20° - 320°. Requires optional remote control unit, WV-7320. 6.3 lbs. **\$185.00**

**WV-7230.** Deluxe indoor remote controlled Pan/Tilt mechanism head, ceiling or bracket mount on flat surface; adjustable panning angle: tilting angle up 45° down 45°; pan speed 6.0°/sec; tilt speed 3.0°/sec; supplies 24V AC power to low voltage camera. Requires remote control unit (WV-7330, WV-7430 or WV-7490 with relay box WV-7435). 17.6 lbs. **\$495.00**

**WV-7260.** Heavy duty outdoor, remote controlled pan/tilt mechanism head; requires bracket mount on flat surface; adjustable panning angle 10° - 340°; tilting angle; up 15°, down 60°; pan speed 7.0°/sec. Supplies 24V AC power to low voltage camera and housing. Requires remote control unit (WV-7360, WV-7460 or WV-7490 with relay box WV-7465). 51.0 lbs. **\$850.00**

**WV-7320.** Remote Control unit for operating optional WV-7220 panning head. Controls on/off (24V AC) power for TV camera and panning mechanism, rack mountable with optional rack mount frame. 6.6 lbs. **\$135.00**

**WV-7330.** Remote Control unit for WV-7230 pan/tilt mechanism. Controls on/off (24V AC) power for TV camera, zoom, focusing and iris for zoom lens and pan/tilt mechanism. Rack mountable with optional rack mount frame. Joystick control for pan and tilt. 7.7 lbs. **\$285.00**

**WV-7430.** Remote Control unit for WV-7230. Controls on/off (24V AC) power for TV camera, focusing, iris for zoom and pan/tilt mechanism. Rack mountable with optional rack mount frames. Joystick, control for panning and tilting. Requires relay box WV-7435. 5.5 lbs. **\$125.00**

**WV-7360.** Remote Control unit for WV-7260 controls on/off (24V AC) power for TV camera, zooming, focusing, iris for zoom lens, pan/tilt mechanism, defroster and wiper for outdoor housing. Rack mountable with optional rack mount frame. Joystick controls for panning and tilting. 8.8 lbs. **\$340.00**

**WV-7460.** Remote Control unit for WV-7260. Controls on/off (24V AC) power for TV camera, zooming, focusing, iris for zoom lens, pan/tilt mechanism, defroster and wiper for outdoor housing. Rack mountable with optional rack mount frame. Joystick controls for pan and tilt. Requires relay box WV-7465. 5.5 lbs. **\$185.00**

**WV-7490.** Remote Control unit for WV-7260 and WV-7230. Controls on/off (24V AC) power for TV camera, zooming, focusing, iris for zoom, pan/tilt mechanism, defroster and wiper for outdoor housing; controls 6 sets of pan/tilt mechanism, zoom lenses and housings. Rack mountable with optional rack mount frame. Joystick controls for pan and tilt; requires relay box WV-7435 (indoor) or WV-7465 (outdoor). 8.8 lbs. **\$395.00**

**WV-7435.** Relay Box, indoor, with 24V, AC power Built-in for TV camera and pan/tilt mechanism. For use with WV-7230 pan/tilt mechanism; WV-7430 remote control; or WV-7490 remote control. 11.0 lbs. **\$285.00**

**WV-7465.** Relay Box, outdoor. Extends control between pan/tilt mechanism and remote control unit. For use with WV-7260 pan/tilt mechanism; WV-7460 remote control; WV-7490 remote control. 16.8 lbs. **\$350.00**



Typical Student Configuration consisting of Student Computer, Student Address Unit and optional video cassette player, printer and monitor.

**INTERACTIVE VIDEO TRAINING SYSTEM**

The system is particularly suited to corporate and industrial training programs, and is outstanding in flexibility and simplicity of operation. The system combines advanced computer and video technologies to provide a unique efficient, self-paced learning technique designed for educational and institutional applications also.

The Interactive Video Training System personalizes video training. It allows for constant testing and evaluation of a student's results, and offers built-in review capabilities. The course and pace of the training tape is determined by each student's capability and comprehension, as the system tests him while the tape proceeds. The student's answers to particular questions posed during the tape directs the computer to proceed to the next segment, back up to review remedial information or skip to a more advanced section of the tape.

This flexible system allows for comprehension test questions to be posed at any point on the tape. Based on the student's responses, the micro-processor computer system can access up to 199 specific segments on a video tape. The system is easy to use, as the student only works with a monitor and hand-held remote control unit. By utilizing a Panasonic industrial VHS Machine, up to two hours of program material can be used.

The Interactive Video System is also easy for the trainer to use. A trainer with no knowledge of computers or computer language can learn to format the video tape in a matter of hours. Existing linear instruction tapes can be turned into basic interactive training tapes without the need for complicated video edits, because the digital computer information is logged onto one of the tape's audio channels. The new Panasonic system can produce simple tapes or sophisticated programs through its "branching" properties. This branching capability allows the varying quality of a student's answer to trigger switches to segments of the training tape at corresponding skill levels. This capability generates widely diverse tracks of learning to help assure inclusive understanding of the training material.

The Interactive Video Training System consists of a student system with an Interactive Computer, a Student address Unit and a printer. The Master Tape Programming System has a printer, Master Tape Programmer and a Text Writer. All of these work in conjunction with any Panasonic VHS 2-channel full logic solenoid video recorder or player and any Panasonic video monitor/receiver or standard TV. The microprocessor-controlled Interactive Computer is compact and sits under a Panasonic VHS NV-8170 or NV-8200 player or recorder. The Student Address unit is an easy-to-use 18 button key pad that plugs into the computer and is the only control the student needs. The system's Master Tape Programmer provides step-by-step instructions for programming the master tape, with the instructions displayed on the monitor screen. The Text Writer, similar to a typewriter, generates a single page of 32 characters by 16 lines. The Text Writer enables text to be added after the video editing process is complete, and can reformat or update the tape at any time or revise questions without video editing.

An optional printer is available with the Interactive Video Training System. This printer provides hard copy verification of the student's answers, time taken to answer questions, degree of correctness and score achieved for particular questions. The printer also aids in the preparation of tapes, providing the instructor hard copy verification of all entered data in the master programming sequence.

In addition to standard NV-8170, NV-8200, NV-8500 1/2" VHS tape format machines, Panasonic's Interactive Video Training System is also compatible with NV-9240 and NV-9600 3/4" player/recorder machines, and the broadcast AU-700 series.

Master Programmer .....	\$2300.00 (approx.)
Text Writer .....	750.00 (approx.)
Computer with Addresser .....	900.00 (approx.)
Printer .....	600.00 (approx.)

# Panasonic

VIDEO SYSTEMS DIVISION



1100 Series

## 1100 SERIES VTR RECORDING MICROPHONES

This low-cost microphone series, designed primarily for tape recording use, features five models: WM-1100 for non-musical applications; WM-1150 for voice applications; WM-1151 for clear speech recording; WM-1181 for outdoor speech and interviewing; and the WM-1610 tie-clip model for use in high fidelity sound applications for television or lectures.

**WM-1100.** Omni-directional dynamic microphone. Impedance 400 ohms. Suitable for non-musical VTR recording. 1/4" phone plug and 6.5 ft. cable. Desk stand included. 1.5 lbs. **\$18.95**

**WM-1150.** Uni-directional dynamic microphone with cardioid directional response. Impedance 400 ohms. Suitable for voice VTR recording. ON-OFF talk switch. 1/4" phone plug and 9.8 ft. cable. Stand adaptor included. 1.5 lbs. **\$27.95**

**WM-1151.** Uni-directional dynamic microphone with cardioid directional response. Impedance 400 ohms. Suitable for clear speech VTR recording. ON-OFF talk switch. 1/4" phone plug and 6 1/2 ft. cable. Stand adaptor and desk top stand included. 2.2 lbs. **\$32.95**

**WM-1181.** Uni-directional dynamic microphone with cardioid directional response. Impedance 400 ohms designed for outdoor voice recording. 1/4" phone plug and 16.4 ft. cable. Stand adaptor included. 1.5 lbs. **\$49.95**

**WM-1610.** Omni-directional miniature electret condenser microphone. Impedance 600 ohms. Designed for hand-free operations in television, video recording, lecture and other applications. Tie-clip holder and H-C mercury cell battery and 10 ft. cable supplied. 1.5 lbs. **\$29.95**

## 1300 SERIES GENERAL PURPOSE MICROPHONES

This general purpose 1300 series contains five models: WM-1315 for use in public address systems; WM-1323 for use in meeting rooms or auditoriums; WM-1325 for vocal or percussion pick-up in school music rooms, bars or discos, WM-1326 for music applications, including voice, brass and percussion instruments; and WM-1400 for use in large halls, auditoriums or theaters.

**WM-1315.** Uni-directional dynamic microphone. Impedance 200 ohms, unbalanced. Suitable for clear voice applications in public address. 15 ft. cable with a 1/4" phone plug. A stand adaptor supplied. 1.4 lbs. **\$49.95**



1500 Series



1300 Series

**WM-1323.** Uni-directional dynamic microphone. Impedance 200 ohms or 20k ohms switchable. Unbalanced or balanced type changeable. Designed for very directional and clear crisp voice reproduction. ON-OFF talk switch. 15 ft. cable with a cannon connector and a 1/4" phone plug. A stand adaptor supplied. 1.4 lbs. **\$79.95**

**WM-1325.** Uni-directional dynamic microphone. Impedance 200 ohms. Unbalanced or balanced type changeable. Suitable for vocal or percussion sound pick-up. ON-OFF talk switch. 15 ft. cable with a cannon connector and a 1/4" phone plug, a stand adaptor supplied. 1.6 lbs. **\$84.95**

**WM-1326.** Uni-directional dynamic microphone. Impedance 400 ohms. Unbalanced or balanced type changeable. Outstanding in musical application on stage for vocal with brass and percussion instruments. ON-OFF talk switch. 15 ft. cable with a cannon connector and a 1/4" phone plug, a stand adaptor supplied, 1.9 lbs. **\$94.95**

**WM-1400.** Uni-directional dynamic microphone. Impedance 200 ohms. Unbalanced or balanced type changeable. With its wide frequency response, sound gathering and selectable (H) and (L) tone filter is uniquely adapted for use in theaters, auditoriums and large conference rooms for realistic voice reproduction. Provided with an ON-OFF talk switch. A 15 ft. cable with a cannon connector and a 1/4" phone plug, a stand adaptor supplied. 2.3 lbs. **\$179.95**

## 1500 SERIES PROFESSIONAL MICROPHONES

The Panasonic high quality 1500 series consists of five models: WM-1505 is best used for vocal and music pick-up; WM-1506 is a studio quality mike with a wide frequency response; WM-1520 for voice pick-up, speech and interview applications; WM-1521 for a wide range of speech applications; and the WM-1555 for studio and broadcast applications.

**WM-1505.** Uni-directional dynamic microphone. Impedance 200 ohms, balanced. Suitable for vocal and music pick-up in school music rooms and music studios. 15 ft. cable with cannon connectors, a stand adaptor provided. 1.6 lbs. **\$94.95**

**WM-1506.** Uni-directional dynamic microphone. Impedance 200 ohms, balanced. Suitable for live on-stage vocal and musical instruments pick-up. 15 ft. cable with cannon connectors, a stand adaptor provided. 1.9 lbs. **\$119.95**



WR-450

**WM-1520.** Uni-directional dynamic microphone. Impedance 200 ohms, balanced. Suitable for voice pick-up in speech or interviewing. A 15 ft. cable with cannon connectors and a stand adaptor supplied. 1.8 lbs. **\$99.95**

**WM-1521.** Uni-directional dynamic microphone. Impedance 200 ohms, balanced. With wide frequency response, suitable for crisp, clear voice pick-up in speech or interviewing. A 15 ft. cable with cannon connectors and a stand adaptor supplied. 1.8 lbs. **\$124.95**

**WM-1555.** Uni-directional dynamic microphone with wide frequency response for realistic sound reproduction. Finds its accepted place in the broadcast studio as a hand-held microphone. Impedance 250 ohms, balanced. 15 ft. cable with cannon connectors and stand adaptor supplied. 2.0 lbs. **\$299.95**

## MICROPHONE ACCESSORIES

**WN-1112P.** Desktop Stand. 1.7 lbs. **\$8.95**

**WM-C5.** Microphone extension cable, 16.5 ft. phone plug. WM-1100 Series and WM-1300 Series Microphones. 0.5 lbs. **\$9.95**

**WM-C10.** Microphone extension cable, 33 ft. phone plug. 0.8 lbs. **\$14.95**

**WM-C20.** Microphone extension cable, 66 ft. phone plug. 1.5 lbs. **\$24.95**

## AUDIO MIXER

The Panasonic WR-450 mixer is an excellent mate for Panasonic video equipment. Six sliding fader controls mix high or low level input sources, including mikes and phonographs. Each input has a low cut filter to help minimize low frequency noises. A VU meter tracks the overall volume level and a tone oscillator provides a reference signal to help set levels. WR-450 has a monitor amplifier and front panel speaker. The Monitor circuitry can also be used for studio talk back purposes.

**WR-450.** Deluxe audio mixer with six sliding fader controls mix low or high level input sources. Phono input adds RIAA equalization and can be used with mono or stereo cartridges. VU meters tracks the overall volume level. Unit has a monitor amplifier and front panel speaker. Completely solid state and fits standard 19" EIA racks. Use with all Mini-Studio Systems and Microphones. 15.4 lbs. **\$460.00**



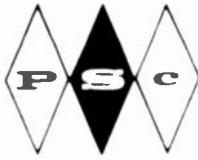

**peerless sales  
company**

## TELEVISION STANDS/ BRACKETS/CARTS/MOUNTS

### WALL SWIVEL BRACKETS



Wall swivel brackets are Peerless' answer to the space problem. Save that desk or floor space and create an uncluttered look by mounting television receivers on the wall. Various sizes, styles and configurations of wall brackets have been designed for a variety of applications. Units that swivel, units that swivel and tilt; all available in a variety of sizes. Small screen black and white receivers can be accommodated equally as well as 25" large screen color units. . . .

### PEDESTAL STANDS

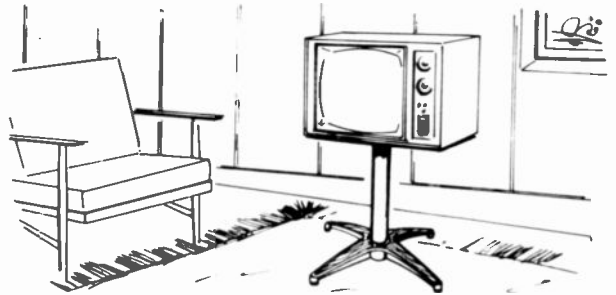

These sleek modern appearing units are built rugged enough to withstand years of abuse. Functional and attractive, these pedestals assemble easily and simply. Available in various sizes and heights to satisfy whatever the requirements may be. Some models will adapt to casters. A variety of styles insure the availability of a pedestal stand that is priced right for your application.

### FURNITURE TOP SWIVEL MOUNTS

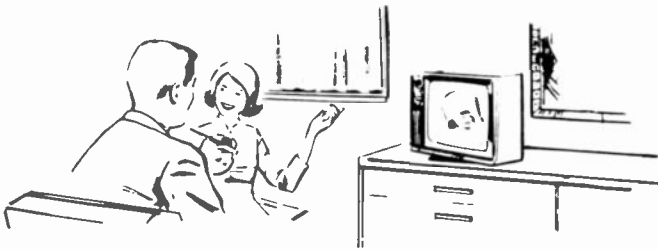

Here's an ideal way to give a Television receiver mobility yet still keep the unit tied down. The exclusive Peerless one piece swivel design enables one to swivel the T.V. at a touch of the finger. Many receivers can be secured either with a lock or tamper proof screws to give the installation the security that may be required. A variety of universal sizes to fit every T.V. receiver are available from stock.

### CEILING MOUNTS

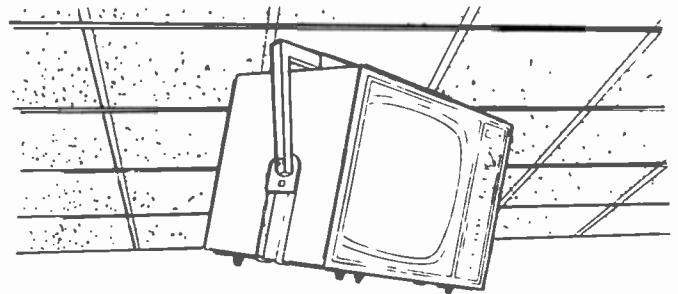

Choose from a variety of styles and types of ceiling mounts that have been designed, engineered and developed after years of actual experience in the field. One of the more unique models makes it possible to suspend up to a 25" large color set in areas where drop ceilings have been installed without having to bridge down from the slab above. Other more conventional styles of ceiling mounts are also available from stock for any size receiver.

### EDUCATIONAL T.V. CARTS



Peerless E.T.V. carts have been designed specifically to handle classroom requirements in the safest manner possible and are available from stock. These units all incorporate a flaired leg design for exceptional stability. Models to handle 25" color monitors as well as 19" B/W receivers are available. Thousands of these units being used across the country today demonstrate the acceptability of the Peerless ETV Cart Design.

### VIDEO TAPE RECORDER CARTS



Unique modular design permits purchase of V.T.R. cart components to match the equipment in your system. Start with a basic general purpose VTR cart and build it into a mini console, complete with rack mount and camera mount. Fashioned and designed with black vinyl shelves and chrome legs to compliment the most sophisticated V.T.R. components.



# LENSES

## MANUAL FIXED FOCAL LENSES

		USER
<b>2/3" FORMAT</b>		
M-J4.5T	4.5mm wide angle f2.0, no iris .....	141.00
HF5.5A	5.5mm wide angle f1.6 .....	200.00
HF9A	9mm wide angle f1.4 .....	84.00
HF16-A	16mm lens f1.4 .....	78.00
HF35-A	35mm lens f1.7 .....	73.00
<b>1" FORMAT</b>		
M6.5-T	6.5mm wide angle f1.4, .....	160.00
CF8-A	8mm wide angle f1.8 .....	300.00
CF12.5-A	12.5mm wide angle f1.4 .....	120.00
CF25-B	25mm lens f1.4 .....	99.00
CF25-L	25mm lens f0.85 .....	377.00
CF50-B	50mm lens f1.4 .....	108.00
CF50-L	50mm lens f0.7 .....	550.00
CF75-A	75mm lens f1.8 .....	120.00

## MOTORIZED IRIS FIXED FOCAL LENGTH

<b>2/3" FORMAT</b>		
TV-HF9A	9mm wide angle motorized iris f1.4 .....	320.00
TV-HF16A	16mm wide angle motorized iris f1.4 .....	320.00
TV-HF35A	35mm motorized iris f1.7 .....	320.00
<b>1" FORMAT</b>		
TV-CF12.5A	12.5mm wide angle motorized iris f1.4 .....	340.00
TV-CF25B	25mm motorized iris f1.4 .....	340.00
TV-CF50B	50mm motorized iris f1.4 .....	340.00
TV-CF75A	75mm motorized iris f1.8 .....	340.00

## MOTORIZED IRIS FIXED FOCAL LENGTH WITH N. D. SPOT FILTER

<b>2/3" FORMAT</b>		
TV-HF9A-ND	9mm motorized iris with N. D. spot filter .....	360.00
TV-HF16A-ND	16mm motorized iris with N. D. spot filter .....	360.00
TV-HF35A-ND	35mm motorized iris with N. D. spot filter .....	360.00
<b>1" FORMAT</b>		
TV-CF12.5A-ND	12.5mm motorized iris with N. D. spot filter .....	390.00
TV-CF25A-ND	25mm motorized iris with N. D. spot filter .....	390.00
TV-CF50A-ND	50mm motorized iris with N. D. spot filter .....	390.00
TV-CF75B-ND	75mm motorized iris with N. D. spot filter .....	390.00

## AUTO-IRIS FIXED FOCAL LENGTH LENSES WITH N. D. SPOT FILTER

<b>2/3" FORMAT</b>		
TV-HF9A-SND	9mm auto-iris with N. D. spot filter .....	410.00
TV-HF16A-SND	16mm auto-iris with N. D. spot filter .....	410.00
TV-HF35A-SND	35mm auto-iris with N. D. spot filter .....	410.00
<b>1" FORMAT</b>		
TV-CF12.5A-SND	12.5mm auto-iris with N. D. spot filter .....	430.00
TV-CF25B-SND	25mm auto-iris with N. D. spot filter .....	430.00
TV-CF50B-SND	50mm auto-iris with N. D. spot filter .....	430.00
TV-CF75A-SND	75mm auto-iris with N. D. spot filter .....	430.00

## MANUAL ZOOM LENSES

<b>2/3" FORMAT</b>		
M-J5F	5x zoom lens 14-70mm f2.0 .....	270.00
M-J6F	6x zoom lens 12.5-75mm f1.8 .....	330.00
M-J8C	8x zoom lens 11.5-90mm f2.1 .....	450.00
M-J8F	8x zoom lens 12.5-100mm f2.0 .....	580.00
M-J10C	10x zoom lens 11.5-110mm f2.3 .....	600.00

ALL MANUAL ZOOM LENSES AVAILABLE WITH N. D. SPOT FILTER INSTALLED 150.00



Prices and Specifications Subject to Change Without Notice.

### 1" FORMAT

M-5F	5x zoom lens 20-100mm f1.8 .....	270.00
M-6F	6x zoom lens 18-108mm f2.5 .....	270.00
M-6F-1.8	6x zoom lens 18-108mm f1.8 .....	700.00
M-6C-1.6	6x zoom lens 18-108mm f1.6 .....	830.00
M-8F	8x zoom lens 18-144mm f2.0 .....	1020.00
M-10C	10x zoom lens 15-150mm f2.8 .....	950.00
M-10F	10x zoom lens 16-160mm f2.5 .....	1130.00
M-10F-1.8	10x zoom lens 16-160mm f1.8 .....	1600.00
M-14F	14x zoom lens 25-350mm f3.5 .....	3150.00

Prices and Specifications Subject to Change Without Notice.

# LENSES



TV-J6F



TV-6F



TV-J5F



TV-10F

## MOTORIZED ZOOM LENSES

### 2/3" FORMAT

		USER
TV-J5F	5x zoom lens 14-70mm f2.0	840.00
TV-J6F	6x zoom lens 12.5-75mm f1.8	930.00
TV-J8C	8x zoom lens 11.5-90mm f2.1	1030.00
TV-J8F	8x zoom lens 12.5-100mm f2.0	1170.00
TV-J10C	10x zoom lens 11.5-110mm f2.3	1270.00

### 1" FORMAT

TV-5F	5x zoom lens 20-100mm f2.0	1040.00
TV-6F	6x zoom lens 18-108mm f2.5	690.00
TV-6T	6x zoom lens 15-90mm f1.9	920.00
TV-6F-1.8	6x zoom lens 18-108mm f1.8	1200.00
TV-6C-1.6	6x zoom lens 18-108mm f1.6	1430.00
TV-8F	8x zoom lens 18-144mm f2.0	1400.00
TV-10C	10x zoom lens 15-150mm f2.8	1550.00
TV-10F	10x zoom lens 18-160mm f2.5	1820.00
TV-10F 1.8	10x zoom lens 18-160mm f1.8	2550.00
TV-14F	14x zoom lens 25-350mm f3.5	4400.00

### N. D. SPOT FILTER AVAILABLE FOR ALL MOTORIZED ZOOM LENSES

150.00

### CABLE DRIVE ZOOM LENSES (SPECIFY CAMERA)

#### 1" FORMAT

C5 x 20RW-2	20-100mm f1.8	1110.00
C8 x 18RW-2	18-144mm f2.0	1490.00
C10 x 16RW-2	16-160mm f2.5	1790.00

#### 2/3" FORMAT

H6 x 12.5HW-1	12.5-75mm f1.8	690.00
H10 x 11HW-1	11-110mm f2.5	1150.00

### PUSH ROD ZOOM LENSES (SPECIFY CAMERA)

#### 2/3" FORMAT

H5x14HP-2	14-70mm f2.0 . . . . 70mm pushrod	480.00
H8x12.5HP-2	12.5-100mm f2.0 . . . . 70mm pushrod	870.00
H10x11HP-2	11-110mm f2.5 . . . . 70mm pushrod	1050.00

#### 1" FORMAT

C10x16BHP-2	16-160mm f2.5 . . . . 70mm pushrod	1550.00
-------------	------------------------------------	---------

### RADIATION RESISTANT LENSES

#### 1" FORMAT

TV-5L-RAD	30-150mm f2.7 motorized zoom	2400.00
CF12.5N	12.5mm fixed focal length f2.0	720.00
CF25N	25mm fixed focal length f2.0	600.00
CF50N	50mm fixed focal length f2.0	640.00

### EXTENDERS FOR 2/3" AND 1" FORMATS

F1.5x	1.5x range extender	110.00
F-2x	2x range extender	110.00

### OPTIONS

AZL	Position feedback modification available most models	135/Pos.
LPS-1	12VDC power supply for auto-iris lenses	60.00



# PAN & TILTS

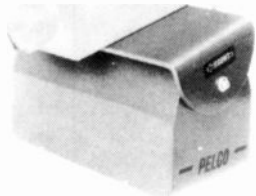

PT-250

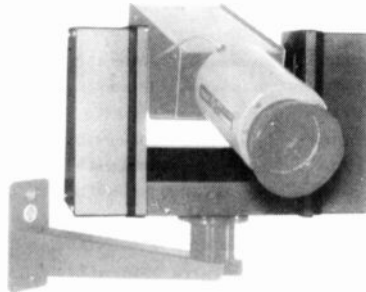

PT-77



PT-550-M



PT-155-S

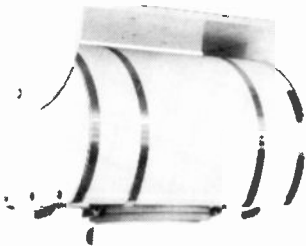

PT-1050-L



PS-5

PT-250-P	"Mini" light duty pan/tilt 115 vac operation for loads up to 20 lbs. Use MPT-25 joystick control	360.00
PT-250-24P	"Mini" light duty pan/tilt 24 vac operation for loads up to 20 lbs. Use MPT-2524 joystick control	360.00
PT-77	Silent light duty pan/tilt 115 vac operation for loads up to 20 lbs. Use MPT-1577 joystick control	540.00
PT-77-24	Silent light duty pan/tilt 24 vac operation for loads up to 20 lbs. Use MPT-1524 joystick control	540.00
PT-155-P	Medium duty pan/tilt 115 vdc operation for loads up to 40 lbs. Use MPT-1500 joystick control	540.00
PT175-P	Medium duty pan/tilt 115 vac operation for loads up to 40 lbs. Use MPT-115 joystick control	540.00
PT-175-24P	Medium duty pan/tilt 24 vac operation for loads up to 40 lbs. Use MPT-24 joystick control	540.00

## OUTDOOR PAN AND TILTS

PT-550-P	Medium duty pan/tilt 115 vdc operation for loads up to 40 lbs. Use MPT-1500 joystick control	660.00
PT-570-P	Medium duty pan/tilt 115 vac operation for loads up to 40 lbs. Use MPT-115 joystick control	660.00
PT-570-24P	Medium duty pan/tilt 24 vac operation for loads up to 40 lbs. Use MPT-24 joystick control	660.00
PT-1050-L	Heavy duty pan/tilt 115 vdc operation for loads up to 90 lbs. Use MPT-1500 joystick control	1100.00
PT-1250-P	Heavy duty pan/tilt 115 vac operation for loads up to 100 lbs. Use MPT-115 joystick control	1100.00
PT-1250-24P	Heavy duty pan/tilt 24 vac operation for loads up to 100 lbs. Use MPT-24 joystick control	1100.00
PT-2000-L	Extra heavy duty, 115 vdc operation for loads up to 150 lbs. Use MPT-2000 joystick control	2000.00

## EXPLOSION PROOF PAN AND TILTS

PT-550-PX	Explosion proof per MIL-E-5272C & MIL-STD810B specification and procedures. 115 vdc operation for loads up to 40 lbs. Use MPT-1500 joystick control	740.00
PT-1050-LX	Explosion proof per MIL-E-5272C & MIL-STD810B specifications and procedures. 115 vdc operation for loads up to 90 lbs. Use MPT-1500 joystick control	1500.00
PT-1250-EX	Explosion proof per N.E.C. Class I, Div. I, Groups C & D, Class II, Div. I, Groups E, F, G, 115 vac operation for loads up to 100 lbs. Use MPT-115 joystick control	1600.00
PT-1250-24EX	Explosion proof per N.E.C. Class I, Div. I, Groups C & D, Class II, Div. I, Groups E, F, G, 24 vac operation for loads up to 100 lbs. Use MPT-24 joystick control	1600.00

## ANTENNA POSITIONER

AP-2500	Antenna positioning system for antennas up to 6 foot in diameter. Complete with control, which includes joystick, variable speed, digital read out meters	5000.00
---------	---	---------

## UNDER WATER PAN AND TILTS

PT-1000-UW	Under water pan/tilt 115 vdc operation for depths up to 500'. Use MPT-1500 joystick control	5000.00
------------	--	---------

## OPTIONS AND ACCESSORIES

/PP	Preset position modification (Available most models)	200.00
/AZL	Position read out modification (Available most models)	200.00
/SEC	Sector scan modification for PT1050L, PT1050LX, PT1250P, PT1250-24P	150.00
/RAD	Radiation wiring and white epoxy paint for PT1050L, PT-550P	200.00
/HB	Spot and blanket heaters for PT550P, PT570P, PT570-24P, PT1050L, PT1250P, PT1250-24P, PT2000L. Allows operation to -50°F (-45°C)	150.00
/FG	Special hi speed gears (Per function)	80.00

# SCANNERS

## INDOOR SCANNERS

PS-5	"Mini" light duty scanners, 115 vac operation for loads up to 20 lbs. Furnished with 6 ft. line cord for auto-scan operation, only	130.00
PS-5A	Same as PS-5 except operates with a MPS-5 control	130.00
PS-5-24	Same as PS-5A except operates on 24 vac. Use MPS-524 control	130.00

## OUTDOOR SCANNERS

PS-20	Medium duty outdoor 115 vac operation for loads up to 30 lbs. Furnished with 6 ft. line cord for auto-scan operation, only	300.00
PS-20A	Medium duty outdoor scanner 115 vac operation for loads up to 30 lbs. Use MPS control	300.00
PS-20-24	Medium duty outdoor scanner 24 vac operation for loads up to 30 lbs. Use MPS-24 control	300.00

Prices and Specifications Subject to Change Without Notice.

Prices and Specifications Subject to Change Without Notice.

# CAMERA ENCLOSURES



## INDOOR ENCLOSURES

EHTP-2	Indoor tamper proof. Mounting bracket included. Specify wall or ceiling. ....	80.00 60.00
EH-44	Indoor tamper proof for small 2/3" cameras with auto iris .....	

## OUTDOOR ENCLOSURES

EH-55	Environment enclosure with sun shroud (5 1/2" W x 5" H x 15" L) .....	130.00
<b>EH-55 ACCESSORIES</b>		
B-55	Blower with thermostat control .....	40.00
H-55	Heater with thermostat control .....	40.00
L-55	Tamper proof locks .....	38.00
EH-66	Environmental Enclosure (9" W x 8" H x 25" L) .....	190.00
EH-66X	Extra Long Environmental Enclosure (9" W x 8" H x 36" L) .....	260.00
<b>EH-66, EH-66X ACCESSORIES</b>		
B-66	Blower with thermostat control .....	50.00
H-66	Heater with thermostat control .....	40.00
S-66	Sun Shroud .....	40.00
L-66	Tamper proof locks .....	30.00
EH-1	Environmental Enclosure (12" W x 10" H x 22" L) .....	220.00
EH-2	Environmental Enclosure (12" W x 10" H x 28" L) .....	240.00
EH-2X	Environmental Enclosure (12" W x 10" H x 34" L) .....	270.00
<b>EH-1, EH-2, EH-2X ACCESSORIES</b>		
EH-C	Mounting Cradle .....	Inc.
EH-TI	Thermal Insulation .....	20.00
EH-B	Blower and thermostat control .....	80.00
EH-H	Heater and thermostat control .....	60.00
EH-WD	Window defroster used with EH-H .....	50.00
EH-WO	Windshield wiper outside blade .....	50.00
EH-WIO	Windshield wiper inside/outside .....	70.00
EH-WW	Windshield washer .....	80.00
EH-L	Tamper proof locks .....	60.00
S-1	Sun Shroud for EH-1 .....	50.00
S-2	Sun Shroud for EH-2 .....	60.00
S-2X	Sun Shroud for EH-2X .....	70.00
EH-RC	Relay module for low voltage control (MEH24 control) .....	60.00



EHTP-2

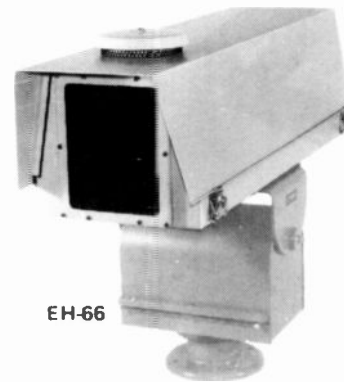

EH-66

## EXPLOSION PROOF ENCLOSURES

(Per N.E.C. Class I, Div. I, Groups C,D, Class II, Div. I, Groups E,F,G.)

EHX-6	Explosion proof enclosures (6" I. D. x 24" L) .....	530.00
EHX-8	Explosion proof enclosures (8" I. D. x 24" L) .....	570.00
EHX-10	Explosion proof enclosures (10" I. D. x 24" L) .....	610.00
EHX-12	Explosion proof enclosures (12" I. D. x 24" L) .....	650.00
EHX-S	Sun Shroud - Specify Model .....	60.00
EHX-V	Visor - Specify model .....	20.00
EH-H	Heater and thermostat control .....	60.00
	Special length per 6" increments .....	80.00

## DUST TIGHT WEATHERPROOF ENCLOSURES

EHD-724	Dust tight enclosure (7" I. D. x 24" L) aluminum .....	270.00
EHD-824	Dust tight enclosure (8" I. D. x 24" L) aluminum .....	290.00
EHD-924	Dust tight enclosure (9" I. D. x 24" L) aluminum .....	330.00
EHD-1024	Dust tight enclosure (10" I. D. x 24" L) aluminum .....	360.00
EHD-SS-724	Dust tight enclosure (7" I. D. x 24" L) stainless steel .....	360.00
EHD-SS-824	Dust tight enclosure (8" I. D. x 24" L) stainless steel .....	390.00
EHD-SS-924	Dust tight enclosure (9" I. D. x 24" L) stainless steel .....	410.00
EHD-SS-1024	Dust tight enclosure (10" I. D. x 24" L) stainless steel .....	430.00
<b>EHD ACCESSORIES</b>		
EHD-AF	Air funnel - Specify model .....	100.00
EHD-V	Visor - Specify model .....	20.00
EHD-P	Purge fittings - Specify model .....	30.00
EHD-S	Sun Shroud - Specify model .....	60.00
EH-H	Heater with thermostat .....	60.00
	Special length per 6" increments .....	80.00

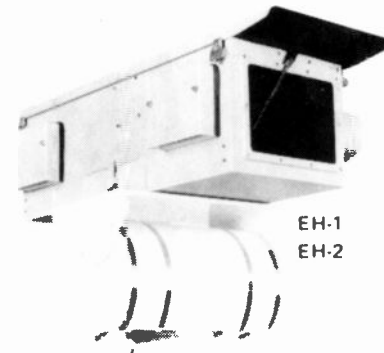

EH-1  
EH-2

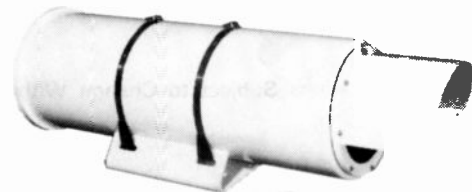

EHD

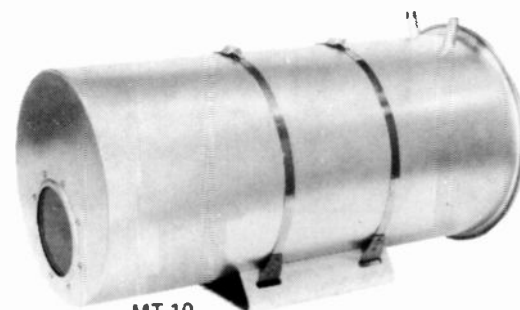

MT-10

## WATER COOLED ENCLOSURES

MT-10	Medium temperature enclosure with Pyrex glass .....	660.00
HT-10P	High temperature enclosure with Pyrex glass .....	900.00
HT-10V	High temperature enclosure with Vicor glass .....	990.00
<b>ACCESSORIES</b>		
WC-RC	Reflective coating for Pyrex or Vicor glass .....	90.00
WC-AF	Air funnel for water cooled housings .....	150.00
	Pyrex glass (4 11/16" Dia.) .....	20.00
	Vicor glass (4 11/16" Dia.) .....	160.00
WC-AL	Alarm thermostat, contact closure upon temperature rise .....	40.00

## UNDER WATER ENCLOSURES (for depths up to 500')

UW-6	Under water enclosure (6" I. D. x 24" L) .....	960.00
UW-8	Under water enclosure (8" I. D. x 24" L) .....	990.00
UW-10	Under water enclosure (10" I. D. x 24" L) .....	1200.00
<b>UNDER WATER ACCESSORIES</b>		
UW-NB	Non-Browning glass .....	Quote

## MISCELLANEOUS ACCESSORIES

EH-CM	Cradle mount for EH-66, EH-1, EH-2, EH-2X (Inverted Use) .....	50.00
EH-DP	Duplex outlet for EH-66, EH-1, EH-2, EH-2X .....	15.00



# MOUNTS

## CAMERA MOUNTS

CM-11	Light Duty Wall Mount with security ball swivel (STD carton - 6 pieces) . . . Not Sold Individually	16.00 ea.
CM-22	Medium Duty Wall Mount with security ball swivel	27.00
CM-U	Universal Wall Mount	50.00
UM-1	Universal Wall or Ceiling Mount	50.00
SF-1	Swivel Bracket . . . For UM-1	10.00
CM101C	Heavy Duty Ceiling or Pedestal Mount	60.00
CM101W	Heavy Duty Wall Mount	60.00
	Additional Length per foot, CM101W, CM101C	10.00
AD-200	Inverted Camera Adapter	10.00

## ENCLOSURE MOUNTS

EM-22	Medium Duty Wall Mount for EH-44, EH-55, EH-66	30.00
MM103C	Heavy Duty Ceiling or Pedestal Mount	50.00
EM102W	Heavy Duty Wall Mount	66.00
	ST-1 Optional Strut for EM102W	30.00
	Additional Length per foot, MM103C, EM102W	10.00

## PAN AND TILT MOUNTS

PM 200W	Wall Mount for PT-250P, PS-5	20.00
PM 200C	Ceiling or Pedestal Mount for PT-250P	20.00
PM 105	Wall Mount for PT-77, PT155P, etc.	30.00
PM 109	Wall Mount for PT-550-P, etc.	30.00
PM102C	Ceiling or Pedestal Mount for PT-550-P, etc.	40.00
PM102W	Wall Mount for PT-550-P, etc.	50.00
	PM102A Adapter Plate, adapt PT-77, PT155P	
	PM102C, PM102W	10.00
	ST-1 Optional Strut for PM102C, PM102W	30.00
PM1000C	Ceiling or Pedestal Mount for PT1050L, PT2000L, PT1250P (ST-1 Strut Included)	70.00
PM1000W	Wall Mount for PT2000L, PT1250P (ST-1 Strut Included)	80.00
	Additional Length per foot	10.00

## MONITOR MOUNTS

MR-U	Universal Monitor Mounts	100.00
MRP-1	Pan for above (32"W x 16 1/8"D)	Inc.
MRP-3	Pan for above (26"W x 12 1/4" D)	Inc.
MRP-4	Pan for above (20"W x 16" D)	Inc.
	Special sizes available upon request	Quote
MR-WA	Wall adapter for MR Series	30.00
MR-CA	Ceiling adapter for MR Series	15.00



UM-1

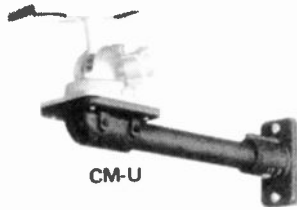

CM-U



EM-22

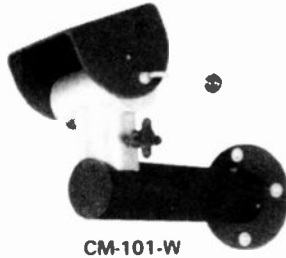

CM-101-W



MM-103-C

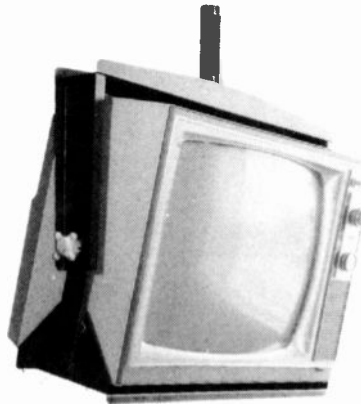

MR-U/MRP



PM-1000-W

Prices and Specifications Subject to Change Without Notice.

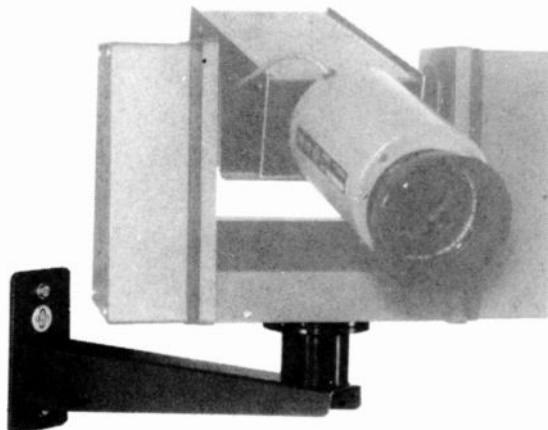

PM-105

# CROMEDOME ENCLOSURES

## INNER-SPHERE CROMEDOME

14" OUTER DOME 13-3/4" INNER DOME

IS-2	Passive Dome with fixed Camera Mount, CDM-1 (Camera & Lens up to 13 1/4")	300.00
IS-2-5	Dome with PS-5 Scanner	400.00
IS-2-5AM	Dome with PS-5A Scanner & MPS-5 Control	460.00
IS-2-5ADT	Dome with PS-5A Scanner & MPS-5DT Control	470.00
IS-2-524M	Dome with PS-524 Scanner & MPS-524 Control	470.00
IS-2-524DT	Dome with PS-524 Scanner & MPS-524DT Control	490.00

22" OUTER DOME 21-1/2" INNER DOME

IS-3-250M	Dome with PT250P Pan/Tilt & MPT25 Control & PM-200C Mount	830.00
IS-3-250DT	Dome with PT250P Pan/Tilt & MPT25-DT Control & PM-200C Mount	870.00
IS-3-24M	Dome with PT250-24P Pan/Tilt & MPT2524 Control & PM-200C Mount	830.00
IS-3-24DT	Dome with PT250-24P Pan/Tilt & MPT2524-DT Control & PM-200C Mount	870.00

## CROMEDOMES

### FIXED CAMERA DOMES

CD-12	Accepts Cameras & Lens up to 12-1/4" Long w/Mount, CDM-1	200.00
CD-14	Accepts Cameras & Lens up to 14" Long w/Mount, CDM-1	220.00
CD-18	Accepts Cameras & Lens up to 19" Long w/Mount, CDM-2	230.00

### SCANNER DOMES

CD-14S	Accepts PS-5 Scanners and Cameras & Lens up to 16" Long	200.00
--------	---	--------

### PAN/TILT DOMES

CD18P	Accepts PT250P and Camera/Lens up to 16-1/2" Long	220.00
CD22P	Accepts PT155P and Camera/Lens up to 17" Long	330.00
CD26P	Accepts Pan/Tilts 13" High & Camera/Lens 23" Long	420.00

# VIDEO SWITCHERS SEQUENTIAL VERTICAL INTERVAL



## HOMING SEQUENTIAL SWITCHERS (Single Output) \*\*

VS504H	4 Position Homing Sequential Switcher	230.00
VS506H	6 Position Homing Sequential Switcher	290.00
VS508H	8 Position Homing Sequential Switcher	330.00
VS510H	10 Position Homing Sequential Switcher	360.00
VS512H	12 Position Homing Sequential Switcher	390.00
VS514H	14 Position Homing Sequential Switcher	430.00
VS516H	16 Position Homing Sequential Switcher	470.00
VS518H	18 Position Homing Sequential Switcher	510.00
VS520H	20 Position Homing Sequential Switcher	550.00
VS524-40H	24-40 Position Homing Sequential Switcher* (Increments of 4)	50/pos.

## HOMING LOOPING SEQUENTIAL SWITCHERS \*\*

VS504HL	4 Position Looping Input Homing Sequential Switcher	270.00
VS506HL	6 Position Looping Input Homing Sequential Switcher	320.00
VS508HL	8 Position Looping Input Homing Sequential Switcher	370.00
VS510HL	10 Position Looping Input Homing Sequential Switcher	420.00
VS512HL	12 Position Looping Input Homing Sequential Switcher	470.00
VS514HL	14 Position Looping Input Sequential Switcher	520.00
VS516HL	16 Position Looping Input Sequential Switcher	570.00
VS518HL	18 Position Looping Input Sequential Switcher	620.00
VS520HL	20 Position Looping Input Sequential Switcher	670.00
VS524-40HL	24-40 Position Looping Input Homing Sequential Switcher* (Increments of 4)	50/pos.

## BRIDGING SEQUENTIAL SWITCHERS (dual output) \*\*

VS504B	4 Position Bridging Sequential Switcher	250.00
VS506B	6 Position Bridging Sequential Switcher	320.00
VS508B	8 Position Bridging Sequential Switcher	360.00
VS510B	10 Position Bridging Sequential Switcher	380.00
VS512B	12 Position Bridging Sequential Switcher	410.00
VS514B	14 Position Bridging Sequential Switcher	450.00
VS516B	16 Position Bridging Sequential Switcher	500.00
VS518B	18 Position Bridging Sequential Switcher	550.00
VS520B	20 Position Bridging Sequential Switcher	600.00
VS524-40B	24-40 Position Bridging Sequential Switcher* (Increments of 4)	50/pos.

## BRIDGING LOOPING SEQUENTIAL SWITCHERS \*\*

VS504BL	4 Position Looping Input Bridging Sequential Switcher	290.00
VS506BL	6 Position Looping Input Bridging Sequential Switcher	340.00
VS508BL	8 Position Looping Input Bridging Sequential Switcher	390.00
VS510BL	10 Position Looping Input Bridging Sequential Switcher	440.00
VS512BL	12 Position Looping Input Bridging Sequential Switcher	490.00
VS514BL	14 Position Looping Input Bridging Sequential Switcher	540.00
VS516BL	16 Position Looping Input Bridging Sequential Switcher	590.00
VS518BL	18 Position Looping Input Bridging Sequential Switcher	640.00
VS520BL	20 Position Looping Input Bridging Sequential Switcher	690.00
VS524-40BL	24-40 Position Looping Input Bridging Sequential Switcher (Increments of 4)	60/pos.

## VID-ALARM SEQUENTIAL SWITCHERS \*\*

VA504	4 Position Vid-Alarm Sequential Switcher	440.00
VA506	6 Position Vid-Alarm Sequential Switcher	490.00
VA508	8 Position Vid-Alarm Sequential Switcher	540.00
VA510	10 Position Vid-Alarm Sequential Switcher	590.00
VA512	12 Position Vid-Alarm Sequential Switcher	640.00
VA514-20	14-20 Position Vid-Alarm Sequential Switcher	60/pos.
VA524-40	24-40 Position Vid-Alarm Sequential Switcher* (Increments of 4)	70/pos.

## VID-ALARM LOOPING SEQUENTIAL SWITCHERS \*\*

VA504L	4 Position Looping Input Vid-Alarm Switcher	480.00
VA506L	6 Position Looping Input Vid-Alarm Switcher	530.00
VA508L	8 Position Looping Input Vid-Alarm Switcher	580.00
VA510L	10 Position Looping Input Vid-Alarm Switcher	630.00
VA512L	12 Position Looping Input Vid-Alarm Switcher	680.00
VA514-20L	14-20 Position Looping Input Vid-Alarm Switcher	70/pos.
VA524-540L	24-40 Position Looping Input Vid-Alarm Switcher* (Increments of 4)	80/pos.

## OPTIONS FOR SEQUENTIAL SWITCHERS

/X	External Trigger Option	50.00
/CD	Digital Camera Display Option	30/pos.
	Available for Homing, Homing Looping Sequential Switchers	
/AMP	Output amplifier for monitor 2 output.	30/pos.
	For use with VTR'S or monitors which must be terminated.	

\*\* On all switchers specify Rack Mount or Desk Top Cabinet.

No additional charges, i. e., VS504HR, VS504HDT

\* All switchers over 20 positions occupy 3 1/2" panel height.

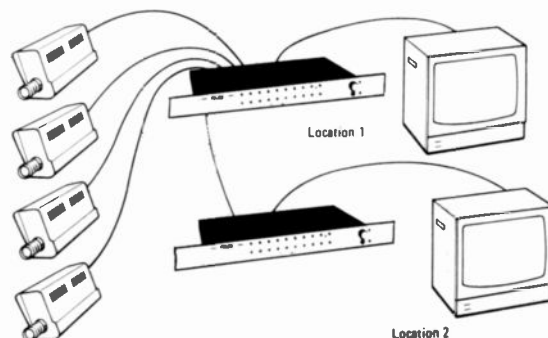

Up to 10 cameras depending on model

## HOMING LOOPING SEQUENTIAL SWITCHERS

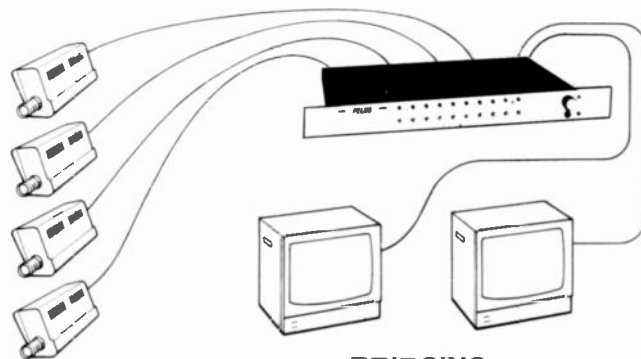

Up to 10 cameras depending on model

## BRIDGING SEQUENTIAL SWITCHERS

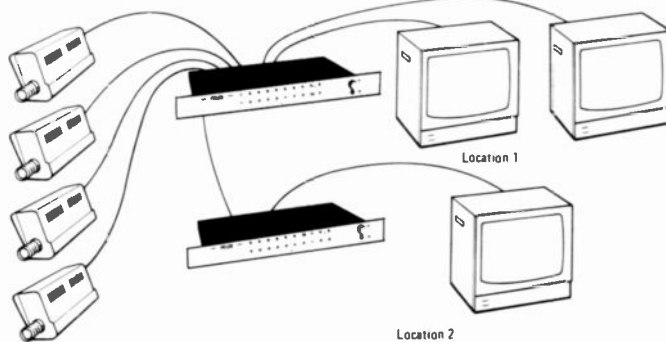

Up to 10 cameras depending on model

## BRIDGING LOOPING SEQUENTIAL SWITCHERS

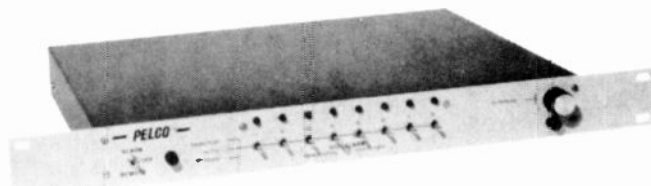

## VID-ALARM SEQUENTIAL SWITCHERS



# VIDEO SWITCHERS MANUAL

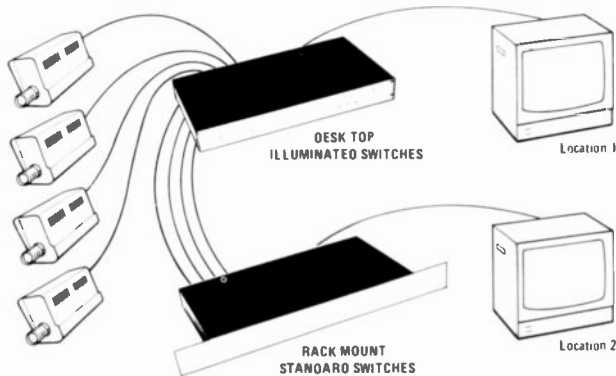
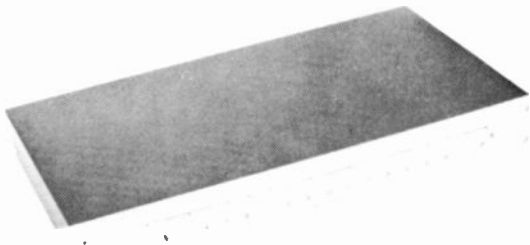
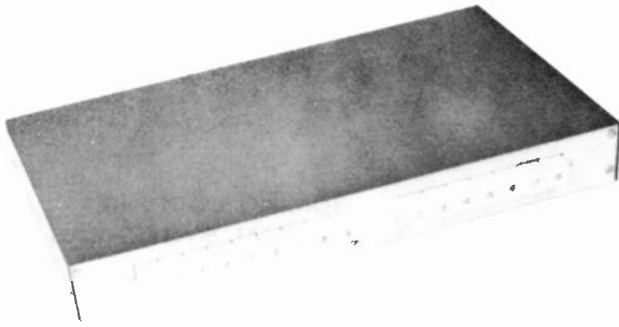

## MANUAL PASSIVE SWITCHERS \*\*

MS504	4 Position Passive Switcher	60.00
MS506	6 Position Passive Switcher	100.00
MS508	8 Position Passive Switcher	110.00
MS510	10 Position Passive Switcher	130.00
MS512	12 Position Passive Switcher	140.00
MS514	14 Position Passive Switcher	170.00
MS516	16 Position Passive Switcher	200.00
MS518	18 Position Passive Switcher	240.00
MS520	20 Position Passive Switcher *	290.00
MS524-540	24 - 40 Position Passive Switcher * (Increments of 4)	20/pos.

## ILLUMINATED MANUAL PASSIVE SWITCHERS \*\*

MS504G	4 Position illuminated passive switcher	110.00
MS506G	6 Position illuminated passive switcher	130.00
MS508G	8 Position illuminated passive switcher	150.00
MS510G	10 Position illuminated passive switcher	170.00
MS512G	12 Position illuminated passive switcher	190.00
MS514G	14 Position illuminated passive switcher	210.00
MS516G	16 Position illuminated passive switcher	240.00
MS518G	18 Position illuminated passive switcher	290.00
MS520G	20 Position illuminated passive switcher *	320.00
MS524-540G	24 - 40 Position illuminated switcher * (Increments of 4)	20/pos.

## MANUAL LOOPING INPUT SWITCHERS \*\*

MS504L	4 Position Looping input switcher	90.00
MS506L	6 Position Looping input switcher	110.00
MS508L	8 Position Looping input switcher	130.00
MS510L	10 Position Looping input switcher	150.00
MS512L	12 Position Looping input switcher	170.00
MS514L	14 Position Looping input switcher	210.00
MS516L	16 Position Looping input switcher	240.00
MS518L	18 Position Looping input switcher	290.00
MS520L	20 Position Looping input switcher *	320.00
MS524-540L	24 - 40 Position Looping input switcher * (Increments of 4)	20/pos.

## ILLUMINATED MANUAL LOOPING INPUT SWITCHERS\*\*

MS504GL	4 Position illuminated looping input switcher	120.00
MS506GL	6 Position illuminated looping input switcher	150.00
MS508GL	8 Position illuminated looping input switcher	170.00
MS510GL	10 Position illuminated looping input switcher	190.00
MS512GL	12 Position illuminated looping input switcher	210.00
MS514GL	14 Position illuminated looping input switcher	250.00
MS516GL	16 Position illuminated looping input switcher	300.00
MS518GL	18 Position illuminated looping input switcher	340.00
MS520GL	20 Position illuminated looping input switcher *	390.00
MS524-540GL	24-40 Position illuminated looping input switcher * (Increments of 4)	30/pos.

## OPTIONS

/AF	Audio follow for non-illuminated passive switchers up to 18 positions. SPST normally open switch closure for each position.	12/pos.
	For illuminated passive switchers up to 18 positions.	20/pos.
/BAF	Balanced audio follow for non-illuminated passive switchers up to 18 positions. DPDT normally open switch closures for each switch	25/pos.
/AMP	Output amplifier for looping manual switchers. For use with VTR'S or monitors which must be terminated	30.00

\*\* On all switchers specify Rack Mount or Desk Top Mounting. No additional charges, i.e., MS504DT, MS504R  
\* All switchers over 18 positions occupy 3 1/2" panel height.



# CONTROLS MEDIUM DISTANCE



**A LOW VOLTAGE REMOTE CONTROL SYSTEM FOR CONTROL UP TO 10,000 FEET ON 20 AWG CABLE FEATURING:**

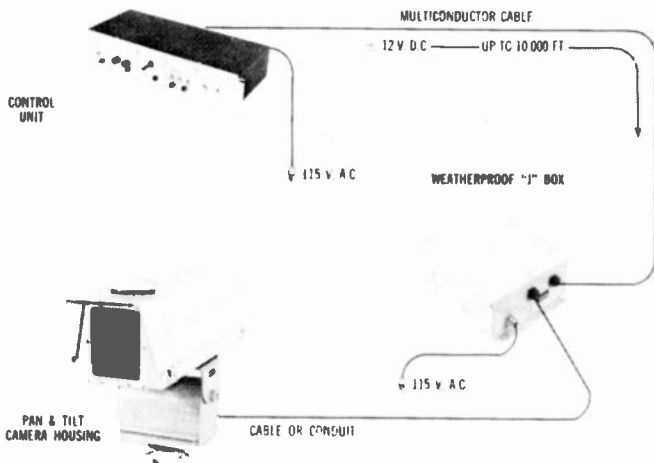

- OPERATES UP TO 20 MILES OVER A BALANCED TWISTED PAIR, VOICE GRADE TELEPHONE LINE, MICRO WAVE, OR AN RF LINK
- CONTROL UP TO 32 DIFFERENT LOCATIONS FROM 1 CONTROL PANEL
- ORIGINATES UP TO 24 SEPERATE OR SIMULTANEOUS FUNCTIONS PER LOCATION
- SIGNAL PARITY CHECK
- DUAL SCAN PROTECTION



## ELECTRONIC 7000

### PANELS AND DESK TOP CABINETS

M5C-P	Rack Mount for up to 5 Modules 1 3/4" x 19"	50.00
M5C-DT	Desk Top Cabinet for up to 5 Modules	50.00

### CONTROL MODULES

MAD7000	Address Module up to 9 Locations	100.00
MPT7000	Pan/Tilt Joystick Control Module	90.00
VR7000	Variable Rate Joystick Control Module (3 1/2" Panel Height)	300.00
MA7000	Autoscan Control Module	30.00
MV7000	Variable Speed Control Module	60.00
MLZ7000	Pelco Lens Control Module	60.00
MAI7000	Auto-Iris Zoom Lens Control Module	90.00
MEH7000	Enclosure Control Module	60.00
	Camera On/Off Wiper/Washer	
M7000DS-1	Dual Station Control Module Station 1	60.00
M7000DS-2	Dual Station Control Module Station 2	130.00
MG7000	Gate Control Module (Open, Close, Stop)	60.00
MCCU7000	Customer Camera Control Module (i.e. Beam, target, focus)	Quotation

### JUNCTION BOX SUPPLY OPTIONS

PT 7000-J	Pan/Tilt Power Supply in a weatherproof Junction Box	380.00
AD7000-PS	Address Power Supply	150.00
A7000-PS	Auto Scan Supply	60.00
V7000-PS	Variable Speed Supply	90.00
LZ7000-PS	Pelco Lens Supply	90.00
AI7000-PS	Auto-Iris Zoom Lens Supply	280.00
EH7000-PS	Enclosure Supply	90.00
G7000-PS	Gate Power Supply	90.00
CCU7000-PS	Custom Camera Control Power Supply	Quotation

Note: When using VR7000 order both PT7000-J and V7000-PS.

# LONG DISTANCE

## DIGITAL MULTIPLEXOR

### PANELS AND DESK TOP CABINETS

M5C-P	Rack Panel for up to 5 Modules 1-3/4" x 19"	50.00
M5C-DT	Desk Top Cabinet for up to 5 Modules	50.00

### CONTROL MODULES

MAD3200	Address Module for up to 32 Locations	60.00
MPT3200	Pan/Tilt Joystick Control Module	60.00
MA3200	Autoscan Control Module	60.00
MV3200	Variable Speed Control Module	60.00
MLZ3200	Pelco Lens Control Module	60.00
MAI3200	Auto-Iris Zoom Lens Control Module	90.00
MEH3200	Enclosure Control Module	60.00
	(Camera On/Off Wiper/Washer)	
MG3200	Gate Control Module (Open, Close, Stop)	60.00
MCCU3200	Custom Camera Control Module (i.e. Beam, Target, Focus)	Quotation

### DIGITAL TRANSMITTER

DM3200-TX	Digital Multiplexor Transmitter	750.00
-----------	---------------------------------	--------

### DIGITAL RECEIVER

OM3224-RX	Digital Multiplexor - up to 24 Junction Receiver	1150.00
-----------	--	---------

### POWER SUPPLIES FOR RECEIVERS

PT3200-PS	Pan/Tilt Power Supply	150.00
A3200-PS	Autoscan Power Supply	150.00
V3200-PS	Variable Speed Power Supply	270.00
LZ3200-PS	Pelco Lens Power Supply	130.00
AI3200-PS	Auto-Iris Zoom Lens Power Supply	280.00
EH3200-PS	Enclosure Power Supply	120.00
G3200-PS	Gate Power Supply	120.00
CCU3200-PS	Custom Camera Power Supply	Quotation

Prices and Specifications Subject to Change Without Notice.

# CONTROLS SHORT DISTANCE

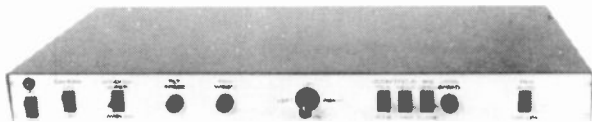
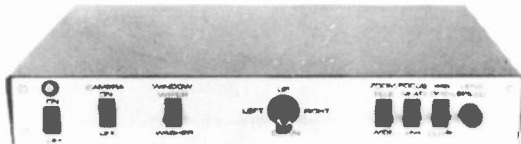
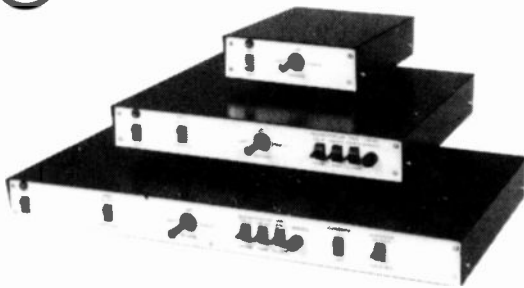

## PANELS AND DESK TOP CABINETS

M5C-P	Rack Mount for up to 5 Modules 1-3/4" x 19"	50.00
M3C-DT	Desk Top Cabinet for up to 3 Modules	50.00
M5C-DT	Desk Top Cabinet for up to 5 Modules	50.00

## PAN & TILT CONTROLS:

### FOR PT-250P PAN/TILT

MPT25-DT	Desk Top Joystick Control	130.00
MPT25	Joystick Control Module	90.00
MA25	Auto Scan Control Module	70.00

### FOR PT-250-24P PAN/TILT

MPT2524-DT	Desk Top Joystick Control	130.00
MPT2524	Joystick Control Module	90.00
MA2524	Auto Scan Control Module	70.00

### FOR PT-77-24 PAN/TILTS

MPT1524-DT	Desk Top Joystick Control	130.00
MPT1524	Joystick Control Module	90.00
MA1524	Auto Scan Control Module	70.00

### FOR PT-77 PAN/TILTS

MPT1577-DT	Desk Top Joystick Control	130.00
MPT1577	Joystick Control Module	90.00
MA1577	Auto Scan Control Module	70.00

### FOR PT175-24P, PT570-24P, PT1250-24P PAN/TILTS

MPT24-DT	Desk Top Joystick Control	130.00
MPT24	Joystick Control Module	90.00
MA24	Auto Scan Control Module	70.00

### FOR PT175P, PT570P, PT1250P PAN/TILTS

MPT115-DT	Desk Top Joystick Control	130.00
MPT115	Joystick Control Module	90.00
MA115	Auto Scan Control Module	70.00

### FOR PT-155P, PT-550P, PT-1050L PAN/TILTS

MPT1500-DT	Desk Top Joystick Control	130.00
MPT1500	Joystick Control Module	90.00
MA1500	Auto Scan Control Module	90.00
MV1500	Variable Speed Control Module	70.00
VR1500-M	Variable Rate Joystick Control (occupies 3-1/2" Panel Height)	210.00

### FOR PT-2000L PAN/TILT

MPT2000-DT	Desk Top Joystick Control	130.00
MPT2000	Joystick Control Module	90.00
MV2000	Variable Speed Control Module	95.00

## SCANNER CONTROLS

MPS5	Scanner Control Module for PS-5A	60.00
MPS5-DT	Desk Top Scanner Control for PS-5A	70.00
MPS524	Scanner Control Module for PS-5-24	70.00
MPS524-DT	Desk Top Scanner Control for PS-5-24	80.00
MPS	Scanner Control Module for PS-20-A	70.00
MPS-DT	Desk Top Scanner Control for PS-20-A	80.00
MPS24	Scanner Control Module for PS-20-24	80.00
MPS24-DT	Desk Top Scanner Control for PS-20-24	90.00

## MULTIPLE LOCATION SCANNER CONTROL

PS506	Scanner Control for up to 6 scanners, 115vac operation for PS-5A scanner, specify rack mount or desk top.	320.00
PS506-24	Scanner control for up to 6 scanners, 24vac operation for PS524 scanner	400.00
PS506V	Same as PS506 except allows for video follow control selection	400.00
PS506V-24	Same as PS506-24 except allows for video follow control selection	490.00

## LENS CONTROLS FOR PELCO MOTORIZED ZOOM LENSES

MLZ5	Zoom Lens Control Module	120.00
MLZ5-DT	Desk Top Zoom Lens Control	140.00
MLZA5	Auto Iris Zoom Lens Control Module	300.00
MLZA5-DT	Desk Top Auto-Iris Zoom Lens Control	330.00

## ENCLOSURE CONTROLS

MEH	Enclosure Control Module 115vac Camera On/Off Windshield Wiper/Washer	40.00
MEH24	Enclosure Control Module 24vac (Requires EH-RC in Housing) Camera On/Off Windshield Wiper/Washer	60.00
MEH-DT	Enclosure Control Desk Top 115vac Camera On/Off Windshield Wiper/Washer	60.00
MEH24-DT	Enclosure Control Desk Top 24vac Camera On/Off Windshield Wiper/Washer	70.00

Prices and Specifications Subject to Change Without Notice.

## DUAL STATION CONTROLS

Requires the addition of the components listed below.  
For any control series:

M1000S	Dual Station Control Modules One required for each Control Panel	60.00
DS100-J	Dual Station Junction Box One required per system	100.00

## MISCELLANEOUS CONTROLS

AZL 176	Position Indication Meters used with AZL option in P/T	200.00
------------	--	--------

### ELECTRONIC FIELD PRODUCTION 3 CHART SYSTEM

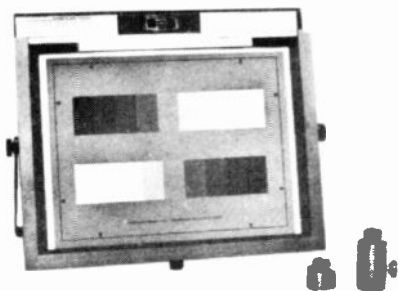

TEST CHART SYSTEM

ENG 2 CHART SYSTEM

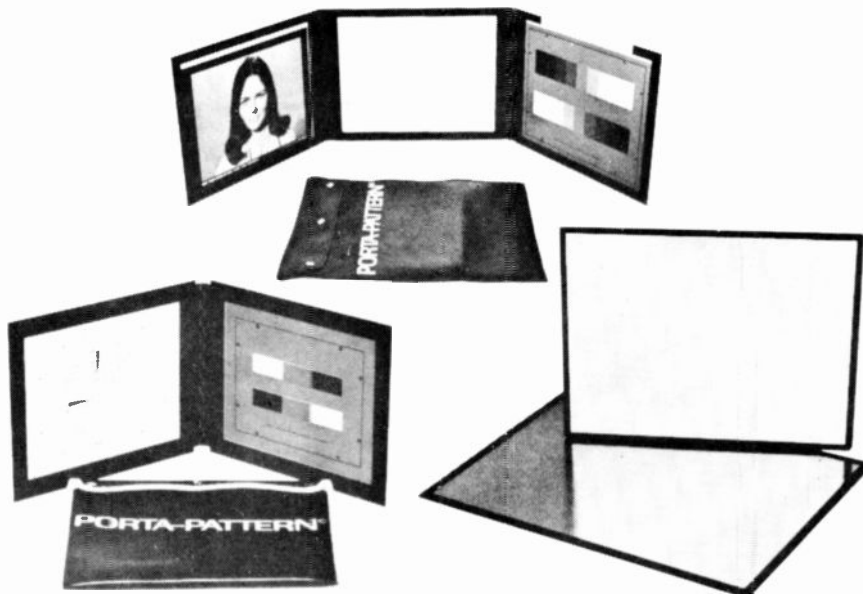

PORTA-FLECTOR ENG/EFP WHITE BALANCE/REFLECTOR

### TEST CHART SYSTEM

- End the test pattern problem in studio or field with completely portable 9" x 12" charts
- Designed for self-standing or mounting on standard microphone or light stand
- Spirit level is an integral part of unit design for horizontal alignment accuracy
- Lightweight aluminum extrusion chart holder with three feet and alignment controls
- Each chart framed and recessed on high-impact acrylic plastic to assure protection from abrasion and water damage
- Each set contains one each standard resolution, registration, linearity and logarithmic reflectance chart

#001-10	Four Chart System with NO adapters	\$295.00
#001-11	Four Chart System with microphone stand adapter	\$310.00
#001-12	Four Chart System with light stand adapter	\$320.00
#001-13	Four Chart System with mic and light stand adapters	\$335.00
#001-15	Microphone stand adapter	\$ 33.00
#001-16	Light stand adapter	\$ 36.00
#001-17	Aluminum frame assembly, complete W/O adapters	\$ 170.00
#001-50	Dual system carrying case	\$ 80.00
#001-51	Single Chart Carrying Case	\$ 55.00
#001-24*	Resolution Chart	\$ 70.00
#001-25*	Linearity (Ball) Chart	\$ 70.00
#001-26*	Registration Chart	\$ 70.00
#001-27*	Nine-Step Log Chip Chart	\$100.00
#001-28	Production Slate	\$ 60.00
#001-29	Blank plastic chart frame	\$ 50.00
#001-32	Multi-Burst Chart, 8 MHz	\$ 70.00
#001-33	Window Chart	\$ 70.00
#001-34	Chess Board Chart	\$ 70.00
#001-35	Reverse Registration Chart	\$ 70.00
#001-36	BBC #61P Flesh Tone Reference Chart	\$140.00
#001-37	Pulse Bar Camera Chart	\$160.00
#001-38	CCIR Linearity (Ball) Chart (Grass Valley)	\$ 70.00
#001-39	Auto-Registration Chart (Fernseh)	\$ 70.00
#001-40	Lens Focus Chart	\$ 70.00
#001-41	Depth of Modulation Chart (AmpereX)	\$ 70.00
#001-42	Line Resolution Chart (CEI)	\$ 70.00
#001-43	Full-Field Color Bar Chart	\$140.00
#001-44	Eleven-Step Log Chip Chart (Available After June 1982)	\$110.00

### ENG 2 CHART SYSTEM

The PORTA-PATTERN ENG/EFP Chart System has been designed to provide basic alignment, registration, color balance and auto-white balance information for fast Electronic News Gathering or Field Camera set-up.

The system consists of a Registration Chart and specially designed Color Balance Chart, mounted on durable white acrylic plastic. The two plastic frames are hinged together, and the charts are folded face-to-face when not in use. Black Velcro provides a light and dirt seal when the system is closed and the white plastic has a non-reflective surface for auto-white balance use.

The Registration Chart is the standard PORTA-PATTERN Registration Chart in the 6 3/4" x 8 4" format, with the recommended target scan information surrounding the chart. The Color Balance Chart, in the same format, contains logarithmic grey scale information to set black level, gain, gamma and black and white clip (60% white, 13.4% gamma crossover and 3% black on a standard 12% background).

The ENG-EFP Two Chart System is supplied with an expanded vinyl nylon coated storage case to protect the unit during transit and while on location.

#006-10	ENG Portable Two-Chart System, Registration and Color Balance, including Carrying Case	\$185.00
---------	--	----------

### ELECTRONIC FIELD PRODUCTION 3 CHART SYSTEM

In order to provide a greater range of available test patterns in a package better adapted to the portability of EFP camera systems, PORTA-PATTERN has developed a Three-Chart System which will accept ANY combination of three charts presently available in the PORTA-PATTERN catalogue. This system, when closed, takes up no more space than a single PORTA-PATTERN Test Chart.

The system consists of three plastic frames, similar to those used for all individual PORTA-PATTERN Charts, hinged end-to-end with a unique system which allows the plastic frames to be folded upon themselves, thus providing complete surface protection for all three charts.

The entire system is held closed by a Velcro closure system, and an expanded vinyl-coated nylon case is included to provide a complete, three chart system in a package less than 15" high, 18" wide and 1 1/2" thick.

Since there are currently over 150 combinations of PORTA-PATTERN charts which can make up the system to each customer's requirements, it is imperative that your Purchase Order include the enclosed layout sheet, showing which Test Chart you wish in each of the three positions.

#014-10	EFP Three Chart System with three Black and White Geometric Test Patterns, including case	\$205.00
#014-11	EFP Three Chart System with two Black and White Geometric and one Nine-Step Log Chip Chart, including case	\$230.00
#014-12	EFP Three Chart System with one Black and White Geometric, one Log Chip and one of either Color Bar, BBC #61P Flesh Tone or Pulse Bar chart, including case	\$260.00

NOTE: To add Production Slate to rear of center panel of any of the above EFP Three Chart Systems add \$45.00 to List Price shown.

### PORTA-FLECTOR™ FIELD LIGHT REFLECTOR/AUTO-WHITE STANDARD

The PORTA-FLECTOR™ has been designed primarily for use by ENG and EFP field crews to provide a lightweight, portable reflector for use on exterior interviews, "stand-uppers", etc. when a small amount of reflected light, especially from below, will provide a more even facial illumination on the on-camera personnel.

Further, the reverse side of this unit will provide camerapersons with a constant, known white matte-finish surface for use with those cameras utilizing an Auto-White Color Balance System.

The unit is manufactured of flexible 0.060 white vinyl, with the Auto-white side being of a dull, matte non-reflective finish.

The reflector side of the unit is covered with Roscoflex-H™ reflector material, manufactured by Rosco Laboratories, Inc. The reflectance characteristics of this material are strongly directional and retain much of the characteristics of the original light source.

The PORTA-FLECTOR™ is manufactured in two sizes for ease of usage in existing PORTA-PATTERN™ Systems. The larger size is manufactured in the same size as all our standard test charts, and will fit in either the aluminum holder of the standard four chart system, or in the case of the EFP Three Chart System.

The smaller unit is designed to be used in conjunction with the PORTA-PATTERN™ ENG Two Chart System. Additionally, this smaller unit has been designed to fit in the carrying case of most field-type video tape recorders, between the recorder and the case, thus eliminating the need for additional pieces of loose equipment.

#019-10	PORTA-FLECTOR™ field light reflector Auto-White Standard 12" x 15"	\$65.00
#019-11	PORTA-FLECTOR™ as above 9" x 12"	\$55.00



# VIDEO PROMPTER SYSTEMS

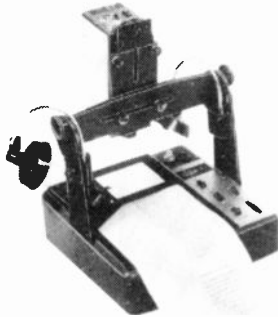

## VPS-100 CONSOLE TRANSPORT

We have simplified prompting! By eliminating elements such as the large-size typewriter, special paper, special ribbons, replacing broken keys, typewriter adjustments, and transposing copy, we figured what can't go wrong, won't go wrong.

These unique prompting systems offer the broadcast industry and its allied fields, a versatile, efficient and rapid method for providing prompter copy through a video signal.

Prompter copy is prepared on standard 8½" x 11" single sheets of paper using any manual or electric typewriter. The prompter script is conveniently fed through the aperture of the VPS-100 by means of 'taping' the individual sheets into a continuous roll; or by placing the individual sheets of copy on the conveyor belt of the VPS-300, thus eliminating the need for 'taping'.

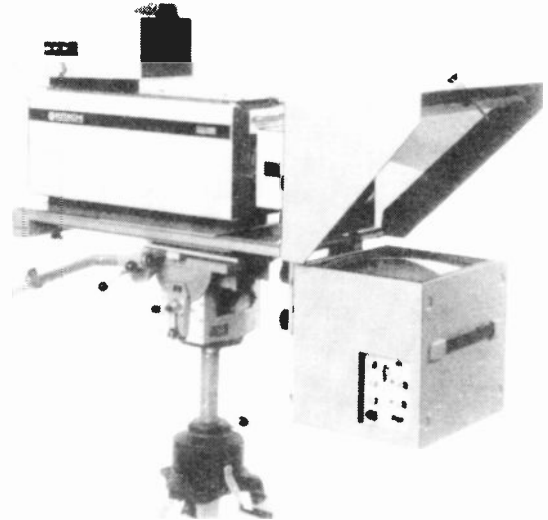

### ONE VPS-100 PROMPTER SYSTEM

- 1 VPS-100 Console Transport
- 1 Vidicon Camera w/lens
- 1 14" Prompter/Monitor
- 1 Remote Hand Control
- 1 50' Coaxial Cable
- 1 Prompter Camera Mount
- 1 Camera Balancing Assembly
- 1 VPS Eye-Line
- 1 Instruction Manual **\$4175.00**

### TWO VPS-100 PROMPTER SYSTEM

- 1 VPS-100 Console Transport
- 1 Vidicon Camera w/lens
- 2 14" Prompter/monitor
- 1 Remote Hand Control
- 2 50' Coaxial Cable
- 2 Prompter Camera Mount
- 2 Camera Balancing Assembly
- 2 VPS Eye-Line
- 1 Instruction Manual **\$5750.00**

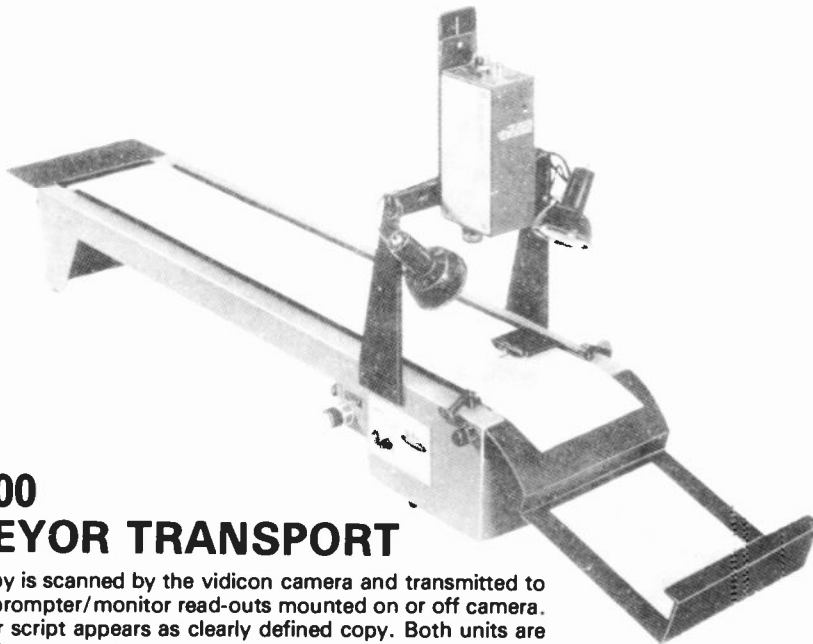

## VPS-300 CONVEYOR TRANSPORT

Prompter copy is scanned by the vidicon camera and transmitted to one or more prompter/monitor read-outs mounted on or off camera. The prompter script appears as clearly defined copy. Both units are equipped with a remote hand control for easy operator control.

When used with the VPS Eye-Line, prompter copy is superimposed directly over the taking lens of the television camera for direct "Eye-to-Eye" contact with the viewing audience. The high brilliance image is clearly visible to the speaker but in no way detectable by the camera lens.

The adaptability of the VPS systems over conventional prompting equipment enables you to derive maximum returns both technically and financially because of the reduction in preparation of prompter copy and general running costs.

### ONE VPS-300 PROMPTER SYSTEM

- 1 VPS-300 Conveyor Transport
- 1 Vidicon Camera w/lens
- 1 14" Prompter/Monitor
- 1 Remote Hand Control
- 1 50' Coaxial Cable
- 1 Prompter Camera Mount
- 1 Camera Balancing Assembly
- 1 VPS Eye-Line
- 1 Instruction Manual **\$4975.00**

### TWO VPS-300 PROMPTER SYSTEM

- 1 VPS-300 Conveyor Transport
- 1 Vidicon Camera w/lens
- 2 14" Prompter/Monitor
- 1 Remote Hand Control
- 2 50' Coaxial Cable
- 2 Prompter Camera Mount
- 2 Camera Balancing Assembly
- 2 VPS Eye-Line
- 1 Instruction Manual **\$6375.00**

Prices and Specifications Subject to Change Without Notice.

# QUANTA™



O-6/B Color



Font 2: Bold Sans Serif



Q-6/A Monochrome

## TELEPRODUCTION GRAPHICS TITLER

### Q-6

- 24 Character Sizes — Selectable by Row
- Upper and Lower Case Font of Capital Letters Selectable by Character
- Character Resolution, up to 32 Horizontal Pixels
- Random Access to 192 Resident, Positionable Titles
- 6,000 Character Memory — Selectable Page Sizes
- Choice of 3 Character Fonts
- Absolute Centering by Row or Page
- Incremental Horizontal Character Positioning by Row
- Roll to Fixed Display or Full Screen
- Crawl and Title in any Raster Position
- 2 Speed Roll, Crawl and Flash
- Insert/Delete and Open/Close Editing

- Save or Exchange Rows or Pages
- Line and Block Graphics
- 6 Background Colors Plus Gray and Black Selectable by Row\*
- Color Graphic Separators\*
- Sync-Lock and Color Phase-Lock or Stand Alone\*
- Memory Protect Nicad Batteries and Charger
- Built-In Maintenance "De-Bug" Analyzer

\*Not Applicable in Monochrome Q-6/A

Q-6/A, English Keyboard .....	\$6,995.00
Q-6/A, International Keyboard .....	8,495.00
Q-6/B, English Keyboard .....	8,495.00
Q-6/B, International Keyboard .....	9,995.00

Prices and Specifications Subject to Change Without Notice.

# QUANTA™

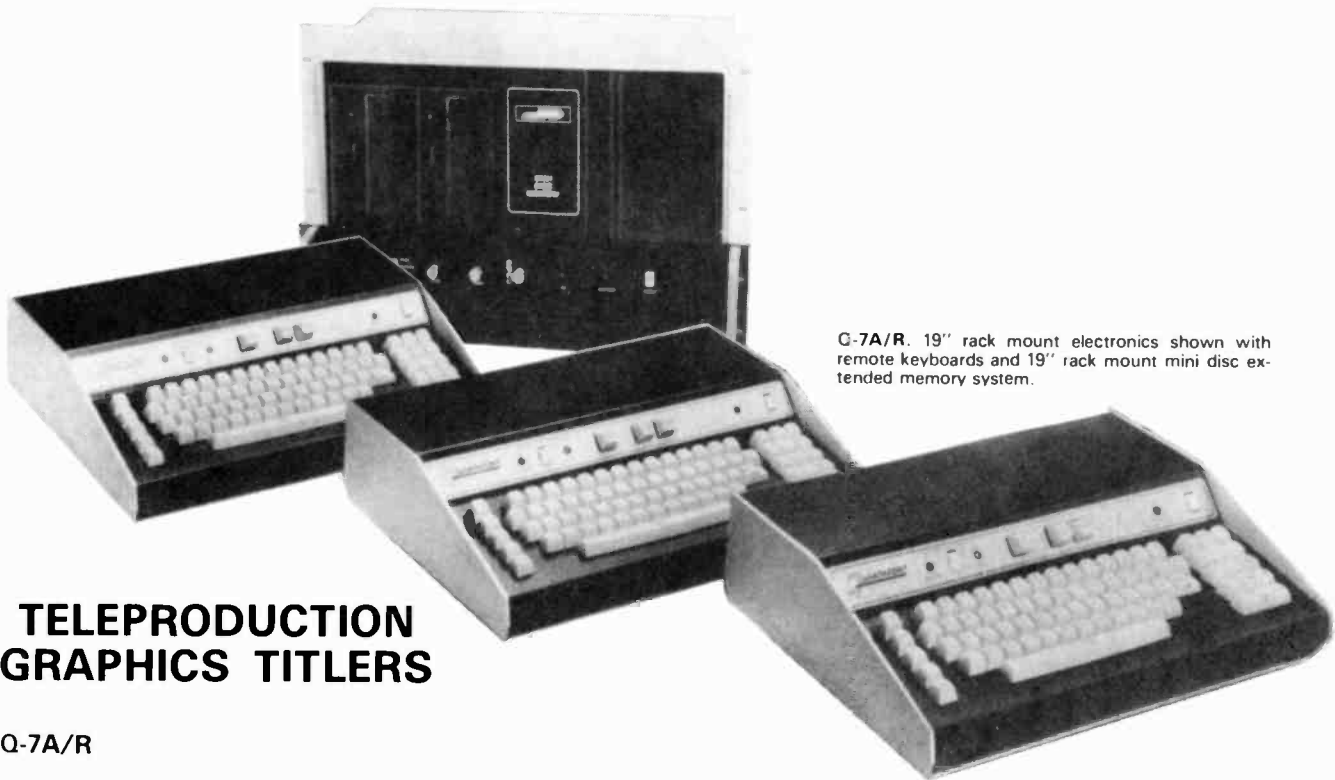

Q-7A/R. 19" rack mount electronics shown with remote keyboards and 19" rack mount mini disc extended memory system.

## TELEPRODUCTION GRAPHICS TITLERS

### Q-7A/R

The Q-7A/R rack mount configuration was developed for applications requiring multiple remote keyboards. All display capabilities of the Model Q-7A are provided with the addition of an RS-232-C input at 9600 Baud. Remote keyboards contain independent power supplies and interconnect via coaxial cable at distances up to 500 feet between keyboards. There are no practical limitations to the number of keyboards in the system. Keyboard delegation is accomplished by switch function at each keyboard with "on line" and "busy" LED indicators on each keyboard bezel. Priority is assigned to the keyboard that is first in the series. There is also a "request" capability from any keyboard that indicates busy.

**EXTENDED MEMORY SYSTEMS:** Rack mount single and dual mini disc storage systems with 6-inch monochrome edit monitors (NTSC only) for storage compartment are available for Q-7A/R.

**DIMENSIONS:** Q-7A/R electronics: 19"W x 5 1/2"H x 19 1/2"D; Single or dual disc: 19"W x 8 3/4"H x 19 1/2"D; Remote keyboard: 17"W x 5"H x 12"D.

Q-7A/R Rack mount electronics with Software for English ..... \$16,495.00

Q-7A/R Rack mount electronics with software for International ..... 18,495.00

### QVII

#### CHARACTER DISPLAY

- 20 nsec character resolution with NANO-LOG™
- Multiple upper and lower case resident fonts selectable by character • 20 character size selections of all fonts by row • Font raster line heights from 8 to 64
- Common height font intermix by character

#### RESIDENT MEMORY

- 192-row memory — 6,144 total character capacity
- 12, 16-row pages — operator selectable page sizing
- Memory protect battery and charging circuit

#### COMPOSITION AND OPERATION

- High resolution, color, edit/status output • Erase from cursor to end of row, page or memory • Automatic, absolute centering by row, page or memory
- Horizontal text positioning by row • Insert/delete and open/close editing • Text relocation by row or

- page • Automatic font change by row, page or memory • Full raster vertical title positioning • Random or sequential page access • 32 tab positions • Self-diagnostic maintenance program

#### COLOR AND EFFECTS

- Colorized characters by row • Colorized background by row • Full borderline or shadow edging by row • Color graphic separators • 8 color selections including black and white or gray • Character and/or background color matte over video

#### DYNAMIC AND SPECIAL DISPLAY

- Roll any length message up to 192-row resident memory • Roll to fixed display or full screen • Crawl any raster position, any font and with fixed text • 2 speed control roll, crawl and flash • Roll and crawl simultaneously • Auto page fade — 0 to 2 seconds
- Real time clock positionable in any display row • Line and box graphics • International alphabets optional — all fonts • Custom logo capability

QVII. English keyboard ..... \$11,995.00  
QVII. International keyboard ..... 13,995.00



Q-VII

# QUANTA™

Q-7A with Mini-Disc Memory

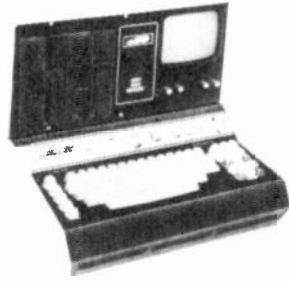

Q-7A

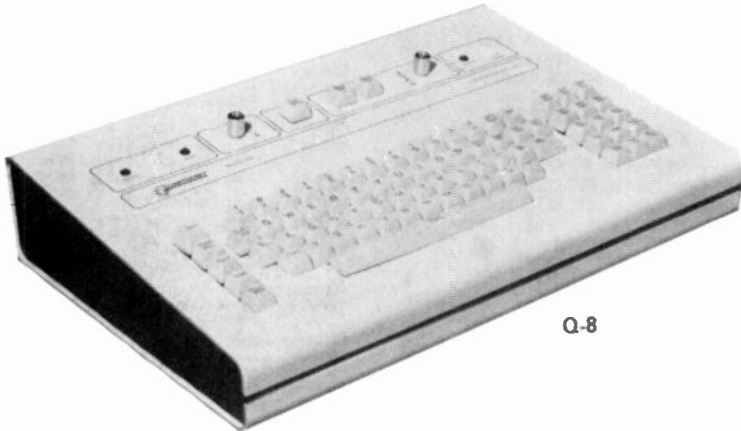

Q-8



Microgen

## FONT LOADABLE TITLING SYSTEM

### Q-8

Microcomputer based, high resolution, broadcast quality titling from an extensive library of type faces and fonts disc load and dual disc read/write memory... multiple type faces and fonts in one resident load... logos... color background and characters... borderline... shadow... and more.

#### Standard Features

- Up to 18 fonts loadable in resident memory • 3 different type faces per resident load • Multiple font sizes per type face per load • Disc library of type faces and font sizes • Expandable library selection • Custom font design capability • Custom design logo capability • Proportional characters and spacing • 26.1 nsec base character resolutions • 16 to 96 raster line height character display • Regular, condensed and extended type faces • Random and sequential access to both 100 page discs • Unlimited "next disc" sequencing • Full disc redundancy and copy capability • Colorized characters by row • Colorized backgrounds by row • Full borderline and shadow edging by row • Color graphic separators • Colorized graphic blocks and underline • 8 color selections including black and white or gray • Character and/or background color matte over video • Roll ar... length message • Crawl any raster position and with fixed text • 4-speed roll, crawl and flash • High resolution color edit / status output • Erase from cursor to end of row or page • Automatic absolute centering by row or page • Automatic right margin justification by row • Horizontal text positioning by row • Interword spacing control • Selectable intercharacter spacing control • Interword spacing control • Insert/delete and open / close editing • Page or row save buffer • Full raster vertical title positioning • 32 unique tab positions • Keyboard delegation for multiple remote keyboards

Q8 1 channel/dual 8" floppy disc... 27,995.00  
2 channel/dual 8" floppy disc... 39,995.00  
Add'l keyboard... 3995.00

## TELEPRODUCTION GRAPHIC TITLER

### Q-7A

A new dimension in broadcast graphic titling... true proportional typography integrated with microcomputer efficiency in a self-contained low cost system.

- 16 resident fonts • proportionally structured and spaced characters • 20 nsec ave. effective start point resolution

#### VIDEO TYPOGRAPHY

- True proportional characters and spacing
- 20 nsec character resolution with NANO-LOG™
- 16 resident fonts — Upper and lower case "Universal"; "Bolt Bold" large and small caps by row
- Font raster line heights from 8 to 64
- Common height font intermix by character

#### Extended Memories

Flexible Disc Memory Accessory: Single or dual mini-disc storage systems provide random or sequential (next/prior) access to 100 pages per disc with page access time of less than .5 second. Each page contains total data storage (text, attributes and program control) for 100, 16-row pages. In addition, each disc stores a data Block of the entire 5,120 character memory for credit rolls, team titles, etc. Total storage per disc is 56,320 characters.

#### Q7B Same Features As Q7A Only:

- Your Choice of any 2 fonts
- Word by word color will colorize from space to space

Q7A Q7A-EM ..... 14,495.00  
Q7A-EM/MDM-2 with disc memory .... 17,995.00  
Q7B Q7B-EM ..... 15,495.00  
Q7B EM/MDM-2 with disc memory ..... 18,995.00

Q7A to A Q7B Update ..... 1495.00

## MICROGEN

### STANDARD

16, 12-row pages of internal resident memory. Over 6,000 characters • 32 x 16 pixel character matrix • 2 horizontal character sizes selectable on a row by row basis. 24 or 32 characters per row • Title mode of 64, 3-row titles; positionable at any raster location • Automatic page sequencing in durations from 0 to 99 seconds • Roll mode allows continuous or one-time roll of entire 192-row memory. 10 selectable roll speeds • Crawl mode up to 6,000 characters. Positionable at any raster location and with static information. Continuous or one time crawl in any one of 10 selectable speeds • Flash on a character by character basis • Absolute centering by row or page • Right-hand justify by row • Left-hand justify by row or page • Random or sequential page access • Full borderline edging—selectable on or off • One-row status display • Program on/off for keyboard preview • RAM memory protect battery and charging circuit • CMOS RAM for extended battery back-up life • Automatic RAM memory check at power on • Open/Close editing on a row by row basis • Insert/Delete editing • Selectable interrow spacing control • Graphic separators • Ease of operation • And more...

### OPTIONS

- Color/Sync option. 10 selectable character colors by row in downstream application. 10 selectable background colors by row in upstream application • Complete second channel option allows composition while on air.

Microgen Single channel MG100S ..... \$2995.00  
Dual channel MG100D ..... 4345.00  
Color Sync option per channel ..... 550.00  
Second channel option ..... 1350.00



Our Most Popular

### HUSKY TRIPOD\*

Load Capacity . . . . . Up 59 17 lbs. (7.7 kg)  
 Height Extended . . . . . 57"-72" (144.8-182.9 cm)  
 Height Telescoped . . . . . 23"-31" (58.4-78.7 cm)  
 (Dependent on model)  
 Column Rise . . . . . 16" (40.6 cm)  
 Tilt . . . . . 60° up, 90° down  
 Pan Rotation . . . . . 360°  
 Weight . . . . . 7 lbs. (3.2 kg)

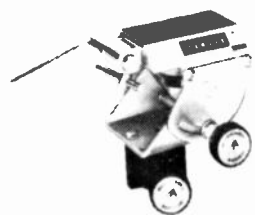

### SAMSON FRICTION HEAD\*

Load Capacity . . . . . 25-35 lbs. (11.4-15.9 kg.)  
 Tilt Angle . . . . . 45° up, 90° down  
 Pan Rotation . . . . . 360°  
 Dimensions . . . . . 5 1/2" x 6 1/2" x 6 1/2"  
 (14.1 x 16.6 x 16.6 cm)  
 Weight . . . . . 2 1/2 lbs. (1 kg)



### HERCULES HYDRO FLUID HEAD\*

Load Capacity . . . . . 50 lbs. (22.7 kg)  
 Tilt Angle . . . . . 80°  
 Pan Rotation . . . . . 360°  
 Dimensions . . . . . 6" x 5" x 6"  
 (15.2 x 12.7 x 15.2 cm)  
 Weight . . . . . 8.5 lbs. (3.9 kg)



### SAMSON MOBILE PEDESTAL #4-74500-6

Load Capacity . . . . . 40 lbs. (18.2 kg)  
 Maximum Height . . . . . 55" (139.7 cm)  
 Minimum Height . . . . . 37" (94 cm)  
 Weight . . . . . 23 lbs. (10.5 kg)  
 Wheel Circle . . . . . 28" (71.1 cm)



### SAMSON MINI FLUID HEAD\*

Load Capacity . . . . . 20 lbs. (9.1 kg)  
 Tilt Angle . . . . . 90°  
 Pan Rotation . . . . . 360°  
 Dimensions . . . . . 4" x 5" x 6"  
 (10.2 x 12.7 x 15.2 cm)  
 Weight . . . . . 4.5 lbs. (2.0 kg)



### SAMSON CAM HEAD #4-72300-3

Load Capacity . . . . . 40 lbs. (18.1 kg)  
 Tilt Angle . . . . . 30° up, 40° down  
 Pan Rotation . . . . . 360°  
 Dimensions . . . . . 8 1/2" x 6 1/2" x 4 1/2"  
 (21.6 x 16.6 x 11.5 cm)  
 Weight . . . . . 5 lbs. (2.3 kg)  
 Mountings . . . . . 1/4" x 20 Camera Screw, Adjustable Fore and Aft 3 1/2" (8.9 cm) Mounting surface 3 1/2" x 6" (8.9 x 15.2 cm)



### SAMSON TRIPOD #4-73010-7

Load Capacity . . . . . 40 lbs. (18.2 kg)  
 Maximum Height . . . . . 76" (193 cm)  
 Minimum Height . . . . . 34" (86.4 cm)  
 Column Rise . . . . . 18" (45.7 cm)  
 Weight . . . . . 10 lbs. (4.5 kg)

A 3/4 size version is available under #4-73500-7  
 Maximum Height . . . . . 55" (139.7 cm)  
 Minimum Height . . . . . 21" (53.3 cm)



### SAMSON JUNIOR FLUID HEAD\*

Load Capacity . . . . . 30 lbs. (13.6 kg)  
 Tilt Angle . . . . . 85°  
 Pan Rotation . . . . . 360°  
 Dimensions . . . . . 4" x 6" x 6"  
 (10.2 x 15.2 x 15.2 cm)  
 Weight . . . . . 7.0 lbs. (3.2 kg)



Our Most Popular

### HUSKY DOLLY

Load Capacity . . . . . 50 lbs. (22.7 kg)  
 Wheel Size . . . . . 4" x 3/4" w/brake  
 (10.2 x 1.9 cm)  
 Circle Diameter . . . . . 35" (88.9 cm)  
 Folds to . . . . . 4" x 6" x 19"  
 (10.2 x 15.2 x 48.3 cm)  
 Weight . . . . . 8 lbs. (3.6 kg)



### SAMSON DOLLY

Load Capacity . . . . . 50 lbs. (22.7 kg)  
 Wheel Size . . . . . 4" x 3/4" (cm: 10.2 x 1.9)  
 Wheel Circle . . . . . 42" (106.7 cm)  
 Folds to . . . . . 6 1/2" x 7 1/2" x 21 1/2"  
 (16.5 x 19.0 x 54.6 cm)  
 Weight . . . . . 9 lbs. (4.1 kg)

#### Accessories

4 75010-5	Side Arm - 12" Offset w/ stud to accept Friction, Cam and Fluid Heads	50.00
4-75110-3	Spike Tips (Set of 3)	45.00
4-75350-5	Hi-Hat	80.00

\*\*Set for Dual Handle Operation

### HUSKY

#### T.V. Husky\*

5-95534-9	Husky Tripod w/ Counterbalance Head, 2 Section Legs	1170.00
5-95542-2	Husky Tripod w/ Counterbalance Head, 3 Section Legs	180.00
5-95549-7	Husky Tripod w/ Counterbalance Head, 4 Section Legs	195.00
5-95565-3	Husky Tripod w/ Counterbalance Head, Struts, 2 Section Legs	190.00
5-95810-3	Husky Trolley w/ Counterbalance Head, Struts, 3" Detachable Wheels	230.00

#### Dolly

5-95054-8	Husky Dolly, 4" Wheels w/ Center Locking Device	90.00
-----------	---	-------

#### Heads Only

5-95054-7	Husky Safety TV Head for Tripod	95.00
5-95050-0	Husky 3D Head for Tripod	105.00

#### Husky Tripod Only

5-95000-1	Husky Tripod w/o Column, w/o Head, 2 Section Legs	110.00
5-95031-6	Husky Tripod with Column, No Head, 3 Section Legs	135.00

#### Accessories

5-95055-0	Carrying Case for Husky Tripods	35.00
-----------	---------------------------------	-------

#### Photographic Tripods

5-95580-2	Husky "Elevator" 3 Section Legs	200.00
5-95540-6	Husky "Stubby" 4 Section Legs	210.00
5-95581-0	Husky "Hi Boy" 4 Section Legs	230.00
5-95560-4	Husky "Lift" 3 Section Legs	190.00

### SAMSON

#### Tripods, Pedestals, Trolleys

4-70150-4	ENG/EFP Tripod	280.00
4-73010-7	Tripod with Elevator	300.00
4-73500-7	3/4 Size Tripod with Elevator	295.00
4-73520-5	3/4 Size Tripod with Elevator and Spike Tips	320.00
4-74500-6	Mobile Pedestal	450.00
4-74810-9	Trolley	330.00
4-75810-8	Stationary Column Unit (includes side arm and pan head)	200.00
4-78100-1	Stationary Pedestal	330.00
4-79000-2	Elevator Column Unit (for bench or cart mount)	190.00

#### Heads

4-72011-6**	Friction Head with Standard Counterbalance Spring	150.00
4-72013-2**	Friction Head with Heavy Duty Counterbalance Spring	160.00
4-72300-3**	Cam Head	375.00
4-72411-8	Still Head	125.00
4-72512-3	Geared Still Head	220.00
4-72612-1	Geared Movie Head	260.00
4-7280X-X**	Mini Fluid Head, Wt. Cap. 20 Lbs.	336.00
	4-72800-2 with Pro Jr. Base	
	4-72801-0 with Ball Base	
	4-72802-8 with Samson Column Base	
	4-72803-6 for use with 4-70150-4 ENG/EFP Tripod	
4-7285X-X**	Junior Fluid Head, Wt. Cap. 30 Lbs.	586.00
	4-72850-7 with Pro Jr. Base	
	4-72851-5 with Ball Base	
	4-72852-3 with Samson Column Base	
	4-72853-1 for use with 4-70150-4 ENG/EFP Tripod	
4-72910-9	Semi-Permanent Friction Head	105.00
4-75081-6	Second Control Handle for Friction, Cam and Fluid Heads	44.00

#### Dollies, Cable Guards

4-78010-4	Dolly - for use with 4-70150-4 and 4-73010-7 Tripods	120.00
4-78110-2	Cable Guards - Set of 3	35.00

#### Adapters

4-75450-3	Samson Elevator Column to Pro Jr. Type Panhead	80.00
4-75750-6	Samson Column to Hercules Panhead	38.00
4-75780-5	Hercules Column to Samson Panhead	42.00
4-75810-6	Transit Adapter (ASA 3 1/2 x 8)	105.00



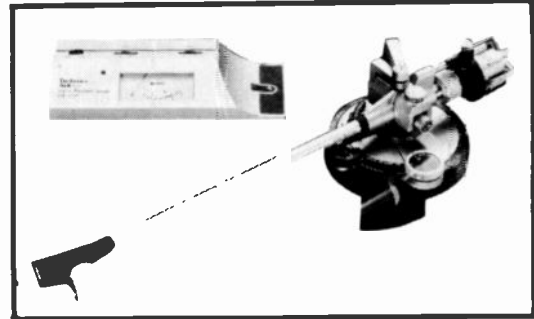

### SL-1015 Quartz Synthesizer Direct Drive Turntable System

The Technics SL-1015 is a high-performance turntable system consisting of the SP-15 Quartz Synthesizer Direct Drive Turntable, the SH-15B1 anti-resonant Turntable Base, and the EPA-500 System Tonearm with arm base and electronic stylus pressure gauge. The System Tonearm has special significance to the audiophile because of its interchangeable arm assembly. Optional arm units of various masses can be purchased and used to accommodate virtually any cartridge compliance.

Discriminating audiophiles will be pleased with this turntable system that brings together a turntable with selectable, quartz pitch control adjustable in three speeds in 0.1% steps to  $\pm 9.9\%$  (for a total of 597 possible steps), a single molded, heavy-rubber material base, and a tapered, tubular System Tonearm. The sum of these components adds up to a very remarkable turntable system — even more remarkable than an examination of its individual parts might suggest.

#### Features

- Full cycle detection frequency-generator and integral rotor-platter direct-drive motor.
- Very efficient pulsed power supply circuit.
- Good connection between arm unit and arm base thanks to a slide-in, self-cleaning connector with gold-plated terminals.
- Low capacitance (41.5 picofarads per meter) and low resistance (39.5 milli-ohms per meter) phono cable.
- Pitch lock device for locking speed selector and pitch controls.

### SL-1200MK2 Quartz Synthesizer Direct Drive Turntable System

The SL-1200MK2 represents the next generation of the popular SL-1200, incorporating numerous improvements over the original. In addition to begin quartz-locked direct drive, it permits continuous speed adjustment under quartz control (within a range of  $\pm 8\%$ ). Its starting torque is a high 1.5 kg·cm (1.3 lbs·in), with the platter reaching rated speed within 0.7 second from standstill. It also maintains a tighter lock on the selected speed than did the original SL-1200. The SL-1200MK2 should also be virtually feedback-proof because of its special base design. The platter itself is damped on both sides to avoid ringing.

#### Features

- Quick stops are achieved with a fully electronic braking system.
- A strobe illuminator is provided. The stroboscope is controlled by the extremely stable quartz oscillator, rather than potentially unstable AC line frequency.

- Power on/off control built-into strobe illuminator for ease-of-operation.
- Soft-touch start/stop switch allowing precision control capability without the annoyance of accidental operation.
- Technics integral rotor/platter motor construction with full cycle detection FG.

### EPA-500 System Tonearm

The EPA-500 tonearm system is probably the most thorough solution to the problem in existence today. The tonearm is actually five different ones with optimized damped counterweight assemblies for each. The basic arm assembly's effective mass is 8 grams, which is suitable for most cartridges now on the market. Should you wish to use a very high-compliance cartridge, you can purchase the optional "E" arm unit, whose lower effective mass will keep the system resonance around 10 Hz. Or should you want to use a cartridge with lower-than-average compliance, you can select the appropriate "M", "L" or "G" arm units. In each case, the right arm system will place the resonant frequency at or very near 10Hz, while the built-in counterweight damping system will attenuate any resonances that occur at that point. Furthermore, the arm units are quickly and easily interchanged.

And every arm unit is made from titanium nitride, a material that combines lightness with very high strength. This material is also very non-resonant, so it is unlikely to transmit airborne or mechanical vibrations to the stylus, a fact which contributes to the extreme clarity and sonic neutrality that can be achieved with this arm.

Supplied with this tonearm system is a unique and valuable accessory, the Technics Stylus Pressure Gauge. Operating on the semiconductor strain gauge principle, this purely electronic device employs two semiconductor strain gauge elements and two transistors to give highly accurate readings on a large meter. The gauge is sensitive to very slight variations in tracking force so that you can obtain the optimum adjustment for each of your cartridges.

#### Features

- Precise tonearm height adjustment up to 20mm is possible with 12-spiral helicoid.
- Large, rugged base of diecast zinc.
- Advanced, damped cueing system for smooth raising and lowering of the tonearm.
- Precise anti-skating device acts in lateral axis of tonearm movement.
- Sturdy, integrated headshell designed for minimum resonance and low weight.

A Major Breakthrough in Speaker System Technology that Clearly Improves Musical Reproduction.

The most obvious difference between the Technics honeycomb disc speaker system and conventional speaker systems is that the speaker units are flat instead of conical. This flat sound-radiating surface at last puts an end to much of the distortions inherent in the traditional cone-shaped design.

The honeycomb disc greatly simplifies linear phase speaker system construction because of two reasons.

First, the honeycomb disc speaker offers a wide, flat and smooth frequency response so that the crossover network can be simplified. And secondly, the acoustic center of a honeycomb disc speaker is clearly defined (it extends across the whole surface of the driver) instead of centering vaguely around the voice coil, as is the case with cone-shaped drivers. This means that there is no need for staggering the speaker units from top to bottom of the front baffle.

As a safety precaution all of the honeycomb disc speaker systems are equipped with separate thermal relays that operate to shut off input signals to individual drivers when coil area temperature rises above a certain safe limit. The thermal relays are easily resettable. An LED load indicator lights up to indicate the input limit is being approached. When more than one of the thermal relays are activated, their indicator will be more brightly lit.

### SB-3 2-Way System

#### Specifications:

- Configuration: 2-way, 2-speaker
- Speaker units: Woofer: 9" (22cm); Honeycomb Disc Tweeter: 1-1/8" (2.8 cm) Honeycomb Disc
- Impedance: 8 ohms
- Input power: 75W, music; 50W, DIN
- Output level: 87 dB/W (1.0m)
- Frequency range: 45 Hz—35 kHz (-10 dB)
- Crossover frequency: 2000 Hz
- Dimensions: 10-5/8"W x 17-3/8"H x 9-3/8"D (27 x 44 x 23.7cm)
- Weight: 19 lbs. (8.6 kg)

\$450.00/pair

### SB-5 3-Way System

#### Specifications:

- Configuration: 3-way, 3-speaker
- Speaker units: Woofer: 9" (22cm) Honeycomb Disc Midrange: 3-1/8" (8 cm); Honeycomb Disc Tweeter: 1-1/8" (2.8cm) Honeycomb Disc
- Impedance: 8 ohms
- Input power: 110W, music; 75W, DIN
- Output level: 87 dB/W (1.0m)
- Frequency range: 38 Hz—35 kHz (-10 dB)
- Crossover frequencies: 800 Hz, 4500 Hz
- Dimensions: 12-3/8"W x 22-7/8"H x 12-1/2"D (31.5 x 58 x 31.8 cm)
- Weight: 31 lbs. (14 kg)

\$325.00 each

### SB-7 3-Way System

#### Specifications:

- Configuration: 3-way, 3-speaker
- Speaker units: Woofer: 10" (25cm) Honeycomb Disc; Midrange: 3-1/8" (8cm) Honeycomb Disc; Tweeter: Leaf tweeter
- Impedance: 8 ohms
- Input Power: 130W, music; 90W, DIN
- Output level: 87 dB/W (1.0m)
- Frequency range: 34 Hz—125 kHz (at 10 dB below average level)
- Crossover frequencies: 900 Hz, 4500 Hz
- Dimensions: 14-1/8"W x 24-3/4"H x 12-1/2"D (36 x 63 x 31.8 cm)
- Weight: 42 lbs. (19kg) (including grille)

\$400.00 each



SB-3



SB-5

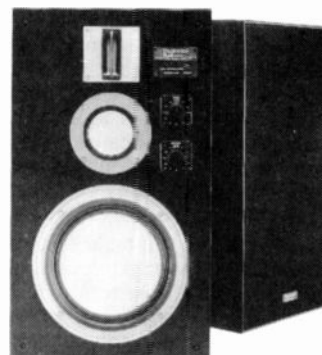

SB-7



SB-10

### SB-10 3-Way System

#### Specifications

- Configuration: 3-way, 3-speaker
- Speaker units: Woofer: 12-4/5" (32cm) Honeycomb Disc; Midrange: 3-1/8" (8cm) Honeycomb Disc Tweeter: Leaf tweeter
- Impedance: 8 ohms
- Input power: 150W, music; 100W, DIN
- Output level: 87 dB/W(1.0m)
- Frequency range: 28 Hz—125 kHz (at 10 dB below average level)
- Crossover frequencies: 400 Hz, 4000 Hz
- Dimensions: 15-7/8"W x 28"H x 12-1/2"D (40.2 x 71.1 x 31.8cm)
- Weight: 70.5 lbs. (32 kg) (including grille)

\$700.00 each



WR-130

## AUDIO MIXER

### RAMSA WR-130 8 IN/2-OUT AUDIO MIXER

The WR-130 is a portable, versatile mixer which is suitable for remote broadcasts, recording, or sound reinforcement. Its design offers high fidelity performance characteristics, extended frequency response, wide dynamic range, and noise free performance. The WR-130's high reliability and durable construction are designed to withstand abusive handling on the road.

#### Quality Engineering Features

Portable and ruggedly constructed. Can be connected to CUE or echo effect unit through PREMIX OUTPUTS. Can be connected to an echo effect unit through FROM ECHO and TO ECHO.

#### Input

Inputs 1 to 8 with XLR type connectors, offer a balanced input system which is created by RAMSA's sophisticated operational amplifier circuit. This reduces input noise to a maximum of -128 dB. The input level for inputs 1-4 can be selected at -70, -60, -50, -40 and -20 cBs while the input sensitivity of inputs 5-8 can be selected at -70, -60, -50, -40, -30 and -20 dBs. Inputs 1-4 are equipped in parallel with -52 dBs phono inputs connectors so that two stereo turntables can be connected. Inputs 1-8 are equipped with panpots for control of each input for both A and B program outputs. Inputs 7 and 8 have two pairs of connectors in parallel so that either XLR type connectors or phone plugs can be employed. Inputs 1-8 are equipped with equalizers which allow +/-12 dB variation in the levels at 100 Hz and 10 kHz. Inputs 1-8 are provided with peak level indicators which indicate input levels that exceed -3 dB before a clipping level.

#### Output

The rated output is +4 dBm, and the maximum output is +20 dBm. A and B program outputs accept either XLR connectors (balanced) or phone plugs (unbalanced). The outputs of master faders A and B contain equalizers which control +/-12 dB at both 100 Hz and 10 kHz. Two -20 dBs AUX IN terminals with an input impedance of 10 k ohms are provided for the connection of a sub-mixer or tape deck. Pin Jacks for A and B REC OUT are provided. Headphone output is switchable between PRE MIX and PGM for flexible monitoring. **\$995.00**



WR-8816

## MIXING CONSOLE

### RAMSA WR-8816 RECORDING MIXING CONSOLE

Ramsa has developed the WR-8816, a mixer specifically designed for recording applications. With it, the recording engineer has all the flexibility he requires at his disposal. The WR-8816 is designed to perform all its functions quickly and effectively, with a minimum of time wasted re-patching cords and changing set-ups.

The Input modules accommodate 16 LINE IN inputs. There are also 16 direct line outputs. The input signals may be mixed using the tape monitor controls in the Group modules with no changes in the wiring arrangements. The Send controls in the Group modules enable signals to be routed directly from the LINE IN inputs to the L and R cue Send busses in the Master module. Using the monitor section, the mic inputs may be employed without altering the patch connections, so recordings can be made while monitoring the actual input signals. With a total of 10 mixing buss lines (4 Group, 2 Master, 2 Send, and 2 Echo), all necessary outputs are provided. For additional flexibility, Ramsa has provided 16 insertion jacks on the Input modules. The user can exercise extremely precise control over each Input module; separately adjustable 3-band equalizer controls, echo controls, left and right send controls, and input faders are all included in each module.

Complete access to all 16 inputs via direct monitoring lines permits simultaneous monitoring without altering patch cord connections. The WR-8816 also allows monitoring of up to 16 channels. With the Solro switch, the post-fader signal may be monitored individually. The Send facility provides a pre-fader, pre-EQ signal for musician headphone monitoring. Playback monitoring is available.

Three individual equalizer controls are provided for each Input, with High, Mid, and Low frequency adjustments.

The WR-8816 includes refinements such as extensive use of ICs and transistors to reduce or eliminate many servicing problems. The modular design makes it easy to pinpoint most malfunctions.

The use of balanced input circuitry contributes to the low noise and frequency response exhibited by the WR-8816: Mic: 20 - 20,000 Hz +/-1 dB (60 dB Input level, 64 dB gain); Line: 20 - 20,000 Hz +/-0.5 dB (-20 dB Input level, 24 dB Gain); Mic Input Noise: -128 dB (IHF "A" WTD, 150 ohm source); THD: Less than 0.05% (20-20,000 Hz +20 dBm Output Level, 64 dB Gain), Maximum Output Level: +22 dB, CMRR: Above 70 dB (1 kHz minimum), Above 80 dB (typical). **\$5500.00**



## AUDIO MIXING CONSOLES



WR-8210

WR-8112

### RAMSA RECORDING CONSOLE WR-8210

#### 10 Inputs 4 Group Outputs For 4 and 8 Track Recording

- 10 inputs and 4 channel outputs
- Input levels: Mic: -70 — -30 dB with 40 dB trim, Line: -20 — 0 dB with 20 dB trim
- 3 knob equalizer: High: 4k/12kHz +/-12 dB shelving, Mid: 500/1.5kHz +/-12 dB peaking, Low: 60/180 Hz +/-12 dB shelving
- EQ bypass switch
- Input channel mute switch
- Insertion patch point at each input
- Sub in with level control and pan on each input
- Two Sub mix sends pre or post
- Solo switch at each input
- Direct output at each input
- Peak indicator at each input
- Buss assignment switch with pan pot
- Smooth straight line fader
- Stereo effect input with level control and buss assignment switch
- 2 sub mix outputs
- 14 point 3 colored LED bar graph
- Meters for Group output
- Group master trim at each group
- Straight group fader
- Insertion patch point at each group
- Stereo monitor with buss assignment switch, level and balance control
- 1W + 1W (8 ohms) stereo headphone jack on panel
- XLR type connector for mic input
- RCA pin jack for other input and output

**\$1800.00**

### RAMSA WR-8112 12 x 4 x 2 x 1 AUDIO MIXING CONSOLE

The RAMSA WR-8112 is a compact, 12 x 4 x 2 x 1 high performance, professional mixing console designed both for sound reinforcement and multi-track recording applications. It has access jacks on each input as well as the group outputs, L & R master outputs and mono master output.

Designed in a compact format, it meets the requirements of a wide variety of sound reinforcement and recording applications.

The WR-8112 is a human-engineered product, incorporating the latest circuit technology. Included in this concept is a modular approach to internal circuit boards, a built-in tape monitor function, and low noise electronically balanced Mic inputs.

The WR-8112 offers features such as Direct Outs, Access Point on each input, and Group and Master Outputs. It also includes L & R Monitor/Effect Outs, Send Out and Cue Send Out on the send section to connect both the echo unit and the musician's headphone amplifier. And on the 4 Group Outputs, either -10 dB or +4 dBm output is provided for compatibility with a wide variety of tape recorders.

On the master section, L & R outputs are provided with both +4 dB output level with 1/4 phone jacks and -10 dB output level with RCA pin jacks. Included on each input are: a peak-overload LED, a 3-band variable frequency EQ section, input selector with trim control, monitor/effect send control, send control with pre and post selector switch, groups/master L & R assign switches, pan-pot, channel on-off switch, solo switch and 60 mm travel straight line fader.

On the Output section, the WR-8112 provides stereo effects returns, group outputs, master L & R outputs, mono master output, and the effect/monitor and cue send controls. 48V phantom power supply are also provided at each input. On the 12-point LED bargraph meter section, selectors for group outs 1 - 4, L & R master outs, send, mono master out and solo out are provided.

**PRICE ON REQUEST**

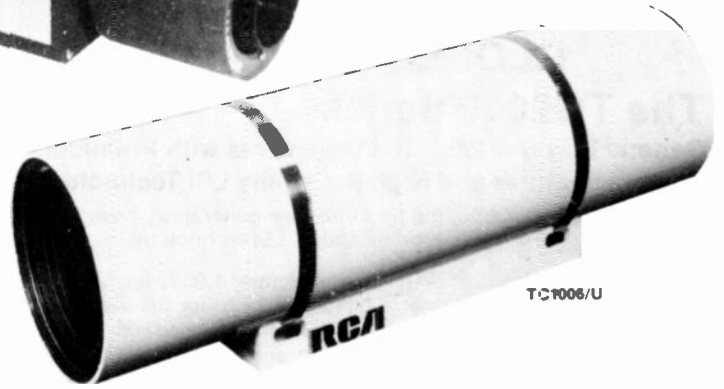
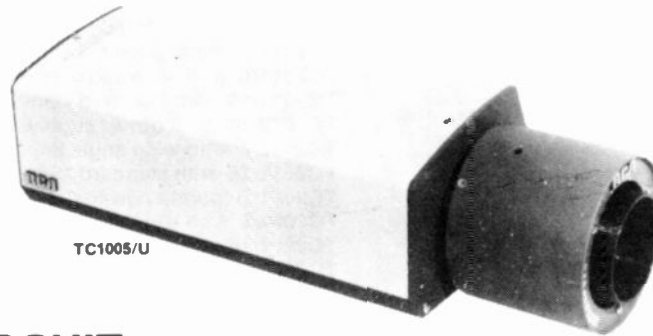

## CLOSED CIRCUIT VIDEO EQUIPMENT

### The TC1005 Series

#### 1" Premium Cameras for the Most Demanding CCTV Applications

TC1005 Series Cameras have been designed to provide both versatility and outstanding performance in the most demanding CCTV applications. Their 1" camera tubes give high sensitivity coupled with high resolution. Premium features include RS-170 sync, 2:1 interlace, phase lock loop, automatic beam control, auto-black and a wide dynamic range. Adjustable video output, and gamma correction, controlled distortion, full drive loss protection, dual video outputs and a wide selection of fixed or zoom lenses or lens/camera systems make them adaptable to a wide variety of the more sophisticated CCTV systems.

#### 1" Camera Tube

##### Scene Illumination†

0.17 fc for usable picture, 0.66 fc for full video with Vidicon.  
0.01 fc for usable picture, 0.043 fc for full video with Ultricon.

##### Resolution 800 lines with Vidicon.

Signal-to-Noise better than 44 dB with Vidicon

##### Sync Out or 3-Way Genlock

##### Adjustable Gamma Correction

##### Low Geometric Distortion

##### Two Independent Video Outputs

##### EIA RS-170 Sync, 2:1 Interlace

##### Phase Lock Loop synchronizes camera to power line.

**Automatic Light Range (ALR)** includes selectable AGC variable gain/bandwidth amplifier in all cameras for increased sensitivity and better signal-to-noise performance at lowest camera light levels. Internally adjustable for peak/average response weighting.

Vidicon Cameras 100,000:1 ATC/AGC includes 10,000:1 auto-target control with target voltage limiting to minimize tube lag and burn.

Ultricon Cameras 660,000:1 ALC/AGC with 1/1.4 to 1/360 auto-iris lens.

##### Automatic Beam Control

##### Auto-Black plus Keyed clamp

##### Camera Tube Positioning Adjustment

Compact cameras, less lens only 3.5 x 5.5 x 11.75"—only 8 lbs.

#### Vidicon Cameras without Lens

TC1005/01 High performance camera, 800 lines resolution, 100,000:1 ALC 1" separate mesh, magnetic focus vidicon, internal RS-170 sync. Accepts external H&V drive, sync or composite video for Genlock. 120 V, 60 Hz ..... \$910.00  
TC1005/01F 24 V, 60 Hz version of TC1005/01 ..... \$910.00

#### Lens Options for Low Light Cameras

**ES Lens Series**—Auto-iris lenses providing performance and economy for a wide range of CCTV applications. Include built-in light path filter that extends upper range to f/360.

##### 2/3" format

TC1810 ES 8.5 mm f/1.5 ..... \$255.00  
TC1816 ES 16 mm f/1.6 ..... \$235.00

##### 1" format (usable on 2/3" camera)

TC1812 ES 12.5 mm f/1.4 ..... \$285.00  
TC1824 ES 25 mm f/1.4 ..... \$260.00  
TC1849 ES 50 mm f/1.8 ..... \$250.00  
TC1874 ES 75 mm f/1.8 ..... \$305.00

#### Low Light Cameras (Optional ES and IS Series lenses as shown)

TC1005/U01 1" Ultricon (silicon target) version of TC1005/01 less lens ..... \$1695.00  
TC1005/U12 With 12.5 mm f1.4 ES Series auto iris lens ..... \$1965.00  
TC1005/U24 With 25 mm f1.4 ES Series auto iris lens ..... \$1940.00  
TC1005/U49 With 50 mm f1.8 ES Series auto iris lens ..... \$1925.00  
TC1005/U74 With 75 mm f1.8 ES Series auto iris lens ..... \$1995.00  
TC1005/U75 With 75 mm f1.8 IS Series auto iris lens ..... \$2315.00

#### Notes:

- For 24 V, 60 Hz. version add suffix "F" to model number (same price).
- For Newvicon camera tube, type 4906, change "U" to "N" in model number (same price).

#### Low Light Level Systems<sup>1</sup>

##### Cameras with Zoom Lens and Auto-Iris Controller, Factory Installed and Adjusted

TC1005/U06 TC1005/U01 Ultricon (Silicon Target) camera with 18-108 mm (6x) f1.8 standard zoom lens with spot filter and separate TC1430 Controller ..... \$2985.00  
TC1005/UR6 Same as TC1005/U06 but with TC1430R Control Unit mounted on camera ..... \$2985.00  
TC1005/U08 Same as TC1005/U06 but with 18-144 mm (8x) f2.0 lens. Includes TC1430 Controller ..... \$3575.00  
TC1005/UR8 Same as TC1005/U08 but with TC1430R Control Unit ..... \$3575.00  
TC1005/U09 Same as TC1005/U06 but with 16-160 mm (10x) f1.8 economy lens. Includes TC1430 Controller ..... \$3915.00  
TC1005/U10 Same as TC1005/U06 but with 16-160 mm (10x) f1.8 lens. Includes TC1430 Controller ..... \$3915.00  
TC1005/UR0 Same as TC1005/U10 but with TC1430R Control Unit ..... \$3915.00  
TC1005/URE Same as TC1005/U06 but with 15-150 mm (10x) f1.8 lens, integral remotely controlled extender (23.5-235 mm, f2.9) and TC1430F Control Unit on camera ..... \$6325.00

The TC1430 Controller is for desk top or rack mount. Use in hard wired systems of up to 1000 ft with one controller per camera.

The TC1430R Control Unit is mounted on the camera. Use in long, hard-wired systems or with twisted-pair control systems. A separate controller such as V100C is required (V108C for URE cameras)

##### Cameras with Auto-Iris Zoom Lens, Factory Installed and Adjusted (No remote iris control)<sup>2</sup>

TC1005/UT6 TC1005/U01 Ultricon (Silicon Target) camera with 18-108 mm (6x) f1.8 standard Auto-Iris Zoom lens ..... \$2775.00  
TC1005/UT8 Same as TC1005/UT6 but with 18-144 mm (8x) f2.0 lens ..... \$3230.00  
TC1005/UT0 Same as TC1005/UT6 but with 16-160 mm (10x) f1.8 lens ..... \$3565.00

### RCA TC1006 Camera Family—Low Light Level Systems<sup>1</sup>

#### Cameras in Environmental Housing, Factory Assembled, Adjusted and Pressurized<sup>3</sup> With Fixed Lens

TC1006/U13 TC1005/U01 camera with 12.5 mm auto iris lens with filters ..... \$2395.00  
TC1006/U25 Same as TC1006/U13 but with 25 mm lens ..... \$2370.00  
TC1006/U50 Same as TC1006/U13 but with 50 mm lens ..... \$2370.00  
TC1006/U75 Same as TC1006/U13 but with 75 mm lens ..... \$2400.00

#### With Zoom Lens<sup>2</sup>

TC1006/U26 TC1005/U01 camera with 18-108 mm (6x) f1.8 zoom lens with spot filter ..... \$3895.00  
TC1006/U28 Same as TC1006/U26 but with 18-144 mm (8x) f2.0 lens ..... \$4420.00  
TC1006/U20 Same as TC1006/U26 but with 16-160 mm (10x) f1.8 lens ..... \$4720.00

#### Notes:

- For Newvicon camera's tube, type 4906, change "U" to "N" in model number (same price)
- "UT-" and "UZ-" cameras require a separate controller such as the V100ZF. If length of run exceeds 1000 ft, use of a relay box or a twisted-pair control system is recommended
- Sunshield, TC1366 available, \$57.00.



TC2011

## VIDEO EQUIPMENT CLOSED-CIRCUIT

### The TC2000 Series

**General Purpose 2/3" CCTV Cameras with Premium Camera Features and High Reliability LSI Technology**

TC2000 Series Cameras, the first in a new generation, have been designed using the latest, high reliability, LSI technology.

- Scene Illumination: 0.25 fc for usable picture, 1.00 fc for full video with Vidicon; 0.03 fc for usable picture, 0.12 fc for full video with Newvicon; 0.02 fc for usable picture, 0.08 fc for full video with Ultricon
- Resolution beyond 600 lines with Vidicon • Signal-to-Noise better than 44 dB • EIA RS-170 Sync, 2.1 interlace • Phase Lock Loop synchronizes camera to power line • Genlock external sync • Automatic Light Range (ALR) includes selectable AGC variable gain/bandwidth amplifier in all cameras for increased sensitivity and better signal-to-noise performance at lowest camera light levels. Internally adjustable for peak/average response weighting • Vidicon Cameras 100,000:1 ATC/AGC includes 10,000:1 auto-target control with target voltage limiting to minimize tube lag and burn
- Ultricon/Newvicon Cameras 660,000:1 ALC/AGC with f/1.4 to f/360 auto-iris lens. Automatic Lens Override (ALO) circuit provides camera-controlled auto-lens response independent of lens setup—eliminates AGC/Auto-Lens interaction and provides smooth, step-free response throughout the camera light range • Automatic beam control • Auto-Black plus keyed clamp • Auto-Track electronic focus • Adjustable Gamma correction • Output level control • Camera tube positioning adjustment and lock • Top or bottom mount • Small size/Light weight camera, less lens, only 3.1 x 4.4 x 7.1"—only 2 lbs • Wide environmental range • Three types of camera tubes • Three supply voltages • Two AC power supply configurations

### RCA TC1500 LOW COST CAMERA FAMILY

2/3 Inch Standard Vidicons, CA #4848  
500 LINE RESOLUTION

Description 2.6 x 4.0 x 8.0 inches Less Lens  
Weigh 2.8 lbs. BNC Connector

- TC1501 Surveillance Camera, 500 lines resolution, 10,000:1 ALC, RS170 sync., 2:1 interlace, 120 V, 60 Hz, 2/3" separate mesh vidicon ..... \$225.00
- TC1502 24 V, 60 Hz version of TC1501 ..... 225.00

### RCA TC2000 RF OUTPUT CAMERA FAMILY

RF Output For Channels 3 or 4 (Switchable)

Includes Other Basic Features of the TC2000 Camera Family

- TC2111 Integral power supply, 120 V, 60 Hz, no lens ..... \$380.00
- TC2112 Integral power supply 24 V, 60 Hz, no lens ..... 380.00
- TC2155/C 12 VDC (10.5-16 VDC) crystal control, no lens ..... 380.00
- TC2111/U\* Ultricon version, 120 V, 60 Hz, no lens ..... 905.00
- TC2112/U\* Ultricon version, 24 V, 60 Hz, no lens ..... 905.00

Notes: For Newvicon camera tube type 4905 (S4075) change "U" to "N" in model number (same price).

\*For ES series auto iris lenses see list on page . Order lens separately. Will be mounted and set-up on camera.

### Standard Vidicon Cameras with Type 8844 Vidicon

MODEL	DESCRIPTION	
TC2011	Integral power supply, 120 V, 60 Hz, no lens	\$325.00
TC2011/8	with wide angle 8mm f1.6 lens (no iris)	400.00
TC2011/16	with standard 16mm f1.6 lens (no iris)	345.00
TC2012	Integral power supply, 24 V, 60 Hz, no lens	325.00
TC2012/8	with wide angle 8mm f1.6 lens (no iris)	400.00
TC2012/16	with standard 16mm f1.6 lens (no iris)	345.00
TC2021	Separate power supply, 120 V, 60 Hz, no lens	325.00
TC2021/8	with wide angle 8mm f1.6 lens (no iris)	400.00
TC2021/16	with standard 16mm f1.6 lens (no iris)	345.00
TC2022	Separate power supply, 24 V, 60 Hz, no lens	325.00
TC2022/8	with wide angle 8mm f1.6 lens (no iris)	400.00
TC2022/16	with standard 16mm f1.6 lens (no iris)	345.00
TC2055/C	12 VDC camera crystal control, no lens	325.00
TC2055/8C	with wide angle 8mm f1.6 lens (no iris)	400.00
TC2055/16C	with standard 16mm f1.6 lens (no iris)	345.00

NOTE: For crystal control add suffix "C" to model number and \$9.00 (Except TC2055 Series)

### Low Light Level Cameras—Optional ES Series Lens as shown and Ultricon Camera Tube—Type 4833U (For Newvicon Camera Tube - see note 2 below)

MODEL	DESCRIPTION	
TC2011/U	Integral power supply, 120 V, 60 Hz	\$ 855.00
TC2011/U8	with 8.5mm f1.5 auto iris lens	1100.00
TC2011/U12	with 12.5mm f1.4 auto iris lens	1110.00
TC2011/U16	with 16mm f1.6 auto iris lens	1080.00
TC2011/U25	with 25mm f1.4 auto iris lens	1085.00
TC2011/U50	with 50mm f1.8 auto iris lens	1085.00
TC2011/U75	with 75mm f1.8 auto iris lens	1130.00
TC2011/UZ6	with 12.5-75mm (6x) f1.8 zoom lens	1680.00
TC2011/UZ0	with 11-110 (10x) f2.0 zoom lens	2270.00
TC2012/U	Integral power supply, 24 V, 60 Hz	855.00
TC2012/U8	with 8.5mm f1.5 auto iris lens	1100.00
TC2012/U12	with 12.5mm f1.4 auto iris lens	1100.00
TC2012/U16	with 16mm f1.6 auto iris lens	1080.00
TC2012/U25	with 25mm f1.4 auto iris lens	1085.00
TC2012/U50	with 50mm f1.8 auto iris lens	1085.00
TC2012/U75	with 75mm f1.8 auto iris lens	1130.00
TC2012/UZ6	with 12.5-75mm (6x) f1.8 zoom lens	1680.00
TC2012/UZ0	with 11-110 (10x) f2.0 zoom lens	2270.00
TC2021/U	Separate power supply, 120V, 60 Hz	855.00
TC2021/U8	with 8.5mm f1.5 auto iris lens	1100.00
TC2021/U12	with 12.5mm f1.4 auto iris lens	1110.00
TC2021/U16	with 16mm f1.6 auto iris lens	1080.00
TC2021/U25	with 25mm f1.4 auto iris lens	1085.00
TC2021/U50	with 50mm f1.8 auto iris lens	1085.00
TC2021/U75	with 75mm f1.8 auto iris lens	1130.00
TC2021/UZ6	with 12.5-75mm (6x) f1.8 zoom lens	1680.00
TC2021/UZ0	with 11-110 (10x) f2.0 zoom lens	2270.00
TC2022/U	Separate power supply, 24 V, 60 Hz	855.00
TC2022/U8	with 8.5mm f1.5 auto iris lens	1100.00
TC2022/U12	with 12.5mm f1.4 auto iris lens	1110.00
TC2022/U16	with 16mm f1.6 auto iris lens	1080.00
TC2022/U25	with 25mm f1.4 auto iris lens	1085.00
TC2022/U50	with 50mm f1.8 auto iris lens	1085.00
TC2022/U75	with 75mm f1.8 auto iris lens	1130.00
TC2022/UZ6	with 12.5-75mm (6x) f1.8 zoom lens	1680.00
TC2022/UZ0	with 11-110 (10x) f2.0 zoom lens	2220.00
TC2055/U	12 VDC camera (10.5-16 VDC) crystal control	855.00
TC2055/U8C	with 8.5mm f1.5 auto iris lens	1100.00
TC2055/U12C	with 12.5mm f1.4 auto iris lens	1110.00
TC2055/U16C	with 16mm f1.6 auto iris lens	1080.00
TC2055/U25C	with 25mm f1.4 auto iris lens	1085.00
TC2055/U50C	with 50mm f1.8 auto iris lens	1085.00
TC2055/U75C	with 75mm f1.8 auto iris lens	1130.00

NOTE: 1. For crystal control add suffix "C" to model number (TC2055 is crystal only) and \$9.00 to cost. Crystal Control models do not have Line Locked feature.

2. For Newvicon camera tube, type 4905, change "U" to "N" in model number (same price).

3. For "UZ-" cameras use V100ZF controller.

4. TC1000 and TC2000 Series and Monitors may be combined to obtain the best quantity price.

CAN BE ORDERED 50/60 CYCLE 110/220V OPERATION  
Prices and Specifications Subject to Change Without Notice.



## CLOSED-CIRCUIT VIDEO EQUIPMENT

### The TC1004 Series

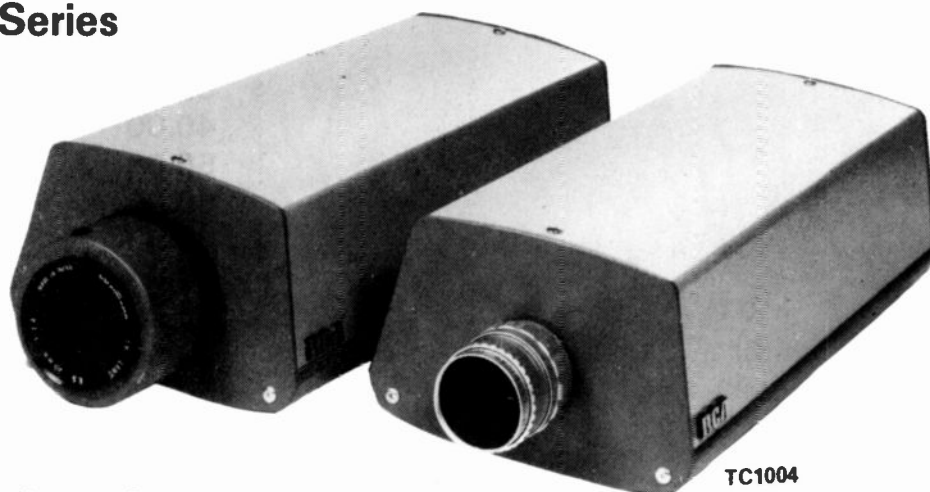

#### Economical 1" General Purpose Cameras

- 1" Camera Tube. Separate mesh, magnetic focus and deflection
- Scene Illumination (f/1.4 lens, 75% highlight reflectance)
  - 0.34 fc for usable picture. 1.32 fc for full video with Vidicon
  - 0.03 fc for usable picture. 0.12 fc for full video with Newvicon
  - 0.02 fc for usable picture. 0.08 fc for full video with Ultricon
- Resolution 700 TVL or better
- Signal to Noise better than 44dB
- Auto-Track Electronic Focus
- EIA RS-170 Sync. 2:1 Interlace
- Phase Lock Loop
- Genlock
- Auto-Black Plus Kaged Clamp
- Automatic Light Range
  - Vidicon 50,000:1
  - Ultricon/Newvicon 330,00:1 (f/1.4 to f/360 auto iris lens)

### RCA TC1030/H SIT Cameras for Very Low Light Levels



All the features of the TC1005 family plus—useful pictures with as little as quarter moonlight

- Scene illumination:
  - 3.3 x 10<sup>-4</sup> fc for usable picture
  - 1.0 x 10<sup>-3</sup> fc for full video
- RCA Low Bloom, Silicon Intensifier Target (SIT) Tube
- 100 Million:1 ALR with f/1.4 auto-iris lens
- Resolution 600 lines
- High voltage power supply integral with tube
- Built-in SIT tube protection

### RCA TC1040/H ISIT Cameras

For Ultra Low Light Levels scene illumination as low as 2.7 x 10<sup>-5</sup>. Price on request.

#### STANDARD VIDICON CAMERAS (Supplied less lens)

TC1004/01 120V, 60 Hz ..... \$550.00

#### LOW LIGHT CAMERAS (Optional ES Series lens as shown)

TC1004/U01 1" Ultricon (Silicon target) (less lens) ..... \$1190.00  
 TC1004/U12 with 12.5 mm f 1.4 auto iris lens ..... 1475.00  
 TC1004/U24 with 25mm f 1.4 auto iris lens ..... 1455.00  
 TC1004/U49 with 50mm f 1.8 auto iris lens ..... 1455.00  
 TC1004/U74 with 75mm f 1.8 auto iris lens ..... 1500.00

Notes: 1) For 24V, 60 HZ version add "F" to model number (Same Price) 2) For Newvicon tube, change "V" to "N" in model number (Same price)

TC1030/H06 Includes 18-108 mm (6z) f1.8 zoom/auto-iris lens with spot filter and separate TC1430 lens controller \$7160.00  
 TC1030/HR6 Same as TC1030/H06 except includes TC1430R control unit 7160.00  
 TC1030/H08 Same as above with 18-144 mm (8x) f2.0 zoom/auto-iris lens and TC1430 controller 7650.00  
 TC1030/HR8 Same as TC1030/H08 except includes TC1430R control unit 7650.00  
 TC1030/H10 Same as above with 16-160 mm (10z) f1.8 zoom/auto-iris lens and TC1430 controller 8625.00  
 TC1030/HR0 Same as TC1030/H10 except includes TC1430R control unit 8625.00  
 TC1030/HRE Includes 15-150 mm (10x) f1.8 lens, with integral remotely controlled extender (23.5-235 mm f2.9) and TC1430R control unit on camera. Use V108C controller 10,000.00  
 spot filter 6900.00  
 TC1030/H25 Same as above with 25 mm f1.4 fixed lens 6825.00  
 TC1030/H50 Same as above with 50 mm f1.4 fixed lens. 6825.00  
 TC1030/H75 Same as above with 75 mm f1.8 fixed lens 6900.00  
 TC1030/H Available on special order for use in constant low light level applications 6650.00  
 TC1036/H13 TC1030 in environmental housing, with 12.5 mm fixed focal length auto-iris lens 7500.00  
 TC1036/H25 Same as above with 25 mm fixed lens 7415.00  
 TC1036/H50 Same as above with 50 mm fixed lens 7415.00  
 TC1036/H75 Same as above with 75 mm fixed lens 7500.00  
 TC1036/HZ6 TC1030 in environmental housing with 18-108 mm (6x) zoom lens 7720.00  
 TC1036/HZ8 Same as above with 18-144 (8x) zoom lens 8170.00  
 TC1036/HZ0 Same as above with 16-160 (10x) zoom lens 9180.00

## RENTAL RATES

	Day	Week	Monthly*
1/2" Portable	\$ 50.00	\$ 150.00	
1/2" Player	40.00	120.00	
1/2" Recorder	50.00	150.00	
3/4" Player	50.00	150.00	
3/4" Recorder	60.00	180.00	
3/4" Editor	150.00	450.00	
3/4" Portable	75.00	225.00	
3/4" Editing System w/Controller	300.00	900.00	
1" Portable	450.00	1350.00	
Single tube-port. GP-5A, WV-3320, WV-3200	50.00	150.00	
Single tube-port. high end WV-3890	100.00	300.00	
Three tube-port. AK-710/FP-40	225.00	675.00	
AK-760/SK-91/XC700	300.00	900.00	
SK-80	250.00	750.00	
Three tube-studio FP-60	300.00	900.00	
9" B/W monitors	15.00	45.00	
5-12" Color monitor	25.00	75.00	
19" Color receiver	25.00	75.00	
6' Projection television	200.00	600.00	
25" monitor/receiver	40.00	120.00	
Electrohome	225.00	495.00	
TBC 1700D, T120	200.00	600.00	
Character Generator	75-200.00	225-600.00	
Tripods, lightweight	5.00	15.00	
Tripods	20.00	60.00	
Mics.	10.00	30.00	
Mixers	20.00	60.00	
Lights (3)	25.00	75.00	
Carts	10.00	15.00	
Cables video and audio	.10/ft.	.30/ft.	

\*Monthly rate = 2½ x weekly





MODEL BP 300L/BP300



MODEL SPK300

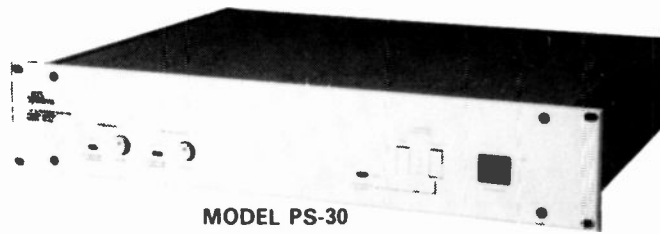

MODEL PS-30

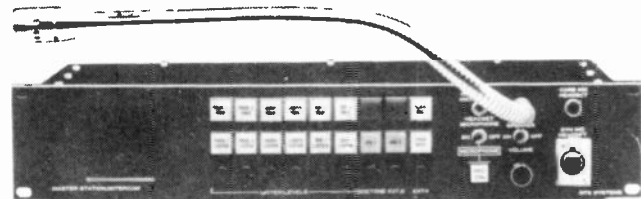

MODEL 801 MASTER STATION

### "TW" INTERCOM SYSTEM

The "TW" Intercom System is a high performance, closed circuit intercommunications system designed for use in entertainment and industrial operations. Proven performance in a variety of demanding applications has already established it as a standard in the field of communications.

#### MODEL BP300L/BP300 PORTABLE USER STATIONS (BELT PACKS)

RTS super-rugged belt packs are housed in an attractive light-weight aluminum package with a brushed, anodized finish and a wide belt clip. They feature two-channel operation, a mic On-Off switch, XLR-3 connectors for use with standard mic cables, and a powerful 2-watt headphone amplifier that enables any type of headset to be used; low Z or high Z phones, with dynamic or carbon mic.

Belt pack human engineering features include a built-in mic limiter for controlling levels, and tactile controls for ease of operation. The belt packs are truly portable, but may also be used in semi-portable or fixed applications.

BP300L (with call light)	\$297.00
BP300 (without call light)	252.00

#### MODEL SPK 300 SPEAKER UNIT USER STATION

RTS portable speaker unit user stations are mounted in sloped front aluminum enclosures with epoxy paint finish. The speaker is activated by the insertion of a desk-stand mic or a hand-held PTT mic. When a headset or handset is used instead of a mic, the speaker is automatically deactivated, allowing conventional operation. A rear mounted sidetone control cancels the mic signal in the speaker so that simultaneous operation of the microphone and speaker is possible.

\$381.00

#### POWER SUPPLIES

Model PS-8 Power Supply 8 station power supply, portable or rack-mount.	\$378.00
Model PS-30 Power Supply 30 station power supply, rack-mount.	\$984.00
Model PS-60 Power Supply 60 station power supply, rack-mount.	\$1923.00

#### MODEL 801

The Model 801 Master Station is a multi-functional communications control center. It is designed for use where multi-channel party line intercommunication systems are utilized. It may be used to supplement existing intercom systems, e.g., RTS "TW" System, Clear Com, Daven, RCA, etc., or a number of Master Stations may be employed as a self-contained system.

The 801 is operationally flexible; it offers many salient features as well as simplicity in design and installation. Each unit is completely self-contained—there are no extra modules, central card frame, or processing units.

\$3951.00

#### MODEL 860 SYSTEM INTERCONNECT

The Model 860 System Interconnect is used to supplement the Model 801 Master Station system. It provides the following capabilities and functions:

- Eight Amphenol 50-pin connectors for point source interconnect to Master Stations
- Connects six intercom channels to RTS "TW" System
- IFB/SA outputs
- IFB/SA keying line outputs (relay contacts)
- Interfacing to external circuits
- Switching and level control for four program inputs to iFB and SA circuits
- Standard rack mount package—3 1/2" x 19" x 14" \$1200.00

#### ADDITIONAL EQUIPMENT

RM300	Rack Mount User Station	\$285.00
RM300L	Rack Mount User Station	342.00
SCR-110	Special Camera User Station	297.00
SPK300L	Speaker Unit User Station	423.00
SPK300	Speaker Unit User Station	381.00
BP320	Portable User Station—Belt Pack	456.00
BP320L	Portable User Station—Belt Pack	498.00
RMS300	Speaker Station (Rack Mount)	522.00
RMS300L	Speaker Station (Rack Mount)	591.00
CM300L	Console Mount User Station	357.00
CM300	Console Mount User Station	297.00
WM300L	Wall Mount User Station	315.00
WMS300L	Wall Mount User Station	384.00
TWI-224	2-Wire to 4-Wire Interface	423.00
TW-5W	Passive Splitter	81.00
CC61	Circuit Card	144.00
CC-40	Circuit Card	180.00
FS-1	Footswitch	30.00

## AMPS/PREAMPS



405



410



444

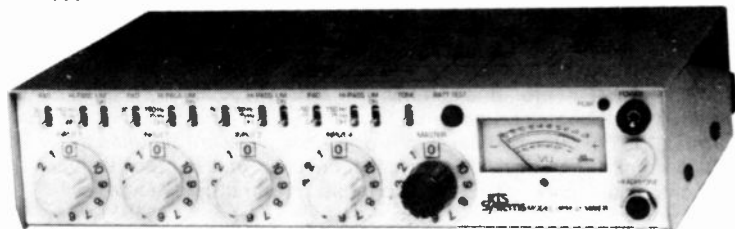

HPM-41

### MODEL 405 PROFESSIONAL 2-CHANNEL PHONO PREAMPLIFIER

The Model 405 is a high-quality two-channel phono preamplifier designed for professional applications, including disc mastering rooms, broadcast stations and high quality commercial installations. It features adjustable cartridge termination, switchable rumble filter, two selectable sets of level controls and two output formats. **\$378.00**

### MODEL 410 10 WATT MONITOR AMPLIFIER

The Model 410 is a self-contained compact 10 watt power amplifier designed to power loudspeakers, headphones or 70-volt loudspeaker distribution systems. Its input is balanced and designed to bridge 600 ohm / +4 dBu program lines. The 410 features a front panel volume control and two separate outputs: a direct amplifier output available on push terminals and/or 1/4-inch phone jack, and an optional transformer isolated output on a barrier strip, for 70-volt distribution. The input connection may be made via a 3-pin XLR type connector and/or 1/4-inch phone jack. **\$288.00**

### MODEL 444 DUAL 2-CHANNEL BUFFER AMPLIFIER

The Model 444 is a dual, two-channel buffer amplifier designed to interface professional systems with semi-pro and home high-fidelity equipment. Although components designed for home use offer desirable features for studio applications, interconnections between the two kinds of equipment are complicated by differences in levels, impedances and balanced and unbalanced modes of operation. The 444 corrects these problems while maintaining signal integrity. **\$342.00**

## MIXER

### HPM-41

The Model HPM-41 microphone mixer is a compact, lightweight unit, designed for professional applications ranging from location film and tape to major recording console input augmentation. A no-compromise design provides high performance electronic circuitry in a functionally efficient, durable package.

#### INPUT FEATURES

- Four balanced, transformer-isolated input positions with phase reverse switches and high quality Neutrik XLR-type connectors
- Switchable 12 V A-B and 48 V phantom power for condenser microphones
- Selectable pre-transformer pads for reduction of input levels
- Switchable dual-frequency high pass filters to cut rumble, wind noise, and pops
- Switchable limiter on each input prevents overdrive distortion without affecting other channels
- Auxiliary unbalanced line level input

#### OUTPUT FEATURES

- Balanced (floating) 600-ohm output available on binding posts for TelCo (telephone) feeds
- Balanced (floating) low impedance output on XLR-type connector is switchable between line and microphone level
- Powerful headphone amplifier with front panel volume control and output jack
- Two independent IHF line-level outputs available to feed external equipment such as: video cassettes, audio cassettes, consumer audio gear, etc. **\$996.00**

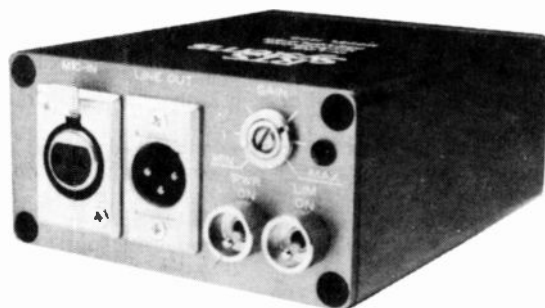

1400

The RTS 1400 is more than a microphone preamplifier; it is a unique and versatile tool. Its well-planned features, rugged construction and excellent specifications make it a professional problem solver, an audio "adapter" with countless applications.

The 1400's gain is continuously variable via a front panel control. At lower gain settings (minimum 23 dB) the 1400 will boost the level from a low-output microphone to drive low-gain mixers at their specified nominal level. At higher gain settings (56 dB maximum), the 1400 has ample gain to boost a mic output to line level. Because the 1400 has a high quality built-in limiter, it can be used to prevent overdrive of individual mic (or line) inputs while maintaining high average levels. These features make it useful in fixed or portable sound reinforcement, location recording, remote broadcasting, and broadcast production.

- Low Noise — 127 dBv E.I.N.
- Variable Gain 23-56 dB
- High Output Capability + 16 dBm
- Limiter
- Low Distortion .006% typ.
- Excellent Transient Response **\$297.00**

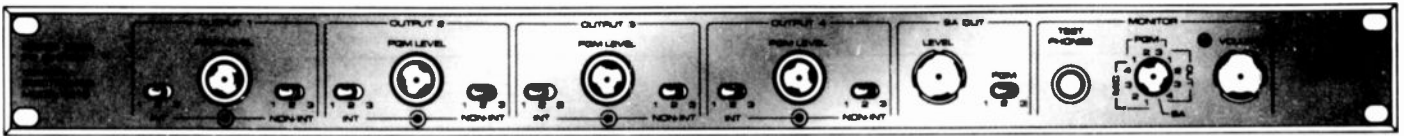

4010

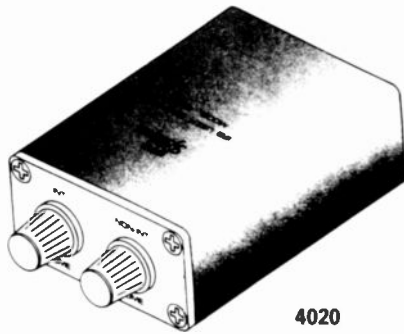

4020

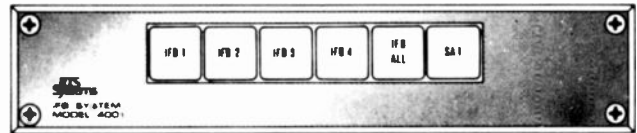

4001

### CONTROL STATION MODELS 4001, 4002, 4003 4001M, 4002M, 4003M

The Control Station is designed to mount in a console or equipment rack. It provides a given number of switch functions according to the model number. The 4001 offers IFB 1 thru IFB 4, IFB ALL and SA. The 4002 has IFB 1 thru IFB 8, IFB ALL, SA 1 and SA 2. Model 4003 supplies IFB 1 thru 12, IFB ALL, SA 1, SA 2 and SA 3. Each model number may be ordered with an "M" suffix. This includes a gooseneck microphone attached to the panel. Should an existing microphone be more suitable for operations, a connection on the Control Station microphone preamp circuit board may be used to accept a microphone or line level signal from that microphone.

Each Control Station is connected to the Central Electronics via a model 4025 Splitter and 50 conductor cable with blue ribbon connectors. All the Control Stations converge at the 4025 and a single cable then connects to the 4010. This configuration allows for up to four model 4001 Control Stations to connect to a single Central Electronics unit. If two Central Electronics units are used, the model 4002 may be employed in up to four locations. Three 4010's would require up to four model 4003 Control Stations. Priority of Control Station switch signals is programmable and may be set-up at the time of installation. The system may be used without priority switching if desired.

**4001.** A four-channel CONTROL PANEL with IFB-1, IFB-2, IFB-3, IFB-4, ALL-CALL and SA. **\$489.00**

**4001M.** Model 4001 with gooseneck microphone. **654.00**

**4002.** An eight-channel CONTROL PANEL with IFB-1 thru IFB-8, ALL-CALL, SA1 and SA2. **\$618.00**

**4002M.** Model 4002 with gooseneck microphone. **783.00**

**4003.** A twelve-channel CONTROL PANEL with IFB-1 thru IFB-12, ALL-CALL, SA1, SA2, and SA3. **\$756.00**

**4003M.** Model 4003 with gooseneck microphone. **921.00**

**4010.** CENTRAL ELECTRONICS for four channels of IFB, providing all switching, level adjustments and program inputs. Eight IFB channels require two 4010's. Twelve IFB channels require three 4010's. **\$1983.00**

**4015.** CABLE ASSEMBLY. XX Foot, 50-Conductor cable with connectors. To calculate price, multiply the number of feet times **\$1.88** and add **\$30.00** for connectors and assembly.

**4020.** This USER STATION belt pack is the "talent" position electronics. A minimum of one is required for each channel of IFB. A maximum of three can be used on each channel. **\$297.00**

**4025.** SPLITTER ASSEMBLY. One-by-four, 50-conductor "Blue Ribbon" connectors. **\$141.00**

### SYSTEM DESCRIPTION

This IFB System is a one-way interruptible feedback communications system (a program interrupt system) created especially to meet the critical requirements of the television broadcast industry, as well as other live or recorded media applications. The system is comprised of User Stations, Central Electronics, and Control Panels. A modular approach allows each installation to be configured in a manner which best lends itself to the immediate requirements. Should the production requirements increase in complexity, additional system components may be added on to expand the system capability. A typical system may consist of the following: up to four Control Panels, one Central Electronics unit, four User Stations, and assorted cabling and interconnect units. The maximum standard configuration allows four Control Panels, three Central Electronics, and twelve User Stations.

### MODEL 4010 CENTRAL ELECTRONICS

The Central Electronics unit contains all the necessary control functions and electronics to provide the active link between the Control Station and the User Station. It accepts the three program inputs, the four microphone inputs and switch keying signal inputs (from the Control Stations). In addition, it supplies the composite output feeds to the User Station belt packs, the line level audio feeds to the SA amplifier, the relay contacts for monitor muting, and the interconnection to the Control Stations. **\$1983.00**

### MODEL 4020 USER STATION

The User Station, a small "belt pack" package, allows the talent to receive the audio signals designated by the Central Electronics and the Control Stations and may be worn by talent, such as newscasters, musicians, sportscasters, etc. Behind the scenes personnel may also find the IFB feeds useful for production coordination and control. Each belt pack contains the necessary electronics to provide a stereo audio signal to the user. **\$297.00**

Product #	Product Name	Description	Size	Price
<b>TO CONVERT DAYLIGHT</b>				
140	Rosco Sun 85	Standard window correction in extra wide rolls for seamless installation. Optically clear.	58 wide 100 sq ft	\$ 90.00
340	Rosco Sun CTO	Use where heavy correction is desired for warm tones. Reduces 5500 K to 3100 K. Optically clear (Rosco Plus 85).	58 wide 100 sq ft	\$ 90.00
3408	Rosco Sun 1/2 CTO	Use where slight correction is desired. Reduces 5500 K to 3800 K. Optically clear (Rosco Lite 85).	58 wide 100 sq ft	\$ 90.00
1409	Rosco Sun 1/2 CTO	Reduces 5500 K to 4500 K. Windows have a blue appearance. Optically clear (Rosco Half 85).	58 wide 100 sq ft	\$ 90.00
3761	Rosco 85	Optically clear rigid panels of 1/4 acrylic resin.	51 x 100	\$140.00
<b>TO REDUCE THE INTENSITY OF DAYLIGHT</b>				
3402	Rosco Sun N3	Reduces light intensity 1 stop. Optically clear. Extra wide.	58 wide 100 sq ft	\$ 90.00
1403	Rosco Sun N6	Reduces light intensity 2 stops. Optically clear. Extra wide.	58 wide 100 sq ft	\$ 90.00
1404	Rosco Sun N9	Reduces light intensity 3 stops. Optically clear. Extra wide.	58 wide 100 sq ft	\$ 90.00
1742	Roscoflex N3	Reduces light intensity 1 stop. Optically clear rigid panels.	51 x 100	\$140.00
1743	Roscoflex N6	Reduces light intensity 2 stops. Optically clear rigid panels.	51 x 100	\$140.00
3405	Rosco Sun 85N3	Reduces light 1 stop and converts. Optically clear. Extra wide.	58 wide 100 sq ft	\$ 95.00
3406	Rosco Sun 85N6	Reduces light 2 stops and converts. Optically clear. Extra wide.	58 wide 100 sq ft	\$ 95.00
3809	Roscoflex N9	Perforated material. Reduces light 2 stops.	54 wide 100 sq ft	\$ 90.00
<b>TO CONVERT 3200 K TO DAYLIGHT (Boost Kelvin Temperature of Lights)</b>				
3202	Tough Blue 50	Boosts 3200 K to daylight. Tough, high heat resistant base. Standard daylight correction.	54 wide 100 sq ft	\$ 95.00
3204	Tough Booster Blue	Increases K 900 degrees. Tough, high heat resistant base.	54 wide 100 sq ft	\$ 95.00
3206	Tough 1/2 Booster Blue	Increases K 600 degrees. Tough, high heat resistant base.	54 wide 100 sq ft	\$ 95.00
3208	Tough 1/3 Booster Blue	Increases K 300 degrees. Tough, high heat resistant base.	54 wide 100 sq ft	\$ 95.00
3216	Tough 1/3 Booster Blue	Increases K 150 degrees. Tough, high heat resistant base.	54 wide 100 sq ft	\$ 95.00
3210	Tough TD25	Converts 3200 K to over 6000 K. Tough base. Heavier correction than Tough Blue. Use where cool daylight is desired.	54 wide 100 sq ft	\$ 95.00
<b>TO SOFTEN AND DIFFUSE LIGHT</b>				
3002	Soft Frost	Soft white diffusion. May be stretched on frames. Place at a distance from high temperature lights.	54 wide 100 sq ft	\$ 40.00
3003	Wide Soft Frost	Same as Soft Frost, extra wide for large area diffusion.	72 wide 150 sq ft	\$ 60.00
3004	Half Density Soft Frost	Similar to Soft Frost, but less dense. May be stretched on frames.	54 wide 100 sq ft	\$ 40.00
3014	White	High transmission, laminar embossed surface. Ideal for lighting and large area diffusion.	55 wide 100 sq ft	\$105.00
3016	White	Wetset Goube emb roll.	110 wide to order sq ft	\$ 1.25
3018	White	Fabricated Screens.	100 ft x 100 ft	\$ 3.95
3000	Tough Roux	Dense white diffusion. Tough. May be used directly on lights.	45 wide 100 sq ft	\$ 65.00
3004	Tough Spin	Effect of spun glass without particle creation. Tough base.	50 wide 100 sq ft	\$ 65.00
3007	Light Tough Spin	Similar to Tough Spin but less dense.	50 wide 100 sq ft	\$ 65.00
3008	Tough Frost	Soft even light. For use on hot lights.	48 wide 100 sq ft	\$ 65.00
3009	Light Tough Frost	Less dense than Tough Frost.	48 wide 100 sq ft	\$ 55.00
3010	Open Tough Frost	Less dense than Light Tough Frost.	48 wide 100 sq ft	\$ 65.00
3011	Tough Silk	Effect of silk with high resistance. Spreads the light.	54 wide 100 sq ft	\$ 65.00
3012	Tough Booster Silk	Combines Tough Silk and Quarter Booster Blue. 300 K increase.	54 wide 100 sq ft	\$ 75.00
3025	Tough 1/2 Booster Frost	Combines Tough Frost and 1/2 Booster Blue. Increases K 150 degrees.	54 wide 100 sq ft	\$ 75.00
3011	Tough Booster Frost	Combines Tough Frost and Half Booster Blue. 600 K increase.	54 wide 100 sq ft	\$ 75.00
3011	Tough Blue 50 Frost	Combines Tough Frost and Blue 50 Correction.	54 wide 100 sq ft	\$ 85.00
3020	Tough White Diffusion	Matte white diffusion for use on lights or bounce effects.	48 wide 100 sq ft	\$ 65.00
3019	Cinege Diffusion A	Sheets 10 x 12 of the Cinege Diffusion material for testing.		\$ 10.95
	Roscoflex Diffusion	High temperature diffusion developed for television lighting.		
		11100 Frost	11113 Matte Silk	11121 Blue Diffusion
		11101 Light Frost	11114 Hamburg Frost	11122 Green Diffusion
		11111 Tough Roux	11120 Red Diffusion	11123 Amber Diffusion
			Sheets 20 x 24	\$ 3.95
			Rolls 24 wide 100 sq ft	\$ 99.50
3020	Diffusion Test Kit	22 sheets of 10 x 12 of the full range of Roscoflex Diffusion for testing.		\$18.95
<b>TO MATCH DAYLIGHT, DICHROICS, OR 3200K LIGHT TO FLOURESCENTS (Cool White or Daylight)</b>				
3304	Windowgreen Tough Plusgreen	Converts natural daylight to match cool white or daylight fluorescents. Use with overall fluorescent correction at lens or in tap. Also converts dichroics or FAY lamps to match fluorescent lights.	54 wide 100 sq ft	\$ 95.00
3306	Tough Plusgreen 50	Converts 3200 K light sources to match fluorescent light. Use with overall fluorescent correction.	54 wide 100 sq ft	\$ 95.00
<b>TO MATCH COOL WHITE OR DAYLIGHT FLOURESCENTS TO DAYLIGHT OR 3200 K LIGHTS</b>				
3308	Tough Minusgreen	Filters green cast from fluorescents for daylight balance. Cool white or daylight lamps become daylight sources.	54 wide 100 sq ft	\$ 95.00
3310	Fluorolite	Corrects cool white fluorescent lamps to 3200 K and filters out green cast.	54 wide 100 sq ft	\$ 95.00
3311	Fluorolite	Available in sleeves for 4 ft or 8 ft lamps.	4 sleeve	\$ 6.00
3312	Fluorolite		8 sleeve	10.00
<b>TO FILTER CARBON ARCS AND HMI LIGHTS</b>				
3106	Tough MTY	For correcting arcs and HMI to 3200 K. Replaces traditional MT2 and Y1 combination in one sheet.	54 wide 100 sq ft	\$ 95.00
3102	Tough MT2	Use with Y1 to correct color temperature of white flame carbon arcs to 3200 K. Heat resistant base.	54 wide 100 sq ft	\$ 95.00
3123	Cine MT2	Use with Y1 to correct color temperature of white flame carbon arcs to 3200 K. Acetate base.	30 wide 100 sq ft	\$ 70.00
3103	Cine MT2 1/2	Half the reduction of MT2. Acetate base.	30 wide 100 sq ft	\$ 75.00
3107	Tough Y1	Absorbs U.V. and reduces Kelvin for daylight balance.	30 wide 100 sq ft	\$ 75.00
3108	Cine Y1	Absorbs U.V. and reduces Kelvin for daylight balance. Acetate base.	30 wide 100 sq ft	\$ 70.00
3108	Tough YF	Balances yellow flame carbons. Tough, heat stable base.	30 wide 100 sq ft	\$ 75.00
3112	Cine YF	Balances yellow flame carbons.	30 wide 100 sq ft	\$ 70.00
3113	Cine YF 101	Balances yellow flame carbons. Acetate base.	30 wide 100 sq ft	\$ 70.00
3110	Tough YF Green	For use on arcs with white flame carbons.	30 wide 100 sq ft	\$ 75.00
3115	Tough 1/2 MT2	Half the reduction of MT2. Tough, heat resistant base.	54 wide 100 sq ft	\$ 95.00
3116	Tough 1/3 MT2	Pale amber correction for arcs and HMI's.	54 wide 100 sq ft	\$ 95.00
3134	Cine S4	Absorbs U.V. and reduces Kelvin for daylight balance. Acetate base.	30 wide 100 sq ft	\$ 70.00
<b>REFLECTION MEDIA</b>				
3801	Roscoflex M	Bright mirror surface for long throw.	54 wide 100 sq ft	\$ 75.00
3802	Roscoflex H	Hard. Matches standard hard side of reflector boards.	54 wide 100 sq ft	\$ 75.00
3803	Roscoflex S	Soft. Similar to standard soft/reflector boards.	54 wide 100 sq ft	\$ 75.00
3804	Roscoflex SS	Super soft. More diffuse than standard soft side.	54 wide 100 sq ft	\$ 75.00
3805	Roscoflex G	Good for soft warm reflection.	54 wide 100 sq ft	\$ 75.00
3806	Roscoflex C	Cool Blue. Reflects without Kelvin loss.	54 wide 100 sq ft	\$ 75.00
3807	Roscoflex D	Shiner blue surface. Reflects and boosts 3200 K light to daylight.	54 wide 100 sq ft	\$ 75.00
3808	Roscoflex F	Virtually weightless. Shiner. Tissue thin, yet strong and durable.	54 wide 100 sq ft	\$ 75.00
3810	Roscoflex W	White reflector with shiner back. Light weight, yet durable.	54 wide 100 sq ft	\$ 75.00
8503	RoscoFlex D	18 sq ft of daylight reflector packed in handy plastic pouch.	18 sq ft	\$ 15.00
8508	RoscoFlex G	18 sq ft of good reflector packed in handy plastic pouch.	18 sq ft	\$ 15.00
8508	RoscoFlex F	18 sq ft of Roscoflex F packed in handy plastic pouch.	18 sq ft	\$ 15.00
8502	RoscoFlex W	18 sq ft of Roscoflex W packed in handy plastic pouch.	18 sq ft	\$ 15.00
3809	Roscoflex M	Perforated material. Reduces light 2 stops.	54 wide 100 sq ft	\$ 90.00
3811	Roscoflex W	Opaque. Tough. Light polyester.	60 wide 100 sq ft	\$ 13.50
8202	Roscobond	Pressure sensitive adhesive for bonding Roscoflex media to aluminum or other non-porous surfaces.	1 quart	\$ 6.75
8203	Roscobond		1 gallon	21.50
<b>COLOR MEDIA FOR LIGHTING EFFECTS-SWATCHBOOKS</b>				
	Roscoflex	Tough, the most heat resistant color effects media. Available in 104 colors.	20 x 24	\$ 4.25
8808	Cinege Switchbook	A Switchbook containing samples of every Cinege medium.		2.50
8807	Roscoflex Switchbook	A book containing a sample of every Roscoflex color.		2.50
	Cineflex	Wide width rolls of effects colors and diffusers. 51 colors.	48 wide 100 sq ft	\$ 99.00
		Nine diffusers. Color # 102 103 104 105 106 111.	48 wide 100 sq ft	66.00
		Color # 107 108 109.	48 wide 100 sq ft	82.00
8811	Cineflex Switchbook	A book containing a sample of every Cineflex color and diffuser.		2.50

### This New Case is Changing 3/4" Videocassette Storage and Handling Throughout the Industry.

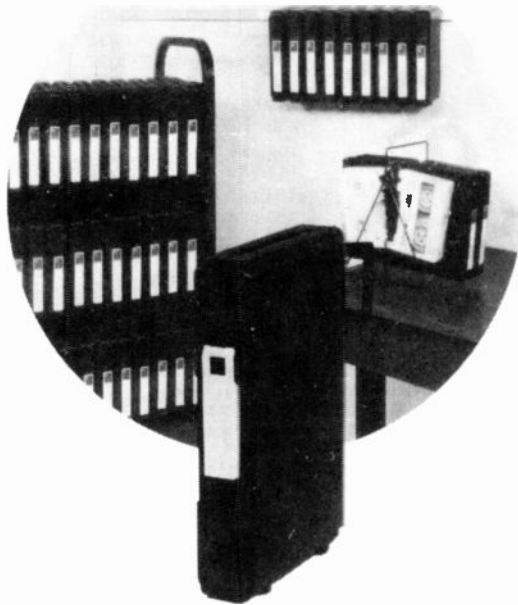

**It's at the Center of the All-New "Scotch" Hanger System, Designed to Make Your Tape Storage and Handling Faster, Easier and More Systemized.**

You're looking at the videocassette case design that's triggered a revolution in 3/4" videocassette storage and handling — it's at the focal point of the all new "Scotch" Hanger System from 3M Company. The shipper/storage case (patents applied for) represents a whole new design concept based upon the idea that hanging your videocassettes not only is the best way to protect them from damage, but it will organize your storage area and simplify the way you transport videocassettes. So, "hang on" with the "Scotch" Hanger System.

**Individual system components available separately so you can tailor the system to your needs:**

**Shipper/Storage Case (C-125) \$3.00 each**

This sturdy C-125 box can be labeled and mailed with no other packaging needed. Its unique hanging hook and slide-snap latch are only two of the features of this case that opens to also reveal a recess for storing the record-lockout button when you are not using the record mode. The stabilizer bars on the box bottom and the expandable, spine-handle simplify storage and retrieval in any situation.

**Case Hanger (CHB-4) \$4.88/4 ft. length**

This extruded aluminum bar comes in four-foot lengths and can be cut to fit doors, desk backs, cabinets, shelves, walls, etc. Standard screws or bolts anchor them securely to concrete, wood, plaster or metal surfaces, and when properly mounted, the bars can maintain weights of up to 240 pounds. We call it the Case Hanger.

**Cassette Hanger (CHH-10) \$2.43/Bag of 10**

In order to handle unboxed, bulk videocassettes, 3M has designed the Cassette Hanger to snap in and out of the case hanger bar providing a hook on which to place the videocassette. The Cassette Hanger is made of heavy duty plastic and will fit any case hanger bar, whether it is attached to a shelf, door, wall or mobile cart. Another flexible adaptation of the "Scotch" Hanger System.

**Six-Pack Hanger (6 PH) \$7.41 each**

What else could you call a sturdy, aluminum frame that easily totes up to 6 videocassettes, with the case or without, than the "Six-Pack Hanger"? Simple to carry, lightweight and yet durable, the "Six-Pack Hanger" can be adapted to hold bulk cassettes by adding two Cassette Hangers and two Cassette Hanger Clips on the center bar.

CATALOG NUMBER	RECORDER/PLAYER	UNITS CARTON	REEL SIZE	1-19	20+	100+
360-1-3000-R97B	Ampex 4900, 5000, 6000, 7000	5	1" x 9 1/4"	\$98.82	\$117.12	\$86.32
360-1-2460-R91B	Sony EV-200, EV-300	5	1" x 8"	95.34	109.91	83.28
361-1/2-1200-R148B	Sony, Panasonic, Concord	10	1/2" x 5 1/8"	33.08	30.50	28.89
361-1/2-2400-R153B	EIAJ/STD Recorders	10	1/2" x 7 1/8"	56.12	51.75	49.03
361-1-2150-R139B	IVC 800 (B & H RCA, GPL, Chester)	5	1" x 8"	74.65	68.86	65.22
371-2-2640-R150B	IVC VR 9000	2	2" x 10 1/2"	209.71	160.32	133.36
371-2-4900-R150B		2	2" x 10 1/2"	388.21	314.36	269.20
461-1/2-1200-R148B	Sony, Panasonic, Concord, EIAJ Standard Recorders	10	1/2" x 5 1/8"	33.08	30.51	33.36
461-1-2150-R139B	IVC	5	1" x 8"	73.81	73.61	69.72
461-1-3000-R97B	Sony EV-200/300	5	1" x 9 1/4"	104.82	96.65	91.54
461-1-4300-R159B	Ampex	5	1" x 12 1/2"	185.73	185.95	176.15
461-1-7500-R159B	IVC-900	5	1" x 12 1/2"	304.91	289.67	274.42
479B-1-1630-R172B	Bosch-Fernseh, (BCN), IVC,	5	1" x 9"	101.56	90.63	85.87
479B-1-3170-B172B	Philips, RCA	5	1" x 9"	152.53	136.35	129.17
479B-1-4635-R172B		5	1" x 10 1/2"	230.50	206.01	195.18
479B-1-1630-R174B	Bosch-Fernseh	5	1" x 9"	101.56	90.63	85.87
479B-1-3170-R174B	BCN-20 Portable	5	1" x 9"	152.53	136.35	129.17
479-1-1630-R172B	Ampex VPR-1, 2, Sony	5	1" x 9"	\$101.56	90.63	85.87
479-1-3170-R172B	BVH-1000, Video	5	1" x 9"	152.53	136.35	129.17
479-1-4610-R172B	Memory VM-1000	5	1" x 10 1/2"	230.50	206.01	195.18

CATALOG NUMBER	SIZE	PER CTN.	PRICE CASE LOT	
Empty Metal Video Reels In Box	R91B-1-8 1" x 8"	5	\$27.08	
	R97B-1-9-3/4 1" x 9 3/4"	5	27.08	
	R139B-1-8 1" x 8"	5	27.08	
	R143B-2-8 2" x 8"	2	26.56	Universal Labels
	R143B-2-10-1/2 2" x 10 1/2"	2	31.14	Standard Labels
	R150B-2-10-1/2 CFR 2" x 10 1/2" CFR	2	31.64	
	R159B-1-12-1/2 CFR 1" x 12 1/2" CFR	2	36.23	
	R178-1-9 1" x 9"	5	21.18	
	R178-1-10-1/2 1" x 10 1/2"	5	23.71	
Empty Cardboard Video Boxes	VB-1-10-1/2 1" x 10 1/2"	5	1.97	
	VB-2-10-1/2 2" x 10 1/2"	2	1.97	
Empty (Blue) High Impact Shipping & Storage Containers	C87-1-10-1/2 1" x 10 1/2" NAB	5	14.41	
	*C116-2-10-1/2 1" x 10 1/2" CFR	2	14.41	
	*The C116 shipping case must be used with the Cushion Flange 2" reels (R150).			
Fire Retardant Empty Plastic Shipper/Storage Cases	*C122-1-10-1/2 1" x 10 1/2" for CFR	5	15.54	
	*The C122 shipping case is recommended for use with Cushion Flange 10 1/2" reels such as 479 tape.			
	C129-1-10-1/2 1" x 10 1/2" for non-CFR	5	15.54	
Empty Videocassette Boxes	C-114 Album Box	50	3.00	
	C-120 Mini U-Matic Album Box	70	3.00	
	C-124 Mini-U-Matic Hanger Shipper/Storage Case	60	3.00	
	C-125 Std. U-Matic Hanger Shipper/Storage Case	50	3.00	
	C-127 Beta Hanger Shipper/Storage Case	50	2.50	
	C-128 VHS Hanger Shipper/Storage Case	50	2.50	
	C-130 Beta Album Box	100	2.50	
	C-131 VHS Album Box	100	2.50	
Head Cleaning Videocassettes	UCS-HC (Mini; C-124; recorder)	2	29.00	
	B-HC (VHS; Album box; unrecorded)	10	21.95	
	V-HC (VHS; Album box; unrecorded)	10	22.95	
Empty Plastic 2" Reels In Box	VRB-2-6-1/2 1" x 6 1/2"	12	3.54	
	VRB-1-6-1/2 1" x 6 1/2"	20	3.26	
Empty 1/2" Video Reels In Vinyl Box	R148B-1/2-5-1/8 1/2" x 5 1/8"	10	4.89	
	R153B-1/2-7-1/8 1/2" x 7 1/8"	10	5.09	
Empty Vinyl Video Box	VB-1/2-5-1/8 1/2" x 5 1/8"	10	2.85	
Scotch Hanger System Accessories	CLB-4 (Bar)	25	4.88	
	6-P (VHS)	1	7.41	
	CMH-10 (Plastic Hanger)	50 Bags (500 Units)	2.43	
Empty Vinyl Video Box	VB-1/2-5-1/8 1/2" x 5 1/8"	10	2.85	
Aluminized Splicing Tape - .5 mil	*392-1/4-66 1/4" x 66'	12	4.10	
	*392-1/2-66 1/2" x 66'	12	6.14	
Aluminized Splicing Tape - .25 mil	*393-1/4-66 1/4" x 66'	12	4.10	
	*393-1/2-66 1/2" x 66'	12	6.14	

\*Splicing Tapes Nos. 392 and 393 are recommended for all video splicing requirements and are mandatory for use on all controlled wind video tapes.

Prices and Specifications Subject to Change Without Notice.

# Scotch 3M

## VIDEOCASSETTES



U-MATIC (1/2")  
FORMAT VIDEO  
CASSETTES

MINI-U-MATIC  
FORMAT

MASTER BROADCAST  
U-MATIC FORMAT  
VIDEOCASSETTES

EXTENDED PLAY  
U-MATIC FORMAT

BETA AND VHS (1/2")  
FORMAT VIDEO  
CASSETTES

U-DO-IT (U-MATIC)  
RELOAD KITS

COLOR PLUS  
MINI-U-MATIC  
FORMAT

COLOR PLUS  
MASTER BROADCAST  
U-MATIC FORMAT  
VIDEOCASSETTES

COLOR PLUS  
EXTENDED PLAY  
U-MATIC FORMAT

"Scotch" Brand UCA Videocassettes use a specially designed "cobalt energized" High Energy video tape which provides an excellent signal-to-noise ratio and greater Rf output. The UCA series videocassettes are fully compatible with all 1/2 inch U-matic videocassette systems and the permanent oxide lubrication and time proven backside treatment assure low head wear, extended stop motion and maximum tape life.

"Scotch" Brand Mini-U-matic videocassettes are designed for use with such recorders as the Sony VO-3800 and the JVC CR-4400 portables. An "S" after the playing time (UCA-10S) indicates mini size.

"Scotch" Master Broadcast U-Matic Series (MBU) provides a more rugged, longlife product suitable for repetitive playback and in-clement recording situations such as field (ENG) recording and editing applications. Other features are the same as the Standard Series UCA Videocassettes.

Designated for use where playing time is key factor. This Extended Play U-Matic uses an extra thin polyester backing. Tape machines that are poorly aligned or with incorrect tensioning can cause damage to this product. Performance of this U-Matic on such equipment cannot be guaranteed by the 3M Company.

"Scotch" Brand Beta and VHS Format (1/2") videocassettes both feature a special non-back coated black oxide tape. These cassettes feature improved color, broadband signal-to-noise, improved RF output, low dropouts, very good stop motion capabilities, good runnability with repeat plays and very low head wear. "Scotch" Brand Beta and VHS Formats are compatible with all 1/2" videocassette recorders and playback units. Both Formats have multiple machine switch speed capabilities.

These items permit the field reloading of damaged cassettes. The extra rugged MBU U-matic tape is supplied in the 15S (for Mini) and 30-minute (standard) reload kits. The 60-minute reload kits use UCA U-matic tape.

"Scotch" Brand Mini-U-Matic videocassettes are designed for use with such recorders as the Sony VO-3800 and the JVC CR-4400 portables. Features new COLOR PLUS oxide. An "S" after the playing time (UCA-10S) indicates mini size.

"Scotch" Master Broadcast U-Matic Series (MBU) provides a more rugged, longlife product suitable for repetitive playback and in-clement recording situations such as field (ENG) recording and editing applications. Other features are the same as the Standard Series UCA Videocassettes except MBU cassettes also feature the new COLOR PLUS oxide. All MBU's are packaged in a distinctive tone shell that affords immediate identification, plus one extra safety feature during crucial editing operations.

Designated for use where playing time is key factor. Features new COLOR PLUS oxide. This Extended Play U-Matic uses an extra thin polyester backing. Tape machines that are poorly aligned or with incorrect tensioning can cause damage to this product. Performance of this U-Matic on such equipment cannot be guaranteed by 3M.

ORDER NUMBER	RECORDER/PLAYER	PLAYING TIME	STD CTN	1-19	20-99	100 +
UCA 5 C125 or C114	STANDARD SERIES U-MATICS	15	10	\$24.38	\$22.54	\$21.26
UCA-10 C125 or C114		10	10	25.08	23.19	21.88
UCA-20 C125 or C114		10	10	29.95	27.68	26.11
UCA-30 C125 or C114		10	10	31.03	28.67	27.06
UCA-60 C125 or C114		60	10	41.05	37.86	35.88
COLOR PLUS MINI U-MATICS	UCA-10S C124 or C120 UCA 20S C124 or C120			\$24.66 29.75	\$22.76 27.44	\$21.56 25.99
COLOR PLUS MASTER BROADCAST SERIES U-MATICS	Mini MBU-5S C124 or C120 Mini MBU-18S C124 or C120 Reg MBU-30 C125 or C114 Reg MBU-45 C125 or C114			\$24.66 29.75 34.88 40.06	\$22.76 27.44 32.11 37.04	\$21.56 25.99 30.54 35.28
COLOR PLUS EXTENDED PLAY U-MATICS	UCA 30S C124 or C120 UCA 75 C124 or C120			\$40.06 52.95	\$37.04 48.95	\$35.28 46.62
L-750	BETA FORMAT	120/240/360	20	24.49	17.45	16.62
L-750A		120/240/360	20	25.09	18.05	17.22
L-500 in plastic album box		60/120/180	20	\$18.84	13.41	12.77
L-500A in plastic album box		60/120/180	20	19.44	14.01	13.37
L-250 in plastic album box		30/60/90	20	15.44	10.99	10.47
L-250A in plastic album box		30/60/90	20	16.04	11.59	11.07
T-120 in plastic album box	VHS FORMAT	120/240/360	20	\$28.55	19.60	18.15
T-120A in plastic album box		120/240/360	20	29.15	20.20	18.75
T-60 in plastic album box		60/120/180	20	22.31	15.31	14.17
T-60A in plastic album box		60/120/180	20	22.91	15.91	14.77
T-30 in plastic album box		30/60/90	20	19.58	13.45	12.45
T-30A in plastic album box		30/60/90	20	20.18	14.05	13.05
U-DO-IT 18S (MBU TAPE)	RELOAD KITS		10	\$20.09	\$18.87	\$17.72
U-DO-IT 30 (MBU TAPE)			10	23.60	22.42	21.23
U-DO-IT 60 (UCA TAPE)			10	30.34	28.82	27.31

NOTES:

- If full-size 1/2" U-matic Videocassettes are to be delivered in the book shelf pack container, insert C114 at the end of the catalog number, i.e., UCA-60C114. If they are to be delivered in the high impact plastic shipping container, insert C125 at the end of the catalog number, i.e., UCA-60C125. THERE IS NO ADD-ON CHARGE FOR EITHER CONTAINER.
- If 1/4" Mini-U-matic Videocassettes are to be delivered in the book shelf pack container, insert C120 at the end of the catalog number, i.e., UCA-20SC120. If they are to be delivered in the high impact plastic shipping container, insert C124 at the end of the catalog number, i.e., UCA-20SC124. THERE IS NO ADD-ON CHARGE FOR EITHER CONTAINER.

# Scotch 3M

## AUDIO OPEN REEL TAPE

AV LINE: The AV Line are Low Noise, heavy duty, open reel tapes designed for the rigorous use of instructional applications.

PROPACK	CATALOG NUMBER	REEL SIZE	REELS PER CTN.	SHPG. WT. (LBS.)	LIST
AV LINE —	176-1/4-800	5"	12	4.3	\$4.90
PROPACK	176-1/4-1200	7"	12	9	7.46
176, 177	177-1/4-900	5"	12	4.5	6.12
178, 179	177-1/4-1800	7"	12	9	10.18
	178-1/4-1200	5"	12	4.4	12.16
	178-1/4-2400	7"	12	10	16.06
	179-1/4-1800	5"	12	4.6	14.86
	179-1/4-3600	7"	12	10	19.60
SPECIAL PACKAGES	176-1/4-2500-H	HUB	12	10.7	15.42
176, 177	176-1/4-2500-RN	10-1/2"	12	22.9	21.18
178	176-1/4-2500-RPS	10-1/2"	12	21.5	21.18
	177-1/4-3600-H	HUB	12	17.8	22.36
	177-1/4-3600-RN	10-1/2"	12	23.5	28.10
	177-1/4-3600-RPS	10-1/2"	12	21.5	28.10
	178-1/4-4800-RPS	10-1/2"	12	21	46.26

Nos. 206 and 207 are High Output/Low Noise open reel tapes designed for critical music mastering. Nos. 208 and 209 are Print/Low Noise open reel tapes designed for critical voice and general music mastering. No. 250 is a premium quality tape for critical studio mastering.

PROPACK	CATALOG NUMBER	REEL SIZE	REELS PER CTN.	SHPG. WT. (LBS.)	LIST
206, 207	206-1/4-1200	7"	12	9.7	10.14
	206-1/4-2500-H	HUB	12	19.6	18.34
	206-1/4-2500-RN	10-1/2"	12	25.2	24.90
	207-1/4-1700	7"	12	10.4	13.38
	207-1/4-3600-H	HUB	12	22	28.24
	207-1/4-3600-RN	10-1/2"	12	26.3	35.12
PROPACK	208-1/4-600	5"	12	4.5	3.30
208, 209	208-1/4-1200	7"	12	9.5	11.14
	208-1/4-2500-H	HUB	12	17.8	19.34
	208-1/4-2500-RN	10-1/2"	12	24	24.34
	209-1/4-900	5"	12	4.7	6.28
	209-1/4-1800	7"	12	9.8	13.58
	209-1/4-3600-H	HUB	12	19.7	28.24
	209-1/4-3600-RN	10-1/2"	12	25	35.12
PROPACK	250-1/4-1200	7"	12	10.4	11.76
250	250-1/4-2500-H	HUB	12	20	23.66
LUBE TAPE	250-1/4-2500-RN	10-1/2"	12	26	31.24
158	158-1/4-1800	7"	12	9.5	9.52
LUBE TAPE	A special lubricated tape for endless loop applications in various types of machines.				

## AUDIO TAPE ACCESSORIES

	CATALOG NUMBER	SIZE	PER CTN.	RETAIL
No. 41	41-1/2-12.5	1/2" x 66'	40	\$1.09
Splicing Tape	41-7/32-66	7/32" x 66'	40	3.09
	41-1/2-66	1/2" x 66'	40	2.09
	41-3/4-66	3/4" x 66'	40	2.21
No. 41-1/2-12.5 is packaged on a core in a plastic bag, without a dispenser. Bag is die-cut for pegboarding. Color: White, Backing: 1.5 mil Acetate				
No. 67	67-7/32-100		12	4.37
Splicing Tape	67-1/2-100		12	5.64
	67-1-100		12	8.42
No. 67 is a professional studio grade splicing tape. Color: White, Backing: 1.0 mil Acetate				
No. 620 Splicing Tape may be used to splice all "Scotch" Brand Recording Tapes. Always use No. 620 when splicing tapes with "POSI-TRAK" backing. Color: White, Backing: 1.0 mil Polyester				
No. 620	620-7/32-66	7/32" x 66'	12	4.49
Splicing Tape	620-1/2-66	1/2" x 66'	12	6.19
SK Splicing Tape	SK-7/32-12.5		48	2.29
SK Splicing Kit includes a splicing block and 12.5 feet of polyester Splicing Tape on dispenser. Kit is carded for pegboarding.				
No. 51	51	7/32" x 150"	12	1.99
Aluminized Sensing Tape	SC-HC		20	1.79
SC-HC Head Cleaner Cassette				
No. 20	20-1/4-1000	1/4" x 1000'	12	2.72
Leader Tape, Paper				
No. 61 Leader and Timing Tape, Plastic	61W-1/4-100	White 100'	100 (10)	2.19
	61Y-1/4-100	Yellow 100'	100 (10)	2.19
	61V-1/4-1500	White 1500'	20	4.01
When ordering specify correct catalog number for color desired.				
Empty Plastic or Metal Reel in Paper Box	RB-1/4-5	5"	12	1.29
	RB-1/4-7	7"	12	1.89
	RNB-1/4-10-2M	10-1/2"	12	11.99
	RB-1/4-7	7"	12	5.89
	RB-1/4-10-2 RPS	10-1/2"	12	6.98
Empty Paper Boxes	B-1/4-5	5"	48	.79
	B-1/4-7	7"	48	.99
	B-1/4-10-1/2	10-1/2"	12	1.99
Pre Cut Splicing Tabs	PT-7/32-36	7/32" x 3/4"	400 (20)	1.39
Aluminized Sensing Tabs	SST-7/32-18	7/32" x 3/4"	400 (20)	1.39
Cassette Edit and Repair Kit	ERK-130 Carded		20	3.39



### STUDIO MASTER CASSETTES

Studio Master Cassettes have been designed for optimum performance at normal tape selector switch positions. It is a High Output product for critical mastering and duplicating applications.

CATALOG NUMBER	PER CTN.	PER CASSETTE			
		1-79	80+	600+	1200+
AVM-30	40	\$3.00	\$2.22	\$2.10	\$2.00
AVM-60	40	3.41	2.56	2.42	2.31
AVM-90	40	3.73	3.11	2.95	2.81

Studio Master Cassettes have been designed for optimum performance at normal tape selector switch positions. It is a High Output product for critical and duplicating applications.

### AV CASSETTES

AV cassettes are professional quality low noise cassettes designed for the rigorous use of instructional applications.

CATALOG NUMBER	PER CTN.	PER CASSETTE			
		1-159	160	960	1920
AVC-60 FILE	160	\$2.22	\$1.61	\$1.53	\$1.45
AVC-90 FILE	160	3.11	2.24	2.17	2.11
Standard Pack:		1-79	80+	600+	1200+
AVC-20 Std. Pack	40	\$1.71	\$1.26	\$1.24	\$1.15
AVC-30 Std. Pack	40	1.82	1.32	1.23	1.18
AVC-45 Std. Pack	40	2.13	1.54	1.49	1.38
AVC-60 Std. Pack	40	2.22	1.61	1.53	1.45
AVC-90 Std. Pack	40	3.11	2.24	2.17	2.11
AVC-120 Std. Pack	40	4.65	3.39	3.24	3.20

AV File System Cassette Packaging: A complete AVC File System Unit (Master Carton) consists of 96 cassettes of identical length, packed 24 cassettes to an individual drawer, with four drawers packed in the storage cabinet. Each drawer contains index write-on labels and a catalog sheet. Each AV cassette is individually packed in a clear, one-piece plastic sleeve.

A Standard Pack consists of 40 cassettes of identical length per carton; each cassette is individually packaged in a clear plastic sleeve.

### IR CASSETTES

Instant Record Cassettes are leaderless, professional quality, Low Noise cassettes designed for instant recording applications such as dictating, interviewing, conference recording, slide sync, surveillance, and information logging.

CATALOG NUMBER	PER CTN.	PER CASSETTE		
		1-99	100+	240+
IRC-30 BOXED	20	\$1.91	\$1.56	\$1.39
IRC-60 BOXED	20	2.34	1.87	1.66
IRC-90 BOXED	20	3.21	2.55	2.27

### MINICASSETTES

RD-30 is a pre-loaded Minicassette designed for use with Norelco-style Minicassette recorders. Minicassette provides a total of 30 minutes recording (15 minutes each side). \*Two (2) RD-30 Minicassettes per card.

RD-30* Carded	10	\$9.19	\$8.79	\$6.59
---------------	----	--------	--------	--------

### BULK CASSETTES: MBC CASSETTES

Bulk version of Studio Master Cassettes. Identical performance, but bulk packaged without labels.

CATALOG NUMBER	1-399	400+	1200+	
MBC-20	400	\$2.34	\$1.72	\$1.56
MBC-30	400	2.63	1.86	1.71
MBC-45	400	2.89	2.05	1.84
MBC-60	400	2.98	2.16	2.00
MBC-90	400	3.24	2.64	2.45
MBC-120	400	5.34	3.88	3.64

Designed especially for critical mastering applications. Bulk version of our Studio Master Cassettes. Packed 25 identical cassettes per overwrapped intermediate tray and 250 identical cassettes per master carton. Black high impact styrene plastic shells are used. Scotch assembly.

Low Noise Oxides-Backside treated polyester for long clean running life. Each cassette has the playing time stamped in colored ink on its front edge. Acetal resin roller guides, wear shims, metal spring pressure pad.

### SBC CASSETTES

Bulk version of AV Cassettes. Identical performance, but bulk packaged without labels.

CATALOG NUMBER	1-399	400+	1200+	
SBC-10	400	\$1.52	\$1.27	\$1.01
SBC-20	400	1.74	1.23	1.13
SBC-30	400	1.80	1.27	1.15
SBC-45	400	2.07	1.47	1.34
SBC-60	400	2.16	1.53	1.44
SBC-90	400	2.97	2.11	2.03
SBC-120	400	4.52	3.38	3.08

Designed for highest quality reproduction and capable of high speed duplication. Bulk Version of our AV Cassettes.

Packed 25 identical cassettes per overwrapped intermediate tray and 250 identical cassettes per master carton. Smoke-amber high impact styrene plastic shells are used.

Clear P.E. leader at each end of tape.  
Low Noise Oxides-Backside treated polyester for long clean running life.  
Silent metal corner guides.

Each cassette has the playing time stamped in colored ink on its front edge.  
10, 20 and 30 minute lengths. 1 mil rugged Polyester backings for greatest reliability.

### IRC BULK CASSETTES

Bulk version of IR Cassettes. Identical performance, but bulk packaged without labels.

CATALOG NUMBER	1-399	400+	(PER CASSETTE) 1200+	
IRC-30 BULK	400	\$1.80	\$1.27	\$1.15
IRC-60 BULK	400	2.16	1.55	1.44
IRC-90 BULK	400	2.97	2.11	2.03

Same features as the SBC series but in (b.) the clear leader is replaced by rugged 1.5 mil P.E. based low noise magnetic tape which permits no waiting to record and is suitable for use in dictation, phone answering, music, conference, interviewing and surveillance recordings.

NOTE: One piece clear plastic storage sleeves are available at \$.15 each, packed 250/carton.



# Scientific Atlanta

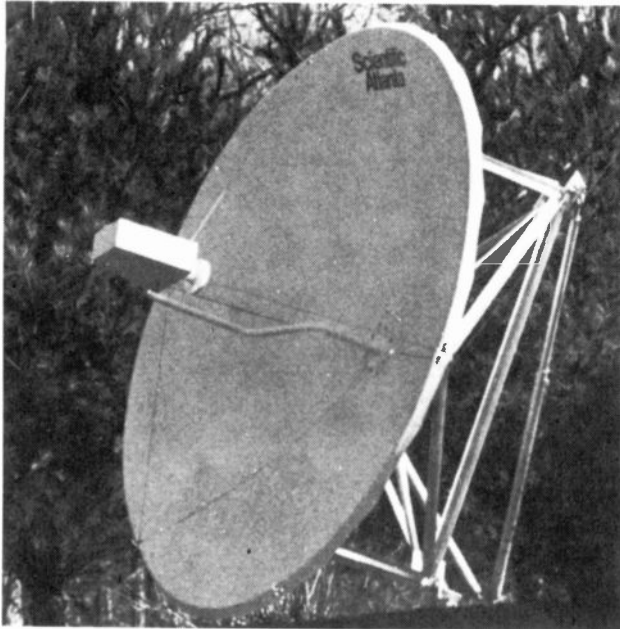

8006

## 3-METER EARTH STATION, MODEL 8006

### Features

- Minimum shipping costs
- Minimum site preparation and installation costs
- No panel alignment or testing required at installation
- Single-axis mount for ease of pointing
- Rigid mechanical design
- Single or dual-polarized feed system
- Modular, interchangeable parts for ease of field support
- Stamped aluminum panels for consistently good surface accuracy

The Scientific-Atlanta 3-Meter Earth Station Antenna offers excellent performance and maximum cost effectiveness for audio digital and video receive-only applications. It was developed out of the design and manufacturing technology that produced the highly successful 4.6-meter and 5-meter Scientific-Atlanta antennas.

Manufactured with precision die-stamping techniques pioneered by Scientific-Atlanta, the 3-meter antenna has six reflector panels. No special tools, panel alignment or testing are required to achieve the specified performance. Compact components allow economical transportation and facilitate assembly in remote sites or on rooftops where handling equipment is not readily available.

The single-axis mount provides pointing accuracy, structural safety, and simple pointing adjustment. With proper alignment on installation, the antenna can be pointed with a single-axis adjustment to any two satellites in the 90-136° arc with zero pointing error. Similar pointing adjustments can be made in the 70-90° arc by a single strut change.

For minimum installed cost, a specially designed foundation kit, which reduces both concrete requirements and installation time, is available.

Model 8006 3-Meter, Dual Polarization, Dual Reflector Feed antenna with:

- anchor bolt mount
- 1.5 dB noise figure GaAs FET preamplifier
- 100 ft., 7/8 in. coaxial cable and connectors
- Automatic cable and feed pressurization/dehydrator system
- Model 6601 Video Receiver, fixed frequency, including jumper cables

**8,750.00**

200

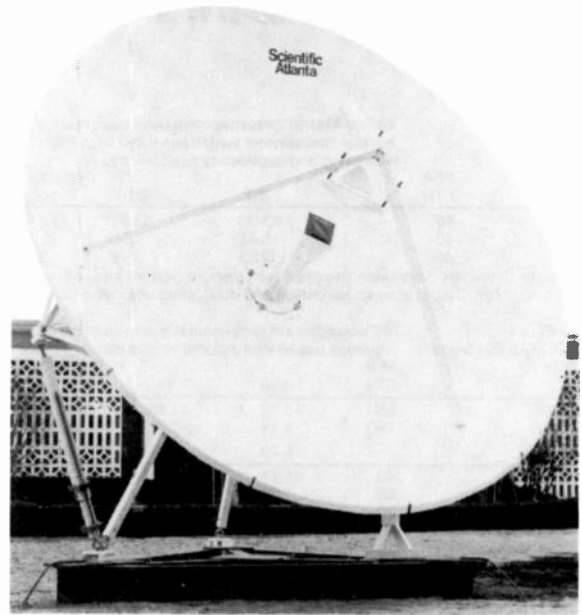

8005

## 4.6-METER ANTENNA, MODEL 8005

### Features

- Cassegrain Feed for High-Efficiency RF Performance
- Protected Environment Behind Reflector for LNA's
- Designed for Minimum Maintenance
- Stamped Aluminum Reflector Panels Provide Consistent Surface Accuracy
- Designed for Minimum Shipping and Installation Costs
- No Panel Alignment or Testing Required
- All-Aluminum Reflector for Maximum Temperature Stability
- Minimum Site Preparation Required
- Field-Erectable Without Crane

For receive-only applications in the 3.7- to 4.2-GHz range, the Scientific-Atlanta Model 8005 4.6-Meter Earth Station Antenna System can easily be installed in a wide variety of locations with a minimum of site preparation. This antenna system is especially suited to the needs of the CATV operator receiving video programming from domestic satellites.

Two men can easily install this antenna in less than one day, as no special tools are required and no part weighs more than 45 kg (100 lb).

The main reflector is parabolic in shape. A specially shaped subreflector focuses the incoming signal into the feed horn. The optics used provide high gain while still meeting FCC sidelobe requirements. The parabolic dish consists of 12 aluminum panels and a sturdy support structure to create a stable reflective surface. Panels are manufactured utilizing a die-stamping production technique that ensures consistency in the reflector-panel repeatability. This factory-produced accuracy guarantees complete interchangeability and simplified construction efforts in the field. The concept of modularity provides benefits in handling ease, lower shipping costs, and ease of installation.

The standard feed system furnished for receive-only operation provides dual-polarization capability in the 3.7- to 4.2-GHz range. The feed includes a high-efficiency diagonal horn that can be manually rotated to any position. Receive/transmit operation can also be provided with a special feed. Please contact Midwest for further information.

Model 8005 4.6 Meter, Dual Polarization, Dual Reflector Feed antenna with:

- anchor bolt mount
- 1.5 dB noise figure GaAs FET preamplifier
- 100 ft., 7/8 in. coaxial cable and connectors
- Automatic cable and feed pressurization/dehydrator system
- Model 6601 Video Receiver, fixed frequency, including jumper cables

**\$11,625.00**

Prices and Specifications Subject to Change Without Notice.

# Scientific Atlanta

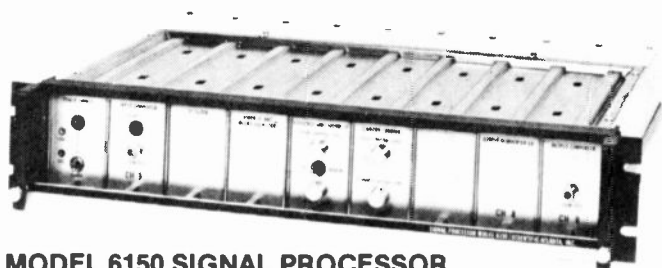

## MODEL 6150 SIGNAL PROCESSOR

The 6150 Signal Processor is totally solid state. Each circuit module is completely enclosed and is accessible from the front panel of the unit which occupies only 3½ inches of vertical rack space. The modules of the processor consist of the power supply, input converter, IF filter, video IF, and delay equalizer, video AGC and sound IF, standby carrier, output converter local oscillator, and the output converter. For the phase lock option, the output converter local oscillator and a blank module are replaced with the phase lock output converter local oscillator and the phase lock servo module.

Through the use of double balanced mixers and hybrids circuits spurious outputs are virtually eliminated from 5 MHz to 300 MHz.

Adjacent channel rejection is reduced to 60 dB minimum through the use of double-notches at each of the nearest adjacent channel carriers (upper adjacent channel picture carrier, lower adjacent sound carrier, and lower adjacent color sub-carrier).

Envelope delay is held to a minimum through the use of an all-pass phase equalizer located in the video IF amplifier.

The standby carrier oscillator has several modes of operation including CW, internally modulated with a 15 kHz keying pulse, and an external mode. This external mode greatly facilitates emergency audio and/or video override for community alert requirements. It also allows the operator to utilize his headend as a source of modulated signals with which to measure the cross-modulation in the distribution system.

Output frequencies from sublow through superband are standard. A plug-in UHF to IF input converter is also standard eliminating the need for separate UHF/VHF converters in many instances. Tunable input and output converters for standby applications are also available.



## MODEL 6250 TELEVISION DEMODULATOR

The Model 6250 Television Demodulator provides precision demodulation of any transmitted television signal. The envelope delay provided closely matches that of the average home television receiver. This permits use with transmitters which have been predistorted to compensate for this delay. An integral zero chopper enables measuring the depth of modulation of the transmitted signal. In addition, a programming option allows external command of the zero chopper.

The demodulator is equipped with an envelope detector for the video, and may be ordered with an optional synchronous detector. The synchronous video detector is free from quadrature distortion that is found in all vestigial sideband envelope detectors. Quadrature distortion is a source of unsymmetrical ringing and smear and cross talk between video sideband components.

Audio is provided both as a baseband signal and as a 4.5 MHz subcarrier. A loop-through is provided to permit the addition of the aural subcarrier to one of the video outputs for transmission of the sound signal at a frequency above the spectrum occupied by the video signal in microwave installations.

## OPTIONS

- Synchronous video detector is free of quadrature distortion that is found in all vestigial sideband envelope detectors. With the synchronous detector, capability is provided on the front panel to rapidly switch between envelope and synchronous detectors, greatly enhancing the diagnostic and operational capabilities of the demodulator. If the synchronous detector is supplied, two options are available in the sound detector. The source for the 4.5 MHz aural subcarrier can be switched between either a direct mixer, using the phase-lock synchronous oscillator and audio IF signal, or an intercarrier detector using composite video and sound IF signals.
- 50 ohm input impedance.
- Standby Battery Powering provides backup for failure of 115V ac.
- Negative dc powering permits operation from a -19 to -31V dc battery supply in lieu of 115V ac.

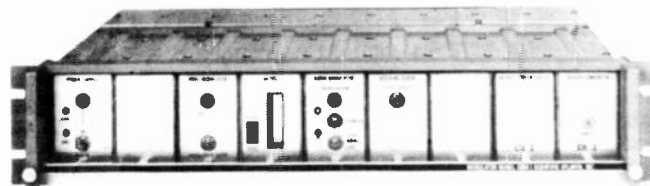

## MODEL 6350 TELEVISION MODULATOR

The Model 6350 Television Modulator generates a high quality vestigial sideband TV signal on all cable TV channels. Advanced circuit design results in the highest picture and sound fidelity from color or black and white video inputs and from either audio or 4.5 MHz subcarrier inputs. Scientific-Atlanta's pioneering application of the SAW\* filter to CATV equipment results in unequalled vestigial sideband response characteristics. The SAW filter provides superior adjacent channel performance while retaining excellent group delay characteristics. Use of the SAW filter virtually eliminates vestigial sideband filter adjustments and provides excellent temperature stability.

A delay predistortion network is provided to conform with the standard FCC predistortion requirements. Front and rear panel test points are provided to assist in module troubleshooting. Also provided are rear panel connectors for alternate IF inputs and outputs to facilitate program switching.

The Modulator provides a fixed level, composite IF output, which can be used without external splitters.

\*Surface Acoustical Wave

## OPTIONS

- The video switch detects loss of primary video and switches to alternate video input.
- Video AGC normalizes video level between different video sources such as two video tape recorders, or removes time dependent level changes from incoming video.
- Audio Switch option provides for selection of an alternate audio source, and also permits switching to emergency override audio.
- Audio Modulation Limiter prevents accidental overdeviation of the aural carrier.
- IF Switch provides switching to an alternate IF source when video input is removed.
- AGC control on alternate IF input provides for a constant output level when the alternate IF is being used.
- Phase Lock of the output picture carrier is available.
- Standby Battery Powering provides backup for failure 115V ac.
- Negative dc powering permits operations from a -19 to -31V dc battery supply in lieu of 115V ac.

# Scientific Atlanta

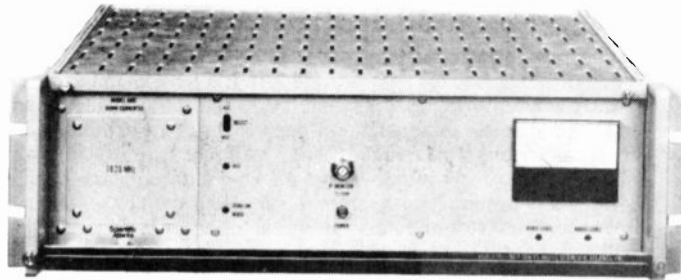

## VIDEO RECEIVER MODEL 6601

The Model 6601 Frequency Selectable Receiver provides high-quality picture and sound reception of domestic satellite television transmissions.

Modular and compact, the complete receiver is packaged in a single chassis 133.4mm (5.25 in.) high by 482.6mm (19.0 in.) wide to permit standard racking. A motherboard is utilized to interconnect the vertically mounted plug-in printed circuit cards. A ground plane and partitions between each card provide isolation.

Threshold extension demodulation, a technique pioneered by Scientific-Atlanta, significantly increases operating margin above threshold. Operating as a standard discriminator over the range of normal carrier-to-noise (C/N) ratios, it automatically switches to extend the operating range at lower C/N ratios. Impulse noise in the video signal is reduced near the threshold level and acceptable picture quality is extended to considerably lower operating signal levels than with conventional demodulation.

### FEATURES

- Threshold extension demodulation provides enhanced picture quality at lower signal levels for reduced system cost.
- Solid-state reliability.
- Easy-access plug-in downconverter.
- Plug-in cards allow simplified field service.
- Adaptable for microwave applications.
- Optional audio demodulators for future audio services.
- Channel selection is accomplished by changing crystals. No tuning necessary.

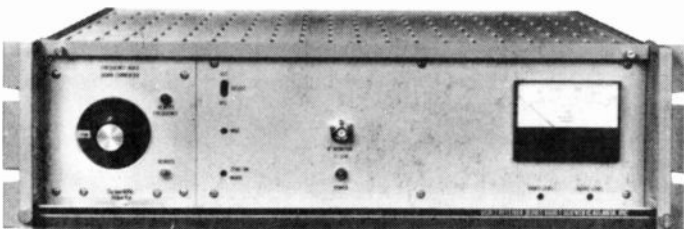

## VIDEO RECEIVER MODEL 6602

The Model 6602 Video Frequency Agile Receiver lets you dial any of 24 satellite channels simply by turning a single selector switch on the front panel. Or for remote operation, it is 6-channel programmable with activation by touch tone or any compatible timing mechanism.

The modular design of the 6602 gives it the versatility to receive any type of video satellite transmission today. It contains provisions to accept optional plug-in subcarrier printed circuit cards for a variety of system applications and microwave interface.

For high quality voice and picture reception, dual conversion and Threshold Extension Demodulation (TED) are standard features. TED significantly increases receiver operating range at low signal levels. Impulse noise in the video signal is reduced near the threshold level and high picture quality is extended to considerably lower operating signal levels than with conventional demodulation.

### FEATURES

- Frequency agility provides selection of any one of 24 channels with one receiver.
- Internally programmable for single line selection of one of any six frequencies. Remote code access to any one of 24 transponder frequencies when interfaced with Scientific-Atlanta 1:N video protection switch.
- Threshold extension demodulation provides enhanced picture quality at lower signal levels for reduced system cost.
- Easy-access plug-in down converter.
- Plug-in cards allow simplified field service.
- Adaptable for microwave applications.
- Optional audio demodulators for future audio services.
- Solid-state reliability.

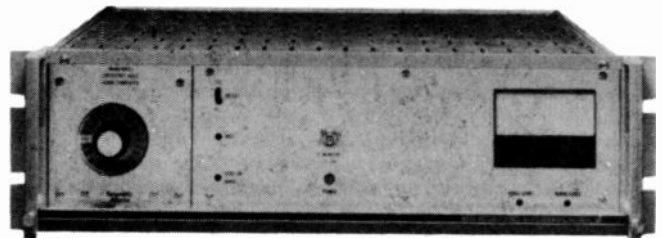

## VIDEO RECEIVER MODEL 6603

The Model 6603 Video Frequency Agile Receiver lets you dial any of 24 satellite channels simply by turning a single selector switch on the front panel. The modular design of the 6603 gives it the versatility to receive any type of video satellite transmission today. It contains provisions to accept optional plug-in subcarrier printed circuit cards for a variety of system applications and microwave interface.

For high quality voice and picture reception, dual conversion and Threshold Extension Demodulation (TED) are standard features. TED significantly increases video signal-to-noise ratio while operating with lower input carrier-to-noise ratios.

### FEATURES

- Frequency agility provides selection of any one of 24 channels with one receiver.
- Threshold extension demodulation provides enhanced picture quality at lower signal levels for reduced system cost.
- Easy-access plug-in downconverter.
- Plug-in cards allow simplified field service.
- Adaptable for microwave applications.
- Optional audio demodulators for future audio services.
- Solid-state reliability.



FROM SHARP MINDS  
COME SHARP PRODUCTS

## XC-700 PROFESSIONAL PRISM OPTICS COLOR CAMERA

- 2 Line Enhancement
- 550 Lines Resolution
- Prism Beam Splitter
- Broadcast I & Q Encoder
- Rugged Die-Cast Chassis
- 2 Line Image Enhancement with Comb Filtering
- Dynamic Beam Optimization
- SATICON\* Tubes with Bias Light
- Adjustable Blanking width — H & V
- Gen-Lock with H and SC phase Shifters
- Phantom Power for Condenser Microphones
- Zebra Pattern Video Level Indicator for Viewfinder

### ENG-PORTABLE SYSTEM

#### XC-700MP

Includes:

XC-700M	Camera Head with Quick Disconnect Tripod Mount, Battery Bracket, Service Manual, Extender Board, Spare Fuses	
XC-715VF	1.5" Viewfinder	
XC-712AA	A.C. Power Adaptor with DC Cable	
XC-70BAT	14.4V 4AH Heavy Duty Ni-Cad Rechargeable Battery	
XC-70SC	Slow Battery Charger for XC-70BAT	
XC-70CC	Heavy Duty Carrying Case	\$11,000.00

Less Lens — Less VTR Cable

### EFP-STUDIO SYSTEM

#### XC-700MS

Includes:

XC-700M	Camera Head with Quick Disconnect Tripod Mount, Battery Bracket, Service Manual, Extender Board, Spare Fuses	
XC-770VF	7" Studio Viewfinder	
XC-701RP	Remote Operations Panel (19" Rack Mount)	
XC-712AA	A.C. Power Adaptor with DC Cable	\$11,800.00

Less Lens — Less Camera Cable

### ENG—EFP PORTABLE AND STUDIO SYSTEM COMBINATION PACKAGE

#### XC-700MC

Includes:

XC-700M	Camera Head with Quick Disconnect Tripod Mount, Battery Bracket, Service Manual, Extender Board, Spare Fuses	
XC-715VF	1.5" Viewfinder	
XC-770VF	7" Studio Viewfinder	
XC-701RP	Remote Operations Panel (19" Rack Mount)	
XC-70BAT	14.4V 4AH Heavy Duty Ni-Cad Rechargeable Battery	
XC-712AA	A.C. Power Adaptor with DC Cable	
XC-70SC	Slow Battery Charger	
XC-70CC	Heavy Duty Carrying Case	\$13,490.00

Less Lens — Less Camera Cable — Less VTR Cable

### CAMERA HEAD ONLY

XC-700M	Camera Head with Quick Disconnect Tripod Mount, Battery Bracket, Service Manual, Extender Board, Spare Fuses	\$9170.00
---------	--	-----------

### CAMERA HEAD AND COMPONENTS

XC-700M	Camera Head with Quick Disconnect Tripod Mount, Battery Bracket, Service Manual, Extender Board, Spare Fuses	\$9,170.00
XC-715VF	1.5" Viewfinder with Zebra Pattern and Peaking	715.00
XC-770VF	7" Studio Viewfinder with Zebra Pattern, Underscan and Peaking	860.00
XC-701RP	Remote Operations Panel	1630.00

## PROFESSIONAL COLOR CAMERA



XC-700M

### ACCESSORIES

XC712AA	A.C. Power Adaptor with DC Cable	\$140.00
XC-70BAT	14.4V 4AH Heavy Duty Ni-Cad Rechargeable Battery	565.00
XC-70SC	Slow Battery Charger for XC-70BAT	70.00
XC-70QC	Quick Charger for XC-70BAT	375.00
XC-3B7VB	Heavy Duty VTR Cable with 14 Pin Connector — Recommended for Broadcast ENG Use	285.00
XC-3B7V	VTR Cable with 14 Pin Connector — Recommended for Light Duty Use Only	145.00
XC-3B7VA	VTR Cable with 10 Pin Connector	145.00
XC-70CC	Heavy Duty Carrying Case	340.00
XC-70QRP	Tripod Quick Release Plate — Heavy Duty	130.00
XC700KIT-0001	Spare Parts Kit (available through Parts Dept.)	1995.00
XC-702HE	2-Line Enhancement Board — for Retrofitting Cameras with 1-Line Board	1400.00

#### Standard Cables

XC-7B20	Camera Cable — 20 Meter (65 feet)	760.00
XC-7B30	Camera Cable — 30 Meter (98 feet)	1000.00
XC-7B50	Camera Cable — 50 Meter (164 feet)	1480.00

#### Custom Cables

Available from 5 Meter to 100 Meter Lengths in 5 Meter Increments. Allow at least 3 weeks for delivery  
No changes or cancellations accepted after order is placed.

XC-7B	Camera Cable — Meter	\$24/Meter +280.00
XC-7B E	Camera Extension Cable — Meter	\$24/Meter +280.00

#### Example:

XC-7B60	Camera Cable — 60 Meter (197 feet)	1,720.00
---------	------------------------------------	----------

#### Industrial Grade Lenses

A10X11B	Fujinon 11-110mm f1.6 zoom lens with servo zoom and servo iris	\$1429.00
A14X10B	Fujinon 10-140mm f1.7 zoom lens with servo zoom and servo iris	2500.00

#### Broadcast Grade Lenses

A12X9B	Fujinon 9-108mm f1.7 zoom lens with servo zoom and servo iris	4740.00
A12X9BE	Fujinon 9-108mm f1.7 zoom lens with servo zoom, servo iris and 2.2X extender	5300.00
J13X9BE	Canon 9-117 f1.6 zoom lens with servo zoom, servo iris and 2X extender	6000.00
A14X9BE	Fujinon 9.5-133mm f1.7 zoom lens with servo zoom, servo iris and 2X extender	7370.00
A17X9BE	9-153mm f1.7 zoom lens with servo zoom, servo iris and 2X extender	10,610.00
A22X12E	12.5-275mm f2 zoom lens with servo zoom, servo iris and 2X extender	13,750.00

#### Studio Conversion Kits (provides servo zoom and manual focus from rear)

XC-70SC1	Studio Conversion Kit for A10X11B or A14X10B Lens	850.00
XC-70SC2	Studio Conversion Kit for A12X9B, A12X9BE, or A14X9BE Lens	850.00
XC-70SC3	Studio Conversion Kit for A17X9BE Lens	850.00
XC-70SC4	Studio Conversion Kit for A22X12E Lens	850.00
XC-70SC5	Studio Conversion Kit for J13X9E Lens	1485.00

Prices and Specifications Subject to Change Without Notice.

# SHINTRON

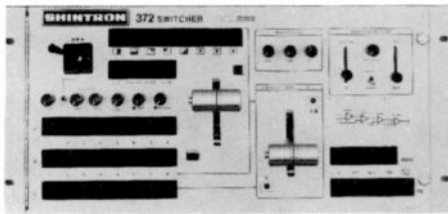

372

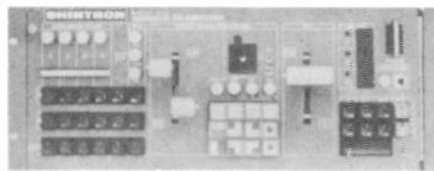

373-DX

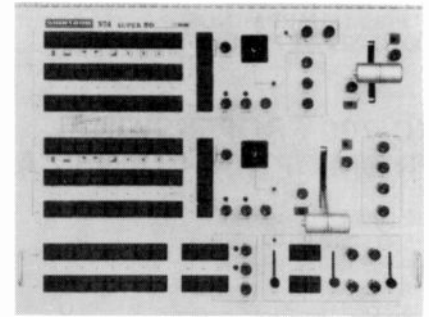

374

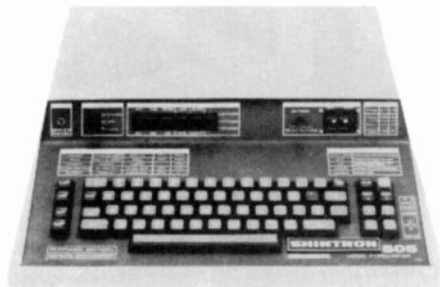

505

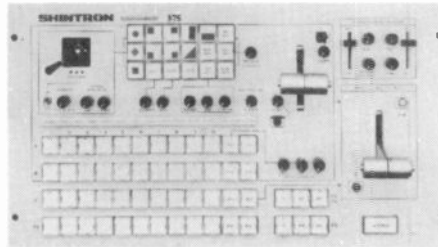

375

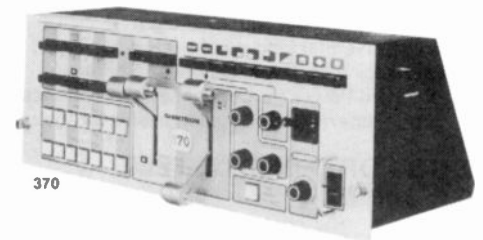

370

## VIDEO SWITCHERS SPECIAL EFFECTS

### Model 373—DX Chromatic® Production Switcher NTSC Version

Model 373 Chromatic® Production Switcher has been exclusively designed to interface with Sony color cameras and accessories. It eliminates requirements for a Sync generator and the Model 373 is plug compatible with DXC-1000, DXC-1600 cameras

The 373-DX is the basis for an entire high performance studio. The unit has a broadcast grade, color bar generator, a color black generator, a color background generator, 10 wipe patterns, soft wipe, border wipe, and INT-EXT key.

The Model 373 Switcher is equipped with a unique tally indicator. The digital display indicates which inputs are selected and which are "on-air"

- 373-DX (Sony Connectors) ..... \$7510.00
- 373-NU (BNC Connectors) ..... 7510.00

### Model 370—Mark III Color Special Effects Generator

• 10 Basic Wipe Patterns • Universal Input System • Vertical Interval Switching on Preview and Program Busses • Built-in Keyer and Colorizer • More than 1000 Units Have Been Made

Model 370 Mark III Color Special Effects Generator. Complete color studio programming switcher has features of most modern professional studio equipment together with compact size and human engineered operation panel for teleproduction directors. NTSC. Universal input system (color or mono, comp or noncomp, sync or non-sync). Six inputs. Vertical interval switching on preview and program busses. Automatic take from preview to program. Re-entry system. Ten basic wipe patterns: four corners, fade, wipe, diagonal, joystick control of circle, square and diamond. Keying and matting. Built-in colorizer, background generator, and color black generator. Built-in tally contacts. Geareduction Lever. Rack height 7" ..... \$2600.00

- 370/318 As Above with Genlock Sync Generator ..... 3800.00

### Model 372—Switcher

The Model 372 Switcher is equipped with 8 inputs and 3 buses and is primarily designed as a workhorse for small studios or mobile van uses. It can be configured either in one enclosure or two enclosures for remote control.

In the past all production switchers have been designed with three major components. The cross point group, the effects amplifiers, and the downstream cross point group. The video signal, therefore traveled through this complex maze of amplifiers. The path was different every time a different effect was desired.

In addition, conventional switchers were full of delay lines in order to compensate for the delay caused by amplifiers. As a result, the video signal deteriorated through the switcher. Obviously, substantial efforts in circuit design were spent to compensate for the signal deterioration, and this made switchers generally expensive to manufacture.

Shintron's approach solves this problem altogether. After the cross point group, selected signals are processed through one precision summing amplifier. The summing amplifier has multiple input capability and each input circuit is equipped with a digitally controlled high-speed linear switch element.

The summing amplifier is an extremely precise short-electrical length design and has a near zero differential phase and gain. An important fact is that all combinations of effects are processed through the identical path, and the resultant electrical delay through the switcher is also identical. .... \$6500.00

### Model 374—Super 80 Switcher

The Model 374 Super 80 is a sophisticated switcher due to its double special effects busses capable of making double re-entry operations. The Super 80 Switcher is unprecedented in having standard encoded chroma keyer, downstream matte keyer, downstream fade to black and quadsplitter. The unit is intended for use as a main switcher in advanced production situations, studio or mobile.

No electrical specifications were compromised in the place of having spectacular features. Electrical and mechanical specifications are of broadcast quality.

In addition, the 374 was designed with a precision summing amplifier to eliminate the delay problems and signal deterioration inherent to conventional switchers. .... \$9900.00

### Model 375—Chromatic™ SuperSwitcher Production Switcher

The Model 375 is designed for medium to large teleproduction applications and is equipped with the most up-to-date technology in switcher design, Superbus. Unlike conventional switcher design which passes video signals through a series of cascading effects amplifiers to obtain the desired effects, Superbus achieves it all at once. The Superbus is a combination of a super group of cross points and effects amplifiers totally controlled by digital signal processing commands. Since this new method has practically no signal path length, the resultant signal does not deteriorate like in a conventional switcher. Its differential gain and phase are near zero, and delay is almost non-existent.

The Model 375 is a 12 input, A, B, C, Program and Preview Bus Switcher. It incorporates all the features desirable in a production tool. The unit fills broadcast specifications and can be used in both mobile and studio applications.

All vertical interval switching, 10 wipe patterns, soft wipe, border wipe, key, built-in encoded chroma keyer, downstream matte keyer, and flip-flop autotake are the main features. It is equipped with color background generator, and an independent color background generator in the downstream keyer. The lever mechanism is Geareduction. Operation Panel is 19" (W) x 10.5" (H) x 5" (D). The remote electronics package is 19" (W) x 14" (H) x 16" (D).

- 375 ..... \$14,000.00

## VIDEOTYPEWRITER

### Model 505 Videotypewriter

Model 505 Videotypewriter is a versatile character generator designed for professional use in broadcast studios, CATV stations, and in educational and industrial TV training facilities.

The Model 505 is packaged in a typewriter-style console, and it has been ruggedly designed to withstand many years of constant use.

A unique feature of the Model 505 is the Fontasia Isotropic Font enhancement. Characters are outlined on all edges in white or black. This distinguishes the unit from others which outline characters in only their horizontal or vertical components. Isotropic enhancement produces exceptionally pleasing and easy-to-read characters, regardless of video background.

In addition, the Model 505 Videotypewriter has a sixteen-page memory bank with independent access to program and preview outputs. .... \$4500.00



# MICROPHONE MIXERS



Model M63

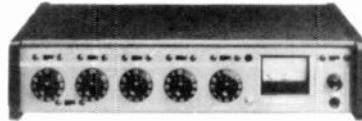

Model M267

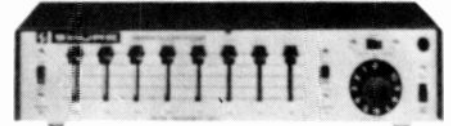

Model M610

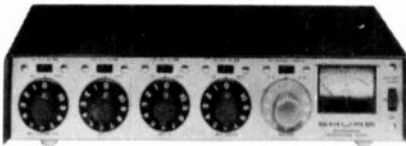

Model M67



Model M64

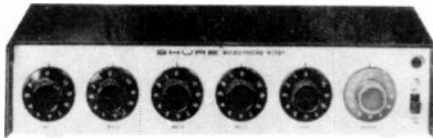

Model M68

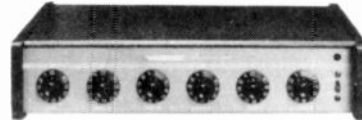

Model M268



Model SE30

## Model M63 Audio Master<sup>®</sup>

A new concept in economical total control of audio response. Can be used in production and transfer studios to equalize sound systems, correct room acoustics, produce special sound effects, reduce stand or stage noise, and for tape recording and duplication. Has two high-level inputs and five output provisions for the greatest response control and flexibility available. Effective, continuously variable high-pass and low-pass 6 dB-per-octave filters, plus separate bass and treble (boost and cut) controls, can be combined for virtually unlimited response characteristics. Output VU meter. Five outputs: high impedance, high level, high impedance mic level, 600-ohm balanced line, and headphone. Two-high-level high impedance inputs controlled by single input attenuator accept signal from virtually any high level source. For 108-132 Volts, 50-60 Hz. \$210.00

## Model M67 Professional Microphone Mixer

The M67 features balanced 600 ohm line and microphone level outputs; an illuminated VU meter calibrated for +4 and +10 dBm out; extremely low noise and RF susceptibility; wide, flat frequency response; two-level headphone monitor jack. AC or battery operation. Noiseless automatic switchover to battery if AC line fails. \$345.00

## M68 and M68FC Microphone Mixer

The backs of the M68 and M68FC Mixers have four Canon-type inputs. Model M68 has MALE Canon XLR-3 type input connectors (uses XLR3-11C type mate) Model M68FC has FEMALE Canon XLR-3 type (uses XLR-3-12C type mate). Each input accepts a dynamic or ribbon microphone (not recommended for crystal or ceramic microphone), either high or low impedance (balanced or unbalanced). Input impedance for each microphone is selected by a slide switch so that microphone types and impedances can be mixed. A fifth input, labeled "AUX," is high level and accepts a tape recorder or tuner signal. When used in conjunction with the A68P Phono Pre-Amp accessory, these mixers also accept a magnetic or ceramic phonograph signal.

M68	\$198.00
M68FC	\$198.00
M68FCE 120 or 240V	\$205.00

## M267 Professional Mixer NEW

Professional mixer for recording or broadcast use. Four low-impedance balanced inputs switchable to mike or line level; simplex (phantom) power on each input; fast-acting limiter; built-in battery supply; headphone amplifier with level control; illuminated VU meter with LED peak level indicator; low-cut filters and tone oscillator; battery check switch; mix bus jack; mic and line level outputs; master volume control; 120 V ac, 50/60 Hz, 9.5 W; battery power; 11-3/8"W x 7-1/2"W x 7-1/2"D x 2-3/4"H \$395.00  
A268R Rack Panel Kit \$21.00

## M268 Microphone Mixer NEW

Five-channel mixer featuring four high/low impedance microphone inputs and one AUX-level input; simplex (phantom) power on each mic input mix bus jack; regulated power supply; 120 V ac, 50/60 Hz, 5 W; 11-3/8"W x 7-1/2"D x 2-3/4"H \$250.00  
A268R Rack Panel Kit \$21.00

## Model M610 Feedback Controller

The M610 gives you the basic advantages of room system equalization — but without the high costs involved in elaborate, complex, highly specialized equalization equipment. The M610 Feedback Controller uses eight resonant dip filters, each controlled by a linear-motion potentiometer. Each of these filters, unlike highly selective "notch" or single-frequency filters, acts on a band of frequencies around its center frequency, so that attenuation is smooth and complete. These filters function in the most critical portion of the audio spectrum, with center frequencies of 63, 125, 250, 500, 1,000, 2,000, 4,000, and 8,000 Hz. Each is infinitely variable from "0 attenuation (flat) to a maximum cut of 12 dB. The M610 also features "high end" (above 8 k Hz) and "low end" (below 63 Hz) roll-off switches to control response outside the range of these filters.

Built-in variable amplification allows the user to conveniently increase the overall gain of the system to a level even higher than original level — even though any or all of the filters have been activated! The M610 also may be used to improve sound quality and increase intelligibility by filtering out "problem frequencies" that cause oscillating ("ringing"), boominess and other disruptive resonances in acoustically difficult rooms. \$214.00

## M64 Series Stereo Preamp

Compact, low distortion, and low noise stereo preamplifiers that provide gain, equalization, and choice of output impedance and levels.

M64 108-132 Volts AC, 50/60 Hz	\$95.00
M64-2E 216-264 Volts AC, 50/60 Hz	\$105.00

## Model SE30 Gated Compressor Mixer

High-quality, "hands-free" gain riding compressor in a single, portable unit. Makes output control in remote pickups, talk shows recording, program line compression and professional sound reinforcement smoother, surer and more trouble-free than it's ever been before. Features, such as: feedback-type gain controls that automatically increase the input clipping level as the individual gain controls are turned down; a built-in low-distortion 1 k Hz tone oscillator; three-function VU meter; stereo parallel jack, self-contained battery and AC power supply, with automatic switch-over to battery in case of AC failure; auxiliary meter light source for battery operation; removable AC line cord; disable switches for compressor and Gated Memory that convert the SE30 to a high quality linear mixer.

Model SE30 Mixer	\$675.00
A100B Rack Panel 3-1/2 x 19"	24.00

## Accessories

A67B Battery Power Supply for M63, M67, M68, M610 May be used as sole power source. On the M67 it may also be used as standby during AC operations providing noiseless switchover in case of AC failure. \$31.50



# PROFESSIONAL MICROPHONES UNIDIRECTIONAL and OMNI DIRECTIONAL

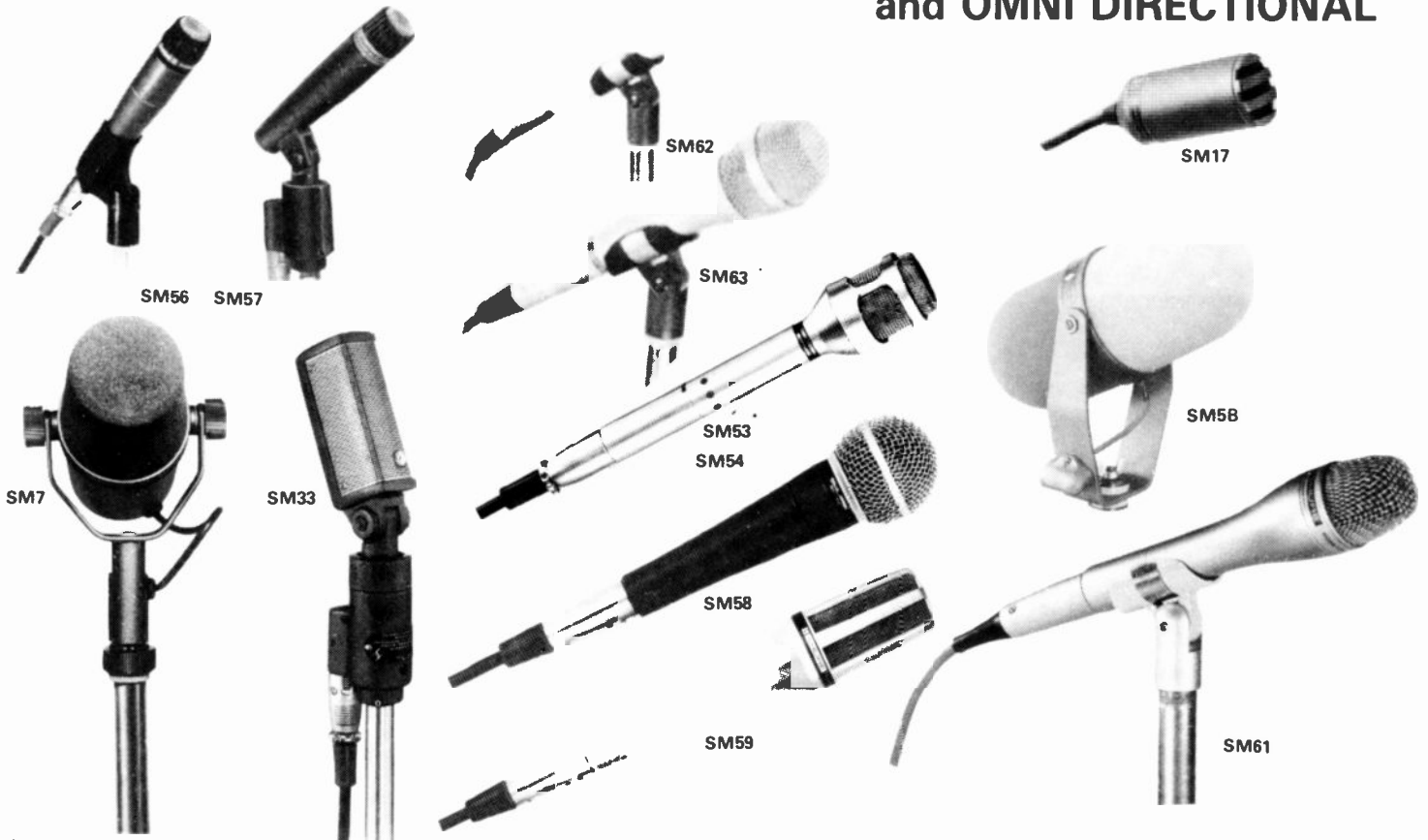

**SM58 Unidirectional Dynamic Boom Microphone**

Specifically designed to minimize boom microphone problems in television and motion-picture sound stage and location recording. Painsstakingly developed to provide extremely high reproduction quality and great flexibility of application.

The SM58 features a wide-range smooth, natural response, especially tailored for dialogue and vocal pickup with excellent presence, yet well-suited to scoring assignments. . . . . \$510.00

**Model SM7:** A dynamic microphone with a very smooth, flat, wide-range frequency response; cardioid polar pattern, uniform with frequency and symmetrical about the axis; internal "air suspension" shock isolation; highly effective pop filter; extremely good rejection of electro-magnetic hum due to a built-in hum rejection system; bass roll-off and mid-range emphasis. The Model SM7 was field-designed to be the finest dynamic microphone available for music recording and reproduction.

**Model SM7** . . . . . \$470.00

**Model SM17:** A miniature dynamic microphone designed specifically for use with acoustic stringed instruments and other acoustic musical instruments. Omnidirectional pickup pattern and frequency response ideally suited for instrument use.

**Model SM17** . . . . . \$95.00

**Model SM33:** A compact and rugged unidirectional ribbon microphone combining wide range response and a supercardioid directional pattern. The performance characteristics are ideal for studio use in broadcasting and recording and for critical sound reinforcement applications. Built-in shock mount for quiet operation. Slotted Response Selector Switch. Frequency response: 40 to 15,000 Hz.

**Model SM33** . . . . . \$325.50

**Model SM51 Dynamic Lavalier Microphone**

Especially designed for radio, TV, or motion-picture applications calling for a small wearable microphone; frequency response optimized for lavalier use—will

match well, in sound, with stand or desk mounted units. Smooth exterior and recessed grille minimize clothing noise. . . . . \$150.00

**Model SM53 and SM54** are designed for professional applications requiring the ultimate in sound quality and control. Broad, smooth frequency response: provides clean, natural reproduction of both voice and music. Cardioid directional pattern: Integral acoustic "pop" filter on the SM54. Mechanical noise isolation. Type: Dynamic. Frequency Response: 70 to 16,000 Hz.

- Model SM53 Bare-ended cable** . . . . . \$300.00
- SM54 Bare-ended cable** . . . . . \$320.00
- SM53-CN (Prewired plug)** . . . . . \$306.00
- SM53-LC (Less cable)** . . . . . \$285.00
- SM54-CN (Prewired plug)** . . . . . \$326.00
- SM54-LC (Less cable)** . . . . . \$305.00

**SM56 and SM57 Unidirectional Dynamics** are slender dynamic microphones built to provide wide range reproduction of music and voice. It features an exceptionally uniform and effective unidirectional pickup pattern. Bright, clean sound. Cartridge shock-mounted for quiet operation. Frequency response: 40 to 15,000 Hz.

- SM56-Stand Mounted** . . . . . \$184.00
- SM57-Hand or Stand** . . . . . \$136.50
- SM57-CN** . . . . . \$142.50
- SM57-LC (Less cable)** . . . . . \$121.50

**Model SM58** is a rugged unidirectional dynamic microphone; self-contained spherical filter to control explosive breath sounds and wind noise; unusually effective cardioid pickup pattern to minimize background noise and undesirable effects of studio and location acoustics. Rear and side rejection uniform to very low frequencies and completely symmetrical about microphone axis; bright, clean sound; cartridge shock-mounted for protection and quiet operation; wind and "pop" filter readily removable for cleaning or replacement. Frequency response: 50 to 15,000 Hz.

- Model SM58 (Bare-ended Cable)** . . . . . \$172.00
- Model SM-58-CN (Prewired plug)** . . . . . \$178.00
- Model SM5858-LC (Less cable)** . . . . . \$157.00

**Model SM59** cardioid dynamic microphone. Essentially flat, wide response. 50 to 15,000 Hz. Patented Mechano-pneumatic shock mount system. Built in "pop" filter, and hum-bucking coil. Durable construction. Ideal for speech, vocal and instrument pick-up, for broadcast, recording and sound reinforcement uses.

- Model SM59-CN** . . . . . \$195.00
- Model SM59-LC (Less cable)** . . . . . \$174.00

**SM60 Omnidirectional Dynamic:** This unusually versatile microphone is a unique combination of beauty, strength, performance and economy. It has smooth, natural, wide-range response for both voice and music.

**Model SM60** . . . . . \$102.00

**Model SM61 Low-Noise Hand-Held Omnidirectional Dynamic:** Combines outstanding noise isolation with a small, lightweight, handsome design especially for hand-held applications in which mechanical shock, wind and cable noises must be controlled.

- Model SM61** . . . . . \$132.50
- Model SM61-CN** . . . . . \$138.50
- SM61-LC (Less cable)** . . . . . \$117.50

**Model SM62 Compact Unidirectional Dynamic:** Shure's tiny SM62 microphone does its own vanishing act—on podiums, in interviews, and on stage. Only 124mm (4-29/32 in.) long, it fits conveniently into the palm of your hand. And it snaps into the SM62's swivel adaptor.

- SM62** . . . . . \$147.50
- SM62-CN** . . . . . \$153.50
- SM62-LC (Less cable)** . . . . . \$132.50

**Model SM63-CN:** Shure omnidirectional microphone, a small lightweight unit, with appearance handling, and performance features ideally suited to highly professional on-camera or on-stage use.

- Model SM63-CN** . . . . . \$120.00
- Model SM63-LC (Less cable)** . . . . . \$99.00





SM76

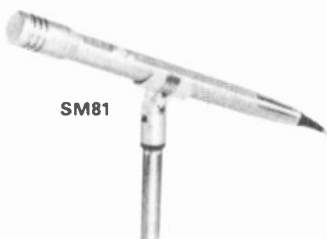

SM81



SM82



SM85



SM78TN

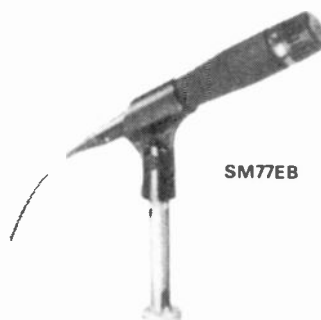

SM77EB

## PROFESSIONAL MICROPHONES UNIDIRECTIONAL and OMNIDIRECTIONAL

### MODEL SM76 3/4" DIAMETER OMNIDIRECTIONAL DYNAMIC

Extremely wide, peak-free, smooth response (45-20 kHz) together with slim styling makes this a microphone of unusual capability. It is recommended for exacting applications in which a very flat, wide-range microphone is required. Ideal for applications as divergent as delicate acoustic guitar and full-throated pipe organ. 45-20,000 Hz, 38 ohms and 150 ohms.  
SM 76.....\$240.00

### SM77 • SM78 UNIDIRECTIONAL DYNAMIC MICROPHONES

The exclusive Shure SUEDECOAT™ finish is more than a color . . . it's an incredible new feel that puts the SM77 and SM78 in a class by themselves. The non-reflective textured finish enables STARMAKER microphones to fit into any picture, but never to outshine the star. What's more, the grille is treated with a Shure exclusive coating which never rusts or tarnishes. Both models are available with or without cable.

The STARMAKER Series has an upper mid-range presence peak for enhanced intelligibility and clean, natural sound that lets a great vocalist stand out from the instruments. The SM78 is a "first choice" microphone for rock, pop, R and B, country, gospel, and jazz vocalists. The SM 77 is especially effective on instrumental pickup where brilliant and defined sound is demanded. 50-15,000 Hz, 150 ohms.

SM77EB-LC (Ebony Matte Finish) less cable	..\$120.00
SM-77EB-CN	..\$141.00
SM77TN-LC (Tan matte finish) less cable	..\$120.00
SM77TN-CN	..\$141.00
SM78EB-LC (Ebony matte finish) less cable	..\$153.00
SM78EB-CN	..\$174.00
SM78TN-LC (Tan matte finish) less cable	..\$153.00
SM78TN-CN	..\$174.00
SM77BR-LC (Brown matte finish) less cable	..\$121.50
SM77BR-CN	..\$142.50
SM78BR-LC (Brown matte finish) less cable	..\$157.00
SM78BR-CN	..\$178.00

Model SM81: A high-quality, unidirectional condenser microphone designed for professional applications in studio recording, broadcasting and sound reinforcement. Especially applicable in situations requiring extremely low wide frequency response, low noise and distortion characteristics, very low RF susceptibility, and reliable operation over a wide range of temperature and humidity extremes.

Model SM81-CN	.....\$348.00
Model SM81-LC (Less cable)	.....\$327.00

Model SM82: Hand-held, self-contained, unidirectional, condenser microphone containing its own line level amplifier, peak limiter, and battery. It is designed to provide a line level output for use in a variety of broadcasting situations, and in sound reinforcement or recording applications where a line level microphone with a built-in limiter is required. Frequency Response: 40 to 15,000 Hz Output Impedance: 250 ohms actual (designed for use with 600 ohm or greater loads)  
Model SM82-LC .....\$300.00

### PS1 and PS1E2 Simplex Power Supplies

The Shure Models PS1 and PS1E2 are AC power supplies that provide simplex (phantom) power for one or two Shure SM81, SM82, SM85, or other condenser microphones. They contain a power switch, power-on indicator, and two three-pin and two three-socket professional audio connectors.

The PS1 and PS1E2 are identical except that the PS1 is designed to operate from 90 to 132 Vac, 50/60 Hz, and PS1E2 operates from 90 to 125 Vac or 180 to 250 Vac, 50/60 Hz (switch selectable). In addition to the voltage selector switch and ac fuse, the PS1E2 is supplied with a detachable ac line cord (without power plug).  
PS1.....\$135.50  
PS1E2 ..... 164.00

### SM85 — Hand-Held Unidirectional Condenser Professional Microphone

The SM85 has a controlled low-frequency rolloff that minimizes mechanical vibrations, handling noise, and the "boominess" sometimes associated with close-up hand-held use.

The response of the SM85 in the important mid-range is especially tailored in the Shure tradition for superb vocal reproduction. It adds "crispness" and presence through carefully placed accentuation in the major voice frequencies. Gives your voice a clear, sharply defined sound that really sets it apart from instrumental backup.

The SM85 offers the professional vocalist clean, clear, scintillating highs which delineate subtle overtones and enhance high-frequency timbre to impart a distinctive, exciting sound to vocal artists. Performers and soundmen who've heard it agree—you can hear the high-end difference.

The three-stage integral wind and pop filter is extremely effective for ordinary wind and breath pop noise. For adverse wind and pop conditions, as in outdoor applications, the SM85 is furnished with an accessory windscreen. In addition, Shure's exclusive elastomer "space-frame" isolates and cushions the SM85 condenser element from virtually all mechanical vibration, including hand-held and stand-borne mechanical noise.

Rugged TEFLON®-coated steel mesh grille is durable and provides cartridge protection and shielding. Three-stage "pop" filter controls explosive breath and wind noises. Condenser element has unidirectional pickup pattern for maximum rejection and minimum coloration of off-axis sounds. Field-effect transistor impedance converter insures low noise and low distortion. Low-frequency rolloff filter minimizes handling noise and proximity effect. Class A amplifier provides low distortion and high output level capability. Power supply regulator allows operation over a wide range of simplex voltages. MUMETAL shield guards against hum and interference from lighting or other electrical equipment. Output transformer minimizes electrical noise pickup from the connecting cable. Vinyl-coated aluminum alloy handle combines lightweight with durability. Radio frequency filter suppresses unwanted pickup from radio, television and communications transmitters. Gold-plated contacts resist corrosion to insure reliable connections. 50-15,000 Hz at 150 ohms (85ohms actual).

SM85	.....\$231.00
SM85-CN	.....252.00
SM80-CN	.....\$348.00
SM80-LC	.....\$327.00

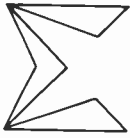

# SIGMA ELECTRONICS INC.

## SYNC AND DISTRIBUTION EQUIPMENT

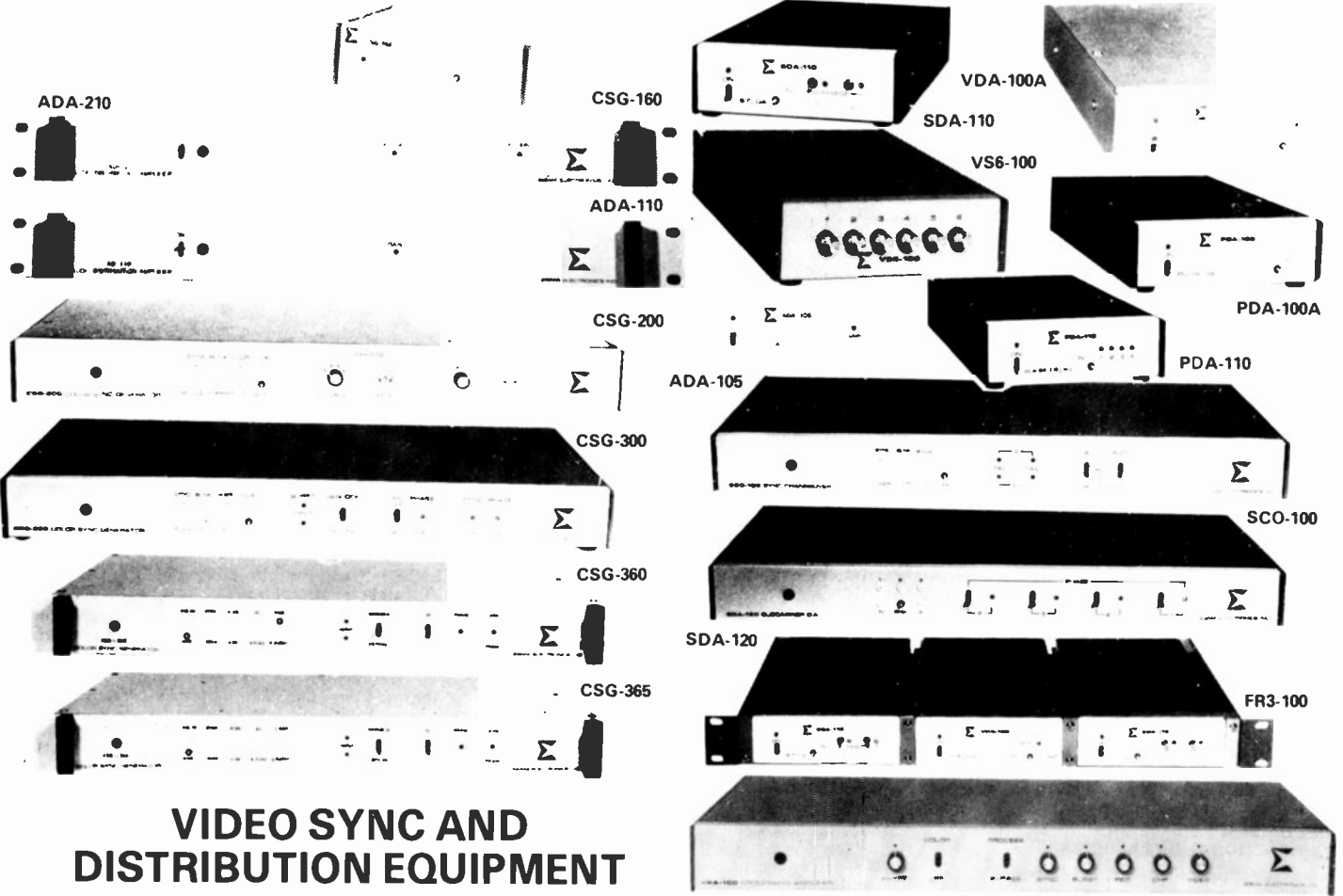

## VIDEO SYNC AND DISTRIBUTION EQUIPMENT

**PDA-110 Pulse Distribution Amplifier** ... \$415.00  
One input, four outputs individually adjustable in delay (from 0.20  $\mu$ Sec to 2.0  $\mu$ Sec)

**PDA-100A Pulse Distribution Amplifier**... \$310.00  
One input/four outputs.

**SDA-110 Subcarrier Distribution Amplifier**  
..... \$390.00  
One input, two outputs individually adjustable in phase from 0° to 360°.

**SDA-120 Subcarrier Distribution Amplifier**  
..... \$700.00  
Same as VDA-110 but with four phase adjustable outputs.

**SCO-100 Sync Changeover** ..... \$600.00  
Automatic and manual.

**FR3-100 Mounting Frame** ..... \$70.00  
Accommodates up to three distribution amplifiers.

**CSG-160 Color Sync Generator**..... \$710.00  
Compact RS-170 capable of mounting in a FR3-100 frame. Proportioned over controlled oscillator. Black burst output. Front panel test points.

**CSG-200 Color Sync Generator** ..... \$900.00  
Same as CSG-160 with three subcarrier outputs, one fixed, two phase adjustable from 0° to 360° in four 90° steps.

### Options for CSG-300

**MOD-300** ..... \$80.00  
Adjustable V&H Blanking Module. Can be plugged into CSG-300 sync generator.

**CSG-360** ..... \$1,350.00  
Genlocking generator including black burst output and adjustable blanking widths.

**CSG-365** ..... \$1,750.00  
Same as 360 but with full field color bar outfit.

**BBG-300** ..... \$122.00  
Color Black Generator Module. Can be added to CSG-300 when ordering a CSG-300.

**VS6-100 Passive Video Switcher** ..... \$115.00  
Six inputs/one output.

**VDA-100A** ..... \$310.00  
One input/six outputs.

## VIDEO PROCESSING AMPLIFIER

**VPA-100 Processing Amplifier** ..... \$1150.00  
Strips and reinserts new sync and burst. Requires Gen/Lock sync generator input for composite sync and blanking and subcarrier.

• Front panel gain controls for video, chroma, sync, burst, pedestal

• 180° front panel phase control

The Sigma Electronics, Inc. Video Processing Amplifier Model VPA-100 has been designed to restore to a standard format the video signal from a helical scan VTR. Being a multifunction amplifier, the VPA-100

will process color or monochrome video signals and provide optimum signal rehabilitation through independent controls of video, chroma, burst, sync and blanking signals. Should there be a loss of input signal, the VPA-100 will automatically provide an internally generated black signal.

## AUDIO DISTRIBUTION AMPLIFIERS

**ADA-210** ..... \$610.00  
Same as ADA-110 except 2 in 20 outputs; 10 per each input.

**ADA-110** ..... \$405.00  
Same as ADA-105 except 10 outputs.

**ADA-105** ..... \$310.00  
Audio distribution amplifier, transformerless, 600 Ohm matching impedance input, five 600 Ohm outputs, 23 dB gain, front panel adjustable.

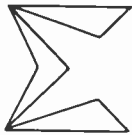

# SIGMA ELECTRONICS INC.

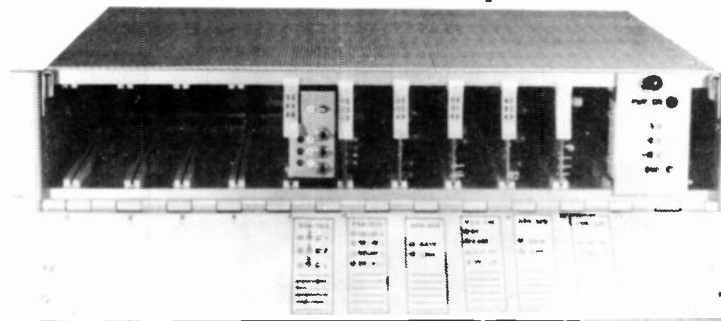
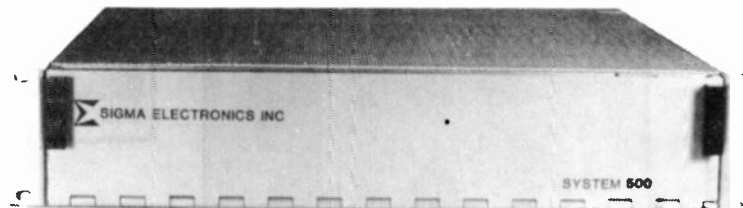

SYSTEM 500

## MODULAR DISTRIBUTION SYSTEM

The Sigma Electronics System 500 is a modular distribution package designed to provide the ultimate in performance, flexibility, and packaging density.

Each FR-500 frame will hold up to ten plug-in modules plus a plug-in power supply, or eleven plug-in modules with external power supply. The exclusive Sigma Interface Adapter System allows the mixing of Audio, Video, Pulse, and Subcarrier Distribution Amplifiers and other System 500 modules in the same frame.

The System 500 modules feature on card regulators to insure maximum system reliability. Modules may be interconnected within the frame by means of the Sigma-Bus Backplane, eliminating the need for cables between modules. All modules include on-board terminating resistors which may be jumper selected, eliminating the need for external terminations.

### FEATURES

- 10 Modules per frame with plug-in power supply; 11 Modules per frame with external supply
- On card regulators for maximum reliability
- Redundant power supply configurations available
- SigmaBus Backplane eliminates need for cabling between modules
- Different types of modules may be mixed in frame

<b>FR-500</b>	Holds 10 modules and PS-501 or 11 modules without power supply . . . . .	<b>\$400.00</b>
<b>PS-501</b>	Power Supply — Powers one FR-500 frame 90-130/180-260 VAC, 50-60 Hz . . . . .	<b>150.00</b>

<b>EX-505</b>	Extender card . . . . .	<b>30.00</b>
<b>VBI-506</b>	Video Bus Interface, direct access to SigmaBus . . . . .	<b>30.00</b>
<b>ABI-507</b>	Audio Bus Interface, direct access to Sigma Bus . . . . .	<b>30.00</b>
<b>BIC-508</b>	Bus Interface Cable, interconnects two frames . . . . .	<b>30.00</b>
<b>VDA-510</b>	Video Distribution Amplifier, One in, six out — Differential Gain less than .1%; Differential Phase less than .2°; Return Loss less than 40 dB to 5 MHz . . . . .	<b>240.00</b>
<b>VDA-511</b>	Video Distribution Amplifier with Sync Add Four Outputs, video and sync inputs — converts non-composite to composite video. Differential Gain less than .1%; Differential Phase less than .2°; Return Loss greater than 40 dB to 5 MHz . . . . .	<b>250.00</b>
<b>ADA-520</b>	Audio Distribution Amplifier, One in, five out — THD less than .1%; Drives 600 Ohm balanced lines to +22 dBm . . . . .	<b>280.00</b>
<b>PDA-530</b>	Regenerative Pulse Distribution Amplifier, One in, six out; less than 100 n sec delay; controlled rise and fall times . . . . .	<b>240.00</b>
<b>PDA-535</b>	Dual Pulse Delay Amplifier, Two independent amplifiers each with two adjustable delayed outputs — 0.20 u sec to 2.0 u sec controlled rise and fall times . . . . .	<b>360.00</b>
<b>SDA-540</b>	Subcarrier Distribution Amplifier, One in, three out; each output individually phase adjustable over 360° range . . . . .	<b>320.00</b>

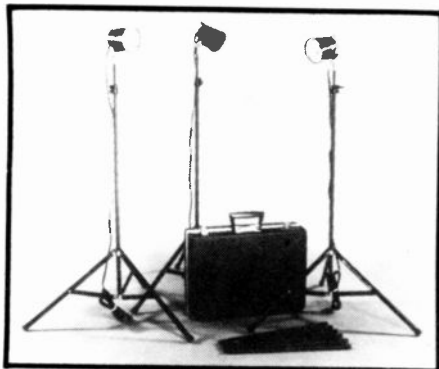

K2R

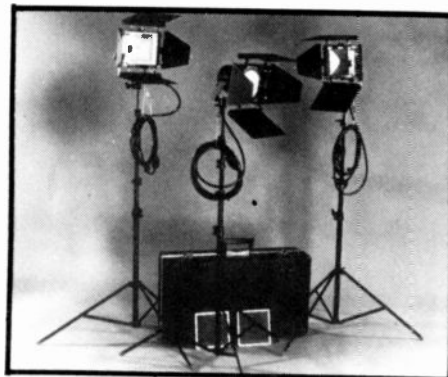

K50

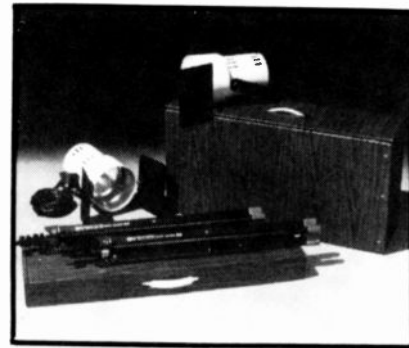

K62



K33



K63

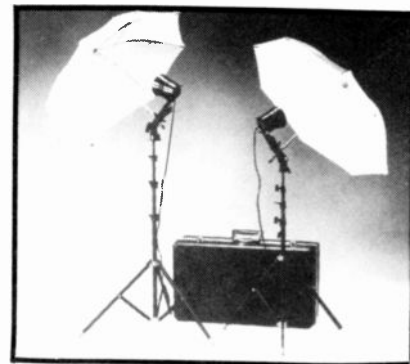

K22U

## LIGHTING KITS

### K2R 1800 Watt Quartz Location Kit **\$295.00**

A complete location lighting kit in an attache case. The most compact 3 light kit on the market with a price to match.

3	700	401101	600 watt quartz units
3	DYH	401928	600 watt 3200°K quartz lamps
3	S6R	401242	6' Steel Stands
1	634L	402202	Carrying Case

Size: 18" x 12" x 6" Weight: 15 lbs.

#### K2R Accessories:

701	401301	Barn doors for 700 quartz unit
C3	661201	Gaffer grip — portable light mount

### K33 1800 Watt Quartz Location Kit **\$499.50**

A complete lighting system at a popular price; contains everything needed for professional results.

3	700	401101	600 watt quartz units
3	DYH	401928	600 watt 3200°K quartz lamps
3	701	401301	Barn doors for 700 quartz units
3	SA28	401233	8' aluminum stands
1	650	402208	Carrying case

Size: 24 1/2" x 14 1/2" x 6 3/4" Weight: 17 lbs.

#### K33 Accessories:

C3	661201	Gaffer grip — portable light mount
----	--------	------------------------------------

### K50 1800 Watt Quartz Location Kit **\$650.00**

Excellent versatility with professional results is offered in this 3-light kit featuring a 600 watt key and 2 600 watt broad fill lights.

1	760	401112	600 watt quartz key unit
2	770	401113	600 watt quartz broad units
3	DYH	401928	600 watt 3200°K quartz lamps
3	771	401325	Barn doors
2	712	401312	Single scrims
3	SA28	401233	8' aluminum stands
1	650	402208	Carrying case

Size: 24 1/2" x 14 1/2" x 6 3/4" Weight: 22 lbs.

#### K50 Accessories:

C5	661202	Gaffer grip — portable light mount	<b>\$24.95</b>
712	401312	Single scrim	<b>\$11.95</b>

### K63 1800 Watt Quartz Location Kit **\$299.50**

3 light kit offers excellent portability and versatility for basic photographic and video applications.

3	Q60	401130	600 watt quartz units
3	DYS/DYV	401970	600 watt 3200°K quartz lamps
3	S9	401240	6' 4-legged steel stands
1		105664	Light case
1		300779	Stand case

Size: Stand case 29 1/4" x 8 1/2" x 2 3/4" Weight: 23 lbs., 10 oz.  
Light case 29 1/2" x 13 3/4" x 8 1/2"

### K62 1200 Watt Quartz Location Kit **\$225.00**

Basic 2 light quartz kit permits professional results in photographic and video applications, offers room for additional light and stand to be added at a later date.

2	Q60	401130	600 watt quartz units
2	DYS/DYV	401970	600 watt 3200°K quartz lamps
2	S9	401240	6' 4-legged steel stands
1		105664	Light case
1		300779	Stand case

Size: Stand case 29 1/4" x 8 1/2" x 2 3/4" Weight: 17 lbs., 1 oz.  
Light case 29 1/2" x 13 3/4" x 8 1/2"

### K22U 1200 Watt Quartz Location Kit **\$320.00**

An excellent starter for the serious amateur photographer or videographer offers room for additional accessories.

2	700	401101	600 watt quartz lamps
2	DYH	401928	600 watt 3200°K quartz lamps
2		670002	32" white umbrellas
2		670033	Combination light and umbrella mounts
2	S7	401239	6 ft. steel stands
1	650	402208	Carrying case

Size: 24 1/2" x 14 1/2" x 6 3/4" Weight: 15 lbs., 10 oz.

#### K22U Accessories:

701	401301	Barn Doors for 700 Quartz unit
C3	661201	Gaffer grip — 3/8" portable light mount

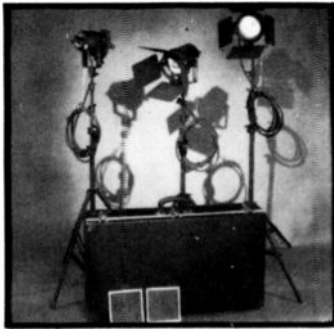

K71

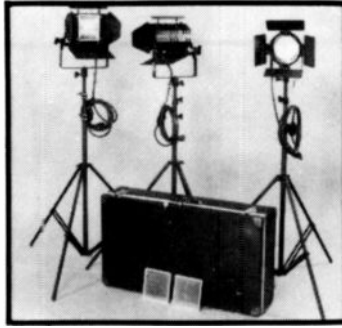

K74



K76



K73

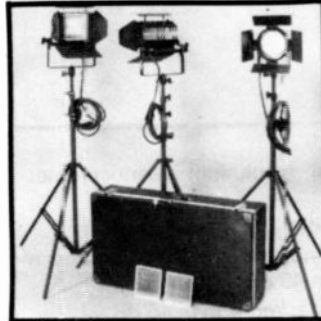

K75



## LIGHTING KITS

### K71 1800 Watt Professional Focusing Quartz Location Kit

**\$850.00**

Versatility is the key word in this professional quartz lighting kit featuring the flexibility of 3 focusing units which allow smooth transition from spot to flood.

3	710	401102	600 watt focusing quartz lamps
3	DYH	401928	600 watt 3200°K quartz lamps
2	711	401307	Barn doors
2	712	401312	Single scrims
3	SA10	401235	10' aluminum stands
1	674	402206	Carrying case

Size: 29" x 18" x 8" Weight: 28 lbs.

#### K71 Accessories

711	401307	Barn doors
712	401312	Single scrim
C5	661202	Gaffer grip — portable light mount

### K72 1900 Watt Professional Quartz Location Kit

**\$875.00**

Key in on the action with this professional kit featuring a 600 watt focusing unit and 2 650 watt broad units. Ideal for smaller set applications.

2	740	401104	650 watt quartz broad units
2	FBX	620050	650 watt 3200°K quartz lamp
2	742	401319	Single scrims
1	710	401102	600 watt focusing quartz unit
1	DYH	401928	600 watt 3200°K quartz lamp
1	711	401307	Barn doors
3	SA48	401234	8' aluminum stands
1	674	402206	Carrying case

Size: 29" x 18" x 8" Weight: 30 lbs.

#### K72 Accessories

712	401312	Single scrim
C5	661202	Gaffer grip — portable light mount
	401260	30" Stand Extension

### K73 3000 Watt Professional Focusing Quartz Location Kit

**\$950.00**

Extra coverage and reach are provided in this kit featuring 3 1000 watt focusing units.

3	720	401103	1000 watt focusing quartz units
3	FBY	620140	1000 watt 3200°K quartz lamps
2	721	401308	Barn doors
2	722	401316	Single scrims
3	SA48	401234	8' aluminum stands
1	674	402206	Carrying case

Size: 29" x 18" x 8" Weight: 32 lbs.

#### K73 Accessories

721	401308	Barn doors
722	401316	Single scrim
C5	401260	Gaffer grip — portable light mount 30" Stand Extension

### K74 3000 Watt Professional Quartz Location Kit

**\$975.00**

Our most powerful 3 unit lighting kit offers the versatility and flexibility of 2 1000 watt broad units and a 1000 watt focusing unit.

2	750	401105	1000 watt quartz broad units
2	FHM	620380	1000 watt 3200°K quartz lamps
2	752	401322	Single scrims
1	720	401103	1000 watt focusing quartz unit
1	FBY	620140	1000 watt 3200°K quartz lamp
1	721	401308	Barn doors
3	SA48	401234	8' Aluminum stands
1	674	402206	Carrying case

Size: 29" x 18" x 8" Weight: 34 lbs.

#### K74 Accessories

722	401316	Single scrim
C5	661202	Gaffer grip — portable light mount
	401260	30" Stand Extension

### K75 2500 Watt Professional Quartz Location Kit

**\$1150.00**

Everything you need and more is found in this Smith-Victor 4 light kit. Two each focusing and broad units provide excellent lighting for both studio and location use in photographic and video applications.

2	740	401104	650 watt quartz broad units
3	FBX	620050	650 watt 3200°K quartz lamps
2	742	401319	Single scrims
2	710	401102	600 watt focusing quartz unit
3	DYH	401928	600 watt 3200°K quartz lamps
2	711	401307	Barn doors
2	712	401312	Single scrims
4	SA48	401234	8' aluminum stands
1	674	402206	Carrying case

Size: 29" x 18" x 8" Weight: 35 lbs.

#### K75 Accessories

712	401312	Single scrim
C5	661202	Gaffer grip — portable light mount
	401260	30" Stand Extension

### K76 4000 Watt Professional Quartz Location Kit

**\$1325.00**

A winning combination is found in this, Smith-Victor's most complete lighting kit. The pairing of 2 1000 watt focusing and 2 1000 watt broad units make this Smith-Victor's most versatile and powerful kit.

2	750	401105	1000 watt quartz units
3	FHM	620380	1000 watt 3200°K quartz lamps
2	752	401322	Single scrims
2	720	401103	1000 watt focusing quartz units
3	FBY	620140	1000 watt 3200°K quartz lamps
2	721	401308	Barn doors
2	722	401316	Single scrims
4	SA48	401234	8' aluminum stands
1	674	402206	Carrying case

Size: 29" x 18" x 8" Weight: 41 lbs.

#### K76 Accessories

C5	661202	Gaffer grip — portable light mount
	401260	30" Stand Extension



## U-MATIC RECORDER

### VO-5850 Professional Editing U-Matic Recorder

#### Features

- New front loading tape transport
- Aluminum diecast chassis
- Drum and capstan direct drive
- Digital servo LSI with "Phi Square Servo"
- DC motor reel servo
- Sophisticated editing with full RM-440 interface
- Bidirex dial search + /-1/30~x5, 15 different speeds
- High speed picture search (with RM-440 and KCS tape)
- LED tape timer with mark-in function
- Built-in preroll editing capability
- Noiseless still
- Accurate editing + /-2 frames with one preview
- New power supply with switching regulator, wide range of voltage, frequency and low power consumption — 75W
- 19" rack mountable
- Loop through video input with 75 Ohm termination switch
- 2 video output connectors — BNC
- Tilt-out control panel
- High picture quality

#### Specifications

##### System

Video recording: Rotary two-head helical scan system

Luminance: fm recording

Color signal: converted subcarrier direct recording

Video signal system: EIA standards, NTSC color

##### Video

Video Input: VIDEO IN, BNC type, x2 with 75 Ohm termination switch and loop-through output. 1.0 V (p-p) +1.0-0.5 V (p-p), 75 Ohms, unbalanced, sync negative. DUB IN, 8 pin, x1 TV, 8 pin, x1

Video Output: VIDEO OUT, BNC type, x2. 1.0 V (p-p) +0.2 V, 75 Ohms, unbalanced, sync negative DUB OUT, 7 pin, x1 TV, 8 pin, x1

Horizontal resolution: Monochrome: 340 lines

Color mode: 260 lines

Signal-to-noise ratio: Monochrome mode: more than 49 dB

Color mode: more than 46 dB

Subcarrier: SCIN, BNC type, x1.2 V (0.5-3V) (p-p), 75 Ohms, unbalanced, sync, negative Sync: EXT SYNC IN, BNC type, x1.4 V (25V) (p-p), 75 Ohms, unbalanced, sync negative

Recording level: Automatic and manual

#### Audio

Audio Input: LINE CH-1, CH-2 IN, Phono jack, x1 in each -10 dB, 47 k Ohms. MIC CH-1, CH-2, Phone jack, x1 in each. -60 dB, for 600 Ohm microphones TV, 8 pin, x1

Audio Output: LINE CH-1, CH-2 OUT, Phono jack, x1 in each -5 dB (with 47 k Ohms load). HEADPHONES, Stereo phone jack, x1 for 8 Ohm headphones

Level: adjustable (-24 dB to -46 dB). TV, 8 pin, x1

Signal-to-noise ratio: Better than 48 dB (at 3% distortion) Both channels 1 and 2

Frequency Response: 50 15,000 Hz (channels 1 and 2)

Recording level adjustment: Manual, with audio limiter

#### Edit

Assemble: Video and audio channel 1 and audio channel 2 (simultaneously)

Insert: Video, audio channel 1 and/or audio channel 2 independently (selectable)

Preroll: possible

Automatic editing: Possible with the RM-440 Automatic Editing Control (optional)

Accuracy: + /-2 frames

#### Special Instructions

Pause: A still picture is obtained, with long pause function

Search: Possible (still, and 1/10 to 5 times of normal speed in forward and reverse directions). Picture search is possible with the RM-440 when KCS tape is used

Tracking control: Possible

Skew control: Possible

Sync System: Internal and external

Vertical-interval switcher: Internal

Dropout compensator: Internal

#### Tape Transport

Tape speed: 3-3/4 ips (9.53 cm/sec)

Recording or playback time: 60 min (with KCA-60)

Fast forward and rewind time: within 4 min (with KCA-60)

Wow and flutter: 0.2% RMS

Tape compatibility: U-Matic videocassette tape

Usable tape: KCA, KCS type tape

#### General

Power requirements: 100-120 V AC + /-10%, 50/60 Hz + /-10%

Power consumption: 75 W with RM-440

AC OUT: 400 W maximum, unswitched

Operating position: Horizontal

Storage temperature: -4°F to + 140°F (-20°C to +60°C)

Operating temperature: 41°F to 104°F (5°C to 40°C)

Dimensions: 9-3/8" x 17-5/8" x 20-1/2" (HWD), 237 x 446 x 518mm (HWD) including projecting parts and controls

Weight: 55 lb. (25 kg)

Supplied accessory: AC power cord

#### Optional Accessories

RM-440 Editing Control Unit

Sony CVM and PMV Series Color Video Monitors

Sony DXC Series Color Video Cameras

RX-353 Auto Search Control

RX-303 Auto Search Control

KCS-1C Cleaning Cassette

RCC-5F Remote Control Cable

VDC-5 Dubbing Cable (5 m)

Monitor Connecting Cables: VMC-3P (3 m),

VMC-5P (5 m), VMC-10P (10 m)

Video Responder System: VRC-100, VRS-

100, VRD-100, VRP-100

Price

\$7,250.00

# SONY

Sony Video Communications

## U-MATIC RECORDER

### VP-5000 U-matic Player

The most convenient and versatile U-matic player ever made. Up front controls and indicators, an all new front loading tape transport and standard EIA rack mounting head the list of exterior improvements. Inside, there's new technology with advances in the drive components, power supply and control circuits.

#### Features

- New front loading tape transport • Aluminum diecast chassis
- Direct drive for both drum and capstan • Digital servo LSI with "Phi Square Servo" • DC motor reel servo • x5 forward and reverse search • Noiseless still — Fine still picture • 19" rack mountable
- High picture quality • Tilt-out control panel • New switching regulator power supply provides wide range of voltage and frequency, with low power consumption — 45W • Exclusive connector for RX-303 • Random access/interactive capability • Micro-computer based logic control

\$1895.00



VP-5000

### VO-5600 U-matic Recorder

A new generation of U-matic recorder with new all time high levels of performance and flexibility. Totally redesigned around a new front loading tape transport, the unit has a super-functional, tilt-out control panel and is 19" rack mountable. New circuitry and components further enhance the reliability and accuracy of video's most relied-on format.

#### Features

- New front loading tape transport • Aluminum diecast chassis
- Direct drive for both drum and capstan • Digital servo LSI with "Phi Square Servo" • DC motor reel servo • x5 forward and reverse search • Noiseless still — Fine still picture • 19" rack mountable
- High picture quality • Tilt-out control panel • New switching regulator power supply provides wide range of voltage and frequency, with low power consumption — 55 W • Exclusive connector for RX-353 • Random access/interactive capability • Micro-computer based logic control

\$2350.00

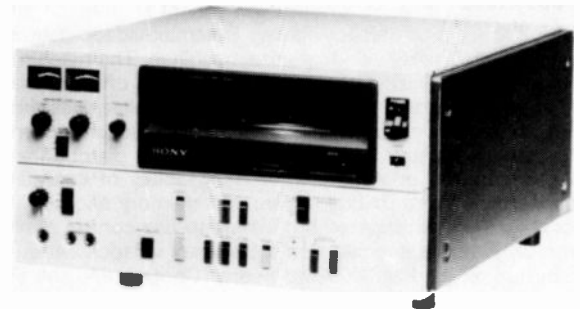

VO-5600

## VIDEOCASSETTE RECORDER

### VO-5800 Videocassette Recorder

Sony expands the upgraded Type 5 U-matic system with another convenient new recorder. Compact and even more lightweight than the VO-5850 Editing Recorder, the VO-5800 offers the same professional quality and design, with front-loading tape transport, and allows smooth manual editing. It can be used alone; or as part of a sophisticated, rack-mountable automatic editing system.

- Front loading tape transport • Aluminum diecast chassis • Direct drive of both drum and capstan • Digital servo LSI with "Phi Square Servo" • DC motor reel servo • Backspace edit capability • Vertical interval switch between two video inputs • Feeder capability with full RM-440 interface • Bidrex dial search, +/- x1/30 to x5 • U-scan, high speed picture search (with RM-440 and KCS tape) • LED tape timer with mark-in/mark-out function • Switching regulator power supply provides wide range of voltage and frequency and low power consumption — 75W • Noiseless still • 19" rack mountable • Tilt-out control panel • High picture quality • Exclusive connector for RX-353 • Random access/interactive capability • Video Recording: Rotary two-head helical scan system • Luminance: FM recording • Color Signal: Converted subcarrier direct recording • Video Signal System: EIA standards, NTSC color

Price on Request



VO-5800

# SONY

Sony Video Communications

## VIDEOCASSETTE UNITS

### Betamax



SLO-383



SLO-340



SLO-323



SLP-303

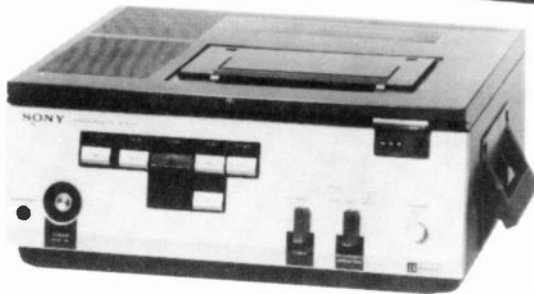

SLP-300

### SLP-300 Betamax® Videocassette Player

The SLP-300 is a new unit for playing Betamax videocassettes. One of series of "intelligent" videocassette machines. The machines from the Betamax 300 series. The Betamax 300 series offers all the basic Betamax advantages. Quality recording, on smaller, less expensive videocassettes. Lower equipment costs, and the security of mechanisms proven in the field. Reduced shipping and distribution costs. Simple, one-button operation. Interchangeability of cassettes. 300 series machines add a unique advantage: memory access. Memory access means a sophisticated but simple-to-use control system that electronically locates any point on a Betamax videocassette. Push a single button on the RM-300 Auto Search Control, and the SLP-300 automatically finds and plays the program or program segment you choose. To replay a segment, all you have to do is touch the same button: the SLP-300 will stop the tape, rewind, and begin playing again — all by itself. **\$ 995.00**

### SLP-303 Betamax Videocassette Recorder

The new Betamax SLP-303 Player is the first institutional ½" machines to incorporate high-speed picture search. With Sony's Beta-Scan system, you actually see the picture as you search for a particular section of tape. At up to 15 times normal speed in the forward mode and up to 10 times normal speed in rewind.

You also get noiseless playback at twice normal speed. And noiseless still frame. You can even advance the picture frame by frame for detailed scrutiny.

The SLP-303 player has dual-channel audio. But the most revolutionary feature is the way the SLP-303 can be used with the RX-353.

**\$1295.00**

### SLO-323 Betamax® Videocassette Recorder

The SLO-323 is a Betamax recorder/player with new features that add dramatically to the capabilities of the Betamax system and secure its position as the most versatile and effective video format for education and training, sales demonstration, corporate communications and a variety of other uses. **\$1595.00**

### SLO-323MD

½" color videocassette recorder/player for medical applications. Has UL-544 approval. **\$1890.00**

### SLO-340 Betamax® Portable Videocassette Recorder

The SLO-340 is a new, portable unit for recording and playing back Betamax videocassettes. It weighs less than 20 lbs., and will record in either color or black and white for up to 90 minutes on its internal lightweight battery pack. The SLO-340 offers all the basic Betamax advantages. Quality recording on smaller, less expensive videocassettes. Lower equipment costs, and the security of equipment proven in the field. Lower shipping and distribution costs. Simple one-button operation and interchangeability of cassettes. Add a super self-contained portable color camera like the new Sony DXC-1610, and you're ready to record anywhere on Betamax. There's even an economical black and white camera, the AVC-3450, for video projects on a limited budget. **\$1395.00**

### SLO-383 Editing Betamax® Videocassette Recorder

The SLO-383 is an editing Betamax recorder/player with new features that make the Betamax system even more effective for education and training, sales demonstration, corporate communications and a variety of other uses.

New Beta-Scan high-speed picture search ability helps you find what you want while viewing coherent picture at up to 15 times normal in the forward mode and up to 10 times normal in reverse (average speed in forward and reverse is 8 times normal).

The SLO-383 offers full editing capability, including edit preview, when used with the RM-430 Automatic Editing Controller. Video, Audio 1 or Audio 2 may be selected independently for insert editing, or handled simultaneously in assembly editing. Dubbing connectors let you work easily in both Beta and U-Matic formats.

The design of the SLO-383 assures top-rate performance. Direct-drive power for both head drum and capstan maintain precise tape alignment and smooth play, with video signal-to-noise ratio at 45 dB in color mode. **\$3750.00**

### SLO-383PAC

Contains 2 SLO383, 1 RM-440, 1 VDC-5 and 2 RCC5F **\$8750.00**

### SL-5800 Betamax® Videocassette Recorder

The SL-5800 brings more features to video recording and playback convenience than ever before. Now, with Variable BetaScan, you can search in CUE (fast forward) or REVIEW (reverse) at speeds from 5 to 20 times normal to see what you're looking for and stop when you find it.

Sony's SL-5800 also gives you a Freeze-Frame that's crystal clear and optically true. And with the Time Commander Remote Control, you can command other playback features like: Variable BetaScan, Frame-by-Frame picture advance, Variable Slo-Motion to ½ Normal speed, and 3x Fast Play to get a good look at all the detail while going through your tape quickly.





**VO-4800**

**VO-4800 Portable Color Videocassette Recorder/Player**

Lightweight portability and advanced features combine for easy, efficient on-the-spot recording and field production • Three-way power operation — AC-340B AC Power Adaptor (included), BP-60 Battery Pack (optional), DCC-3000 Car Battery Adaptor (optional) • 150 minutes of continuous operation with battery pack and up to 60 minutes while also powering a DXC-1640 portable color camera • Automatic back-space editing with framing servo — reverse at each recorded frame and smooth butt edit with the next segment shot — plus assemble edit capability from two video sources • Fast picture search in fast forward or rewind mode • Still frame capability in PAUSE mode • Complete compatibility with optional equipment for playback or editing with any other standard U-matic videocassette unit • Built-in RF unit for playback on conventional TV receiver • Immediate display

of the recorded picture on the DXC-1640 camera viewfinder • Camera-trigger operation to start and stop recording • Automatic Gain Control maintains optimum video and audio levels, and audio level can also be adjusted manually • Three-way meter to check video and audio signal levels plus battery charge • Dual audio tracks • Audio dubbing facilitates sound-track changes or additions • Safeguard warning system with visual LED and audible (through earphone) beep tone to signal; low battery power; moisture condensation; tape slack; incorrect servo lock; and end of tape. With the DXC-1640, the beep alarm sounds through the earphone, and LED signals are visible through the viewfinder • Weight: 17 lbs. 10 oz. (w/o battery pack) • Dimensions: (Recorder) 5-1/8" x 13-1/4" x 13-7/8" (HWD) **\$3250.00**

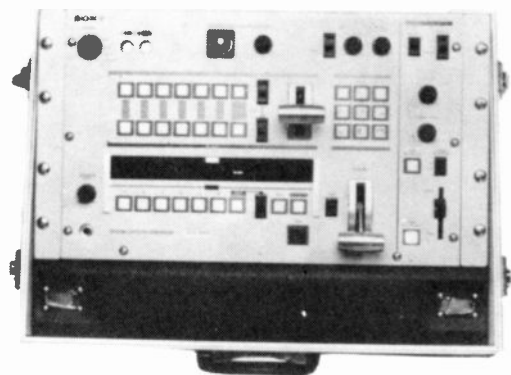

SEG-2000



MD-1600



CG-101

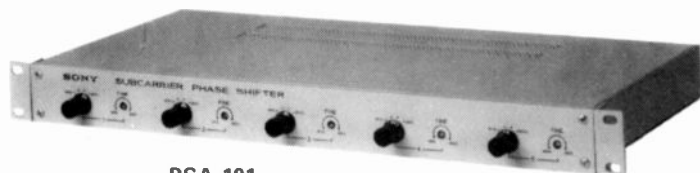

PSA-101

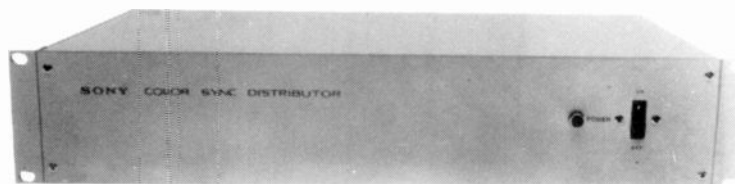

DA-101

**SEG-2000**  
**Portable Color**  
**Special Effects Generator**

A totally self-contained and portable special effects generator that is ideal for use in field operations. It operates on battery, external DC or AC power, and provides so much versatility and sophistication that it can even be taken into the studio for editing, or on-line switching.

Built-in NTSC sync generator with Gen-Lock capability. Operates up to 2.5 hours on two optional battery packs. Three-way operation: AC, external DC and battery packs. "SC and H phase adjust" indication eliminates need for a vectorscope and a waveform monitor. Optional carrying cases for the SEG-2000 and camera control units, cuts set-up and shipping time. Four output bus lines: A and B special effects bus, Preset and Program bus. Auto take switch and PGM/PST MIX lever for cut and dissolve between PGM and PST pictures. Six video inputs and one auxiliary input. MIX, EXT, KEY and WIPE between any pictures on A and B bus. Six wipe patterns with choice of hard wipe, soft wipe and border wipe plus adjustable softness and border width. Built-in downstream keyer with shadow generator. Built-in background generator: black, white or any color. Black burst outputs. Self-illuminating buttons.

SEG-2000 Special Effects Generator **\$4940.00**

**PSA-101**  
**Color Phase Shifter**

The PSA-101 is an important addition to any multi-camera production system. It works along with the DA-101 Distribution Amplifier to insure smooth transitions between up to five color cameras. It is a highly advanced unit designed to correct subcarrier phase differences commonly caused by special effects generators and camera cables of varying lengths. Independent selector knobs phase each camera's output over the entire 360° range in basic steps, allowing most phase corrections to be accomplished on a monitor by comparing SEG input and output. The PSA-101 adapts to most video cameras. Weight: 6 lbs. 10 oz. Dimensions: 1-13/16" x 18-7/8" x 9-7/8" (HWD).

PSA-101. Color Phase Shifter. **\$400.00**

**MD-1600**  
**Multi-Signal Distributor**

Multi-signal distributor for Tricon cameras. Includes color sync generator (accepts EXT sync). Sync distributor. Sub-carrier phase shifter. Color bar generator. Cable compensator. Tally intercom. Return video facility. Weight: 40 lbs. 6 oz. Dimensions: 7" x 18-7/8" x 16-7/8" (HWD).

MD-1600. Multi-Signal Distributor. **\$3500.00**

**CG-101**  
**Color Sync Generator**

The CG-101 Color Sync Generator is a compact unit that delivers NTSC standard sync signals to color and monochrome equipment in any multi-component production system. The signal source is incredibly accurate, governed by a crystal controlled 3.579545 sine wave oscillator. Advanced circuitry assures syn-locked, distortion-free transitions between video sources. Adaptable to mobile production or permanent studio installations. Weight: 7 lbs. 11 oz. Dimensions: 2-3/8" x 16-1/2" x 10-3/8" (HWD).

CG-101. Color Sync Generator. **\$1100.00**

**DA-101**  
**Color Sync Distributor**

The DA-101 Color Sync Distribution Amplifier is designed for use with the CG-101 Color Sync Generator and assures output compatibility within any multi-component color or monochrome production system. The DA-101 delivers blanking, vertical drive, horizontal drive, sync and burst flag signals along with a 3.58 MHz subcarrier pulse to up to 5 cameras through standard 10-pin connectors. A direct sync output allows for almost unlimited system synchronization. Weight: 11 lbs. 0 oz. Dimensions: 3-1/2" x 7-1/16" x 9-3/16" (HWD).

DA-101. Color Sync Distributor. **\$500.00**

# SONY

Sony Video Communications

## VIDEO RESPONDER INTERACTIVE LEARNING SYSTEM

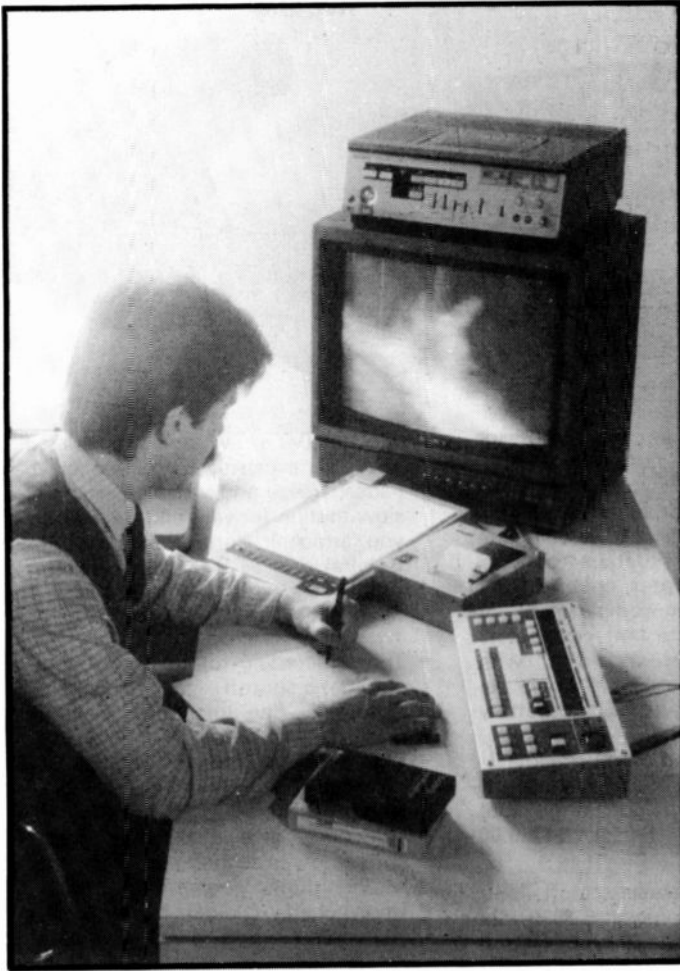

The Sony Video Responder is a microcomputer-based learning system specifically designed for interactive programming. The system utilizes videocassette programs and consists of a random access Sony Betamax or U-matic player, monitor, responder unit and optional printer.

### FEATURES

- **Components:** Random Access U-matic or Betamax Player  
Monitor  
Responder Unit  
Cue Programmer  
Optional Printer
- **Program Units:** Program — Basic unit of responder material. Up to nine are contained in a single videotape.  
Segment — Division of a program. Up to fourteen per program.  
Branch — Segment which is accessed only if additional instruction by the Sony Video Responder was requested.

- **Available Question Design Strategies:**  
Multiple choice  
Sequence selection  
Direct numerical entry  
Up to nine entries per question
- **Available Responses:** Spelled responses possible with special key. Questions can be coded to require answers in the form of diagrams, shapes, colors and letters.  
Key entry order can be designated important or not important.
- **Advantages:** Simplified for use by non-technical personnel.  
Several question modes possible.  
Easy to program with the Cue Programmer.  
Uses standard and existing videotape programs.

### VCR-100 PROGRAMMER

**Power Requirements:** 6.5 V DC (supplied from the videocassette recorder).

**Power Consumption:** 5.2 W

#### Indicator:

TAPE POSITION . . . . .	4 digits (max. 99 min. 59 sec.)
PROGRAM . . . . .	1 digit (1 to 9 and E)
SEG/BR . . . . .	2 digits (1 to 14)
SEGMENT . . . . .	2 digits (1 to 14)
QUESTION . . . . .	1 digit (1 to 9)
BRANCH . . . . .	1 digit (0 or 1)
ORDER . . . . .	1 digit (0 or 1)
ANSWER . . . . .	9 digits (0 to 9)

**Standard Signal:** Control-track signal recorded on the tape.

**Data Output Level:** -15 dB +/- 1.5 dB (0 dB = 0.775 V rms).

**Weight:** 15 lbs. 6 oz. (6.8 kg.)

**Dimensions:** 2-3/4" x 16-7/8" x 7-1/2" (HWD) 68mm x 426mm x 188mm (HWD).

VRC-100 Cue Recorder (for programming tapes for use with VRS . . . . .	\$2000.00
VRS-100 Video Responder Unit . . . . .	675.00
VRS-110E/S Video Responder Unit (Bilingual-English/Spanish display . . . . .	\$775.00
VRP-100 Printer for VRS and VRC . . . . .	625.00

# SONY

Sony Video Communications

SL-2000

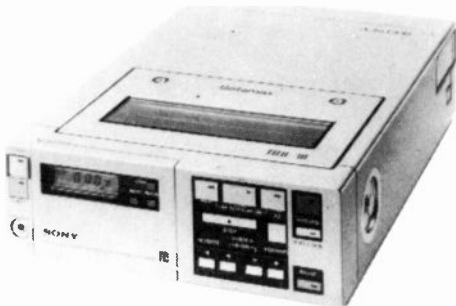

## SL-2000 VCR

### Features:

- Versatile component design makes BetaPak perfect for both home video recording use and portable recording indoors or outdoors.
- The world's smallest, lightest, most compact 1/2" video recorder; all-new chassis design, direct-drive motor mechanism, and integrated circuitry allow ultra-miniature design for space-saving home use, comfortable field recording.
- BetaScan-II®, the new Betamax picture search breakthrough that gives you full search capabilities at fast, normal and slow speeds in both directions — CUE (fast forward), REVIEW (reverse), plus VIDEOLA®; continuous search in both forward and reverse at normal speed and slow motion, frame-by-frame advance, and freeze frame, for pinpoint search accuracy and professionally precise edits.
- New RECORD/REVIEW feature for recording with Sony's HVC-2200 portable color video camera; a single button stops the tape, rewinds and plays back the last few seconds of your recording, and pauses in readiness for your next show — and you get a clean, clear, noise-free transition between scenes.
- New Timing Phase Circuitry to assure smooth picture transitions and eliminate picture breakup at transition points between recorded segments for both pauses and stops.
- 2X Fast Play capability for quick review of your recording.
- 5 hours of recording time with Sony L-830 Betamax videocassette; record in Beta II or Beta III modes; playback in Beta I, Beta II, and Beta III modes automatically.
- A liquid crystal multi-function display includes a linear time counter, showing hours, minutes and seconds, Beta I, II and III playback/record mode indicator, dew condensation indicator and tape run direction indicator.
- Simple hand-held video remote control (RM-311) as an optional accessory for additional convenience while recording in any on-location or home situation.

TT-2000



- Feather-touch full logic microprocessor controls.
- Audio dubbing to let you create new commentary, music, or sound.
- Three-way power supply allows complete portability in every situation: optional AC-220 AC power adaptor, optional NP-1 battery pack in built-in compartment, or optional DCC-2400B car battery adaptor.
- One-hour continuous recording with fully charged NP-1 battery; 4 hours recording with optional BCP-220 4-battery pack case.
- Auto rewind at the end of your tape.
- Moisture sensor automatically shuts off operating capability when excess moisture is present. **\$1150.00**

### Accessories:

Supplied: Betamax Videocassette (L-165), Shoulder Strap, Earphone (ME-20H), 2x Antenna Connector Cables (F-type; 60 and 20 inches), 2x External Antenna Connectors (EAC-24 and EAC-25), Antenna Selector (ANS-20).

Optional: Tuner/Timer Unit (TT-2000), AC Adaptor (AC-220), Battery Pack, (NP-1), Battery Charger (BC-220), Four Battery Pack Case (BCP-220) Video Remote Control (RM-311 wired for portable) Car Battery Cord (DCC-2400B), Hard Carrying Handle (AH-220), Soft Carrying Case (LC-230), Adaptor Cable (VMC-220).

## TT-2000 Programmable Tuner/Timer

### Features:

- Ultra-compact styling to match BetaPak SL-2000 recorder; units may be positioned side by side or stacked.
- 14-pushbutton Express Tuning to give you the VHF or UHF channel of your choice with just a single light fingertip touch.
- Semi-automatic channel presetting; channels may be matched to pushbuttons in any order, even VHF and UHF channels intermixed.
- Wireless Infrared Remote Commander-RMT-311 (Supplied) operates power on/off, channel up/down selection, program

# BETAPAK VIDEOCASSETTE RECORDER

HVC-2200



- selection (VTR/TV), recording, play, F.F., REW, Betascan®, stop, fast playback, pause, freeze and Videola® (normal and slow-motion forward and reverse) to give you armchair control of both SL-2000 BetaPak and TT-2000 Tuner/Timer.
- 2-week/4-event programmable timer for automatic recording even when you're away from home.
- Timer recording for up to 5 hours with automatic shutoff.
- Automatic fine tuning for clean, clear, noise-free picture.
- Acts as AC adaptor for BetaPak SL-2000 recorder.
- Recharges BetaPak NP-1 battery.
- 10-minute power backup advances clock and preserves accurate programmed timer settings during power interruption.
- Unswitched AC outlet for TV receiver. **\$350.00**

### Accessories:

Supplied: Wireless Remote Commander (RMT-311), External Antenna Adaptor (EAC-24; 75 ohm to 300 ohm matching transformer), External Antenna Adaptor (EAC-25; 300 ohm to 75 ohm matching transformer), 75 ohm coaxial cable with F-type connector (60"), 300 ohm ribbon-type lead-in (80"). Channel Number Segments.

## HVC-2200 Portable Color Video Camera

Full-feature video camera that gives you great picture quality indoors or outdoors. Operates with Betamax portable and home video cassette recorders (excluding SL-7200). 2/3" MF Tricon tube developed by Sony for sharper resolution and color clarity. Built-in electronic viewfinder with 1 1/2" TV picture tube that shows you exactly what you're recording. High quality 6-to-1 ratio f1.8 Cannon zoom lens with manual or automatic motor-driven zoom control for perfect video pictures in every shooting situation. Automatic fade-in/fade-out control. Built-in condenser microphone for simultaneous picture and sound recording.

**HVC-2200. Portable Color Camera \$1300.00**

# SONY

Sony Video Communications

# COLOR MONITORS



PVM-5300

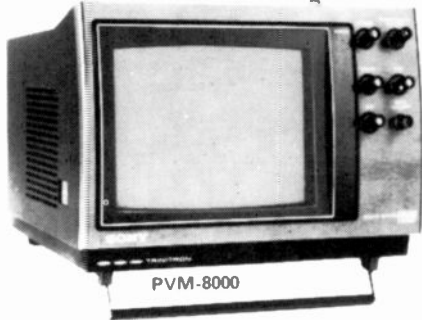

PVM-8000

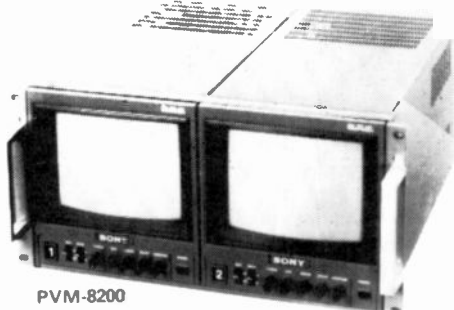

PVM-8200



PVM-1211F



PVM-1850PS



CVM-1250/CVM-1900/CVM-2105

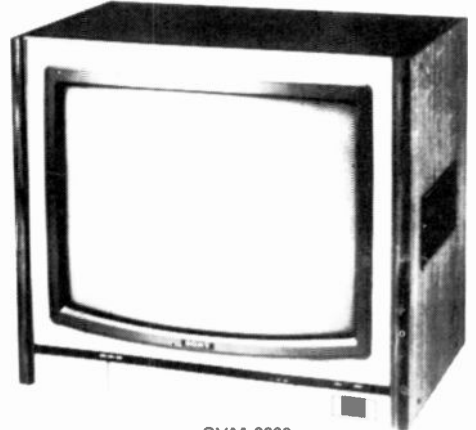

CVM-3000

### PVM-5300 Triple 5" Trinitron Color Monitors

3-gang color video monitor, ideal for camera monitor or preview monitor at video studios. Fits EIA 19" standard rack. Non-composite signal connection is possible with Sync INT/EXT selector switch. Set-up Switch for easy adjustment of white-balance and horizontal static convergence. Loop-through receptacles are provided for video and sync inputs. Weight: 52 lbs. 7 oz. Dimensions: 19" x 7" x 16 1/2"

PVM-5300. Triple 5" Trinitron Color Monitors ..... \$2300.00

### PVM-8000 8" Portable Trinitron Color Monitor

A new professional studio monitor that's able and willing to travel. Automatic/Manual color control. Video and audio IN/OUT for loop through connection. Glare free screen. Optional battery pack (BP-80) and Car Battery Cord for portable operation. Degaussing switch. Ideal for ENG and EFP applications. Weight: 18 lbs. Dimensions: 11 1/2" x 9-5/8" x 14 3/8" (HWD).

PVM-8000. 8" Portable Trinitron Color Monitor ..... \$795.00

### PVM-8200MB Trinitron Dual 8" Color Monitor

Two 8" (measured diagonally) studio monitors in EIA 19" standard rack-mount configuration. Automatic color control to check chrominance level. Design allows each unit to be used separately, and optional rack-mount adaptor accommodates waveform monitor or vectorscope. Dual video signal inputs. INT/EXT selector switch for noncomposite input signals. Loop-through facilities for video and sync bridging to as many monitors as desired. Front-panel tally light on each unit. Weight: 61 lbs. 10 oz. Dimensions: 9-3/8" x 19-1/4" x 21-3/4" (HWD).

PVM-8200MB. Trinitron Dual 8" Color Monitor ..... \$1590.00

### PVM-1211F "Fine Pitch" Trinitron 12" Color Monitor

Fine pitch Trinitron picture tube with 90° deflection delivers 400 TV line resolution. Suitable as a picture monitor at video studios, fits EIA 19" standard rack. Dual video inputs with input signal selector for enhanced studio flexibility. Sync INT/EXT selector switch for noncomposite input signals. Selectable Scanning system. NORMAL/DELAY/NARROW. Interval check is possible in Horizontal, Vertical and Horizontal and Vertical (cross-pulse) at delayed scanning mode. Cross-pulse check is also possible at NARROW scanning mode. White balance adjustment is easy for separate Gain/Bias controls in each Red, Green, Blue. Selectable AUTO, COLOR or MONOCHROME with mode selector switch. Tally Lamp circuitry is incorporated. Loop-through receptacles are provided for video and sync inputs. Weight: 59 lbs. 8 oz. Dimensions: 12-3/8" x 19" x 16-1/4" (HWD).

PVM-1211F. "Fine Pitch" Trinitron 12" Color Monitor ..... \$1550.00

### PVM-1850PS 18" Trinitron Color Monitor

Reproduces video and audio from modified NTSC, PAL and SECAM signals. Video and audio IN/OUT connections for loop-through systems. Weight: 71 lbs. 10 oz. Dimensions: 23-5/8" x 16-7/8" x 15-3/4"

PVM-1850PS. 18" Trinitron Color Monitor ..... \$1500.00

### CVM-1250/CVM-1900/CVM-2150 Trinitron Color Monitor/Receivers

Receives American standard (NTSC color/EIA monochrome). Detent tuning for quick and easy selection of both VHF and UHF channels. Versatile and easy connections with 8-pin connector. UHF BNC-type connectors and mini jacks. Loop-through (LINE OUT) jack is equipped and convenient for multiple monitor connection... up to 5 monitors connectable.

CVM-1250. 12" Color Monitor/Receiver. Weight: 38 lbs. 2 oz. Dimensions: 15" x 19" x 15-5/8" (HWD) ..... \$795.00

CVM-1900. 19" Color Monitor/Receiver. Weight: 65 lbs. Dimensions: 16-7/8" x 23-5/8" x 15-1/8" (HWD) ..... \$1095.00

CVM-2150. 21" Color Monitor/Receiver. Weight: 90 lbs. 6 oz. Dimensions: 19-3/4" x 26-7/8" x 15-5/8" (HWD) ..... \$1560.00

### CVM-3000 30" Color Trinitron Large-Screen Color Monitor/Receiver

The Sony CVM-3000 color monitor/receiver offers the world's largest screen combined with the world's most acclaimed color system to provide an entirely new dimension in studio viewing.

The picture you see on the 30" diagonal screen is studio-accurate, with rich, life-like color. The newly designed Trinitron picture tube uses a velocity modulation system, 114 degree deflection, comb filter Y/C separation, and 10 different automatic control circuits to deliver the finest picture ever achieved on a large screen television. More accurate, more reliable station tuning featuring automatic station memory. A remote commander (RM-503) controls power, volume or mute, station selection, and other functions. The set has a 3-way LED function indicator to monitor operation in PROGRAM, STAND-BY or REMOTE modes. Dimensions: 33-7/8" x 29-3/8" x 22-7/8" (WHD). Net Weight: Approx. 275 lbs. 9 oz.

CVM-3000. 30" Color Trinitron Large Screen Color Monitor/Receiver ..... \$7800.00

VMC-1H	8-pin female coupler	\$11.00
VMC-1M	10-pin to 8-pin monitor cable	33.00
VMC-3P	8-pin video extension cable 10'	22.00
VMC-10P	8-pin video extension cable 32'	44.00
VMC-25P	8-pin video extension cable 82'	71.00
VMC-1MQ	Octopus cable for dubbing	35.00

# SONY

Sony Video Communications

## MONITORS/RECEIVERS

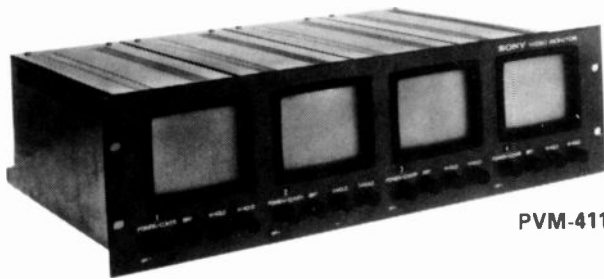

PVM-411



PVM-1900

CKV-1900F



### PVM-1900 19" COLOR VIDEO MONITOR

#### FEATURES

- Reproduces the playback picture and sound from a VTR and monitors picture from a video camera • External sync can be acceptable
- Dual inputs for both video and audio (LINE A or LINE B selectable)
- Normal or narrow scanning is selectable

#### SPECIFICATIONS

**Video signal system:** EIA 525 lines, 60 fields

**Color system:** NTSC color

**Picture tube:** Trinitron, 50cm (20"), visible picture size 47.3cm (19"), measured diagonally, 100-degree deflection

**Video input (LINE A and B, VTR IN):** Composite; 1.0Vp-p + /-6 dB, sync negative, 75 ohms, unbalanced. Non-composite; 0.7Vp-p, positive, 75 ohms, unbalanced

**External sync input:** Composite sync, 4Vp-p + /-6 dB, negative

**Audio input (LINE A and B, VTR IN):** -5 dB, high impedance

**Video output (LINE A and B):** Loop-through with 75-ohm terminator

**Audio output:** Loop-through

**Audio power output:** 2W (max.)

**External sync output:** Loop-through with 75-ohm terminator

**Scanning system:** Normal/narrow selectable

**Connectors:** BNC for video and sync. Mini for audio, 8-pin for video/audio

**Power requirements:** AC 120V, 50/60Hz

**Power consumption:** 130W

**Dimensions:** 518(W) x 506(H) x 473mm(D) (20-1/2 x 20 x 18-5/8")

**Weight:** 31 kg (68 lb 5 oz)

**Supplied accessory:** Monitor connecting cable with 8-pin connectors

945.00

### CKV-1900F 19" COLOR TV RECEIVER

The CKV-1900F is a color TV receiver equipped with an independent F-type VTR-IN connector for viewing the playback picture from the RF/VHF output of the VTR. It has the same innovative exterior design as the CVM-1900 Receiver/Monitor and the PVM-1900 Video Monitor, and is appropriate for any economical video system for either professional or institutional use.

#### FEATURES

- Receives American TV standard VHF and UHF TV channels • Synthesizer tuner (VHF/UHF) with automatic station memory that holds up to 14 active channels • Reproduces picture and sound from RF/VHF output of the VTR • Independent VTR-IN connector (F-type)
- VTR/TV selection switch • LED digital channel display • Sub volume control provides initial sound level • Soft-touch front panel controls for secondary volume adjustments • Side panel mounts for safety chain • Cabinet is identical to CVM-1900 receiver/monitor and PVM-1900 video monitor

#### SPECIFICATIONS

**Television system:** American TV standards

**Color system:** NTSC

**Picture tube:** Trinitron, 50cm (20"), visible picture size 47.3cm (19"), measured diagonally, 100-degree deflection

**Channel coverage:** VHF Channels 2-13 UHF Channels 14-83 Up to 14 preselected channels

**Input:** VTR-IN (F-type)

**Audio power output:** 2W (max.)

**Speaker:** 7 x 12cm, oval

**Power requirements:** 120V AC, 50/60 Hz

**Power consumption:** 125W (max.)

**Dimensions:** 20" x 20-1/2" x 18-5/8" (HWD) 506mm x 518mm x 473mm (HWD)

**Weight:** 61 lbs. 12 oz. (28kg)

**Supplied accessories:** Instruction manual, Earphone, F-Type connector, Antenna connector (300-75 Ohms matching transformer is built in)

649.00

### PVM-411 Quadruple 4" Monochrome Monitor \$1275.00

- Four independently controlled 4" screen (measured diagonally) monochrome monitors in a single rackmount unit • Fits EIA standard 19" rack • Individual unit shielding minimizes magnetic crosstalk distortion • Spot-killer circuitry prevents phosphor burns when bright images remain on-screen for extended periods • Loop-through capability enhances use in multiple location production and surveillance applications • Individual front-mounted contrast, brightness, V-hold and H-hold controls • Weight: 35 lbs. 4 oz. • Dimensions: 5 1/4" x 19" x 12 1/2" (HWD)

# SONY

Sony Video Communications

## VIDEO TAPE

VIDEO TAPE 3/4" U-MATIC	Playing Time Minutes	Tapes Per Carton	Price
KCS-10	10	12	\$20.50
KCS-20	20	12	25.00
KCA-30	30	12	28.00
KCA-60	60	12	35.00
KCS-10BR	10	12	21.55
KCS-20BR	20	12	26.45
KCA-30BR	30	12	29.80
KCA-60BR	60	12	37.50

### 1/2" BETAMAX

	B I	B II	B III		
L-125	15	30	45	12	\$11.25
L-250	30	60	90	12	12.45
L-500	60	120	180	12	16.95
L-750	90	180	270	12	21.35
L-830	N/A	200	300	12	24.60

Model	Reel Diameter	Playing Time Minutes	Tapes Per Carton	Price
<b>1/2" REEL-TO-REEL</b>				
V-30H	5-1/8"	30	12	\$22.50
V-32	7"	60	12	37.50
V-35	5"	20	48	17.00

### 1/2" HIGH ENERGY TAPE

V-71	7"	30	12	\$30.00
V-72	7"	60	12	44.00

### 1/2" ENDLESS LOOP CARTRIDGES

LV-5	—	5	12	\$20.00
LV-10	—	10	12	25.00

### 1" TAPE

V-12-30A	8"	30	10	50.00
V-12-60A	8"	60	10	70.00
V-16-34B	9" NAB	34	5	75.00
V-16-64B	9" NAB	64	5	115.00
V-16-96B	10.5" NAB	96	5	170.00

### TAPE ACCESSORIES

KA-1	Cassette adaptor — KCS to KCA	\$ 4.00
KCS-1C	1/4" cleaning cassette (small)	20.00
LC-11	3/4" cassette mailing case	4.95
RH-5E	1/2" empty reel 5-1/8" diameter for V-30H	4.50
RH-7V	1/2" empty reel 7" diameter for V-32	5.00
VSK-35	1/2" splicing kit for V-35	45.50

\* For use with Beta format videocassette recorders having B III recording and/or playback mode.

## SONY V16 SERIES 1" HIGH-BAND MASTER VIDEOTAPE



Sony in one of the world's largest magnetic tape production plants under the most rigid quality control standards.

V-16 Series videotape combines excellent picture and sound quality with the economy and convenience of the 1" tape format. Wide frequency range, high signal-to-noise ratio, minimum dropouts, and precision winding make V-16 Series videotape perform superbly in even the most demanding studio and field applications.

Sony Broadcast V-16 Series videotape is available in both 64-minute and 96-minute lengths. Reel after reel, it delivers the consistent quality and reliability that has helped make 1" recording today's most exciting new development in broadcast technology.

# SONY

Sony Video Communications

## COLOR CAMERAS

### DXC-1640 Portable MF Tricon® Color Camera

- 2/3" MF Tricon System yields excellent uniformity and colorimetry, with horizontal resolution of more than 300 lines and S/N ratio better than 45 dB
- Compact size and light weight (less than 10 pounds, including the lens) make operation easier, more comfortable
- New, especially fast 6:1 macro/zoom lens (f1.4; 11-70mm) permits zooming and focusing with one hand; macro focus for dramatic close-ups; and auto-iris control for correct exposure even with quick ambient light changes
- Internal controls prevent blanking width widening and editing difficulties
- Low power consumption (11 watts) and up to 150 minutes of operation with optional BP-60 battery pack
- Five way power supply allowing operation from: portable videocassette recorder, a battery pack (BP-60), an AC adaptor (CMA-5), a camera control adaptor (CMA-6) or a car battery adaptor (DCC-3000)
- 1.5" electronic viewfinder allows monitoring video recording and playback while on location
- Built-in color temperature filter permits optimum color balance under all lighting conditions
- White balance control—white balance can be accurately set using a built-in meter
- Automatic Gain Control plus manual video level controls for increased flexibility
- Portable videocassette recorder start and stop functions may be controlled directly from the DXC-1640
- External sync facility—optional CMA-1640
- External sync facility—optional CMA-6 camera control unit provides external sync facility and remote camera control functions.

Weight: 9 lbs. 15 oz.

Dimensions: 9-1/2" x 4-1/16" x 11-1/2" (HWD)

DXC-1640 ..... \$1995.00



DXC-1640

### DXC-1850 HBST Color Video Camera

- 2/3" HBST (High Band Saticon™ Tricon) pickup tube for the best possible picture from a single-tube color video camera
- HBST pickup tube assures high resolution, good color fidelity and uniformity, low image lag and retention
- Lightweight camera head (less than 1 lb. 9 oz.) for precision interface with optical equipment: microscopes used in medicine, biology, metallurgy
- Full range of automatic controls for very simple, very safe operation
- Ideal for surveillance and teleconferencing, especially when lighting and installation-space are limited
- 3-mode white balance: automatic, manual and halogen-lamp
- Red Hue Expander, Red Detail Control for enhancing and delineating red color nuances
- Provision for handle on control unit, which is 19" EIA Standard for rack mounting
- Safety conscious features include an exterior finish highly resistant to alcohol and disinfectants, electrical leakage of less than 10 micro Amps and solid housings not prone to damage from accidental spills
- On-screen illumination indicating lines simplify illumination adjustments
- Uniformity control ensures optimum color quality with wide variety of optical instruments by compensating for color hue distortions
- Built-in two line type Vertical Image Enhancer
- Automatic Beam Optimizer — ABO
- VBS GenLock capability
- Automatic and manual gain/iris control
- Chroma level control

#### Supplied Accessories

- Camera cable (10m)
- 75 Ohm coaxial cable with BNC connector (10m)
- AC power cord
- Camera head bracket
- Bracket set for 19" rack mounting
- Filter set (ND4, W14 and replacement tool)
- Battery (Eveready M 542)

#### Optional Accessories

- VCL-1106YB 6.1 auto iris power zoom lens
- VCL-08S Wide angle lens
- CCJ-10 10m camera cable
- CCJ-25 25m camera cable
- CCJ-50 50m camera cable
- MVA-11 Microscope adaptor
- MVA-102 Endoscope adaptor

DXC-1850 Color Video Camera ..... \$8500.00



DXC-1850





DXC-1800

### DXC-1800 Portable Color Camera

- **Full system capability.** The DXC-1800 camera is the center of a complete shooting system, including two viewfinders, CCU, cable controls, special lenses and adapters. With the rack adapter accessory, CCU, 4" monitor and AC adapter can all be mounted in a single standard 19" rack. The system can easily be configured for either ENG or studio use.
- **New pick-up tube.** A Se-As-Te (Saticon® type) photoconductive target is combined with a laminar flow electron gun and a built-in bias lamp to provide a sharper picture with reduced lag and improved sensitivity.
- **Built-in microprocessor.** The DXC-1800 features microprocessors built into both the camera and CCU. These computers control the advanced automatic functions and monitor the functioning of the system using serial data transmission.
- **Excellent picture quality.** The unit produces 300 lines horizontal resolution with better than 48 dB signal to noise ratio. Vertical and horizontal picture enhancement make the picture sharp and clear.
- **Easy portability.** The camera weighs just 6 lbs., 13 oz., without lens or shoulder brace. The strong, lightweight aluminum die-cast frame provides excellent shielding and protection from elements. The standard viewfinder and the shoulder brace are easily reversed for use by left-handed operators. 11.6 watt power consumption (exclusive of viewfinder and power lens) allows long battery life in the field.
- **Full warning system.** The operator is provided with indicators for record, insufficient light, battery, tape end, moisture, tape slack and servo, which greatly reduces the possibility of recording errors.
- **Other extras.** The camera incorporates VBS gen lock, a built-in color temperature filter and color bar generator, horizontal and vertical blanking width control, and a built-in microphone with connections for an external microphone. An audio monitor jack, tally light and intercom are incorporated in the studio viewfinder (DXF-40).

All of these accomplishments are especially outstanding in a portable camera that weighs only 6 pounds, 13 ounces, exclusive of lens and shoulder brace, and which consumes just 11 watts of power.

Full system capability, including the availability of camera control unit, a variety of zoom lenses, and two different viewfinders (1.5" DXF-3; 4" DXF-40), make the DXC-1800 one of the most versatile cameras ever presented. Both the standard 1.5" viewfinder and the hand-grip/shoulder brace may be reversed for easier, more comfortable use by left-handed operators.

### SPECIFICATIONS

- **Video output:** 1.0Vp-p, sync negative, 75 ohm • **S/N ratio:** 48 dB (luminance) Isig = 0.15 micro amp, band width 4 MHz, measured at pre-amp out • **Viewfinder:** 1.5" electronic viewfinder DXF-3 or 4" electronic viewfinder DXF-40 • **Lens:** VCL-1106 YB F1.4 6:1 (11-70mm) powered zoom, 3 modes of iris control (auto/manual/auto-lock), macro • **White balance control range:** more than +/- 500°K • **Power requirements:** DC 12V • **Operating temperature:** 32°F 104°F (0°C 40°C)

### DXC-1800K

DXC-1800 Camera Head • VCL-1106YB 6:1 Power Zoom Lens • DXF-3 1.5" Electronic Viewfinder • DC-6 Battery Case • VCT-8 Shoulder Brace • LC-1800 Carrying Case • CCQ-2AR 14-pin Cable-6' • CCQJ 14-pin to 10-pin Cable-6' **\$2795.00**

### DXC-1800L

Same as DXC-1800K But without Lens. **\$2695.00**

### DXC-1800H

DXC-1800 Camera Head and CCQ 2AR Cable Only. **\$2345.00**

### DSC-1800 Studio

DXC-1800 Camera Head • CCQ-2AR 14-pin Cable-6' • CCU-1800 Camera Control Unit • DXF-40 4" Electronic Viewfinder • CMA-7 AC Adaptor • RMM-1800 Rack Mount Bracket for Viewfinder, AC Adaptor and Camera Control Unit

All Lenses and CCQ-5AR, 10AR, 25AR and 50AR Camera Cables Are Optional. **\$3645.00**

### Optional Accessories —

CCU-1800	Camera Control Unit	<b>\$895.00</b>
DXF-40	Viewfinder	<b>425.00</b>
DXF-3	Viewfinder	<b>320.00</b>
CMA-7	AC Adaptor	<b>360.00</b>
RMM-1800	Rack-Mounting Metal	<b>120.00</b>
CCQ-10AR	Camera Cable	<b>150.00</b>
CCQ-25AR	Camera Cable	<b>275.00</b>
CCQ-50AR	Camera Cable	<b>525.00</b>
CCQJ-2 (2m)	Camera Cable	<b>50.00</b>
LO-21	Flexible Cable Unit	<b>495.00</b>
LO-22	Flexible Cable Unit	<b>495.00</b>
VCR-16D	Film Camera Attachment	<b>577.00</b>
MVA-1B	Microscope Attachment	<b>673.00</b>
MVA-11	Microscope Adaptor	<b>535.00</b>
MVA-102	Endoscope Adaptor	<b>To Be Announced</b>
SEG-1210	Special Effects Generator	<b>6950.00</b>
MD-1200	Multi-signal Distributors	<b>To Be Announced</b>
MD-1210	Multi-signal Distributors	<b>To Be Announced</b>
MD-1600	Multi-signal Distributors	<b>3500.00</b>
BC-1000	Battery Charger	<b>495.00</b>
BC-20	Battery Charger	<b>170.00</b>
BP-60	Battery Pack	<b>60.00</b>
DCC-3000	Car Battery Adaptor	<b>357.00</b>
ECM-31HVC	Unidirectional Microphone	<b>50.00</b>

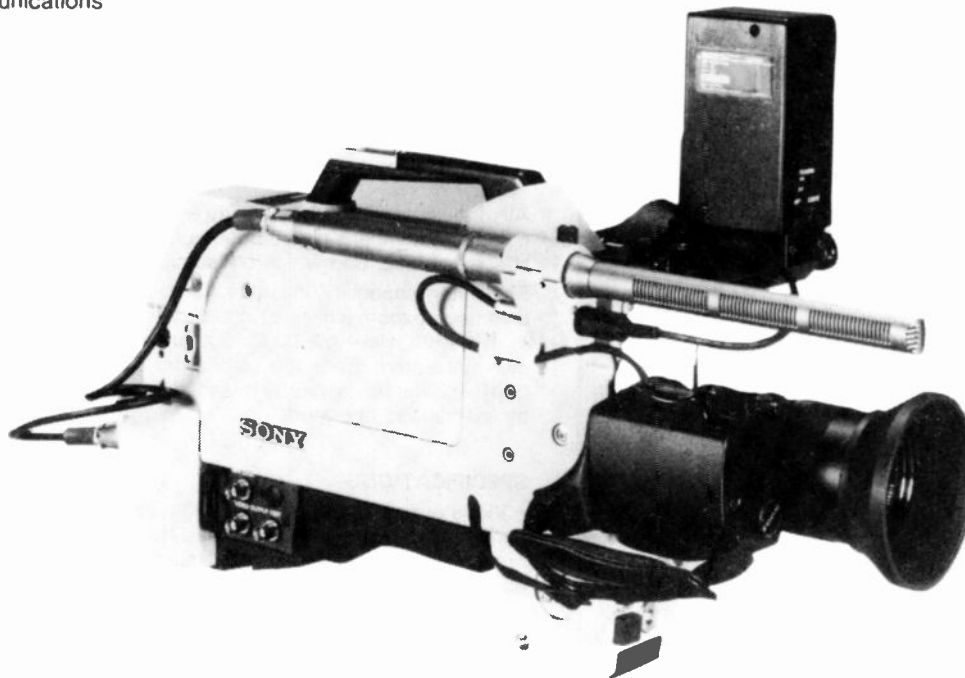

DXC-6000

**DXC-6000**  
**Portable Color Camera**

**3-tube prism optics system.** F1.4 prism optics and three pickup tubes combine for outstanding performance, with sensitivity, resolution, colorimetry and picture stability that make the camera excellent for use either in the studio or in the field.

**Low light level operation.** A low-noise pre-amplifier and a +9/ +18 dB gain adjustment switch enable shooting with as little as 40 lux (4 foot-candles) illumination.

**Easy portability.** The camera unit itself weighs just 12.4 pounds, is well-balanced, has a full warning system, and uses only 22 watts. The durable housing also protects the camera from the elements.

**Precision results.** Signal to noise ratio is better than 53 dB, and the vertical image is enhanced by 1 line with standard circuitry or by 2 lines as an option, to produce a picture with exceptional clarity.

**Full automatic controls.** Control systems include automatic beam optimizer, auto iris, and auto digital black and white balance with automatic lens closing and a memory to preserve black and white balance from one setup to the next even when the power is shut off.

**Built-in microprocessor.** Microprocessors are built into the camera head and CCU for control of the advanced automatic functions. The camera head and CCU communicate by serial data transmission which reduces the number of conductors necessary in the camera cable. The camera head contains a memory to remember setup information even when the power is interrupted.

**Full system versatility.** The camera has a variety of accessories and peripheral equipment to make it adaptable to virtually any video situation. There are a variety of zoom lenses and other optical adaptors, camera control units, many operating aids and the full line of Sony recorders and monitors.

The new Sony DXC-6000 is a professional quality camera that is small, light and versatile enough for field production anywhere. The camera, exclusive of lens and viewfinder, weighs only 12.4 pounds, and has a rugged, weatherproof housing. Inside, three 3/8" mag-mag Saticon® tubes and a low noise preamplifier combine with an f1.4 prism optics system to produce high sensitivity, fine resolution, crisp colorimetry and remarkable picture stability. Excellent results are achieved even at low light levels with help from the +9 dB/+18 dB gain switch. The built-in microprocessor controls many automatic functions and monitors the system operation. It even remembers previous setup information when the power is interrupted, all of which makes for simple operation of a very advanced camera system. Signal to noise ratio is better than 53 decibels, and the vertical image is enhanced — offering you a picture with outstanding clarity.

Important for field operation, the camera is easily held and operated. The optical axis is low, and this low center of gravity makes operating comfortable. A full warning system alerts the operator to conditions which affect or inhibit shooting. And the variety of other system components and accessories, from camera control unit to microscope adaptor, insure that the camera will deliver professional results in any situation, whether in the studio or in the field.

**Pickup Tube:** Three 3/8" Mg-Mg Saticon® .

**Optical System:** F1.4 prism.

**Synchronization:** Int. Ext. (VBS/BB Gen-lock).

**Lens Mount:** Bayonet.

**Color Temp. Filter:** Close/3200°K/5600°K +1/4N D/5600°K.

**Horizontal Resolution:** 500 TV line at center.

**Sensitivity:** 2000 Lux F4 (typical) 3200°K, 89.9° reflectance.

**S/N Ratio:** More than 53dB luminance I sig (G) = 0.2uA 4.2MHz.

**Power Consumption:** 22W (DC12V).

**Power Requirement:** DC10-17V, 12V standard.

**Registration:** Less than 0.1% Zone I. Less than 0.4% zone II. Less than 0.8% Zone III.

**Geometric Distortion:** Less than 2%.

**Weight:** 12 lb. 6 oz. w/o lens.

**Ambient Temperature:** -20°C to 40°C (-4°F to 104°F).

**Controls:** Digital auto white/black balance switch; VTR record start switch; return video switch; gain switch (0dB, +9dB, +18dB); camera/color bar switch; standby switch; registration adjustment switch; (R-G, B-G, R, G, B); R/B H. Cent.; R/B V. Cent.; master pedestal; video select switch (reg./NTSC); power switch; VF brightness; VF contrast; VF peaking on/off.

DXC-6000L including DXF-3, DC-6, VCT-300, LC-6000, CCA-2AR . . . . . \$14,900.00

**6000 Option Prices**

Fujinon A12X9BRM-58 Zoom Lens . . . . .	\$3500.00
Fujinon A12X9BERM-58 Zoom Lens . . . . .	4200.00
Fujinon A14X9.5BERM-28 Zoom Lens . . . . .	5050.00
RMS-5 Rear Lens Control Kit . . . . .	954.00
CCU-6000 Camera Control Unit . . . . .	3750.00
RMM-301 19" Rackmount Adapter . . . . .	150.00
CCX-10A Camera Cable — 32' . . . . .	400.00
CCX-25A Camera Cable — 82' . . . . .	600.00
CCX-50A Camera Cable — 165' . . . . .	900.00
CCX-100A Camera Cable — 330' . . . . .	1500.00
CMA-7 AC Supply . . . . .	360.00
DXF-3 1.5" Viewfinder . . . . .	320.00
DXF-40 4" Viewfinder . . . . .	425.00
RMS-5 . . . . .	954.00

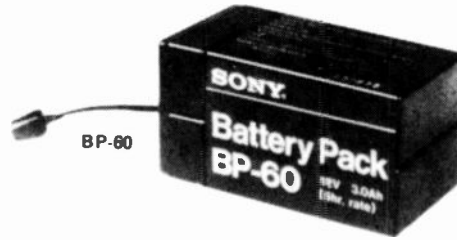

## AC ADAPTORS AND BATTERIES

Model	Description	Price
AC-340A	AC adaptor for SLO-340, SVM-1010 charges BP-20A, BP-60	\$300.00
AC-3400	AC adaptor for AV-3400	156.00
BC-20	Dual battery charger for BP-20, BP-20A and BP-60	170.00
BP-30	Long-Life battery pack for AV-3400	142.00
BP-20A	Rechargeable battery pack (12V DC) for DXC-1600	63.00
BP-60	Rechargeable battery pack (12V DC) for DXC-1610, DXC-1640, SLO-340 and VO-4800	68.00
BC-1000	Battery charger — will charge up to 6BP-20A or BP-60 batteries simultaneously	495.00
CMA-5	AC adaptor for DXC-1610, DXC-1640	192.00
CMA-7	AC adaptor for DXC-1800	360.00
DC-5	BP-60 battery adaptor case for the DXC-1640	130.00
DC-6	Battery adaptor case for DXC-1800	68.00
DCC-2400	Car battery cord for AV-3400	25.50
DCC-3000	Car battery adaptor for VO-4800/DXC-1610, DXC-1640 and AV-3400/AVC-3450. Use only with negative-ground cars	357.00
HVA-200	AC adaptor for HVC-2000	52.00

## MONITOR ACCESSORIES

Model	Description	Price
MB-500	19" rack mount for PVM-8200	\$120.00
MB-501	Mount attachment for PVM-8200	55.00
RFC-25	RF cable 82'	50.00
VLC-51	Carrying case for PVM-8000	210.00

## VTR ACCESSORIES

Model	Description	Price
DT-30	Digital timer for SLO-260, SLO-323	\$ 20.00
LC-320	Carrying case for SLP-303 or SLO-323	85.00
LC-340	Carrying case for SLO-340	80.00
LC-3400A	Carrying case for AV-3400 and AVC-3450	105.00
RFK-534	Switchable CH3/CH4 RF modulator for VP-2010, VP-2011, VO-2610, VO-2611 and 300 series Betamax models	100.00
RFU-63FW	B/W RF modulator Channel 3 for AV-3400, AV-3600, AV-3650	115.00

RFU-64FW	B/W RF modulator Channel 4 for AV-3400, AV-3600, AV-3650	115.00
RM-300	Remote Random Access control unit for SLP-300, SLP-303, SLO-320, SLO-323, VP-2011 and VO-2611	200.00
RM-400	Automatic editing control unit	580.00
RM-410	Remote control for VO-2860A, VO-2800	313.00
RM-420	Remote control for VP-2011, VO-2610, SLP-300, SLP-303, SLO-320 and SLO-323	137.00
RM-440	Automatic editing control unit for VO-2860A, VP-2260 and SLO-383 w/BIDIREX	1770.00
RM-444	Master Remote Control unit for both U-Matic or Betamax recorders in multiple duplication systems	1250.00
RMM-8	Rack mount for RM-444	40.00
RX-303	Automatic Search Control for SLP-300, SLP-303, SLO-320, SLO-323, VP-2011, VO-2611. 63 segment capacity, programmed playback of 8 segments. Remote control capability including rewind/stop/play/fast forward/pause	350.00
RX-353	Programmable auto search control for SLO-320, SLO-323, VO-2611. Same features as RX-303 plus segment coding, timer operation, cue function	400.00
TT-300	Tuner/Timer for VO-2610, SLO-323	395.00

## CABLES

Model	Description	Price
CCDQ-06	14 pin to 4 pin cable, 2'. DC power cord for CCU-1800 from CMA-7	\$ 22.00
CCDD-2.5	Tally cable 2.5 meters, 4 pin	11.00
CCDY-2.5Y	18 pin CCY to 4 pin 2.5 meter tally cable for MD-1200 w/ DXC-1800, DXC-1640	35.00
CCF-5	6 pin camera extension cable. 16 ft. (5m)	21.50
CCF-10	6-pin camera extension cable. 32 ft. (10m)	32.50
CCJ-1	10-pin video/audio extension cable. 5 ft. (1.6m)	47.00
CCJ-5	10-pin video/audio extension cable. 16 ft. (5m)	65.00
CCJ-10	10-pin video/audio extension cable. 32 ft. (10m)	88.00
CCQ-2AR	14 pin extension cable for VO-4800/DXC-1640/DXC-1800 6'	80.00
CCQ-5AR	14 pin extension cable for VO-4800/DXC-1640/DXC-1800 16'	100.00

CCQ-19AR	14 pin extension cable for VO-4800/DXC-1640/DXC-1800 33'	150.00
CCQ-25AR	14 pin extension cable for VO-4800/DXC-1640/DXC-1800 82'	275.00
CCQ-50AR	14 pin extension cable for VO-4800/DXC-1640/DXC-1800 165'	525.00
CCQJ 2	14 pin to 10 pin cable 6'	50.00
CCJQ 0.5	10 pin to 14 pin cable 1.6'	52.00
CCX-10A	26 pin extension for DXC/CCU-6000, 32' (10m)	400.00
CCX-25A	26 pin extension cable for DXC/CCU-6000, 82' (25m)	600.00
CCX-50A	26 pin extension cable for DXC/CCU-6000, 165' (50m)	900.00
CCX-100A	26 pin extension cable for DXC/CCU-6000, 330' (100m)	1500.00
CCY-10	18 pin camera extension cable for DXC-1210 with JB-6A junction box, 32 ft.	247.00
CCY-25	18 pin camera extension cable for DXC-1210 with JB-6A junction box, 82 ft.	434.00
CMC-1	Video monitor cable with 8 pin connector and mini-plug for VCS-31	10.00

## VTR CABLES

RCC-5C	16' (5m) Remote control cable for RM-410 and RM-420	\$105.00
RCC-5E	16' (5m) Remote control cable for RM-440	110.00
SGC-5	BNC-UHF coaxial cable, 15'	13.00
UGC-2	Coaxial cable w/BNC connectors, 5'	10.00
UGC-5	Coaxial cable w/BNC connectors, 15'	13.00
UGC-8	Coaxial cable w/BNC connectors, 25'	15.00
VDC-5	Video dubbing cable for VO-2860A and SLO-383	50.00

## MONITOR CABLES

VMC-1H	8-pin female connector to connect 8-pin male connectors of two cables	11.00
VMC-1M	Monitor connecting cable with 8-pin and 10-pin connectors	33.00
VMC-3P	8-pin video extension cable, 10 ft.	22.00
VMC-10P	8-pin video extension cable, 32 ft.	44.00
VMC-25-P	8-pin video extension cable, 82 ft.	71.00
VMC-1MQ	Octopus cable for dubbing, 14-pin to 8-pin	35.00

## MICROPHONE CABLES

EC-5M/10M/25M	Microphone Extension cable, 16'/32'/82'	7.15 8.60 17.00
---------------	---	-----------------------

# SONY

Sony Video Communications

## MICROPHONES

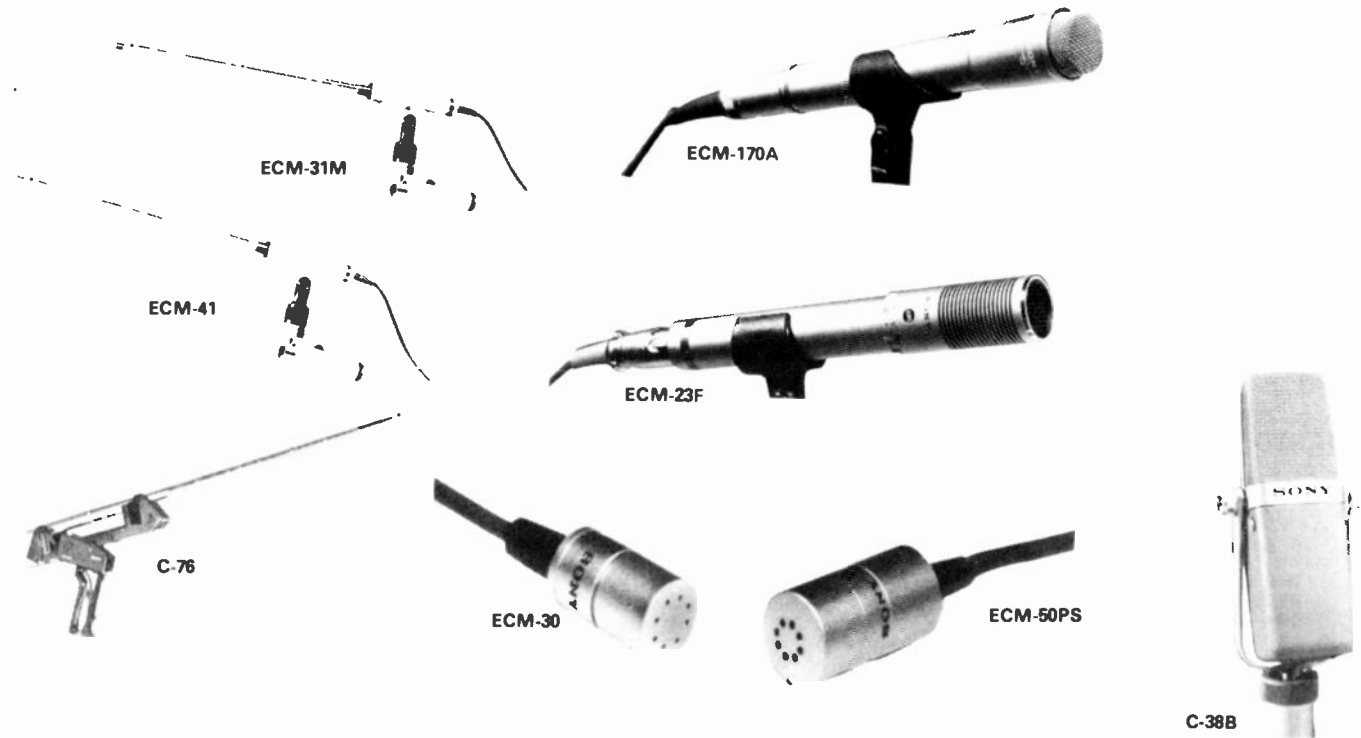

### Uni-directional Electret Condenser Microphone for Newsgathering and Interviews

**ECM-31M.** The new Sony ECM-31M is the ideal microphone for indoor and outdoor interviews. The electret microphone head is at the end of a wand which telescopes from the comfortable grip, which also serves as a battery compartment. The length of the microphone may be adjusted according to the height and convenience of the interviewer. A windscreen is supplied for stable performance outdoors. **\$55.00**

### Uni-directional Electret Condenser Microphone for Studio Interviews

**ECM-41.** The Sony ECM-41 makes studio interviews easier than ever before. It is similar in appearance to the ECM-31 microphone for newsgathering and interviews, but incorporates professional features such as balance line—giving you added reliability and control inside the studio. The electret condenser microphone is at the end of a wand which telescopes from the comfortable grip. The wand may be adjusted according to the height and convenience of the interviewer. A windscreen is provided to help prevent "pops" and wind noise. **\$100.00**

### Super Uni-directional, Gun-type Electret Condenser Microphones for Theatrical and Media Use

**C-76.** These Sony professional microphones are considered the standard of excellence around the world for use in theaters, on sound stages, in large halls, in television studios and even outdoors. Extremely fine uni-directional characteristics make them the perfect microphones to use where proximity is unwanted or impossible: the microphone is simply aimed at the sound source to achieve fine results. The quality performance of the C-76 is ideally suited to the performing arts. High sensitivity with broad frequency response and excellent transient capability bring out the best in any performance...even from a distance. The microphones discriminate against background noise and unwanted sounds—cutting through to the source. **\$795.00**  
**C-74 Short Shotgun Condenser Mic** **675.00**

### Omni-directional Electret Condenser Microphone w/Flat Frequency Response

**ECM-170A.** The Sony ECM-170A features a low-cut switch for better voice articulation. Flat frequency response, detachable windscreen, and rugged construction increase the versatility and performance of this economical microphone making it ideally suited for EFP as well as studio applications. **\$75.00**

### Professional Omni-directional Condenser Microphone w/Ultra-miniature Design

**ECM-30.** One of the smallest condenser microphone in existence, the new Sony ECM-30 is our most recent addition to a family of tie-tack and lapel microphones already in use by television broadcasting studios around the world. The Sony ECM-30's extremely small size is made possible by uniting the backplate and FET amplifier pellet in the microphone capsule, an extraordinary achievement of Sony engineers. **\$115.00**

### Uni-directional Back Electret Condenser Microphone for Battery Powered Use

**ECM-23F.** Operating for the extremely long period of more than 6,500 hours with one size "AA" battery, the ECM-23F is a high-quality, high-performance microphone suited to use in industrial television and broadcast studios. **\$115.00**

### Professional Omni-directional Electret Condenser Microphone w/Miniature Design

**ECM-50PS.** The most commonly seen tie-tack microphone on television today, the Sony ECM-50PS is a unique product of Sony's combined expertise in both microphone and semi-conductor technology. Its extremely small size and omni-directional characteristics make the ECM-50PS perfectly suited to use in ENG and TV production, in personal interview situations, and by other professional audio technicians in a wide variety of applications. **\$225.00**  
**AC-148F Phantom Power Supply** **\$220.00**

### Professional Condenser Microphone w/Switchable Omni-directional or Uni-directional Characteristics Internal Battery or Phantom Power

**C-38B.** An excellent all-purpose microphone for professional use in broadcast or recording studios, theater stage sound systems, wherever circumstances demand a combination of good performance, versatility of operational mode, and simplicity of microphone setup. The Sony C-38B converts instantly from omni-directional to uni-directional characteristics. An improved amplifier gives the C-38B a dynamic range of greater than 116dB, with flat frequency response and sharp directional characteristics in both uni-directional and omni-directional modes. And phantom power capability is another great advantage of the C-38B, making it compatible with other phantom powered studio microphones. **\$545.00**

### MX-20

A fully Professional 8-channel microphone mixer for creating high quality studio or sophisticated amateur recordings. Professional sound engineers and audiophiles alike will appreciate the many performance features of the Sony MX-20. With 8 channel inputs and 4 channel outputs, the MX-20 can mix and switch any input to any one of the four outputs automatically. In addition, there are "PAN POT" and "DEAD CENTER" functions. FET preamplifier insures low-distortion, low-noise signal. Other special features:

**3-position MIC Input Attenuator.** To eliminate overload distortion.

**Balanced MIC Input and Output with XLR Type Connectors.**

**Cascade Connector.** For coupling two MX-20's to produce a 16-channel input mixer.

**5-step EQ Control.** In channels 1-6.

**Slide Master Fader.** For simultaneous control of all channel output and professional recording techniques such as fade-in and fade-out.

**Slanted Front Panel.** With convenient carrying handle.

**Four VU Meters.**

**Abundant Output Level.**

\$1275.00



MX-20



MX-510

### MX-510

With 5 channel inputs and 2 channel outputs, the Sony MX-510 is an economical microphone mixer for both audiophiles and sophisticated amateur recording enthusiasts. Two-way power source allows operation on internal batteries or AC current (an optional adaptor). Five MIC inputs (channels 1-5) for low impedance mics; three line inputs (channels 1, 2, 5) for tape recorder, tuner, or amplifier; two phono inputs (channels 3, 4) for record player. Other features:

**PAN POT Control.**

**Pre-set indicators.** To use as reference point when temporary level changes are necessary.

**External Power Input.**

**Slide Master Fader.** For fade-in, fade-out techniques.

\$225.00

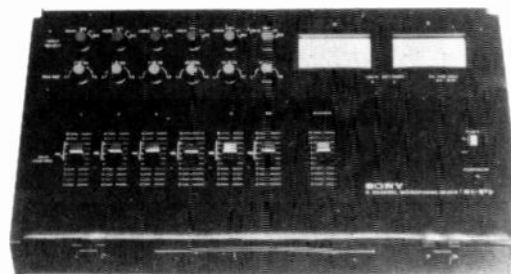

MX-670

### MX-670

The MX-670 portable microphone mixer provides 6 inputs for multi-mic stereo recording, with panning available on each input. Battery or AC operation. (AC-12M adaptor optional.) Allows usage on location or at home.

**Panning.** Provides flexibility in the stereo mix.

**PAD.** Prevents input stage overload.

**Cascade Input.** Accesses the output buss for effects or additional mic inputs with another mixer.

**Oscillator.** 440 Hz. Calibration tone.

**Phono Pre-amp.** Accommodates a stereo turntable.

\$425.00

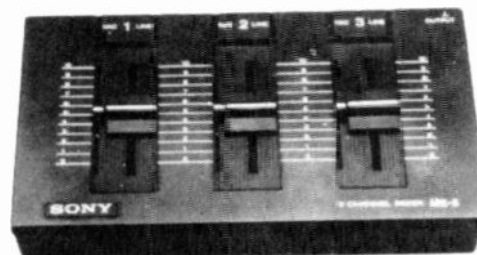

MX-5

### MX-5

The new Sony MX-5 is an economical passive microphone mixer with three channel inputs and one channel output, for combining multiple audio pickups on a single monaural track.

**Special features of the MX-5:**

**Pre-set Indicators.** To use as reference point when temporary level changes are required.

**Line Input.** For connecting tape recorder, tuner, or amplifier.

### MX-7

This new passive microphone mixer from Sony provides six channel inputs and two channel outputs, for mixing up to three microphone or line inputs on each of two stereo output tracks.

**Special features of the MX-7:**

**Pre-set Indicators.** To use as reference point when temporary level changes are necessary.

**Automatic Input Selector.** Mic inputs may be advanced at any time.

**Line Input.** For connecting tape recorder, tuner, or amplifier.

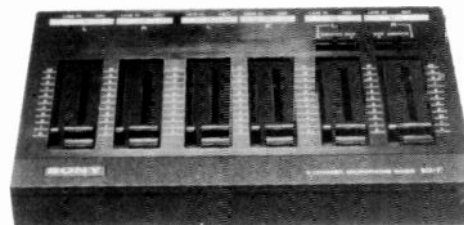

MX-7



PBR-330N

## AUDIO ACCESSORIES

### PBR-330N

Parabolic Sound Reflector — to focus sound waves directly to microphone.

\$70.00



### Profeel® Trinitron® Component Televisions with 25" Measured Diagonally

- Trinitron Color System: Sony's Emmy-Award-winning achievement in picture tube design that gives you critically sharp images with vivid, lifelike, thrilling color fidelity
- Dynamic Picture—Sony's new system that automatically and continuously adjusts picture contrast level to capture the full dynamic range of your TV signal, so you see more detail in both bright and dark areas of every scene
- Dynamic Color Circuitry, for superior color reproduction with natural facial color tones and purer whites
- Colorpure Filter to improve fine picture detail without color spill or color noise distortion
- Sony's exclusive Velocity Modulation Scanning system, to give you a brilliant large-screen picture with increased sharpness and higher resolution than ever before possible
- Pulse Lock Power supply circuitry for greater picture and sound stability even during electrical current fluctuations
- Built-in stereo amplifier for use with your choice of Profeel component speakers—a perfect way to prepare for future stereo television broadcasts
- 10 watt stereo-output (5 watts per speaker) at 8 ohm load with bass boost
- All-new 100% solid state high-performance/high-resolution chassis circuitry designed to achieve studio-quality video fidelity
- Video and stereo audio input connectors for your Profeel Access Tuner giving you direct selection to any signal from the Profeel Access Tuner or desired audio/video source
- RGB inputs for higher horizontal resolution with increased character capability in micro-computer and teletext applications; 80 characters per line
- Tinted glass filter for improved picture contrast in any room light
- Superb space-age design to express the state-of-the-art in home entertainment engineering; modular Profeel styling to give you an integrated component look and feel

**KX-2501** **\$1500.00**  
 Profeel Component TV with 25-inch screen. VMC-15 Audio RK105 34 PIN RGB Connector. 22½"H x 26"W x 19"D. 122 lbs.

**KX-1901** **\$850.00**  
 Profeel Component TV with 19-inch screen. 17½"H x 19¾"W x 19. 73 lbs.

**VK-2D (8 PIN)** **\$20.00**  
 • Provides audio/video/control signal from Profeel Access Tuner to KX-2501 or KX-1901 • Supplied with VTX-1000R Profeel Access Tuner • 8 pin DIN type male connectors • Length: 6.6 feet

### VTX-1000R Profeel® Access Tuner® **\$520.00**

High-technology, high-performance Profeel Access Tuner designed to complement your choice of Profeel Trinitron Component® TVs—and give you direct access to VHF, UHF, even Cable TV broadcast channels, with unequaled selectivity and sensitivity! Your Profeel Access Tuner® also integrates your Videocassette Recorder, Video Disc Player, or other video signal sources into a single control center... plus giving you Sony's 10-key Express Commander® remote control convenience from anywhere in your room! Supplied with VTX-1000R Profeel Access Tuner. Infrared remote control unit that provides complete VHF/UHF/Cable TV channel selection. Supplied with 2-10 Meter VMC-15 video cable, 1-VK2D DIN cable, 1-RK-74A SPR cable. 3½" x 17" x 11". 11 lbs.

### SS-X10A Component TV Speaker System **\$130.00/pr.**

- Free-standing design styling to complement your Profeel Trinitron Component TV with direct connection to its Built-in stereo amplifier for complete systems integration
- 2-way speaker design delivers superb sound reproduction across the entire audio spectrum
- Big, powerful 5" woofer for rich and resonant lows
- High-performance 3" tweeter for crystal-clear highs
- Magnetically shielded design to eliminate interference with your TV signal
- Super-high audio input level capability (up to 35 watts)

Dimensions 17½" x 5½" x 5½" each. 8 lbs.

### SS-X1A Component TV Speaker System **\$80.00/pr.**

- Designed to mount directly on your Profeel Trinitron Component TV and connect with its built-in stereo amplifier, for full audio/video system integration
- 2-way closed speaker design delivers rich, resonant, audio reproduction to enhance your enjoyment of every TV program you watch
- 3.3" magnetically shielded woofer eliminates interference with your TV signal to produce deep, stirring bass tones
- 2" high performance tweeter delivers crystal-clear highs
- High audio input level capability (up to 15 watts)
- Metal mesh speaker grille for clear, undistorted sound
- Built-in bracket for simple, quick attachment to your Profeel Trinitron Component TV
- Dimensions 4½" x 8" x 3-3/8" each. 3 lbs.

### VK-5DX (8 PIN DIN) Multi-Connector Extension Cable **\$25.00**

- 16-foot multi-connector cable extension for VK-2D • Connects VTX-1000R Profeel • Access Tuner to KX-2501 or KX-1901 Profeel Trinitron Component TV

# soundolier, inc.

## CABINETS

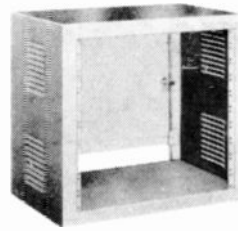

Series 400

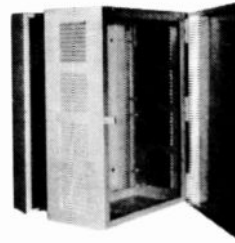

Series 300

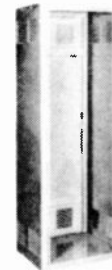

Series 100

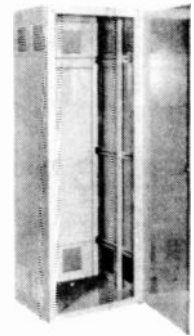

Series 200

### Cabinet Relay Racks

**SERIES 100** cabinet relay racks are designed for standard 19" (483mm) panels. Constructed of 16 ga. CRS throughout. Rear door lock and low profile handle included. Panel mounting angles are tapped to accept 10-32 pan head screws included. Louvers are internal type for improved ventilation. Iron phosphate coated for rust prevention and paint adhesion. Knockouts located at rear top and bottom. If no color is specified, Soundolier grey hammertone will be furnished. Consult your price sheet for complete list of colors available. Shipped knocked down. Hardware and instructions included.

#### OPTIONS:

**Series 110** Front Door — mounted on a ridged continuous hinge. May be ordered with or without cabinet. See specification chart for model numbers.

**Series PT** Panel Trim — stainless steel trim for covering panel mounting hardware. Complete with fasteners. Specify model PT-36, PT-42, PT-61, PT-70 or PT-77.

MODEL NO.	WIDTH	HEIGHT	DEPTH	PANEL SPACE	OPTIONAL FRONT DOOR	PRICE
100-36	22 1/2" (575mm)	41" (1041mm)	18 1/2" (470mm)	36 1/4" (933mm)	110-36	\$163.00
100-42	22 1/2" (575mm)	46 5/8" (1176mm)	18 1/2" (470mm)	42" (1067mm)	110-42	174.00
100-61	22 1/2" (575mm)	65 7/8" (1662mm)	18 1/2" (470mm)	61 1/4" (1556mm)	110-61	202.00
100-70	22 1/2" (575mm)	74 3/8" (1888mm)	18 1/2" (470mm)	70" (1778mm)	110-70	225.00
100-77	22 1/2" (575mm)	81 1/8" (2065mm)	18 1/2" (470mm)	77" (1956mm)	110-77	236.00

### Transmitter Racks

**SERIES 200** Transmitter Racks are designed to mount standard 19" (483mm) panels. Constructed of 16 ga. CRS throughout. Front and rear door handles and locks provided (locks keyed differently for security). Modern internal louvers for improved ventilation. The 11 ga. panel mounting angles are tapped for 10-32 screws (included) and are adjustable to any distance from front to rear. Panel angles are mounted to three sturdy channel slides on each side. Knockouts are located at rear top and bottom. If no color is specified, Soundolier grey hammertone will be furnished. Consult your price sheet for complete list of colors available. Shipped knocked down. Hardware and instructions included.

MODEL NO.	WIDTH	HEIGHT	DEPTH	PANEL SPACE	PRICE
200-36	22 1/2" (568mm)	41" (1041mm)	18 1/2" (470mm)	36 1/4" (933mm)	\$263.00
200-42	22 1/2" (568mm)	46 5/8" (1176mm)	18 1/2" (470mm)	42" (1067mm)	284.00
200-61	22 1/2" (568mm)	65 7/8" (1662mm)	18 1/2" (470mm)	61 1/4" (1556mm)	332.00
200-70	22 1/2" (568mm)	74 3/8" (1888mm)	18 1/2" (470mm)	70" (1778mm)	359.00
200-77	22 1/2" (568mm)	81 1/8" (2065mm)	18 1/2" (470mm)	77" (1956mm)	380.00

### Sectional Wall Mounting Cabinets

**SERIES 300** Sectional Wall Cabinets are designed for standard 19" (483mm) rack panels. Entire cabinet is constructed of 16 ga. CRS. Back and front sections are one piece construction with angle braces at each corner. All seams and miters are electric welded and ground smooth. Center cabinet is strengthened with 16 ga. braces at each corner. Three larger models have 11 ga. mounting supports on back section. Removable pin hinges for easy assembly and hinges are bolted to cabinet section for greater strength. Knockouts and internal louvers are two Soundolier exclusives. Center section and rear section are secured with locking rods and alignment pins. Front section is complete with cylinder lock. All models have tapped panel mounting rails and 10-32 pan head screws for panel mounting. If no color is specified, Soundolier grey hammertone will be furnished. Consult price sheet for colors available. Shipped completely assembled.

MODEL NO.	WIDTH	HEIGHT	REAR SECTION DEPTH	CENTER SECTION DEPTH	FRONT SECTION DEPTH	PANEL SPACE	PRICE
300-17	20 3/8" (524mm)	20 1/2" (521mm)	4 1/2" (114mm)	11" (279mm)	2" (51mm)	17 1/2" (445mm)	\$153.00
300-21	20 3/8" (524mm)	24" (610mm)	4 1/2" (114mm)	11" (279mm)	2" (51mm)	21" (533mm)	166.00
300-26	20 3/8" (524mm)	29 1/4" (743mm)	4 1/2" (114mm)	11" (279mm)	2" (51mm)	26 1/4" (667mm)	185.00
300-28	20 3/8" (524mm)	31" (787mm)	4 1/2" (114mm)	11" (279mm)	2" (51mm)	28" (711mm)	227.00
300-42	20 3/8" (524mm)	45" (1143mm)	4 1/2" (114mm)	11" (279mm)	2" (51mm)	42" (1067mm)	321.00
300-61	20 3/8" (524mm)	64 1/2" (1632mm)	4 1/2" (114mm)	11" (279mm)	2" (51mm)	61 1/4" (1556mm)	378.00

### Desk Top Cabinet

**SERIES 400** desk top cabinets are completely assembled and constructed from 16 ga. CRS throughout. Each unit is equipped with a locking rear door which is mounted on sturdy slip joint hinges. Internal louvers and recessed panel angles give this compact cabinet a "clean look." The panel mounting angles are tapped for 10-32 screws. Designed to mount most Soundolier cabinet accessories.

If no color is specified, Soundolier grey hammertone will be furnished. Consult your price sheet for complete list of colors

MODEL NO.	WIDTH	HEIGHT	DEPTH	PANEL SPACE	PRICE
400-12	22 1/2" (565mm)	15 1/2" (392mm)	15 1/2" (391mm)	12 1/2" (314mm)	\$ 87.00
400-17	22 1/2" (565mm)	20 1/2" (525mm)	15 1/2" (391mm)	17 3/8" (448mm)	105.00
400-24	22 1/2" (565mm)	27 1/2" (703mm)	15 1/2" (391mm)	24 1/4" (625mm)	118.00
400-31	22 1/2" (565mm)	34 1/2" (881mm)	15 1/2" (391mm)	31 1/4" (803mm)	135.00

NOTE: All prices FOB Factory.

Prices and Specifications Subject to Change Without Notice.

# soundolier, inc.

## FLOOR STANDING CABINETS

### 500 Series Multi Racks

**SERIES 500** Multi Racks are designed for standard 19" (483mm) rack panels and for maximum flexibility. Multi Racks can be readily joined together and because of its open side construction, wiring is simple and convenient. Each basic rack is supplied with a rear door complete with cylinder lock and low profile handle and slip-jointed hinges. Panel mounting rails are adjustable, manufactured of 11 ga. CRS and tapped for 10-32 screws. Construction of all other parts is 16 ga. CRS. Combination knockouts are located on the top, bottom and rear flanges. To facilitate cable entry, three 2-13/16" (71mm) diameter holes are located toward the rear of the base of the rack.

Multi Racks are shipped welded and assembled. All metal surfaces receive an iron phosphate coating prior to finishing for rust prevention and maximum paint adhesion. If no color is specified, Soundolier grey hammertone will be furnished. Consult your price sheet for complete list of colors available.

#### OPTIONAL ACCESSORIES:

**SERIES 510** Front Doors are easily field installed with either right or left hand hinging. The basic rack is furnished with a series of small knockouts on each side of the front return. These knockouts are easily removed and will accept the 10-32 self tapping screws furnished with the door. Complete with continuous piano hinge, lock and low profile handle.

**SERIES 530** Mounting Rails — While each basic rack is supplied with one set of mounting rails, extra sets are available at customer's option.

**SERIES 540** Side Panels — One pair of side panels is required to close either a single basic rack or multiple racks attached. The side panels install easily by hooking them over internal side channels in the basic rack.

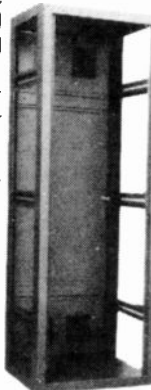

500 Series

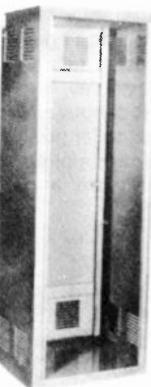

WA-100



WA-200



Series 510

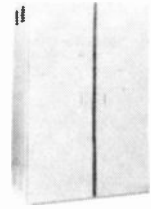

Series 530

MODEL NO.	DESCRIPTION	WIDTH	HEIGHT	DEPTH	PANEL SPACE	PRICE
500-61	BASIC RACK*	22 $\frac{1}{2}$ " (568mm)	65 $\frac{1}{2}$ " (1664mm)	18 $\frac{1}{2}$ " (470mm)	61 $\frac{1}{4}$ " (1556mm)	\$382.80
500-70	BASIC RACK*	22 $\frac{1}{2}$ " (568mm)	74 $\frac{1}{2}$ " (1886mm)	18 $\frac{1}{2}$ " (470mm)	70" (1778mm)	411.64
500-77	BASIC RACK*	22 $\frac{1}{2}$ " (568mm)	81 $\frac{1}{2}$ " (2065mm)	18 $\frac{1}{2}$ " (470mm)	77" (1956mm)	426.30
510-61	FRONT DOOR	21 $\frac{1}{8}$ " (543mm)	63 $\frac{3}{8}$ " (1608mm)	1" (25mm)	61 $\frac{1}{4}$ " (1556mm)	116.90
510-70	FRONT DOOR	21 $\frac{1}{8}$ " (543mm)	72 $\frac{1}{2}$ " (1830mm)	1" (25mm)	70" (1778mm)	129.36
510-77	FRONT DOOR	21 $\frac{1}{8}$ " (543mm)	79 $\frac{1}{8}$ " (2008mm)	1" (25mm)	77" (1956mm)	136.80
530-61	MTG RAILS**	—	—	—	61 $\frac{1}{4}$ " (1556mm)	74.54
530-70	MTG RAILS**	—	—	—	70" (1778mm)	84.12
530-77	MTG RAILS**	—	—	—	77" (1956mm)	91.96
540-61	SIDE PANELS	18 $\frac{1}{2}$ " (460mm)	65 $\frac{1}{2}$ " (1657mm)	$\frac{3}{8}$ " (16mm)	61 $\frac{1}{4}$ " (1556mm)	156.16
540-70	SIDE PANELS	18 $\frac{1}{2}$ " (460mm)	74" (1880mm)	$\frac{3}{8}$ " (16mm)	70" (1778mm)	172.56
540-77	SIDE PANELS	18 $\frac{1}{2}$ " (460mm)	81" (2057mm)	$\frac{3}{8}$ " (16mm)	77" (1956mm)	185.74

\*BASIC RACK INCLUDES REAR DOOR AND 1 PAIR TAPPED ADJUSTABLE MOUNTING RAILS

\*\*ADDITIONAL MOUNTING RAILS ARE OPTIONAL

### Cabinet Relay Rack — Welded Construction

**SERIES WA 100** cabinet relay racks are constructed of 16 ga. CRS and are completely welded for additional strength and neater appearance. The panel mounting angles are tapped for 10-32 screws. The rear door is attached by slip-jointed hinges and includes lock and low profile handle. The entire cabinet receives an iron phosphate coating for rust prevention and excellent paint adhesion. If no color is specified, Soundolier grey hammertone will be furnished. Consult your price sheet for complete list of colors available.

### Transmitter Rack — Welded Construction

**SERIES WA200** transmitter racks are constructed of 16 ga. CRS and are completely welded for additional strength and neater appearance. The adjustable mounting angles are 11 ga. CRS and are tapped for 10-32 screws. The front and rear doors include locks and low profile handles. The locks are keyed differently for security. The entire cabinet receives an iron phosphate coating for rust prevention and excellent paint adhesion. If no color is specified, Soundolier grey hammertone will be furnished. Consult your price sheet for complete list of colors available.

MODEL NO.	WIDTH	HEIGHT	DEPTH	PANEL SPACE	PRICE
WA100-36	22 $\frac{1}{2}$ " (568mm)	41" (1041mm)	18 $\frac{1}{2}$ " (470mm)	36 $\frac{1}{2}$ " (933mm)	\$253.96
WA100-42	22 $\frac{1}{2}$ " (568mm)	46 $\frac{1}{2}$ " (1176mm)	18 $\frac{1}{2}$ " (470mm)	42" (1067mm)	264.80
WA100-61	22 $\frac{1}{2}$ " (568mm)	65 $\frac{1}{4}$ " (1662mm)	18 $\frac{1}{2}$ " (470mm)	61 $\frac{1}{2}$ " (1556mm)	303.22
WA100-70	22 $\frac{1}{2}$ " (568mm)	74 $\frac{1}{2}$ " (1888mm)	18 $\frac{1}{2}$ " (470mm)	70" (1778mm)	337.96
WA100-77	22 $\frac{1}{2}$ " (568mm)	81 $\frac{1}{4}$ " (2065mm)	18 $\frac{1}{2}$ " (470mm)	77" (1956mm)	354.22

MODEL NO.	WIDTH	HEIGHT	DEPTH	PANEL SPACE	PRICE
WA200-36	22 $\frac{1}{2}$ " (568mm)	41" (1041mm)	18 $\frac{1}{2}$ " (470mm)	36 $\frac{1}{2}$ " (933mm)	\$404.56
WA200-42	22 $\frac{1}{2}$ " (568mm)	46 $\frac{1}{2}$ " (1176mm)	18 $\frac{1}{2}$ " (470mm)	42" (1067mm)	438.50
WA200-61	22 $\frac{1}{2}$ " (568mm)	65 $\frac{1}{4}$ " (1662mm)	18 $\frac{1}{2}$ " (470mm)	61 $\frac{1}{2}$ " (1556mm)	509.02
WA200-70	22 $\frac{1}{2}$ " (568mm)	74 $\frac{1}{2}$ " (1888mm)	18 $\frac{1}{2}$ " (470mm)	70" (1778mm)	542.94
WA200-77	22 $\frac{1}{2}$ " (568mm)	81 $\frac{1}{4}$ " (2065mm)	18 $\frac{1}{2}$ " (470mm)	77" (1956mm)	567.30



# soundolier, inc.

## CABINET ACCESSORIES

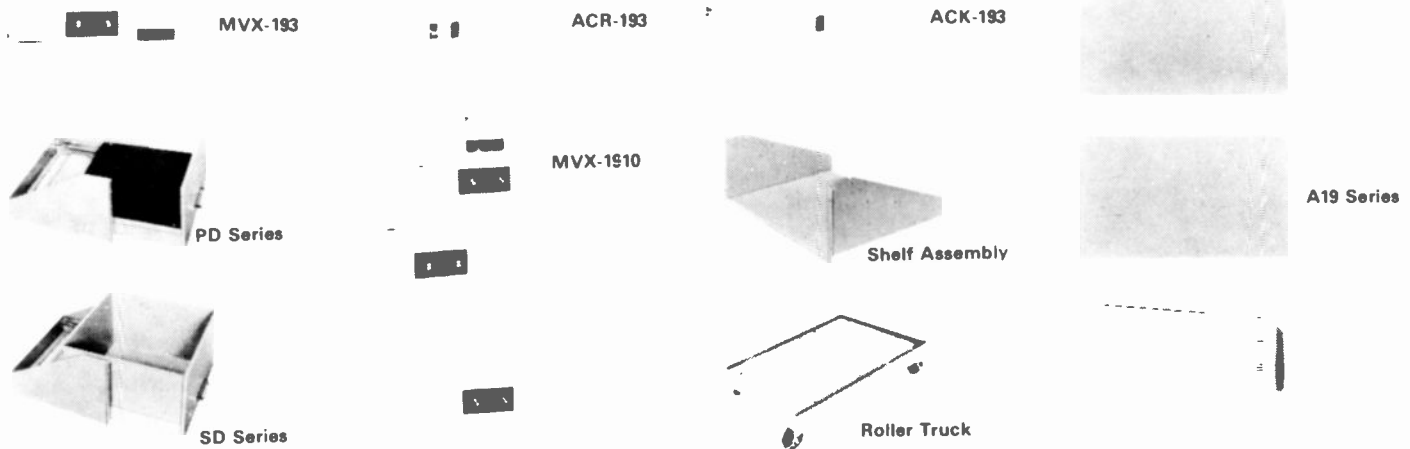

### PD SERIES PHONO DRAWERS

PD SERIES phono drawers are constructed of 16 ga. CRS and designed to mount in standard 19" (483mm) rack panel space. The chassis is mounted on slides with nylon tired bearing rollers. The chassis is complete with a handsome 1/4" (6mm) thick walnut grain masonite base. Partial and full drawer extension models are available. Consult the current Soundolier price sheet for standard colors.

MODEL	PANEL SPACE	DEPTH	DRAWER EXTENSION	USED IN SERIES	PRICE
PD10 16	10 1/2" (267mm)	16 1/2" (410mm)	12" (305mm)	100, 200, 500	\$108.22
PD10 165	10 1/2" (267mm)	16 1/2" (419mm)	16" (406mm)	100, 200, 500	140.12
PD10 14	10 1/2" (267mm)	14 1/2" (368mm)	10" (254mm)	100, 200, 300, 400, 500	98.02
PD10 145	10 1/2" (267mm)	14 1/2" (368mm)	14" (356mm)	100, 200, 300, 400, 500	127.18

### SD SERIES STORAGE DRAWERS

SD SERIES storage drawers are ideal for tapes, records, microphones and other accessories. Constructed in 16 ga. CRS and designed for standard 19" (483mm) rack panel space. Complete with nylon tired roller bearings. Available in a choice of panel space sizes, overall depth and either partial or full drawer extension. Consult the current Soundolier price sheet for standard colors.

MODEL	PANEL SPACE	DEPTH	DRAWER EXTENSION	USED IN SERIES	PRICE
SD7 14	7" (178mm)	14 1/2" (368mm)	10" (254mm)	100, 200, 300, 400, 500	\$105.94
SD7 145	7" (178mm)	14 1/2" (368mm)	14" (356mm)	100, 200, 300, 400, 500	134.22
SD7 16	7" (178mm)	16 1/2" (419mm)	12" (305mm)	100, 200, 500	109.52
SD7 165	7" (178mm)	16 1/2" (419mm)	16" (406mm)	100, 200, 500	139.56
SD10 14	10 1/2" (267mm)	14 1/2" (368mm)	10" (254mm)	100, 200, 300	111.08
SD10 145	10 1/2" (267mm)	14 1/2" (368mm)	14" (356mm)	100, 200, 300	141.40
SD10 16	10 1/2" (267mm)	16 1/2" (419mm)	12" (305mm)	100, 200, 500	114.86
SD10 165	10 1/2" (267mm)	16 1/2" (419mm)	16" (406mm)	100, 200, 500	146.70

### SHELF ASSEMBLY

MODEL SH19-7 shelf assembly is constructed of 16 ga. CRS and is easily mounted to the panel mount rails of all standard 19" (483mm) racks. Requires 7" (178mm) of panel space. Ideal for mounting equipment that does not have an attached rack mount panel. Available in a choice of standard colors. Consult your Soundolier price sheet. Shelf area dimensions — 17 1/2" (445mm) x 14" (356mm) x 7" (178mm) high.

\$31.54

### ROLLER TRUCK

MODEL CT1020 roller truck is constructed of 16 ga. CRS and is designed for Soundolier's 100, 200 WA100, WA200 and 500 series cabinets. The roller truck is complete with four 3" (76mm) ball bearing casters. Two casters are the rigid type and two are the swivel type. The swivel casters are also the locking type. The total load capacity is 400 lbs (181kg). Consult your current Soundolier price sheet for available standard colors. Dimensions — 24-13/16" (630mm) x 21" (533mm).

\$168.54

### BLANK PANELS AND VENT PANELS

S19 SERIES panels are constructed of 1/16" (2mm) CRS. Two sides of the panel are formed for rigidity. The panel mount holes are oblong for adjustment and neater appearance. Consult your Soundolier price sheet for standard colors.

A19 SERIES panels are constructed of 1/8" (3mm) aluminum. Panel mount holes are oblong for adjustment and neater appearance. Panels are painted on one side. Consult your Soundolier price sheet for standard colors.

SVP19 SERIES vent panels are constructed of 22 ga. perforated CRS. Two sides are formed for rigidity. Panel mount holes are oblong for adjustment and neater appearance. Consult your Soundolier price sheet for standard colors.

PANEL SPACE	S19 SERIES CRS	A19 SERIES ALUMINUM	SVP19 SERIES VENT
1 1/2" (44mm)	S19-A 96.76	A19 1 96.50	SVP19 1 \$10.52
3 1/2" (89mm)	S19 3 7.02	A19 3 7.76	SVP19 3 12.12
5 1/2" (133mm)	S19-5 7.98	A19 5 11.00	SVP19 5 13.70
7" (178mm)	S19 7 8.96	A19 7 12.52	SVP19 7 15.02
8 1/2" (222mm)	S19 8 10.24	A19 8 15.52	SVP19 8 16.58
10 1/2" (267mm)	S19 10 12.28	A19 10 19.32	SVP19 10 18.12
12 1/2" (311mm)	S19 12 14.72	A19 12 21.10	SVP 12 19.74
14" (356mm)	S19 14 16.22	A19 14 23.82	-
15 1/2" (400mm)	S19 15 16.24	A19 15 26.08	-
17 1/2" (445mm)	S19 17 17.30	A19 17 28.82	-
19 1/2" (489mm)	S19 19 19.74	A19 19 31.38	-
21" (533mm)	S19 21 20.48	A19 21 36.38	-

### 5 CHANNEL MONITOR PANELS

MODEL MVX-193 monitor panel is a compact (3 1/2" (89mm) CRS panel and is designed to be used with any multi-channel commercial or industrial sound system. It will provide aural and visual monitoring instantly with the turn of a switch. A double pole, six position switch with an attractive brushed aluminum inlay knob is wired to supply five different program channels with a sixth "off" position. Each channel conveniently connects to two screw terminals on the rear of the panel to provide balanced switching. All wiring to the external terminals is completed at the factory. Either a 70 volt or 25 volt line may be monitored. The monitor channel switch is conveniently mounted on a black plate with attractive white silk screened nomenclature and then is separately mounted to the panel. Through this arrangement, a free choice of colors to match any system is available. If a color is not specified, Soundolier grey hammertone will be used.

A 3" (76mm) speaker with transformer is used for aural monitoring. The speaker is connected through a continuous rotation potentiometer for proper level selection in monitoring. The control is mounted on the same plate as the channel selector switch. The speaker grille is attractively raised and contributes handsomely to the modern look of the entire unit.

The VU meter has a long life thermoplastic case trimmed in black to blend with the black selector switch, volume control inset. A rear adjustment provides the capability to set the meter at a 0 dB level on a 70 volt or 25 volt line. A zero adjust on the face of the meter completes its flexibility. A set of instructions is provided with each unit.

\$213.60

MODEL MX-193 is identical to MVX-193 except the VU meter is not provided. All other specifications are the same.

\$159.56

MODEL MVX-1910 is identical to MVX-193 except the panel is 10 1/2" (267mm) high instead of 3 1/2" (89mm) high, and the monitor speaker is an 8" (203mm) unit rather than a 3" (76mm) unit. All other specifications are the same.

\$225.28

MODEL MX-1910 is identical to MVX-1910 except a VU meter is not provided. All other specifications are the same.

\$175.76

### AC POWER PANELS

MODEL ACR-193 master power panel is designed to provide a single switch which controls all AC power in any industrial or commercial sound system. The main switch is a DPST rocker type and is capable of switching both sides of the power line. A red jewel, long life, neon pilot lite indicates visually whether the AC power is on or off. Eight outlets are provided with six controlled by the main and the remaining two uncontrolled. Each outlet is grounded (3 contacts). A 15 amp fuse is included. A hole is provided for the connection of 1/2" (13mm) conduit to the rear of the panel. All wiring is completed at the factory. Color selections are the same as monitor panels above.

\$144.44

MODEL ACK-193 is identical to the model ACR-193 except for the use of a DPST key switch. This prevents unauthorized personnel from turning the entire system on or off. Two keys are provided. All other specifications remain the same.

\$161.70

	SPECIFICATIONS	
	ACR-193	ACK-193
PANEL RATING	15 AMPS	15 AMPS
SWITCH RATING	15AMPS	15AMPS
OUTLETS SWITCHED	6	6
OUTLETS UNSWITCHED	2	2
PILOT LITE	YES	YES
PANEL SIZE	19" x 3 1/2" (489 x 89mm)	19" x 3 1/2" (489 x 89mm)
WEIGHT	7 LBS(3 175kg)	7 LBS(3 175kg)
FINISH	SAME AS MONITOR PANELS ABOVE	



## SLIDE PROJECTOR

# PRODUCER 32 SELECTROSLIDE

## FILM CHAIN 2x2 SLIDE PROJECTOR

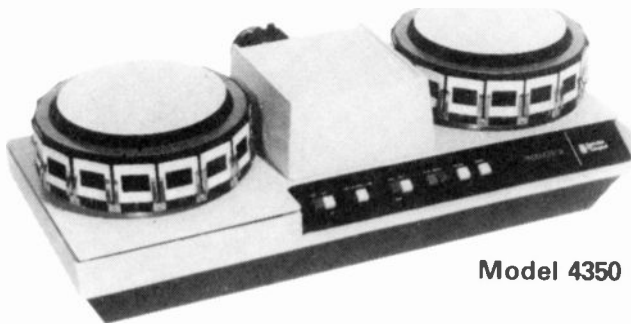

Model 4350



Model 4351

Sixteen different dissolve rates, left and right crawls, high speed random access, and an easily edited 451-cue electronic memory system are just a few of the exclusive features of Spindler and Sauppé's new Producer 32 Selectroslide Projector, the world's first slide projector to incorporate a microprocessor. The unit is designed to work in a television film chain where it utilizes a single port of the multiplexer, and it is equally applicable to the job of converting slide presentations to motion picture film directly from the projector.

A forty-six button, rack-mounted master controller remotes all projector functions to the control studio. Thirty-three status lights indicate the exact condition of the projector at all times, and a seven-digit readout shows slide tray positions and the number of the upcoming cue. Limited function remote controls may be located in additional studios to make available sequential slide advance and reverse as well as random slide selection. Controls on the projector itself are limited to those related to setup.

Precise timing codes may be used to link together a series of cues to initiate more than one dissolve function. Once loaded, the memory may be advanced or reversed one cue at a time or at a speed of ten cues-per-second, and the slide trays will automatically track to their appropriate position and lamp status for the stopping point. A Restart Button returns the system to Cue #1, automatically bringing both memory and slide trays back to their starting positions.

Each of the two slide trays may be programmed to move forward or backward to any other tray position, and this may be done as either a fast series of conventional slide changes or as a slow crawl. Between screenings, programming data is stored in a cluster on standard recording tape. Subsequently, it is high speed re-entered into memory for re-use. In performance, cues may be called from memory manually by pressing the Cue Button of the controller, or

the presentation may be fully automated from synchronization pulses on one of the channels of the soundtrack tape.

In one-second increments, dissolve rates are available from a Cut of a fraction of a second up to a fifteen-second lap dissolve. Slides may be made to move slowly, either left-to-right or right-to-left, in a crawl that takes approximately six seconds per slide position. It is also possible to fade-in or fade-out a slide at any of sixteen different speeds. Slides may be projected from both trays simultaneously to create superimpositions.

An automated presentation may be interrupted at any time by calling up a slide from the random access section. Maximum selection time is less than two seconds. As the appropriate tray advances to the selected slide, the opposite tray tracks with it to retain correct numerical sequence. Manual controls also include sequential advance and reverse buttons which change slides at the speed of a Cut.

The pair of slide trays on the Producer 32 Projector carry a total capacity of thirty-two slides and may be quickly changed without disturbing a presentation. Lights within the projector make it possible to preview all slides without rotating the trays. The unit uses 1000-hour, tungsten-halogen projection lamps, and the "soft start" dissolve circuitry extends lamp life by a minimum factor of two.

At the heart of the optical system is a precision, cube prism, beam splitter. There are no moving parts. Two etched, aspheric condensing lenses and variable density field flatteners eliminate filament focus and provide evenness of illumination. Available are 7 1/2" and 9" lenses for multiplexers, and inverted 3" and 5" projection lenses for uniplexing.

### PRICE LIST

P-32 Producer 32 Selectroslide projector (Model 4350), with 7 1/2" lens (Model 290 or 291), controller (Model 4351), and mounting plate (Model 6382). Specify cable length at \$4.36 per foot, otherwise 5' controller cable supplied ..... **\$15,290.00\***

S-32 Spectrum 32 Selectroslide projector (Model 4344) for sequential slide presentation only, (with 7 1/2" lens), and mounting plate (Model 6382) ..... **\$10,450.00**

<b>Model</b>	
<b>241</b>	Slide magazine, 16-slide, odd numbering ..... <b>\$176.00</b>
<b>242</b>	Slide magazine, 16-slide, even numbering ..... <b>176.00</b>
<b>BCL</b>	Projection lamp, 300 watt, 1000 hour average life .... <b>30.00</b>
<b>6344</b>	Remote control panel for S-32D, w/5 ft. cable (additional cable at \$1.40 per foot) ..... <b>875.00</b>
	Following Prices: Request Quote
<b>285</b>	3" f 3.5 inverted lens for uniplexing, picture size 14 ..... <b>176.00</b>
<b>286</b>	5" f 3.5 inverted lens for uniplexing, picture size 14 ..... <b>176.00</b>
<b>290</b>	7 1/2" f 4.0 projection lens, picture size 1-9, with iris ..... <b>176.00</b>
<b>291</b>	7 1/2" f 4.0 projection lens, picture size 6-12, with iris ..... <b>176.00</b>
<b>295</b>	9" f 5.0 projection lens, picture size 1-9, with iris ..... <b>176.00</b>
<b>297</b>	9" f 5.0 projection lens, picture size 6-11, with iris ..... <b>176.00</b>

\* Projectors with lens sizes other than 7 1/2" must be quoted separately.

### PROJECTED PICTURE SIZES

PICTURE SIZE	FIELD LENS	PICTURE SIZE
1	4.50"	x 3.375"
2	4.44"	x 3.33"
3	4.30"	x 3.22"
4	4.00"	x 3.00"
5	3.75"	x 2.81"
6	3.19"	x 2.38"
7	2.92"	x 2.19"
8	2.70"	x 2.04"
9	2.50"	x 1.88"
10	2.40"	x 1.80"
11	2.16"	x 1.62"
12	2.00"	x 1.50"
13	1.125"	x 0.844"
14	0.50"	x 0.375"

### Professional Sun Gun movie light lamps

EKT	\$26.72
FAV	29.94
FBT	32.64
FBV	35.45
FBW	38.47

### Miniature Tungsten Halogen 2 pin base lamps

BHC/DYS/DYV	\$20.09
DVY	23.00
DYH	24.36
EKD	24.09
FBD	25.81

### Minican Base single ended tungsten halogen lamps

EHT (250Q/CL)	\$24.91
EHV	28.99

### Mogul Prefocus lamps for follow-spotlights

DTA	\$83.69
-----	---------

### Two pin tungsten halogen lamps

EHC/EHB(500Q/4CL)	\$48.51
EHD(500Q/1CL)	48.51
EHF(750Q/4CL)	53.66
EHG(750Q/CL)	53.66
FCV(1000Q/4)	60.16
FEL(1000Q/4CL)	49.86
FEP(1000Q/4CL/HV)	56.19

### Double ended tungsten halogen lamps 5 5/8" MOL

DWT(1000T6Q/RCL)	\$72.35
FER(1000T6Q/4CL)	58.54
FEX(2MT8Q/4CL/HV)	103.76
FEY(2MT8Q/4CL)	98.37

### Double ended tungsten halogen lamps 6 9/16" MOL

FDB	\$56.10
FFT(1000T3Q/1CL)	51.77
FFW(2000T4Q/4CL)	62.29

### Double ended tungsten halogen lamps 3 3/4" MOL

DXN	\$32.23
DXW	32.83
FBY	33.49
FBZ	23.81
FCB	21.91

### Double-ended tungsten halogen lamps with 4 3/8" MOL

DYA	\$35.96
-----	---------

### Moqul bipost lamps with 5" LCL for fresnel lens spotlights

BWA(2MQ/4CL/MP)	\$115.15
CXZ(1500Q/4CL/MB)	105.41
CYV(1MQ/4CL/MB)	82.65
CYX(2MQ/4CL/MB)	113.66
DPY(5MQ/4CL)	452.55

### Intermediate wattage double-ended tungsten halogen lamps 3 1/8" MOL

DWY	\$23.28
DXX	21.60
EHP(300T4Q/CL)	33.88
FAD	19.23
FBX	34.53
FCA	22.49
FDA(400T4Q/4CL)	29.26

### Universal T-3 double-ended tungsten halogen 4 11/16" MOL

EHM(300T2 1/2 Q/CL)	\$36.86
EHZ(300T2 1/2 Q)	43.87
EJG(750T3Q/4CL)	38.21
FCL(500T3Q/CL/U)	23.57
FCM(1000T3Q/4CL)	29.81
FCZ(500T3Q/U)	33.08
FDL(500T2 1/2 Q/4CL)	29.81
FDN(500T2 1/2 Q/4/U)	28.73
FHM(1000T3Q 1/4)	33.08

### Par Reflector Lamps

DWE	\$33.86
DXK	36.34
FAY	48.21
FCX	33.86
FFN(1000PAR64Q/VNSP/1)	72.82
FFP(1000PAR64Q/NSP/2)	72.82
FFR(1000PAR64Q/MFL/5)	72.82
FFS(1000PAR64Q/WFL/6)	72.82

### R type reflector lamps and movie lights

BAH	\$2.64
BBA	2.17
BCA	2.43
BEP	6.21
BFA	9.23
DAN	8.36
DWC	4.11
DWD	7.43
DXC	7.40
DXH	7.87
DXR/DXS	10.15
DXT	15.23
EAL	9.40
EBR	9.23
EBV	2.21
EBW	3.13
ECT	2.60
FAE	10.04

### Screw base lamps for scoop fixtures

DSE(1MT20Q/4)	\$48.24
DSF(1500T20Q/4)	56.10

### Screw Base Spotlight Lamps

BWF	\$124.65
BWG	131.69

### High wattage lamps for fresnel lens spotlights and sky pans

DTY(10MQ/4CL)	\$877.50
---------------	----------

### Low wattage lamps for Miniature Spotlights

BEJ	\$10.32
BVR	6.49
CAW/CAX	5.30
CBJ/CBC	9.60
CBX/CBS	9.60
CCM/CHD	11.55
CEM	7.02
CEW/CFC	9.72
CHK	7.30
CLS/CLG	10.21
CLX/CMB	10.60
CMV/CMT	14.81
FEV	28.73

### Medium bipost lamps 4" LCL for Ellipsoidal Spotlights

BSC(750Q/4CL/4B)	\$477.77
BSD(750Q/CL/4B)	49.96
DZD(1MQ64CL/4B)	50.06
EFX(500Q/CL/4B)	41.87

### Medium prefocus lamps with 3 1/2" LCL for Ellipsoidal spotlights

DEB(500T12/8)	\$33.97
DNS(5000T12/8)	31.97
DNT(750T12/9)	36.47
DNV(1MT12/2)	43.20
EGC/EGD(500Q/4CL/3 1/2 P)	53.66
EGE(500Q/CL/3 1/2 P)	53.66
EGF(750Q/4CL/3 1/2 P)	60.16
EGG(750Q/CL/3 1/2 P)	60.16
EGJ(1MQ/4CL/3 1/2 P)	63.14
EGK(1MQ/4/3 1/2 P)	65.29

### Medium prefocus lamps with 2 3/16" LCL for fresnel lens spotlights

BFK	\$25.49
DGH	31.28
DMX	19.40
DNW(500T20/64)	38.47
DRB/DRC	24.23
DRS	21.00
BTL(500Q/5CL/2 3/16P)	41.63
BTM(500Q/4CL/2 3/16P)	41.63
BTN(750Q/5CL/2 3/16P)	41.45
BTP(750Q/4CL/2 3/16P)	42.00
BTR(1MQ/4CL/2 3/16P)	47.15
EEX	33.21

### Medium bipost lamps with 2 1/2" LCL for fresnel lens spotlights

EGN(500Q/4CL/B)	\$41.58
EGR(750Q/4CL/B)	65.76
EGT(1MQ/4CL/B)	71.60

### Moqul prefocus lamps with 3 15/16" LCL for fresnel lens spotlights

BVT(1MQ/CL/MP)	\$70.20
BVV(1MQ/4CL/MP)	66.13
BVW(2MQ/4CL/MP)	76.70
CWZ(1500Q/4CL/MP)	86.62

# Technicolor

## Audio-Visual Systems

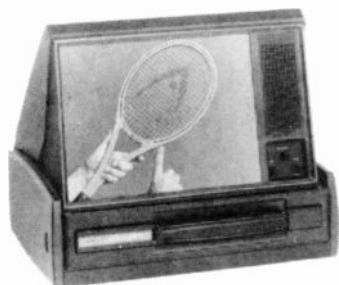

### Showcase Series Briefcase Projector

The Showcase travels as a handsome, brown grained attache case—performs as a sound Super-8 projector. It is cartridge loaded for easy operation which means no threading or rewinding. Features rear projection for one-on-one selling or front projection for large groups. Showcase is lightweight, only 21 lbs., yet offers a bright 10 1/2" x 7 1/2" picture even in lighted conditions. EPG 100 hour lamp is standard equipment and averages 500 hours with the lamp saver switch.

2000M Magnetic sound and 24 fps ..... **\$56.00**  
 2050M Magnetic sound, 24 fps and stop motion ..... **\$60.00**

### Showcase Shipping Case (C200)

Constructed of rugged lightweight materials with protected inner lining. Inside compartments for two film cartridges and spare lamp.

For Models 2000, 2000M, 2050M .. **\$80.00**

### Showcase Slip-Over Carrying Cover

Durable vinyl slip-over cover with handy pocket for film cartridge. Dark brown to match Showcase ..... **\$17.50**

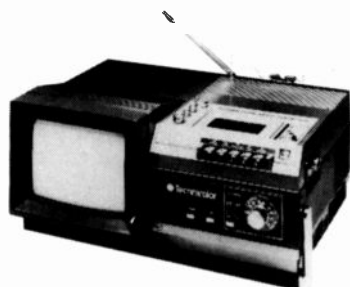

### Video Showcase Model 335

- VHF/UHF portable color TV set with an electronic channel selector
- 1/4" VCR with a tuner for recording TV programs
- 7.7" color monitor
- 3-way power: AC (110 VAC), self-contained rechargeable battery and external car/boat adaptor
- Playback on its own screen or any other TV receiver/monitor
- Carrying handle
- Dimensions: 18" x 13" x 8 1/2", Weight 21 lbs. **\$1795.00**
- Available without tuner **\$1645.00**

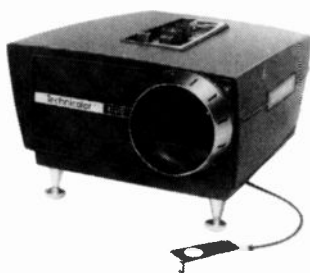

### Model 1100 Sound—Front Projection

Super-8 projector that fills an auditorium size screen, yet is so portable and easy to run a child can operate it. Technicolor endless loop sound cartridges hold up to 31 minutes of film. The 1100 comes with high intensity 200 hour EKE lamp (800 hours with the economical lamp saver switch). Optional lenses are available. Films can run continuously or stop at the end, ready to show again at the touch of a button. Includes remote start control.

1100M Magnetic sound and 24 fps ..... **\$69.00**

### Shipping Case (C115)

Foam lining protects projector, extra room for sound film cartridge and spare lamp

..... **\$92.00**



### RoadShow Portable Slide/Sound System

A complete, synchronized slide/sound system offering handsome portability and full protection. Its big 10 1/4" x 10 1/4" built-in screen converts quickly to front projection for larger audiences. Regular models 43 and 44 (Auto-Focus) are integrated with Kodak Ektagraphic carousel projectors with 80-slide capacity. Model 42 comes without projector; will accept any Kodak projector except Custom 800 and miniature models.

RoadShow features a quality cassette/recorder, microphone, customized amplification system and front speaker. Controls, screen and slide tray protected for travel or storage. Inaudible-pulse slide/sound synchronization.

RoadShow 43 Record and Playback ..... **\$645.00**  
 RoadShow 44 Record, Playback and Auto-Focus ..... **749.00**  
 RoadShow 42 without Projector, Record and Playback ..... **469.00**

### RoadShow Vinyl Carrying Covers

Slip on C-400 ..... **\$22.50**  
 C-600—Side Handle ..... **27.50**  
 Shipping Case—C-300 ..... **95.00**  
 Remote Cord—RA1 ..... **17.50**

## SLIDE/SOUND SYSTEMS



### Film Loop Player Silent—Front Projection

Silent, cartridge-loaded Super-8mm projector with stop motion. It is lightweight (7 lbs.), compact (9 1/2" x 5 1/2" x 7") and rugged for child use. Long-life, 100 hour EPF lamp is standard. Used in education worldwide.

820Z with Technor 20-32mm f/1.4 zoom lens ..... **\$239.00**  
 820WS with Technor 10mm f/1.1 wide angle lens ..... **269.00**

### Film Loop Player Carrying Case (C107)

Scuffproof vinyl finish—white matte projection screen in lid. For Models 820Z, 820WS ..... **\$44.00**

### Technor Adaptor Lenses

Technor Adaptor Lenses simply slip over the standard lens of all Model 1100 and 1000 series projectors. Technor lenses let you choose the picture size you want. No installation is needed. Place the projector almost anywhere and get the right size projection image—from 5 to 80 feet away. (L-10 lens for Mini Theater 3000 and L-15 lens for Mini Theater 7000 are standard equipment). To select the lens correct for specific application, check special projection chart.

Technor Lens L-7.5 ..... **\$65.00**  
 Technor Lens L-10, L-15 ..... **55.00**  
 Technor Lens L-28, L-40 ..... **75.00**

### Silent

Z (20-32mm f/1.4 zoom) ..... **\$40.00**  
 WS (10mm f/1.1 wide angle) ..... **\$4.00**



### Videocassette Recorder

Technicolor® has introduced a truly portable VCR for business, home, education and industry. It weighs only 7 lbs., including self-contained battery, and measures 10" x 10" x 3". An ingenious Micro Helical System allows the use of 1/4" Tape. Other features include: a fast-charge 12-volt NiCd battery, memory counter, condensation detection, sound dubbing capability and low power consumption.

Model 212. The VCR, AC Power Adaptor, battery, carrying strap, switch box cable to TV receiver, earphone, TV switch-box, Balun transformer (75-300 ohms), antenna transformer (300 ohms), switch box cable to adaptor, cassette ..... **\$995.00**  
 Model 212RO VCR only — No Accessories .. **\$849.00**

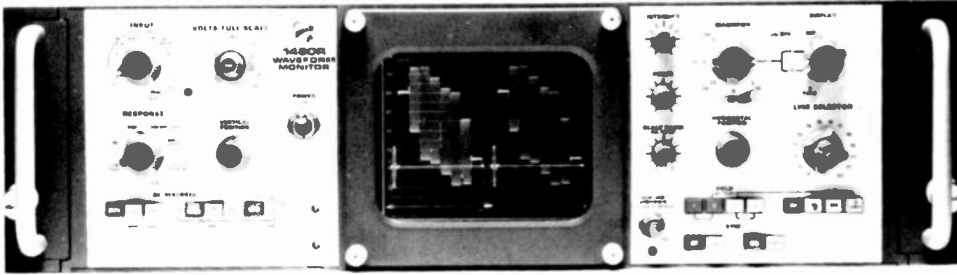

1485R Option 01 PAL/NTSC Dual Standard Waveform Monitor (Rackmount)

## 1480 Series

**Bright CRT Especially Suitable for Vertical Interval Testing**

**Advanced Measurement Modes**

**Amplitude Measurement Accuracy Approaching 0.2%**

**Digital Selection of Line and Field**

**Probe Input Option**

**15 Line Display for VTR Applications**

**The 1480 Series of Waveform Monitors.** There are 1480 Series Monitors for PAL, PAL-M, NTSC, and SECAM. Dual standard units are also available. The differences between the monitors in the series are essentially confined to what lines in the vertical interval are selectable, what vertical amplifier response modes are available, and to the field selection modes. Dual-Standard Monitors automatically recognize the signal standard in use and indicate that standard on the front panel.

**Vertical interval testing.** The bright CRT of the 1480 Series eliminates many of the VITS monitoring difficulties associated with previous waveform monitors. CRT brightness is sufficient to allow you to easily see one Vertical Interval Test Signal selected out of four fields, even in a well-lighted area. This solution to VITS display problems required the design of a very high light-output CRT, which is only one of the unique features of the 1480 Series.

**More accuracy, greater resolution.** The 1480s provide several advanced measurement modes for more accuracy. These allow you to make amplitude measurements to an accuracy approaching 0.2%. In one mode, a precision display offset is used. A proven video measurement technique, offsetting displays with an amplitude standard is an easy-to-use method that achieves accuracy by eliminating parallax and transfer errors. Transfer errors are eliminated because the signal is compared to a precise 1 V standard rather than to graticule calibration. Measurements made with comparison techniques also are highly consistent and repeatable. When the signal precisely matches the standard, signal amplitude will be determined to the value and accuracy of the offset. The tolerance of the internal calibration signal used as the standard is 0.2%.

**Sure line selection, positive field identification.** Digital selection of field and line assures positive identification of displayed information. For example, selection of line 18 of field 2 assures display of line 18, field 2. Digital techniques will not allow an incorrect selection.

**Response selection and a unique auxiliary mode.** Many television measurements require the filtering of some components from the composite signal. For example, luminance signal rejection by 3.58 MHz or 4.43 MHz subcarrier filters for differential gain measurements. A selection of appropriate filters is provided in the 1480s, including low pass, IRE, subcarrier, and one for staircase linearity measurements called differentiated staircase. When specialized or unique measurements require a special filter, you may insert that filter between the auxiliary video output and auxiliary input. The auxiliary video input mode, selected by the response control, allows you to add a filter or other device without breaking into the program line. The auxiliary video input and output are buffered by amplifiers to provide a precise 75  $\Omega$  source and load.

In the 1480 Series, monitor focus and brightness controls compensate for changes when switching from a two field setting to a faster time base and can easily be set to an optimum level.

The fastest sweep time is 0.1  $\mu$ s per division, fast enough and bright enough to examine T pulses. The 1480s are calibrated in  $\mu$ s with a basic 2% time base accuracy (3% when using the magnifier). X50 is the greatest range of magnification with steps of 10, 5, 2, and 1.

The sync recognizer has two modes: AFC and Direct. This provides a way to display jitter or to stabilize a jittery display.

## ORDERING INFORMATION

When ordering, please use the exact nomenclature given here.

<b>1480C NTSC Waveform Monitor</b> .....	<b>\$4840</b>
<b>1480R NTSC Waveform Monitor</b> .....	<b>\$4840</b>
<b>1481C PAL Waveform Monitor*</b> .....	<b>\$5035</b>
<b>1481R PAL Waveform Monitor*</b> .....	<b>\$5035</b>
<b>1482C PAL-M Waveform Monitor</b> .....	<b>\$5420</b>
<b>1482R PAL-M Waveform Monitor</b> .....	<b>\$5420</b>
<b>1485C PAL/NTSC Dual Standard Waveform Monitor*</b> .....	<b>\$5325</b>
<b>1485R PAL/NTSC Dual Standard Waveform Monitor*</b> .....	<b>\$5325</b>
Option 01 1 M $\Omega$ , 20 pF Probe Input (probe not included) .....	<b>Add \$245</b>
Suggested Probe P6108 10X Probe	
2 m order 010-6108-03, 3 m order 010-6108-05 .....	<b>\$90</b>
Option 02 With Carrying Case (Cabinet Version Only) .....	<b>\$115</b>
Option 03 With Blank CRT .....	<b>No Charge</b>
Option 04 Tone Wheel Sync (1480C, 1481C, 1482C, and 1485C only Replaces 529 or T04 in some RCA VTRs — Check with RCA for retrofit compatibility) .....	<b>Add \$665</b>
Option 05 Tone Wheel Sync (1485C only — check with RCA for retrofit compatibility) .....	<b>Add \$655</b>
Option 06 124 $\Omega$ WECO Style Inputs (1480R only) .....	<b>Add \$1660</b>
Option 07 Slow Sweep.** .....	<b>Add \$405</b>
Option 08 SECAM Field Identification (1481C, 1481R, 1485C and 1485R only) .....	<b>Add \$275</b>

\*1481C/R, 1485C/R meets European Broadcast Union Tech 3221-E. Guiding Principles for design of Television Waveform Monitors.

\*\* Option 07 satisfies EBU Tech 3221-E §3.2.2

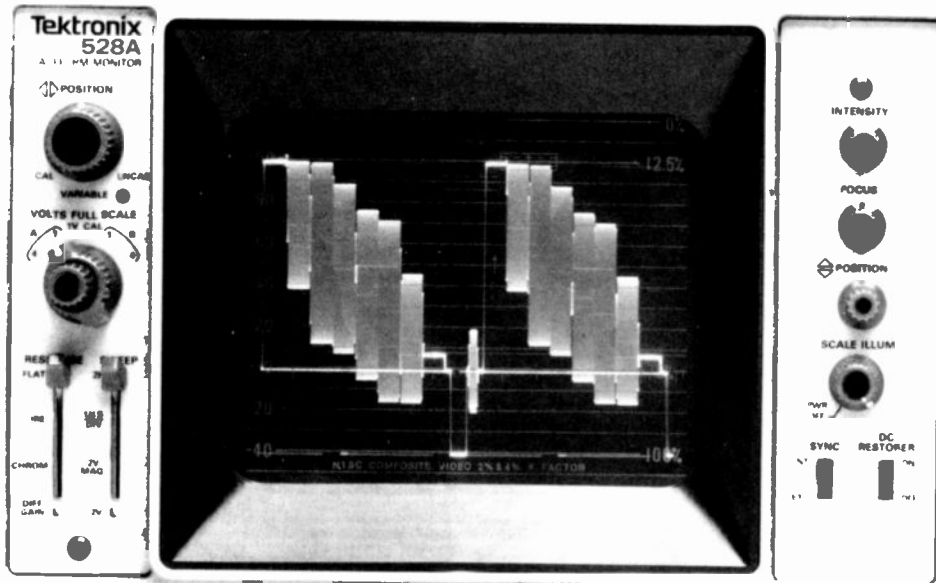

**NEW**

**528A**

**Internal Graticule CRT**

**Ac or Dc Input Coupling**

**Video Output of Displayed Signal**

**Precise Frequency Response**

**Line Tilt and Pulse Response (K Factor) Measurements**

**Different Versions for 525 or 625 Line Systems**

**UL 1244 Listed and Certified to CSA 556B**

The TEKTRONIX 528A Waveform Monitor is intended for television measurement and monitoring applications, adding new features and capabilities to the well known 528.

The 528A provides bright, easy-to-read waveform displays on a 125 mm (5 inch) CRT with illuminated internal graticule for parallax-free waveform monitoring and measurement while only requiring 5 1/4 inches of vertical height and 1/2 rack width mounting space. This permits mounting the 528A side-by-side with another 528A or other monitors, such as the TEKTRONIX 1420 Vectorscope. A version of the 528A in a carrying case is also available.

Selectable from the front panel, either of two 75-ohm video inputs may be displayed and the selected input is available on the rear panel VIDEO OUT connector for routing to a picture monitor or other device. These inputs are normally ac coupled, but are easily set for dc coupling.

Calibrated 1 volt and 4 volt full scale sensitivities are provided for displaying video and sync levels and a VARIABLE VOLTS FULL SCALE control permits uncalibrated displays from 0.25 volts to 4.0 volts full scale. A built-in 1 volt calibration signal may be switched on to confirm the vertical calibration.

Input signal characteristics can be isolated by using the RESPONSE switch in the FLAT position for full bandwidth display, IRE position for IEEE Standard 205 roll off display, CHROMA position for a display without luminance components, or DIFF GAIN position for displaying the differential gain error of the input signal. A dc restorer, which may be turned off when not required, maintains the back porch at an essentially constant level regardless of changes in signal amplitude, average picture level, and color burst. Selectable external sync capability is also provided.

Horizontal sweep selection includes: 2H (two line), 1  $\mu$ s (expanded two line), 2V (two fields) and 2V MAG (expanded two-field). Displays of RGB and YRGB waveforms from a color camera are provided for by using a rear panel 9-pin interface.

This compact instrument is especially suited for monitoring signals from studio camera outputs, video system inputs and outputs, production switchers, and editing consoles. The 528A allows the operator to adjust and monitor video and sync levels, check and adjust system timing, ensure continuity of the signal and perform camera alignment procedures. The 528A also meets many of the requirements of video tape recorder monitoring bridges for VTR alignment and set-up, differential gain measurements, line time tilt measurements, and pulse response (K factor) measurements. In general, the 528A is well-suited for all television applications where consistent video quality monitoring is a requirement.

### ORDERING INFORMATION

When ordering, please use the exact nomenclature given here.

<b>528A Waveform Monitor (for 525 line)</b> .....	<b>\$2175</b>
Option 01 Without cover .....	Sub \$30
Option 02 With blue protective carrying cabinet ..	Add \$65
Option 03 Modified for use with 625 line (CCIR) television systems and wired for use with 230 volt ac 50 Hertz power sources (unless otherwise specified) .....	No Charge

# TEK VECTORSCOPES

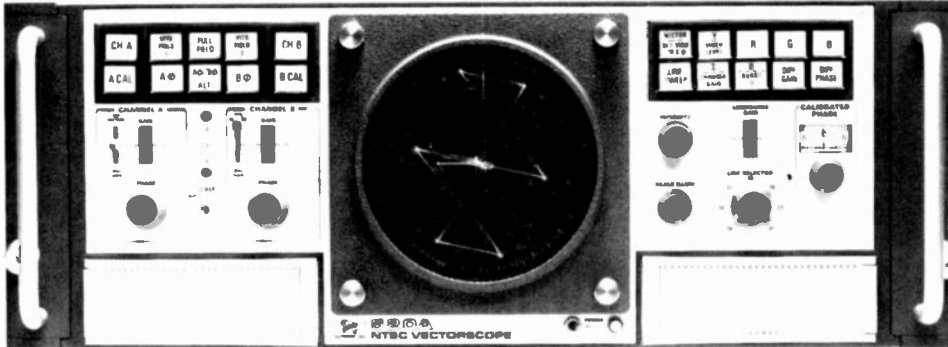

R520A NTSC (525/60 3.58 MHz) 520A (NTSC), 521A (PAL), AND 522A (PAL-M) VECTORSCOPES

## 520A Series

### Luminance Amplitude

### Chrominance Amplitude and Phase

### Differential Phase

### Differential Gain

The vector display shows the relative phase and amplitude of the chrominance signal on polar coordinates. To help identify these coordinates the graticule has points corresponding to the proper phase and amplitude of the primary and complementary colors R(Red), B(Blue), G(Green), Cy (Cyan), Y<sub>L</sub> (Yellow), and M<sub>G</sub> (Magenta).

Any errors in the color encoding, video-tape recording, or transmission processes which change these phase and/or amplitude relationships cause color errors in the television picture. Polar coordinate displays, such as those obtained on the 520A, 521A, and 522A CRT, have proved to be the best method for showing these errors.

The polar display permits measurement of hue in terms of relative phase of the chrominance signal with respect to the color burst. Amplitude is expressed in terms of the displacement from center (radial length) toward the color point which corresponds to 75% (or 100%) amplitude of the particular color being measured.

The outer boxes around the color points correspond to phase and amplitude error limits ( $\pm 10^\circ$ ,  $\pm 20\%$ ). For the 520A (NTSC) the inner boxes indicate  $\pm 2.5^\circ$  and 2.5 IRE units, of optimum per EIA specification RS-189A. For the 521A (PAL) and 522A (PAL-M), the inner boxes indicate  $\pm 3^\circ$  phase angle and  $\pm 5\%$  amplitude.

An internally generated test circle, used with the vector graticule, verifies quadrature accuracy, horizontal to vertical gain balance, and gain calibration for chrominance signal amplitude measurements. Two methods of measuring phase

shifts are provided. You can accurately read large phase shifts from the parallax-free vector graticule. A precision calibrated phase shifter with a range of  $30^\circ$ , spread over 30 inches of dial length, is provided for measuring small phase shifts.

**Dual Vector Displays.** In dual-channel operation, successive samples of channels A and B are displayed on a time-shared basis. The switching rate is locked to horizontal sync, and switching transients are blanked. You can conveniently compare input/output signals from video equipment on channel A or B for phase and/or amplitude distortion.

**Time Base Displays.** The linear time base operates at the line rate. Color signals may be demodulated along any desired axis, I, Q, and R-Y (for NTSC), and U, and V (for PAL and PAL-M), and displayed at the line rate on a linear time base.

**Red (R), Green (G), Blue (B), and Luminance (Y).** The 520A, 521A, and 522A provide a luminance channel that permits the separation and display of the luminance (Y) component from the composite color signal. You can also combine the Y component with the output of the chrominance demodulators for R, G, and B displays at a line rate. You can make amplitude measurements of color signal components with an accuracy of 3%.

**Vertical Interval Test Signal Observation.** You can display vertical interval test signals from front-panel selected lines of either field 1 or 2 on the 520A Vectorscope. For the 521A (PAL) and the 522A (PAL-M), you can display ITS from either fields 1 and 3 or fields 2 and 4.

**Differential Gain and Differential Phase Measurements.** The two main chrominance signal distortions — differential gain and differential phase — can be measured on the 520A (NTSC), 521A (PAL) and 522A (PAL-M) Vectorscopes. Differential gain is a change in color subcarrier amplitude as a function of luminance level. In the reproduced color picture, saturation will be distorted in the areas between the light and dark portions of the scene. Differential gain measurements with accuracy to better than 1% can be made.

Differential phase is a phase modulation of the chrominance signal caused by changes in the luminance signal level. The hue will vary with scene brightness in the reproduced color picture. Differential gain and differential phase occur separately or together. You can read differential phase errors from the precision calibrated phase shift control to  $0.2^\circ$ .

**Included Accessories** — Smoke-gray filter, installed (378-0581-00), power cord (161-0036-00). Rackmount. Same as cabinet but includes rackmounting hardware, and slide-out assembly.

## ORDERING INFORMATION

When ordering, please use the exact nomenclature given here.

<b>520A NTSC VECTORSCOPE</b>	
(Cabinet) .....	\$6675
<b>R520A NTSC VECTORSCOPE</b>	
(Rackmount) .....	\$6675
<b>521A PAL VECTORSCOPE</b>	
(Cabinet) .....	\$6940
<b>R521A PAL VECTORSCOPE</b>	
(Rackmount) .....	\$6940
<b>522A PAL-M VECTORSCOPE</b>	
(Cabinet) .....	\$7470
<b>R522A PAL-M VECTORSCOPE</b>	
(Rackmount) .....	\$7470

## OPTIONAL ACCESSORIES

**75  $\Omega$  Voltage Step-Up Termination** — When used with a Tektronix Vectorscope, the 75  $\Omega$  Voltage Step-up Termination provides a X5 increase in chrominance amplitude and lets you make more accurate Differential Gain and Differential Phase measurements. Input impedance to the termination is a constant 75  $\Omega$ . Use of the termination requires a source of external sync to the vectorscope.

For use with 520A (NTSC), 522A (PAL-M) Vectorscopes  
**BNC Connectors, order 011-0100-01** .....

For use with the 521A Vectorscope.  
**BNC Connectors, order 011-0109-00** .....

**\$85**

**Single Sideband Chroma Amplitude Corrector** — Designed for use with a Tektronix Vectorscope in transmitter applications where a vestigial sideband signal is being demodulated with a detecting diode. The corrector provides a X2 increase in chrominance amplitude and passes luminance components with little or no attenuation. Input impedance is 75  $\Omega$ .

For use with 520A (NTSC), 522A (PAL-M) Vectorscope:  
**BNC Connectors, order 011-0107-01** .....

For use with the 521A Vectorscope:  
**BNC Connectors, order 011-0108-01** .....

**\$105**  
**Recommended Camera** for display photographs. C-59P with Adapter 016-0295-01. See Camera section of this catalog for information.

**R520A Cradle Assembly** — For mounting the 520A in a WECO backless rack. **order 426-0667-00** .....

**\$33**

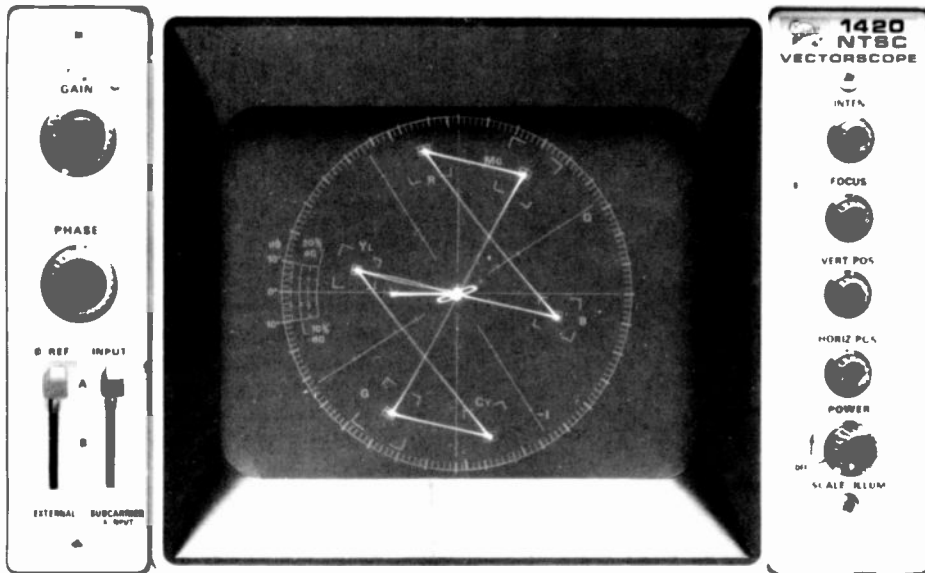

## 1420 Series

Half Rack Width

Two Loop-Through Inputs

Continuous 360° Phase Control

External Subcarrier Input

Illuminated Internal Graticule

X-Y Display Version

Each 1420 Series Vectorscope is a compact, half rack width instrument designed for vector display of the chrominance and burst components of the composite video signal. This series provides a low-cost way to meet basic vectorscope requirements in CCUs, VTRs, and similar applications. The 1420 is particularly well suited for side-by-side rackmounting with the TEKTRONIX 528A Waveform Monitor.

It weighs a little over 15 pounds with an optional carrying case.

The parallax-free internal graticule is designed for the vector display of color bars and burst. A special graticule feature allows you to determine gain or phase errors to reasonable accuracy for many applications—within 2° and 5% (for higher resolution differential gain and phase measurements use a 520A Series Vectorscope).

Two signal inputs, an external subcarrier reference input, and a PAL pulse input (1421 and 1422 only) are provided on the rear panel. The "A" signal input is equipped with a switchable attenuator, use it for viewing large signals such as the subcarrier signal. Select the signal to be displayed and the locking signal for the subcarrier regenerator with two front panel lever switches. On the 1421 and 1422, a push-pull switch lets you select the external subcarrier reference signal. All models have continuous 360° phase control of the displayed signal. PAL and PAL-M displays on the 1421 and 1422 are switchable to an NTSC format.

### 1424 X-Y DISPLAY MONITOR

The 1424 X-Y Display Monitor provides a vector display of the chroma portion of the television signal by utilizing the decoder in a TEKTRONIX 650HR Picture Monitor or other suitable monitor. By interfacing the 1424 with the proper picture monitor, vector displays for NTSC, PAL, and SECAM color television systems can be obtained. Dual standard displays can be obtained by interfacing the 1424 with a TEKTRONIX 655HR (NTSC & PAL) Picture Monitor or a 656HR (SECAM & PAL) Picture Monitor.

The Z-axis input allows the writing beam to be modulated for special applications.

### ORDERING INFORMATION

When ordering, please use the exact nomenclature given here.

**For NTSC, 1420 Vectorscope**  
(Factory Wired for 115 V) ..... \$2700

**For PAL, 1421 Vectorscope**  
(Factory Wired for 230 V) ..... \$2810

**For PAL-M, 1422 Vectorscope**  
(Factory Wired for 115 V) ..... \$3050

**1424 - Standard NTSC/PAL**  
**XYZ Display** ..... \$2335

**Rack Adapter**, (when ordering the vectorscope for use in the adapter, Option 01), 016-0115-02 ..... \$180

**Without Cabinet Option 01** ..... Sub \$30

**With Carrying Case Option 02** ..... Add \$65

**Option 03 (1424 only) — Special NTSC/PAL\***  
**XYZ display** ..... Add \$100

**Option 04 — (1424 only) External SECAM graticule, blank CRT** ..... Add \$100

**Option 05 — (1424 only) Combination NTSC/PAL\***  
**Internal graticule CRT** ..... Add \$100

\*For Ampex VTR's — check with Ampex for compatibility.



# TEK HIGH RESOLUTION 19 INCH COLOR MONITORS

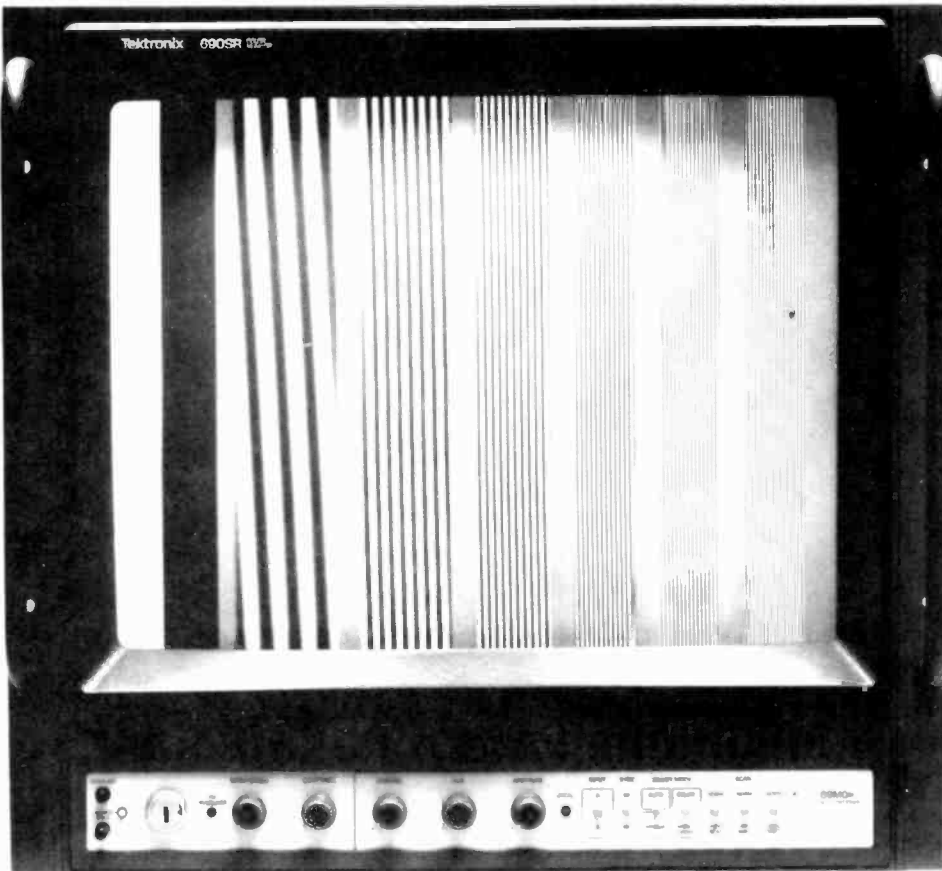

690SR Option 01

**NEW**

## 690SR Television Color Monitor

High-Resolution, Dot-Shadowmask CRT

Precise Color Convergence

Stabilized Color Balance

Rugged Construction

Preset Controls

Plug-in Decoder

Recommended for Critical Picture Evaluation

The 690SR is a new tool for the television industry to meet critical needs for picture evaluation and quality control. With a high resolution delta gun, dot shadowmask picture tube and precise, stable decoding circuitry, the 690SR offers faithful rendition of picture details and ease of closeup viewing. The optional medium resolution CRT provides uniform screen appearance and excellent resolution at greater viewing distances. With either picture tube, Tektronix unique color convergence system provides accurate color registration over the entire screen — less than 0.5 mm maximum error, equivalent to less than 0.18% of picture height — so that fine details can be observed anywhere in the picture.

Stabilized circuitry compensates for picture tube aging and maintains accurate color balance. Front panel controls for brightness, contrast, chroma, hue and aperture have detent positions so that the monitor may be returned to its preset condition quickly and accurately. Adjustments for the preset positions of front panel controls are located within a lockable front drawer together with virtually all other adjustments needed for routine servicing.

Decoders are available for NTSC and PAL standards. A flexible modular plug-in design permits the 690SR to accommodate changes in standards and additional modules will become available to meet future needs. Three systems are available at this time, comprising: the 690SR Option 01, which is an NTSC color monitor including a 69M00 notch filter decoder module installed in a 690SR mainframe; the 690SR Option 02\* which is an NTSC color monitor including a 69M01\* comb or notch filter (switchable from front panel) decoder module installed in a 690SR mainframe; and; the 690SR Option 11\*, which is a PAL color monitor including a 69M10\* decoder module installed in a 690SR mainframe.

All versions of the 690SR are available with a high resolution CRT (standard) with 0.31 mm dot triad spacing, or with a medium resolution CRT (Option 25) which has 0.43 mm dot triad spacing. EBU phosphor colorimetry is also available (Option 27)\*. All versions of the 690SR are supplied with rack slides for mounting in a 19 inch standard rack.

\*Available early in 1982

## 690SR Option 42 RGB Multirate Color Monitor

Scan Rates from 15 to 37.5 kHz

Adjustable Picture Size

Full Video Gray Scale

Flexible Interface

Modular Construction

High Performance for Television or  
Computer Graphics

Excellent Color Convergence over Entire  
Screen

The 690SR Option 42 has been designed to provide an accurate display of high quality images and computer graphics. Wide range scan circuits, excellent convergence and modular construction make the 690SR Option 42 an ideal choice for laboratory experiments and for systems where easy reconfiguration to different scan formats will make it possible for one monitor to do many jobs.

The 690SR Option 42 will operate over a horizontal scan rate range of 15 to 37.5 kHz, covering the range from standard television formats to above the 1280 by 1024 pixel format used for high resolution graphics. With the additional feature of adjustable picture size and aspect ratio, the 690SR Option 42 can be used for displays in unconventional formats. Excellent color convergence — less than 0.5 mm maximum error anywhere on the screen — is maintained over the entire rate range with only slight readjustment of controls.

The high resolution picture tube (0.31 mm dot triad spacing) is standard with all versions of the 690SR; however, a medium resolution CRT (0.43 mm spacing) is available as Option 25. Long persistence phosphors for flicker reduction in interlaced graphics displays is Option 26.

The 690SR Option 42 is an RGB monitor including a 69M41 interface module installed in a 690SR mainframe. Either internal sync on green or external sync may be used. The 690SR Option 42 is supplied with hardware for rack mounting.

### ORDERING INFORMATION

<b>690SR Television Color</b>	
<b>Monitor Mainframe</b> .....	<b>\$7950</b>
Option 01 NTSC Interface Installed .....	Add \$1100
Option 25 Medium Resolution CRT .....	Sub \$250
Option 26 Long Persistence Phosphors (High Resolution only) .....	Add \$150
Option 42 Multirate RGB Interface Installed .....	Add \$2000
<b>69M00 NTSC Decoder</b>	
<b>Interface Module</b> .....	<b>\$1100</b>
<b>69M41 RGB Interface Module</b> .....	<b>\$1000</b>

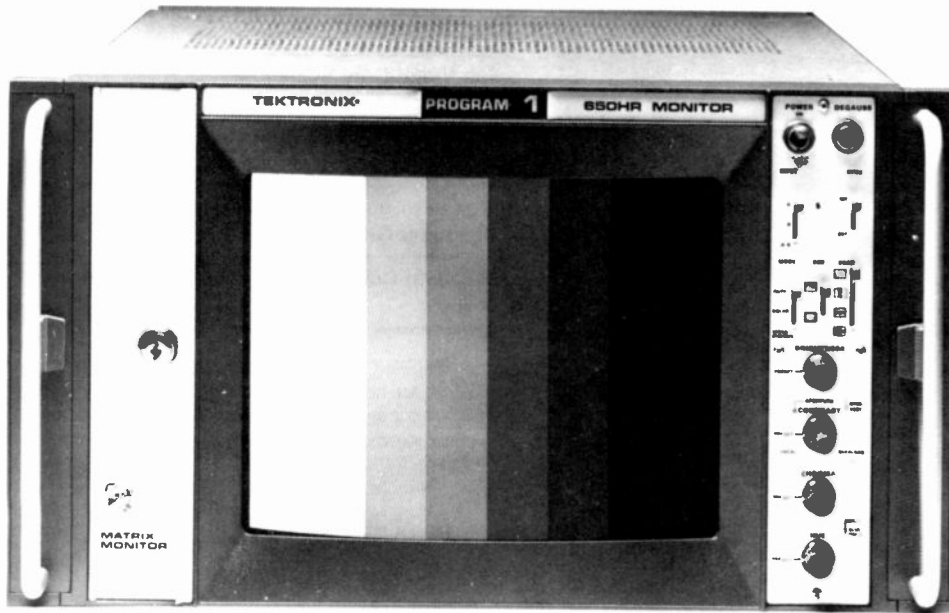

### 650HR Series NTSC, PAL Color Picture Monitors

Precise Color Tracking Over Full Signal Range

Two Switchable Inputs Isolated from Ground for Hum Rejection

External Sync Switching Capability

Differential (A-B) Inputs for Sync Timing and Burst Phasing Adjustments

High Resolution Trinitron CRT

Variable Aperture Correction

NTSC, PAL, and Dual Standard Versions — RGB Inputs Optional

Rapid Retrace — Entire Active Picture Area can be Displayed in Underscan

Precision Decoding — Outputs may be used to Present Vector Displays on X-Y Oscilloscopes

Unique "Blue Only" Capability for Optimizing VTR Settings

#### ORDERING INFORMATION

When ordering, please use the exact nomenclature given here. All 650HR Monitors are shipped with rackmounting hardware. Cabinet version hardware is also included.

650HR NTSC .....	\$5350
650HR-1 NTSC + RGB .....	\$5545
651HR PAL .....	\$5580
651HR-1 PAL + RGB .....	\$5810
655HR NTSC + PAL .....	\$6125
655HR-1 NTSC + PAL + RGB .....	\$6365

Accurate vector displays on X-Y oscilloscopes such as the TEKTRONIX 1424 are made possible by the precision decoder outputs on TEKTRONIX 650HR Series Monitors

#### Color Picture Monitors — NTSC, PAL, SECAM, RGB

In addition to having stable, consistent color characteristics, Tektronix Color Picture Monitors provide underscan and vertical and horizontal delay for detailed examination of the entire picture. A special high resolution Trinitron CRT and adjustable aperture correction provide consistently high picture sharpness. Isolated differential inputs for encoded/composite or RGB signals, flexible synchronization and unique Blue Only mode permit the 650HR Series Monitor to meet a variety of needs — both in television systems for displaying and monitoring television picture quality and in special systems where a laboratory quality display is required.

### 650HR Series SECAM Color Picture Monitors

Color Sequencing from Field Identification Signals or Line Burst

Precision Decoding Allows use of R-Y, B-Y Outputs for Vector Display Measurements

PAL/SECAM Version Available (656HR) with Front Panel Selection of Decoding Standard

RGB Inputs (Optional) Includes R-Y, B-Y Output

Variable Aperture Correction

Vertical and Horizontal Delay Display Modes

Reduced Chrominance Line Crawl

Indicates Color Sequence Error

Rapid Retrace — Entire Picture Area is Displayed in Reduced Scan

Two Switchable Inputs Isolated from Ground for Hum Rejection

#### ORDERING INFORMATION

When ordering, please use the exact nomenclature given here.

653HR SECAM MONITOR .....	\$6355
653HR-1 SECAM + RGB .....	\$6570
656HR SECAM + PAL .....	\$6980
656HR-1 SECAM + PAL + RGB .....	\$7190
Option 01 MiniQuick Connectors for 653HR, 656HR .....	Add \$130
Option 01 MiniQuick Connectors for 653HR-1, 656HR-1 .....	Add \$195



# PROFESSIONAL COMMUNICATIONS HEADSETS AND STEREO HEADPHONES



LW-1



HD-4



CS-81



CS-83



CS-85



CS-91



CS-87



CS-7



1325

## HEADPHONES AND HEADSETS

Model	Order By Catalog No.	Description	Price
<b>SPORTSCASTER HEADSETS (w/Press-to-Cough switch)</b>			
CS-91	63620-000	Dynamic, dual, 6000 ohm Mic Omni Dynamic 50/250 ohm	\$165.00
LW-1	63650-000	Magnetic, single, 3000 ohm Mic Omni Dynamic 150 ohm Battery included	170.00
HD-4	63700-007	Dynamic, dual 600 ohm Mic Noise Cancelling Electret .150 ohm Battery included	165.00
<b>CAMERAMAN'S HEADSETS (All unterminated and with Carbon or Carbon equivalent mic. 20/50 ohm)</b>			
TS-200	63750-000	Magnetic single 275 ohm Mic	133.00
CS-81	63300-003	Magnetic single 275 ohm Mic	104.50
CS-83	63300-002	Magnetic single w/PTT switch, 275 ohm Mic	115.50
CS-85	63300-001	Magnetic dual 275 left, 625 right Mic	170.00
CS-87	63300-000	Magnetic dual w/PTT switch, 275 left, 625 right Mic	187.50
<b>HEADPHONES (No Microphone)</b>			
CS-7	61320-005	Monaural, Dynamic dual 600 ohm	77.00
1325	61325-002	Stereo Dynamic dual 600 ohm	95.00

# TROMPETER ELECTRONICS INC.

## Standard Coax Patching Systems

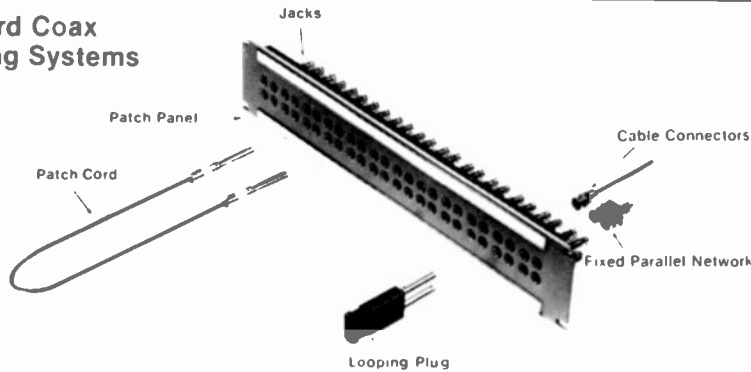
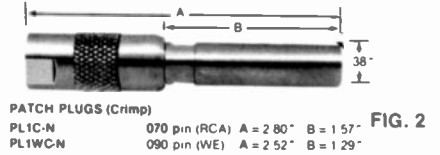
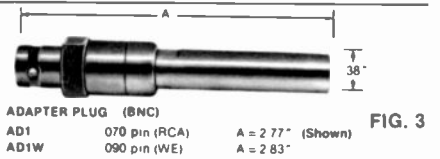

FIG. 1

## Plugs & Cable Assemblies



**PATCH PLUGS (Crimp)**  
 PL1C-N 070 pin (RCA) A = 2.80" B = 1.57"  
 PL1WC-N 090 pin (WE) A = 2.52" B = 1.29" **FIG. 2**



**ADAPTER PLUG (BNC)**  
 AD1 070 pin (RCA) A = 2.77" (Shown)  
 AD1W 090 pin (WE) A = 2.83" **FIG. 3**

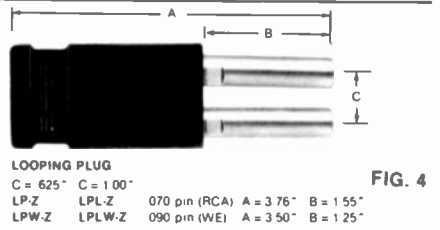

**LOOPING PLUG**  
 C = 625" C = 100"  
 LP-Z 070 pin (RCA) A = 3.76" B = 1.55"  
 LPW-Z 090 pin (WE) A = 3.50" B = 1.25" **FIG. 4**

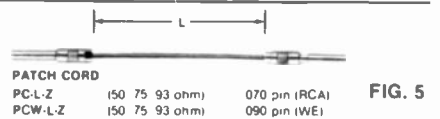

**PATCH CORD**  
 PC-L-Z (50 75 93 ohm) 070 pin (RCA)  
 PCW-L-Z (50 75 93 ohm) 090 pin (WE) **FIG. 5**

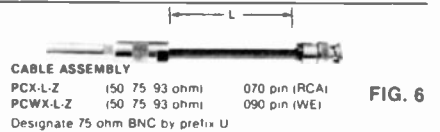

**CABLE ASSEMBLY**  
 PCX-L-Z (50 75 93 ohm) 070 pin (RCA)  
 PCWX-L-Z (50 75 93 ohm) 090 pin (WE) **FIG. 6**  
 Designate 75 ohm BNC by prefix U

**Cable Assemblies Ordering Information:**

Assembly Model PC-L-Z

Standard Length in Inches \_\_\_\_\_  
 (6, 12, 18, 24 or 36)

Impedance (Ohms) \_\_\_\_\_ (50,75,93)

## Jacks: Single/Dual

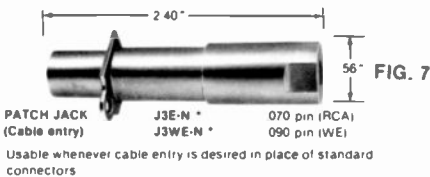

**PATCH JACK (Cable entry)** J3E-N \* J3WE-N \* 070 pin (RCA) 090 pin (WE) **FIG. 7**  
 Usable whenever cable entry is desired in place of standard connectors

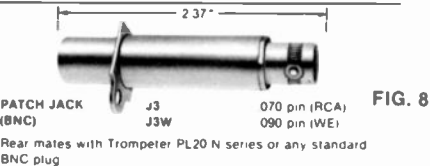

**PATCH JACK (BNC)** J3 J3W 070 pin (RCA) 090 pin (WE) **FIG. 8**  
 Rear mates with Trompeter PL20 N series or any standard BNC plug

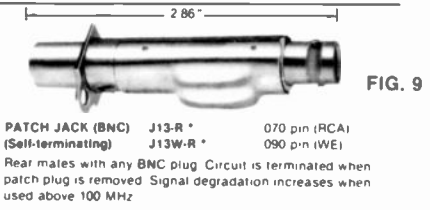

**PATCH JACK (BNC) (Self-terminating)** J13-R \* J13W-R \* 070 pin (RCA) 090 pin (WE) **FIG. 9**  
 Rear mates with any BNC plug. Circuit is terminated when patch plug is removed. Signal degradation increases when used above 100 MHz

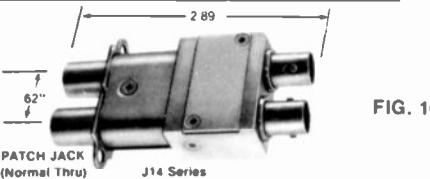

**PATCH JACK (Normal Thru)** J14 Series **FIG. 10**

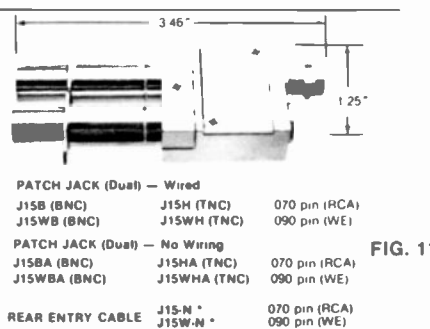

**PATCH JACK (Dual) - Wired** J15B (BNC) J15H (TNC) 070 pin (RCA) J15WB (BNC) J15WH (TNC) 090 pin (WE) **FIG. 11**  
**PATCH JACK (Dual) - No Wiring** J15BA (BNC) J15HA (TNC) 070 pin (RCA) J15WBA (BNC) J15WHA (TNC) 090 pin (WE)  
**REAR ENTRY CABLE** J15-N \* J15W-N \* 070 pin (RCA) 090 pin (WE)

## Introduction:

Trompeter Electronic's standard coax patching systems, shown on this page, provide limitless flexibility to route signals from one place to another. Two basic versions of Standard Coax patching are available. The RCA 50 ohm with a pin size of .070" and the Western Electric (WE) 75 ohm type with a pin size of .090". The two are not interchangeable but can be intermixed on the same panel along with TEI's audio patch jacks and panel lites (not shown)

PART NO	FUNCTION		REAR ENTRY	PIC FIG	CIRCUIT FIG
	RCA	WESTERN ELECTRIC			
J3E N	J3WE N	Patch Jack Single	Cable*	7	-
J3	J3W	Patch Jack Single	BNC Standard TNC Available	8	-
J3D	J3WD	Patch Jack Single	Solder Pot	Not Shown	-
J13R **	J13WR	Patch Jack Single - Self Terminating	BNC Standard TNC Available	9	17
J13C R **	J13WC R	Patch Jack Single - Self Terminating	Cable* Crimped	Not Shown	17
J14 Series	J14W Series	Patch Jack Dual - Self Looping	Dual BNC Standard TNC Available	10	12 thru 16
J15 Series	J15W Series	Patch Jack Dual - Rewired Parallel or No Wiring	Single - BNC TNC or Cable*	11	-

\* Typical Cable - RG 58 54 12, 174 and 223  
 \*\* Substitute Resistance for H A 5%

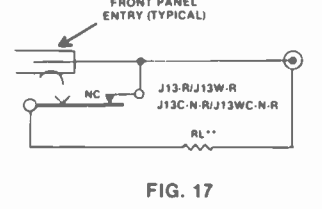
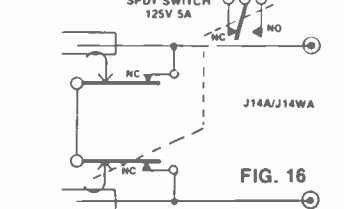
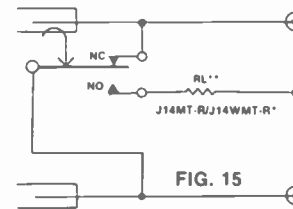
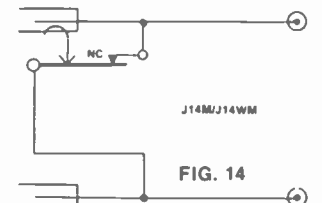
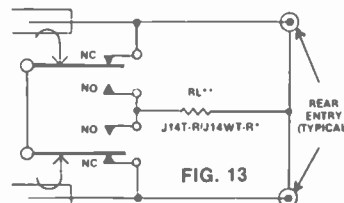
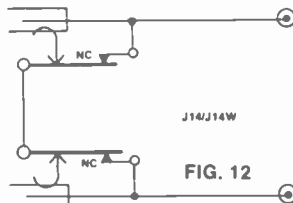

## Patch Panels

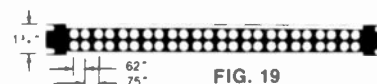

PANEL HEIGHT	NO. OF ROWS	FIG.	PANEL DESIGNATION AND NO. OF SINGLE JACKS ACCOMMODATED														
			12	14	16	20	24S	26	28	32S	36	40S	48S	52S			
1 3/4"	1	18															
	2	19															
3 1/2"	2	20															

Will not accept J14 or J15 Dual Jack  
 Full Line Catalog and Pricing Available on Request Prices and Specifications Subject to Change Without Notice

## Ordering Information:

**JSI - 12 / J3W**

Panel Type \_\_\_\_\_  
 (JS = Aluminum)  
 (JSI = Insulated)

No. of Jack Holes \_\_\_\_\_

Jack Type \_\_\_\_\_  
 To Order Panels Only, Leave "Jack Type" Blank.

## 25 G TOWER

### ROHN NO. 25G TOWER

General Purpose Communication or Heavy-Duty TV Tower. The 25G will satisfy a tremendously wide range of tower needs.

Built on a 12½" equilateral triangular design with continuous steel "zig-zag" cross-bracing entirely electric welded and fabricated in precision equipment. The 8 "zig-zag" braces per 10' section mean more than usual strength.

#### CONSTRUCTION

Unequalled Sturdiness . . . Extra heavy-duty 1¼" steel tubing is used for side rails, resulting in far greater strength and sturdiness than ordinarily found in this size tower. SUPERIOR STRENGTH.

#### FINISH

Famous ROHN Hot-Dip Galvanized long-life finish.

#### SPECIAL FEATURES

The No. 25G uses double-bolted joints . . . proven the best method of joining tower sections for sturdiness and dependability. The extra strength of the No. 25G allows it to be self-supporting provided a house bracket is used and can go 35 feet above this bracket under normal conditions (see instruction sheet). Under most guyed conditions the No. 25G is suitable to heights of 200 feet! Where special conditions or unusual antenna loading requirements must be met, we suggest you contact the Engineering Department for complete information. *Assembly bolts and nuts are located within 1 leg of each tower section.*

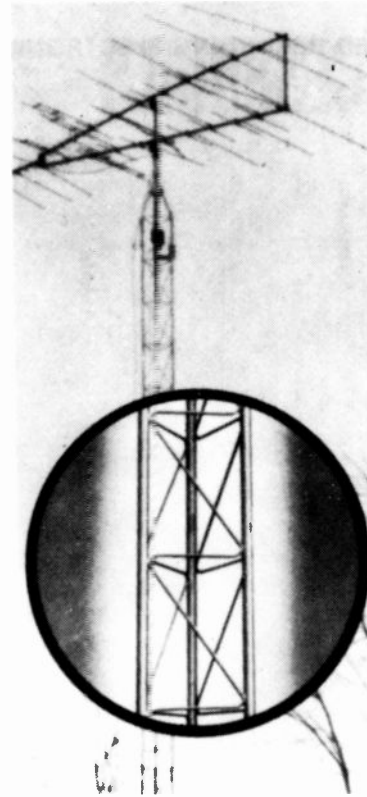

#### SELF-SUPPORTING HEIGHTS FOR 25G TOWER\*

WIND LOAD	Factor of Safety—1.5		Factor of Safety—2.3	
	No. Ant.	2 Ft.?	No. Ant.	2 Ft.?
10.0 PSF (50 MPH)	72.4'	64.8'	58.4'	50.9'
14.4 PSF (60 MPH)	60.4'	52.9'	48.7'	41.3'
20.0 PSF (70.7 MPH)	51.3'	43.8'	41.4'	34.1'***

\*See Installation Instruction

\*\*Recommended

PART NUMBER	WT.		
25G	10'	40	GB25G Guy bracket only 6
25AG	9'	31	HB25AG Adjustable house bracket (0 to 15'') 8
ST25AG	5'	18	HB25BG Adjustable house bracket (0 to 24'') 11
25AG1	Top section for use with communication antenna. Mast support tube is 1¼" galv. pipe, threaded on top and projecting 12" above apex of side rails.	31	HB25CG Adjustable house bracket (0 to 36'') 17
25AG2	Top section for use with communication antenna. Mast support tube is 2¼" O.D. tubing, 36" total length, extending 18" above apex of side rails	31	HBU Universal house bracket (6" to 30'') 15
25AG3	Top section for use with communication antenna. Mast support tube is 2¼" O.D. tubing, extending 12" above apex of side rails. A 2" O.D. antenna stub will fit snugly inside support tube.	31	EB2515G Eave bracket (15'') 4
25AG4	8' top section for use with communication antenna. Upper end terminates in 11" dia. flat, circular plate with 2¼" dia. hole in center	31	EB2524G Eave bracket (24'') 6
25AG5	Top section for use with communication antenna. Mast support tube is 2¼" O.D. and 2-9/16" I.D. tubing, 18" total length.	31	EB2525G Eave bracket (universal) 7
25TG	10' tapered base section	60	TB50 Tower bushing for 25AG and ST25AG tops (1¼" I.D. x 2" O.D.) ½
*25RG	10' insulator section for 25G tower (includes three #10470 post insulators)	74	TB75 Tower bushing for 25AG and ST25AG tops (1½" I.D. x 2" O.D.) ½
25ACL	10' anti-climb section (for #25 and #20 towers)	115	AB Amateur bearing for use with 25AG4 top (2" x 4" x 10" hardware) 1
25ACL3	3' anti-climb metal sheets for attaching to tower section	65	TB3 Heavy duty thrust bearing, recommended for 2" O.D. tubing 2½
25JBK	Joint bolt kit	½	BPL25G (Disc) Top plate with guy lugs for mounting AB or TB3 bearing 7
APL25G	Beacon plate	1/2	BAS25G Bearing/accessory shelf section for mounting AB or TB3 bearing and rotor 18
SB25G	3'4" short base section for concrete	10	UHF25G Side arm mount for UHF and FM antennas 4
SB25G5	5' short base section for concrete	20	SAB25G2 Side arm bracket for top antenna mounting alongside beacon (2½" O.D. tubing, 36" total length) 15
*SBH25G	3'4" hinged short base section for concrete	14	SA25G224 24" side arm with 36", 2¼" O.D. support tube 22
*HGB25G	3' hinged ground base (for use without concrete)	27	SA25G524 24" side arm with 18", 2-9/16" I.D. support tube 18
*SDB25G	Single drive base	20	SA25G67 67" side arm with 1¼" I.D. support tube for mounting TV receiving antenna (not recommended and must be guyed to resist twist) 25
*BPC25G	Concrete base plate	27	TA25 Torque arm stabilizer assembly 35
¼X12PPP	Pier pin (for BPC25G or 25TG—one required)	1	25TDM2 Top dish mount w/2" O.D. mast (extends 2' above top plate) 34
*BPH25G	Hinged base plate for concrete	21	25TDM2SP Top dish mount w/2" standard pipe (extends 3' above top plate) 44
¼X12BB	Concrete base bolt with double nuts (for BPH25G—four required)	½	25TDM2EH Top dish mount w/2" EH pipe (extends 3' above top plate) 53
*FR25G	Flat roof mount	24	25TDM25SP Top dish mount w/2½" standard pipe (extends 3' above top plate) 58
*PR25G	Peak roof mount	14	DM25G2 Face dish mount w/2" (2¼" O.D.) 5' long standard pipe 42
*BP25G	Base plate (for use with drive rods)	7	WP25G Work platform (for #25 and #20 towers) 10
*DR25G	3'4" drive rods (set of 3)	8	SR245 Safety ring 8
DT25	Drive tool	1	EF2545 Aluminum erection fixture, 12' long (fits all models with 1¼" side rails) 18
RP25G	Rotor post	3	P2545 Pole only for EF2545 10
RP25GCM	Rotor post	2	H2545 Head only for EF2545 8
AS25G	Accessory shelf Triangular plate for mounting Ham "M" rotor or mast bearing. Mounts inside of tower. When using Model 400 Rotor, plate must be redrilled.	4	
GA25G	Guy assembly (bracket with torque bars)	10	

\*Towers mounted on these bases must be bracketed or guyed

#### PART NUMBER

25G030BRKT	30' Complete Bracketed Tower
25G040BRKT	40' Complete Bracketed Tower
25G050BRKT	50' Complete Bracketed Tower
25G060BRKT	60' Complete Bracketed Tower
25G070BRKT	70' Complete Bracketed Tower
25G080BRKT	80' Complete Bracketed Tower

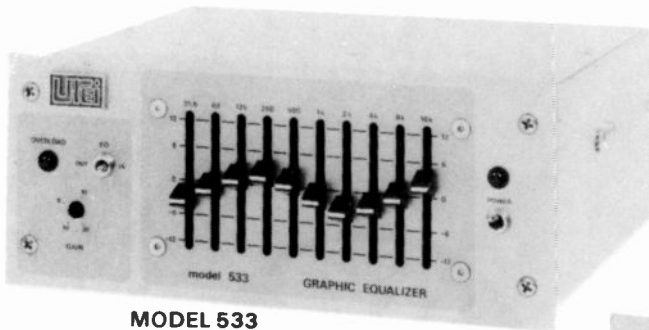

**MODEL 533**

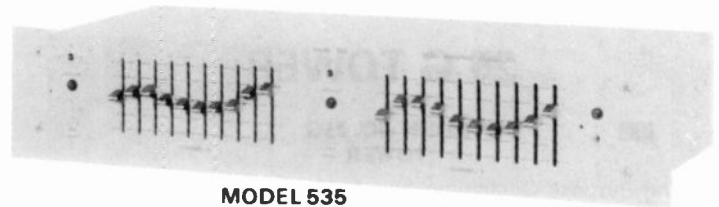

**MODEL 535**

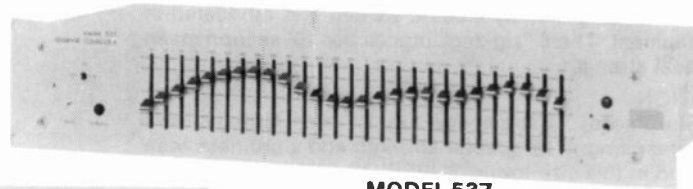

**MODEL 537**

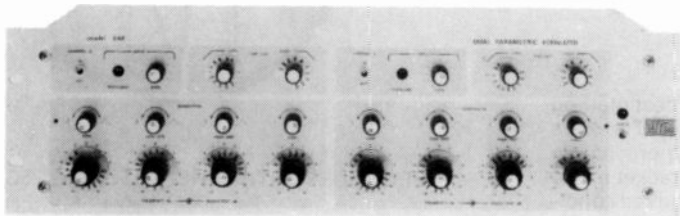

**MODEL 546**

**533 Octave Graphic Equalizer**

The 533 Octave Graphic Equalizer is a studio quality product which has wide application in recording, sound reinforcement, radio and TV production, and high fidelity music systems. It is a successor to the popular UREI Model 532 offering 10 filter sections with increased control range, and more output capability.

**Model 535 Dual Graphic Equalizer**

- Two channels in one compact package
- 10 adjustable equalizers on ISO one-octave center frequencies for each channel
- 12 dB boost or 12 dB attenuation at each center frequency
- Stepless, noiseless, calibrated controls
- Gain variable from - 10 dB to + 20 dB
- State of the art synthesized LC filter circuitry
- Low distortion, lowest noise, minimum phase shift
- Standard rack mounting, only 3½ inches high
- Optional front panel security cover
- Competitively priced
- UREI quality of course

**Model 537 1/3 Octave Graphic Equalizer**

- 27 adjustable equalizers on ISO 1/3-octave center frequencies
- 12 dB boost or 12 dB attenuation at each center frequency
- Stepless, noiseless controls, precision calibrated
- State-of-the-art active L-C filter circuitry
- Low distortion, lowest noise, minimum phase shift
- Zero insertion loss, up to 20 dB gain
- Standard rack mounting, only 3½ inches high
- Optional front panel security cover
- Competitively priced
- UREI quality of course

**Model 546 Dual Parametric Equalizer**

- Two independent channels in one package
- Four sections of Parametric Equalization in each channel all continuously variable in Bandwidth, Frequency, and Boost and Cut
- Bypass switches for both channels and each parametric filter section
- Expanded Single Channel mode provides eight sections of parametric equalization
- End cut filters tunable over a wide range for bandwidth restriction
- Large, easy-to-adjust controls
- Multi-point overload detection circuits
- Balanced or unbalanced bridging inputs
- Transformer isolated outputs
- Gain variable over a 30 dB range
- UREI quality, of course

**Equalizers and Filters**

501	Sub-Sonic Processor	88.00
525	Electronic Crossover	696.00
	SC2 Security cover for 525	36.00
533	Octave Graphic Equalizer (mono)	296.00
	DR-1 Double Rack Mount for two 533's	24.00
	SR-1 Single Rack Mount for one 533	26.00
535	Dual Graphic Equalizer	496.00
	SC1 Security cover for 535	36.00
537	1/3-Octave Graphic Equalizer	846.00
	SC1 Security cover for 537	36.00
539	Room Equalizer	996.00
	SC1 Security cover for 539	36.00
545	Parametric Equalizer	396.00
546	Dual Parametric Equalizer	696.00
	SC4 Security cover for 546	48.00
562	Feedback Suppressor	546.00
	SC3 Security cover for 562	36.00
567	PA Processing System	846.00
	SC2 Security cover for 567	36.00

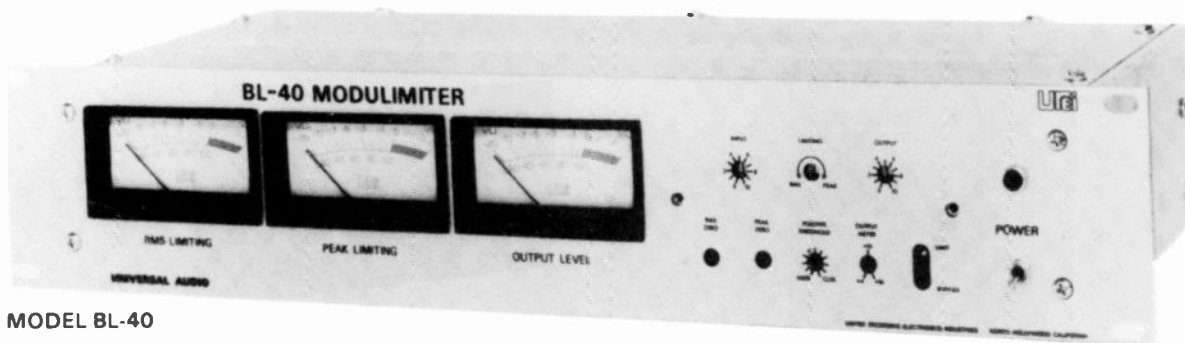

**MODEL BL-40**

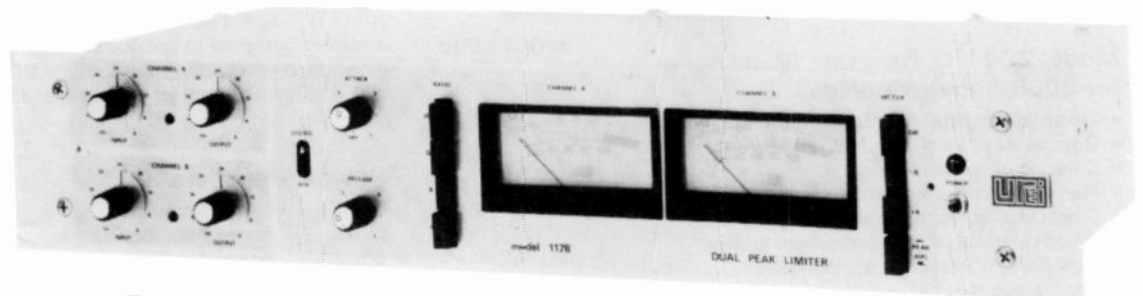

**MODEL 1178**

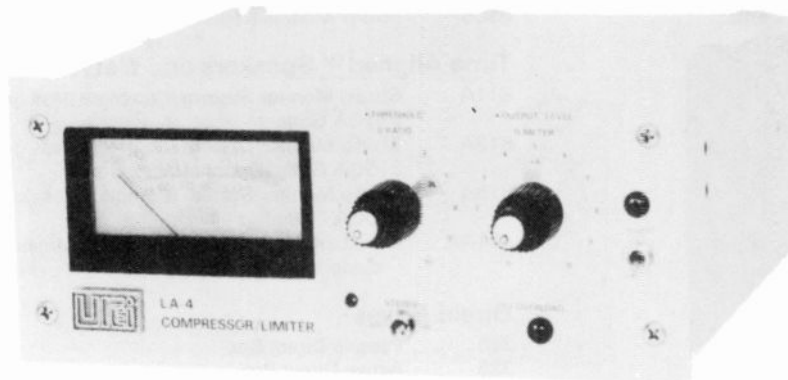

**MODEL LA-4**

**BL-40 Modulimiter**

The BL-40 Modulimiter is specifically designed for AM broadcasting, but will also find wide application in TV and CCTV audio signal processing, background music systems and commercial sound systems.

For the AM broadcaster, Modulimiter eliminates unwanted overmodulation without clipping. Independent adjustments are provided for RMS and peak limiting, and variable positive overmodulation up to 125%.

Modulimiter features low noise, low distortion integrated circuitry, and occupies only 3½" of rack space. Three separate meters indicate RMS LIMITING, PEAK LIMITING and OUTPUT LEVEL simultaneously.

**LA-4 Compressor/Limiter**

The LA-4 Compressor/Limiter is another great performer in the continually expanding product line from UREI — the company which has built and sold more limiters and compressors throughout the world than any other manufacturer. Making use of patented Electro-Optical Attenuator technology owned by UREI, the LA-4 offers smooth, predictable performance coupled with ease of operation. Its electroluminescent light source is a light-emitting semiconductor, which will not change or deteriorate with age.

**Model 1178 Dual Peak Limiter**

- Two independent Peak Limiters with perfect tracking when used in stereo mode
- Attack time front panel adjustable from 20-800 micro-seconds. Independent of peak duration or frequency
- Release time front panel adjustable from 50 ms to 1.1 seconds
- Pushbutton selection of four compression ratios, to satisfy various program requirements
- High impedance, balanced, bridging inputs
- Balanced, transformer outputs
- Low noise, low distortion
- Switchable meter ballistics (VU, peak)
- UREI quality, of course

**Limiters and Compressors**

LA-4	Compressor/Limiter	<b>\$446.00</b>
	DR-1 Double Rack Mount for two LA-4's	<b>24.00</b>
	SR-1 Single Rack Mount for one LA-4	<b>26.00</b>
1176LN	Peak Limiter	<b>546.00</b>
	SC2 Security cover for 1176LN	<b>36.00</b>
	1176SA Stereo Adaptor	<b>46.00</b>
1178	Dual Peak Limiter	<b>796.00</b>
	SC2 Security cover for 1178	<b>36.00</b>
BL-40	Modulimiter	<b>596.00</b>
	T4C Electro-Optical Attenuator (replacement for BL-40)	<b>48.00</b>

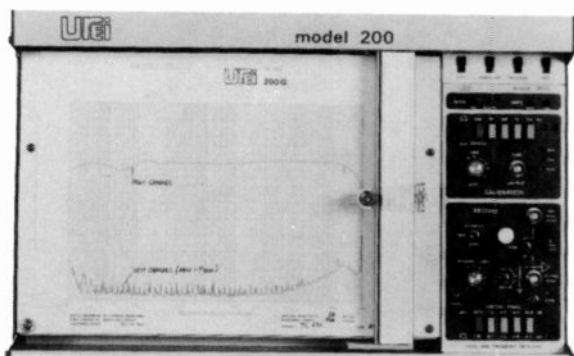

**MODEL 200**

**Model 200 X-Y Recorder Mainframe for 2000 Series Modules**

- Electrostatic paper holddown alignment guides
- Disposable pens or standard felt tip pens
- Desk top or rack mounting
- Plug-in versatility with modular electronics
- Single chassis rugged casting
- Switch selectable universal power facility
- Pen, Servo, Chart and Line switches
- Continuous duty servo motors



**MODEL 811A**

**Model 811A Time Aligned Studio Monitor System**

- The 811A uses a newly developed\* high frequency horn utilizing UREI's Diffraction Buffer plus other new techniques. This results in smoother response, extended H.F. range, and improved off-axis response
- Provides a reduction in transient distortion
- The new 800H-A H.F. horn incorporates many unique features which afford improved matching of the horn driver throat to free air and substantially reduce the "Shadow Effect" common to some coaxial type loudspeakers. In addition, other acoustic techniques have been employed to significantly reduce transient distortion (ringing). These features improve the combining of the low and high frequency drivers in a smooth time and magnitude relationship
- Low loss crossover network allows maximum power transfer to the transducers and corrects the spatial alignment of acoustic centers
- BNC connector on the crossover network allows use of Conductor Compensation as available on the UREI Model 6500 Power Amplifier. This reduces the reactive effects of the speaker cable and improves damping
- 604 ceramic duplex with UREI custom H.F. horn for extended and more uniform H.F. response
- Size is ideal for small control rooms, broadcast or mastering rooms, and audition rooms
- <5 cu. ft. enclosure with pressure control aperture for excellent L.F. damping good efficiency and low distortion
- Unique enclosure damping method provides high efficiency conversion of low frequency sound pressure to adiabatic energy

\*Patent pending



**MODEL 1122**

**1122 Stereo Transcription Preamp**

The 1122 is a two-channel, solid-state, equalized preamplifier/line amplifier designed to provide the highest quality disc reproduction for broadcast and recording applications. While primarily intended for stereo use, it may be utilized for two separate monophonic channels.

**Power Amplifiers**

6150	Power Amplifier	\$596.00
6250	Power Amplifier	796.00
6300	Power Amplifier	1296.00
6500	Power Amplifier	2196.00
6505	Power Module (replacement module for 6500)	846.00

**Time Aligned™ Speakers and Networks**

811A	Studio Monitor System (Complete, less grille)	\$1276.00
	811GA Grille	48.00
813A	Studio Monitor System (Complete, less grille)	1776.00
	813GA Grille (Optional Accessory)	52.00
815A	Studio Monitor System (Complete, less grille)	1996.00
	815GA Grille	62.00
801AA	Altec Lansing/UREI 8 ohm coaxial driver with custom 800HA horn	696.00

**Direct Boxes**

315	Passive Direct Box	126.00
325	Active Direct Box	198.00

**Specialty Items**

200	X-Y Recorder Mainframe	\$1996.00
201	Display Interface Mainframe	696.00
2000	Frequency Response Plug-in Module	1846.00
2010	Level and Frequency Detector Plug-in Module	1946.00
2020	DC Input Module	346.00
	20 Warble Generator (Accessory for 2000)	126.00
	21 Warble Generator/Mic Preamplifier (Accessory for 2000)	296.00
	200G Graph Paper (100 sheets)	16.20
950	ANCA (Ambient Noise Controller Amplifier)	1146.00
964	Digital Metronome	696.00
	DR-2 Double Rack Mount for two 964's	24.00
	SR-2 Single Rack Mount for one 964	26.00
1122	Stereo Transcription Preamplifier	366.00

**Accessories**

301	XLR/QG Adaptor (For models LA4, 535, 537, 539 525, 1178, 1176LN)	26.00
40-0022	2½" Modutec "A" Scale VU Meter w/Bezel	26.00
40-0026	2½" Modutec "A" Scale VU Meter w/Bezel Backlit	30.00
PS24-2	Power Supply	376.00
T4B	Electro-Optical Attenuator (replacement for LA3A and LA2A)	48.00
527SC	Security Cover (silver panel only)	36.00
529	Security Cover (silver panel only)	36.00
530	Security Cover (silver panel only)	36.00
537	Security Cover (silver panel only)	36.00
539	Security Cover (silver panel only)	36.00



# VICON INDUSTRIES INC.

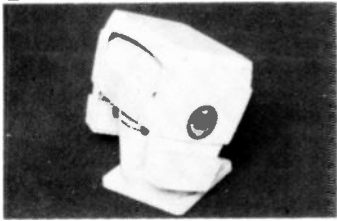

## PAN AND TILT UNITS

Pan and Tilt units are devices for remote positioning of cameras in both the horizontal and vertical planes. Vicon offers a complete line of pan and tilt units for light, medium, and heavy-duty applications, in both indoor and outdoor models. Units are available in either fixed or variable speed versions.



## OMNISCAN

Omniscan units are discreet enclosures for camera/lens systems offered in spherical, hemispherical, and flat envelopes. They house pan and tilt, scanning, and fixed camera systems. For indoor applications, they are intended to assure a pleasing appearance and minimum camera visibility.



## SCANNERS

Scanners rotate in the horizontal plane only. Camera tilt position is manually adjustable. Offered in light and medium-duty indoor versions and heavy-duty outdoor versions, these units provide an oscillating sweep surveillance of a selected area.

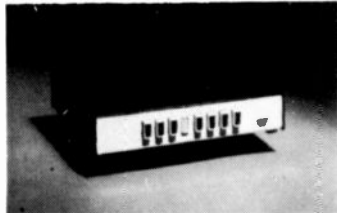

## SWITCHERS (MANUAL)

Manual video switchers are offered in non-illuminated pushbutton, status indicator, (mechanical flag position indication) and illuminated pushbutton versions, either terminated or looping. Models are available for switching from four to sixteen camera inputs. All switchers are available in desktop or rack-mounted versions.

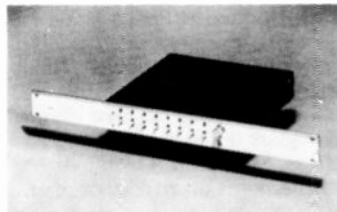

## SWITCHERS (AUTO)

Automatic video switchers cycle camera positions at selected rates. These switchers (manual, alarm programmed, and broadcast level routing) are offered as either single or dual package models, in homing, bridging, looping, and looping-bridging versions. Dual switchers feature local control and remote switching, hardwired and FSK modulated. Routing switchers are microprocessor controlled versatile matrix systems.

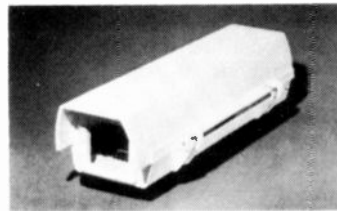

## HOUSINGS

Vicon offers a wide range of both indoor and outdoor housings and enclosures including theftproof, tamper-proof, concealed, maximum security, explosion-proof, dust-proof, and pressurized models in a variety of sizes to fit each and every application. Add-on's for housings include heaters, blowers, wipers, washers, and a variety of other special accessories.

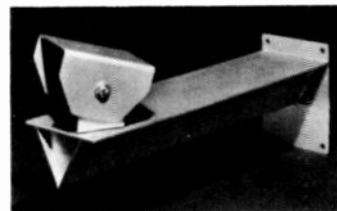

## MOUNTINGS

Vicon mounting accessories include adjustable and fixed support for cameras both indoor and outdoor housings, scanners, pan and tilt units, and video-monitors. Mounting is possible from all horizontal and vertical surfaces on most Vicon units. Models intended for industrial use and/or decorator installation comprise a comprehensive line to fit all usual mounting requirements.

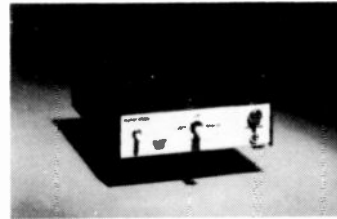

## CONTROLS (SINGLE)

Vicon controls are offered in both desktop and standard 19" rack panel configurations for the remote operation of pan and tilt units, scanners, lenses, enclosures, and infrared illuminators. Each control has been designed to operate a specific product and to form a compatible combination with other controls in the formulation of a complete system — both operationally and aesthetically.

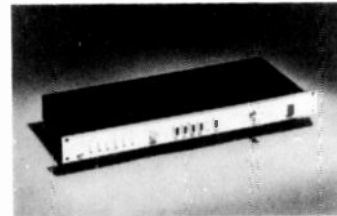

## CONTROLS (MULTIPLE)

In order to conserve panel or desktop space, Vicon offers several multiple control units for operating remote equipment such as pan and tilts, scanners, and zoom lenses. Multiple control units are either dual station, which operate remote units from two locations, or single station, which operate several remote units from a single control location.

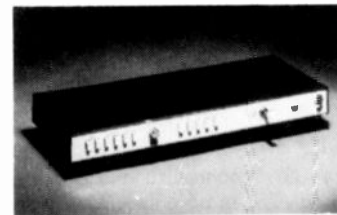

## CONTROLS (DIGITAL)

Vicon's digital control systems include long-distance pulse modulated and VPS 1200™ controls, and medium distance Modupulse™ and Vicoax™ coaxial cable control systems. These units are intended for medium to large system remote control utilizing either twisted control cable or video coaxial cable as a medium for control signals for the purpose of simplifying cabling requirements. Vicon Model VPS 1200™ is a microprocessor based programmable system for flexible control of larger installations.

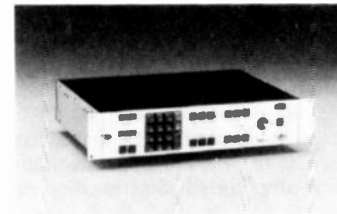

## CONTROLS (MICROPROCESSOR BASED)

Vicon's microprocessor based programmable systems include the VPS 1200™ control with digital transmission over a dual shielded twisted pair and the VPS 1300 R.F.™ system with modulated control and video signal transmission over single coaxial cables. These systems offer half duplex transmission and continuous receiver polling for flexible control of larger installations.

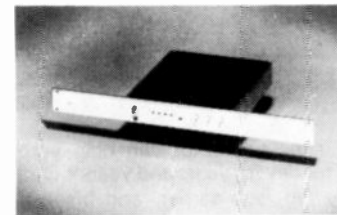

## VIDEO SIGNAL EQUIP.

Video signal equipment encompasses a wide range of video related products. This specialized equipment includes video amplifiers, distribution amplifiers, motion detectors, time/date generators, screen splitters, camera identifiers, and many others.



## FIXED LENSES

Vicon's fixed focal length lenses include manual, motorized, motorized with Intraspot™, auto-iris variations of electric eye and various other specialized types. Vicon's automatic lenses are compatible with virtually all existing cameras. A wide range of focal lengths and lens speeds are available for both one inch and two-third inch vicon formats.



## ZOOM LENSES

Vicon offers a comprehensive range of zoom lenses in a variety of focal lengths and speeds. Zoom lenses for both one inch and two-third inch vicon formats are offered in manual, motorized, motorized with Intraspot™ filter, auto-iris with Intraspot™ filter, and in various other unique configurations. Vicon offers control systems for all motorized and automatic lenses, as well as compatible auto-iris control in conjunction with cameras now offered by most manufacturers.



VS-1

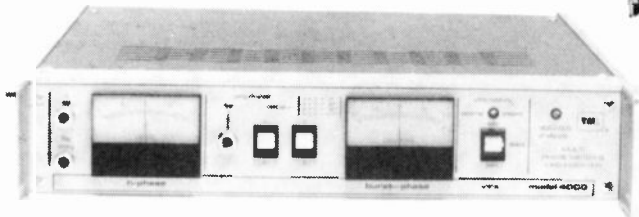
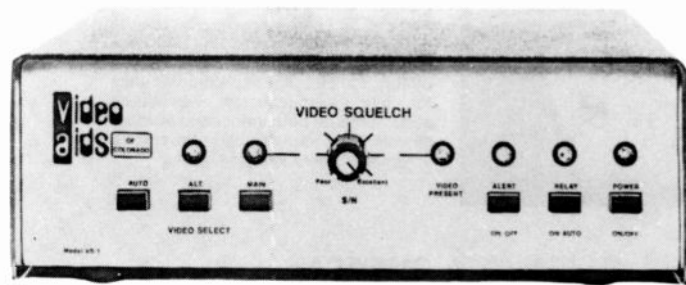

Multi-Phase Meter and VIRS Inserter

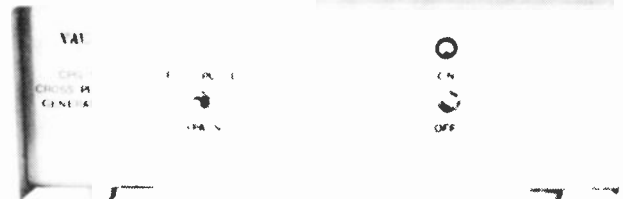

Cross Pulse Generator

### Color Genlock Sync Generator

VACC's genlock provision allows you to synchronize your entire video system to an external video source (VTR, remote line, etc.) • Auto/Internal reference switch • Indicator lights (power, phase lock, external sync present) • Sub-carrier phase adjustment (coarse and fine) • NTSC stability long term • Phase lock • Outputs H drive, V drive, blanking, burst flag, sub-carrier, black burst and dual sync outputs • Inputs loop-thru composite video or black burst.

Helical tape recorder outputs have typically 1000 or more times the frequency variations of broadcast video. The Model 5000 OPT: 01 provides a very wide range genlock that is front panel selected to lock to helical recorder playbacks even with +/-1% speed variations, +/-10 microseconds skew and high amplitude head transition noise.

Model 5000 ..... \$1995.00

### NTSC/RS170 COLOR SYNC GENERATOR

Model 100 ..... \$ 835.00

Model 100R (Rack) ..... 890.00

Model 100DA (Cabinet with DA) (220 VAC) ..... 995.00

Model 100RDA (Rack with DA) ..... 1050.00

VACC's Model 100 NTSC color sync generator can help you get technically-correct pictures day after day for years and years • Outputs H-drive, V-drive, blanking, burst flag, sub-carrier, and black burst • NTSC stability long term.

### Multi-Phase Meter and VIRS Inserter

VACC's Model 4000 Multi-phase meter/VIRS inserter is both a production tool and engineers' instrument. It can be substituted for a vectorscope when measuring VIRS-phase and Burst-phase errors. The Model 4000 is an ideal replacement for most oscilloscopes where H-phase errors need to be observed and measured. Both Burst-phase and H-phase can be measured simultaneously on easy-to-read, lighted analog meters. Production personnel, technicians and engineers alike find the Burst-phase and H-phase meter easier to use, five times more accurate and one-fifth the cost of traditional equipment.

Besides the capability of measuring VIRS-phase, Burst-phase and H-phase, VACC's Model 4000 allows you to add VIRS to line 19 of each television field. The principle purpose of the VIR signal is to monitor the amplitude phase parameters of TV material being transmitted. It can also be used to monitor equipment performance in a video system. For example, when inserted into all final video, the VIR signals can be a great benefit for equalize and adjust videotapes during playback.

Model 4000 Multi-Phase Meter and VIRS Inserter ..... \$1790.00

### Video Squelch

Model VS-1 ..... \$695.00

The Video Squelch is an automatic video fault monitor and signal switch. By use of a unique circuit scheme, this unit monitors a main video feed for signal-to-noise ratio degradation below a customer set level or for complete loss of valid video signal. If either fault occurs, an alternate video source is selected and built-in visual and audible alarms operated. An automatic 110 volt switched power source is provided to control auxiliary equipment when a fault occurs. The VS-1 is ideal for unattended control of remote repeaters, automatic alternate best feed selection in cable and satellite distribution systems, and continuous signal monitoring at broadcast stations and in industrial installations.

### Color Burst Phase Meter

Model BPM-1 (Cabinet) ..... \$695.00

Model BPM-1R (Rack) ..... 745.00

Model BPM-1 OPT: 02 H-phase ..... 855.00

Model BPM-1 OPT: 03 (Rack with dual meters) ..... 990.00

VACC's BPM-1 option: 02 Burst Phase Meter and H Phase Meter is both a low-cost substitute or replacement for most vectorscope applications where burst-phase errors need to be observed and measured. Likewise, the unit is a low-cost substitute for an oscilloscope where H-Phase errors need to be observed and measured. H-Phase adjustments are necessary during post-editing on VTR's and on video equipment such as cameras and time base correctors. When making H-Phase measurements on an oscilloscope, it is very common to encounter display shifts due to differences in DC restoration. The H-Phase meter eliminates this ambiguity. Technicians and engineers alike find the burst-phase and H-Phase meter easier to use, more accurate and convenient and one-fifth the cost of traditional equipment. The BPM's small size and low-cost find this instrument ideal for their recording room, TV studio and remote van.

### Cross Pulse Generator

Model CPG-1 ..... \$325.00

Model CPG-1R (Rack) ..... 380.00

Model CPG-1 OPT: 01 (External Sync) ..... 355.00

Model CPG-1R with OPT:01 ..... 410.00

VACC's Model CPG-1 Cross Pulse Generator BNC loop-thru connects in any video line (unity gain). Operates externally with any monitor without modification.

Checks helical tape playback skew error allowing for correction while making duplicate tapes.

Check helical switching head noise and line-to-line jitter.

Checks QUAD head tape playback errors.

Checks type of sync being used and errors such as clipping, overshoot, ringing, jitter and improper equalizing and serration pulses. Provides a valuable tool in troubleshooting and adjusting many types of video equipment.

**ELECTRO OPTICAL ISOLATOR**

Model A-1 (For Sony KV1201, 1203, 1204, 1212, 1214, 1215, 1500, 1503, 1510, 1511, 1530, 1710 & CKV-171) ..... **\$190.00**  
 Model A1-A (For Sony KV1711, 1711D, 1712D, 1722, 1723D, 1910, 1910D, 1920, 1920D, 2101) ..... **\$190.00**  
 Model 800 (For Sony KV1206, 1217, 1221R, 1514, 1543R, 1545R, 1546R, 1714, 1715R, 1743R, 1746R, 1912, 1913, 1914, 1923, 1943R, 1944R, 1945R, 1946R, 2145R, 2601, 2643R, 2644R, 2645R, and KP5020, 7220)  
 Model 810 (For Sony KV1207, 1515, 2602, 2647R) ..... **\$190.00**

Installing a V.A.C.C. model A-1 optical isolator circuit in your Sony Trinitron™ color receiver converts it for use as a high quality color monitor while still retaining the receiver function. Installation takes less than one hour by an experienced electronics technician. The kit includes one printed circuit board and mounting hardware. When using a hot chassis receiver as a monitor it is necessary to use heavy isolation transformers and circuitry which adds to the weight, size and cost of the receiver/monitor. To eliminate these disadvantages, V.A.C.C. uses the latest in technology—electro optical isolators. The devices use light emitting diodes and photo transistors to transmit video and audio information over light beams to the hot chassis circuit of the set.

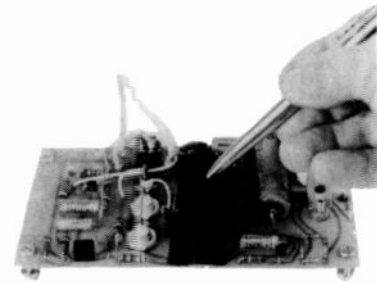

**Model A1 and A-1A for converting receivers into receiver/monitors.**

**GENERAL PURPOSE VIDEO LINE ISOLATOR**

Model VL-1 ..... **\$270.00**  
 VACC's Video Line Isolator improves overall performance of your video system by providing better power-line isolation (80 dB) than traditional differential amplifiers. Common-mode ground loop problems are reduced between in-coming video signals and different AC power ground potentials. A neon indicator on the self-contained model VL-1 indicates dangerous ground potential voltages.

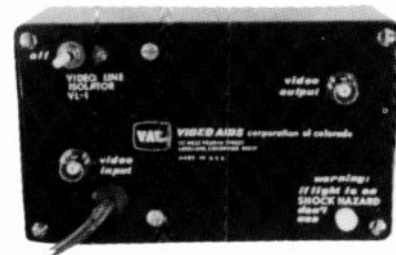

**Model VL-1 for general purpose isolation of video lines.**

**PARTY LINE (INTERCOM)**

PL-1 (Single Unit) ..... **\$ 65.00**  
 PL-1 BC (Party Line Unit with Belt Clip) ..... **68.00**  
 PLS-1 (Master Unit) ..... **100.00**  
 VACC's Party Line System is an Intercom Amplifier for use with low-impedance headset and carbon microphone (i.e. W.E. type and Telex CS-78). A system would consist of one master (PLS-1) unit and several (up to ten per Master) PL-1 units. The PL-1 Unit may be used without the PLS-1 Master if 8 to 12V well-filtered DC neg. ground is available. Interconnection is 3-wire, shielded twin lead (Belfoil). Using shield for ground is excellent. The talk circuit is not affected by gain control on each unit.



**VIDEO ACTIVATED POWER SWITCH**

Model VPS-1 ..... **\$79.00**  
 VACC Model VPS-1 Video Activated Power switch provides easy remote control of AC power to any video monitor. Only six wires need to be connected internally in a video monitor; one wire to the video input connector, one wire to ground, two wires to the AC input of the monitor and two wires to the AC power cord in the monitor. The video switch is self-contained on one small 3" x 3 3/4" printed circuit board for easy mechanical and electrical installation by a video technician or engineer.

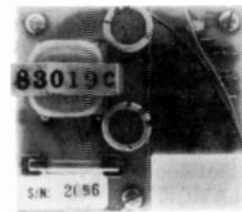

**Black Burst Generator Kit**

**Black Burst Generator Kit**

Model BBG-1 ..... **\$99.00**  
 VACC's Model BBG-1 Black Burst Generator Kit provides easy addition of black burst to any NTSC color sync generator. Only eight wires connected to the sync generator's outputs and +5 volt power supply makes electrical connection fast and easy to do. The generator kit is self-contained on one small printed circuit board for easy mechanical installation. Typical installation by a video technician or engineer is less than 30 minutes. Inputs — Subcarrier, burst flag, comp. sync, comp. blanking, +5 VDC.

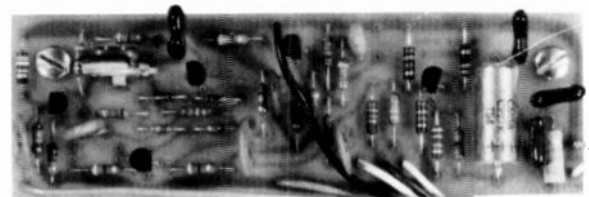

### TSM-5 A WAVEFORM MONITOR

### VSM-5 A VECTORSCOPE

# THE PERFECT COMPANIONS

Professional Test Equipment for the accurate monitoring and measurement of television waveforms and vector signals.

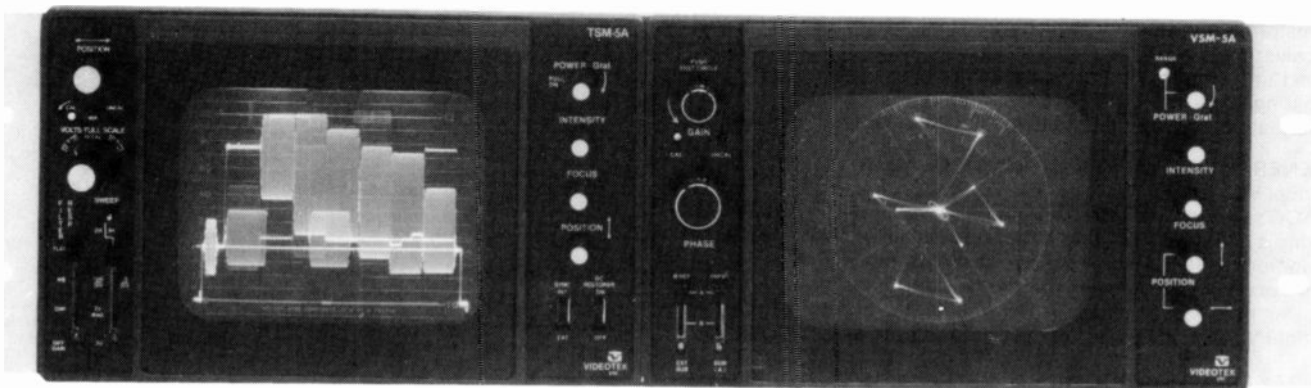

#### FEATURES

- ✓ INTERNAL ILLUMINATED GRATICULE - With pulse-bar measurement capability for parallax free measurements.
- ✓ TIME BASE - 2H, 1H, 1 $\mu$ s/DIV, 0.5 $\mu$ s/DIV, 2V, 2V MAG.
- ✓ FILTERS - Flat, IRE (per IEEE 205 Std.), Chroma, Differential Gain.
- ✓ INPUTS - Selectable A/B video looping BNC inputs.
- ✓ OUTPUTS - Separately buffered video out 1VP-P into 75 ohm termination.
- ✓ SYNC - Selectable internal/external input.
- ✓ YRGB/RGB - 9 pin access connector for monitoring color processing amplifier waveforms.
- ✓ DC RESTORATION - Selectable
- ✓ HIGH VOLTAGE REGULATION
- ✓ 100% SOLID STATE CIRCUITRY
- ✓ NTSC/PAL - Standard NTSC 525 lines, 30 frame (60 Hz field rate) scan (or) PAL 626 lines, 25 frame (50 Hz field rate) scan.
- ✓ COMPACT - Mounts in 5 1/4" of vertical rack space and one-half 19" rack width space.

#### TSM-5 A

Waveform Monitor without case .....	\$1965.00
Options:	
Single Standard Case .....	30.00
Portable case w/handle and sunshield .....	118.00
Double rackmount case .....	200.00
Blank panel .....	20.00
Dimensions: 5 1/4" (13.3 cm) H x 8 1/2" (21.6 cm) W x 18 1/2" (47.0 cm) D	
Weight: 15 lbs.	

#### FEATURES

- ✓ INTERNAL ILLUMINATED GRATICULE - For parallax free measurements.
- ✓ INPUTS - Selectable A/B video, looping BNC inputs and subcarrier "A" select. PAL pulse looping BNC inputs (PAL only).
- ✓  $\emptyset$ REF - Selectable A/B / Calibrate subcarrier and external subcarrier looping inputs.
- ✓ TEST - NTSC: Test circle/alternate line push button. selectable, PAL: Test circle/NTSC push button selectable.
- ✓ HIGH VOLTAGE REGULATION.
- ✓ 100% SOLID STATE CIRCUITRY.
- ✓ NTSC/PAL - Standard NTSC 525 lines, 30 frame (60 Hz field rate) scan, 3.579545 MHz subcarrier frequency (or) PAL 625 lines, 25 frame (50 Hz field rate) scan, 4.433618 MHz subcarrier frequency.

#### VSM-5A

Vectorscope without case .....	\$2365.00
Options:	
Single Standard Case .....	30.00
Portable case w/handle and sunshield .....	118.00
Double rackmount case .....	200.00
Blank panel .....	20.00
Dimensions: 5 1/4" (13.3 cm) H x 8 1/2" (21.6 cm) W x 18 1/2" (47.0 cm) D	
Weight: 13 lbs.	

### AC/DC CCTV COLOR MONITORS

The choice is yours. A series of four monitors and monitor/receivers is available in five inch and eight inch sizes for any and all EFP and ENG applications. This durable and light-weight series of color monitors takes the guess work out of setting up color cameras and taping color programming on remote locations. They are also ideal for use with all editing systems.

#### VM-5A AC/DC

Five Inch Color Monitor  
Dimensions 10-5/8" H x 6-3/8" W x 13" D  
Weight 11 Lbs 4 Ozs  
Price: \$899.00

#### RM-5A AC/DC

Five Inch Color Receiver/Monitor  
Dimensions 6-5/8" H x 8-7/8" W x 12-3/8" D  
Weight 13 Lbs 4 Ozs  
Price: \$929.00

#### VM-8A AC/DC

Eight Inch Color Monitor  
Dimensions 9-3/8" H x 10-1/4" W x 12-7/8" D  
Weight 17 Lbs 3 Ozs  
Price: \$899.00

#### RM-8A AC/DC

Eight Inch Color Receiver/Monitor  
Dimensions 9-5/8" H x 11-3/4" W x 2-3/8" D  
Weight 19 Lbs 3 Ozs  
Price: \$957.00

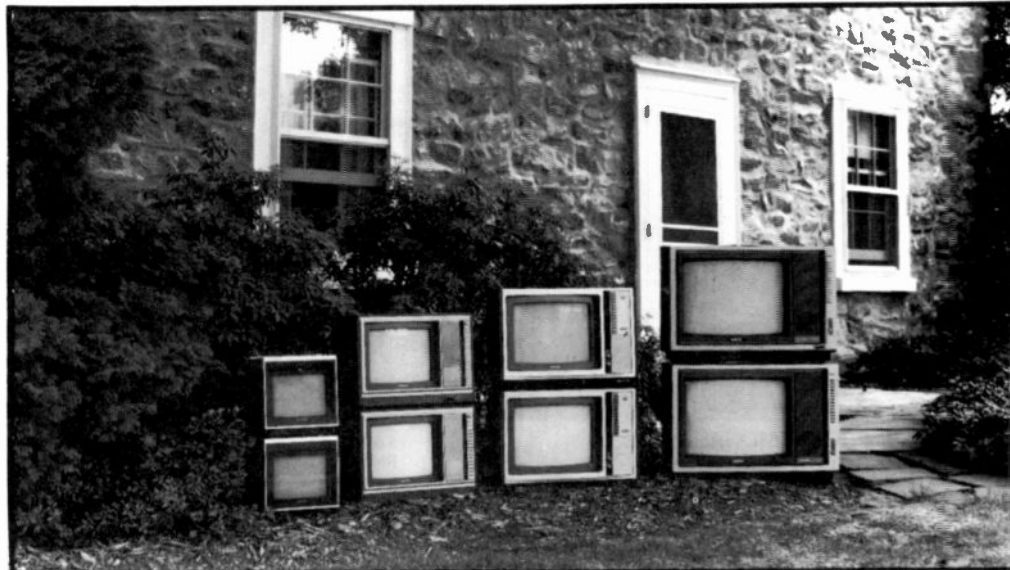
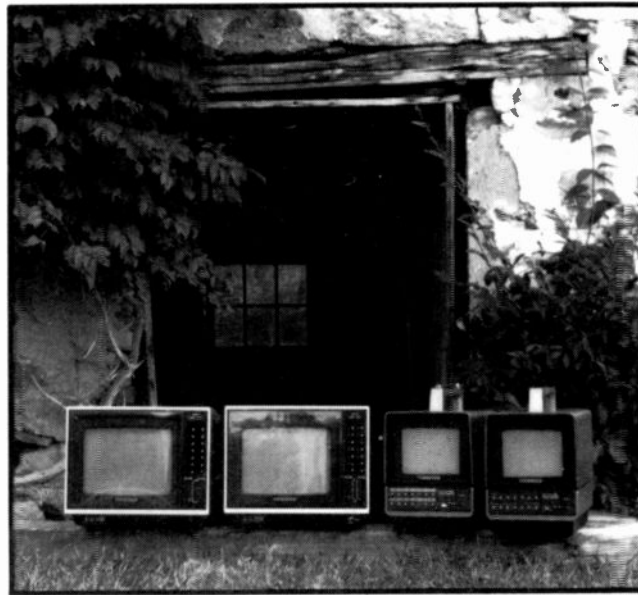

Videotek Trinitron Plus® color monitors and monitor/receivers are designed for use in closed circuit, cable and teleproduction application. Optional equipment is available, making the entire series most versatile and desirable for broadcast use. All of the monitors and monitor/receivers are totally compatible with portable recording equipment, one hundred percent solid state circuitry, complemented by the Trinitron Plus® CRT assures maximum stability and reliability of all Videotek color monitors.

STANDARD FEATURES ON ALL UNITS: DC Restoration, 8 Pin VTR Connector, Audio

OPTIONS AVAILABLE A-B Selection (not available with TV-Line-VTR Selection), Blue Gun, External Sync, Underscan, Pulse Cross, TV-Line-VTR Selection (not available with A-B Inputs) Standard on RM-8, 12, 15, 17, 19 and 26

#### VM-9A

Nine Inch  
Dimensions 11 1/4" H x 10 1/2" W x 13 1/8" D  
Weight 16 Lbs 5 Ozs  
Price \$957.00

#### RM-9A

Nine Inch  
Dimensions 11 1/4" H x 10 1/2" W x 13 1/8" D  
Weight 18 Lbs 5 Ozs  
Price \$929.00

#### VM-12

Twelve Inch  
Dimensions 13 3/8" H x 18 1/2" W x 15 3/8" D  
Weight 32 Lbs  
Price \$947.00

#### RM-12

Twelve Inch  
Dimensions 13 3/8" H x 18 1/2" W x 15 3/8" D  
Weight 34 Lbs  
Price \$855.00

#### VM-12RA

Twelve Inch Rackmount  
Dimensions 14" H x 18 1/8" W x 15" D  
Weight 32 Lbs  
Price: \$957.00

#### RM-12RA

Twelve Inch Rackmount  
Dimensions 14" H x 18 1/8" W x 15" D  
Weight 34 Lbs  
Price: \$1045.00

#### RM-13

Thirteen Inch Receiver Monitor  
Dimensions 18 7" W x 13 8" H x 15" D  
Weight 35 lbs  
Price: \$656.00

#### VM-15

Fifteen Inch  
Dimensions 16-7/8" H x 15-1 2" W x 17 7/8" D  
Weight 34 Lbs 6 Ozs  
Price: \$1039.00

#### RM-15

Fifteen Inch  
Dimensions 16-7/8" H x 15-1 2" W x 17 7/8" D  
Weight 34 Lbs 6 Ozs  
Price: \$1057.00

#### VM-17

Seventeen Inch  
Dimensions 22-1/4" H x 17-7/8" W x 18 3/8" D  
Weight 57 Lbs  
Price: \$985.00

#### RM-17

Seventeen Inch  
Dimensions 22-1/4" H x 17-7/8" W x 18-3/8" D  
Weight 59 Lbs  
Price: \$1035.00

#### RM-17RC

Seventeen Inch Remote Control  
Dimensions 17-3 4" H x 23-1/4" W x 18-1/2" D  
Weight 61 Lbs  
Price: \$1170.00

#### VM-19

Nineteen Inch  
Dimensions 19" H x 26-3/4" W x 18-5/8" D  
Weight 57 Lbs 8 Ozs  
Price: \$999.00

#### RM-19

Nineteen Inch  
Dimensions 19" H x 26-3/4" W x 18-5/8" D  
Weight 59 Lbs 8 Ozs  
Price: \$1085.00

#### RM-19B

Nineteen Inch  
Dimensions 17-1/8" H x 23-1/4" W x 18-1/3" D  
Weight 55 Lbs 8 Ozs  
Price: \$799.00

#### VM-21

Twenty-One Inch  
Dimensions 28 3/4" W x 20 1/4" H x 17 1/4" D  
Weight: 82 lbs  
Price: \$1425.00

#### RM-21RC

Twenty-One Inch with Remote Control  
Dimensions 28 3/4" W x 20 1/4" H x 17 1/4" D  
Weight 82 lbs  
Price: \$1480.00

#### VM-26

Twenty-Six Inch  
Dimensions 30 1/4" H x 36 1/2" W x 23" D  
Weight 178 Lbs  
Price: \$1780.00

#### RM-26

Twenty-Six Inch  
Dimensions 30 1/4" H x 36 1/2" W x 23" D  
Weight 180 Lbs  
Price: \$1830.00

#### RM-26RC

Twenty-Six Inch  
Remote Control  
Weight 182 Lbs  
Price: \$1995.00

Call or Write for Information on Options

The complete Videotek line of professional Trinitron Plus® color monitors was designed for convenient means of set-up and maintenance, most controls are located on the front panel, thus, permitting the equipment to be easily adjusted and operated. The entire series is constructed of rugged cast aluminum and steel to assure the durability needed in all areas of video productions. To make the professional line complete, Videotek offers the eight inch color monitor, which can be operated on AC or (12v - 24v) DC.

### PROFESSIONAL RACKMOUNT COLOR MONITORS

#### VM-12PR

Twelve Inch  
Dimensions 10-1/2" H x 19" W x 18" D  
Weight 45 lbs  
Price: \$1175.00

#### FEATURES INCLUDE

Raster size regulation, automatic degauss, external sync, keyed back porch clamping, talley light, R-G-B gun switches, A-B inputs, and rackmount accessories

#### OPTIONS AVAILABLE

Pulse cross and underscan

#### VM-12PRO

Twelve Inch  
Dimensions 10-1/2" H x 19" W x 18" D  
Weight 45 lbs  
Price: \$1460.00

#### FEATURES INCLUDE

Raster size regulation, automatic degauss, keyed back porch clamping, A-B inputs, set-up switch, R-G-B gun switches, R-G-B drive and background controls, talley light, external sync, pulse cross, underscan and rackmount accessories

#### STUDIO 12

Twelve Inch  
Dimensions 10-1/2" H x 19" W x 18" D  
Weight 55 Lbs  
Price: \$2360.00

#### FEATURES INCLUDE

High voltage regulation, A-B inputs, A-B split screen, A-B wipe, A-B mix, selectable sync striping in A-B split mode, vector outputs, selectable horizontal time constant, pulse cross, normal/underscan function, switchable internal/external sync, automatic chroma control defeat, talley light, DC restoration, rackmount accessories

#### VM-15PRO

Fifteen Inch  
Dimensions 24-1/2" H x 19" W x 18-3/8" D  
Weight 53 Lbs  
Price: \$1730.00

#### FEATURES INCLUDE

Raster size regulation, automatic degauss, keyed back porch clamping, A-B inputs, set-up switch, R-G-B gun switches, R-G-B drive and background controls, talley light, external sync, pulse cross, underscan and rackmount accessories

#### VM-17PR

Seventeen Inch  
Dimensions 17-1/2" H x 19" W x 21-1/2" D  
Weight 75 Lbs  
Price: \$1730.00

#### FEATURES INCLUDE

Keyed back porch clamping, A-B inputs, external sync, talley light, R-G-B drive and background controls, aperture control and rackmount accessories

#### OPTIONS AVAILABLE

Pulse cross and underscan

#### VM-26P

Professional color monitor  
Twenty-six Inch  
Dimensions 25" H x 26" W x 23-3/4" D  
Weight 175 Lbs  
Price: \$2795.00

#### FEATURES INCLUDE

A-B inputs, internal-external sync, R-G-B gun switches, R-G-B drive and background controls, raster size regulation, keyed back porch clamping, DC restoration, dynamic focusing, velocity beam modulation for improved resolution, internal preset adjustments for chroma, hue, brightness and contrast

#### OPTIONS AVAILABLE

Pulse cross underscan

252

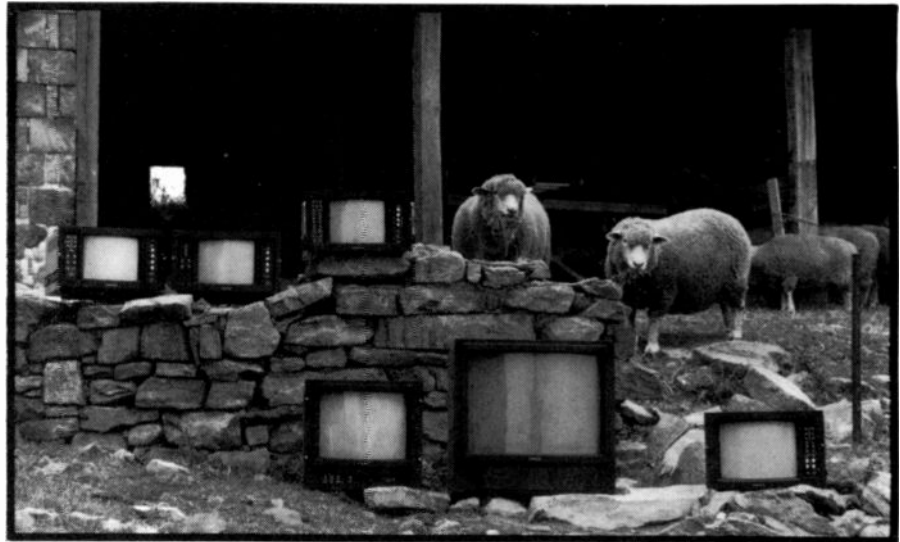

### PROFESSIONAL AC/DC COLOR MONITORS

#### VM-5PR AC/DC

Single five inch color monitor  
Weight 17 Lbs  
Price: \$1240.00

*STANDARD FEATURES ON THE ENTIRE FIVE-INCH SERIES INCLUDE* A-B inputs, internal-external sync, keyed back porch clamping, talley light, R-G-B gun switches, R-G-B drive and background controls, AC/DC

#### OPTIONS AVAILABLE

Pulse cross and underscan

#### VM-8PR AC/DC

Single eight inch color monitor  
Weight 30 Lbs  
Price: \$1130.00

#### VM-8PRA AC/DC

Single eight inch color monitor with Speaker/Amplifier  
Weight 32 Lbs  
Price: \$1233.00

#### VM-8PRW AC/DC

Single eight inch color monitor with space for Videotek s TSM 5 Waveform Monitor  
Weight 32 Lbs  
Price: \$1198.00

#### VM-8PRD AC/DC

Two eight inch color monitors  
Weight 57 Lbs  
Price: \$2160.00

Dimensions on all eight-inch units 8-3/4" H x 19" W x 15" D

#### STANDARD FEATURES ON THE ENTIRE SERIES INCLUDE

Raster size regulation, push button degauss, keyed back porch clamping, A-B inputs, talley light, external sync, R-G-B gun switches, R-G-B drive and background controls and rackmount accessories

#### OPTIONS AVAILABLE

Pulse cross and underscan

### PROFESSIONAL PORTABLE AC/DC COLOR MONITORS

#### VM-5PT

Five inch  
Dimensions 5-1/4" H x 8-1/2" W x 8-1/2" D  
Weight 15 Lbs  
Price: \$1265.00

#### VM-8PT AC/DC

Eight inch  
Dimensions 8-17/32" D x 8-17/32" W x 16" D  
Weight 25 Lbs  
Price: \$1173.00

#### Options Available.

5", 8", 17", 26" Series Pulse Cross  
5", 8", 12", 17", 26" Underscan  
ACC Defeat (12 only)

\$145.00  
60.00  
150.00

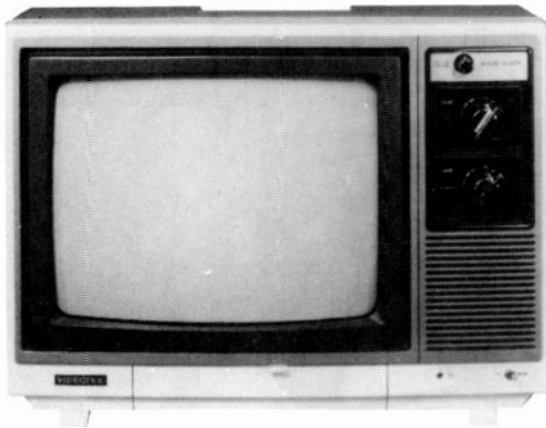

### Videotek RM-13 Thirteen Inch Color Receiver/Monitor

The new Videotek RM-13 is ideal for home computer, classroom, government, industrial and medical use. Priced to be affordable in any budget.

**FEATURES:**  
TV-Monitor Selection  
DC Restoration  
8 Pin VTR Connector  
E to E for Video Taping  
100% Solid State  
Complete AC Chassis Isolation  
Slot Mask In-Line Tube.

**RM-13**  
Thirteen Inch  
Dimensions 13 8" (35 05 cm) H x  
18 7" (47 5 cm) W x 15 0" (38 1 cm) D  
Weight 35 Lbs

**Price: \$656.00**



### Videotek RM-19B Nineteen Inch Color Receiver/Monitor

The Videotek RM-19B is ideal for classroom, government, industrial and medical use. And priced to be affordable in any budget.

**FEATURES:**  
TV-Line-VTR Selector  
DC Restoration  
8 Pin VTR Connector  
E to E for Video Taping  
100% Solid State  
Complete AC Chassis Isolation  
Slot Mask In-Line Tube

**RM-19B**  
Nineteen Inch  
Dimensions 17-1/8" H x  
23-1/4" W x 18-1/3" D  
Weight 55 Lbs . 8 Ozs

**Price: \$799.00**

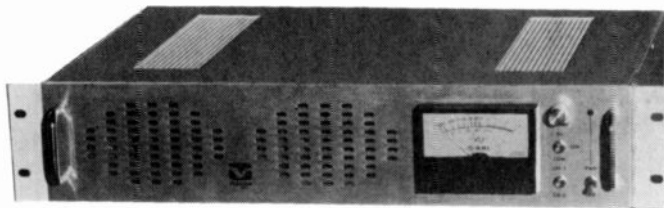

### Videotek APM-2R Audio Program Monitor

The Videotek APM-2R Audio Program Monitor is ideal for remote vans, editing suites, VTR monitor bridges, or for systems monitoring of audio signals.

**FEATURES:**  
2 Inputs - Balanced/Unbalanced  
Wide Bandwidth for  
Accurate Monitoring  
Requires only 3 1/2 Inches  
of Vertical Rack Space

**APM-2R**  
Dimensions 3-1/2" (8 89 cm) H x  
10" (48 26 cm) W x 13" (33 02 cm) D  
Weight 14 Lbs

**Price: \$375.00**

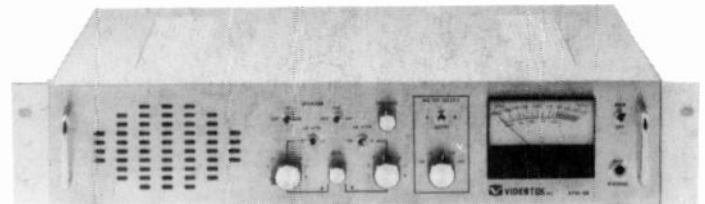

### Videotek APM-8R Audio Program Monitor

The new Videotek APM-8R Audio Program Monitor is designed for professional monitoring of audio signals in remote vans, editing suites, VTR monitoring bridges, or for systems monitoring of audio signals

**FEATURES:**  
8 Inputs - Balanced/Unbalanced  
A/B Channel Mix Capability  
10 Watt Amplifier  
External Speaker Output  
Headphone Jack on Front Panel  
115/230 VAC - 50/60 Hz or  
+ 12 VDC Operable

**APM-8R**  
Dimensions 3-1/2" (8 89 cm) H x  
19" (48 26 cm) W x 13" (33 02 cm) D  
Weight 18 Lbs

**Price: \$799.00**

# The Winsted Corporation

**"MATCHMAKER SYSTEMS"**  
The perfect match for your  
video equipment

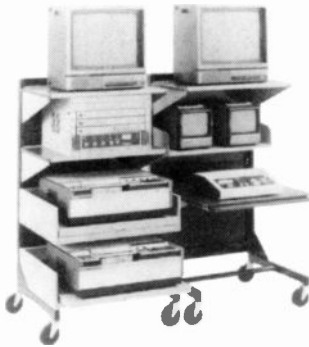

(A) 901A  
\$1168.00



(B) 900C  
\$1335.00

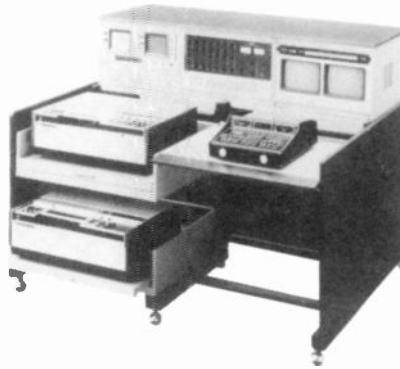

(C) 900LC  
\$1662.00



(D) 3101-T  
\$1972.00

## THE "EDITING" GROUP

**A. MODEL 901A EDITING CONSOLE.** Shelves adjust in 1" increments for perfect working height. All steel VTR shelves pullout with 12" safety stop. Editor shelf has 12" pull out work surface for scripts and schedules. Removable back panels conceal a 2" X 28" cable raceway. Overall dimensions 56" H X 28" D X 60" W.

**B. MODEL 900C CONSOLE.** Rugged steel construction. All shelves adjust in 1" increments for comfortable working height. Model shown is bolted together as in line console. Editor shelf pulls out 12" for better viewing of screens and dials. Console rolls on 5" industrial casters (2 locking). Overall dimensions 72" H X 28" D X 60" W.

**C. MODEL 900LC LOW PROFILE EDITING CONSOLE.** Same rugged construction as all other Winsted Consoles. Console shown with three 14" rack cabinets. Other rack cabinets and configurations are available. Includes decorative walnut woodgrain side panels and top 2 pullout VTR shelves and one editor shelf. Overall dimensions 46" H X 45" D X 62" W.

**D. MODEL 3101-T VTR CONSOLE.** Holds any 1" VTR. Overhead bridge adjusts up or down has 10" rack space for monitor and rack cabinets for vector scope and wave form monitor. Base cabinet has turntable that rotates 360° for easier servicing and viewing. Ecessed rmaster on off switch. 19" rack height for TBC and pull out drawer for manuals and tools. Overall dimensions are 78" H X 28" D X 32" W.

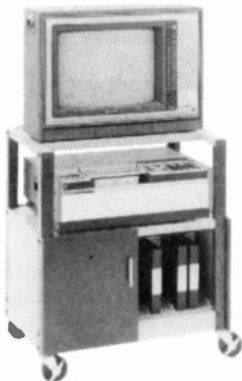

(E) A/V-34B  
\$219.00

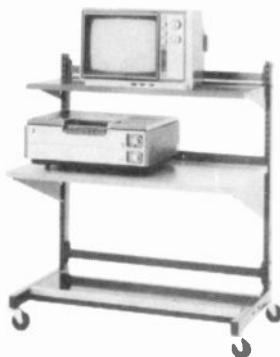

(F) 900MVC  
\$259.00

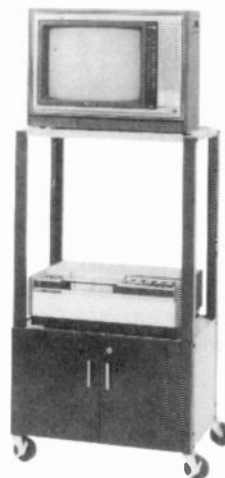

(G) A/V-54B  
\$239.00

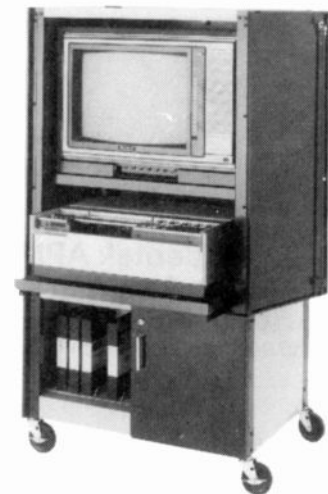

(H) A/V-60EC  
\$489.00

## THE "VIDEOCENTER" GROUP

**E. MODEL A/V-34B LOW PROFILE MOBILE VIDEO CENTER.** Designed for smaller groups or individuals. Top shelf is set back for easy access to VTR. Lockable base cabinet holds tapes or valuable video equipment. Center rolls easily on 4" industrial casters (2 locking). Overall dimensions are 42" H X 22" D X 36" W.

**F. MODEL 900MVC ECONOMICAL MINI VIDEO CONSOLE.** Wooden recorder shelf and steel monitor shelf. Each adjusts in 1" increments for greater working comfort. Rolls effortlessly on 3" industrial casters (2 locking). Includes 3 outlet electrical assembly with 3 wire 6 foot cord. Overall dimensions are 42" H X 22" D X 36" W.

**G. MODEL A/V-54B STANDARD HEIGHT VIDEO CENTER.** Ideal for conference rooms and large groups. Lockable lower cabinet for video tapes and equipment. All steel construction with beige and cocoa brown finish. Console moves easily on 4" industrial casters (2 locking). Overall size 54" H X 22" D X 32" W.

**H. MODEL A/V-60EC VIDEO CONSOLE.** Provides complete equipment security. Top section has pull out VTR shelf for easier player operation and adjustable monitor shelf holds most 21" monitors. Ventilated locking rear panel provides full access to rear of video equipment. Bottom cabinet stores tapes and other video accessories. Overall dimensions are 60" H X 20" D X 30" W.



# The Winsted Corporation

**"MATCHMAKER SYSTEMS"**  
The perfect match for your video equipment

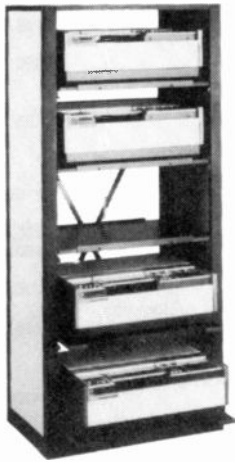

(I) 450A  
\$676.00



(J) 464A  
\$748.00



(K) V/C-72WO  
\$747.00

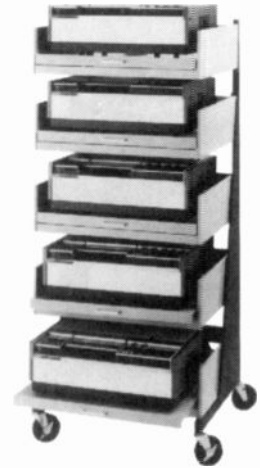

(L) 990A  
\$1073.00

## THE "DUBBING" GROUP

**I. MODEL 450A STATIONARY DUPLICATING CENTER.** All shelves are on ball bearing rollers for easy pull out of machines vertically adjustable in 1" increments. Steel construction with beige and cocoa brown finish with walnut woodgrain shelves. Units can be bolted together for economical duplication system. Overall dimensions are 72"H X 20"D X 30"W.

**J. MODEL 464A SPACE SAVING DUPLICATING CONSOLES.** Four pullout VTR shelves. Rack cabinet gives 14" of rack space for switching and monitor equipment. All shelves vertically adjust in 1" increments. Overall dimensions are 72"H X 20"D X 30"W.

**K. MODEL V/C-72WO DUPLICATION CENTER.** For 1" formats. All 6 shelves pull out for easier operation and are adjustable in 1" increments. Console rolls on 5" industrial casters (2 locking). Overall dimensions are 72"H X 20"D X 22"W.

**L. MODEL 990A MOBILE 1/2" DUPLICATION CONSOLE.** Rugged all steel construction. VTR drawers pull out on ball bearing rollers. All shelves vertically adjust in 1" increments. Console moves on heavy duty 4" industrial casters (2 locking). Overall dimensions 72"H X 26"D X 30"W.

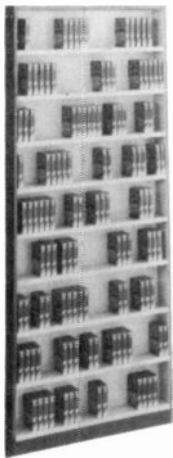

(M) TC-5BB  
\$397.00



(N) TC-12B  
\$430.00

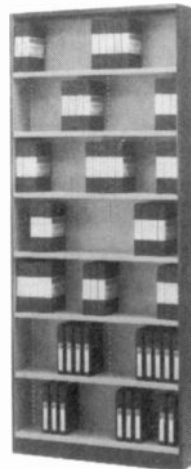

(O) TC-8B  
\$412.00

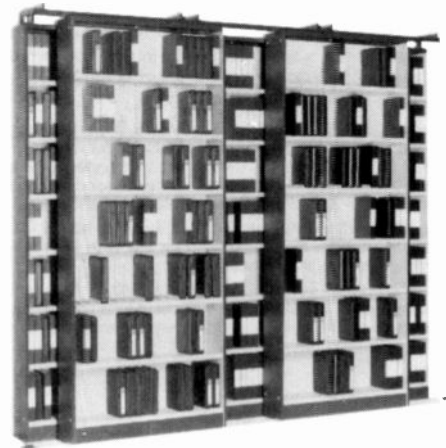

(P) High Density Storage System

## THE "STORAGE" GROUP

**M. MODEL TC-5BB VIDEOCASSETTE STORAGE.** For 1/2" videocassettes. All shelves are adjustable in 1" increments. Hold 270 Beta tapes. All steel construction with beige and cocoa brown finish. Overall dimensions 88"H X 5"D X 36"W.

**N. MODEL TC-12B VIDEO TAPE STORAGE.** System holds 102 1" video tapes. 12" deep cabinet also holds 10 1/2" and 7" quad tapes. By adding more cabinets the system can grow into a High Density Storage. Overall dimensions 88"H X 5"D X 36"W.

**O. MODEL TC-8B U-MATIC TAPE STORAGE SYSTEM.** For 3/4" U-Matic tapes. Bolt together construction with adjustable shelves. Holds 161 video cassettes. Inside dimensions 83"H X 8"D X 34 1/2"W. Overall dimensions 88"H X 8"D X 36"W.

**P. MODEL TC-8B TYPE HIGH DENSITY STORAGE SYSTEM.** This is an example of Winsted's High Density Storage System for 1/2" U-Matic tapes. Also available for all other tape formats. Movable cabinets roll easily on steel tracks.



# ZEI-MARK

## MULTIPLEXER

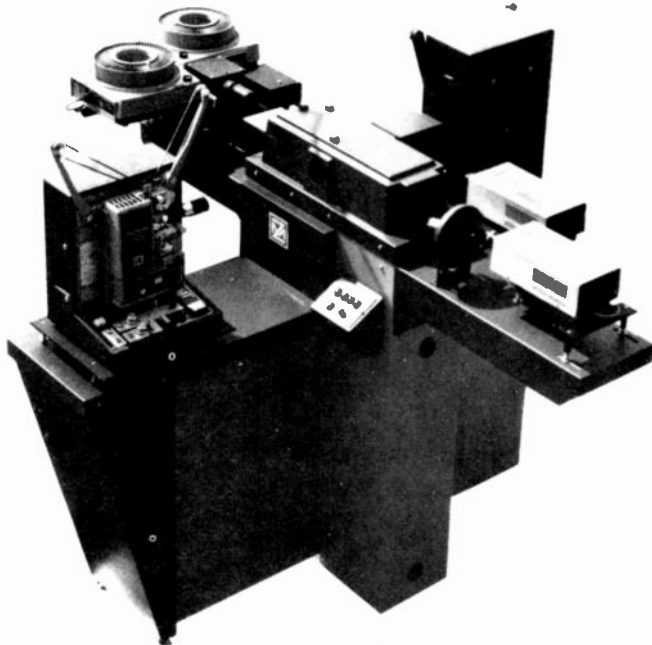

### MODEL 4305 OPTICAL MULTIPLEXER

Model 4305 consists of a pedestal mounted optical transfer assembly designed to the industry standard 48 inch optical centerline. The basic unit includes local control, neutral density filter mounts for each input, three duplex AC outlets (6) for equipment, attached 3-wire AC power cable and complete set-up and operating instructions.

All options are at added cost.

TV camera and center input projector supports as well as projector side mounts include all necessary adjustable mounting hardware for item to be used. Please indicate TV camera and projector types to be used at time of order.

Where remote control is specified, please indicate cable footage required.

Projectors ordered from ZEI-MARK include the necessary projection lens.

Remote control is 24VDC operation.

The Preview option, 2nd TV camera output, is particularly desirable, providing a back-up TV camera in the event of prime output camera failure and to minimize "on-air" errors, e.g., wrong slide, improper start or restart of motion picture film, etc., since Preview enables the operator to verify subsequent inputs while "on-air" from the second TV camera which may be a relatively inexpensive monochrome camera.

Since the 4305 optical multiplexer is in itself a fully functional and operational system, the unit may be directly applied for use with floor mounted TV cameras and pedestal mounted film projectors.

Where floor mounted TV cameras have a built-in field lens designed to suit the internal camera optical system, the 4305 field lens can simply be removed to permit direct projection thru the 4305 optical transfer and onto the TV camera field lens.

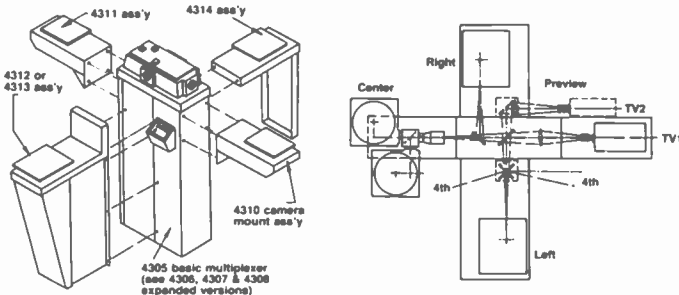

**Notes:**

- For models 4307 and 4308, 4th Input source must be reversible format film, e.g., 2 x 2 slides, 35mm filmstrip, and "live" Tel-Op input.
- For 1" format vidicon TV cameras, use 50mm "C" mount lens. For 3/4" format vidicon TV cameras, use 35mm lens.
- At time of order, please specify TV camera and projector models to be used at each input station.
- For TV cameras, which due to their design require special lenses (other than 35mm or 50mm focal lengths), ZEI-MARK can supply special field lenses to work with such TV camera at added cost (usually nominal).

### SERIES 4300 OPTICAL MULTIPLEXER & ACCESSORIES

MODEL NO.	DESCRIPTION	PRICE
4305	Optical multiplexer, 3 inputs and 1 output. Custom model. Expandable to add Preview and 4th options. Features custom molded top cover, illuminated dome lamps w/matching colored switches at local control console	\$ 1995.00
4306	Custom optical multiplexer, 3 inputs and 2 outputs. Expanded model 4305. 2nd output Preview	2795.00
4307	Custom optical multiplexer, 4 inputs and 1 output. Expanded model 4305. See notes	2995.00
4308	Custom optical multiplexer, 4 inputs and 2 outputs. Expanded model 4305, combination model 4306 & 4307.	3495.00
<b>TV CAMERA &amp; PROJECTOR SUPPORTS</b>		
4310	TV camera support and adjustable mount. Fits all models	\$ 215.00
4310-SP	Same as 4310, but for TV cameras in excess of 30 lbs.	250.00
4311	Center input projector support.	150.00
4312	Custom fully skirted side mount for Left and Right film projectors. Fits all models.	295.00
4313	Custom side mount for Left and Right film projectors, less skirts. Fits all models	250.00
<b>PROJECTOR PEDESTALS</b>		
KP	Pedestal for either TV12M6 or TVM100A with adjustable mount. 48 inch optical centerline.	\$ 300.00
KG	Pedestal for either 930 or 930R with adjustable mount. 48 inch optical centerline	350.00
<b>MULTIPLEXER REMOTE CONTROLS</b>		
RC4305	Model 4305 remote control. Select Left, Center or Right input. Console styled 19 inch rack mount for either flat or vertical mounting. 3 1/2" high. Illuminated to match 4305 dome lamp colors.	250.00
RC4306	Model 4306 remote control. Same as RC4305 except includes Preview select switches	275.00
RC4307	Model 4307 remote control. Same as RC4305 except includes 4th Input mode select switches	275.00
RC4308	Model 4308 remote control. Same as RC4305 except includes both Preview and 4th Input switches	300.00
<b>PROJECTOR RC MOUNTING PANELS</b>		
PRC-3	3 1/2 x 19 inch rack panel for mounting up to three RC modules listed below.	\$ 70.00
PRC-4	3 1/2 x 19 inch rack panel for mounting four projector remote controls listed below. Custom designed to suit system requirements	175.00
<b>PROJECTOR REMOTE CONTROL MODULES</b>		
RC-2	E-2 remote control. Lamp on/off, forward and reverse.	\$ 150.00
RC-2LD	LD-4200 remote control. "Change" and dissolve "rate" only.	100.00
RC-2LDX	LD-4200 remote control. Includes change, rate, individual E-2 forward and reverse and "hold" to repeat or alternate slides.	200.00
RC-8K	TVM100A remote control provides forward, forward w/lamp, reverse w/lamp and stop.	200.00
RC-16K	TV12M6 remote control provides forward, forward w/lamp, reverse w/lamp and stop.	200.00
RC-16S	Singer 930 & 930R remote control. Forward, forward w/lamp & stop.	200.00
RC-16E	Eiki RT-0 remote control. Forward, forward w/lamp, reverse & stop.	200.00
RC-16	Remote control for 16mm projectors not listed above. Up to four control switches (momentary and/or p-p)	200.00
RC-ND1	Remote control for ZM-ND1 automatic light control. Includes AGC and manual control	100.00
ND4	Compact optical assembly and separate control unit. Rim-driven 6 inch diameter Inconel coated glass attenuator same as above. Includes 25ft. cable between optical assembly and control unit.	1795.00
<b>REMOTE CONTROL CABLES</b>		
C1	Multiplexer remote control cable	\$1.00/ft.
C2	Projector remote control cable	\$1.00/ft.
<b>ND FILTERS</b>		
FK-6	Filter kit. Set of six (6) 3 x 3 inch Kodak gelatin ND filters w/values 0.1, 0.2, 0.5, 1.0, 2.0 and 3.0. Up to six may be ordered in any combination. Filter mounts and glass supplied as std. on all 4300 and 2000 series multiplexers	\$ 70.00
<b>MISCELLANEOUS</b>		
A43	Audio-follow control PC board assy. For use with 4300 series multiplexers. Audio switches according to the multiplexer mode. Accepts up to 3 wires from 3 separate sources to a 3 wire output. Operates automatically from mult. control electronics.	\$ 140.00
SLOT-LQK2	Easy on, easy off TV camera mount. Use with all multiplexers. Allows for dual TV camera use and minimizes TV camera set-up.	250.00
SLOT-LOK 1	One camera adaptor and one base	175.00
SLOT-LOK 2	One camera adaptor and two bases	250.00
SLB	Base only	85.00



VC-4-DA

## Wilson VC-4-DA Video Console

In a single, compact cabinet console, the VC-4-DA combines space for a monitor up to 21", a ball-bearing smooth slide out shelf for even the largest video recorder, and a convenient drawer for video cassettes and other materials. Semi-concealed swivel casters.

May be ordered Factory Assembled only.

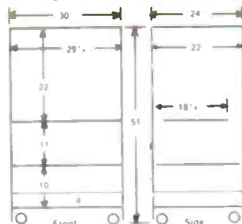

Model No.	Dimensions	Shipping Wt. (Lbs.)	Price
VC-4-DA	51"Hx30"Wx24"D	220	\$665.00

## Wilson VCM 53 Video Console

A sturdy metal and wood video console that holds up to a 21" monitor. Monitor shelf is adjustable. Has a second ball bearing supported glide-out shelf for your video recorder. Also adjustable. Heavy gauge steel cabinet has charcoal brown baked enamel finish. Walnut grained laminated wood doors have full length continuous hinges and three-point locking action. 4" swivel casters; two lock. Overall size: 53"H x 32"W x 31"D. Ships unassembled.

Model VCM 53 Shipping weight 152 lbs. Price \$468.00



VCM 53



VC-5-D

## Wilson VC-5-D "Low-Boy"

A contemporary blend of black enameled square tubular steel and walnut grained wood laminate, the VC-5-D has the structural strength to hold the heaviest of video equipment. The walnut grained top shelf is recessed to permit easy access to the video recorder. Bottom cabinet, also of walnut grained laminated wood, has locking doors to give you secure storage for cassettes, other video materials. Moves effortlessly on fine furniture 2" hooded ball casters. Shipped semi-KD, with the base cabinet fully assembled.

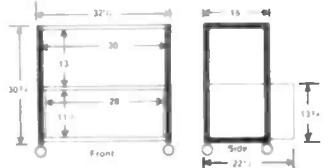

Model No.	Dimensions	Shipping Wt. (Lbs.)	Price
VC-5-D	30 3/4"Hx32 1/2"Wx22 1/2"D	90	\$299.00

## Wilson VCM 32C Video Console

An all-metal "Low Boy" video console complete with locking cabinet and hooded ball casters. Heavy gauge steel cabinet and shelves have charcoal brown baked enamel finish. Tubular steel frame and legs are chrome plated. Top shelf; 30"W x 15"D. Second shelf; 20 1/2"D. Cabinet interior; 30"H. Overall; 32 1/2"H x 32"W x 20 1/2"D. Ships partially assembled. Shipping weight 56 lbs. Model VCM 32C Price \$238.00



VCM 32C



VCM 32

## VCM32 Console

Same construction, finish, and size as the VCM 32C, but does not have locking cabinet. Ships UPS unassembled. Shipping weight 30 lbs.

Model VCM 32 Price \$152.00

# Video Centers, Cabinets, Tables, Mounts



VTR-40



W48S

## Compact Video Center

Wherever space and budget may be limited, the Wilson VTR40 is ideal. Floor space requirements are a mere 18" x 24".

The base cabinet provides "lock and key" security for video and other materials, while the adjustable height top shelf provides a sturdy platform for your video monitor. Space between the top of the base cabinet and the top shelf may be adjusted to 6-5/8", 10-5/8", or 17-3/4".

Side, and front and back, openings are 15" and 20 3/4" which makes removal of many VCR's virtually impossible without first removing the top shelf assembly.

The VTR40 rolls effortlessly on 2" hooded ball swivel casters. Colors of the baked enamel finish are brown and almond. "E" Model furnished with electrical assembly.



VTR29MC



W48SC

Model	Ht. (In.)	Shelf Size (In.)	Approx. Ship.Wt. (Lbs.)	Price
VTR40	40"	18x24	54	\$178.00
VTR40E	40"	18x24	56	200.00

\*With shelf at highest position.

## Video Tables and Cabinets

Wilson Tables give you a choice of flat or 5° slanted top shelves, as noted in the ordering information below. All except SPEC 48 feature "Uni-Strong" shelves with raised rims on all four sides. Cabinetized Tables provide "lock and key" storage. All units feature easy-rolling 4" swivel casters; two may be locked. Non-slip rubber mats are provided for the top shelves.

Model No.	Description	Ht. (In.)	Top to Middle Shelf (In.)*	Middle to Bottom Shelf (In.)*	Shelf Size (In.)	Ship. Wt. (Lbs.)	Price
W54S	Top shelf slants 5°	54	25	17 1/2	24x28	59	\$154.00
W54TV	Top shelf flat	54	26 1/2	17 1/2	24x28	62	150.00
W48S	Top shelf slants 5°	48	19	17 1/2	24x28	56	147.00
W48TV	Top shelf flat	48	20 1/2	17 1/2	24x28	57	143.00
SPEC48S	For extra wide TV, top shelf slants 5°	48	20 1/2	17 1/2	25x34	69	187.00
W42TV	Top shelf flat. For TV and general use.	42	12 1/2	17 1/2	24x28	55	140.00

### TV WALL MOUNT



900



Easy to mount on any wall or remove for service.

"Theft-proof" locking device. Full swivel and tilt. Universal mounting slots accommodate all commercial size TV. Heavy gauge all steel construction. Dark Brown finish.

Model	Load Limit	Shp. Wt.	Price
900	200 lbs.	15 lbs.	\$116.00



### TV CEILING MOUNT



200



Fits any make or size. Rotate full 60° and tilt up or down 15°. All parts of heavy gauge steel and finished in dark brown. TV set bolted securely to mount. Load limit 200 lbs.

Model	Description	Shp. Wt.	Price
200	Cradles from underneath	25 lbs.	\$116.00

ACCESSORIES. AWB; converts Model 200 for wall suspension; \$36.00. TVCP Extra Ceiling Plate for mounting Model 200 with a drop ceiling; \$12.00

### TV CABINETIZED TABLES

W54SC	Top shelf slants 5°	54	25	17 1/2	24x28	78	\$230.00
W54C	Top shelf flat	54	26 1/2	17 1/2	24x28	78	226.00
W48SC	Top shelf slants 5°	48	19	17 1/2	24x28	75	224.00
W48C	Top shelf flat	48	20 1/2	17 1/2	24x28	76	220.00
W42TVC	Top shelf flat	42	12 1/2	17 1/2	24x28	74	217.00

### VIDEO TABLES AND CABINETS

VTR29	Open table for video equip.	29	-	20 1/2	18x40	46	\$119.00
VTR29MC	Fully enclosed 2 locking doors	29	-	20 1/2	18x40	65	221.00

Specify "E" for electrical assembly; add \$22.00

\*Dimensions indicate clearance between shelves.

## WILSON UNCONDITIONAL WARRANTY

Wilson products have been engineered and manufactured to exacting quality standards. The H. Wilson Company Unconditionally Warrants that should any item be defective in either parts or workmanship for a period of one year from purchase date, it will be replaced or repaired (mfg. discretion) without charge. This warranty does not cover damage in transit.

### Accessories for items this page

WEA Electric Assembly - 20' power cord with double receptacle; U.L. listed; \$27.00. CSA approved \$30.00. 5" Casters; \$11.00. AWS Web Strap to hold receiver securely to top shelf 11'; \$18.00. W15058 Tape Rack holds 24 video tapes; \$32.00

**HWC** H. WILSON COMPANY

EBSCO INDUSTRIES, INC.

South Holland, Illinois 60473

Printed in U.S.A.

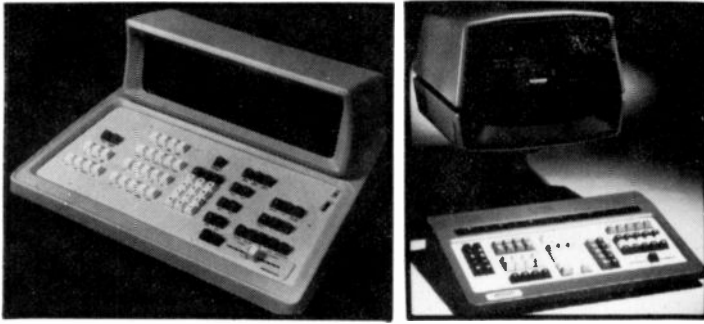

### TEMPO 76 EDITOR

- Frame-Accurate Editing
- Program Duration Display
- Event Duration Display
- VaraScan™ — Slow Motion, Reverse and Freeze-Frame Viewing
- Alphanumeric Self-Scan Panel Display by Burroughs Features Large, Easy-To-Read Character Display Panel with 80% Contrast Ratio
- Keypad Entry of Edit Parameter
- Edit Shift and Edit Trim
- Manual Preview
- Automatic Preview
- Automatic Edit
- Two Audio-Channel Edit Capability
- Audio, Audio/Video and Video Edit Selection
- Switcher Control
- Auto-Assembly
- Edit Decision Storage
- Text Edit Option
- A/B or B/A Rolls
- Special Memory to Speed-Up Succeeding Edits Edit Abort Logic
- Servo Sync of Two or Three VTR's
- Motion Control of One, Two or Three VTR's
- Automatic Search of One, Two or Three VTR's
- Extended Memory to 300 Events
- System Debug Option

The new Datatron TEMPO 76 Series is a high-performance, microprocessor-centered, expandable control system that takes advantage of integrated circuitry to provide state-of-art ease and flexibility in either Control Track and/or SMPTE Time Code editing modes.

The control center of the series is the TEMPO 76 Editor, featuring TIME SYNC\* and VARASCAN\*. The Editor can function equally well using standard SMPTE Edit Code or the standard Control Track pulses.

When using the standard SMPTE Edit Code, the code is recorded on one audio channel (usually the cue track) of the program material source tape and the electronically-edited master tape (EE master).

Since each recorded event coincides with a specific time value to the frame, TIME CODE makes it possible to locate any scene by running the tape to a designated time.

Similarly, when editing in a Control Track mode, pulses are recorded on the magnetic tape coincident with each field. By counting these pulses, TIME SYNC makes it possible to identify the actual frame of video information required to generate the (EE) master. Of course, control-pulse editing is not as consistent nor as accurate as SMPTE Time Code Editing.

With the TEMPO 76 Editor as a base, one can begin building his ultimate editing capabilities gradually with a two-VTR Time Sync or SMPTE System.

The TEMPO 76 Editor provides for automatic synchronization of video tape recorders (VTR's) and the precise transfer of information from a playback source to a "record" VTR.

### VANGUARD EDITOR

The Vanguard is a high-performance microprocessor based editing system uniquely suited for today's highly creative, cost conscious editing environment. It allows you to perform fast, accurate edits involving up to five VTR's and a switcher—on-line or off-line, SMPTE code or control track. It offers features and conveniences normally found only in expensive, top-of-the-line editing systems, including: an interactive CRT operator display and color coded dedicated function keyboard; adjustable operator reaction time compensation; selectable preroll and postroll times; dual Varascan™ shuttle controls; auto assembly; edit list management; and a large selection of VTR, ATR and film chain interfaces, just to name a few.

#### • TOTALLY FLEXIBLE VTR INTERFACING

Field-proven interfaces are available to allow the Vanguard to operate with a wide variety of VTR's, ATR's and film chains.

#### • OPERATES WITH A VARIETY OF SWITCHERS

Vanguard interfaces to a number of manufacturers' computer compatible switchers, including Datatron's own 2100E model.

#### • SMPTE CODE OR CONTROL TRACK OPERATION

Insert or assembly editing can be performed on the Vanguard using either SMPTE time code or control track pulses for tape position referencing (a SMPTE jam-sync generator is required to perform assembly edits in SMPTE mode).

#### • DUAL VARASCAN™ SHUTTLE CONTROLS

VTR's capable of variable speed play and shuttle modes can be controlled by Datatron's Varascan variable speed slider search control.

#### • MARK EDIT POINTS ON-THE-FLY OR KEYBOARD ENTER THEM

Edit-in and edit-out times can be marked on-the-fly from the time code being read from a moving tape, or they can be entered manually from the keyboard.

#### • FIVE TIER SCRATCHPAD MEMORY WITH TIME CODE CALCULATOR

The CRT scratchpad display can accommodate up to five memorized time code values entered from the keyboard.

#### • FULLY AUTOMATIC CUEING, PREVIEWING AND EDITING

The Vanguard offers fully automatic cueing, previewing and editing sequences involving up to three VTR's, plus a single VTR preview sequence.

#### • ON-THE-FLY (SYNC'D ROLL) EDITS AND PREVIEWS WITH UP TO FOUR SOURCES

Vanguard can perform edits and previews on-the-fly with up to four source VTR's rolling.

#### • UP TO 999 EVENTS OF EDIT LIST MEMORY WITH POWERFUL LIST MANAGEMENT

Vanguard can store up to 999 lines of edit events in its semiconductor memory; 320 events of memory come standard.

#### • AUTO ASSEMBLY FROM UP TO FOUR PLAY SOURCES

The entire edit decision list, or a designated block of it, can be automatically previewed or edited sequentially, pausing only when new reels must be mounted, or when a manual switcher setting is required.

#### • AN OPERATOR KEYBOARD AND DISPLAY THAT GUARDS AGAINST ERRORS

All editing functions of the Vanguard system are controlled by the operator from a desktop keyboard and CRT display.

#### • EDIT LIST INPUT/OUTPUT IN INDUSTRY-STANDARD FORMATS

The Vanguard can be equipped with several types of edit list input/output devices.

### Equipment & Service for:

- Studios
- EFP
- ENG
- Security
- Surveillance
- Interactive training
- Cable
- Low power T.V.
- Tele conferencing
- Data Display

### Video Images Provides:

- Engineering
- Design
- Equipment Sales
- Equipment Rentals
- Video Tape
- Service
- Consulting
- Installation
- Customer Service
- Product Training

# Video Images

Electronic Video is the key to communications in the '80's! And not just broadcast video, nor consumer video for the home. We're talking about CORPORATE video, INSTRUCTIONAL video, EDUCATIONAL video, SECURITY video. And, VIDEO isn't just pictures, it's PROFITABILITY for your organization.

Video has the ability and diversity to significantly improve the fundamental operations of your business. From employee relations and motivation to new product introductions; from sales training to security and surveillance. Video offers what no other me-

dium can - both sight and sound in a variety of appealing modes.

VIDEO IMAGES is the source for all your video needs, with quality components at competitive prices. Thousands of advanced technology products and supplies from 100 top name brand suppliers and manufacturers. This allows you to compare the largest assortment of video equipment available in one location.

However, VIDEO IMAGES is much, much more than products and supplies. Our commitment to excellence in sales, selection and service insures your complete satisfaction for whatever function video serves you. "Service after the sale" will always be our first concern.

12200 West Adler  
Milwaukee, WI 53214  
(414) 475-0111

811 Mayfair Avenue  
Madison, WI 53714  
(608) 241-5281

9909 Valley View Road  
Minneapolis, MN 55344  
(612) 941-9267

PO Box 3855  
Green Bay, WI 54303  
(414) 822-5975

And Grouping . . .