

GRUNDIG

T

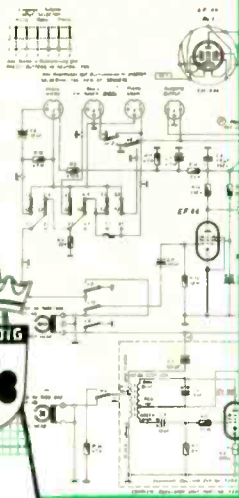

Repair Manual

TK 1
TK 1 E

AND
POWER
PACK

ALL-TRANSISTOR TAPE RECORDER



GRUNDIG WERKE FÜRTH/BAY. · W.-GERMANY · P. O. BOX 205

DESCRIPTION OF FUNCTIONS AND MECHANICAL TESTS

EXPLODED VIEW OF CLUTCHES

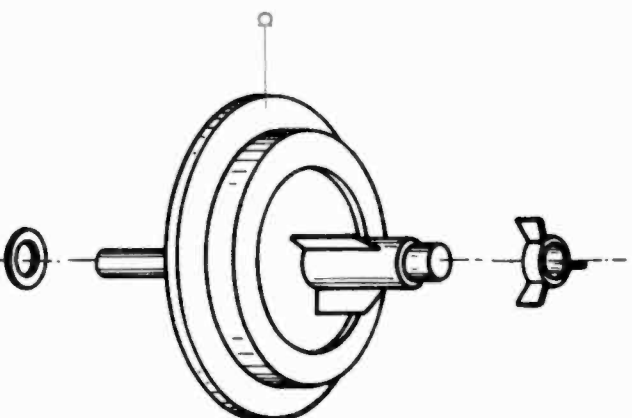
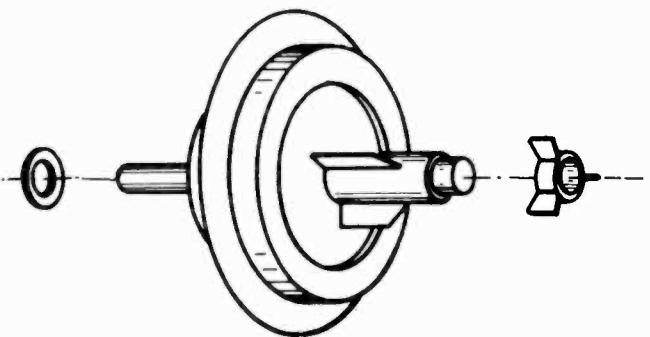

By turning part **b** the friction torque between the upper clutch half **a** and the lower clutch half **c** can be adjusted. When turning part **b** clockwise the friction is reduced, turning anticlockwise the friction is increased. The adjusted position is located by means of the screws **d**.

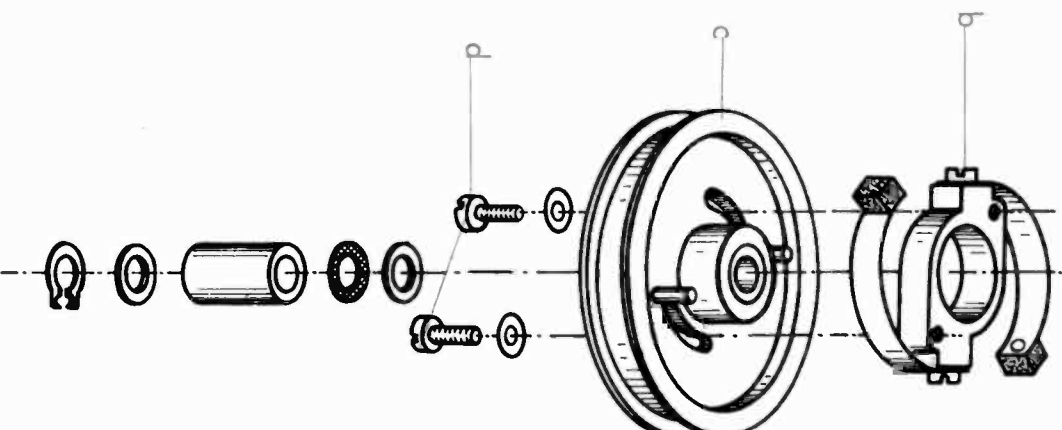

Measuring Values and Adjustments

In General

Clean rubber surfaces contribute remarkable to the operating reliability of the tape drive mechanism. For cleaning use dilution 10 007.

When reassembling the chassis pay attention please, the contacts K on the printed circuit panel may work unobjectionably.

After having finished repairs safety-varnish again the parts which have been secured by varnish before.

Sometimes, it happens, that „Glue for every purpose“ ist used to repair plastic parts, but Grundig Tape Recorders do not like it very much. For polystyrol and other plastics, Methylchloride, Benzol and Aceton are most suitable for gluing. But attention please, apply with a fine brush and in very small quantities. Surfaces, on which one of these chemicals are spilled, look horrifying. For gluing plastic parts on metal use adhesion glue B 206 (produced by Messrs. Henkel).

Measurement of the mechanical unit should be done with Spring Balances and Spring Blade Adjusters.

Some addresses from where they can be ordered:

Spring Blade Adjusters:

Messrs. Georg Karstens G. m. b. H.
(14a) Stuttgart - S
W. - Germany

Spring Balances (all-metal)

Messrs. Robert Krups
(22a) Solingen - Wald
W. - Germany

Spring Balances of cardboard
(for small values)

Lehrmittelbau Prof. Dr. Maey
(22c) Bonn
W. - Germany

Lubrication

Before oiling the self-lubricating bearings, note the following: Bearings of sintered iron permit long periods of operating without service, (approx. 3,000 operating hours, several years at normal conditions).

Use for:	self-lubricating bearings	:	Tereso 47
	sinter washers	:	Depofett F 2
	friction marks	:	Sovarex
	remaining bearings	:	Vollol-Öl 0

Description of Functions

The tiltable motor assy. pos. 1 is mounted in its bracket pos. 2 which is equipped with the components for speed stabilizing. The motor bracket is to be adjusted by means of the screws pos. 3 until the shaft of the motor pulley pos. 4 is directed to the shaft of the flywheel pos. 5. This adjustment is necessary to obtain a correct friction between motor pulley and rubber rim of the flywheel position 6 at a loss as small as possible. On replacement of the motor assy. take care that the rubber rim of flywheel is engaged at the first third part of the motor pulley surface (seen from the motor assy.). The shaft of the flywheel is supported in oilite bearings (upper and lower). The lower bearing pos. 7 is adjustable mounted on slider pos. 8 which can be adjusted itself a small amount.

The free play of the shaft of the flywheel may not exceed 0.2 mm; adjustable by means of screws pos. 9. During operation the motor pulley may press against the rubber rim of the flywheel with 120-150 gr. Adjustable by means of screw c/w tension spring pos. 10 (covered).

It may be necessary to adjust the locking positions of the selector switch regarding to the symbols of the operating indication foil; to do it turn the click-stop arrangement radially by means of the bearing bolts of both stop levers pos. 12 (accessible underneath the chassis). Adjust in the same way if the selector switch does not rest accentuated any more.

Left-Hand Clutch and Brake

Left-hand spindle pos. 13 and brake pos. 14 are mounted with an axial free play of 0.2 mm.

The brake torque of the left-hand clutch spindle in the position **stop** and **start** reads 45... 55 cmgr., measured with tape on the tape reel having a diameter of 60 mm ($r = 3$ cm). The brake torque is adjustable by bending horizontally the hang-in tongue for tension spring pos. 15.

In **rewind** position idlerwheel pos. 16 may undercut 1... 2 mm the friction surface of the lifted left-hand clutch (remove grip ring pos. 17), see fig. 3. For adjustment set the slidable bearing of the rewind lever pos. 18.

The friction torque between idler wheel and left-hand clutch reads ≥ 100 cmgr. with an engaged Spring Blade Adjuster (engaged in a tape loop).

The screw pos. 19 effects the lifting action of the brake lever. When adjusted correctly should be a distance of 0.3 – 0.5 mm between the head of the screw and the tongue of the brake lever in **stop** position.

The brake lever should be slidable in direction of the slot (i. e. to suit the diameter of the brake drum). Pay attention please, that the connection lead of the magic eye does not lock the moving action of the brake lever.

Right-Hand Clutch and Brake

The right-hand spindle pos. 20 is mounted with an axial free play of 0.2 mm. The friction torque of the right-hand spindle reads in position **stop** 90–140 cmgr. and in position **rewind** 18 cmgr. (tape pulled clockwise).

As soon as the flat drive belt pos. 21 is stretched the lower clutch half gets a torque of ≥ 65 cmgr. In positions **playback** or **recording** with the running motor, it is measured by means of a Spring Blade Adjuster which is hanged-in into a tape loop and which should follow the tape pull action. (Lock lower and top clutch halves by means of a pin which should be inserted inao the 1 mm ϕ hole of the right-hand spindle, it can also be done by means of an adhesive tape by putting it onto the outer edges of both clutch halves).

The flat drive belt should be fitted with its fabric side inside. The adjustable belt stretcher position 22 should stretch the belt by means of its roller with a pressure of 75 gr. in direction to the recording head. It is measured with running motor. After adjustment tighten screw pos. 28 on the stretcher lever. The friction torque of the upper clutch half in positions **recording** or **playback** reads 30–45 cmgr. with running motor, measured by means of a Spring Blade Adjuster which follows the tape pull action. Adjust as described on page 2. The lever pos. 25 can be adjusted by setting the lock nuts on tie rod pos. 24. Correct adjustment is obtained in pos. stop if the motor pulley is free of the rubber rim of the flywheel and a brake action of the fly-wheel takes place simultaneously.

In positions **recording**, **playback** and **rewind** the lever pos. 25 might lift the brake pos. 26 0.5 mm max. It is adjusted by bending the free end of the brake lever.

Tape Drive (figures 1 and 2)

The center of tape should have a distance of 22.25 mm from the top edge of the chassis with the tape running in the center of the tape reels, thereby the distance between top edge of chassis and lower edge of tape guide post pos. 27 may be approx. 19.12 mm.

The recording head pos. 28 is mounted in a distance of 2.5 + 0.1 mm before the connection line between the two outer tape guide posts. After adjustment tighten grub screw pos. 29 which is tightened by a counter nut. The gap of the recording head may overlap the top edge of the tape 0-0.1 mm. Small corrections can be done by means of the tape guide posts.

The gap of the erase head pos. 30 should be mounted 0.3-0.5 mm over the tape center. This measure is referred to the tape center to avoid erasing on track 2 which could be caused by the stray field of the magnet.

For adjustment use a gauge made by yourself. This gauge is made of a thin strip of hard paper 6.25 mm broad or a similar material which does not damage the gap of the head. Onplace of the erase head make a suitable cutout, the lower edge of which may be 0.3 mm over the center. Adjust the erase head in recording position that it is moved $\pm 2^\circ$ max. referred to the adjustment of 12° as per fig. 1 which can be caused by moving air when stopping. The erase head is located in its adjusted position by means of counter nuts pos. 31.

The driving chain can be stretched a small amount by setting the adjustable boss buffer pos. 32.

The stop bolt pos. 34 on the slider pos. 33 serves for lifting the pressure roller lever pos. 35 in position **stop** and **rewind**. Adjust the stop bolt in positions **playback** or **recording** until the distance between stop bolt and the pressure roller lever reads 0.2 - 0.3 mm. So adjusted the pressure of the pressure roller pos. 36 to the capstan of the flywheel reads 450 - 500 gr., it is measured by means of a Spring Balance at the spring hang-in hole marked "M".

The tape pull reads in positions **playback** or **recording** ≥ 100 gr.

The screws pos. 37 can be used to set the pressure roller absolutely vertically in accordance to the pos. of the capstan of the flywheel. The screw with pressure spring serves for stabilizing and should be secured after the adjustment has been finished.

The screw pos. 38 serves for the vertical adjustment of the gap of the recording head when adjusting the head electrically. The opposite screw with pressure spring serves for stabilizing and should be secured after the adjustment has been finished.

TOP VIEW OF CASSIS

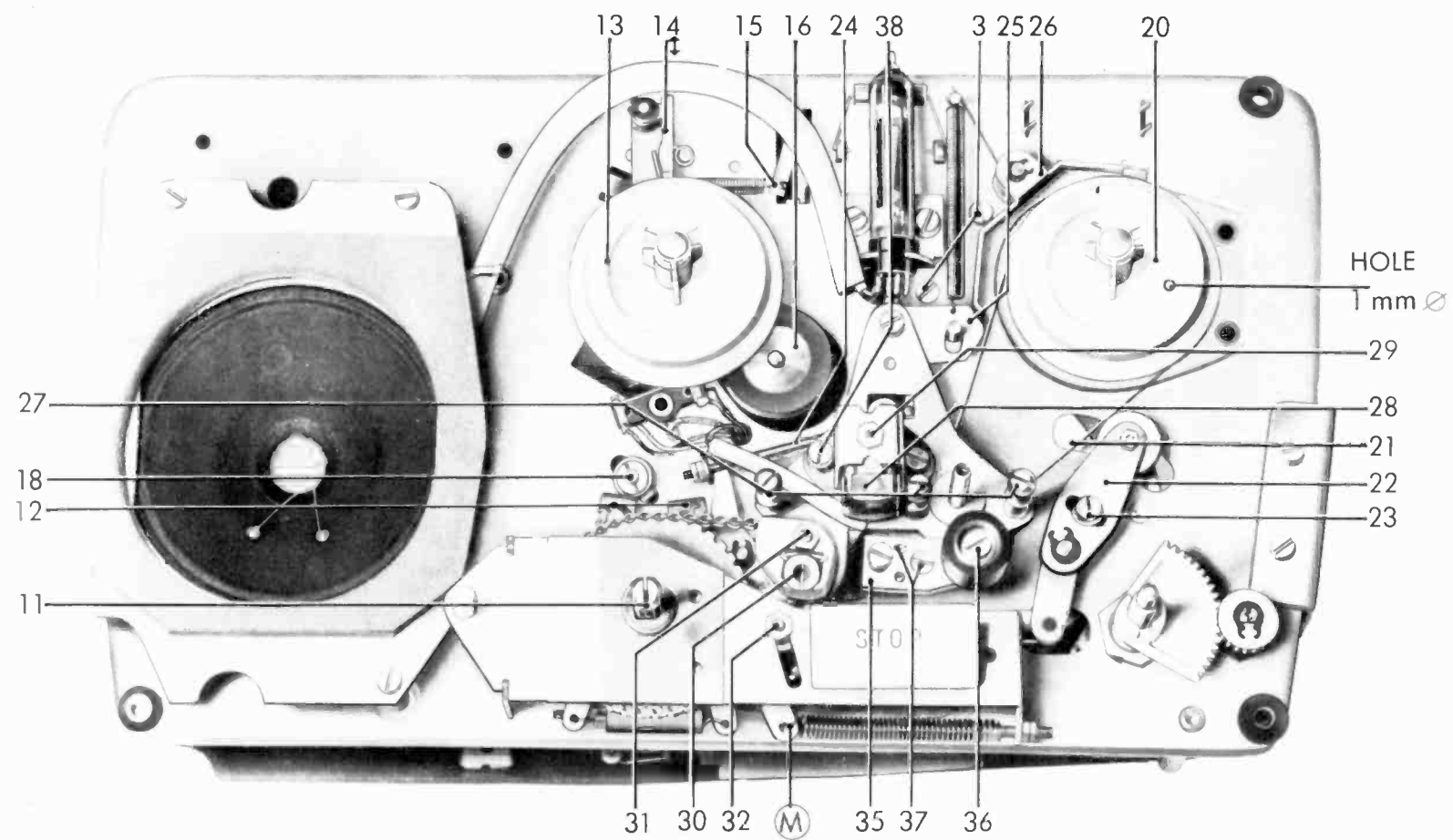

BOTTOM VIEW OF CHASSIS

PLUG-IN CONNECTIONS 1...9

SOLDER CONNECTIONS
12 13 14 15

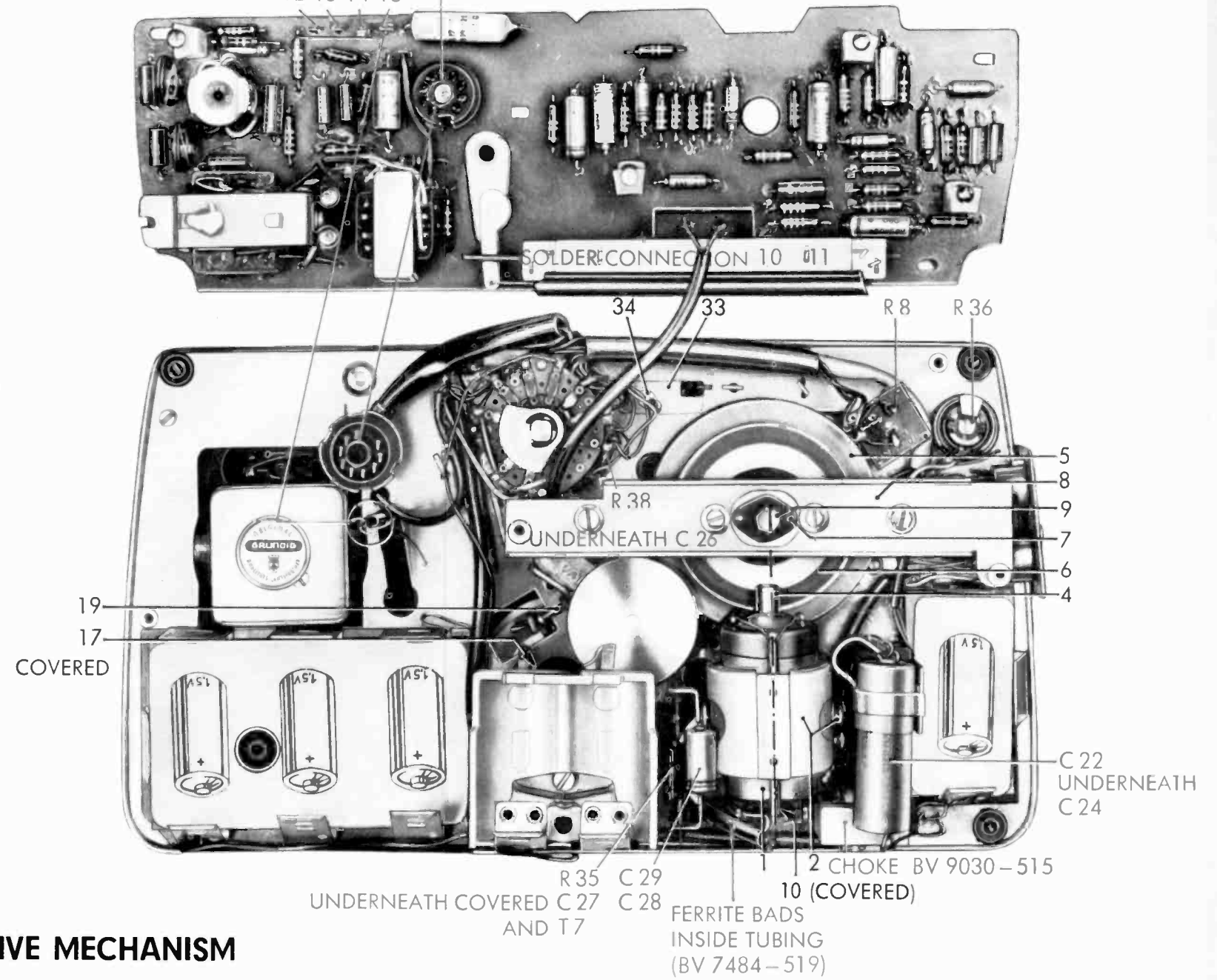

FIGURES, HOW TO ADJUST THE TAPE DRIVE MECHANISM

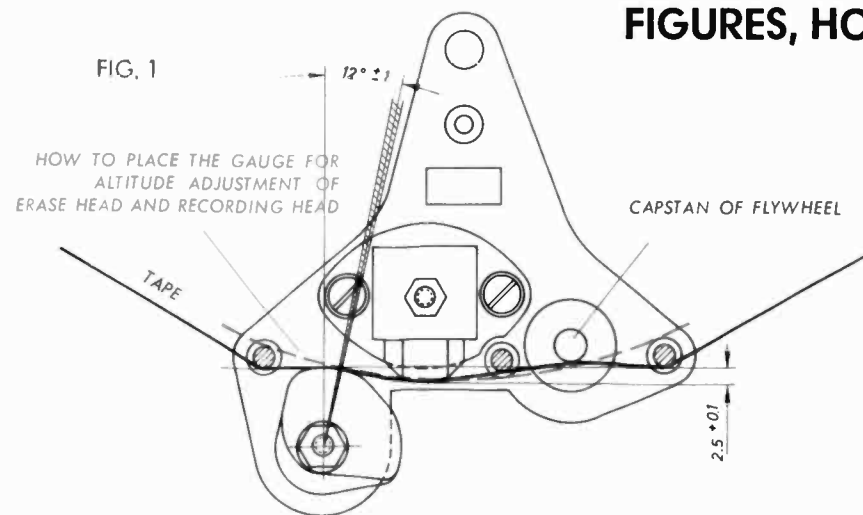
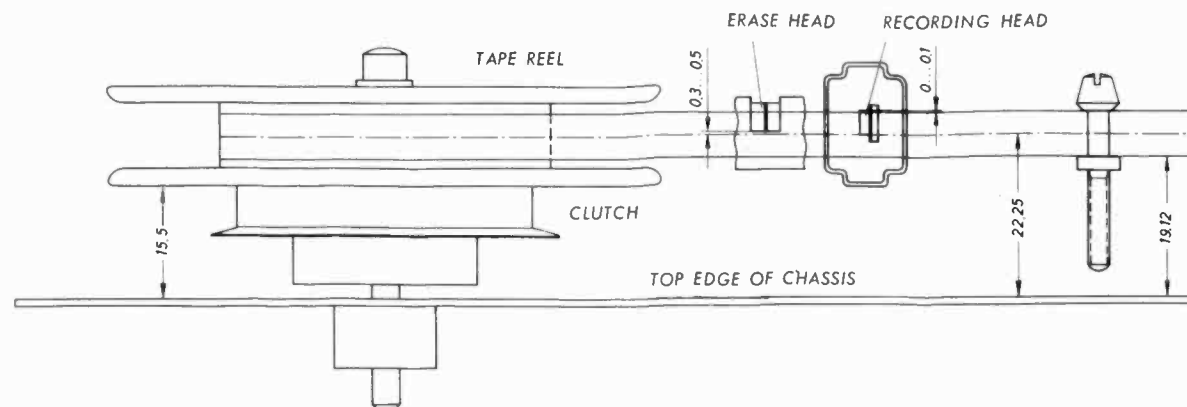
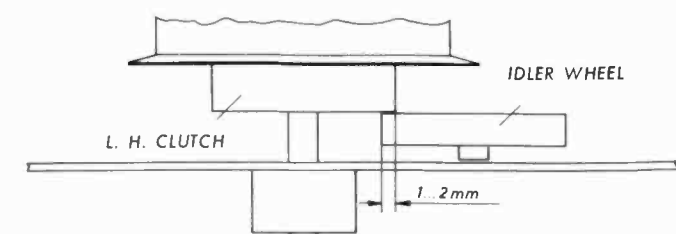

FIG. 2



HOW TO ADJUST THE REWIND IDLER WHEEL

FIG. 3



VIEWS OF THE MECHANIC CHASSIS



P. T. O. ELECTRONIC CHASSIS



P. T. O.

VIEWS OF THE
MECHANIC CHASSIS

ELECTRONIC TEST INFORMATION

PRINTED CIRCUIT
SOLDER SIDE

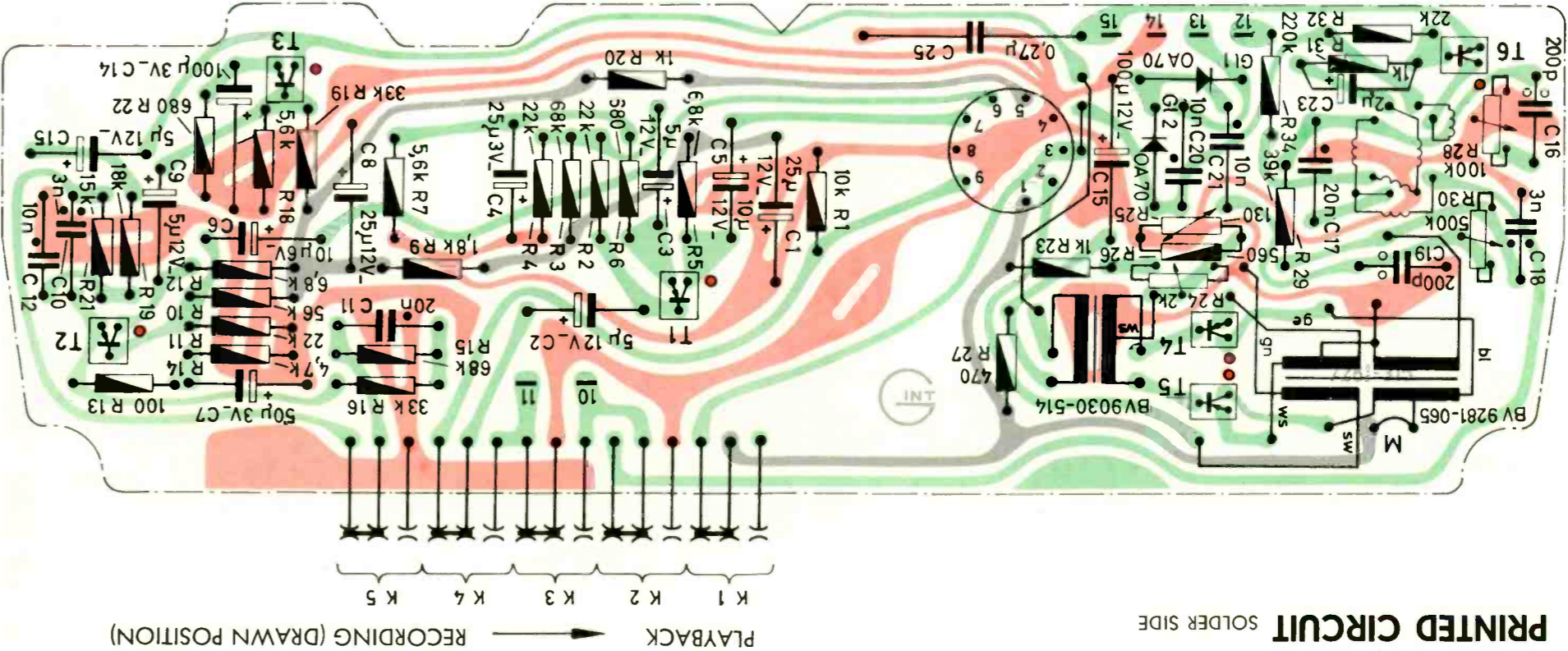

TRANSFORMERS

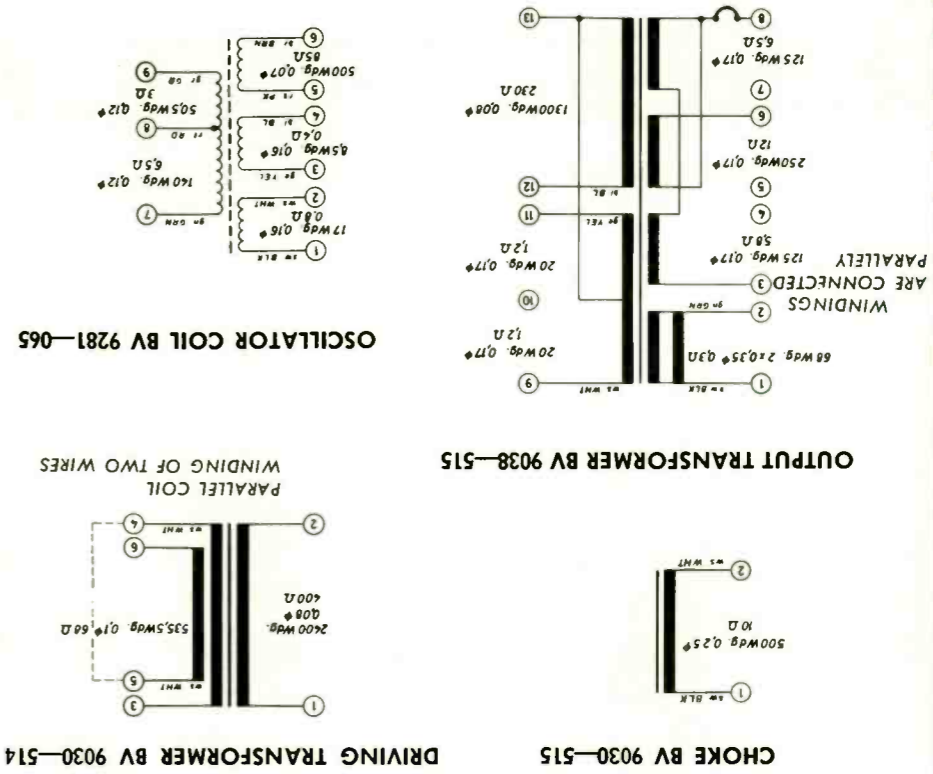

WIRING

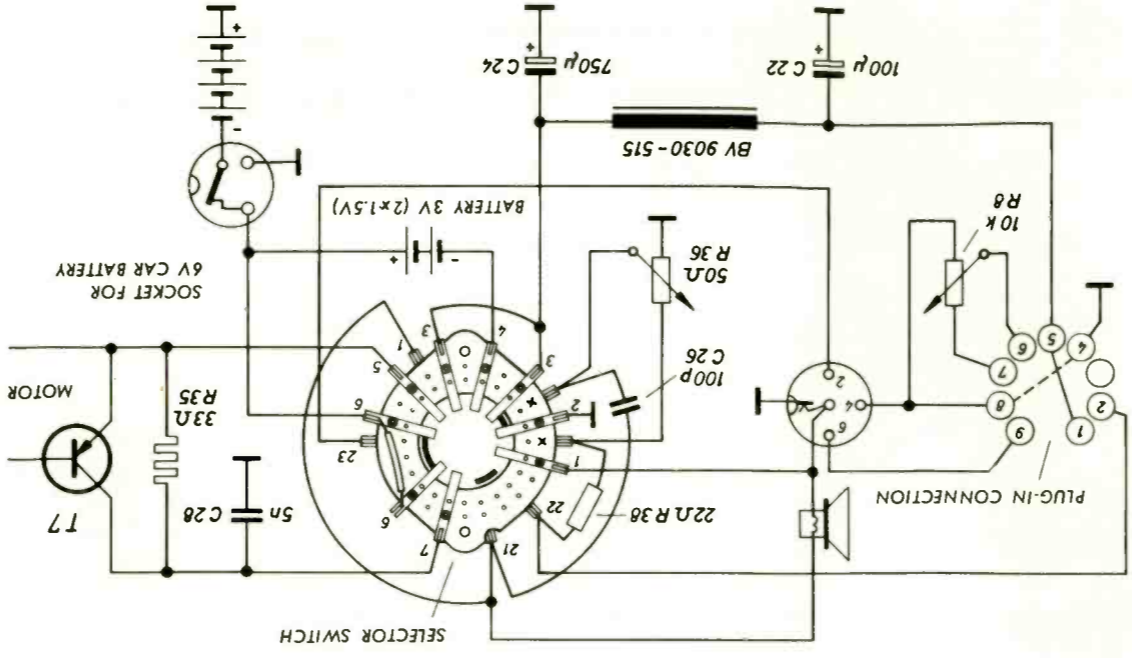

TEST CIRCUITS

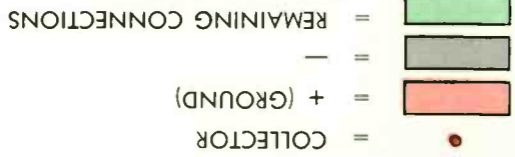
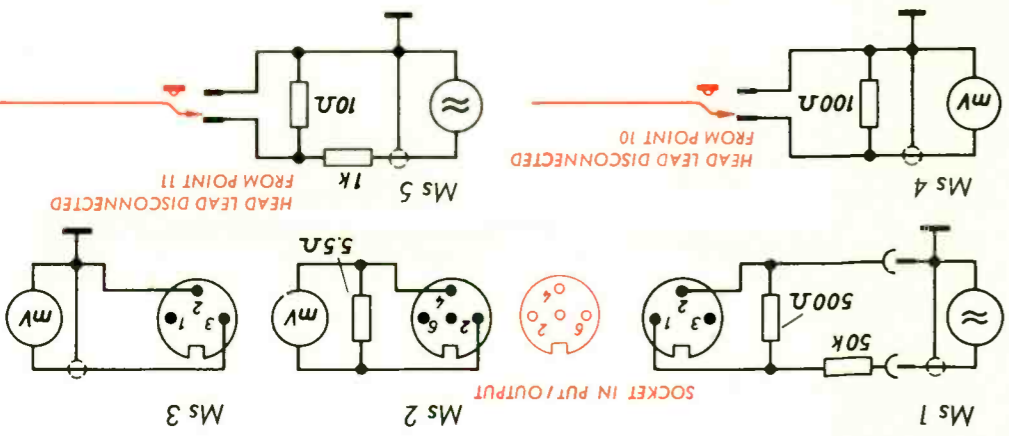
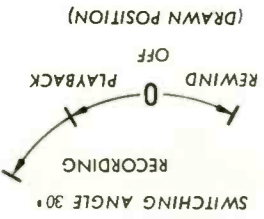

DIAGRAM OF THE SELECTOR SWITCH

RECORDING	1/2	2/3	3/4	5/6	6/7	21/22	21/23
STOP							
PLAYBACK							
RECORDING							



Sets from the serial no. 10,500 (approx.) are equipped with a differently assembled motor assy. Please, observe carefully on replacement. With motor assemblies up to serial no. 10,500 the motor roller is situated on the side of the terminals for the speed control unit. With motor assemblies from serial no. 10,500 the motor roller is situated on the side of the terminals for battery connection. Please, observe the colour coding and the figures below:

red = battery connection
green = speed control unit connection

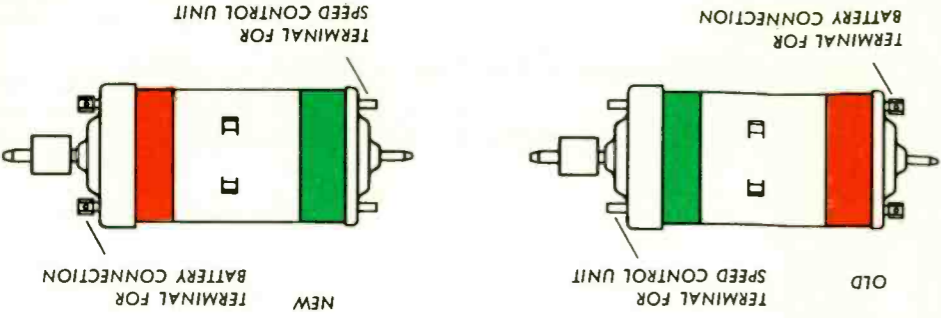

ALTERATION

Measuring Values

Following measuring values are taken from test information given for manufacturing purposes. When measuring you can find out easily whether the set works under the terms requested from the factory or not.

Measurement of AF and RF voltages and currents should be carried out with Valve Voltmeter RV 54. For oscillographic tests we recommend Oscilloscope G 4. Frequency response, amplifier and frequency correction network should be measured with GRUNDIG Radio Signal Generator 295. Direct voltages should be measured with one of the GRUNDIG Valve Voltmeters RV 2, 3, or 11 and direct currents with a multi-purpose appliance (Multavi 5).

Input voltages are measured before a potential divider as per Ms 1 and 5. Head currents are measured as a potential drop in mV at a resistor of 100 Ω in the head return lead as per Ms 4. Output voltages are measured parallel to a load resistor of 5.5 Ω or directly as per Ms 2 and 3.

Transistors

The measuring values are referred to an amplifier direct current of 9 volts. To obtain the demanded values of the test information it is necessary in all circumstances to equip the amplifier of the set with transistors of one of the four groups as follows:

	group 1	group 2	group 3	group 4
1st stage T 1	TF 65	with white collar (of low noise level) for all colour groups		
2nd stage T 2	TF 65	blue } or { green } or { yellow }		orange }
3rd stage T 3	TF 65	blue } or { blue } or { violet }		gray } or { brown }
4th stage T 4 + 5	OC 72	current amplification 45 ... 120 at U _c : 5.4 V / J 6 10 mA		
oscillator T 6	5 OC 74	current amplification as per data sheet		

Index of adjustable Controls

For positions see mechanical views.

Recording level control and volume control on playback	R 8	10 k Ω
Spacing current control of the output stage	R 24	2 k Ω
Bias-magnetizing control	R 28	100 k Ω
Control for recording indicator	R 30	500 k Ω
Monitoring control on recording and tone control on playback	R 36	50 Ω

Power Consumption

Measure with tape, with a full tape reel on the left-hand clutch by means of a currentmeter, disconnect battery at mark "++".

Recording	250 mA max.
Playback	285 mA max.
Rewind	310 mA max.

How to adjust the Spacing Current for the Output Stage

For measuring purpose connect a currentmeter to the negative lead of the output transformer (measuring point M). For adjustment serves control R 24, it is adjusted in position playback without signal at the input to 6 mA.

Attention: When disconnecting the negative lead be sure to switch off the set otherwise the transistors are destroyed, because the collectors of the output stages are without connection.

RF-Generator

For measurement as per Ms 4 disconnect at point 10. Adjust by means of control R 28.

The bias-magnetizing reads 1.15 mA (= 115 mV at 100 Ω)
Frequency 38 ... 42 kc

The (RF) anode voltage for tube DM 71 reads ≥ 70 V

Recording Channel

The input voltage is indicated before a potential divider of 50 k Ω / 500 Ω as per Ms 1, the connection is made to the points 6 - 4 of the input / output socket. The output voltage is measured in recording position as potential drop as per Ms 4 at an 100 Ω resistor which should be inserted into the head return lead. Disconnect the oscillator by removing valve DM 71. Set R 8 to its full level and close R 36 completely.

Amplification

At a constant input voltage of 10 mV
the potential drop at 100 Ω and 1,000 cps reads 5.5 mV \pm 2 db.

Frequency Response

Referred to a measurement at 1,000 cps you get at an allowable deviation of \pm 2 db at

333 cps at	5.65 mV = + 0.2 db
4,000 cps at	9 mV = + 4.3 db
8,000 cps at	15.1 mV = + 8.8 db

External Voltage

Disconnect the audio generator as per Ms 1, by that the input is terminated by a resistor of 500 Ω . Measure parallel to the recording head as per Ms 3.

Volume control at full level	14 mV
Volume control completely closed	3 mV

Magic Level Indicator

Insert tube DM 71. Increase input voltage at 1,000 cps until you get at 100 Ω 15 mV, thereby at the grid of the tube DM 71 a negative direct current should be measurable by a Valve Voltmeter. For re-adjustment use control R 30.

Playback Channel

The input voltage is measured before a potential divider of 1,000 / 10 Ω + recording head as per Ms 5, feed into the head lead which is negative on playback. The output voltage is measured parallel to a resistor of 5.5 Ω which should be connected as per Ms 2 at the input / output socket (2-4). Disconnect one connection lead of the loudspeaker during this measurement, it can also be done by using a special plug with a center pin. Set the volume control to its full level and the tone control to the position "treble boost".

Amplification

At a constant input voltage of 10 mV
are at 5.5 Ω at 1,000 cps 68 mV \pm 2 db

Frequency Response

Referred to a measurement at 1,000 cps you get at an allowable deviation of \pm 2 db at

333 cps	120 mV = + 5 db
4,000 cps	71 mV = + 0.4 db
8,000 cps	180 mV = + 4 db

At the same measurement as already described but with the tone control set to "low notes" you get at

1,000 cps 27 mV = + 11 db
Referred to a measurement at 1,000 cps you get at an allowable deviation of \pm 3 db at

333 cps	96 mV = + 11 db
4,000 cps	14 mV = — 5.7 db
8,000 cps	15 mV = — 5 db

External voltage

Short circuit the recording head and set the tone control to "trebles notes". Now, the max. interference voltage may read:

with the volume control set to full level 2.1 mV
with the completely closed volume control 0.6 mV

Measurement with Tape

Feed as per Ms 1 as described in section Recording Channel, input voltage 5 mV. Measuring frequencies 1,000 cps, 333 cps, 4,000 cps, and 8,000 cps.

The output voltage is measured at the input/output socket (2 - 4) parallel to the loudspeaker as per Ms 3.

Monitoring Control

During a recording are at the loudspeaker 19 mV + 3 db.

Amplification

The output voltage of a correctly levelled recording may read at 1,000 cps 295 mV minimum, the volume control is set to full level and the tone control is set to "trebles notes".

Frequency Response

Turn the volume control back until you get 245 mV at a 1,000 cps playback. Referred to the measurement at 1,000 cps following deviations should be obtained

at 333 cps ± 3 db
at 4,000 cps ± 3 db
at 8,000 cps ± 5 db

External Voltage

Reads at an adjustment as already described 3.5 mV.

Tape Run

Tape speed on playback and recording in the middle of the tape,

at 6 V constantly

9.53 cm/sec. $\pm 2.5\%$

at over voltage of 7.5 V

9.53 cm/sec. $\pm 3-2.5\%$

at undervolting of 4.3 V

9.53 cm/sec. $\pm 2-3\%$

With less than 4.3 volts the automatic speed control unit for the motor assy. fails.

The loaded motor makes at 6 volts 3,000 revolutions per minute. It can be measured by means of a stroboscopic disk with one bright and one dark field. The stroboscopic disk should be illuminated by a glow lamp or a fluorescent lamp which is connected to a 50 cps mains supply. So you can find out whether the motor makes 3,000 revolutions or not. At correct revolutions the stroboscopic disk seems to stop. If the fields are moving in direction of rotation the motor is running to fast and to slow if the fields are moving in opposite direction.

Departure from synchronism may not increase more than $\pm 0.5\%$, valued acoustically.

Notes:

Handwriting practice lines consisting of 18 horizontal dotted lines.

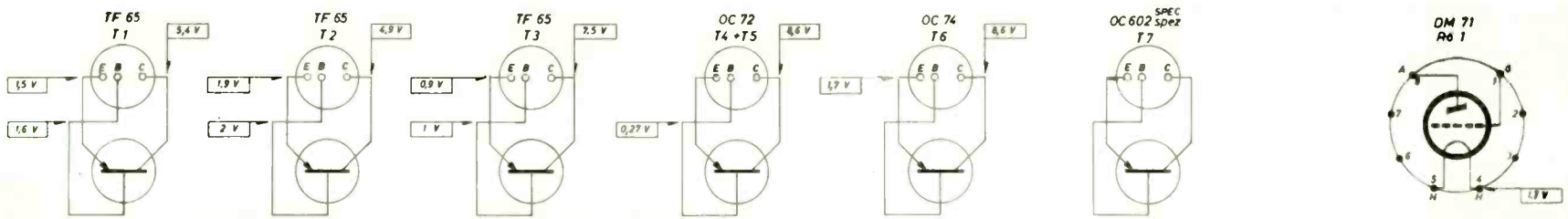
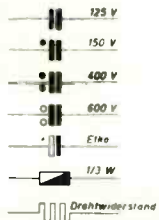

INPUT / OUTPUT SOCKET VIEWED FROM REAR
 Mikro / Diodes
 Buchse von hinten gesehen

RECORDING HEAD PART NO 7489-040
 Hör - Sprechapp
 Zch Nr 7489-040
 BV 9281-055



PRINTED PLATE OF AMPLIFIER
 Verstärkerdruckplatte
 Zch. Nr. 7281-015

CENTRIFUGAL SWITCH
 Motor - Repter
 BV 7484-519
 2 BEADS
 2 Perlen
 C 27
 5nF

THE CONTACT OPENS WITH INSERTED PLUG
 geöffnet bei Ansteckung an äußere Spannungsquelle
 Buchse für Motor spannungsquelle (6 V)
 SOCKET FOR EXTERNAL SUPPLY

Handlakte:	K4	K3	K2		K5		K1		CONTACTS																						
C	1,2	3,4	5	6	8	7,10,11	9	12	16	14,13,17	15	23	25	20	18	21	19	21,23	22,21	1,2	3	2,4	7,6	5,6							
D	1	3	2,4	6,7	5	8,8	10	11	16,13,14	15	12	19	21	18	20	22,17,20	27	29,34	31	24,23	32,26	25	30	28,36	26	22	24	29	28	27	C
																														R	

16161 Ze

P. T. O.
 POWER
 PACK
 FOR TK 1
 TK 1 E



CIRCUIT
 DIAGRAM
 TK 1
 TK 1 E
 39-5061-1000
 ind. 03

CIRCUIT DIAGRAM

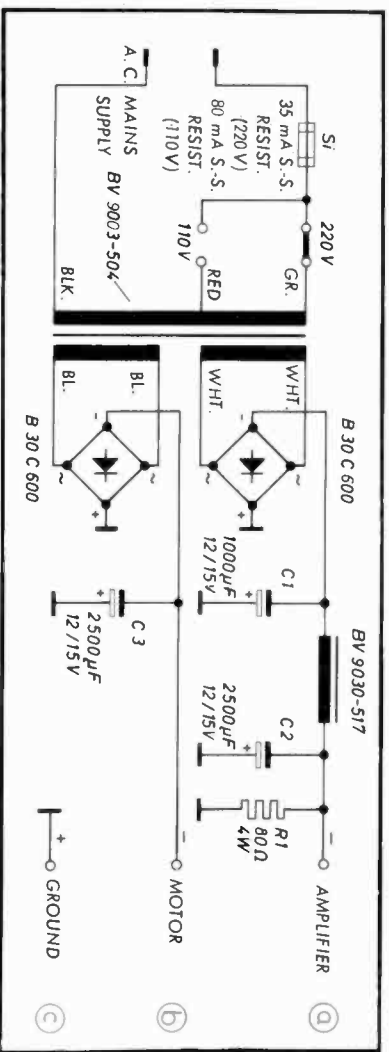

**POWER
PACK
FOR TK 1
TK 1 E**

MEASURING VALUES

Following measurements are referred to 220 V \pm 2% at 50 cps. During measurement both outputs are terminated by equivalent resistors simultaneously. By that you get the same ratio of load as with a connected TK 1.

Equivalent Resistors

for the motor assy. 30 Ω 2 W, interconnect connectors a and b
for the amplifier 220 Ω 1/2 W, interconnect connectors a and c

Following measuring values should be obtained:

power consumption 29.5 mA \pm 10 %
voltage of motor at 30 Ω 6.17 V \pm 7.5 %
voltage of amplifier at 220 Ω 9.3 V \pm 7.5 %

The hum voltages (remaining ripple) may read measured by means of a Audio-Frequency

Valve Voltmeter : at 30 Ω 140 mV
 at 220 Ω 5.5 mV

TOP VIEW OF POWER PACK

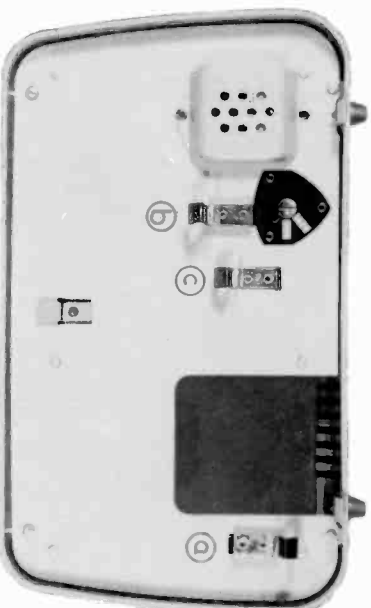

TRANSFORMERS

MAINS TRANSFORMER BV 9003-504

CHOKE 9030-517

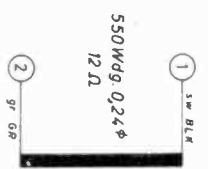
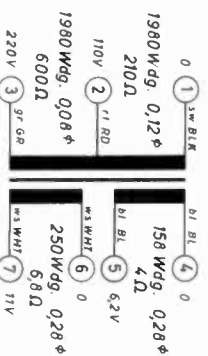

Pos.-Nr. Code-No.	Bild-Nr. Fig. No.	Benennung Nomenclature	Bestell-Nr. Part-Number	Bemerkungen Remarks
1	2	Chassis kpl.	5061-021	
2	3	chassis assy	5061-029	groß
3	3	Batteriehalter kpl.	5061-033	large
4	3	Batteriehalter kpl.	5061-199	klein
5	3	Batteriehalter kpl.	5050--296	small
6	3	Batteriehalter kpl.	5061-193	
7	2	Spulenteller kpl.	5061-210.01	links elfenbein
8	2	spool carrier assy	5050-061	left-hand, ivory
9	2	Arretierungsring	9604-533	2x
10	2	reel retaining ring	9604-533	4x (4.2 x 8.5 x 0.5) Hp.
11	2	Scheibe	5061-035	
12	2	washer	9604-598	
13	2	Bremshebel kpl.	5061-037	(3.2 x 7 x 0.5) Hp.
14	2	brake lever assy	5061-038.01	
15	2	Scheibe	9604-349	Oberteil elfenbein
16	2	washer	5061-043	upper part, ivory
17	2	Kupplung kpl.	5061-050	3x (4.2x9x0.5)
18	3	clutch assy	5061-052	simrit
19	3	clutch assy	5061-054	Unterteil
20	3	Einsteilring	5061-182	lower part
21	3	adjusting ring	5061-062	für Nr. 15
22	3	Blatfeder kpl.	5061-065	2x mit Filzklotz
23	2	leaf spring	9613-025	2x c/w felt pad
24	3	Filzklotz	2 x 6 DIN 1476	2x für Nr. 21
25	3	felt pad	5061-066	2x für Nr. 21
26	3	Schwingscheibe kpl.	3 Kl. III	2x für No. 21
27	3	flywheel	9604-802	4.1 x 7.5 x 0.3
28	3	Scheibe	5061-067	Federbandstahl
29	2	washer	5061-070	
30	3	Schiene kpl.	9631-828	
31	2	bar assy	5061-071	
32	2	Flachriemen	5061-072	
33	2	flat belt	5061-074	
34	2	Rundriemen	5061-077	
35	2	drive belt	5061-078	
36	2	Riemenspanner kpl.	9604-716	(3.2 x 7.5 x 1)
37	2	stretcher assy	5050-046	
38	2	Rolle kpl.	5061-080	
39	2	roller	5061-081	
40	2	Zugstange	5061-142	
41	2	pull rod	5061-082	
42	2	Schwenkhebel	5061-007	

Pos.-Nr. Code-No.	Bild-Nr. Fig. No	Benennung Nomenclature	Bestell-Nr. Part-Number	Bemerkungen Remarks
43	2	Drehfeder	5061-084	
44	2	torsion spring Brücke kpl. bracket assy	5061-085	
45	2	Wippe	5051-087	
46	2	whip, recording safety Blattfeder	5061-088	
47	2	leaf spring Zapfen	5061-097.01	
48		recording safety button Bolzen	5061-089	elfenbein für Nr. 44 for No. 44
49	2	bolt Rolle	5061-189	
50	3	roller Schaltwelle	5061-090	
51	2	selector switch spindle Kettenrad	5050-097	
52		sprocket wheel Rastscheibe	5061-091	22,5 ϕ
53		engaging disk Abstandsrohr	5061-092	6 mm stark
54		spacer Abstandsrohr	5061-093	3,5 mm stark
55	2	spacer Doppelkurve	5061-094	
56		cam, double — Kurve	5061-095	Rücklauf
57	3	cam, fast rewind switching cam	5061-096	
58		Abstandsrohr	9606-702	2 \times (Polystrol)
59	3	spacer Schaltenebene kpl.	7690-058	
60	2	switch wafar assy Schieber	5061-098	
61	2	slider Druckfeder	5061-099	
62	1	compression spring Taste	5061-102.01	elfenbein
63	2	press button Zugfeder	5061-103	ivory 40 Wdg.
64		tension spring Zugfeder	5061-104	48 Wdg.
65	2	tension spring Funktionsschieber kpl.	5061-105	
66		selector slide Anschlagbolzen	5061-107	für Nr. 65 for No. 65
67	2	stop bolt Rasthebel kpl.	5061-108	
68	2	lock lever assy Rasthebel kpl.	5061-110	
69	2	lock lever assy Zugfeder	5061-112	
70		tension spring Bolzen	5061-113	
71	3	bolt Rücklaufhebel kpl.	5061-114	2 \times für Nr. 67 und 68 2 \times for No. 67 and 68
72	2	fast rewind lever assy Scheibe kpl.	5061-118	mit Reibring
73	3	washer assy Riemenscheibe	5061-122	
74		drive pulley (idler wheel) Bundbolzen	5061-123	25,5 mm lang
75		tape guide Zugfeder	5061-124	43 Wdg. für Nr. 65
76	2	tension spring Halter	5051-125	
77	2	bracket (DM 71) Spannfeder	5061-126	
78	2	torsion spring Röhrenfassung 8-pol.	4689	
80	2	tube socket, 8-prong — Anschlußplatte kpl.	9610-798	
81	2	socket panel assy Bandführungsbolzen	5061-132	3 \times
82		tape guide Bolzen	5061-133	auf der Kopfrägerplatte 33,2 mm lang
83	2	bolt Hebel kpl.	5061-188	
84		lever Kettenrad	5050-112	
85	2	sprocket wheel Kopffulage head fulcrum	5014-094	auf der Kopfrägerplatte

Pos.-Nr. Code-No.	Bild-Nr. Fig. No.	Benennung Nomenclature	Best. Nr. Part-Number	Bemerkungen Remarks
86		Druckfeder compression spring	5061-141	
87	2	Kopfhalter kpl. head mounting assy	5061-207	6.5 Wdg.; auf der Kopfrägerplatte
88		Druckfeder compression spring	9619-520	
89	2	Halbspur-Kombikopf rec. / playback head Löschkopf-Halter kpl. erase head assy	7489-040	auf der Kopfrägerplatte. 7 Windg. on head mounting panel (Sprechkopf)
90	2	Andruckrolle pressure roller assy	5060-042	
91	2	platte panel	5061-180	
92	2	platte panel	5061-138	
93		Bolzen bolt	5061-139	17.3 mm lang auf der Kopfrägerplatte
94		Scheibe washer	9604-618	2 x (4.1 x 7.5 x 0.5) Hp.
95		washer Druckfeder compression spring	9619-528	5 Wdg. für Nr. 93
96	2	Bandkette chain	5061-140	
98	3	Motorhalter kpl. motor bracket assy	5061-147	
99	3	Motorbrücke kpl. motor bridge assy	5061-149	
100	3	Gummiring rubber ring	5061-176	für Nr. 105
101		Zugfeder tension spring	5061-146	56 Wgd. für Nr. 105
102	3	Schiebebügel sliding bracket	5050-130	
103	3	platte plate	5061-152	Moosgummi
104	3	Abschirmung screening	7882-575	
105		Kleinformotor kpl. motor assy	7882-082	
106	3	Abschirmkappe screening cap	7882-614	
107		Kühlschelle clamp	9602-107	für Transistoren am Motor for transistor m. Flanschdose 2pol. u. 3pol. with socket für Nr. 108
108	2	Buchsenwinkel kpl. socket bracket assy	5061-153	
109	2	Flanschdose 2-pol. 2-pin socket	6164	
110	2	Flanschdose 3-pol. 3-pin socket	T 3270	für Nr. 108
111		Scheibe washer	9604-553	8 x (3.2 x 9 x 1.5) Hp
112	2	Novol-Stecker novol plug	9622-162	
113		Abschirmplatte screening panel	5061-181	Hartpapier unter Druckplatte
114	2	platte panel	5050-271	
115	2	Lautsprecher loudspeaker	7012-001	
116		Krampe clamp	9602-041	für Nr. 115 for No. 115
117	2	Abstandsrohr spacer	5050-172	3x
118	1	Abdeckplatte kpl. top deck	5061-159.01	mit Schriftzug, elfenbein with nameplate, ivory
119	1	Schriftzug nameplate	5061-217.01	
121	1	Abdeckung head cover	5061-162.01	elfenbein ivory
122	1	Koffer kpl. cabinet assy	7682-110.01	
125	1	Steckscharnier kpl. open hinge assy	! 7682-651	2 x Messing, poliert brass, polished
126		Schließblech lock panel		unten 2x
127	1	Schließplatte lock plate	7682-679.01	below
128		Lasche lashing	7682-739	eierschalenfarbig
129	1	Handgriff handle	7682-764.01	Halterung zwischen Zarge und Boden
130	1	Kappe cap	7682-655	eierschalenfarbig
131	1	Maske plastic escutcheon for sockets	7682-811.01	2 x Messing, poliert brass, polished elfenbein ivory

Pos.-Nr. Code-No.	Bild-Nr. Fig. No.	Benennung Nomenclature	Bestell-Nr. Part-Number	Bemerkungen Remarks
132		Bodennagel bottom nail	9631-034.01	2x messing brass
134		Gummipuffer rubber buffer	7682-742.01	4x beige
135		Linsenschraube deck screw	7682-743.01	messing poliert brass, polished
136		Kappe cap	7682-744	im Boden, Messing
137		Scheibe washer	7682-760	für Nr. 136 for No. 136
138		Kissen frame rubber pad	7682-761	im Boden, groß
139		Kissen frame rubber pad	7682-771	im Boden, klein
140		Kissen frame rubber pad	7682-895.01	im Boden, rechteckig
142		Gitter grid	7682-749.01	im Boden
143	1	Schwert lock piece	7682-738	im Boden in bottom messing brass
144	1	Griffleiste handle bar	9628-693.01	weinrot, messing red, brass
145	1	Wappen, Krone crown	5061-215.01	weinrot red
146	1	Schild nameplate	5060-019	8x
148		Krampe cramp	5050-160	3x
149		Bolzenmutter bolt nut	9604-764	4x
150		Scheibe washer	9604-755	4x (4.3 x 10 x 1)
151		Scheibe washer	5050-132	4x
152	2	Tülle grommet	5061-164	
153	1	Folienruckbild operating instruction label	5061-215	deutsche Beschriftung german lettering
153		Folienruckbild operating instruction label	5061-168.01	englische Beschriftung english lettering
154	1	Hebelgriff kpl. lever handle assy, selector switch	5050-171	links elfenbein L. H., ivory
156		Scheibe washer	5061-172.01	2 x Filz 11 X 17
157	1	Drehknopf kpl. knob, small (sensitivity control)	5050-121	rechts, elfenbein R. H., ivory
158	2	Zahnsegment gear segment	5050-120	
159	2	Zahnrad gear wheel	5061-171.01	rechts R. H.
160	1	Hebelgriff kpl. lever handle assy, volume control	5061-014	
161		Karton mit Einlage carton with fittings	0608-187	
162		Mikrofon Dose microphone container	OC 602	
163		Transistor		
164		Elko electrolytic capacitor		100 µF 12/15 V
165		Elko electrolytic capacitor		100 µF 15/18 V
166		Elko electrolytic capacitor		100 µF 6/8 V
167		Elko electrolytic capacitor		750 µF 12/15 V
168		Elko electrolytic capacitor		1000 µF 12/15 V
169	3	electrolytic capacitor	7885-018	KN 5018 10 kΩ
170	3	Potentiometer volume control	7885-019	KN 5019 50 kΩ
171		Regler min. pre-set Drosselspule choke coil	BV 9030-515	
Zum Verstärkerchassis 7281-015				
for amplifier chassis 7281-015				
173	3	Verstärkerchassis kpl. amplifier chassis	7281-015	ohne Transistoren without transistors
174	3	Pico-9-Röhrenfassung tube socket, pico-9	6787	
175		Subminiatur-Transistorfassung min. transistor-socket	6891	6x
176	3	Schiebeschalter — switch	7281-530	

Pos.-Nr. Code-No.	Bild-Nr. Fig. No.	Benennung Nomenclature	Bestell-Nr. Part-Number	Bemerkungen Remarks
177		Oszillator kpl. — oscillator assy	5061-194	
178		Bügelhalter — bracket for oscillator	B 655 65	Re 1 B Siemens
179		Zugfeder — tension spring	7281-532	92 Wdg.
180	3	Hebel — lever	5050-135	
181	3	Kühschelle — clamp	9602-118	
182	3	Transistorbett — transistor socket	9614-265	stehend 4 × standing 4 ×
183		Scheibe — washer	9604-547	
184		Germaniumdiode — germanium diode	OA 70	
185		Elko — electrolytic capacitor		2 µF 30/35 V
186		Elko — electrolytic capacitor		5 µF 12/15 V
187		Elko — electrolytic capacitor		5 µF 15/18 V
188		Elko — electrolytic capacitor		10 µF 6/8 V
189		Elko — electrolytic capacitor		10 µF 12/15 V
190		Elko — electrolytic capacitor		10 µF 30/35 V
191		Elko — electrolytic capacitor		25 µF 3/4 V
192		Elko — electrolytic capacitor		25 µF 12/15 V
193		Elko — electrolytic capacitor		25 µF 15/18 V
194		Elko — electrolytic capacitor		50 µF 3/4 V
195		Elko — electrolytic capacitor		50 µF 6/8 V
196		Elko — electrolytic capacitor		100 µF 3/4 V
197		Elko — electrolytic capacitor		100 µF 12/15 V
198		Elko — electrolytic capacitor		100 µF 15/18 V
199		Widerstandstrimmer		2 kΩ (R 24)
200		trimmer resistor		100 kΩ (R 28)
201		Widerstandstrimmer		500 kΩ (R 30)
202		Widerstandstrimmer		130 kΩ (R 25)
203		Heißleiter — thermistor	5050-073	
204		Treibtrafo — driving transformer	BV 9030-514	
205		Ausgangsübertrager	BV 9038-515	
206		output transformer		
207		Oszillatortransformator	BV 9281-065	
209		Oszillatortransformator	BV 9281-065	
210		Oszillatortransformator	TF 65	
211		Oszillatortransformator	TF 65	

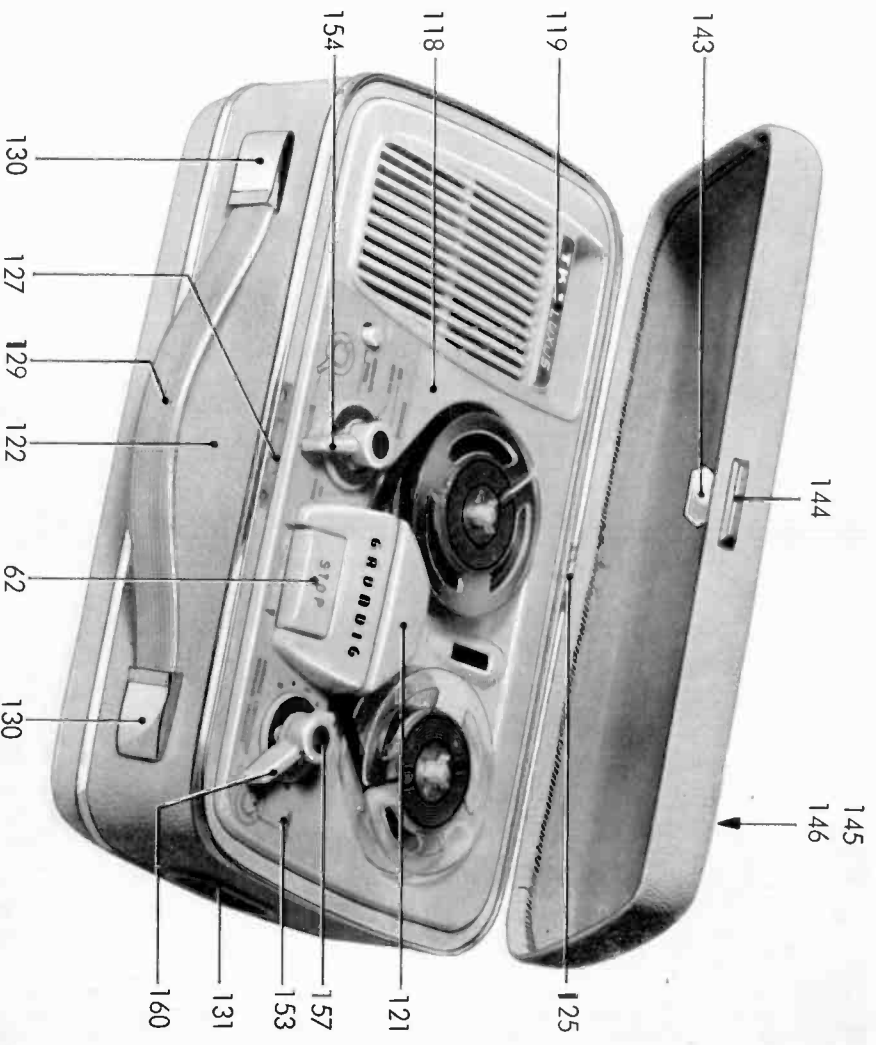

Figure 1

INDICATED NUMBERS ARE CODE NOS OF THE PART LIST

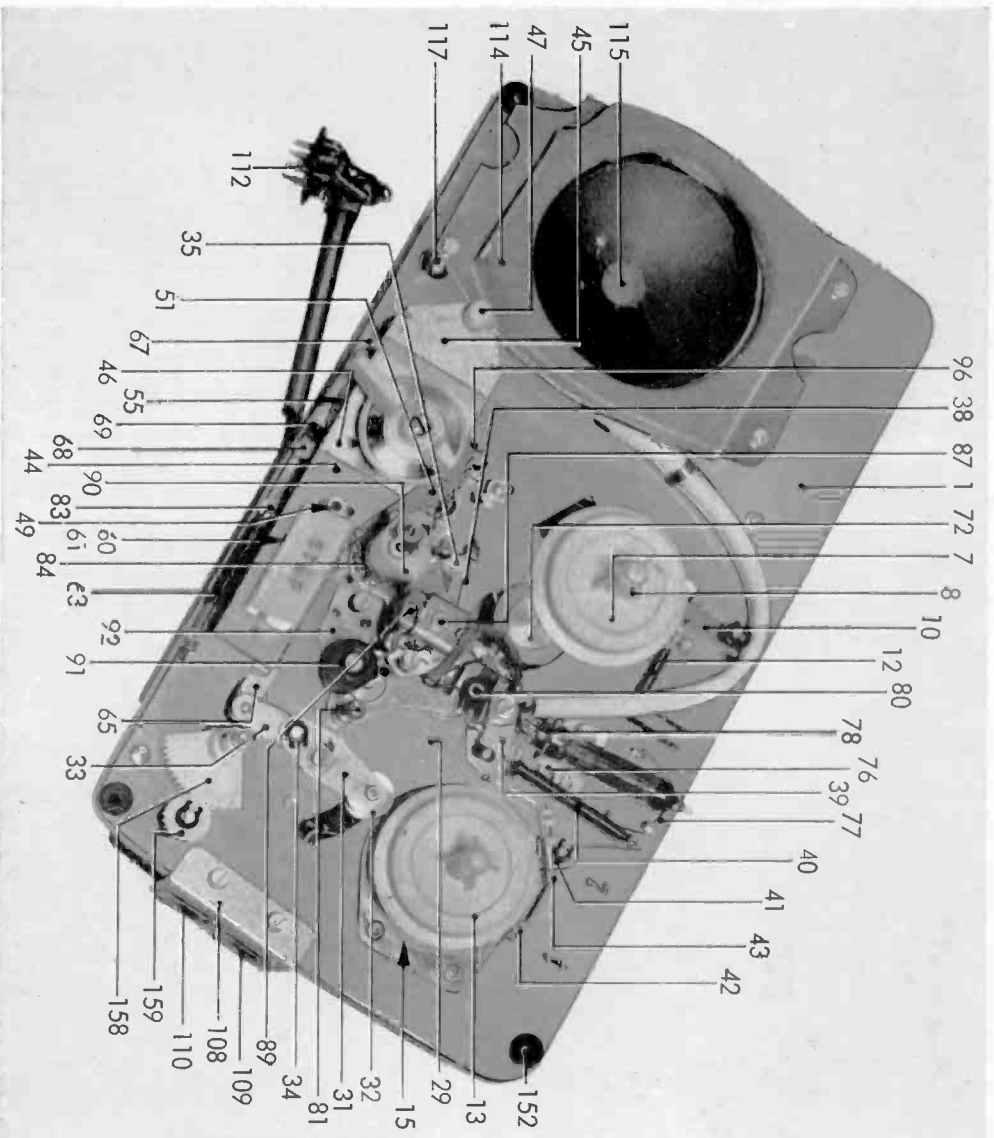

Figure 2

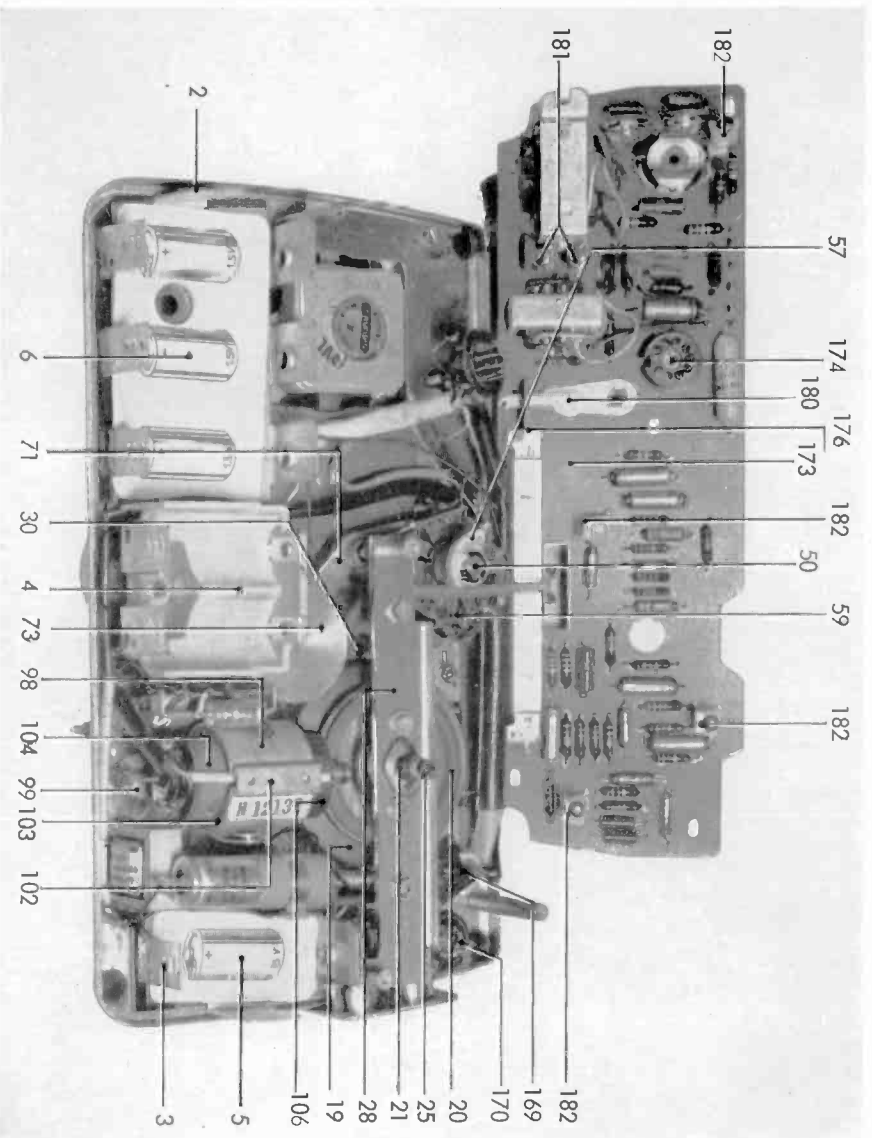

Figure 3

INDICATED NUMBERS ARE CODE NOS OF THE PART LIST