

CONFIDENTIAL
FACTUAL
REPORT
 SCHEMATICS ETC.

ACKNOWLEDGEMENTS

SECRET CB WISHES TO GRATEFULLY ACKNOWLEDGE THE FOLLOWING PEOPLE FOR THEIR HELP AND CONTRIBUTIONS TOWARD GETTING VOLUME 15 IN PRINT. THEIR ENCOURAGEMENT AND CONTRIBUTION OF MATERIAL HAS BEEN INVALUABLE.

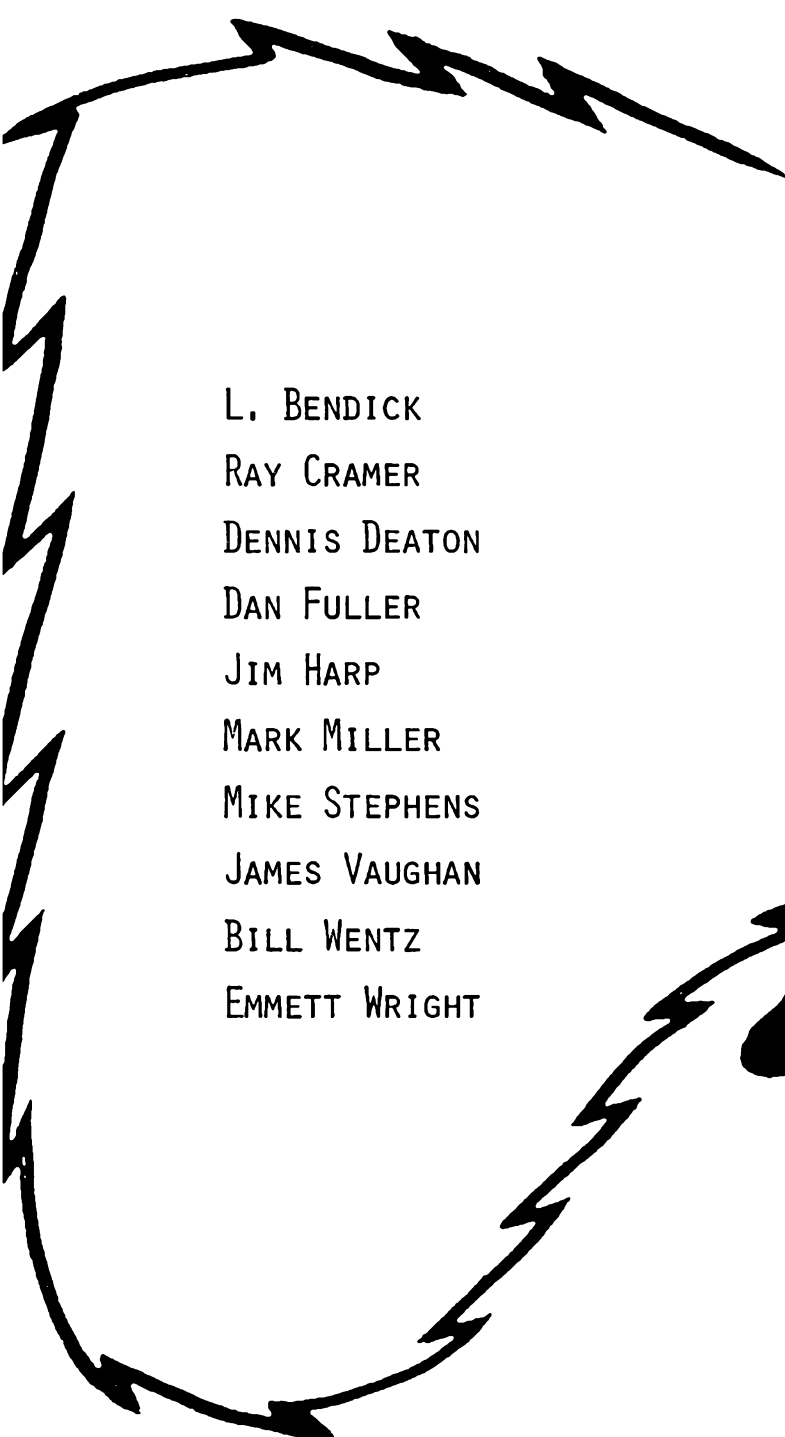

L. BENDICK
RAY CRAMER
DENNIS DEATON
DAN FULLER
JIM HARP
MARK MILLER
MIKE STEPHENS
JAMES VAUGHAN
BILL WENTZ
EMMETT WRIGHT

WANTED

NEW MODIFICATIONS
NEW CONVERSIONS
TECHNICAL TIPS
PROJECT PLANS
ETC. ETC. ETC.



VIC SAYS "THANKS" AND A FREE BOOK TO THE ABOVE PEOPLE.

INTRODUCTION

By now I am sure most of you have heard about at least one of the FM export models available. The 148GTL-DX with its familiar "Roger Beep", followed by a Stalker IX and Colt 510. You will find a report on the DX and Stalker IX in this volume. FM seems to really be catching on and the next volume of SECRET CB will contain additional information on this interesting idea.

We have a new kit available on the uPD2824 sideband chassis (AR144, 146GTL, etc.) It is a "digital processor" and eliminates the necessity of changing the chip to a 2816. It gives you 27.415-28.045 and the NB switch can be used to switch it. Order Secret CB Kit #146. Also available is a new integrated circuit PM Power Modulator kit. It can be used with the stock mike or an electret mike can be used for greater sensitivity. A gain adjustment is included on the small 1 1/4" by 2 3/8" PC board for easy adjustment. Order Secret CB Kit #143.

New product reports have been included on the MICROSCAN PLUS DIGITAL PLL EXPANDER and LAMTECH's new fiberglass whip - don't miss them. They are two exciting products you will want to try out.

A special article on how to "break" a chip has been included for the novice experimenter. While it does not work on the newer ROM type PLL's it works very well on the older PLL's of which many, many are still floating around. It is not uncommon to buy a very versatile radio for \$5 at a garage sale or flea market.

Again, thanks to our many "special friends" who help make this publication the best. I wish to each and all of you the very best.

HAVE A MERRY CHRISTMAS.

Best Regards,

Vic Richter

Vic Richter

TABLE OF CONTENTS

	PAGE #
ACKNOWLEDGEMENTS.....	1
INTRODUCTION.....	2
TABLE OF CONTENTS.....	3
BANDIT GOES FIBERGLASS.....	4
NEW MICROSCAN PLUS SYSTEM.....	5-6
BREAKING THAT CHIP.....	7-11
02A TRUTH TABLE.....	12-13
CDE MARK 26 (uPD861).....	14
CLARIFIER SOLUTION FOR COBRA 132/135XLR.....	15-17
CLARIFIER SOLUTION FOR BROWNING BARON & TRAM D-62.....	15-17
HOW TO MEASURE FREQUENCY ON YOUR SCOPE.....	17
COBRA 146GTL.....	18-19
PM77 POWER MODULATOR KIT.....	19
COBRA 148GTL-DX EXPORT MODEL.....	20-24
COBRA 2000GTL.....	25-28
DIGITAL PROCESSOR KIT FOR uPD2824 CHIP.....	28
GEMTRONICS GTX-2325.....	29
J.C. PENNEY 981-6203 (861 CHIP).....	30
DECIMAL EQUIV. OF # DRILLS FOR PC WORK IN INCHES.....	30
JOHNSON 4140 & OTHERS USING MOTOROLA SC42502P PLL.....	31
KENWOOD TS-530S.....	32
KENWOOD TS-820S.....	33-34
MIDLAND 13-882C.....	35
MIDLAND 79-892.....	36-38
PACE 1000MC-1000BC (NDC40013).....	39-41
WIRE GAUGE CONVERSION CHART.....	41
PACE 166 (23 CHANNEL VERSION).....	42
PACE 8155/8010A/9015A.....	43
PACE 8025 and 166 (40 Channel).....	44
PALOMAR SSB-500 - MCl45106P.....	45
RAIDER 4060 - MSM5807.....	46
ROYCE 1-655.....	47
ROYCE 1-639, PACE 8093 (CC1-3001).....	48
SBE-16CB Console II.....	49
STALKER IX (FM EXPORT ONLY MODEL).....	50-54
TEABERRY MODEL STALKER IX.....	55-57
TRISTAR 747.....	58
AM FREQ. EXP. FOR KRACO KCB4806 & 23 Ch AM 02A UNITS..	59
23 CHANNEL 02A AM MODIFICATION.....	59
AM TUNE-UPS: AUDIOVOX MDU-6000, K40, LAFAYETTE CHB740.	60
AM TUNE-UPS: PACE CB166 (40 ch.), Realistic TRC-411..	60
AM TUNE-UPS: TEABERRY TITAN "T", TRUETONE MIC4726A-67	61
MODULATION ADJ. for: COBRA 85, GEMTRONICS GTX-23, MIDLAND	61
13-881, SBE CONSOLE V, SBE TRINIDAD, TEABERRY BIG T....	61
MAKE YOUR "DWIGHT D" SLIDE.....	62
TENNA POWER #10901, FEILDMASTER TR-40, MIDLAND 102M...	63
CRYSTAL CONVERSION.....	64
POWER MODIFICATION FOR AM UNITS.....	65
PRO-22 POCKET SCAN AM/FM.....	66-69
"OOPS, WE GOOFED": VOL. 12, PAGE 7 - MOTOROLA CM555..	69
VOL. 13, PAGE 63 - ROBYN T240D....	69
VOL. 14, PAGE 12 - CRAIG L321.....	69
POINTER'S ON WHAT TO DO BEFORE CONV./MOD./TUNE UPS....	70
HOW TO CONVERT A SALVAGED METER TO A VOLT METER.....	71
STATE & INTERNATIONAL LOCATION DESIGNATORS.....	72
SECRET CB INDEX FOR VOLUMES 1 THRU 14.....	73-79
ORDER FORM FOR "SECRETS OF SATELLITE TV" VOLUME 2.....	80

!BANDIT GOES FIBERGLASS!

The guys at LAMTECH have done it again! The world's only true 50 ohm fiberglass stick - aptly branded the "BASTARD STICK" (maybe thats what the competitors call it!). Since it is a true 50 ohm antenna you don't have to worry about coax length, it simply doesn't matter. The length is dictated only by your needs. This is attributed to its special coil design. It is available in clear, white, black, red, or blue; and in an incredible 1' (no misprint), 2', 3', 4', or 5' length. Their 1' is the only 1' antenna that will tune all 40 channels. These are three-quarter wavelength designs.

Another UNIQUE feature is the EASY tuning method. No caps to pull off, no wire to dig out and cut. Instead, two tuning rings are used similar to their base load antenna. SWR can be adjusted in less than 60 seconds - remember time is money. The tuning rings are approximately 6 inches from the top. Like all the BANDITS, it too has the same guarantee to "OUTPERFORM ANY OTHER FIBERGLASS WHIP ON THE MARKET OR YOUR MONEY BACK". I've replaced my rusted K-40 with a 4' "BASTARD STICK" and you can't have it! But don't worry there's plenty for everyone. Get on the horn and order yours today.



NEW MICROSCAN PLUS SYSTEM

If you are looking for the most versatile PLL controller on the market today THIS IS IT! Technical features like a custom 40 pin microprocessor "BRAIN", plug in custom PROM's for easy interchange to other radios, simple installation procedure - only 8 connections. The unit comes with a very good 24 page installation and operating instruction booklet for complete documentation. Even a schematic is included. Now lets talk a little about all its features. When power is first turned on the MICROSCAN will always go to channel 40. A unique function is the selectable channel or frequency mode. In the channel mode, any channel from 1-40 may be selected using the STEP, SCAN and UP/DOWN buttons. Depressing the frequency mode button will cause 27.065 to be displayed and any frequency from 26.000 to 27.995 in 5KHz increments may be selected using the STEP, SCAN, or UP/DOWN buttons. The SCAN function can also be used in conjunction with the squelch control to scan until it detects either a BUSY or OPEN channel, depending upon your choice. A memory is available to store a particular freq..

A remote-controlled keyboard similar to a pocket calculator includes all the functions described above plus some advanced innovations. A small cable approximately 34 inches long connects it to the microprocessor.

The following is a brief description of the various mode functions:

- M1 to M5: These are the 5 memory storage keys.
- NORM: This programs the radio without any memory storage.
- SCAN: This initiates the scan from the frequency entered.
- STEP: This allows manual step from the frequency entered.
- SPX: This programs the radio to transmit and receive on the same frequency.
- ALT: This allows separate transmit/receive frequencies or channels to be programed (duplex.)

The UP/DN key reverses the SCAN OR STEP direction.

Continued on next page.

NEW MICROSCAN PLUS SYSTEM continued:

INV: When operating in the ALT mode, this key is used to REVERSE the transmit/receive order. For example, if you are transmitting on 27.900 and receiving on 26.800, pressing the INV key will put your transmitter on 26.800 and receiver on 27.900. Thus, two users who each have the MICROSCAN PLUS can insure MAXIMUM communication privacy since a casual listener will only hear one side of the conversation, which could disappear at any time by depressing the INV key.

Another desirable function is MEMORY SCAN which alternately scans the five memory frequencies you have selected.

I installed the MICROSCAN PLUS SYSTEM into a Robyn SB520D base unit and was delighted with its many functions and simple operation. If you want a versatile operating system, don't delay, order one today!

Service from the manufacture is only a phone call away. They are very willing to insure that the installer and/or user are completely satisfied.

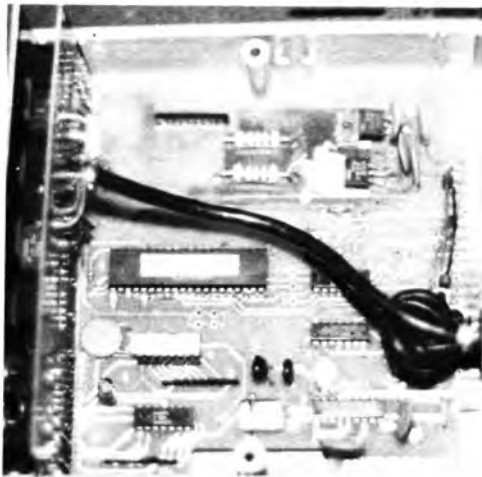

BREAKING THAT CHIP!

By "breaking a chip" we mean reprogramming the address pins of the programmable divider in order to get new frequencies. In almost all synthesizer designs today, the programmable divider is built into the PLL chip. (REF: Vol. 12, page 56 BASIC PLL).

Digital circuits operate in the base 2 or binary system. This gives two possible states - hi, lo; on, off; 1, 0. Each 1 or 0 digit has a value of 2^X , increasing from right to left.

EXAMPLE:

$$69 \text{ (Base 10)} = \begin{matrix} & 64 & 32 & 16 & 8 & 4 & 2 & 1 & \text{Binary Weight} \\ & 1 & 0 & 0 & 0 & 1 & 0 & 1 & \end{matrix} \text{ (Base 2) } (64 + 4 + 1 = 69)$$

OK - simple enough. So don't be afraid to experiment on PLL's. There are a few rules you must not violate however if you want to keep the PLL "alive".

1. The voltage on an address pin will either be hi (near VCC) or low (near ground). NO EXCEPTION. Remember, digital circuits work like a switch, either on or off, no inbetween.

NOTE: There are two ways to do this - the one used will determine how to go about making a "hi" pin "low".

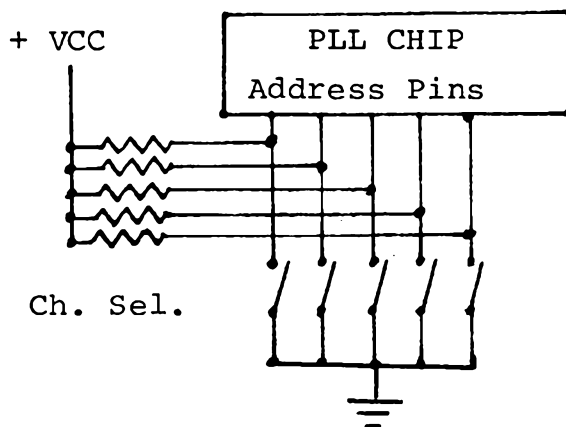

FIG. A1

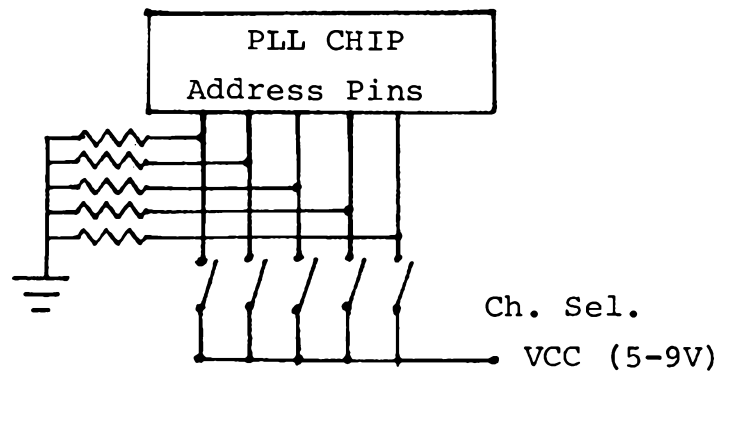

FIG. B1

BREAKING THAT CHIP Continued:

You may run across one that is configured a little different but the same results are obtained. DO NOT attempt a modification on your own if you do not understand the switching arrangement. Like I always say, "Its better to pay a good tech than to make it a wreck"! Remember - when a radio which has been "tampered" with is finally brought into a good tech, his rates will automatically double (if he accepts it at all). This also applies to unit brought in partially disassembled or case missing! So be warned. Enough said - If you are still with me, here is rule number 2.

2. Never apply a voltage greater than VCC to any pin! The 858 chip works on 5V, the 02A on 5V, the 8719 on 8 Volts. The point is, different PLL's operate on varying voltages.

3. If you don't know the PLL pinout (Ref. Vol. 11, page 72-77) (used to determine which pins are address pins) then you are just asking for trouble if you blindly jumper around on the chip. DONT'T DO IT unless you've got a pocket full of money to replace all those zapped chips!

Now lets discuss binary coding using positive logic (positive logic simply means a "high" equals VCC, a low equals ground. Conversely, in neg logic, 0V or ground would be equal to a "hi", and a "low" would be represented by VCC.) The address pins each have a binary weight and the coding is simply obtained from the channel selector switch to give the right input to the divider. Following is an example using the 02A chip:

Continued on next page.



BREAKING THAT CHIP Continued:

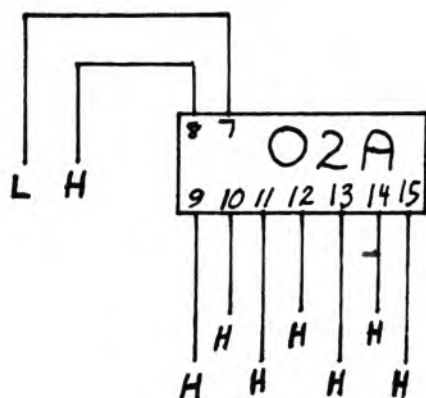

PIN	BINARY WEIGHT
15	1
14	2
13	4
12	8
11	16
10	32
9	64
8	128
7	256

Shown above is the H-L pin status for Ch 1 (26.965). A table showing individual pin status for all possible combinations is called a "TRUTH TABLE". (Ref: Vol. 11, page 5-7, Vol. 14, page 15-17)

This illustrates that any time a "hi" appears on pins 7-15, that binary weight is added.

So the code for ch. 1 is found by adding all the weights of the "H" pins together: $1 + 2 + 4 + 8 + 16 + 32 + 64 + 128 = 255$.

The next channel is ch. 2, 26.975 which has a code of 254. This is obtained by the voltage on pin 15 going low so 1 is no longer added. All other pins are same as ch. 1. (The channel selector accomplished the switching).

NOTE: Different circuits designed may have a different code for ch. 1 even though the same PLL chip is used. The above example is from the most common SSB chassis. This truth table is included in this volume.

A code of 287 = 26.645; a code of 138 = 28.135.

Just because the PLL will program this wide a range doesn't solve all problems. The VCO range must be considered along with RX/TX alignment and widebanding procedures.

Continued on next page.

BREAKING THAT CHIP Continued:

This "pure binary system" of coding is used extensively in programming the PLL's programable divider. However, be advised that it is not the only one used. Sometime a modified version called BCD type is used. (Binary Coded Decimal) Some PLL chips have a chip select pin whose status determines if pure binary or BCD form is used. Also, the newer chips to come along, very popular in AM radios, such as TC9106 & 9109, use a ROM (Read Only Memory) built internal to the chip which responds only to valid codes for channels 1-40. All other codes result in shut-down. Then another method must be used to get extra channels, such as Xtal change or forced signal injection -(Zapper 9000 kit).

If you found this discussion interesting and would like to know more, I suggest you get your hands on a book entitled "The PLL Synthesizer Cookbook" by Harold Kinley, published by TAB Books. It is written so anyone can understand.

The programmable divider code determines the $\div N$ number which controls the frequency of the VCO. The VCO frequency supplies the frequency to the RX mixer and TX mixer. There are many different designs using offset mixers, no mixers, doubling, etc. but ultimately determines frequency of operation.



notes



O2A TRUTH TABLE

Weight Pin #	256 7	128 8	64 9	32 10	16 11	8 12	4 13	2 14	1 15	N
26.645	1	0	0	0	1	1	1	1	1	287
26.655	1	0	0	0	1	1	1	1	0	286
26.665	1	0	0	0	1	1	1	0	1	285
26.675	1	0	0	0	1	1	1	0	0	284
26.685	1	0	0	0	1	1	0	1	1	283
26.695	1	0	0	0	1	1	0	1	0	282
26.705	1	0	0	0	1	1	0	0	1	281
26.715	1	0	0	0	1	1	0	0	0	280
26.725	1	0	0	0	1	0	1	1	1	279
26.735	1	0	0	0	1	0	1	1	0	278
26.745	1	0	0	0	1	0	1	0	1	277
26.755	1	0	0	0	1	0	1	0	0	276
26.765	1	0	0	0	1	0	0	1	1	275
26.775	1	0	0	0	1	0	0	1	0	274
26.785	1	0	0	0	1	0	0	0	1	273
26.795	1	0	0	0	1	0	0	0	0	272
26.805	1	0	0	0	0	1	1	1	1	271
26.815	1	0	0	0	0	1	1	1	0	270
26.825	1	0	0	0	0	1	1	0	1	269
26.835	1	0	0	0	0	1	1	0	0	268
26.845	1	0	0	0	0	1	0	1	1	267
26.855	1	0	0	0	0	1	0	1	0	266
26.865	1	0	0	0	0	1	0	0	1	265
26.875	1	0	0	0	0	1	0	0	0	264
26.885	1	0	0	0	0	0	1	1	1	263
26.895	1	0	0	0	0	0	1	1	0	262
26.905	1	0	0	0	0	0	1	0	1	261
26.915	1	0	0	0	0	0	1	0	0	260
26.925	1	0	0	0	0	0	0	1	1	259
26.935	1	0	0	0	0	0	0	1	0	258
26.945	1	0	0	0	0	0	0	0	1	257
26.955	1	0	0	0	0	0	0	0	0	256
26.965	0	1	1	1	1	1	1	1	1	255 Ch.1
26.975	0	1	1	1	1	1	1	1	0	254
26.985	0	1	1	1	1	1	1	0	1	253
26.995	0	1	1	1	1	1	1	0	0	252
27.005	0	1	1	1	1	1	0	1	1	251
27.015	0	1	1	1	1	1	0	1	0	250
27.025	0	1	1	1	1	1	0	0	1	249
27.035	0	1	1	1	1	1	0	0	0	248
27.045	0	1	1	1	1	0	1	1	1	247
27.055	0	1	1	1	1	0	1	1	0	246
27.065	0	1	1	1	1	0	1	0	1	245
27.075	0	1	1	1	1	0	1	0	0	244
27.085	0	1	1	1	1	0	0	1	1	243
27.095	0	1	1	1	1	0	0	1	0	242
27.105	0	1	1	1	1	0	0	0	1	241
27.115	0	1	1	1	1	0	0	0	0	240
27.125	0	1	1	1	0	1	1	1	1	239
27.135	0	1	1	1	0	1	1	1	0	238
27.145	0	1	1	1	0	1	1	0	1	237
27.155	0	1	1	1	0	1	1	0	0	236
27.165	0	1	1	1	0	1	0	1	1	235
27.175	0	1	1	1	0	1	0	1	0	234
27.185	0	1	1	1	0	1	0	0	1	233
27.195	0	1	1	1	0	1	0	0	0	232
27.205	0	1	1	1	0	0	1	1	1	231
27.215	0	1	1	1	0	0	1	1	0	230
27.225	0	1	1	1	0	0	1	0	1	229
27.235	0	1	1	1	0	0	1	0	0	228
27.245	0	1	1	1	0	0	0	1	1	227
27.255	0	1	1	1	0	0	0	1	0	226
27.265	0	1	1	1	0	0	0	0	1	225
27.275	0	1	1	1	0	0	0	0	0	224
27.285	0	1	1	0	1	1	1	1	1	223
27.295	0	1	1	0	1	1	1	1	0	222
27.305	0	1	1	0	1	0	1	0	1	221
27.315	0	1	1	0	1	0	1	0	0	220
27.325	0	1	1	0	1	0	0	1	1	219
27.335	0	1	1	0	1	0	0	1	0	218
27.345	0	1	1	0	1	1	0	0	1	217
27.355	0	1	1	0	1	1	0	0	0	216
27.365	0	1	1	0	1	0	1	1	1	215
27.375	0	1	1	0	1	0	1	1	0	214
27.385	0	1	1	0	1	0	1	0	1	213

02A TRUTH TABLE (cont.)

WEIGHT PIN #	256 7	128 8	64 9	32 10	16 11	8 12	4 13	2 14	1 15	N
27.395	0	1	1	0	1	0	1	0	0	212
27.405	0	1	1	0	1	0	0	1	1	211
27.415	0	1	1	0	1	0	0	1	0	210
27.425	0	1	1	0	1	0	0	0	1	209
27.435	0	1	1	0	1	0	0	0	0	208
27.445	0	1	1	0	0	1	1	1	1	207
27.455	0	1	1	0	0	1	1	1	0	206
27.465	0	1	1	0	0	1	1	0	1	205
27.475	0	1	1	0	0	1	1	0	0	204
27.485	0	1	1	0	0	1	0	1	1	203
27.495	0	1	1	0	0	1	0	1	0	202
27.505	0	1	1	0	0	1	0	0	1	201
27.515	0	1	1	0	0	1	0	0	0	200
27.525	0	1	1	0	0	0	1	1	1	199
27.535	0	1	1	0	0	0	1	1	0	198
27.545	0	1	1	0	0	0	1	0	1	197
27.555	0	1	1	0	0	0	1	0	0	196
27.565	0	1	1	0	0	0	0	1	1	195
27.575	0	1	1	0	0	0	0	1	0	194
27.585	0	1	1	0	0	0	0	0	1	193
27.595	0	1	1	0	0	0	0	0	0	192
27.605	0	1	0	1	1	1	1	1	1	191
27.615	0	1	0	1	1	1	1	1	0	190
27.625	0	1	0	1	1	1	1	0	1	189
27.635	0	1	0	1	1	1	1	0	0	188
27.645	0	1	0	1	1	1	0	1	1	187
27.655	0	1	0	1	1	1	0	1	0	186
27.665	0	1	0	1	1	1	0	0	1	185
27.675	0	1	0	1	1	1	0	0	0	184
27.685	0	1	0	1	1	0	1	1	1	183
27.695	0	1	0	1	1	0	1	1	0	182
27.705	0	1	0	1	1	0	1	0	1	181
27.715	0	1	0	1	1	0	1	0	0	180
27.725	0	1	0	1	1	0	0	1	1	179
27.735	0	1	0	1	1	0	0	1	0	178
27.745	0	1	0	1	1	0	0	0	1	177
27.755	0	1	0	1	1	0	0	0	0	176
27.765	0	1	0	1	0	1	1	1	1	175
27.775	0	1	0	1	0	1	1	1	0	174
27.785	0	1	0	1	0	1	1	0	1	173
27.795	0	1	0	1	0	1	1	0	0	172
27.805	0	1	0	1	0	1	0	1	1	171
27.815	0	1	0	1	0	1	0	1	0	170
27.825	0	1	0	1	0	1	0	0	1	169
27.835	0	1	0	1	0	1	0	0	0	168
27.845	0	1	0	1	0	0	1	1	1	167
27.855	0	1	0	1	0	0	1	1	0	166
27.865	0	1	0	1	0	0	1	0	1	165
27.875	0	1	0	1	0	0	1	0	0	164
27.885	0	1	0	1	0	0	0	1	1	163
27.895	0	1	0	1	0	0	0	1	0	162
27.905	0	1	0	1	0	0	0	0	1	161
27.915	0	1	0	1	0	0	0	0	0	160
27.925	0	1	0	0	1	1	1	1	1	159
27.935	0	1	0	0	1	1	1	1	0	158
27.945	0	1	0	0	1	1	1	0	1	157
27.955	0	1	0	0	1	1	1	0	0	156
27.965	0	1	0	0	1	1	0	1	1	155
27.975	0	1	0	0	1	1	0	1	0	154
27.985	0	1	0	0	1	1	0	0	1	153
27.995	0	1	0	0	1	1	0	0	0	152
28.005	0	1	0	0	1	0	1	1	1	151
28.015	0	1	0	0	1	0	1	1	0	150
28.025	0	1	0	0	1	0	1	0	1	149
28.035	0	1	0	0	1	0	1	0	0	148
28.045	0	1	0	0	1	0	0	1	1	147
28.055	0	1	0	0	1	0	0	1	0	146
28.065	0	1	0	0	1	0	0	0	1	145
28.075	0	1	0	0	1	0	0	0	0	144
28.085	0	1	0	0	0	1	1	1	1	143
28.095	0	1	0	0	0	1	1	1	0	142
28.105	0	1	0	0	0	1	1	0	1	141
28.115	0	1	0	0	0	1	1	0	0	140
28.125	0	1	0	0	0	1	0	1	1	139
28.135	0	1	0	0	0	1	0	1	0	138

CDE MARK 26 (uPD861)

Coverage up to 28.045:

1. Isolate pin 14 by cutting PC foil out of the way.
2. Add a 4.7K resistor from pin 14 to ground.
3. Wire a DPDT toggle switch as shown:

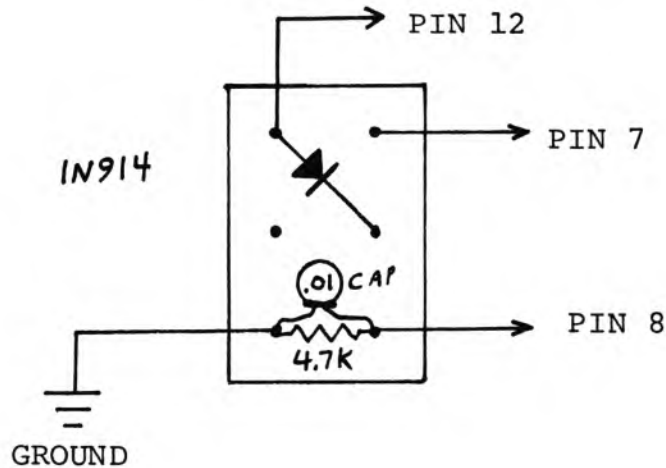

CLARIFIER:

1. Clip D412
2. Remove D58 and install jumper in its place.
3. Clip wire from R465 to BR.
4. Run a wire from R465 to BB (Emitter of Q34).

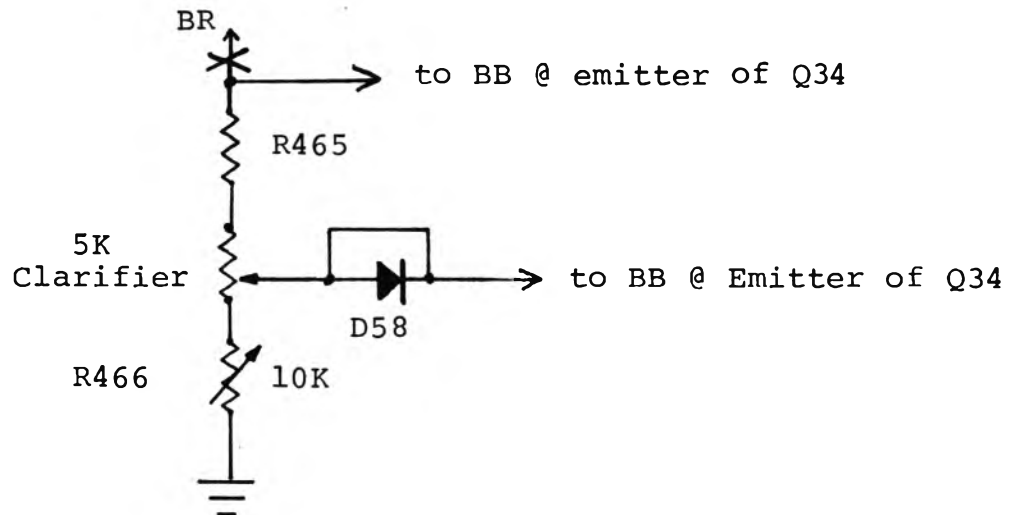

Adjust R466 for desired slide.

COBRA 132/135 XLR CLARIFIER

ALSO

BROWNING BARON & TRAM D-62

STILL HAVING PROBLEMS WITH THE CLARIFIER? IF SO, READ ON FOR THE SOLUTION.

First, let's discuss the problem. This particular clarifier circuit is unique due to its three distinct modes.

1. AM RECEIVE
2. SSB RECEIVE
3. TRANSMIT

The transmit mode is the function we are interested in, but we must learn how the receive mode functions in order to properly convert the clarifier.

If all we ever used was the SSB mode, the conversion would be simple and straight forward, however, the radio is also AM and this is where the problems arise. The output of the clarifier is shifted 2.5KC from receive to transmit. NOTE that the output of the clarifier is the same in all 3 modes while transmitting. Only in the AM receive mode is the output shifted down 2.5KC. The solution, therefore, is to build a circuit that shifts the required 2.5KC after converting the clarifier to slide on transmit.

One more problem encountered is a R/T split which can be corrected by adding a "tight" supply voltage to the clarifier. The following circuit was designed to give the required 2.5KC shift on AM and to regulate the voltages:

First, lets begin by getting all our parts together:

PARTS LIST:

- 1 - Relay SPDT (Radio Shack #275-003)
- 2 - 1N4001 Diode (#276-1101)
- 1 - LM317T Pos. Voltage Reg. (#276-1778)
- 1 - 220 Ω $\frac{1}{2}$ W Resistor (#271-015)
- 1 - 68 Ω $\frac{1}{2}$ W Resistor (#271-010)
- 1 - 1n4735 6.2 V Zener (#276-561)
- 1 - 5 K Pot (#271-1714)
- 2 - 1,000 ufd/16V Capacitor (#272-958)
- 1 - Perfboard (#276-1395)

Continued on next page:

CLARIFIER SOLUTION CONTINUED:

Assemble the parts as shown below. Follow instructions to the letter - radio has double-sided PC board and installing parts on the wrong side will result in PROBLEMS!

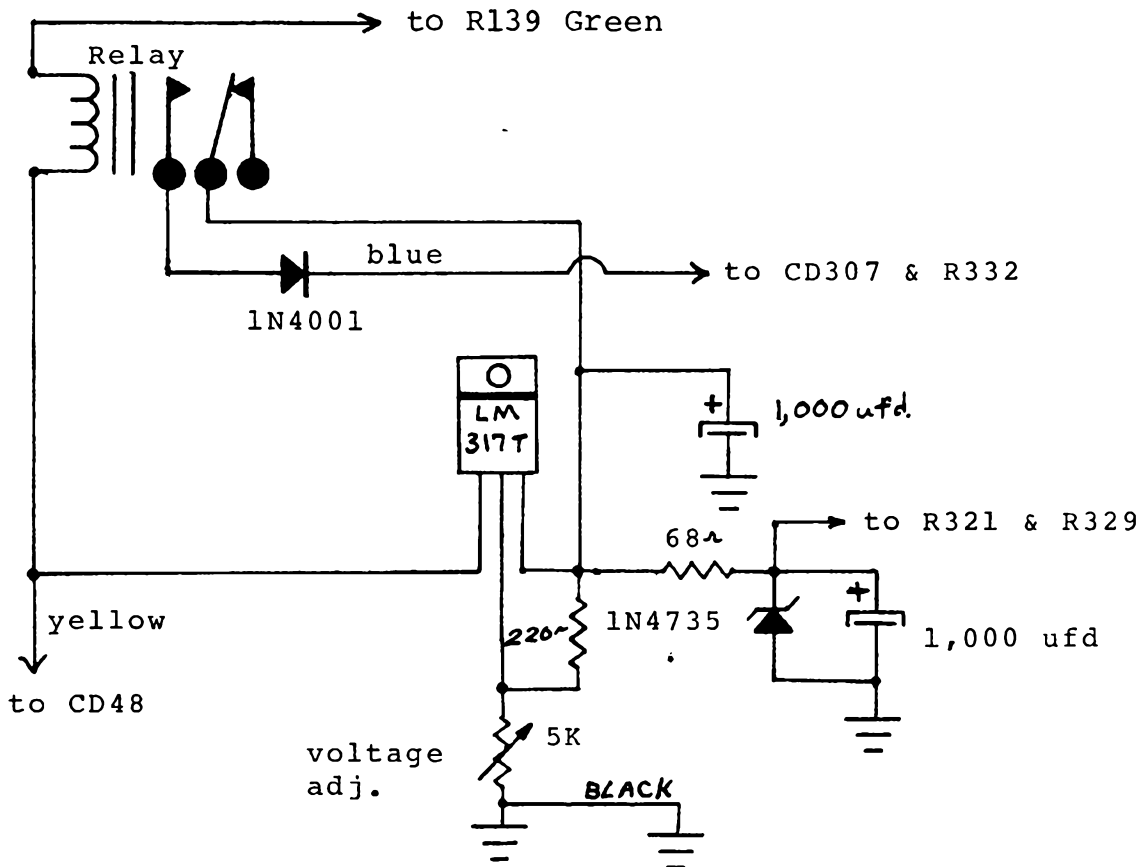

1. Unsolder R321/R329 from the 6 volt source. Solder the two resistors together and solder the WHITE wire from the kit to the resistors.
2. Locate CD307 and R332. Unsolder the ends going to the 7 volt source., Solder the free ends of the diode and resistor together. Connect a 1N4001 diode as follows: cathode (banded end) to D307/R332, anode to the hole where CD307/R332 were connected. At the junction of the NEW diode/Cd307/R332, solder the BLUE wire from the kit. The parts will be on the top side of the board - this is where the double sided board will mess you up!

Continued on next page.

CLARIFIER SOLUTION CONTINUED:

3. Connect YELLOW wire to cathode (banded end) of CD48 (located by relay) to pick up 13.8 V.
4. Connect the GREEN wire from the kit to the end of R139 not connected to the transistor. This provides ground on transmit to switch the relay.
5. Solder a BLACK wire to ground on the kit and solder other end to radio ground.

ADJUSTMENT:

Measure voltage at the BLUE wire in receive mode. Key the mike and adjust the VOLTAGE ADJUST for this same voltage. If no accurate voltmeter is available, hook up your frequency counter to the VCO and adjust the VOLTAGE ADJUST for the same frequency RX and TX.

NOTE: If USB and LSB do not come on center together check the 7.8025 crystal frequency. I have found the adjustment CRITICAL.

HOW TO MEASURE FREQUENCY ON YOUR SCOPE

The period of a waveform is the time that it takes for 1 cycle to occur. It is inversely proportional to the frequency $f=1/P$. Inject the signal to be measured into the vertical input. Adjust the TIME/CM control to display several cycles. The graticule on our scope is 10 CM across. The TIME/CM setting must be multiplied by 10. Now we divide to find the frequency in cycles per second.

$$\frac{\text{COUNTED CYCLES}}{\text{TIME/CM} \times 10} = \text{CPS}$$

XAMPLE: We counted 11 cycles with TIME/CM on 1 Ms setting.
 1 Ms = .001 Second 10 Ms = .01 Second

$$\frac{11}{1 \text{ Ms} \times 10} = \frac{11}{10 \text{ Ms}} = \frac{11}{.010} = 1100 \text{ cycles}$$

COBRA 146GTL

INSTALLING HI-FREQS. ON NB SWITCH:

1. Locate and unsolder to remove 2824 PLL chip located behind channel selector switch.
2. Obtain a 22 pin IC SOCKET and solder in place.
3. Obtain a 4" piece of 2 conductor WHITE/GRAY ribbon wire. Strip and tin all four ends.
4. Solder one end of the GRAY wire to pin 9 of the IC socket.
5. Solder one end of the WHITE wire to pin 21 (ground).
6. Solder across pins 20 & 21 to short together.

NOTE: Consult "SECRET CB" volume 11, page 18 for picture details. Turn Radio over for the following work on the front panel PC board:

7. Make cuts at points W, X, Y, and Z.
8. Install jumper V as shown.
9. Solder GRAY wire across both pads as shown.
10. Solder WHITE wire to pad shown.
11. Obtain a 2816 PLL Chip (SCB cat. #119) and insert it into the the socket. Be sure notch is towards D33 and be careful not to ZAP it!

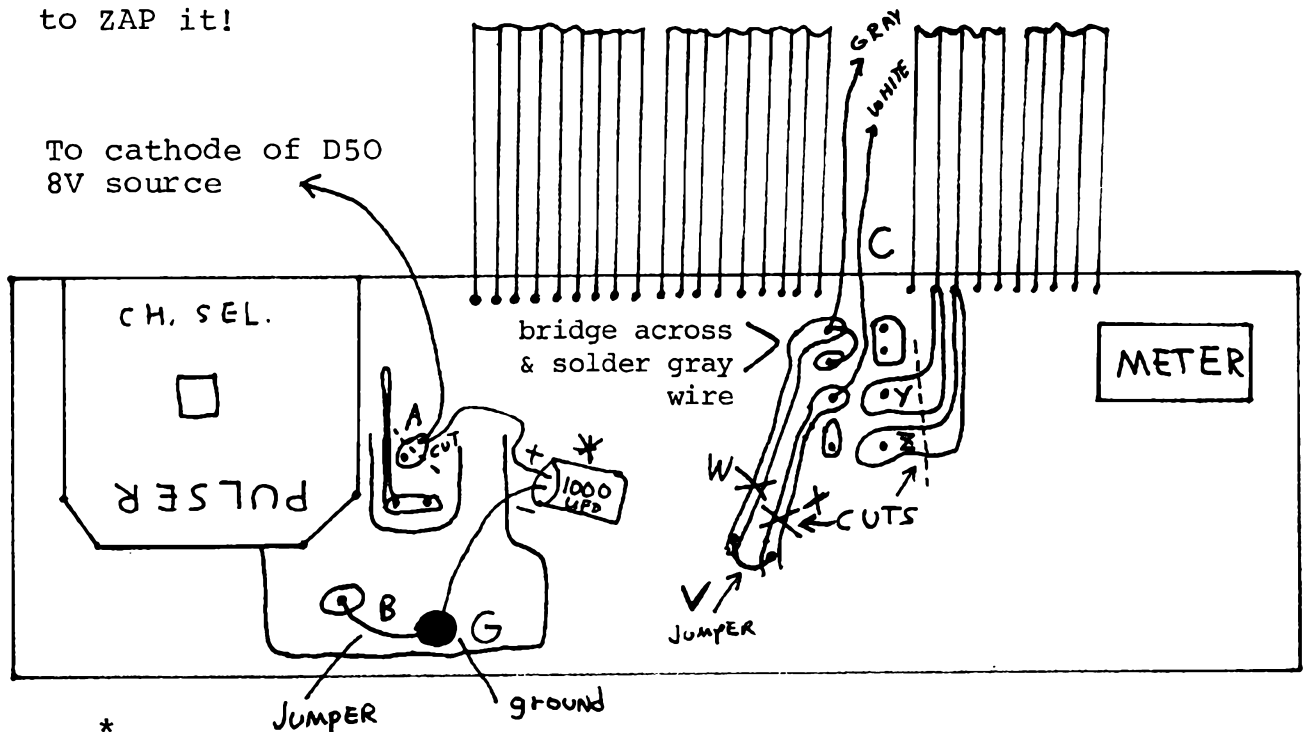

Continued on next page.

COBRA 146GTL Continued:

REMOVE Rubber Pad at point C for access.

* ADD 1,000ufd 16VDC Electrolytic Capacitor for stabilization of 8 V Source.

CLARIFIER:

1. Remove D30 and replace with our Super Diode (SCB Cat. #28).
 2. Make the cut at point labelled A in drawing. Run a wire from A to Cathode of D50.
 3. Install jumper B as shown in drawing.
 4. Solder in a 1,000 ufd/16VDC capacitor as shown in drawing (A to G).
 5. Clip or remove D32.
-

PM77 POWER MODULATOR KIT

Like to have a power mike but don't like the bulky, battery eating mikes currently available? Try our new PM77 Power Modulator Kit. It can be used with any type of microphone or even an electret to really give you signal PUNCH. It also works fantastic in conjunction with the VSB-1 compandor (Secret CB Kit #102) for unbeatable modulation. Order Secret CB Kit #143.



COBRA 148GTL-DX EXPORT MODEL

If you were lucky enough to pick-up one of these overseas, there are still a few things that can be added. The DX is a unique radio - frequency coverage 26.515-27855 on three ranges, a Roger Beep that signals on end of transmission, FM and CW modes. Also, unit sports a dual RIT clarifier, and all the other normal deluxe features, like RF gain, MIC gain, etc..

One of the first things you will want to do is to make the ROGER BEEP switchable. A separate on/off switch could be installed but we choose to use the Ch. 9 switch instead. Here is how:

1. Remove the top and botton covers.
2. Locate the Ch. 9 switch and eyeball the PINK, WHITE, and YELLOW wires.
3. Unsolder the PINK and WHITE wire from the Ch. 9 switch.
4. Unsolder the other end of the PINK wire which goes to the channel selector sub board. Remember which pad it was connected to.
5. Resolder the WHITE wire to where the PINK wire was in (4).
6. Unsolder both ends of the YELLOW wire and remove completely.

NOTE: An alternate version using the Tone hi-lo Switch can be used. To do so, omit steps 2-6 above and follow steps 7 & 8.

7. Locate the Tone Hi-Lo Switch and eyeball the GRAY & ORANGE wire.
8. If you want premanent Hi tone, just unsolder the wires from the switch and PCB and remove completely.

If you want permanent Low tone, solder the GRAY & ORANGE wires together and insulate with heat shrinkable tubing.

We will now proceed to hook up the ROGER BEEP switch using the Ch. 9 or Tone Switch as you decided.

9. Locate the ORANGE wire behind the meter (on component side of board) labeled PEEP. Unsolder this end & clean out hole.
10. Resolder this ORANGE wire to the center terminal on the Ch. 9 or tone switch, depending on which one you decided to use.
11. Solder a new wire into the hole marked PEEP (where the ORANGE wire was removed - step 9.)
12. Solder the other end of the wire in (11) to the top terminal on the switch.

This completes the Roger Beep switch modification.

COBRA 148GTL-DX Continued:

HOW TO DISABLE THE NB/ANL SWITCH:

If you want to add extra channels, you may want to use this switch. So here is how to keep the NB/ANL working all the time.

1. Remove BLUE and PINK wires from the switch and solder together, insulate with heatshrink.
2. Remove the VIOLET and YELLOW wires completely.

HOW TO ADD A VARIABLE POWER POT:

This modification will allow front panel RF power control between 0-11 watts AM using the SWR CAL pot.

1. Remove the GRAY and VIOLET wires completely.
2. Locate the AM power pot (VR13) near the rear of the chassis next to the large electrolytic capacitor C228 (component side.)
3. Turn radio over and locate the three points of VR13 on the foil side.
4. Hook up 2 wires as shown:

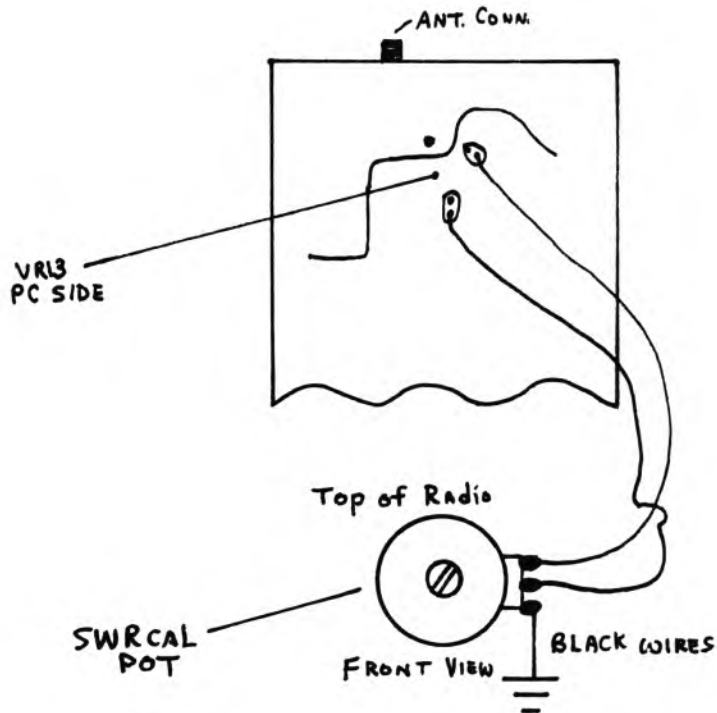

ADJUSTMENT:

Hook up the unit and adjust both pots to obtain maximum power. Back off on VR13 until power just starts to fall and leave at that peak, (approx 10W). This makes the front pot less sensitive. We have found that an outboard amp will sound best with
Continued on next page.

COBRA 148GTL-DX Continued:

ADJUSTMENT continued:

3W driving around 7. Use the built in RF meter as a reference any time you need to go up or down with power.

ADDING FREQUENCIES:

Apply 8V to pin 10 (IC5) for channels 27.795-28.235 on low.

Open pin 11 (IC5) for 25.875-26.315.

→ Open pin 12 (IC5) for 26.335 (ch 12) to 26.635.

Tweak L18 VCO for full frequency coverage.

See diagram below:

- A. Cut trace 12. Solder switch across cut.
- B. Cut trace 11. Solder switch across cut.
- C. Run a wire from center terminal to pin 10.
Run a wire from top terminal to 8 volt source.

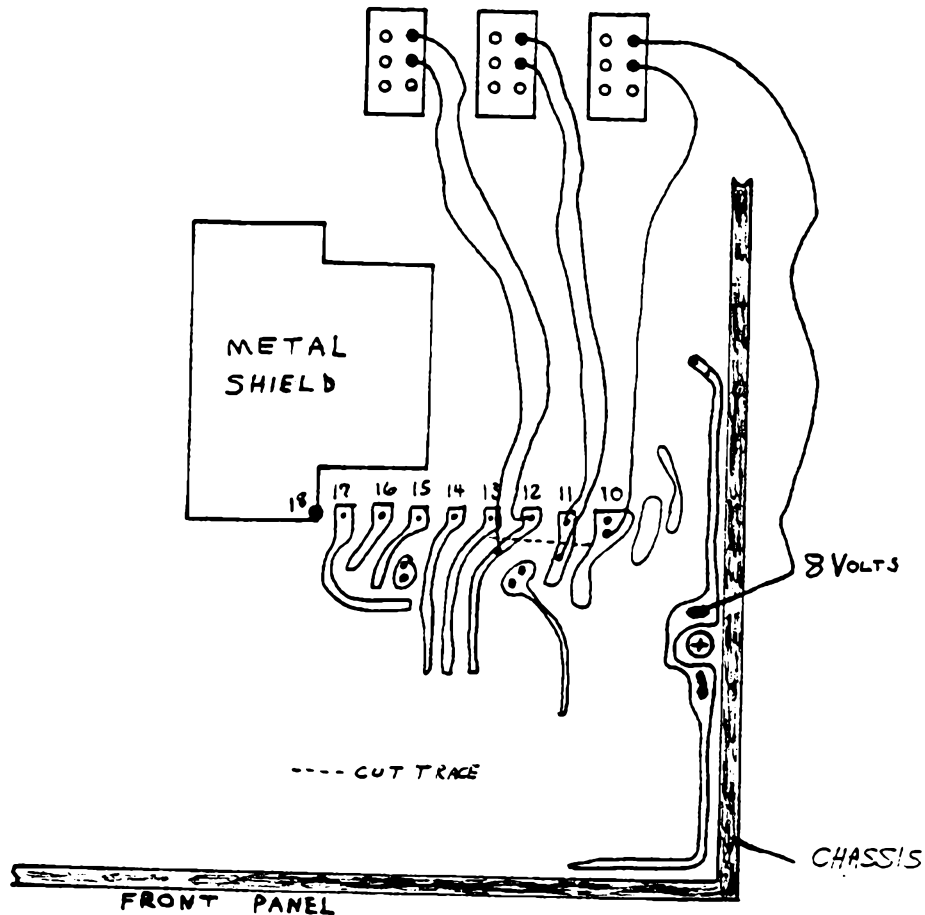

COBRA 148GTL-DX Continued:

ADJUSTMENTS:

- VR1 AM/FM "S" Meter
- VR2 SSB "S" Meter
- VR5 FM Freq. Dev.
- VR7 Carrier Bal.
- VR8 RF Power Meter
- VR12 SSB ALC
- VR13 AM Power
- VR14 AM Mod.



Peak L44 for maximum RF power output.

CLARIFIER INFO:

1. Remove D84, *(D75 ON 390° CHASSIS)* This one works good ↓
 2. Remove BLUE wire from ~~FINE control and PC board.~~ *PC BOARD AND MOVE IT TO OPEN HOLE MARKED (8V COM) NEXT TO WHT WIRE*
 3. Run a new wire from where the BLUE wire was on the fine control to the cathode of D88 (located directly in front of green A473 power transistor on right side of chassis).
 4. For more down slide, pull out R232 and install a wire jumper in its place. This gives about 12KC down.
- * If you like the FINE RIT feature as I do, skip steps 1-3.
The schematic below shows how the above modification works.

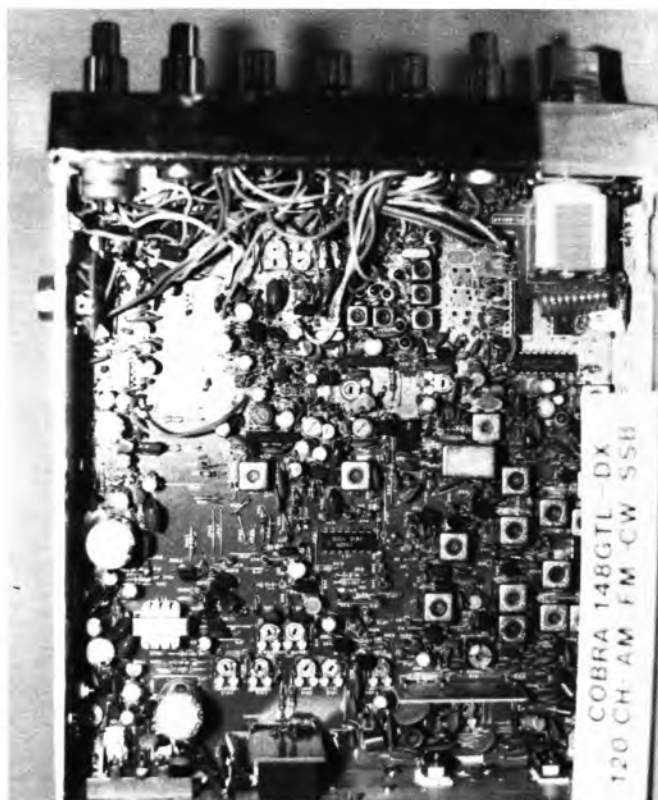
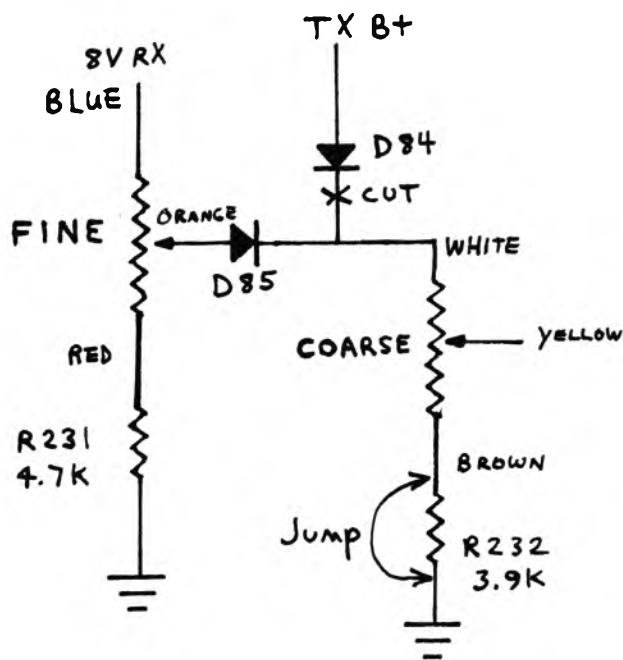

Continued on next page.

COBRA 148GTL-DX Continued:

HOW TO GET "SKIP" CHANNELS:

→ This one is Bullshit

- A. 26.545 (L)
26.995 (M)
27.445 (H)

These are obtained as follows:

Apply 8V to pin 17 for 26.545, 27.445 on ch. 3.

Apply 8 V to pin 16 for 26.995 on ch. 2.

- B. 26.595 (L)
27.045 (M)
27.495 (H)

Apply 8V to pin 16 for 26.595 on ch. 6.

Apply 8 V to pin 17 for 27.045 on ch. 7.

Apply 8V to pin 15 for 27.495 on ch. 4.

- C. 26.645
27.095
27.545

Apply 8V to pin 17 for 26.645 on ch. 11.

Apply 8V to pin 15 for 27.095 on ch. 8.

Apply 8V to pin 17 for 27.545 on ch. 11.

- D. 26.695
27.145
27.595

Apply 8V to pin 15 for 26.695 on ch.12.

Apply 8V to pin 17 for 27.145 on ch. 15.

Apply 8V to pin 16 for 27.595 on ch. 14.

- E. 26.745
27.195
27.645

Apply 8V to pin 17 for 26.745 on ch. 19.

Apply 8V to pin 15 for 27.195 on ch. 16.

Apply 8V to pin 17 for 27.645 on ch. 19.

COBRA 2000GTL

Lots of these still around so here is all the info.

CLARIFIER:

1. Locate and remove BROWN wire from Fine Voice Lock to PC board. No replacement.
2. Locate the RED wire on the other end of the Fine Voice Lock. Unsolder the end that goes to the PC board.
3. Resolder the RED wire to pin 1 of IC4.
4. Locate and remove R44 (gray-red-red). No replacement.
5. Locate and remove R174 (brown-red-orange). Clean out holes and solder in a solid wire jumper in its place.
6. Locate and remove D52. No replacement.
7. Locate and remove D51. Clean out holes and solder in a solid wire jumper in its place.

ADJUSTMENT: Use Channel 20.

Set the CVL and FVL controls to center position for the following Adjustments:

ON AM, adjust L23 for 27.2050 on the built in frequency counter.

ON USB, using a 1,000 hertz tone for modulation, adjust L59 for 27.2060.

ON LSB, using a 1,000 hertz tone for modulation, adjust L22 for 27.2040.

Ours slid down 15kc, up 5kc.

FREQUENCY CONVERSION:

Order "SECRET CB" Catalog Item #27 from your favorite "SECRET CB" Dealer or obtain the following parts:

- 1 - MB8719 PLL Chip
- 1 - 18 pin IC Socket
- 2 - SPST Switches



COBRA 2000GTL Continued:

1. Locate IC1, MB8734 PLL chip and unsolder.

NOTE: CMOS: Make sure power is off, discharge capacitors by turning unit on with no power connected to it.

NOTE: I use a "Soldapullt" Model DS017 desoldering tool for easy removal and hole cleanout.

2. Solder in the 18 pin IC socket in place of IC1.

3. Hook up the 2P6P rotary switch as diagramed in Kit #27 for frequency coverage from 26.815-28.045.

NOTE: If you are not using the kit wire up the two SPST switches as shown:

NOTE: L19, VCO coil, may have to be tweaked to get hi-lo ch.

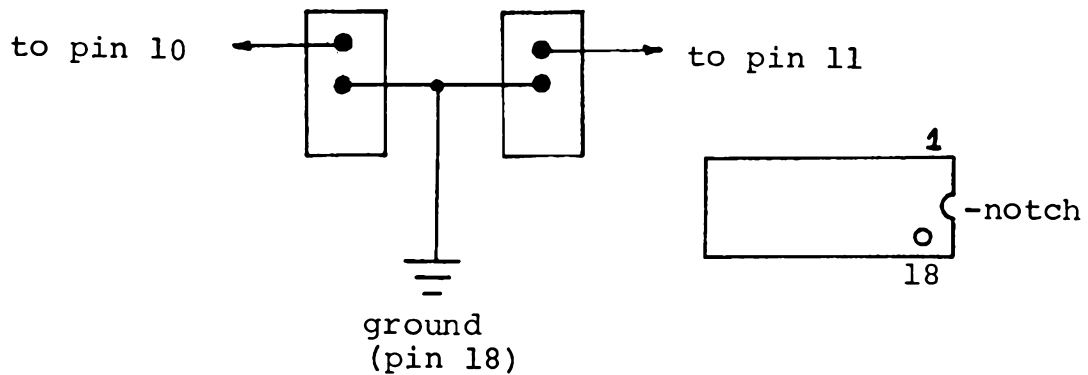

4. Install the new MB8719 PLL chip into the socket. Make sure the notch faces the right hand side as viewed from the front, top (away from the frequency counter unit).

TRANSMIT ALIGNMENT:

Peak L47, L48, L46, L45, L38
L36 is T.V.I. Filter
VR4 Carrier Balance
VR9 Driver Bias Adjust for 25 MA idle current
VR8 Final Bias Adjust for 50 MA idle current
VR11 SSB ALC
VR12 AM Modulation Control
VR10 AM Carrier Power
VR7 Modulation Meter
VR6 RF Power Meter

8719 FREQUENCIES WITH 11.3258

10 LOW

<u>CH</u>	<u>FREQ</u>	<u>CH</u>	<u>FREQ</u>
1	27.605	21	27.855
2	27.615	22	27.865
3	27.625	23	27.895
4	27.645	24	27.875
5	27.655	25	27.885
6	27.665	26	27.905
7	27.675	27	27.915
8	27.695	28	27.925
9	27.705	29	27.935
10	27.715	30	27.945
11	27.725	31	27.955
12	27.745	32	27.965
13	27.755	33	27.975
14	27.765	34	27.985
15	27.775	35	27.995
16	27.795	36	28.005
17	27.805	37	28.015
18	27.815	38	28.025
19	27.825	39	28.035
20	27.845	40	28.045

10+11 LOW

15	27.455	28	27.605
16	27.475	29	27.615
17	27.485	30	27.625
18	27.495	31	27.635
19	27.505	32	27.645
20	27.525	33	27.655
21	27.535	34	27.665
22	27.545	35	27.675
23	27.575	36	27.685
24	27.555	37	27.695
25	27.565	38	27.705
26	27.585	39	27.715
27	27.595	40	27.725

11 LOW

15	26.815	24	26.915
16	26.835	25	26.925
17	26.845	26	26.945
18	26.855	27	26.955
19	26.865	28	26.965
20	26.855	29	26.975
21	26.895	30	26.985
22	26.905	31	26.995
23	26.935	32	27.005

COBRA 2000GTL Continued:

WIDEBANDING:

The following components are located near IC3.

Remove C207 (47pf). No Replacement.

Remove R206 (270K). Replace with 39K.

DIGITAL PROCESSOR FOR THE uPD2824 CHIP

A "digital processor" has been developed resulting in a new conversion kit for the 2824 sideband chassis, such as, the AR144/146GTL. A 3 position toggle switch selects 1-40, 28-72, or 60-104 channel ranges. It is easy to hook up and adjust. Order Secret CB Kit #146 and check one out for yourself.

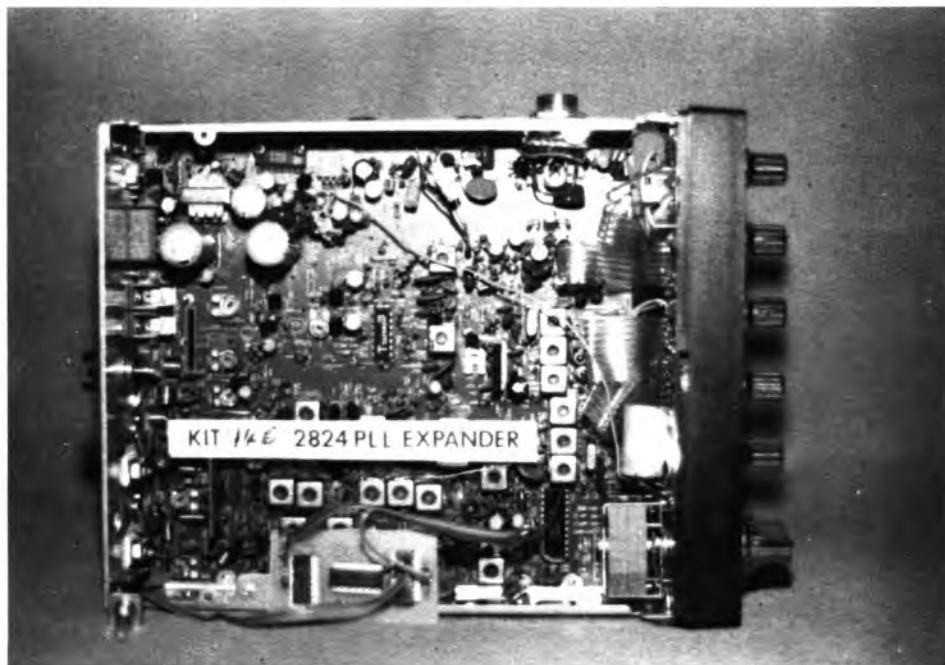

Call or write for our FREE product catalog.

GEMTRONICS GTX-2325

TX: Peak L221, L225, L226
L301 is TVI filter. Adjust for minimum interference on TV Ch. 2.
VC201 Adjust for max. power on AM
VR104 Adjust for Max. power output on SSB (SSB MOD.)
VR205 SSB ALC.
VR103 AM Mod. Gain.
VR206 AMC or clip D214.

Y11 (11.705) can be changed for hi-lo channels. Each new crystal will give 4 channels. Crystal can be installed on toggle switch or rotary switch. To determine the crystal you need for a given frequency, simply subtract 15.3 from channel frequency.

EXAMPLE: We want to get 27.815, 27.825, 27.835, 27.855.
Take 27.855 and subtract 15.3 for a crystal frequency of 12.555.

CLARIFIER:

1. CLIP D123 out of circuit.
2. Disconnect RED wire on one end of Fine Tuning Control.
3. Solder a new wire to where RED wire was on pot.
4. Solder other end of new wire to cathode (banded end) of D128 located on crystal board near Y10 behind SQ. control.
5. Remove D122 and install wire jumper in its place.
6. Adjust L112 for desired slide.

J.C. PENNY 981-6203 (861 CHIP)

For max. mod clip D7 located next to red light emitting diode in front of audio transformer.

For 100% modulation only, clip one end of D7 and insert a 3K resistor in series:

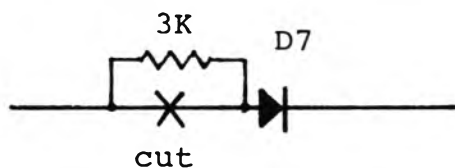

Peak T13 & T14 for maximum RF output.

Decimal Equivalents of Number Drills for PC Work in Inches

80	.0135	64	.0360
79	.0145	63	.0370
78	.0160	62	.0380
77	.0180	61	.0390
76	.0200	60	.0400
75	.0210	59	.0410
74	.0225	58	.0420
73	.0240	57	.0430
72	.0250	56	.0465
71	.0260	55	.0520
70	.0280	54	.0550
69	.0292	53	.0595
68	.0310	52	.0635
67	.0320	51	.0670
66	.0330	50	.0700
65	.0350		

JOHNSON 4140 AND OTHER MODELS
USING MOTOROLA SC42502P PLL CHIP

- A - OPEN PIN 13
- B - GROUND PIN 12
- C - OPEN PIN 13 - PIN 12 TO 13'S CIRCUIT

FREQUENCIES: HI LOW LOW HI LOW LOW

CHANNEL	A	B	C	CHANNEL	A	B	C
1	36	26.165	26.565	21	27.615	26.415	26.815
2	37	26.175	26.575	22	27.625	26.425	26.825
3	38	26.185	26.585	23	27.655	26.455	26.855
4	40	26.205	26.605	24	27.635	26.435	26.835
5	27.415	26.215	26.615	25	27.645	26.445	26.845
6	27.425	26.225	26.625	26	27.665	26.465	26.865
7	27.435	26.235	26.635	27	27.675	26.475	26.875
8	27.455	26.255	26.655	28	27.685	26.485	26.885
9	27.465	26.265	26.665	29	27.695	26.495	26.895
10	27.475	26.275	26.675	30	27.705	26.505	26.905
11	27.485	26.285	26.685	31	27.715	26.515	26.915
12	27.505	26.305	26.705	32	27.725	26.525	26.925
13	27.515	26.315	26.715	33	27.735	26.535	26.935
14	27.525	26.325	26.725	34	27.745	26.545	26.945
15	27.535	26.335	26.735	35	35	26.555	35
16	27.555	26.355	26.755	36	36	26.565	36
17	27.565	26.365	26.765	37	37	26.575	37
18	27.575	26.375	26.775	38	38	26.585	38
19	27.585	26.385	26.785	39	39	26.595	39
20	27.605	26.405	26.805	40	40	26.605	40

KENWOOD TS-530S

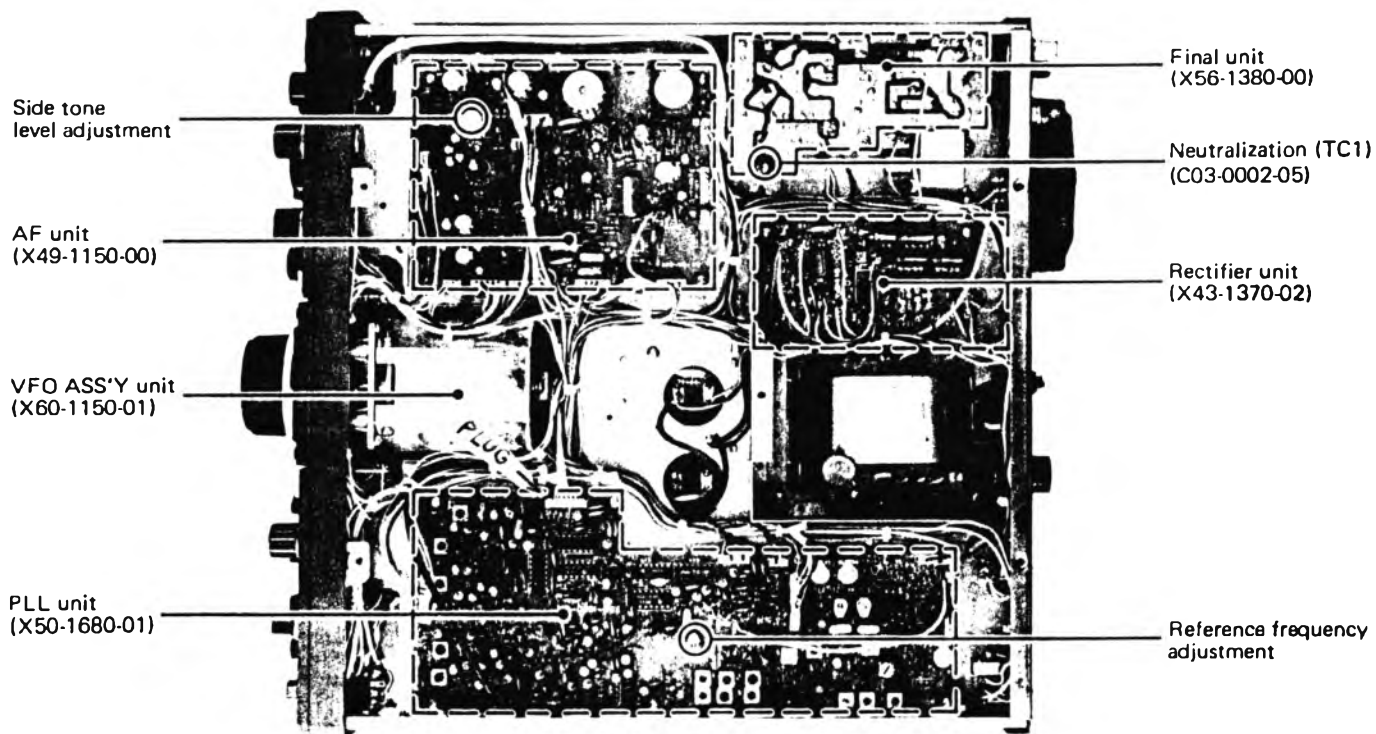

1. Locate the 6-wire plug as shown above.
2. Locate the #2 wire. It is color coded WHITE with purple stripes.
3. Remove this wire from the plug by using a small jewelers screwdriver to pry open the burrs that hold the wire in the plastic plug. Tape up the end of the wire to insulate. DO NOT CUT as this will cause other frequencies to become erratic.

The readout will indicate 28.345 or 29.845 or whatever the VFO is tuned to. Place the mode switch to 29 MHz for one band and push the button for the 28 MHz frequencies.

KENWOOD TS-820S

The TS-820S has a built-in crystal controlled oscillator for fixed frequency operation. To use the fixed frequency oscillator, turn the function switch to the FIX position, turn BAND switch to 28MHz, and FIXED channel select switch to one of the four positions. Now remove the bottom cover. Set unit up on its side with front of unit to your left.

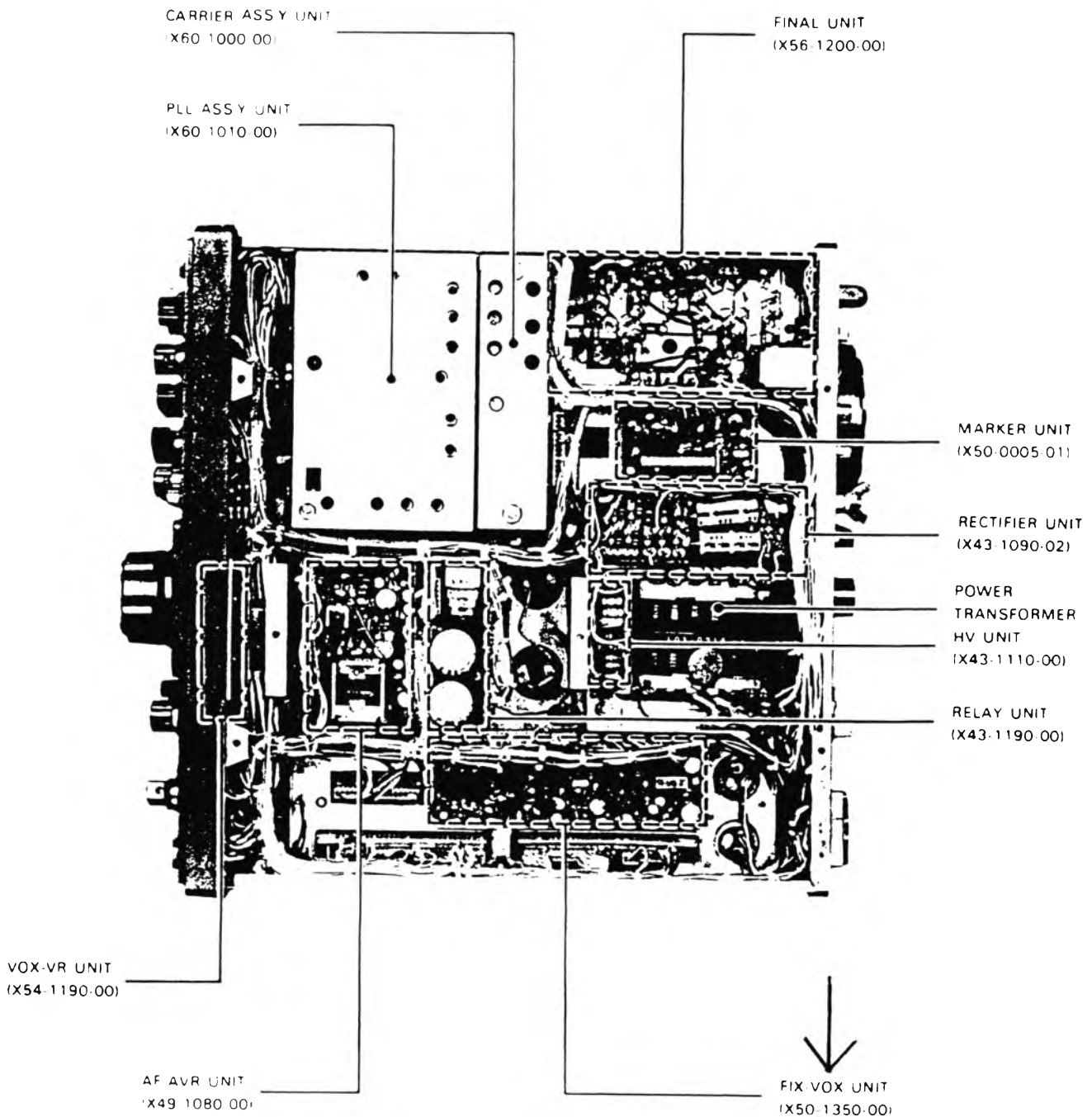

Continued on next page.

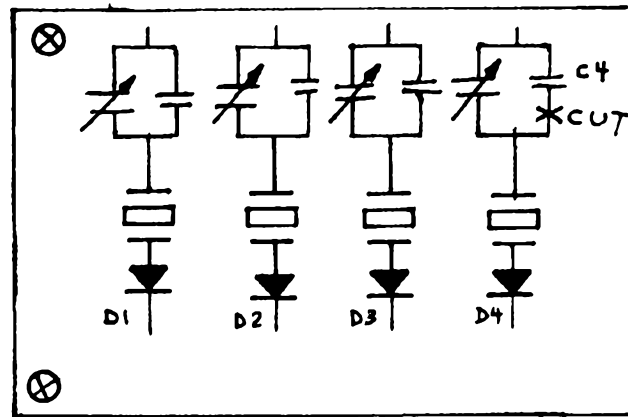

FIX-VOX BOARD

C1, C2, C3, C4 are all 22pf capacitors. If all four positions are to be used, each one has to be cut out as shown on C4.

Now install a crystal for each frequency desired. Specify type HC-25/U.

The crystal frequency is determined by the following formula:

$$5.5\text{MHz} + \text{Band} - \text{desired frequency} = \text{xtal frequency.}$$

EXAMPLE: Lets say we want our fixed frequency to be Ch. 40 (27.405).

$$\begin{array}{r} 5.500 \\ +28.000 \\ \hline =33.500 \\ -27.405 \\ \hline \end{array}$$

6.095 So we will obtain a 6.095 xtal.

Next trim in the desired frequency by adjusting the timmer cap. next to the xtal. Use the digital display to zero it in. This is all there is to it....no other adjustments necessary.

Each position will give you two channels each. Turning the Band switch from 28MHz to 28.5MHz will shift the 27.405 in our example up 50 channels resulting in another fixed frequency at 27.905.

ENJOY!!!!!!

MIDLAND 13-882C

HIGH FREQUENCY CONVERSION:

1. Isolate pin 7 by making 2 cuts.
2. Isolate pins 8, 9, and 10 as shown.
3. Install a 4.7K $\frac{1}{4}$ W resistor as shown.
4. Unsolder PINK wire from EXT. CB SWITCH and tape.
5. Unsolder GRAY and WHITE wire from switch and solder together, tape.
6. Rewire the EXT. CB SWITCH as diagramed.

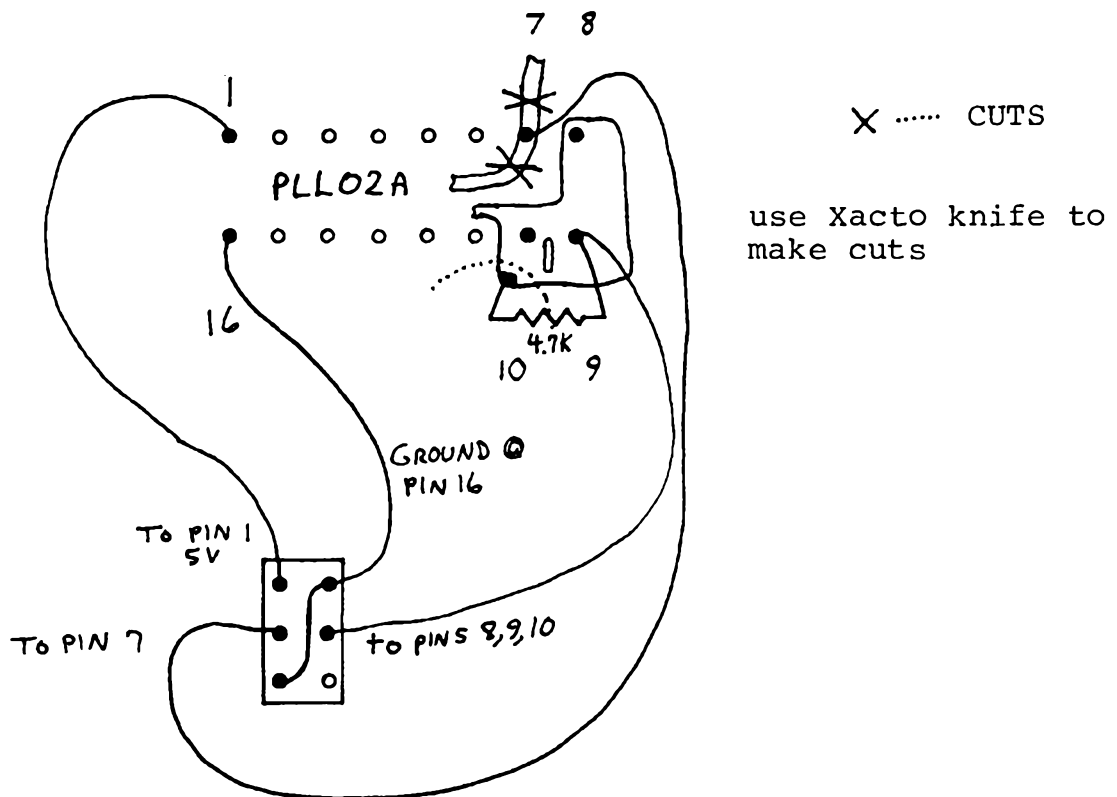

ADJUST VCO T101 if necessary.

THIS GIVES CHANNELS 28-57.

REMOVE Q121 for MAXIMUM MODULATION.

REFER TO "SECRET CB" Volume 13, page 62 for low frequency conversion and tune up information.

MIDLAND 79-892

A common request on this radio is - I want to run a power mike except the clarifier is on the mike, what can I do? Well, here is the answer:

We are going to do 3 things:

1. Change RF gain to clarifier function.
2. Install 4 pin ring connector in place of 6 pin mike jack in unit.
3. Add slide.

Remove the cover and locate the RF gain control. It should look like this:

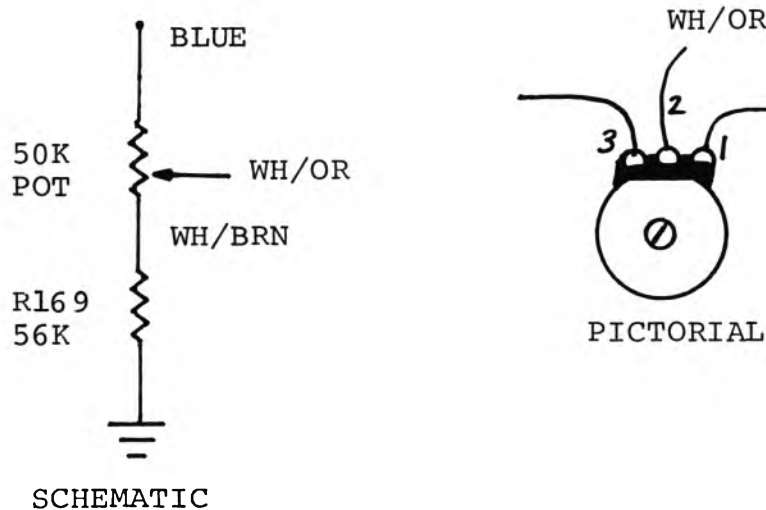

We are going to wire the RF gain so that the receiver is always on maximum sensitivity. This is accomplished by wiring like this:

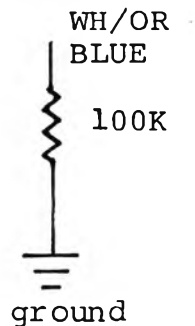

Continued on next page.

MIDLAND 79-892 Continued:

Unsolder the BLUE, WH/OR, and WH/BRN wires from the control. Solder the WH/OR and BLUE wires together. Also solder one end of a 100K resistor to this junction. Solder the other end of the resistor to ground.

Now locate the 6 pin mike jack:

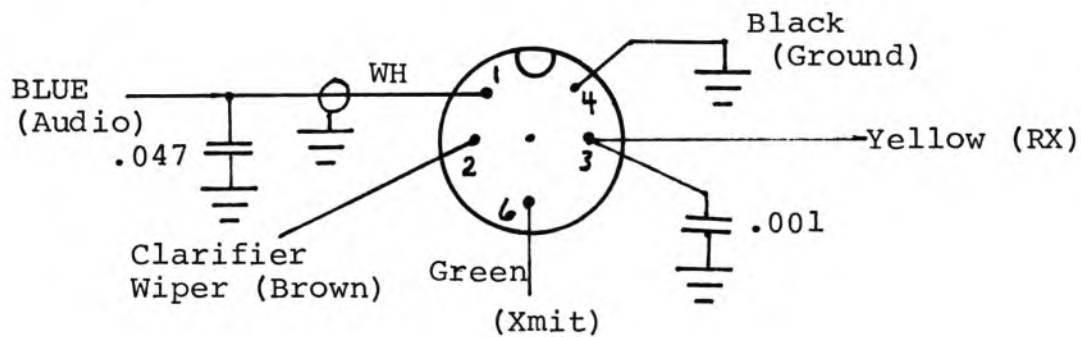

Unsolder all wires and then remove the jack. If you are not sure you will remember, label wires (such as, Black #4) before removing. Install a new 4 pin jack and wire up as shown below:

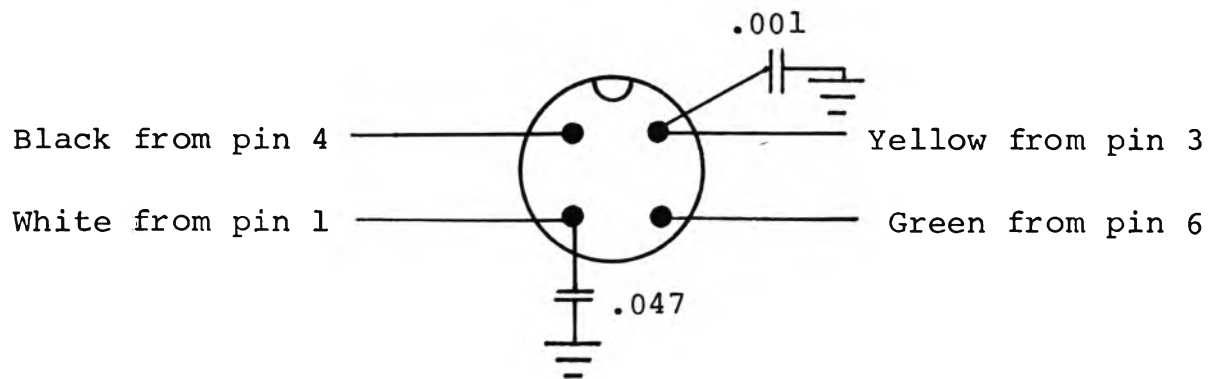

Continued on next page.

MIDLAND 790892 Continued:

The next step is to wire the clarifier function to the original RF Gain Pot, as shown:

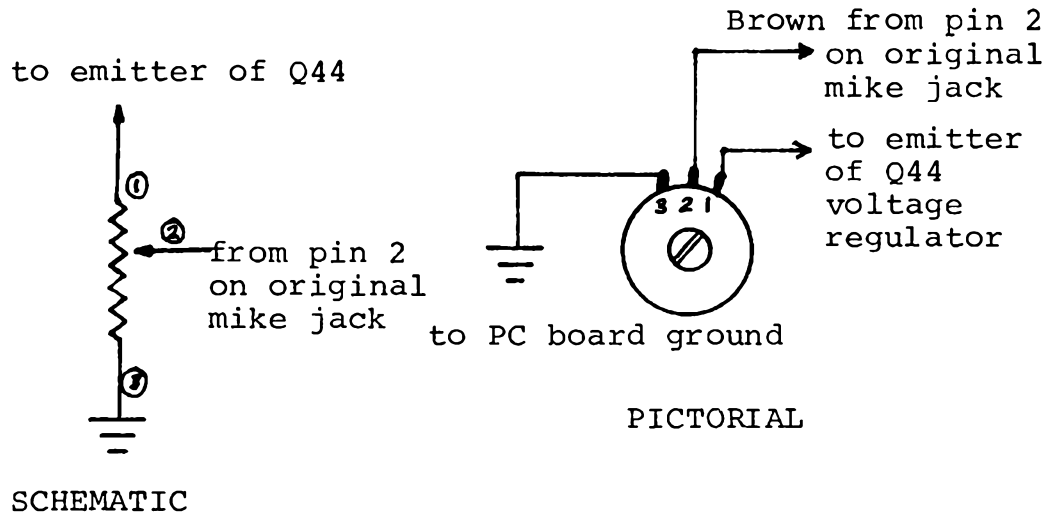

NOTE: If slide works backwards, swap wires on terminals 1 & 3 around.

1. Remove R24
2. Remove D4 and install solid wire jumper.
3. Remove D5.

This completes the modification.

For maximum modulation, remove Q35.

VR4 AM Power

RV11 Mic gain (SSB)

Wire up your favorite power mike to a 4 pin plug and have a modulation ball!!!!

PACE 1000MC - 1000BC (NDC40013)

CLARIFIER:

1. Locate RED and PINK wire next to relay.
2. Unsolder the RED and PINK wire from the PC board, solder together and tape.
3. Adjust R130 for best up range.
4. Adjust R128 for best down range.

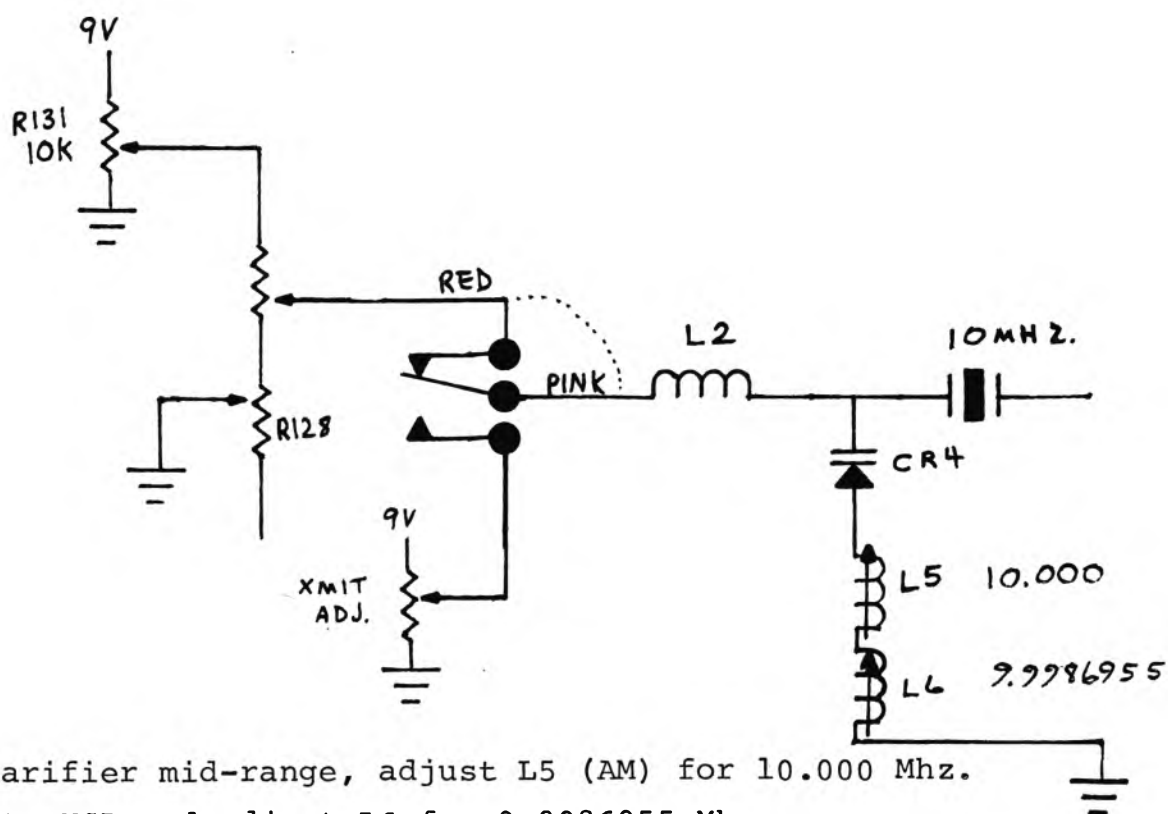

With clarifier mid-range, adjust L5 (AM) for 10.000 Mhz.
Switch to USB and adjust L6 for 9.9986955 Mhz.

FREQUENCY EXPANSION:

1. Remove the YELLOW wire from the channel selector board.
2. Remove the BLUE wire from the channel selector board.

Continued on next page.

PACE 1000MC - 1000BC Continued:

FREQUENCY EXPANSION continued:

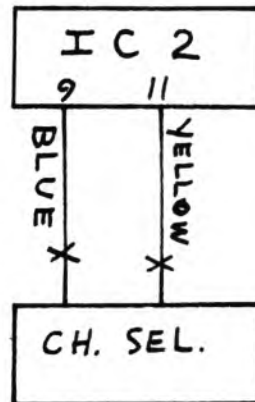

3. Obtain a SPST center on toggle switch. Wire up as diagramed below:

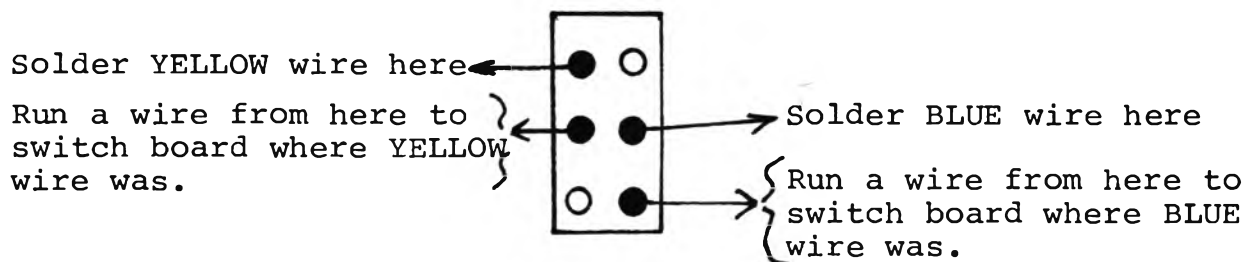

Center position is normal 1-40 channels.

UP gives 27.415-27.475.

DOWN gives 27.485-27.705.

TUNE-UP:

To eliminate the AMC circuit, follow these steps:

1. Locate, unsolder and remove Q20.
2. Locate, unsolder and remove C503.
3. Locate, unsolder and remove R502 (10K).
4. Install a jumper wire from where the - side of C503 was to L501, using the hole left where R502 was removed.
5. Locate, unsolder and remove CR501 (1N60 diode).

Continued on next page.

PAGE 1000MC - 1000BC Continued:

TUNE-UP continued:

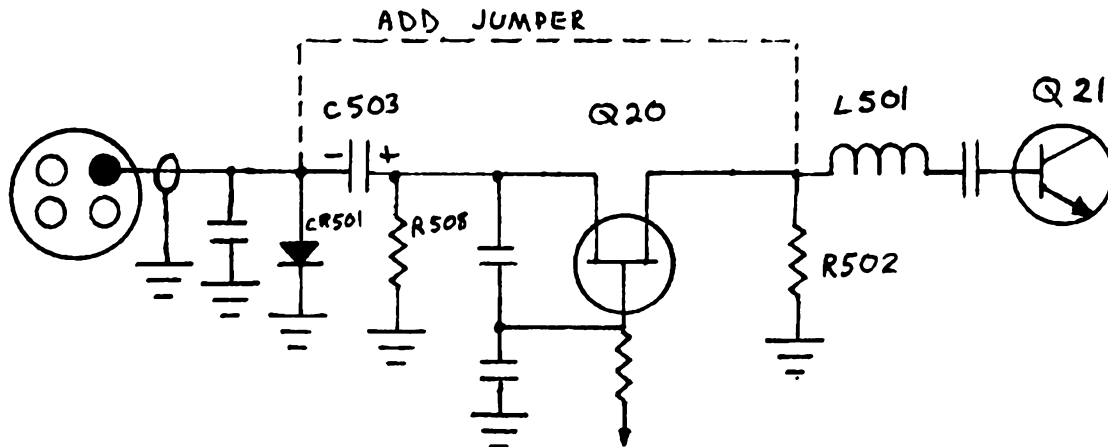

Peak L112, L109, L107 for maximum RF output.

On USB, adjust T501 for maximum RF output.

R521 AM AMC (eliminated this control if you did mod. above).

R134 SSB ALC adjust for maximum.

R103 RF output meter.

R515, C512 carrier null, Ch 19, USB, no mod.

WIRE GAUGE CONVERSION CHART

AWG#	DIA. "		
10	.102	21	.029
12	.081	22	.025
13	.072	23	.023
14	.064	24	.020
15	.057	25	.018
16	.051	26	.016
17	.045	27	.014
18	.040	28	.013
19	.036	29	.011
20	.032	30	.010

PACE 166 (23 CHANNEL VERSION)

MODIFICATION:

- A. Open post of channel switch to pin 4 of U2
- B. Modification A and open pin 5 of U2
- C. Switch wires on pins 3 & 4 of U2 - (pin 5 open)
- D. Disconnect wire from pin 3 of U2 (pin 4 connected/
pin 5 closed)

FREQUENCIES:

Channel	A	B	C	D
1	28	26.535		
2	29	26.545		
3	30	26.555		
4	32	26.575		
5	33	26.605		
6	34	26.615		
7	35	26.635		
8	37	26.645		
9	38	26.655		
10	39	26.665		
11	40	26.685		
12	27.425	26.695		
13	27.435	26.715	26.795	26.955
14	27.445	26.705	26.805	1
15	27.455	26.715	26.815	2
16	27.475	26.735	26.835	3A
17	27.485	26.745	26.845	4
18	27.495	26.755	26.855	5
19	27.505	26.765	26.865	6
20	27.525	26.785	26.885	7A
21	27.535	26.795	26.895	8
22	27.545	26.805	26.905	9
23	27.575	26.835	26.935	11A
24-40	NORMAL			

PACE 8155/ 8010A/ 8015A

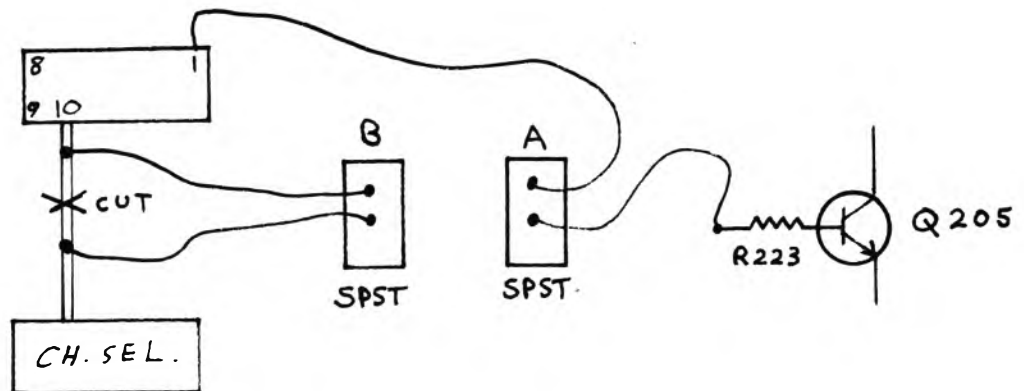

1. Cut trace on pin 10.
2. Wire up the "B" SPST Switch across the cut trace as shown.
3. Wire up the "A" SPST Switch as shown.
4. Replace CR205 with a Super Diode (#28).

With switch A+B off, Frequency from 26.955 - 26.695 are possible.

With switch A on and B off, channels from 41-46 are obtained.

With switch A on and B on, channels from 64-96 are obtained.

Readjust VCO (L202) as necessary to obtain full frequency coverage.

R310 AM Modulation Control.

Peak T403, L404 for maximum. RF power

L401 (Mixer Coil) may have to be tweaked - Easy does it.

On Pace models 8010A/8015A, the A switch connects to R421/Q404.

Varactor is CR405.

VCO COIL is L402.

PACE 8025 AND 166 (40 CH.)

A - OPEN PIN 5 OF U2 ; PIN 4 OF U2 TO GROUND

B - PIN 4 OF U2 TO GROUND ; PIN 5 CLOSED

FREQUENCIES: LOW HI LOW HI

CHANNEL	A	B	CHANNEL	A	B
1	26.645	28	21	26.895	27.535
2	26.655	29	22	26.905	27.545
3	26.665	30	23	26.935	27.575
4	26.685	32	24	26.915	27.555
5	26.695	33	25	26.925	27.565
6	26.705	34	26	26.945	27.585
7	26.715	35	27		
8	26.735	37	28		
9	26.745	38	29		
10	26.755	39	30		
11	26.765	40	31		
12	26.785	27.425	32		
13	26.795	27.435	33		
14	26.805	27.445	34		
15	26.815	27.455	35		
16	26.835	27.475	36		
17	26.845	27.485	37		
18	26.855	27.495	38		
19	26.865	27.505	39		
20	26.885	27.525	40		

PALOMAR SSB-500 MC145106P

1. Cut the trace on pins 10, 11, and 12 of the MC145106P chip.
2. Wire up 2 switches as shown below (we used Brite/Dim and CB/PA switches.)

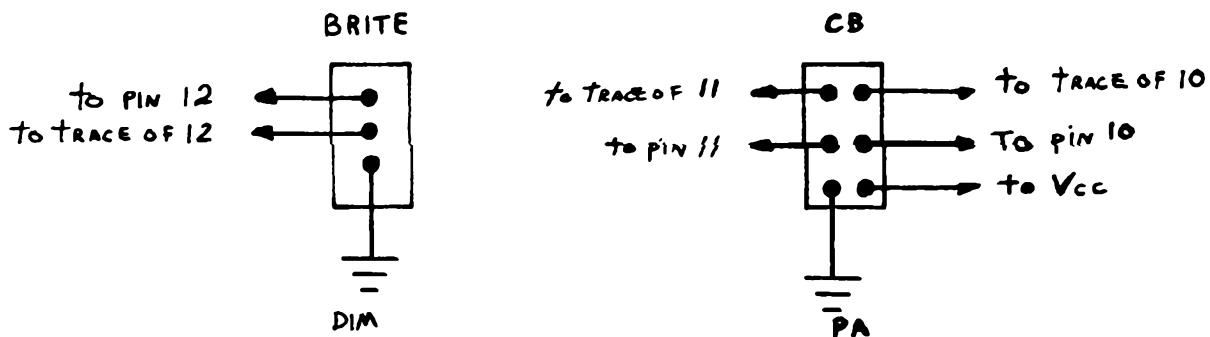

- A. Highs - PA
- B. Lows - DIM
- C. Medium Highs - PA & DIM

FREQUENCIES:

Channel	A	B	C	Channel	A	B	C
1.	27.605			17.	27.805	26.845	27.485
2.	27.615			18.	27.815	26.855	27.495
3.	27.625			19.	27.825	26.865	27.505
4.	27.645			20.	27.845	26.885	27.525
5.	27.655	26.695	27.335	21.	27.855	26.895	27.535
6.	27.665	26.705	27.345	22.	27.865	26.905	27.545
7.	27.675	26.715	27.355	23.	27.895	26.935	27.575
8.	27.695	26.735	27.375	24.	27.875	26.915	27.555
9.	27.705	26.745	27.385	25.	27.885	26.925	27.565
10.	27.715	26.755	27.395	26.	27.905	26.945	27.585
11.	27.725	26.765	27.405	27.	27.915	26.955	27.595
12.	27.745	26.775	27.425	28.	27.925	26.965	27.605
13.	27.755	26.785	27.435	29.	27.935	26.975	27.615
14.	27.765	26.795	27.445	30.	27.945	26.985	27.625
15.	27.775	26.805	27.455	31.	27.955	26.995	27.635
16.	27.795	26.815	27.475	32.	27.965	27.005	27.645
				33-40	ALWAYS NORMAL		

RAIDER 4060 MSM5807

WIRE UP 2 SPST SWITCHES AS SHOWN:

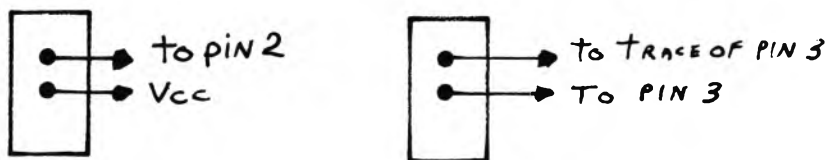

CUT TRACE AT PIN 3

FREQUENCIES:

CHANNEL	A	B	C	CHANNEL	A	B	C
1	27.285	26.325	26.645	21	27.535	26.575	26.895
2	27.295	26.335	26.655	22	27.545	26.585	26.905
3	27.305	26.345	26.665	23	27.575	26.615	26.935
4	27.325	26.365	26.685	24	27.555	26.595	26.915
5	27.335	26.375	26.695	25	27.565	26.605	26.925
6	27.345	26.385	26.705	26	27.585	26.625	26.945
7	27.355	26.395	26.715	27	27.595	26.635	26.955
8	27.375	26.415	26.735	28		26.645	26.645
9	27.385	26.425	26.745	29		26.655	26.655
10	27.395	26.435	26.755	30		26.665	26.665
11	27.405	26.445	26.765	31		26.675	26.675
12	27.425	26.465	26.785	32		26.685	26.685
13	27.435	26.475	26.795	33		26.695	26.695
14	27.445	26.485	26.805	34		26.705	26.705
15	27.455	26.495	26.815	35		26.715	26.715
16	27.475	26.515	26.835	36		26.725	26.725
17	27.485	26.525	26.845	37		26.735	26.735
18	27.495	26.535	26.855	38		26.745	26.745
19	27.505	26.545	26.865	39		26.755	26.755
20	27.525	26.565	26.885	40		26.765	26.765

ROYCE 1-655

Reference: SAMS CB170

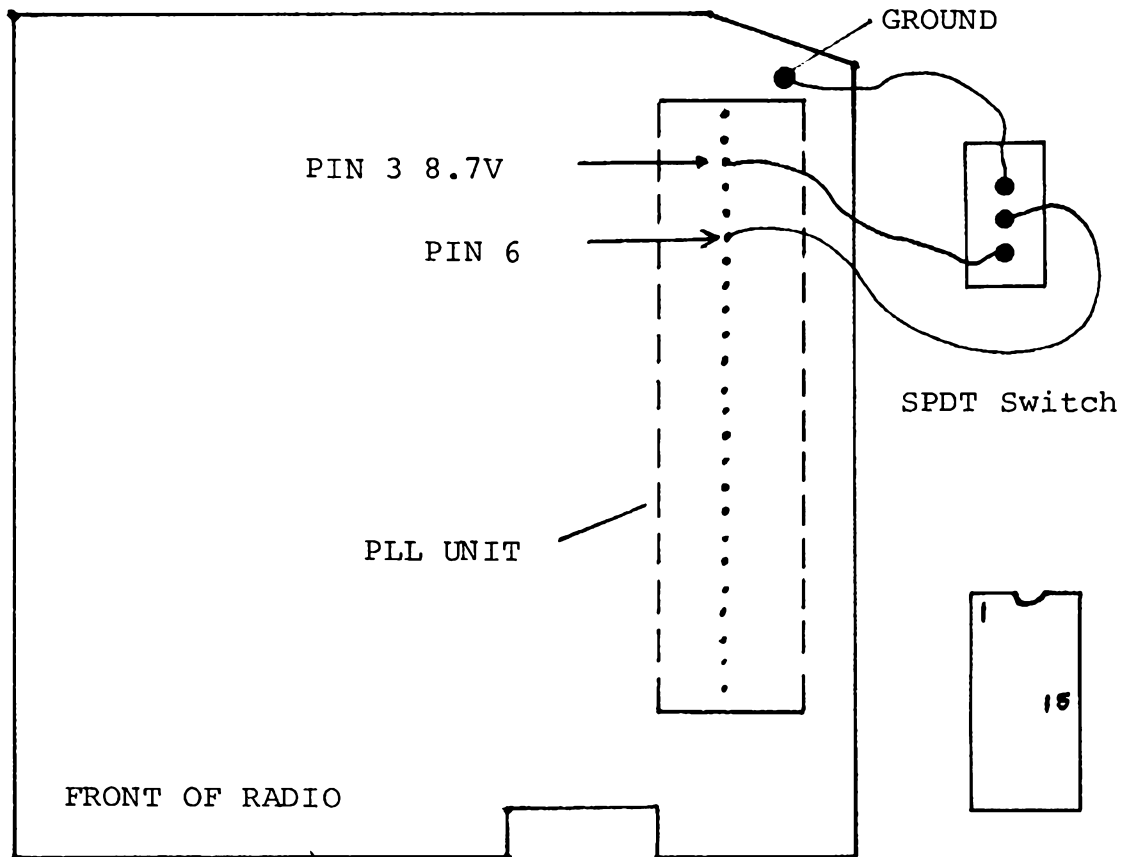

HIGH FREQUENCIES:

Isolate pin 6 and wire a SPDT Switch as above. This yields channels up to 27.575.

LOW FREQUENCIES:

Solder one end of a wire to pin 15 of the PLL Chip (M58473P)
Solder other end to the middle terminal of a SPST Switch.

Run another wire from the other terminal to ground.

This yields channels down to 26.510. Change the varactor diode to a SUPER DIODE (SCB Cat. #28) and retune VCO for full coverage. VCO is the can next to the 36.190 XTAL.

RX: Peak T102, T101

TX: Peak T402, L403, L404

Clip D301 or remove Q301 for MAX. MOD.

ROYCE 1-639, PACE 8093 (CC1-3001)

FREQUENCY EXPANSION: 27.045-27.595

1. Cut trace on pin 11 of PLL chip (CC1-3001).
2. Wire up a SPST switch as shown below.
3. Remove Q23.

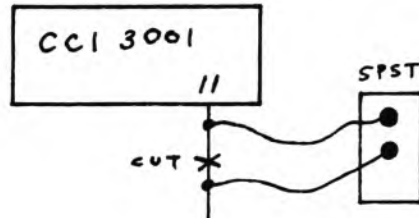

Run wires from switch to both sides of cut to make/break connection.

SLIDER:

1. Locate ORANGE wire on one end of the clarifier pot.
2. Clip the end of the ORANGE wire at the PC board.
3. Resolder to the emitter of Q18.
4. Obtain a 5K trim pot and solder one end and middle terminal of the pot to ground, as shown below.
5. Locate PURPLE wire on other end of pot. Clip this wire at the PC board.
6. Resolder end of PURPLE wire to the ^{UNUSED} ~~middle~~ terminal of the trim pot.
7. Remove C102, C103, C104.
8. Adjust trim pot for desired slide.

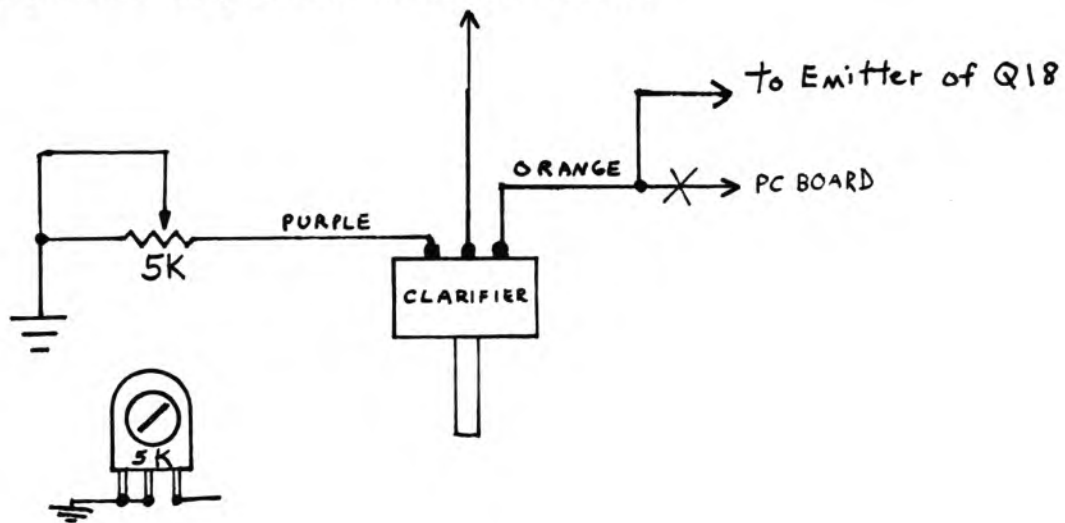

* This unit is similar to SBE LCMS-4. Reference SECRET CB Volume 7, pages 34-37, or SAMS CB285.

SBE-16CB CONSOLE II

Reference: SAMS CB-63

RX: Peak T3, T4, T5, T6, T1, T2, L1.

VR4 AGC

VR5 Squelch Range

VR3 S Meter

TX: VR7 AMC

VR1 ALC

VR6, CV12 Carrier Null

Peak T14, T13, T12, T3, L5, L6, L7, L8.

VR2 RF Meter

TVI CV13

CRYSTALS FOR EXTRA CHANNELS:

11.495	27.760-26.800	12.200	27.465-27.505
11.550	26.815-26.855	12.250	27.515-27.555
11.600	26.865-26.905	12.300	27.565-27.605
11.650	26.915-26.955	12.350	27.615-27.655
12.000	27.265-27.305	12.400	27.665-27.705
12.050	27.315-27.355	12.450	27.715-27.755
12.100	27.365-27.405	12.500	27.765-27.805
12.150	27.415-27.455	12.550	27.815-27.855

STALKER IX (FM EXPORT ONLY MODEL)

This is one whale of a radio! Better ears than the Grant, plenty of talk power, broadband design with good filtering and ACR (adjacent channel rejection). A very strong and versatile unit, one you're sure to enjoy if you can find one. (Looks like all the really neat stuff is for export only!) If you haven't gotten into "FM" yet, be sure to watch for SECRET CB VOLUME 16's FM conversions on particular units. The STALKER IX chassis is similar to 146GTL except for PLL (MB8719 and two full adders), and addition of FM. No schematic available at this time.

TUNE-UP:

VR11 AM Power (Adjust for 7.5W dead key)
VR5 AMC
VR7 ALC (Adjust for maximum)
VR4 Bal. Mod.
VR3 FM Dev.
VR1 S Meter
VR9 Final Bias
VR10 Driver Bias
L17 VCO Coil

Peak L30 for Max. RF.

CLARIFIER MODIFICATION:

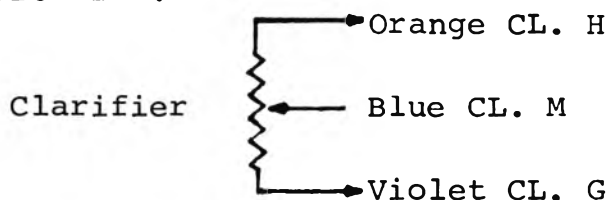

1. Clip D33
2. Unsolder ORANGE wire from PCB point CL. H. Resolder to Cathode of D44.
3. Unsolder and remove R231 (BLUE-GRAY-RED). Clean out holes and install a solid wire jumper in its place (trace VIOLET wire to board to locate resistor)

* This gives 27.34192 to 27.34740.

Continued on next page.

STALKER IX continued:

SLIDER range in excess of 50KC is possible using the SUPER DIODE/SUPER SLIDE combination. A SUPER DIODE alone will give 6KC down and 12KC up. The amount of slide depends on the B+ to the clarifier and the value of R231 which can be altered to your particular specification.

ADDING CHANNELS FOR 26.815 to 28.085 COVERAGE:

In this conversion we will be adding frequencies from 26.815 to 28.085. We will change out the NB/ANL switch to a 3 position switch to eliminate adding any other switch..

1. Unsolder BLUE and YELLOW wires from the NB/ANL switch and remove wires completely.
2. Unsolder PINK wire from switch and PC board and remove completely. NOTE where PINK wire goes on PC board, labeled RB.
3. Unsolder ORANGE wire from switch. Resolder this end to PC board @ RB where PINK wire was.
4. Remove the front panel face plate. (4 screws and all knobs)
5. Remove the 2 screws that hold the NB/ANL switch in place.
6. Remove the switch.
7. Obtain a 3 position slide switch (Secret CB Item #145.)
8. Re-drill the 2 screw holes to accommodate the thicker screws necessary for mounting the new switch.
9. File out the top and bottom of the front panel metal as required for the 3 position switch (the face plate may also have to be cut a little, use an Xacto knife on the bottom inside.)
10. Install the new switch, make sure the screws are not too long or they will prevent the switch from sliding up and down.

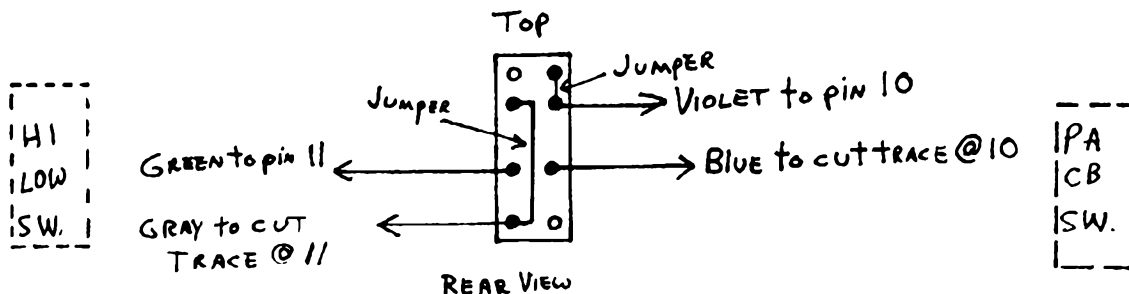

FIG. 1

Continued on next page.

STALKER IX Continued:

11. Install 2 wire jumpers as shown in Fig. 1.
12. Make a cut on the trace of pin 10 of the 8719 chip as shown in Fig. 2.
13. Hook up VIOLET and BLUE wires to the one half of the switch and to pin 10 as shown in Fig. 1 & 2.
14. Make a cut on the trace to pin 11 of the 8719 chip.
15. Hook up GREEN and GRAY wires to the other half of the switch and to pin 11 as shown in Fig. 1 & 2.

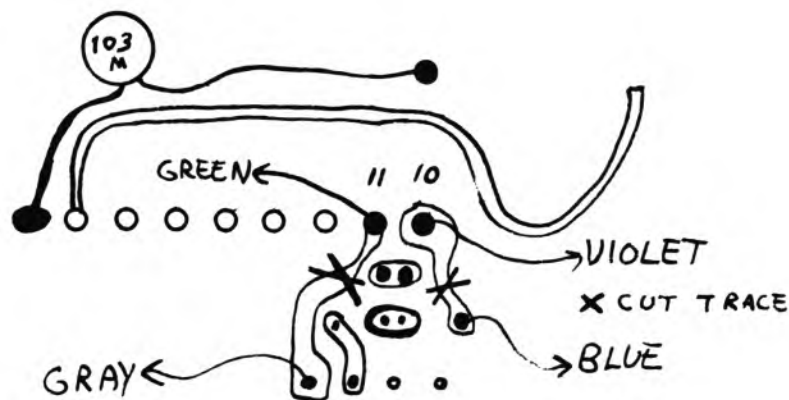

FIG. 2

The 15.4825 crystal can be changed for additional high or low channels.

IF a 15.0325 crystal is installed in its place, ch.1-40 will be on the 41-85 range and lows to 26.515 and highs to 27.635 will result.

For special frequency ranges, use this formula to calculate crystal needed:

EXAMPLE:	Ch. 1	26.96500
	Stock Xtal	<u>-15.48250</u>
		11.4825

Now if we want channel 1 to be 26.515 what crystal do we need?

26.5150	Freq. desired on ch. 1
<u>-11.4825</u>	Ch. 1 VCO
15.0325	Crystal needed

If you want to switch the two crystals use a DPDT switch mounted as close to the socket as possible.

Continued on next page.

STALKER IX Continued:

FREQUENCY CHART:

Following is a frequency listing of the various switch positions:
 The first switch listed is the stock HI-LOW switch. The second
 switch listed is our new switch labeled UP, MID, DOWN.

LO - DOWN Regular 1-40 channels
 LO - MID Also regular 1-40 channels

<u>LO - UP</u>		<u>HI - UP</u>					
1.	28	1.	41 (27. <u>415</u>)	16.	92	31.	108
2.	29	2.	42	17.	93	32.	77
3.	30	3.	43	18.	94	33.	78
4.	32	4.	77	19.	95	34.	79
5.	33	5.	78	20.	97	35.	80
6.	34	6.	79	21.	98	36.	81
7.	35	7.	80	22.	99	37.	82
8.	37	8.	82	23.	102 (28. <u>025</u>)	38.	83
9.	38	9.	83	24.	100	39.	84
10.	39	10.	84	25.	101	40.	85
11.	40	11.	85	26.	103		
12.	42	12.	87	27.	104		
13.	43	13.	88	28.	105		
14.	44	14.	89	29.	106		
15-40	Normal	15.	90	30.	107		

<u>HI - MID</u>							
1.	41	11.	53	21.	66	31.	76
2.	42	12.	55	22.	67	32.	77
3.	43	13.	56	23.	70	33.	78
4.	45	14.	57	24.	68	34.	79
5.	46	15.	58	25.	69	35.	80
6.	47	16.	60	26.	71	36.	81
7.	48	17.	61	27.	72	37.	82
8.	50	18.	62	28.	73	38.	83
9.	51	19.	63	29.	74	39.	84
10.	52	20.	65	30.	75	40.	85

Continued on next page.

STALKER IX Continued:

FREQUENCY CHART Continued:

<u>HI-DOWN</u>					
1.	41 (27.415	16.	1	31.	14
2.	42	17.	2	32.	15
3.	43	18.	3	33.	27.145
4.	26.815	19.	26.995	34.	16
5.	26.825	20.	5	35.	17
6.	26.835	21.	6	36.	18
7.	26.845	22.	7	37.	19
8.	26.865	23.	9	38.	27.195
9.	26.875	24.	27.045	39.	20
10.	26.885	25.	8	40.	21
11.	26.895	26.	10		
12.	26.915	27.	11		
13.	26.925	28.	27.095		
14.	26.935	29.	12		
15.	26.945	30.	13		

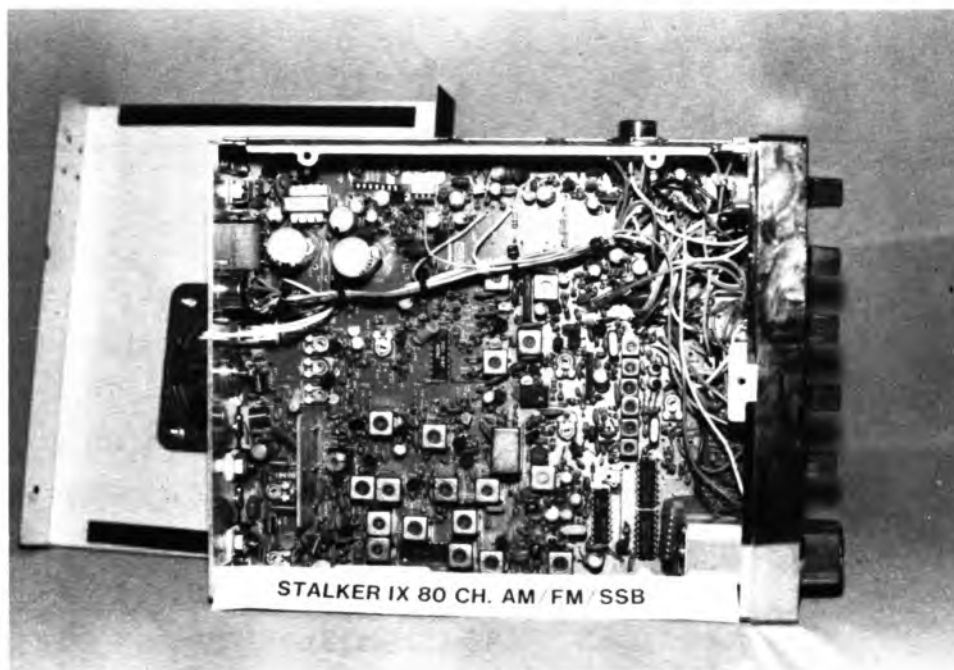

TEABERRY MODEL STALKER IX

FREQUENCY EXPANSION: 26.325 - 28.045

This unit has MB8719 chip/11.1125 Mhz crystal.

1. Obtain 3 SPDT toggle switches and wire up as shown:

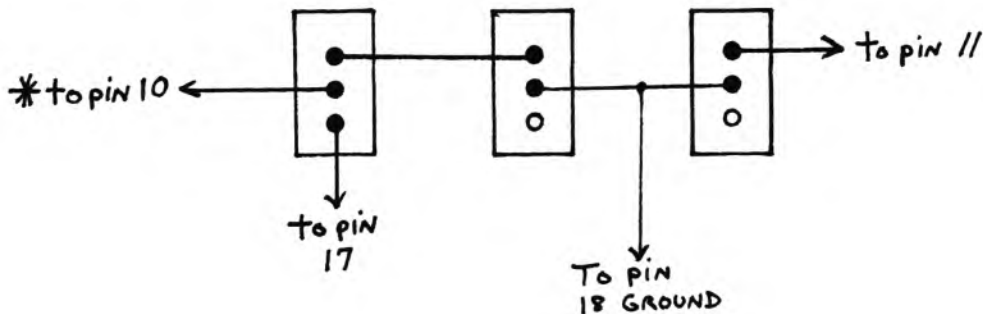

* Cut trace on pin 10 to remove from ground.

Adjust L18 (tripler) and L13 (VCO) - CRITICAL!

WIDEBANDING:

Unsolder, remove and discard C81 (270pf off pin 3 of IC3) - No Replacement.

Change value of R84 from 270K to 39K.

Readjust VR5 Carrier Balance for carrier null on SSB (if necessary).

NOTE: If you don't want this many channels or you have trouble with the alignment, change 11.1125 xtal to 11.3258 and switch pins 10 and 11 for 26.815-28.045.

Before proceeding with the clarifier mod, verify that the above mod is working properly.

Continued on next page.

TEABERRY MODEL STALKER IX Continued:

HOW TO MAKE THE CLARIFIER WORK ON TX:

Here is the circuit:

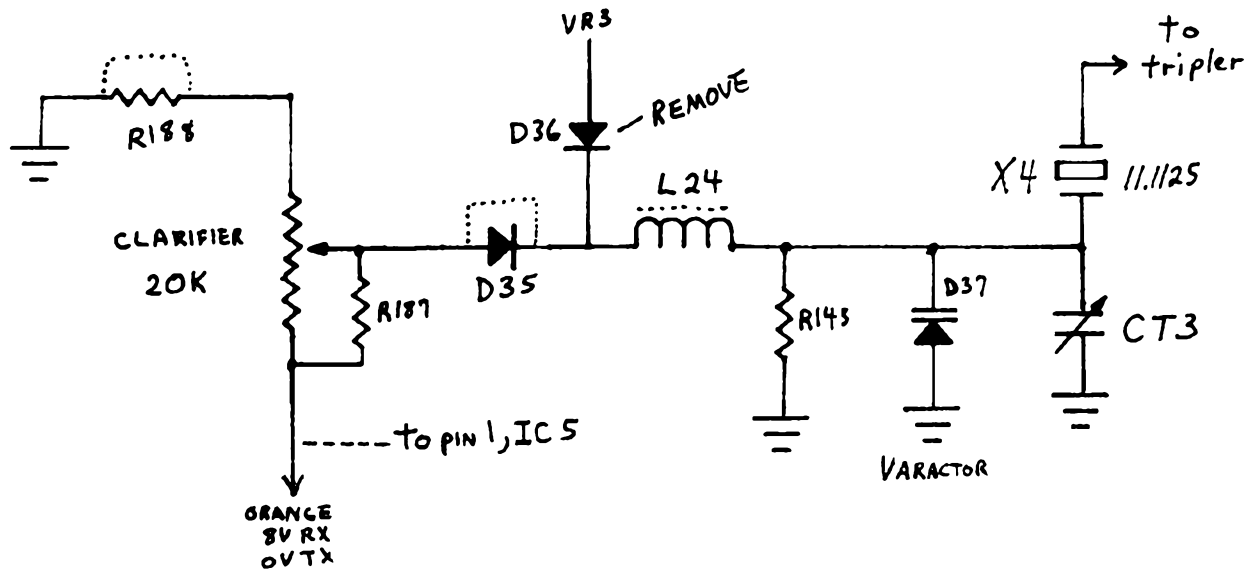

1. Jumper across R188 (Remove R188, clean out holes, install wire jumper, resolder).
2. Remove D36 and clean out holes.
3. Remove D35, clean out holes, install wire jumper, resolder.
4. Remove R187 (22K) and clean out holes.
5. Follow ORANGE wire from end of clarifier over to PCB - unsolder wire at PC board.
6. Resolder end of ORANGE wire to pin 1 of IC5 (MB3756), lengthen wire as necessary.
7. For more slide, remove CT3. Since this is the USB freq. adjustment it will be necessary to return L20 and L19.
 - A. Inject 1KC tone, Ch 20, USB. Read freq. on counter. Lets say as an example it reads 27.208.
 - B. Switch to AM, key mike, no tone. Adjust L20 for 27.207(1KC below USB).
 - C. Switch to LSB, inject 1KC tone through mike, adjust L19 for 27.206 (1KC below AM, 2KC below USB).

* Super Diode/Super Slide in place of D37 gives maximum range over 15KC.

ALIGNMENT:

Continued on next page.

TEABERRY MODEL STALKER IX Continued:

ALIGNMENT:

RX: Adjust L10, L9, L8 for best all around freq. coverage.

VR2 SQ. range

VR1 S meter 100uV/30% = S9

TX: On USB, peak L26, L27, L28, L29, L36.

On AM, adjust L39 for min. interference on TV ch 2 or 3.

VR 8 Driver Bias 35ma

VR 9 Final Bias 45 ma

VR 5 Carrier Null

VR 7 SSB ALC

VR 6 AM power

VR 10 RF Output Meter .

MIKE WIRING:

Pin 1 WHITE (audio)

Pin 2 SHIELD

Pin 3 BLUE (NC,RX)

Pin 4 RED (common)

Pin 5 BLACK (no, TX)

* For MAX. AM modulation, lift collector (middle terminal) of TR32 and add a SPST switch to make/break connection. You will probably want to keep it in circuit on SSB.

AM FREQUENCY EXPANSIONS

KRACO KCB4806

Jump pin 3 of A-006 PLL to pin 2 using a SPST switch. This yields 27.445-27.575 on channels 28-40.

MIDLAND 13-882C

(OR ANY 23 CH. AM O2A UNIT)

LOW FREQUENCIES:

1. Isolate pin 10 from pin 9.
2. Wire a SPDT Switch like this:

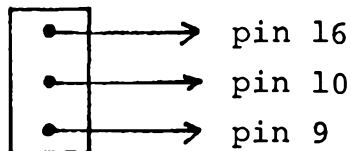

3. Switch UP for normal channels.
Switch DOWN for low channels.

23 CHANNEL O2A AM MODIFICATION

1. Locate and remove 11.806 MHz crystal.
2. Obtain an 11.905 MHz crystal.
3. Obtain a DPDT switch and wire as shown:

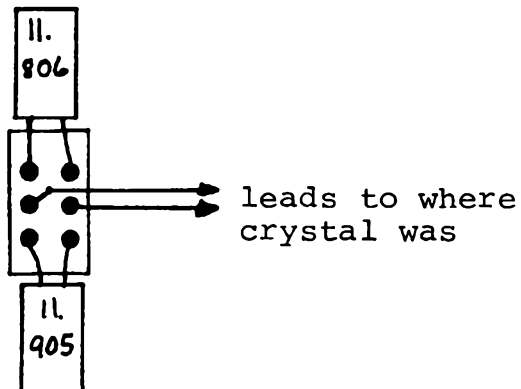

4. Use solid hook-up wire and keep leads as short as possible.
Mount directly over crystal location.
5. This gives channels 26-55 on 1-23.

AM TUNE-UPS

AUDIOVOX MDU-6000:

For max. mod remove Q217

For hi-lo channels, use our Zapper 9000 kit.

Install at C124

K40:

RT401 AMC

Peak L104, L107, L108.

LAFAYETTE CHB740:

Peak L7, L11, L12 for maximum RF output.

RV4 RF power meter

RV2 AMC (or remove C96)

RV3 S Meter

RV1 Squelch Adjustment

PACE CB166 (40 ch):

TX: Peak L8, L9, T13, L10, L14

R156 Squelch Range

R155 S Meter

R207 AMC (or pull out C215)

R413 RF Power Meter

Unit has 2SC1306 final - crank it to maximum

REALISTIC TRC-411 (21-1505) Emergency Mobil (MB8733PLL):

TX: Peak T8, T9, T10, L5, L8

Mod. unsolder R61 and R64 to remove

RX: T1, T2, T3, T4, T5

VR 3 Squelch Range

TUNE UPS CONTINUED:

TEABERRY TITAN "T" (4005) uPD858 PLL:

Order Custom Conversion #11 for 179 channel conversion.

Peak L18, L17, L16, L15, L12, L11

VR2 AMC (pull TR14)

VR1 AGC

VR203 Squelch Range

VR204 S Meter

VR205 RF Power Meter

TRUETONE MIC 4726A-67 (DC4726):

This is a 23 channel crystal rig with battery pack and built in antenna.

TX (power switch to hi) T1, T2, T3, T4, C29, L6, T5

R70 Squelch Range

R51 S Meter

R15 Lo Power Adjustment

R50 RF Power Meter

Modulation Pull C45 first (47ufd) if this won't get you there, then pull D1.

Tune T5 for maximum modulation.

VARIOUS MODULATION ADJUSTMENTS

COBRA 85

Remove Q17 for maximum modulation power.

GEMTRONICS GTX-23

VR481 AMC

MIDLAND 13-881

VR7 AMC

SBE CONSOLE V

Remove C804 (4.7ufd (electrolytic capacitor))

SBE TRINIDAD

R152 AMC

TEABERRY BIG T

VR8 AMC

MAKE YOUR "DWIGHT D" SLIDE

1. Locate, unsolder, and lift the end of R124 (10K) not connected to the base of TR21.
2. Solder one end of a piece of wire to the lifted end of the resistor.
3. Solder the other end to the BLUE wire (9V) on the Delta Tune Control.
4. Remove C132 - 3pf capacitor.

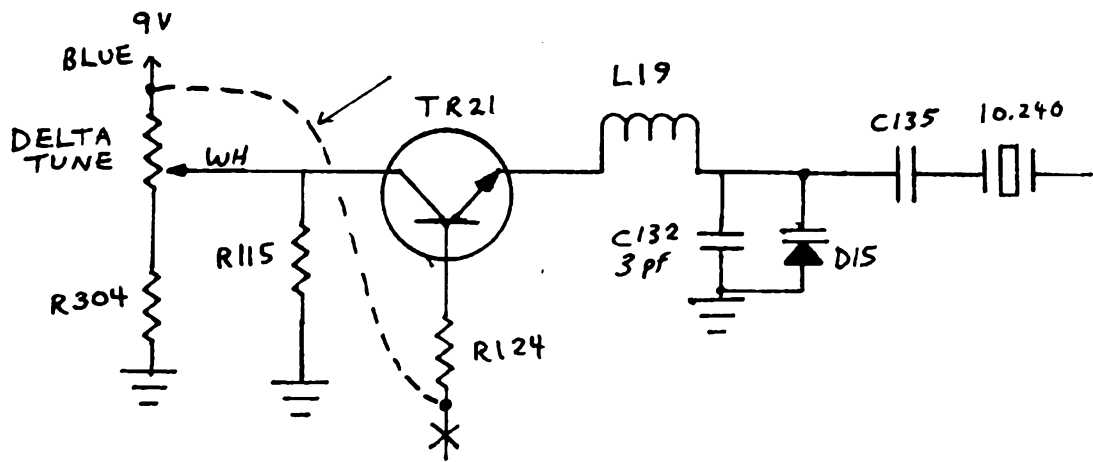

TX ALIGNMENT:

Peak L16, L15, L12, L11 for maximum output on RF Meter using 1KC tone and peak reading watt meter.

VR5 AMC or clip D14.

TENNA POWER #10901, FEILDMASTER TR-40,
AND MIDLAND 102M (77-102)

Steps 1-4 are
for Tenna and
Fieldmaster only

1. Use a DPDT Center Off Switch.
2. Cut loose Pin 2 of MSM 5807 PLL Chip.
3. Bridge with a 4.7K $\frac{1}{4}$ watt resistor.
4. Wire DPDT center off switch as follows:

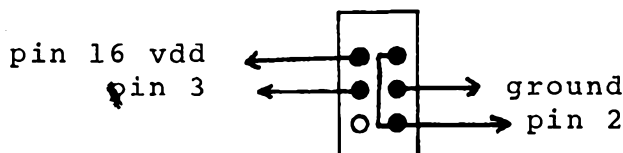

DOWN to 26.645

UP to 27.595

RV-102 RX Meter adjust

RV-202 TX Meter adjust.

RV-101 Squelch range adjust.

The one left is the AMC (no number on PC board).

} MIDLAND 102 m
(77-102)
ONLY

The TENNA POWER #10901 is an odd-ball but a real good performer (broad chassis). Also a good chassis to experiment with, goes about anywhere.

CRYSTAL CONVERSION

1. Remove crystal for channels 1, 2, 3, 4.
2. Obtain and wire a 1 pole, 12 position non-shorting rotary switch as follows: *

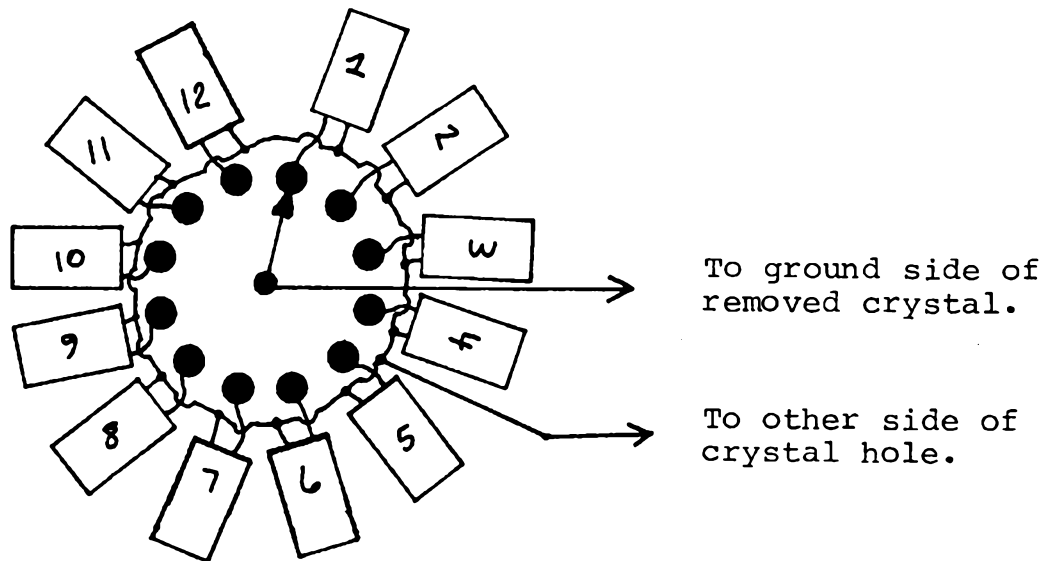

- Solder one leg of each Xtal to a terminal on the switch. Connect other legs together with solid wire for common grd.
3. Solder the crystal from Step 1 in the first position of the switch.
 4. Solder the new crystals in the other 11 positions and wire up as shown above.
 5. Mount switch directly over removed crystal location for shortest lead length.

The frequencies can be high or low, depending on the Xtals you purchase. Consult "SECRET CB" volume 1 or 2 for crystal correlation charts.

*If you don't want this many extra crystals, substitute a 3, 4, or 6 position switch.

POWER MODIFICATION FOR AM UNITS

The following procedure was installed on a Midland 13-857B. This will work on many other 23 or 40 channel sets manufactured by Hy-Gain, Kraco, Lafayette, Boman, and other Cybernet chassis. Most of the AM sets use a 2SC1306 for the final and they just don't tune up much. (you can't get blood out of a turnip!) But with a few parts and a little work, you can make it really talk. HERE'S HOW ITS DONE:

1. Unsolder and remove the 2SC1306 transistor (final).
2. Unsolder and remove the 2SC1760 transistor (driver).
3. Install the 2SC1306 in place of the 2SC1760 so the 2SC1306 becomes the driver. Be sure to install in the correct holes for proper hookup.
4. Install a 2SC1307 in place of the final removed in step 1. Be sure to install in the correct holes - note the extra hole for this transistor for proper lead orientation. Use heatsink compound liberally.
5. Unsolder and remove C148. (120pf) Save for Step 7.
6. Unsolder and remove C149. (220pf) Save for Step 7.
7. Now swap the caps around and resolder on the board (C148 is now 220pf; C149 is now 120pf.)
- Delete.* ~~8. Unsolder and remove C146 (470pf) and replace with a 100pf.~~
9. Retune for maximum power.

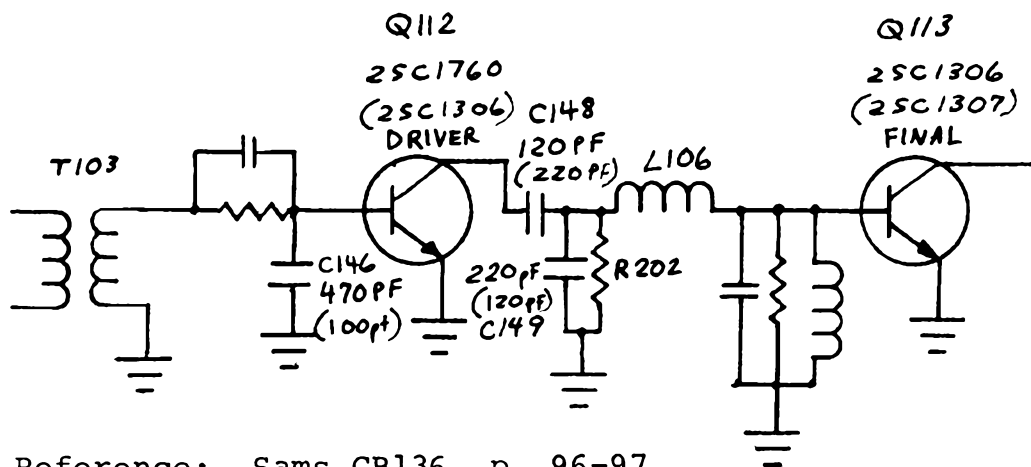

On FM, this will give 12 watts output! This has been thoroughly tested by a friend of SECRET CB.

PRO-22 POCKET SCAN AM/FM

THIS IS A CONVERSION FOR ADDING AN EXTERNAL ANTENNA FOR ADDED RANGE. HERE IS WHAT WE OBTAINED:

RX:	VHF Lo	Fair	10-15 Miles
	VHF Hi	Fair	15-20 Miles
	Aircraft	Fair	10-15 Miles
	UHF Hi-Lo	Fair	15-20 Miles

RX using Rubber Ducky - 5-8 Miles - All Bands.

Antenna must be VERTICAL for best range.

Cost/Quality Ratio: Poor

For outdoors use with Rubber Ducky antenna, range OK for downtown (cop on beat) but price a little high (request the crystals be thrown in).

HERE IS HOW TO DO IT:

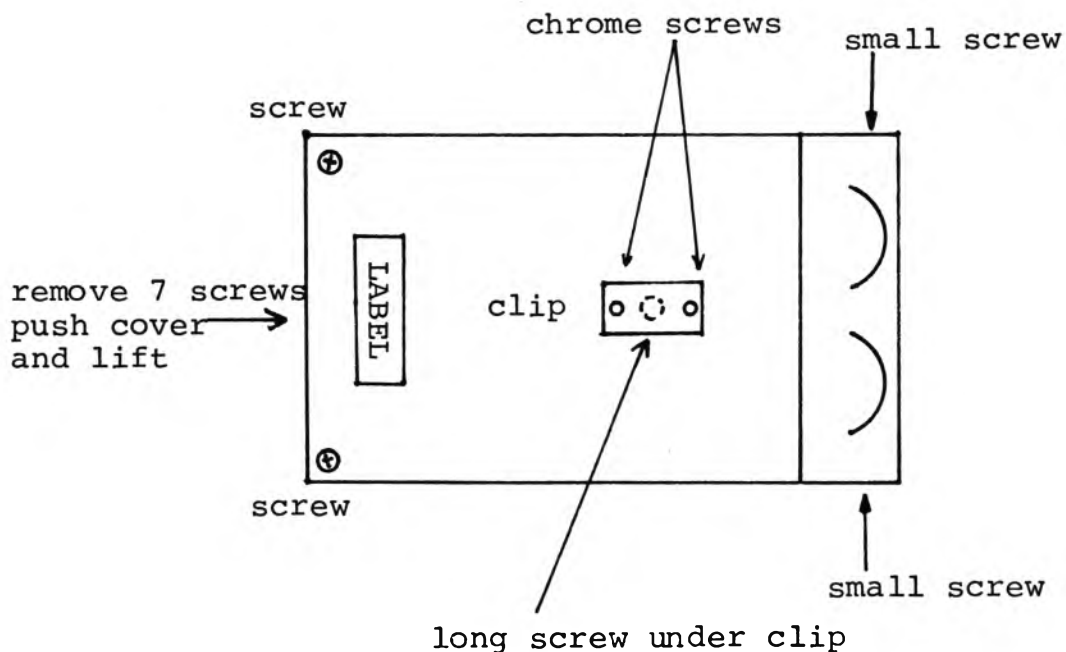

Continued next page:

PRO-22 Pocket Scan AM/FM continued:

- NEXT:
1. Remove locknut on ear phone jack.
 2. Lift PC board and pull gently out.
 3. Check for this:

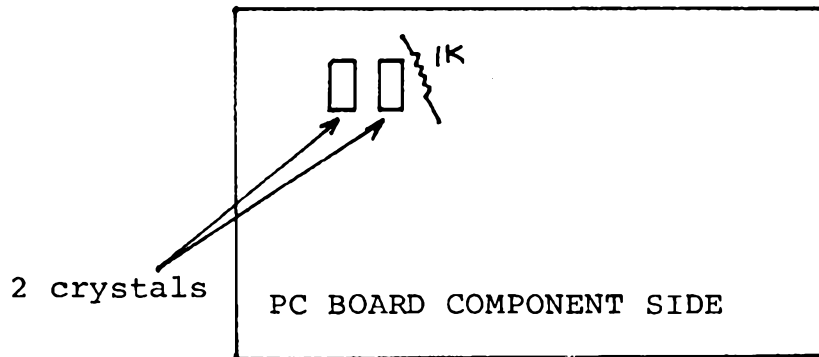

There is a sleeved resistor (1K) running over top of crystal. Cut piece of electrical tape and place over can! Some units have had trouble with it shorting out.

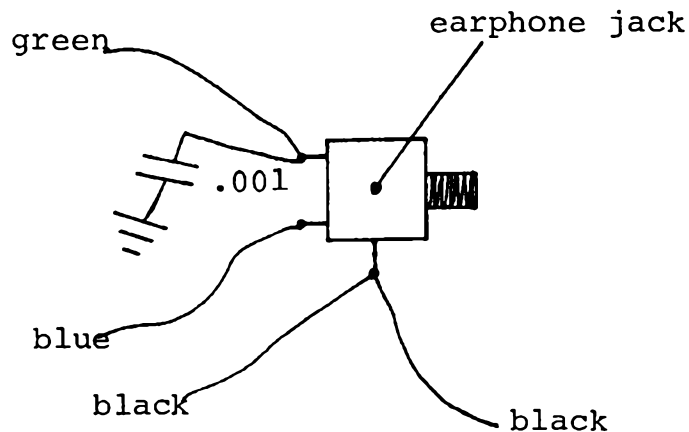

4. Unsolder GREEN wire from earphone jack.
5. Unsolder BLUE wire from earphone jack.
6. Solder GREEN and BLUE wires together and insulate.
7. Cut both BLACK wires off, solder together and insulate.
8. Unsolder WHITE wire from Antenna connector at PC Board. Clean out hole (Note crystal socket!).

Continued on next page.

PRO-22 Pocket Scan AM/FM continued:

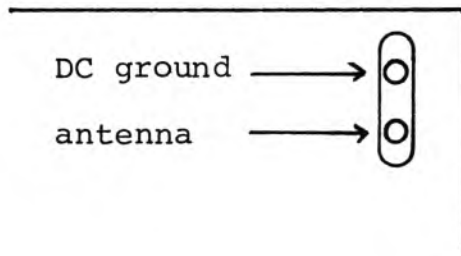

9. Remove .001 capacitor on earphone jack.

NOTE: push wire thru socket to PCB

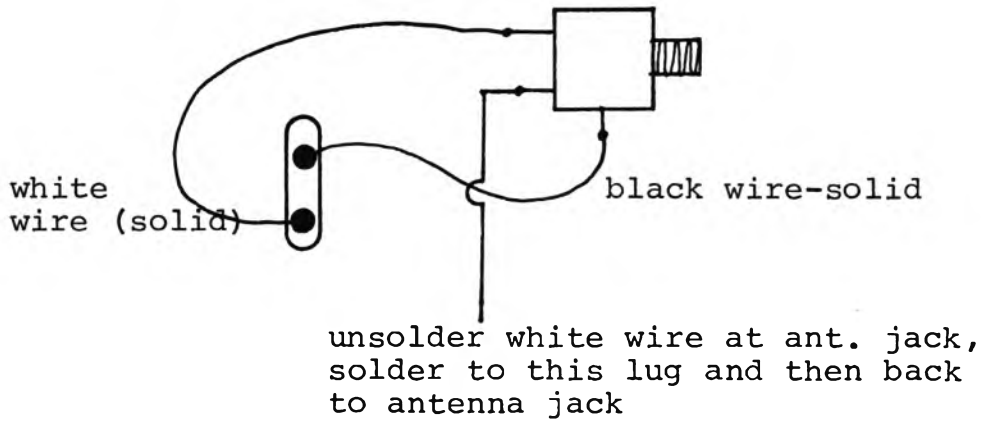

REASSEMBLE. NOTE: Flat washer goes on inside of earphone jack, NOT outside.

MAKE UP AN ANTENNA CABLE LIKE THIS:

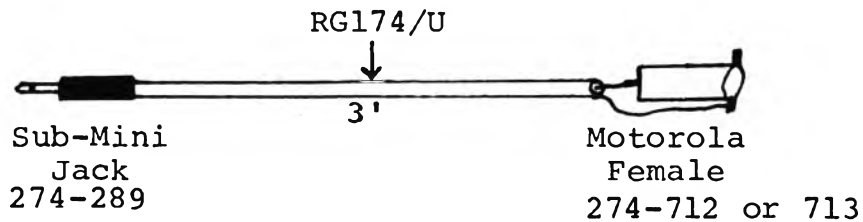

Continued on next page:

PRO-22 Pocket Scan AM/FM continued:

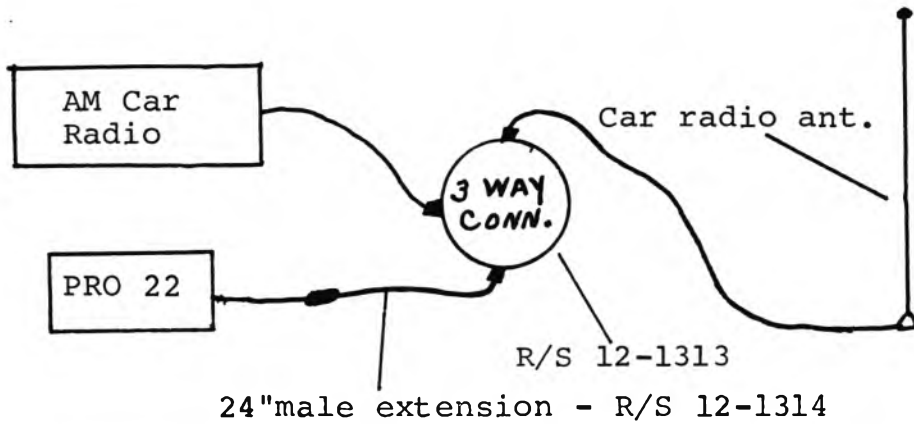

SET WORKS WITHIN 15 MILES OF DOWNTOWN!



"OOPS, WE GOOFED"

VOL. 12, Page 7: MOTOROLA CM555 - Clarifier, Step 1, should read: Cut off the wire on the end of the clarifier pot which reads 8V on RX, 0V TX. Tape it. Run a new wire from the pot where the original wire was to pin 1 of IC702 (+side of C734).

VOL. 13, Page 63: ROBYN T240D -

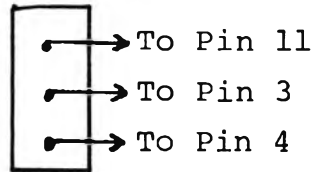

VOL. 14, Page 12: CRAIG L321 - CORRECTED DRAWING - DO NOT CUT the traces as shown before and resistors in new location.

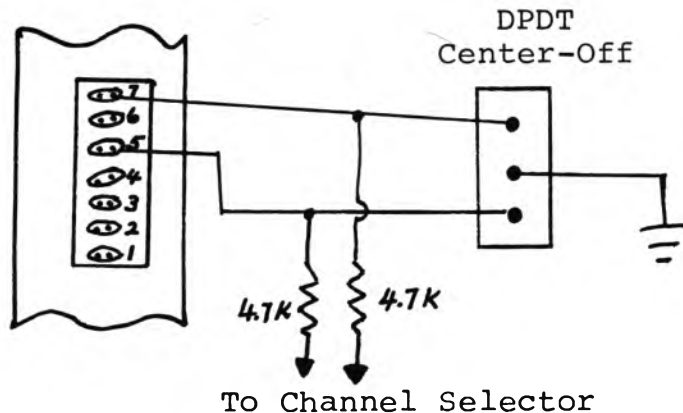

POINTER'S

BEFORE converting/modifying/tune-up, verify that unit does work flawlessly. This can save many headaches! REMEMBER...Just because its "right out of the box" doesn't mean it works. Check it out FIRST. Then proceed carefully.

I recommend doing the following:

1. Check out unit on RX, TX, AM, USB, LSB.
2. Check all functions, RF gain, Squelch, etc.
3. When you are satisfied everything is okay, turn off/unplug, and remove units covers.
4. Proceed with frequency conversion.
5. Adjust VCO, tune-up, check operation.
6. Proceed to Clarifier Mod.
7. Check operation.
8. Reassemble.
9. Retest and verify frequencies.
10. Make frequency chart, mark center on clarifier.
11. Install in customers car (if mobile), set SWR, make contact.
If base, connect to antenna, make contact.

"HELP LINE"

If anyone knows the where abouts of a supplier for SBE parts let us know here at "SECRET CB" so we can spread the word.

HOW TO CONVERT A SALVAGED METER TO A VOLT METER

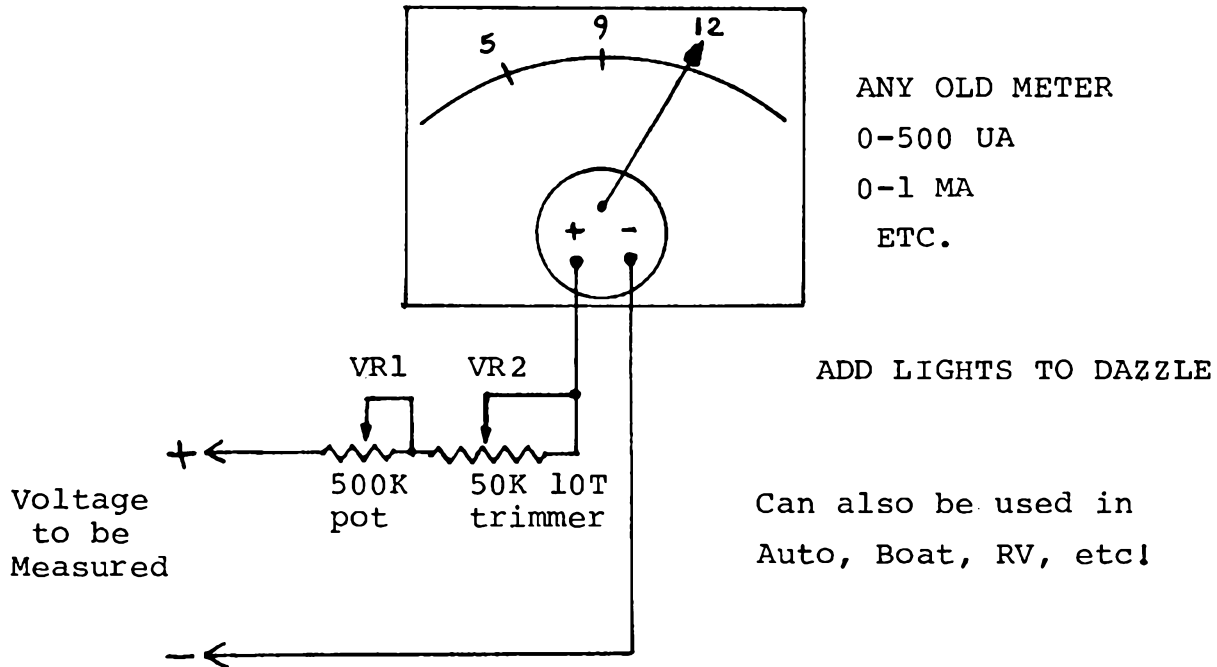

1. Adjust 500K pot for maximum resistance.
2. Adjust 50K trimmer pot to maximum resistance.
3. Hook up leads to a 12 volt power supply. Adjust VR1 for fun scale deflection.
4. Adjust VR2 for where you want 12V to be at on your meter. Put a mark at this location.
5. Hook up leads to a 9 volt battery. Put a mark at this location.
6. Hook up leads to a 5 volt source. Put a mark at this location.

Put a drop of "locktite" on the pots to prevent further movement.
Now you've got a junk box cheapie Voltmeter!

STATE & INTERNATIONAL LOCATION DESIGNATORS

1 DELAWARE	27 FLORIDA	52 QUEBEC	77 ICELAND
2 PENNSYLVANIA	28 TEXAS	53 GREENLAND	78 BERMUDA
3 NEW JERSEY	29 IOWA	54 ONTARIO	79 AUSTRIA
4 GEORGIA	30 WISCONSIN	55 MANITOBA	80 BELGIUM & LUXEMB
5 CONNECTICUT	31 CALIFORNIA	56 SASK.	81 DENMARK
6 MASSACHUSETTS	32 MINNESOTA	57 ALBERTA	82 FINLAND
7 MARYLAND	33 OREGON	58 BRIT COLUMB	83 NETHERLANDS
8 SO CAROLINA	34 KANSAS	59 MEXICO	84 NORWAY
9 NEW HAMPSHIRE	35 W VIRGINIA	60 WEST INDIES	85 PORTUGAL
10 VIRGINIA	36 NEVADA	61 PUERTO RICO	86 SWITZERL & LIECHTENST
11 NEW YORK	37 NEBRASKA	62 PANAMA & CENTR AMER	87 EASTERN EUR
12 NO CAROLINA	38 COLORADO	63 VENEZUELA	88 MIDDLE EAST
13 RHODE ISLAND	39 N DAKOTA	64 BRAZIL	89 INDIA
14 VERMONT	40 S DAKOTA	65 ARGENTINA	90 AFRICA
15 KENTUCKY	41 MONTANA	66 CHILE	91 PACIFIC ISLS
16 TENNESSEE	42 WASHINGTON	67 AUSTRALIA	92 NEW ZEALAND
17 OHIO	43 IDAHO	68 GUAM	93 S E ASIA
18 LOUISIANA	44 WYOMING	69 JAPAN	94 PHILIPPINES
19 INDIANA	45 UTAH	70 ENGLAND	95 REPUB CHINA
20 MISSISSIPPI	46 OKLAHOMA	71 GERMANY	96 MAINL CHINA
21 ILLINOIS	47 NEW MEXICO	72 FRANCE	97 U S S R
22 ALABAMA	48 ARIZONA	73 ITALY	98 MARITIME
23 MAINE	49 ALASKA	74 SWEDEN	99 OTHER AREAS
24 MISSOURI	50 HAWAII	75 IRELAND	
25 ARKANSAS	51 NEW BRUNSW & NOVA SCOTIA	76 SPAIN	
26 MICHIGAN			

SECRET CB INDEX

VOLUMES I THRU 14

CONVERSIONS:

	<u>VOL/PG</u>
Conversion tips for	
all SSB radios.....	9/7
"A" Channel Mod. for	
all SSB.....	9/16-17
Cybernet Freq. Mod.....	8/18
Uniden 8719PLL Mod.....	8/15
MB8719 Mod.....	10/25-26
MB8719 w/11.1125 Mod.	
.....	11/15, UPDATE.14/11-12
PLL01A MOD.....	9/15-17
PLL02A Mod..	4/54-55,3/13-15
23 Ch. PLL02A AM Conv.	
26.645 to 27.275.....	12/32
Tech tips on the	
858 Chassis.....	10/55
Uniden 858 update.....	9/8-11
How to get on 28 & 29 MHz	
w/uPD858 PLL.....	11/4-7
uPD858 AM Conv.....	11/35
Receiver Widebanding	
for 858 Chassis.....	13/34
NEW Thumbwheel Conversion	
for 858 Chassis...13/35-37	
How to increase ANL	
efficiency 70%.....	11/8
Ham Radio Crystal	
Selector.....	12/24
<u>BOWMAN</u>	
CB910.....	11/41,13/58
CB920.....	14/43
CB930.....	3/21
CB950.....	5/39
<u>BROWNING</u>	
Mark III.....	6/28
Mark IV.....	14/6,6/29-30
Mark IVA.....	14/5
Mark IV,IVA.....	7/8-14
Sabre.....	1/27
<u>CHANNEL MASTER</u>	
CB6830.....	14/41
<u>COBRA</u>	
CAM89.....	14/45-46
32XLR.....	4/47
132B.....	1/53
132XLR.....	4/47
135B.....	1/53
135XLR.....	4/38
135XLR Update.....	10/43-46
138XLR.....	1/20-23
139XLR.....	1/20-23
140GTL3/19-20,4/50,10/28-29	
142GTL.....	4/50,10/28-29
146GTL.....	11/17-18
148GTL.....	8/16
2000 (C.A.P.).....	6/23
2000GTL.....	5/20,7/15-17
<u>COLT</u>	
SK33.....	3/4-7
290.....	3/4-7
390.....	3/4-7
480.....	3/8-15, 5/39
485.....	3/8-15
800.....	3/4-7
1000.....	3/8-15

CONVERSIONS:

	<u>VOL/PG</u>
<u>COURIER</u>	
Centurion PLL....	1/31,61-62
.....	5/57
Centurion 40D.....	10/53
Galaxy.....	5/53-54,7/18-22
Gladiator PLL....	1/31,61-62
.....	5/55-57
Spartan.....	1/61-62
.....	5/30,53,55,57
<u>CPI</u>	
300.....	8/21
400.....	8/21
2000.....	3/25
2000 Low.....	9/23
2500.....	5/37-38
<u>CRAIG</u>	
L131 & L231.....	9/12-14
L132 & L232.....	9/12
L232 & L132 w/uPD2824C	
Chip.....	10/47,11/10
L132L.....	14/12
<u>DAK</u>	
IX.....	5/21-23
IX Mod. Update.....	9/18-19
X.....	4/39-46
<u>DELCO</u>	
Delco Factory AM/FM/CB	
Combo Unit.....	11/38-40
DM83.....	12/26
90BFMCL.....	12/26
90BFPCl.....	12/26
91YFMCL.....	12/26
<u>DEMCO</u>	
Star II.....	5/60
Super Satellite.....	5/60
<u>FANON</u>	
Fanfare 350.....	5/57
<u>FIELDMASTER</u>	
Micro Mini 40.....	11/37
<u>GENERAL ELECTRIC</u>	
Superbase 3-5875/A....	10/48
3-5813A/3-5869A.....	14/41
<u>GEMTRONICS</u>	
GTX77.....	5/39
<u>HALLICRAFTERS</u>	
HCM271.....	5/50-51,6/39
<u>HYGAIN</u>	
I-A.....	1/22
PLL.....	1/32
II.....	8/20
<u>ITT</u>	
CB-4000M.....	13/61
CB-4400M.....	4/17-18
<u>J.C. PENNEY</u>	
6246.....	13/61
6248.....	8/24

CONVERSIONS:

	<u>VOL/PG</u>
<u>JOHNSON</u>	
242-4730.....	10/49-51
4125/4174.....	13/61
4740 (NDC40013).....	11/12
<u>KENWOOD</u>	
TS-120S.....	12/22
TS-130.....	12/23
TS-820S.....	14/7-8
<u>KRACO</u>	
KCB2330A.....	9/15
<u>LAPAYETTE</u>	
SSB75.....	14/9
<u>MECTRON</u>	
ME502.....	14/41
<u>MIDLAND</u>	
CAP 858.....	5/30
13-857.....	11/36
13-862.....	14/48-49
13-882C (02A).....	13/62
13-883B (uPD858).....	12/4
77-861.....	12/26
78-574.....	14/10
79-893.....	2/20
79-900.....	5/47
6001.....	11/16
7001.....	8/21,11/16
<u>MORSE</u>	
3005.....	2/27
<u>MOTOROLA</u>	
CB555 (TC9105P).....	12/7
T4025A.....	10/46
<u>NESCO</u>	
1249.....	6/38
<u>PACE</u>	
8092.....	6/35-36
<u>PALOMAR</u>	
500.....	4/19-20,5/32-36,8/21
<u>PANASONIC</u>	
RJ3600.....	10/57
RJ3700.....	13/16-17
<u>PEARCE-SIMPSON</u>	
Cheetah PLL.....	1/31-32
Simba PLL.....	1/31-32
<u>PRESIDENT</u>	
Adams.....	2/16,13/18-20
AR144.....	11/17-18
Grant.....	1/22-23,59
.....	2/17,23-26
Grant (NEW).....	5/24-27
.....	13/21-22,14/13-17
Honest Abe.....	1/60
John Q.....	1/60
Madison w/11.3258.....	10/30
McKinley.....	4/12-13
McKinley w/11.1125.....	10/29
Teddy R.....	1/60
Washington.....	1/22-23,59

CONVERSIONS:

	<u>VOL/PG</u>
<u>PRESIDENT (cont.)</u>	
Washington w/11.1125	
(NEW).....	10/28-29
Zachary T.....	1/60
<u>RCA</u>	
14T302.....	5/11,39
14T302 (PLL 02AG).....	4/36
<u>REALISTIC</u>	
TRC-57.....	12/28
TRC-431.....	7/23-24
TRC-448 (REC86345).....	11/19
TRC-450.....	10/31
TRC-451.....	12/10-13
TRC-455 (SM5104).....	12/30
TRC-457.....	10/36
TRC-459.....	10/32-35
TRC-480.....	10/37-38
TRC-490.....	12/14-15
<u>RAY JEFFERSON</u>	
CB845 (02A).....	12/27
<u>ROBYN</u>	
GT-440D.....	1/23
SB-505.....	5/41-42
SB-520D.....	2/21-22
SB-540D.....	5/19,36,7/25-28
WV-23.....	1/24-25
WV-110 (SM5104).....	12/31
<u>ROYCE</u>	
1-601.....	1/26
1-612.....	5/45-46
1-632.....	11/21
1-632 Update.....	13/23
1-641.....	11/20
1-642.....	13/24
<u>SANKYO</u>	
SCS-555.....	11/40
<u>SBE</u>	
Console IV.....	2/28-35
Console V.....	2/28-37
Console VI.....	8/14
Cortez 21CB.....	14/56-57
Formula D.....	1/49
LCBS-4.....	7/29-33
LCMS-4.....	7/34-37
Sidebander II.....	2/28-35
Sidebander V.....	2/36-37
Sidebander VI.....	8/14
Touch Com.....	1/50-51
<u>SEARS</u>	
D63911 w/uPD861C.....	12/26
562-38220700.....	10/56
663-3810 w/2824.....	11/22
934-3677150.....	12/16-17
934-36772600.....	12/16-17
934-38260700.....	6/26-27
934-38260700 Update.....	11/23
934-38270700.....	5/28-29
934-38270700 Update.....	9/20-22
<u>SHARP</u>	
CB-5470 HD42851B3.....	11/24

CONVERSIONS:

SILTRONIX
1011C.....1/46
1011D.....1/46

SOMMERKAMP
TS-788DX.....13/25-30

SONAR
FS-2340.....5/31

SPARKOMATIC
CB4020S.....14/41

STANDARD HORIZON
29-A.....5/59,13/63

STONER
Pro-40.....4/52-53

SUPERSCOPE AIRCOMMAND
CB340.....8/19
CB340 (861 Update).....9/24

SWAN SIGNET
270.....5/58

TEABERRY
52 Ch. Capability.....1/43
CAP Mod.....5/30
Model T.....4/3-4
Racer T.....1/58
Ranger T.....4/1-2,6/24-25
Stalker I.....1/57,4/5-6,10-11
Stalker IX.....4/7-9
Stalker XV.....4/7-9,10/39
Stalker XX.....10/40
T Bear.....4/14-15
T Dispatch.....4/14-15
Titan T.....4/14-15

TRAM
D12.....10/56
D42.....4/47,5/40
D60.....1/53
D64.....13/31
D80.....10/30
D201.....1/56,3/22-23,4/48
D201A Update.....10/54
D300.....8/11-13

TRS CHALLENGER
850/1400.....4/21-27,32-35

VECTOR
770.....4/56-57
790.....4/58-59

WARDS
719A w/uPD2824.....11/10

YAESU
101.....5/58
FT-7B.....7/38-41
FT-707.....10/20-24
FT-901.....6/3-12

SLIDE MODIFICATIONS:

BOWMAN
950.....4/49

COBRA
29GTL.....13/57
132-A.....1/28
132XLR.....10/45-46
135-A.....1/28
135-B.....1/29
135XLR...4/38,8/38,10/45-46
138.....1/28
138XLR.....1/23
139.....1/30
139XLR.....1/23
140GTL.....4/50,6/64,10/28
142GTL.....4/50,6/64
.....8/35-37,10/28
146GTL.....10/41,11/17
148GTL.....8/16
2000GTL.....12/20,13/40

COLT
480.....3/11
485.....3/11,4/49
1000.....3/11

COURIER
Centurion.....1/61,5/55
Centurion 40D.....10/53
Galaxy.....5/53,7/19
Gladiator PLL.....1/61,5/55
Spartan.....1/61,5/55

CPI
2500.....5/37

CRAIG
L-131.....9/12-14
L-132 uPD2824C...9/12,10/47
L-231.....9/12-14,12/3
L-232.....9/12,10/47,11/10
L321.....14/12

DAK
X.....4/45

PANON
Panfare 350F.....5/55

GENERAL ELECTRIC
3-5875A.....10/48

GEMTRONICS
GTX-77.....4/49

HYGAIN
V.....11/11
623.....1/33
674-A.....4/60

J.C. PENNEY
Pinto SSB.....1/44
6248.....13/14-15
981-6247.....13/13

JOHNSON
242-4730.....10/50
352.....1/34
4740.....11/12

LAFAYETTE
SSB75.....14/9

MIDLAND
13-883B.....12/4

SLIDE MODIFICATIONS:

MIDLAND (cont.)
13-892.....4/48,11/13
13-893.....4/51
13-898.....1/36
13-898B.....1/35
78-574.....14/10
78-999.....12/5
79-891.....12/6
79-892.....11/14
79-900.....5/47
6001.....11/16
7001.....8/21,11/16

MOTOROLA
CB-555.....12/7

N.D.I.
PC-201 (NDC40013PLL)...12/8

PACE
1000.....1/37-38
DX1023B.....1/39
8092.....6/37
8193 (CC13001).....12/9

PALOMAR
500.....4/19,5/32,35

PANASONIC
RJ-3700.....13/16-17

PEARCE-SIMPSON
Bengal.....1/40
Cheetah.....1/40
Simba.....1/40

PRESIDENT
ARI44.....10/41
Adams.....1/16
Adams 858.....13/18-20
Grant.....1/59,2/23
Grant (NEW).....5/24,8/34
Grant MB8719.....13/21-22
Madison (NEW).....10/30
McKinley.....4/12,6/64
McKinley (NEW).....10/29
Washington.....1/59
Washington (NEW).....6/64
.....8/33-34,10/28

RCA
14T302.....4/49

REALISTIC
TRC-47.....1/41
TRC-48.....1/42
TRC-57.....12/28
TRC-448.....11/19
TRC-450.....10/31
TRC-451.....12/10
TRC-457.....10/36
TRC-458.....8/39-40
TRC-459.....10/34
TRC-480.....10/38
TRC-490.....12/14-15

ROBYN
SB-505.....5/41
SB-540D.....5/19
T240D.....13/63

ROYCE
1-632.....5/14,11/21,13/23
1-641.....4/51,11/20
1-642.....13/24

SLIDE MODIFICATIONS:

SANKYO
SCS-555.....11/40

SBE
Console II.....1/48
Console IV.....2/34,38-40
Console V.....2/34,38-40
LCBS-4.....7/30
LCMS-4.....7/34
Sidebander II.....1/47
Sidebander IV.....2/34,38-40
Sidebander V.....2/34,38-40

SEARS
23 Ch. SSB.....1/44
Roadtalker SM5104....12/18
663-3810.....11/22
934-3677150.....12/17
934-36772600.....12/17
934-38260700.....10/52
934-38270700.....5/28,9/20
934-38310700.....5/19,9/22

SHARP
CB5470.....11/24

SILTRONIX
SSB.....1/45

STONER
Pro-40.....4/52,53

TEABERRY
Stalker IX.....4/7-8
Stalker XV.....4/7-8
Stalker XV.....10/39
Stalker XX.....10/40
Stalker 101/202.....4/10

TRAM
D60.....1/52
D62.....10/45-46
D64.....13/31
D300.....12/19

TRS CHALLENGER
850/1400.....4/33

TRUETONE
CYJ4837A-87.....11/14

WARDS
GEN-719A.....11/10

SPECIFIC RADIO TUNEUPS:

AIR COMMAND
CB640.....5/38

ALARON
B-4075.....9/30
B-4900.....9/30
B-5050A.....9/30
B-5200.....3/41

AMERICAN MOTORS
3221847/48/49/50.....12/34

AUDIOVOX
MCB750.....3/41
MCB5000.....11/42
MDV6000.....6/18

SPECIFIC RADIO TUNEUPS:	VOL/PG
<u>AUTOMATIC</u>	
CBH2265.....	3/41
<u>BOMAN</u>	
CB555.....	3/44
CB750.....	2/43
CB755.....	14/44
CBH900.....	3/44
CB910.....	1/21,3/44
CB920.....	1/21,14/43
CB930.....	1/21,3/44
CB950.....	3/43
CBH990.....	5/43
CBR9600.....	2/42,3/41
CBR9940.....	3/44
CBR9950.....	10/58
<u>BROWNING</u>	
SABRE.....	14/42
<u>CHANNEL MASTER</u>	
CB6834.....	14/44
CB6835.....	6/18
<u>CHRYSLER</u>	
4048076/8077.....	6/18
<u>CLARION</u>	
DMA066.....	3/45
JC202E.....	3/45
RCJ003.....	3/45
TC203E.....	6/18
<u>COBRA</u>	
CAM89.....	14/45
19.....	7/51
19GTL.....	12/34
21GTL.....	3/41,58
21XLR.....	1/20
21XLR Update.....	10/58
25GTL.....	3/41,58
29GTL.....	3/45,14/42
29LTD.....	13/59
29XLR.....	1/20
32XLR.....	3/58
45XLR.....	12/34
46XLR.....	3/43
47XLR.....	3/45
50XLR.....	3/43
55XLR.....	3/43
66GTL.....	10/58
77X.....	9/30
78X.....	4/49,6/19,8/44
86XLR.....	3/45
87GTL.....	6/19
89GTL.....	6/18
132XLR.....	3/45
135XLR.....	3/45,4/38
138XLR.....	1/20
139.....	1/20
139XLR.....	1/20
140GTL.....	3/20,58,4/50
142GTL.....	4/50
146GTL.....	10/41
148GTL.....	6/19
1000GTL.....	6/18,14/42
<u>COLT</u>	
222.....	6/20
290.....	3/4
350.....	14/46
390.....	3/4
480.....	3/8,58
485.....	3/8,6/19

SPECIFIC RADIO TUNEUPS:	VOL/PG
<u>COLT (cont.)</u>	
800.....	3/4
800 Update.....	10/58
1000.....	3/8,58
1200.....	9/30-31
<u>COMMANDO</u>	
2340.....	1/21
<u>CONVOY</u>	
CON-400.....	3/58
<u>CPI</u>	
CP400.....	10/59
<u>COURIER</u>	
Blazer 40D.....	3/58
Centurion 40D.....	10/53,13/10
Classic PLL40.....	3/43
Classic PLL40 Update.....	10/59
Galaxy.....	5/53
Nightrider 40DR.....	3/46
Rangler 40D.....	3/58
Redball.....	1/21
Renegade 40.....	3/46
Rouge 40.....	3/43
<u>CRAIG</u>	
L101.....	6/20,11/42
L102.....	6/20
L131.....	10/59
L132.....	9/12,10/47
L231 (AM,SSB).....	10/60
L232.....	10/47,11/10
<u>DAK</u>	
Mark II.....	10/60
Mark V.....	12/34
Mark X.....	4/45
<u>DELCO</u>	
70BFMC3.....	2/43
80BCB2.....	6/20
90BCB1.....	10/60
90BFMC1.....	12/26
90BFPC1.....	12/26
90BFTC1 (FM,AM,CB).....	10/60
91YFMC1.....	12/26
<u>FANON</u>	
10-40.....	6/20
Fanfare 125F.....	3/43
Fanfare 182F.....	3/41
Fanfare 184DF.....	3/47
Fanfare 185PLL.....	3/46
Fanfare 190DF.....	3/47,7/51
Fanfare 350F.....	3/47,13/12
<u>FORMAC</u>	
40.....	10/60
<u>GENERAL ELECTRIC</u>	
3-5800A.....	3/50
3-5804B.....	6/21
3-5804F.....	10/61
3-5804G.....	12/35
3-5805A.....	9/31,10/61
3-5811B.....	9/31,10/61
3-5812A.....	10/61
3-5814B.....	6/21
3-5817A.....	7/51
3-5818A.....	2/42
3-5819A.....	11/42
3-5821A.....	9/31

SPECIFIC RADIO TUNEUPS:	VOL/PG
<u>GENERAL ELECTRIC (cont.)</u>	
3-5821B.....	3/54
3-5825A.....	9/31-32
3-5830.....	3/42
3-5869A.....	2/42
3-5871A.....	13/60
3-5871B.....	3/46
3-5875A.....	9/32,10/48
3-5900A.....	12/35
<u>GEMTRONICS</u>	
GT44.....	2/42
GT55.....	3/48
GTX66.....	6/21
GTX77.....	6/21
GTX4040.....	3/48
GTX5000.....	3/42,13/60
<u>GENERAL MOTORS</u>	
CBD-20U (PLL03A).....	12/36
CBD-20J.....	3/48
4120.....	3/46
4145.....	9/32
4175.....	3/46
<u>HYGAIN</u>	
VIII.....	3/59
674A.....	4/60
V674B.....	1/21
2701.....	2/42
2702.....	3/48
2703.....	3/48
2716.....	12/36
<u>ITT</u>	
4000M.....	13/61
4400M.....	4/17
<u>J.C. PENNEY</u>	
6246.....	13/61
981-6204.....	9/32
981-6225.....	14/47
981-6248.....	13/14-15
981-7461.....	9/32
981-8360.....	10/61
<u>JIL</u>	
615CB.....	11/42
<u>JOHNSON</u>	
123A.....	1/21
4125/4174.....	13/61
Messenger 40.....	12/36
Messenger 50.....	7/51
Messenger 80.....	7/51
Messenger 4120.....	3/47
Messenger 4135.....	3/48
Messenger 4140/4145.....	3/54
Messenger 4170/4175.....	3/47
.....Update.....	11/43
Messenger 4250.....	3/48
Viking 200.....	12/36
Viking 260/270.....	3/49
Viking 4330/4360.....	11/43
Viking 4740.....	11/12
<u>KRACO</u>	
KB4045.....	14/47
KCB-2340.....	2/42
KCB-4000.....	11/43
KCB-4003.....	3/42
KCB-4005.....	9/38,11/43
KCB-4020.....	3/49
KCB-4030.....	8/44
KCB-4088.....	3/50

SPECIFIC RADIO TUNEUPS:	VOL/PG
<u>KRIS</u>	
XL25.....	2/43
<u>LAFAYETTE</u>	
Comstat.....	11/45
Dyna-Com 40.....	11/44
HB640.....	2/43
LM-100 (PLL02A).....	12/36
LM-300.....	12/37
SSB75.....	14/9
SSB140.....	11/44
Telestat 1240.....	5/14
<u>LAKE</u>	
410.....	12/37
450.....	12/37
600.....	12/37
<u>MEDALLION</u>	
63-240.....	3/50
<u>MIDLAND</u>	
100M.....	10/67
102M.....	14/42
150M.....	7/52
13-858.....	14/42
13-862.....	14/48
13-867.....	13/62
13-879.....	14/50
13-882C.....	13/62
13-892.....	4/48
13-893.....	4/51
63-445.....	11/45
76-858.....	3/49
76-860.....	14/51
76-863.....	3/50,9/33
77-101B.....	8/44
77-101C.....	12/38
77-821.....	3/42
77-824.....	8/44
77-824B.....	12/38
77-824C.....	12/39
77-838.....	9/33
77-849.....	3/50
77-856.....	11/45
77-861.....	3/50
77-861B.....	11/45
77-865.....	9/33
77-899.....	9/33
77-963.....	3/42
78-574.....	9/38,12/39,14/10
78-999 (02A).....	12/5
79-891 (02A).....	12/5
79-892.....	3/49
79-893.....	2/20
79-900.....	9/33-34
3001.....	12/37
4001 (77-004).....	7/52
5001.....	12/37
6001.....	11/16
7001.....	11/16
7001 (79-007).....	11/45-46
<u>MOPAR</u>	
4094173.....	3/51
4094176.....	3/51
4094177.....	3/49
4094178.....	3/60
<u>MORSE</u>	
2001.....	12/42
<u>MOTOROLA</u>	
CB555.....	12/7
CF925AX.....	11/46

SPECIFIC RADIO TUNEUPS:

	<u>VOL/PG</u>
<u>MOTOROLA (cont.)</u>	
Mocat 40.....	11/46
T4000A/05A/10A/20A.....	3/50
<u>N.D.I.</u>	
PC-102.....	11/46
PC-200.....	7/52
PC-201.....	12/8
<u>PAGE</u>	
CB144.....	14/42
8003.....	11/47
8008.....	2/43
8016.....	11/47
8046.....	9/33
8113.....	12/39
8117.....	11/47
8155.....	9/34,12/40
8193.....	7/52
<u>PALOMAR</u>	
49.....	3/60
500.....	4/19,5/32
4100.....	3/54
<u>PANASONIC</u>	
CR-B474EU (AM,FM,CB)...	9/34
RJ-3200.....	14/42
RJ-3250.....	11/47
RJ-3600.....	11/48
RJ-3660.....	14/52
RJ-3700.....	13/17
<u>PEARCE-SIMPSON</u>	
Cougar 23.....	14/53
Leopard B.....	3/49
Puma 23B.....	13/62
Supertiger 40A.....	3/60
Tiger 40A.....	9/34
<u>PIONEER</u>	
GT-100G (AM,FM,CB)....	10/62
<u>PRESIDENT</u>	
AR-7.....	12/40
AR-44.....	10/63
AR-144.....	10/41
AR-711.....	12/34
AX-7.....	12/45
AX-11.....	12/45
AX-14.....	12/45
AX-44.....	12/45
AX-52.....	12/45
AX-55.....	12/45
AX-144.....	12/45
AX-711.....	12/40,45
Adams.....	2/16
Andrew J.....	9/34
Dwight D.....	10/62,14/54
Grant.....	1/22
Grant (NEW).....	5/24
James K.....	7/52
James K (NEW).....	12/40
McKinley.....	4/12
Old Hickory.....	9/34
Washington.....	1/22
Zachery T.....	14/54
<u>RAY JEFFERSON</u>	
CB-845.....	11/48
<u>RCA</u>	
14T270.....	9/36
14T300.....	2/43

SPECIFIC RADIO TUNEUPS:

	<u>VOL/PG</u>
<u>RCA (cont.)</u>	
14T302.....	3/53
14T303.....	11/48
<u>REALISTIC</u>	
TRC-45A.....	4/37
TRC-47.....	1/21
TRC-57.....	1/21,12/28
TRC-99A.....	4/37
TRC-100.....	4/37
TRC-180.....	4/37
TRC-200.....	4/37
TRC-200 Update.....	10/63
TRC-204.....	10/63
TRC-205.....	12/40
TRC-206.....	14/55
TRC-209.....	10/63
TRC-209(GRE7189PLL-VC)12/49	
TRC-410.....	12/29
TRC-420.....	12/41
TRC-421.....	8/44,12/41
TRC-421A.....	9/35
TRC-422.....	8/45
TRC-422A.....	10/64,67
TRC-424.....	3/57,9/35
TRC-425.....	7/53,10/67
TRC-426.....	10/64
TRC-427.....	8/45
TRC-428.....	11/48
TRC-431.....	4/37
TRC-432.....	11/48
TRC-440.....	8/45,9/35
TRC-441.....	10/67,11/49
TRC-448.....	3/51,10/64,11/19
TRC-449.....	3/51,9/35-36
TRC-451.....	12/10
TRC-452.....	1/21,3/52
TRC-454.....	8/45
TRC-455.....	3/60
TRC-456.....	10/67
TRC-457.....	9/35-36,10/36
TRC-458.....	9/35
TRC-459.....	10/34
TRC-461.....	3/51
TRC-462.....	9/36
TRC-466.....	3/51
TRC-468.....	3/57
TRC-470.....	9/39,12/41
TRC-471.....	8/45
TRC-480.....	7/53,10/37
TRC-490.....	11/49,12/15
<u>ROBERTS</u>	
40 Ch.....	14/42
<u>ROBYN</u>	
007-140.....	3/52
AM500D.....	3/52
DG130D.....	3/56
GT-410D.....	3/57
LB120.....	3/52
SB-505.....	5/42
SB-520D.....	2/22
SX-401.....	3/57
SX-402D.....	3/57
T240D.....	3/56,13/60,63
WV110.....	3/56
WV110 Update.....	11/50
<u>ROYCE</u>	
582 (PLL3001).....	12/42
604.....	3/56-57
607.....	12/42
611.....	14/55
1-617.....	3/52

SPECIFIC RADIO TUNEUPS:

	<u>VOL/PG</u>
<u>ROYCE (cont.)</u>	
1-619.....	3/56
1-621.....	3/57
1-625.....	3/56
1-632.....	11/21
1-639.....	12/41
1-641.....	3/60,4/51,11/20
1-642.....	13/24
1-650.....	14/42
1-651.....	7/55
1-655.....	11/50
1-660.....	2/42
1-673.....	3/52
1-675.....	3/53
1-680.....	3/52
<u>SBE</u>	
21-CB Cortez.....	14/56
26CB1A.....	3/61
42CB Cortez 40.....	3/61
43CB.....	3/53
44CB.....	9/36
45CB Trinidad III.....	3/61
47CB.....	3/53
49CB Tahoe 40.....	3/53
LCB-8 (uPD2826C).....	12/43
LCBS-4.....	7/32
LCM-5 Land Command.....	9/36
LCM-8.....	9/36
LCM-8 (PLL03A).....	12/42
LCMS-4.....	7/35
LCMS-8 (uPD2816C).....	12/43
<u>SEARS</u>	
CM-6000LA.....	3/59
CM-6000LC.....	3/59
Roadtalker 40.....	2/43
370-38050700.....	3/54
562-38200700.....	3/55
663-38020800.....	7/53
663-38070700.....	3/61
663-3810.....	11/72
663-381050.....	11/21
934-3677150.....	12/16
934-36772600.....	12/16
934-38061700.....	11/50
934-38062700.....	10/65
934-38080700.....	9/37
934-38081700.....	9/38
934-38120700.....	3/61
934-38260700.....	7/53
934-38270700.....	7/54
934-38310700.....	7/54-55
<u>SHAKESPEARE</u>	
GBS240.....	3/53
<u>SHARP</u>	
CB-23.....	13/63
CB-800.....	2/42
CB-2170.....	12/43
CB-4370.....	12/43
CB-4470.....	12/44
CB-4670.....	7/55
CB-5470.....	11/24
<u>SONAR</u>	
FS-2340.....	5/31
<u>SPARKOMATIC</u>	
SR-42/CBM.....	3/54
<u>STANDARD</u>	
29.....	1/22
29A(uPD857).....	13/63

SPECIFIC RADIO TUNEUPS:

	<u>VOL/PG</u>
<u>SUPERSCOPE</u>	
Aircommand CB1040.....	14/57
<u>SURVEYOR</u>	
620.....	3/55
2610.....	3/54
<u>TEABERRY</u>	
Model T.....	3/55
Racer T.....	3/55
Stalker II.....	1/21
Stalker III.....	7/55
Stalker IV.....	12/44
Stalker V.....	7/55
Stalker VIII.....	10/65
Stalker IX.....	10/65
Stalker XII.....	7/56
Stalker XV.....	10/39
Stalker XX.....	10/40
T Charlie.....	10/65
T Command.....	3/55
T Dispatch.....	3/55
<u>TENNA</u>	
10901.....	10/58
10902.....	10/65
11302 (AM,FM,CB).....	9/37
<u>TRS</u>	
Challenger 432.....	4/23
Challenger 460.....	14/59
Challenger 600.....	9/37
Challenger 850.....	4/32,7/55
Challenger 1200.....	12/44
<u>TRAM</u>	
D12.....	3/54
D64.....	13/31
<u>TRUETONE</u>	
CYJ4832-A-87.....	2/43
CYJ4837-A-87.....	3/59
CYJ4862-A-87.....	9/39
MCC4434A-57.....	14/60
<u>UTAC</u>	
TRX-400.....	3/59
TRX-500.....	5/56
<u>VECTOR</u>	
X.....	2/43
770.....	9/37
790.....	9/37
<u>WARDS</u>	
GEN-680A.....	14/61
GEN-696A.....	14/61
GEN-719A.....	11/10
GEN-775A.....	3/61
<u>XTAL</u>	
XSSB10.....	1/22

VOLUME 1

	PAGE #
GOLDEN EAGLE MARK IV PING MODIFICATION.....	20
CRYSTAL CROSS REFERENCE GUIDE.....	5-10
LETTER CHART FOR CRYSTAL FREQ. CORRELATION.....	11-18
GENERAL INFORMATION.....	63-67
LINEARS.....	68-70

VOLUME 2

	PAGE #
NEW CRYSTAL CROSS REFERENCE GUIDE.....	5-9
LETTER CHART FOR CRYSTAL FREQ. CORRELATION.....	10-13
PRESIDENT GRANT RF GAIN & ADJACENT CH. REJ. MOD.....	18-19
ROBYN 510D/520D NOISE BLANKER ALIGNMENT.....	25-26
COBRA 139XLR SERVICE BULLETIN ON CRYSTAL DRIFT PROBLEM & PCB CRACKING.....	45-50
SERVICE BULLETIN ON SIDEBANDER II & CONSOLE II FOR IMPROVING CROSS MODULATION REJECTION.....	51
SERVICE BULLETIN-COBRA 29 ON MODULATION IMPROVEMENT, ALSO NOISE BLANKER.....	52
ANTENNA REPORTS.....	53-55
BETA-COM INFO (UPGRADING 23 CHANNEL RADIOS).....	57-87

VOLUME 3

	PAGE #
PRESIDENT MADISON FREQ. COUNTER MOD.....	16-18
NOISE WHINE CURE.....	24
MICROPHONE WIRING INSTRUCTIONS.....	26-32
PLL CHANNELIZER.....	33-40
ANTENNA SECRETS (K40 STUD MOUNT FOR BIG STICK).....	63-64
SPECIAL SECTION ON LINEAR AMPLIFIERS:	
50-70W MOBILE.....	66
300-400W BASE.....	67-69
70W BASE.....	70-71
EAGLE 200.....	72
EAGLE 500.....	73
CONVERSION FROM AMATEUR TRANSMITTER TO LINEAR AMP...	74
LINEAR AMP PROBLEMS & SOLUTIONS.....	75-76

VOLUME 4

	PAGE #
HOW TO BUILD YOUR OWN RELAY MODULE.....	16
02A CHIP INFORMATION.....	54-55
HINTS & KINKS ON COBRA 62XLR & 142GTL.....	61
TURNER MIC EXPANDER (500AMC DISABLE).....	62
K40 BLINKIE.....	63
SUNSPOT PREDICTION CHART.....	64
LINEAR REPORT SECTION:	
D & A MAVERICK.....	65
D & A 500 TRIPLE CONVERSION.....	65
EAGLE 515 MODIFICATION.....	66-67
UNIDEN SSB 10METER POWER CONVERSION.....	68-70
SUPER CLARIFIER DIODE.....	71

VOLUME 5

	PAGE #
10 METER CONV. MICROCOMPUTER (MICROMONITOR PLL).....	1-5
ECHO BOX.....	6
250 WATT DUMMY LOAD - "SECRET CB'S LITTLE DUMMY"....	7
BUILT IN POWER MIKE.....	8-9
5-MILE SIMULATOR.....	10
RECEIVER PRE-AMP.....	11
GLEN DIGITAL CONTROLLER.....	12-13
GETTING SWR DOWN ON BASE ANTENNAS.....	15
APARTMENT ANTENNA.....	16
GROUNDING MOBILE RADIOS.....	17
OOPS! WE GOOFED!	
VOL. 1, PAGE 23.....	18
VOL. 2, PAGE 20 & 21.....	18
VOL. 3, PAGE 4, 7, 11, 25, 33.....	18
VOL. 4, PAGE 5, 45, 50.....	17

VOLUME 5 (cont.)

	PAGE #
DAK MARK IX POWER MODIFICATION.....	21-23
SUPER POWER MODULATION MOD. FOR BOWMAN BASE CBH990..	43
THE ART OF WIDEBANDING 858 CHIP.....	44
CONVERSION KIT + MARS & CAP FOR SSB.....	48-49
CONVERSION OF AM/SSB TO 10 METER AMATEUR.....	52
REDCO UFO INSTALLATIONS.....	61-69
HINTS & KINKS - COBRA 140/142/148GTL REGUALTOR IC SHORTING OUT.....	70
SLIDE INCREASE, ALL SSB RADIOS.....	71
RADAR COMMUNICATOR.....	72-73

VOLUME 6

	PAGE #
PLL CRYSTAL CROSS REFERENCE GUIDE.....	1-2
SECRET CB TEST TONE.....	13
ERRONEOUS SIGNAL LOCATOR.....	14
LOW COST AMATEUR CONVERSION FOR 10 METERS.....	15
BASE ANTENNA GROUNDING.....	16-17
SUPER CLARIFIER 10-TURN POT.....	22
OOPS! WE GOOFED!	
VOL. 5, PAGE 19, 20, 28.....	25
THUMBWHEEL 200 CHANNEL CONVERSION FOR 858 CHASSIS..	31-34
REDCO UFO APPLICATIONS.....	40-52
SPECIAL SECTION ON LINEAR AMPLIFIERS:	
PDX 400.....	54
D & A MAVERICK 250.....	55
MACO DUSTER 300, 750 & 1000 TRANSMITTER.....	56-57
MACO 75.....	58
500 CX & 700 CX 10 to 11 METER CONVERSIONS.....	58
RDX-75.....	59
HDX-50.....	59
MDX-200.....	60
PDX-400.....	61
10 METER EXPERIMENTER BOARD INFORMATION.....	62-63
HOW TO MAKE CYBERNET CHASSIS SLIDE.....	65
HOW TO HOOK UP GLEN 310 TO PRESIDENT WASHINGTON....	67
SUPER CLARIFIER HINTS.....	66
REDCO DX-50.....	68-70

VOLUME 7

	PAGE #
HOW TO MAKE YOUR EAGLE SCREAM.....	14
IMPROVED SLIDE MODIFICATION FOR 02A SSB RADIOS.....	42
UPDATED 200 CHANNEL AMATEUR CONVERSION FOR 858 CHIP	43-48
10 METER CONVERSION FOR SSB RADIOS USING MB8719....	49-50
HOW TO MAKE YOUR 858 CHASSIS SLIDE.....	56
LINEAR AMPLIFIER NOTES.....	57
RECEIVE AMP - SILTRONIX.....	58-59
ECHO BOX SPEECH PROCESSING FOR TRC-449.....	60
ADDING PING.....	61
CORRECTION TO THUMBWHEEL 200 CHANNEL CONVERSION....	62-63
MICROMONITOR TECH NOTES.....	64-69
MICROMONITOR INSTALLATION for RADIOS USING 858.....	70-71
AMP FOR RF PROBE.....	72
OSCILLOSCOPE MOD. FOR RF & MODULATION DISPLAY....	73
THE "BANDIT" ANTENNA.....	74-76
SECRET CB'S OWN "TROUBLESHOOTER".....	77

VOLUME 8

	PAGE #
WHAT'S NEW ON THE ELECTRONICS HORIZON?.....	1-6
UHF FM CB (GMRS).....	7-10
UNIDEN MB8719 PLL CHIP FREQUENCY CONVERSION.....	15
FREQUENCY MOD. FOR J.C. PENNEY, COLT, LAFAYETTE, HYGAIN, ETC.....	18
BROWNING MARK IVA MOD. & UFO INSTALLATION.....	22-23
BROWNING MARK IV TRANSMITTER TROUBLESHOOTING.....	25-32
OOPS! WE GOOFED!	
VOL. 5, PAGES 31, 32, 33, 34.....	41
VOL. 7, PAGES 31, 37.....	42-43

LINEAR AMPLIFIER NOTES:
 INSTALLING & TROUBLESHOOTING LINEAR AMPS..... 47-49
 10 METER AMP BOARD MOD. TO UPRIGHT DRIVER..... 50
 YOU CAN BUILD IT:
 TWO-TONE GENERATOR..... 51
 YAESU 601 (B) FREQ. COUNTER MOD. TO READ
 CB LOW, MIDDLE, HIGH FREQ..... 52-54
 RF TEST METER..... 56-57
 REDCO UFO MODIFICATION (FROM 20 to 29.995 MHz).... 55
 SECRET CB'S POWER VECTORING..... 58
 HOW THE ECHO BOX CAN ACTUALLY SURPASS THE POWER
 OF A LINEAR IN SSB..... 59
 MICROMONITOR QUESTIONS..... 60-62
 MICROMONITOR INSTALLATION INSTRUCTIONS:
 SM5104 PLL..... 63-64
 ICOM 22S..... 65-67
 NEW PRODUCT RELEASE:
 ZAPPER 9000 MOD. & REFERENCE CHART..... 68-69
 REDCO DIGI-SCAN UFO ELITE..... 70
 CHOPPER CHARLIE ANTENNA, MODEL 64#5..... 71
 TROUBLESHOOTER..... 73
 AMATEUR VSB-1 (VOICE SIGNAL BOOSTER)..... 82

VOLUME 9

SSB'ER LOSE OUT AGAIN..... 1
 FCC ANNOUNCES PLANS FOR SIDEBAND..... 2-3
 FCC DELAYS NPRM: SSB FREQS. DOUBTFUL..... 3-4
 SPEED-O-MATIC "SPEEDO-1" X-BAND RADAR GUN..... 5-6
 CONVERSION TIPS FOR ALL SSB RADIOS..... 7
 RELAY CRYSTAL SWITCHING..... 25-26
 LETTER FROM A FRIEND..... 27-28
 HINTS & KINKS-ELECTRONIC CRYSTAL SWITCHING..... 29
 OOPS! WE GOOFED! VOL. 8, PAGE 17..... 29
 SOLVING T.V.I..... 40-42
 RADACRUZ..... 42
 IMPORTANT FACTS ABOUT ECHO BOXES..... 43-44
 OOPS! WE GOOFED! VOL. 4, PAGE 51..... 44
 VOICE SIGNAL BOOSTER (VSB-1) INSTALLATION..... 45-48
 POWER SUPPLY MODIFICATION FOR REALISTIC PRE-AMP
 NOISE-CANCELLING MIKE #21-1175..... 49-50
 HINTS & KINKS - SWITCHABLE MODULATION INCREASE..... 51
 RF ATTENUATOR..... 52-54
 PRESIDENT SERVICE BULLETINS..... 55-61
 INDEX VOLUMES 1 THRU 8..... 62-70

VOLUME 10

SECRET CB TROUBLESHOOTER..... 2-4
 VOICE SIGNAL BOOSTER - VSB-1..... 5-19
 REPLACING MB8734 with MB8719..... 35
 uPD2816C PLL PIN OUT..... 42
 TECH TIPS ON 858..... 55
 UNCONVERTIBLE CHIP LIST..... 66
 LINEAR SUGGESTIONS..... 68-69
 ZAPPER 9000 INSTALLATION HINTS..... 70
 OOPS! WE GOOFED!
 VOL. 3, PAGE 33..... 71
 VOL. 5, PAGE 24, 28, 48..... 72
 VOL. 8, PAGE 16, 17..... 72-73
 VOL. 9, PAGE 9, 51..... 74-75
 VOL. 9, PAGE 29..... 72
 CB PARABOLIC TYPE ANTENNA..... 77

VOLUME 11

CPI ALC MODIFICATION FOR INCREASED SSB POWER..... 9
 HOW TO ADD RF GAIN CONTROL TO A CPI 300/400..... 11
 VSB-1 UPDATE..... 25-26
 NEW FRONTIER: FM CB..... 27-29
 NEW PRODUCT: DIGI-SCAN DS-400..... 30-31

COMING ATTRACTIONS - SERIAL DATA/PLL
 FREQUENCY SYNTHESIZERS..... 32
 UNCONVERTIBLE AT THIS TIME -GE 3-5900A TC9101P.... 33
 ADD CH. 9 & 19AT TO COLT 210..... 33
 ZAPPER 9000 INSTALLATION UPDATES..... 34
 RADIO MODULATION ADJUSTMENTS FOR VARIOUS MODELS... 51-53
 HINTS ON SERVICING..... 54
 SERVICE NOTES-GOLDEN EAGLE MARK IV TRANSMITTER.... 55
 D104 & D104M6 ASTATIC MIKE MODIFICATION..... 55
 HOW TO SOLVE NOISE PROBLEMS..... 56-57
 MORE ON THE "TROUBLESHOOTER"..... 57
 NOISE IN DIESEL TRUCKS..... 58
 IN HOUSE VALUE LISTING..... 59
 TRUCKERS SPECIAL POLARITY PROTECTOR WITH SMARTS... 60
 HOW TO BUILD:
 LOW PASS FILTER..... 61
 20dB ATTENUATION PAD..... 61
 BALUN COIL..... 62
 1000Hz TONE..... 63
 ADD A SECOND BATTERY..... 64
 20 AMP POWER SUPPLY..... 65
 SIGNAL INJECTOR..... 66
 CMOS LOGIC PROBE..... 67
 REFERENCE OSC-DIVIDER..... 68
 READOUT MODIFICATION..... 69
 ASTATIC MIC MOD..... 70
 BILATERAL SWITCH..... 71
 PLL PINOUT DIAGRAMS..... 72-77
 THE "BANDIT" ANTENNA..... 53
 OOPS! WE GOOFED!
 VOL. 3, PAGE 25..... 78
 VOL. 6, PAGE 32..... 78
 VOL. 7, PAGE 43, 53, 63..... 78
 VOL. 8, PAGE 52..... 78
 VOL. 10, PAGE 2..... 78

VOLUME 12

SIMPLE CURE FOR RX-TX TRACKING PROBLEMS..... 21
 HAM RADIO CRYSTAL SELECTOR GUIDE..... 24
 VSB-1 HOOK-UP:
 TEABERRY STALKER XX..... 25
 REALISTIC TRC-490..... 25
 WARDS GEN-719A..... 25
 MODULATION ADJUSTMENTS FOR VARIOUS REALISTICS.... 33
 ZAPPER 9000 REDERENCE CHART..... 46
 ZAPPER TROUBLESHOOTING HINTS..... 47-48
 TC9106 PLL OPERATION ANALYSIS..... 50-53
 THE "SPREAD EAGLE" ANTENNA BREAK-THRU FOR TRUCKERS. 54-55
 BASIC PLL..... 56
 ELECTRONIC TERMINOLOGY..... 57
 SCANNER PROGRAMMING TIPS..... 58
 INTO THE KNOW WITH JAPANESE SEMICONDUCTORS..... 59
 TRANSISTOR SPECIFICATIONS..... 60
 RESISTOR COLOR GUIDE..... 61-62
 CAPACITOR CODES..... 62
 YOU CAN BUILD IT:
 "SECRET CB's" SUPER-DUPER POWER
 SUPPLY CONTROLLER..... 63
 AUDIO TEST STATION..... 64
 POWER LINE FILTER - T.V.I. FILTER..... 65
 OOPS! WE GOOFED!
 VOL. 4, PAGE 38..... 66
 VOL. 10, PAGE 10, 16, 28..... 66
 VOL. 11, PAGE 3, 10, 15, 16, 71..... 66
 INDEX VOLUMES 1 THRU 11..... 67-78

VOLUME 13

PAGE #

INTRODUCING THE SOMMERKAMP TS-788DX..... 4-9

MB8719 PINOUT..... 32

AGC SELECTOR SWITCH..... 38

CYBERNET 02A CHASSIS..... 39

HOW TO HOOK UP A 10 TURN POT TO 2000 GTL..... 40

2824C OPERATION ANALYSIS..... 41-43

VSB-1 HOOK-UP: TRC-448 & MIDLAND 77-0004 4001.... 43-44

TROUBLESHOOTING CLARIFIER PROBLEMS ON THE 858..... 45-47

SUPER REGULATOR..... 48

BUILD A RECEIVER PREAMP..... 49

LINEAR NOTES..... 50-51

MODULATED GUNN OSCILLATOR..... 52-56

CYBERNET 02A AM POWER INCREASE..... 59

REALISTIC DX300 (20-204)..... 64

BEARCAT 250..... 65

OOPS! WE GOOFED!

 VOL. 4, PAGE 39..... 66

 VOL. 6, PAGE 3 & 12..... 66

 VOL. 7, PAGE 54..... 66

 VOL. 10, PAGE 25 & 48..... 66-67

 VOL. 11, PAGE 4, 6, 10, 41, 75..... 67

INDEX VOLUMES 1 THRU 12..... 68-80

VOLUME 14

PAGE #

MB8719/11.3258 TRUTH TABLE..... 15-17

NEW PRODUCT: FM-30B THRU-LINE FREQ. COUNTER..... 18-19

NEW! "KIT A" FOR LC7130/7131 & TC9106P

 CHIPS & INSTALLATION ISNTRUCTIONS..... 20-40

 BROWNING PING INFORMATION..... 41

 25-29 MHz FREQUENCY ASSIGNMENTS..... 62-63

 ELECTRONIC TERMINOLOGY..... 63

 YOU CAN BUILD IT!

 FET RECEIVER PRE-AMP..... 64

 BUILD YOUR OWN SPACE SOUND..... 65

 BUILD AN AMPLIFIER..... 66-67

INDEX FOR VOLUMES 1 THRU 13..... 68-80

NOTES