

CIB

AN ARGUS SPECIALIST PUBLICATION

CITIZENS' BAND

FOR BRITAIN'S 250,000 CBUSERS

BACK TO BASE

Satcom Scan 4000
reviewed



Amazing New
Breakthrough

THE EQUALIZER
DIY eq project

MODUS OPERANDI
FM, AM and SSB discussed



(see inside)

Latest equipment, clubs and QSL news

maxon

ADVANCING THE ART OF
COMMUNICATION

MX 1000

CEPT TYPE APPROVED. COMPACT DESIGN.
NIGHT ILLUMINATION. LAST CHANNEL
MEMORY RETENTION. SCANNING MIKE
(OPTIONAL). SPECIAL FEATURES ON REAR
PANEL INCLUDE: 2.5mm 'S' METER JACK, 3.5mm
PA SPEAKER JACK & 3.5mm EXTERNAL
SPEAKER JACK. LED S/RF METER.
VOLUME CONTROL INCLUDES
POWER ON/OFF. SQUELCH
CONTROL WITH PA



MX 2000
AWAITING
TYPE
APPROVAL.
SPECIAL
FEATURES AS
MX 1000, PLUS:
INSTANT CHANNEL 9
SWITCH. SCANNING
SWITCH. CB/PA SWITCH.
LO/DX PUSH SWITCH

IMPORTED & DISTRIBUTED IN THE UK BY
SHARMAN'S WHOLESALE

3 BURY NEW ROAD, MANCHESTER M8 8FW

TEL: 061-834 9571 TELEX: 665446 Sharma G FAX: 061 835 3679



CB

CITIZENS' BAND

CONTENTS



Update

The latest in the fascinating world of CB. 4

Back Chat

Your very own soapbox for your thoughts and opinions. 6

Q&A

Your problems, glitches etc. solved – as best we can. 8

The Equalizer

Improve your modulation with this DIY project. 10

QSL

To misquote Bessie Smith, "Every day the postman brings good news". 17

Back to Base

A look at a brand new base station. 24

CB Bench

Another weary day in the life of our hard-working rig-doctors. 28

Modus Operandi

AM, FM, SSB – all explained here. 31

Over the Air

Shepherd Man keeps us in touch with charity events throughout the UK. 32

Question Time

Contrary to popular opinion, the DTI *do* listen. 42

Editor Eamonn Percival
 Group Editor Chris Adam Smith
 Ad Manager Cass Gilroy
 Copy Control Alistair Carnell
 Design Heather Hopkinson

Citizens' Band Magazine A SP Ltd, 1 Golden Square, London W1R 3AB.
 Telephone 01-437 0626 Typesetting by Multiform Photosetting Ltd., PO
 Box 88, University Place, Splott, Cardiff Tel: (0222) 462320.
 Printed by Chesham Press Ltd, 16-18 Germam Street, Chesham, Bucks. HP5
 1LH. UK newstrade distribution by SM Distribution Ltd., 6 Leigham-Court
 Road, Streatham, London SW16 2PG. Telephone 01-677 8111.

Overseas sales and non newstrade sales by Magazine Sales Department, No.
 1 Golden Square, London W1R 3AB. Tel 01-437 0626

Subscription Department: Intonet Ltd, 5 River Park Estate, Berkhamsted, Herts
 HP4 1HL. Tel 0442 76561-4. USA Subscription Agent: Wise Owl Worldwide
 Publications, 4314 West 238th Street, TORRANCE, CA90505, U.S.A.

UPDATE



Editorial

Spring is here, the grass is rising, I wonder where the wallies is? It is just me, or has anyone else noticed the decline in the number of bucketmouths, mike-keyers, DJs and the like of late? This can only be good for CB in general and I,

personally, am hoping that it is a good omen for the future of our hobby.

Changing the subject, bearing in mind the recent tales of distress, suicide bids and financial horror stories about the profligate 0898 telephone chat-lines (you know the ones - "Speak to Saucy Cindy about her stripping exploits" and you get a full description of how she goes about stripping wallpaper from the walls of her flat), would it not be sensible to consider citizens' band radio as an ideal alternative?

For as little as around £50 (plus £12 per annum licence fee, naturally!), anyone can obtain and operate a CB radio and converse with friends and strangers alike. Think about it, kids.

Camon Brival

Cirkit Tunes Up

A new Larsholt range of FM-receiver tuner sets, in stereo and mono versions, featuring an on-board audio amplifier is now available through the Danish company's exclusive UK distributor, Cirkit Distribution Ltd.

Especially suitable for applications in sound distribution systems, the three models all feature TDA1062-based front end, which combines good sensitivity with excellent large signal handling, a frequency range of 87.5 - 108MHz, AM suppression of 50dB and image rejection of 70dB. Other advanced features include varicap tuning, AFC amplification and control, tuning and signal level meter, noise and deviation muting and oscillator output. The 7256 is supplied in stereo or mono versions with the 7260 having an on-board audio amplifier, capable of delivering up to 6W in to 4 Ohms with a signal-to-noise ratio of greater than 90dB. The unit only requires the addition of a few external components and a loudspeaker to make a complete FM receiver.

Diode-tuned and equipped with oscillator tap to make PLL synthesis and digital

display possible, the 7256 and 7260 are only half Euro-card size, with dimensions of 100mm x 80mm and a maximum height of 25mm. Connection is via a 15-pin edge connector with 2.5mm spaced pins.

Larsholt plan to extend the series in the near future with the addition of a stereo version with audio amplifier and a control unit for PLL-synthesis.

For further information contact: Cirkit Distribution Ltd, Park Lane, Broxbourne, Hertfordshire, EN10 7NQ. Tel: (0992) 444111.

MSGB's Agree

It makes a change, these days, for CB organisations to agree on something! So, it is with great pleasure that we can reveal that Monitoring Service Great Britain Ltd and Monitoring Service of Great Britain (Voluntary Organisation) recently announced that they have reached a mutually acceptable agreement, giving both organisations sole rights, ownership and use of their logo.

This particular 'feud' has long been running but both parties have decided that the agreement can only be good for CB as a whole and channel 9 in particular.

A Case for Concern

Monitoring Service of Great Britain (Voluntary Organisation) recently released the following press notice:

In view of the success of the joint M.S.G.B. & SACBC SSB Proposal & Discussion document, we have decided

to join forces again to produce a document entitled "A CASE FOR CONCERN" which is aimed towards making a case for the needs of users in respect of UK FM 27/81 (MPT 1320). This document will show that users do not want to lose this system in the future, even

after 1992 (or 1994?) and explore the many reasons why it should be retained including the needs of our specialist users (blind, disabled and handicapped).

The document will need the views of users throughout the UK and all information should be sent to: MSGB, School

House, Meadway School, Littleton Street, London SW18 3SZ or SACBC, PO Box 1, Glasgow G69 6EF.

They should be sent before the end of March 1989. All ideas and views are welcome either as individual users or on behalf of a Club, Group or Organisation.

Amazing New Breakthrough

Just when you thought it was to time to throw your antenna into the trashcan, Pama & Co have made a revolutionary breakthrough. And here it is awaiting your approval.

Pama SWR Spray has taken years of probing, testing and working around the clock in their secret laboratories.

Not only does the Pama Spray reduce your SWR by a high percentage with each application, it wipes out any of your TVI nightmares. No more nagging neighbours, no more

endless SWRirig.

Just spray your nightmares away with Pama's SWR Spray. All you need to do is to assist Pama in their field-study by popping along to your local Pama stockist and have them treat your antenna - base or mobile - free of charge. Then phone or call in with your report to your local stockist and they will pass your comments on to Pama & Co.

Be there before noon on the first day of this month and help Pama solve the crimes of the century - TVI and SWR.

Children In Need Appeal

We recently received the following message from the Merseydee Breakers (PO Box 24, Birkenhead, Merseyside, L42 9GE):

"On behalf of the club may I take this opportunity to thank you and your magazine for the support shown towards our efforts in raising donations for this years appeal."

Several stations throughout the 75-hour "marathon" asked if we were "that club in the magazine?" so I guess it really does pay "to advertise".

Enclosed is a one of the "4-part Pudsey Bear cards" we had printed for the appeal by Des Currie which I hope you will accept as a small token of our appreciation. May I just point out that it is 1 of only 50 in A4 format from a total of 1,250 - all the rest are in the 4 part format."



four part card : 1.

four part card : 4.

ML 01, Merseydee Breakers

MIKE LIMA 24 'LES' ALLEY CAT

MIKE LIMA 06 'ROB' GENTLE GIANT

MIKE LIMA 16 'STEVE' CRUSADER



WITH
THE MIKE LIMA'S
- Merseydee - Breakers -

four part card : 2.

© BBC 1986.

four part card : 3

Frequency Allocation Chart

The radio frequency bands allocated to commercial and industrial uses in the UK can be seen at a glance on a colour-coded bar chart prepared by the DTI's Radiocommunications Division and published recently by HMSO.

Frequencies from 1 KHz up to 60 GHz are covered by the

chart which is divided into primary and secondary uses.

The main uses shown are broadcasting, fixed services, mobile, amateur, meteorological, radio location, navigation, astronomy, space, and the various maritime, aeronautical and satellite bands.

"Unified Kingdom Radio Frequency Allocations Chart" is published by HMSO, ISBN 0 11 514637 7, price £2.50.

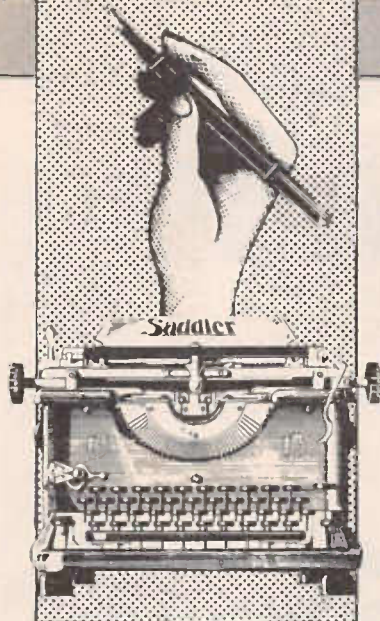

DTI REPLY

You're Nicked

Keith Townsend wrote an article in the December issue of the magazine under this heading. I thought I would attempt to try and put the record straight.

The Wireless Telegraphy (Citizens' Band and Amateur Apparatus) (Various Provisions) Order 1988 (OK, so it is a mouthfull!) came into force on 8 August 1988. Its anticipated arrival has been the subject of comment going back several years, as reported in CB Magazine. So it is hardly a surprise to the trade.

When it became more imminent we wrote in May to all the major CB radio user groups. As a result of these letters some dealers did contact us and they were also told that the Order was expected to come into force in June or July. The fact that it slipped back to 8 August gave the trade further time to prepare themselves. Once the precise timing of the Order was known, Mr Butcher, the then Parliamentary Under Secretary for Industry, made an announcement in Parliament on 20 July and the Department issued a Press Release.

In view of what I have said about the open advance publicity the Department gave to the introduction of the Order and its long discussion period I hope you will agree there was nothing low key about its introduction. It is also clear from the comments made by the dealers Keith Townsend spoke to that they were aware in the past that while it was not illegal for them to sell certain CB apparatus it was most certainly an offence for the customer to use it.

Of course, it is often a distressing experience for those who find themselves on the wrong side of the law and therefore the subject of enforcement action. However, I hope you would agree a major concern must always be for people like Keith describes as "Johnny who has just bought his first rig and didn't know it wasn't covered by his licence until the RIS came round".

I noticed that the sentiments expressed by Keith in his article were in direct contrast with those expressed by Shepherd Man in the same issue. He thought the Order was 'long overdue'.

You can't please all of the people all of the time!

**B A Maxwell,
Director,
Radio Investigation Service,
Department of Trade and Industry**

*Keith Townsend replies:
Like Shepherd Man, I welcome the introduction of the Order which finally removes a long-standing anomaly whereby CBers could legally buy something which they could not legally use. In fact, as Mr Maxwell well knows, I have been clamouring for just such a prohibition as this Order encompasses for at least two years prior to its introduction. This, together with the fact that I still have not seen a copy of the Press Release which preceded its introduction, leaves me all the more curious that I, together with many dealers, should have been taken by surprise by the timing of its introduction.*

Mobile Medico 9

After the first successful year of going mobile, Medico 9 would like to ask that, if any clubs or organisations are putting on or are thinking of putting an Eyeball or similar event this year and would like

First Aid coverage, would they get in touch with us as soon as possible as dates are being booked up very quickly.

As a Charity Voluntary Organisation, all expenses are met by the members, so all we ask for this coverage is a little

help with our petrol costs. We are willing to travel anywhere in the country.

Events already book with us to cover are: Horseshoe Pass; Caerphilly; Cheltenham; Ladram Bay, Devon; Coventry; Worthing; Rousden, Devon; Chasewater; Longleat; Gloucester; Bodelwyddan; Warwick and the Sunrisers, Burnham-on-Sea.

So, if you wish our services for your event, please contact us at the address below.

**Medico 9 Organisation,
Mr. M Potter A.F.I.C.D. (Medico 29),
67 Garway Close,
Redditch,
Worcestershire**



EINSTEIN DX GROUP

"ESTAMOS EN EL AIRE"



Spanish Situation

First of all let us introduce ourselves as CB users of Spain, and as the President of the international group "THE EINSTEIN DX GROUP", Francisco, and the Secretary of the international group "ANTEQUERA QSL DX SWAP CLUB", Manolo, both groups from Spain, but with members worldwide.

We know about your well-known magazine since some years ago, and we have talked to each other to write this letter about the Spanish CB scene, and send it afterwards to you, so please consider its publication or at least a mention of this information and situation.

Since the legal CB came to Spain, the channels are not as full of people as they used to be 5 or 6 years ago. Nowadays, in little towns you can find only a couple of channels occupied, so there is not a lot of QSO to be chosen. We think it is because most of the people who used to talk on this frequency do not agree at all with the legal situation, as they find it very strict and very hard. Most of the people who have bought a legal rig and a legal licence is because they are afraid of being fined, but not more than 5% like this situation.

People cannot buy multimodes anymore and people who have old multimodes or AM rigs have to keep them, as they are not allowed to be used or to be sold either. Anyway, people still use SSB and AM modes as the Government is not as strict or hard as it is in other countries.

About the legal situation, there are about 14 rigs which are legal, with a legal licence, of course. The prices of these rigs are between 60 and 100 English pounds, and the annual fee of the licence is about 10 English pounds, though the first year is a little bit more expensive, 27 pounds. You do not need any examination at all, and anyone can get a licence just being over 15 years old.

As in 1992 it's going to be the real union of the European countries; it's obvious that we all should have the same legal situation, but we think that it should be a little more sensible, maybe with AM and SSB legalized, and 80 channels, as it is in some "developed countries".

About magazines, there has been a complete disaster in Spain in the last years, different magazines with different names but always with the same leaders have been earning and getting subscriptions and then they have disappeared, no magazines and no money anymore. Nowadays, CORREO CB, (CB Mail), is the only one we have in Spain. It seems much more serious

NAME:
UNIT: AN

EIGHTH OFFICIAL CLUB CARD

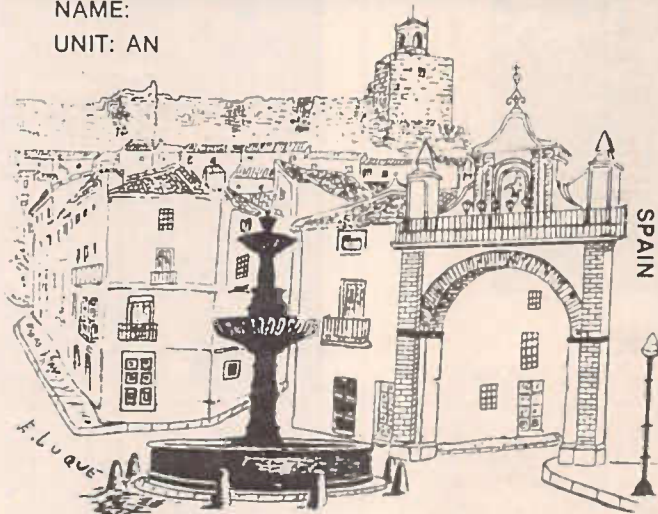

SAN SEBASTIAN SQUARE - ANTEQUERA

ANTEQUERA QSL DX SWAP CLUB
P.O. BOX 92
29200 ANTEQUERA (MALAGA)
SPAIN

than the old ones, is lead by a young crew who are getting a lot of readers. This magazine, in fact, looks like a newspaper, is sent free to all legal operators. It has about 30,000 readers, and is now one year and two months old. It has a lot of advertisements, as I suppose it is the way they get money to produce the magazine.

There are a lot of local groups organizing fox-hunts, 24-hour modulations, meetings and so on, but there are only a few good international groups, like THE EINSTEIN DX GROUP and the ANTEQUERA QSL DX GROUP, who are very well known worldwide, and

are thinking of printing a special QSL for the Olympic Games to be held in Barcelona, Spain, in 1992. This QSL will be printed probably as a Currie collector series, maybe full-color, so they will be available to all QSL collectors.

Well, that's all for now, enclosed you will find our groups' QSL's just in case you want to reproduce them. Thank you very much indeed for your attention, and please do consider the inclusion of this article in your magazine.

Francis Garcia,
P.O. Box 859,
46080 Valencia,
Spain

Don't Push It

On Wednesday 25th January, my mobile DX station was closed down by the DTI. The reason was because I was using a 40 - 80 watt linear, which amplified the harmonics produced by my rig, a Uniden 400, causing interference to the Fire Service emergency frequencies.

I doubt I need to dwell on the point of this letter, only to say I was shocked into a state from which I have still yet to recover, to think that by using a little

power to push my signal, I had unknowingly caused problems to an emergency service 45 miles away. The experience of being closed down by the DTI is unpleasant enough but to know that by pushing power we can hinder the emergency services is horrifying.

My message is clear - don't push power; it could be your family that needs the emergency services.
Robin,
Warwick



Dish Of Delights

Dish of Delights

Q This may be a silly question, but I'll ask it anyway. I've recently purchased a satellite TV system. It occurred to me that the dish antenna must have a good gain figure, and will also be extremely directional. What would happen if I fed my homebase CB rig to the dish – would it increase range – albeit in one direction only, or would it be a waste of time? If it worked I could mount a second dish, and use it to link my house with my office, which is nine miles away – the narrow beam produced by the dishes would make the signal secure from interference. What do you think?

Steve Gann
Middlesbrough

A An interesting idea, unfortunately it wouldn't work. The problem is one of frequency – TV satellites operate at microwave frequencies, on what is known as the KU band, that's around 10-12 gigahertz, or 10,000-12,000 megahertz! A typical satellite dish is not much larger than a dustbin lid, at CB frequencies it would have no effect whatsoever, either in terms of gain or directionally, even if you could devise a method of radiating the RF energy at its focal point – which is next to impossible anyway . . . In short don't be tempted to connect these two technologies together – you could damage the extremely sensitive and rather expensive LNB (low noise block converter) mounted on the dish.



Mini-Beam Muddle

Q Help! I have made myself a mini-beam from DV27's – don't laugh too much . . . However, I appear to have a propagation problem – my best propagation appears to be 90 degrees to the right of where it should be! Have you got any ideas as to the cause, and the cure? The six DV's are attached to a central boom in three pairs, the driven element is one of the central pair, all of the other directors and reflectors are insulated from the boom. The directors have been shortened, and the directors extended by 9/10 inch. It stands approximately 30 feet off the ground and is rotated by hand.

Guy Hageman
Bridlington

A You're in uncharted waters here – your theory seems sound enough, from the diagram supplied, but until someone comes along who has used this configuration successfully we're not able to say precisely what has gone wrong. The only thing we can think of is an insulation problem between the driven element and the supporting pole – this would conceivably produce the radiation pattern you show, on such a set up. Has anyone else tried this type of arrangement – we'd be interested to hear of your experiences.

Crystal Confusion

Q I recently obtained a 'Great GT-417FM' hand-held CB, which is designed for 6-channel operation - 27.60125MHz.

The crystals used are 27.146245MHz for Tx, and 13.802125 for Rx. I have calculated that for Tx crystals you add 455kHz to the channel frequency, but can you tell me how to calculate the value of the Rx crystals. Can you also suggest where I can obtain suitable crystals for this rig?

M. Miller
Brentwood
Essex

A Welcome to the minefield! You've correctly established the relationships of transmitter crystals to transmitter frequency - the difference of 455 kHz is known as the IF or intermediate frequency. This is a fairly standard value and varies little between manufacturers. The value of the Rx crystal is another matter - here the relationships can be more obscure - it could be one quarter or one eighth of the nominal transmit frequency, or even related to an overtone or harmonic produced by the crystal. In your case it looks suspiciously like one half of the transmit frequency, although your calculator will tell you it's not quite the same value. It could be that the manufacturers use the nearest off-the-shelf component, and use a simple circuitry to 'pull' the crystal on to its operating frequency. That's the easy bit - the difficult part is getting hold of extra crystals. They used to be fairly common but these days relatively few rigs use multiple plug-in crystals. The other problem is the large number of different types and sizes used - we know of at least a dozen different pin configurations. Now the good news - we know a man who can help. He's Dave Collins. He'll need to know things like the size and shape of your crystals and the distance between the pins. He should be able to work out the frequencies for you given the information you've given us. Contact him at **QuartSLab Marketing Ltd., PO Box 19, Erith, Kent DA8 1LH. 01-318 4419.**

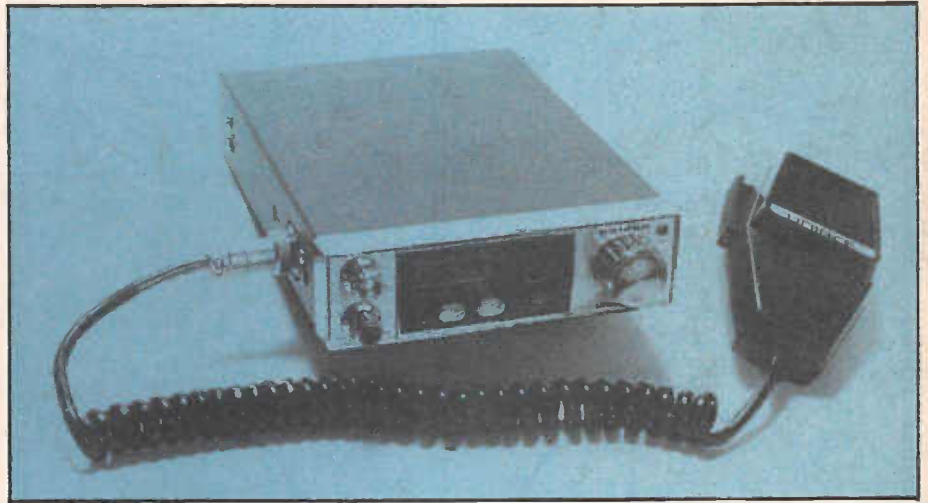

Number Crunched

Q My Uniden 2000 rig has developed an odd fault - the digital display gradually fades out over a period of about 15 minutes. If I switch the rig off, and allow it to cool down it will reappear. I suspect the display is getting overheated - is there anything I can do, or will it need replacing?

H. Freeman
Bristol

A It's highly unlikely that it's the actual display device - they're composed of independent light-emitting elements. It's not unknown for individual elements to fail, but hard to see how they can all develop the same fault at once. You don't say if the rest of the rig is still working, when the display goes off - if it does then the fault is almost certainly centred on the display driver circuitry. If the whole rig shuts down then there's a thermal fault, probably on the voltage regulator chip. In either case any rig-doctor worth their salt will track it down in a matter of minutes, armed with their trusty can of freezer aerosol . . .

DATA Dilemma

Q My friend and I both have the same Amstrad computers and other computer users via telephone modems. I would like to know if it's possible to use our CBs to link the two computers together. I would save a fortune on telephone bills - would it simply be a case of hooking the audio input from the rigs to the modem or is there more involved?

Shaun Stavely
London N17

A Sorry to disappoint you but it can't be done, at least not as far as we know. (We have to say that as there's bound to be some to be some clever Dick out there who has solved the problem . . .). The basic stumbling block is that CB is a simplex system - that is

signals can only be sent in one direction at a time. Telephones operate using a duplex system, ie simultaneous two-way traffic. This point is important - the data transmission system used by most computers relies on a two-way link, so that both machines are effectively talking to each other, in essence telling one another that each part of the message has arrived safely, and to send the next bit of information. Clearly this is impossible using CB, unless you can re-write the basic communications software - the program that controls the two computers whilst they're talking to each other. Moreover you would have to devise some way of activating the Tx/Rx circuitry on both rigs. Even if you could you would probably find that the bandwidth and noise levels of a typical CB link make reliable communications impossible, even at the very slowest speeds. By the way, if someone has come up with a way to do it, we'd like to hear from you.

These days, graphic equalisers are a common sight on even the most modest of Hi-Fi set up, and most people are aware of their effects. Used for their most basic concept, they act as a kind of super tone control. They were designed to allow the user to compensate for a room not having the ideal acoustic qualities for the proper playback of pre-recorded material. The design presented here uses the same idea to allow the CB enthusiast to compensate for a less than perfect transmitter set up.

How and Why

Any good audio circuit design would aim to provide a "flat" frequency response. That is, to provide the same amount of audio amplification no matter what the frequency of the signal that is applied to its input. Unfortunately, the rooms in which we listen to our recordings usually place an emphasis on certain frequencies within the audio spectrum. This action completely falsifies all attempts to keep the frequency response flat.

It is therefore necessary to produce a circuit which can compensate for the room's acoustic faults. Standard bass/treble controls go some way to helping the problem, but they can only affect (in broad terms) the lower and the higher frequencies. A graphic equaliser provides controls for a number of "sections" of the audio spectrum and therefore can compensate for poor acoustics far more accurately.

Of course, the world of Hi-Fi is far removed from the world of CB, but the EQ described here can still be of benefit. The audio circuits within the transmitter and microphone are by no means perfect and so the EQ will help to balance their response. The EQ can correct a hollow or muffled sounding microphone, whilst giving that extra bit of quality to the better mic's. The circuits within an EQ are quite simple, although they are easier to construct than to explain!

How it Works

As radio enthusiasts, we should already be familiar with the resonant or tuned circuit. Fig 1a shows a series tuned circuit consisting of a capacitor and an

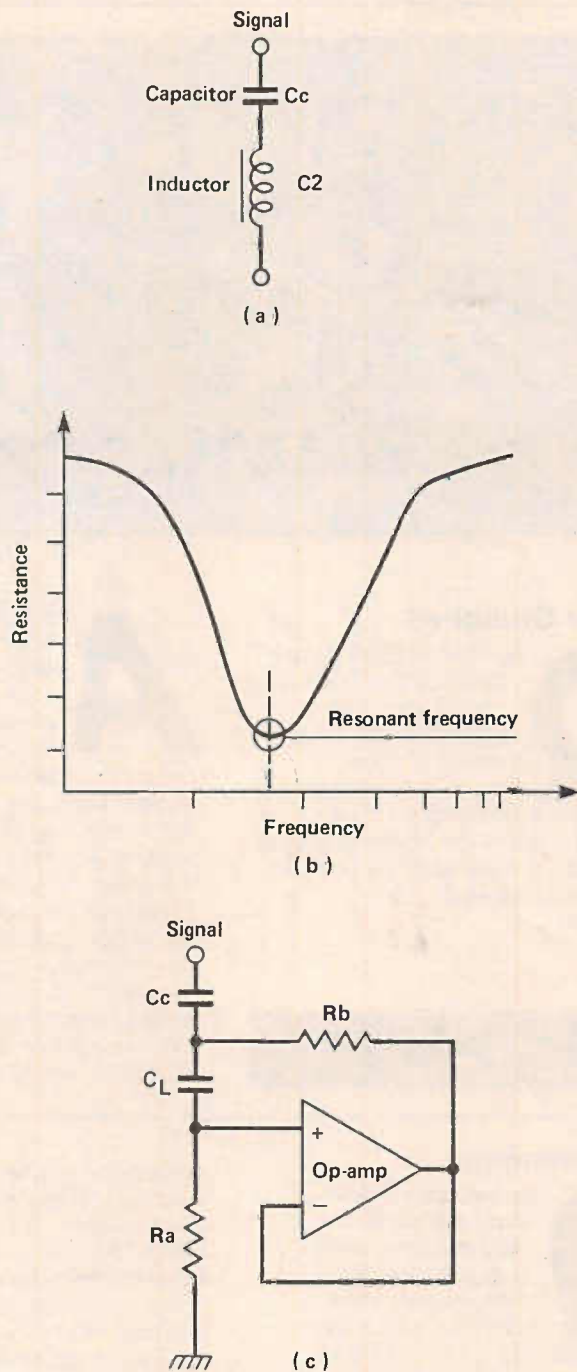

Figure 1. The gyrator is a solid state inductor

- ★Compensates for poor sounding microphones
- ★Can reduce transmitted road noise
- ★Processes voice for easy listening or DX work
- ★Low cost, easy-to-build design

THE EQUALIZER

by David Cox

inductor. The reactance or the resistance of these components changes in proportion to the frequency of the applied signal. The resistance through the capacitor decreases with increased frequency, whereas the resistance of the inductor increases with increased frequency.

When these two opposing components are placed in series, a response shown in Fig 1b is produced. Note how the resistance of the network reaches a low point at a particular frequency, whilst the resistance of the network increases on either side of this "resonant frequency."

Networks such as these are used in radios to select a particular frequency to which we wish to listen. In the case of our graphic EQ, they could also be used to select a frequency to be modified. However, this is not the case since there is a higher quality and more convenient method.

Inductors are quite simply a section of

coiled wire. The more coils that are included, the higher the inductance of the component (inductance is measured

in Henrys). They work well at radio frequencies but in a design such as this, at low frequencies higher value

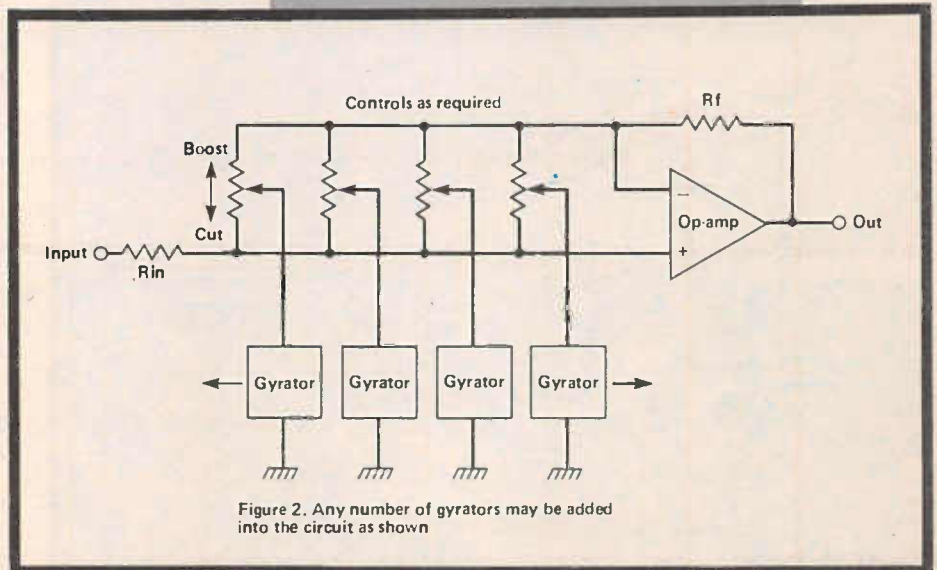

Figure 2. Any number of gyrators may be added into the circuit as shown

inductors are required. This would mean making up inductors consisting of many hundreds of coils of wire. Now though, there exists a high quality cheap and effective alternative.

Fig 1c outlines the basic circuit of the gyrator. It consists of an inverting amplifier and a capacitor. As was hinted at earlier, an inductor is almost the exact opposite of the capacitor. Therefore, the gyrator circuit simply inverts the effect of CL to forge the effect of an inductor. The capacitor Cc, is not modified and has the same effect as its counterpart in Fig 1a.

The value of inductance offered by this circuit is simply a product a Ra, Rb and CL; where the resistance is in Ohms, and the capacitance is in Farads, the inductance will be in Henrys.

As many gyrators as required may be inserted into a graphic EQ, to provide as

Effective inductance of gyrator:-

$$L = R_a R_b C_L$$

Resonant impedance of gyrator (Rg):-

$$R_g = \left(\frac{1}{2\pi F C_c} \right) + (2\pi F R_a R_b C_L)$$

Maximum band boost:-

$$\text{Boost} = 20 \text{ Log} \left(\frac{R_f + R_g}{R_g} \right) \text{ dB}$$

Maximum band cut:-

$$\text{Cut} = 20 \text{ Log} \left(\frac{R_g}{R_{in} + R_g} \right) \text{ dB}$$

Resonant Frequency:-

$$R_{FREQ} = \frac{1}{(2\pi \sqrt{R_a R_b C_c C_L})}$$

To find L and Cc for frequency:-

(Rx is half of the required gyrator resonant impedance).

$$L = \frac{R_x}{2\pi F}$$

$$C = \frac{1}{2\pi F R_x}$$

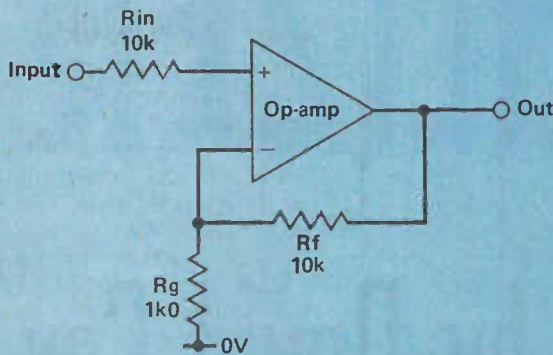

Figure 3a. EQ giving 20dB boost

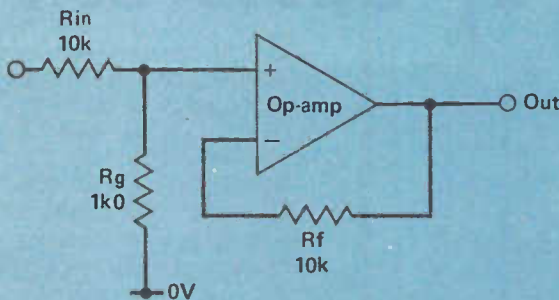

Figure 3b. 20dB cut

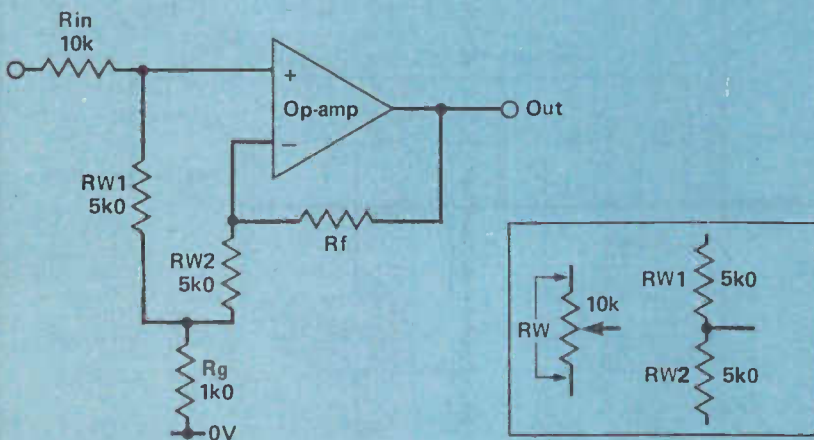

Figure 3c. 'Flat' control - No gain

many bands as needed. They are then coupled via controls into a mixer stage. A block diagram to such a circuit is detailed in Fig 2.

To understand how an EQ selects and modifies one particular frequency, it is easier to break down Fig 2 into its key components. In Fig 3, Rg is used to represent the resistance of the gyrator when at its resonant frequency. For ease of calculations, assume that Rg would be 1k Ohms at this frequency. The following diagrams show only one gyrator but the same theory would hold true for numerous bands.

Fig 3a shows the state of the mixer when a band control is moved fully to its BOOST setting. Note that the gyrator is effectively connected directly to the inverting input (-) of the op amp. Here, the op amp acts as a non inverting amplifier, with its gain set by Rf and Rg. Using the component values as specified, the gain would be 20dB.

Fig 3b shows what happens when the same control is moved fully to its CUT setting. Now, Rg is connected to the non inverting input (+) and in combination with Rin, forms a standard voltage divider. The divider here causes a loss (or cut) of 20dB. Rf has no effect and so the amplifier has no gain.

Fig 3c shows the effect of placing the band control in the middle of its range. Rw1 and Rw2 represent the two halves of the potentiometer as outlined in the inset diagram. In this case, a voltage divider is set up by Rw1 and Rg, together with Rin. This causes a reduction in signal level. However, Rg and Rw2 are also in a circuit with the amplifier and Rf. Since all resistance values are equal, the amplifier produces a gain that compensates exactly for the losses in the previous stage. Thus, no boosting or cutting takes place.

Obviously, varying the band control would provide a continuously variable amount of boost or cut. Remember that the resistance of the gyrator increases

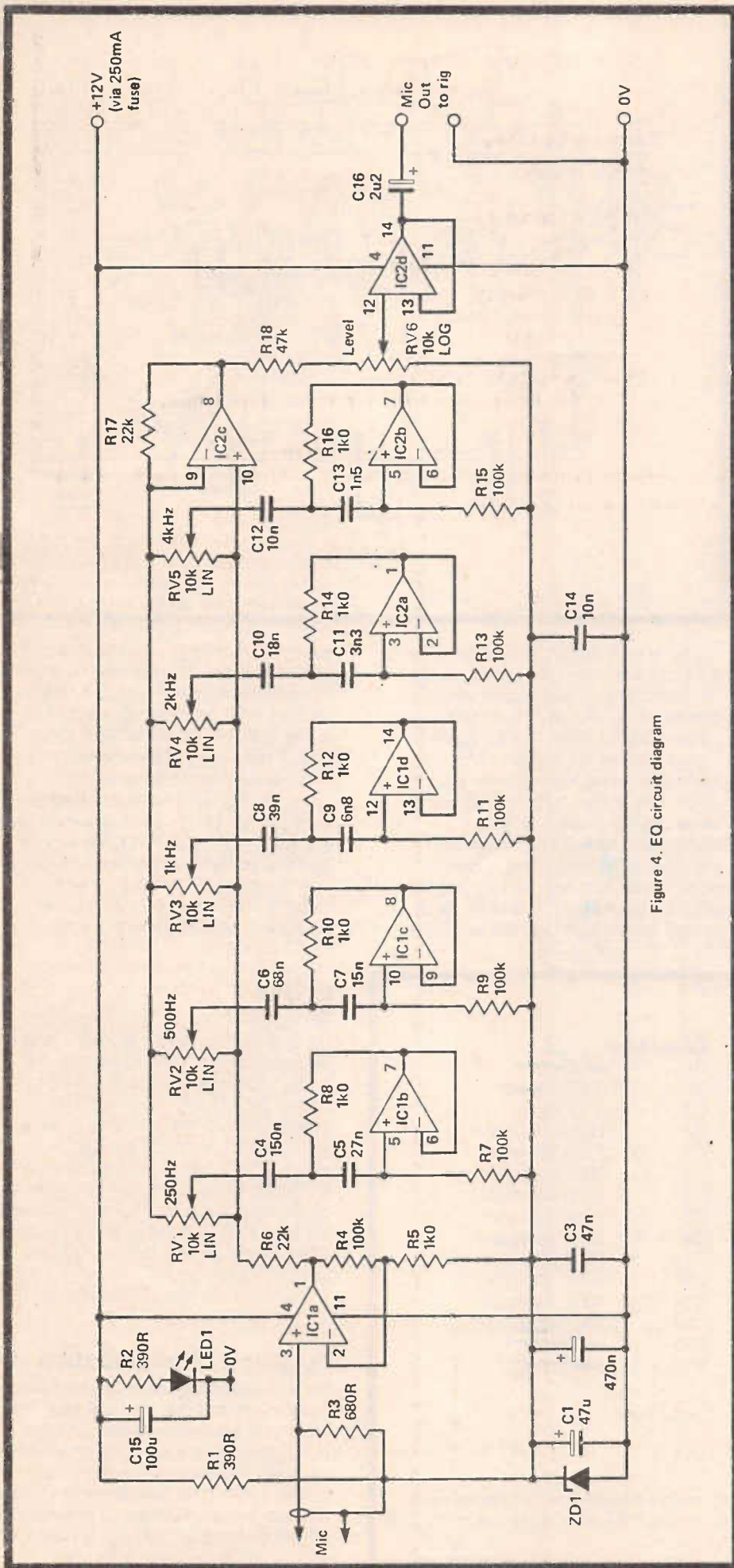

Figure 4. EQ circuit diagram

when the frequency across it differs to the gyrator's resonant frequency. Therefore, if the input frequency is not within the range of the gyrator, R_g would be a high resistance and would have little effect on the circuit.

CB-EQ Design Brief

Graphic equalisers designed for Hi-Fi, would have to deal with a frequency range extending to at least 20,000Hz. This design though, only deals with the human voice and so only needs to act on a frequency range of between 300Hz and 4000Hz. The bands selected on this graphic EQ design are set at full octave intervals as follows: 250Hz, 500Hz, 1KHz, 2KHz and 4KHz. This gives a suitable range of control for general bass, treble and "brightness" of the transmitted speech. Each band may be boosted or cut by 12dB. The design also includes a bypass switch for instant normal/processed comparisons.

Circuit in Detail

The full circuit diagram is shown in Fig 4. The unit is formed around two low cost chips (IC1 and IC2), each containing four operational amplifiers. So that the unit can work properly, a highly stable centre tap has to be taken from the main power supply. R1 and ZD1 form a stable 5 volt supply and C1, C2, C3 and C4 smooth and decouple it. Throughout the circuit, this supply is used as a reference ground. The two supply lines then become +7 volts and -5 volts with reference to this centre tap.

IC1a forms a standard non inverting amplifier with a gain of about 40dB. This boosts the incoming microphone signal to a more useful level. R3 sets a low input impedance and R4 and R5 set the gain of the input amplifier. R2 sets the current to light the LED, D1.

R6 couples the input signal to the control chain of VR1 to VR5. Each of the five gyrator circuits can be seen clearly and are constructed around IC1 parts B, C & D, and IC2 parts A and B. IC2 is the mixer stage and SW1 is the bypass switch as already described. VR6 is the sixth and final control and is used to select the output level. R18 sets the maximum level available. IC2c provides output buffering and C16 removes the 5 volt DC offset from the output signal.

Construction

Although this design is not very complicated, it would make construction difficult if the unit was not placed on a printed circuit board. The pattern for the PCB is shown in Fig 5. Carefully check the tracks on the board for cracks before proceeding.

If an equaliser was to be "graphic," it would have to use sliding band controls so that each slider knob becomes part of a response graph. For ease of

construction, this unit was designed with rotary potentiometers in mind. These are cheaper and much easier to fit. There is no electrical reason why slider pots should not be employed.

Figure 6 shows the component overlay and the wiring details. Begin by inserting the low profile components; wire links, resistors and IC sockets. Continue with the capacitors whilst constantly checking for insertion errors. Note that C1, C2, C15 and C16 will not work if placed in the wrong way around. Match the plus or minus signs on the capacitor with those on the diagram. Use the minimum of heat when soldering the zener diodes, ZD1 and the LED, D1. Both of these components must face the correct way. It is a good idea to insert 'veropins' where off board wires are to be connected. Use plenty of solder to connect up the six potentiometers. VR6 is different to the other five pots and is identified by the word 'LOG' on the back. VR1 to VR5 will have LIN written on them. Finally, insert IC1 and IC2, making sure that they are correctly positioned.

Now is a convenient time to test the board. A multimeter will be helpful if you can find one. Connect up a power supply and the LED should light. A current of less than 30mA should be drawn from the supply. If a significantly higher current is drawn, or the LED does not light, switch off and recheck.

With the meter set to read volts, with reference to the supply ground level, pin 1 of IC1 and pins 8 and 14 of IC2 should be at about 5 volts. If not, check ZD1 and associated components. On both chips, pin 4 should be at supply level (12 volts) and pin 11 should be at ground level (0 volts).

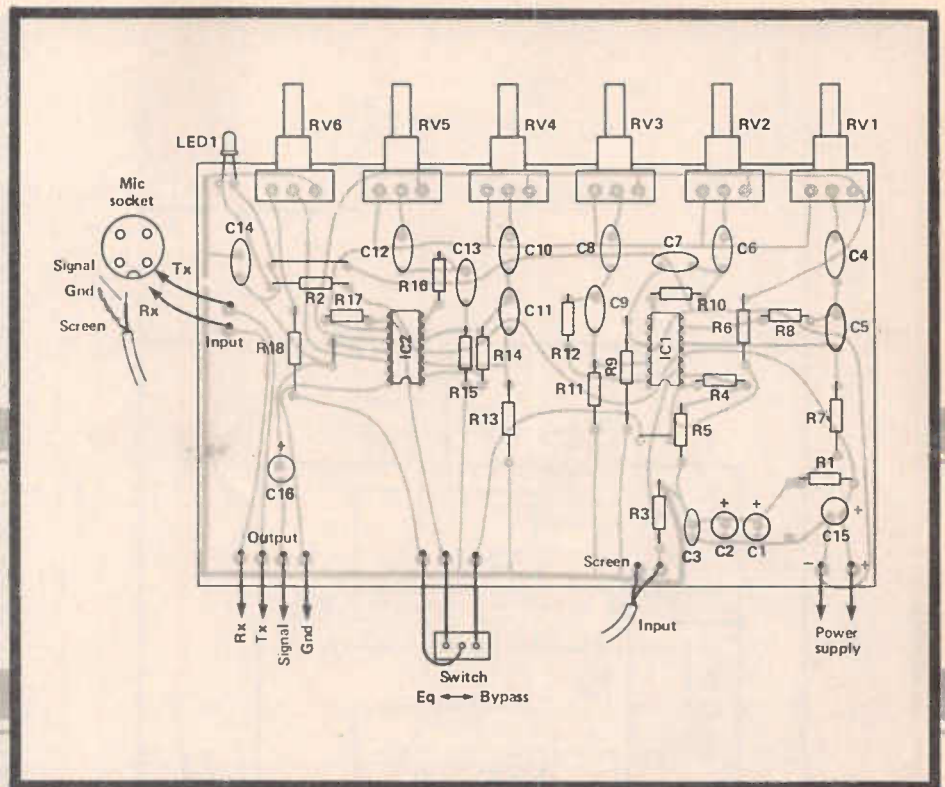

If all is well, switch off and continue to wire up as required. The wiring to the microphone plug and socket will differ from rig to rig and so should be hooked up as required. Note that the positive supply wire must carry an inline fuseholder close to the power source.

The box should be prepared with the same care and attention as the electronics (!!). Eight holes will be required in the front panel and these can be drilled as required. VR1 to VR6 will require 10mm holes, and (if the PCB is copied accurately) they will be 25mm

apart. The switch and mic* connector can be inserted at any convenient point.

The rear panel will require one hole for the power cables and one hole for the rig connection cable. Both holes should have a grommet and suitable strain relief to protect the cables.

It is always worthwhile finishing the front panel with rub-down transfers for that professional look. A good way to give the unit a thorough test is to use it with the PA setting if your rig has this function. This way, you can hear for yourself the effect the unit is having.

Components list for CB-EQ

Resistors

R1, R2 390R (2) ✓
 R3 680R ✓
 R4, R7, R9
 R11, R13, R15, 100K (6) ✓
 R5, R8, R10
 R12, R14, R16 1K (6)
 R6, R17 22K (2) ✓
 R18 47K
 VR1 to VR5
 10K linear potentiometers (5)
 VR6 10K logarithmic Pot

Semiconductors

IC1, IC2
 LM324 quad op amps (2)
 D1 5mm red LED
 ZD1 5.1 volts, 0.5 watt Zener diode

Miscellaneous

14 pin IC sockets (2), SPDT switch, PCB, Mic plug & socket, Box, screened wire, veropins, Knobs (6), PCB supports, transfers, 4 core mic cable, grommet, inline fuse holder, 250 mA fuse, solder, wire etc.

Capacitors

C1 47uF elect
 C2 0.47uF elect
 C3 47nF mylar
 C4 150nF polyester
 C5 27nF polyester
 C6 68nF polyester
 C7 15nF polyester
 C8 39nF polyester
 C9 6.8nF polyester
 C10 18nF polyester
 C11 3.3nF polyester
 C12, C14 10nF mylar (2)
 C13 1.5nF polyester
 C15 100uF elect
 C16 2.2uF elect

In Use

To begin with, set all of the frequency controls to their centre positions. Use the level control (VR6) to provide the correct output level. The only way to master the EQ is to continuously experiment with each setting. Cutting back on the low bands will help to reduce road noise in your transmissions. A muffled microphone can be corrected by boosting the higher bands. Throwing the bypass switch will allow you to make instant comparisons between normal and processed sound. Sooner or later you will find the correct settings to bring out the details of your voice.

Further Experimentation

For those who might like to look further into the applications of equalisers, the equations which are used to find the component values are printed below. In all cases, values of capacitance are inserted in Farads, resistance in Ohms and inductance in Henrys. Frequency should be inserted in Hertz. Ra, Rb, Cc and CL are as detailed in Fig 1c.



U.K.'S No. 1 TRUCK & CB STORE



Our 3rd edition catalogue is still available at £2.00 and features over 2,000 truck and CB items. The 4th edition will appear in the next few weeks. If you would like to order this now, please send £2.00 along with your details on a separate piece of paper and this will be sent on as soon as available.



Off Junction 5 M.L. 320 St. Albans Road, Watford, Herts. WD2 5PQ
TEL (0923) 35943

CREDIT CARDS AND CARRIER DELIVERY

To make your purchase fast and efficient we take Access, Visa and Amex for both phone and mail order sales. Your new radio will normally be on its way within 24 hours of receipt of order and we even have a carrier service. Just £6.00 for any parcel, within the U.K. mainland, which will ensure swift delivery (within 2 days for most regions). Just the job for those urgent requirements.

AS ONE OF THE UK'S OLDEST ESTABLISHED CB SPECIALISTS TRADING SINCE 1979 WE HAVE THE WIDEST RANGE OF CB's AND ACCESSORIES IN THE COUNTRY.

G ALL MAIL ORDER ITEMS ARE CHECKED & TESTED BEFORE DESPATCH WHEREVER POSSIBLE AND FULLY GUARANTEED.

HOME BASE ANTENNA PRICE BLITZ

- We've reduced our prices considerably on some top selling base aerials.
- THUNDERPOLE 3 (LEGAL) **£19.00** + £1.50 p&p.
 - LEMM MINI GP (LEGAL) **£18.00** + £1.50 p&p.
 - TAGRA BT — 104 SIGMA 4 **£72.00** + £3.00 p&p.
 - VIKING 777/ANTRON 99 **£55.00** + £2.00 p&p.
 - SIRIO 2012 **£70.00** + £3.00 p&p.
 - TAGRA BT 210 SIGMA 2 **£52.50** + £2.00 p&p.
 - SHAKESPEARE SUPER BIG STICK **£75.00** + £3.00 p&p.
- To comply with recent legislation we wish to point out unless a base antenna is marked legal in our advertisement it should only be used for the 10 meter amateur band frequency (28.00-29.70 MHz).

DISCOUNT PRICES on CB RADIOS



MOBILE RADIOS

- UNIDEN 200 — **£86.00** + £2.00 p&p
- MIDLAND 77-104 **£59.00** + £2.00 p&p
- MAXCOM 30E. **£79.00** + £2.00 p&p

PR 27 GB MOBILE RADIOS

- DNT. CONTACT 40 **£49.00** + £2.00 p&p
- DNT. CONTACT 40 W/SCAN MIKE **£59.00** + £2.00 p&p

PR 27 GB BASE STATIONS

- SATCOM 4000 BASE STATION **£189.00** + £3.00 p&p

HAND HELD RADIOS

- JESAN CB 950 — **£59.00** + £2.00 p&p
- MIDLAND 77-805 **£79.00** + £2.00 p&p

PR 27 GB HAND HELD RADIOS

- DNT 4000 FM **£59.00** + £2.00 p&p.

Uniden PRO 450E
 Just Type Approved for PR 27GB, features volume, squelch, mike and RF gain, PA, tone switch, LED dimmer, S. RF and Modulation meter with new style LED chain meter. A nice quality unit, offered at the UK's lowest price.
£110 + £2.00 p&p

DNT SCANNER 40
NEW PR 27 GB
 This unit has just received type approval — RTD No. 3715 — and features Volume, Squelch, Ch. 9, and 19 switch, variable power output, PA scan mike, Channel free Indicator, Noise blander and electronic scan search.
SPECIAL INTRODUCTORY PRICE £110 + £2.00 p&p

AV-801 Astro Scan Base Station

Multiply your scanner power with this patented high performance antenna. Co-Inductive 5/8 wave design for low band; full 1/2 wave dipole design for high band; and 1 1/2 wave collinear design for UHF/800 MHz. Weighs only 2.25lb. Cable not included.
£39.00 + £2.00 p&p.

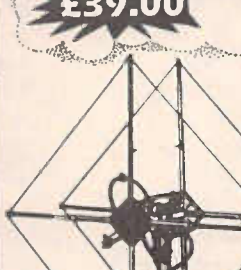

PDL 2 QUAD

Original Avanti stock purchased by us recently in the USA (repackaged by Antenna specialists) gives a shattering db gain. LIMITED QUANTITY — PLEASE RESERVE BY PHONE.
£149.00 + £3.00 p&p

AVANTI AV-140 MOONRAKER NOW IN STOCK 14.5db gain

DOWN IN PRICE! FC 250 FREQUENCY COUNTER

£45.00 + £1.00 p&p
 Covers up to 250 MHz requires 12v supply.

SOME RECENT ANTENNA IMPORTS

VAN ORDT POW-R-STIK

QUAD WOUND 4 x 7/8 WAVE!
 The ultimate helical antenna! The POW-R-STIK is 4 x 7/8 wave windings of high quality copper, rate to 1500 watts. Covers over 2MHz with SWR 1:1 to 1:1.5. Adjustable SWR tip and made from the finest materials. Copper coloured over black fibreglass.
 Try this one on your base station ground plane kit or go mobile using a strong stud fitting.
54" POW-R-STIK £23.00
66" POW-R-STIK £26.50



HUSTLER SCB

- 1000 watt capacity
- Extra wide bandwidth — 2 MHz
- High efficiency coil
- Stainless steel tip rod
- Overall height 46"
- Mounts on 3/4" x 24 mount

£26.00 + £2.00 p&p

VAN ORDT AUDIO KING AKO-100

The famous oil filled coil on the Audio King stabilizes SWR and enables use at up to 1.5kW with good bandwidth. Price includes 14" ss coil shaft, coil and whip (overall length approx 60") **£38** + £2.00 p&p



A NEW RANGE OF HIGH POWER LOW PRICE LINEARS FROM ITALY.

- LEMM LEOPARD L60 (40 watts @ 4w in) **£29.00**
- LEMM LEOPARD L200 (100 plus watts @ 5w in) **£46.00**

- LEMM LEOPARD L300 (200w @ 5w in) **£80.00**
- LEMM LEOPARD L350 (300w @ 10w in) **£110.00**

MAIL ORDER To: TRUCK KING, Dept CB4 189 320 ST. ALBANS ROAD, WATFORD WD2 5PQ

Enquiries, ACCESS · VISA · AMEX orders phone (0923) 35943

All prices quoted include post & packing. Overseas orders add 20% (£ Sterling only please)

QTY	ITEM	£

Name _____
 Address _____
 I enclose Cheque/PO. for £ _____ payable to Truck King
 I wish to pay by ACCESS VISA VISA AMERICAN EXPRESS AMEX (Tick)
 Card No. _____ 0923 35943

PLEASE USE A SEPARATE SHEET OF PAPER IF YOU NEED MORE ROOM

**Pama
& Co****FOR****WHOLESALE ONLY****Pama
& Co****THE PAMA SALES TEAM****IGAL****EDI****NEW
FREEPHONE
ORDER LINE
FOR
ORDERS
ONLY****FREEPHONE
(0800)
262963****JACK****LEN****DO THE PRODUCTS YOU STOCK SELL FAST?
Pama's Do!**

Pama realise that being a C.B. retailer is not easy, we understand your problems and how important it is that you have the products that sell on your shelves fast, thats why Pama's is probably the biggest independent C.B. wholesaler in the country.

10 GOOD REASONS FOR CALLING Pama

- ★ EXTENSIVE STOCK RANGES
- ★ DISTRIBUTOR OF ALL LEADING BRANDS
- ★ ALL ORDERS DESPATCHED WITHIN 1 HOUR OF PLACEMENT
- ★ HIGHLY COMPETITIVE PRICES
- ★ FULL SERVICE AND SALES BACK-UP
- ★ FRIENDLY - PROFESSIONAL SALES TEAM
- ★ THE FASTEST DELIVERY IN THE U.K.
- ★ EVERYTHING FROM A - Z IN C.B. IN ONE PLACE
- ★ DELIVERY EVERYWHERE NATIONWIDE & EUROPE
- ★ TRADE-ONLY, OPEN 7 DAYS A WEEK.

To set up an account with Pama is easy, just pick up the phone and call one of the sales team **ON THE HOTLINE (061-446 2437) 3 LINES AVAILABLE** and they will be pleased to answer all your questions and send any information, you require.

***WE ARE CELEBRATING 10 YEARS OF PAMA
SO THERE ARE MANY CELEBRATORY OFFERS*****PAMA HOUSE, 433 WILMSLOW ROAD,
WITHINGTON, MANCHESTER M20 9AF.****Pama
& Co****TEL:** 061-445 8918
061-434 5701
061-446 2437
Telex 666762 PAMA CO G
Fax 061 445 0978**Pama
& Co**

COMMUNICATION THE

QSL WAY



More names and addresses from QSLers all over the world, courtesy of David Shepherdson

Well, as this is the April issue, it's the time of year that we are coming into the Eyeball and Event season. Last year at this time I received some info, unfortunately too late for inclusion, about the Breakaway's CB Annual Eyeball held at the Old Hall, Gresley Wood Road, Church Gresley. This is an evening "do" with light entertainment. As I said, due to publications deadlines I received last year's info too late to include it and as I write this I have not had any info on this year's do. For details on what should be the 6th Annual Eyeball, date etc (last Friday of month?), a contact address is the Club Chairman, 80 Ridgeway Road, Ashby-de-la-Zouch, Leics. (Phone: Ashby 413473).

Again, like last year, I am getting details on a lot of Events, so many in fact from this month I'll have to restrict the number I can mention each month to those in the next three months, space permitting. So, events for this year I have details of include, in date order, the Cutty Sark QSL Club's 1989 Card Swap held at the Falcon Hotel, Ethelbert Road, Cliftonville, Margate. This is held over the weekend of 8th & 9th April. Entry fee is 50p per day. The next one is the GBQDC Fifth Annual Meeting held on the 16th of April at the Stanley Youth Centre, Stanley, Co Durham. Times between 11am and 4pm and is held indoors so, as the leaflet says, the weather is unimportant which was lucky the first year the meeting was held; it snowed! Since then however, the meeting has usually been blessed with hot sunny weather.

A couple of weeks later on the 29th

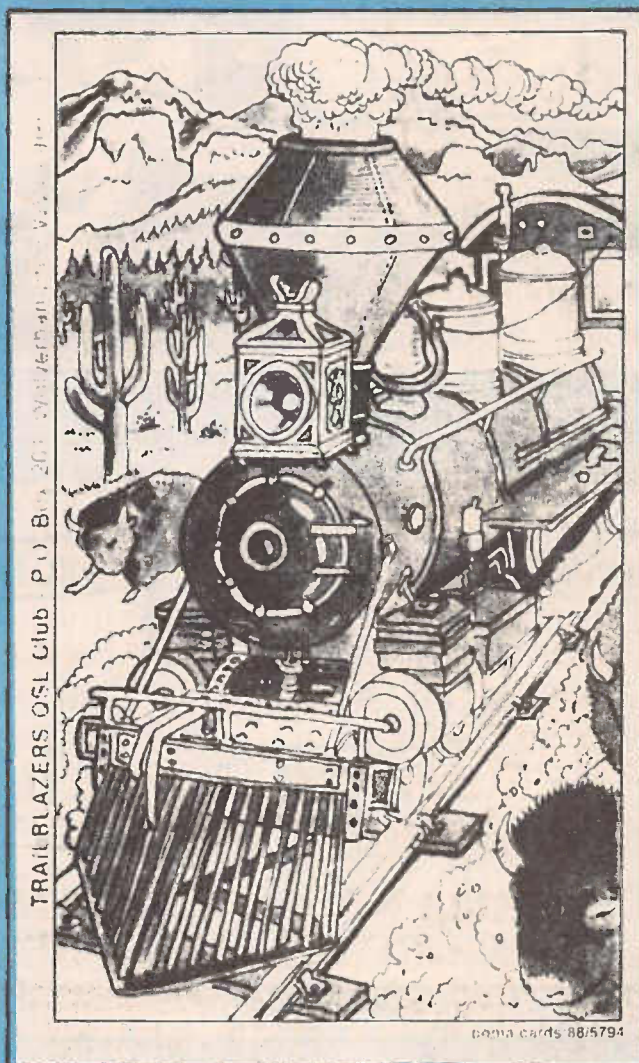

TRAILBLAZERS QSL Club P.O. Box 201, Stanley, Co Durham, Durham, England

coma cards 88/5794

QSL Service Addresses:

Charlie Cards	26 Edward St, Hartshorne, Burton-on-Trent, Staffs. DE11 7HG.
Currie Cards	89 Derwent St, Blackhill, Consett, Co Durham.
Impact Graphics	57 Moor Street, Earlsdon, Coventry, CV5 6ER.
Raymac Display	No. 2 Showfield Ind. Units, Pasture Lane Ind. Est., Morton, North Yorks. (Send £2 for Sample pack & £4 credit towards order).
Sharp Graphics	PO Box 3, Grangemouth, FK3 9BD. (0324-473432).

April between 12 noon and 11.30pm the CROCs are holding their Cardiff Eyeball. CROCs stands for Cardiff Radio Operators Club by the way. There will be trade stands, as indeed there are at all the events I have details on this issue. Also, live entertainment, separate lounge and bar, refreshments etc. Then in May there's the Tango Papa (83) Group's Charity Eyeball 1989 held at the Floral Hall, Southport. This is on Saturday 20th of May and runs for most of the day. There is an admission charge and also a council charge for car parking. All proceeds to the Club's chosen charity.

Next one is a June event, held over the weekend of 10th & 11th June by the Sea Smugglers at the Granville Hotel, Sea Road, Bexhill on Sea, admission 50p per day with Saturday night entertainments (£1). The following weekend (18th) the 1989 Sheffield Charity Gala and Eyeball is held at the British Steel Sports Ground on Bawtry Road, Tinsley (near Junction 34 on the M1). Clubs are welcome to attend and bring a stall, cost £5 for a 12 foot plot, and £10 for Trade Stands. Still in June, the next one I have details on is the Kilo Mike Eyeball at the Kirby Muxloe Sports Ground, Ratby Lane, Kirby Muxloe, Leicester. The date of this meet is 25th of June and the meeting is held in association with the Currie Card Collectors Club/Bank.

Moving into July, I've a few sparse details on the 7th South Coast Eyeball held at the Portslade Community College, Mile Oak between 10.30am and 5.30pm on July 16th. Admission free. Unfortunately I've no other details bar a contact address as the promised written details still haven't managed to get through the post to me!

So, what's the appeal of going to any Eyeball? Well, first of all you have the chance to put a face to the name on a QSL card, or a voice over the air. Then you can often pick up a bargain off one of the many club or trade stands as most QSL clubs will have special "Today Only" prices on cards, stamps etc. Some clubs will even have a number of packages to hand so that you can join there and then so you save postage costs if nothing else, and you will often find little, or not so little, groups of collectors swapping their latest cards hot off the presses! Also, for series collectors, the clubs will usually have some or all their cards available so you can fill in the gaps in your own collection! Anyway, the thing to do is look for one (or more) near to your area, and pop along taking a bundle of your cards and some money for when you spot a few bargains on the Club Stalls! But the main thing is that it is great fun and you will probably enjoy yourself on the day, and maybe even enjoy QSLing even more afterwards as you can now put a few faces to the names on the cards! I hope to attend at least three

SPAIN

EINSTEIN DX

SPAIN

1
E
D
2
5
P
L
A
C
E

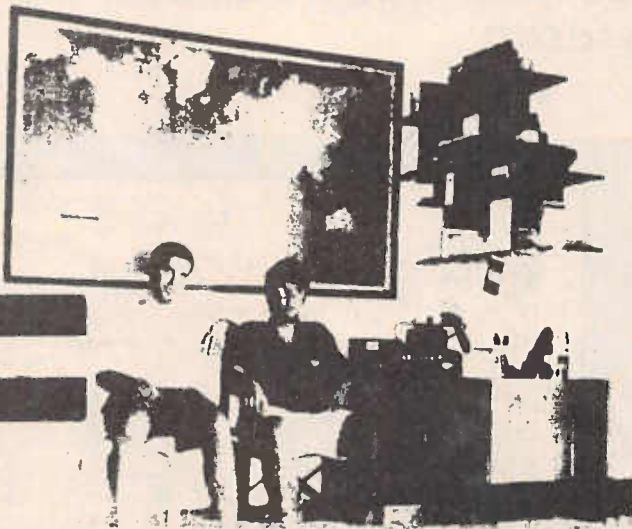

1
E
D
4
5
J
O
R
G
E

Black Rabbit 039

Whisky Sierra Group	
QTH	TIME
.....
RIG	DATE
.....
TWIG	MOBILE
.....
MIKE	HOMEBASE
.....
R.....S.....	HANDLE
.....
<input type="checkbox"/> SWAP <input type="checkbox"/> EYEBALL <input type="checkbox"/> PLS QSL <input type="checkbox"/> TKNS QSL	WS N°

	PERSONAL

P.O. Box. 64, Woking, Surrey, GU22 7EA, England

again this year as usual, perhaps a few more time. Look out for the Dragonrider Stall, I'll be somewhere around that.

As I look back at some of the events which were held last year, but details of which arrived too late to be included I can only ask that any organiser of any CB/QSL orientated event to get in touch as soon as possible, don't leave it to the last minute to let me have any details on your "do." If you think your event would benefit from being included here then as soon as a date, venue or whatever has been arranged, let me know! Please don't forget a contact address and bear in mind that publication details mean I need your info up to five months in advance of the event itself. If nothing else, it should get more than one mention that way! One last thing, please send it direct to my home address, not via the mag!

Events I've not yet heard about but will probably be held include the Trailblazers International Card Swap Meeting in Wolverhampton, probably with a new venue this year. Then there's what will be the Sixth Annual Eyeball held by the Mike Alfa's of Sidmouth in May (?), ditto Kendal & District Charity Eyeball. For details on these or any other events, the contact address should be found in the main club address slot.

When writing to any club for any info, please remember to include return postage for their reply as most clubs are run for enjoyment and as such out of the President's own pocket. When writing to a club outside your own country you should substitute two IRC's for the self addressed stamped envelope. These IRC's (International Reply Coupons) are available from your local Post Office and cost around 60p each. However, when changed back for stamps, they are only worth about 23p each.

Now, I've been asked to say that if anyone has been waiting for a reply from the Four Kings DX Club of Coventry this year, Don has been working away from home since Christmas and has obviously been unable to deal with the post that has piled up. However, if you can be patient, he will deal with the enormous pile just as soon as he can.

From Spain I've had some details on the Einstein DX Group in Valencia. The first letter came from a couple of members, Jorge & Paco who wish to QSL with the readers of this mag. Then I got another letter from Francisco who runs the Einstein Group. Membership to this Group will cost you \$5(US) and a few of your own QSL Cards. Wrap the dollars in between a couple of your cards for safety please. For your five dollars you can expect to receive your ED number, prefix list, certificate, 25 ED QSL cards, envelope, welcome letter, ED stickers, exchange invites etc, XYL gets free membership. Various extras

DR: 3208 - "OLD SPICE" - GLYN



QSL Club Addresses:

CROC's Cutty Sark	PO Box 119, Cardiff, Wales, CF4 6YD. 16 Bradenham Ave, Welling, Kent, DA16 2JG.
Einstein DX Group Four Kings QSL Club GBQDC.	PO Box 859, E-46080 Valencia, Spain. PO Box 19, Coventry, CV6 6ND. PO Box 5, Consett, Co Durham, DH8 8NG.
Kilo Mike Eyeball	PO Box 1, Kirby Muxloe, Leicester, LE9 9DP.
Mile Oak Breakers Eyeball	83 Oakdene Crescent, Portslade, Sussex.
North Wales Breakers Eyeball	PO Box 35, Prestatyn, Clwyd, LL19 9YH.
Romeo Delta X-Ray	10 Wallace St, Rutherglen, Glasgow, G73 2SA, Scotland.
Sea Smugglers	PO Box 139, Bexhill on Sea, E Sussex, TN40 2AF. Roadrunner, PO Box 275, Sheffield, S2 5HY.
Sheffield Charity Eyeball	Eyeball, PO Box 13, Southport, Lancs.
Tango Papa (83) Group Trailblazers QSL Club	PO Box 201, Wolverhampton, WV10 9HH. PO Box 14, Accrington, Lancs, BB5 6JL. PO Box 64, Woking, Surrey, GU22 7EA.
Tripe City Breakers Whisky Sierra Group	
<i>When writing to any QSL Club or Firm, always include return postage to assist with their reply, it does help. Please also mention that you saw their name in the CB Mag, thanks.</i>	

are available, details come with your membership package.

A request in from the Whisky Sierra Group of Woking in Surrey who say that they are a small group with members who wish to branch out into QSL swapping as well as DXing. If any swoppers would like to send a number of their cards care of the PO Box, the members will be happy to swop 1-4-1.

I've also been asked to mention that Currie Printers now offer Needs List Booklets for the dedicated collector, it doesn't matter which series of cards you collect, the booklet is suitable to most series and costs just 30p plus a first class stamp to cover postage. A couple of Currie Collectors who have asked to be considered for a quick mention in these pages are Mark (*Hill Billy*) and Glyn (*Old Spice*) who both send out an enormous package of cards. A new address for Toby Jug/Zebra One now has come my way, while from Dougie (Romeo Delta X-Ray Club) in Rutherglen comes the news that in addition to running two clubs and a newsagents shop, he is now a Committee Member of the Federation of Retail Newsagents all of which take up the lad's time! Congratulations on your appointment mate. Membership of the RDX is free, just five of your signed personal QSL cards and a large SASE (stamped for 100 grammes). For this very reasonable fee you receive your RDX unit number, welcome letter, ID card, mini-certificate, exchange cards and invites etc. Your XYL/M gets free membership, card etc. Extras available from the club also include rubber stamp, various club cards, stickers and sew-on patch. Just a reminder here for anyone who missed it the other month, the Boomerang Radio Group is behind in answering the mail as Roger (BR 001) has been at the bedside of his grandson in hospital following a heart transplant operation. So, please do bear with him, or drop him a line, with return postage, in case your package has gone astray.

Well, once again that's it, no more room so I'll close with a reminder that if you want a mention either for yourself or for your club, please drop me a line. For yourself, don't send a bit of paper asking for a mention, send me your usual QSL package which will give you a far better chance of a mention. For a club, please let me have some details of the club and please, please, do include an up-to-date membership application form so I can see what you offer and for how much. If you have a query which I might be able to help with, or you require a reply, please do remember to include suitable return postage and whatever you do, please send it to 3 Tarn Villas, Cowpasture Road, Ilkley, West Yorkshire, LS29 8RH. I'll either catch you again here next month, or maybe see you at the Stanley Eyeball, 'till then, take care!

QSLer Addresses:

Toby Jug (*Zebra 01*)
Mark (*Hill Billy*)

Glyn (*Old Spice*)

Jorge & Paco (*1 ED 45*
& *1 ED 25*)

9 The Precinct, Gainsborough, Lincs
27 Ford Street, Delves Lane, Consett,
Co Durham, DH8 7AE.

48 St Illtyds Road, Bridgend, Mid Glam
Wales, CF31 4JY.

PO Box 859, E-46080 Valencia, Spain.

EINSTEIN DX GROUP

ESTAMOS EN EL AIRE



Forthcoming Events:

April 8th/9th - Cutty Sark Swap Weekend.

April 16th - GBQDC 5th Annual Eyeball.

April 29th - CROC Annual Cardiff Eyeball.

May 20th - Tango Papa Charity Eyeball.

June 10th & 11th - Sea Smugglers Weekend.

June 18th - Sheffield Charity Eyeball & Gala.

June 25th - Kilo Muxloe Eyeball.

July 16th - 7th South Coast Eyeball.

August 19th - Tripe City Eyeball.

September 9/10th - North Wales Breakers Charity Eyeball.

Contact addresses shown in clubs section!

Pama & Co

WHOLESALE ONLY

OPEN MONDAY - SATURDAY

uniden 100



One of the most popular Mobile Rigs around. It has excellent sensitivity and anti 'bleed over' facility of the 200.

uniden 200



One of the best mobiles around with R.F. gain, tone control and other features, it has a good sensitive RX section with low 'bleed over'.

uniden 300



Undoubtedly the 300 is the best selling base station in the U.K. It's features includes mic gain, R.F. gain, power and tone controls and S meter. Value for money? It's unbeatable.

uniden 400



The first available rig for CEPT frequencies manufactured to the highest standards. Features include the mic gain, R.F. gain, squelch. 40 channels and a low 'bleed over'.

MIDLAND 77-805



Exceptional performance from this dual-purpose hand portable. Can be mounted under the dash and when away from the car - hiking, walking, fishing etc. - it will keep you in touch.

MIDLAND 77-104



It doesn't need to be big! The Mini Mobile is the smallest rig available but don't be deceived; it has exceptional performance for it's size.

JESAN KR200
JESAN CB950
Handheld
JESAN KR303:
The small budget priced rig.



DNT CONTACT 40
Now with Scanning Microphone
CEPT frequencies, 40 channels, F.M. Mobile superb performance, excellent sensitivity, Channel 9 indicator T/X indicator - unbeatable value.



NEW THIS MONTH ★

Now Available:-

**UNIDEN PC450E
HAS AT LAST
GOT APPROVAL**
Phone Us For
Details

Pama SUPA TRI

EXCEPTIONAL PERFORMANCE FROM THIS TRIPLE LOADED HIGH QUALITY ANTENNAE SIMPLY ... THE BEST!

INTRODUCTORY OFFER PRICE

£19.95

Also Available:-

The original PAMA TRI our No. 1 best selling aerial is still available made from the highest quality materials, the PAMA TRI has a performance unequalled by any antennae in it's price range.

£14.95

**FOR WHOLESALE ORDERS
PLEASE PHONE: 061-445 8918
AND WE WILL GIVE YOU OUR
IMMEDIATE ATTENTION**

ALL ORDERS DESPATCHED WITHIN 24HRS

Wholesalers for:-

CTE - ZETAGI - maxcom **lemm**

MIDLAND - **NEVDA**

HEMBRO - **Pama** **antler**

SADELTA - **uniden**

BREMI

THUNDERPOLE - SIRIO

LOOK FOR THE PAMA DEALER
STICKERS

**"WHEN YOU BUY UNIDEN"
YOU BUY RELIABILITY**

Pama House, 433 Wilmslow Road,
Withington, Manchester M20 9AF.
(3 minutes from M56)

Pama & Co

WE STOCK
Pama
CB PRODUCTS

Telephone: 061-445 8918 061-434 5701
061-446 2437 Telex: 666762 Pamaco G
Fax: 061-445 0978

SHARMAN'S WHOLESALE



MAXON MX 1000
CEPT TYPE APPROVED
NOW IN STOCK



MAXCOM 30E
Most popular UK 81 CB
now back in the UK.



OPEK 437
POWER MIKE



OPEK 436
DYNAMIC MIKE



OPEK 452
POWER ECHO MIKE

FANTASTIC NEW RANGE OF MIKES NOW AVAILABLE!

If you would like further details of the full range of CB equipment, telephones, In Car entertainment, portable TV and radio and all the benefits of dealing with one of the country's major wholesalers, then please phone 061-834-9571 for immediate attention.

3 BURY NEW ROAD, MANCHESTER M8 8FW
TEL: 061-834 9571 TELEX 665446 Sharma G FAX 061 835 3679

SHARMAN'S WHOLESALE

SHARMAN'S WHOLESAL

**Dial-a-Match
540 48"**

**Dial-a-Match
530 24"**

Half Breed

NEW

**Dial-a-Match
530C
cellular
look alike**



**Dominator
D2505
base loaded
open coil**

NEW

NEW

**Dominator
D2500
centre loaded**

NEW

**Dial-a-Match
512 12"**

NEW

**Enterprise ET6
24" cellular
look alike
mag mount**

NEW

**Enterprise
ET7
24" cellular
look alike
mirror mount**

VALOR'S UK Distributor since 1981

All available at the best prices

SHARMAN'S WHOLESAL

Base station CEPT rigs are rarer than hen's teeth and make rocking-horse droppings look positively commonplace. Now the long wait is over with the newly-arrived Satcom Scan 4000. With the signature on its DTI type-approval certificate barely dry, it's the first homebase unit to pass before the steely gaze of Saul Wright . . .



BACK ~to~ BASE

I couldn't resist a peek inside, even before I'd switched it on – had Satcom designed a purpose-built homebase rig, or would the Scan 4000 turn out to be a modified mobile. The latter turned out to be the case, and why not? Why on earth go to all the trouble and expense of re-designing printed circuit boards when all you really need to do is upgrade an existing, and proven circuit board to mains operation. Well, it's not quite as simple as that, the Scan 4000 is a good deal more sophisticated than the average mobile rig, to begin with it has a number of features rarely found together in one place, not least because a mobile rig simple doesn't have the room for all of the extra knobs and buttons . . .

Let's begin with the traditional guided tour. First the size, it measures 328 x 70 x 290mm; to put that into perspective, it's a little smaller than a typical 'midi' hi-fi component. The cabinet has a pair of flip-down feet at the front so that it sits



at a convenient angle when on a tabletop or desk. Around the back there's a standard SO239 antenna socket; an extension speaker jack; a socket for 13.2 volt DC (a reliable pointer to its mobile origins) the mains fuse and mains lead. The front panel is neatly laid out with the green LED channel display and S-meter in the middle and the major and minor controls either side. By the by, extra points to Satcom for the big bold meter – it's a moving coil type, easy to read, unambiguous and reliable, much better than a flashing bar-graph in my opinion.

So what do all the knobs and switches do? From right to left the top row of push-buttons are: power on/off; local/Dx (RF gain); mike compressor and auto scan – we'll take a more detailed look at the last two in a minute or two. Below them there's a standard four-pin mike socket and rotary controls for tone and squelch. Underneath the LED channel display there's two more buttons; one for high/low RF output and the other channel 9 priority. Now for the two big knobs – the innermost one is channel selection, it's not a rotary control as such. It's centre-sprung, so

that gently turning it to the right steps the channel up one by one, turning it to the left decreases the channel numbers. Turning the knob firmly until it reaches either of its end-stops makes the channels go up and down at the rate of around two to three a second. Next to that there's the volume control, sorry, nothing unusual here, just a boring old knob . . .

The two displays, as we've already said are fairly straightforward, but it's worth emphasising that they're a good deal bigger than those on a normal mobile rig, and that can't be bad. The only indicators are a pair of LEDs for Tx and Rx mode, and above their respective buttons – LEDs for local/DX, mike compressor and channel scan functions. That just leaves the mike, again a fairly normal looking design, so without more ado we'll plug it in, switch on and see what happens . . .

No nasty surprises, the Scan 4000 is very CBER-friendly and you'll only need an occasional glance in the instruction book to figure out what everything does. The two controls mentioned earlier deserve a fuller explanation. First the mike compressor – this is designed to even out the peaks and troughs in the modulation and theoretically make you easier to understand the other end, whether you're trying to swallow the mike, or shouting at it across a room. The Auto Scan feature is basically a marriage between the channel change and squelch controls. When in the scan mode the unit steps through the channels until it comes across a signal that breaks through the squelch. At full tilt the scan rate is round two to three channels per second, though it seems as though it might be a little variable as it may take a moment or so to get up steam . . .



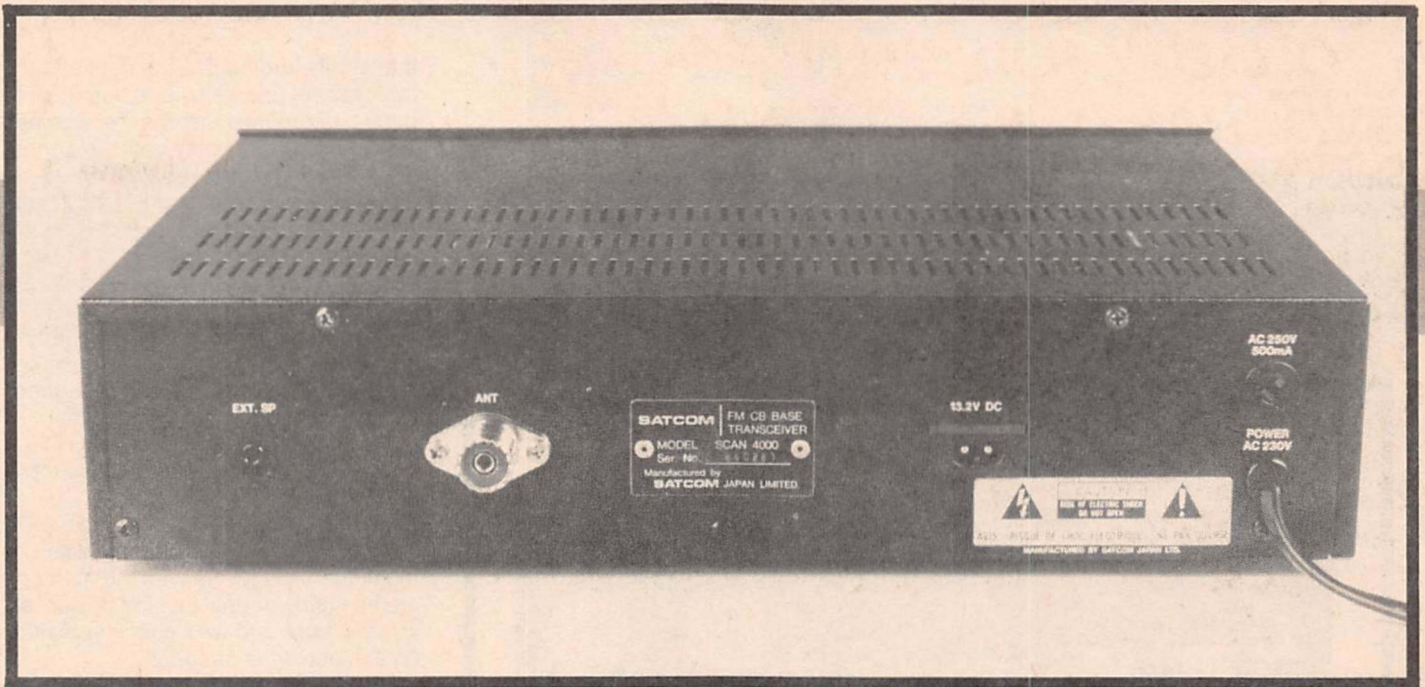

In Use

There's nothing I like more than testing a base station indoors when it's cold, wet and wintry outside. The Scan 4000 didn't disappoint – connected up to a home-brew half-wave of known performance, it gave a particularly good account of itself. The fairly substantial cabinet (compared with a mobile rig) and a useful tone control combined to produce clean crisp audio output – no need for an extension speaker here, the in-built one is well above average.

Control operation couldn't be faulted – large, easy to find knobs means there's no fiddling around – everything falls readily to hand, and does what it's told. The channel changer takes a little getting used to – and for some it may be an acquired taste. It certainly works okay, but compared with the ease of flipping to and fro on a conventional rotary channel selector; the one here can be a little irritating for the first few minutes, especially if you're not paying

attention when it's skipping through the band at high speed – it's all too easy to go whizzing past the required channel number. However, that's a small niggle, and within a few minutes, even the most ham-fisted knob twiddler is back in control.

Transmitted copy, according to our regular test collaborators was average to good. Without any prompting whatsoever most people knew immediately it was a homebase rig – the acoustics of a typical bedroom are a dead give-away . . . Anyway, the general consensus was most favourable; the use of the mike compressor didn't seem to make much difference to most people. Output power, according to our venerable meters was nudging the legal limit which meant that fed through the trusty antenna we were getting out as far as possible, without incurring the wrath of the boys in blue. In practical terms this resulted in at least two reliable base to mobile contacts 20 miles away, without any trouble at all.

CB Specs

Make/model:	Satcom Scan 4000
Channels:	40, FM CEPT (DTI approved)
Facilities:	Sequential channel selection, channel 9 priority, local/dix RF gain, channel scan, mike compressor, hi/low power output
Controls:	Rotary volume, tone, squelch, channel selector (see text), push-button lo/dx, ch9, scan, mike compressor, hi/low power
Displays:	2-digit LED channel display, moving coil S-meter, 5-segment LED indicators ddx/loc, mike compressor, auto-scan
Mike socket:	Standard 4-pin
Power supply:	240 VAC mains & 13.2 VDC
Dimensions (mm):	328 × 70 × 290
Price range (£):	225
Supplier:	Nevada, 189 London Road, North End, Portsmouth, Hampshire PO2 9AE (0705) 660036.

CB Verdict

Tx Quality:	[*]	[*]	[*]	[*]	[]
Rx Quality:	[*]	[*]	[*]	[*]	[]
Ease of use:	[*]	[*]	[*]	[*]	[*]
Construction:	[*]	[*]	[*]	[*]	[*]
Value for money:	[*]	[*]	[]	[]	[]

Summary

You may have noticed that we've made no mention of the price – unfortunately this is the only piece of bad news – the Scan 4000 will set you back around £225. That's not cheap, so let's see how that can be justified. To begin with it's extremely well built, there's no reason to suppose why it shouldn't enjoy a long and healthy life. It's well designed, easy to use and works a treat. Finally it looks the part, it's not flashy or plasticky, and the cosmetics are bang up to date. There will be cheaper homebase units around, but this will be the standard by which they are judged, and I wouldn't mind betting that few, if any, will match up to it . . .

QUALITY EQUIPMENT FOR THE SERIOUS CB'ER HAS OUR NAME ON IT —

MAIL
ORDER

ALSO AVAILABLE BUT NOT
ILLUSTRATED IN THIS
ADVERTISEMENT

MOONRAKER®



SPM 1000 £24.95
SWR Power Range — 1-100 watts
Frequency Range — 1.5 to 144 MHz
Matcher Range — 25 to 40 MHz
Size: 130mm X 69mm X 32mm

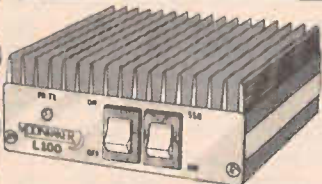

L100 LINEAR £39.95
Output — 50-80 watts
RF Input Power — 1-4 watts
Power Source — 12-14 volts
Freq. Range — 26-30 MHz
Current Drain — 3-4 amps



L30 LINEAR £19.95
Output — 20-25 watts
RF Input Power — 1-4 watts
Power Source — 12-14 volts
Freq. Range — 26-30 MHz
Current Drain — 3-4 amps



PR35 PREAMP £19.95
Boost your incoming signal
Frequency — 26-28 MHz AM/FM
Gain max. +30dB min. -30dB
Input Power — 50 watts max.
Power — 13.5 volts ± 10%
Size: 55mm X 30mm X 80mm

RINGO LOOP £3.95
Increases your transmit and receive performance by controlling over modulation distortion at close range. Gives your mobile antenna a 360° primary ground plane.

FUNKMASTER SPEAKER

The best quality CB speaker on the market complete with noise filter. 5.5oz Magnet, max power 8 watts. Size: 123mm X 126mm X 77mm

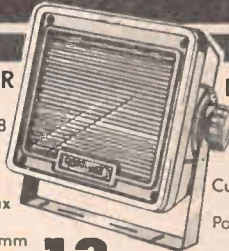

£13.95

POWER MIKE

Output Level — 0-2 volts
Voltage Gain — 40dB
Current Drain — 2.5 mA
Power Supply — 9 volt Int. battery
Output Impedance — 1 kohm



Also available: £19.95
Replacement Mike Echo Mike Roger Bleep Mike
£9.95 £29.95 £29.95

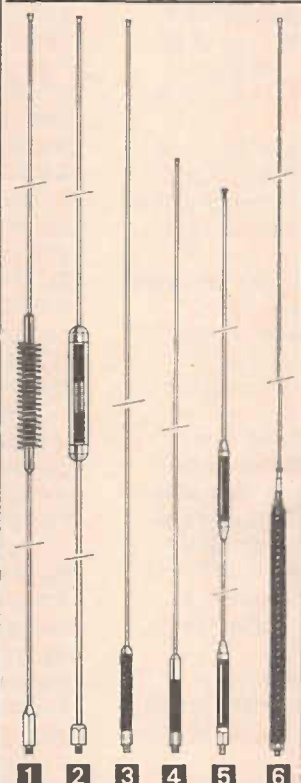

1 FIREFLY £16.95
Our best selling antenna. Frequency — 26-30 MHz. Power — 500 watts. Length — 1467mm. Open spring coil outside PVC rod gives low losses and low angle of radiation.

2 GOLDEN LANCE £19.95
Frequency — 26-30 MHz. Power — 1000 watts. Pre SW R:td with 17/7 PA gauge stainless steel tapered whip. Total length — 1500mm. 1/4 UNF fitting.

3 FM 27 £11.95
26-30 MHz. Power — 500 watts. Length — 1450mm. 17/7 PA stainless steel tapered whip. 1/4 UNF fitting.

4 MISTRAL £7.95
26-30 MHz. Power — 500 watts. Length — 990mm. 17/7 PA stainless steel whip. 1/4 UNF fitting.

5 TWIN MIDGET £12.95
26-30 MHz. Power — 500 watts. Length — 1275mm. 17/7 PA stainless steel whip. 1/4 UNF fitting.

6 BULLWHIP £9.95
26-30 MHz. Power — 500 watts. Length — 1650mm. 17/7 PA stainless steel tapered whip. 1/4 UNF fitting.



7 SKYPLANE £16.95
Acts as a ground plane to your favourite mobile antenna for use as a base antenna. Standard 1/4 UNF fitting.

8 LAZER £18.95
26-30 MHz. 1/2 wave base antenna. Power — 1000 watts. Length — 1000mm. Does not require a ground plane.

9 GAMMA TWIN £16.95
Frequency — 144-148 MHz. Power — 20dBw. Length — 2000mm. Antenna consists of a 1/2 wave folded radiator voltage fed by a 1/4 wave folded matching stub (T-match).

10 MINI GP £19.95
26-30 MHz. 1/2 wave. Power — 1000 watts. Length — 1550mm. Gain — 3dB. Complete with mounting bracket for poles.

10-100 MINOR	£59.95
10-101 MAJOR	£79.95
10-102 MASTER	£79.95
11-011 SKYPLANE REPAIR KIT	£3.95
11-600 1/4 WAVE SILVER ROD	£18.50
11-601 1/4 WAVE SILVER ROD	£19.95
11-902 1/4 WAVE	£14.95
11-903 1/4 WAVE	£16.95
12-025 C/L GOLDEN LANCE 2000	£19.95
12-026 B/L GOLDEN LANCE 1000	£17.95
12-080 TWIN TRUCKERS	£22.50
12-817 SUPER MIDGET	£9.95
12-983 CALFWHIP	£8.95
12-984 1/4 TAXI ANTENNA	£8.95
12-986 1/4 WAVE TAXI ANTENNA	£4.95
12-989 C/L MINI MAG ANTENNA	£12.95
15-011 COMPLETE GUTTER MOUNT	£9.95
15-016 GUTTER MOUNT COMP. WITH DV MOUNT CABLE & PLUG	£10.95
15-020 SO239 GUTTER WITH CABLE COMP. WITH SO239 MOUNT AND PLUG	£10.95
15-026 LIMPET MAGNET 1/4 MOUNT ONLY COMP. WITH CABLE & PLUG	£8.95
15-037 PIGWY MAGNET 1/4 MOUNT ONLY COMP. WITH CABLE & PLUG	£7.95
15-039 SO239 MAGNET & DV COMP. WITH CABLE & PLUG	£9.95
15-999 RIG TRAYS	£3.95
21-101 SPM 1000	£24.95
21-914 S.W.R. METER	£8.95
21-919 S.W.R. / PWR METER	£9.95
22-904 P.R. 35 PRE AMPLIFIER	£19.95
25-100 3/5 AMP GOLD P.S.U.	£29.95
25-200 5/7 AMP GOLD P.S.U.	£39.95
25-300 12 AMP GOLD P.S.U.	£79.95
25-920 3/5 AMP P.S.U. (B.S.)	£19.95
25-924 5/7 AMP P.S.U. (B.S.)	£24.95
25-930 12 AMP P.S.U. (B.S.)	£75.00
26-001 NICAD CHARGER	£7.95
36-003 CS-3 ECHO MICROPHONE	£29.95
36-004 CS-4 POWER/ROGER BLEEP MICROPHONE	£29.95
36-023 DYNAMIC MIC. WITH PLUG	£7.95
36-200 REPLACEMENT MICROPHONE	£9.95

* PLEASE STATE RIG MAKE / MODEL WHEN ORDERING

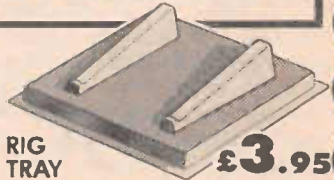

RIG TRAY £3.95
An ideal stand for your mobile radio when using it at home.



RIG SIDE SCREWS £1.25 pair
Spare screws for the mounting of your radio to its bracket. Please state make of radio when ordering.

MINI 27 W/TALKIES — SET OF TWO
Power Output — 200 mA
Frequency — 27 MHz
Size: 52mm X 155mm X 22mm
Complete with carrying case and strap and earphone socket



£39.95

SEND TO: MOONRAKER® 39 Potters Lane, Kiln Farm 4, Milton Keynes, Bucks. MK11 3HQ. Telephone: (0908) 260099 Fax: (0908) 261188 Telex: 826623 KNIGHT G.

QTY.	ITEM	£

NAME _____ ADDRESS _____

I enclose cheque / PO for payable to Moonraker

Postage & Packing ADD £2.00. Orders Over £30.00 R&P FREE.

I wish to pay by ACCESS VISA (tick)

PLEASE USE A SEPARATE PIECE OF PAPER IF YOU NEED MORE ROOM.

You know," mused Ritchie, sitting on the edge of his chair, "that at the rate technology is going we'll soon be redundant!" "How come?" inquired

Danny.

"Well, all this science stuff about computer diagnosis, self-replicating space probes and stuff like that - pretty soon there'll be computers analysing the faults on these sets and then controlling robots to repair them." Danny considered this vision of the future for a moment.

"The only trouble is, Ritchie, that by then CB equipment just won't be worth repairing; some of it isn't now," replied Danny. His assistant stared into space. "After all," continued Danny, "production costs are going down, and by the time computers can do all that they won't need to. It'll be so cheap for computers to mass-produce radios there won't be any need."

"Hmm, I see your point." Ritchie glanced up at the clock. "Hey, it's almost one. We'd better get going again." He took a last gulp of coffee from his cup, and cleared his bench ready for the first job of the afternoon. He walked over to the 'For Repair' rack, and scanned the radios sitting on its shelves. Meantime, Danny was clearing his own bench.

"Danny!"

"Yeah."

"How often do we get one of these old tube radios to repair?" asked Ritchie, holding up a transceiver.

"Quite often. Even though technology is advancing, as you were just saying, old tube-type sets are still going strong and giving good performance. Many people like to hang on to them."

"Gee, I'd have thought they'd have disappeared years ago."

"Why? After all, they do the job and in

quite a few respects they're better than their transistorised counterparts."

Ritchie looked closely at the radio he was holding.

"How old would you say this one is then?" Danny walked over and examined the transceiver.

"At a rough guess, about 20 years." Ritchie thought hard for a while.

"I must admit," he said, "that I can't see many of the current radios being around and working properly next century! Some of them only seem to last a couple of years."

"That's very true," agreed Danny. "It's not helped by the fact that with CBs so many people start fiddling inside them."

"I must confess I'm not too up on tube circuits," Ritchie informed Danny. "I've never really come across them, only in books. Hey, as it's the first one we've had in to repair since I started here, how about going through it together and giving me some tips on this type of set?" Danny looked at the rack, almost sagging under the weight of the radios awaiting repair.

"There is rather a lot to do here," he complained. He paused. "Oh, I guess it's okay. After all, you'll come across plenty more of these, so some time out now wouldn't hurt."

"Thanks Danny," responded an eager assistant. "Your bench or mine?"

"You'd better bring it over to mine," said Danny. "Most of the test gear seems to have found its way there at the moment!"

So Ritchie carried the radio over to the bench while Danny searched the filing cabinet for the service information on the radio in question. When the pair had seated themselves comfortably, Danny connected the radio to the appropriate outlets, and switched on.

"It's completely dead," stated Ritchie. "Absolutely nothing!"

"Give it a chance to warm-up already!" replied Danny, a little snappily. "It doesn't come on immediately like transistors do you know."

"Sorry," said Ritchie, feeling a little

silly at having overlooked something so simple. He turned to the booklet that Danny had opened out at the schematic diagram. "Is that it?" he asked, surprised.

"Yep. That's it. Before you see one of the advantages of tube circuitry - it's often much simpler than solid-state wiring."

"I can count seven tubes. Can you give me a quick run-down?"

"Sure," replied Danny, pulling his scruffy notepad toward him, and selecting a pen from his pocket. "Here's a block outline of the set." He started scribbling quickly on the pad (fig 1). "The RF side of the transmitter is handled by one tube, a 6CX8."

"Just one device for all that?" said Ritchie incredulously.

"Just the one. It's actually a double tube with a triode and a tetrode section. The triode is wired as an oscillator and frequency doubler, and the tetrode is the main amplifier to deliver power to the antenna. The oscillators in these sets didn't have phase-locked loops like the modern sets do. All they used here was a bank of eight crystal sockets selected by the channel switch on the front panel. Users go out and buy crystals for the channels they want and just plug them in. There's another eight crystal holders for receive, connected to the second section of the channel switch."

"So you need two crystals for each channel?"

"That's right. It seems strange to think that these days we use one crystal to generate 40 or more channels." Ritchie was looking expectantly at Danny, who, taking the hint, carried on. "There are two tubes for the audio side on 'transmit,'" he continued. "One, a 12AX7, is a double tripod used to provide the necessary gain from the microphone input. This is a two-stage amplifier. This feeds into the power amplifier, a 6AQ5 pentode. The 6CX8 in the RF side is plate-modulated by a transformer. That was a very common method in these radios. With an AM transmitter working

This month, Ritchie and Danny mull over the differences between trannies and tubes

CB BENCH

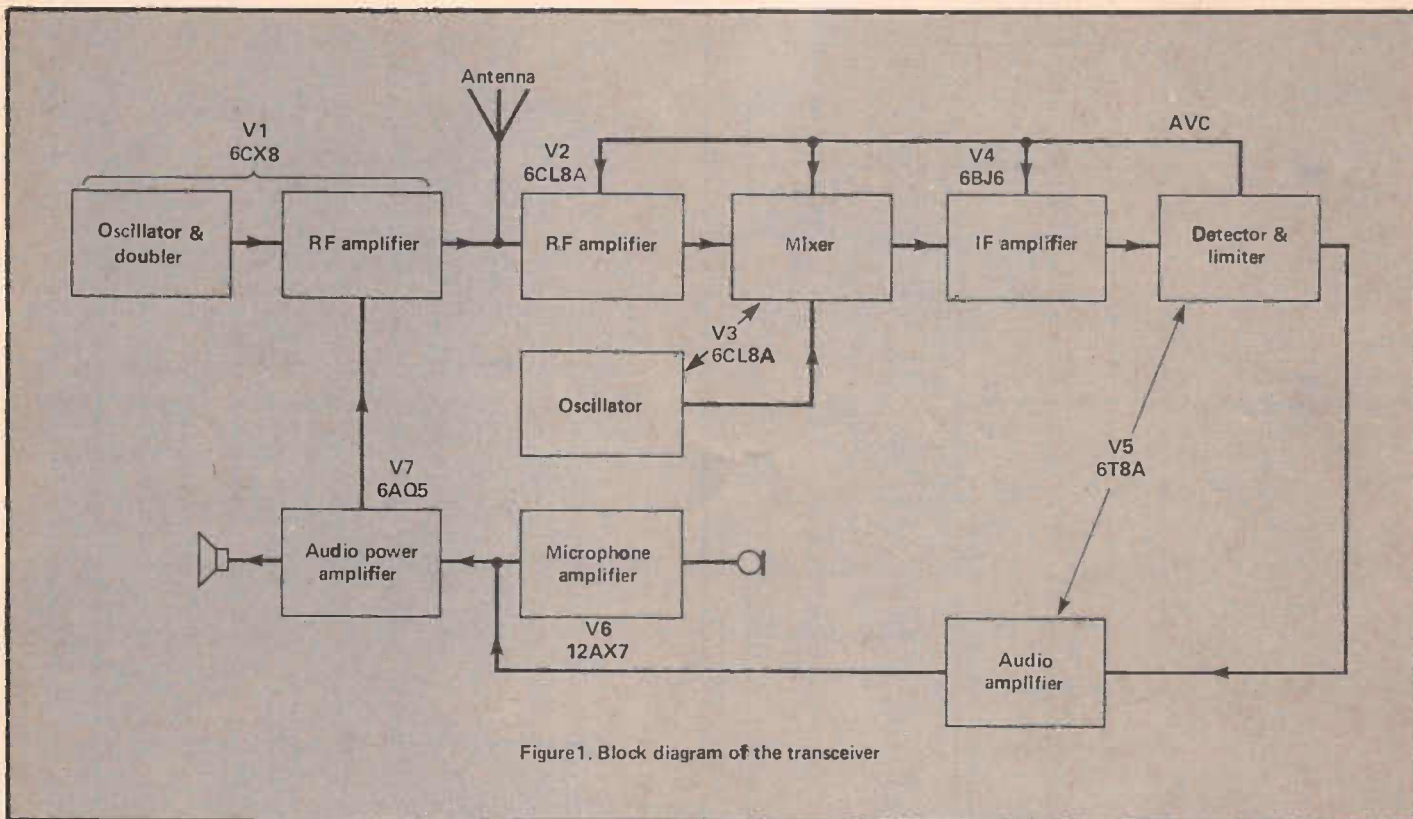

Figure 1. Block diagram of the transceiver

in this fashion, the audio amplifier needs to be able to deliver half the RF carrier power in order to obtain 100% modulation. With 4-watts output you'd need at least 2-watts of audio. Okay?"

"I think so."

"And that's all there is to the transmitter. Simple isn't it?"

"I think I'm in the wrong time," moaned Ritchie, sadly.

"All the sets I get now have about six transistors, three ICs and twice as many resistors and capacitors at least to do that!"

"True," agreed Danny. "It is much less complex. Are you ready for the receiver now?"

"Fire away."

"Right. First we have a two CL8A tubes. These are a triode and tetrode combined. The first one has the tetrode section wired as an RF amplifier. The triode isn't used. The second tube is a combined mixer-oscillator. The triode is wired as the oscillator, just the same as on the transmitter, and the tetrode is the mixer. We're used to seeing double-conversion in straight AM receivers these days, but when this set was made double-conversion was a luxury. They just mixed the incoming signal straight down to 455kHz." Ritchie looked as if he was happily absorbing this information, so Danny continued.

"The next tube is a 6BJ6 pentode, used as the IF amplifier, and the output from that couples through the last IF transformer to the detector. This is part of a 6T8A, a triple-diode and triode combined. The diode sections are the detector, AVC and noise-limiter, and the

triode is the first audio amplifier. Those diode sections take the place of all the semiconductor diodes you find in that part of the circuit in modern radios. For the final audio amplification, the manufacturers used the same audio pentode as on transmit, the 6AQ5. This was quite a normal arrangement. The primary of the audio transformer feeds supply voltage to the plate of the audio and RF amplifiers and allows amplitude modulation of the RF final. A secondary winding connects to the speaker to allow the stage to double as audio amplifier on receive. Neat huh?"

"And is that it?"

"Just about. The only remaining section is the power supply. That uses metal rectifiers rather than tube types to save space." Ritchie examined the schematic.

"The primary side of that power transformer looks pretty complicated," he observed. "And what's that thing marked 'VIB' supposed to be?"

"That's a vibrator."

"Now I've heard it all. Why would anyone want to vibrate the set?!"

"Not like that you idiot!" retorted Danny. "You're used to seeing mobile transceivers run straight from a 12-volt automobile supply. That's fine because the circuitry only requires a low voltage. Tube circuits need about 200 volts though, so there's a problem."

"Hey, I'd forgotten about that. It still doesn't tell me what the vibrator's for?"

"Transformers will only step up AC voltages, not DC. A car supply is DC. The vibrator is used to convert 12-volt DC energy from the battery into a sort of

AC that the transformer can handle. It does this by using an electromagnet and vibrating contact to switch DC on and off to the primary of the transformer. The result is hardly a pure sinewave, but it's enough for the transformer to do its job and get a few hundred volts on the secondary. The transformer output is only going to be rectified and smoothed back into DC, so it doesn't really matter."

"Phew! Caveman stuff!" laughed Ritchie.

"It may seem like it now," said Danny, "but that was the way it was done. How else would you get the voltages required? You could use a motor-generator set-up, but that's getting a little extreme just to run one radio."

"Why not use an oscillator to generate the AC for the transformer?"

"And how do you propose to power the oscillator?"

"Oh . . . I hadn't thought of that!" Ritchie pondered on this question for a moment. An idea struck him. "Transistors were around twenty years ago," he finally said. "Why not use transistors for the oscillator, like they do in those inverters now?"

"You may take for granted high-power FET devices like those, but they just weren't available then. It's only recently that transistors have started to be used in more high-power circuits. It may have been just possible, but the resulting circuitry would be so bulky and expensive it wouldn't be worth it. They could've just built the whole thing from scratch with transistors and simplified the power supply."

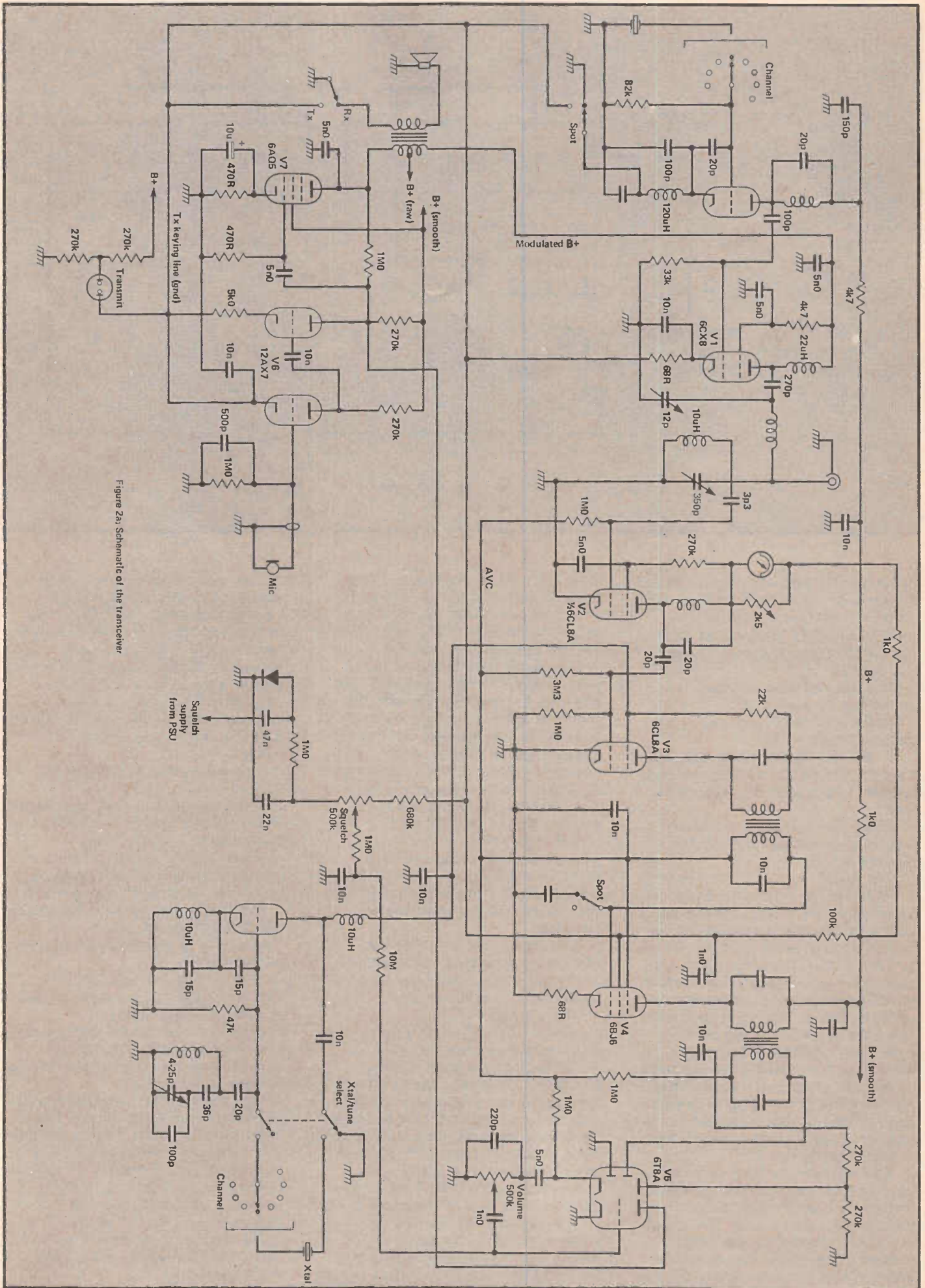

Figure 2a: Schematic of the transceiver

"What other advantages do tubes have over transistors, apart from simpler circuitry? I'd have thought all that heat and size was against them."

"That's true. It's one of the biggest advantages, along with the need for a high-voltage supply in mobile equipment such as this. They're more robust on the whole. Half a second of reverse polarity on a transistor or IC and it's gone. Tubes can withstand incorrect operating conditions far better than semiconductors. Running with a severely mismatched antenna, or shorted feedline can sometimes destroy the output stage of a modern radio almost instantaneously. Tubes can drive a mismatch without such catastrophes. And if one does go up in smoke, or is suspect, it's easy to pull it out and try a new one without messing around desoldering delicate wires."

"Is that it?"

"Sometimes impedances match tube circuits better. The input to the grid of an audio amplifier is high-impedance. Bipolar transistors inputs are much lower impedance. You see that black box on the top shelf?"

"Yes."

"I don't think we've used it since you started here, but it's an audio signal tracer. I built it about five years ago, and I used tubes in preference to transistors."

"What!" interjected Ritchie in disbelief. "You mean you actually built something using tubes?"

"And why not may I ask?"

"Well, fixing them is one thing but nobody uses that stuff anymore to actually build new equipment." Danny

smiled. It was an argument he'd gone through many times before on the air, and face to face.

"Listen Ritchie, there is absolutely no reason why people shouldn't avoid transistors if they want to. For an audio tracer a high-impedance input is just right. If I ever accidentally touch the probe onto the wrong point I've only got to change that one pentode at the front-end. If it was transistorised I'd probably have to start from scratch almost. As you yourself said, the circuitry is simpler, and besides, I happened to have all the parts laying around in my junk box."

"You didn't have to buy anything?"

"Nope." Danny thought hard for a moment. "Well, actually yes. I had to get one B9A holder, do you realise how difficult they are to find these days? Now let me ask you a question."

"Go."

"How does the cathode-ray tube in a television work?" Ritchie froze.

"By thermionic emission, the same as here," he replied eventually.

"And when was the last time you called your cousin in New Zealand?"

"Last week actually."

"Well, the chances are your call went via satellite. How do you think the RF is beamed-up to the thing? Transistors may be advancing fast, but they use travelling-wave tubes and klystrons in satellite equipment, which work on the same principle." A look of horror passed over Ritchie's face at having been caught out.

"Okay," he said resignedly, "I must admit I was perhaps, possibly, maybe, being a little too hard." Danny grinned.

"Now how about we look at this set?" he said, advancing the volume control. A few signals filled the workshop, along with the crackle of a motorcycle that had just passed the window outside. Danny tried the other channels, noting that only six channels were fitted, the other two being left spare.

"Sounds all right," commented Ritchie.

"It does," agreed Danny. "Let's see what it's like on transmit." So saying he picked up the microphone and held in its PTT button. The radio became silent, but the transmit pilot light remained dark. Danny examined the power meter he had connected in-line with the transceiver earlier. Nothing. He looked quickly at the schematic and then switched the set off, turned it around on the bench and started to remove the back cover.

"No transmit, huh?" said Ritchie, quietly.

"No transmit," confirmed Danny, now carefully laying the back on the bench. He peeked inside the now open transceiver. "I don't believe it!" he said calmly.

"Don't believe what?"

"It's nothing more simple than a microphone wire broken - look!" He pointed an accusing finger inside at a tag strip where the microphone cord entered the front of the set.

"Hey!" said Ritchie. "I've only just noticed the microphone is wired straight into the set; there's no connector."

"Quite a few makers did that a number of years ago," Danny told him. "Perhaps people weren't so worried about using stupid echo boxes and junk like that, so it wasn't necessary."

"I've got an echo box on my rig at home," replied Ritchie, as if daring Danny to comment further. The look of disgust on the technician's face made him stop and change the subject.

"Shall I get that wire back on?" he asked.

"Good idea. All that time for one broken wire. Oh well, at least you've had a guided tour of a tube radio. Now I'd better get back to my work - just look at those sets waiting for repair!"

And as another technical discussion between Danny and Ritchie came to a close, a twenty-year-old radio was soon restored to full operation. A few minutes later Ritchie carefully carried the now functioning radio to the 'Repaired' rack, and then headed back to the 'For Repair' rack. He selected a small portable unit, obviously of a much later generation than his previous job. Silently, he examined the exterior, and noticing a small connector on the side, a puzzled look came into his eyes.

"Hey, Danny! Can you come here a moment please?"

Thus started another discussion where the previous one had ended.

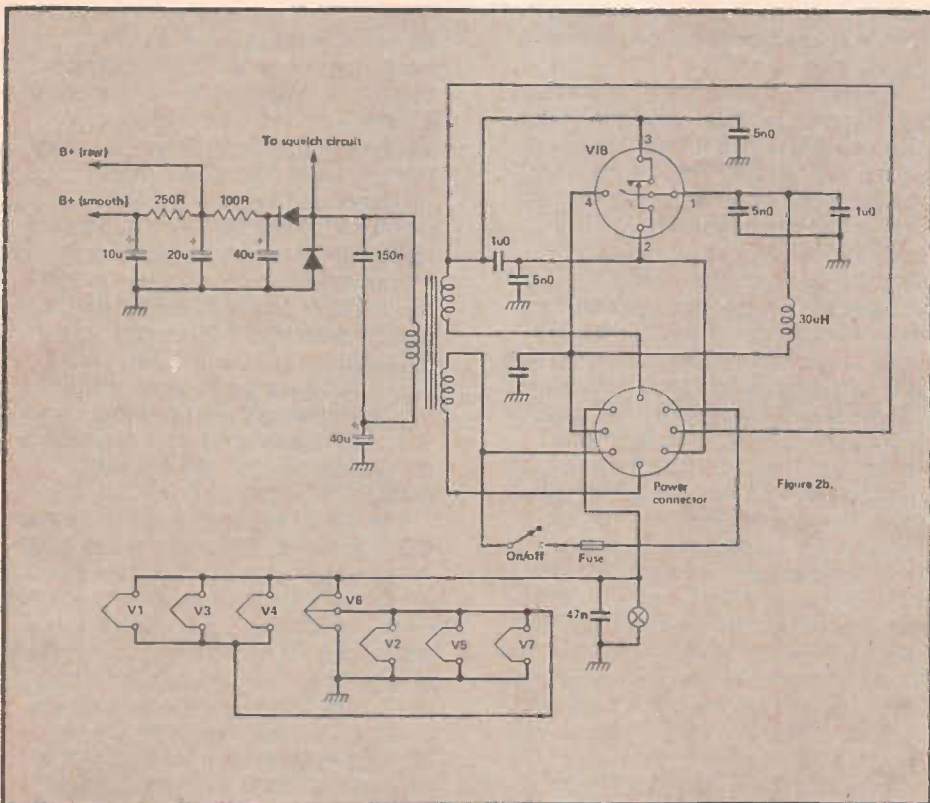

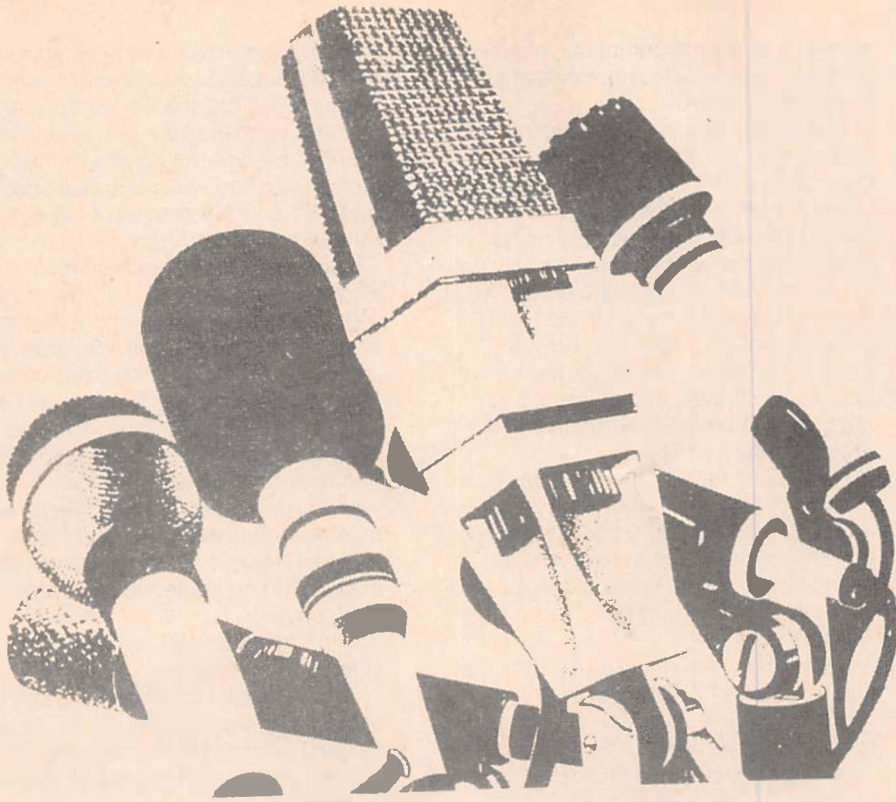

OVER THE AIR

I magine, if you can, it's a bleak October morning (around 3.30am) and the mist is laying waist-high across the field. As you wipe away the condensation from the inside of the car window and peer out, you can see the full moon shining through the low, spartan clouds. The stomach pain that woke you is increasing by the second, almost to the point of creasing you in half. 'God, I wish that I hadn't drunk that much beer during the previous evening.'

All alone, you face up to the fact that you will have to venture out into the cold air and go to the toilet. Looking out from the car, you survey the area around to make sure that no other person is within sight. The thought runs through your head that you have two choices; you can either get dressed and wander over to the toilet block some hundred yards or so away, or stand in the field naked and hope that no one ventures out. The latter choice seems the best, as the mist would blot out anyone's vision of those

most 'private parts' but the first one is the one that you decide to take - modesty wins.

You struggle out of the sleeping bag and rush to get dressed. By this time the 'need to go' is almost at breaking point so, falling out of the back of the car and with a small torch in your hand, you find your way into the toilets. The lights are on and the door is unlocked. As you push the door aside the warm air from the wall-mounted heater hits you in the face. 'I must be bloody mad sleeping in that cold car when this place is so warm,' you mutter out loud, knowing that no-one is around to hear you talking to yourself.

The pain has gone within seconds as you stand facing the wall with the torch clutched under your armpit. The prayer has been answered and 'the need to go' has been and went. With eyes still half-closed and hands washed, you pull open the exit door and the cold air seems to wrap itself around the parts of you that are not covered up. With the door shutting behind you, you try and find your car somewhere across the field. The torch battery has almost given up the ghost and the dew from the grass has just about seeped through your shoes. Just then, you spot the shape of what you think is your car and aim for the outline making sure that you don't trip over any guidelines from the odd tent dotted around. Eerie thoughts run through you mind and stories of ghosts, loonies and country mysteries filter into your brain as you wade through the mist. 'Don't be so stupid,' you think to yourself as you peer down towards the ground and notice that you can't even see your feet.

It's only another 20 feet until you reach the car, and safety. Ten more feet

and your hand reaches out for the unlocked car door when the growling and barking of a dog somewhere under the mist and heading your way makes you run the last few feet in a time that would amaze Seb Coe. But, where the bloody hell is it coming from? Are you running towards it? At this point, you don't really care and you open the car door, leap in and slam the thing closed. The sweat is, by this time, making you feel quite cold and you peer out of the window muttering, under your breath, swear-words which amount to doubting the animal's parentage. Then a voice rings out loud enough to be heard across the silent field: "Shut up, Prince, and lay down! I'm trying to go to sleep." Then the final insult - the pain's back and I want to go to the toilet again.

Yes, it is a true story because I was that person, and it happened at the Sunrisers Eyeball back in October '88. Isn't it funny the things that we go through at eyeballs!

Talking on the new mid's the other evening, the conversation was switched onto the subject of 'deregulation' by a local CBer. After listening to a number of people's views on this issue, it became clear that everyone had their own ideas and some were very interesting. But, overall, the outcome of this two-hour debate was that 90% were against the idea. It was felt that users would need to know more about what the DTI had in mind and whether or not this would improve CB in the UK. Whether they intend to do away with *all* of the legal restrictions, and if they would drop the sale of licences. Many were concerned that, should this ever happen, we could see an increase in the number of breakers who abuse other users and an added increase in those who use excessive power. So much so, that it could decrease everyone's chances of obtaining the more local copies, because of bleedover. It was also said that we would end up with more 'muppets' and become second in problems to Italy. Someone suggested that the DTI may have an ulterior motive in making known this suggestion and that they are unable to control the present problems. Furthermore, that if they allowed this 'open' system, they would decrease the number of users through creating more problems - and this would justify any future requests by the Government to 'do away with' certain CB frequencies.'

The official licence figures show that CB is on the decrease and the officials' interpretation of this is that there are fewer users. In fact, I would suggest that more users would buy a licence if they felt that the DTI were doing something to help clear away the muppets but they don't, so CBers won't shell out. Maybe there has been a drop in the original 1981 figures - but not *that* many. It is estimated through unofficial sources that the figures are around 200,000. So

the users are still there, Mr DTI. Out of interest, can anyone tell me what is meant by 'short range radio' as the UK Government says that CB radio was designed as a 'short range radio' communications system? That, to me, is like asking how long is a piece of string! Can anyone define it in actual distance miles? So what are your views on deregulation? Are you in favour or against?

Sometime before Christmas I was invited to attend a very 'special DX competition' by a breaker called Papa Papa 34 (Neil). These only take place every six months and it is by invitation only. DXers from all over the UK are picked through their addiction to DXing and they include those from UK FM, CEPT, 934 and AM/SSB. These are then dwindled down to around 24 users (because of space) and the invitations are sent out. The committee of five meet the competitors at an arranged place and at a set time, where everyone moves off to the 'official' DXing site, which is normally a very large piece of farm land (with the farmer's permission). At the site they are asked to pay between £2-£5 (competition entrance fee and towards a hot meal which is provided by the organisers) and then given a location to set up their situation. I was asked along as an observer but was warned that it was going to be a long and very hectic night. This turned out to be an understatement as it was clear that *all* of these breakers taking part were doing battle against each other to determine who was the best.

The site had been picked for its out-of-the-way position and the only access was down the farm road. The nearest main road was about a mile away and during our stay it was guarded by a couple of breakers in a car, who could alert the site should any official (DTI, police) take an interest. As the 24 stations set up, it became clear that they were all out to win. The list of rules are easy to understand and, apart from these, *anything goes*:

1. Any type of antenna is allowed, provided that it is no higher than 25 feet from the ground to its base. No more than three antennas to be erected at any one time per competitor.
2. The competition will start at 8pm and finish at 8am the following morning.
3. Any CB radio modes can be used.
4. Total output power on any mode must not exceed 25 watts.
5. Logs to be completed at the time of contact and handed to the organisers at the end of the contest.
6. Only contacts over 50-mile radius from the site and confirmed by QSL card (with its original envelope) will be used for the total amount of miles DXed. These QSL card confirmations must be sent to the organisers within 28 days of the event. These will be returned with a result sheet.
7. No QSL confirmations will be included

if they are not recorded on a log sheet.

8. QSL card confirmations can be sent to your own PO Box.

9. The winner will be the person with the furthest amount of confirmed DX miles and, in the case of a tie, the one with the most QSL confirmations (over 50-mile radius). Prizes for 1st, 2nd, 3rd, 4th & 5th (all trophies are to keep).

10. Only the person whose name is on the invitation can take part during the competition.

Competition Stewards will be on site at all times and you will be expected to allow them to check your power outputs at any time during the competition.

For the best part of the afternoon, everyone was busy setting up their stations, chatting between themselves and enjoying the chance to discuss many common distant contacts that they have made over the years. I was surprised that no-one complained about problems caused from other users on

the site – and this, I feel, was down to the expert planning of those in charge. As the night fell, you could hear distant CQDX calls and roger bleeps from all around and because of the expanse of land involved in housing these breakers away from each other, it took a good 40 minutes just to drive around the site. This farmer's land exceeded 200 acres and at one point he even made a visit to the site for a drink and a chat. It was a very enjoyable night and my thanks to everyone for the chance to witness a 'very special' DX competition. Perhaps one day I might get an invite to take part (hint, hint).

One or two of my amateur friends have made 'certain' comments about my open letter to the RSGB (January 89, *Cit' Band*) and, in doing so, have made it clear that they agree with the expressed sentiments. One even suggested that CBers should be allowed to keep the UK FM because "it allows the muppets to



Shepherd Man gets one in the eye from Hustler.



Left to right: Tony Jaconelli, David Tapper and Brian Babbington.

stay in one place." What do you think?

Well done to the Border Raiders DX Club who have, so far, raised around £500 to go towards charity (yet to be decided). Also to Breaker-Way Club who raised over £100 and the Kilo Tango Radio Club who raised over £140. Both of these were collected and are being sent on through Captain Beaky to help buy an electric wheelchair for a 10 year old girl, who suffered a major stroke before Christmas. Warminster Eagles DX Club also presented a cheque for £506.95 to the special Baby Care Unit at Oldstock Hospital, Salisbury, Wilts.

Two bad pieces of news. The first concerns a small number of 'CB louts' who are causing problems in the Nottingham area. These very uninteresting breakers have taken it upon themselves to travel the city by car and, amongst other things, pull breakers' antennae down. I have it on good authority that they wield clubs etc and they are possibly responsible for one or two breakers ending up in hospital. If you have any information, contact the local police. Or send it to me, and I will do it for you (without mentioning your name etc).

"CB louts are causing problems in the Nottingham area"

The second is about a breaker who has been visiting blind CBers in the Warwickshire area. This person is believed to have visited around 15 homes saying that he is a local RIS Officer, and taking away specially adapted sets. If you know of anyone living in this area who has been visited by this person or you have any information that may help the police, please contact them.

Although not a new CEPT set on the market, the Zodiac M-244 is claimed by

many to be the best on the market for the new frequencies. I was pleased to borrow a friend's Zodiac M-244 to carry out my own non-technical test. The set is around the same size as the UK FM Rotel 240, Uniden 200 and Harrier CBX although it is heavier. The case is of a blue, gun-metal colour and has four bracket mounting holes (two each side). The back has the usual standard features plus a socket for a selcall unit (when available) and the set's fuse (2 amp) which is externally accessible.

The front is well laid out with the mike socket connection to the bottom left-hand side. The channel selector is LED crystal instead of the usual LED light and it features an array of push buttons that take a lot of getting used to. Apart from the channel selector knob it has volume, squelch and mike gain knobs, as well as one marked 'A, normal, B,' which turns out to be a priority channel selector. In the 'A' position it goes straight onto channel 09. In the 'B' position it goes straight onto channel 40. I can understand the need for auto 09 but, why 40?

The six buttons on the front top right-hand side feature local/DX, NRC/off, PA/CB, Dim/Bright, DW/off and Scan/man. The local/DX button does take out the weaker stations when you really don't want to listen to them but I still prefer the old RF control, so it's a choice of either listening to all of the noise or not! The NRC/off reduces that unwanted noise that most people with tone facilities are able to do.

PA/CB is the same as on other already well used sets. In the 'Dim' position the Dim/Bright button lights both the channel indicator and the signal meter. However, when pushed onto the 'Bright' position it removes all the light from the channel indicator and into the signal meter. DW/Off allows the user to select any channel from 1 to 39 and with the 'A, normal, B' knob set in the 'B' position (and the squelch turned up) it will monitor the selected channel and the ch 40. The final button Scan/

Manual is just that. It goes through the full 40. For the set to scan each channel one by one, you have to turn the squelch control knob back into the 'Auto' position and leave the scan button in. It sounds very confusing and, until you master the controls, it is. To hold on to a channel whilst 'scanning' you just push in the PTT on the mike.

All in all it is a good set with some good features. However, the one I tested was very poor on modulation and I have been told that this model cannot be fitted with a power mike as it has a rig built in cancellation unit. This being so, it could lose out to other good value sets. Also the one that I tested was only pushing out 3.8 watts. Within the MPT specifications, but not what many breakers will want.

So, apart from having to shout into the mike, the only other things that I didn't like about the Zodiac M-244 was the way in which the selection of position 'B' on the 'A, normal, B' knob pushed you onto ch 40. I would have thought that, as this is a mobile rig, it would have been better with ch 19. And the way in which the Dim/Bright button draws off the light from both the channel indicator and signal meter into just the signal meter. This could prove to be a problem; you need a bright light on the signal meter and still want to see which channel you are on (ie whilst driving in the dark).

Once again, this year, I missed out on the New Years Honours List. However, so did many more deserving people than yours truly. Those that risk their lives day in and day out as well as those who give much of their time to helping others. In fact, the list read more like a *Who's Who* in the political support stakes than a list of the deserving. This Christmas and New Year has left its mark with one major disaster after another. CB and many of its users helped the emergency services with each of these. I know that CB was used to warn drivers of road problems as well as supporting in other areas. These varied from diverting traffic to making refreshments for the official emergency services, once again proving the need for CB radio in the UK.

A very worthwhile document from the DTI is 'The Radio User's Guide To The Law' (BR67) and it can be obtained from the Publications Dept' on 01-215 2072 (24-hr answer machine). They have managed to provide many answers to questions that relate to the use of radio equipment and explain some of the reasons why we need regulations. It lists what parts of the Wireless Telegraphy Act covers certain offences as well as explaining what the offences are listed under. I was very interested in the following statement: "On a world-wide basis the use of radio is regulated by the Radio Regulations agreed at meetings of the International Telecommunication Union. The Radio Regulations are legally binding on the Member States, which

include the UK." After reading this document, I am concerned that any future changes to the radio spectrum may be forced onto the UK by the majority of these Member States. But who are they and what power do they have to control the future? What is the extent of the power yielded by the International Telecommunications Union in legal terms and how would it be if the UK went against a majority of Member States? Maybe the DTI should consider publishing a document with details of just who these people are, what they control and how they function! There are other bodies such as this one that could do with some kind of explanation, many of whom are within the UK. Well, give it some thought, Mr DTI!

News from MSGB Ltd (Monitoring Service Great Britain Ltd). In December 1988 they published a document entitled "The Use Of The Radio Frequency Spectrum Above 30 Ghz." Royston Williams, the Company's Managing Director, says that this discussion document is by way of "comments and suggestions in reply to the DTI's own Green Paper printed in September 1988." Anyone who would like a copy should send 50p worth of stamps and include their own address to: MSGB Ltd, 6c Linden Gardens, Chiswick, London W4.

1988 was not a good year for me when it came to films used at CB functions. Yet another film went missing which included pictures from Sunrisers DX Eyeball, Southernness Eyeball, Stanmer Park and the 2LO Poppy Run. This time it was down to the company that makes the prints for *Cit' Band*. I have managed to find a few photographs of the Stanmer Park event back in 88. They were on another roll of film. Also, I include the photo of Maggie (Tartan Special). A picture of the three wise monkeys taken at a meeting: Tony Jaconelli (Chairman of SACBC), David Tapper (Vice President of Natcolcibar) and Brian Babington (President of Natcolcibar) these three together representing Scotland, Wales and England. And least of all, a picture of yours truly receiving the custard pie treatment from Jim (The Hustler) at his birthday celebration.

As you know, some months back *Citizens' Band* asked for information from you about problems on the new CEPT frequencies ie from pagers etc. Now, either not that many of you use the new frequency or not that many of you are bothered, as the amount of information received by the Editor was next to nothing. To those who did write in, Eamonn has asked me to pass on his thanks and to those who didn't bother, there is still time. One of those who bothered was the Border Raiders DX Club from Greta in Scotland. Their information and tape sent is worth a mention because a company in nearby Langholm, Dumfrireshire, has just installed

two wool-drying machines which emits a signal on 27.125MHz. This causes a 30+ carrier to those living close by and the signal can still be recorded up to eight miles away. According to the DTI (Scottish RIS), there is a 'machine frequency' allocation between 26.957-27.283MHz. The machines use a radio frequency converted into heat to dry the wool.

From the tape that I was loaned, it seems that the RIS have carried out tests, and the machines are within the legal requirements. However, the RIS Officer made one or two sweeping statements which again point to the fact that CBers are not protected and as such they should not complain. It was pointed out by the club representatives that this carrier wanders and, at certain times, it has been known to wipe out up to 25 channels. The reply to this was



At last, the infamous Maggie.

'that still leaves 55 channels that you can use.' My thanks to George (BR 02), for the information and everything has been passed on to an organisation who will be in touch. If you have problems like this one write in to *Cit' Band* because you never know, someone may be able to offer advice or direct help.

How many have wondered why we are subject to gaps within the CB frequency bands, and how many know the true reason? The answer can be found in the MPT 1346 (April 1988) Performance Specification. This covers 'Transmitters and receivers for telemetry and telecommand devices operating at 26.995, 27.045, 27.095, 27.145 and 27.195MHz.' These very low powered

devices should not interfere with CB transmissions, according to the MPT specifications.

Under the notes heading 'General' they make the following statement as the specs definition: "For the purpose of this specification 'telemetry' and 'telecommand' are as defined in the Radio Regulations. 'Telemetry' is the use of telecommunication for automatically indicating or recording measurements at a distance from the measuring instrument. 'Telecommand' is the use of telecommunication for the transmission of signals to indicate, modify or terminate functions of equipment at a distance." Anyone who would like a copy can request one by telephoning the DTI Publications Dept on 01-215 2072.

An interesting idea has been sent to me from an amateur user who I know well, and I can assure you that he is very active in his support for CB. However, he has asked that he remains un-named at this stage - but I still feel sure that his thoughts will provoke CBers into penning answers to this magazine in the future. See what you think!

Facilities to Assist Organising a CB Public Service

One of the most useful facilities to help public service organisers is access to an up-to-date Licence List with names and addresses (or nearest postal town). This information is already held by the licensing authorities in every country and in the case of radio amateurs this is made available direct to licencees in the form of a 'Call Book' published at least once a year. This information is of great importance to enable mail shots and/or other contacts to be made when forming local clubs and/or area public service groups.

There might naturally be some reluctance from many licensees to allow their addresses to be published and this can usually be overcome by only publishing the town or local area of residence and not the address in full. In addition, the Data Protection Act requires the licence application form to state that information given will be published and to give a choice for the applicant to sign whether his/her address can be used or his/her local town or area, in any publication.

Even the Russian Government who would never publish anything, has now indicated that USSR radio amateurs will now be free to have their own 'Call Book' published and, to be able to QSL direct by post and not just via an official PO Box number in Moscow.

It makes sense that since CBers supply their details for the licence and pay for the admin cost of collating the details for the licence system, that they should also get the advantage of access

to it, for their own organisational purposes. Since one of the greatest problems of CB is in putting over its points and getting proper public recognition of its capabilities and its sometimes weak organisation locally as well as the general poor co-ordination between groups and areas, serious consideration should be given to discussing this necessity.

If one considers the massive numbers of CB licences in Europe alone, then 'Licence List Books' published in each European country would give a vital database accessible to national CB groups, local clubs and CB public service groups for planning and organising all sorts of events. Many local clubs can organise using their own membership lists but this tends to be limited to CBers who are already members and does not give full access to other new licensees who are potentially new club members, or are emergency public service operators etc.

Any future UK systems including SSB would include ATIS, and this will, in effect, be a form of 'call sign' or 'ident number' unique to each licensee in the country and a start could be made by requesting an SSB CB Callbook to be made available concurrent with the starting of the CB SSB licensing system. In fact, it should be a condition of the SSB CB system that licensees collectively will have access to *their own* licensing information, published annually to start with.

It is highly likely that the effect of such regularly published 'Licence List' books will greatly increase the number of CB licences and thus improve CBers' ability to negotiate with the DTI. The ability of CB to access and organise its potential strength in many areas will then be greatly increased.

CB at present must be the only public

communications system that has 'no' directory of its users which is what a Licence List is. What use would a telephone, telex or postal system be, if no directory or address lists were available? If such a CB Directory were available and published either by or in co-ordination with national CB groups, CB public service groups or possibly through CB magazine, then other useful information like club and public service organisation membership as well as contact telephone numbers could be

"Maybe the SSB system would be the favourite mode of transmission . . ."

given. Some Amateur Radio Call Books allow licensees to send in their own personalised entry, so that they can add things such as interests, hobbies etc, provided that it fits into the limited entry space and this may involve a nominal fee.

Provided that an agreement can be reached on the need for a CB Directory in the UK then a general point, together with an explanation of the organisational advantages for CB should be given to the European body for CB ie the ECBF. With the backing of the European CBers, we could encourage proper organisation between large numbers of CB groups both in a local and national capacity, and in particular for 'Public Service.'

I am aware that amateur users were very much involved with the earthquake in Armenia before Christmas, inasmuch as they helped to pass third party information, and that the Russian Government gave permission for amateurs from both the UK and America to help set up vital links in Armenia. A small party of amateurs were invited by

the Russians to set up these stations close to the main devastated area and work alongside USSR amateurs, government officials and rescue services. In fact, the amateurs had already set a good precedent with their work in Mexico during and after that disaster. And in view of the more local CB links throughout the UK, the way in which many already work together (and given the three disaster situations in December and January) it could very well be time for some sort of action by way of a 'National List' of contacts willing to assist in various areas.' Maybe the SSB system would be the favourite mode of transmission during a national disaster. It would mean less chances of those involved suffering from the 'muppets' and it would allow for greater distances to be covered! What do you think?

Before I finish for this month I would just like to mention The Muddler (Dave) Chairman of the Warminster Eagles and the never-ending saga of his Skoda (sardine tin with wheels). It seems that he is going to have a 'car telephone' installed in it. Nice one Dave, but I didn't think that British Telecom installed 'payphones' in cars - or is it a 'phonecard' one?

For some time now, I have been receiving 'Earwig' news magazine which is put together and published by Gizmo (Kath). It is printed monthly and costs 20p per issue. Lots of advertising, news, event dates and other information. The address for the publication is: Earwig, PO Box 13, Warminster, Wiltshire. And thanks to her I would like to leave you with this thought for the next time that you ask for "A Day Off!" So you want a day off. Let's take a look at what you are asking for. There are 365 days per year available for working. There are 52 weeks per year in which you already have two days off per week, leaving 261 days available for work. Since you spend 12 hours each day away from work, you have used up 170 days, leaving only 91 days available. You spend 30 minutes each day on a coffee break and that accounts for 23 days each year, this leaves only 68 days. With a one-hour lunch break each day, you have used up another 46 days, this leaves only 22 days available for work. You normally spend two days per year on sick leave. Thus leaving 20 days available for work. We are off for five days holidays per year, so your available working time is down to 15 days. We generously give you 14 days vacation per year which leaves only one day available for work and I'll be damned if you're going to take that day off!

Please remember to send in some information about CBers, clubs, dates of events and funny stories. And remember that if you don't send in the information, then it won't get printed. Send the details to: Shepherd Man c/o PO Box 429, London, SW19 2UU.



CB4 The Blind, Stanmer Park.

EVERYTHING!

For the CB & Amateur Radio Enthusiast
from
Zetagi

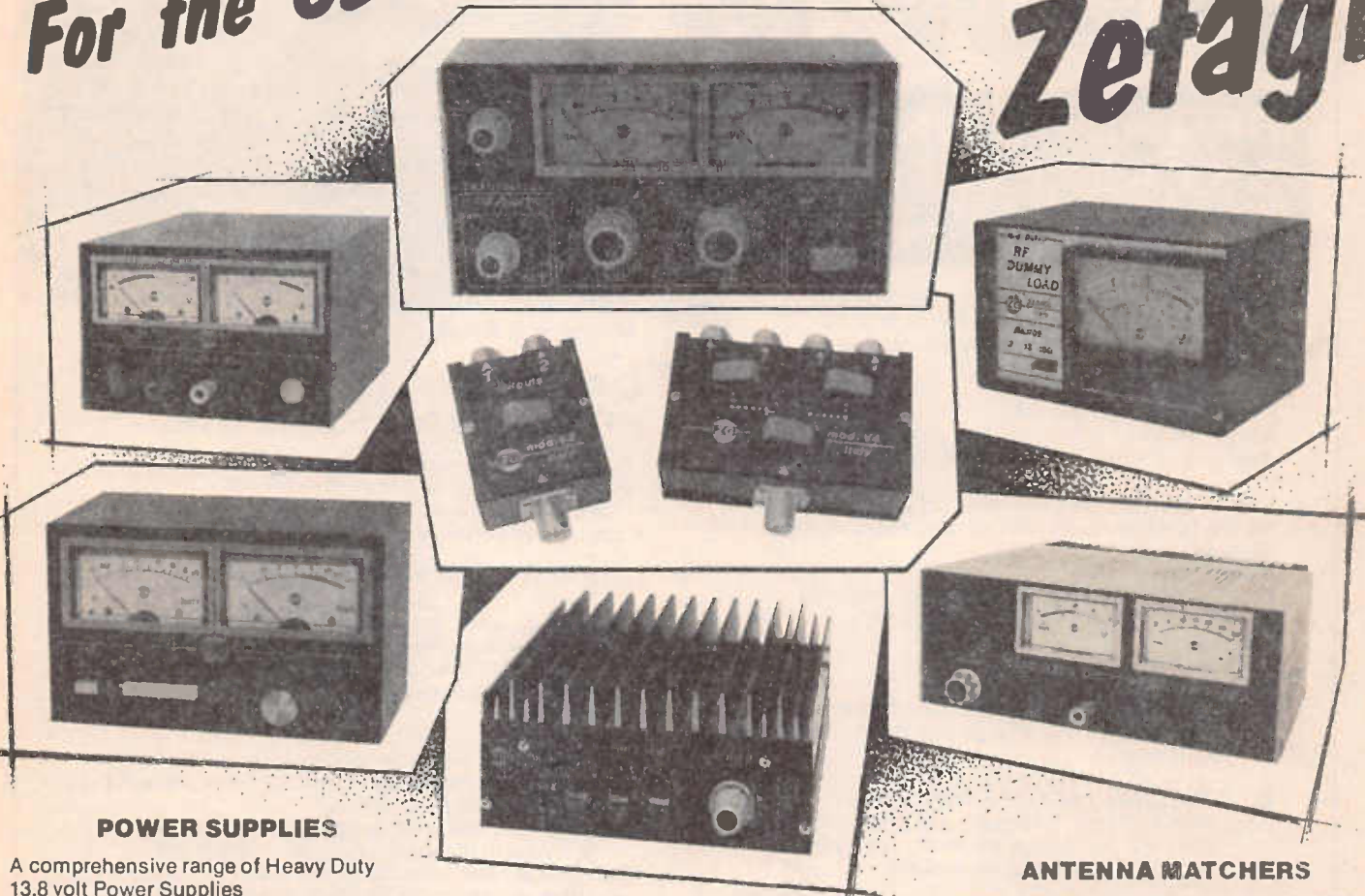

POWER SUPPLIES

A comprehensive range of Heavy Duty 13.8 volt Power Supplies

- MODEL 1210/1 10 Amp (No Meter)..... £69.95
- MODEL 1210/S 12 Amp (W/Meter)..... £89.95
- MODEL 1220/S 25 Amp (W/Meter)..... £149.95
- MODEL 1220/1 25 Amp (No Meter)... £125.00
- MODEL 1240/S 40 Amp (W/Meter).... £199.00

SWR/POWER METERS

Superb High Specifications for the discerning enthusiast. Just released.

- MODEL HP201 (3-300MHz) 1Kw Max . £29.95
- MODEL HP202 (26-30MHz) 1Kw Max . £39.95

PRE-AMPLIFIERS

Low noise - High Performance to improve reception on even the best receivers in the 26-30MHz range.

- MODEL HP28 Deluxe V/Gain..... £34.95
- MODEL P27-1 Base Station Pre-Amp. £25.69
- MODEL P27-M Mobile Pre-Amp £19.99

SWITCHES

A selection of Heavy Duty Low Loss Switches for frequencies up to 500MHz.

- MODEL V2 2 Way 500 Watt..... £6.99
- MODEL V3 3 Way 1Kw..... £15.00
- MODEL V4 4 Way 500 Watt..... £11.52

ZETAGI Products are available from specially selected dealers throughout the U.K. or direct from UK Importers:—

MOBILE AMPLIFIERS

ZETAGI are famous for their range of reliable and high specification Amplifiers — note these are for use by radio amateurs only and are not legal for CB use.

- MODEL B150 150 Watt (26-30MHz) £54.95
- MODEL B300 400 Watt (3-30MHz) .. £145.95
- MODEL B550 500 Watt (3-30MHz) .. £237.00

BASE AMPLIFIERS

Two popular models for use by radio amateurs. These are not legal for use on CB radio.

- MODEL BV131
A valve Amplifier covering (26-30MHz) and delivering 100 Watt output £115
- MODEL BV132
A Solid State Broadband (3-30MHz) Amplifier delivery 100 Watts £125

FREQUENCY COUNTERS

- C45 5 Digit Compact counter
Ideal for use up to 50MHz £59.95
- C357 7 Digit Top of the range
For use up to 350MHz £99.00

ANTENNA MATCHERS

- MM27 100 Watt (26-30MHz)..... £11.95
- M27 500 Watt (26-30MHz) £19.95
- TM1000 1Kw matcher and 2 way switch with SWR/PWR meter £67.00

DUMMY LOADS

- DL150 A superb precision Dummy Load and Power meter.
Freq: 3-500MHz
Power: 1Kw £88.00
- DL50 50 Watt 500MHz Load £13.50

METERS

- Top Class Precision Instruments for the Service Dept. or Radio Amateur.
- MODEL 430 A VHF SWR and Power Meter
Freq: 120-500MHz. Power 1Kw £69.50
- MODEL 700 A combined VHF and UHF Precision Meter. Freq: 120-500MHz
Freq: 120-150MHz Power: 1Kw (Max) £99.95

We also carry the complete range of Zetagi Spares.

CATALOGUES

SEND IN NOW £2 FOR OUR BUMPER PACK OF CATALOGUES AND RECEIVE £20 WORTH OF VOUCHERS. PACKED FULL OF USEFUL TECHNICAL INFO AND DETAILS OF ALL OUR PRODUCT RANGES

NEVADA

189 LONDON ROAD NORTH END PORTSMOUTH PO2 9AE

HOTLINE (0705) 662145

FIND LOVE WITH

dataLink

**BRITAIN'S FOREMOST
& LEAST EXPENSIVE**

NATIONAL COMPUTER DATING AGENCY

NO MATTER *where* you live, or *who* you are, DATALINK is able to find you ample LOCAL introductions ... all *personally* selected by our experienced Staff.



LAST YEAR, Datalink spent more on National Press Advertising --to guarantee you *partners near-home*-- than any other Agency in GREAT BRITAIN.

FOR DATALINK does not cater only --or even largely-- for the London Area ... but for the whole of the British Isles.

THAT'S WHY Datalink is large ... so obviously successful ... so competitive ... and so up-to-date

Look at the facts:

- Our STAFF SELECT your Introductions themselves --not a large *automatic* mainframe computer.
- Our STAFF CHOOSE LOCAL contacts ... often on your doorstep. (We don't use *mini-maps* of Britain ... with large squares ... covering *huge* areas --for you to 'draw around'.
- AND significantly

ONLY DATALINK GUARANTEE MEMBERS AT LEAST THREE SUITABLE CONTACTS IMMEDIATELY
--- or refunds fees in full by return!
(Usually you will receive six!).



Michele & Brian (Brighton)

DATALINK IS A UNIQUE PERSONAL SERVICE...

Our system is unique because our STAFF --not machines --make all the final decisions ...
...We didn't *invent* computer dating ...an *American* did ...but we've certainly improved *and modernised* it.

AND NOW another First! WE NOW HAVE A GOLD SERVICE

...Whether work, studies, or divorce keep you out of the social scene longer than expected ...we have something SPECIAL just for you. (All details are sent along with Brochures)

PUT SIMPLY ...

DATALINK is a veritable National Institution ...widely respected everywhere for its honesty and integrity...
...AND ITS FRIENDLY SERVICE!

We take the hard work out of meeting people, and have a wealth of 'know-how', second to none.
You needn't live near Datalink. Quite the contrary... whether you reside in Northern Ireland, the Isle of Man, John O Groats or possibly at Lands End, we are simply a phone call from you ...ALL DAY ...even AFTER WORK --till 10.00 pm.,
We, at Datalink, are here for YOUR Service and YOUR convenience.....
.....Don't settle for less!

**DATALINK P. O. BOX 100
STRATFORD-UPON-AVON CV37 6LE**

FREE COMPUTER TEST

In less than ten years nearly one million people have completed our Questionnaires. Why not fill in this simple version. We will send you FREE and in COMPLETE CONFIDENCE full information about Datalink AND details of just ONE OF THE MANY Datalink Members who we feel you would like to meet.
Please process the completed Questionnaire, send me full information on Datalink, AND details of someone you believe will be compatible. I understand that this is FREE and WITHOUT OBLIGATION

I am over 17.

START HERE

YOUR PERSONALITY:

F85

Occupation _____
Nationality _____
Your Sex (M/F) _____
Your Height _____ Your Age _____
Age range of person you wish to meet
Minimum _____ Maximum _____
Surname _____
First Name _____
Address _____

Are You

<input type="checkbox"/> Shy	<input type="checkbox"/> Outgoing
<input type="checkbox"/> Nervous	<input type="checkbox"/> Self-Confident
<input type="checkbox"/> Affectionate	<input type="checkbox"/> Fun Loving
<input type="checkbox"/> Romantic	<input type="checkbox"/> Ambitious
<input type="checkbox"/> Intellectual	<input type="checkbox"/> Creative
<input type="checkbox"/> Tolerant	<input type="checkbox"/> Generous

YOUR INTERESTS AND ACTIVITIES

If you enjoy any of the following please ✓ tick if you have particular dislikes please indicate with a X cross. Otherwise leave blank

<input type="checkbox"/> Pop Music	<input type="checkbox"/> Classical Music
<input type="checkbox"/> Pub Evenings	<input type="checkbox"/> Dancing
<input type="checkbox"/> Dining Out	<input type="checkbox"/> Collecting Things
<input type="checkbox"/> Travelling	<input type="checkbox"/> Spectator Sport
<input type="checkbox"/> Theatre/Cinema	<input type="checkbox"/> Poetry/Reading
<input type="checkbox"/> Walking/Cycling	<input type="checkbox"/> Gardening
<input type="checkbox"/> Committee Work	<input type="checkbox"/> Conversation
<input type="checkbox"/> Watching TV	<input type="checkbox"/> Museum visits

Please enclose 2 First Class Stamps

For Brochure by return post, phone (0789) 750092. (24-hr Reply Service)
DATALINK: POST BOX 100, STRATFORD-UPON-AVON CV37 6LE.

dataLink

MODUS OPERANDI

Brian Kendal takes a look at the various models of transmission

Since the dawn of CB operation, there has been a continuing discussion as to the efficiency of the various modes of operation. The protagonists of FM, AM and SSB have all put forward powerful arguments for the adoption of their beliefs. However, despite their vehemence, few seem to really understand the technical nature of the various modes of transmission commonly used by the international CB community.

It is well known that there are three types of transmission available: Frequency Modulation; Amplitude Modulation and Single Sideband, of which only the first is legal in the United Kingdom. It would therefore seem appropriate to start with a description of

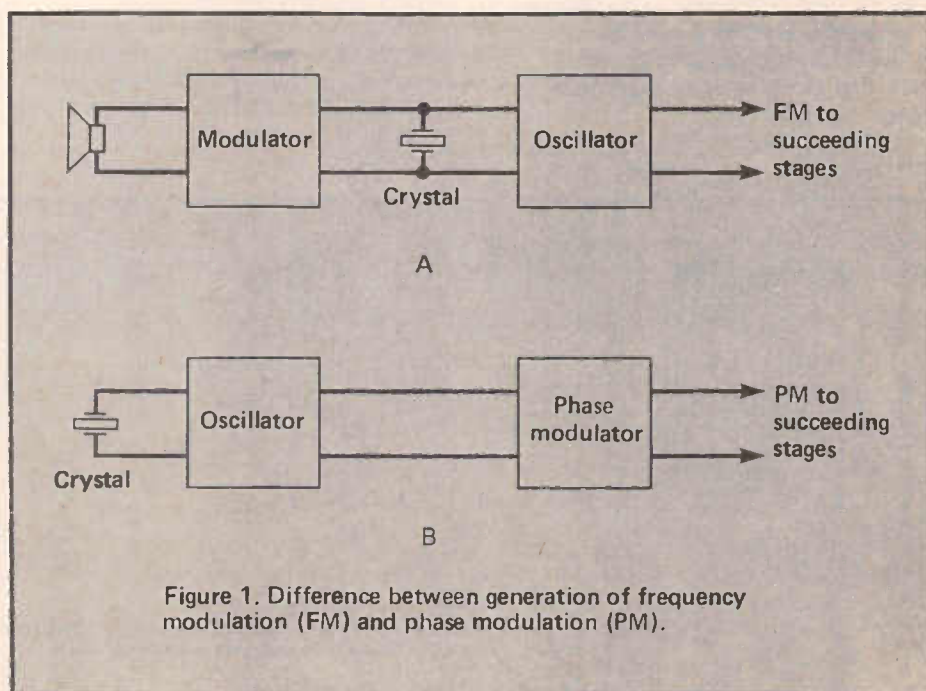

Figure 1. Difference between generation of frequency modulation (FM) and phase modulation (PM).

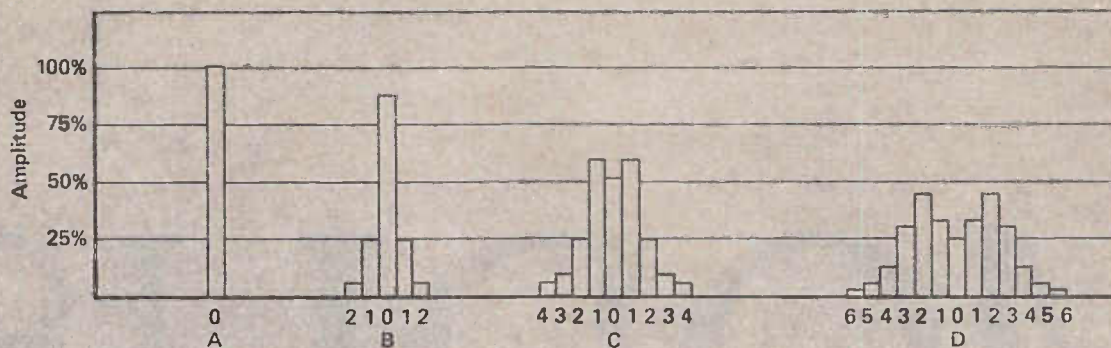

Figure 2. Relative carrier sideband power for various modulation levels of an FM transmission
 A: No modulation B: Level suitable for 10kHz channel spacing C & D: effect of overmodulating
 Note that if the modulating frequency were 4kHz, D would be spreading +24kHz
 i.e. blocking 3 channels on either side of the working channel.

that mode of operation.

Frequency Modulation

Although the mode of operation of legal CB in the United Kingdom is commonly called "Frequency Modulation," this is, in fact, a misnomer, for the correct term is "Narrow Band Frequency Modulation." Furthermore, in most cases the transmitters do not radiate frequency modulation (FM) at all, but phase modulation (PM). The authorities get round this problem by using the generic term "angle modulated" which applies equally to both.

The difference between the two systems is that in FM, the modulation is applied directly to the oscillator, which produces a direct frequency shift of the carrier, while in PM the modulation is applied after the oscillator and modulates the phase of the transmission rather than its frequency. The overall effect is very similar and, at the receiver, it is doubtful whether any difference would be noticed. The PM system is more commonly used for reasons of design convenience.

If a transmission is either FM or PM modulated with, say, a single tone of

1000Hz, then sidebands will be produced at 1000Hz intervals to infinity on either side of the carrier frequency. If the level of the modulation is low, then the energy output beyond the second or third sideband is likely to be insignificant, however, as the level of modulation is increased, the strength of the carrier decreases somewhat while that of the sidebands increase to the point where they far exceed the carrier. The higher sidebands may then become sufficiently strong to cause serious interference to adjacent channels in the extreme case, it is possible for an extremely badly adjusted CB transmission to block the whole waveband over a significant geographical area.

The advantage of FM over the alternative modulation systems is twofold. Firstly any signal of reasonable strength will be received against a quiet background and, secondly, any interfering signal, unless of very similar strength to the wanted transmission, will be totally inaudible. This is known as the "capture" effect and how effective this is is largely a measure of receiver performance.

These characteristics are possible because the modulation is only of the frequency (or phase) of the carrier wave. A well designed receiver will not respond to any amplitude modulated signal. Consequently noise, such as ignition interference or even the normal atmospheric background, which is, in effect, amplitude, should be inaudible.

Furthermore, if another FM signal is received on the same frequency as the wanted signal, the two will beat together, but as the heterodyne note is effectively an amplitude modulated transmission, the FM demodulator will reject this and the louder signal will be heard without interference.

This effect is achieved because the demodulator of an FM receiver is essentially a two part device.

In the receiver, the signal enters at the aerial terminal where it is first amplified and then frequency converted to a second frequency (known as the intermediate frequency), where it is further amplified to a level sufficient to drive the first selection of the demodulator.

This is known as the "limiter" and its purpose is to restrict all incoming

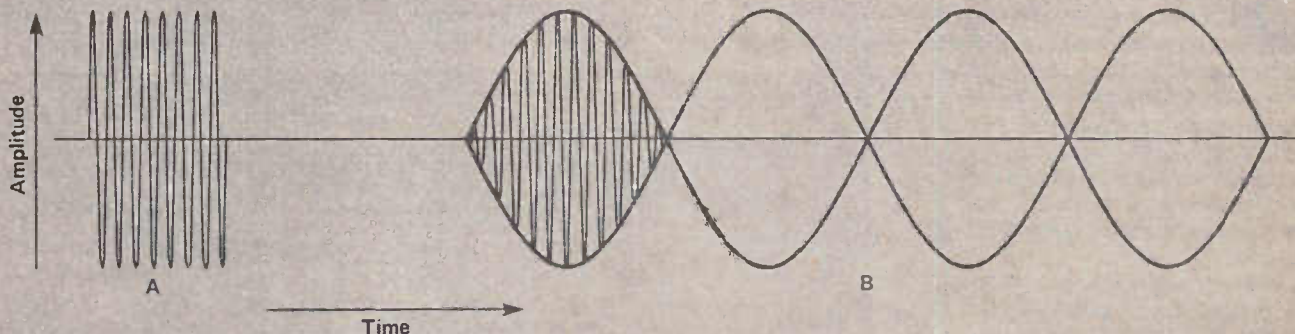

Figure 3. Normal representation of a carrier wave, amplitude modulated by a single tone. A: unmodulated B: modulated

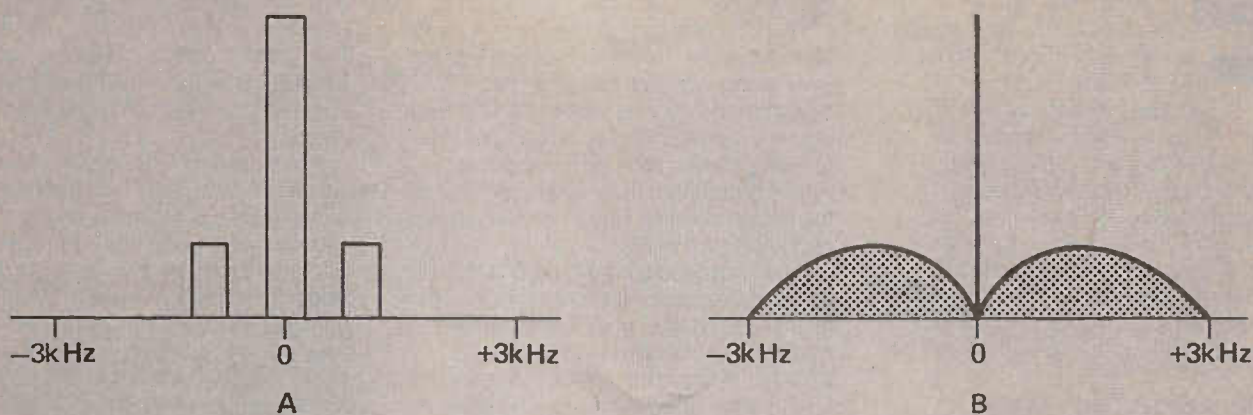

Figure 4. Spectrum of an amplitude modulated (AM) transmission. A: Single tone modulation at about 1kHz B: Modulated by speech. Compare with the requirements as shown in Figure 2.

signals to the same level, whether they be S9 plus or on the threshold of audibility. The efficiency of the limiter stage has a very great effect on the ability of the receiver both to provide a quiet background for receiving or to reject weaker signals on the channel.

With all incoming signals at the same level, the output of the limiter stage is fed to the discriminator which converts the frequency modulation to an audio signal. Unfortunately most discriminator designs are also sensitive to amplitude modulation to a lesser or greater degree, thus the design of the preceding stage is of vital importance to the overall efficiency of the equipment.

If, however, a signal is not sufficiently strong to cause the limiter to operate, the discriminator will demodulate both the incoming FM signal and the AM component of the noise and the signal will be heard with a noisy background.

Amplitude Modulation

Until a few years ago, the only form of speech modulation used for radio transmission was amplitude modulation (AM). Despite the fact that both alternative modes had been invented in the 1920s, it was not until the 1950s that experiments were carried out using FM for high quality broadcast and SSB for long distance communications.

It should therefore not be surprising that, when CB was introduced into the United States soon after WWII, amplitude modulation should be used.

In the most simplistic terms, amplitude modulation may be described as "impressing" a speech waveform on top of a carrier wave causing it to vary in level with sympathy with the modulation.

In the receiver, the carrier wave is demodulated by rectification thus recovering the original speech waveform.

Such theory can be "proved" by first showing a carrier wave on an oscilloscope and then applying a tone modulation when the strength of the carrier wave will be seen to be varying in sympathy with the modulating signal.

This, however, in common with most other simplistic explanations is inaccurate, for modulation is frequency mixing process with exactly the same characteristics as the frequency changer in a receiver.

In order to understand this process, think first of two signals whose frequencies are F_1 and F_2 . If these are both introduced into a non-linear circuit, they will beat together and produce two further signals whose frequencies are $(F_1 + F_2)$ and $(F_1 - F_2)$ as well as the original frequencies.

To make this a little clearer, let us take an example in which F_1 is 10MHz and F_2 is 6MHz.

The output from the mixer will be the original frequency 10 and 6MHz, plus two new frequencies which have been generated in the mixing process: 16MHz ($F_1 + F_2$) and 4MHz ($F_1 - F_2$).

At this point the reader might, quite reasonably ask how this applies to the action of modulation. Earlier in this section it was said that if two frequencies were introduced into a non-linear circuit, a mixing action would take place. The modulated stage of an AM transmitter is invariably extremely non-linear and, consequently, when an additional speech waveform is applied, the mixing action will take place.

Thus if a transmitter operating on a frequency of, say, 10MHz is amplitude modulated with a single tone of 1kHz, then the output will contain; 10MHz (the carrier frequency); 10.001 MHz ($F_1 + F_2$) and 9.999MHz ($F_1 - F_2$), the last two being known as the sideband frequencies. The original 1kHz will not

appear in the output merely because the tuned circuits for 10MHz would not pass it.

These sidebands can be seen quite easily on a device known as a spectrum analyser. This is a type of oscilloscope which displays signal strength vertically and frequency horizontally. The effect may also be demonstrated on a selective communications receiver on which the carrier and each of the sidebands can be separately resolved.

How, therefore, does a normal oscilloscope show the carrier varying in strength with modulation? The reason for this is that a normal oscilloscope displays the overall level of the signals applied to its input with respect to time whereas the spectrum analyser displays the level with respect to frequency.

If the power in the sidebands is algebraically added to that in the carrier the resultant waveform will be as indicated on a normal oscilloscope display.

The amount of audio modulation impressed on the carrier wave is known as the modulation depth and the point at which the algebraic sum of carrier and sideband power will swing from zero to double the carrier power is considered 100% modulation. Should the modulation be increased above this, the RF output will be completely cut off for a period of the modulation cycle and this will cause interference in the form of splatter to be radiated on adjacent frequencies.

This effect can be seen quite easily on an oscilloscope, for when excessive modulation is applied, the pattern will show the breaks in the carrier.

Next month, we shall be looking at Single Sideband transmission and comparing the relative efficiencies of the three modes.

For some time now a selection of CB user groups have been invited to meet the DTI and discuss certain matters, as well as receive information. These meetings take place about every six months and help to form the basis of a close relationship which ensures that the CB user is not forgotten. Each of these DTI-selected groups are then expected to report back to the CB users of the UK items on the agenda, as well as inject the thoughts and wishes of the CBer.

As you would expect with any Government building, Waterloo Bridge House is security-conscious, with passes issued on the way in and an escort up into the meeting room. Notices are very evident throughout the building which proclaim that you are entering a 'green,' 'red' or 'yellow' section. And even though you are made to feel at ease, it could, it some, feel like 'Daniel entering the lions' den.' As with other well-planned meetings, everyone present is given an agenda which has been known to include points pre-sent by those present and, like most meetings, it is not always easy to stick to

the agenda.

The Chairperson for this meeting was Mrs Kate Allan from the Licence Section who, along with five other various department Officers, faced the 12 CBers present representing seven groups. The meeting started with an around-the-table introduction from all present before the actual meeting began on the subject of 'The Future of CB.'

It was made clear that the DTI has no plans to take away the present UK FM (27/81) but that it would be expected that they would have to take into account the number of licences issued for CB when the Spectrum is reviewed in 1990. They showed concern at the declining figures and made it known that they do intend to carry out some form of monitoring programme to ascertain the frequency usage. ABCB explained that they had carried out their own monitoring programme in the Nottingham area, and this had shown that usage of UK FM was higher than any official figures and yet users of the CEPT frequencies had decreased.

Natcolcibar asked about the problems on CEPT from pagers and asked if these pagers were allowed to send out a 'continuous' carrier. The DTI answered

that the pagers will be allowed to continue on this frequency until 1996. MSGB (VO) said that they had written to the RPA and that the RPA needed specific interference details from pagers.

The question of 80-channel sets was again raised but the DTI stated that this would cause problems with harmonisation with other European countries, that the MPT specifications does not allow for this, and that if this was allowed then should in the future they decide to withdraw 27/81, it could prove to be expensive for those who have purchased 80-channel sets. However, this was not aimed at any pre-empt for the 1990 Review. The DTI plan to start moving towards a 'reciprocal licence' agreement with other CEPT countries and that it would take time. The DTI also stated that they will resolve the situation with regards to the question of making $\frac{1}{2}$ and $\frac{3}{8}$ -wave antennae legal.

The DTI commended the SSB Proposal Document although they can see one or two problems. It was felt that to avoid interference problems the equipment would have to be of a very high standard, and this could prove to

QUESTION TIME

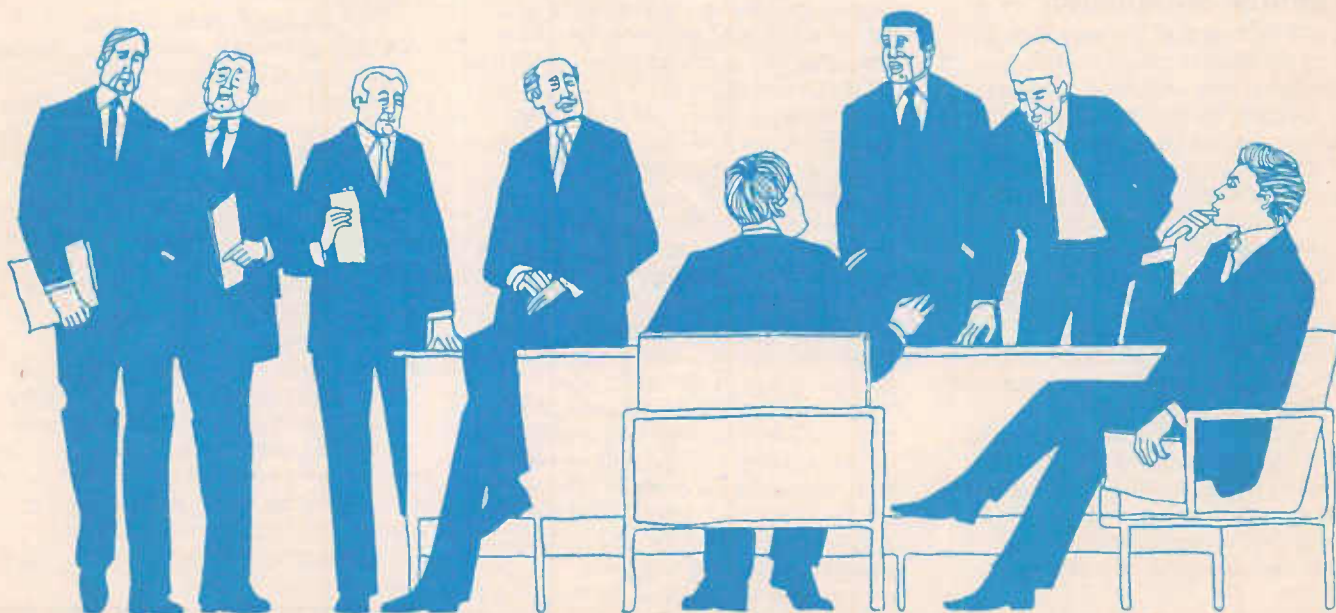

be expensive, that other present users of the frequency may suffer and that there is, at present, no MPT specification to cover SSB. MSGB (Ltd) said that it was the concept of an SSB system that was being asked for. Natcolcibar asked why it was that amateurs have the use of SSB and the DTI replied that they use it as laid down within the guidelines of their licence, which offers them the option to experiment. MSGB (VO) said that the intention was to encourage a workable system for both the user and the DTI, and that much interest has been shown for this idea, but that it is the actual 'proposal' that they are asking the DTI to consider.

ABCB put forward an idea for an intermediate/novice licence which could make use of more power on different modes without the user being knowledgeable on the piece-by-piece workings of a CB. Mrs Allan mentioned that the RSGB were working on such a licence but ABCB said that the context was totally different.

The question was raised with regards to 'back-chat' units being used in sets that are presently being used by radio users with special needs. The DTI asked for help in resolving this problem because, at present, those who use sets fitted with such units are outside of the MPT specifications, and were therefore breaking the law. They added that they are very concerned that these specialist users should not suffer and asked for a radio fitted with such a unit including a components list be submitted for testing and, hopefully, approval. MSGB (VO) said that they would submit a set in the near future. The DTI added that, because of their concern for these special need users, they would arrange for a temporary concession to be granted for the continued use of sets fitted with these units and that RIS officers would not confiscate them, subject to an approval being granted. It

was made clear that this concession would only cover the back-chat units and not any other CB add-ons. User groups have been asked to pass on details of this agreement to the users of CB radio.

Short Range Radio will be licensed in 1990 and the DTI confirmed that the MPT 1321 will be withdrawn at the end of 1988; they do not intend to relocate the present 934 users. The 934MHz Club expressed its regrets at the withdrawal of the MPT 1321 and asked if the present antenna restrictions could be relaxed. In reply, the DTI stated that, at present, the antenna restrictions have helped to stop problems to other radio spectrum users; however, if they did take away these restrictions, this situation may well change. MSGB (Ltd) asked if this new SRR system would be single or dual frequency. The answer was 'single.' PRCGB asked for confirmation to the users whether or not the SRR system is a variant of the 934MHz system. The DTI replied that SRR is not a substitute for 934MHz, as SRR is aimed at the business end of the market.

Enforcement campaigns by the RIS have been moving around the country, district by district, and the DTI claims that CB is on the decline by both licensed and unlicensed users. From the results shown by the report given to those present, the DTI have carried out random frequency usage checks in specific areas. MSGB (VO) questioned the results of the report in question, and the DTI have agreed to re-check all of its details.

The RIS plan to step up its campaign against those who flaunt the laws governing the use of CB radio and in particular where users do not hold a current licence. ABCB stated that it is the lack of policing that is causing the decline in licence figures as the users feel that they are getting nothing in return for their £12 fee. Natcolcibar

asked for more attention to be paid to certain taxi and minicab companies who still only use one licence to cover their employees. The DTI have asked for any information on this matter.

The RIS made it clear that it is very costly to the DTI to investigate an offender, as this involves monitoring his or her activities, which often called for overtime payments to Officers. Therefore, the RIS have to ensure that each case shows justification and a good chance of a successful prosecution. ABCB suggested that in certain continual offenders' cases, the DTI should revoke any future applications for a CB radio licence, and further felt that more publicity should be given to court cases of offenders, and that this information should be given to the press by the DTI. The DTI said that they will issue statistics as from February 1989. These will then be issued on a regular basis.

Much of the revenue paid in from licences, both new and by re-issue, is lost to the Post Office in handling charges, the DTI claimed, and they are currently considering other methods of payment. It could be said that if this loss in revenue could be decreased, it may well offer a better service to CB radio users. The DTI will look into suggested ways of changing the present licensing system.

The question of electro-magnetic compatibility was discussed and the DTI stated that the EMC directive would be sent to the groups present for further information. The DTI brought up the subject of de-regulation and the groups present felt that if this was brought about the RIS involvement towards CB would become less, and in this kind of situation we would have no redress. The DTI stated that they are now allowing sellcall to be used within the CEPT frequencies, and that they will alter the licensing conditions booklet etc to cover this point.

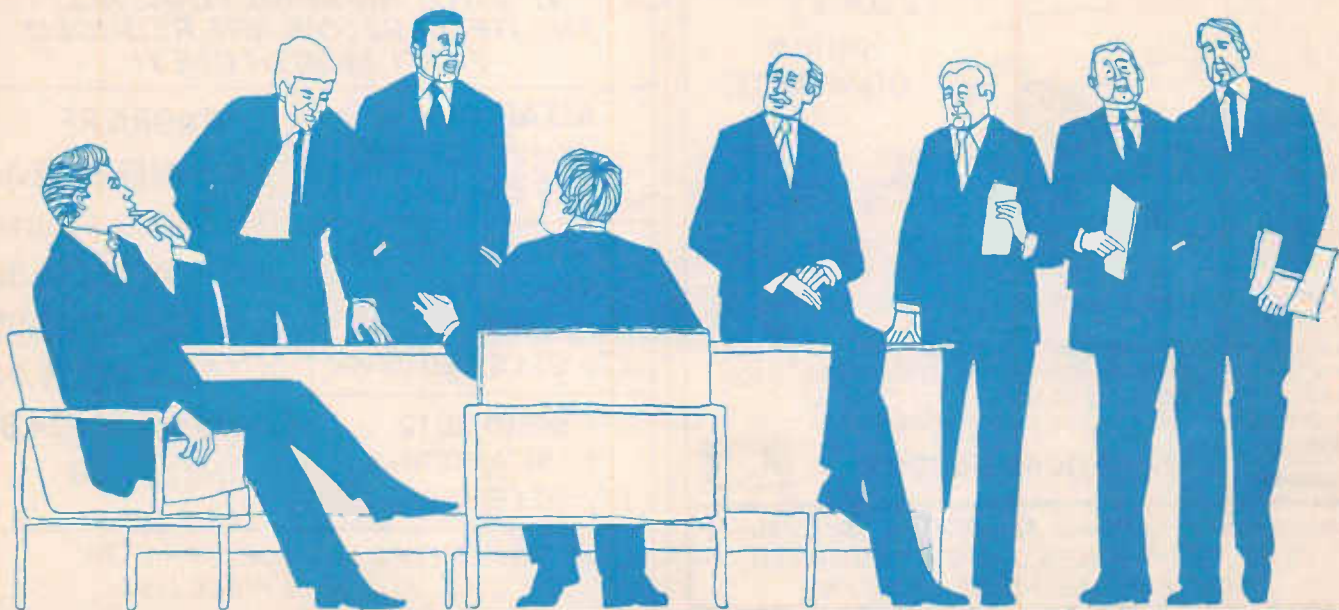

ACCESSORIES

WHOLESALE

CB radios, aerials and accessories delivered to your shop. Contact for price list.

Pama House, 433 Wilmslow Road, Manchester M20 9AF. only 3 minutes from M56



OPEN EVERY DAY, SUNDAY 10-2

NATIONWIDE DELIVERY DEALERS

contact us today for very fast, friendly service, competitive prices, widest range and latest CB products.

Tel: 061-446 2437 061-445 8918
061-434 5701
Telex: 666762 PAMAGO G
Fax: 061-445 0978
Order Line: 0800 262963



BREAKER BASES

BERKSHIRE

JONES RADIO

181a Oxford Road Reading, Berks. Tel: 0734 585416

Open: 9am-5.30pm. Mon.-Sat.

CORNWALL

RON'S SHOP

46 Lower Bore Street, Bodmin Cornwall PL31 2JY. Tel: Bodmin 0208 74569

CB RADIOS and all ACCESSORIES CORDLESS TELEPHONES and ANSWERING MACHINES, RADIOS, ELECTRICAL GOODS ETC

Open: Mon.-Sat. 9am-6pm

DEVON

AGRIMOTORS

Merton CB & Radio Centre Merton Garage & Post Office, Merton. Nr Oakhampton EX20 3DZ

Open 6 days 9-6 (Sundays by appointment)

Specialists in 934MHz Suppliers of all 27Mhz and 934Mhz equipment Tel: 08053-200

HAMPSHIRE

BREAKER'S WORLD

2 High Street, Bordon, Hants.

We are the experts in communication.

Full range of CB and accessories in stock.

Fully equipped workshop for repairs.

Open 7 days a week Mon-Sat 10am-6pm Sun 10am-1pm. 04203-4684

CAMBRIDGESHIRE

Tower Communication



Everything for the 27MHz & 934MHz CBer. Radio Amateur or SWL

* First Class Sales & Service * 11 High Street, Haddenham, Cambs. Tel: Ely (0353) 740306

CORNWALL

CHAT BACK CB CENTRE

FULL STOCKS OF 934MHZ & 27MHZ AMATEUR RADIO — PMR & NEW CEPT CORDLESS PHONES — REPAIRS

Opening Hours: Mon-Fri 9am-5pm Sat 9am-1pm

Easthill, Tuckingmill, Camborne, Cornwall TR14 8QL. Tel: 0209-715773

DORSET

WEYMOUTH OPEN CHANNEL

27 & 934MHz

Extensive stock always available + computer repairs

Also phone equipment

& computer software

Open 10-5.30 Mon-Sat

Telephone enquiries & mail order welcome.

91A Chickerell Road, Weymouth, Dorset Telephone: 0305-787777

HAMPSHIRE

P. SQUIRE (ANDOVER) LTD.

19 Bridge Street, ANDOVER, Hants

Tel: 0264-52623

SPECIALISTS IN CB SALES AND SERVICE

Very large selection of Rigs and Accessories.

Repairs, and Services Reasonable prices. Expert Advice — Free.

Open 8.30 to 5.30 (excl. Wed. & Sun.)

CHESHIRE

PENKETH ELECTRONICS & CB SUPPLIES

5 Chapel Road, Penketh, Warrington

We are the CB stockists for the Cheshire/Merseyside area. Sales & Service, Audio & Hi-Fi Accessories. Secondhand Hi-Fi bought and sold.

Telephone 092 572 3282 Open 9.30-5 (except Wed & Sun)

DEVON

CB SALES

We guarantee that if we have it in stock + you can find it cheaper locally, we'll match/better the price. Full repairs, modifications, services.

CB SALES, Stidson,

South Brent, Devon TQ10 9JT

Tel: 0364 73292 or 0364 73891

Open: 8.30-9.30 Monday to Sunday

Mail Order, telephone enquiries welcome.

ESSEX

WOODFORD CB CENTRE

528 Chigwell Road, Woodford Bridge, Woodford Green.

Tel: 01-504 9652

We offer a full repair service and rig conversions. We will match any genuine advertised price.

LARGE RANGE OF CB EQUIPMENT

Open Tues-Sat 10am-5pm

HERTFORSHIRE

934MHz 27MHz

Largest selection of CB Equipment

Mail Order Service

37-39 Station Road, Rickmansworth, Herts WD3 1QP

Tel: (0923) 775577/770634

Mon.-Sat. 9am-6pm

Wed 9am-1pm and 3pm-6pm

CHESHIRE

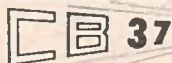

LARGEST STOCKIST OF NEW ANDS/HANDCB EQUIPMENT IN THE CREWE AREA

CB37

15 Middlewich Street Crewe CW1 4BS

Tel: 0270 588440 anytime

DEVON

MAGGIE'S C.B. CENTRE

Open: 10am-5pm.

Closed Wednesdays and Sundays.

Full repair service for all electronic equipment including both old/new frequency/rigs. Scanners, aerials, rigs etc. for sale.

63 Fleet Street, Keyham, Plymouth

Nr. HMS Drake PL2 2BU

Tel: Plymouth (0752) 563222

or workshop/answerphone (0752) 569237

GLOUCESTERSHIRE



CB SALES & SERVICE

COMPREHENSIVE RANGE.

COMPETITIVE PRICES.

OPEN: MON.-FRI. 9am-5pm

TELEPHONE & MAIL ORDER WELCOME

TEL: 045382 6710

SEND £1.00 FOR LATEST ILLUSTRATED CATALOGUE.

UNIT 38, UPPER MILLS, STONEHOUSE, GLOS.

JUNCTION 13 - M5

FIRST RIGHT PAST THE SHIP INN.

KENT

R G ELECTRONICS

For all your C.B. equipment

Established seven years

Open six days Mon - Sat

HP Terms available

For Mail Order Catalogue send two

19p stamps to 66 Oxford Street,

Whitstable, Kent CT5 1DG.

Tel: 0227 262319



WHOLESALE DISTRIBUTORS OF CB

Giant range of CBs and accessories, contact us today for very fast, friendly service, competitive prices, widest range and latest CB products.

Tel: 061-445 8918 061-434 5701
Telex: 666762 PAMACO G
Fax: 061-445 0978
Order Line: 0800 262963

WE DELIVER NATIONWIDE OPEN EVERY DAY, SUNDAY 10-2
Pama House, 433 Wilmslow Road, Manchester M20 9AF Only 3 minutes from M56
Tel: 061-446 2437



BREAKER BASES

KENT



1 St James's Road, Gravesend, Kent DA11 0HF.
Gravesend SE7171
FOR ALL YOUR COMMUNICATION REQUIREMENTS
CB, RADIOS, AMATEUR RADIO ACCESSORIES
installation & repairs
★ METAL DETECTORS ★
MAIL ORDER SERVICE
"communicate with confidence"

MIDDLESEX

CB EXCHANGE
For rigs, accessories, sales and service
Part exchange welcome

Tandy authorised dealers
475 STAINES RD., BEDFORD, MIDDLESEX (Nr. Barclays Bank) TW14 8BL
01-890 0800
WE RARELY CLOSE

SURREY

WALL TO WALL CB

154 London Road, Hackbridge, Surrey.
Tel: 01-647 4758

SURREY

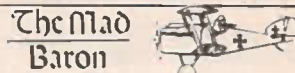

The CB Specialist
Rigs - Twigs and other Bits Supplied and Repaired
Phone BOB on (0932) 336010 (24 Hour Answer phone)
WILL MAIL AT COST
ACCESS AND VISA CARDS WELCOME
SOUTHERN U.K. AK3 SUPPLIER
PO Box 88, WEYBRIDGE, KT13 0RT

LONDON

ALPHA'S CB CENTRES

224 Balaam Street, London E13
Tel: 01-471 5589
Open: Mon-Sat 9am-7pm:
Sunday 10am-2pm
ALSO
EX ZULU/ONE/FOUR,
132 Leytonstone High Road, E15.
Tel: 01-555 8045. Open: Mon-Sat
9am-5.30pm.
T/A Balaam St. Motors

NORTHAMPTON

EARLS BARTON CB SHOP

Shirley Engineers
FULL RANGE CB EQUIPMENT SERVICE AND REPAIRS
Open Monday - Friday 9-6
Saturday 9-5
Sunday 10.30-12.30
38a DODDINGTON ROAD (STD 0604) 81 0000

OXFORDSHIRE

MODULATIONS COMMUNICATIONS
62 Wootton Road, Abingdon, Oxon. OX14 1JD
Tel: 0235 - 21400
Open: 6 days Mon-Sat 9-5.30

Instant credit facilities. Agents for 934 MHz Wholesale, Retail and NEW CEPT CB NOW AVAILABLE

SURREY



GUILDFORD CB

Surrey's biggest stockists of CB equipment and accessories
Low prices, technical know-how. Repairs. 934 and Amateur Cobras and Yaesu wanted.
34 Aldershot Rd., Guildford GU1 4JZ

HENRY'S

934MHz and 27MHz
CB and accessories catalogue S.A.E.
404 Edgware Road, London W2 1ED
01-724-0323
Open 6 days a week

NORFOLK

BA YEOMANS + SON

ESTABLISHED 1965
Lowest prices in UK or refund difference
Mobile Aerials from £2.99
Base Aerials from £9.99
3 amp Power Supply from £9.99
Used CB from £19.99
New CB from £45.00
Scanners from £49.99
CB Aerial Plugs 40p
CB Microphones from £4.50
65 North Walsham Road, Norwich.
Tel: 426294

SHROPSHIRE

LES EVANS ELECTRICAL CB CENTRE

Unit 7, The Brewery, Wem.
Tel: (0939) 32090 (24 hours)
New and Used CB's
Large stocks of Ariels + Accessories
Prompt Repair Service

SURREY



D.X. CENTRE CB & ACCESSORIES

137 Windmill Road, Croydon.
Tel: 01-684 7457
Mon.-Fri. open till 8.00pm
Sat. open till 6.00pm

LANCASHIRE

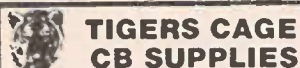

FOR ALL YOUR CB NEEDS MAILORDER WELCOME
Open: Mon-Sat 9am-6pm
Sun 9am-4pm
343, Chorley New Road, Horwich, Lancs. Tel: 0204 68218

NORTH HUMBERSIDE

BREAKER ONE NINE CB CENTRE

414 BEVERLEY ROAD, HULL
Tel (0482) 447560
LARGE SELECTION OF NEW AND SECONDHAND CB EQUIPMENT.
FULL RANGE OF C.E.P.T. RIGS AVAILABLE
EXCELLENT REPAIR SERVICE

SUFFOLK



RADIOCARE
PHONE OR CALL IN FOR BEST PRICES
NORMAL SHOP HOURS (Closed Thurs.)
18 OUT WESTGATE BURY, ST. EDMUNDS
0284 701823

TO ADVERTISE TEL 02-437 0626

ACCESSORIES



WHOLESALE DISTRIBUTORS OF CB

Giant range of CBs and accessories, contact us today for very fast, friendly service, competitive prices, widest range and latest CB products.

Tel: 061-446 8918 061-434 5701
Telex: 666762 PAMACO G
Fax: 061-446 0978
Order Line: 0800 262963

WE DELIVER NATIONWIDE OPEN EVERY DAY, SUNDAY 10-2
Pama House, 433 Wilmslow Road, Manchester M20 9AF Only 3 minutes from M56



BREAKER BASES

SOMERSET

TRAVELLING LIGHT C.B. RADIO SPECIALISTS

Largest stocks in the area.
Repairs/Sales and Service.
2nd Hand Rigs Bought and Sold ...
Also phones, I.C.E. and much more.
Travelling Light, 19 King Street,
Frome, BA11 1BH. Tel: 0373 66281

WEST MIDLANDS

HEWARD'S HOME STORES LTD (Established 1963)

822/4 Kingstanding Road,
Birmingham B44 9RT.
Tel: 021-354 2083
G4RJM with 38 years in The Radio
Trade Ham Equipment urgently
wanted Open: Mon-Sat 9-6
WE WELCOME ALL CB'ers

YORKSHIRE

LEN BERRY ELECTRONICS LTD.

We monitor channel
0723-373914
or eyeball at:
**147 VICTORIA ROAD,
SCARBOROUGH,
YORKSHIRE**

WEST YORKSHIRE

SUPERSLAB CB CENTRE

John A. Dobbins Ltd
Bradford Road, A650,
East Ardsley, Nr. Wakefield
Tel: 0532 524586
**LARGEST STOCKIST OF CB
EQUIPMENT IN THE NORTH**
(Trade and Retail)
Full Repairs Service
Mail Order

SUSSEX

The C.B. Centre

Inrange Ltd, 8 Marine Court,
St. Leonards on Sea.
Tel: Hastings (0424) 443185/442025
Open: Monday to Saturday 9.30-5.30
Retail & Wholesale



YORKSHIRE

EMPRESS TRADING CO. THE No. 1 C.B. SHOP

**WIDE RANGE OF RIGS & TWIGS
ALL ACCESSORIES AVAILABLE,
"PART EXCHANGE WELCOME"**
ALSO, 2 WAY TAXI AND T.V.
AERIALS, TELEPHONES, IN CAR
RADIOS AND ELECTRICAL GOODS.
ANY ENQUIRIES WELCOME.
TEL: (0274) 499340
564 Thornton Road, Bradford BD8 9NF

SOUTH YORKSHIRE

NSC TALKLAND

CREATING COMMUNICATION
Mobile Phones, Cellnet/Voda-
fone - CB - PMR - Cordless
Phones - In-Car Telephones
17 East Laith Gate, Doncaster.
Telephone: (0302) 342277
Portable: (0836) 660606

N. IRELAND

NORTHCOTT ELECTRONICS

**Northern Ireland's Largest
Citizens' Band Radio
Specialist**
Radios, Scanners and
Phones.
Unit 21, In-Shops,
Northcott Shopping Centre,
Glengormley.
Tel: Belfast (0232) 342552
Open: Mon., Tues., Sat.
9.30am-5.30pm
Wed., Thurs., Fri. 9.30am-9pm.

**IF YOU WOULD LIKE TO PLACE AN ADVERTISEMENT IN
CB MAGAZINE EITHER FILL IN THE COUPON BELOW OR
CALL RACHAEL PHILLIPS ON 01-437-0626**

CLASSIFIED COUPON

CITIZENS' BAND, CLASSIFIED ADVERTISEMENT
DEPARTMENT, No. 1 GOLDEN SQUARE, LONDON W1R 3AB.

Private and Trade rate 58p per word (VAT inclusive) minimum 15 words.
Display box rate £9.15 (+ VAT) per single column centimetre (minimum 2.5cm).
NO CLASSIFIED REIMBURSEMENTS. ALL ADS MUST BE PRE-PAID.

PLEASE DEBIT MY ACCESS/BARCLAYCARD No. _____

EXPIRY DATE



Name _____

Address _____

Daytime Tel. No. _____

Signature _____ Date _____

FOR SALE QSLs WANTED KITS ACCESSORIES OTHERWISE STATE

IF YOU DO NOT WISH TO CUT UP YOUR MAGAZINE PLEASE PHOTOCOPY THIS COUPON

ACCESSORIES



WHOLESALE DISTRIBUTORS OF CB

Giant range of CBs and accessories, contact us today for very fast, friendly service, competitive prices, widest range and latest CB products.

Tel: 061-445 8918 061-434 5701
Telex: 666762 PAMACO G
Fax: 061-445 0978
Order Line: 0800 262963

WE DELIVER NATIONWIDE OPEN EVERY DAY, SUNDAY 10-2
Pama House, 433 Wilmslow Road, Manchester M20 9AF Only 3 minutes from M56

01
437
0699

CLASSIFIED

Lineage: 58p per word including VAT
Minimum 15 words
Semi Display: £9.15 per single column centimetre
Minimum 2.5 centimetres
CB Classified Department,
Argus Specialist Publications Ltd.,
1 Golden Square, London W1R 3AB

ACCESSORIES

NEW! from FCC SYSTEMS
REPLACEMENT PLL'S FOR UNIDEN & CYBERNET
FCC80U TO REPLACE TC9119 TC9106 TC9109
UNIDEN 100 - 400 AND AUDIOLINE RIGS
PRICE INC. VAT, P/P £13.85
FCC80C TO REPLACE LC7137 - LC7136
CYBERNET, MIDLAND, HARRIER, AMSTRAD ETC.
PRICE INC. VAT, P/P £12.85
Quantity discounts available. Make cheques, P/O payable to:
FCC SYSTEMS, 71 STATION ROAD, SEAHAM,
Co DURHAM, SR7 0AQ. TEL: 0642 603875

★ STOP PRESS ★ STOP PRESS ★ STOP PRESS ★
"THE SHACK"
New appointed Piranha Car Burglar Alarm Distributor.
★ Special - Trunkers 4½" screen TV's & Omni Directional Vehicle TV Aerials ★
Specialist components, IC's transistors, Cybernet & Uniden spares, car radios, speakers, intercoms, new CB radios from £46. Accessories all at discount prices. All repairs tested on Marconi 2855 test set by Derby's leading rig doctor.
Ring Paul (0332) 760353 (anytime)
THE SHACK, 231 Caxton Street, Sunnyhill, Derby OE3 7RB.

**TO ADVERTISE
HERE
TELEPHONE
01-437-0626**

FOR SALE

934MHz DELTA '1' Pre/Amp, Antenna switch, co/linear, three Yagi beams, 90' H100 cable & connections, £300 o.n.o. or exchange for Ham Jumbo, Hercules, etc. Phone Godalming 29419.

GRUNDIG CB6 Professional Test Unit. Cost over £1700 new. Excellent condition, sensible offers only please. Tel: 01-599 7549.

SPECIALIST SERVICES AND OPPORTUNITIES



**Richard Pitman
FORM GUIDE**

Available each morning from around 0930 hrs, the service identifies the best betting opportunities of the day with full supporting background information from authoritative sources

(0898) 700253
A Portman Publication Service
Calls charged at 25p per minute off peak, 38p peak time

NATIONAL ORGANISATIONS

A.B.C.B.
(Association for British Citizens' Band)
**The National Organisation
Representing
Licensed Breakers
and Clubs**
Large SAE for details to:
ABCB, PO Box 13, North PDO,
Nottingham NG5 2DU

QSLs

GLOSSY QSL and Eyeball cards. Many colours with gold/silver/coloured lettering. S.A.E. order form and samples. Sharp Graphics, P.O. Box 3, Grangemouth FK3 9BD. (0324) 473432.

- Full Colour QSLs 1000 £68
- Personalised QSLs 1000 £17.60
- Eyeball Cards 1000 £10
- Embroidered Patches 100 £120 (sample £2) ● Club Stamps Mounted 50 £50 ● Patches 3" dia. In up to 9 colours. Club stamps 1" dia.
- DIY QSLs 100 £2.60
- Eyeball Cards 100 £1.10
- DIY Bargain Pack 100 of each £3
- SASE for details: CURRIE QSLs Room 2, 89 Derwent Street, Consett, Co. Durham, DH8 8LT, England.

EQUIPMENT

C.B. EXCHANGE
Buy (Working or not) cash by return. Sell fully serviced and aligned S.A.E. for availability or Tel: (0253) 886632 North West House, Poulton-le-Fylde, Blackpool, Lancs. FY6 8BN.

SPECTRUM COMMUNICATIONS
CB radios, accessories, spares and possibly the most professional and experienced service department in the UK. Suppliers of kits and add on modules. Send SAE for kits list to: United 86, Marabout Ind. Estate, Dorchester, Dorset.
Tel: 0305 62250
Open: 9-1, 2-5pm Tues - Fri. 9-1, 2-4pm Sat.

PERSONALISED LEISUREWEAR

T-SHIRTS & SWEATSHIRTS
by
Interprint

MINIMUM ORDER - ONLY 12
FREE DESIGN SERVICE
FREE CARRIAGE
Other Top Quality Personalised Products

Sports Shirts, Ties, Hats, Lighters, Bags, Stickers, Badges, Aprons, Tea Towels
Write for free colour brochure to:
INTERPRINT Dept. CB
CRAVEN ARMS,
SHROPSHIRE SY7 9NY.
FAX 0588 676188

TEL: (0588) 673444

FOR SALE

- MULTI-BAND -
ACTION RECEIVER HI-POWER
ICN-8032s

THE ENTIRE LISTENING POST

- ★ HI/LO/AIR
- ★ VHF 53-180MHz
- ★ CB 27/81 - CEPT - 200 CH's
- ★ SIGNALS OF: TOTAL CB, HAM-RADIO, UTILITIES, AIRCRAFT, EMERGENCY CALLS, WARINE, LOCAL 2-WAY, TAXIS & MORE!
- ★ SQUELCH, RUBBER 'DUCK' ANTENNA, EXTERNAL AUDIO & DC JACKS
- ★ SUPER SENSITIVE + HAND COMPACT

C/W BATTERIES £27.50
& EARPHONE INCL. P/P

FREE CONFIDENTIAL FREQUENCY BULLETIN
24 HOUR C.O.D.
CWO/COD 0388 763323
Direct from: TAYLOR RADIO (Dept. CB3)
8 Emerson Street, Crook, Co. Durham, U.K.

**DO YOU
HAVE ANY
PRODUCTS OR
SERVICES TO
OFFER CB
ENTHUSIASTS?
IF SO ADVERTISE
HERE.**

WHOLESALE

CB radios, aerials and accessories delivered to your shop. Contact for price list.

Pama House, 433 Wilmslow Road, Manchester M20 9AF.
only 3 minutes from M56



OPEN EVERY DAY, SUNDAY 10-2

NATIONWIDE DELIVERY DEALERS

contact us today for very fast, friendly service, competitive prices, widest range and latest CB products.

Tel: 061-446 2437 061-445 8918
061-434 5701
Telex: 666762 PAMAGO G
Fax: 061-445 0978

CRYSTALS

QUARTZ CRYSTALS and FILTERS

Large numbers of standard frequencies in stock for amateur, CB, professional and industrial applications.
Stock crystals £5.50 each (inc. VAT and UK post). Any frequency or type made-to-order from £6.50
Phone or SAE for lists
GOLLEDGE ELECTRONICS
Merriott, Somerset, TA18 5NS. Tel: (0460) 737 18

PLANS

SURVEILLANCE DEVICES, Bug Detectors, Voice, Scrambler, Directional Microphone, Many others. SAE for list, Plans Centre, Unit 7, Old Wharf, Dymack Road, Ledbury HR8 2DS.

SERVICE MANUALS

C.B. CIRCUITS MANUAL

Giant Collection of C.B. Circuits covers over 100 different makes/models.
Only £5.00 POST FREE
Plus FREE catalogue Unique Repair and Data Guides. Most equipment service manuals supplied.
MAURITRON (CB), 8 Cherry Tree Road, Chinnor, Oxon OX9 4QY.

COPY DEADLINE

THE COPY DEADLINE FOR THE JUNE ISSUE IS 6th APRIL 1989



Q. Do you want to market your products or services to 22,000 CB Enthusiasts who spend over £1,000,000 each year on their hobby?

A. Call Rachael Phillips on 01-437-0626 and find out how CB classified can help you do it.

If an advertisement is wrong we're here to put it right.

If you see an advertisement in the press, in print, on posters or in the cinema which you find unacceptable, write to us at the address below.

The Advertising Standards Authority.

ASA Ltd, Dept 3 Brook House, Torrington Place, London WC1E 7HN

C.B. RADIO & MODEL HOBBIES

0279 418817

PARNDON MILL (LANE)
HARLOW, ESSEX.



MAIL ORDERS WELCOME



STOCKS INCLUDE:-

(UK FM RIGS)	(UK CEPT RIGS)
Moonraker Major £85	Alpha 4000 £195
Moonraker Minor £59	Alpha 4002 £175
Jesan KR200 £85	Uniden 450E £115
Maxcom 30E £79	Zodiac 144 £140
Uniden 200 £90	DNT Scanner FM £105
Uniden 100 £79	Uniden 400 £85
Colt 295 £69	DNT Contact 40 £59
Jesan 5005 £79	Hi-Tec (Handset 40) £65
Midland 77104 £65	
Midland 77805 £95	
DNT Transit £65	
Maxcom 7E £75	
Maxcom Talkback	
21E £65	
Harvard 404 £72	
Audioline 342 £69	
Sonic 868 £55	

Cybernet 934 Delta 1 £350
HAND SETS
Jesan/Moonraker/Sonic
£65

TWIGS:-
Sirio 2012 £75
Sirio Tornado £45
CTE Spacelab 5/8 £47
CTE (Sigma 4) 150 £57
Telex Silver Rod £35
GPA 1/2 £12 T-Pole II £20
GPA 5/8 £13 T-Pole III £22
Silver £17

Various used rigs in stock

MICS GALORE (all types)

Mobiles Galore from £17.50

★ REPAIRS ★ ACCESSORIES ★ SPARES ★
TELEPHONES, ANSWERPHONES, IN-CAR STEREO,
RADIO CONTROLLED MODEL AIRPLANES, HELICOPTERS,
CARS, BOATS, HOVERCRAFT, ROCKETRY

WE ARE REPUTEDLY ONE OF THE BEST C.B. & MODEL SHOPS IN THE U.K.

NEVADA

If its advice you need on any aspect of CB radio, then these are the people to talk to.

Your nearest Nevada Main Dealer below has been especially selected for his expertise. Call him now and he will be pleased to advise you. He also stocks the new TRX 404 Transceiver and Selective Calling Unit . . . naturally!

**RETAILERS!
MAIN DEALERSHIP
STILL AVAILABLE IN
SOME AREAS.
CONTACT NEVADA
FOR FURTHER
DETAILS**

**BROOMKNOLL ELECTRONICS
(AIRDRIE)
0236-54580**

**PAMA & CO
(MANCHESTER)
061-445-8918**

**T. HALL
(ASHFORDBY)
0664-812061**

**J FISHLOCK
(BATH)
0225-27718**

**AGRIMOTORS
(MERTON)
08053-200**

**CHATBACK CB
(CAMBORNE)
0209-715773**

**UK DISTRIBUTORS
NEVADA COMMUNICATIONS
PORTSMOUTH
0705-662145**

**AXDON TELEVISION
(PERTH)
0738-23753**

**IAN FISHER
(STANHOPE)
0388-528464**

**KNIGHTS
(KIRTON IN LINDSEY)
0652-648378**

**RILEYS TV
(BOLSOVER)
0246-826578**

**B. A. YEOMAN & SON
(NORWICH)
0603 426294**

**CB EXCHANGE
(BEDFONT)
01-890-0900**

**THE AERIAL SHOP
(SIDCUP)
01-300-5588**

**O.T.S.
(LEIGH-ON-SEA)
0702-714330**

**HENRY'S
(LONDON)
01-724-0323**

**MM ENTERPRISES
(ASHFORD)
0233-620877**

**INRANGE
(HASTINGS)
0424-715709**

Shhhhhhh

Keep this
to yourself!
the **NEW**

**TRX404
TRANSCEIVER**

is going to
upset the
competition

...JUST LOOK AT
IT'S FEATURES



FEATURES

- ★ **A UNIQUE NOISE SQUELCH SYSTEM** Ensuring you hear only FM transmissions through the Squelch and not interference.
- ★ **A SUPERB RECEIVER** Using double crystal filters that drastically reduce co-channel interference (Bleedover).
- ★ **A PROVISION FOR SELECTIVE CALLING** Using our new SR316D Sel Call unit that simply plugs into a socket provided on the TRX404.
- ★ **A SWITCHEABLE 'ROGER' BLEEP**
- ★ **A 4 WATT TRANSMITTER THAT DELIVERS 'PUNCH'.**



MATCHING SELECTIVE CALL UNIT - £59.95

AND ALL FOR JUST

£69.95

AVAILABLE FROM AUTHORISED
DEALERS THROUGHOUT THE UK



THE TRX404 27MHz TRANSCEIVER IS AVAILABLE IN TWO MODELS
 MODEL TRX404UK. ON THE STANDARD UK CHANNELS
 MODEL TRX404 FULLY APPROVED C.E.P.T. RADIO
 MODEL SR316D MATCHING SEL CALL UNIT FOR BOTH MODELS

DISTRIBUTED IN THE UK BY:-

NEVADA

TEAM UP WITH THE BEST

EUROSONIC

communications

*The Sole Importer &
Distributor of these Products*

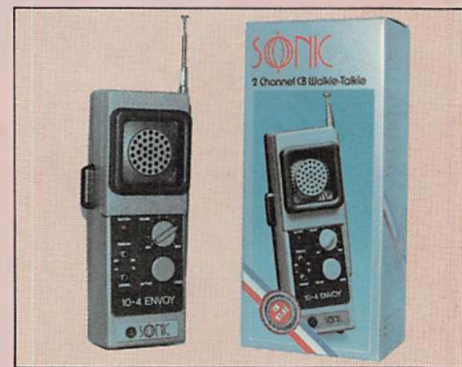

**ALSO STOCKISTS
OF CB ACCESSORIES**

EUROSONIC Communication
Britannia Works Building
Sherborne Street, Manchester M3 1EF
Tel. no : 061 834 8818 Fax no: 061 835 2125