

# CEED

COMPLIANCE



THE MAGAZINE OF BROADBAND TECHNOLOGY / OCTOBER 1989

**Tech training: What are the options?**



**Understanding clamping voltage**

\*\*\*\*\*  
#BXNDZLN\*\*\*\*\*  
#0001 09/20/89 09:01 1 205 JAN  
FRED MC GARRA  
HASTAD FINNENSEN LTD  
HASTAD FIN 05548

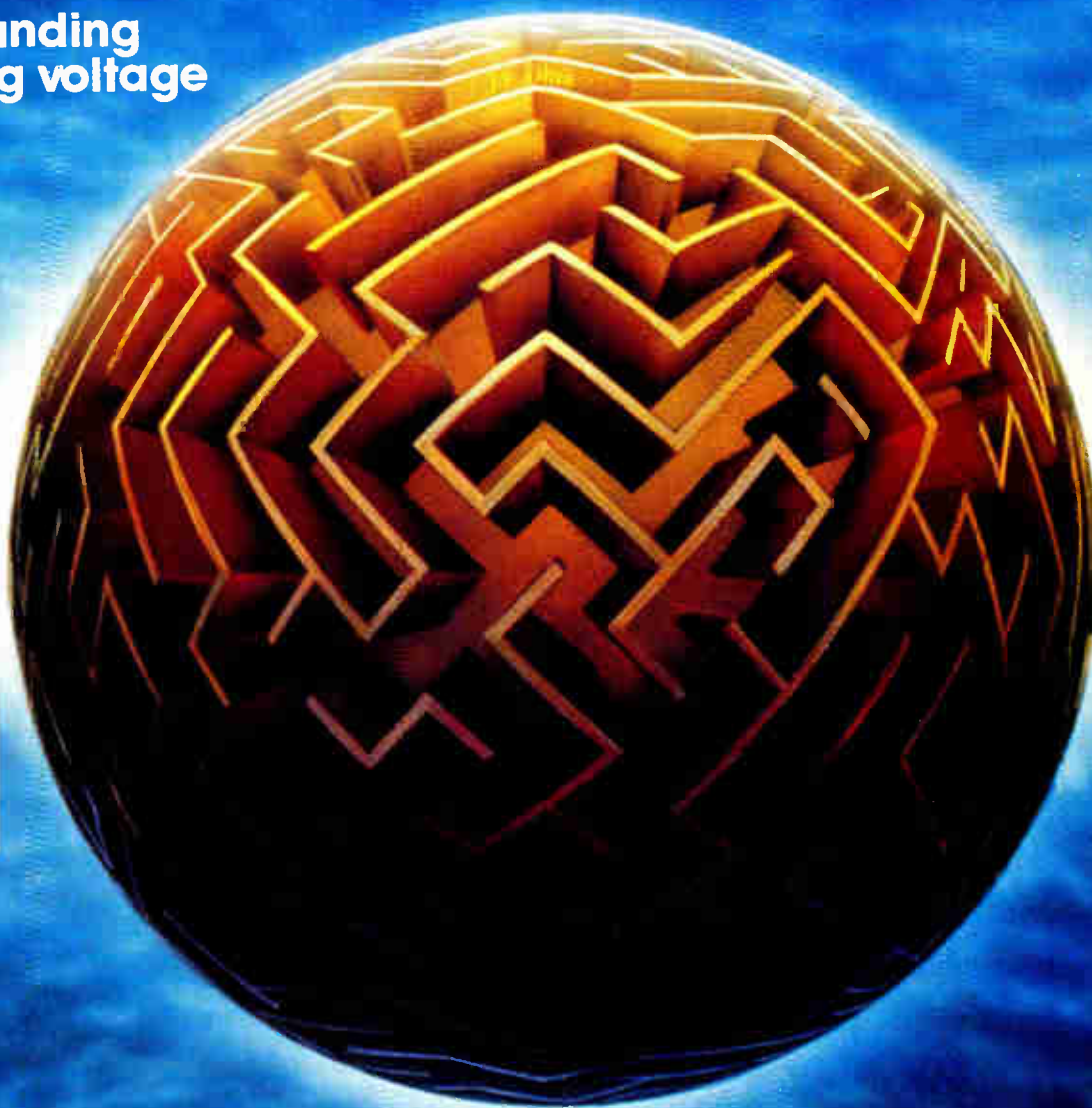

**The world of PPV technology:  
Walking through the maze**



# Panasonic Built. From The Inside Out.

Every time you install a Panasonic® CATV converter, you're assured of uncompromised quality and performance. Because Panasonic CATV converters are designed and manufactured by its parent company, Matsushita Electric. Which means each CATV converter is Panasonic built. From the inside out.

Take the Panasonic TZ-PC140/170 Series. Employing the latest in manufacturing technology, Panasonic converters are built to exceptionally high quality standards. It's the quality your subscribers have grown to expect from Panasonic. And that will help avoid costly service calls.

And to provide today's subscribers with the sophistication they associate with all Panasonic video products, the TZ-PC140/170 Series provides features like BTSC stereo compatibility, skip-scan tuning and remote volume control (170 Series), to name a few.

Panasonic CATV converters. Built for you and your subscribers the way all converters should be. From the inside out.

## Panasonic Video Communications

For more information call:  
Northeast 609-589-3063 Midwest 513-530-9216  
Southeast 404-925-6845 West 415-947-0147

Reader Service Number 1



## NO DROPOUTS

Now that Trilogy has a complete line of foam drop cables, you don't have to go elsewhere to move inside after your MC<sup>2</sup> trunk and feeders are in place.

And you get the savings of one-stop

shopping in all installations.

Take it all the way in with Trilogy and go forward with confidence with the most rigorous quality control found in the industry.



### Trilogy

COMMUNICATIONS INC.

Call or write for our free sample and brochure: TRILOGY COMMUNICATIONS INC., 2910 Highway 80 East, Pearl, Mississippi 39208  
800-874-5649 • 601-932-4461 • 201-462-8700

Reader Service Number 2

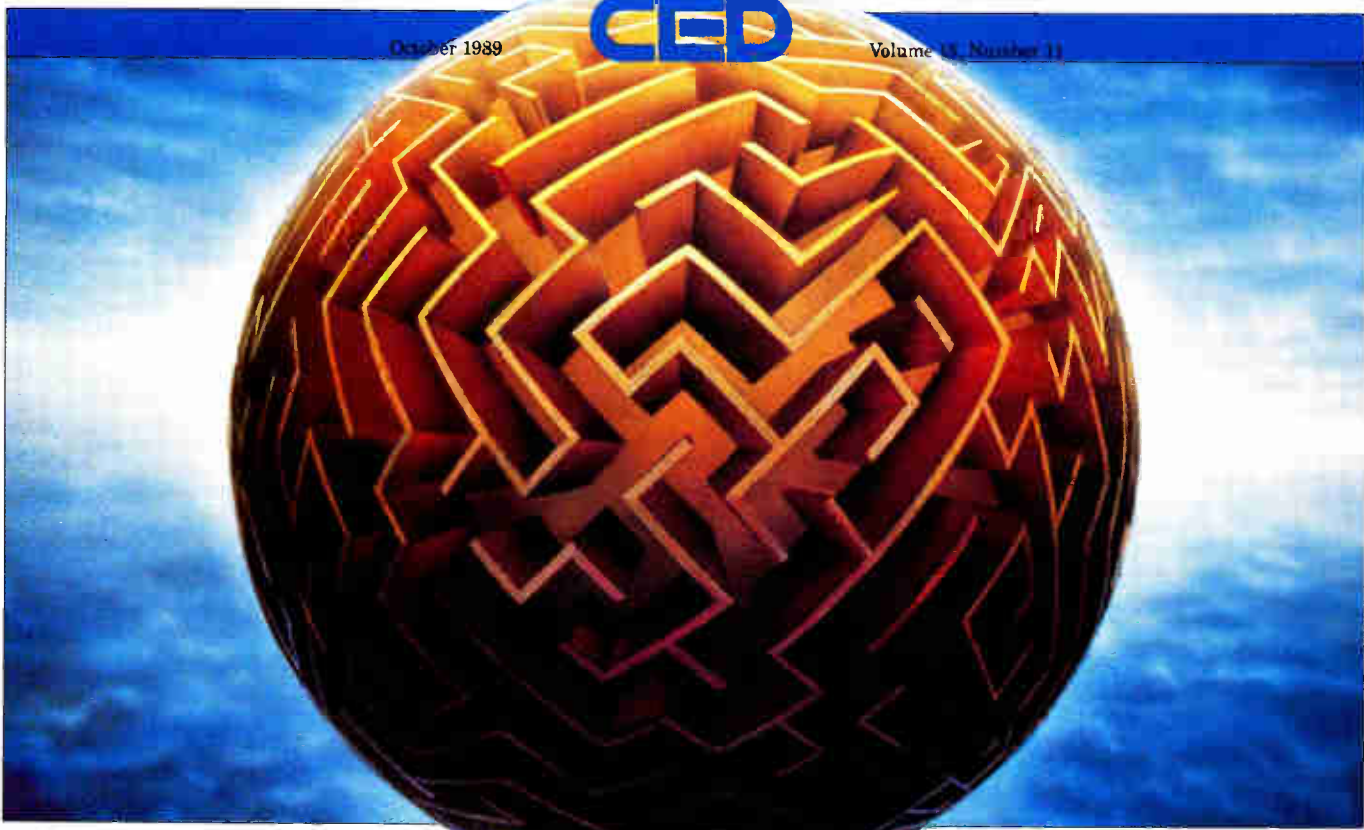

**Choosing the right ordering system**

With promises of pay-per-view increasing bottom line revenues, cable operators are working through a maze of technology options, searching for just the right mix of simplicity, efficiency and cost-effectiveness. The answers are hardly unanimous.

**32**

**About the Cover:**

*As PPV becomes more common, a question to consider is which ordering system to implement. How operators are working their way through the PPV technology maze is the focus of*

*this feature story on page 32. Cover illustration by J.F. Podevin.*

**Training for the future of CATV**

Technicians who consider their jobs as careers have a variety of options when it comes to training programs. This story examines all the options: in-house centralized and decentralized methods, custom programs and associations.

**40**

**CLI COMPLIANCE**



*Want to know where those leaks are? See page 82.*

**DEPARTMENTS**

- In Perspective . . . . .8**
- Color Bursts . . . . .12**
- Spotlight . . . . .16**
- Frontline . . . . .20**
- From the Headend .22**
- Capital Currents . .24**
- NCTA Notes . . . . .26**
- SCTE Focus . . . . .90**
- What's Ahead . . . . .96**
- In the News . . . . .98**
- Classifieds . . . . .102**
- Ad Index . . . . .106**

**Getting short-haul quality over fiber**

Dennis Donnelly with Catel Telecommunications discusses how to meet RS-250-B short-haul transmission requirements.

**48**

**Delivering broadband RF in a hospital environment**

In this in-depth article, John Gutierrez with ComNet Engineering and David Philips with Netserv Inc. look at the cabling mediums used in hospitals to connect voice, data and video communications.

**64**

**Protection from overvoltage**

Ron Chapman with Advanced Protection Technologies studies the role of surge suppressors and their importance.

**78**

**CLI COMPLIANCE**

**Plugging the holes—if you can find them**

With only 10 months to go before July 1, 1990, the issue of CLI is still omnipresent. In this look at signal leakage, Steven Johnson with ATC explores the causes of leakage and what to do once they're found.

**82**

©1989 by International Thomson Communications Inc. All rights reserved.

CED. (USPS 330-510) (ISSN 1044-2871) is published monthly except twice in May by International Thomson Communications Inc. 600 S. Cherry St., Denver, CO 80222. ©October 1989. Volume 15, Number 11. Subscriptions free to qualified industry readers. All other one-year subscriptions are \$36, prepaid in U.S. funds only. Second-class postage paid at Denver, CO, and additional mailing offices. CED is published on behalf of the cable television and broadband communications industries. POSTMASTER: Please send address changes to CED Circulation, 600 S. Cherry St., Suite 400, Denver, CO 80222. MEMBERS OF THE BPA.



# Better VideoCipher® Solutions

NEXUS builds two VideoCipher® solutions to satisfy all your descrambling needs - the Nexus IRD-1 Integrated Receiver Descrambler and the VCMB VideoCipher® Mainframe. Nexus was the first manufacturer in the world with two commercial VC® II products approved by General Instrument.

To maximize the reliability of your headend, Nexus applies three innovative design principles to every product we manufacture. We:

- decrease power consumption, by designing more efficient products,
- lower operating temperature, by locating the power supply outside the unit, and
- design more advanced circuits which require fewer interconnections.

The IRD-1 and VCMB offer exceptional reliability because they consume less power, have fewer interconnections and generate less heat.

**Compare our lower power consumption, reduced heat generation and increased reliability to all other VideoCipher® solutions.**

TEL:(206)644-2371 BELLEVUE, WA. or (604)420-5322 BURNABY, BC. FAX:(604)420-5941  
WRITE:NEXUS ENGINEERING CORP., 7000 LOUGHEED HWY., BURNABY, BC. V5A 4K4

The VCMB's unique vertical orientation significantly increases airflow and further improves reliability.

Both products are incredibly easy to maintain. Unique front-loading of the VideoCipher® II modules greatly reduces service time. And both units offer significant space savings over stand-alone VC® IIs.



*The Nexus IRD-1 packages a commercial satellite receiver and a VC® II module in 2 and 5/8 inches of rack space.*



*The Nexus VCMB packages six VC® II modules in less than 13 inches of rack space.*

All Nexus headend products are covered by our **FAMOUS FIVE-YEAR WARRANTY.\*** VideoCipher® II modules are covered by General Instrument's warranty.



\*Contact us for details.

**NEXUS**  
ENGINEERING CORP.  
PERFORMANCE  
YOU CAN SEE  
*rely on*

# Take the heat off new Heat Dissipat

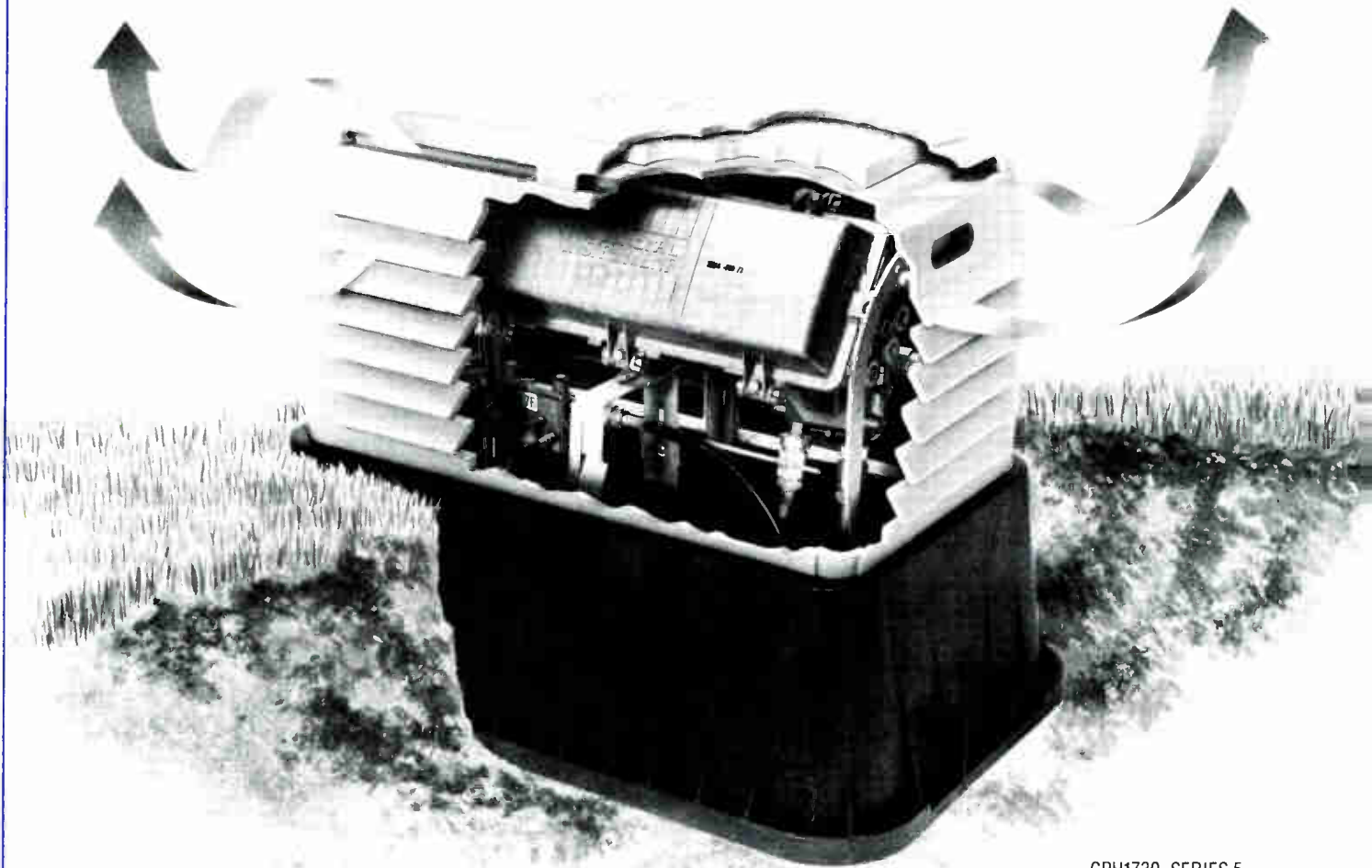

CPH1730-SERIES 5

**MARKETED EXCLUSIVELY BY**

 **Integral  
Corporation**

Channell Commercial Corporation

**800/423-1863**

**800/345-3624  
in CA**

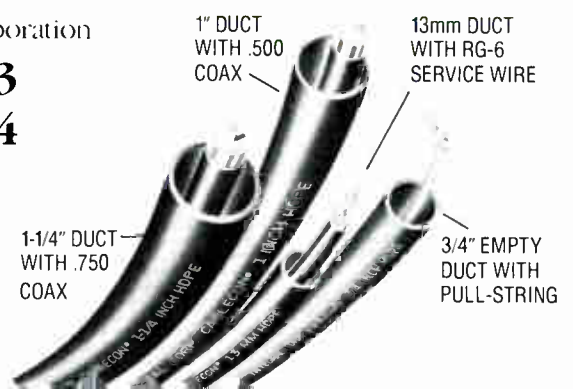

# with Channell's ion Covers (HDC™)!

## Channell and Integral... Setting the standards for underground plant.

Have you considered what heat can do to your line extenders and trunk amplifiers after you splice them into pedestals? Excessive heat on CATV active devices is known to cause component reliability problems. It can keep your technicians busy in summer months responding to signal outages or necessary amplifier adjustments. That's why Channell has developed the **new** "Series 5" Heat Dissipation Covers (HDC).

These single insulated, dual cavity covers are 75% more efficient than metal in dramatically reducing temperature extremes

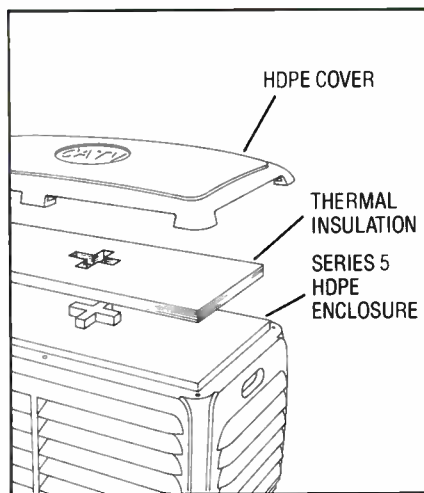

in your amplifiers, especially on the IC boards and power supplies. Independent field testing of "HDC" covers against competitive metal enclosures indicates this percentage could be even higher,

depending upon the size of metal enclosure used in relationship to the amount of active and passive equipment spliced in it.

To prolong the life of your active equipment and increase system reliability, contact Channell today. Let us show you how our "HDC" covers can take the heat off your active devices, and assist you in preventing premature underground amplifier component degradation.

Put our high standards to work for you in your underground plant. Ask for information on Channell's complete family of above and below grade pedestals and enclosures, and Integral's full line of fiber and coax Cablecon® products.

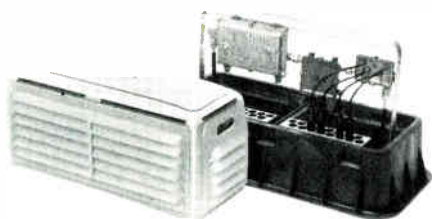

CPH1230-SERIES 5



DCPH2436-SERIES 5

 **Channell  
COMMERCIAL  
CORPORATION**

800/423-1863

800/345-3624 in CA

Reader Service Number 4

See us at the Atlantic Cable Show, Booth #600-602.

## The need for standards and practices

Sometimes, you have to wonder how the cable TV industry ever survived, much less thrived. But, like cities without zoning restrictions, the industry continues to grow with nonstop speed and often without any vision for how all the parts should fit together.

What I'm talking about is standards—or rather, the lack of them. Excepting the NCTA system performance guidelines and a few federal regulations, CATV is essentially devoid of any technical standards. How then, have scores of different manufacturers managed to produce literally hundreds of thousands of parts and make them all fit together without guidance?

In fact, it doesn't always go smoothly. F-connectors aren't always the same length, crimp sizes are a mystery, port sizes don't match, etc. It's as if no one's calling the shots.

But, quietly, that's all beginning to change. Under the auspices of the SCTE, an Interface Practices Committee has been examining this lack of direction and is planning to adopt standards, or at the very least, minimum practices that both manufacturers and operators can agree on. The result should save everybody some money while improving reliability and picture quality.

Taking the lead from the Electronic Industries Association, which has been setting standards for decades, this committee is trying to get operators and vendors to agree on some minimum practices to make the entire cable system work better. The goal: to publish a set of practices, guidelines and procedures that would, for the first time, provide universal F-connectors; recommend that drop cable have bonded foil tape and at least 60 percent braid; consistent core depths; standardized test procedures and printed hex crimp sizes, among other things.

The committee is chaired by TCI's Tom Elliot and subcommittees are focusing on drops, the trunk and feeder, and testing. So far, the response has been encouraging. "People are beginning to see the light," says Barry Smith of TCI, who chairs the testing subcommittee.

We applaud the work of this committee, and the efforts of people like Jones Intercable's Ron Hranac, who spearheaded a drive to establish 75-ohm traceability. All these efforts point to the fact that the industry finally realizes it needs to move forward in the most efficient way possible. There should be more effort placed on practices that save everyone money.

Roger Brown  
Editor

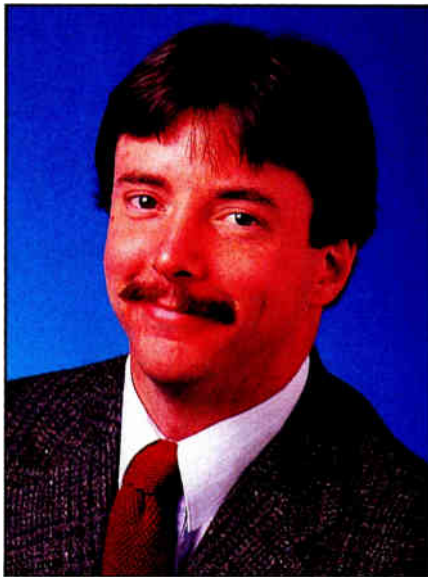

**William McGorry**, Group Publisher  
**Robert C. Stuehrk**, Associate Publisher

**EDITORIAL**

**Roger Brown**  
Editor

**Kathy Berlin**  
Managing Editor

**George Sell**  
Contributing Editor

**CONSULTING ENGINEERS**

Chairman

**Wendell H. Bailey**, NCTA VP, Science and Technology

Members

**Jim Chiddix**, Senior VP, Engineering and Technology, ATC

**John Dawson**, Engineering Consultant

**Roy Ehman**, Director of Engineering, Jones Intercable

**Tom Elliot**, Director of Research and Development, Tele-Communications Inc.

**Jim Farmer**, Principal Engineer, Scientific-Atlanta

**Paul Heimbach**, VP Engineering, Home Box Office

**Fred Kaiser**, President, Alpha Technologies

**Dave Large**, Director, Video Product Planning, Raynet Inc.

**Robert Luff**, VP Technology, Jones Intercable

**Steve Raimondi**, VP Engineering, UA Cablesystems Corp.

**Joe Van Loan**, Engineering Consultant

**PRODUCTION**

**Jeff Knight**, Production Director

**Don Ruth**, Art Director

**Elaine Callahan**, Production Manager

**Dick Benson**, Circulation Director

**ADVERTISING**

**Cathy Wilson**, National Sales Manager

**Judy Medley**, Account Executive

**Curt Stocker**, Classified Sales Manager

**MARKETING AND SUPPORT**

**Michelle Pazar**, Author Support and Quality Assurance

**Linda Hendrick**, SCTE Chapter Support

**OFFICE**

Denver 600 S. Cherry Street, Suite 400, Denver, CO 80222 (303) 393-7449. Fax (303) 393-6654.

**ITCI**

INTERNATIONAL THOMSON  
COMMUNICATIONS INC.



# How Most People Reacted When Told We Could Improve Their Image.



Introducing the new CAT100R, a startling new development from Uniden Satellite Television. The CAT100R features direct entry in 1 MHz steps, so you get pinpoint tuning. Pictures come through with incredible clarity, and the sound, in unbelievably rich stereo. The CAT100R can also operate on both C and Ku bands. It's MAC-compatible. And since it's from Uniden, you're assured of the highest quality and best features at an astonishing price. So if you're the least bit image-conscious, the only choice is Uniden's CAT100R. *Putting you face to face with a world of entertainment.*



For more information write: 4700 Amon Carter Blvd., Ft. Worth, TX 76155 or call (817) 858-3468

**uniden**<sup>®</sup>  
Commercial Satellite Television

Reader Service Number 5

## COLOR BURSTS

### TCI, Jerrold offer addressable module

It took a half-dozen years, but Tele-communications Inc. believes it has finally solved the interface problem between addressable set-top converters and consumer electronics gear.

TCI and Jerrold recently unveiled an addressable module that fits in TCI's "on-premise" box, clearing the way for transparent delivery of broadband video signals into the home. The 8-port module, dubbed "Starport" by Jerrold, offers four addressable ports and a disconnect feature. Jerrold officials said this version of Starport is the first of what is anticipated to be a family of products.

Starport is placed inside TCI's tamper-evident, all-weather plastic box, which is attached to the outside of a subscriber's home. Conventional traps are used to deliver or deny pay services (see photo). TCI will begin to phase in the technology in its Boulder, Colo. system.

The on-premise program is the brainchild of Tom Elliot, TCI's director of research and development. The concept is designed to deliver video signals in a customer-friendly

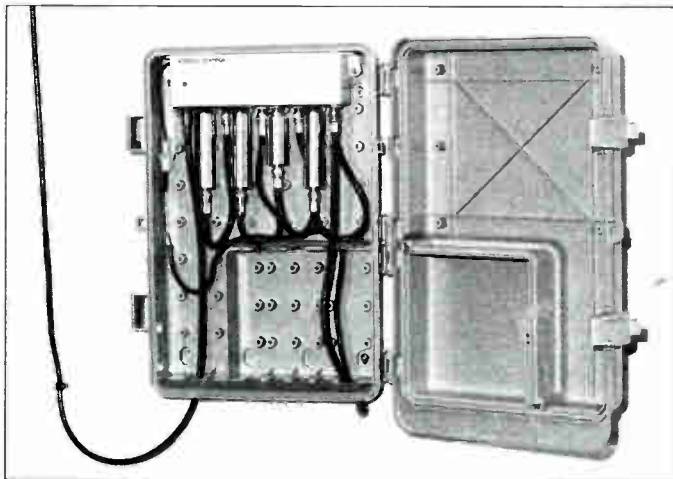

*TCI's on-premise unit utilizes traditional trap technology and now features an addressable module.*

manner, increase system reliability through reduced splicing and drop work and reduce costs through fewer truck rolls and the elimination of equipment theft. In addition, TCI systems can alter subscribers' service without ever having to enter the home, solving the missed appointment problem.

TCI presently has about 500,000 non-addressable on-premise units installed throughout the country. The Starport addressable module will be installed in TCI systems during the normal course of rebuilds and system enhancements over the next few years.

In a deal valued at about \$16 million, TCI placed an initial order for 250,000 Starports and will begin to take delivery from Jerrold in February 1990, according to Jerrold executives. The module, which is priced at about \$70 each, is being manufactured in Jerrold's Taiwan facility.

The module is entirely compatible with Jerrold's existing addressable data stream, according to Elliot. "This just lays in on top—we don't need any new software," Elliot added.

With the addition of addressability to its systems, TCI,

# WORKING



## Some suppliers could care Next time, try MIDWEST.

Need construction material? Now? No problem. We've got it.  
Pedestals. Hard hats. Screw anchors. Tool bags. Connectors.  
Sizing tools. Strand lashers. Coring tools. Gloves. Ground rods.  
Heat shrink. Safety cones. Lashing wire. Nuts. Bolts. And more!

Corporate Office  
Charleston, WV  
304 343-8874

Central Region  
Lafayette, IN 800 382-7526  
Outside IN 800 428-7596

Clarksburg  
Outside



# less about your construction material needs. CATV. The supplier who gives a dam.

All from quality manufacturers and ready to ship nationwide.  
For quick service, call any of our offices today. Just tell 'em the Beav sent you.



A division of Midwest Corporation  
*More than supplies. Solutions.*  
Reader Service Number 6

**Eastern Region**  
WV 304 624-5459  
WV 800 532-2288

**Northeastern Region**  
Pottstown, PA 215 970-0200  
Outside PA 800 458-4524

**Southern Region**  
Ocala, FL 800 433-4720  
Outside FL 800 433-3765

**Southwestern Region**  
Dallas, TX 214 271-8811  
Outside TX 800 421-4334

**Western Region**  
Denver, CO 800 232-9378  
Phoenix, AZ 800 782-4566



which has long resisted entrance into traditional pay-per-view, now believes it is poised to offer pay-per-event services to its subscribers. "We feel that pay-per-event has a better chance for success with this technology in place," said J.C. Sparkman, executive vice president and chief operating officer of TCI.

A demonstration set up in Jerrold's Hatboro, Pa. headquarters linked the manufacturer with TCI's national addressable center in Denver via satellite and emulated what a subscriber would go through to order special event programming. A working model of the on-premise system authorized the event just four seconds after contact was made by telephone. "That's what I call real-time, customer control of an event," said Sparkman. "This is the way we've wanted to do this for a long time."

The module has been under development for more than two years, said Tom Martin, director of research and development at Tocom and the one charged with making the product small enough to fit in the outdoor box. In order to meet strict size requirements, a significant amount of surface-mount technology had to be incorporated. The result, however, is a highly reliable device that requires little power and therefore generates little heat, said Martin.

In an unrelated development, TCI also announced its intent to utilize a full line of Jerrold equipment, including the new SX amplifier, during its system rebuilds. The SX line is backward-compatible with Jerrold's previous equipment and serves as a "platform" to accommodate future technolo-

gies, such as fiber optics and expanded bandwidth for advanced television.

## Cable, telephone coexist at resort

An interactive cable television and telephone service was recently launched September 13, 1989 in Keystone, Colo. by TwixTel Technologies Inc. and Heritage Cablevision. The TwixTel system is designed for short-term renters (or time-sharing occupants) in condominium and resort areas to have access to "pay-per-stay" premium cable services, pay-per-view (PPV) movies and events, hotel-type amenities and direct-billed long distance telephone services.

The TwixTel technology permits access to and controls telephone and cable services using existing cable technology with custom applications software and includes: a converter, activated from a cable controller at Heritage's headend; a telephone access controller with propriety software connected to the telephone of the resort unit; a regional transaction center, which includes a tandem telephone switching system and various peripherals integrated through custom applications software; and a centralized computer network management center with customer service representatives to provide support.

Using a touch-tone phone, the guest is automatically connected by the access controller to the regional transaction center. The guest is then voice prompted to enter a credit card number

and select the desired services. Initial sign-on institutes a credit-card verification and charge authorization through a real-time data link to the network management center. Subsequent TwixTel service is billed directly to the credit card.

Kevin Rice, senior vice president of operations for Heritage Cablevision in Des Moines, Iowa, sees the service as having three major benefits to the CATV industry. One is a desire to enhance the level of local service in resort areas; secondly, to prevent competition in resort areas offered by non-franchised cable operators; and lastly, to gain the potential revenue stream possible by the venture. "The key to the success of the service," says Rice, "is how rapidly resort owners respond to TwixTel."

## Jones gives final OK to Catel for TransHub III

After months of internal delay, Jones Intercable has given Catel Telecommunications full approval to the manufacturer's TransHub III, which will be used in Jones' 800-mile fiber rebuild of the Broward County, Fla. rebuild.

The TransHub units, which convert AM signals from optical sources into VSB/AM for coaxial delivery, were certified to conform with all Jones' specs. Jones will eventually take delivery of more than 30 TransHub units and more than 50 transmitting lasers for its Broward system.

In other fiber optic news, Cablevision

Industries announced it utilized Scientific-Atlanta's AM fiber system for a 14-mile AM interconnect in its Los Angeles system. The interconnect serves 75,000 subscribers in the West San Fernando Valley.

The fiber plant, which crossed three freeways, was completed in just seven weeks. Eight single mode Corning fibers in a Sicoor jacket make up the interconnect. ■

—Roger Brown and Kathy Berlin

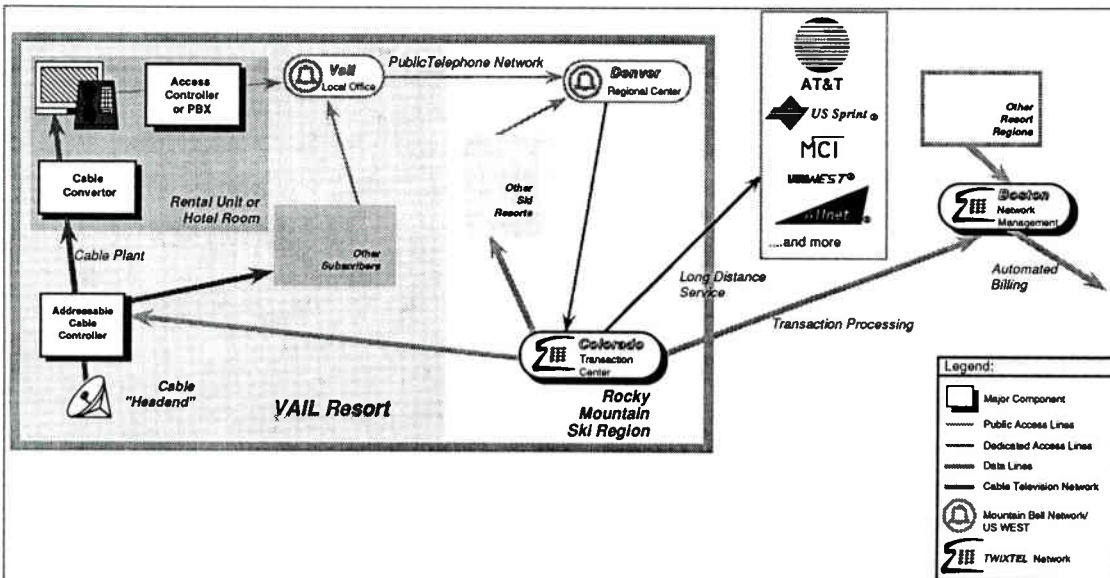

TwixTel's network model for the Rocky Mountain ski region.

# How Do You Fit 10<sup>1</sup>/<sub>2</sub>" Of Equipment Into 3<sup>1</sup>/<sub>2</sub>" Of Space?



You use the industry's first integrated receiver/descrambler—the 9650 IRD! With headend space at a premium, the 9650 IRD is the best way to beat today's rack space squeeze.

Combine the industry leading 9640 receiver with a VideoCipher® II descrambler in one unit and you have it! Seven inches of extra rack space, assured compatibility, and reduced cabling.

Order the 9650 IRD without the descrambling module now and you can

## The 9650 IRD.

add descrambling capability when you need it.

You'll fit twice the channels in the same rack space with perfect compatibility. Add up the difference. The 9650 IRD — we do it right. Call or write Scientific Atlanta Dept. AR P.O. Box 105027 Atlanta, GA 30348 1-800-722-2009.

### Scientific Atlanta

Our customers are the winners.



Tom Jokerst

## Staying afloat with cable TV

Although it's probably not the best learning environment, being thrown into a lake is a well-known method to teach someone how to swim. Yet, this type of "force-fed" education is how Tom Jokerst, assistant vice president and director of engineering for the Illinois-Iowa-Missouri region of Continental Cablevision, received his initial CATV technical training.

Jokerst's cable career started inauspiciously enough. After completing a technical education at Ranken Technical Institute in St. Louis and Southern Illinois University in Carbondale, Ill., Jokerst was offered two positions.

Having to decide between GTE as a transmission engineer or cable television, Jokerst "considered them both and chose the cable route," he says. So, in 1971, Jokerst worked as a video engineer with Cable Information Systems, who was building new cable systems in Carbondale and Marion, Ill. The Carbondale system was also doing a lot of local origination. Unfortunately, the LO strategy was "ahead of its time," says Jokerst. "We were certainly ahead of technology in that we were trying to do local news, local events and even local commercials using portable video equipment."

### Poor picture quality

Because of time base instability

problems with the half-inch VCRs, picture stability was poor, viewer acceptance low and the local origination programs dwindled. "It was good though," reflects Jokerst. "I got one heck of an education on video. The entire experience was a baptism by fire." During this time Jokerst, who was the only person on staff with a technical background, found himself being pulled into day-to-day operations of the outside plant and headend as technicians struggled to solve problems.

Shortly after Jokerst became familiar with the outside plant and headend, the system chief technician was dismissed and Jokerst was put in charge. Thus began Jokerst's force-fed education. "You learned to be expedient and not necessarily analyze things but get them done," says Jokerst.

After a couple of years, Jokerst was approached to manage a newbuild in Rockland County, N.Y., and decided to take the job. "You're not always so smart when you're young," says Jokerst. "I didn't really talk a lot about compensation. I assumed the salary they would offer me would be commensurate with the cost of living increases."

### The good years

Only after Jokerst hired his replacement for the Carbondale system did he realize he couldn't maintain an equal standard of living in the New York area. Luckily, Cable Information Systems had an opening in Winchester, Ky., and in 1974, Jokerst headed for the 60-mile system. "Those were the happiest years of my cable life," muses Jokerst. He still found his way to New York by temporary assignments of two to four week stints to help out during the construction and system turn-on. Because the manager (and former system owner) was out pursuing other interests, he left Jokerst to run the Winchester system. "Not that it needed a lot of attention from a management standpoint," says Jokerst, "but the outside plant was a different story.

"It had lots of problems," he continues. "I found things I could do that didn't cost a lot of money. The first thing I did was improve the off-air reception on some channels that had been bad since day one." Two years later, Jokerst felt he had "done what I could for the system" and decided to leave.

"I don't know what possessed me to leave," says Jokerst. "It was a great situation, wonderful co-workers, I had a lot of fun things to do—maybe it was the lack of a challenge," he adds. Regardless, the system in Carbondale had the chief technician position open again and Jokerst transferred back.

After returning to Carbondale, Jokerst not only continued to troubleshoot the system but also started attending the National Cable Television Association's (NCTA) annual conventions, (at his own expense). "It was some of the best money I've ever spent," says Jokerst.

Since the mid '70s didn't boast as many trade publications as are now available, both the NCTA conventions and SCTE provided a good source of technical information. Through the meetings, Jokerst was able to get together with others in the industry and discuss problems and solutions. It was these meetings that enabled Jokerst to establish several vendor relations which Jokerst ultimately credits as influencing his move to Quincy Cablevision, an affiliate of Continental Cablevision.

Jim Wand, vice president of Continental's Iowa/Illinois/Missouri region, was looking for a director of engineering and by talking with various people in the industry, "my name was passed on, along with others I'm sure," says Jokerst. In 1976, Jokerst accepted the position of director of engineering for Continental based in Quincy, Ill. "It was a great move," he states.

### Moving up

Continental kept growing, upgrading, and improving systems and in 1979, Jokerst was promoted to assistant vice president and director of engineering. It was also at this time that Continental decided to "be where the action was" in terms of franchising and relocated the original Quincy office to St. Louis. To Jokerst, his role now is "to establish direction and keep informed of the issues so we (Continental) know how to plan long term.

"I also need to keep people up to speed on technology," says Jokerst. "I try to set high standards and then fill it. It's one thing to say these are our goals and another to accomplish them." Two of Continental's technical corporate goals stand out in Jokerst's mind. One was to have all systems capable of a minimum of 35 channels by 1986,

# the **SOURCE**

**Take your signal from Sony.**



For CATV, SMATV, broadcast or business television, the FSR-1100 is the most reliable, flexible high performance commercial satellite receiver available for the money.

Whether you're operating on the Ku or C band, Sony's FSR-1100 receiver provides the superior video and audio reception viewers expect. The FSR-1100's unique adjustable detector bandwidth allows quality reception even under adverse signal conditions. And its advanced operating features make it easy to use.

When you choose the FSR-1100 you're choosing Sony quality. Sony's unsurpassed experience and commitment to excellence in professional broadcast and industrial video equipment coupled with Midwest's outstanding support and service make a winning combination that can't be beat. Get the picture? You will if you take your signal from Sony.

For more information about the Sony FSR-1100, call one of our sales representatives today.

**SONY**® is a trademark of Sony.

  
**MIDWEST**  
Communications Corp.

One Sperti Drive  
Edgewood, KY 41017  
**1-800-543-1584**  
In Kentucky, 606-331-8990

# CLImax Standards from the FCC

## Comply or Suffer the Consequences

Maximum time: July 1, 1990

Maximum fine: \$20,000 per leak

Maximum service penalties: loss of  
channels



## Simple Solution

The cable you use has a great impact on the leakage problem. Using an inferior cable will only compound your problems. One way to keep your system up to standards is by using TIMES FIBER cable.

TIMES FIBER manufactures their cable to help you now and in the future. Less maintenance and lower equipment cost mean money in the bank when you install TIMES FIBER. Rebuilds and expansion

become a cinch. With the reliability of this cable do you really want to risk your system by using cable from someone else?



Power & Tel stocks a full line of TIMES FIBER. Whether it's trunk or drop we have it ready to ship. In a world where service is Number One we're geared to give it to you better than the rest.

Buying from Power & Tel won't send you to the poor house either. You may spend less elsewhere but will you get the TIMES FIBER quality and the Power & Tel satisfying service?

Reader Service Number 9

**Power & Telephone Supply Company**  
**1-800-238-7514**

Call us now for more information on TIMES FIBER cable and for the location of the branch nearest you.

## SPOTLIGHT

which was achieved. A second goal was to meet the FCC requirements on CLI compliance a year early. "I did it in my group and overall in the company I think we did it," says Jokerst. "One of our systems had no leaks at all above 10  $\mu$ V/m."

For both keeping up on technology and staying informed of issues, Jokerst relies on a lot of reading and his heavy involvement in the industry. Currently, Jokerst is a member of the Institute of Electrical and Electronic Engineers (IEEE), the NCTA Engineering Committee, a senior member and past regional director of the Society of Cable Television Engineers (SCTE), the Society of Broadcast Engineers (SBE) and a member of the CableLabs Technical Advisory Steering Committee. Jokerst is also chairman of the CableLabs Consumer Electronics Interface Subcommittee and a member of the Fiber Optics Subcommittee.

"I think it's a real privilege to be the company's representative for the NCTA Engineering Committee and Cable Labs," says Jokerst. As for what Jokerst contributes to any of the committees, he sees it as "not as much as what I contribute as to what I get out of it. Hopefully, I can pass useful information along to others in the company."

## Optimistic outlook

"From the standpoint of being on the fiber optics subcommittee, it is an issue that is of strategic importance," Jokerst continues. "The one thing I can say is prior to seeing more of fiber and the emergence of CableLabs, I was concerned about the role of the cable industry. If there was going to be a role," he states. "Now I would say I've never been more positive about the industry than in the last year or two—simply because fiber opportunities are presenting solutions to problems like long cascades and reliability."

For those who want to play a part in that future role, Jokerst suggests "reading and studying everything you can get your hands on. Put yourself as much as possible in the eyes of the customer," says Jokerst. "It's also important for people to have experience in more than one system," he adds. "I view that as an advantage because you develop, you see a lot of different ways to do things. You have choices." Perhaps it's one way to learn how to swim, instead of floundering, or sinking. ■

—Kathy Berlin



The problem with separate receivers and descramblers is that by the time you have one of each, you don't have enough rack space left to mount a sheet of paper.

Enter the Agile 40C/K-IRD Integrated Receiver/Descrambler.

A single unit contains both the Standard Agile 40C/K and a VideoCipher® commercial descrambler. So you save about eight inches of rack space for every one you buy.

But don't let the small size fool you. The 40C/K-IRD is built to give you top perfor-

mance 24 hours a day. The unmodified receiver and a more efficient descrambler are completely RF isolated and have separate power supplies and heat sinks to decrease internal heat and greatly increase reliability.

It's also easy to set up and maintain. The proven Agile 40 C/K receiver has all the features cable operators need most: rock solid 100 KHz PLL tuning, 70 MHz IF with a front-panel test point to help minimize terrestrial interference, and Standard's internal 950-1450 MHz active loop-thru design to eliminate signal splitters. In addition,

the IRD front panel keeps the familiar commercial VideoCipher Power, Sync, Authorize and Bypass status lights.

Your local Standard representative has the full story.

But you might start thinking now about what you'll do with all that available space.

 **Standard**  
Communications  
SATCOM Division

P.O. Box 92151  
Los Angeles, CA 90009-2151  
Telephone: (800) 243-1357  
In California: (800) 824-7766  
(213) 532-5300 • Telex: 67-7173

Represented in Canada by:  
DGH Communication Systems Ltd.  
Scarborough, Ontario • 416/499-4746

Specifications subject to change without notice.





## Growth through education

If there's one circumstance all of the talk about advanced television has created, it's an enormous amount of interest in Congress on the general issue of American competitiveness. That interest doesn't limit itself to only consumer electronics, micro-chips and other such things; this lack of competitiveness is discussed at great length as to the range of possible causes and results. Because of this interest, papers and studies have been produced. Being privy to several of these, I have made some interesting observations about what the leaders in and around Washington think are some of the problems.

An alarming number of these papers and studies seem to indicate that our competitiveness is dying because Americans aren't able to invent new technology. The theory goes that whoever invents a technology controls the licensing and manufacturing of that technology. This in turn creates jobs and wealth in the inventing nation. I think it goes without saying that Americans do less inventing and patenting than we should. But, the real question is, why is that so?

No one can legislate invention. Invention must come from creativity which is fueled by education, resources and corporate and government commitment. There are plenty of examples of

things that have been "invented" in this country and which should have produced vigorous industries on American soil. However, for one reason or another, it has not been done.

Regardless of how this came about, it shows that it's quite possible to be the patent holder and inventor of a technology and yet not make any great strides in the control, manufacture or marketing of any of the resultant products. The Japanese didn't invent the micro-chip—yet there are doomsayers marching up and down this nation's halls of justice screaming that the ability to manufacture computer chips has all but deserted American shores in favor of the Far East.

### A problem with manufacturing

Perhaps lower labor costs have something to do with it. Several years ago it was very popular, and still is today, for companies to have off-shore manufacturing capabilities. This usually was a code word for manufacturing in areas where labor was cheap, but it took more than cheap labor to induce companies to move their manufacturing operations off-shore. There had to be a willing, educated and competent labor force.

Why, then, is Volkswagen, Honda, Nissan and several other companies manufacturing in places like Georgia, Baltimore and San Diego? Why are there textile mills in the Winston-Salem area? Some of these plants have been paying these "outrageous" American wages for some time—they're not new.

I think two things are responsible for this situation. One, there is more to the issue of manufacturing costs than just cheap labor. Secondly, motivated and talented manufacturing people are important to any company's plans regardless of whether they're in the Far East, Mexico or Germany. If companies are interested in Georgia or Baltimore, then there must be some of the right people there as well which makes it a good place to manufacture.

American competitors can't say it's impossible to find capable, technically superior manufacturing capabilities at home. Certainly if Honda and Nissan find them, we can too. Just look at some of the automobiles that are coming out of American factories now. If Americans can make automobiles like that now, then why hasn't it been happening all along?

I have a consistent and persistent feeling that these problems and their solutions are tied to education. "As of 1986, more than 300,000 foreign students were enrolled in American universities, 60 percent of them in technical fields...in contrast to the 300,000 foreign students in American universities only 30,000 American students attend universities abroad. Approximately 3 percent of these students study in technical areas such as engineering, computer science and physics," according to Servan-Schreiber, Jean-Jacques and Simon Herbert in *The Washington Post* last November.

While this data is from 1986, I don't believe it has improved any in the last three years. If people from other countries think the technical training in this country is still superior and are willing to send people here to learn these techniques, why haven't we generated a sufficient number of engineers, technicians, scientists and physicists in this country? Is it because the curriculum is too hard? Is it because easier educations are plentiful or because the perceived rewards in this country for an education in technical sciences isn't great enough?

### Study confirms problem

In a recent study, a statistic reported that in terms of 100,000 college students, the Japanese have 1,000 times as many students in a technical program than Americans do. To put this directly in context, our ability to produce highly trained engineers and scientists is directly related to our ability to produce high school graduates with the requisite interest and talent to fill these slots in the universities. No one can become competitive in the engineering and technology worlds without the proper raw materials and resources, in this case the engineers, scientists and technicians.

In general, students in math and science at the high school level in America score well below the average for the other industrialized nations, such as Japan, the U.K., Sweden and West Germany. That probably explains why there are more people in the technical courses in universities in other countries as opposed to here. If these problems are to be corrected in time for the American economy to regain its proper place, it's time to focus on the root problems in our education systems and do it now. ■

By Wendell Bailey, Vice President  
Science and Technology, NCTA

# Can You Tell the Difference?

---

## PROBABLY NOT! THE QUALITY OF PYRAMID PEDESTALS MAKES THEM SECOND TO NONE

---

Yes, Pyramid pedestals are now better than ever with some differences. For example, paint is electrostatically applied with computer-controlled equipment. This results in a long-lasting—average 25-years in use—finish that successfully meets stringent REA specifications and ASTM testing.

With Pyramid it's easy for installers to open the lid without paint-damaging tools. Convenient hand-holds are part of the pedestal's lid.

Your active equipment will stay cooler. You'll find that Pyramid pedestals provide more ventilation louvers than the competition which allows for maximum heat dissipation.

Next time you need pedestals choose Pyramid and call Hudson for a quote. Pyramid's approved by the major MSOs and is in stock at each of our nationwide warehouses.

So try Pyramid by calling Hudson. We get your order right the first time or we pay the freight!

**HUDSON**  
SUPPLY COMPANY, INC.

*Experience that Cares.*

*Los Angeles*  
1-800-441-0666  
FAX (818) 964-3664

*Chicago*  
1-800-331-2258  
FAX (312) 640-0568

*Atlanta*  
1-800-343-9919  
FAX (404) 979-9622





## Putting it all together

In the past few months, I've written several columns in which I have attempted to provide you with a better understanding of some of the various methods you can use in determining the performance of an earthstation system. For example, we've looked at system G/T, the differences between carrier-to-noise ratio and carrier-to-noise density and how it relates to earthstation receiver IF bandwidth and baseband video signal-to-noise ratio (S/N). This month I'd like to pull it all together by discussing the satellite downlink, and the factors that make up the downlink, in determining the performance of an earthstation system.

The  $C/N_0$  of an earthstation, and hence its ultimate signal-to-noise (S/N) performance can be easily predicted by use of the following formula:

$$C/N_0 = \text{EIRP}_{\text{Satellite}} + L_S + G/T + 228.6 - L_m$$

where  $C/N_0$  is the predicted carrier-to-noise density of the earthstation from which its ultimate S/N is calculated, and G/T is the so-called figure-of-merit of the earthstation. These topics were covered in detail in previous columns. The other terms in the equation however, do require further explanation.

The EIRP, or Effective Isotropic

Radiated Power, of a satellite is a measure of the actual radiated power from the satellite, taking into consideration the satellite transponder's power output from its traveling wave tube amplifier (TWTA), its antenna feedline or coupling efficiency, and the gain of the antenna relative to a fictitious "isotropic" radiator—which is nothing more than a point-source radiator with unity gain.

A typical C-Band satellite will have traveling wave tube amplifiers with power outputs in the 5 watt to 10 watt range. Note however, that since the signal to be transmitted need only be transmitted in one direction (toward earth), and since the signal can further be confined to the small section of the earth for which the transmission is intended (the continental United States for example), the antenna can be made to be highly directive, which is to say with a lot of gain. EIRP's of 35 dBW to 39 dBW (dBW = dB relative to 1 watt) are typical for C-Band satellites today. What this means is that the antenna system onboard the satellite is capable of power gains on the order of 28 dB to 29 dB!

### Loss through 'beam spreading'

The second term in the equation,  $L_S$ , is known as "Space Loss." This can be described as the loss attributed to the signal due to the "beam spreading" that occurs as the signal travels the extreme distance from the satellite to the earthstation. Intuitively it can be thought of as a "spreading out" of the signal and thus a reduction in power density as the signal gets further from its transmitting antenna. In order to calculate  $L_S$ , you need to be able to calculate the slant-range distance between the earthstation and the satellite. This is done through a knowledge of orbital geometry, and the known location, latitude and longitude, of the earthstation. In equation form,  $L_S$  in dB can be calculated as follows:

$$L_S = 185.05 + 10 \log (1 - 0.295 \cos H * \cos L) + 20 \log F$$

where H is the latitude of the earthstation, L is the difference in longitude between the earthstation and satellite, and F is the frequency in GHz of the downlink. As an aside, it is well to note that the apparent increase in path loss with increasing frequency will be offset exactly by an increase in gain of a

given size antenna with increasing frequency. This means that if all else were equal (EIRP, etc.) the same size antenna would be required regardless of frequency.

The next term in the equation for  $C/N_0$  to discuss is the quantity 228.6. Where in the world does that come from? It's an expression, in dB, of Boltzmann's constant which relates the average energy in a molecule to the absolute temperature of the environment. It is usually expressed as  $1.38 \times 10^{-23}$  joules per Kelvin and is a measure of the non band-limited thermal noise floor with which the signal will ultimately have to contend.

$L_m$ , the final term in the equation, is simply the amount of link margin in dB that you would like to provide for your system; allowing for degradation over time, weather variations, etc.

### Predicting the $C/N_0$

For a typical C-Band earthstation with a calculated G/T of 26, a satellite EIRP of 35 dBW, and a link margin of 1 dB, and using a "typical" value for  $L_S$  of 198 dB, we can predict the  $C/N_0$  of the earthstation as follows:

$$C/N_0 = (35 - 198 + 26 + 228.6 - 1) = 90.8 \text{ dB-Hz}$$

As we learned in last month's column, for a receiver operating with an IF bandwidth of 32 MHz, this would equate to a measured IF C/N of 15.7 dB—certainly a very good level of performance.

Ultimately, it's the  $C/N_0$  of the earthstation that will determine the output video S/N performance of your system. In the last several columns, we have seen that there is really only one parameter that you have any control over in order to get the performance that you are seeking, and that is system G/T.

The other parameters in the equation, like Space Loss, EIRP and Boltzmann's constant, are fixed, either by your location or by physics. Note, however, that there are several methods of improving your system's G/T including increasing antenna size, decreasing LNB noise temperature, and, in some cases, decreasing the loss between the LNB and satellite receiver. These will be your primary areas of concentration as you analyze the performance of the downlink. ■

*By Chris Bowick, Director of Engineering, Headend and Earth Station Products, Scientific-Atlanta*

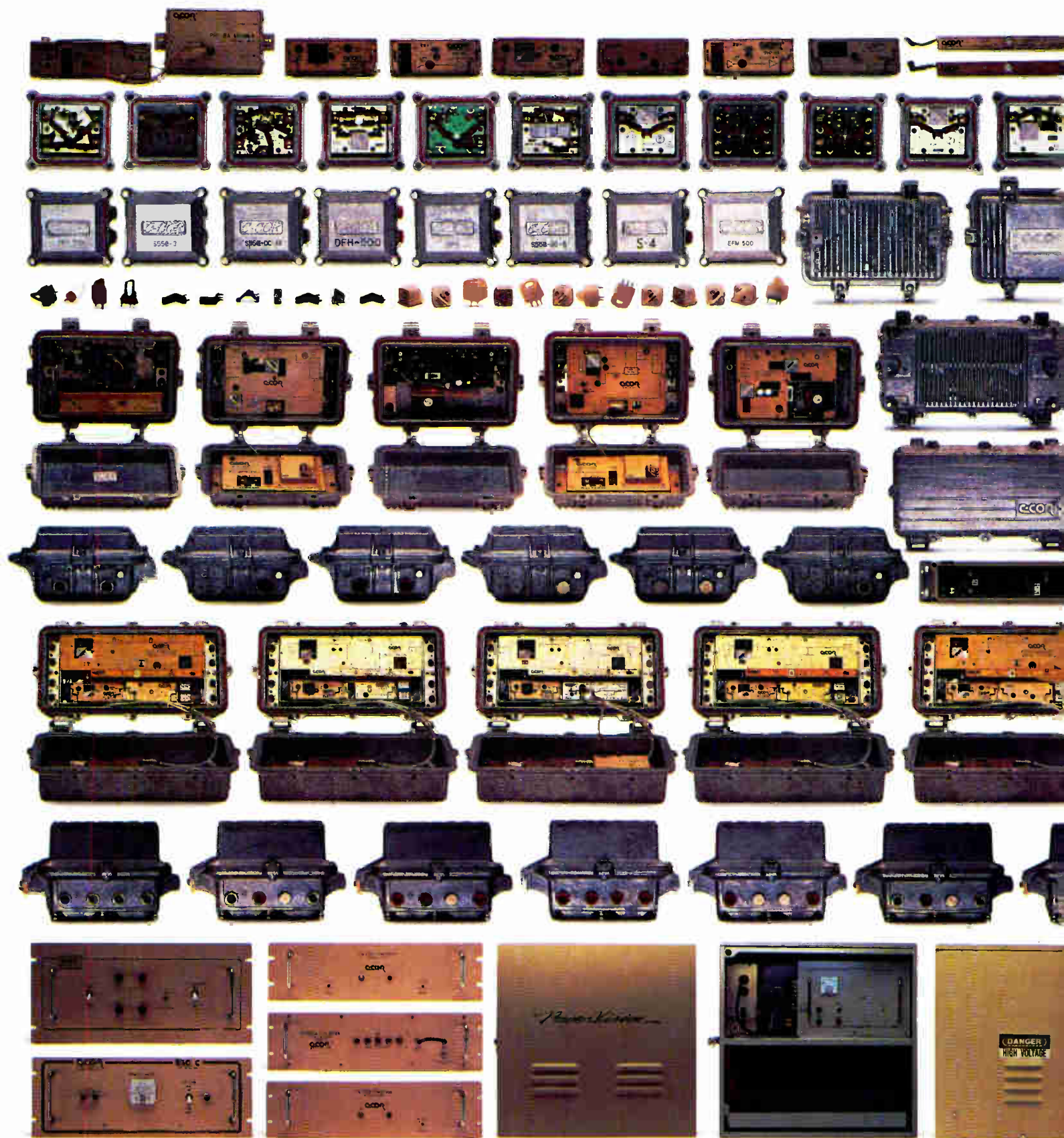

To show all the products we make, we'd need a lot more room.

If you'd like to see our entire amplifier product line, write to: C-COR Electronics Inc., 60 Decibel Road, State College, PA 16801. Or call: 1-800-233-2267, (In Pennsylvania, Call 1-814-238-2461). But be prepared. You'll have to give us a lot of room.

**C-COR**<sup>®</sup>  
ELECTRONICS INC. We're Out To Give You  
The Best Reception In The Industry.



### Must-carry (cont'd)

Last March in this column, I tried to explain how the broadcasters' efforts to get must carry rules reinstated by Congress had been frustrated by issues that had nothing to do with cable television.

As I pointed out, the cable industry has been willing to agree to reimposition of reasonable must carry rules. If a Congressionally imposed must carry requirement might be less vulnerable to judicial challenge than an FCC rule, then NCTA would support a reasonable statute whenever Congress seemed willing to consider one.

Well, Congress finally seemed willing this summer, and the cable industry honored its commitment to support a reasonable must carry law. Once again, NCTA and the National Association of Broadcasters sat down and hammered out a compromise. But there's still no must carry legislation, because NAB couldn't win the support of the Association of Independent Television Stations (INTV) before the window of opportunity—a pending budget reconciliation bill to which the must carry compromise might have been attached—closed.

#### **NAB wants more**

You might think that since the

*By Michael Schooler, Deputy General Counsel, NCTA*

earlier compromise rule, which the FCC adopted, was held unconstitutional, the broadcasters would now be willing to agree to a less restrictive rule that would be more likely to survive judicial scrutiny. In fact, however, NAB insisted on a more burdensome and restrictive rule than the one that NCTA had previously agreed to.

The earlier compromise had placed a ceiling on the number of local signals that a cable operator would have to carry. It eliminated any obligation to carry duplicating network signals. And it provided that, to qualify for must carry protection, a broadcast station would have to meet a minimum viewership standard. Cable operators would not have to carry stations that virtually nobody watched.

This was a reasonable rule that the cable industry and the broadcasters could live with—which is why both industries (including the independent broadcasters) supported the original compromise. This time, however, the broadcasters held out for more. And the cable industry made some significant concessions.

First, the broadcasters have been concerned by the repositioning of broadcast stations on cable systems' channel lineups. The expansion of channel capacity and the large growth in the number of nonbroadcast satellite services have resulted in some cases in the relocation of broadcast stations and other services to different channel numbers. This relocation could conceivably have an adverse effect on a service (broadcast or nonbroadcast) to the extent that viewers initially have to hunt for a service whose channel placement they used to know. It also causes problems if there are several cable systems serving communities in a single metropolitan area. From the perspective of a broadcast station or a cable network, it helps in advertising and marketing if the signal appears on the same channel number throughout the community.

#### **Reason for concern**

These are legitimate concerns, and NCTA agreed, as part of the agreement with NAB, to a provision that broadcast stations have a right to be carried on all systems on their FCC-assigned over-the-air channel number. This would guarantee broadcast stations a uniform channel assignment for all television viewers, whether cable sub-

scribers or not, throughout the community. The earlier compromise between the cable and broadcast industries, which resulted in the last set of FCC rules, specifically did not include any such on-channel requirement.

A second broadcaster request to which NCTA agreed was that cable operators be required to ensure that even new second set hookups have converter equipment, where necessary, to enable reception of all must carry channels. So, where a second set was not "cable-compatible" and local broadcast channels were carried by the cable system on mid-band or super-band channels above the VHF channels, converters would have to be provided. That also was not the case under the old rules.

These concessions ought to have satisfied the broadcasters' concerns, and, indeed, they were sufficient for NAB. But the agreement was conditioned on the additional support of both the Community Antenna Television Association (CATA) and INTV. CATA agreed to the compromise, but INTV did not.

INTV wasn't satisfied with NCTA's acquiescence in an on-channel requirement. They insisted that broadcast stations have a permanent right to remain on the channels to which they had previously been assigned by the cable system before additional channel capacity and new nonbroadcast services even existed.

INTV's rationale for this right has nothing to do with the legitimate interest of broadcasters in establishing channel recognition and uniformity in a community. It's based instead on their perception that, as a general matter, placement on the lower channel numbers, the VHF channels, is more desirable than placement on the higher numbers. Whether this is true or not, especially as TV sets and converters increasingly use random access tuning, is debatable. But if it is true, there's no reason why a UHF broadcaster ought to have any greater claim to a low numbered channel than a cable network like C-SPAN or ESPN. It makes no sense and it's not fair to cable programmers.

So, NCTA could not agree to INTV's demand, which even NAB viewed as excessive, and the deal died for the time being. Opportunities in Congress may arise again, if broadcasters can agree among themselves not to insist on unreasonable provisions. ■

**W**ould you like an easy way to increase cable subscribership? To justify rate increases? To maximize profits? Call the Augat BROADBAND ENGINEERING Upgrade Hotline. Find out how easy it is to add channels at a modest cost with upgrade electronics.

**EXPERT ENGINEERING ADVICE OVER THE PHONE.**

Sherwood Hawley, BROADBAND ENGINEERING Applications Manager, can advise you over the phone how your current equipment can be upgraded to handle your subscribers' demands for more channels. He'll point out the "do's and don'ts" of upgrading. He'll

even provide you with a cost estimate for your system's upgrade. All in about 15 minutes. You end up with nothing to lose and a performance advantage to gain.

**GAIN SUPERIOR ENGINEERING PERFORMANCE WITH BROADBAND ENGINEERING UPGRADE ELECTRONICS.**

BROADBAND ENGINEERING originated the concept of upgrade electronics 14 years ago to extend the life of your CATV equipment—without the unnecessary expense and headaches of system rebuilding. You can still be confident of the technical superiority and reliability of our products and advice. And we back up our upgrade electronics products with a one-year warranty.

For a common sense, cost-effective approach to higher profits and longer life for your current system,



ask for Sherwood Hawley at Augat Communications Group, P.O. Box 1110, Seattle, WA 98111. Call (206) 932-8428 or toll free **1-800-327-6690.**

# KEEPING UP WITH THE DEMANDS OF CABLE SUBSCRIBERS MAKES A LOT OF CENTS.

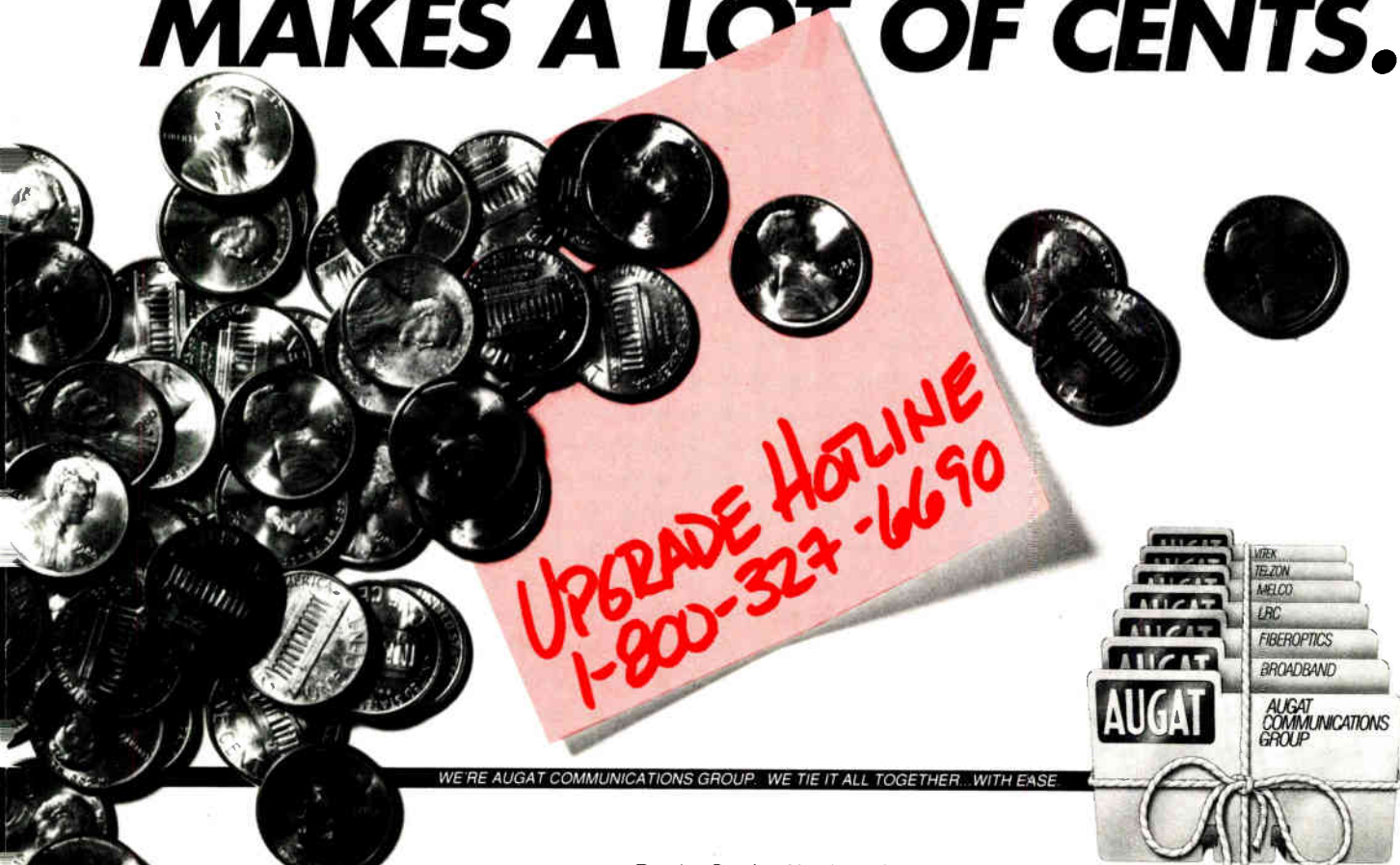

WE'RE AUGAT COMMUNICATIONS GROUP. WE TIE IT ALL TOGETHER... WITH EASE.

### Prepare now for syndex rules

*The NCTA Engineering Committee met at Anixter Cable TV in Englewood, Colorado on August 9, just after the CableLabs fiber optics seminar. Chairman Walter Ciciora opened the meeting and the first item of business was the "Washington update" delivered by Wendell Bailey.*

**A**lthough syndex is currently under court challenge, it will most probably be implemented on January 1, 1990, Bailey reported. Operators should now be preparing lists of programs that must be dropped and ordering the necessary equipment to facilitate the deletion and possible substitution of these programs. NCTA will hold six seminars this fall for cable system general managers to assist in that planning.

The previous deal between the NCTA and NAB on must-carry was undone when INTV, the trade association representing mostly independent UHF stations, refused to accept a key provision—on-channel carriage. The independents wanted to have guaranteed rights to VHF channel assignments instead.

A recent General Accounting Office study showed an average cable bill increase of 14 percent over a 22-month period following deregulation. Although valid reasons for the increase exist, there is some cause for concern given the current "cable-bashing" political climate.

#### US West's activities

Guest speakers Gary Bryson and Earl Langenberg, both of (BOC) US West's cable division, spoke about the supplier relationship that US West wants with domestic cable franchises as well as some technical and business details of their partnerships in U.K. and Hong Kong newbuilds. US West does not envision itself as a program provider or cable industry competitor, but rather a partner in situations where phone services and cable services would combine resources for the purpose of more economical signal transmission in rebuilds and newbuilds across North America.

*By Katherine Rutkowski, Director of Technical Services, NCTA*

#### Subcommittee reports

Craig Tanner of CableLabs spoke on HDTV matters and CableLabs activities. Tanner noted that recently CableLabs made an agreement with the broadcaster-backed Advanced Television Test Center to run some cable-specific tests on ATV proponent systems in tandem with their over-the-air transmission tests. A contract detailing the nature and extent of CableLabs' and ATTC's financial and technical commitments is under negotiation. Dick Wiley, chairman of the FCC ATV subcommittee responsible for testing systems, will set a test schedule when he meets with proponents in late September.

Richard Green, CableLabs' CEO, gave a brief update on other Lab activities. Senior staff are nearly all in place, and all subcommittee, TAC and board meetings have been running smoothly for several months. The Labs' first fiber optic conference was a big success, and the move to the new Boulder office was due to be complete by the week's end.

Mike Jeffers reported that the second edition of the NCTA Recommended Practices text is headed for the typesetter this month and that recent suggested changes to one of the measurement methods had been incorporated. It was noted that the BTSC text will be included in the second edition and will also be available as a standalone reprint. Bailey then reminded the group that this subcommittee's most recent book, a glossary of cable technical terms, was available from NCTA.

Bob Dickinson, reporting on signal leakage matters, said that the NCTA CLI/fly-over seminars were a huge success. Bailey added that sponsored seminars are ongoing—four more are due soon. General discussion ensued on the probable big fines, bad publicity and shut downs due by July 1, 1990 for those systems not in strict compliance.

No improvements were suggested for the draft FCC CLI reporting form (to be filed along with form 325) circulated at the last meeting. Bailey mentioned that the most frequent question at the NCTA seminars was "What's a *system* in the FCC's eyes?"

The advanced signalling and control subcommittee did not have any new business to report.

Larry Nelson of Comm/Scope agreed to take the post of chairman of the ad hoc In-Home Wiring subcommittee.

He sought members and input for the group's charter and goals.

#### MultiPort update

Interim Standard 15A was approved by the EIA in June and is to be referred to as EIA-563 or MultiPort. Van Loan reported that a Western Show exhibit is planned and that RCA and retailers have been very cooperative about supplying operators with customer lists. Testing in a number of cable systems indicates that the decoders work well with MultiPort TVs and where consumers have received the unit they are very pleased. Cable marketing staff are newly enthusiastic about MultiPort. The remaining down side is the fact that VCRs do not have MultiPort plugs as yet.

A new subcommittee of the EIA/NCTA joint engineering committee was formed at the last meeting—program identification. This group, under Bob Burroughs of Panasonic, will establish a standard for identifying programs through vertical interval signals. The subcommittee chairman sought members, noting that one thing the group does not want is a standard that would allow commercials to be cut.

An ID scheme could, however, be used to automate VCR use for taping programs at home, possibly for syndex-related switching, or for program guides. Ed Callahan, in a related move for CableLabs, may start a clearinghouse for all industries' use on how the vertical blanking interval is currently being used.

#### NEC

Since virtually all liaisons were absent, the chairman issued an open call for questions or reports on liaison topics. Hank Cicconi asked that the group seek a requirement for a common lug on meter bases in the next NEC code (1992).

Dave Large asked the group to consider what the industry could save if it were able to power at a lower rate. Today it costs an average of 30 cents per month per subscriber for distribution power. Abe Sonnenschein moved to accept the motion to ask for the NEC change, and the motion was seconded and approved.

The next meeting dates are October 11-12 in Washington and December 7-8 in Boulder. ■



# Turn Truck Rolls Into Bank Rolls With Power Guard And Cable Security Systems



# If You Want To Make Explanations, You Need Power

Your power supply gives you a choice: you can keep trucks in the field servicing equipment or you can roll them out to make new installations. Power Guard is designed to eliminate costly repair hours, so your technicians can be producing revenues.

## Power Guard's Modularity Means Lightning Fast Repairs

From the wiring harness to the circuit boards, Power Guard is completely modular. Every component is designed for fast plug-in replacement in the field, so there's no need to remove and reinstall housings with Power Guard. Getting back on the air

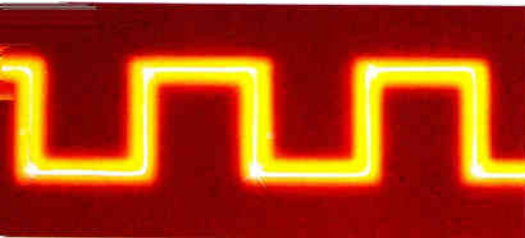

even if lightning damages your wiring will take only a matter of minutes.

The normal power supply weighs only 40 pounds, the standby power module only 30 pounds, so the man in the field can pull a damaged module quickly, safely and restore power in a few seconds. That is what Power Guard is all about, keeping you on the air.

## The Efficiency Expert

Since Power Guard pioneered the long life 90% efficient power supply in 1985, we continue to set the industry standard in reducing power costs while remaining trouble-free. Because our units are rated at actual output, your bottom-line costs will also be less. For maximum efficiency, your power supply should be operated at or near full load. That's why we designed our ferroresonant supplies with different

load ratings, so you can closely match the supply's current rating to the load requirement at each power supply location and save.

Power Guard lets you choose 5, 8, 10, 15 or 18 amp modules. So, when you need 8 amps, use the 8 amp module to get the lowest operating costs with consistent output and high efficiency.

## That Makes You A Cool Operator

Maximum efficiency means that less energy is lost in heat build-up which causes costly burnout and equipment failure. True efficiency is achieved with Power Guard's cool operation, adding years to the life of your power supply (and your field technicians). And the cool operation allows for a smaller enclosure and less pole space.

## Flexibility To Grow On

As your system grows, you can increase your load capacity by swapping out the existing module for one with a higher capacity and plugging in more power in the field.

## Simplicity Spells MTBF

We kept it simple. No unnecessary bells and whistles to reduce reliability. Just productive features that keep your subscribers in the picture—



features to give you the maximum mean time between failures and the minimum down time in case of a failure.

We build a quality product with a powder-coated, all-aluminum housing that will withstand the most severe weather conditions for years of trouble free service. That's why we can give you the longest warranty in the CATV industry today.

## Retro-Fit To Standardize

Our small, highly efficient modular design allows us to Retro-Fit virtually all of our competitors' power supplies, standby and non-standby, while using your existing housings in their current locations. Retro-Fits cost less and take less time to install. They allow you to standardize your entire system with a 90% efficient, totally modular, fully-warranted supply.

With standard equipment throughout your system, your service technicians can make sure their trucks are stocked for in-field repairs eliminating unnecessary second trips. And eliminating the need for cross-training.

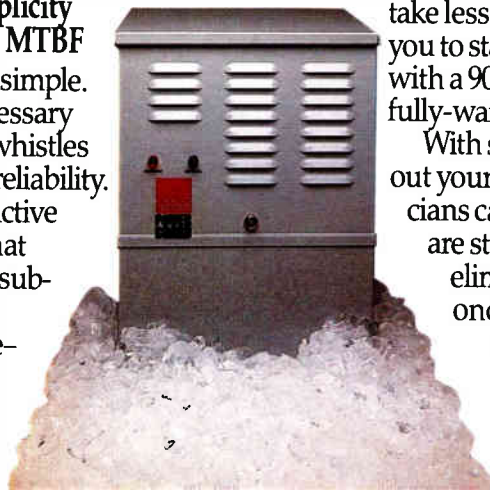

# The Installations, Not Power Guard And The Beast.™



## The Beast Guards Your Connections

The beauty of this apartment box is that it ends theft of service and signal leakage due to tampering...and reduces truck rolls so your technicians can make more hookups, less unproductive audits and repairs.

## The Beast Is Under Maximum Security

We caged the Beast in a box-in-a-box. Stainless steel arc welds eliminate rust and prevent prying. Our 16-gauge aluminized steel remains corrosion-free and outlasts galvanized steel five to one. Coatings withstand high impact for years of use without chipping or cracking.

## SuperLocked To Stay Locked

Developed exclusively for CATV, we built the lock you can't defeat.

Since we introduced SuperLock in 1983, it has remained the benchmark for apartment box security, meeting all

internal and external security requirements for the CATV industry.

The brass tumbler is enclosed in a 16-ounce solid brass housing. All moving parts are brass or stainless steel to remain rust-proof and free-moving. SuperLock is recessed and encapsulated in a deep drawn steel shroud for double protection, in all weather.

## The Key To The Beast's Success

The key to the Beast cannot be reproduced. You control the access to all Beast apartment boxes, simply by logging in and out all keys you distribute to your service technicians.

The key must be in the locked position in order to be removed, so it is impossible to leave the Beast unlocked without detection.

## Installing Without Stalling

Six leads or sixty, we've got your box.

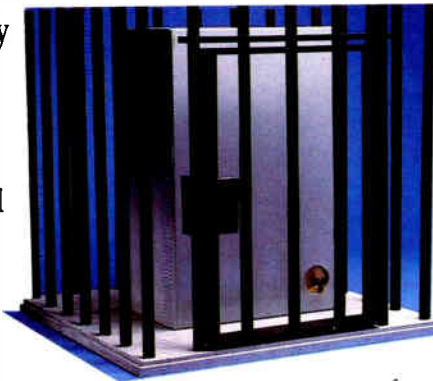

Custom features and options such as knock-outs, mounting plates, organizers, matching locks and ground lugs won't slow us down. Installations of our products are faster, more efficient.

## A Pack Of Protection

Swinging Beast, Beast, Lock Box and Beast II—choose the Beast that's best for you. Cable Security Systems offers a choice of four models to meet your cost and security requirements.

The new Swinging Beast has a non-removable, hinged lid that makes servicing quicker, safer and more convenient. No more lost lids.

Our original model, the Beast, is the industry standard for durability and security in all conditions.

The Lock Box™ is adaptable to almost any locking system. It offers durability and serviceability that's affordable and

may be upgraded to maximum security at any time without rewiring. It can be keyed to the Beast™ with our own 2" solid brass padlock.

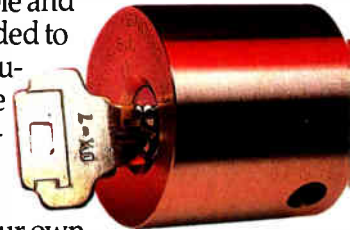

The Beast II has a sliding, retained lid with a self-locking, solid brass lock that can also be keyed to the Beast. The Beast II is a durable system for areas where high security is required.

## Reliance Makes Compliance Easy

Meeting new government regulations to prevent signal leakage is critical to keeping your license—and your customers. Many operators have been spending a lot on costly truck rolls to audit their apartment boxes to detect tampering and theft, which is also a major cause of signal leakage.

Cable Security Systems products give you the security you need to prevent tampering. And knowing that tampering is limited by one of the Beasts, you can eliminate those expensive audits.

So, when you send a truck out, your service technicians can spend their time on new installations not inspections.

Let Power Guard and the Beast truck you to the bank.



# A Powerhouse Of New Ideas In The Cable Industry

Power Guard and Cable Security Systems are innovators in techniques to control CATV operator costs and generate improved revenues. We have brought some of the finest creative minds in the field together to concentrate on products that serve the cable industry. Because we are serious about quality, we have consistently set industry-wide standards of performance including 100% testing for quality control.

## So What Have We Done For You Lately?

In 1974, Jerry Schultz pioneered the first reliable standby power supply for CATV. Today, these very same power supplies are still in use. The Beast was introduced in 1982 as this industry's first true high security apartment box. It is now the industry standard coast to coast.



## So What Will You Be Doing For Me Tomorrow?

Today, we continue our pioneering



company, totally dedicated to serving the cable industry day to day.

Now you have one source of all your power supply and apartment box needs, with the combined resources of Power Guard and Cable Security Systems.

For pricing and information on Power Guard Power Supplies, write:

**Power Guard, Inc.**, 506 Walker Street, P.O. Box 2796, Opelika, Alabama 36801. Or telephone toll-free 1-800/288-1507 or for local calls telephone 205/742-0055.

For pricing and information on the Beast, write: **Cable Security Systems, Inc.**, 801 Fox Trail, P.O. Box 2796, Opelika, Alabama 36801. Or telephone toll-free

1-800/288-1506 or for local calls telephone 205/742-0050.

manufacturing with our state-of-the-art facilities. The brand new 40,000 square foot plant is completely automated, using CAD/CAM to insure precision and consistent quality in every component, from complex circuitry to sheet metal fabrication. We also maintain our own in-house powder paint facility to ensure that all housings are coated for years of durability and weather resistance.

But this is only the beginning: Our engineering staff is busy with exciting new products for the future, and our entire company is dedicated to our goal of remaining the most innovative



800/288-1507



800/288-1506

# Making it through the PPV maze

Lately, the issue of pay-per-view (PPV) has taken a back seat to the "sexy," exciting technologies of fiber optics and high definition television. And while the future promises much for these "front seat" drivers, improved reliability and better performance will not single-handedly increase revenues. To many operators, additional revenue is tied directly to the choices offered the subscriber. For those who want to increase revenues now, or at least keep up with demanding times, PPV is a concept that whispers sweet promises of success.

For these operators optimistically looking beyond poor release windows, high licensing fees and even non-committal attitudes from major MSOs, the PPV scenario is now a maze of questions, decisions and reflections on how to implement a consumer-friendly ordering system. Making it easy for the consumer to spend money is often the first consideration when reviewing available technologies for a PPV startup.

Fortunately, the choices are few. Customer service representatives (CSRs) are almost non-existent as an ordering method. Instead, technologies such as automated number identification (ANI), addressable impulse technology and automated response units (ARUs) are providing a quicker, more efficient means to deal with the consumer's hunger for movies and special events. However, which technology an operator ultimately chooses depends on the system itself—and who you ask.

## The only way

To Wayne Ezell, chief engineer for United Artists Cable of Walnut Creek, Calif., "the (PPV) future rests with ARUs. It's the way to go." Walnut Creek installed the Access Logic Technologies' ARU in December based on its "ease for our customers and cost," says Ezell. Cost was the crucial factor in deciding against an impulse system even though the system has Tocom addressable converters. "We still would have to add on modems and retrain installers," states Ezell. The system also voted against ANI, but that decision was based on lack of verification versus cost. To Ezell, the fact that the

ARU can give several types of messages including a "non-confirmation" if a problem occurred was a significant factor in the final choice.

This type of checking and verification is important to many operators who see ARUs as being more consumer-friendly. With ANI technology, the subscriber calls a specific number which corresponds with an event or movie, the order is confirmed and the subscriber hangs up. With the ARUs, account balancing and credit verification is performed while the subscriber is on the phone. So, if a problem occurs, the subscriber is notified immediately that he will not receive the event.

Another advantage of ARUs is the ability to front-end a phone switch to review trafficking options. For Sacramento Cable, Telcorp System's 6000 Series handled both the phone switch and the PPV aspect. "We made the initial decision because it did PPV," says George Serio, data processing manager for the Scripps-Howard system. "Since we have been 100 percent addressable for the four years we've been in existence, our client base has been used to having a way to order PPV. But at the same time, we wanted to give some breaks to our CSR department on the types of calls that could be handled by a machine."

Sacramento's 6000 series system, which comprises three units totalling 60 ports, has 16 telephone lines dedicated for PPV. The remaining lines are optional and can also pick up PPV calls if necessary. However, Serio still feels the system does not have the phone capacity to handle major events such as Summer Slam. For those events, the system uses ANI in conjunction with the ARUs to handle the volume. Although Serio sees that as an advantage for ANI, the lack of pre-editing calls is again seen as a disadvantage.

"It's kind of a washout there," says Serio. "ANI also has a cost factor that ARUs don't. With ANI, you pay for each call a subscriber makes. Once the ARU is paid for, it pays for itself. It kind of has its advantages and disadvantages on both ends," he concludes.

Ed Milner, vice president of technology for Arlington Cable Partners in Arlington, Va., agrees, but sees a

solution. "We're interested in marrying ANI and ARU together," says Milner. "We'll probably end up merging the advantages of both technologies. From this position, that seems a pretty good way to go."

Milner's system currently uses Interface Technology's software and hardware to perform an ANI process—using the hardware instead of the billing computer to talk to the phone company computer. Interface Technology wrote the program for the Arlington system after Milner decided "it made more sense to apply the programming dollars and system development in the PC arena since that's what the ARU runs on versus the VAX arena which is the billing system," says Milner.

Eliminating impulse technology as a choice because of the capital expenditure, Milner saw the ARU technology as a way to pre-qualify customers on the phone. "We wanted to make it as easy as possible to place an order," says Milner. "ARUs also let us transfer problem customers to a CSR for problem solving. A customer who is not eligible for PPV is a lead."

While also agreeing that there are benefits to marrying ANI and ARU, personnel at Media General, in Fairfax, Va., decided there was enough merit to the idea to implement a program. Although it's not ready yet, within a couple of months the system will be using Phone Base Systems Inc.'s, PayCom, an automated PPV ordering system that combines the speed of an ANI system with the sought-after friendliness of an ARU.

With PayCom, the subscriber calls in, the phone number is captured via ANI and immediately shipped to the billing system for validation where it is tagged. (Normally, PayCom would use the system's controller for validation. Media General's controller cannot currently handle the process PayCom requires.) In the meantime, the subscriber is asked to input a channel number. Once the number is entered, the ARU confirms the title and time of the event. In the case the viewer makes two incorrect entries or has a rotary dial phone, the call is defaulted to a message asking the caller to contact a CSR. If there are no problems, the tag

comes back, there's a match and the subscriber is thanked for the order. The entire tagging and authorization process takes place in less than a second.

"The other thing we can do," says Stuart Segal, vice president of marketing and sales for Phone Base Systems, "is store orders outside of windows if the controller or billing system can handle that. But not every cable system has the capability of doing that."

**A different view**

Though voice confirmation is a definite plus to many, others look at consumer-friendliness in a different light. To many, consumer-friendliness is the ability to order quickly, without intervention and with a touch-tone or rotary dial phone. For Charlie Kennemer, engineering manager/addressable technology, for TeleCable in Virginia, ANI offers all these features and more. Since the system already had Zenith addressability, "the decision to use Zenith Phonevision became a natural choice," says Kennemer. "We wanted something that was fast, reliable and would avoid the incremental capital investment."

A major disadvantage to ARUs, in Kennemer's view, was the drawback of having to use a touch-tone phone. This is firmly echoed by Christine Fry, PPV manager for Cablevision of Baton Rouge, who considered the large subscriber base of rotary phones in the Baton Rouge area before making a final decision. Eliminating impulse technology because it is "extremely cost prohibitive," Fry then viewed ANI as her best option for PPV ordering.

"So it was just a matter of determining what ANI system was going to be the best," says Fry. Her decision was made easier when South Central Bell offered the TicketTaker service at a much lower cost than what Fry could get elsewhere.

To Fry, advantages of ANI are clearly seen in the higher buy rates. With a base of 50,000 addressable subscribers, the system may see 7,500 orders for LSU football games. ANI has also proven to be more cost effective for the Baton Rouge system, reducing costs by 1½ cents per order.

"Theoretically, if you make it easier for people to order 24 hours a day, you get a lot more buys," says Martin O'Keefe, area marketing director for Telescripts Cable in Atlanta, Ga., and another TicketTaker customer. Although Telescripts originally voted against impulse and ARU technology

because of the larger initial investment, O'Keefe also sees merit in the ANI/ARU combination. "ANI has a greater capacity to handle a bulge of local calls in a short period of time," says O'Keefe. "But on a day-to-day operation, ARUs have some advantages.

**Pay per day?**

Although not willing to drop the TicketTaker service, O'Keefe sees the addition of an ARU as an enhancement of customer service—of offering subscribers another way to order movies. Yet, the real question to O'Keefe for the future of automated systems is the ability to grow PPV and the pay television category. "We have to be able to give subscribers more and different options for ordering services that we already have now as well as other services that may be developed," says O'Keefe.

In order to do this, Telescripts has adapted the TicketTaker service to allow customers to order any pay channel, at any time, 24 hours a day, by assigning seven-digit telephone numbers to each service. This packaging of services in different ways is also evident in the current test Telescripts is running, which offers one specific pay service on a day-by-day basis. For \$3.95 a day, a subscriber can order the pay service, which he previously may have been reluctant to do.

As for the technology to implement this type program, O'Keefe doesn't see night and day differences. "The things I'm talking about specifically," says O'Keefe, "can be done with either ANI or an ARU. The biggest difference is the upfront cost of implementing them. And that," he adds, "just gets back to individual prerogatives."

**Cost or quality?**

Because cost is such a crucial factor when making a decision regarding an ordering technology, most systems have opted for something other than the available impulse products. Yet, regardless of its cost, impulse technology is viewed by many as the only true consumer-friendly approach to offering PPV. "It's hard to get any more friendly than the customer deciding right then they want to order a movie and getting instantaneous descrambling when you order," says Larry Lehman, vice president of technology and planning for Cencom Cable Associates in St. Louis, Mo.

Unfortunately, impulse was not implemented in the St. Louis system because of the cost and time needed to upgrade the already addressable system. For Lehman, short of having impulse, "ANI is the best method that is available. It's the closest thing to impulse PPV you can get without having the store-and-forward devices in the home." Regardless, this wasn't a factor in a Texas system that Cencom is currently converting to addressability. "Since we had to get an addressable converter to the home," says Lehman, "we just got the converter to the home with the IPPV module installed."

For Ben Blackmon, general manager for Jones Intercable in Spring Valley, Calif., the decision to go with impulse technology meant *impulse* buying along with customer satisfaction. After spending seven months to determine the best PPV ordering system, the Jones system chose the Pioneer Pulse to handle its IPPV needs. "A lot of people, if they have to stop and think about it, or even if they pick up the phone and get a busy signal, they may not make a second attempt," says Blackmon.

Blackmon also sees the impulse technology as having a built-in safety factor. "If you wanted to watch a movie an hour from now on the ANI system and you order it ahead of time, let's say your kid cuts his foot and you take off the emergency room—the movie plays and no one watches it. This safety factor also eliminates the dreaded "refund" calls common to ANI or ARU technologies."

Another important aspect for the Jones system is "there's no such thing as an overload," says Blackmon. "If everyone in the entire system wanted a particular event, the impulse is always in their converter sitting on top of the TV set, then when we call for collections, we get the data of who ordered the movie."

Still, nothing speaks better of the impulse technology than buy rates. ANI will give you two to three times better buyer rates, whereas impulse generates somewhere between six and eight times higher buy rates (versus CSRs), according to Drew Kaza, director of PPV services for Comcast Corp. The Comcast system started testing with Cable Video Store and the Jerrold store-and-forward system in Willow Grove, Pa., in the summer of 1986. In July of '87, the impulse technology was introduced into a newbuild in Philadelphia, with good results.

"I think we were fairly impressed

# We're bringing the cable industry to its senses.

## Sound

With digital audio we're introducing high quality CD sound.



## Touch

With Impulse we're making pay-per-view more appealing than ever before.

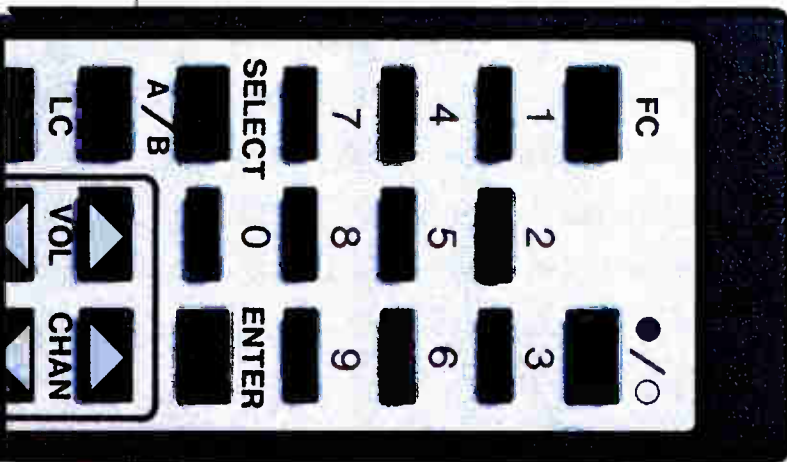

## Sight

With fiber optics we're creating better picture quality.



In the last few years, Jerrold has introduced three new technologies and services that make a lot of sense for the cable industry. Because each has created a new source of badly needed revenue.

Take our Impulse technology and its related service, the Cable Video Store. While Impulse gives viewers the power to order movies at the push of a button, Cable Video Store gives them movies worth pushing for. The result? The fastest growing pay-per-view service in cable.

Fiber optics makes our pay-per-view and everything

else on cable look better than ever by improving picture quality and raising system reliability. It also increases channel capacity. Giving operators the ability to deliver more programming.

Now we're getting ready to launch Digital Cable Radio. A combination of technology and programming that will let us transmit commercial free, digital quality music to any cable subscriber. And an idea destined to do to broadcast radio what cable did to broadcast TV. If you've got a nose for opportunity, call (215) 674-4800.

# JERROLD

W E H E L P Y O U S E E T H E B I G P I C T U R E .

## PAY-PER-VIEW

by the response generated through store-and-forward," says Kaza. "Until that point, I don't think this company was convinced that PPV was really a business until we saw that impulse ordering technology could deliver those kind of buy rates."

"People will go to the effort to purchase something they really want," says Cencom's Lehman. "But where you really see the difference between impulse and one-way is where it's just a regular movie because it's a lot easier and you can truly do it on impulse at the last minute."

Mark Weber, president of Sammons Communications and also a Jerrold impulse customer, also sees advantages to the impulse technology. "ANI can still jam up phone lines and you've got to pay the telephone company," says Weber. "With store-and-forward, it's your option to go to the converter, have it call you back and tell you what's been purchased, therefore your phone lines do not need any increase in size or anything else."

### More to it than impulse

Repeating O'Keefe's thoughts of giving the subscriber more ways to offer

pay television, Larry Cochran, PPV administrator for Cox Cable in Macon, Ga., also sees a side benefit to the impulse system. Choosing Oak Communication's Sigma converter for its PPV ordering system, Cochran felt there were other features that could be incorporated with the PPV system. "The main feature," says Cochran, "is that subscribers can do an immediate service upgrade on the system. With the press of a button on our remote control unit, a pay service can be ordered within 30 seconds without a phone call."

A different type of feature sought by Cox Cable in Jefferson Paris, La. concerned volume control, according to Jerry Strasser, plant operations manager. The system originally started offering PPV in 1984 when the technology was "the old self-destruct test," says Strasser. "You'd have a decoder with a battery and you'd pull the tab and the battery would activate the decoder. It would be good for an event as long as the battery lasted and then it wasn't any good."

From there, the Cox system went to addressable converters. To get the volume control and still maintain good picture quality, the system chose Scien-

tific-Atlanta's 8590 and 8595 converters. "Originally," says Strasser, "the volume feature, which we wanted to provide to our customers, had a tendency to degrade the picture. We were interested in a converter that provided impulse and volume control with a good picture."

Because the impulse technology often requires the converter to be hooked to the phone, many subscribers either don't want, or physically cannot have the impulse system connected. For those subscribers, both Cox systems in Macon, Ga. and Jefferson Paris, La., offer an ARU service to their customers. This type of combination technology, as with the ANI/ARU linkup, is beginning to gain acceptance with many operators. However, to many operators, the future of PPV does not rest with the ordering system.

"The future of PPV is going to be totally product driven," says Telecable's Kennemer. And Milner agrees. "No matter how the engineers can provide miraculous ordering technologies," states Milner, "if the programming isn't there that people want to watch, it's not going to make any difference." ■

—Kathy Berlin

# Our Line Of Distri

Today the challenges of taking your delivery system further are enormous. Higher signal quality. More channels. Better reliability. Flexibility. That's why Scientific-Atlanta has developed the Total Systems Architecture™ approach to provide you with the tools to advance your delivery system and protect your investment.

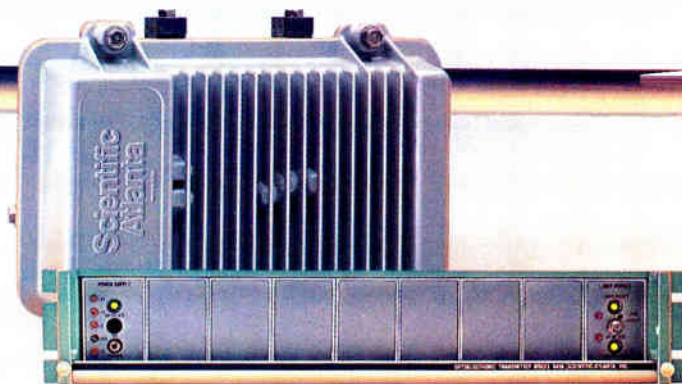

## FIBER OPTICS.

The ultimate in signal quality, with built in optical isolator and RF switch. Capability for up to four laser transmitters and three receivers. It's compatible with all coax systems. You can depend on Scientific-Atlanta's design experience and support.



# Impulse Pay-Per-View Ordering Systems

Company	Product	Cost	IPPV Application
<b>Access Logic Technologies, Inc.</b> (817) 877-5629 Joe Sigler	The COMMAND CENTER	\$18,000 Base unit	Base ARU system expandable from 4 to 48 ports, allows use of Touch-Tone, Voice Recognition, ANI, DID type lines. System is flexible to allow growth and add future modules as needed.
	Subscriber Attendant Center Administration Attendant Center Message Center Mail Center Data Center Auto-Guide Impulser		Automated Attendant for Cable Systems Subscriber Calls Automated Attendant Functions for Cable Administration Offices Allow voice messages for specific departments or personnel Internal and External Voice Messages Touch-Tone and Voice Recognition access to Billing System Data Voice Event Guide of whats showing for Pay-Per-View, eliminates subscribers use of Event Numbers, allows subscribers to make on-key entry for selection of events available to order. Auto dialer device that works in all phone types and allow subscriber to select channel number of event to order.
<b>Business Systems, Inc. (BSI)</b> (803) 297-9290 (800) 424-0101 Israel Sandler	Impulse Pay Per View	N/A	BSI's Impulse Pay Per View software provides a means to define PPV events, process PPV orders, report on PPV orders, charge subscribers for events received, and maintain a history of PPV orders. It also features daily uploads of orders from the addressable controllers. BSI's Impulse Pay Per View system is designed for systems that utilize the IPPV capabilities of manufacturer's addressable controllers. Interfaces for IPPV include major manufacturers such as Jerrold, Tocom and Scientific-Atlanta.

# tribution Products Will

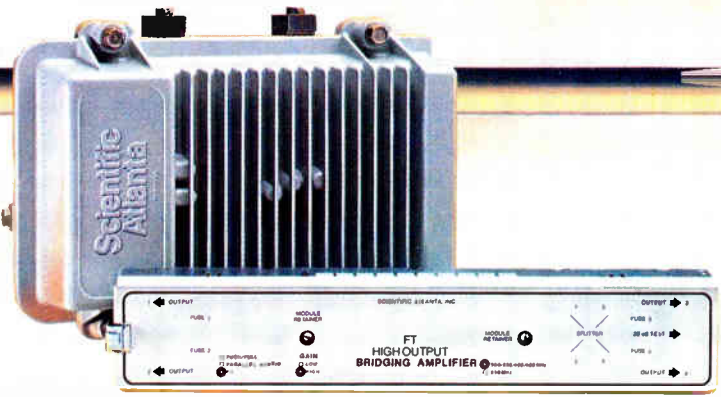

## FEEDFORWARD AND AT AMPLIFIERS.

Get a full line of "drop-in" upgrades. Mix and match to grow capacity more economically. AT outdistances conventional power doubling, stretches spacing and maintains high picture quality. Feedforward amplifiers have over 99% reliability, earning us the industry's largest installed base.

## FT BRIDGER AND LINE EXTENDER.

Super trunk performance out to the feeder, with output needed to deliver up to 27 more channels without respacing. FT takes high quality AT, feedforward, or fiber signals to the home. With twice the output of power doubling, half the distortion and 27% less power consumption, FT runs cooler and more reliable.

## PAY-PER-VIEW

BSI also interfaces with the Telecorp Cable TV Audio Response Unit System 6000 (ARU Ordering System). As an optional enhancement to the Basic Direct Addressable Interface and the Pay Per View Reports and Manual Order Entry System, it provides an automated PPV ordering method by accepting orders placed through the ARU. The system tracks rejected ARU PPV orders by reason.

Pay Per View through Automatic Number Identification is another optional enhancement. In conjunction with telephone company technology, it provides an automated PPV ordering method for all subscribers with a home telephone and addressable converter. The system allows the operator to assign the telephone numbers used to order events. It also tracks rejected ANI orders by reason.

<b>Cable Data</b> (916) 636-5660 Bob Hughes	Teleclerk 386 - Audio Response Unit	\$32,750 for 8-line unit. (Bi-Lingual) 32 phone line capacity	Hot Ticket PPV (No event number necessary), normal PPV ordering and ANI integration. Other capabilities: voice recognition, voice mail, interactive outage tracking, box reauthorization, technician functions (automated dispatch), account balance inquiry and outbound calling applications.
<b>Cable Services Group</b> (402) 399-7475 Donna Pennington	Management Information and Subscriber Billing Systems		Interface with the following IPPV systems: Zenith, Scientific Atlanta, Jerrold, Tocom, Pioneer
<b>Computer Utilities of the Ozarks, Inc.</b> (501) 741-1616 (800) 541-8825 Herb Lair	Cable/I	Starts at \$2,950 Multi-user with IPPV \$7,500	Zenith PM System, Jerrold AIO, ToCom, and S/A
<b>Creative Management Systems, Inc.</b> (415) 362-1345 Gil Jacobs	System 1 - IPPV Features	CMS software costs are one-time charges based on options selected—there is no charge for on-going usage.	Marketing features—all PPV events Operation features—Account Balance Inquiry, Converter Re-authorization, Converter Swaps, Installer/Tech Check-in, Work Order Completion, Non-pay Re-authorization

# Take You Further Th

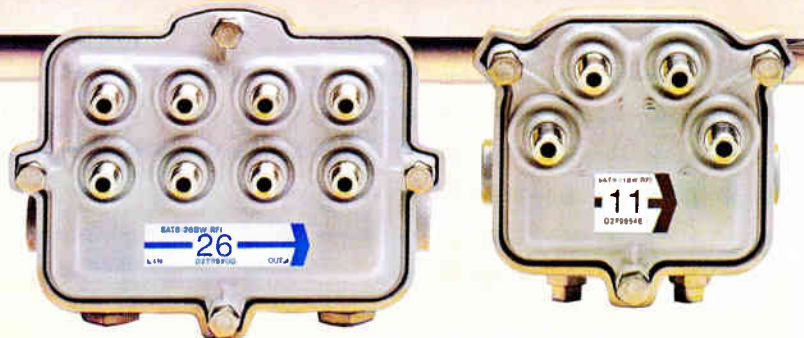
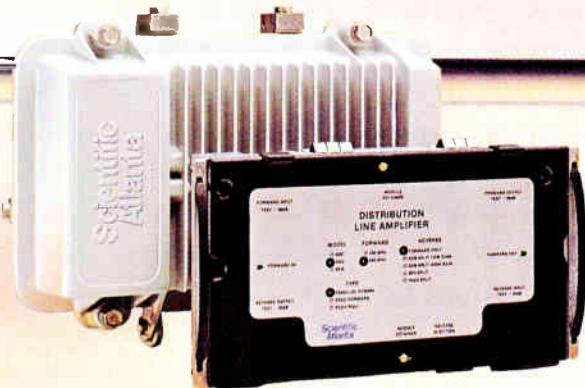

### 4-PORT DISTRIBUTION AMPLIFIERS.

Total flexibility is the key. Use a distribution amplifier for the trunk or feeder. Choose: push/pull, parallel hybrid or feedforward with bandwidth options that range to 550 MHz and beyond. Amplifier housings add flexibility, with internal splitters and AGC options.

### TAPS AND PASSIVES.

Easy to install and almost impossible to break. Solid brass ports and powder based coating protect against corrosion. Ports are lengthened to accommodate locking terminators, security shields or weather boots. Modular design allows for easy upgrades and backward compatibility.

## PAY-PER-VIEW

<b>Great Lakes Data Systems, Inc.</b> (800) 882-7950 Lon Rosado	IPPV/PPV Control System \$2,500	The GLDS IPPV/PPV Control System is an add on product that is used in conjunction with the GLDS Enhanced Cable Billing System. The IPPV/PPV package is available for use with Zenith, Tocom, S.A. and Pioneer addressable systems. In addition to supporting IPPV operations on multiple channels and multiple head-ends, this system also allows for manual, ANI or ARU order processing. One of the unique features is the ability to do PPV on S.A. systems without a System Manager and the ability to control hundreds of events on the Pioneer M1B controller that has a six event limitation.
<b>Information Systems Development, Inc.</b> (305) 753-8220 Paul Barre	CableMaster Customer Management & Billing System on IBM AS/400. Variable depending on number of subscribers.	IBM AS/400 Platform. System handles orders as follows: (A) ANI (via CableMaster Interface or via Addressable Vendor Interface); (B) Impulse Order; (C) ARU Orders; (D) CSR Orders. CableMaster will automatically download addressable equipment scheduler. CableMaster handles 99,999 events with full packaging capabilities. Variable pricing schemes to support marketing activities. Rich in data base functions with extensive query capabilities—Marketing oriented. Full Accounting Interface.
<b>Interface Technology, Inc.</b> (314) 434-0046 Karen Zienta	Cable-IT \$25,300 for 4-line system	Basic system provides Pay-Per-View application with an interface to a billing system. Optional title service is available to produce vocabulary for monthly Pay-Per-View titles or cable operator can prepare themselves. Basic system provides management reporting for system activity. Cable-IT also features Hot Order, for quick ordering of big events and Ticket Window that lets subscribers select for the next available events.
<b>International Technology Group Inc.</b> (609) 848-3627 Paul Goldy, Jr.	The ITG Cable Manager A complete ITG Cable Manager system costs from \$.50 to \$.10 per subscriber per month, depending on the number of subscribers and options purchased from ITG Inc.	The ITG Cable Manager does not yet support impulse pay per view. The current offering employs an efficient operator entered authorization for each subscriber to an event. The system supports escalating event pricing and post-event billing system updating from either an addressable system upload or from the billing system's own files. Extensive marketing analyses of PPV activities are provided.

# an Anyone Else.

Our Total Systems Architecture™ approach to CATV means we can take you further than anyone else. And we'll get you there more efficiently, reliably and, in the long run, more economically.

At Scientific-Atlanta — we do it right.  
 Call or write Scientific-Atlanta  
 Dept. AR, P.O. Box 105027  
 Atlanta, GA 30348 1-800-722-2009.

## Scientific Atlanta

Our customers are the winners.  
 Reader Service Number 16

## PAY-PER-VIEW

<p><b>Jerrold Division, General Instrument Corp.</b> (215) 674-4800 Dan Moloney, Director, Product Marketing</p>	<p>STARVUE (RF Return) STARFONE (Telephone Return)</p>	<p>List Price: \$15 STARVUE, \$20 STARFONE</p>	<p>Store-and-forward technology. Subscribers are pre-authorized to purchase events. Purchases are completed at the push of a button. Collection of information performed either via RF or telephone path on a non-real time basis.</p>
<p><b>Oak Communications Inc.</b> (619) 451-1500 Tony Wechselberger, Senior Vice President/Domestic Operations</p>	<p>Cable Sigma Addressable Decoder Converter</p>	<p>Internal \$11.00 External \$16.00</p>	<p>Oak's "ASAP" store and forward IPPV employing either/both telephone or RF two-way cable return. Capable of automated standard pay upgrades, home merchandising, polling/ratings, real time interactive functions, and IPPV on backwards compatible (Zenith, S.A., Jerrold, Total Control) channels.</p>
<p><b>Perception Technology Corp.</b> (800) PTC-3002 Bob Hailer</p>	<p>Vocom 20, Vocom 30, Vocom V</p>	<p>\$18,000-\$112,000 (Base configurations)</p>	<p>Voice response systems utilized for order entry, etc.</p>
<p><b>Phone Base Systems Inc.</b> (703) 893-8600 Stuart Segal, Vice President Marketing &amp; Sales</p>	<p>PayCom<sup>SM</sup></p>	<p>No capital investment; pricing per order</p>	<p>PayCom, an automated PPV order system, reduces the length of an order by automatically identifying a subscribers home telephone number. The service combines the speed of ANI with the user-friendliness of a sophisticated voice response system. PayCom also allows for targeted messages to be automatically delivered to PPV orderers on a selective or every caller basis, promoting and soliciting orders for upcoming events and pay services.</p>
<p><b>Pioneer Communications of America, Inc.</b> (800) 421-6450 (201) 327-6400 Inside NJ David Nicholas, National Sales Manager</p>	<p>BT-H610 Telephone Return PULSE module BT-F610 Cable Return PULSE Module</p>	<p>BT-H610 \$25.00-\$27.00 BT-F610 \$24.00-\$26.00</p>	<p>For impulse pay-per-view (IPPV) applications, Pioneer offers PULSE, an integrated IPPV option for the BA-6000 series addressable converter. The BA-6000 can be upgraded to two-way addressability by utilizing either telephone or cable (RF) return PULSE modules. Based on years of experience with two-way addressability, the BA-6000 with a PULSE option offers cable operators the advantages of IPPV ordering technology, viewer statistics collection and opinion polling, among many other features.</p>
<p><b>Scientific-Atlanta</b> (404) 925-5048 Andrew B. Meyer, Market Manager</p>	<p>Addressable set-tops with Impulse pay-per-view. Both Telephone &amp; RF-Return.</p>	<p>Telephone IPPV modules \$25.00 additional cost to the addressable set-top. RF-Return IPPV modules \$30.00 additional cost.</p>	<p>System wishing to upgrade to impulse pay-per-view can install an impulse module into an existing Scientific-Atlanta addressable set-top or a new set-top can be purchased with the module already installed. A system can utilize telephone &amp; RF return in one system as well as regular pay-per-view via CSR's, ANI or ARU.</p>
<p><b>South Central Bell</b> (205) 321-3413 Cathye McDonald</p>	<p>TicketTaker<sup>(SM)</sup> service</p>	<p>\$.175 per call to \$.25 per call, based on total monthly volume</p>	<p>TicketTaker is an automated pay-per-view order entry service that uses the Automatic Number Identification (ANI) capabilities of the switched telephone network. ANI of customer's line cuts down possibility of incorrect or fraudulent orders; electronic ordering is convenient and fast for customers.</p>
<p><b>Telecorp Systems, Inc.</b> (800) 334-9907 (404) 449-6991 Inside GA Dana L. Webster</p>	<p>System 6000 ARU</p>	<p>Starting at \$26,500</p>	<p>The System 6000's windowing technology creates "windows" of time during which only one event per channel can be ordered. When a subscriber dials the ARU, he is presented with the name, starting time, channel and cost of each available event, and is given the option to order by pressing a number on his touch-tone telephone. A direct wire link with the host computer billing system provides immediate order verification so that the caller knows, before hanging up the phone, whether or not he will receive the event.</p>
<p><b>Triple Crown Electronics Inc.</b> (416) 629-1111</p>	<p>Complete Impulse Pay-Per-View Systems designed specifically for hotels, and similar applications.</p>		<p>Triple Crown Electronics designs, manufactures and supplies complete Hotel Pay TV and Guest Video Services Systems for operation with North America and International TV Formats. Between 1 and 15 channels can be controlled for Preview Times, 31 Day Schedules, Sales and Marketing. Data and Access Restriction. Additional Amenities are available such as In-Room Video Checkout, Message Amenities, Emergency Broadcast and direct connection to the host building's Property Management System (PMS).</p>
<p><b>Zenith Electronics Corporation</b> (312) 391-7702 Robert Cunningham</p>	<p>Z-View/PM-Pulse/ Phonevision</p>	<p>N/A</p>	<p>Zenith offers a full range of systems for IPPV. Z-View is a real-time, two-way addressable system offering fast, reliable pay-per-view. PM-Pulse is also a two-way system but utilizes store-and-forward technology. All Zenith addressable systems can profit from IPPV with the exclusive Phonevision ANI interface system.</p>

# YOU CAN GET IT ALL

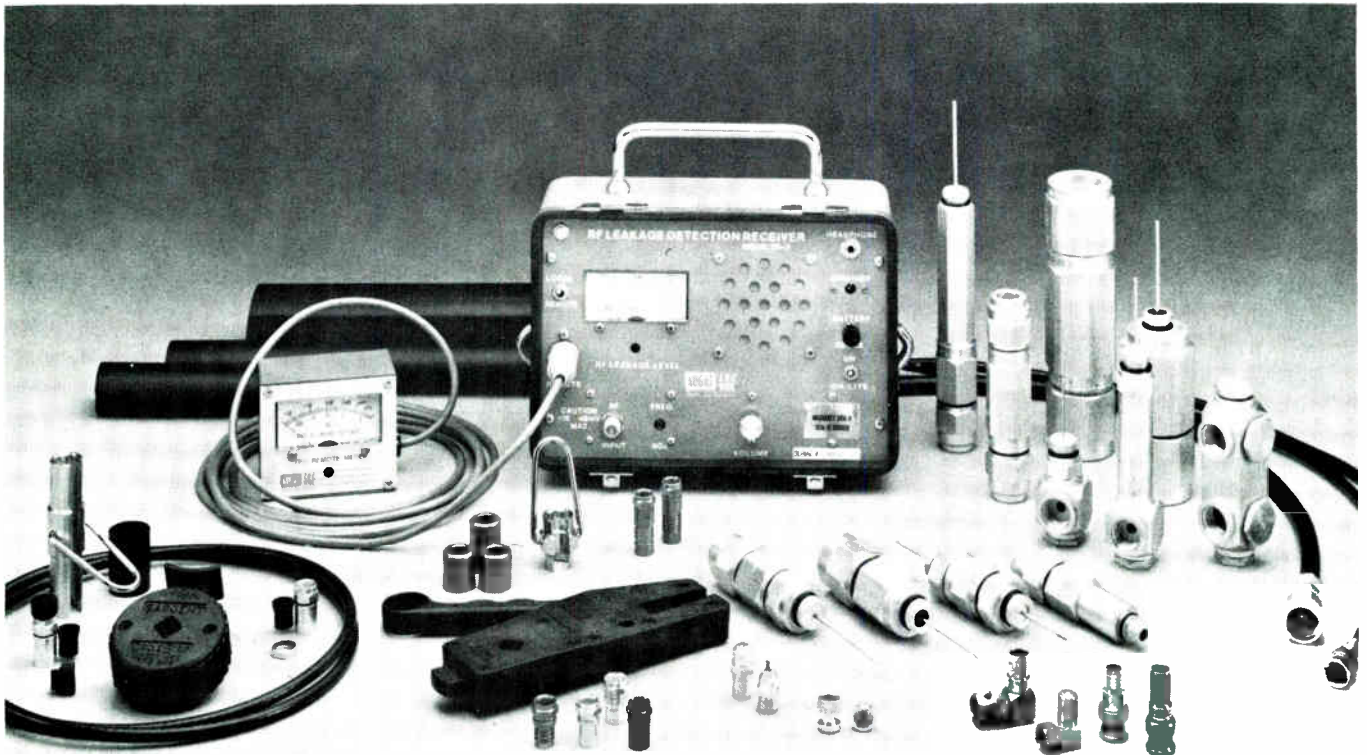

## WITH LRC!

**EASY INSTALLATION.  
RELIABLE PERFORMANCE.  
PROVEN DURABILITY.**

Whatever your CATV needs, look to LRC's complete line of quality engineered products — we've got it all!

- Snap-N-Seal™, the exclusive "F" Connector that requires no crimping! The 360 degree compression on the cable jacket ensures a complete radial seal, virtually eliminating RF leakage. Triple seal gives maximum protection against the environment.

- A convenient combination tool to handle both cable prep and installation. Plus weather caps to protect disconnected drops and security shields.

- 3-Piece "W Series" Connector. Offers no-twist center conductor,

guess free positive stops, center conductor cutting guide. The 30 dB minimum return loss has been extended to 1 GHz on pin and splice connectors to accommodate future channel expansion. And, it's Keyless! The keyway has been eliminated.

- 2-Piece "K Series" Connector. Our 2-Piece offers you the same convenience and durability as the 3-Piece, with 2-inch pin, positive stops, and patented auto-seize mechanism.

- TR-1 Tracer Unit. Everything you need to meet revised FCC codes in one package! Our full range of accessories includes probe adaptors, strap, wall mount, charger, dipole antenna with 10 ft. of cable, headphones, 8 and 20 dB pads, tuning tool and more. And

now you can order our remote meter. It's easy to use and easy to read. It plugs into the TR-1 and takes equivalent readings of 10 u/Vm or less at 100 feet.

We've only highlighted a few of our products, but at LRC, we have it all! Call us for details on these and other products at 607-739-3844 or 1-800-332-8428 or write Augat/LRC Electronics, P.O. Box 111, Horseheads, NY 14845.

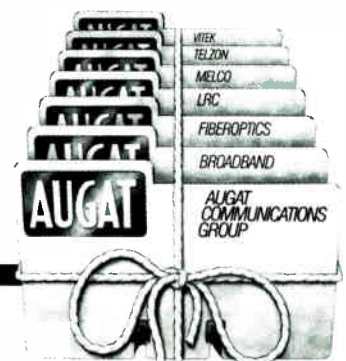

WE'RE AUGAT COMMUNICATIONS GROUP. WE TIE IT ALL TOGETHER. WITH EASE.

# The renewed interest in tech training

**A**mong all the issues facing cable television today, none is more important than technician training. While regulatory issues, the rise and fall of competitors, new revenue streams and other items fill cable system operators' agendas on a day-to-day basis, the lack of highly trained personnel could threaten the future of CATV like nothing else.

For it is technical excellence that the greatest challenger—the telephone companies—will compare itself to CATV to the consumer. Already telcos are taking to the airwaves with commercials boasting such attributes as fiber optics or a guarantee of service restoration should the network ever fail. Cable will have to compete if it hopes to remain the provider of entertainment (and certainly other) services to the home.

## Industry knows its limitations

Right now, cable TV is light-years behind the RBOCs when it comes to the quality of technicians. While that should be a scary thought, even worse is the fact that the industry knows it. According to *CED's* annual salary and job satisfaction survey (August 1989, p. 34) techs complain about the lack of training they receive, while their managers regularly lament the fact they cannot find qualified technical personnel when they have staff openings.

Clearly, if the industry cannot locate adequately trained techs, they have to train them internally. But, like most issues in CATV, those training methods vary considerably from MSO to MSO. Some are aggressive while others leave it to the technician to decide how much education he ultimately wants to have.

Probably the most aggressive MSO is Jones Intercable, which has spent thousands of man-hours developing and honing high-tech interactive training programs, writing job descriptions and streamlining the training process.

The process starts with the Qualified Installer Program, which Jones instituted more than a year ago with great success. The QIP establishes a set of guidelines that are to be followed by

installers and technicians who work with drops in all Jones systems across the country. According to Pam King, technical training coordinator for Jones, the program consists of: an installer kit, which includes the QIP manual and handouts; a statement of commitment to quality workmanship; a series of meetings to review the program;

Clearly, if the industry cannot locate adequately trained techs, they have to train them internally.

written tests; five field skill evaluations, or quality checks, of actual installs; performance reviews; waiver options for program variations; and plans for requalification every 18 months.

## Developing a standard

The goal of the program was to create one drop installation procedure for all Jones systems and make the installer responsible for the technical integrity of each install. The results of the program have been nothing short of outstanding; service call rates for all Jones systems dropped from 3.7 percent in January 1988 to 2.5 percent a year later. With truck rolls costing anywhere from \$25 to \$35 each, the reduction in service calls translates to huge cost savings.

From the outset, Jones executives centered their training program around three philosophies, according to Ron Christensen, vice president of human resources: that the supervisor is the best trainer; good training is cost-

effective and that training should have an element of fun and utilize new technologies.

An example of the latter would be the laser-disc based interactive training programs Jones has developed over the past year. So far, discs aimed at training customer service reps have been completed and technical programs are being developed by a Jones subsidiary. Because of the high cost of developing discs (about \$200,000 each), Jones works with other MSOs to share costs, says King.

Because the industry is maturing while at the same time becoming more sophisticated, Jones execs say it's important techs receive training in the most efficient way possible. They believe the decentralized approach—via interactive laser discs—is the best method.

## Rewarding hard work

"This (program) will increase the number of promotions from within," predicts Christensen. "If we can train someone in half the time to be a good installer...the savings are tremendous." King adds: "Training was done differently before, depending upon each system. Now the basic building blocks will be the same."

The operator most well-known for taking exactly the opposite approach has been American Television and Communications, which has operated its National Training Center in Denver for several years. That facility's curriculum, based on a cooperative venture with the Cleveland Institute of Electronics and consisting of four two-week classes and CIE courses leading to an Associates Degree, has remained essentially the same since 1981, says Ron Wolfe, training center manager.

For those who don't plan to get a degree, the training center simply offers courses to technicians to allow them to acquire knowledge and perform their jobs better. In addition to the Tech I, Tech II, Tech III and Chief Tech/Engineer classes, the training center offers several two-, three- and five-day courses and seminars. For example, a new Service Tech class has

# BY THE YEAR 2000, ALL AMPLIFIERS MAY BE THIS GOOD.

**With the  
Magnavox  
Spectrum  
2000 Series  
you don't have  
to wait that long.**

Introducing the shape of the future in amplifiers. Developed through extensive research, the new *Spectrum 2000* is the most technologically advanced amplifier series available. Inside and out.

Designed to shield your broadband electronics from the merciless elements, the *Spectrum 2000* housing\* is unlike any other. Computer designed convection fins provide superior heat dissipation in either vertical or horizontal installations—keeping internal modules cool. Plus, our improved weather and RF seals lock out external elements.

Our extended 5/8 inch ports are standard and are designed to accept a heat-shrink seal where the cable enters the housing. And our optional right angle ports even eliminate the need for 90° and 180° connectors making it a snap to mount in aerial, vault and pedestal installations. For ease of maintenance, the cover is reversible and always opens

\*Patent Pending

in the most convenient way. And it closes tight so no special tools are needed.

The *Spectrum 2000*'s 600 MHz 2-way chassis features improved surge characteristics for protection against transient power surges and color coded fuses for quick identification and easy replacement.

Available in a variety of bandwidths and bandsplits for worldwide usage, the *Spectrum 2000* amplifier is compatible with all Magnavox modules manufactured since 1972.

Bring your broadband system into the next century with the *Spectrum 2000* amplifier series. Call your Magnavox representative for more information.

## MAGNAVOX

**CATV SYSTEMS, INC.**

100 Fairgrounds Drive, Manlius, NY 13104  
(315) 682-9105 Fax: (315) 682-9006  
1-800-448-5171 (In New York 1-800-522-7464)

## TECHNICAL TRAINING

been added and plans have been made for an Advanced Service Tech course, says Wolfe.

In the past, ATC technical personnel from all over the country would come to Denver if they wanted more information on subjects like fiber optics, signal leakage or tests and measurements. While that worked well for those who could make the trip, there was always a lingering doubt about how much information trickled down through system-level technical staffs. That's why, right now, systems are identifying specific persons to act as local trainers to pass along the latest technical information to new hires and lower-level techs and installers, says Wolfe.

By identifying and certifying field instructors, ATC exploits several built-in advantages. Although Wolfe understands that the concept won't work for all the courses the NTC offers, advantages include accessibility to personnel, knowledge of system specifics and staff, and significant cost savings to each division.

### Not retrenching

Does this mean ATC is moving away from the centralized style of training?

Not entirely, says Wolfe. For example, the NTC will continue to act as a clearinghouse on safety information. The staff will review tapes and programs and consult with the various ATC divisions and establish new training guidelines. Wolfe's ultimate goal is to have access to everything a system would need when it comes to safety information.

Judging from past performance, it seems clear that CATV technicians do not pursue the cooperative Associates Degree program through the NTC. Wolfe says that about 90 persons per year make the trip to Denver and complete the Tech I portion of the program, but then seem to disappear because fewer than 20 people complete the Tech II portion. And it gets worse. In an average year, only 12 to 15 students finish Tech III and maybe eight complete the Chief Tech/Engineer course.

Wolfe says that could be explained because education isn't a guarantee of advancement. "A lot of (advancement) is hinged on training," says Wolfe, but it may not be a linear relationship. Training will make a person ready to take the next step faster, but there is some reliance on job experience, too,

especially when it comes to supervisory positions, he says.

A new course, called Technical Operations Management, will be debuting sometime in 1990 and promises to address some of these issues, Wolfe says.

Training doesn't necessarily guarantee advancement—techs need to be willing to relocate to where the job is, says Wolfe. "There's only so much room for upward mobility. I think that's always been true in this industry, I've moved five times in the last 11 years."

But there is hope. ATC, like most MSOs, makes every effort to fill positions from the inside. That policy demonstrates to all personnel that there is a possibility of upward mobility and, Wolfe says, it's ultimately less expensive to grow employees rather than purchase them.

### Harder to move up

"I'd say the rate of upward progress is probably less than 10 years ago," due mainly from industry consolidation, Wolfe adds. "But I think there's still a good outlook for the future of this industry" especially when it's com-



**SOLID  
STRENGTH AND  
PERFORMANCE**

**The tools of choice by Cable Prep**

- Hand-crafted from precision parts
- Proven in the field for durability
- Made in the U.S.A. • Competitively priced
- Today's CATV toolmaker, CABLE PREP

**We make your job easier!**

Copyright 1989 Ben Hughes Communication Products Co.

**GP cable prep**  
BEN HUGHES COMMUNICATION PRODUCTS CO.  
207 Middlesex Avenue, P.O. Box 373  
Chester, Connecticut 06412-0373  
(203) 526-4337 FAX: (203) 526-2291

## HEADEND EQUIPMENT REPAIRS!

- Receivers
- Processors
- Strip Amps
- Field Meters
- FCC Offset Modification
- LNC

All makes and models repaired.  
10-15 working day turn around  
complete repair reports  
90 day warranty

**800-346-3083**

Call for quotes on distribution and  
S.A. addressable converter repairs.



**Midwest  
CATV Engineering**

1818 N. Went Street, Mishawaka, IN 46545



# FLEX-CON.™ IT MAKES BURIED CABLE PROTECTION EASY.

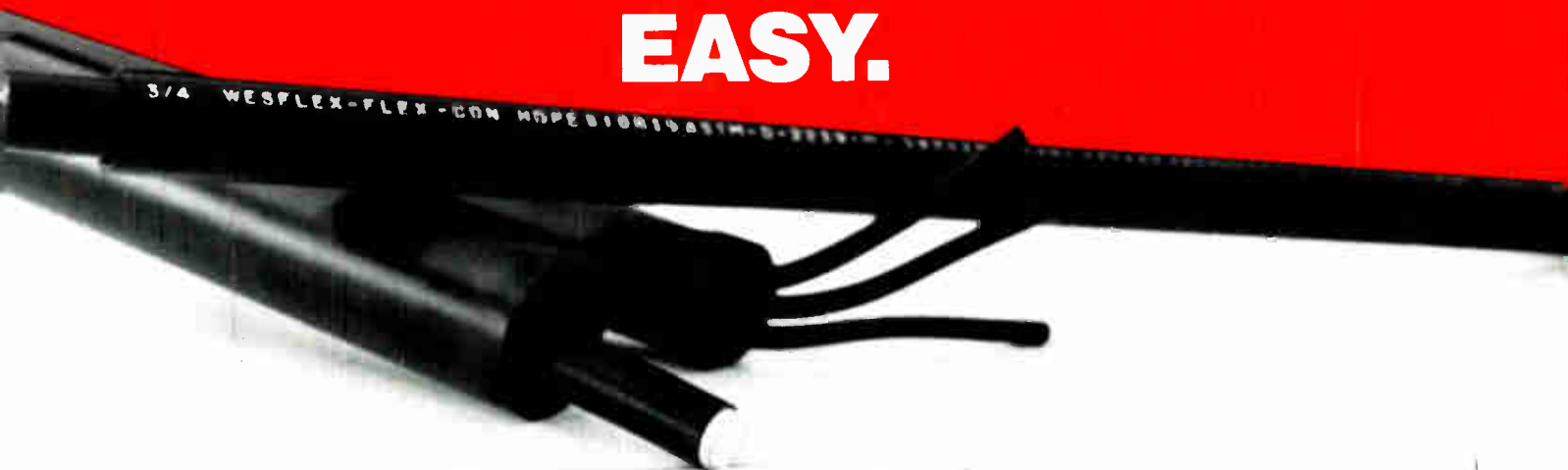

From trunk to distribution to drop cable protection conduit, Wesflex and Horizon Cable/TVC Supply deliver FLEX-CON on time, when and where you want it.

That's why CATV System Operators rely on FLEX-CON conduit for positive buried cable plant protection. Simple to install, direct bury or pull, FLEX-CON is your strongest link

from headend to hub to home.

For quality in affordable polyethylene buried cable protection conduit, there's only one name you need to know. FLEX-CON.

For service and leadership call us. **Wesflex and Horizon Cable/TVC Supply**, your Number One conduit connection!



934-E Calle Negocio  
San Clemente, CA 92672  
Telephone: 714/361-2011  
Facsimile: 714/361-2106



1880 Garden Tract Road  
Richmond, CA 94801  
Telephone: 415/233-6670  
Facsimile: 415/237-7322

pared to other similar industries. "I think this industry has no where to go but up."

At the opposite end of the spectrum sits Tele-Communications Inc. Within TCI, the training burden falls to each of the six divisions, according to Dave Willis, director of engineering for the huge MSO.

TCI Central, which has systems in eight states and 200 towns, relies heavily on the National Cable Televi-

sion Institute and its selection of correspondence courses, says Jim Degenhardt, division engineer. The first two NCTI courses—Installer and Installer Technician—are mandatory, says Degenhardt.

Beyond that, there is little formalized structure to training, he says. Chief techs rely heavily on training that's available from the different vendors and are responsible for filtering that information down to the appropri-

ate people within each system.

Consequently, the climb up the corporate technical ladder is a non-structured one as well, says Degenhardt. In fact, people are having a tougher time moving up that ladder because it's becoming more difficult to find people who are willing to relocate to where the job opening exists. "Relocation and hard work are the keys to moving up," says Degenhardt. If a person isn't willing to move, he's much more likely to remain "stuck" in the same position.

And, there are no detailed job descriptions for the employees, says Degenhardt, who himself is a living example of moving around to move up. He started as an installer and moved across the country before ending up where he is now.

**Leaving it to the system**

At Comcast, training is done at the regional and system levels, says Frank Ragone, vice president of engineering. Comcast encourages movement from within, supports tuition assistance for those people who show the initiative to learn, and encourage NCTI courses by reimbursing those people who pass the courses.

A strong human resources department has detailed job descriptions, so "everyone knows what their responsibilities are," says Ragone. Annual or semi-annual reviews are given to assess employee performance. "It's all very religious here," Ragone adds.

What is less religious is the in-house training. In the ideal world, techs would be subjected to an intensive training session every week. But Ragone concedes that "It just can't fly because that's an expensive thing" when all the costs are added together. And if a system tries to do its training during off-hours to avoid conflicts with productivity, attendance slumps, Ragone says.

Therefore, personal advancement relies more on the "ambition of the individual versus the company taking a leadership role," says Ragone, who agrees that perhaps the best way to move up is to relocate. Personnel shortages vary by system, but in the urban areas, it's easier to find more people, but harder to find skilled people. In rural areas, surprisingly, there are fewer openings because those people are typically more dedicated to their home towns, Ragone says.

MSOs that recognize training shortcomings can look to outside sources for

# SYNDEX "PLUS"

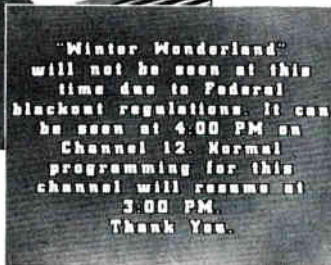

QUANTA's new All-Channel Message System provides the most flexible system available for meeting syndex requirements. Plus, it offers a great selection of other video service options. For example:

- blackout messages — full page or crawl — with a different message on any channel
- substitute program switching — with advisory crawl
- headend or VCR switching
- advance scheduling
- planned interface to syndex databases

- syndex logging
- remote control

And, other video messages can be created to display emergency alert crawls, cross-channel promotions, sports score displays, or any other information desired.

APC workstation handles all programming and text entry — no external character generators needed!

Call Quanta today for more information on ACM — the SYNDEX "Plus" answer.



## QUANTA

Quanta Corporation  
2440 South Progress Drive  
Salt Lake City, Utah 84119 • (801) 974-0992

Dynatech Broadcast Group  
Reader Service Number 23

## TECHNICAL TRAINING

custom-designed training regimens. Jones Intercable, when it decided to implement its program, went to Performance Plus and the result was the QIP program. "It's not too tough to get technical training for installers but there aren't many courses for supervisory and time management skills" targeted to the CATV industry, says Dana Eggert, president of Performance Plus.

### Computer based programs

One way to increase training efficiency is to make the knowledge readily available to anyone at any time. Eggert is actively working with several vendors to develop computer-based educational programs to extend the time and effectiveness of training. This way, vendor-specific training can be extended well beyond the typical few days the manufacturer can spend with each system. Eggert's ultimate goal is to build a software library from all vendors to allow systems to spend more time training their employees on time management, etc.

The problem with programs like those that Performance Plus offers is that MSOs wonder why they can't offer the same training themselves, says Eggert. But those same MSOs realize later that to duplicate the same program would devour so much time, that it's ultimately less expensive and more efficient to go to an outside source.

That's important, because many operators give plenty of lip service to training efforts, but don't want to spend much money on it. Typically, in CATV, training expenditures account for less than one percent of personnel budgets and is one of the first areas cut when budget trimming takes place.

### Renewed interest

However, Eggert says she has witnessed a renewed interest in technical training, especially at the installer level. She attributes it to increased competition and a new commitment to customer service. However, she says, until salaries are increased for lower-level personnel, those efforts may not make a significant difference in the way things are done today.

An average installer works in the industry for about three years, says Eggert, compared to 8 to 10 years in the telephone industry. Why? The pay schedule in CATV is much different and the tenure system works differently, too, Eggert says.

"Training costs money, but there is a long-term return," adds Eggert. "(Operators) want a short-term payoff, though. They say it should lead to an immediate service call reduction. So now, training is being geared toward a bottom-line return so they're now more willing to invest in training."

Technical personnel should take advantage of the opportunities that exist and be willing to relocate to get good jobs, says Eggert. "If you have a lot of

initiative, you could move up, but not always. I think hard work pays off. The more ambitious you are...the more you'll move up."

Eggert predicts that as the technical training shortcomings become more of an issue with MSOs, more in-house certification programs will be developed. "It's not a new idea, but it's not been used (extensively) in CATV," Eggert says. But she expects that "setting minimum requirements will

# \$25,000\*

## FACTORY DIRECT PRICING DELIVERS!

Telsta's "Sweet Deal" Package can put a new 1989 A-28 van-mounted Telsta on the road for you with no hassle or headaches and at the lowest factory direct prices.

You'll get the most wanted lift in the CATV industry—fully equipped and ready-to-go.

You'll get fast delivery because we have chassis in stock at five locations across the country.

You'll get the strongest warranty in the industry backed by the strength of Telsta's nationwide network of parts centers and fleet of mobile service technicians.

And you'll get your Telsta direct from the factory with no third-party markup, no dealers, no aggravation. Pick up the phone and call our toll free direct sales line now. Then relax because it's that easy.

**CALL TOLL-FREE: 1-800-521-5351**



Utility version also available. Call for your special price.

\*Prices slightly higher in California. Prices good for 1989 chassis only. All prices FOB Telsta plant excluding taxes and registration.



# TELSTA®

## A LIFT ABOVE THE REST

General Cable Company

P.O. Box 666, 5600 West 88th Ave.

Westminster, Colorado 80030

Phone: 303/427-3700

Facilities in Hayward, CA, Frederick, MD, Lithonia, GA, Muncie, IN

A Unit of Penn Central Industries

Reader Service Number 24

## TECHNICAL TRAINING

be the trend very soon" among the bigger MSOs because they can no longer afford to have "40 percent of their service calls repeated" because the problem wasn't fixed the first time out.

Smart technicians who recognize that the future may focus more on technical prowess would find it advantageous to get started now. Pay more attention to the technical trade journals, actively attend local SCTE chapter meetings and at least explore what the NCTI has to offer.

### Correspondence courses

NCTI, also based in Denver, presently offers five correspondence courses: Installer, Installer Technician, Service Technician, System Technician and Advanced Technician. (By the time this story is published, a new 500-page, 22-lesson fiber optics course will be available through NCTI and future plans include a course on CATV for non-technical personnel.) Each course consists of numerous lessons that build upon the previous ones and students can learn at their own pace. But NCTI doesn't attempt to take the place of on-the-job training, rather it is in-

tended to augment it, says Tom Brooksher, marketing director.

"Our courses are designed to fill in the gaps and spend more time filling in the 'whys' instead of the 'hows,'" he adds. "At the installer level, you can pretty much get away with training people on how to do things, but not why they're doing it. But when you get to the higher-level techs, they need more cable and electronics information."

Also, the courses are aimed at people who look at CATV as a career, not just a job. "We're not here to duplicate or usurp the MSOs' efforts," Brooksher says. "MSOs and systems start the training process, correspondence (training) is more long-term."

"In many ways, national training courses have a strong psychological value" because they give graduates confidence and show that they do indeed know what they're doing, Brooksher adds.

### New SCTE program

And, of course, another valuable national resource is the SCTE, which offers the Broadband Communications Technician/Engineer and Installer cer-

tification programs. The well-known BCT/E program was launched in 1985 and consists of seven categories that must be completed before full certification is granted. The Installer program, launched just four months ago, was designed to "establish minimum generic requirements that should be observed by every installer and installer/technician in the industry," according to Ralph Haimowitz, SCTE director of chapter development and training.

Installers applying for certification will be charged a \$20 registration fee for a year's membership in the SCTE and covers the cost of the installer manual and initial exam fees. Annual dues will be \$20. The training program will consist of proper drop cable preparation and fitting installation, signal level meter reading, safe ladder use and safe pole climbing techniques, says Haimowitz. Certification will be granted for three years.

So, where the future will take the CATV industry remains in doubt. But if technicians are savvy enough to recognize the wave of the future, they'll take advantage of the renewed push for training and be ready no matter which way the wind blows. ■

—Roger Brown

# Introducing

## The 1989 Training Resource Directory

### The first complete guide to training programs for the communications industries!

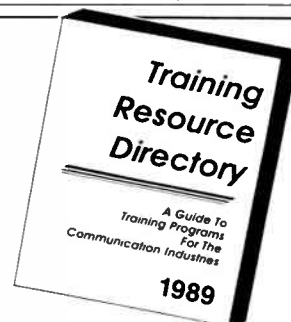

The *Training Resource Directory* gives you:

- The information you need to compare and decide.
- Instant access to more than 600 training programs.
- Two indexes to help you quickly locate programs by the subject/title and vendor.
- The opportunity to save 20% on the directory during this pre-publication offer!

**Order the 1989  
Training Resource Directory  
now for only \$44.95  
1 (800) 333-4965**

**Yes,** I'd like to order \_\_\_\_\_ copies of the *1989 Training Resource Directory* for only \$44.95 each.

- Payment enclosed. (Make checks payable to Performance Plus)  
 Bill me. (We accept Visa and MasterCard).

(Please Print)

Name \_\_\_\_\_ CT 6/89

Company \_\_\_\_\_

Address \_\_\_\_\_

City \_\_\_\_\_ State \_\_\_\_\_ ZIP \_\_\_\_\_

Phone ( ) \_\_\_\_\_ Your DIRECTORY will be delivered in December, 1988.

No risk guarantee: I understand that if I am not 100% satisfied with the 1989 TRAINING RESOURCE DIRECTORY, I may return it to you in good condition within 15 days of receipt and receive a full refund.

Send to: **PERFORMANCE PLUS.**

1050 Posse Road  
Castle Rock, CO 80104

Reader Service Number 25

# Perhaps our most important contribution to CATV powering is restoring meaning to the word reliability.

In the past fifteen years we've made some very significant contributions to the CATV industry. We've developed the most efficient standby power concepts. We've developed the powering technology that delivers the cable signal with unprecedented reliability. In fact, every major standby power innovation has come from Alpha, including complete status monitoring, automatic performance monitoring, uninterrupted power output, and more. But what makes us proudest is to hear people in the industry say we've brought respectability to the standby power business.

Standby power systems were introduced to make CATV signal delivery more reliable.

Ironically, many of the standby systems were notoriously unreliable. They gave the entire industry a black eye.

We've worked very hard to design and build products that keep working under the

most demanding environmental conditions. The fact that we're continuing to grow at an increasing pace while others have faded or disappeared shows that our concern for quality is right. And when our customers tell us we've restored confidence in standby power systems, that's the payoff.

Alpha Technologies. We're here to back you up.



See us at the Atlantic City Show, Booth #510.



3767 Alpha Way, Bellingham, WA 98226-8302  
TELEPHONE: 206-647-2360 FAX: 206-677-4936

5700 Sedley St., Burnaby, B.C. V5J 5E5  
TELEPHONE: 604-430-1476 FAX: 604-430-8908

Reader Service Number 26

# Multichannel video transmission in fiber optics

The use of multichannel fiber optic analog FM transmission meeting RS-250-B medium haul performance is well-established and widespread in broadband systems. Using current FM Frequency Division Multiplexed (FM-FDM) transmission equipment and techniques, combined with unique system architecture, it is now possible to transmit multiple NTSC video and audio signals over extensive distances while meeting RS-250-B short-

haul transmission requirements.

Optimization of individual video FM channel performance allows transmission of up to eight full video channels with RS-250-B short-haul specifications over one single mode fiber path. Aural transmission requirements are met by grouping aural subcarriers in a dedicated FM transmission channel of their own over the same fiber, again meeting all short-haul specifications. Typically, this system architecture can deliver up to eight audio subcarriers per FM channel.

Depending on fiber and optical wavelength selected, the system can operate over distances up to 36.5 km without an optical repeater.

## Using fiber optics

The use of fiber optic transmission in broadcast applications is not new. Both analog and digital transmission techniques are routinely employed by broadcasters and transmission service providers to meet signal routing, remote broadcast, studio-to-transmitter links and other point-to-point requirements. However, much of today's analog system architecture is based on the use of multimode fiber technology, restricting the user to only one or two video channels per fiber. Use of digital video transmission over single mode fiber increases the number of signals but requires the use of expensive A-D

*By Dennis Donnelly, Manager of Systems Engineering for Catel Telecommunications, Inc.*

*Originally presented at 1989 NAB Engineering Conference*

Video Block Diagram

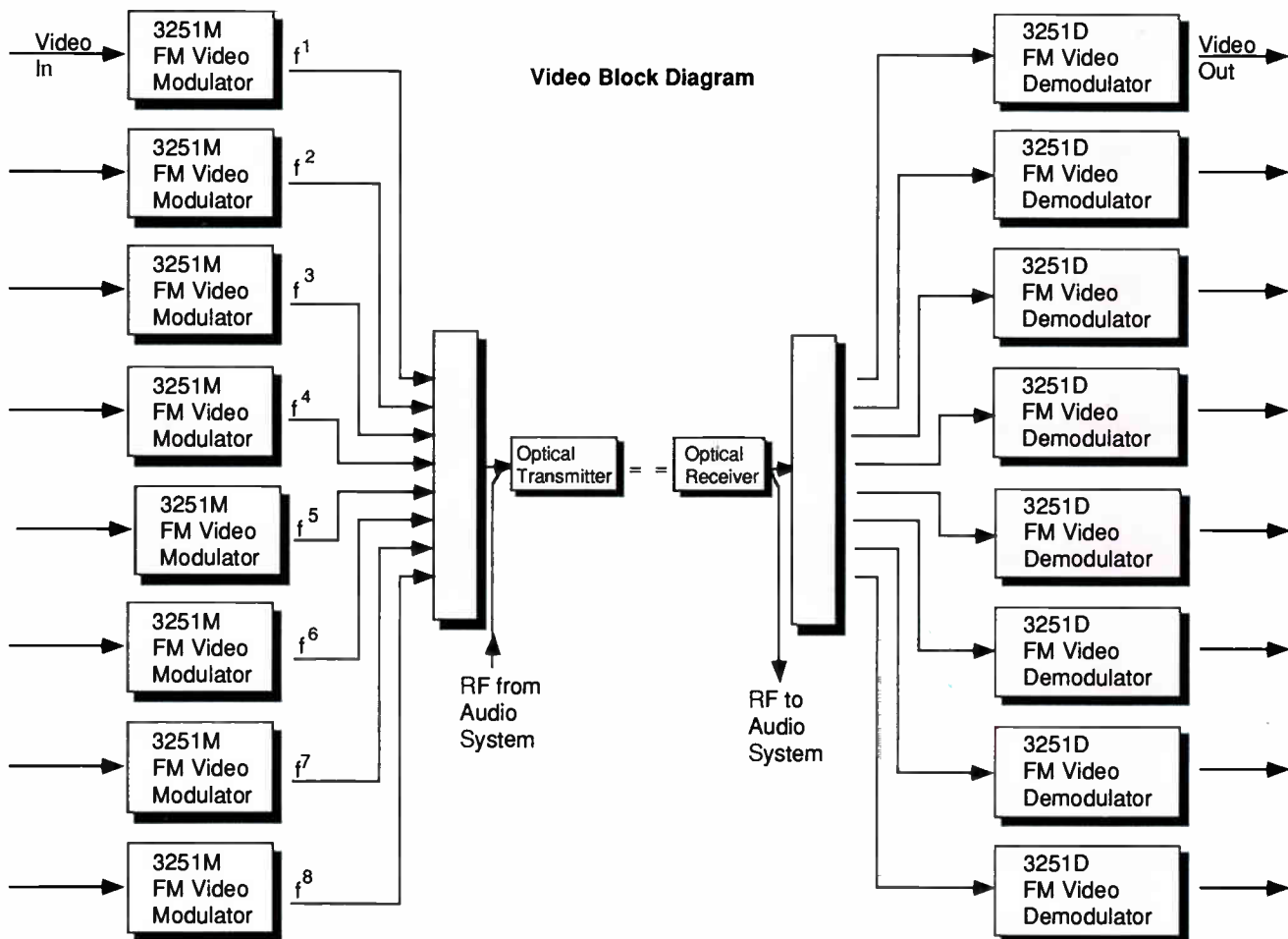

Figure 1

# COMM/SCOPE. THE CHOICE IN CABLE.

With our Optical Reach Fiber Optic Cable and our full line of coaxial cable products, Comm/Scope can offer you something few cable suppliers can. A choice. Because strategy and planning in CATV today requires consideration of both types of cable. Fiber and coax. And how they fit in your future plans.

And, because you also know that the best quality cable and service you can get comes from Comm/Scope, you don't have to wrestle with your other important decision. Who to go to for your cable. The Choice is Comm/Scope. THE Cable in Cable TV.

To find out more about Optical Reach or any of our other fine cable products, contact your nearest Comm/Scope representative or call Comm/Scope, Inc. 800/982-1708 (800/222-6808 in NC).

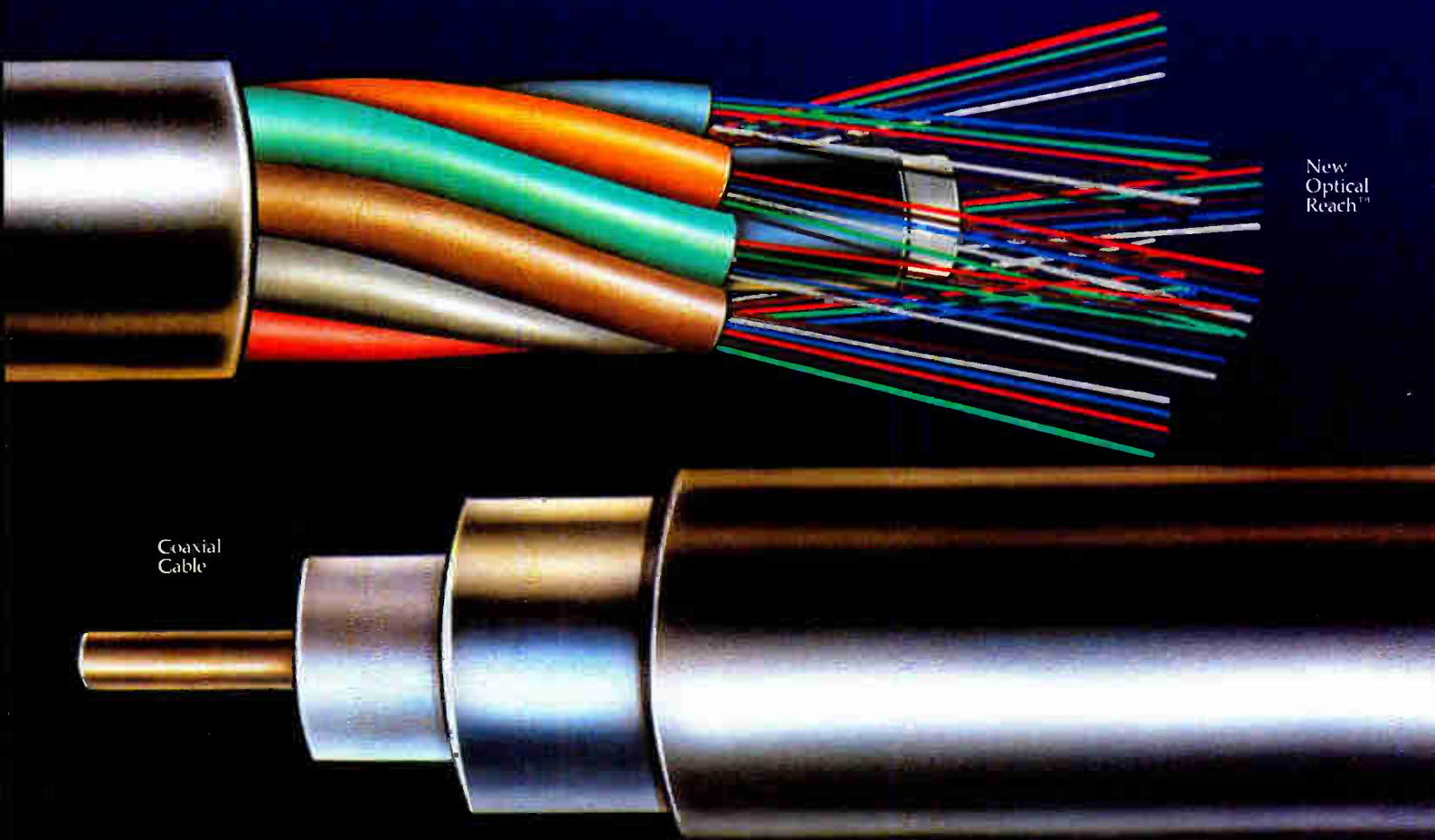

**Comm/Scope, Inc.**  
THE Cable in Cable TV.

Comm/Scope, Inc., P.O. Box 1729, Hickory, NC 28602.  
Phone 800/982-1708 (800/222-6808 in NC). Fax: 704/328-3400. Telex: 802-166.

Reader Service Number 27

## FIBER OPTICS

and D-A converters.

Increasingly, the broadcast community is seeing a need for a fiber optic system which combines the ability to transmit multiple signals meeting RS-250-B short-haul performance with the flexibility to carry these signals long distances and/or provide point-to-multipoint service connections, and do so at a reasonable cost.

The use of FM frequency division multiplexed transmission to transport up to eight video and 16 or more audio signals per single mode fiber is a solution to these needs. Wide deviation FM equipment already in use is virtually transparent to the signals and offers transmission of video, multiple audio and data over a single fiber. Adaptation of this technology produces reliable performance at RS-250-B short-haul specifications. The FM-FDM system is flexible in architecture design, providing point-to-point or point-to-multipoint service. Within the limitations of the available system link budget, which is 13 dB, the FM-FDM system can be split optically to serve a number of points from a single transmission location. The system can even function as a bi-directional system, with signals flowing both directions

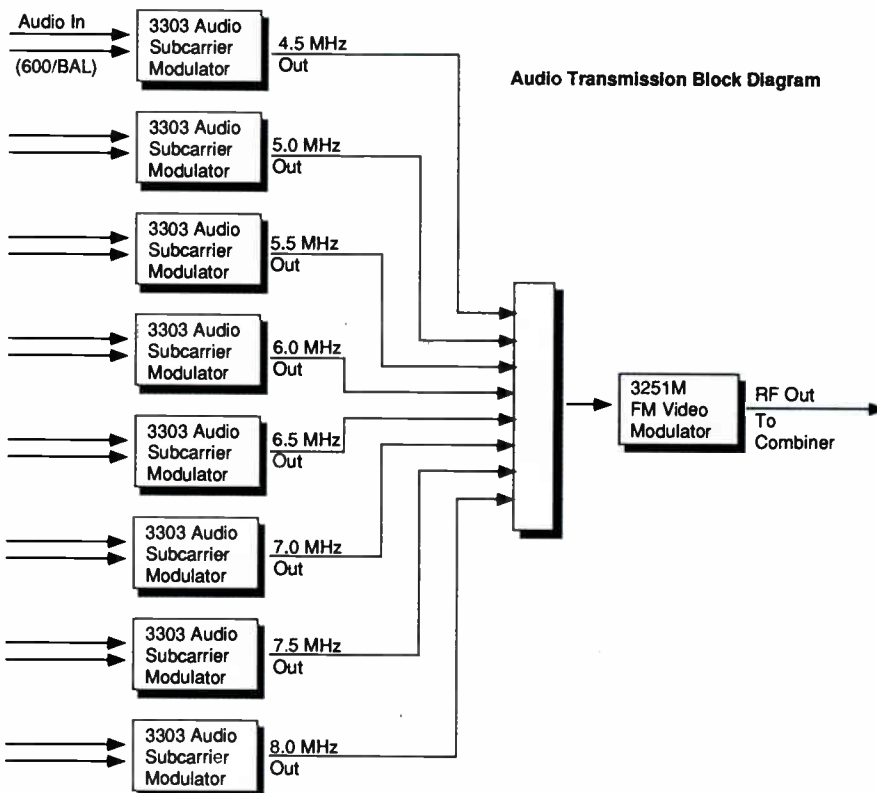

Figure 2

## Wideband Noise

On Lower Off-Air Channel?



Before



After



2903  
Interference  
Eliminator

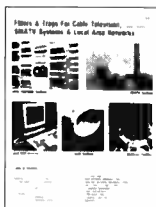

C/87

*Hundreds in use by CATV systems. Full details in free catalog C/87 - the industry's most complete selection of filters and traps for CATV, Private Cable, Institutional TV and Local Area Networks.*

Microwave Filter Co., Inc. 6743 Kinne St., E. Syracuse NY 13057  
Toll Free: 1-800-448-1666 • Collect: 315-437-3953 • Telex: 249-613 • Fax: 315-463-1467

Reader Service Number 28

Quality and Performance done  
the Rite Way



offers you more:



- Fiber optic
- Underground
- Aerial
- Cable
- Construction
- Strand Mapping
- Splicing



**Rite Cable Construction  
Provides All Your  
Engineering & Construction  
needs, including Fiber Optics  
704/874-4202**

Reader Service Number 29



# AM OVER FIBER, FM/VSB-AM HYBRIDS, FM FIBER SUPER TRUNKS

## WHICH SYSTEM IS RIGHT FOR YOU?

Planning to rebuild or expand? There is no better time to explore the advantages of fiber optic transmission. A fiber system can improve your delivered signal quality, and improve overall system reliability.

No company offers more CATV fiber solutions than TFC. We know that no single system or technology is best for all applications. Our first CATV fiber system was placed in service in 1978. Today we offer systems with multiple fiber technologies,

each with its own advantage for CATV applications.

**Call us to discuss your specific requirements.** Let us put our eleven years of CATV fiber experience to work for you. We'll answer your questions on all phases of a fiber optic system, for which technology is best to planning the actual installation.

**Call us at 203-265-8510**



**TFC**  
an  
L.P.C. company

**TIMES FIBER COMMUNICATIONS, INC.**

358 Hall Avenue, Wallingford, Connecticut 06492

Reader Service Number 30

Audio Receive Block Diagram

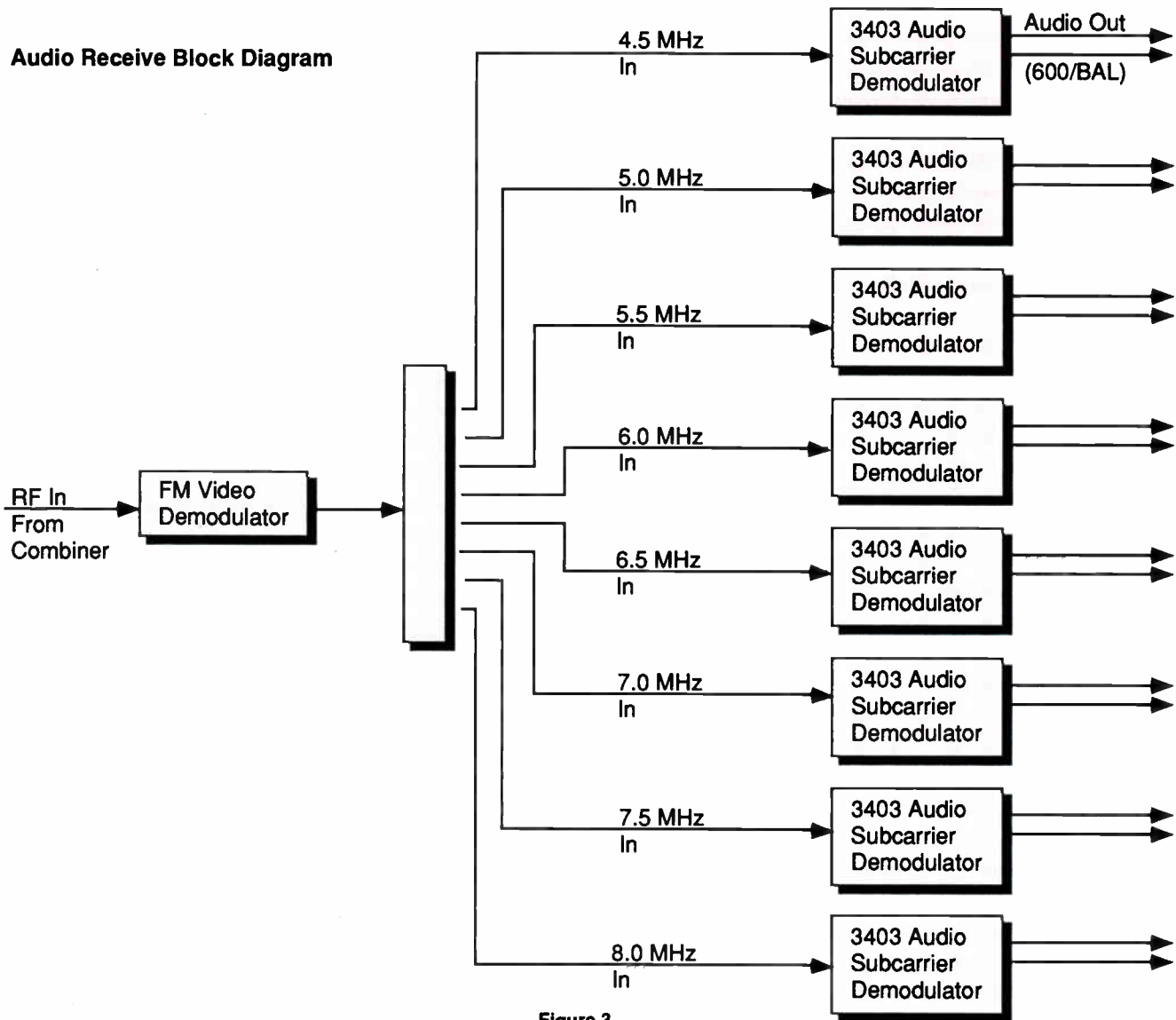

Figure 3

simultaneously over the same fiber and at the same wavelength. This can eliminate the need for Wavelength Division Multiplexing (WDM) in most applications.

**System architecture**

FM-FDM multichannel fiber optic transmission is already being used in many broadband applications. Most of these systems operate with up to 16 video and audio channels per single mode fiber while meeting RS-250-B medium-haul specifications. Generally, in these applications, a single audio channel is carried as a subcarrier within the video channel. This method presents certain limitations to specifications due to the necessity of providing subcarrier filters to remove the

In order to meet the required signal-to-noise performance of 67 dB, it is necessary to limit the number of video channels per fiber.

audio subcarrier from the video signal. These limitations, which do not compromise performance at RS-250-B medium-haul specifications, nonetheless inhibit the video signal performance sufficiently to require a different architecture to meet RS-250-B short-haul specifications.

Additionally, in order to meet the required signal-to-noise performance of 67 dB, it is necessary to limit the number of video channels per fiber.

To meet these requirements for RS-250-B short-haul, a different system architecture has been developed. The video and audio signals are all carried on the same fiber, but handled in a different manner.

In the video signal system block diagram shown (Figure 1), the video FM modulator accepts the video signal,

# US

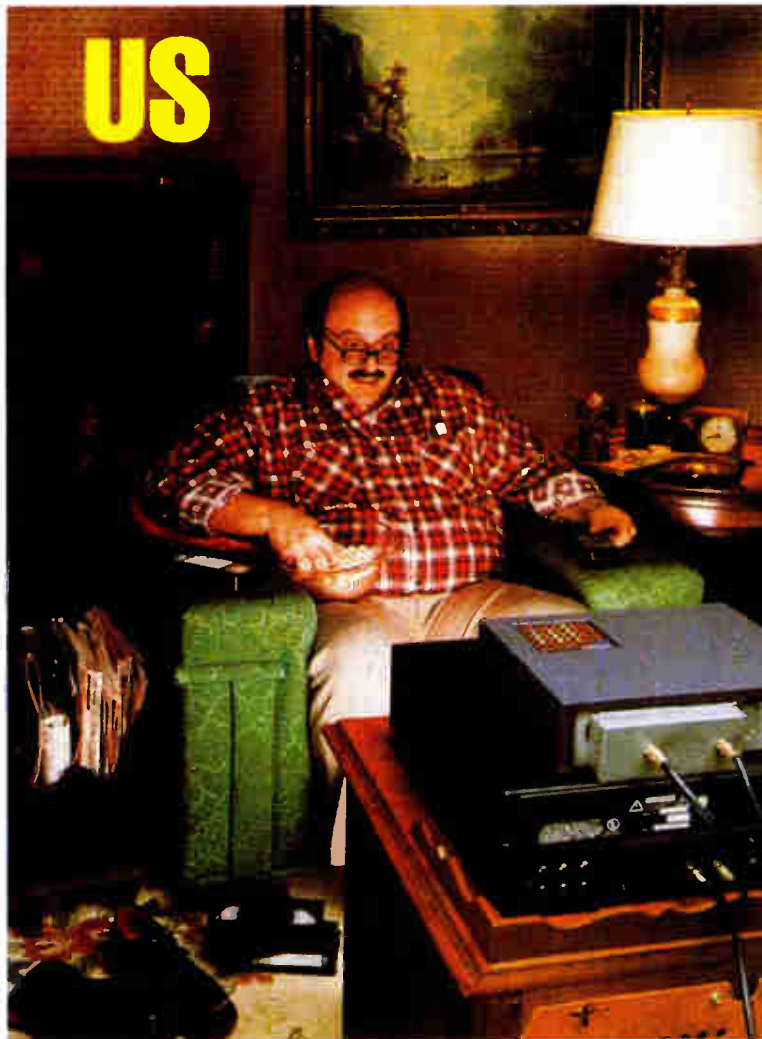

# THEM

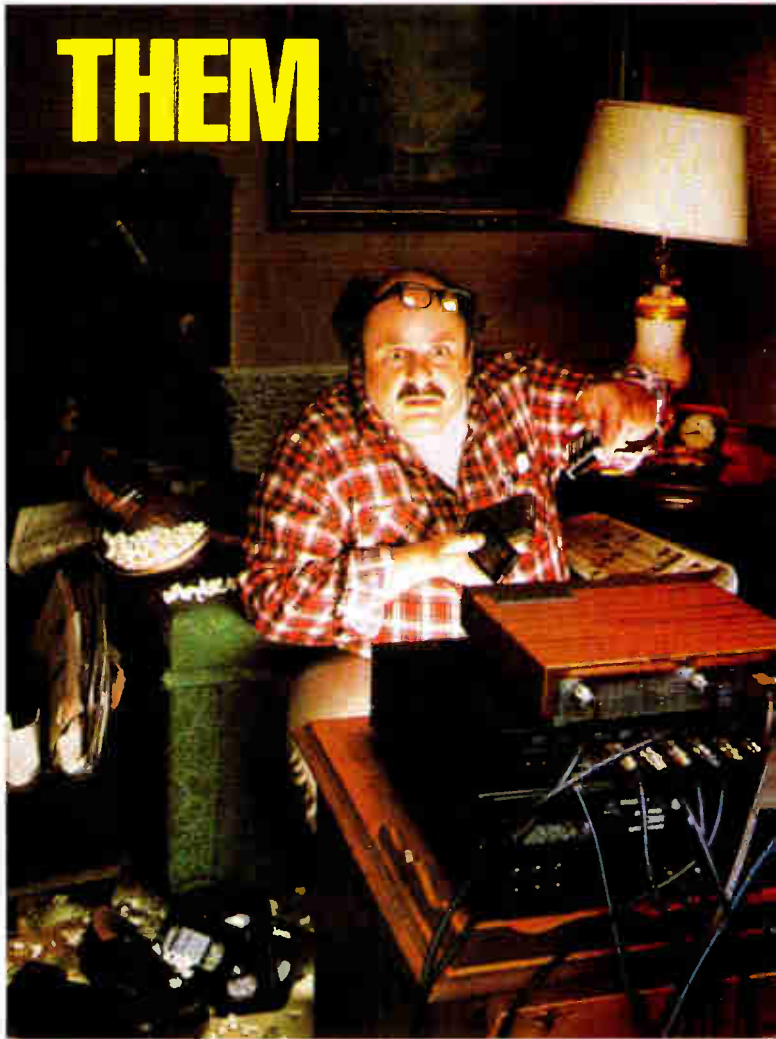

## Consumer Satisfaction or Dissatisfaction?

Our answer is satisfaction.

With Pioneer's BA-6000 addressable converter, never again will your subscribers experience the frustration and inconvenience associated with their TV, VCR and cable converter. The advanced BA-6000 finally removes VCR incompatibility and multiple remotes from the picture.

Four VCR program timers and volume control are standard. Pioneer's unique VCR Filter™ allows subscribers to record a pay program while watching a basic channel, or vice versa. A built-in IPPV module lets subscribers conveniently order events at the touch of a button. The BA-6000 even offers an easy-to-read display and a remote control with bigger keys and improved labeling.

The BA-6000 with volume control, packaged with the VCR Filter™, integrated IPPV and a SmartRemote™ offers the most comprehensive solution to consumer interface problems.

To get the picture on the Pioneer BA-6000 addressable converter, call (800) 421-6450 and stop testing your subscribers' patience.

**Pioneer BA-6000. The Choice is Yours.**



Reader Service Number 31

**PIONEER®**

PIONEER COMMUNICATIONS OF AMERICA, INC.

600 East Crescent Ave. • Upper Saddle River, NJ 07458  
(201) 327-6400 • Outside New Jersey (800) 421-6450

# Performance Building Blocks



# ISS STACKS UP

Our exceptional lineup of frequency agile performers is engineered to work together to give you outstanding performance and the quality and innovative feature design you need now. In fact, you may be surprised to find that the performance attained with our agile equipment is not only comparable to conventional fixed channel equipment, but often superior. And it's all backed by the ISS full three-year parts and labor warranty.

## Series III Agile Modulator

The introduction of the ISS Series III Agile Modulator makes it no longer necessary to use a fixed channel modulator to obtain the performance you require. That's because our in-band and out-of-band carrier-to-noise ratios and phase noise measurements are better than what you can measure with most spectrum analyzers!

- **Now more than 60-channel operation without the need for external bandpass filters!**
- 80dB out-of-band carrier-to-noise ratio
- Greater than 74dB in-band carrier-to-noise ratio
- Phase noise measurement surpasses the 1988 NCTA Pidgeon and Pike recommended specification
- Pre-emphasis on/off switch allows for BTSC for normal audio inputs
- Agile from 2 thru WW with optional agility from Channel T7 thru 550 MHz
- Offsets plus or minus selectable
- Audio subcarrier phase locked to a crystal ensures FCC-required intercarrier stability
- RS-232 remote control available

## GL-5020 Satellite Receiver

Our U.S. made GL-5020 Satellite Receiver comes equipped with a plug-in VideoCipher® II Descrambler module installed up front - where it belongs. This gives you fast, easy access to the address number through a translucent front panel window. And the back of the GL-5020 receiver features the cleanest rear panel design in the industry, making it simple to connect and easy to read.

- Front panel VideoCipher® II Descrambler
- Easy-to-read address number
- C-, KU-, L-band tuning by channel or frequency
- Generous ventilation ensures cool operation
- Meets RS-250B standards
- Remote control via built-in RS-232 port

## GL-1000A Series Demodulator

The backbone of the ISS MSII Processing System, the GL-1000A Demodulator provides the cleanest, clearest video performance available for local off-air channels when combined with the Series III Modulator. Its simplicity of set-up, ease of operation and agility, coupled with a wide variety of options make it truly flexible.

### Features

- Nonvolatile user-programmable memory
- Broadcast version available
- Tunes all VHF, UHF, and cable channels (STD or HRC)

### Options

- -01 4.5 MHz Audio on Video
- -02 T Channel (Subchannels)
- -03 Separate Audio/Video IF

For more information, please call or write:  
**ISS Engineering, Inc.**  
1047 Elwell Court, Palo Alto, CA 94303

ISS West Toll-free (800) 227-6288  
(415) 967-0833 FAX (415) 967-0772

ISS East Toll-free (800) 351-4477  
(205) 853-6919 FAX (205) 854-4581

**ISS**  
**ENGINEERING, INC.**

*We Simply Bring Communications Down to Earth.*

Reader Service Number 32

VideoCipher® is a registered trademark of General Instrument Corporation.

# FIBER OPTICS

**Multichannel Fiber Optic System**  
RS-250B Short Haul Performance  
Fiber Frequency Plan

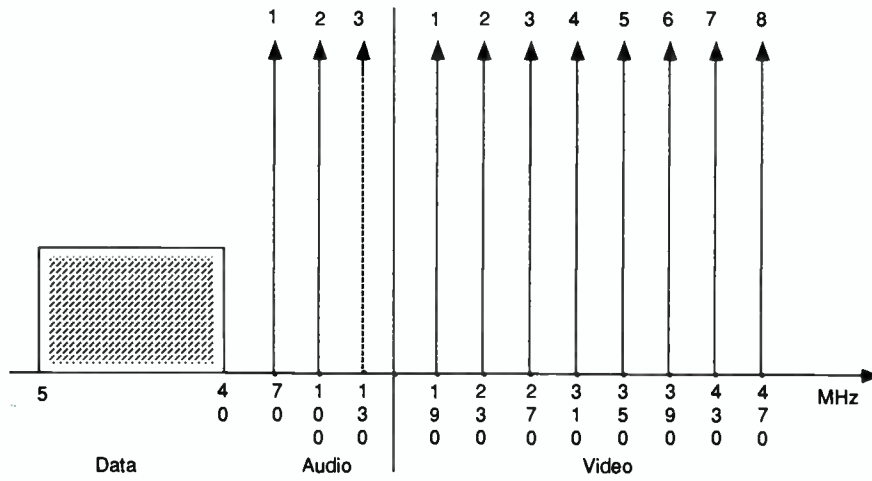

**Figure 4**

eight total, is modulated by its own FM unit to a different RF frequency. The RF output of each of the modulators is terminated in a passive combining network. Once combined, the RF signal is presented to the input to the optical transmitter. Within the transmitter, the signal is applied to a laser modulator. The laser is intensity modulated and the light output is coupled to a single mode fiber for transmission. The transmitter operates at a wavelength of 1310 nm.

At the receive location, the light is coupled to the optical receiver, where the photoconductor detects and converts the light back to the combined RF signal. This signal is applied to a passive splitting network which presents the signal to the input to each video demodulator. A frequency agile input converter responds only to its FM frequency and converts it to a 70 MHz IF signal. The IF signal is demodulated by a wide deviation demodulator and then processed, de-emphasized and output in the original NTSC video format.

processes and pre-emphasizes it, modulates it to a wideband 70 MHz IF signal and then converts it to an RF frequency using a frequency agile output con-

verter. The deviation of the FM carrier is 6 MHz sync tip to peak white and the FM channel bandwidth is 40 MHz. Each video signal channel, up to

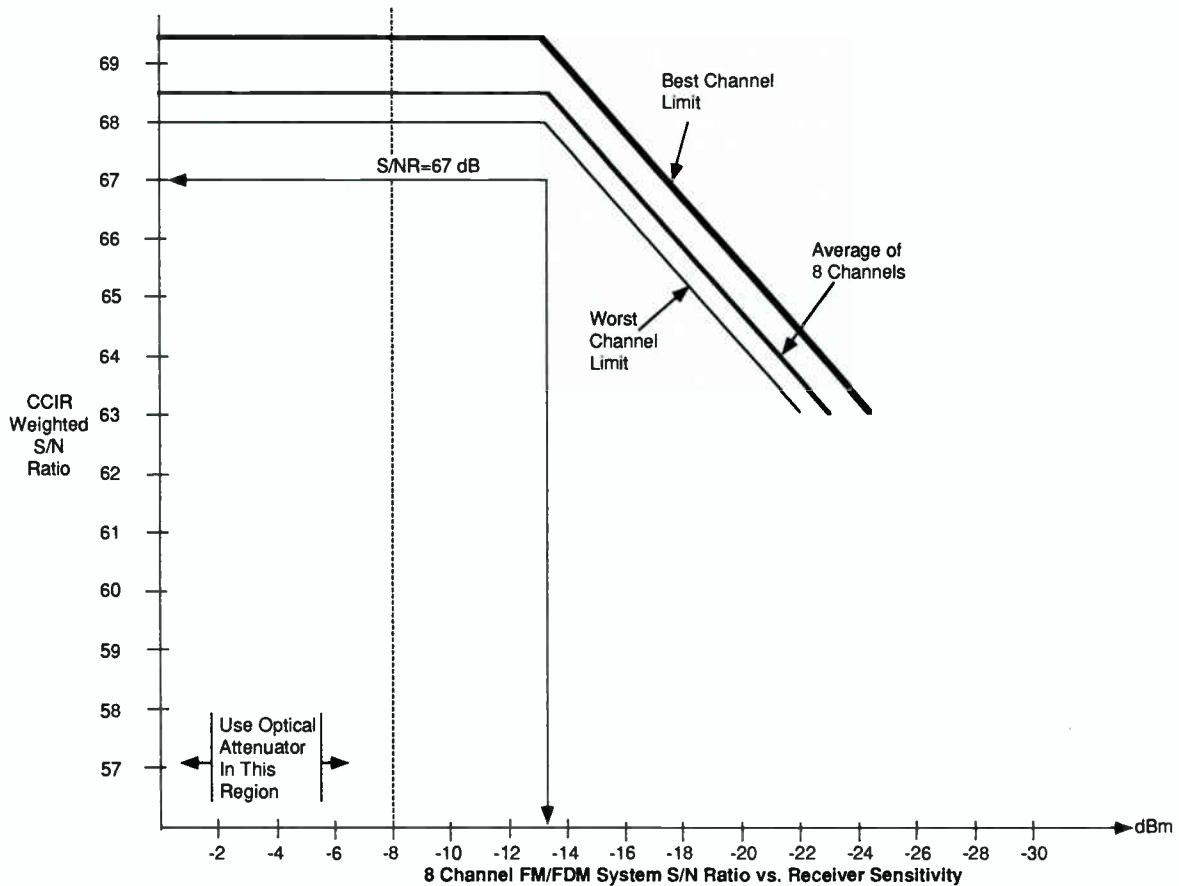

**Figure 5**

# One Small Step For Mankind...



## One Giant Leap For Technology.

### NEW **PATHMAKER PLUS+**

Texscan brings tomorrow's technology into today with an innovative group of Opto/RF distribution products that offer:

- A unique "space platform" for increased growth capacity.
- **True 1 gigahertz capabilities in bandwidth and return loss.** Both specifications critical to the carriage of future HDTV formats.
- Fully integrated Opto/RF design for flexibility in AM Fiber Optic Technology for "stand alone nodes" or "hybrid" Opto/RF system architectures.
- Full Plug Compatibility with **Laser Link™** AM Fiber Optic systems — the industry's most widely-used, field-proven AM Fiber Optic System.

#### Pathmaker Plus+ features:

- Modular upgradeability to AM Fiber in single, dual, or multiple Fiber architectures.
- Return Laser capabilities for both DATA and Data/Video applications.
- All available RF technologies in popular bandwidths. Feedforward, Power-Addition, and Push-Pull. Plus a unique bridger architecture for unsurpassed performance and efficiency. High-Gain Trunk and Bridger Modules available for easy upgrades.
- Field proven Vital Signs™ status monitoring for both RF and Fiber Optic.
- Superior thermal management characteristics for long-term reliability.

- New ultra-efficient switching regulator D.C. supply with redundancy options.
- New PAL-5 high-efficiency line extenders in 32 and 40dB gain versions featuring plug compatibility with popular models which allow for more cost effective completion of rebuilds and upgrades.

Contact your local Texscan representative or call us at 1-800-351-2345 for more information. Texscan will put tomorrow's technology to work for you today!

DISCOVER THE POWER OF TEXSCAN.

# Texscan

PATHMAKERS IN TECHNOLOGY

**Mileage, Losses and Margins—1310 nm**

Dist (MI)	Dist (km)	Fiber Loss/Km	Total Fiber loss	Splice Loss/2 Km	Total Splice Loss	Total Path Loss	Link Budget	Link Margin
12.40	19.96	0.5 dB	9.98	0.1 dB	1.00	10.98	13.00	2.02
15.15	24.38	0.4 dB	9.75	0.1 dB	1.22	10.97	13.00	2.03
17.00	27.36	0.35 dB	9.58	0.1 dB	1.37	10.94	13.00	2.06

**Mileage, Losses and Margins—1550 nm**

22.75	36.61	0.25 dB	9.15	0.1 dB	1.83	10.98	13.00	2.02
-------	-------	---------	------	--------	------	-------	-------	------

Figure 6

To provide full audio capability, nominally with two channels of audio per video signal, each audio signal is first modulated by an FM modulator onto an RF subcarrier frequency, as shown in the block diagram (Figure 2). All of the subcarrier frequencies are also terminated in a passive combiner whose RF output is the input to a wide deviation FM video modulator. The combined subcarrier signal is FM modulated to an RF frequency which is added to the video modulator frequencies at the input to the fiber optic transmitter. Each group of up to eight audio signals is treated the same, using the same subcarrier frequencies. Utilizing this system, up to 24 audio signals can be transmitted along with

the eight video signals. This will meet the need for dual audio feeds for stereo broadcasting and allow other audio signals to be carried as well.

At the receive location (Figure 3), the RF frequency with the subcarriers on it is demodulated by a companion FM video demodulator. The subcarrier frequencies are passively split and demodulated by individual subcarrier demodulators.

Should the need arise, low speed data signals can also be carried on the fiber system. RS-232 data, at rates up to 19.2 kbps, is FM modulated and carried at the lower end of the RF spectrum. This type of data channel occupies a narrow portion of the fiber optic bandwidth, typically 400 kHz or

less and does not interfere with performance of the video or audio system.

RF frequencies are selected to minimize intermodulation distortion in the laser. A typical eight-channel system will have a frequency allocation or channel mapping plan (Figure 4) utilizing most of the spectrum from approximately 70 MHz to 500 MHz. As noted previously, the video channels are 40 MHz wide.

The audio system has somewhat lower deviation than the video system and is spaced every 30 MHz. The 5 MHz to 40 MHz portion of the spectrum is typically reserved for data or other narrow band information.

The final step in this architecture is to assure excellent signal-to-noise performance. In the system just described, the back-to-back performance of the FM system without the optical components will yield video signal-to-noise performance well in excess of 73 dB. However, when the system is applied to the fiber optics network, there is going to be some loss of signal-to-noise quality. There are a number of contributing factors, among them the noise generated in the laser diode and the dark current generated by the photoconductor.

**WANTED!**

We also purchase or trade dead or alive red, white or yellow labeled VC IIs.

**\*VIDEOCIPHER II REPAIRS**

*Fast Turnaround for Out of Warranty Repairs*

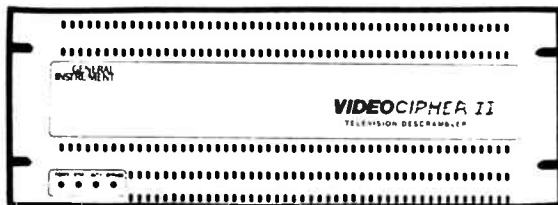

**\* VIDEOCIPHER II DESCRAMBLER REPAIR**

**\*\*Fast Turnaround for Out of Warranty Repairs**



1575 N. 105th E. Ave./ Tulsa, Oklahoma 74116

(918) 836-8348

Reader Service Number 34

\*\*Turnaround for most units 10 days or less. We do not repair units with loss of memory. Call Cindy for more information.

\*VideoCipher® is a Registered Trademark of General Instrument Corporation

**Hardware & Software for \$6,000**

Cable/1 AT Compatible System



**Computer Utilities**

SERVING THE INDUSTRY FOR OVER 10 YEARS WITH OVER 100 INSTALLATIONS

**CABLE/1 Hardware:**

512 RAM, 30MB Hard Disk, Diskette, Monochrome Monitor, Epson EX-1000 fully IBM PC/AT compatible.

**CABLE/1 Software:**

Software alone starts at under \$3,000. Management Information and Accounting System Complete In-House Accounts Receivable and Billing Software Multi-user Capability Optional

Ideal for SMATV, MDS, as well as cost-effective solutions for Independents and MSOs.

System is also available on the PC/XT and IBM SERIES/1 Minicomputer for virtually unlimited growth.

**Find out what others know about our In-House, On-Line Management Information and Accounting System for the IBM Series/1 and PC.**

**Computer Utilities**

P.O. Box 1062, Harrison, Arkansas 72601

(501) 741-1616

HERB LAIR, President



Utilizing the known FM signal-to-noise improvement to overcome these, the system is capable of exceeding the toughest specifications for signal-to-noise. The performance of an eight-channel system is graphed (Figure 5) in terms of signal-to-noise performance vs. the sensitivity of the optical receiver. The stated performance limit is based on a 13 dB loss budget. Allowing for standard manufacturing variation in individual FM units, the system still has margin over the 67 dB signal-to-noise specified by RS-250-B short-haul. As can be seen, the system operates at a signal-to-noise plateau through the

especially signal-to-noise. While the link has a theoretical budget of 24 dB to 26 dB, the system described has been specified based on meeting 67 dB signal-to-noise in regular operation without special maintenance or adjustment procedures.

The obvious question is, "How far will a 13 dB budget allow the system to operate?" The answer to this question lies, not with equipment, but with the choice of fiber for the system. The

accompanying chart (Figure 6) shows the distances which are feasible with fibers which range from standard 0.5 dB/km loss to very low loss 0.35 dB/km fiber at 1310 nm. As can be seen, the distance can vary from 20 km to 27½ km. Some general assumptions regarding the system have been made. These include splice loss of no more than 0.1 dB per splice, with splices occurring at intervals of not less than every 2 km and a chosen minimum link safety

The FM-FDM system architecture is extremely flexible and easily configured or modified to meet exact requirements.

range of the loss budget. The system is specifically designed to take advantage of this. The nominal laser output for this type of performance is in the range of 0 dBm.

The system is conservatively designed and specified and will meet or exceed all RS-250-B short-haul specifications. Typical performance data will be presented later.

The FM-FDM system architecture is extremely flexible and easily configured or modified to meet exact requirements. Once the basic components for one channel of video and audio are in place, additional channels can be added as needed simply by putting more FM equipment into operation. The FM electronics are modular and housed in a universal chassis. This allows the system to be reconfigured easily, requiring only changes in coaxial connections on the rear of the chassis. The modular format also allows the addition or update of individual modules which may be necessary to handle future new requirements, such as HDTV.

**System link budget**

The system link budget is based on overall performance to specification,

# AMERICA!

We've got your cable supplies:

- Cable T.V. Equipment & Accessories
- Telecommunication Products
- LAN Equipment

We work with some of the Best in the Business:

- GILBERT
- JERROLD
- COMM/SCOPE
- TIMES FIBER
- BLONDER TONGUE
- LRC
- CARLON
- BASHLIN
- TYTON
- MULTILINK

## WASHINGTON CABLE SUPPLY, INC.

Extending beyond the nation's Capitol-  
Serving you from coast-to-coast

3182 Bladensburg Rd., NE  
Washington, DC 20018  
FAX #: (202) 832-2449  
(202) 832-7422

Call for Competitive Prices  
or More Information

**1-800-888-0738**

See us at the Atlantic City Show, Booth 800.

Reader Service Number 36

margin of 2 dB.

This is a conservative margin but it is planned for a worst-case scenario. This assures the ability of the system to perform to specifications under adverse conditions. Such a condition might include an emergency splice in the fiber, where the need to re-establish service exceeds the immediacy of properly aligning the splice. This kind of condition can result in a temporary addition of 1 dB or more to the fiber

link loss.

The chart also shows the additional distance gained from operation at 1550 nm with 0.25 dB/km loss fiber. These figures are based on a fiber which has a second window at 1550 with a known loss. Please be forewarned that, although losses at the 1550 window will generally be lower than the 1310 window, manufacturers do not guarantee performance unless fiber is specifically ordered that way.

All of these figures are for a single point-to-point application. As indicated, the system can be optically split to feed several locations at the same time. A typical star architecture is shown (Figure 7), using a single transmission point and feeding two locations which are equidistant from the transmitter. In this case the optical signal is split in a 50/50 ratio with half the power going to each location. A 50/50 optical coupler will introduce a 3 dB loss in the path. Actually, it is somewhat greater than that, since there are splices on either side of the coupler and a small internal loss in the coupler itself. The resulting distances shown in this chart include the additional losses for the

**ARU's tailored to suit**

**Your Needs  
Your People  
Your Budget**

**The Command Center**, by Access Logic Technologies, is *the* comprehensive communications system designed to increase call handling capability while decreasing costs.

**The Command Center** offers the variety and flexibility to improve customer service levels.

**The Command Center** is easy to use and reduces CSR handled calls.

**The Command Center** is less expensive than other ARU's. Every unit is direct from the manufacturer. You pay no "middle men".

These are only a few of the services that can be added or deleted to suit your needs:

- 1** ARU's place pay-per-view orders 24 hours a day.
- AUTOMATED OPERATOR** services customer needs more efficiently with "one number" access.
- VOICE MAIL** sends or receives multiple messages simultaneously.
- SYSTEM SUPPORTS** . . . touch tone, voice recognition, ANI, DID type lines.
- CALL MANAGEMENT** lets you know how many called and why.



**ACCESS LOGIC**  
TECHNOLOGIES

One Tandy Center Plaza  
Ft. Worth, TX 76102-2858

**817/877-5629**

Please call for complete literature package.

Reader Service Number 37

A 50/50 optical coupler will introduce a 3 dB loss in the path.

coupler.

In the case of a typical tree-and-branch architecture, where the distances are not the same, (Figure 8) the coupler ratio is selected to provide a nearly equal optical loss at each receive site. The coupler selected is a standard ratio split, which is readily available from the manufacturer. However, custom splitters can be obtained for an even closer match, if desired.

Generally, the limitation on the number of optical splits is determined by the overall budget vs. the number of locations and distances to each. As long as the total loss does not exceed the system budget, equal performance will be seen at all locations.

Although the subject is specifically related to fiber optics, it should be noted that the multichannel system can function on a short run coaxial broadband network as well.

**System performance**

Each FM-FDM multichannel fiber optic system is assembled and carefully system tested either using fiber or an equivalent optical attenuation equal

## FIBER OPTICS

Link Margins for an Equal Split

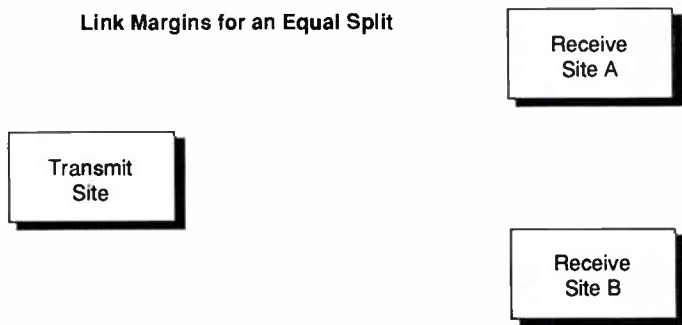

From	To	Mi.	Km.	Fiber Loss	Splice Loss	Total Path Loss	Coupler Loss	Ratio	Total Link Loss	Link Budget	Link Margin
Transmit	Site A	8.5	13.68	6.84	0.68	7.52	3.50	50/50	11.02	13.00	1.98
Transmit	Site B	8.5	13.68	6.84	0.68	7.52	3.50		11.02	13.00	1.98

Figure 7

to the actual fiber loss from the transmit to receive site. Many of the RS-250-B short-haul parameters are basic to the design of the FM modulation sys-

tem and are tested to be compliant even before the final system is tested. To assure the test accuracy of the most critical parameters of the system, final

system test is conducted using an Anritsu Model MG 311B video signal generator and its companion unit, the Model 349D video signal analyzer. The

## BSE-Pro™ A NEW STANDARD IN CATV DESIGN!

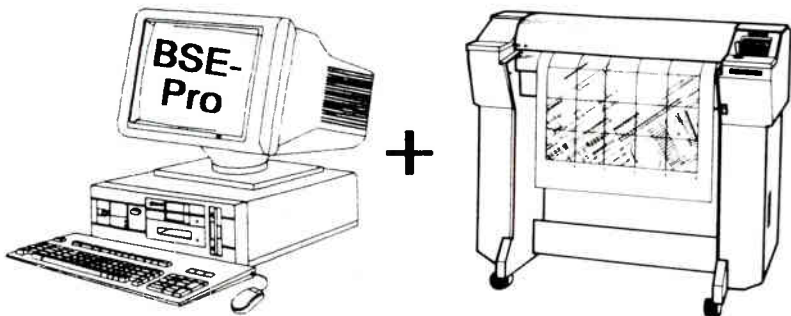

A VERY AFFORDABLE AND FULLY INTEGRATED CATV & LAN DESIGN CAD SOFTWARE PACKAGE FOR THOUSANDS OF DOLLARS LESS!

### BSE-Pro (REL 1.0) WITH FEATURES FOUND NOWHERE ELSE!

- Real time AC Powering and Distortion calculations *without* leaving the design!
- Databases design. Report generator: BOM with costing and Distribution reports!
- Pull-down menus with customized dialog pop-up boxes with editing features!
- Design size limited by free hard disk space. Infinite number of amplifiers, taps, etc!
- Extra capacity component database can be mixed with multiple manufactures.
- Designs to 2,000 MHz. User defined splits or dual cable. Supports 1.5 dB taps.
- BSE-II™ for even more affordable design software with features similar to BSE-Pro!

### Plot Your BSE-Pro Designs with AutoCAD®



Optional add-on **BSE-Pro CAD™** transforms your design into SCTE drawing symbols using AutoCAD Rel.10. Plot or graphically display your design.

### OPERATIONAL BSE-Pro TRIAL DISK AVAILABLE!

Order a functional trial copy of BSE-Pro that allows you to do actual design for only \$50. Not a DEMO disk! Your \$50 will be credited towards full purchase price of BSE-Pro or BSE-II should you buy within one year. Send check, or call/fax using your American Express credit card, to our address. No POs or C.O.D.s please. Specify 3.5" or 5.25" disk.

"TEST FLY BSE-Pro BEFORE YOU BUY!"



Reader Service Number 38

512-892-2085

3310 Western Dr.  
Austin, TX 78745  
Fax 512-892-0959

## FIBER OPTICS

### Link Margins for an Equal Split

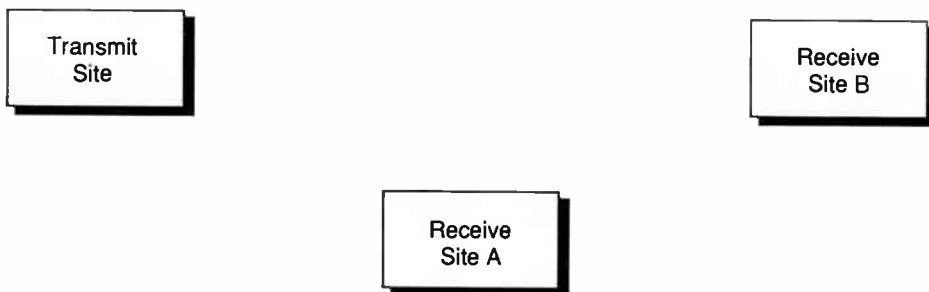

From	To	Mi.	Km.	Fiber Loss	Splice Loss	Total Path Loss	Coupler Loss	Ratio	Total Link Loss	Link Budget	Link Margin
Transmit	Site A	6.0	9.66	4.83	0.48	5.31	5.10	35/65	10.41	13.00	2.59
Transmit	Site B	9.5	15.29	7.64	0.76	8.41	2.30		10.71	13.00	2.29

**Figure 8**

information shown (Figure 9) is taken from the Anritsu test printouts and summarized here.

These are the results of tests conducted on a system which is in use in Canada. While the system was not fully loaded (didn't have eight full channels of video), the test results are fully indicative of those for an eight-channel system.

The data shown are the critical parameters for five systems. The RF frequency at 380 MHz is the same for Systems 1 and 2. This is because there are two receiving locations being fed from common transmission equipment.

In conclusion, the FM-FDM multichannel system described can provide cost effective RS-250-B short-haul performance when operated with up to eight channels of video signals and using a system architecture designed to meet these specifications. It will perform over long distances and provides the user with the ability to

transmit signals to one or multiple locations using currently available electronic and optical equipment.

Although this has specifically dealt with RS-250-B short-haul performance with NTSC video, the system is also available for full operation with PAL

and SECAM signals. ■

#### References

1. Electrical Performance Standards for Television Relay Facilities, EIA Standard RS-250-B, Engineering Dept., Electronic Industries Association.

### End-to-end System Test

Parameter	RS-250B					
	Limit	System 1	System 2	System 3	System 4	System 5
RF Frequency (MHz)		380	380	340	240	140
Video Frequency Response*						
Multiburst, 0.5	± 0.1 dB	0.0	0.0	0.0	0.0	0.0
Multiburst, 1.0	± 0.1 dB	0.0	0.0	0.0	-0.1	0.0
Multiburst, 2.0	± 0.1 dB	0.0	0.0	0.0	-0.1	0.0
Multiburst, 3.0	± 0.15 dB	-0.1	-0.1	0.0	-0.1	0.0
Multiburst, 3.58	± 0.1 dB	-0.1	-0.1	0.0	-0.1	0.0
Multiburst, 4.2	± 0.15 dB	0.0	0.1	0.1	-0.1	0.0
Rise Time*	284 ns	135	150	148	141	144
Overshoot*	4.0%	1.0	0.4	0.2	1.2	0.2
Bar Tilt*	1.0%	0.0	0.2	0.3	0.4	0.2
C/L Gain Inequality*	± 1 IRE	0.6	0.7	0.2	0.5	0.1
C/L Delay Inequality*	± 20 ns	-4	-5	-5	-6	-2
Field Time Distortion*	3 IRE	0.4	0.2	0.2	0.3	0.2
Line Time Distortion*	0.5 IRE	0.0	0.0	0.0	0.0	0.0
Differential Gain*	2%	0.83	0.49	0.22	0.55	0.28
Differential Phase*	0.5 deg	0.23	0.22	0.38	0.29	0.17
C/L Intermodulation*	1.0%	0.2	0.2	0.1	0.1	0.2
Chrominance Nonlinear Gain*	1.0%	0.0	0.0	0.0	0.0	0.0
Chrominance Nonlinear Phase*	1 deg	0.3	0.0	0.0	0.9	0.3
Sync Transient*	1%	0.0	0.0	0.0	0.0	0.0
Signal-to-Noise Ratio*	67 dB	71.3	71.3	71.5	72.1	72.0

Measured with Anritsu MG 3118 Video Signal Generator and MG 349D Video Signal Analyzer

**Figure 9**



# More Power to You.

 **Lectro**<sup>®</sup>

## More Efficiency.

In response to operators' concerns over skyrocketing utility costs, Lectro designed and delivered the first Super Efficient power supplies. Now, a complete line of Super Efficient products is available for you.

## More Modularity.

Lectro features plug-in modularity so advanced, so simple that maintenance is a snap! Just ask the man in the bucket.

## More Designs

Lectro has the most diversified product line in the business, ranging from 4 amp to 18 amp. You'll find products to meet every application.

## More Service.

We've been powering cable systems for decades. We back up our service and warranties with field and factory support personnel. *A satisfied customer is our most important asset.*

**CALL 1-800-551-3790.**

In Georgia, call (404) 543-1904

 **Lectro**<sup>®</sup>

More power to you

Lectro Products, Inc.  
420 Athena Dr.  
Athens, GA 30601

Made in U.S.A.

Reader Service Number 39

# Hospital LAN communications

Hospitals maintain a strong commitment to provide the best patient care by improving their internal communications as the technology develops. Today's modern communications systems provide medical professionals and hospital management operations with immediate and accurate patient status. Advanced computer systems are no longer limited to the management or accounting departments, but are now widely used by all hospital personnel for improved internal communications and, more importantly, for documenting and reviewing patient information from remote locations.

This article will particularly focus on the cabling mediums used in hospitals used to connect these services with a special yield to RF broadband technology—a medium that offers versatility, capacity, reliability and bandwidth. Broadband communications technology offers many advantages despite the fact that liability and insurance underwriting issues may exist regarding the proven and acceptable hospital communications standards or methods.

## Overview

All hospitals use and rely on dependable voice (phone) communications controlled by a PBX (Phone Branch Exchange) located within the building. Today, perhaps on an equal basis to voice, data communications has now become an integral part of sharing information. Data communications has become an alternate for voice by using video data terminals (VDT) instead of telephones. Messages and patient files can be reviewed on a terminal screen rather than to have to wait for voice communications.

Video has primarily been used for television entertainment for patient rooms. In addition, video has been used for hospital security, education and video conferencing. Each of these communications services requires a specific cable medium to transport information to its destination.

**Voice.** Voice has traditionally used twisted pair wiring as a means of connecting signals from one point to

another. The medium is of simple construction consisting of two insulated wires spiraled together to maintain constant electrical properties throughout its length and to reduce noise. Radiation of signals can occur and there is a limit to the operating frequency.

Early telephone systems operated on an analog signal approach, where the amplitude and frequency of the voice are converted into electrical waves. Modern telephone systems may use digital signaling techniques, where the voice is encoded into a series of positive or negative electrical pulses and recon-

Television signals are distributed to patient rooms by coaxial cable 'backbone' from the antenna.

verted to normal intelligible signals at the receiver.

The central point of a telephone is the PBX with every phone in the hospital directly connected to it. The PBX is like a matrix switch which can take an inbound line request and connect it to a proper telephone extension number or to an outside line without human intervention (known as point-to-point communication). If a third party joins the conversation, the operation becomes multi-point.

**Computer data.** Computer communications can also use twisted pair wire cabling or low frequency (baseband) coaxial cable concepts. The inner conductor is used for carrying the signals, while the outer conductor is generally at a ground potential providing signal integrity.

The cost of coaxial cable is higher than that of twisted pair wire, but offers better performance, particularly in the use of data. The first improvement is the reduction or elimination of

external electrical interference because of the shielding properties. This is important in areas where strong electromagnetic fields, high voltage equipment or nearby radio transmitters are used.

In some cases, the manufacturer specifies a cabling medium for its equipment. For example "twinax" is specified for IBM's Series/1 local loop networks and Ethernet requires the use of a specially made coaxial cable. However, many data communication systems still use twisted pair wiring as a primary cabling medium.

This architecture is easily designed, economical and quickly installed. It has long been the favored means of connecting remote terminals to the computer mainframe. Other applications may use small diameter coaxial cabling instead. Like the telephone system, all peripheral computer hardware within the building must be individually wired to either a central or remote controller connecting to the mainframe or directly to a mainframe I/O expansion port in the computer room.

## Video communications

Video communications has primarily been used for patient television entertainment, known as CATV in a city environment or MATV for a local campus or single building environment.

Television signals are distributed to patient rooms by coaxial cable "backbone" from the antenna. This backbone is routed throughout the hospital which is branched at each floor level and then tapped periodically to patient televisions, waiting rooms, lounges and cafeterias.

Unlike baseband operation, television systems operate on a broadband principle by frequency dividing each viewing channel into incremental parts of the total usable bandwidth of the coax cable. By frequency dividing the total bandwidth, multiple signals (channels) can be transported over the same cable simultaneously. A broadband cable is vendor independent without regard to what brand of TV or system equipment installed at the antenna headend.

Most hospitals will typically use

By John S. Gutierrez, ComNet Co. and David Philips, Netserv Inc.

# PERFECT STABILITY

INTRODUCING THE



PICO PERFECT TRAP

OVER HOT,  
OVER COLD,  
OVER WET,  
OVER DRY,  
OVER and  
OVER and  
OVER ...

Pico's **New Mini PT** leapfrogs all existing trap technology with an exciting discovery! By using circuitry so advanced,\* in the industry's only hermetically sealed and welded design, the **PT** achieves perfect notch stability time after time, weather or not.

Call for a sample today and test the **Mini PT** — the new standard by which all other traps are judged.

**\*PATENT PENDING**



**PICO PRODUCTS, INC.**

CATV DIVISION  
103 Commerce Blvd.  
Liverpool, NY 13088  
(315) 451-7700  
FAX #(315) 451-7904

Inside the U.S.  
CALL TOLL FREE  
**1-800-822-7420**

Pico's **PT** is the only trap which exceeds the 1990 FCC requirements, established by the Cumulative Leakage Index, by 17dB - 25dB.

# What do TBS and ESPN<sup>®</sup> say is as important as any of the 700 Wegener products? Clear Answers

about six to 10 TV channels covering the local network and independent channels. In addition, some hospitals have added local origination programs, bulletin boards and patient information channels. Because many hospital broadband systems have higher channel capacities than what is allocated, the implementation of unused channels could be used to expand or even modernize hospital data communications without the need for expensive rewiring.

## Broadband

Since Broadband technology has become available for data network communications, the big question has been how will a TV related technology blend into a data communications environment for a long term commitment? Though fiber optic technology is the current state-of-the-art in data communications, it does not have the varied service flexibility of broadband systems. An RF broadband cable system

offers substantial networking capabilities that go beyond TV entertainment for the patient.

Broadband technology is no longer limited to cable television, but over the last 5 years broadband has solved many communications problems and has brought Local Area Networks a real meaning. Yet many people today do not fully realize the full potential of this type of communication system because it is commonly thought that broadband was for cable television, not computer communications.

In a baseband system, adding or re-locating equipment resulted in additional cabling requirements that culminated in a wiring "nightmare" with old cables being abandoned, leaving a graveyard of inactive cables in the ceiling. Cable TV technology revolutionized data network systems.

Broadband systems have a proven track record of reliability. A broadband system can provide years of trouble-free service when coupled with a simple routine maintenance program. Broadband components have a life expectancy of over 35 years between failure, even in harsh environments. A properly installed broadband system is immune to external electrical interferences, including grounding problems commonly found in baseband coaxial systems.

RF broadband networks have total bandwidths in excess of 400 MHz and can be divided or segmented into many individual channels of varying bandwidths for use in data, video or voice.

## Baseband and broadband differences

There are two methods LANs use to convey information. The first is baseband and the second is broadband. The first is simpler, cheaper, less sophisticated, but limited. The second is initially more expensive, harder to design, needs to be maintained, but, when used effectively, is more versatile, can reduce re-wiring costs and can eliminate the need to install new cables.

In baseband, signals are applied directly onto the cable without a modulating carrier; much like connecting speaker wires to a stereo. Telephone, data terminal equipment and PA voice cabling use this approach. The main problem with this is that no other devices can share the same connection simultaneously without causing severe interference. However, there are ways to solve this problem, which will be discussed later.

Broadband systems transmit signals



## BROADBAND LAN

modulated by an RF carrier which is assigned to a certain channel before being placed on the cable. Broadband networks have frequency bandwidths typically exceeding 400 MHz. The total bandwidth is subdivided into channels of which 6 MHz is allocated to each. The channels on a broadband network are kept apart by frequency multiplexing.

By assigning 6 MHz per channel, a 400 MHz system could ideally provide 66.66 6-MHz channels on a single cable system. Many RF modems only occupy a fraction of the whole channel, therefore, the same 6 MHz channel could be partitioned into "sub-channels."

For example, a 19.2 KB/s voice or data circuit only needs 50 kHz of frequency space, which means that 120 19.2-KB/s circuits could be placed within a single 6-MHz channel providing 60 full duplex conversations simultaneously and on the same cable that carries TV channels to the patient rooms. By using frequency multiplexing, many types of services can share a single coax cable using broadband technology.

### Baseband protocols and modems

Although baseband systems could be designed to frequency multiplex signals at different tone frequencies, data transfer rates would be severely limited and video signals would be difficult or impossible to transmit. It is beyond the scope of this article to discuss these limitations, however, the main point is that baseband suffers from the inability to integrate multiple information systems for simultaneous transmission.

A data system with multiple devices can share a baseband cable system by using a modem with a set of communication protocols which provides cable access in an orderly fashion. A modem is an interface unit that couples the data information from a data port onto the baseband cable at the appropriate interval. Access to the coax is controlled by a protocol set built into the modem.

Most baseband LANs which share the same coax cable, such as Ethernet, use a "listen before talk" rule set. Modems attached to the network all have unique calling addresses and will not "talk" until called for by another modem. Before any modem commences, a call following a user request "listens" before transmitting. If the line is clear, a call information packet is transmitted.

If, on the other hand, the line is occupied by another modem's transmission, the modem will "back off" and not transmit. The modem back-off time is random and will retry at the expiration of the countdown. When the modem finally gets a chance to transmit, it will listen for a short time to insure that its transmission was not interfered with. Should another modem transmit at the same time, the modem will "jam" the line with a special

signal that causes everyone on the LAN to back off, and the whole cycle is again repeated.

As the modem transmits, it listens to itself and will timeout a period in which the modem being called must respond. Failure of the called modem to respond to a call could be caused by a cable fault or because the modem or terminal is not on-line. This described form of transmission is called CSMA/CD (Carrier Sense Multiple Access/



**"MY CHALLENGE was to find the best stereo encoder. Our California market demanded state-of-the-art equipment."**

**"THE CLEAR ANSWER,** after looking at 10 manufacturers, was Wegener. We now have about 170 Model 1602-95 stereo encoders spread throughout the region and they're excellent. While Wegener offers great support, to date, the product hasn't given us a single problem. We're already testing another Wegener product, an AGC add-on board to guarantee uniform output levels from variant input sources. The way Wegener designs and builds its products, I'm sure we'll add more Wegener equipment."

For a clear answer to your stereo encoder or other transmission challenges, call Steve Fox at Wegener Communications.

**"There is only one clear answer..."**

Reader Service Number 42



**WEGENER COMMUNICATIONS**  
TECHNOLOGY PARK/JOHNS CREEK  
11350 TECHNOLOGY CIRCLE  
DULUTH, GEORGIA 30136

(404) 623-0096 TELEX 54-3634 FAX (404) 623-0698

*Al Kuolas, Regional VP Engineering  
for Continental Cablevision, the  
nation's 3rd largest MSO.*

When you need to

**CORE IT...**

**CRIMP IT...**

**STRIP IT...**

make sure you  
have the  
right tools!

•CST COMBINATION  
CORE & STRIP  
TOOLS



•CR CRIMP TOOLS



•JST JACKET  
STRIPPERS



•UT DROP CABLE  
STRIPPERS



Made in USA

Time-tested quality tools from Cablematic — the respected name in Cable Preparation Tools for over 25 years.



**RIPLEY  
COMPANY, INC.**  
CABLEMATIC™ DIVISION

46 Nooks Hill Road  
Cromwell, Connecticut 06416  
Tel. (203) 635-2200 FAX: (203) 635-3631

Reader Service Number 43

## BROADBAND LAN

Collision Detection), standardized by IEEE 802.3.

This baseband approach is OK if only one type of service is planned for the cable medium. Placing video or audio on the same coax would disrupt all communications. Other baseband protocols such as Token Bus or Token Ring, which circulate a token from modem to modem, was standardized by the IEEE 802.4 and IEEE 802.5 committees.

Token protocols require that any modem placing a call must first wait for the token. Token ring networks may be desirable for those applications where modems are required to transmit in a predictable order. An example of this would be a manufacturing assembly environment, which are often hostile to baseband performance because of electrical noises created by welding apparatus.

Most coax baseband systems operate at transmission transfer speeds of 2 MB/s to 10 MB/s (megabits per second) with medium lengths limited to 1,500 meters. Their twisted-paired counterparts nominally transmit from 1,200 B/s to 19,200 B/s (bits per second) with medium lengths to 1,000 feet, depending on the data transfer speed and ambient electrical noise. Special digital telephone circuits called T-1 lines can operate as fast as 1.544 MB/s. T-1 circuits are primarily used for long distance point-to-point communications.

### Broadband modems

Broadband modems are similar to a baseband modem, except that a broadband modem has a radio transmitter and receiver. The transmitter functions to convert the outgoing signal onto an assigned carrier frequency, while the receiver recovers the signal component by tuning to the transmit carrier frequency.

Broadband modems can share the same channel by using the CSMA/CD and token passing protocols described above. In addition, communications can be configured on dedicated channels for point-to-point connections. Each broadband modem can be assigned a specific operating frequency for con-

tinuous transmission without causing interference to other services on the cable system. Video transmitted on a broadband system use a device called a video modulator.

Modulator output carrier frequencies can either be fixed or agile. Video receivers are called demodulators.

### Video services

The hospital television cable system can also be considered a simple Local Area Network. The principle difference between a TV cable system and a broadband data system is that the communication of a TV system is only one-way, from the antenna to the television set. Hospitals have always used this technology exclusively.

Local off-air channels or local cable TV channels are inserted into the broadband system for distribution throughout the hospital. To the hospital's advantage, much of the television system bandwidth is not used and is available for other hospital communication services.

### Why use broadband?

Broadband cabling is a type of Local Area Network used to interconnect computers, controllers, disc drives, printers, programmable devices, patient monitoring equipment, remote diagnostic equipment, televisions, cameras, voice and many other equipment types simultaneously. The broadband network uses a 75-ohm cable-TV coaxial cable for its signal media. The broadband system is configured with splitters that branch the paths in multiple directions with taps installed to connecting all types of communication devices (modems or TV sets).

RF amplifiers are also connected periodically to offset the insertion loss of the signals passing down the length of the coax cables, splitters and taps. This media offers a wide bandwidth (5 MHz to 600 MHz), long distance (greater than 20 km) and long life (35 years).

The significance of a broadband architecture is the elimination of bulky cables between end devices to a control center. A broadband system uses a

Broadband modems  
are similar to a  
baseband modem,  
except that a broadband  
modem has a radio  
transmitter and  
receiver.

# When yesterday isn't good enough.

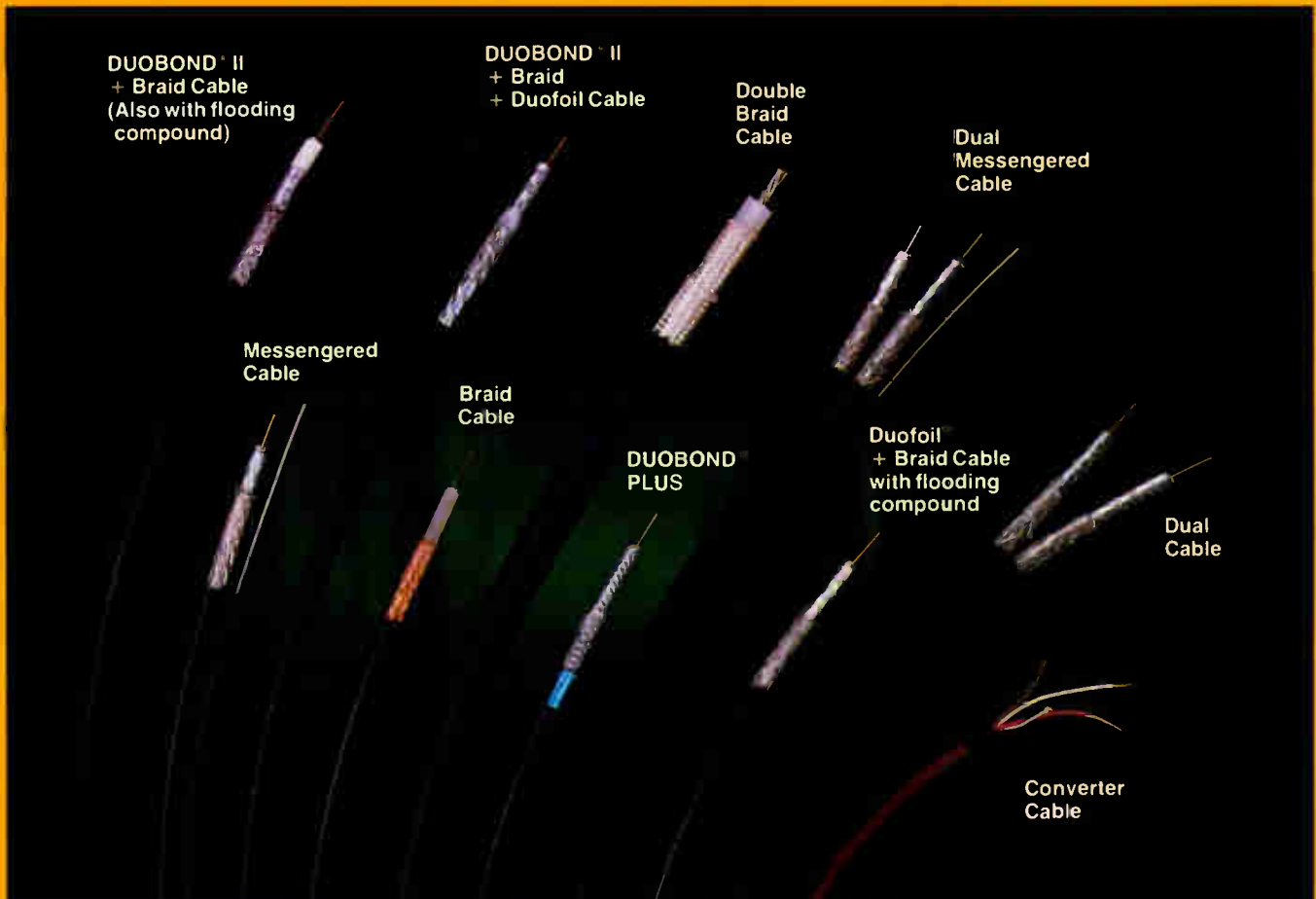

## Anixter Cable TV stocks Belden drop cables

*SERVICE.* So many suppliers use that word. But only one lives up to it. Anixter Cable TV. Anixter stocks the complete line of Belden drop cables, ready for immediate delivery from a location near you. No minimum orders...and no minimum quantities. Just Belden quality. Every day.

Visit Anixter Booth #141 at the Atlantic Cable Show

**ANIXTER**  
CABLE TV

Reader Service Number 44

**WEST-ANAHEIM:** (714) 779-0500, (800) 854-0443; **DENVER:** (303) 740-8949, (800) 841-1531; **SEATTLE:** (206) 251-6760, (800) 426-7665; **MIDWEST-CHICAGO:** (312) 364-7000, (800) 544-5368; **CLEVELAND:** (216) 526-0919, (800) 321-8068; **DALLAS:** (214) 446-7337, (800) 231-5006; **IRON MOUNTAIN, MI:** (906) 774-4111, (800) 624-8358; **SKOKIE, IL HDQTRS:** (312) 677-2600; **EAST-ATLANTA:** (404) 995-5110, (800) 241-5790; **LONG ISLAND, NY:** (516) 293-7788, (800) 645-9510; **NEW JERSEY:** (201) 328-0980, (800) 631-9603; **TAMPA:** (813) 626-7115, (800) 282-9164; **CANADA-CALGARY:** (403) 250-9646; **MONTREAL:** (514) 636-3636; **TORONTO:** (416) 625-5110; **VANCOUVER:** (604) 321-5885.

In an emergency, weekends and holidays or after 5 P.M. call toll free 1 (800) 323-8166.  
CORPORATE OFFICES, ANIXTER CABLE TV, 4711 Golf Road, Skokie, IL 60076, (312) 677-2600

©1989 Anixter Cable TV

# Genuine Jackson Tools

Cable Block

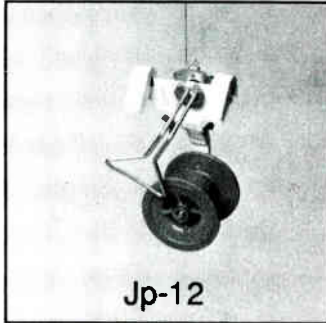

Jp-12

90° Corner Block

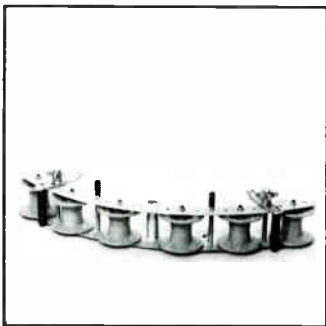

We offer a 3 year warranty

Call Us Today For Your Aerial Fiber Tool Needs

Jackson Tools Systems

PO Box 6  
Clayton, OH 45315  
(513)836-2641  
FAX (513)836-0396  
Reader Service Number 45

## BROADBAND LAN

short wall drop cable connection to a coupling interface from a tap located along the main cable routing.

This method permits many devices to share the same cable medium simultaneously. Equipment can be easily

networks on the same cable are desired. Another issue involved in broadband network design is the selection of amplifiers for low overall signal degradation on the cable. The cable, taps and splitters cause signal losses to occur.

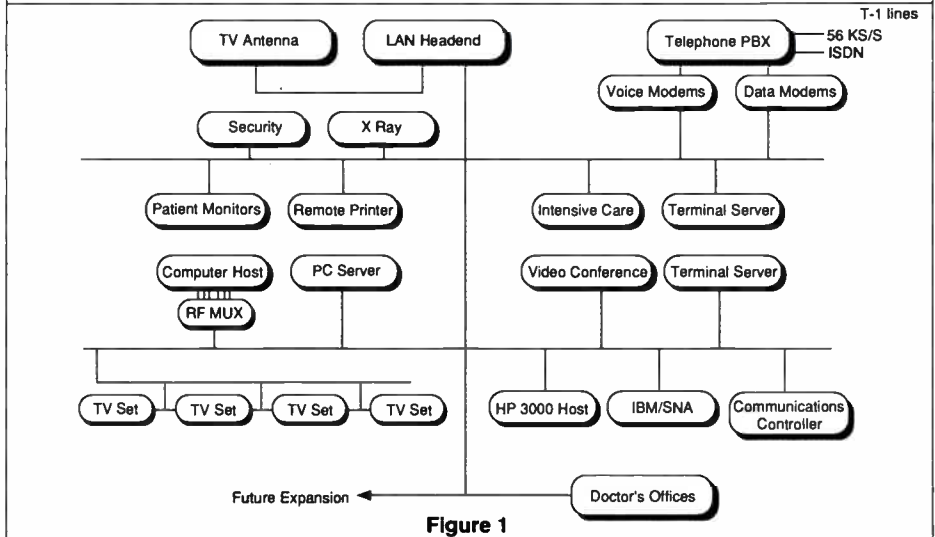

relocated without major re-cabling. In this scenario, a broadband cable medium is a "wire once" concept, vendor independent, transparent to other users, multi-functional and expandable without re-design. A typical broadband Local Area Network cable configuration is shown in Figure 1.

A broadband cable system is composed of a variety of taps, splitters and amplifiers attached to a 75-ohm coaxial cable. The cable has a large bandwidth divided into as many 60 channels. Only one transmit channel and one receive channel is necessary for a network. It is the responsibility of a network manager to organize and assign the set of channels television, data and voice that the network will use.

More than one pair of channels or frequencies can be assigned if separate

These losses occur as the signal travels along the length of the cable, and become greater as the channel frequency increases.

For example, a television tuned to channel 2 receives a clear picture on a cable length of 300 feet from the insertion point. If the television is tuned to channel 13, and given the same input level at the insertion point, the received picture would be extremely noisy or "snowy" because of the signal losses imposed by the cable. It is the designer's job to design the system with appropriate amplifiers to balance the system and keep the signal from becoming too low.

Designing a cable system has become easier with the availability of computer software packages that can properly design a broadband system

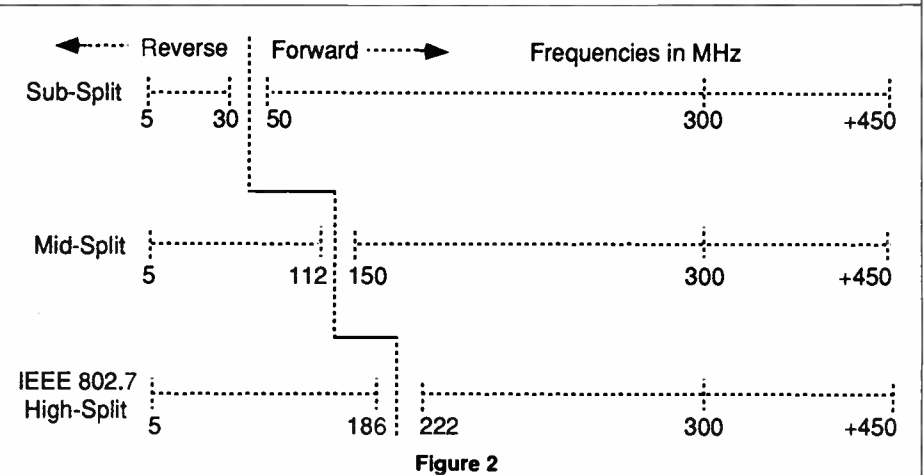

# Z-VIEW. THE PAY-PER-VIEW SYSTEM THAT PROMISES MORE THAN JUST THE STARS.



It's true that with some PPV systems, subscribers can enjoy heavy star-gazing. But with the Zenith Z-View system, they can set their sights even higher. That's because Z-View's two-way addressability provides a true, real-time link between you and your subscribers. A link that makes possible more than just simple, remote control PPV event access for your subscribers.

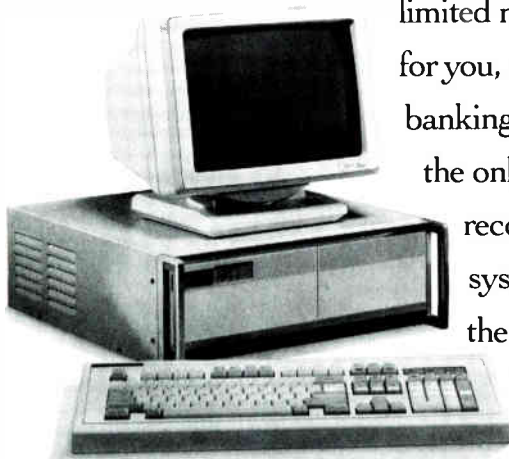

But also, unlimited marketing opportunities for you, such as channel monitoring, home shopping and banking, and opinion polling. Zenith's Z-View is the only real-time PPV system that has a proven track record of over five years of reliable service in cable systems throughout the country. The Z-View signals are protected with SSAVI baseband scrambling for maximum security. Plus, rugged upstream data transmission allows for effective communication even in the most demanding cable plants. So why settle for the stars when you can have the whole galaxy?



Write or call for more information on the Z-View system and other Zenith cable products: Zenith CATV Sales, 1000 N. Milwaukee Avenue, Glenview, Illinois 60025. (312) 391-7702.

**ZENITH** | **cable products**

*ADDRESSING YOUR FUTURE TODAY*

## BROADBAND LAN

with predictable performance over the entire bandwidth.

### Bi-directional cable networks

Broadband systems used for television reception use the entire bandwidth in the forward direction along the cable.

However, a data or an interactive implementation requires that the cable bandwidth be divided into two functional bandwidths, forward and reverse. This is done by the use of special bandpass filters and amplifiers.

Many broadband LANs were implemented as mid-split systems, but as the broadband LAN became desired, a high-split architecture emerged.

The high-split offers a more symmetrical bandwidth capability in the forward and reverse directions than the mid-split. CATV has and will continue to use the traditional sub-split because of channel programming. All three are shown in Figure 2.

Although the crossover gaps between the mid frequencies can vary to a small degree between amplifier vendors, most mid-split broadband LANs can provide at least 16 or 17 reverse channels and as many as 21 forward

channels on a 300 MHz system. More channels are potentially available on the forward side of a mid-split system if it has capabilities to 450 MHz using the standard 6 MHz video slots.

Availability of additional reverse channels may be accomplished with the use of a high-split system which can supply up to 30 reverse channels and at least 35 forward channels if 450 MHz of bandwidth is used. At first, this may sound like a tremendous amount of bandwidth, so there is a tendency among LAN planners to put services anywhere indiscriminately. It is recommended that a frequency or channel allocation plan

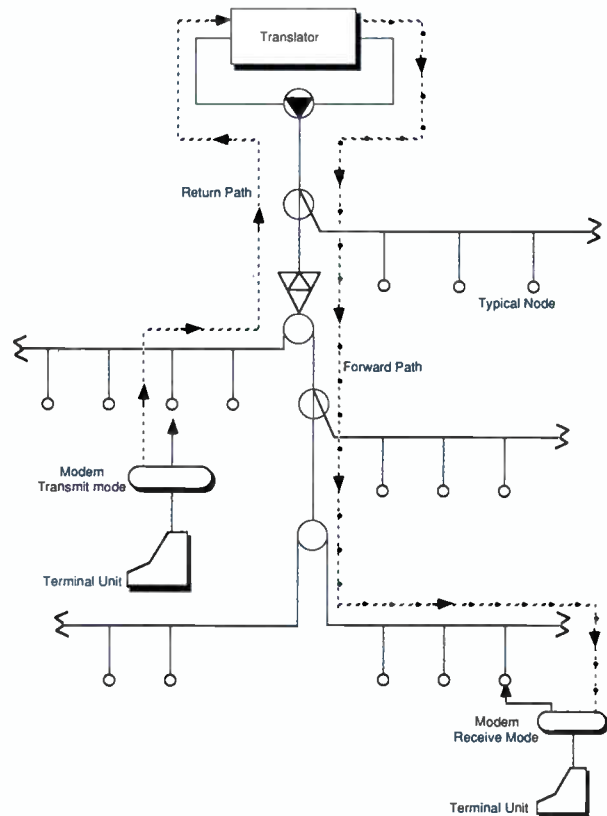

Figure 3

# You Deserve Quality...

## Linegear & Headend Equipment from Cable Link, Inc.



**(614) 221-3131**

**Buy, Sell, Repair,**

**converters, line amps, line extenders, headend, traps, parts**

## BROADBAND LAN

be developed.

### Network topology

All hospital television systems begin with a focal point of distribution, typically located in a utility room near the antenna feed. In networking and CATV terminology, this is called the headend. The location of the headend is an important first step in establishing the topographical shape of a broadband network.

All hospital television systems begin with a focal point of distribution, typically located in a utility room near the antenna feed.

From the headend, the main trunk cable is routed into the building riser(s) passing by each floor level. Floor distribution is branched from the trunk by the use of splitters or directional couplers. The floor cable distribution can be further branched by using splitting devices until the terminating point is reached. This "tree" topology is the most widely used in broadband networks.

The headend of a television system consists of antenna pre-amplifiers for signal conditioning, UHF-to-VHF converters, channel mixing combiners, and a main distribution amplifier. Television distribution systems are designed to operate as one-way networks by delivering signals from the antenna to TV set only.

The headend of a broadband interactive data network operates as a two-way or bi-directional system with forward (outbound) and reverse (inbound) paths using the same cable. Two-way communication is formed by fragmenting the total system spectrum into two major bandwidths. Devices attached to the network transmit only in the return frequency band. All signals inside the return band are received at the headend and converted up to signals with a higher frequency by a device called a translator. These higher frequency signals, which now occupy

VERSALIFT

# GAIN MORE SIDE REACH AND BETTER LINE ACCESS WITH THE NEW TEL-29EA

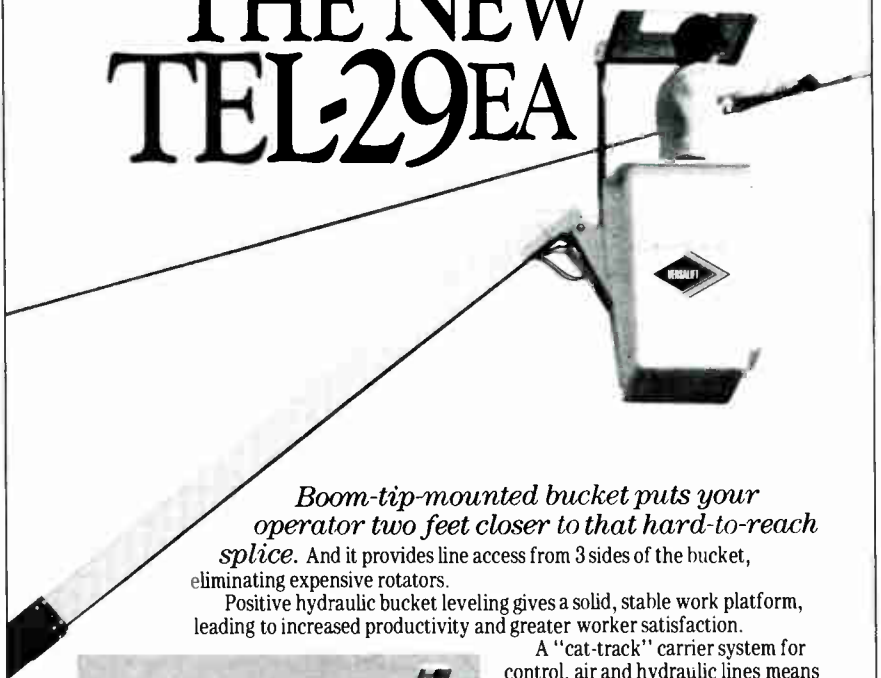

*Boom-tip-mounted bucket puts your operator two feet closer to that hard-to-reach splice. And it provides line access from 3 sides of the bucket, eliminating expensive rotators.*

Positive hydraulic bucket leveling gives a solid, stable work platform, leading to increased productivity and greater worker satisfaction.

A "cat-track" carrier system for control, air and hydraulic lines means less maintenance, more "up-time."

The VERSALIFT TEL-29EA can be mounted on any 10,500 dual rear wheel chassis with 60" C.A. and can be tailored to meet any aerial work requirement.

See your VERSALIFT Distributor for complete specifications, pricing and a demonstration!

**It's TIME to  
check out VERSALIFT!**

  
**TIME**  
MANUFACTURING COMPANY

P.O. Box 20368 Waco, Texas 76702-0368  
(817) 776-0900 TELEX (910) 894-5218 FAX (817) 776-7531



TEL - 29EA  
Reader Service Number 48

# VERSALIFT

on a central point at which the central switching equipment is located. This type of network is relatively immune to serious consequence resulting from the failure of a single link, since such a failure would tend to impact only a single user of a single service.

On the other hand, such a conventional network is vulnerable to problems affecting the centralized switching equipment, particularly since such equipment is complex enough to troubleshoot, and its expense prevents it from being provided in fully redundant form.

The vulnerabilities of a bus-based distributed intelligence network are reversed. There is no centralized switching equipment serving the entire network. In the case of broadband networks, the relative low expense of the headend equipment permits redundancy, and its simplicity promotes high reliability and rapid fault isolation. Instead, a bus-based network, such as Ethernet, is vulnerable to problems affecting the bus. If the main cable is severely pinched or kinked, its electrical characteristics may be altered at the damaged point, causing a serious impedance mismatch.

This mismatch can cause unwanted

reflections to occur resulting in the device colliding with its own transmission each time it tries to transmit. A cable discontinuity has a similar effect, since either a short or break in the cable affects the minimal impedance.

**In the case of  
broadband networks,  
the relative low  
expense of the headend  
equipment permits  
redundancy...**

Isolating and correcting the problem can be time consuming; the failure can appear to be anywhere.

Broadband cable has a different impedance characteristic and operates in an RF mode rather than in baseband. Therefore, a short in the cable would isolate a particular branch or

segment which can be easily identified and corrected. Broadband distribution can be designed with semi-rigid cable having an aluminum shield or even better protected with a sheath of armor for rugged areas. For extra measures of reliability, the system can be designed with amplifier redundancy and system status monitoring.

### Network applications

Broadband modem manufacturers made their marketing debut by supporting asynchronous terminals with various transfer rates and distance coverage using CSMA/CD or /CA. Primarily the competition centered around the VAX installations where asynchronous terminal expansions were on the rise in campus-like or large building environments. In addition, there were needs to share devices like printers, disk drives and host computers among the users.

Electronic mail is now a popular means of sending messages to one another, to department groups or even globally to every network user. The acceptance of broadband for LANs has provided fresh communication options for businesses, and hospitals may now recognize this as a viable method for their communication needs. A terminal can be relocated by simply unplugging the modem from the wall outlet and reconnecting the modem and terminal to a new location drop outlet, much like moving a TV set. Broadband LANs in most buildings are designed with a service grid area so that a user outlet is within a 50 foot radius from the cable system tap, regardless of wall configurations.

In most recent developments, broadband modem manufacturers now offer support for the IBM 327X requirements by the use of SNA protocol converters. Although IBM also competes for networking technology, their LANs are generally not broadband based and focus on IBM products only. A broadband LAN's greatest advantage over baseband is that it can support heterogeneous services simultaneously over a single coax.

Many LAN companies are offering small business the opportunity to implement LANs as an economical approach to sharing computer hardware such as printers and servers or software programs. Many of these LANs are PC based and are limited to baseband operations where broadband is not indicated for varied services.

Broadband LANs have the capacity

# CLI Maintenance Tool

## Torque Wrench

Improper connection of the F-Connector is the #1 problem that leads to CLI signal leakage.

Using a Multilink Torque Wrench can insure proper connectorization and signal contact with the F-Connector at a minimum cost.

**Call us for your nearest  
Multilink representative**

196 Morgan Avenue  
P.O. Box 955  
Elyria, Ohio 44035  
Office & Plant (216) 324-4941  
Fax # (216) 324-4947

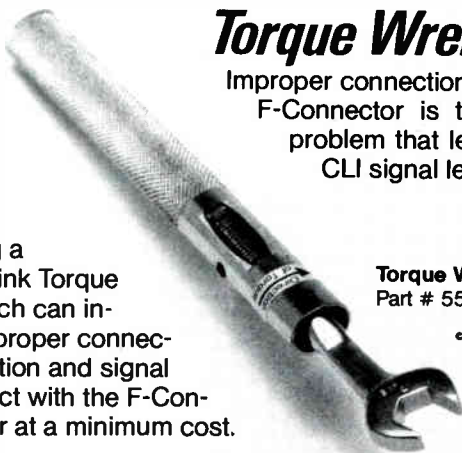

**Torque Wrench**  
Part # 5525-TWD

© Aug. 1989





## BROADBAND LAN

to transport patient X-rays electronically. X-ray films, once converted into saved data, can be retrieved by data imaging processors and scanned onto a remote terminal, even though the same terminal device might be a personal computer. Hospitals often have doctor/medical facilities adjacent to the building. These offices could be attached to the broadband LAN so that doctors access patient information, advise of medical orders or tune in on special access continuing educational chan-

Remote patient monitoring offers cost reduction advantages for both hospital operations and the patient while leaving the ICU available for those who need it the most.

### Security aspects

Just as in remote patient monitoring, hospital security of lobbies, secured passageways and parking lots can be attached to the broadband LAN

on specific channels assigned to security operations. Many hospitals have installed new security cameras yet overlooked the use of the existing broadband cable system to save installation costs.

A hospital broadband LAN can also serve patient television sets. Local or selected cable channels can be carried on the forward side of the broadband LAN for signal distribution throughout the hospital. ■

Remote patient monitoring has been primarily limited to intensive care units.

nels. These special communication services can be billed for LAN access time as a hospital revenue source.

### Teleconferencing possible

Using enhanced PCs with a camera and sound equipment, video teleconferencing is possible. Video conferencing to other LAN users within the hospital or medical centers across the country is made possible by remotely accessing local equipment attached to T-1, Switched 56, ISDN, etc. Video conferencing can also support sending high-resolution screen images such as pictures, graphs and text.

Remote patient monitoring has been primarily limited to intensive care units. ICUs are generally pre-wired with the manufacturer's recommended configuration to all monitor devices and all wiring is confined to the care area.

However, in some cases, there may be a need to monitor a patient from a remote location. The patient can be comfortably attached to monitor sensors or viewed from a slow-scan camera where the equipment simply attaches to the broadband network. The patient(s) can now be observed and remotely monitored at any nurse station.

Fact.  
Fact.

CLIDE is the **first** CLI management software fully approved by Wavetek for CLM-1000 compatibility.

CLIDE offers the following **standard** features:

- 13000 calculation method
- Leak Cost Analysis Reports
- CLI Reports
- User-friendly screens, with pop-up menus and windows
- CLIDE to CLIDE file transfer via telephone modem
- Easy installation
- Novell networkable
- Compatible with Wavetek CLM-1000

leakage Detection Meter, Psion hand-held computer, and Tandy RS-102 laptop computer.

Fact.

Wavetek has selected CLIDE as **the** CLI management software to accompany their CLM-1000 leakage Detection Meter.



**CLIDE for CLI —  
No less, no more.**

Telecommunication  
Products Corporation

1331 South 7th Street  
Chambersburg, PA 17201

Reader Service Number 51

# Surge suppressors: The story behind clamping voltage

**S**urge suppressors, UPS systems, line filters, power conditioners, and isolation transformers all exhibit strengths and weaknesses in the broad field of "computer grade power conditioning." In order to evaluate a particular need, the limitations of the power conditioning products available on the market today must be understood. This article covers the application of surge suppressors on alternating current (AC) power circuits. The surge suppressor is the most needed, cost effective and, therefore, the most commonly used power conditioning device.

A surge suppressor's primary function is to eliminate overvoltages. The suppressor will utilize suppression components such as gas-tubes, metal oxide varistors (MOVs), thyristors or silicon avalanche diodes, between the power circuit conductors. For example a 120/208 volt AC three phase four-wire suppressor should have suppression elements placed between each of the three phase conductors and suppression components placed between each phase conductor and the system neutral. If the device is placed at a sub-panel location, an additional suppression element is necessary between the system neutral and the non-current carrying system grounding conductor.

Suppression components are voltage dependent devices that vary their impedances with respect to voltage, therefore, acting as a current shunt. Once the suppression component has lowered its impedance as a result of an overvoltage, the conduction of the surge current and AC power frequency current will begin. The current through the suppressor and the connecting wire will develop a voltage drop across its terminal. This voltage drop is referred to as the suppressor's clamping voltage. It is important to realize that the clamping voltage is 100 percent dependent upon the nature of the surge current that it is suppressing. Some of the variables of the clamping voltage are the rise time, peak amplitude and varying characteristics of the current pulse.

*By Ron Chapman, Vice President, Advanced Protection Technologies*

The surge suppressor is the most needed, cost effective and, therefore, the most commonly used power conditioning device.

Underwriters Laboratories has a listing for surge suppressors under UL 1449, a standard for safety transient voltage surge suppressors. The Listing is primarily a safety standard, but it does use ANSI/IEEE C62.41-1980 [formerly IEEE-587]. (C62.41 is presently under a total revision, (in its ninth draft) standard for surge voltages. UL

The clamping voltage using the 8 x 20  $\mu$ s 3KA pulse will not reflect any reactive voltages in the suppression element or the connecting wire. Evaluating a surge suppressor on the C62.41 clamping voltage rating alone can be very misleading.

Figure 1 illustrates a surge suppressor with a rated clamping voltage of 500 volts. The 500 volts is the clamping voltage of a standard 130-volt metal oxide varistor when tested with the 8 x 20  $\mu$ s 3 KA current pulse. For the purpose of this example, we will assume that the surge suppressor will utilize a total of six feet of #12 AWG Thhn solid copper wire in the connection of the suppressor to the electrical service panel.

If the suppressor was subjected to a 10,000 ampere lightning induced current pulse, with a 1  $\mu$ s rise time, the clamping voltage would be equal to: 9,000 volts on the first lead length + 500 volts (hypertetically clamping voltage of the suppressor) + 9,000 volts on the second connecting lead length, for a total clamping voltage of 18,500

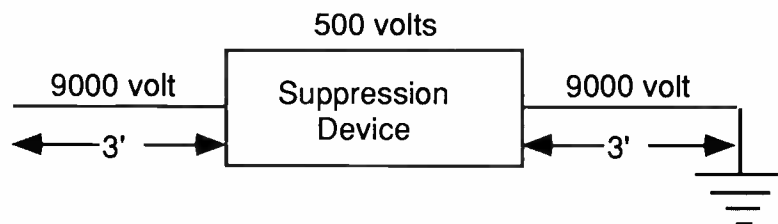

Figure 1

1449 utilizes C62.41 as a means of defining the suppressors into clamping level groups. C62.41 defines a 3,000 ampere current pulse to be applied to the suppressor and the voltage drop measured across the terminals is the clamping voltage.

The current pulse used is an 8 x 20 microsecond current pulse. This means that the current rises to its peak value in 8 microseconds and declines to 50 percent of the peak value in 20 microseconds. It is important to realize that this current pulse is a low frequency current pulse, meaning that it exhibits a slow rise time.

The 18,000 volts developed in the connecting wire is a result of  $E = L \frac{di}{dt}$ , where  $E =$  volts,  $L =$  the self inductance (measured in microhenrys) of the wire,  $di =$  the peak current and  $Dt =$  the rise time of the current pulse. From this illustration we can see the importance of minimizing the connecting lead length and also any internal inductance within the suppressor.

Figure 1 illustrates a realistic example of a lightning induced current pulse that is expected to appear at the service entrance of a facility. It is important to realize that under this condition the suppressor would have a "let-through"

# REMEMBER THESE ADS?

**T**HEY FIRST RAN IN 1985. We brought them out again to remind you we've been talking about signal security for nearly five years.

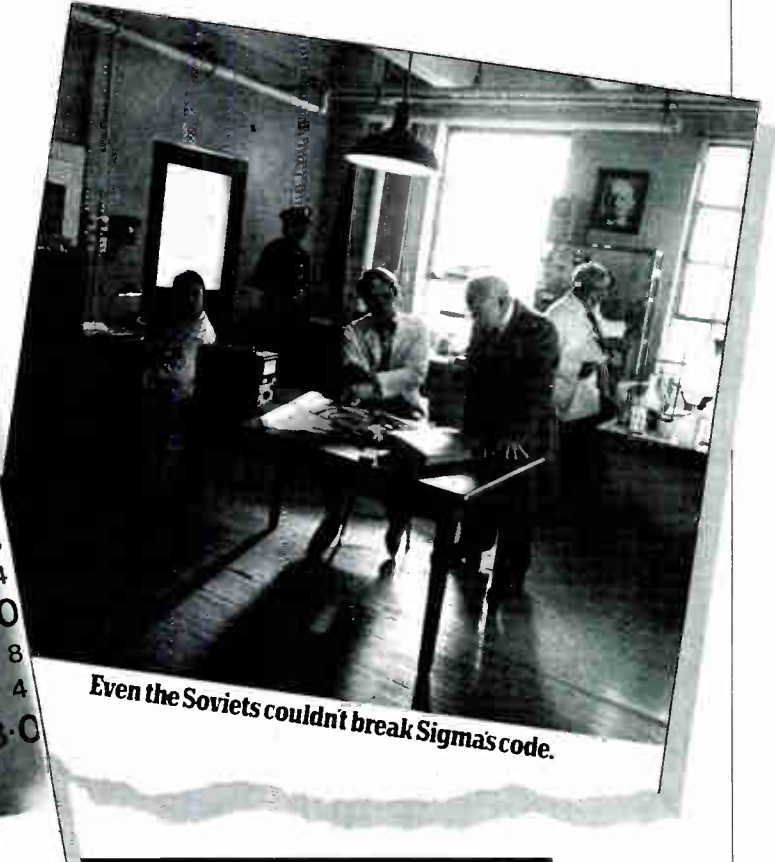

No other addressable system can protect your revenues like Oak Sigma. With over half a million units shipped, Sigma's encryption-based encoding has never been cracked. Never.

No other manufacturer of home cable (or satellite) security products can make that statement — not even for some of their "brand new" models.

Getting serious about signal security is just good business. Especially now that cable's most secure addressables

cost no more than some virtually defenseless systems. If you're making a multi-year security system investment, can you risk having anything less?

If you're ready to get serious about security, call us to arrange for a no-obligation demonstration of the toughest signal protection available — Oak Sigma.

**CDANK** Communications Inc.  
16516 Via Esprillo • Rancho Bernardo, CA • 92127 • (619)451-1500

## SURGE SUPPRESSORS

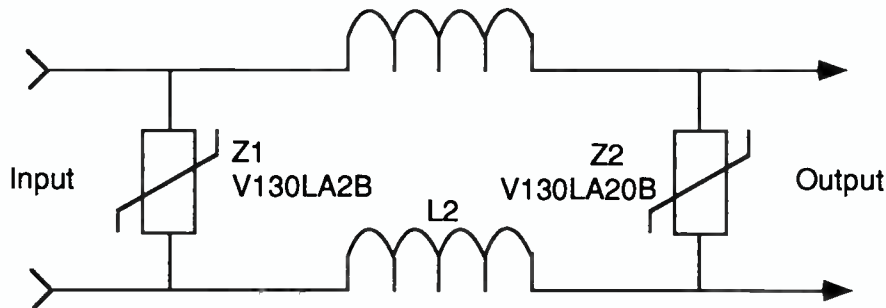
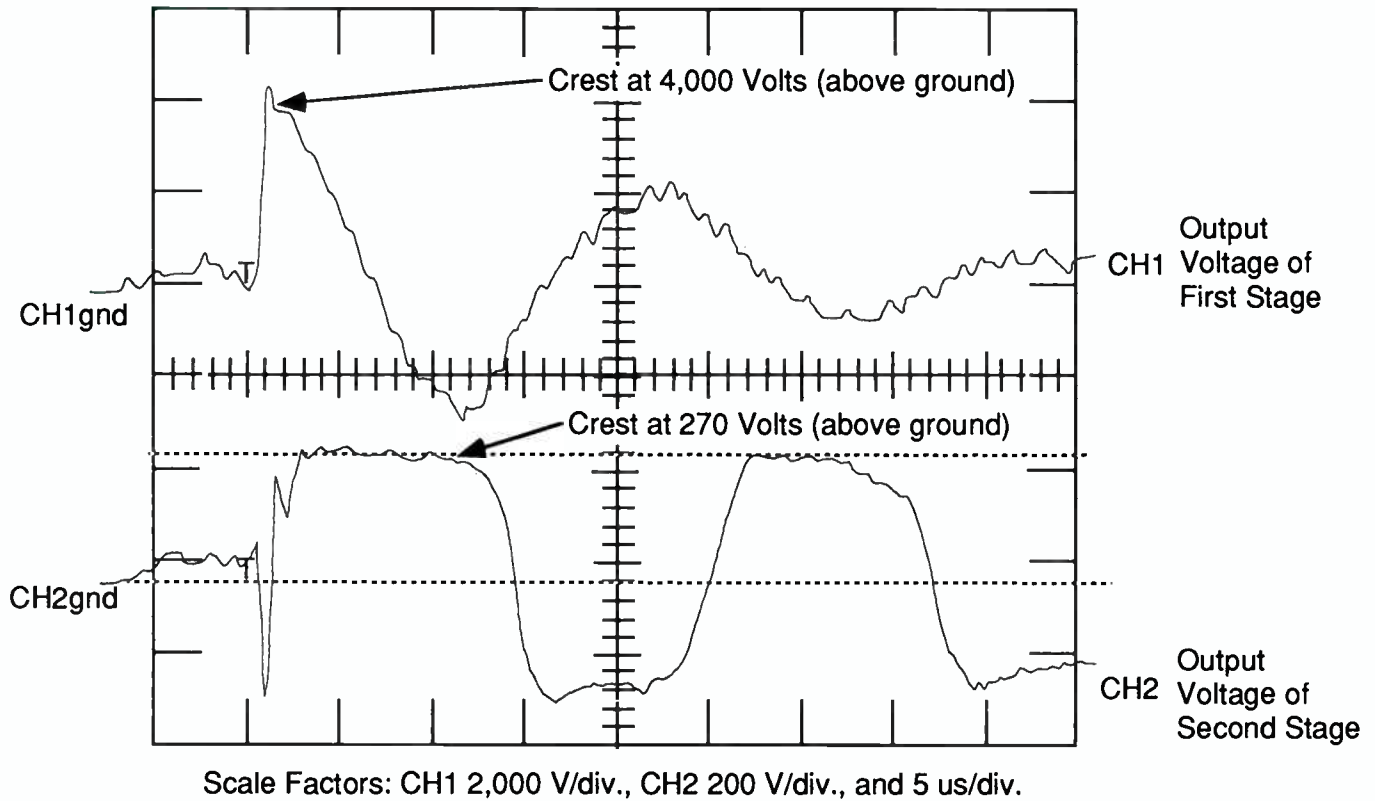

Figure 2

voltage or a voltage residual of 18,500 volts that the equipment within the facility would be exposed to.

Let's now take a look at Figure 2. In this example we utilized two metal oxide varistors (suppression elements) and connected them in parallel to 50 feet of #12 AWG copper wire. We then injected an input surge current with an amplitude of 10,000 amperes exhibiting a rise time of 2.5  $\mu$ s. The scope trace reflects a measurement of 4,000 volts at the output of Z1 and 270 volts at the output of Z2. This example illustrates to show the effectiveness and necessity of the "stage concept."

**A surge suppressor's primary function is to eliminate overvoltages.**

Z1 is respective of a suppressor placed at the sub-distribution panel or in some cases a wall-outlet. The varistor located at the input "shunted" 97

percent of the induced surge current. But in the process, a large voltage drop was developed across its terminals (4,000 volts). This voltage was felt across the terminals of the varistor Z2 which also became a much lower impedance but offered a much lower clamping voltage at its output because it only suppresses 3 percent of the applied surge current.

A lot of failures in the field are a result of suppressors utilizing excessive lead length to connect the suppressor to the panel board or the failure to utilize two suppressors in high lightning prone areas. ■

# THE SOUND INVESTMENT

## )))IN STEREO(((



It's a tough market out there and the smart money goes with a sure thing whenever it's available. That's why more top MSO's put their money on Leaming audio equipment. It has the proven assets to return a high yield of performance and reliability.

It's clear why the industry is bullish on Leaming equipment. Products like the MTS-2B BTSC Stereo Generator offer more standard features than any comparable unit and at a very comparable price.

Sharp, clean audio with a frequency response flat out to 15 kHz, typical stereo separation >30 dB, true AGC, Bessel-null test-tone, dbx® noise processing, and stereo synthesis for ad insertion are basics that Leaming buyers have come to expect.

This is the kind of dependable equipment that operators want to have on-line for the not-so-far-away day when every minute of broadcast time will be in stereo.

So, if you're in the market for success, take this insider tip and call or write today for more information on the full line of audio equipment. Make Leaming your next sound investment.



15339 Barranca Parkway, Irvine, CA 92718  
(714) 727-4144 • FAX (714) 727-3650

THE MTS-2B IS PREFERRED BY MORE TOP MSO'S THAN ANY OTHER ENCODER

COMPLIANCE



receive any maintenance until a subscriber calls with a complaint. To make matters worse, the drop work is often performed by personnel with the least amount of training.

Poor quality installation work can create weak points in the drop system that eventually wear out and cause problems such as signal leakage (egress) and ingress. In addition, the cable operator has little control over what is connected to the drop cable inside the house.

The list of problems above that affect the trunk and feeder can also affect the drop network. Additionally, the following items can be added for drop related leakage problems:

- Illegal hook-ups or second outlets. The person hooking himself up illegally or adding a second outlet usually does not do high quality work. Often this work creates impedance mismatches or breaks in shielding, causing signal leakage.

- A/B switches. Incorrectly installed or poorly isolated A/B switches can route all or part of the cable drop's signal to the subscriber's antenna, creating a directional "super leak" (Figure 2).

- Aerial drops. Aerial drops which are allowed to whip in the wind can develop cracks or breaks in the foil shield. Such shield breaks allow leakage to occur.

- Staples in drop. Staples that penetrate the shield reduce the RF integrity of the cable and create leakage problems.

- VCR shielding. Some consumer electronic devices are not effectively shielded or isolated. They allow ingress

A/B Switches

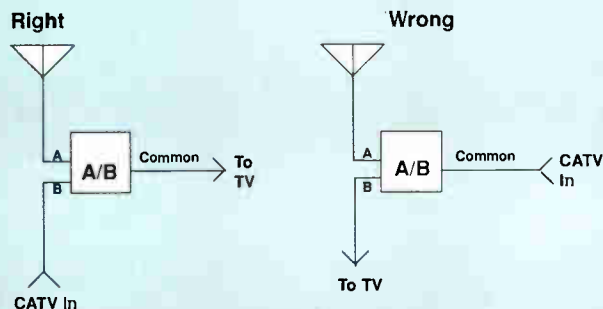

Figure 2

FM Hook Up

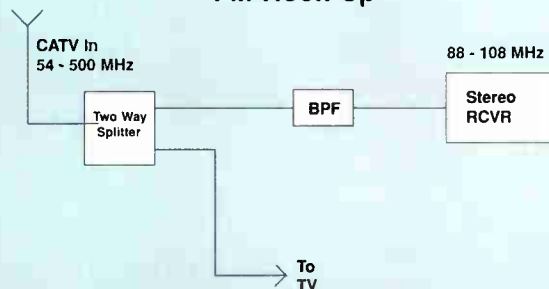

Figure 3

# Pico Macom Set The Standard... Before The Standard Was Set!



## Meet the November 1st FCC requirements with Pico Macom's patented AB-2—the #1 selling switch in the CATV industry!

Pico Macom was first in setting the highest standards for A/B switches through an exclusive patented design and heavy duty construction. With sales of over a million switches each year, the AB-2 continues to outsell and outperform the competition.

Every switch we manufacture exceeds the FCC technical requirements (GEN. Docket 87-309) with high isolation and an internal diecast housing for superior RF shielding.

Offer your subscribers the most reliable A/B switch on the market. You'll be confident Pico Macom exceeds the new standards — because we always did!

The AB-2 and the AB-2LK (parental control locking version) are available through leading CATV distributors. For the distributor nearest you call toll free 1-800-421-6511.

U.S. PATENT NO. 3940584

Reader Service Number 54



**PICO MACOM, INC.**  
12500 Foothill Boulevard  
Lakeview Terrace, CA 91342  
(818) 897-0028  
Fax # (818) 899-1165

Inside the U.S.  
CALL TOLL FREE  
**1-800-421-6511**



## Introducing Syndex peace of mind... it's all in the cards.

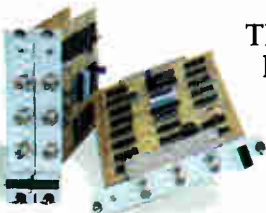

The Trilithic 7RS is a modular headend reconfiguration system. With it you gain total control and unmatched programming flexibility—Syndex or no Syndex.

**Modular. Flexible. Expandable.** Trilithic offers you a broad range of modular, interchangeable switch cards. You have the flexibility to tailor the 7RS functions to suit your needs and expand it whenever necessary. Much like a headend, the variety of configurations is almost endless.

**Technology Working For You.** The technology used in the 7RS puts total control at your fingertips. It can be operated manually or through any IBM compatible computer under control of scheduling software or by keyboard command for general reconfiguration.



### Hardware options and Software functions

Our vast array of cards execute the following switching and other functions:

- Stereo Audio
- Baseband
- RF
- Contact Closures
- Satellite Receiver Frequency Tuning
- And much more

Our switching products interface with "CASEY"\* software which offers features such as:

- Scheduling
- Contract information
- Trilithic switch interface
- Management reports
- Program data base interface
- Plus a lot more

\* Trilithic is an authorized stocking distributor for "CASEY" software.

"CASEY" is a trade name of Telecommunication Products Corp.

Reader Service Number 55

For more information, about the Syndex solution, call or write:  
Trilithic ■ 3169 N. Shadeland Avenue ■ Indianapolis, Indiana 46226 ■ 317-545-4196  
800-344-2412 Outside Indiana ■ FAX: (317) 547-2496 ■ TELEX 244-334 (RCA)



## COMPLIANCE



direct pickup problems) and egress (signal leakage) to occur.

- FM hook-ups. In addition to possible shielding inadequacies, the FM receiver may provide a match only in the 88 MHz to 108 MHz FM band.

Frequencies outside that band will be reflected and may radiate. The use of an FM band-pass filter will significantly reduce this problem (Figure 3).

### Converting dBmV to $\mu\text{V/m}$

Signal leakage is measured in  $\mu\text{V/m}$  (microvolts per meter). Since signal level meters measure level in dBmV, it is necessary to convert from one set of units to another. The formula for  $\mu\text{V/m}$  is listed below:

$$E_f = 0.021 \times E \times F$$

where  $E_f$  = Field intensity in  $\mu\text{V/m}$ ,

$E$  = Field strength in  $\mu\text{V}$ , and

$F$  = frequency in MHz.

This formula requires that we know the received signal voltage in microvolts ( $\mu\text{V}$ ) so we must convert from dBmV to microvolts using the following formulas:

$$\text{dBmV} = 20 \times \text{LOG } E / 1000$$

and solving for  $E$ ,

$$E = (10^{(\text{dBmV} / 20)}) \times 1000$$

where  $E$  = voltage in microvolts across a 75 ohm impedance load.

For example: What would a  $20 \mu\text{V/m}$  leak at 133.2625 MHz correlate to in dBmV?

$$E_f = 0.021 \times E \times F$$

$$20 \mu\text{V/m} = 0.021 \times E \times 133.2625 \text{ MHz}$$

solving for  $E$ :

$$20 / (0.021 \times 133.2625) = E$$

$$E = 20 / 2.7985$$

$$= 7.1467 \mu\text{V}$$

converting to dBmV:

$$\text{dBmV} = 20 \times \text{LOG } (0.0071467 \text{ mV})$$

$$= -42.92 \text{ dBmV}$$

Therefore a  $20 \mu\text{V/m}$  leak at Channel C will measure -42.92 dBmV on a signal level meter when connected to a half-wave antenna (neglecting cable loss and preamplifier gain). A chart of frequency dependent  $\mu\text{V/m}$  to dBmV conversions, developed by Ron Hranac of Jones Intercable was recently published in *Installer Technician* magazine.

### Equipment calibration

Now that we can convert from  $\mu\text{V/m}$

to dBmV, we can perform signal leakage measurements using either measurement unit. The next step is to calibrate the measuring or monitoring equipment. Usually the equipment manufacturer will include a calibration procedure in the operation instructions and, as the saying goes, "when all else fails, read the manual."

One common method of calibration is to inject a signal from a signal generator into the signal leakage detector's antenna port (Figure 4). In the previous calculation we determined that  $20 \mu\text{V/m}$  at channel C is -43 dBmV, which also correlates to -92 dBm. We can inject a signal at that level into the signal leakage detector to either establish a threshold or calibrate the leakage detector's meter, if it has one. Be aware that some signal leakage detectors have a voltage present on the antenna port which is used to drive a preamplifier.

Check for this voltage before connecting the signal generator. If your detector uses an external preamplifier, you must take its gain into consideration in your calculation of the signal level to be inserted into the detector. For example, if the unit has a 16 dB

tor level, calculate the free space path loss from the formula below:

$$\text{Free Space Path Loss} = 36.6 + 20 \text{ LOG } F + 20 \text{ LOG } D$$

## Calibration Using a Signal Generator

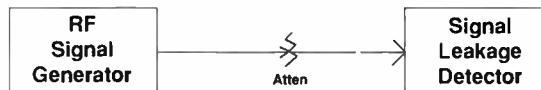

Direct Connection Method

Figure 4

where  $F$  = Freq in MHz,  $D$  = Distance in miles

For more repeatability, the spacing between the source and the detector should be greater than 5 wavelengths, which would be 11 meters or approximately 33 feet at channel C.

If we place the "leak" at 40 feet from the detector, the free space path loss would equal:  $[36.6 + 20 * \text{LOG } 133.2625 + 20 * \text{LOG } (40/5280)]$  or  $36.6 + 42.5 + (-42.4) = 36.7 \text{ dB}$ . Note the relationship between distance and path loss. If the distance to the leak is doubled, the path loss is increased by 6 dB and therefore the input voltage is reduced by one-half (6 dB).

The path loss calculation is based upon loss in free space, a condition that we really do not have. Objects in or near the path will affect the signal by causing reflections which will add

### Generating A Known Field

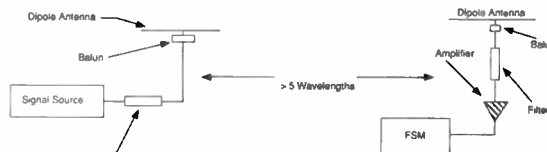

Figure 5

preamplifier, a signal injected directly into the detector (bypassing the external preamp) would then be -27 dBmV (-43 dBmV + 16 dB gain).

A third calibration method is to generate a leak of a known  $20 \mu\text{V/m}$  field (Figure 5). This "leak" can be a dipole antenna connected to a signal generator or your leakage detector transmitter so that your technicians can park their trucks at a fixed distance to calibrate their detectors. This "leak" should only be turned on during calibration periods to avoid interfering with off-air services.

We've already determined that the calculated level for  $20 \mu\text{V/m}$  at channel C is -43 dBmV. To determine an approximation of the required genera-

tor level, calculate the free space path loss from the formula below:  $[36.6 + 20 * \text{LOG } 133.2625 + 20 * \text{LOG } (40/5280)]$  or  $36.6 + 42.5 + (-42.4) = 36.7 \text{ dB}$ . Note the relationship between distance and path loss. If the distance to the leak is doubled, the path loss is increased by 6 dB and therefore the input voltage is reduced by one-half (6 dB). The path loss calculation is based upon loss in free space, a condition that we really do not have. Objects in or near the path will affect the signal by causing reflections which will add either in phase or out of phase, affecting the resultant received signal. Both the "leak" antenna and detector antenna should be at least 10 feet above ground level and as free of reflecting objects as possible.

With a calibrated signal level meter or spectrum analyzer at the receive antenna, the "leak generator" level should be adjusted so that  $20 \mu\text{V/m}$  or equivalent is measured at the detector.

The received field strength will vary slightly with local conditions and the transmitter level may require slight adjustment from time to time to maintain the same field intensity. For a backyard easement situation, the detector can be calibrated for a  $2.5 \mu\text{V/m}$  leak to simulate an 80 foot distance. Eighty feet would be effectively doubling the distance 3 times—10 feet to 20 feet, 20 feet to 40 feet, and 40 feet to 80 feet—which reduces the received signal by half for each doubling— $20 \mu\text{V/m}$  to  $10 \mu\text{V/m}$ ,  $10 \mu\text{V/m}$  to  $5 \mu\text{V/m}$ ,



and 5  $\mu\text{V}/\text{m}$  to 2.5  $\mu\text{V}/\text{m}$  (refer to the 6 dB relationship mentioned above). Corrections can be calculated for whatever distance is appropriate for your system.

**Antennas**

Now comes the fun part—finding the leaks. First of all, the FCC rules and regulations specify that for signal measurement, a half-wave dipole is to be used. For monitoring, you are free to use any antenna that can be correlated to a dipole.

The dipole has a very broad peak at right angles to its elements in both directions (Figure 6). The peak will tell you the level of the leak, but since the peak is so broad, it is sometimes difficult to find the leak by looking for a peak on your meter. Also due to the bi-directional nature of the antenna, you don't know if the leak is in front or behind you. A dipole antenna has a 75 ohm balanced impedance which must be matched to an unbalanced 75 ohm coaxial cable with a 1:1 balun. The matching transformer used at the TV set is a 4:1 balun (300 ohm balanced to 75 unbalanced) so it cannot be used in this application if accurate measurements are desired. My suggestion is to stay with a commercially manufactured dipole antenna that has the necessary matching transformer.

The dipole is one half wavelength long and fed in the center (one-half wavelength in meters =  $(300 / \text{Freq}) / 2$ ). To convert from meters to inches, multiply the result by 39.37 or use the English units version of the formula:  $493 / \text{Freq} = \text{half wavelength in feet}$ .

See Figure 7 for a chart of dipole length vs. frequency.

Rather than using the broad peak signal to locate a signal leakage source, a more accurate approach is to use the 90 degree null (off the end of the half-wave dipole element) where the received signal is at its lowest level. Unlike the peak, the null is very sharp and therefore, by using the null, one can pinpoint the leakage source more precisely. The null will still be bi-directional, so you must determine if the leak

is in front or behind you. The null may be much less than 20  $\mu\text{V}/\text{m}$  in signal strength. A preamplifier may be necessary to obtain enough signal level to overcome the noise floor of the signal leakage detector.

A yagi beam antenna provides 3 dB to 9 dB of gain for locating lower level leaks or locating leaks from a greater distance (Figure 8). It has a "front to back ratio" which means it has a strong peak in front of the antenna and a lower level peak in back (Figure 9). This means you can more easily determine the bearing to your leak. The peak is still relatively broad but as you approach the leak, you can revert back

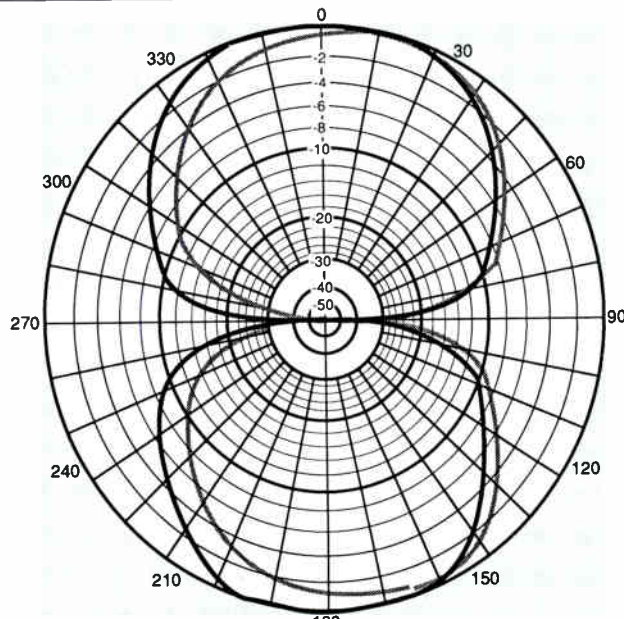

Figure 6

to the null method. The null will be bi-directional, but you've already established the rough bearing with the yagi's peak.

Yagi antennas are readily available for the 144 MHz to 148 MHz and 220 MHz to 225 MHz amateur bands but antennas in the 108 MHz to 137 MHz band may require custom manufacturing. Yagi antennas designed for the amateur bands typically are 50 ohm impedance. If accurate measurements are desired, which probably would not be the case since the FCC requires a dipole antenna for CLI measurements, a 50 ohm to 75 ohm matching transformer would be required. For relative

**The Most Maneuverable**

**Choose the Most Maneuverable Line Laying Machine on the Market. The Line-Ward L-2. Don't Settle For Less.**

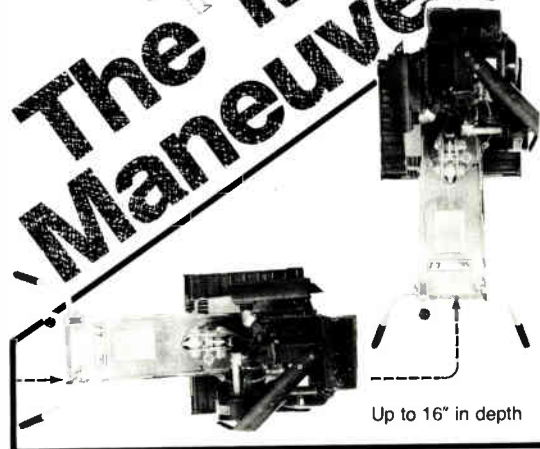

Up to 16" in depth

■ You Can Literally Turn On A Dime

Our unique, patented design centers the 800 lb. total weight *directly* over the 4-wheel drive with the blade in the *exact* center of the machine.

■ Smallest Turning Radius Of Any Machine

Electric Start Optional

Fast Parts Delivery & Service

■ With Your Line-Ward, You Can Actually Make Right Angle Turns

Call For A Free On-Site Demonstration Or, Write For Our Free Color Brochure



Line-Ward Corp.  
157 Seneca Creek Road  
Buffalo, New York 14224  
(716) 675-7373

**COMPLIANCE**



measurements and leakage location, the mismatch should not present a problem.

Once you are close to the leak, it may be necessary to use a near field detector. The near field detector is a "lossy" antenna that is designed to be used to approach the leak within inches. This antenna attenuates strong signals so that your leakage detector is not driven into saturation as you approach the leak. To use the near field detector, simply position it a few inches from the cable plant and move the detector parallel to the plant until the maximum signal is achieved.

Near field detectors are available commercially for some vendor's equipment or a loop type antenna can be configured from a piece of drop cable in an emergency. Again, beware of powering on your leakage detector's antenna port when using an antenna other than the ones recommended by the manufacturer.

**Standing waves**

As you approach the leak you may notice peaks and valleys in the signal strength measured on the leakage detector. These are due to the standing

**Half-wave Dipole Dimensions**

Frequency (MHz)	Dipole Length (end to end) (inches)
108.0000	54.78
109.2750	54.14
115.2750	51.32
121.2625	48.79
127.2625	46.49
133.2625	44.39
139.2500	42.48
145.2500	40.73
223.2500	26.50
229.2625	25.80
235.2625	25.15
241.2625	24.52
247.2625	23.93
253.2625	23.36
259.2625	22.82
265.2625	22.30
271.2625	21.81
277.2625	21.34
283.2625	20.89
289.2625	20.45
295.2625	20.04

Figure 7

waves set up by the leak. The standing waves propagate up and down the cable plant's shield and create minor signal peaks at multiples of the quarter wavelength of the signal being measured. These peaks may appear as separate leaks and often when you fix a strong leak, you may find that smaller leaks in the immediate area disappear. Since the quarter wavelength is inversely proportional to the frequency, these peaks will be closer together as the monitored frequency is increased.

**Miscellaneous**

Leakage level is affected by various factors: humidity, wind speed, tem-

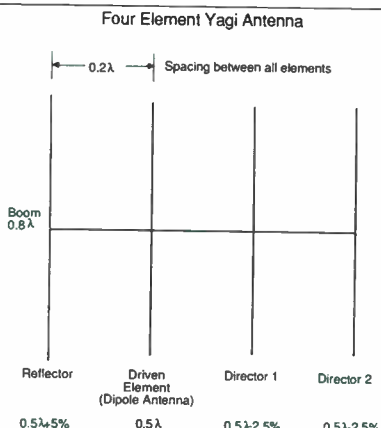

Figure 8

perature and frequency. Moisture in the air may improve shielding where the cable is cracked. As the cable swings in the breeze on a windy day the level of leaks may rise and fall. Changing temperatures cause the cable to expand and contract which can reveal or conceal leaks. When the cable has expanded on a warm day a cable break may have better continuity than when the cable is contracted on a cold day, therefore, the leakage may be stronger on a cold day than a warm day. The physical dimensions of a cable break may cause some frequencies to leak while others do not. In a few cases, you may find that you have a strong leak on one frequency but little signal

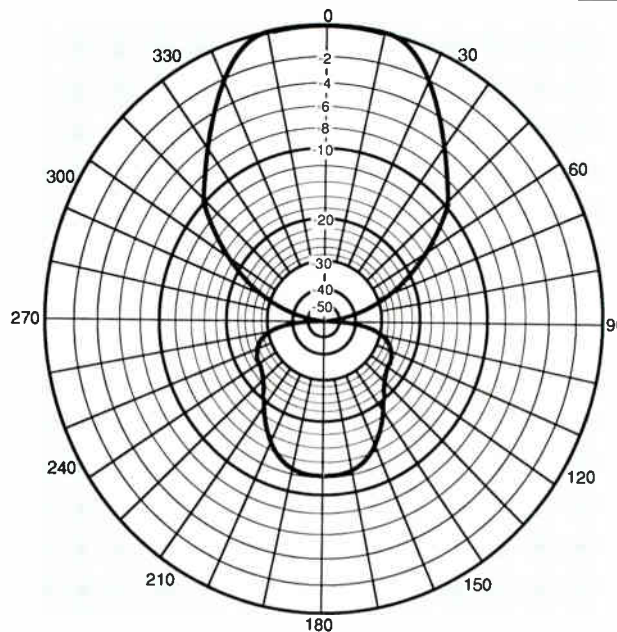

Figure 9

measurable on other frequencies.

Usually, signal leakage is a two way street—cable signals leak out and off-air signals leak in. Signal ingress (off-air signals entering the cable and interfering with system signals) will usually generate subscriber complaints much sooner than egress will. Putting significantly viewed channels on local off-air channels and on frequencies used for paging and two-way radio will generate customer complaints when ingress occurs. This policy can be used as a tool, assisting you in keeping your plant tight, in order to minimize the ingress complaints. When you control your ingress problems, you usually control your egress problems.

**Conclusion**

As we've discussed, there are a variety of factors affecting signal leakage and its propagation. The cable system operates in an ever-changing environment and is subject to constant flexing. This flexing will eventually cause leaks to occur. In order to minimize the level and quantity of signal leaks in the system, it is necessary to diligently monitor the plant on an ongoing basis.

The FCC recognizes that you will never have a "leak-free" system—at least not every day of the year. The concern is that you control your system's signal leakage and that you find and correct problems as soon as possible when they do occur. Failure to do so will result in fines and possibly loss of usable spectrum, not only for the

*Continued on page 110*

# We'll Cut To The Core Of Your Underground Problems.



*All Sizes Of Pedestals*

*Cable Fault Locator*

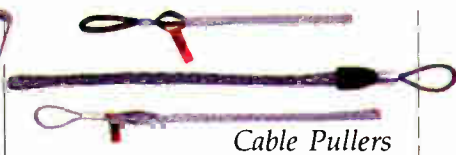

*Cable Pullers*



*Heat Shrink*



*Cable In Conduit*

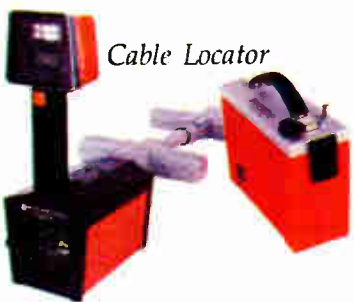

*Cable Locator*

*Direct Burial Splicers*



*Drop Machine*

**Call Us With Your Next Order.**

Reader Service Number 58

**Cable Services Company Inc.**



2113 Marydale Ave. • Williamsport, PA 17701 • 717-323-8518 • 800-233-8452 • In PA: 800-332-8345 • FAX 717-322-5373

# Easier testing with a CATV analyzer—Part I



A portable spectrum analyzer performs CATV tests at the cable terminal box. A portable AC power source provides power for field operations.

This article is the first in a four-part series adapted from Hewlett-Packard Company's CATV Analyzer Measurement Seminar, presented at various local SCTE chapter seminars. Throughout the series, general spectrum analyzer applications are related to the CATV environment, and advantages of the modern spectrum analyzer are demonstrated.

Today's microprocessor-driven spectrum analyzer has increased capability for both general measurements and CATV applications. The CATV analyzer is a modern spectrum analyzer with built-in functions for cable television testing according to the NCTA Recommended Practices for Measurements on Cable Television Systems and the Code of Federal Regulations.

We begin with an overview of the measurement capabilities of the enhanced spectrum analyzer and its basic

By Mary Jane Pahls, Hewlett-Packard Co., Signal Analysis Division

operation. In upcoming months we will cover:

- controls, functions and measurement techniques
- the microwave spectrum analyzer in CATV testing
- amplitude measurements in the CATV environment
- specialized CATV functions and tests.

### Why a spectrum analyzer?

Modern, swept-tuned spectrum analyzers have become widely accepted as tools for testing and maintaining cable television systems.

Originally built during World War II to study the oscillators and modulators used in radar systems, spectrum analyzers have grown immensely in capability and variety. Today, they provide measurement data on signals ranging in frequency from subhertz to hundreds of gigahertz. Sophisticated digital functions such as trace markers and the fast Fourier transform (FFT) have been added. Portable spectrum analyzers are now popular for field-service uses such as CATV testing. In the cable environment, the analyzer is used for headend testing, trunk maintenance, and CARS-band measurements.

The spectrum analyzer is a type of signal analyzer, an instrument that extracts information from electronic signals. While another familiar signal analyzer, the oscilloscope, displays signal amplitude vs. time, the spectrum analyzer displays signal amplitude vs. frequency and displays individual signals by sweeping its tuned input over a wide frequency range. As we see in Figure 1, what appears to be a single

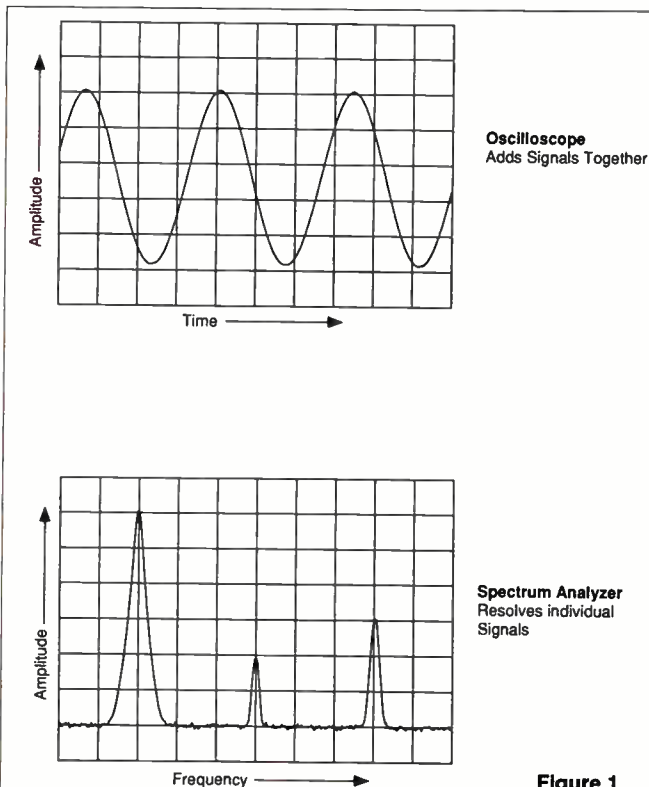

Figure 1

sinusoid on the display of an oscilloscope is revealed by the spectrum analyzer to be a combination of three sinusoids—the fundamental and two harmonics. Thus as Figure 2 shows, the spectrum analyzer disassembles complex waveforms into individual frequency components, displaying the amplitude level and frequency of each, even those small components that may be obscured by much larger amplitude signals on an oscilloscope CRT.

For the cable technician, this means that he or she can examine individually the video carrier, modulation sidebands, and audio carrier in a television channel, or look at all the carriers in the system at one time. In fact, many of the standard measurement capabilities of the spectrum analyzer are useful in CATV testing. A technician can:

- view the individual channels of a cable system
- separate a channel into visual and audio carriers
- analyze all cable bands and the satellite downconverted band
- measure signal frequency and amplitude of the visual and aural carriers
- measure AM modulation depth on the visual carrier and peak FM deviation on the aural carrier

- observe co-channel interference and other spurious signals within a channel

- search for ingress and egress in the CATV system and use the analyzer to measure cumulative leakage index (CLI).

The CATV analyzer further enhances the standard measurement capabilities of the spectrum analyzer with a number of special functions. Some of these make use of sophisticated computer algorithms such as the FFT to accurately make measurements such as power-line hum and cross modulation. Other functions transform into one-button measurements tests that,

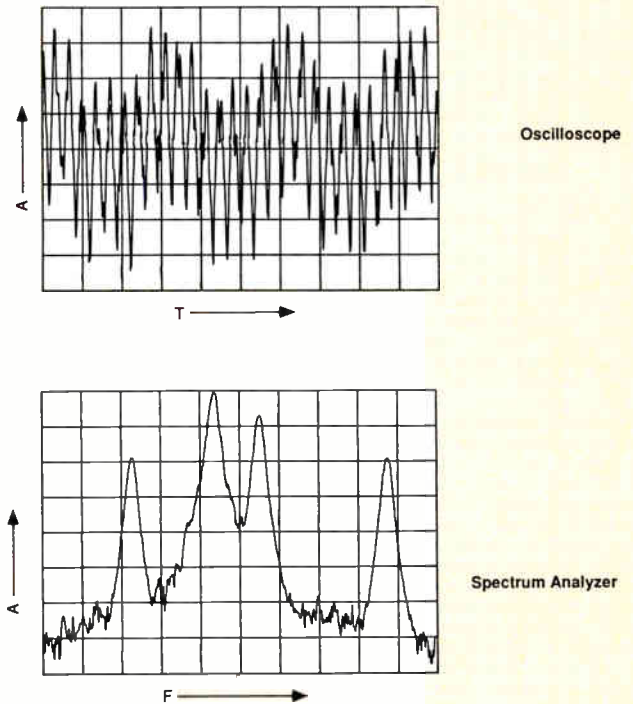

The Spectrum Analyzer Displays Frequency Components of Complex Waveforms

Figure 2

## Your #1 Source For CATV Equipment & Service

### We Buy, Rebuild & Sell

- Large Volume is our Specialty!
- Excess Inventory
- Refurbished Line Equipment
- Complete Bill of Materials
- Fast Delivery!

Guaranteed To Meet Factory Specs!  
120 Day Parts and Labor Unconditional Warranty

Outside California  
800/227-1200

Inside California  
800/223-3152

415/651-4331  
FAX 415/651-8545



2211 Warm Springs Court, Fremont CA 94539

Reader Service Number 60

## .2-1000 MHz In One Sweep! AVCOM's New PSA-65A Portable Spectrum Analyzer

The newest in the line of rugged spectrum analyzers from AVCOM offers amazing performance for only \$2,675.

AVCOM'S new PSA-65A is the first low cost general purpose portable spectrum analyzer that's loaded with features. It's small, accurate, battery operated, has a wide frequency coverage - a must for every technician's bench. Great for field use too.

The PSA-65A covers frequencies thru 1000 MHz in one sweep with a sensitivity greater than -95 dBm at narrow spans. The PSA-65A is ideally suited for 2-way radio, cellular, cable, LAN, surveillance, educational, production and R&D work. Options include frequency extenders to enable the PSA-65A to be used at SATCOM and higher frequencies, audio demod for monitoring, log periodic antennas, 10 KHz filter for .2 MHz/DIV range, carrying case (AVSAC), and more.

For more information, write, FAX or phone.

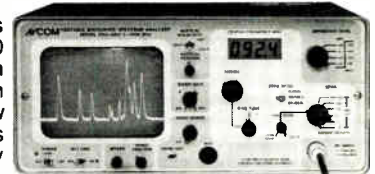

# AVCOM

BRINGING HIGH  
TECHNOLOGY  
DOWN TO EARTH

500 SOUTHLAKE BOULEVARD  
RICHMOND, VIRGINIA 23236; 804-794-2500  
FAX: 804-794-8284, TLX: 701-545

Reader Service Number 59

09:38:48 30 AUG 1989  
 CHANNEL 7 (STD)  
 REF 21.1 dBmV ATTEN 10 dB

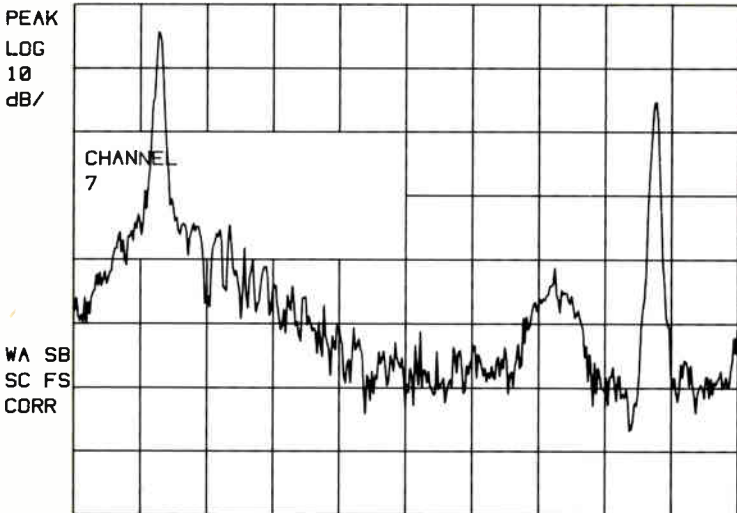

CENTER 177.500 MHz  
 RES BW 30 kHz  
 VBW 30 kHz  
 SWP 20 msec

Figure 3a

CATV  
 CHANNEL SELECT

LISTEN ON  
 MIN HOLD ON  
 BEAT MEAS  
 CARRIER LEVEL

More  
 1 of 3

09:51:45 30 AUG 1989  
 CHANNEL 7 (STD)  
 REF 25.5 dBmV ATTEN 10 dB

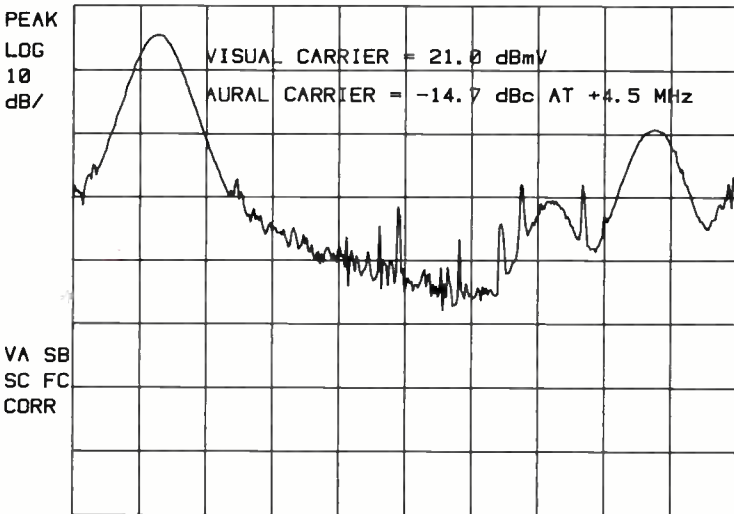

CENTER 177.500 MHz  
 #RES BW 300 kHz  
 VBW 100 kHz  
 #SWP 30 msec

Figure 3b

CATV

RETURN TO CHAN

the vertical plates of the CRT. A sawtooth waveform is applied to the horizontal plates, moving an electron beam across the CRT from left to right. Changes in amplitude move this same beam vertically in its path across the CRT. The result is a display of an amplitude-vs.-time waveform, shown in Figure 4.

In a spectrum analyzer, signals applied to the wideband RF input are converted to an intermediate frequency (IF) through superheterodyning. When the local oscillator (LO) is tuned over its range, different RF signals can be received; that is, the fixed IF is generated from specific combinations of LO and RF frequencies.

As in the oscilloscope, a sawtooth waveform is applied to the horizontal plates in the spectrum analyzer. If the LO frequency is fix-tuned—not being swept—the CRT will display an amplitude-vs.-time waveform like that of the oscilloscope. (This is referred to as “zero span” of the spectrum analyzer.) However, if the LO frequency is swept by the same sawtooth that sweeps the horizontal plates, then a display of amplitude-vs.-frequency results. This is shown in Figure 5.

Making basic measurements with a spectrum analyzer (such as the one in the photo below) is easy, requiring just a few controls. The three most prominent keys control the frequency, span, and amplitude; the other keys provide additional functions and convenience features. Function settings are changed with three data-entry controls: a knob for continuous, analog-like adjustment; step keys for quick, coarse tuning; and number keys for entering specific values. Pressing a key activates its function and displays its current value in the active-function area (mid-screen, left-hand side) as shown in Figure 6. Current settings for the most important functions appear on the CRT screen around its periphery.

The front panel of a modern spectrum analyzer shown in the photo combines “hard” keys that activate menus with “soft” keys to select individual menu functions. The six soft keys are located on the CRT bezel (right-hand side) adjacent to the menu selections that they control. This configuration assigns the most common functions to the hard keys for fast selection and additional levels of functions to the soft keys for measurement flexibility.

The display of the spectrum analyzer can be centered upon a signal or one of its harmonics by pressing the FRE-

if done manually, would require many steps and calculations.

For example, Figures 3a and 3b show a CRT display of a carrier-level measurement on a television signal. Both visual and aural carriers are being modulated as they are displayed (Figure 3a). By pressing the “button” (or key) next to the menu selection CARRIER LEVEL, the analyzer automatically measures the peak-amplitude level of each carrier and reports the results (Figure 3b): visual-carrier level in

dBmV and aural-carrier level in dB relative to the visual carrier. We’ll examine this and other special CATV functions later in this series.

**Basic operation**

Both the oscilloscope and the spectrum analyzer display amplitude changes while an instrument parameter is swept. The oscilloscope sweeps time. Through wideband video amplifiers, the signal amplitude is applied to

# We carry your size.

## CSR-191

controls one VCR for random sequential spot selection.

**Texscan**  
MSI COMSERTER 191

CSR-192 controls two VCR's for random or semi-random access selection.

**Texscan**  
MSI COMSERTER 192

## CSR-294

controls four VCR's for random access selection during two minute breaks. It can insert spots on two satellite channels at mutually exclusive break times.

**Texscan**  
MSI COMSERTER 294

Advertising and engineering managers across the country demand the wide range of capabilities offered by ComSertter. Key benefits are random access spots, full stereo audio, direct spot search, automatic fail-safe modes, broadcast style switching, selectable end-of-break modes, video verification, advanced tape marking, simplified installation, automatic VCR timing adjustments, auxillary inputs, external processor loop, preview outputs, multi-tasking operating system and modular design as well as thorough training and support. Our standards of quality and reliability have resulted in the selection of ComSertter being the commercial insertion equipment choice of 18 of the top 20 MSO's.

We're focusing on your future.

**Texscan MSI**

124 North Charles Lindbergh Drive, Salt Lake City, Utah 84116 / 800-367-6011 or 801-359-0077

Reader Service Number 61

GENERAL OSCILLOSCOPE

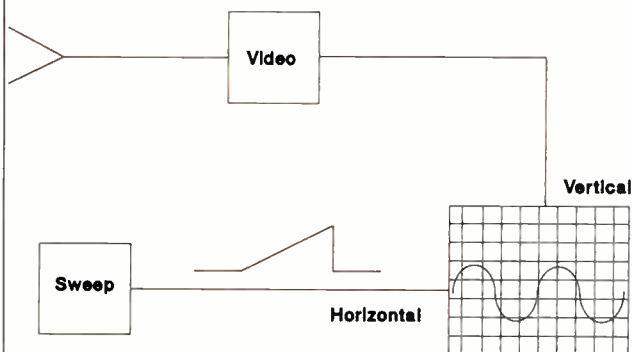

Figure 4

GENERAL SWEPT-TUNED SPECTRUM ANALYZER

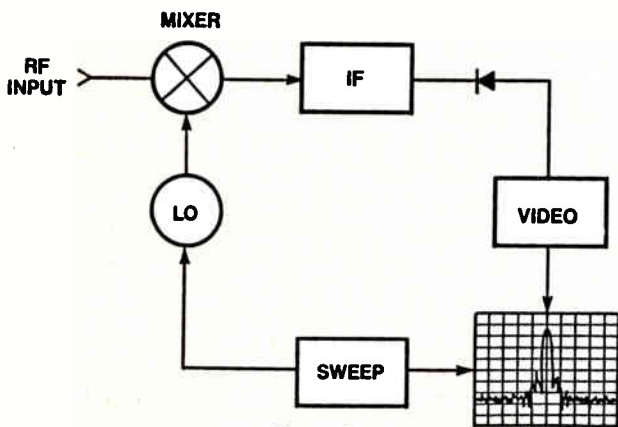

Figure 5

control knob. The value of the centered frequency appears in the active function area.

The frequency span is a window size for viewing signals. This range of frequencies appears between the extreme left and extreme right graticule lines of the display. After a signal has been positioned at the center frequency line, the frequency span can be narrowed to get more detail and eliminate other signals from view. Span per division is calculated by dividing the frequency-span setting by the number of horizontal divisions. This information can be used to determine the frequencies of signals not at the center line.

Placing the signal peak at the reference level, or top of the horizontal line of the display, is one way to measure the amplitude level of that signal. The AMPLITUDE hard key

division) and measuring its distance below the reference level.

One of the most useful features of the modern spectrum analyzer is the trace marker. Markers save time and reduce errors in measuring signals. A readout appears on the display of the frequency and amplitude of any signal upon which a marker has been placed. This eliminates the need to center the signal



Front panel photo of a CATV analyzer.

and move it to the reference level. One key press places a marker on the displayed signal with the highest amplitude; the control knob and keys in the marker menu move the marker to other locations. Figure 7 shows how markers can measure the frequency and amplitude differences between two signals.

Summary

We've now considered some of the measurement capabilities of the modern spectrum analyzer that make it a useful instrument upon which to base a CATV analyzer. We've also looked at the basic operation of such an analyzer. In Part II of this series, we will discuss the analyzer controls and functions that can be used for effective testing in the cable television environment. ■

QUENCY hard key and entering the desired frequency value. The signal then appears in the middle of the CRT. Also, the spectrum can be moved around the display using the step keys or

changes the values of the reference level and thus moves the displayed signals up or down. The amplitude of a signal can also be found by knowing the vertical scale calibration (dB/

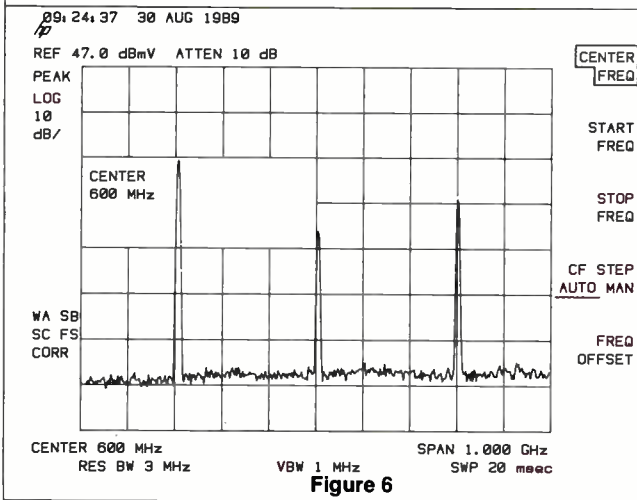

Figure 6

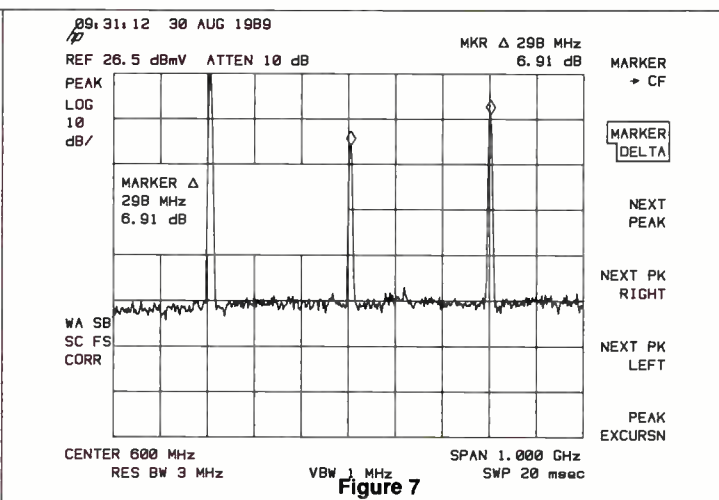
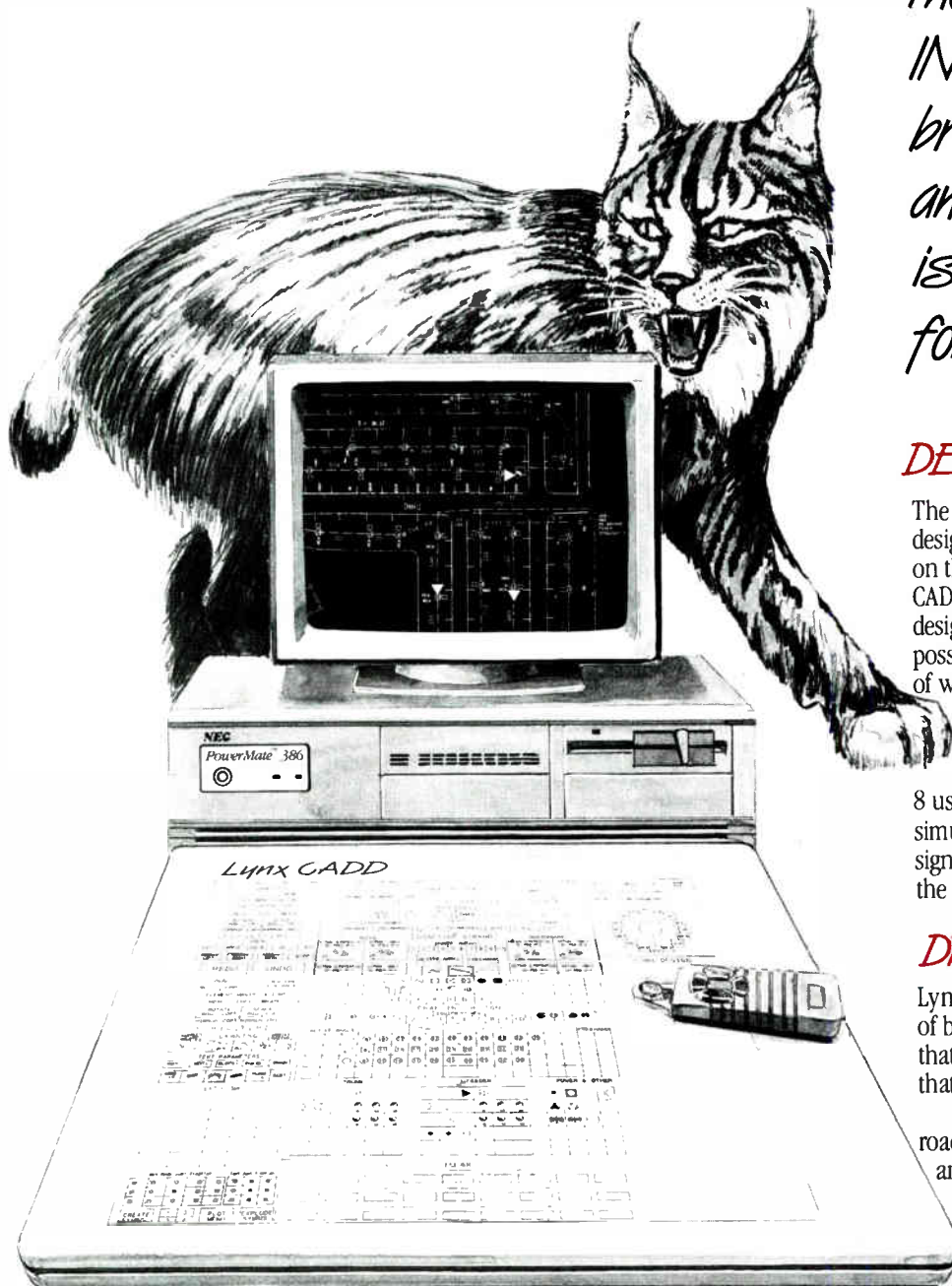

Figure 7



# Run with the Lynx!



Featuring the NEC PowerMate 386.

## A.D.S.

Automated Drawing Systems, Inc.

Reader Service Number 62

The most powerful  
**INTEGRATED**  
broadband design  
and drafting package  
is now available  
for your PC . . .

### DESIGN . . .

The intelligence of Lynx CADD gives the designer the power to calculate design right on the map. Simply specify the area and Lynx CADD automatically calculates the optimum design for you. Or, explore alternate design possibilities simply and quickly for any type of what-if situation.

Detailed Bill of Materials are produced automatically.

With Lynx CADD, up to 8 user-specified frequencies are tracked simultaneously. And it is possible to monitor signal from a subscriber's house back to the headend.

### DRAFTING . . .

Lynx CADD has taken the basic functions of broadband drafting and created features that dramatically increase the number of miles that can be mapped in a day.

For **base** mapping, Lynx CADD has a road command with easy intersection cleaning and a MAP/CUT command which will automatically divide a topo, utility or tax map into the individually desired maps.

For posting **strand**, commands are available for automatic placement of text for footages, house counts, addresses and pole numbers.

If **design** is posted manually, the SCTE standard symbols are included for your use.

Call (404)448-0977 or (800)333-ICAD today for more information on this powerful PC-based system for broadband design and drafting.

3150 Gateway Drive, Suite 700  
Norcross, GA 30071

## WHAT'S AHEAD

# SCTE

**October 11 Wyoming Meeting Group** will conduct a technical seminar. Call Matt Forgas, (307) 324-2286 for details.

**October 12 Chesapeake Chapter** will host a technical seminar on "System Performance" at the Holiday Inn in Columbia, Md. For more info call Tom Gorman, (301) 252-1012.

**October 12 The Ohio Valley Chapter** will conduct a technical seminar at the Park Hotel in Columbus, Ohio. The topic will be "CLI" with Robert V.C. Dickenson of Dovetail Communications, Brian James of NCTA, John Wong of the FCC, Ted Hartson with Post-Newsweek and Bob Saunders of Sammons Communications. For info call Bill Ricker, (614) 236-0523.

**October 14 Rocky**

**Mountain Chapter** will sponsor a technical seminar on BCT/E Category I, "Signal Processing Centers." For additional info call Rikki Lee, (303) 792-0023.

**October 18-19 Florida Chapter**, both the South Florida Group and First Coast Group, will conduct technical seminars. Call Denise Turner, (813) 626-7115 for details.

**October 18-19 Heart of America Chapter** will present a technical seminar on Oct. 18 in conjunction with the Mid-America Cable TV Associations annual meeting. BCT/E examinations will be administered on the 19th of Oct. in categories II, III and IV. For info call Wayne Hall, (816) 942-3715.

**October 20 Miss/Lou Chapter** will host a technical seminar on

"Theory of Distribution" with General Instrument/Jerrold Division and "Batteries" presented by Douglas Battery Manufacturing Co. and Exide Corp. at the Seaview Resort in Biloxi, Miss. Call Mike Latham, (601) 226-2886 for more details.

**October 21 Razorback Chapter** will conduct an "Installer Seminar" at the Days Inn in Little Rock, Ark. For more info call Jim Dickerson, (501) 777-4684.

**October 26 Wheat State Meeting Group** will sponsor a technical seminar at the Canterbury Inn in Wichita, Kan. The topic will be BCT/E Category IV, "Distribution Systems" with Ralph Haimowitz, SCTE director of chapter development and training. For details call Mark Wilson, (316) 262-4270.

## MAGNAVOX

CATV SYSTEMS CO.

A DIVISION OF NORTH AMERICAN PHILIPS CORPORATION  
100 FAIRGROUNDS DR., MANHUS, NY 13104

The Magnavox CATV Systems mobile training center is a fully-equipped laboratory on wheels for cable training. The three-day seminars combine instruction in theory and practical hands-on training, using gear and test equipment common

throughout the industry. The fee is \$300.

**October 2-4 Magnavox Mobile Training** will be held in Atlanta, Ga. Call Amy Costello Haube, (800) 522-7464 to register, or for additional info.

**October 11-13 Magnavox Mobile Training** will be

held in Raleigh, N.C. Call Amy Costello Haube, (800) 522-7464 to register, or for additional info.

**October 24-26 Magnavox Mobile Training** will be held in Cherry Hill, N.J. Call Amy Costello Haube, (800) 522-7464 to register, or for additional info.

## C-COR<sup>®</sup>

ELECTRONICS INC

C-COR Electronics "state of the art" seminars are three-day events designed to instruct relatively new technicians in basic theory, installation and maintenance of cable TV systems. Attendance is

limited to a maximum of three persons from one system. The fee is \$195.

**October 17-19 C-COR Electronics Seminar** will be held in Boston, Mass. Call Teresa Harshbarger, (800) 233-2267, ext. 326 to regis-

ter or for info.

**November 14-16 C-COR Electronics Seminar** will be held in Phoenix, Ariz. Call Teresa Harshbarger, (800) 233-2267, ext. 326 to register or for additional info.

## Et cetera

**October 18-20 Kessler Marketing Intelligence** will sponsor a conference at the Sheraton-Islander Inn, Newport, R.I. The theme of the conference is "Fiber optics Moves Toward the Global Village" with speakers from France, the Federal Republic of Germany, Japan and the

United Kingdom. For additional info call (401) 849-6771.

**October 23-26 Siecor Corp.** will conduct a technical course on "Fiber Optic Installation and Splicing for Cable TV Applications" at Siecor's training facility in Hickory, N.C. Call (800) 634-9064

for more information.

**October 30-November 3 Information Gatekeepers Inc.** will host the Broadband '89 FOC/LAN, "Thirteenth Fiber Optics and LAN Exposition" at the Civic Auditorium in San Francisco, Calif. For details call (800) 323-1008 or in Mass., (617) 734-8562.

Over Thirty Years of  
**SERVICE,**  
**RELIABILITY**  
*and*  
**INNOVATION...**

- the First 550MHz Apartment House Amplifier
- the First 700MHz Line Passives

**NOW..** the **FIRST**  
**650MHz**  
**DROP AMPLIFIER**

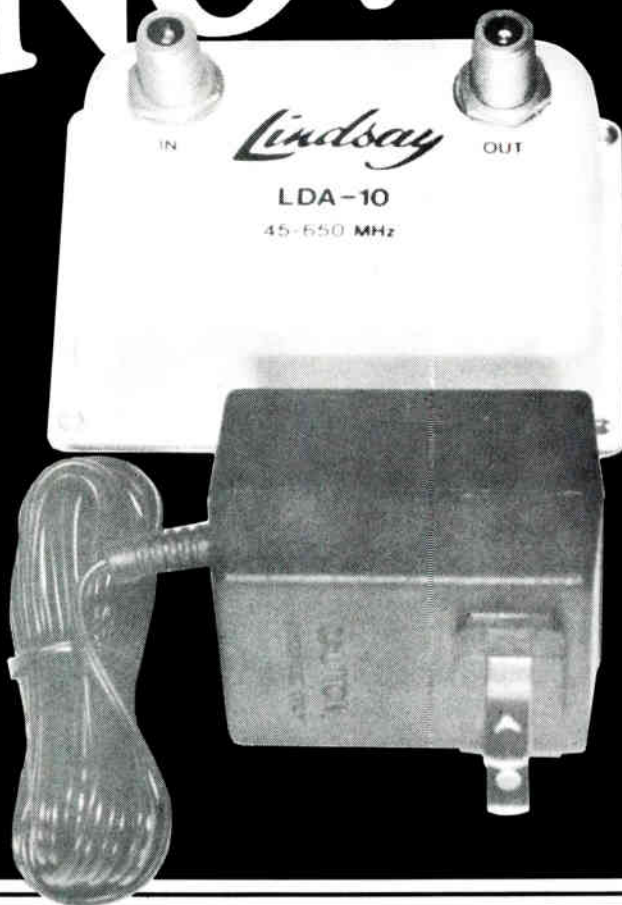

Frequency	45-650MHz
Gain	10dB
Noise Figure	4.5dB
CTB	-65dB

SP and UL Approved

*Lindsay*...Your Full Line  
 CATV Manufacturer ...  
 Actives at 550MHz,  
 Passives at 700MHz,  
 Apartment House Amplifiers and  
 Ganged Apartment Taps,  
 with a full line of  
 CATV Communication Antennas.

*Lindsay*

PA: TONER CABLE EQUIPMENT  
 FL: INTERSTATE CABLE ENTERPRISES  
 PA: JIM MORTON & ASSOCIATES

215-675-2053  
 800-245-4423  
 717-243-4653

MN: GRUNWALD, BURNS & ASSOCIATES  
 CO: MEGA HERTZ  
 CA: WESTERN CATV DISTRIBUTORS INC.

218-739-3961  
 303-779-1717  
 213-539-8030

**LINDSAY SPECIALTY PRODUCTS** 1248 Clairmont Rd, Suite 3D-231, Decatur, Georgia, U.S.A. 30030  
 Telephone: 404-633-2867 Fax: 404-634-1515 Head Office: 705-324-2196

# Technical agenda set

A preliminary agenda for the technical portion of the Western Cable Show in Anaheim in December has been released. Sessions on fiber optics, advanced television, signal leakage and customer satisfaction are included with panels on regulatory issues, the consumer electronics interface and systems of the future.

Here is an overview of what will be presented at the show:

**FCC/Washington update.** An overview of legal, regulatory and political issues affecting the cable technical community.

**Signal leakage.** Experiences of operators in various types of systems will be related. Comparisons of methods for calculating CLI and a comparison of flyovers and ground-based data collection will be made.

**Consumer electronics interface.** Early experiences with MultiPort equipment, status of off-premise equipment development and in-home wiring proposals (SmartHouse, Homebus, etc.) will be the focus.

**Customer satisfaction.** Highlights include reducing service calls through training and tracking; and solving technical problems at their sources.

**Fiber optics.** Something for everyone: New developments, new architectures, new components, economic analysis, design rules and installation practices.

**HDTV/EDTV.** Progress toward standardization, cable performance issues and subjective testing will be discussed.

**System evolution.** Design implications of 1 GHz bandwidths, new architectures to improve performance and an update of operating performance requirements will be the subjects that finish up the Show.

## New message system to premiere

**Quanta Corp.** will introduce its All Channel Message System (ACM) at the Atlantic City cable television expo in Atlantic City, N.J., on October 2, 1989. ACM is a cable headend control system designed to place a video message on any or all channels simultaneously, either as a stand-alone message, or over the normal video programs. Messages can be the same or different on

each channel. Applications include syndex switching with advisory messages for viewers; a video emergency alert and preparedness system; pay-per-view promotions on affiliate channels; local scores on regional sports channels; and satellite-delivered system specific promotions, ads and bulletins by cable. For info call (801) 974-0992.

**Telecommunications Products Corp.** has announced the fall release of a software package, CASEY (Control Automated Switching Easily Yourself), that remotely controls program switching equipment. The program is designed to control syndex switches in as many as 10 headends or hubs and has almost completely unattended, automatic operation. CASEY is menu-driven and includes on-line help at any screen, a color screen, pop-up windows, flexible parameters and an extensive paper trail. Switch schedules are generated by the TV Host database service, electronically, and can be retrieved via telephone modem. For more info call (717) 267-3939.

**ComNet Company** has announced two new PC software tools for designing CATV and RF LANs. The BSE-Pro™, Release 1.0 and BSE-II™, Release 4.0, is scheduled for release this month. The BSE-Pro features pull-down menus, dialogue boxes and speed keys and an RF cable design program capable of designing major CATV systems or broadband LANs from 1 MHz to 2 GHz. The BSE-II has been transformed from the original Broadband System Engineering program and is a scaled-down version of BSE-Pro. It is intended for limited budgets, occasional designing or smaller applications.

BSE-Pro and BSE-II run on any IBM or compatible PC, although a 286 or greater is recommended along with a 512K RAM, DOS 3.1 or higher and a hard disk. For additional info call (512) 892-2085.

Available from **A.D.S. Inc.** is a fully integrated cable TV design and drafting package for the personal computer. Lynx CADD combines Intergraph's MicroStation drafting with the design capabilities of the customized Lynx Design. Special features enable a user to cut a single large map into any number of smaller, individual base

maps for posting strand and design. Lynx CADD analyzes all pole information in the data base for a given area and places the appropriate design equipment on the map for posting. For more info call (404) 448-0977.

**CableCom Specialists Inc.** has announced the coming availability of an IBM compatible, new Time Programmable software that will offer most of the features of CableCom's TPRAS Syndex Switcher. The software will have remote access to switching via conventional dial-up telephone lines as with the Syndex Switcher. The package is scheduled for release in the early fall. For more info call (704) 687-1101 or (800) 541-3881.

## New amplifiers

Available from **Viewsonics** are three new amplifiers for outdoor/indoor use, all of which exceed 100 dB RFI integrity. The VSA-20-12WS is a splitter/amplifier with 12 outputs, a 6 dB gain per port and is rated at 77 channels. The VSA-10-550-2WZ and VSA-20-550-2WZ are bi-directional amplifiers with passive returns. Gains are 10 dB and 20 dB and power is 110V 60 Hz or 220V 50 Hz. Both come with plug-in adapters which are powered by coaxial cable permitting variable distances for powering. For additional info call (800) 645-7600, in N.Y. call (516) 921-7080.

**AVCOM** has introduced a portable spectrum analyzer, the model PSA-65A. Covering 200 kHz to over 1000 MHz in one sweep, the battery or line

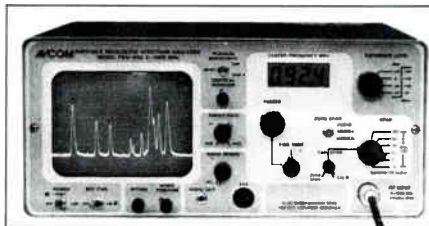

Avcom's PSA-65A spectrum analyzer

operated analyzer has a sensitivity greater than -95 dBm at narrow spans. The digital frequency readout is referenced to a frequency counter for measurements. Options of the PSA-65A include frequency extenders to enable the analyzer to be used at Satcom and higher frequencies, audio demod, 10 kHz resolution crystal filter, log periodic antennas and carrying case. For more info call (804) 794-3600.

**Control Technology** has announced the introduction of the Citation III 16

## 'You may now kiss the bride'

"Until death do you part," is a frightening statement to most people, much less having to perform the marital vows 18 feet up in the air. Needless to say, there are some brave souls out there as evidenced by Duwayne and Patty Hendrickson's wedding on July 1, 1989, in Muskegon, Michigan. Deciding to forego the traditional wedding, the Hendrickson's were married at the top of telephone poles instead of solid ground.

Both the groom and best man climbed the poles with traditional gifts while the bride, maid of honor and minister went up in a bucket truck. The guests, including Patty's five children and Duwayne's one child (all from previous marriages), remained on the ground but had no difficulties in hearing the ceremony, according to Patty Hendrickson. "We wanted to show the kids that they could change if they wanted, that they could have a different kind of wedding and other things as they get older," says the bride.

Duwayne Hendrickson originally conceived the idea based on his long-time experience in the cable industry. Duwayne, who currently works for Lakeshore Cable Contractors, climbs poles nearly every day for strand and cable installs and rebuilds. Since Patty did not oppose the thought, the two forged ahead with the plan on a beautiful, sunny Saturday.

The only "anxious" moment during the ceremony was the exchange of the wedding ring between the best man and groom. The minister asked for "the trick of the evening" and the best man promptly tossed the ring to the groom. Luckily, experience came into play, and the ring was deftly caught. The ceremony continued as scheduled, with a reception on the ground immediately following. "It was different," says Patty Hendrickson. "It was the first time I was ever up on a pole, but I wasn't nervous."

### Bilodeau honored in awards

Robert Bilodeau, chief executive officer of the Three Sixty Corporation, was honored with a Founder's Award by the Pennsylvania Cable Pioneers in ceremonies at State College, Pa. on August 5, 1989. Bilodeau began his cable career in 1951 and has served on committees advising the FCC on tech-

nical matters, the NCTA's engineering committee, two terms as president of the New Jersey Cable Television Association and as president of the Society of Cable Television Engineers. Bilodeau also helped establish the Cable Television Network of New Jersey and serves on C-SPAN's board of directors.

John Spencer has joined Jerrold's operation in the United Kingdom as director of marketing. Spencer most recently served as systems support manager with the AASHA Computer Group in Toronto. Spencer will be responsible for marketing, forecasting, cable system design and support functions for the European operations.



Mary Kazmierczak

Also from Jerrold is the announcement of Mary Kazmierczak as the distributor sales manager for the Jerrold Distribution Systems division. Kazmierczak will be responsible for the operation of the distributor sales force as well as continuing as Jerrold's product manager for the distribution line extender product line. Kazmierczak has been with the company since 1983.

In other news from Jerrold, Doug Light has joined the Jerrold sales group as Southeast regional manager and Jay Curry has joined the sales force as account manager for the Central region. Light comes to Jerrold from RMS Electronics where he served as vice president of sales and marketing. Curry will be responsible for a six state region in the upper Midwest. Randy Jolly has been named to replace Curry as the manager of customer product support.

Edward Kopakowski has joined C-Cor Electronics, Inc. as the national sales manager for the U.S. Data Group. Kopakowski is responsible for sales of all data products, including amplifiers, status monitoring systems, RF modems, and LAN camera control systems. Kopakowski was previously employed by NEC Home Electronics as national sales manager.



Van Costa

Channell Commercial has announced the appointment of Mr. Van Costa to the position of Eastern sales manager. Costa will have

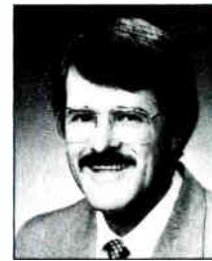

Michael Helton

responsibility for the Eastern United States. Prior to joining Channell, Costa was with Comm/Scope for over eight years.

Also announced by Channell is the appointment of Michael Helton to

the position of Western regional sales manager for the Western United States. Helton was previously with Group W Cable/Teleprompter for 14 years.

John Schonewill has been named national sales manager for Sachs Communications Inc. Shonewill is responsible for all sales activities in the United States. Also named from Sachs is John Montero as inside sales manager and Kay Ahr as branch manager. All three are based in Englewood, Colo.

Pirelli Cable Corp. has announced the appointment of Regis Kubit as commercial manager of installation and engineering services of its Cable Systems division. Kubit was formerly vice president of engineering for Henkels & McCoy.



Bruce Gagnon

Bruce Gagnon has joined Nexus Engineering Corp. as a senior account representative for the U.S. CATV sales team. Gagnon has over six years cable experience and will be responsible for marketing the Nexus product line in the Southeastern United States.

Lasertron has named William Diamond as the European sales manager, responsible for sales activities throughout Europe. Diamond replaces Jeffrey Purchon who will assume the position of North American sales manager located in Burlington, Mass.



Greg Marx

Trilithic Inc. has named Gregory Marx director of sales and marketing for instrument products. Marx was previously regional sales manager for Wavetek RF Products. He will now be responsible for the product service (repair) group. ■

amp 36 volt standby power supply. The Citation III includes features such as built-in self testing, on board diagnostics, high speed switching, built in auxiliary generator input and battery charger. The Citation III also uses Control Technologies patented pulse-width modulated inverter. For more details call (800) 527-1263 or (214) 272-5544 in Texas.

CADCO Inc. has added the option of sub-low channels to its Model 370 demodulator. The factory option will add channels T-7 through T-13 allowing full frequency agility for sub-low

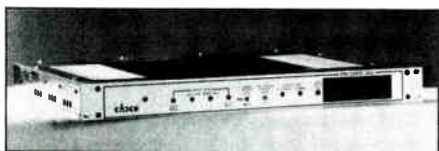

**Cadco's Model 380** channels, standard NTSC off-air channels 2 through 69 and all EIA/NCTA cable channels through 552 MHz. The Model 370 is front panel frequency agile and features synchronous detection, vertical and composite sync output as well as standard demodulator outputs.

Also introduced by CADCO is the

Model 380 stereo encoder. The Model 380 meets FCC OET-60 Broadcast standards for BTSC, has phase-locked aural and video I-F for 4.5 MHz audio/video separations. Features include multiple outputs to interface with any modulator requiring base-band composite stereo audio and 4.5 MHz BTSC subcarrier or 41.25 MHz standard aural subcarrier. For info on either model call (800) 877-2288.

Available from **Jerrold** is an ad-

**Reliable Electric/Utility Products** has announced the release of the T-Safe security enclosure designed to prevent cable theft. The T-Safe is constructed of 16 gauge mill galvanized steel and features a grid mounting plate with mounting holes on 1/2 inch centers. The plate also includes a demarcation plate with F-81 connectors installed. The unit is available in two sizes: 12 by 18 by 8 and 18 by 24 by 8. For details call (312) 455-8010.

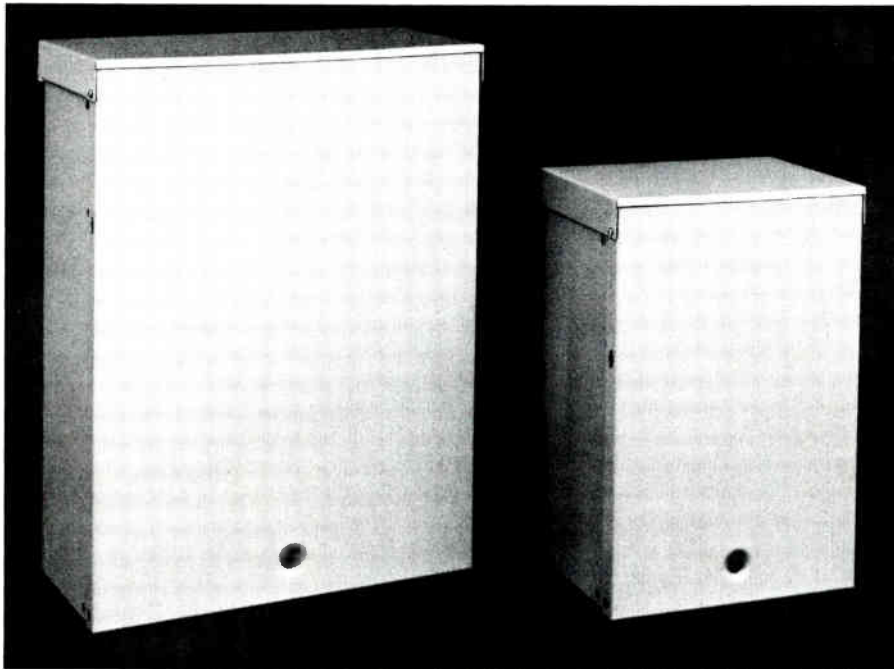

*Reliable Electric's T-Safe Security Enclosures*

dressable control computer, the Model ACC-1000, designed for small- and mid-sized cable systems desiring addressability. The ACC-1000 can carry up to 32 services and 32,000 subscribers and is capable of handling ANI, ARU and CSR pay-per-view ordering. The ACC-1000 uses a Compaq 386 PC with a 40 megabyte hard drive, a 5 1/4 inch floppy drive and operates on DOS software. For additional info call (215) 674-4800.

**Nemal Electronics International** has introduced a series of BNC crimp connectors for use with the **Belden** 8281A (new NEC code) and 88281 (plenum) video cables. The connectors feature silver plated contacts, tarnish resistant bodies and teflon insulation. For more info call (305) 899-0900.

**Blocking interference**

Two paging filters are available from **Microwave Filter Company** to block interference to TV reception because of transmission from paging or amateur radio transmitters. The Model 5KHP-50 high pass filter suppresses interference up to 36 MHz and has a 30 dB stop band. Passband is TV channel 2 MHz to 450 MHz. The Suppression trap PAGE (MHz) comes tuned to customer specified frequency. It prevents interference in the close-in band 41 MHz to 45 MHz. Notch depth is 70 dB and 3 dB bandwidth is plus or minus 1.75 MHz. Both filters have F connectors.

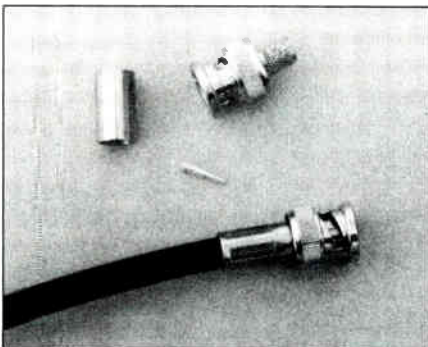

*Nemal's BNC crimp connectors*

U.S. Postal Service  
STATEMENT OF OWNERSHIP, MANAGEMENT AND CIRCULATION  
Required by 39 CFR 3001.0-2

1. TITLE AND ADDRESS OF PUBLICATION  
 TITLE: LED  
 ADDRESS: 600 South Cherry St., Suite 100, Denver, CO 80222

2. NUMBER OF ISSUES PUBLISHED DURING PREVIOUS 12 MONTHS  
 11

3. ANNUAL SUBSCRIPTION PRICE  
 \$18.00

4. FULL NAME AND COMPLETE MAILING ADDRESS OF PUBLISHER  
 Roger Brown, 600 South Cherry St., Suite 100, Denver, CO 80222

5. FULL NAME AND COMPLETE MAILING ADDRESS OF EDITOR  
 Roger Brown, 600 South Cherry St., Suite 100, Denver, CO 80222

6. FULL NAME AND COMPLETE MAILING ADDRESS OF OWNER  
 Roger Brown, 600 South Cherry St., Suite 100, Denver, CO 80222

7. STATEMENT OF CIRCULATION  
 a. Total copies (net press run) 18,014  
 b. Paid circulation 11,880  
 c. Free circulation 6,134  
 d. Total distribution 17,914  
 e. Copies not distributed 624

8. I certify that the statements made by me above are correct and complete.

## IN THE NEWS

Also available from Microwave Filter is the Positrap system to restrict viewing by scrambling sensitive channels in private or public cable systems. The unit is added to the existing system without restructuring the network. The channel is scrambled by connection of an encoder (model EC channel#) after the channel RF modulator. A decoder trap (5KVP-Channel#) at each authorized TV set allows programming to be viewed. For info on either item call (800) 448-1666 or collect (315) 437-3953 N.Y., Hawaii and Alaska residents.

**Ripley Company Inc.** has introduced additional accessories to be used with CST combination core and strip tools. The accessories will allow the CST tool to produce the exact center conductor cut lengths necessary for popular brands of feed thru connectors. The new parts, which can be used with either the CST combination tool ratchet handle or the drill adaptor, consists of a tool extension and strip stop. For info call (203) 635-2200.

A 100 MHz oscilloscope has been announced by **B&K Precision**. The Model 2190 offers a range of high-end features including triple input and six-trace operation. This capability al-



*B&K Precision's Model 2190*

lows three different signals to be observed at two timebase settings. Other features of the Model 2190 include 1 mV per division vertical sensitivity, V-mode for viewing two signals unrelated in frequency, dual time base, alternate sweep function and 200 MHz bandwidth limiter and video-sync separators. For more info call (312) 889-1448.

**Hewlett-Packard** introduced two PC-based spectrum/network analyzers, the 12.8 kHz HP 3566A and the 102.4 kHz HP 3567A. Both programmable analyzers offer built-in time and frequency domain measurements, which can be expanded to 16 simultaneous data-acquisition input channels to reduce overall measurement test time. Specific measurement features include

multichannel power spectrums, waterfall displays, frequency-response functions, auto/cross correlation, transient-time capture, one-third octave with A-weighting, stimulus-response testing and order tracking. For details call (800) 752-0900.

Announced by **R.L. Drake Company** is a commercial earth station receiver with a high level of IF (intermediate frequency) signal processing for professional-grade video signals. The Model ESR2235 mounts in a standard 19-inch rack; has decoder outputs for use with commercial de-



*R.L. Drake's Model ESR2235*

scramblers; block down conversion with Drake's BDC-24 block down converter or LNB; dual signal inputs with automatic or manual polarity changeover for dual feed installations; a 950 MHz to 1450 MHz IF loop-through output; and a SAW filter. For more info call (513) 866-2421.

Available from **Xentek** is a new



# Lemco

the  
tools  
of the  
trade

Call for your free  
catalogue.

**(800) 233-8713**

Reader Service Number 56

**New Product**

## RISER-BOND INSTRUMENTS

### Model 1210

TIME DOMAIN REFLECTOMETER  
CABLE FAULT LOCATOR

- SUPERTWIST LIQUID CRYSTAL DISPLAY
- AUTOMATIC DISTANCE CALCULATION
- WAVEFORM/DATA PRINTER STANDARD
- RECHARGEABLE NICAD BATTERIES STANDARD
- TESTS ALL TYPES OF METALLIC PAIRED CABLE
- LIGHTWEIGHT, COMPACT AND RUGGED PACKAGING
- EASY TO OPERATE

**\$4,395**  
Complete



For more information or to place an order call or write:

**RISER-BOND  
INSTRUMENTS**

505 16th STREET P.O. BOX 188  
AURORA, NEBRASKA 68818  
402-694-5201

Reader Service Number 65

# CLASSIFIEDS

## HELP WANTED

### CONSTRUCTION PERSONNEL

*Your  
Career Picture  
Is Bright In  
CABLE TV*

STATEN ISLAND CABLE is a rapidly expanding operation involving a 700 mile system in Staten Island. Our growing success has created exciting opportunities for construction people. We're seeking individuals who must have extensive experience in CATV aerial and underground construction, and the ability to read and utilize maps. These positions are currently available:

#### CONSTRUCTION SUPERVISOR

High School graduate with the above-mentioned qualifications, plus ability to read and utilize diagrams. Previous supervisory experience a big advantage.

#### CONSTRUCTION CREW

Personnel for these in-house crew positions will be responsible for day-to-day construction extensions and maintenance of plant utility requirements.

We offer an excellent salary based on your experience, plus outstanding benefits package. Send resume and salary history, indicating which of the two positions you're seeking to:

**HENRY SCHWAB**  
c/o Personnel Manager  
**STATEN ISLAND CABLE**  
100 Cableway  
Staten Island, NY 10303  
An Equal Opportunity Employer

### CABLE SEARCH ASSOCIATES

Professional Search  
and Placement  
Call or Write **WICK KIRBY**  
(312) 369-2620  
P.O. Box 2347, Naperville, IL 60567  
FAX: 1-312-369-0126

**SEEKING A CHALLENGING CAREER?** Elkhart Telecommunications Co. is looking for I&R technicians who want to work on central office and outside plant telephone equipment, TV cable headend and distribution equipment, mobile phones, and paging equipment. We are located in southwest Kansas in a community of 2500 people. If you want diversity, we got it. Ask for Trent Boaldin at (316) 697-2111.

**Leader in the placement of Cable Television Professionals**  
Call toll free 1-800/433-2160; In Texas call collect 817/599-7623.

**REGIONAL ENGINEER**—Fast track, high growth. East \$50K.  
**TECHNICAL MANAGER**—Northern Cal, new build, growth potential. \$32K + bonus.  
**CONSTRUCTION MANAGER**—Multiple rebuild project. NE \$45K.  
**APPLICATIONS ENGINEER**—BSEE a must, manufacturing environment. SE \$50K.  
**CHIEF ENGINEER**—Newbuild, beautiful SE location. \$32K.  
**PROJECT COORDINATOR**—Tracking, budgets, fast pace. West \$38K.  
**PLANT MANAGER**—Small towns, clustered. SE \$30K.  
**MANAGER/ENGINEER**—Southeast, addressable technology. \$30K.  
**TECHNICAL TRAINER**—Midwest top MSO. \$35K.

**PLANT MANAGER**—Rural Northeast, addressable technology. \$29K.  
**CHIEF TECHNICIAN**—High tech newbuilds Atlantic States. \$33K.  
**MAINTENANCE MANAGER**—Rural New York State, high growth. \$30K.  
**CHIEF TECHNICIAN**—Great Lake State, top MSO. \$32K.  
**HEADEND/MICROWAVE**—Multiple opportunities, nationwide. \$30-\$35K.  
**CHIEF TECHNICIAN**—Atlantic State, small system. \$24K.  
**CHIEF TECHNICIAN**—Large urban southern location, top MSO. \$35K.  
**LINE TECHNICIAN**—Opportunities nationwide, companies will relocate. \$10/hr-\$15/hr.



### JIM YOUNG & ASSOCIATES

One Young Plaza 1235 Ranger Highway Weatherford, TX 76087  
Call for information about these and many other opportunities nationwide.

## Baker Scott & Co. EXECUTIVE SEARCH

1259 Route 46 Parsippany, NJ 07054 201 263-3355

**Specialists in the COMMUNICATIONS INDUSTRY**

CABLE TV/BROADCAST TELECOMMUNICATIONS DIVISION DIVISION

POSITIONS AVAILABLE AT ALL LEVELS OF MANAGEMENT. COAST TO COAST

Call or write in CONFIDENCE

FEE PAID

"WE DON'T TALK CABLE, WE KNOW CABLE"  
PRINCIPALS DAVID ALLEN & JUDY BOUER

### DIRECTOR PROJECT MANAGEMENT

A fast growing MSO seeks a Director of Project Management. The successful candidate must demonstrate in-depth experience managing large capital projects involving multiple locations. Must possess extensive knowledge of all phases of plant construction including engineering and design, documentation, and administration of project data, materials, labor contracts, construction practices and schedules. Principals only.

Qualified candidates may submit resumes to:

**Adelphia Communications Corporation**  
Human Resources Dept., P.O. Box 472  
Coudersport, PA 16915

EOE/M/F/V/H

### Construction/Installation

Experienced needed: linemen, splicers, installers and supervisors. Employee or sub-contractor. Texas and surrounding states. Call or write:

**David McBee**  
Cable Technical Services  
P.O. Box 29065  
Dallas, TX 75229  
214-241-4169

### WANTED

Install Supervisors, Installers, Sales Managers, and Salesmen, for a dynamic and rapidly growing CATV company. Compensation package includes full benefits with great opportunity for advancement. Openings in NC, VA, TX, OK, and KS. Send resume to:

**Mr. Marx**  
P.O. Box 5300  
Norman, OK 73070  
405-329-7255

EOE

## EQUIP. FOR SALE/RENT



### We Buy

AND SELL QUALITY CATV  
EQUIPMENT  
(614) 221-3131  
CABLE LINK, INC.



**EQUIPMENT FOR SALE/RENT**

**EMERGENCY ALERT SYSTEMS**

by  
**Idea/onics**

69 channels 14 day delivery  
compatible with all headends  
—AFFORDABLE—  
(701) 786-3904

24 and 88 channel units  
also available

**CHANNELCUE**

Audio/video switching  
equipment repair

Line equipment  
and meter repair



**LEE ENTERPRISE**

623 4th STREET • P.O. BOX 590 • DEXLER, NEBRASKA 68340  
(402) 365-7520

**WANTED TO PURCHASE:  
SURPLUS CABLE INVENTORY**

Zenith, Jerrold, Oak, Hamlin,  
Scientific Atlanta, Pioneer

**S.C.I. Inc.**  
718-262-0900  
FAX: 718-657-4015

**WANTED:  
SURPLUS CABLE EQUIPMENT**

Jerrold, Oak, Hamlin & Scientific  
Atlanta equipment.

**Highest Prices Paid**  
Cable Equipment Brokerage Co.

(818) 709-3724

**AERIAL BUCKET TRUCKS**

Large selection geared for CATV  
**STANDARD TRUCK &  
EQUIPMENT CO.**  
1155 Hill St. S.E.  
Atlanta, GA 30315  
Phone: 1-800-241-9357



BUCKET TRUCKS

*Anthony's* ANTHONY'S  
MANUFACTURING SERVICE

**PLOW BLADES**  
Irrigation/Wire/Combination  
For Any Machine—For Any Application

1-800-383-PLOW  
(719) 475-PLOW P.O. Box 17701  
Colorado Springs, CO 80935



**Buried Cable and Ground-Fault Loca-  
tor. 90 day warranty. \$550.**

1-800-635-9591

**VIDEO SUPPLIES**

CABLES • CONNECTORS • CANARE • BELDEN • SWITCHCRAFT • D.A.S. • TIES •  
BATTERIES • NEUTRIK • 50 INTERFACE BOXES • TAPE • 500 DIFF. TAPE LABELS • GAFFERS  
TAPE • CASES • PATCH BAYS • LIGHTS • ACOUSTIC FOAM  
• FORMS • MICROPHONES • SONEX • STANDS • MOUNTS  
• WIND SCREENS • ZEPPELINS • FIBRE OPTICS • RACKS  
• DUCT • REELS • TESTERS • FILTERS • CHERMICALS • TOOLS  
• ON AIR LIGHTS • DEGAUSSERS • INTERFACE DEVICES  
• HEADPHONES • CLIPS • SWITCHES • CAM & S-VHS CABLE



**MARKERTEK VIDEO SUPPLY**  
145 Ulster Ave. Saugerties, NY 12477 U.S.A.  
TOLL FREE 1-800-522-2025  
In NY: 914-246-3036

**DYNATEL 500**

Refurbished with cables and 90-day war-  
ranty—\$600

1-800-635-9591

**BUSINESS DIRECTORY**

**Let us give you the Midas Touch!**

We'll buy your new and used CATV equipment  
and turn your surplus into gold!



625 East Taylor Ave.  
Sunnyvale, CA 94086

**CALL NOW!**  
1-800-228-0633

**ColorView Services, Inc.**

800-824-1943

SINCE 1953

**CONVERTER REPAIR**

**REALISTIC TURNAROUND**  
PROGRAMMABLE & ADDRESSABLE

JERROLD HAMLIN PANASONIC OAK SCIENTIFIC  
ATLANTA TEXSCAN

ASK ABOUT OUR PRICES! SIX MONTH WARRANTY!  
ALBUQUERQUE, NEW MEXICO



**CONTRACT INSTALLERS, INC.**

UHF Radio Equipped Trucks • Uniformed Installers

**HOUSE INSTALLATIONS**  
Aerial • Underground • Pre-wire  
**APARTMENT INSTALLATIONS**  
Post wire • Pre-wire • Commercial Building  
Tap Audits

Install or Remove Traps and/or Converters  
Drop change over for System Rebuilds

LENNY FISCHER  
(414) 582-7087

P.O. Box 1564  
Appleton, Wisconsin 54913-1564

**TSB, Inc.**



- Design, Strand Map, As-Builts
- CAD Drafting Service
- Headend Racking and Renovations
- CLI • Audits
- Onsite Technical Training
- Structural Analysis of Towers

PO Box 244  
(605) 665-1393

Yankton, SD  
57078

# White Sands

## Jumper Cables

Custom connectors and cables for all aspects of CATV.  
 Gilbert AHS All types of cable from  
 Magnavox Belden  
 Pyramid F59-81 Times  
 LRC and others Comm Scope  
 Quick delivery on all colors with lengths from 6" to 15'.

Write or call: (602) 581-0331  
 335 West Melinda Drive, Phoenix, AZ 85027

## CABLE CONSTRUCTORS, INC.

IRON MOUNTAIN, MICHIGAN  
 COAX - FIBER

QUALITY SERVICE PERFORMED ON A TIMELY BASIS  
 - SINCE 1957 -

MAPPING - DESIGN - CONSTRUCTION - ENGINEERING

## CABLE CONSTRUCTORS, INC.

1-800-338-9292

KLUNGNESS ELECTRONIC SUPPLY (KES)

1-800-338-9299

## NaCom

BUILDING COMMUNICATION SYSTEMS THROUGHOUT AMERICA

- Installations (including fiber optics)
- Converter exchanges, PPV, audits, special projects
- MDU, SMATV, & LAN Pre/postwiring
- Strand mapping, engineering, signal leakage
- Design (AutoCAD)
- Aerial/underground construction

1900 E. Dublin-Granville Rd., Columbus, Ohio 43229  
 614/895-1313 • FAX 614/895-8942



BB LAN, MATV & CATV Design  
 Network Certification  
 System Upgrades & Extensions  
 CLI & Application Engineering  
 CADD

## CABLE SYSTEMS ENGINEERING INC.

Providing Data & Video Broadband  
 Engineering Services

2820 Flamango Lakes Drive  
 West Palm Beach, FL 33406

(407) 684-3913

## ADVERTISER'S INDEX

	Reader Service #	Page #
A.D.S. Inc.	.62	.95
Access Logic Technologies	.37	.60
Alpha Technologies	.26	.47
Anixter Cable TV	.44, 71	.69, 112
Augat Broadband	.13	.25
Augat LRC Electronics	.18	.39
Automation Techniques/Tulsat	.34	.58
Avcom of Virginia	.59	.91
C-COR Electronics	.12	.23
CATV Services Inc.	.60	.91
Cable Exchange	.67	.108
Cable Link	.47	.72
Cable Prep/Ben Hughes Comm.	.20	.42
Cable Services	.58	.89
Channel Commercial	.4	.6-7
Channelmaster	.66	.107
Computer Utilities of the Ozarks	.35	.58
Comnet	.38	.61
Commscope	.27	.49
Eagle Comtronics	.68	.109
Financial News Network	.49	.75
General Inst./Jerold	.15	.33
General Cable Apparatus Div.	.24	.45
Hudson Supply	.11	.21
ISS Engineering	.32	.54-55
Jackson Tools	.45	.70
Leaming	.64	.81
Lectro Products Inc.	.39	.63
Lemco Tool	.56	.101
Lindsay Specialty Products	.63	.97
Line-Ward	.57	.87
Magnavox CATV	.19	.41
Microwave Filter	.28	.50
Midwest CATV	.6	.12-13
Midwest CATV Engineering	.21	.42
Midwest Communications	.8	.17
Multilink	.50	.76
Nexus Engineering	.3	.5
Oak Communications	.52	.79
Panasonic	.1	.2
Performance Plus	.25	.46

## Cable Technical Services

- Construction
- Engineering
- Installation

Contact: Jerry Blount  
 214-241-4169

PO Box 29085, Dallas, TX 75229

Pico Macom	.54	.84
Pico Products	.40	.65
Pioneer Communications	.31	.53
Power Guard	.14	.27-30
Power & Telephone Supply	.9	.18
Quanta	.23	.44
Reliable Electric	.70	.111
Ripley Company Inc.	.43	.68
Riser-Bond	.65	.101
Rite Cable	.29	.50
Scientific-Atlanta	.7, 16	.15, 34-37
Standard Communications	.10	.19
TVC Inc.	.22	.43
Telecommunication Products Corp.	.51	.77
Texscan Corp.	.33	.57
Texscan MSI	.61	.93
Time Manufacturing	.48	.73
Times Fiber	.30	.51
Trilithic Texscan Inst.	.55	.85
Trilogy Communications	.2	.3
Triple Crown Electronics	.69	.110
Uniden	.5	.11
Washington Cable	.36	.59
Wavetek	.53	.83
Wegener Comm.	.42	.66-67
Zenith	.46	.71

# Under \$95,000!

**MICRO-BEAM® 5-Watt Transmitter,  
3 Receivers, 60 Channel System...Installed.**

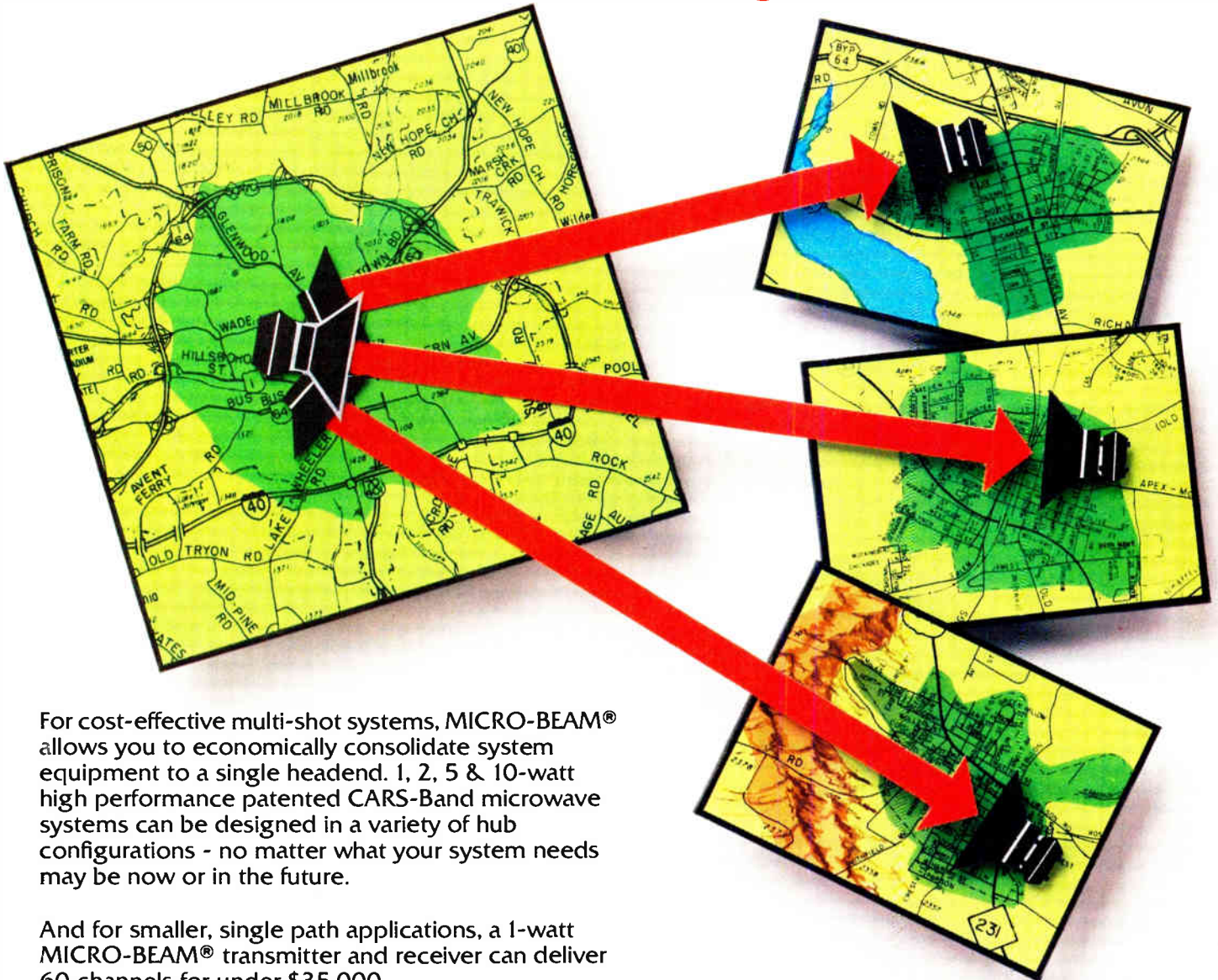

For cost-effective multi-shot systems, MICRO-BEAM® allows you to economically consolidate system equipment to a single headend. 1, 2, 5 & 10-watt high performance patented CARS-Band microwave systems can be designed in a variety of hub configurations - no matter what your system needs may be now or in the future.

And for smaller, single path applications, a 1-watt MICRO-BEAM® transmitter and receiver can deliver 60 channels for under \$35,000.

### **All MICRO-BEAM® Systems are:**

- Fully weatherized for tower mounting
- Rigorously tested and computer monitored for 1000 hours
- In-stock, giving you the fastest lead time in the industry
- Backed by a 24-hour, 7-days a week technical and warranty service.\*

\*Continental U.S. Only.

The MICRO-BEAM® standard equipment and service package comes complete with everything

you need to make your system operational (excluding antennas and towers), so you won't have to worry about "high cost" options.

For more information on how you can make your cable system more profitable, contact:  
**Jim Crowover, MICRO-BEAM® Sales Manager.**

See us at Atlantic Cable '89, Booth #313, East Hall.

**Channel Master®** Division of Avnet, Inc.

P.O. Box 1416, Industrial Park Drive, Smithfield, N.C., 27577 (919) 934-9711

Prices subject to change without notice.

# Discover The POWER Behind Cable Exchange

■ If you need it we'll find it

■ Excess inventory management for major MSO's

■ Warranty available on everything we sell



CBLX

5730 E. OTERO • SUITE 700 • ENGLEWOOD, CO 80112

IN CO: 303-694-6789  
OUTSIDE CO: 800-777-2259

## IN THE NEWS

catalog, on a disk, that contains a complete description of Xentek's product line including standard, custom, tailored combinations, ferroresonant and unregulated power supplies. The linear catalog and its data base are stored on a single 5¼ inch, 360 kilobyte floppy disk. The program is menu-drive and features cognitive pop-up help screens. To obtain a copy or for info call (619) 727-0940.

**Master Bond Inc.** has introduced its two-page application selector guide on thermally conductive, electrically insulative epoxy systems. Viscosity, gel times, service operating temperature ranges, thermal conductivity and application recommendations are listed for 15 Master Bond grades. For info call (201) 343-8983.

### Fiber loss test set

The **Augat Communications Group** introduced the **Fiberoptic Connector Length Gauging System**. The system allows operators to polish, use the gauging system to read the end length, then repolish the connector as necessary, without having to disconnect the connector from the polishing tool. Two versions of Gauging systems are available, one is a benchtop version for factory or laboratory use; the other is a handheld version for field use. Features of the Gauging system include customer specified polish length, tungsten carbide ball bearings for polish tool support, 100 percent waterproof transducers and optional gauge calibration standards available for both the SMA and biconic connector systems.

Also available from the Augat group

is a new connector curing oven designed as a means to epoxy cure all fiber optic connector types. The temperature of the oven is regulated with a thermostat-controlled temperature dial. The dial is UL approved and provides temperature accuracy to within  $\pm 5$  percent of set temperatures. The oven is capable of reaching 200° fahrenheit (93° centigrade) in ten to fifteen minutes. For details on both products call (206) 932-8428.

**Fotec, Inc.** has announced the addition of a new optical loss test set (OLTS) for singlemode fibers. The Model T412 OLTS combines a new fiber optic

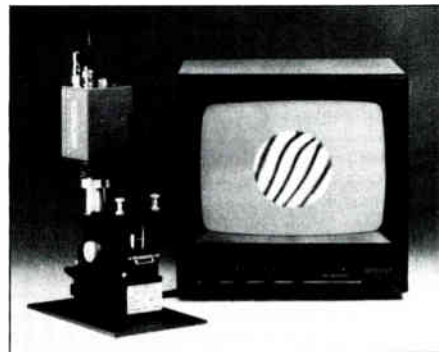

Norland's Cleave-Chek Interferometer

power meter, Model M411, which has measurement ranges for both absolute power in dBm or microwatts and a relative dB range for cable plant loss. The laser sources used are the new S480 series which offer 1300 nm, 1500 nm or dual wavelength outputs. The T412 OLTS can measure loss of single mode cables of 40 dB or more. For more info call (800) 537-8254 or (617) 241-7810 in Mass.

**Norland Products** has introduced



Fotec's Model T412 OLTS

# EAGLE'S OUTDOOR ADDRESSABLE TRAP SYSTEM AN ALTERNATIVE TO SET TOP DESCRAMBLERS FINALLY: CONSUMER FRIENDLINESS WITH IMPULSE PPV

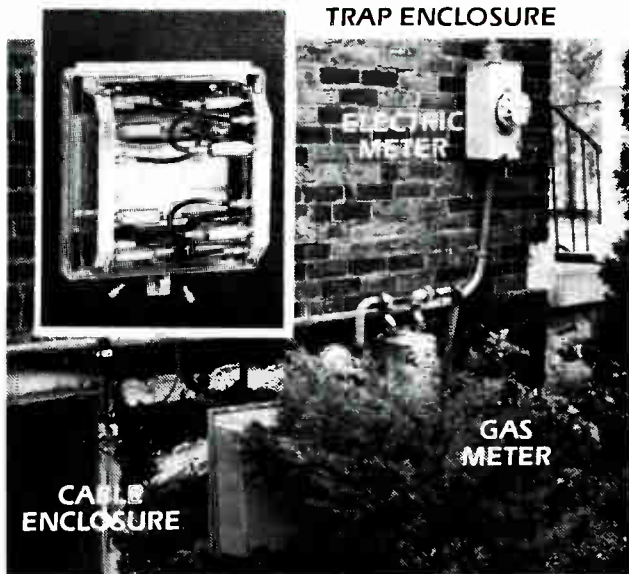

TYPICAL INSTALLATION

**Addressable Trap System** eliminates many of the consumer unfriendly characteristics of present day converter descramblers. **Eagle's Addressable Trap System** provides:

- (A) Ability to record a premium channel while watching a different premium channel.
- (B) A converter descrambler is not required for each TV.
- (C) TV and VCR remote controls can be used.
- (D) Cable ready sets can use their extra channel capacity possibly eliminating a converter.
- (E) Picture and sound distortions are minimized.
- (F) Switch boxes or complicated wirings are not required.

A trapped system is very friendly since all subscribed to channels are present at each TV set simultaneously in an unscrambled mode. Only undesired channels are removed. When addressability and Impulse pay-per-view are added, as with **Eagle's Addressable Trap System**, consumer friendliness, versatility, and economy for today's system operator are the result. The control box in which the traps are located is outside the home similar to electric, gas or water meters, eliminating the need for customer change of service or repair scheduling.

One hundred million traps used in cable systems testify to their reliability, simplicity, and economics for controlling premium channels. Adding **Addressability** and **IPPV** to basic traps, will extend their use many years into the future.

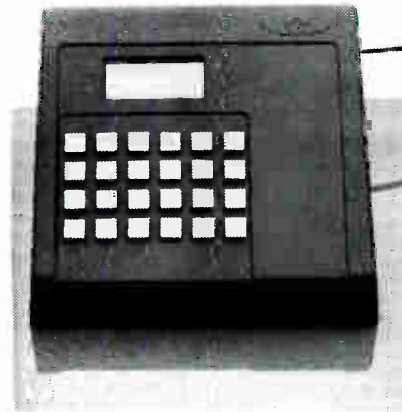

OPTIONAL REMOTE UNIT

## FEATURES

- 4 or 8 tiers of negative, positive or multichannel addressable filters; 256 combinations selectable.
- Consumer friendly with VCRs, cable ready sets, and remote controlled TVs.
- Controls signal delivery to multiple TV sets from one trap switch enclosure.
- Uses your present negative or positive traps.
- Powered from the home; cable system powering changes not required.
- All service disconnect capability; over 80 dB isolation.
- Non-volatile memory protects data during power outages.
- Automatic scheduling of events & previews.
- No need to enter home for audits.
- Automatic shut-down after time out.
- IBM PC or compatible computer control.
- Billing program; compatible with billing systems.
- Transparent to other scrambling technology.
- Compatible with non-attended remote headends.
- Ground block.
- Non-interrupted test points.

## OPTIONAL REMOTE UNITS

- Subscribe to premium programming without need to call the cable system; order IPPV by event number.
- Auto-dialer transmits customer usage back to the system operator, using store and forward techniques.
- Pre-authorize customers for limited amounts of pre-paid programming.
- Parental Control of premiums or all service.



4562 Waterhouse Road, Clay, NY 13041 (315) 622-3402 TOLL FREE 800-448-7474  
 In Canada: Deskin Sales • Montreal • Toronto • Vancouver • 416-475-1412  
 In Europe: Electro Service • Belgium • 011-32-15-20-95-75  
 • Cabiecom AS • Norway • 011-47-34-67800 • Stodiek • W. Germany • 011-211-41-7010

Reader Service Number 68

the Cleave-Chek Interferometer System which incorporates a fiber interferometer with a solid-state CTV camera and video monitor for inspection of a cleaved optical fiber. The Cleave-Chek works by providing an interference pattern between the fiber face and a reference optical flat. The fiber end is illuminated by a red LED which gives a sharp fringe pattern. The number of fringes is counted by viewing the fiber face on a 9-inch monitor. For info call (201) 545-7828.

Available from AMP is a family of singlemode and multimode couplers for use as splitters, combiners or taps in

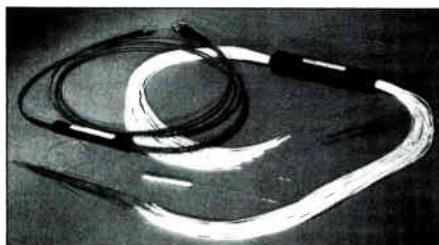

*The AMP family of couplers*  
optical communication and subscriber loop systems, fiber-optic networks and test/sensor systems. Standard input/output configurations are 1X2 and 2X2, and can be cascaded or combined

to form singlemode tree and star couplers such as 1X8's or 8X8's. For more info call (800) 522-6752.

**New pigtailed optical isolator**

A pigtailed polarization independent optical isolator is now available from **BT&D Technologies**. The OIC1100 family is designed for use in singlemode fiber optic systems in the 1300 nm and 1550 nm bands.

The pigtailed optical isolator transmits light in one direction at low loss (maximum, 2.0 dB, typical, 1.5 dB), while attenuating light in the opposite direction. The device has an isolation of 35 dB or more and a return loss of greater than 60 dB. The OIC1100 series is useful in preventing back reflections into DFB and external cavity lasers.

BT&D Technologies also announced a new coupler appropriate for use in high volume applications such as fiber-to-the-home. The addition to the SMC0102 family provides splitting and combining of optical signals at wavelengths of 1300 nm, 1310 nm or 1550 nm. For info on either item, call (302) 479-0300 or (800) 545-4306. ■

—Kathy Berlin

*Continued from page 88*  
offending system but perhaps the entire cable industry. ■

**References**

1. FCC Rules and Regulations Part 76.
2. *The ARRL Handbook for the Radio Amateur*, American Radio Relay League, 225 Main Street, Newington, Conn. 06111.
3. *Transmitter Hunting—Radio Direction Finding Simplified*, by Joseph D. Moell and Thomas N. Curlee, Tab Books Inc., 1987.

**Correction**

In *CED's* recent Signal Leakage Handbook, copy was inadvertently omitted in Part 76: FCC Rules and Regulations (beginning on page 12). Section 76.612 (pg. 16), subsections (1) and (2) should read:

- (1) All such cable carriers or signal components shall be offset by 12.5 kHz with a frequency tolerance of  $\pm 5$  kHz; or
- (2) The fundamental frequency from which the visual carrier frequencies are derived by multiplication by an integer number which shall be 6.0003 MHz with a tolerance of  $\pm 1$  Hz (Harmonically Related Carrier (HRC) comb generators only).



**Extended Value**

Broad application Mini Trunk Line Extender Triple Crown Model: LA4229. Over two decades of innovative electronics experience is built into each and every Triple Crown amplifier. This assures you of dependable performance and excellent value.

- Selectable Bandwidth up to 450 MHz.
- Dual integrated circuit design.
- Automatic Level Control (LA4229ALC).
- 29dB Gain.
- Two way capability.
- Single "snap-in" module.
- 18-60 Volt switching mode high efficiency power supply.
- All input and interstage Controls built in.
- External test points.
- Corrosion resistant housing with stainless steel hardware.

4560 Fieldgate Drive  
Mississauga, Ont. L4W 3W6

(416) 629-1111  
800-387-3205 (U.S. Only)

**TRIPLE CROWN  
ELECTRONICS**



**ONLY \$250.00**  
\$275.00 with ALC

# Replace in 2014 A.D.

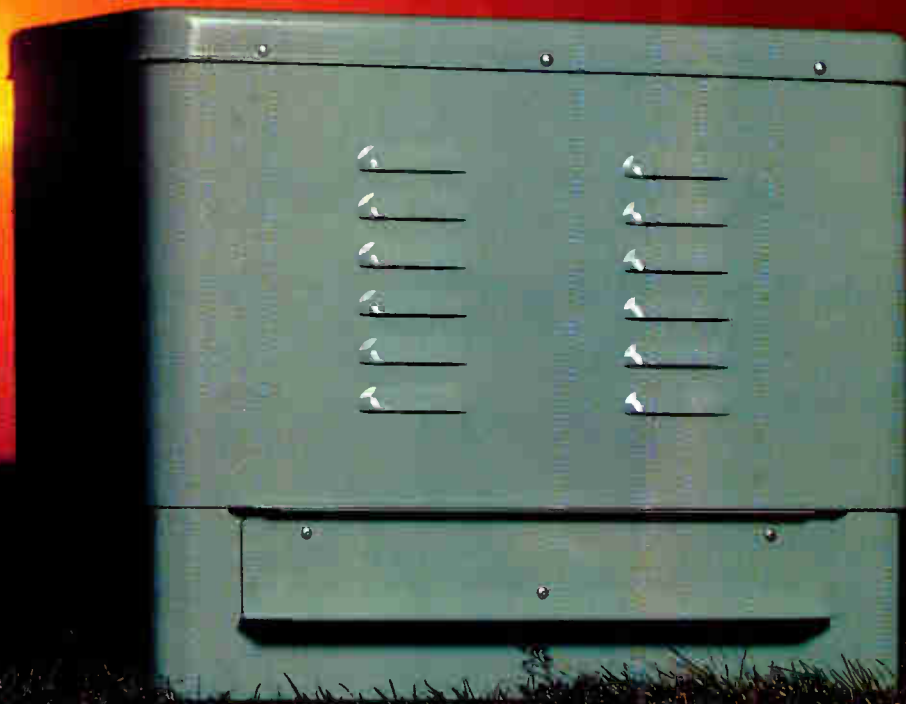

Anixter Cable TV stocks the complete line of Reliable pedestals because they're made to last. Made to last, because it's just good business to protect valuable equipment inside quality enclosures.

Reliable's products are made to outlast the equipment inside. They average 25 years in use. Buy today and don't think about replacement until 2014.

Reliable's nine-step finishing process generates a high gloss weather-fighting finish that resists corrosion

and the onslaughts of acid rain, pollutants and other atmospheric contaminants.

For more information about the full line of Reliable pedestals, call the Anixter Cable TV distribution center in your area.

**RELIABLE**

RELIANCE COMM/TEC

**ANIXTER**  
CABLE TV

**WEST-ANAHEIM:** (714) 779-0500, (800) 854-0443; **DENVER:** (303) 740-8949, (800) 841-1531; **SEATTLE:** (206) 251-6760, (800) 426-7665; **MIDWEST-CHICAGO:** (312) 364-7000, (800) 544-5368; **CLEVELAND:** (216) 526-0919, (800) 321-8068; **DALLAS:** (214) 446-7337, (800) 231-5006; **IRON MOUNTAIN, MI:** (906) 774-4111, (800) 624-8358; **SKOKIE, IL HDQTRS:** (312) 677-2600; **EAST-ATLANTA:** (404) 995-5110, (800) 241-5790; **LONG ISLAND, NY:** (516) 293-7788, (800) 645-9510; **NEW JERSEY:** (201) 328-0980, (800) 631-9603; **TAMPA:** (813) 626-7115, (800) 282-9164; **CANADA-CALGARY:** (403) 250-9646; **MONTREAL:** (514) 636-3636; **TORONTO:** (416) 625-5110; **VANCOUVER:** (604) 321-5885

In an emergency, weekends and holidays or after 5 PM call toll free 1 (800) 323-8166.  
CORPORATE OFFICES, ANIXTER CABLE TV, INC., 4711 Golf Road, Skokie, IL 60076, (312) 677-2600

1989 ANIXTER CABLE TV

Reader Service Number 70

# Install **REGAL** quality in your system today!

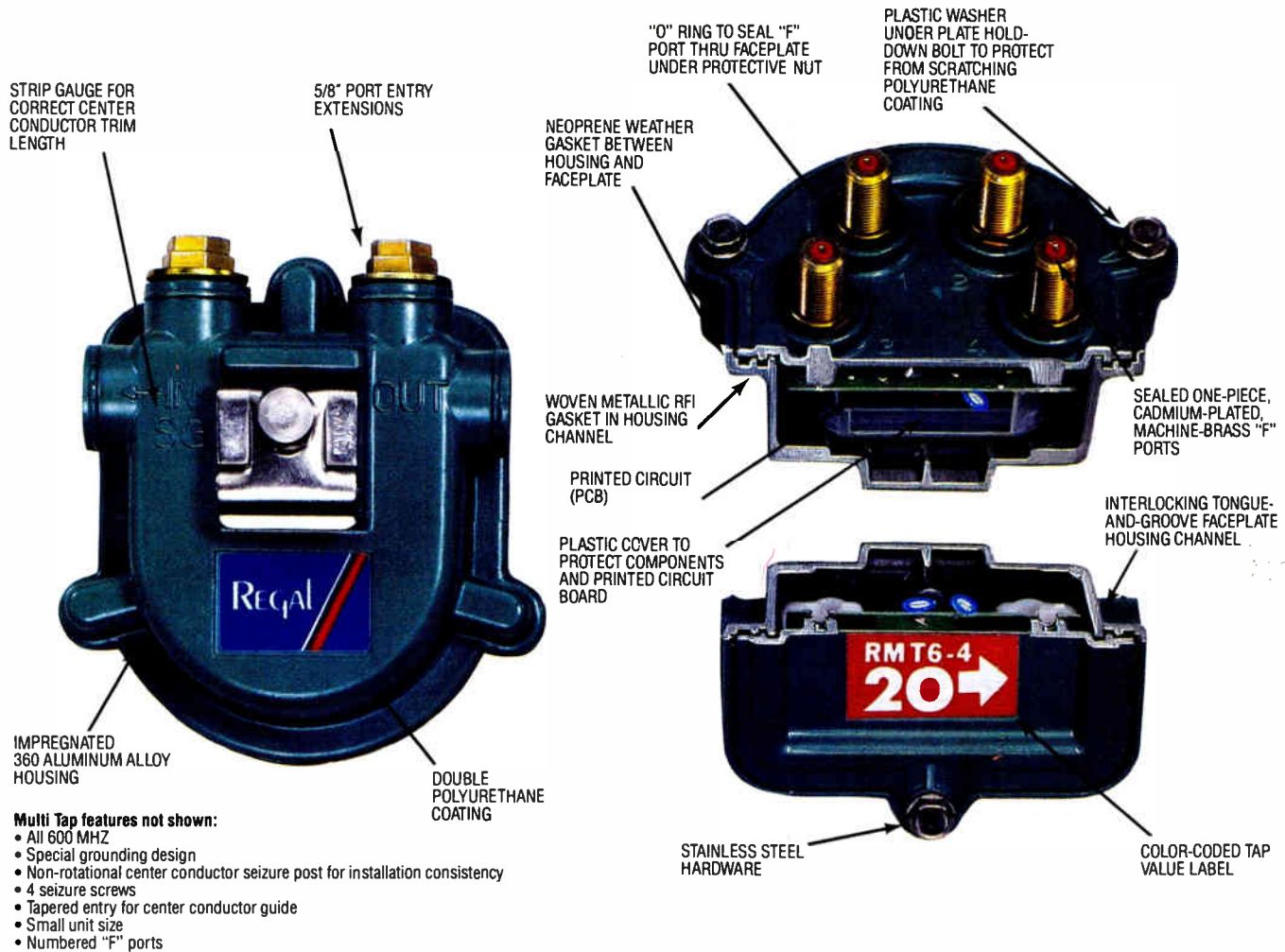

Regal taps and line passives have become widely used in the Cable TV industry since Anixter introduced them in 1982. Regal multi-taps, line passives and drop passives are in stock through Anixter's nationwide network to meet your construction and installation needs.

Contact the Anixter Cable TV location nearest you to place your order, or to receive the new Regal Multi-Tap Data Sheet and the complete Regal product brochure.

Visit Anixter Booth #141 at the Atlantic Cable Show

## ANIXTER CABLE TV

Reader Service Number 71

**WEST-ANAHEIM:** (714) 779-0500, (800) 854-0443; **DENVER:** (303) 740-8949, (800) 841-1531; **SEATTLE:** (206) 251-6760, (800) 426-7665; **MIDWEST-CHICAGO:** (312) 364-7000, (800) 544-5368; **CLEVELAND:** (216) 526-0919, (800) 321-8068; **DALLAS:** (214) 446-7337, (800) 231-5006; **IRON MOUNTAIN, MI:** (906) 774-4111, (800) 624-8358; **SKOKIE, IL HDQTRS:** (312) 677-2600; **EAST-ATLANTA:** (404) 995-5110, (800) 241-5790; **LONG ISLAND, NY:** (516) 293-7788, (800) 645-9510; **NEW JERSEY:** (201) 328-0980, (800) 631-9603; **TAMPA:** (813) 626-7115, (800) 282-9164; **CANADA-CALGARY:** (403) 250-9646; **MONTREAL:** (514) 636-3636; **TORONTO:** (416) 625-5110; **VANCOUVER:** (604) 321-5885.

In an emergency, weekends and holidays or after 5 P.M. call toll free 1 (800) 323-8166.  
CORPORATE OFFICES, ANIXTER CABLE TV, 4711 Golf Road, Skokie, IL 60076, (312) 677-2600

©1989 Anixter Cable TV