

# CEED

MAGAZINE OF BUSINESS AND TECHNOLOGY MAY 1989

\*\*\*\*\*ALL FOR STATE  
46295 991231 CEDF 1 583  
FRED MC CORMACK  
PRAIRIEWOOD STATION  
BOX 9077  
FARGO ND 58106 9077

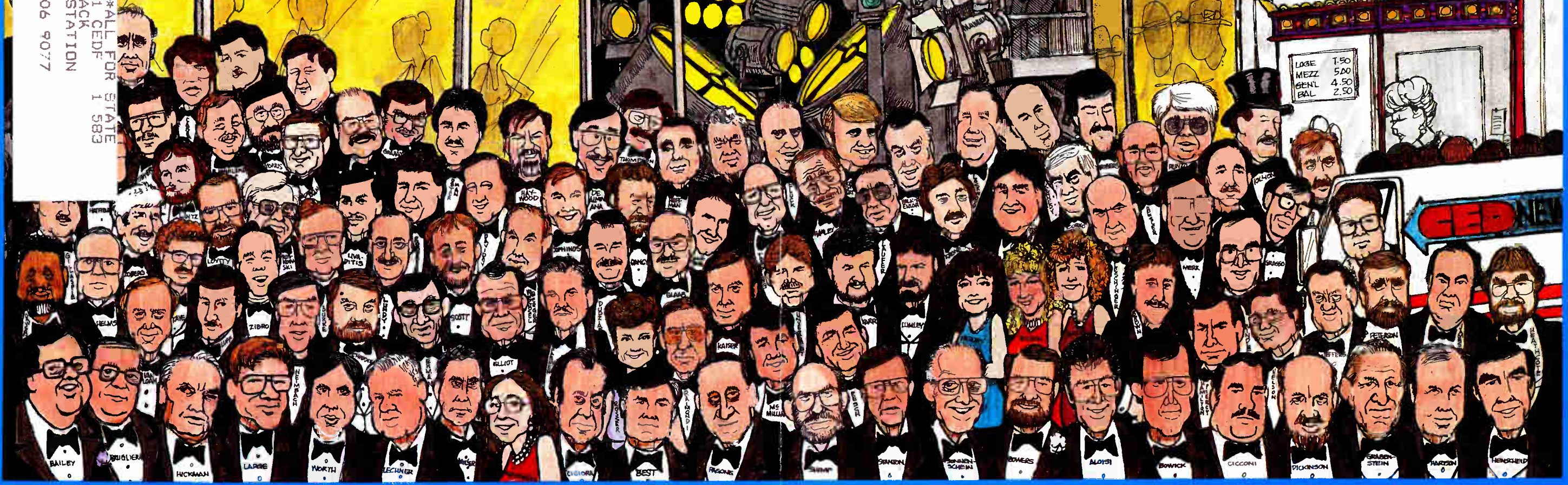

NOW SHOWING  
**STARRING  
IN  
DALLAS**

WELCOME  
CABLE  
CELEBRITY

Attack of  
the Killer  
Telco's

COMING ATTRACTION  
Rocky Cable  
IV  
SYLVESTER STALLION  
Scouring TED TURNER

FATAL TV  
ATTRACTION

Strange  
Encounters  
of the  
Cable  
Kind

LOSE 1.50  
MEZZ 5.00  
GENL 4.50  
BAL 2.50

CEED



# COMM/SCOPE HAS CABLEGUARD.

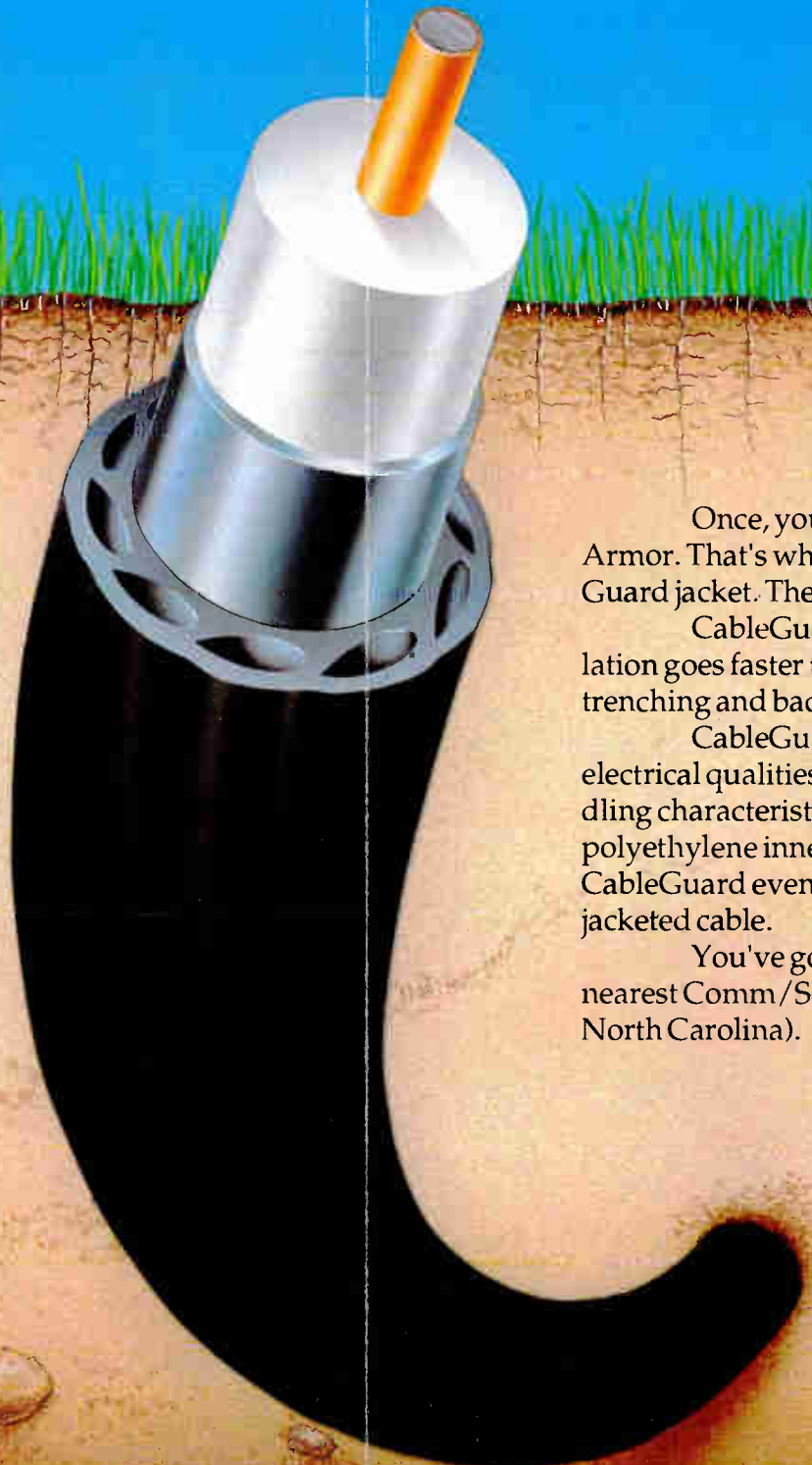

Physical Dimensions	500 Series	625 Series	750 Series
Nominal Center Conductor Diameter	0.109 in. 2.77 mm.	0.137 in. 3.48 mm.	0.167 in. 4.24 mm.
Nominal Diameter Over Dielectric	0.450 in. 11.43 mm.	0.563 in. 14.30 mm.	0.678 in. 17.22 mm.
Nominal Diameter Over Outer Conductor	0.500 in. 13.70 mm.	0.625 in. 15.88 mm.	0.750 in. 19.05 mm.
Nominal Outer Conductor Thickness	0.025 in. 0.64 mm.	0.031 in. 0.79 mm.	0.036 in. 0.91 mm.
Nominal Diameter Over Jacket	0.750 in. 19.05 mm.	0.875 in. 22.23 mm.	1.055 in. 26.80 mm.
Nominal Jacket Wall Thickness - Inside Jacket	0.025 in. 0.64 mm.	0.025 in. 0.64 mm.	0.025 in. 0.64 mm.
Nominal Jacket Wall Thickness - Outside Jacket	0.030 in. 0.76 mm.	0.030 in. 0.76 mm.	0.030 in. 0.76 mm.
Mechanical Characteristics			
Minimum Bending Radius	8.0 in. 20.3 cm.	9.0 in. 22.9 cm.	10.0 in. 25.4 cm.
Maximum Pulling Tension	200 lbs. 91 kg.	295 lbs. 134 kg.	420 lbs. 190 kg.

Once, you had only one real option when you needed additional cable protection. Armor. That's why Comm/Scope invented and introduced our exclusive patented CableGuard jacket. The only cable to offer a cost-effective and practical alternative to armor.

CableGuard saves money two ways; it costs less to buy and costs less to install. Installation goes faster than armor because you can plow CableGuard. Armor installation requires trenching and backfilling. CableGuard splices faster, too.

CableGuard outperforms any conventional coax made. It combines exceptional electrical qualities, like any of our fine PIII products, with outstanding protective and handling characteristics not found this side of a full metal jacket. CableGuard has medium density polyethylene inner and outer jackets joined in a patented process by shock-absorbing splines. CableGuard even outperforms armored cable in most impact tests yet is as flexible as standard jacketed cable.

You've got everything to gain with CableGuard. For more information, contact your nearest Comm/Scope representative or call Comm/Scope, Inc. 800-982-1708 (800-222-6808 in North Carolina).

**Comm/Scope, Inc.**  
THE Cable in Cable TV.

Post Office Box 1729, Hickory, NC 28603, Phone 800-982-1708  
(800-222-6808 in NC), Fax: 704-328-3400, Telex: 802-166



**FOR WHEN YOU  
DON'T NEED  
ARMOR.**

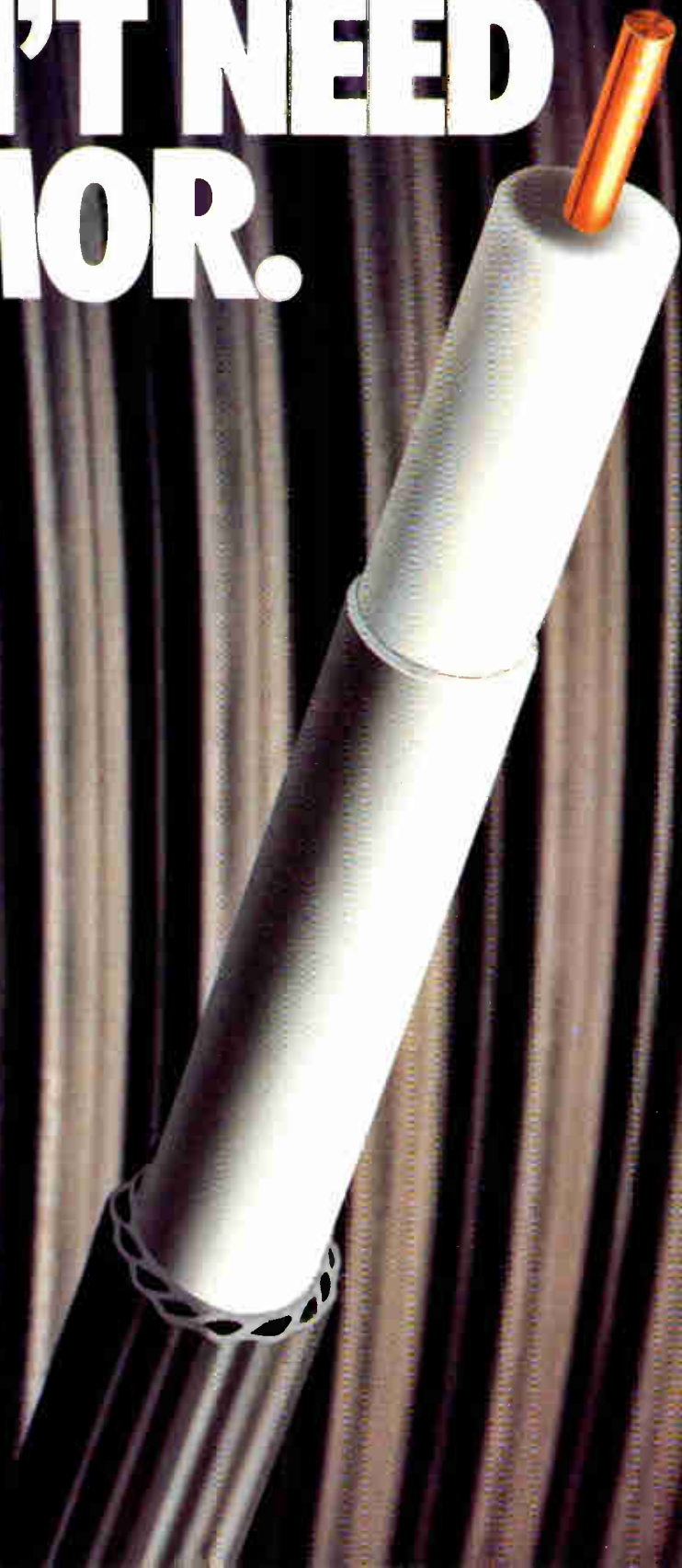



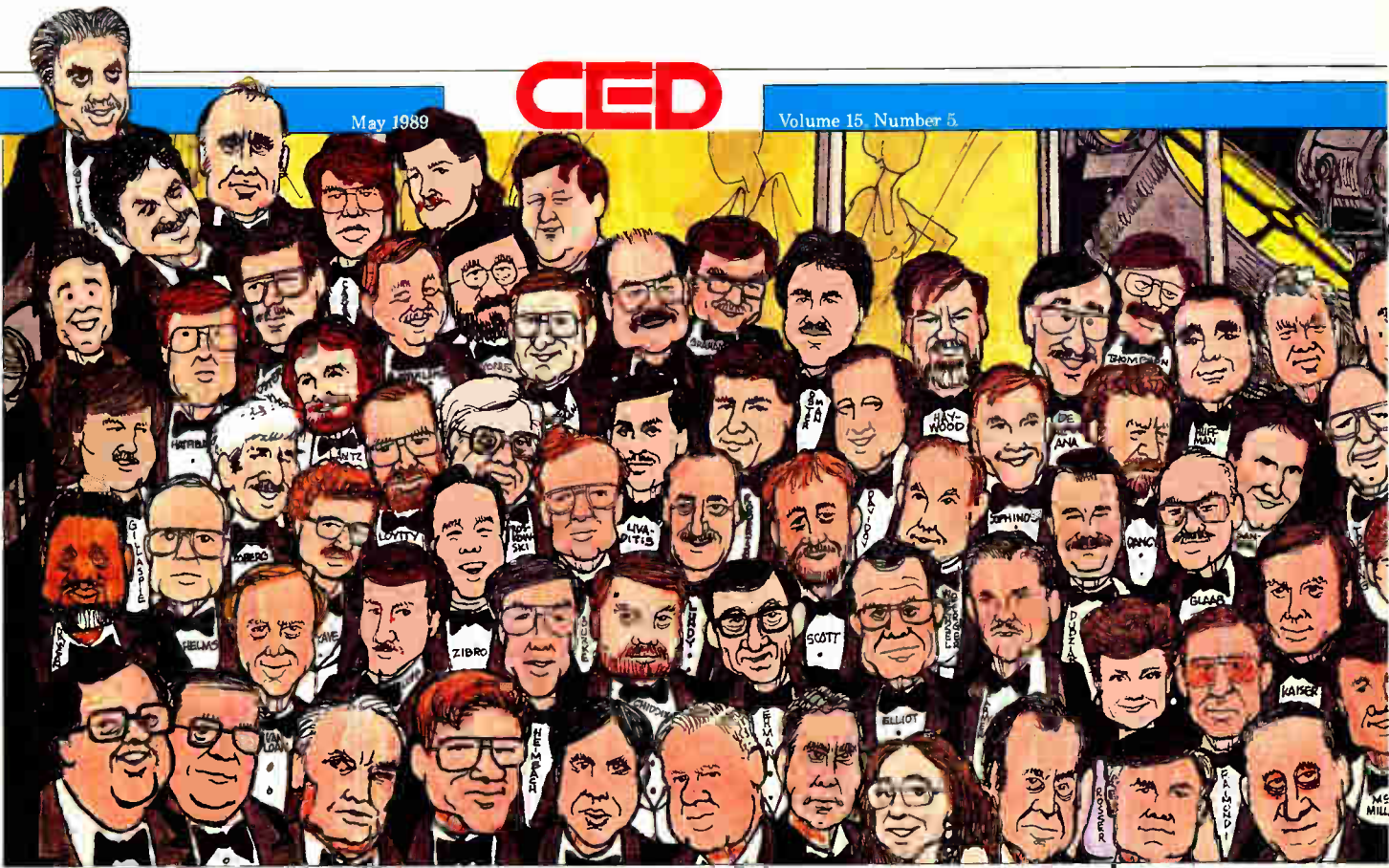

**Looking inside the CATV amplifier**

Karl Poirier, with Triple Crown Electronics, examines the inner workings of one of the most commonly handled pieces of CATV equipment. In Part I of his paper, basic circuit assemblies are explored along with a discussion of the manufacturer's design criteria.

**20** Ku-band satellite, page 36

**Ku-band future uncertain**

1989 is clearly the year of decisions for the cable industry and its satellite vendors. This article analyzes the commitments to C-band satellite replacement and the future of Ku-band satellites for CATV program distribution and Direct Broadcast Satellite systems.

**36**

**A wireless alternative for consumer satisfaction**

Although seen by many in the CATV industry as being problem-bound, wireless cable operators are offering a choice to consumers in wired territories. A look at this simple technology and the political debate it has inspired is the thrust here.

**46**

**Using the agile modulator in headend design**

As the use of agile modulators has increased, so have the arguments as to its relative worth. Ken Pyle of ISS Engineering Inc. reviews the advantages to using an agile modulator versus the fixed channel modulator.

**56**

**Laser makers beam in on CATV market**

The cable industry's quantum leap into fiber optics has rekindled research efforts by laser manufacturers who would like a piece of the action in the analog world. Fred Dawson of *CableVision* magazine goes in-depth to explore the players and the market for cable-designed lasers.

**64**





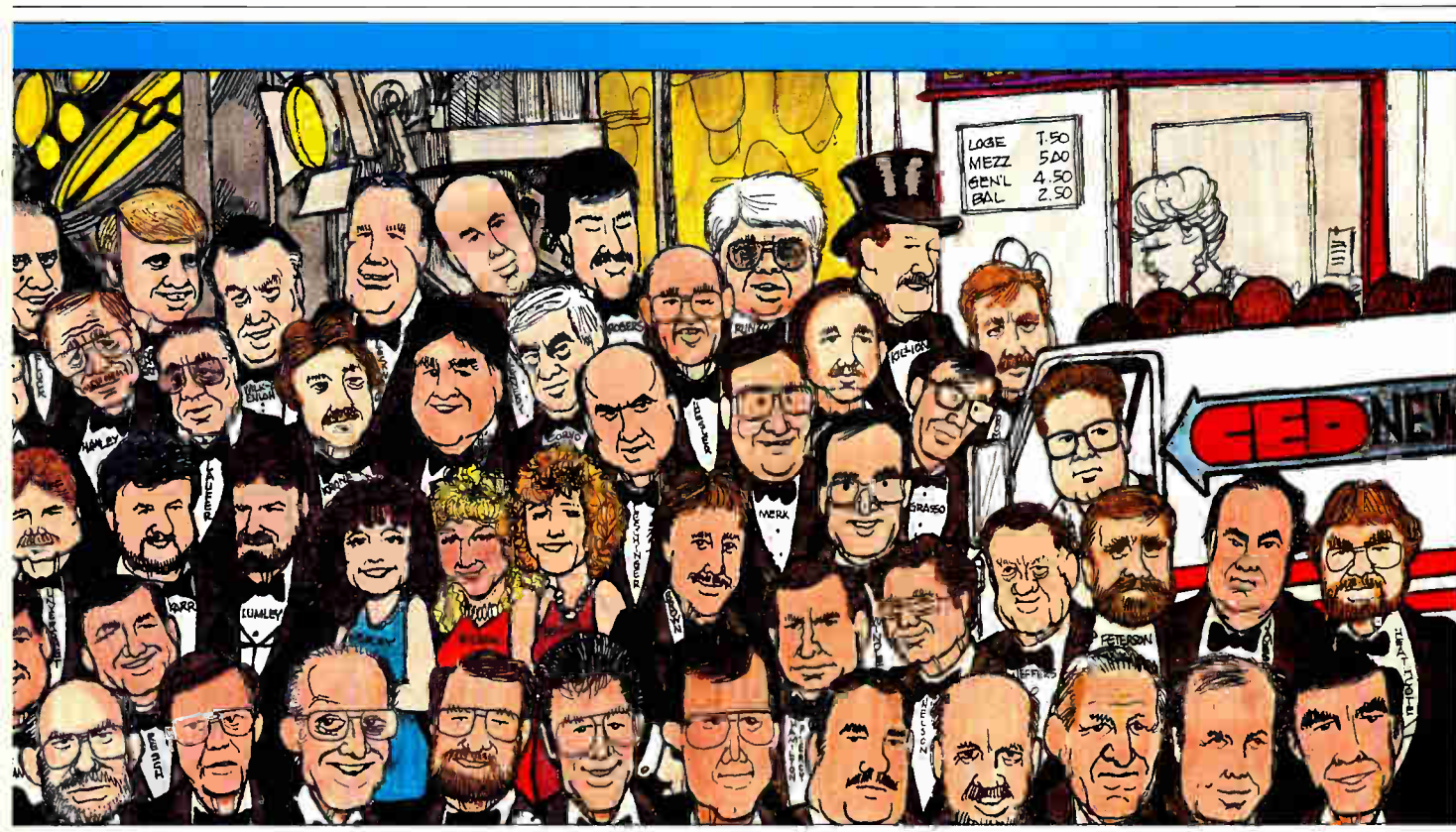

**More on fiber**

While the industry debates the merits of AM versus FM transmission on fiber, consultant Gary Moore examines technical reasons as to why neither is a viable system for the long-term.

**74**

**Opening new 'windows' for PPV**

As the PPV market matures, the ability to protect programming is crucial in order to receive earlier releases. John Ryan of Macrovision Corp. discusses anticopy technology and its implications for the future of PPV.

**84**

**Dialing for entertainment**

With consumers becoming accustomed to picking up their telephones to order movies, T.J. Watson of Science Dynamics Corp. explains the MACBS® technology behind the call and how it uses ANI to process the transaction.

**94**

**Interconnecting via satellite**

In order to serve advertising needs of a large ADI consisting of several different franchises, a unique approach may be the only solution. Norman Weinhouse, with Weinhouse & Associates, describes one such method using satellite implementation.

**98**

**Rebuilding amidst technical considerations**

Jon Ridley with Jerrold's Distribution Systems Division explores justifications for rebuilding and alternative methods for completing the rebuild. Subscriber annoyance and possible revenue streams are just two implications he examines.

**110**

**Traps vs. addressability: Is there a winner?**

After years of debate, off-premise addressable systems are making progress against their old rival—traps. This article examines some of the current off-premise technology and the vendors who are starting to make headway.

**120**

**About the Cover:**

*The NCTA Engineering Committee is joined by industry hardware vendors in black tie outfits for the gala event in Dallas, site of the 1989 National Cable Show. For a list of everyone shown, see page 115. Art by Rob Pudim.*

DEPARTMENTS

**In Perspective . . . . .10**  
**Spotlight . . . . .12**  
**Frontline . . . . .14**  
**From the Headend . . . . .16**  
**Capital Currents . . . . .18**  
**Back to Basics . . . . .104**  
**Who's on the Cover . . . . .115**  
**NCTA Show Sessions . . . . .116**  
**What's Ahead . . . . .126**  
**Classifieds . . . . .128**  
**Ad Index . . . . .130**  
**In the News . . . . .131**

©1989 by International Thomson Communications Inc. All rights reserved.  
 CED, (USPS 330-510) (ISSN 0191-5428) is published monthly except twice in May by International Thomson Communications Inc., 600 S. Cherry St., Denver, CO 80222. May 1989, Volume 15, Number 5. Subscriptions free to qualified industry readers. All other one-year subscriptions are \$36, prepaid in U.S. funds only. Second-class postage paid at Denver, CO, and additional mailing offices. CED is published on behalf of the cable television and broadband communications industries. POSTMASTER: Please send address changes to 600 S. Cherry St., Suite 400, Denver, CO 80222. MEMBERS OF THE BPA.





# Integral and **Setting the s undergro**

*1 1/4" Duct with  
.750 coax*

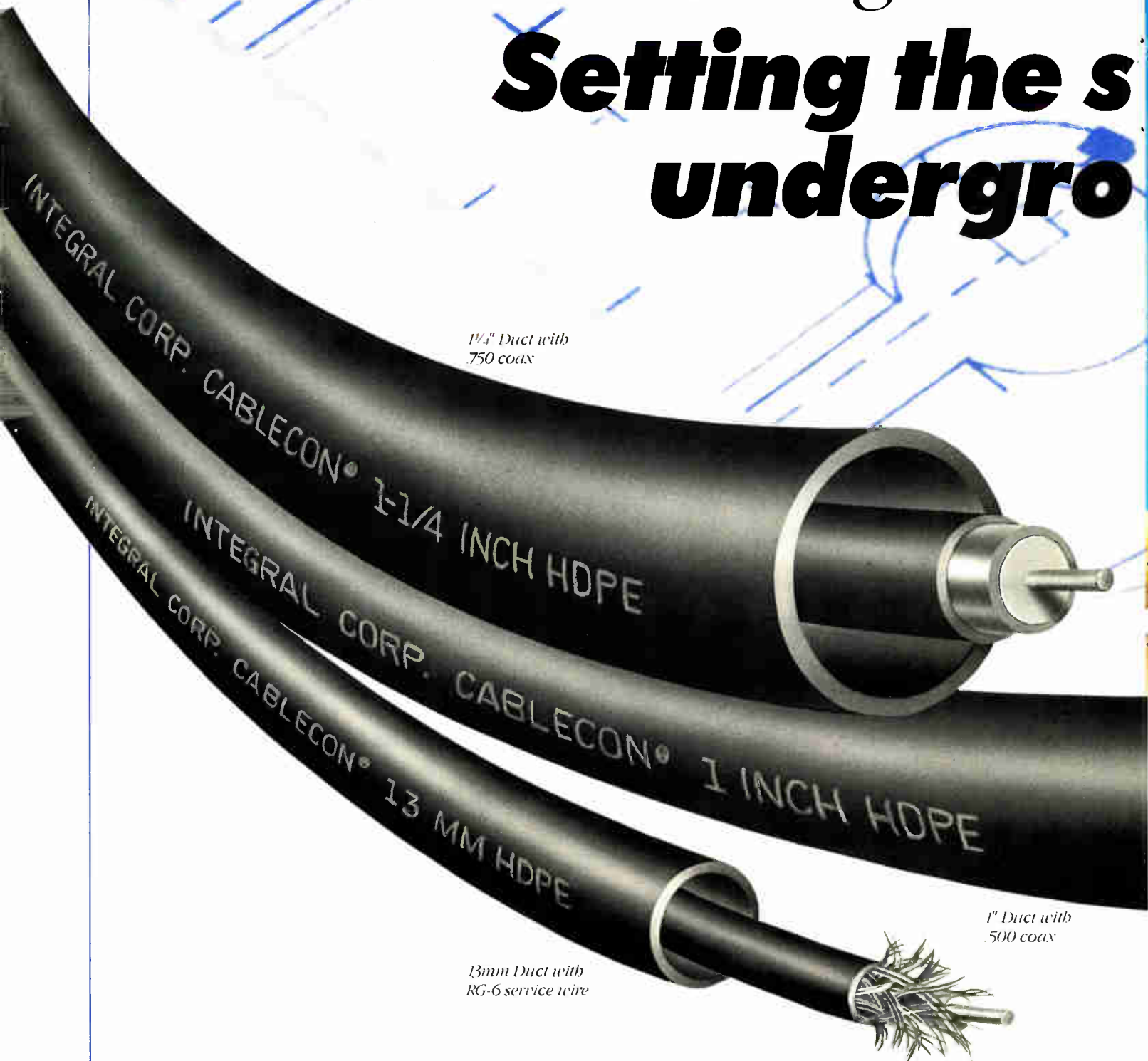

*1" Duct with  
.500 coax*

*13mm Duct with  
RG-6 service wire*

See us at NCTA, Booth 1423.

 **Integral  
Corporation**

**MARKETED EXCLUSIVELY BY**

Channell Commercial Corporation

**800/423-1863**

**800/345-3624**

**in CA**





# Channell... **standards for underground plant.**

Integral and Channell have been setting industry standards together for over 8 years. Our association has made us the leaders in providing underground materials for Cable Television plant: Integral's Cablecon® Cable-in-Conduit (CIC),

Drop-in-Duct (DID), and Fiber-in-Duct (FID); and

Channell's free-breathing above grade pedestals and airtight, watertight below grade enclosures.

To make it easier to order our complete line of high quality CATV products and to increase your construction efficiency, we would like to send you our new designer template — **FREE!** It contains all of the

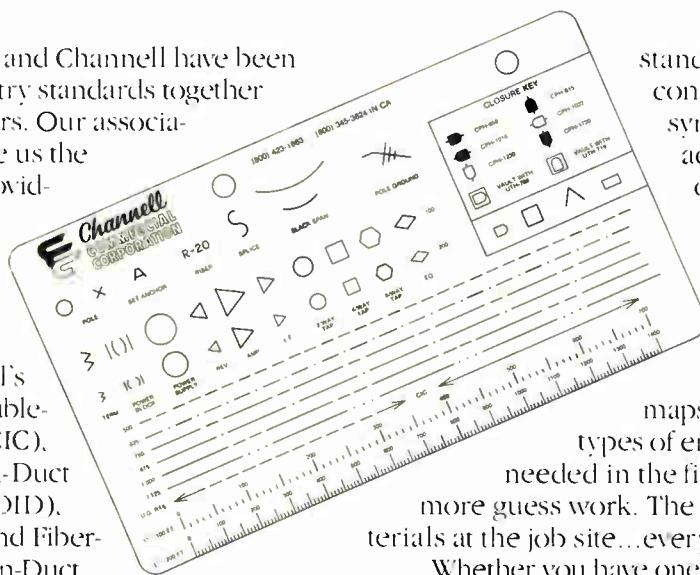

standard construction symbols adopted by our industry, plus new symbols that allow you to show on your base maps the exact types of enclosures needed in the field. No

more guess work. The correct materials at the job site...every time!

Whether you have one mile or a 100 miles of underground plant to build this year, why not buy direct from the Integral and Channell team? You'll save big bucks and be supported by one of the industry's largest direct sales forces in the U.S. and Canada.

Put our high standards to work for you today. Call **800/423-1863 (800/345-3624 in CA)**, or write for your **FREE** designer template and information on the complete line of Integral's Cable-in-Conduit products and Channell's above and below grade pedestals and enclosures.

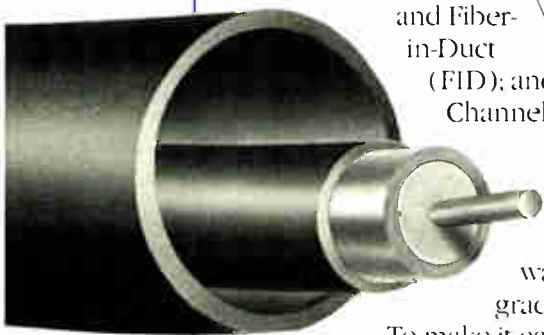

**Channell**  
**COMMERCIAL**  
**CORPORATION**



## Much ado about nothing?

On the surface, it seems like a reasonable request. But deeper investigation uncovers the reasons *why* MMDS operators (who prefer to be called "wireless cable operators") cannot be considered equals with their more traditional hard-cable brethren.

In case you haven't heard the cacophony already, wireless operators have been squawking long and loud about the poor treatment they feel they receive from programmers. They say that if they could just get equal access to services like Home Box Office, Showtime, ESPN and others at reasonable rates, the MMDS marketplace would take off like a rocket to the moon. This unlevel playing field, they argue, is locking out a viable alternative medium from viewers' homes.

But as you'll read in Managing Editor Kathy Berlin's story beginning on page 46, the issue is more complicated than that. Uncertain security, fly-by-night operators and signal quality concerns all impact severely on wireless cable's viability. There's no magic here; if programmers believed they could increase their annual revenues by increasing the number of MMDS affiliates, they'd do so; and, in fact, responsible wireless operators *are* being served.

But, intertwined within all the sour-grapes grousing, lies a bit of truth. Wireless cable has its place and its application. Instead of simply casting the technology aside, cable operators should give the technology a second look and consider using it where it makes sense. Just like fiber optics, MMDS should be considered another "tool in the toolbox" available for cable operators who want to extend systems into areas that are presently underserved by coax.

The technology isn't appropriate everywhere. Because MMDS depends on line-of-sight, mountainous areas or dense urban areas with numerous high-rise buildings can't be properly served, due to reflections and signal interruptions. But if you're an operator who'd like to extend your plant out to some rural areas to gain new subscribers, give MMDS thorough consideration.

After some investigation, operators will find wireless cable has low start-up costs, but is plagued with high operating costs. And the in-home converter equipment is expensive.

Nevertheless, smart cable operators can turn a potential competitor into an opportunity by embracing the technology, if it's merited. And, in the course of good business, another lingering concern could be eliminated; government officials, who have been alerted to the alleged "inequities" by the Wireless Cable Association, could be placated if they are shown cable operators are doing everything in their power to extend their services to rural pockets of television viewers.

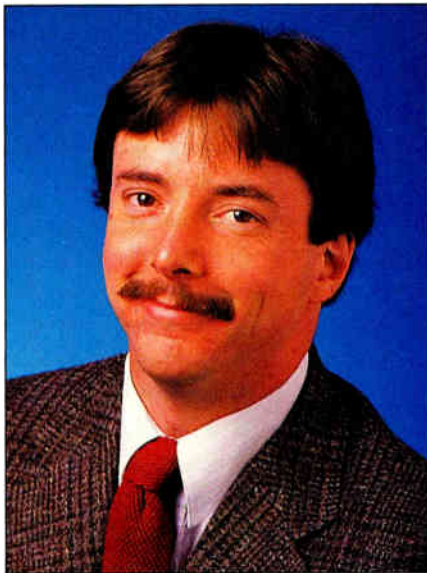

Roger Brown  
Editor

*Roger J. Brown*

**William McGorry**, Group Publisher  
**Robert C. Stuehrk**, Associate Publisher

**EDITORIAL**

**Roger Brown**  
Editor

**Kathy Berlin**  
Managing Editor

**Greg Packer**  
Contributing Editor

**George Sell**  
Contributing Editor

**CONSULTING ENGINEERS**

Chairman

**Wendell H. Bailey**, NCTA VP, Science and Technology

Members

**Jim Chiddix**, Senior VP, Engineering and Technology, ATC

**John Dawson**, Engineering Consultant

**Roy Ehman**, Director of Engineering, Jones Intercable

**Tom Elliot**, Director of Research and Development, Tele-Communications Inc.

**Jim Farmer**, Principal Engineer, Scientific-Atlanta

**Paul Helmbach**, VP Engineering, Home Box Office

**Fred Kaiser**, President, Alpha Technologies

**Dave Large**, Director, Video Product Planning, Raynet Inc.

**Robert Luff**, VP Technology, Jones Intercable

**Steve Raimondi**, VP Engineering, UA Cablesystems Corp.

**Joe Van Loan**, Engineering Consultant

**PRODUCTION**

**Jeff Knight**, Production Director

**Don Ruth**, Art Director

**Elaine Callahan**, Production Manager

**Dick Benson**, Circulation Director

**ADVERTISING**

**Cathy Wilson**, National Sales Manager

**Judy Medley**, Account Executive

**Curt Stocker**, Classified Sales Manager

**MARKETING AND SUPPORT**

**Michelle Pazar**, Author Support and Quality Assurance

**Linda Hendrick**, SCTE Chapter Support

**OFFICE**

Denver 600 S. Cherry Street, Suite 400, Denver, CO 80222 (303) 393-7449. Fax (303) 393-6654.

**ITCI**

INTERNATIONAL THOMSON  
COMMUNICATIONS INC.





**We're out to convert the cable industry.**

**Panasonic's new TZ-PC 140/170 series cable converters carry the industry's first 5-year warranty.**

Reliability. It's what you demand from CATV converters. It's how you avoid costly service calls and replacements. It's what you expect from Panasonic.

Now, Panasonic, the industry's leader, proudly unveils a new standard in reliability: the new PC 140 and 170 series cable converters. And we're backing them up with an unprecedented 5-year warranty.

That 5-year warranty covers a high-performance package: 550-MHz/85-channel, phase-locked synthesizer circuitry, an all-function, wireless remote, built-in BTSC stereo-compatibility and Up-Down Channel Scan. Plus Sleep Timer, a Parental Guidance Control option and more.

For product or dealer information, call (201) 392-4709. Panasonic's new PC 140/170 series cable converters: the means to end-user satisfaction.



**Panasonic**  
**CATV Products**





David L. Willis

### Quality, continuity still the keys

After spending four years in the Air Force—a year in electronics school and three years serving as in-flight radar maintenance—what's the logical thing to do once you're out? Try to find a job, of course.

Back in 1955, that's exactly the situation Dave Willis, now the director of engineering for Tele-Communications Inc. (TCI), found himself faced with. He was bored with Moses Lake, Wash. where he worked for Boeing for a brief period, and he wanted to move back to Sidney, Neb., where he was born and reared.

#### Learning by doing

While looking for a job in his hometown, Willis met Everett Collier of Collier Electric Co. of Denver, who was planning to build a cable system. Willis asked for a job and, after laying out the plans, Collier showed Willis what he wanted—and left. Willis began constructing that system, using strip amps at the headend and a 750-foot tower, in August and was essentially finished doing installs by December. Penetration by the end of the year was almost 100 percent as nearly 1,500 of the 1,500 to 1,600 homes in Sidney signed up for the service.

The success of the system may seem extraordinary, but in those days, viewers didn't have much choice. "It was

an absolute, historic type of system," says Willis. "Before we put cable in, you could have a very nice rooftop antenna and you might get reception of some kind, pretty bad usually, for 45 minutes to an hour a day in the late evening. There simply was no other way to get the picture except by cable."

In 1962, Willis was the technician in charge of all systems when Community TV of Boseman, Mont. acquired Collier Electric. Shortly thereafter, the company began to evolve into what is now known as TCI and, in the late '60s, moved to Denver. Jerry Shield, chief engineer for TCI at the time, invited Willis to join his staff and Willis moved to Denver in 1969 to become part of the corporate engineering staff. Two years later Willis was made director of engineering, a position he's held for the past 18 years.

#### Not many changes

Willis, who oversees the engineering, technical purchasing and training for the industry's largest MSO, doesn't see his role as having changed that much over the years. When Willis was initially promoted to director, TCI did its own system development and design. Now, with the exception of line extensions, most of TCI's system design is done by equipment vendors. "Other than getting away from doing the design," says Willis, "the jobs and the roles haven't changed that much."

However, the technology is another story. "The real revolution in cable came when satellite transmission came in," says Willis. "That was a tremendous turnabout for the whole industry." Crediting advanced technologies and better television sets, Willis believes the industry is not only delivering better pictures but is delivering more consistency. Quoting a former boss, Willis' favorite saying is, "we are responsible for the quality and continuity of the signal quality delivered to the subscriber."

#### Fairly good, fairly bad

"I think that's a great, great thought," says Willis. "And it's very accurate about what engineering and technical departments do. I think it's the whole story, and we do a much better job of it today than we ever have." However, Willis also sees areas where the industry could do better.

"For every system out there that's delivering great, grade-A pictures, you've got other systems that are doing a fairly bad job. I think the industry needs to try and reach those qualities that you can find occasionally but you can't find all the time."

Unfortunately, even those systems that are doing a bad job have faithful viewers. Willis firmly believes it's the content of the picture that is vastly more important than the quality. Which is why he sees HDTV as a lot of hyperbole and more of a political issue than a technical one.

Willis is also less zealous than others about expanded bandwidth for future applications. "I'm very much against it," says Willis. "Whether it be per channel or per system. It seems to me that each time we do one of these big steps, we introduce so much more complexity into the system, and so many more problems, that there is a point of diminishing returns."

#### High quality of personnel

The developing technologies and their possible limitations haven't dampened Willis' enthusiasm for the technical community in the cable industry. Compared to the situation in 1955, when everything was new, "virtually no one understood anything," says Willis. "I think the quality of the engineers has improved dramatically. You have a lot of guys around now who are very sharp, technical people that you saw very few of before."

Still, Willis throws a challenge to those same technical engineers. The engineering community must often comply with a new rule or regulation. Instead of accepting the challenge of compliance, Willis feels the engineers should be "critical of what that challenge is and ask if it makes sense. Instead of asking 'how can we comply with this?,' they should ask 'why do they want to do this?'" says Willis.

With a firm hand in the training of technicians for TCI and as a board member for the Society of Cable Television Engineers (SCTE), Willis is in a good position to convey those ideas. Future technicians and engineers may question not only compliance, but underlying incentives for new technology. Until then, there's always more cable systems to build, and this time Willis is armed with infinitely more knowledge—and experience. ■

—Kathy Berlin





## NO DROPOUTS

Now that Trilogy has a complete line of foam drop cables, you don't have to go elsewhere to move inside after your MC<sup>2</sup> trunk and feeders are in place.

And you get the savings of one-stop

shopping in all installations.

Take it all the way in with Trilogy and go forward with confidence with the most rigorous quality control found in the industry.



### Trilogy

COMMUNICATIONS INC.

Call or write for our free sample and brochure: TRILOGY COMMUNICATIONS INC., 2910 Highway 80 East, Pearl, Mississippi 39208  
800-874-5649 • 601-932-4461 • 201-462-8700

Reader Service Number 4





## Great nights every night

My comments this month will be a little unusual for inclusion in a technical journal. However, I would like to point out (with some pride) that cable has just completed the annual promotional campaign called Cable Month (April), subtitled "Thirty Days of Great Nights."

Being involved with the NCTA, I've had many occasions to see the promos, the special programs and the documentaries. I've heard all of the self-promotion and puffery and hyperbole associated with any monthly celebration of an industry's creativity.

What I must say is that I believe that most of the puffery and hyperbole I've heard is actually warranted. The programming I've seen and the efforts I continue to see by the creative community have been very, very good. It was not always thus.

### Getting better

There was a time not so many years ago when the industry was hard pressed to roll out something it had created and point to it with pride. What we now seem to have, if not exactly a plethora of excellent programming, is a pretty large chunk of the stuff. I'm not talking just about the big national services such as HBO—which has taken justifi-

*By Wendell Bailey, Vice President  
Science and Technology, NCTA*

able pride in the many accolades it has received from both the cable and broadcast industry for its excellence in programming—but all of the nationals and other pay services such as Showtime, The Movie Channel, A&E, Discovery and Disney.

The local programming, called local origination and/or public access, also continues to be a source of special pride for the cable industry. When you look at this programming, you must bear in mind its intended audience. By its very nature, local programming and public access programming is intended for a town, community or specific region.

### Cable does it best

Therefore, the topics of this programming tends toward subject matter that does not travel well on a national basis. However, the award winning materials produced by local origination and public access stations does what cable does best—it serves the community where it lives.

This is good for the industry as a whole because the programming is clearly what consumers and subscrib-

ers like most about cable. This brings me to the second part of what I'd like to talk about. How many of you make an effort to train your customer service representatives, both those in the office and those that go into customer's homes, about the many offerings that your program suppliers provide to you?

instance, that C-SPAN is a chance to watch government in action—unedited, uncommented upon, and simply as is?

When a customer wants to know whether Nickelodeon is really good for their kids, would a cable installer say that, not only is Nickelodeon good, but mention some of the other programming that's available to kids, such as HBO's efforts aimed specifically at children and the Faery Tale Theater from Showtime?

I have actually seen companies who train their installers very carefully in these areas. They update installers on a weekly basis about big events coming up and provide useful materials to pitch the company's products. I've had friends who recently hooked up to cable tell me both stories—one in which they've asked the installer questions about different channels and received little response and other friends whose faces lit up as they praised the installer for his knowledge about cable programming.

### Knowledge is good

As engineers and technicians, we

'Congratulations are due to the cable industry's programmers, not just for 30 days of great nights, but for 365 days of choice programming. That's what cable and service to subscribers is all about.'

ers like most about cable. This brings me to the second part of what I'd like to talk about. How many of you make an effort to train your customer service representatives, both those in the office and those that go into customer's homes, about the many offerings that your program suppliers provide to you?

### What's on cable?

How many CSRs can answer customer's questions about what's on cable this week? How many can answer a customer when they say "What's this C-SPAN thing?" (A service that will be remembered in the future as one of the most significant informational services any industry has provided to the American people.) Would they say, for

don't have much say about the creativity that goes into the programmer's mix. But as people who provide service and have direct contact with the customers, we can and should be knowledgeable about the programming the cable industry offers. In addition to doing a good job of hooking up the customer and keeping their entertainment center working properly, we should see to it that when they ask questions, they get knowledgeable and enthusiastic replies.

Congratulations are due to the cable industry's programmers, not just for 30 days of great nights, but for 365 days of choice programming. That's what cable and service to subscribers is all about. ■



# Six VideoCiphers<sup>®</sup> and Receivers in only 15 inches



Whether you are building new headends or adding scrambled channels, the Nexus VCMB and Nexus Satellite Receivers offer you a unique solution to rack more channels in less space. Contact us for more details.

All Nexus Headend products are covered by the famous Nexus 5 Year Warranty. Videocipher® Modules covered by General Instrument's warranty.

**Nexus — Definitely Ahead of Our Time**

Tel: (206) 644-2371 Bellevue, WA. or (604) 420-5322 Burnaby, BC. Fax: (604) 420-5941  
Write: NEXUS ENGINEERING CORP., 7000 Lougheed Hwy., Burnaby, BC. V5A 4K4

**NEXUS**  
**ENGINEERING CORP.**  
**PERFORMANCE**  
**YOU CAN SEE.**

*rely on*





## Optical vs. electrical power

The world of fiber optics is upon us, and many are amazed at how quickly the industry is beginning to embrace this new tool. Since the technology is relatively new to the CATV industry, however, many individuals have put themselves into a "learning mode," trying to gain as much practical knowledge as quickly as they can so that they too can begin to use the technology in their applications and architectures.

During this learning phase, many have found that, while fiber optics distribution is no more difficult to understand than conventional coaxial distribution (after all, light is simply extremely high frequency RF), it does require that we re-examine some of our more traditional thought processes; glass vs. copper, kilometers vs. miles, and nanometers vs. MHz, to name a few. But certainly we needn't worry too much about the simple rules we've learned as electrical engineers because a dB is a dB is a dB....right? Well, as we shall see, when comparing electronics and optics, this isn't necessarily the case.

### 2-to-1 difference

One thing you will recognize very quickly as you begin your study of

*By Chris Bowick, Director of Engineering, Headend and Earth Station Products, Scientific-Atlanta*

optics, is that there is a 2-to-1 difference (in dB) between the definitions of electrical power-gain (or loss), and that of optical power-gain (or loss) through a fiber optics network. That is to say, every dB of optical power gained or lost in a network translates into 2 dB of electrical power gained or lost.

Traditionally, based on Ohm's Law, the electrical power being dissipated in a load resistance can be easily calculated based on a measurement of either a voltage across a known load resistance, a current through a known load resistance, or alternately by measuring both the current through and the voltage across a load resistance. These relationships can be expressed mathematically as follows:

$$P = E^2/R \text{ (Equation 1)}$$

$$P = I^2 * R \text{ (Equation 2)}$$

$$P = E * I \text{ (Equation 3)}$$

### Converting to dB

If we wish to determine the electrical power gain or attenuation in dB between any two points in a system, we can express this as a simple logarithmic ratio of these parameters as measured at those two points in the system. For example:

$$\text{Electrical Loss} = -10 \log (P_2/P_1) \quad (4)$$

Substituting Equations 1 and 2 for  $P_2$  and  $P_1$  above we have:

$$\text{Electrical Loss} = -10 \log \left( \frac{E_2^2/R_2}{E_1^2/R_1} \right) \quad (5)$$

or,

$$= -10 \log \left( \frac{I_2^2 * R_2}{I_1^2 * R_1} \right) \quad (6)$$

For purposes of this discussion, we'll limit ourselves to a discussion and further simplification of only Equation 6. If  $R_1$  and  $R_2$  are equal, this equation can be further simplified to:

$$\text{Electrical Loss} = -10 \log (I_2^2/I_1^2) \quad (7)$$

If we eliminate the square term by transferring it out of the log function, the equation becomes:

$$\text{Electrical Loss} = -20 \log (I_2/I_1) \quad (8)$$

Thus, the transfer of electrical power between any two points in a system can be seen as a "20 log" function of the difference in the electrical current between those two points, given two equal resistances.

### Optical comparison

Now let's shift gears to the optical domain for comparison. Optical power is simply a measure of the flow of photons (optical energy) per unit time. Eventually, if we are to use this energy, the optical power (photons) must somehow be converted back to electrical power (electrons) at the destination. The device that does this is called a photodetector or photodiode.

Semiconductor photodiodes like the PIN and avalanche photodiode absorb the incoming optical power (photons per unit time) from the fiber and produce an electric current (electrons) that is *directly proportional* to the optical power absorbed (See equations in references 1 and 2). Therefore, a reduction in the photodiode's absorbed optical power by 50 percent will result in a 50 percent reduction in the electrical current produced by the photodiode. Similarly, doubling the optical power will double the electrical current out of the photodiode. It is this linear input-output-power vs. electrical-output-current characteristic of the photodiode that creates the anomaly between optical power and electrical power.

Since, as described earlier in Equation 8, electrical power is a "20 log" function of electrical current, a 3 dB (50 percent) reduction in optical power into the photodiode which causes a 50 percent reduction in electrical current out of the photodiode, will result in a 6 dB (75 percent) reduction in electrical power out of the photodiode (Electrical Loss =  $-20 \log [0.5]$ , or 6 dB).

So be careful as you discuss optical link budgets, and optical dynamic ranges, because whatever power problems the optics might have (in dB), the electronics must deal with the same problem, only twofold. ■

### References

1. Lockwood, Larry. "Fiber Optics Insights," prepared for the SCTE. Corning Glass Works. 1988.
2. Gecheler, Siegfried, *Optical Fiber Transmission Systems*, Artech House, Inc., Mass. 1987.



# SAVE NOW, \$229 SAVE LATER. 87% EFFICIENT

## FR-6015-0 POWER SUPPLY

**VALUE.**  
Power Guard delivers highly efficient, top quality products at extremely competitive prices.

**VALUE.**  
Accepts modular options.

**VALUE.**  
87% maximum efficiency; true 15 amp design

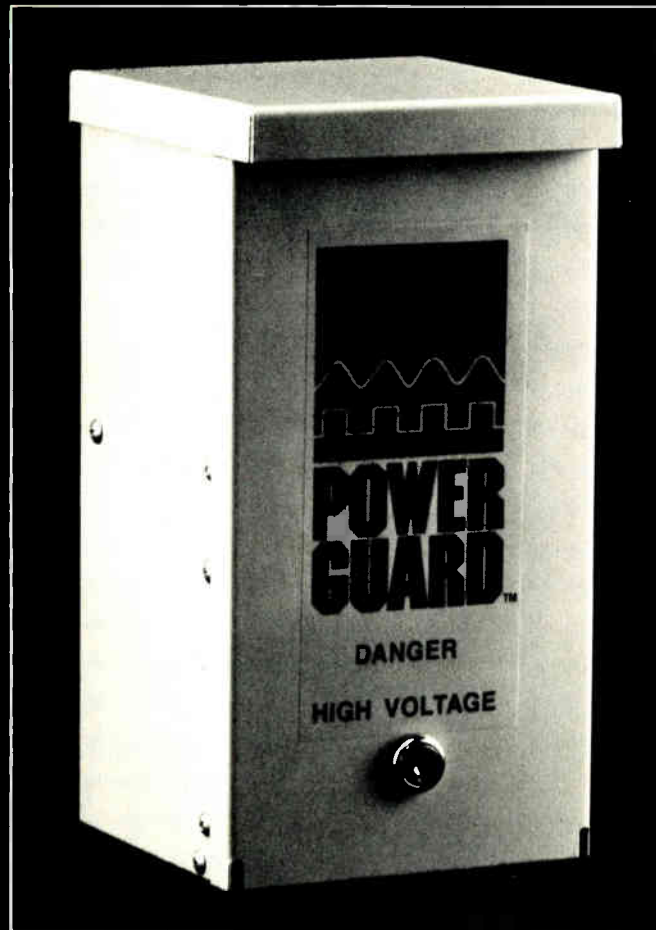

**VALUE.**  
Compact size (11½"H x 6"D x 6"W).

**VALUE.**  
Special 2 year warranty.\*

**VALUE.**  
Power Guard is 100% committed to customer satisfaction.

**CALL 1-800-288-1507 FOR ADDITIONAL INFORMATION.**

 **POWER GUARD**

801 FOX TRAIL • P.O. BOX 2796  
OPELIKA, ALABAMA 36801  
1-800-288-1507 • (205) 742-0055

**IN STOCK AT MIDWEST CATV.**





### What is a cable system?

The Cable Communications Policy Act of 1984 confirmed the authority of state and local governments to require cable systems to obtain franchises and to impose certain requirements on such franchised systems. Indeed, all new cable systems are now *required* to obtain franchises.

But just what is a "cable system," for purposes of all these requirements? Exactly what the Act's definition of a cable system encompasses has been a matter of some dispute during the last four years, and is currently the subject of an FCC rulemaking proceeding.

#### Exception to the rule

The Act defines a "cable system" as a "facility, consisting of a set of closed transmission paths and associated signal generation, reception, and control equipment that is designed to provide cable service which includes video programming and which is provided to multiple subscribers within a community." There is an exception, however, for facilities that serve "one or more multiple unit dwellings under common ownership, control, or management, unless such facility...uses any public right-of-way."

This exception clearly applies to a SMATV system that serves a single,

*By Michael Schooler, Deputy General Counsel, NCTA*

multiple unit apartment building. But it's not been entirely clear whether any other pay television systems are exempt from the requirements that the Act imposes on cable systems.

Part of the confusion stems from some unfortunate language in the FCC's order in 1985 changing its own definition of a "cable system" to conform to the new statutory definition. At that time, the FCC stated that with respect to facilities serving multiple unit dwellings, "we will include as cable systems only such facilities that use public rights-of-way." This language suggested that a system serving several multiple unit dwellings in a private real estate development, such as a private resort community, would never be deemed a cable system for purposes of the Cable Act. But this was clearly wrong. The FCC now recognizes that unless all the multiple unit dwellings served by the facilities are under common ownership, control or management, the facility is a cable system, regardless of whether it crosses public rights-of-way.

Moreover, in focusing solely on whether public rights-of-way were used, some systems serving private developments forgot that the exception only applied to systems serving multiple unit dwellings.

#### Definition fuzzy

Even where a system serves only multiple unit dwellings under common ownership, management or control, it's not entirely clear when or whether the system is using public rights-of-way. The Act does not define "public rights-of-ways," and while some SMATV operators may assume that the term applies only to streets, land and easements that are owned by the local government, this is not necessarily the case. Even where a community is built wholly on private property, the parks, roads and thoroughfares of that community have been deemed "public" or at least "quasi-public" for some governmental and regulatory purposes.

While Congress obviously meant to exempt systems serving two or three commonly owned apartment buildings on a private parcel of land, it's not at all obvious that a system that crossed roads, sidewalks and parties in a "private" resort community would not be deemed to be using rights-of-way that, for purposes of the Act, are "public."

Wholly apart from the exception for multiple unit dwellings, there is some uncertainty as to whether the Act's definition of a cable system was meant to extend only to traditional wired coaxial (or fiber) systems, or whether it also covers wireless transmission systems like MMDS and DBS. While many assumed that the Cable Act was aimed at traditional cable systems, two courts have recently read the Act's definition of a cable system more expansively.

#### Microwave a closed system?

Thus, a federal district court in Fargo, N.D., ruled last year that a system that delivered video programming by infrared transmissions to several multiple unit dwellings not under common ownership was a cable system. In the court's view, the infrared delivery system constituted the "set of closed transmission paths" that, under the Cable Act, made it a cable system.

Another federal court in Atlanta held that a company that retransmitted scrambled programming by satellite to backyard dishes (TVROs) was also a cable system under the Cable Act. Presumably, under this court's interpretation, virtually any pay TV system, however delivered, is a closed transmission system that qualifies as a cable system. The court, which was mainly addressing copyright issues, did not describe precisely how DBS systems would be franchised and subjected to access, franchise fees and other requirements.

#### More or less unambiguous

The FCC now realizes that the statutory definition of a cable system may not be quite as unambiguous as it thought when it adopted its rules implementing the Cable Act in 1985. It now recognizes, contrary to its earlier view, that SMATVs serving several buildings will often be cable systems even if they do not cross public rights-of-way. But it is skeptical that Congress meant to treat MMDS, DBS and other systems that deliver video programming through wireless transmissions as cable systems. So, it has initiated a rulemaking proceeding in which, after reviewing comments of interested parties, it will revise its rules to clarify more precisely what is and is not to be deemed a cable system under the Cable Act. ■



*the*

**SOURCE**

**Take your signal from Sony.**



Sony's FSR-1100 satellite video receiver delivers a clear signal you can depend on. For CATV, SMATV, broadcast or business television, the FSR-1100 is the most reliable, flexible, high performance commercial satellite receiver available for the money.

Whether you're operating on the Ku or C band, Sony's FSR-1100 receiver provides the superior video and audio reception viewers expect. The FSR-1100's unique adjustable detector bandwidth allows quality reception even under adverse signal conditions. And its advanced operating features make it easy to use.

When you choose the FSR-1100 you're choosing Sony quality. Sony's unsurpassed experience and commitment to excellence in professional broadcast and industrial video equipment coupled with Midwest's outstanding support and service make a winning combination that can't be beat. Get the picture? You will if you take your signal from Sony.

For more information about the Sony FSR-1100, call one of our sales representatives today.

**SONY**® is a trademark of Sony.



**MIDWEST**  
Communications Corp.

One Sperti Drive  
Edgewood, KY 41017

**1-800-543-1584**

In Kentucky, 606-331-8990



# Inside a CATV amplifier

**W**hile most CATV technicians are fully familiar with amplifiers, and deal with them on a daily basis, few are aware of the design challenges faced by the manufacturer in providing a workable product. It is, however, possible to compromise the overall performance of an amplifier through misalignment and mishandling. The best defense against this possibility is to gain an insight as to what goes on under the cover, and why.

## Common structures

All CATV amplifiers are built up from a selection of basic circuit assemblies. These are: Gain blocks; equalizers; attenuators; filters; control circuits; and mechanical power supplies.

These circuit assemblies are concerned with three basic functions:

The gain block amplifies the signals; equalizers, attenuators, control circuits and filters maintain the gain block operating within its RF performance envelope; and mechanical power supplies maintain the gain block operating within its power, temperature and environmental envelope.

**Definitions:** The gain block consists of either a discrete amplifier stage or a hybrid integrated circuit amplifier.

The RF performance envelope of the gain block is the operating area defined by the minimum input, maximum output, channel loading and distortion handling capabilities.

The environmental and power envelope of the gain block is defined by the maximum safe operating voltage, minimum operating voltage, current requirement and safe operating temperature of the transistor dies.

An example of the RF envelope of a gain block is illustrated in Figure 1, while Figure 2 illustrates an example of the power/temperature/distortion envelope of the transistor die.

## Flexibility is key

The primary concern of the manufacturer is to build an amplifier which

*By Karl Poirier, VP Corporate Development, Triple Crown Electronics  
Originally published in Cable Communications Magazine, Canada*

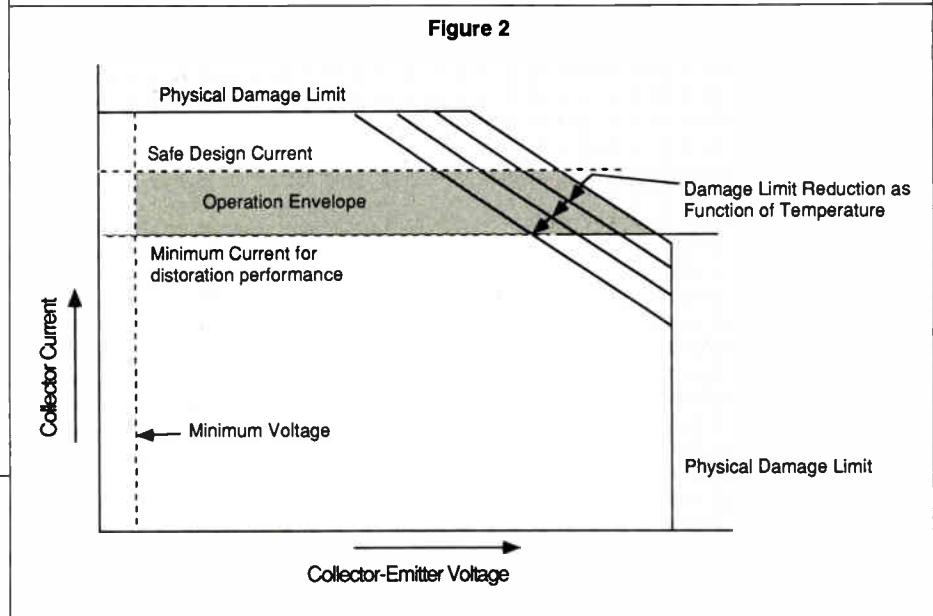
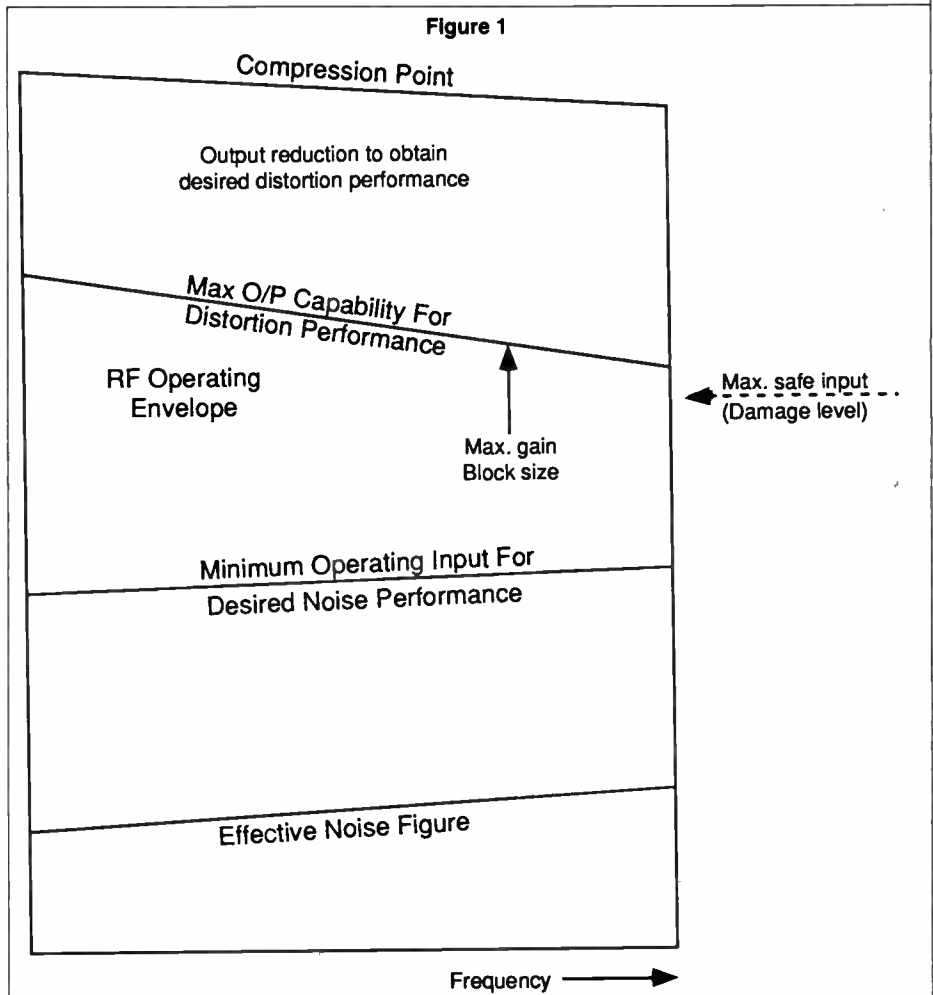





## Wouldn't it be nice if C-COR rebuilt homes, too?

Like our cable system rebuilds, you'd have the technology of tomorrow, today. And if you preferred, we'd custom build it. Your warranty would be three times the industry standard. You could reach us 24 hours a day for personalized service and fast turnaround on repairs.

You'd have the best home on the block.

If this kind of innovative service, advanced product line and commitment to quality hits home, let us show you what we can do for your business. Call 1-800-233-2267. In PA, 1-800-356-5090. Or write: C-COR,

Reader Service Number 8

60 Decibel Road, State College, PA 16801.

But please. Limit your rebuild requests to cable systems. We don't do houses. Yet.

**C-COR**<sup>®</sup>  
ELECTRONICS INC

We're Out To Give You  
The Best Reception In The Industry.

## AMPLIFIERS

allows the gain blocks to operate over the widest possible range of applications while staying at all times within these envelopes. This is normally approached in two distinct methods:

- The operation within the power/temperature/distortion envelope is con-

design concept is to review the performance of a typical amplifier. Figure 3 is a representation of a generic amplifier commonly available from most manufacturers.

The amplifier consists of input and output test points and diplex filters,

area of the performance envelope will generate identical noise and distortion degradation.

In order to not see the distortion and noise contribution of two amplifiers from the typical amplifier stations, it is necessary that we operate the gain

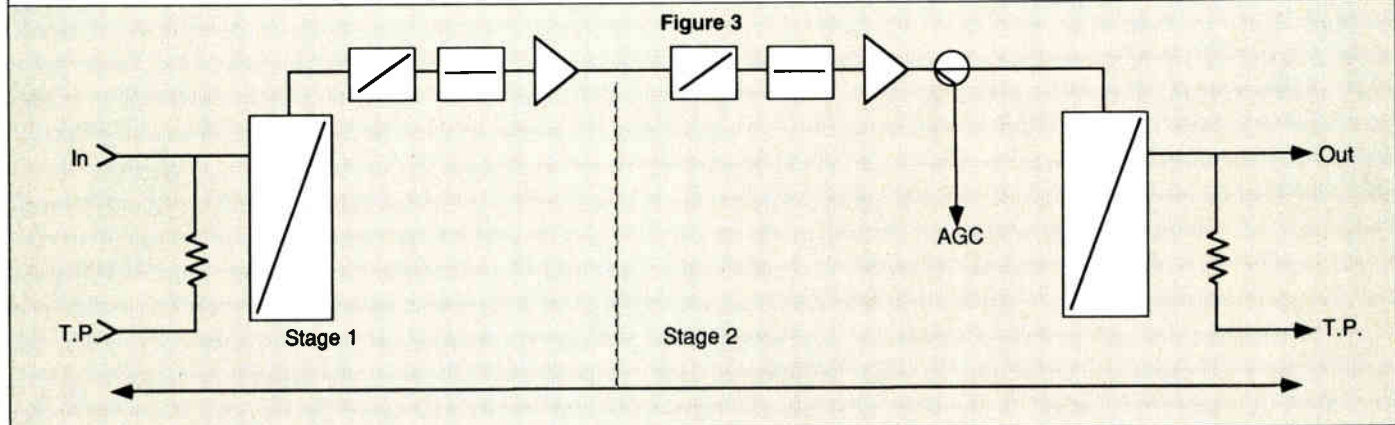

trolled through power supply and heat transfer design.

- Operation within the RF performance envelope is much more at the mercy of set-up errors.

The best way to understand the effects of the alignment procedure and

two gain blocks, and two sets (input and interstage) of level and slope adjustments. It is important to note that this is in fact two amplifiers in cascade, which brings us to a major potential problem. Two identical gain blocks, operating in exactly the same

blocks as close as possible to opposite ends of the window. (See Figure 4.)

In this case, the distortion contribution of the input block is determined by the ratio 'A.' The greater this ratio, the less distortion generated by the input gain block. Likewise, the noise



### SINCE 1974, YOUR BEST BET FOR EQUIPMENT, SERVICE & REPAIR

HEADEND SERVICE • RECEIVERS • MODULATORS • PROCESSORS  
DISTRIBUTION REPAIRS TRUNK AMPLIFIERS • LINE EXTENDERS  
TEST EQUIPMENT SERVICE • CALIBRATION • REPAIR • UPGRADES  
FACTORY-TRAINED WARRANTY SERVICE • WAVETEK TEST EQUIPMENT  
ALPHA TECHNOLOGIES POWER SUPPLIES • CATEL HEADEND

*Quality Service, Affordable Prices, and a no-nonsense 90-day warranty!  
Emergency Repairs, Fast Turnaround our specialty--AT NO EXTRA CHARGE!*

#### CHECK OUR NEW EQUIPMENT PRICES BEFORE YOU BUY!

As authorized distributors, we can offer the most competitive pricing for:  
JERROLD • MAGNAVOX • VIDEOTEK • OLSON TECHNOLOGY • CADCO  
ALPHA TECHNOLOGIES (Non-standby Supplies) • M/A-COM • CATEL  
WIDEBAND ENGINEERING • COMETIC/DELHI • PICO/MACOM  
*WRECKING-OUT OR REBUILDING THIS SUMMER?*  
CALL NCS FOR THE BEST SALE PRICES OR TRADE-IN DISCOUNTS  
AGAINST YOUR NEW EQUIPMENT REQUIREMENTS!

NCS INDUSTRIES, Inc. 2255-E Wyandotte Road, Willow Grove PA 19090

**800-523-2342                      IN PA: 800-492-2032**

*BE SURE TO VISIT US AT SCTE, JUNE 16-18, ORLANDO:  
BOOTH #406-408.*

Reader Service Number 9

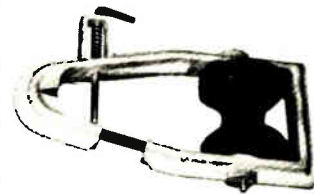

# Lemco

the  
tools  
of the  
trade

Call for your free  
catalogue.

**(800) 233-8713**

Reader Service Number 10



Over Thirty Years of  
**SERVICE,**  
**RELIABILITY**

and

**INNOVATION...**

- *the First 550MHz Apartment House Amplifier*
- *the First 700MHz Line Passives*

**NOW..**

*the* **FIRST**  
**650MHz**  
**DROP AMPLIFIER**



---

Frequency	45-650MHz
Gain	10dB
Noise Figure	4.5dB
CTB	-65dB
SP and UL Approved	

---

*Lindsay...Your Full Line*  
CATV Manufacturer ...  
*Actives at 550MHz,*  
*Passives at 700MHz,*  
*Apartment House Amplifiers and*  
*Ganged Apartment Taps,*  
*with a full line of*  
CATV Communication Antennas.

*Lindsay*

PA: TONER CABLE EQUIPMENT  
FL: INTERSTATE CABLE ENTERPRISES  
PA: JIM MORTON & ASSOCIATES

215-675-2053  
800-245-4423  
717-243-4653

MN: GRUNWALD, BURNS & ASSOCIATES 218-739-3961  
MT: KIP HAYES 406-752-5487  
CA: WESTERN CATV DISTRIBUTORS INC. 213-539-8030

---

**LINDSAY SPECIALTY PRODUCTS** 1248 Clairmont Rd, Suite 3D-231, Decatur, Georgia, U.S.A. 30030

Telephone: 404-633-2867

Fax: 404-634-1515

Head Office: 705-324-2196

---

## AMPLIFIERS

contribution of the output block is determined by ratio 'B.' Maximization of ratios A and B is the prime consideration in gain block size selection.

A second concern is the effect of build-in/build-out losses on the performance envelope. Build-in losses from test points, diplex filter, equalizer insertion loss etc. reduce the input

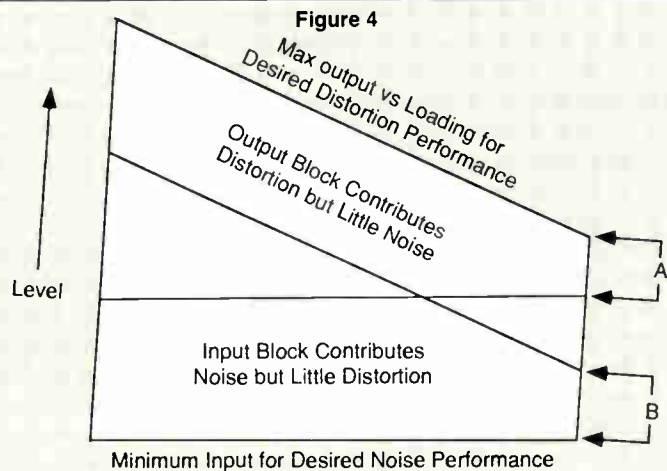

side of the envelope by the full loss amount, i.e. 2 dB build-in loss increases the minimum input level requirement by 2 dB. (See Figure 5.)

Likewise, build-out losses from test points, diplex filters, AGC couplers etc., reduce the output side of the envelope by the full amount.

Thus, when investigating the RF performance envelope, we must now consider the gain block as well as its associated input and output circuitry, as being an overall stage. We find then, in our typical two-stage amplifier, we are dealing with two basic sections, (Refer to Figure 3) including, input from amp station in to the first IC output; and output from first IC output to the station output.

In the case of our actual amplifier alignment, we are working toward two main objectives. They are: setting the

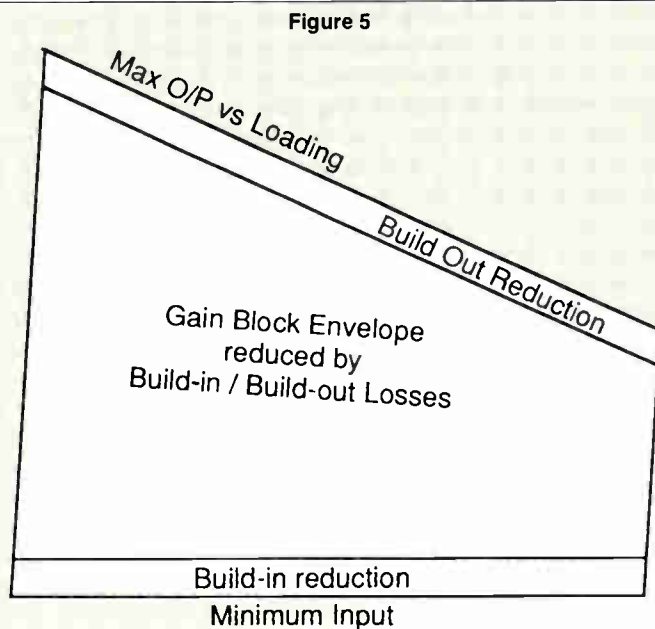

# WORKING

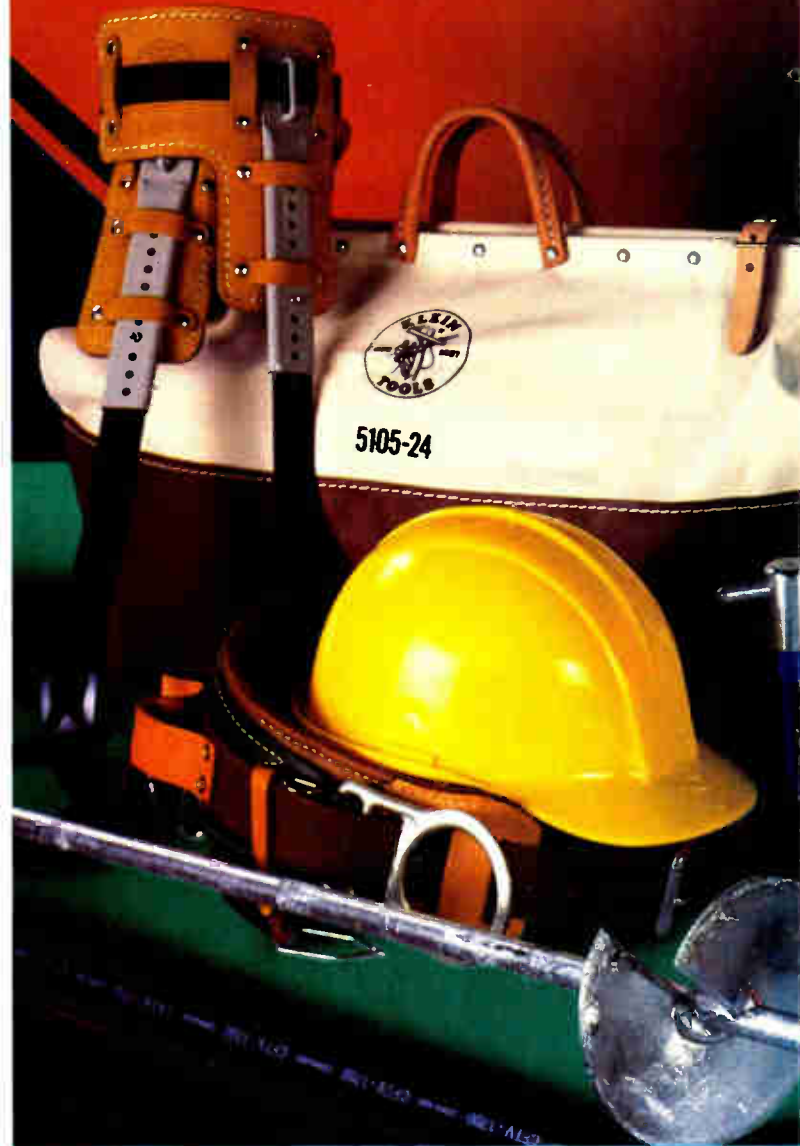

## Some suppliers could care less Next time, try MIDWEST

Need construction material? Now? No problem. We've got it.  
Pedestals. Hard hats. Screw anchors. Tool bags. Connectors.  
Sizing tools. Strand lashers. Coring tools. Gloves. Ground rods.  
Heat shrink. Safety cones. Lashing wire. Nuts. Bolts. And more!

Corporate Office  
Charleston, WV  
304 343-8874

Central Region  
Lafayette, IN 800 382-7526  
Outside IN 800 428-7596

Clarksburg, WV  
Outside





# less about your construction material needs. CATV. The supplier who gives a dam.

All from quality manufacturers and ready to ship nationwide.  
For quick service, call any of our offices today. Just tell 'em the Beav sent you.



A division of Midwest Corporation  
*More than supplies. Solutions.*  
Reader Service Number 12

**Eastern Region**  
WV 304 624-5459  
WV 800 532-2288

**Northeastern Region**  
Pottstown, PA 215 970-0200  
Outside PA 800 458-4524

**Southern Region**  
Ocala, FL 800 433-4720  
Outside FL 800 433-3765

**Southwestern Region**  
Dallas, TX 214 271-8811  
Outside TX 800 421-4334

**Western Region**  
Denver, CO 303 773-2205  
Outside CO 800 232-9378



# AMPLIFIERS

**Figure 6**

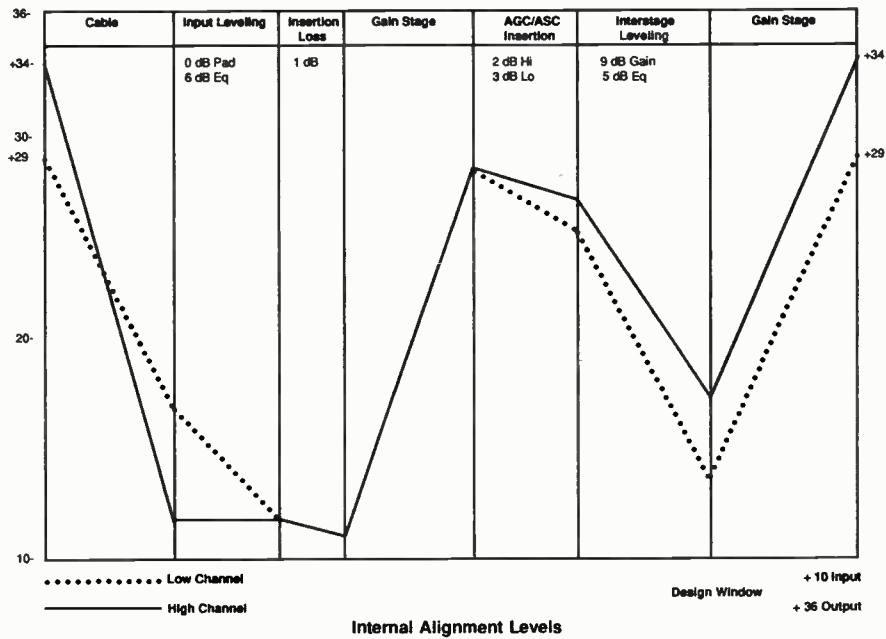

amplifier to make up for cable and passive losses on the input, and achieving this set-up while staying inside the RF performance envelope.

As the average amplifier has no interstage test capability, this second objective is easily compromised. In addition, the compromise is most likely to involve the low frequency channels, due to the normal slope reversal which takes place in the amplifier.

**Some examples**

In order to more clearly see this

effect, we will examine three different alignments of the same amplifier.

**Parameters:** Amplifier gain: 30 dB Max; Cable: 22 dB; Design output: +36 high, +29 low; Design input: +10 dBmV.

Figure 6 shows the typical amplifier in near optimum alignment. It can be noted that the low channel is a little lower in level than is desired, being only 3 dB above the noise design limit. This is due to the gain of the output stage, and, in fact, this situation could use a lower gain output block. This situation could easily be improved by

employing less forward slope on the system. This amplifier has been properly aligned using distributed slope correction, with the reverse slope equalized to flat in stage 1, and forward launch sloped in stage 2.

In Figure 7, the amplifier has been misaligned, with both the incoming reverse slope and the forward launch slope equalized in stage 1. In this alignment, the low channel has been reduced to 6 dB below the noise design limit. A system aligned in this manner would deliver a C/N (carrier-to-noise) ratio 7 dB worse than a system aligned

**Figure 7**

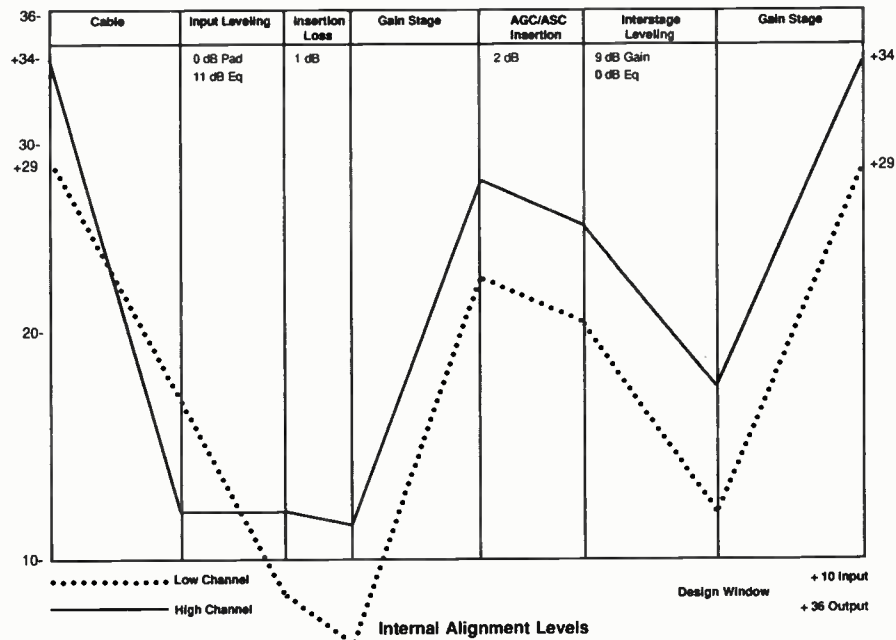



# REMEMBER THESE ADS?

**T**HEY FIRST RAN IN 1985. We brought them out again to remind you we've been talking about signal security for nearly five years.

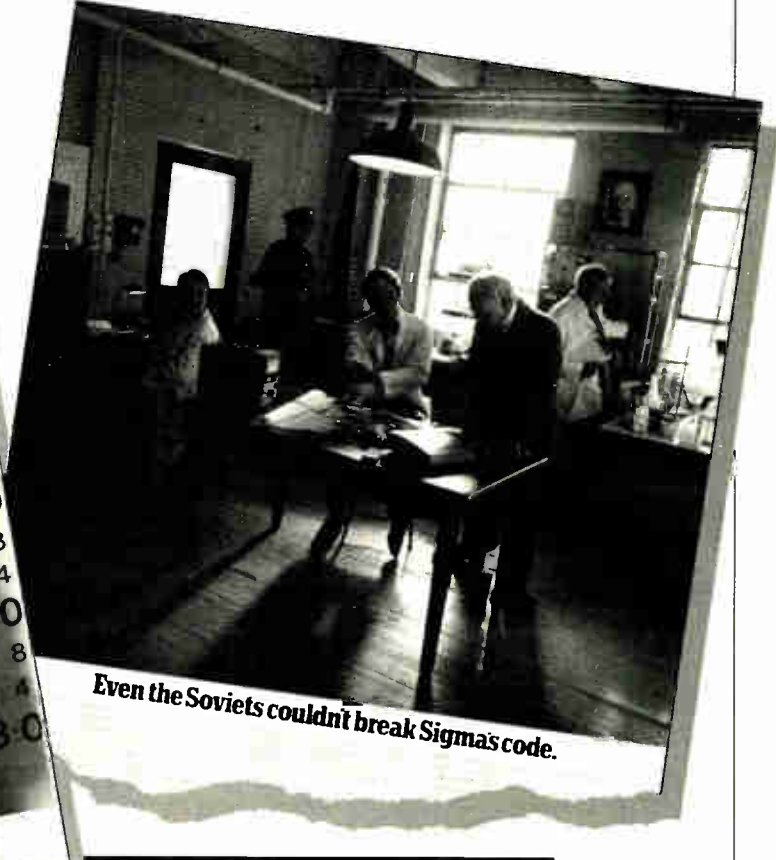

No other addressable system can protect your revenues like Oak Sigma. With over half a million units shipped, Sigma's encryption-based encoding has never been cracked. Never.

No other manufacturer of home cable (or satellite) security products can make that statement — not even for some of their "brand new" models.

Getting serious about signal security is just good business. Especially now that cable's most secure addressables

cost no more than some virtually defenseless systems. If you're making a multi-year security system investment, can you risk having anything less?

If you're ready to get serious about security, call us to arrange for a no-obligation demonstration of the toughest signal protection available — Oak Sigma.

**CDANK** Communications Inc.

16516 Via Esprillo • Rancho Bernardo, CA • 92127 • (619)451-1500

## AMPLIFIERS

as in Figure 6.

In Figure 8, the amplifier has been misaligned, with both the incoming reverse slope and the forward launch slope being equalized in stage 2 (interstage). In this situation the low chan-

nel output of stage 1 is 1.5 dB higher than the output of stage 2. A system aligned in this manner would deliver a distortion ratio 9 dB worse than a system aligned as in Figure 6.

Let me be so bold, however, to offer the following: The ideal alignment

through the use of a simple nomograph, which is described in the following section.

### Developing the nomograph

On any convenient size of graph or

**Figure 8**

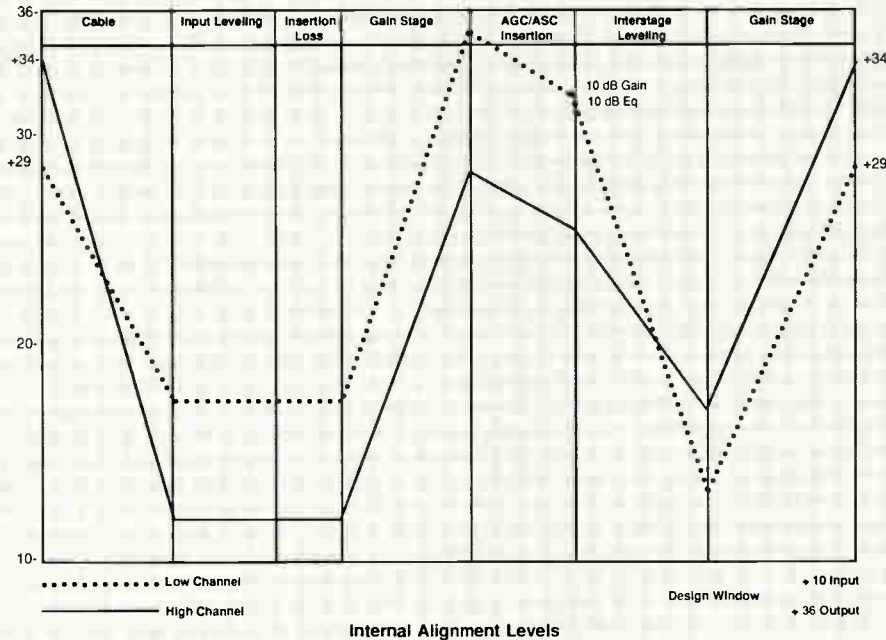

nel output of stage 1 is 1.5 dB higher than the output of stage 2. A system aligned in this manner would deliver a distortion ratio 9 dB worse than a system aligned as in Figure 6.

It should be noted, that all three alignments look identical when examined with signal level meter or sweep. All three alignments are 12/18 dB input and 34/29 dB output. In fact, nothing other than a level distribution

would exhibit the minimum differential level between low and high channels through stage 1, with launch slope induced in stage 2. And, the input level to the stage 1 gain block should be as high as necessary for noise performance, while remaining as close as possible to the low end of the RF performance envelope.

This alignment can be determined for any amplifier, cable and flat loss

grid paper, draw a horizontal line 40 units long. Number this line 0 to 40 dB left to right. This is the Gain/Attenuation axis.

From the 0 dB end of the Gain/Attenuation axis, draw a vertical line downward 10 units long. Number this line 0 to 10 dB, top to bottom. This is the Tilt axis.

From the 40 dB end of the Gain/Attenuation line, draw a vertical line

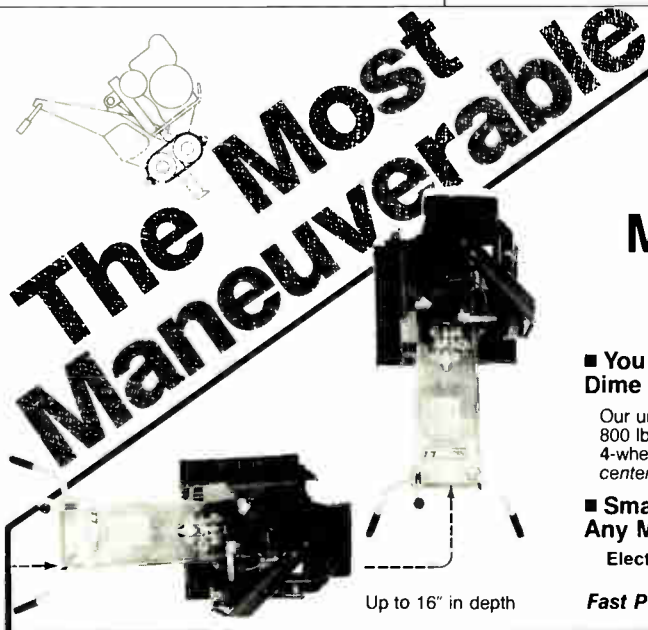

**Choose the Most Maneuverable Line Laying Machine on the Market. The Line-Ward L-2. Don't Settle For Less.**

- **You Can Literally Turn On A Dime**  
Our unique, patented design centers the 800 lb. total weight *directly over* the 4-wheel drive with the blade in the exact *center* of the machine.
- **Smallest Turning Radius Of Any Machine**  
Electric Start Optional
- Fast Parts Delivery & Service**

- **With Your Line-Ward, You Can Actually Make Right Angle Turns**
- Call For A Free On-Site Demonstration Or, Write For Our Free Color Brochure**

 Line-Ward Corp.  
157 Seneca Creek Road  
Buffalo, New York 14224  
(716) 675-7373



# AMPLIFIERS

Figure 9

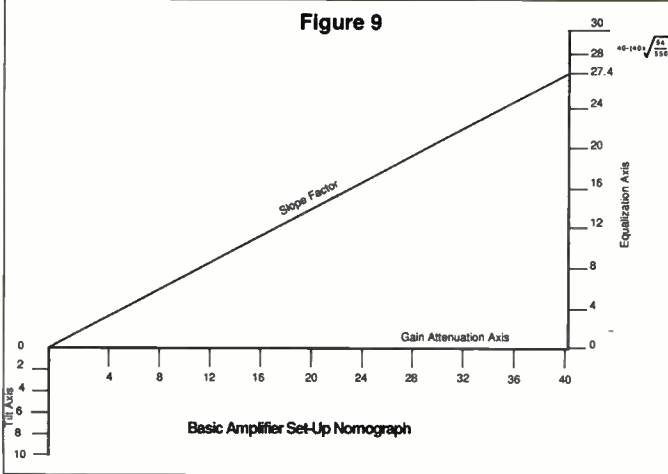

at 6 dB, then, draw a line from the 6 dB mark on tilt axis parallel to the slope factor axis to intersect the equalization axis at (in this example 27.4 dB - 6 dB = 21.4 dB) the

amplifier (10 dB).

Note: That portion of this required attenuation which is to the right of the noise limit mark must be performed in stage 2. In this case, 4 dB input attenuation and 6 dB interstage gain reduction. (See Figure 11.)

The point at which the vertical line from the cable loss point intersects the

extending 30 units upward. Number this line 0 to 30 dB, bottom to top. This is the equalization axis. (Make lots of photocopies, and you are ready to proceed. See Figure 9.)

Determine the alignment bandwidth of the system. This is the bandwidth to which you will set up, as opposed to the actual bandwidth of the equipment.

Using the following formula, determine the slope factor for this bandwidth.

$$40 - \left( 40 \times \sqrt{\frac{\text{Bottom Frequency}}{\text{Top Frequency}}} \right)$$

Example:

$$40 - \left( 40 \times \sqrt{\frac{54 \text{ MHz}}{550 \text{ MHz}}} \right) = 27.4$$

Draw a line from the 0 dB end of the gain/attenuation axis to the 27.4 dB mark on the Equalization axis.

The nomograph requires only the entry of five items to be used. These are: system tilt; input cable; input flat loss; amplifier gain; and noise limit.

Perhaps the following example of an actual application will best describe the procedure.

Example: amplifier output: +38 dBmV/550 MHz; amplifier gain: 32 dB/550 MHz; input cable: 18 dB/550 MHz; flat loss: 4 dB; system tilt: 6 dB; noise limit: +12 dBmV (minimum level for designed noise performance).

Enter data as shown in Figure 10.

On the Gain/Attenuation axis mark: cable loss: Mark at 18 dB; flat loss (starting from 18 dB): Mark at 22 dB; amp gain: Mark at 32 dB; noise limit (+38 dBmV - +12 dBmV = 26 dB): Mark at 26 dB.

This is the system operating output less the desired input level for the amplifier stations.

On the Tilt axis mark system tilt

21.4 dB mark. Draw a vertical line from the cable loss mark (18 dB) intersecting both the slope factor and tilt axis.

The difference between the flat loss mark (22 dB) and the amp gain mark (32 dB) is the total gain reduction to take place in this

Figure 10

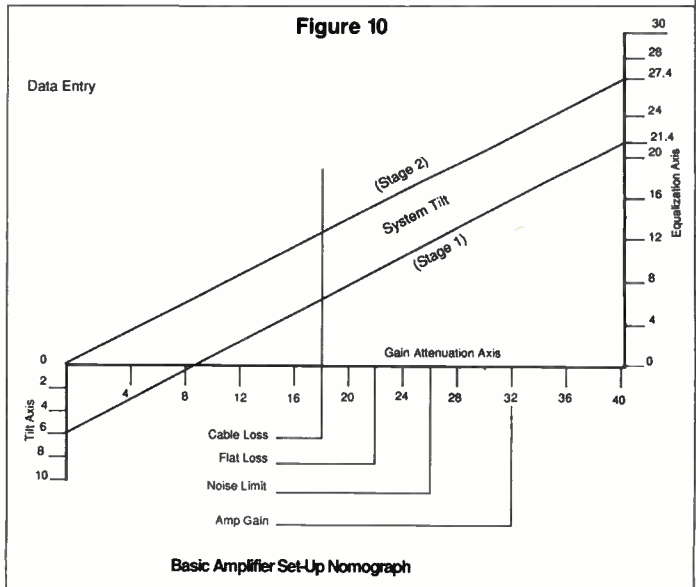

## but our tools are here to stay!

- Made in the U.S.A.
  - Proven in the field for durability
  - Hand-crafted from precision parts
  - Service-oriented manufacturer
- Reader Service Number 15

**cable prep**<sup>®</sup>  
 BEN HUGHES COMMUNICATION PRODUCTS CO  
 207 Middlesex Avenue  
 Chester, CT 06412-0373  
 (203) 526-4337 FAX: (203) 526-2291

## AMPLIFIERS

Figure 11

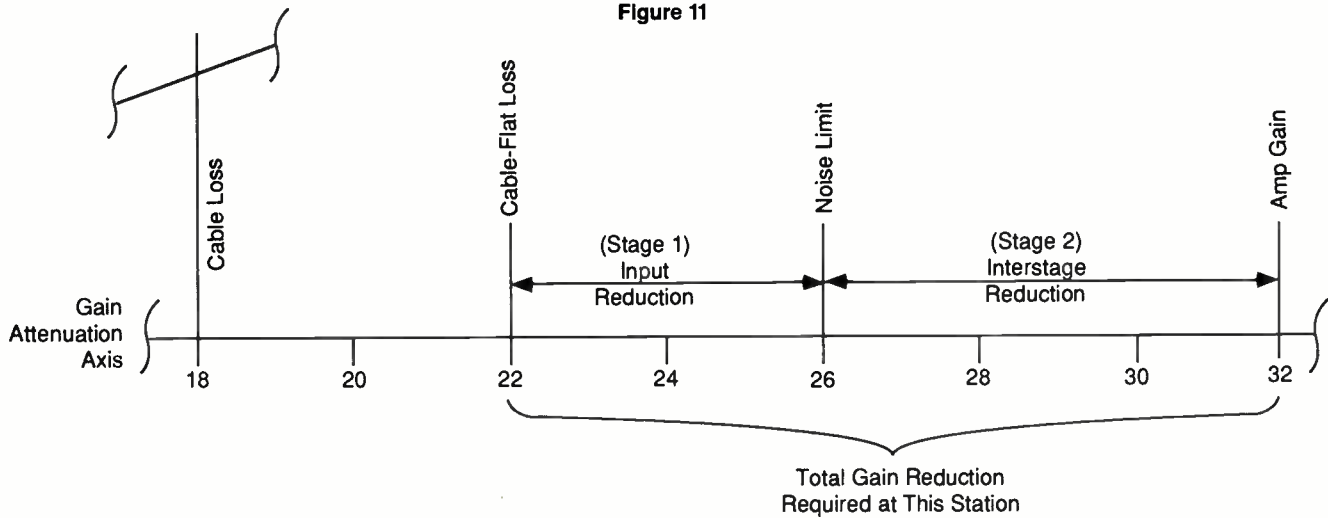

tilt axis is the ideal equalization split. The value from the gain/attenuation axis to this intersection as read on the equalization axis is the required input equalization (in this case, 6 dB). The value from the tilt axis intersect to the slope factor axis intersect is the required interstage slope adjustment. Note that in this ideal case, this slope value is exactly equal to the system tilt. (See Figure 12.)

But what if your amplifier does not have a 6 dB input equalizer available? Then, on the vertical intersection line, mark in the available equalizer values. The distance at which the nearest available value falls *under* the ideal intersect is the amount by which the low channel level will exceed the high channel level in the input stage. Conversely, an equalizer value above the tilt axis intersect indicates low channel

level below the high channel level in the first stage.

In the example of Figure 13, an available 5 dB equalizer will result in the low channel being 1 dB higher than the high channel. An 8 dB equalizer will result in the 50 MHz channel being 2 dB lower in level than the 550 MHz channel in the first amplifier stage.

Let's assume that the amplifier has a limited range of interstage slope

## SECURITY ENCLOSURES FOR SINGLE & MULTIPLE DWELLINGS

### MTE



- No rusting ever
- Super-tough strength
- Easy installation

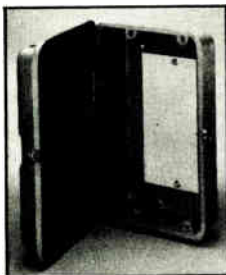

### TUFFBOX

### MSE

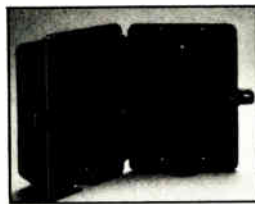

- Excellent chemical resistance
- Non-conductive

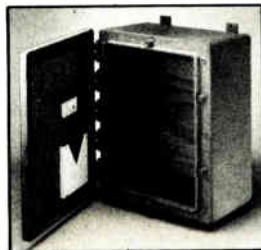

### CABLESAFE

**CABLETEK CENTER PRODUCTS, INC.**  
850 TAYLOR STREET, ELYRIA, OH 44035  
1-800-562-9378 • ELYRIA 216-365-3889



Crystal Stability from Automation Techniques Inc.

## The GLR 500CH and Dual CH Commercial Satellite Receivers



**\$339<sup>00</sup>**

### Model GLR 500CH

Get the features you need in the finest American-made product on the market!



**\$619<sup>00</sup>**

### Model Dual 500CH

Save dollars and space with two receivers on the panel. Features easy-set tuning!

#### Features:

- Descrambler ready
- Signal Type: unclamped, de-emphasized NTSC, composite output
- De-emphasis: CCIR REC. 405 1
- Signal Level: 1 volt p-p ±10%
- Chrominance-Luminance: <1 25 nsec maximum
- Differential Gain: <5% p-p max (10-90 APL)
- Differential Phase: <5° p-p max (10-90 APL)
- Dual Conversion (950 - 1450 MHz)
- Crystal Synthesized
- 70 MHz Loop on back
- Rack Mount
- 3 1/2" High
- Low Threshold Performance
- Quality Video with Crystal Stability
- Relative Power Meter
- Thumbwheel Tuning (GLR 500CH)
- Switchable LNB Power
- MADE IN USA

WE MAKE TECHNOLOGY AFFORDABLE



**Automation Techniques Inc.**

1575 N. 105 E Avenue • Tulsa, OK 74116 • (918) 836-2584 (Oklahoma) • 800-331-5997

Reader Service Number 17



# How Do You Fit 10<sup>1</sup>/<sub>2</sub>" Of Equipment Into 3<sup>1</sup>/<sub>2</sub>" Of Space?

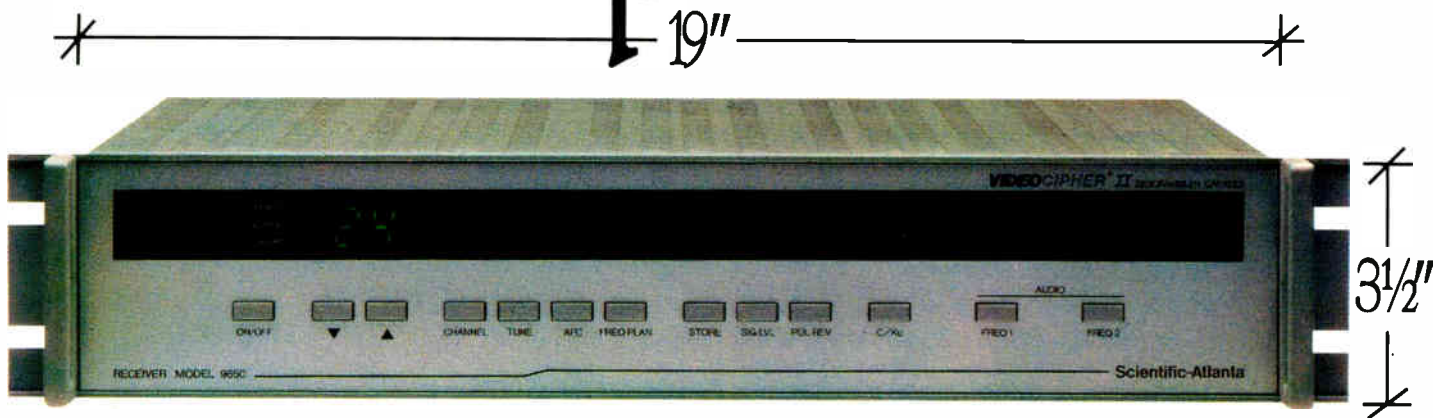

You use the industry's first integrated receiver/descrambler—the 9650 IRD! With headend space at a premium, the 9650 IRD is the best way to beat today's rack space squeeze.

Combine the industry leading 9640 receiver with a VideoCipher® II descrambler in one unit and you have it! Seven inches of extra rack space, assured compatibility, and reduced cabling.

Order the 9650 IRD without the descrambling module now and you can

## The 9650 IRD.

add descrambling capability when you need it.

You'll fit twice the channels in the same rack space with perfect compatibility. Add up the difference. The 9650 IRD — we do it right. Call or write Scientific-Atlanta Dept. AR P.O. Box 105027 Atlanta, GA 30342 1-800-722-2009.

### Scientific Atlanta

Our customers are the winners.

## AMPLIFIERS

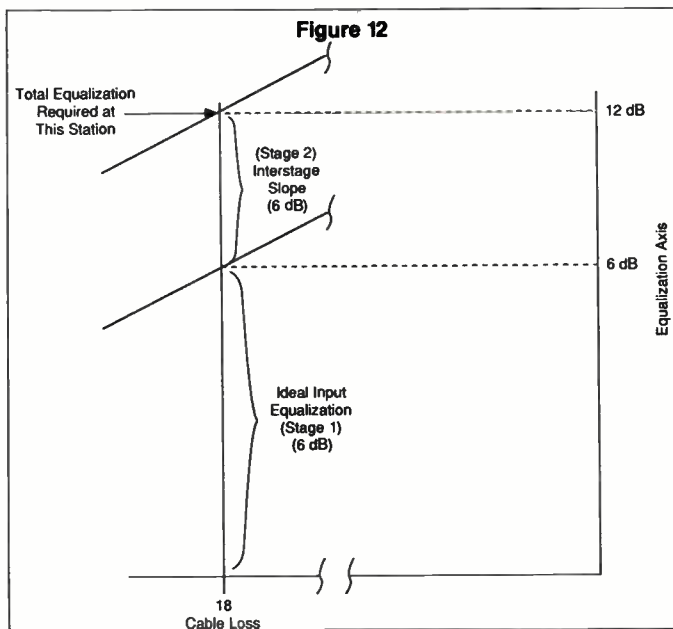

adjustment of 8 dB. Draw a line from the 8 dB mark on the tilt axis to parallel the slope factor line. This slope control limit will intersect our vertical 2 dB below the original intersect. This is the minimum amount of input equalization that can be employed, while allowing the slope control to restore launch tilt. (See Figure 14.)

This particular nomograph will also allow the development of a complete operating envelope for any amplifier overall combination of cable, flat loss, and operational gain. ■  
Next month, in Part 2 of this article,

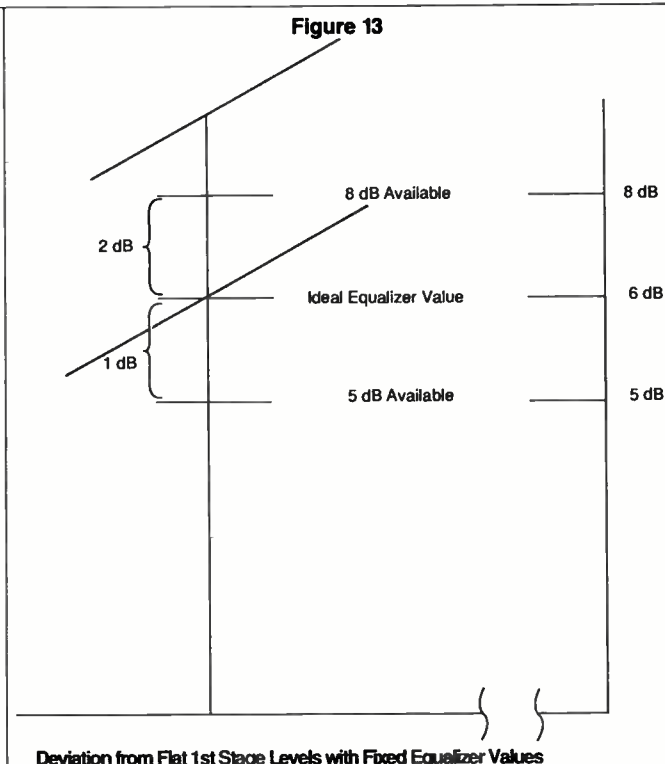

*Poirier applies these amplifier alignment principles to a real-world cable system.*

# LOW NOISE FLEXIBILITY

## AGILE PROCESSOR 361H



**AGILE PROCESSOR 361H**

### FEATURES:

- Selectable Output Channels 2 through YY (54 to 440 MHz) Standard or HRC with Automatic FCC Offsets
- Processor Input Off-Air Channels Selectable 2 through 69 (VHF and UHF)
- Synthesized Oscillators - Crystal Referenced Phase Locked
- Non-Volatile Channel Selection
- +60 dBmV Output using Low-Distortion Hybrid Amplifiers
- External Composite IF Loop-Through
- Sound Carrier Level Adjustable -13 dB to -17 dB
- SAW Filtered IF Designed for Adjacent Channel Operation

## AGILE MODULATOR 360H

### FEATURES:

- Selectable Output Channels 2 through YY (54 to 440 MHz) Standard or HRC with Automatic FCC Offsets
- Synthesized Oscillators - Crystal Referenced Phase Locked
- Non-Volatile Channel Selection
- +60 dBmV Output using Low-Distortion Hybrid Amplifiers
- Low Noise Requires No Bandpass Filters
- SAW Filtered IF Designed for Adjacent Channel Operation
- Phase Lock Loop FM Audio
- 4.5 MHz Subcarrier and Baseband Audio Inputs
- External Separate Audio/Video and Composite IF Loop-Through
- Sound Carrier Level Adjustable -13 dB to -17 dB

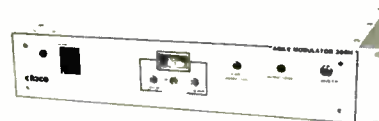

**AGILE MODULATOR 360H**  
4.5 MHz Stereo and Baseband Audio Inputs

Write or Telephone for your FREE Catalog

NCTA Booth 1607



2405 S. Shiloh Rd.

Garland, Texas 75041

Reader Service Number 19

1-800-877-2288

214-271-3651

FAX 214-271-3654



# Do You Know The Difference Between Telephone And CATV Fiber?

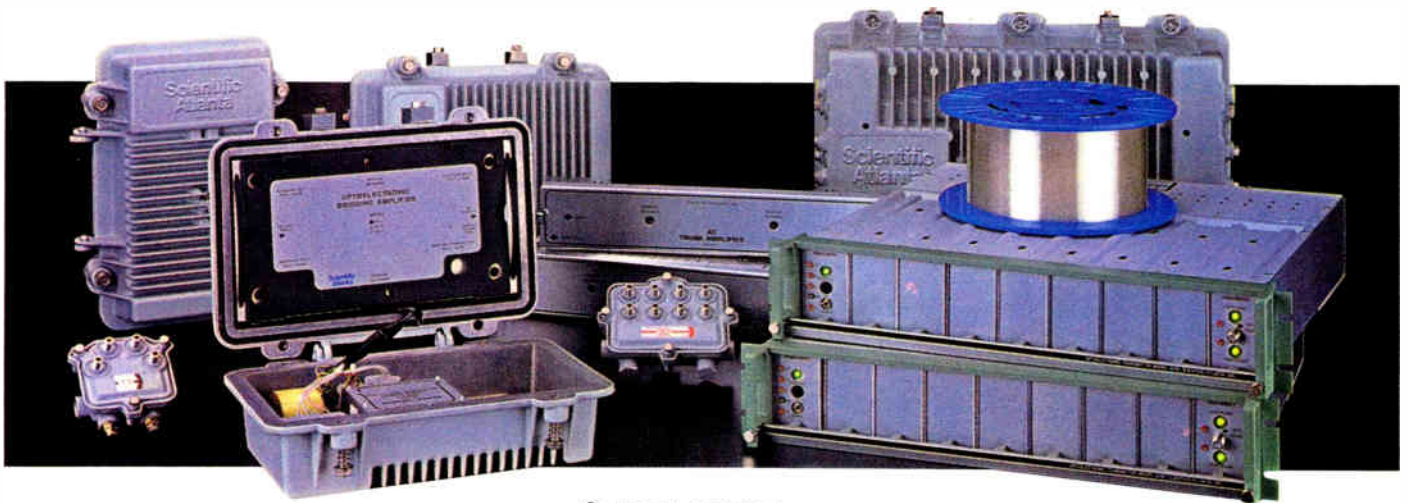

The difference - and it's an important one - lies in our Total Systems Architecture™ approach to CATV. It provides you with the tools to advance your delivery system and protect your investment.

Fiber is fiber. But there the similarity ends. Scientific-Atlanta is the first full line CATV manufacturer to offer it all. Product, system design, service, and support. Introducing the 6450 Optoelectronic Laser Transmitter. Fiber optic cable.

**We  
Do.  
Scientific  
Atlanta**

And, the 6901 Optoelectronic Bridging Amplifier.

Telephone or CATV? Sure the fiber is the same. But everything else about a Scientific-Atlanta fiber optics system is better. These differences are what makes Scientific-Atlanta the company to rely on for CATV fiber optics - we do it right.

Call or write Scientific-Atlanta  
Dept. AR, P.O. Box 105027  
Atlanta, GA 30348  
1-800-722-2009

**Our customers are the winners.**

Reader Service Number 20

# Satellites and cable TV: going in circles

Perhaps not since the years when cable programmers first made commitments to distribute their products via satellite rather than terrestrial microwave, has the cable television industry been faced with satellite delivery decisions of the magnitude they are this year.

1989 will be the year when the industry will apparently re-commit to C-band for the next 15 years, rather than to combined cable satellite and Direct Broadcast Satellite (DBS) delivery using medium-power Ku-band as an initial step toward high-power DBS. It will decide to let DBS go it alone, if it goes at all. Decisions being made this year actually will determine whether America will be a wired nation or a satellite-fed society in the next century.

## A long history

C-band satellites, operating in the 4 GHz to 6 GHz frequency range, have served the cable industry since HBO started delivering its system over satellite. Hundreds of millions of dollars have been invested in the technology and there is at least one C-band receive antenna at every television station and cable television system in North America. Cable operators alone use more than 20,000 C-band dishes.

Surprisingly, C-band has also spawned a substantial business in private TVROs, often called "backyard dishes." Private satellite receive antennas exist all over the country, especially in rural areas. About 2 million Americans receive programming directly from C-band satellites via 6- to 12-foot backyard dishes. And every major city in the U.S. has

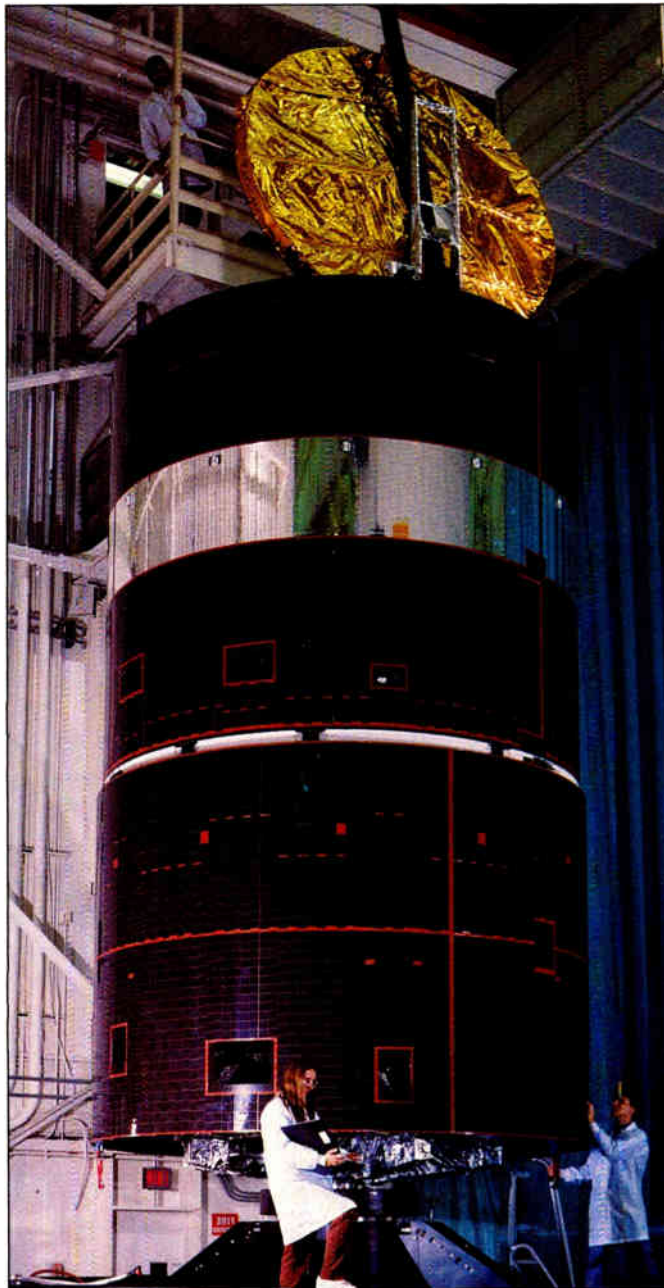

A Hughes Ku-band satellite for Japan nears completion.

one or more fixed uplink video earth station. In addition, there are numerous mobile uplink units used to cover sports, news and other breaking events.

Cable television is delivered by C-band satellites operated by the duopoly of GE Americom (formerly RCA Ameri-

com) and Hughes Communications Inc. The existing C-band cable programming satellites, GE's Satcom series and Hughes' Galaxy series, are nearing the end of their useful life and plans are underway to launch successor replacements.

GE Americom will be launching Satcom C3 in the second quarter of 1992 to replace Satcom IIIIR, and Satcom C4 in the fourth quarter of the same year to replace Satcom IV.

Hughes plans to launch Galaxy V and Galaxy IR, successors to Galaxy I and III, in 1992 and 1993, respectively. It will also launch Galaxy IV in 1991, anticipating increased C-band demand prior to the shutdown of the existing Galaxy birds. For satellite system protection, Hughes plans to launch Galaxy VI, an in-orbit back-up, in 1990. Hughes also owns the three Westar C-band satellites purchased from Western Union last year. Essentially, Galaxy VI will replace one of the Westar birds and Hughes plans replacements for the others as well.

## Commitment to C-Band

News of deals for the replacement C-band satellites has been breaking rapidly since February. This follows intensive discussions begun at the Western Show last December. The competition has been hot and heavy between GE and Hughes to obtain major programmers as "anchor tenants" aboard the transponders. A major anchor tenant on a given satellite can be the catalyst for further deal-making with other programmers because those programmers want to be on the bird that CATV antennas will be pointed to.

The first salvo was a joint venture

By George Sell, Contributing Editor





## Introducing the Sony FSR-1100 high-performance C/Ku satellite receiver.

Better signal reception means more satisfied viewers. And whether it's CATV, SMATV, broadcast or business television, a better picture starts with the FSR-1100 satellite receiver from Sony.

### Performance/Feature Highlights

- Typical threshold extension: 7 dB
- Selectable 24/31 MHz IF bandwidth
- 3 audio outputs: 2 tunable plus 1 fixed subcarrier
- Easy-to-use 10-key tuning plus video fine tuning
- 2-digit strength indicator for precise antenna positioning
- 24 preset C band channels. Programmable memory for presetting of Ku band channels plus audio subcarrier frequencies, polarization and IF bandwidth
- Composite and auxiliary outputs for compatibility with most external decoders
- Input frequency band: 950 MHz-1450 MHz

Simply put, the FSR-1100 is one of the most flexible, reliable, high-performance commercial satellite receivers for the money. And that's a claim backed by Sony's unparalleled experience in professional broadcast and industrial video equipment.

Whether you're operating in Ku or C band, the FSR-1100 delivers superb video and audio reception. Sony's unique adjustable detector

bandwidth can provide improved picture quality under adverse signal conditions. And advanced operating features provide unsurpassed ease of use.

### HEMT LNB's

For heightened Ku band performance, look into Sony's ultra-low-noise block down converters. The first LNB's in the U.S. to utilize Sony's advanced HEMT (High Electron Mobility Transistor) technology, Sony's LNB's achieve exceptionally low noise figures, to 1.6 dB (typical). For sensitivity, stability, reliability and uniformity, they establish new standards of performance, surpassing all currently available GaAs MESFET units.



Sounds impressive? Just imagine how impressed your viewers will be. Write or call for more details on these and other Sony Satellite Communications products.

# SONY®

Satellite Communications, Information Systems Company, Sony Corporation of America, Sony Drive, Park Ridge, New Jersey 07656 (201) 930-7022; Or contact the following authorized Sony Satellite Communications Dealer: Midwest Communications Corp., One Sperti Drive, Edgewood, KY 41017 (800) 543-1584 (606) 331-8990

# SONY BRINGS A BETTER PICTURE DOWN TO EARTH.

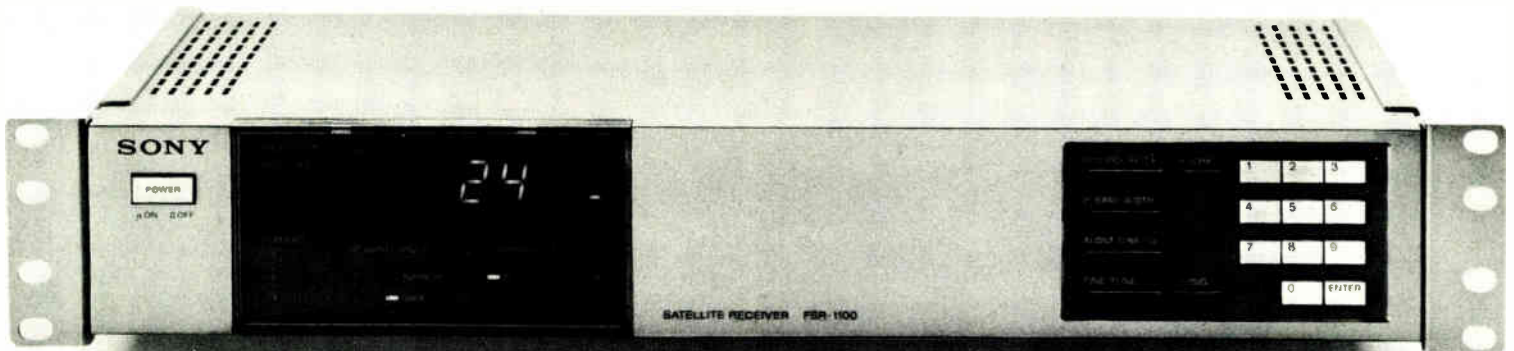

## KU BAND SATELLITE

between Home Box Office and Turner Broadcasting, announced in late February. HBO and Turner agreed in principle to be anchor tenants aboard two of Hughes' replacement satellites. The deal reportedly requires Hughes to launch Galaxy VI as an in-orbit pre-emptible spare. While the terms of the deal were not disclosed, rumor has it that outright ownership of transponders cost first-aboard programmers between \$7 million and \$8 million each. Leased protected transponders may go for around \$150,000 with pre-emptible transponders leased for about \$100,000.

Galaxy V, positioned at 125 degrees west longitude with a footprint that covers all 50 states, will support Turner's Cable News Network, Turner Network Television and Headline News, and HBO's eastern feed. Galaxy IR, at 133 degrees, will carry the HBO eastern combo feed, Cinemax's eastern feed, a second HBO eastern feed, and possibly TNT's eastern feed.

Reportedly, Turner Broadcasting will shift over completely to Hughes. TNT is presently on Satcom IIIR, but HBO will probably continue to also use GE transponders as well. Commenting on the deal, Robert Zitter, vice president for network management at HBO, said,

"We don't need anymore satellite capacity for another 15 years."

CNBC, a new cable financial network owned by GE's NBC television network, committed, not surprisingly, to slots on GE's new Satcom birds in February. Early March saw commitments coming from Viacom to be anchor tenants on GE Americom's C-band satellite replacements. Viacom's Showtime Satellite Networks Group, which includes Showtime, The Movie Channel, MTV, and VH-1, brought with it to GE other independent networks including C-Span and the Weather Channel. Reportedly the deal calls for at least 18 transponders to be reserved. At press time, no deals have been announced for ESPN, another programmer powerful enough to be considered an anchor tenant.

### C-Band vs. Ku-band

Just over a year ago it was not at all clear whether C-band would be the satellite system of choice for future cable program distribution. A debate ensuing for several years over the relative merits of C-band versus Ku-band satellite technology was not resolved until this year, when the end of

the debate was signaled by the above deal-making.

The decision to recommit to C-band was market-driven and based in economics rather than technology, according to the programmers. And the relative technical merits of C-band versus Ku-band technology always depended on who you talked to and in which technology their money was invested.

On the downside, C-band shares frequency spectrum and suffers from terrestrial interference with microwave. C-band requires larger receive antennas, which cost more. However, reception electronics for C-band are relatively inexpensive. In any case, given the length of use of C-band, the ground reception equipment is already in place with an extensive infrastructure built up across the country.

The downside for Ku-band has always been the problem of atmospheric attenuation. Downlinking from Ku-band satellites at 12 GHz during heavy rainfall at the receive site can mean video quality below acceptable standards. Heavy precipitation at a Ku-band 14 GHz uplink site can reduce signal quality over the entire network.

There are economies of scale with

# You Deserve Quality!

Your Quality refurbished converters come from  
**Cable Link, Inc.**



Visit us at the NCTA  
show booth #2827

(614) 221-3131

Buy, Sell, Repair,  
converters, line amps, line extenders, headend, traps, parts



# PI SERIES\* CONNECTORS

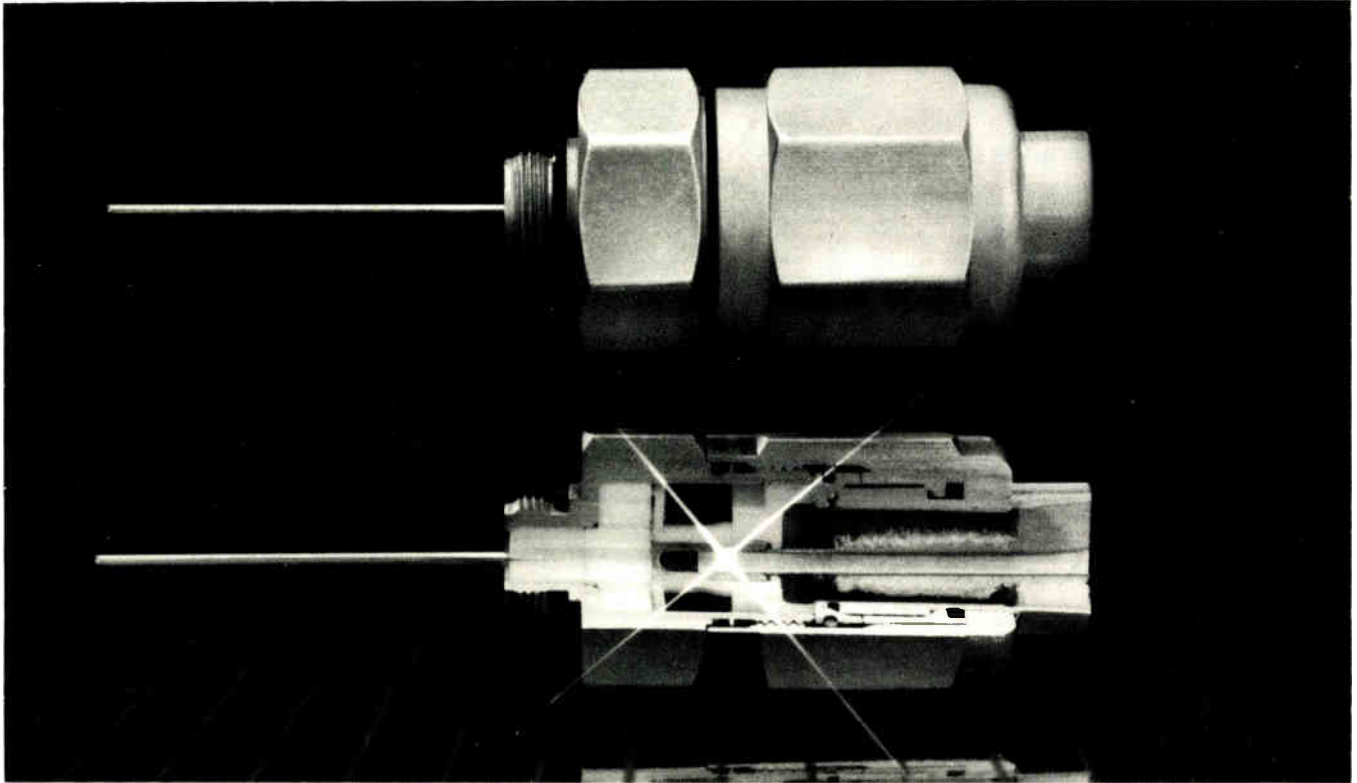

\*PATENT PENDING

## Interface Excellence From Pyramid.

Pyramid Industries offers a unique design in two-piece trunk and feeder connectors; the PI Series. The PI Series yields both a stainless steel sleeve and both cable seizing mechanisms together within the nut assembly.

### PI SERIES FEATURES:

- Two piece construction.
- 75 ohm impedance; 30 db return loss thru 600 mhz.
- Machined 6262-T6 aluminum body; Iridite finish for maximum weather resistance.
- Teflon and Delrin insulators; machined brass contact.
- Captive Stainless Steel Sleeve located and protected within nut sub-assembly; protects sleeve from damage or removal.
- Low-end torque required during wrenching operation; metal to metal positive stop.
- Cable jacket is sealed by means of an EP-O-Ring located in nut sub-assembly; provides weather seal.
- Visual alignment of center conductor into seizing mechanism; insures connection.
- Captive sleeve and cable gripping mechanism "float" within restrictions of nut sub-assembly; eases cable insertion.
- Lightweight design reduces shipping costs; eases handling.
- Part number embossed on assembly; simplifies reordering and connector to cable match-ups.
- Rugged design considerations for maximum durability.
- High level of mechanical and electrical integrity; provides consistent performance, reliability and long life.

Call Pyramid Industries today for your free sample of PI Interface excellence.



**PYRAMIID**  
INDUSTRIES, INC.

DISTRIBUTED BY: TONER CABLE: 1-215-675-2053, SIGNAL VISION: 1-714-586-3196, POWER & TELEPHONE SUPPLY: 1-800-238-7514, WESTERN CATV: 1-800-551-2288, REYCOM CORP: 1-512-494-3328, DF COUNTRYMAN: 1-800-328-6820, WEEKS ENTERPRISES: 1-404-963-7870

## 800-528-4529

3700 NORTH 36TH AVENUE  
P.O. BOX 23169  
PHOENIX, ARIZONA 85063  
(602) 269-6431 FAX (602) 272-7372

## KU BAND SATELLITE

C-band not available with Ku-band. C-band satellite manufacturers can spread their costs over 24 transponders while Ku-band birds offers only 16 transponders. And the space segment of a Ku-band satellite system can cost three times more than C-band because higher power Ku-band birds require additional solar cells and larger power storage capacities, which greatly increases the satellite's weight, which increases the launching costs.

### Ku has limited use

Among existing Ku-band satellites, only one, Satcom K-1 launched in 1986, is used for limited cable program distribution by HBO. GE Americom and HBO, through a Ku-band joint venture known as Crimson Satellite Associates (CSA), attempted to persuade the rest of the cable programming community to join them on Ku-band as an interim step before moving to a combined cable and DBS programming distribution network.

As part of its plan, CSA also had controlling interest in Satcom K-3 and K-4, two identical birds being constructed by GE Americom. With this configuration of existing and planned

Ku-band satellites, CSA attempted to convince other programmers to commit to a more expensive departure, which they argued would result in a system of delivery that would be more appropriate for future market conditions, given the expected development of DBS.

According to a GE Americom executive, "The concept was to take a relatively small step forward, rather than a large leap from C-band to high-power Ku-band that others are talking about now. The concept was this: two medium-power Ku-band satellites would be launched for dual usage—cable headend transition of programming and authorization to home satellite and hotel end users—similar to the situation with C-band today.

"The thought was that this would be a more cost-effective approach for programmers than having two separate feeds, which is, I guess, what the proponents of Ku-band DBS are thinking about, since the same programmers have asked us now to develop successor C-band (birds), which are 12-year satellites.... So they clearly have in mind separate feeds."

"If that double experiment had gone forward and it worked," the same

official says, "we would replace those or move to higher power Ku-band. You had a lot of options open."

### No clear consensus

According to Zitter at HBO, "It's fair to say that our feelings about Ku-band weren't shared by other people who are in the business of distributing cable programming by satellite. No one else stepped up and felt like paying the kind of money that was necessary for the difference between Ku-band transponders and C-band transponders to distribute to headends.

"We felt (Ku-band) gave (a lot of) benefits," Zitter adds. "I doubt that economically it is something that we're going to be prepared to shoulder alone. We never planned to have all of HBO's satellite capacity at Ku-band anyway. We were never going to pull out of C-band. And, I think it fair to say HBO is making it's next generation satellite arrangements on C-band satellites."

Zitter was reluctant to discuss published reports of efforts to sell K-3 to the Societe Europeene des Satellites, owners of the Astra DBS satellite along with Rupert Murdoch's Sky TV service. It is expected the K-3 bird will be used

# 5 Star General

## MULTI-BEAM FEEDS

- Maximize your programming capability, by receiving Galaxy 1, Satcom III R, Telstar 303, Westar 5 and Spacenet with the use of one dish.
- Add to system revenues, through tier expansion.
- Eliminate additional land acquisition and the installation costs of multiple dishes, while increasing your earth station investment.

## MULTI-DISH? OR MULTI-FEED?

The Rainbow Multi-Beam Feed allows you up to 5 prime focus feeds, depending on the size of your antenna.

For a complete list of antennas that can be retrofitted call or write:

## RAINBOW SATELLITE COMMUNICATIONS

Reader Service Number 24

Attn: Brian Wilkes • 1015 Thomas Road  
P.O. Box 395 Leesburg, FL 32748 • (904) 326-8030

**New Product**

## RISER-BOND INSTRUMENTS Model 1210

TIME DOMAIN REFLECTOMETER  
CABLE FAULT LOCATOR

- SUPERTWIST LIQUID CRYSTAL DISPLAY
- AUTOMATIC DISTANCE CALCULATION
- WAVEFORM/DATA PRINTER STANDARD
- RECHARGEABLE NICAD BATTERIES STANDARD
- TESTS ALL TYPES OF METALLIC PAIRED CABLE
- LIGHTWEIGHT, COMPACT AND RUGGED PACKAGING
- EASY TO OPERATE



**\$4,395**  
Complete

For more information or to place an order call or write:  
Reader Service Number 25

RISER-BOND  
INSTRUMENTS

505 16th STREET P.O. BOX 188  
AURORA, NEBRASKA 68818  
402-694-5201



# Why have MSO's ordered over 40 million EZF Connectors?

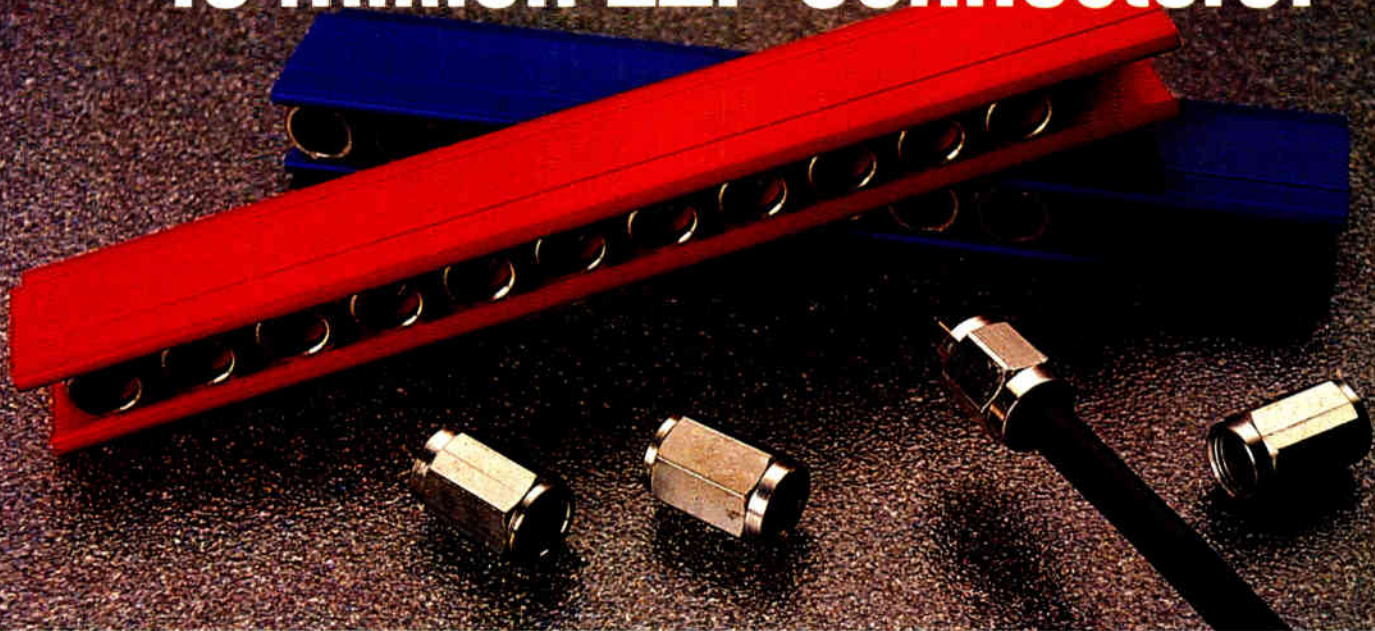

## Lower Maintenance Costs and Improved Customer Satisfaction

In both new builds and rebuilds, users of the EZF connector system are experiencing a dramatic reduction in drop related service calls. RF leakage trouble calls resulting from improper connector installation and corrosion are no longer the single most problem in a CATV system when the EZF connector system is used.

### PROVEN: Fewer problems occur during installation

- One color-coded connector for each cable size minimizes connector selection problems.
- The cable is prepared for installation the same way every time with the EZF cable preparation tool.
- Only a 7/16 inch wrench is needed for installation.
- Cassette packaging facilitates proper installation and reduces connector loss.

- Immediate inspection for proper installation by installers and QC inspectors.



### PROVEN: Fewer problems occur during service life

- A circumferential, environmental seal is automatically made at the connector/cable interface during installation.
- The EZF sealing sleeve supplied with the connector prevents moisture penetration at the connector/port interface.
- Material compatibility and corrosion resistance are ensured by specially selected and tested materials and platings.
- Rugged connector design and consistent installation quality contribute to reduced RF leakage and reliable performance.

**Raychem**

**ANIXTER**

**WEST-ANAHEIM:** (714) 779-0500, (800) 854-0443; **DENVER:** (303) 373-9200, (800) 841-1531; **SEATTLE:** (206) 251-6760, (800) 426-7665; **MIDWEST-CHICAGO:** (312) 364-7000, (800) 544-5368; **CLEVELAND:** (216) 526-0919, (800) 321-8068; **DALLAS:** (214) 446-7337, (800) 231-5006; **IRON MOUNTAIN, MI:** (906) 774-4111, (800) 624-8358; **SKOKIE, IL HDQTRS:** (312) 677-2600; **EAST-ATLANTA:** (404) 995-5110, (800) 241-5790; **LONG ISLAND, NY:** (516) 293-7788, (800) 645-9510; **NEW JERSEY:** (201) 328-0980, (800) 631-9603; **TAMPA:** (813) 626-7115, (800) 282-9164; **CANADA-CALGARY:** (403) 250-9646; **MONTREAL:** (514) 636-3636; **TORONTO:** (416) 625-5110; **VANCOUVER:** (604) 321-5885.

In an emergency, weekends and holidays or after 5 P.M. call toll free 1 (800) 323-8166.  
CORPORATE OFFICES, ANIXTER BROS., INC., 4711 Golf Road, Skokie, IL 60076, (312) 677-2600

See us at the NCTA Show, Booth #1869.

Reader Service Number 26

©1989 ANIXTER BROS., INC.

## KU BAND SATELLITE

as a spare.

But, according to one GE Americom official, who spoke on the condition of not being identified, "K-3 was built and sold. I'm not sure all the T's have been crossed and all the I's dotted, but it will be deployed in Europe by SES Astra, which is no relation to Astro (GE's satellite manufacturing arm), as a DBS satellite for Europe."

GE, however, still holds hope for deploying K-4, along with the existing

K-1, to implement the original Crimson concept. K-4 is nearing completion of construction at GE Astro. And GE has construction planned for a 200 watt Ku-band satellite for future use, perhaps for DBS distribution.

### Crimson vs. CATV

An executive at Viacom's Showtime Satellite Networks Group, who also wished not to be identified, said, "Specu-

latively, we have always, as a company, taken the position we are going to examine all new technology and when we believe the time is right, we're going to act. We had an opportunity to participate in the Crimson deal very early on. At that time we determined it was not in our best long term interest for a variety of reasons.

"The main reason was it wasn't the right kind of satellite. It was not a DBS satellite, it was a fixed satellite. It was going to be burdened by 2-degree spacing in the future and would never realize the size of dish that people talk about when they talk about DBS. Also there was no ground equipment out there. There was no infrastructure. And, there were mixed messages about whether or not it was going to work. It was still confusing. In our sense it was too early."

According to a Hughes Communications video executive, referring to a combined use of Ku-band for cable programming distribution and DBS, "From a technology point of view, it was neither fish nor fowl. It's too big for true DBS and it's too expensive for cable."

An official at Tele-Communications Inc. said, "There doesn't appear to be a clear need for the Ku-band type delivery system. I suspect cable operators were reluctant to enter into any financial arrangement that might lead to underwriting a technology for which there's not a clear need."

However, TCI is showing interest, along with ATC, Comcast, Continental, Newhouse, and Cox, in the use of K-1 for the distribution of superstation feeds to headends. According to Robert Thompson, vice president of government relations at TCI, "There still may be niche opportunities for K-1. Discussions have been going on for some time, and some of them have focused on K-1. K-1 might be used to provide supplementary service for superstation coverage both inside and outside franchise areas. The cable operator would actually provide reception equipment to people to receive superstations. But those discussions have been in the speculative stage for some time and not really risen above that level," Thompson said.

### A casualty of consolidation

Cable operators evidently played a major role in the rejection of CSA's scheme. "That was a very important determinant," says one GE official, "because what was perhaps underesti-

## Make the Switch

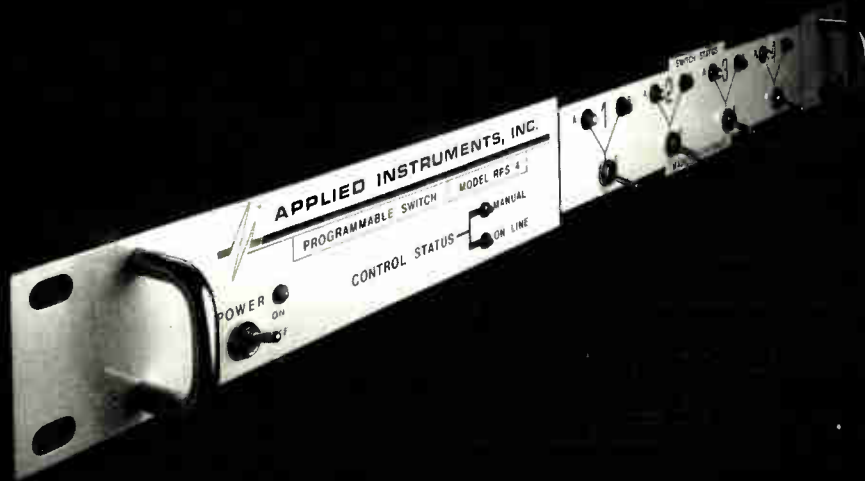

Build your own remote programmable RF/video switch with the Applied Instruments RPS-4. Up to four individually configurable RF or video SPDT switches give you the flexibility to design a switching system that's customized for your particular headend or hubsite application. Convenient rack-mount design and front panel toggle switches make manual operation easy. And, for remote location activation, the RPS-4 offers RS 232C control circuitry on the back panel. All previous switch settings are stored in a non-volatile memory in case of power failure. Make your switch today. Call Doyle Haywood, President, Applied Instruments, or write for our full color brochure.

**317-782-4331**

Applied Instruments, Inc.  
51 South 16th Avenue  
Beech Grove, IN 46107



Reader Service Number 27



# BY THE YEAR 2000, ALL AMPLIFIERS MAY BE THIS GOOD.



**With the  
Magnavox  
Spectrum  
2000 Series  
you don't have  
to wait that long.**

Introducing the shape of the future in amplifiers. Developed through extensive research, the new *Spectrum 2000* is the most technologically advanced amplifier series available. Inside and out.

Designed to shield your broadband electronics from the merciless elements, the *Spectrum 2000* housing\* is unlike any other. Computer designed convection fins provide superior heat dissipation in either vertical or horizontal installations—keeping internal modules cool. Plus, our improved weather and RF seals lock out external elements.

Our extended 5/8 inch ports are standard and are designed to accept a heat-shrink seal where the cable enters the housing. And our optional right angle ports even eliminate the need for 90° and 180° connectors making it a snap to mount in aerial, vault and pedestal installations. For ease of maintenance, the cover is reversible and always opens

\*Patent Pending

in the most convenient way. And it closes tight so no special tools are needed.

The *Spectrum 2000*'s 600 MHz 2-way chassis features improved surge characteristics for protection against transient power surges and color coded fuses for quick identification and easy replacement.

Available in a variety of bandwidths and bandsplits for worldwide usage, the *Spectrum 2000* amplifier is compatible with all Magnavox modules manufactured since 1972.

Bring your broadband system into the next century with the *Spectrum 2000* amplifier series. Call your Magnavox representative for more information.

## MAGNAVOX

CATV SYSTEMS, INC.

100 Fairgrounds Drive, Manlius, NY 13104  
(315) 682-9105 Fax: (315) 682-9006  
1-800-448-5171 (In New York 1-800-522-7464)

# MMDS: Looking for a level playing field

The cable industry has long competed for the subscriber's dollar against such rivals as broadcast networks, VHS tapes, home satellite dishes and franchise overbuilds. Even the telephone industry wants to compete in what is often viewed as a monopolistic industry. But as everyone fusses about a possible telco entry, another competitor is already in the industry—and providing a second choice to subscribers. Wireless cable, or MMDS (Multi-channel multipoint distribution service) has grown from a single system three years ago to 30 systems today serving nearly 300,000 subscribers.

Despite their successes so far, numerous MMDS operators want more. They're bitter about being treated as cable's weaker sister by programmers, angry that their technology is seen as second-rate and are making noise to Congress about the lack of affordable programming.

Although most of MMDS' growth can be attributed to licenses finally being granted, MMDS operators are making inroads by targeting areas currently unserved or underserved by cable. It is

not a new technology, however, there is a new mindset on the part of many MMDS operators and others who see the technology as a viable alternative to cable.

## A simple technology

MMDS technology, which evolved from single-channel MDS, is fairly simple. Using a low-power microwave frequency, the 2 GHz transmitter is capable of transmitting up to 33 channels. The signal is generally 10 watts of ERP (effective radiated power) per channel which provides for a signal delivery of approximately 25 miles (although many MMDS operators say their signal can be carried 30 to 40 miles with little or no degradation). The omni-directional antenna delivers the signals to a rooftop antenna on the subscriber's home and into the attached downconverter. From here on, everything looks pretty much like a cable system: coaxial cable from the antenna into the house, splitters, and set-top converters with remote control. But here the similarity stops.

One significant problem with MMDS is that it is a line-of-sight technology. The receiving antenna must be able to physically "see" the transmitter or no signal is received. And because microwave transmissions do not go through trees or buildings, this can limit the number of potential subscribers. However, MMDS operators do not see this as a tremendous problem.

"Line-of-sight is no longer the problem that it was, although there are line-of-sight problems," says Ken Rosnoy, vice president for TVCN (TV Communications Network Inc.), a MMDS system serving the Denver metro area. "When I say that, indeed if your house is right behind a 10-story building, you're not going to get the signal. However, if you're far enough back and there's enough radiated signal that falls down behind the building through reflection and refraction, you may be able to pick up the signal."

But cable industry engineers are skeptical about the possibility of receiving that signal. "The company I worked for in Hawaii," says Jim Chidix, senior vice president of technology for ATC, "operated an MDS transmitter that had a high ERP gain antenna and a 100 watt transmitter and if there were leaves in the way, you didn't get reception."

Greg Oswald, president of newly launched Capital Wireless, a MMDS system operating in the Albany-Schenectady-Troy, N.Y. area, also sees line-of-sight as a disadvantage in terrains where there are hills, mountains, or in areas where the signal is blocked by a building. "On the other side," says Oswald, "if you can get to an area in downtown, you can certainly do so a lot less expensively by not having to rent conduit, make street cuts and that type of thing."

## Too many or too few?

Another disadvantage associated with the MMDS alternative is the limited number of channels available. This varies from market to market, depending on what was actually licensed to a MMDS operator and what can be picked up from ITFS (Institutional

*As seen from the rooftop of TVCN's office location, the Comband antenna (center) is "looking" at the transmitter (right) on top of El Dorado mountain. The antenna is located 28 miles from the transmission site.*

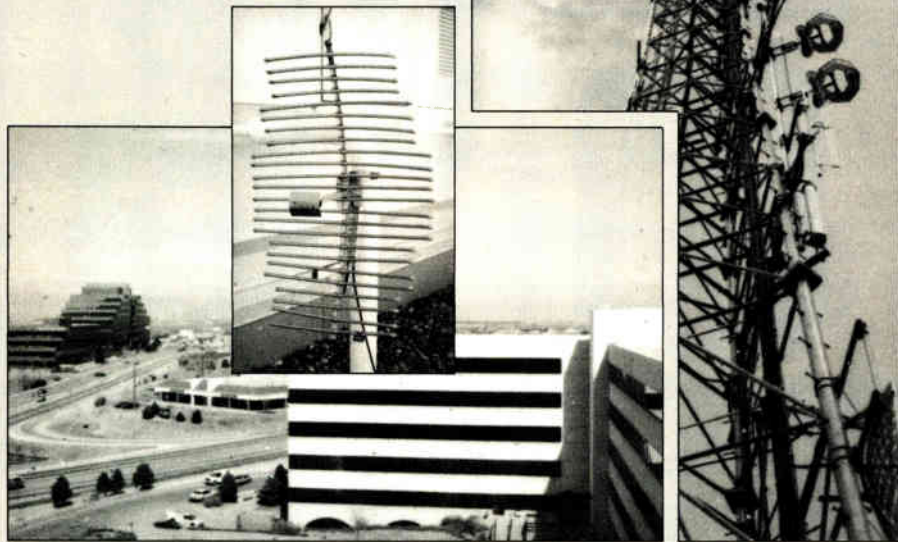



# Now in stereo.

A stereo generator ought to do more than just light the MTS indicator on a subscriber's television set.

It ought to provide clear channel separation, a crisp audio signal, and reliable performance.

It ought to have advanced

features like built-in commercial insertion, a 4.5 MHz output and an AGCL circuit.

And a real DBX® noise suppression system instead of an imitation.

It ought to save precious rack space. And it ought to save money.

Fortunately, one stereo generator does all that. And more. The new CSG-60 from Standard Communications.

The CSG-60 is almost half the cost of conventional units when you purchase them two at a time in the convenient side-by-side rack mount. It has features found only on much more expensive units. And because it's from Standard, you can count on set-it-and-forget-it reliability.

To get the full story on the CSG-60, contact the SATCOM Division for the Standard representative near you.

DBX is a registered trademark of DBX, Inc.



**Standard  
Communications**  
SATCOM Division

P.O. Box 92151  
Los Angeles, CA 90009-2151  
Telephone: (800) 243-1357  
In California: (800) 824-7766  
(213) 532-5300 • Telex: 67-7173

Represented in Canada by:  
DGH Communication Systems Ltd.  
Scarborough, Ontario • 416/499-4746



television fixed services) channels. ITFS channels are frequencies that have been allocated to colleges and universities for educational use. If there are channels that are under utilized, anyone can "buy" the excess capacity. This enables many MMDS operators to offer 20 channels instead of 10.

"It's great to have 50 or 60 channels," says Robert Schmidt, president of the Wireless Cable Association, "but the public is only watching seven or eight of them. You have to pick the right combination but I think it makes sense."

Jim Theroux, president of MetroTen, one of the first MMDS systems in existence, offers between 25 and 30 channels on his Cleveland system. "If you use the compressed signal approach offered by Comband, I guess you could have over 60 channels," says Theroux. "But I think consumers are quite happy with between 20 and 30 channels."

NCTA's Bailey views it differently. "Sure, you don't need all those channels, people only watch 10, but every different person wants a different 10," he says. "That's why we (cable operators) deliver 50, so they (subscribers) have more chance to get their 10 out of those delivered."

The compressed signal approach, offered by Comband Technologies Inc., takes two complete video and audio signals and compresses them into one 6 MHz channel. To restore the signal, a device is provided with the converter built in to allow descrambling of the signal. The Comband technology, which has been described as "the wave of the future for MMDS," by Rosnoy, was initially designed to expand channel capacity. Yet, because Comband is needed to descramble the signal, it provides a fairly secure signal. Reportedly, duplication of the Comband technology can not be done cheaply.

### Don't take my signal

The security aspect is important because theft of the MMDS signal is seen as the largest technical and political issue surrounding the technology. That's not to say that wired cable doesn't also experience signal theft, but the cable industry uses physical drops at the subscriber's home. This enables the installer to disconnect, reconnect or use signal traps to prevent the channel from going into the home. This form of security gives a cable operator more control over signal theft than that offered by broadcast delivery.

Regardless, MMDS operators are confident in the Comband system's ability to provide all the security they need. "If anything, the scrambling system that Comband Technologies uses is among the best in the entire industry, if not, in my opinion, the best," says Oswald.

Technologically, the arguments associated with MMDS can be categorized into disadvantages and advantages. However, the underlying issue behind

## Denverites offered an alternative

Sitting high on El Dorado mountain outside of Denver, Colo. is a 2.5 GHz transmitter that beams its signal over miles and miles of terrain. Although a steep, bumpy, man-made road leads the way up the mountain to the transmitter, once there, a single fact shines in the face of the panoramic view—the potential market that lies in front of the transmitter.

TVCN (TV Communications Network Inc.) is using that signal to provide wireless cable service to the Denver metro and Front Range area. Currently operating four channels, with an additional eight to be added soon, the aggressive company plans to be the largest wireless cable service, offering 38 channels, by the end of 1989.

### Simple plan for success

Ken Rosnoy, vice president of TVCN, believes success will be based on three points: the ability to offer a better picture, a lower monthly cost to the subscriber and better customer service. According to a business study completed by TVCN before launching the venture, 78 percent of the 26,000 households profiled said they would switch service (from their conventional cable) or take the new service. Two of the dominant factors for this decision were cost and customer service.

"The reaction in general," says Rosnoy, "is finally, there is an alternative." As with other wireless cable operators, TVCN sees only one irritant in this startup—programming. Regardless of what the programmers are saying, both Rosnoy and Omar Duwaik, president and CEO of TVCN, see the program suppliers as keeping them from offering what subscribers want. Even though there are 45 services that have said, "yes, we will sell to you,"

MMDS at this time is not so much technical, as it is an interweaving of technology and programming. To date, MMDS operators grouse, very few program suppliers are selling to the wireless market.

### Illegal barriers

"Programming," says Theroux. "Those are the illegal barriers to entry that are going to be the only thing that

the major premium services are still negotiating.

"Nobody in our industry," says Rosnoy, "has a problem with providing a business plan or waiting a certain amount of time to get programming." However, both men see the negotiations with HBO as having come to an end. If necessary, they are prepared to file litigation against HBO in order to get access to the programming. On the other hand, TVCN is presently negotiating favorably with ESPN and Disney and hopes to be able to provide those services sometime this year.

### Bright outlook

Still, the company is optimistic about the future. With a potential market of 1 million subscribers, even at a penetration rate of 22 percent, the universe of subscribers could be 220,000. And based on present cable prices of \$2,000 per subscriber, that puts the possible worth of the future system at \$458 million. This, plus the lower startup, construction and installation costs, make the wireless system very attractive financially.

And added to that, claims Rosnoy, is the niche that is filled by a wireless system. Agreeing with Robert Schmidt, president of the Wireless Cable Association, Rosnoy sees it beneficial for the major MSOs to employ wireless techniques within their own systems. "It's just not economical to wire miles of land to get to two or three subscribers," says Rosnoy. "Or to provide a poor signal because the subscriber is too many amplifiers down the line."

For the time being, neither Rosnoy nor Duwaik are concerned with whether the MSOs will use the wireless technology. Their energy is concentrated on completing and expanding their current system. And if their claim to lower cost, improved quality and better service are proven correct, they could well be what they consider, "an alternative choice."

—Kathy Berlin



IMPORTANT NEWS FOR CATV SYSTEM OPERATORS.

# WESFLEX. HORIZON CABLE.

## Your Number One CIC Connection In The Western States.

Wesflex and Horizon Cable/TVC Supply companies are teamed up to deliver affordable and reliable CIC materials on time—when and where you want them. From trunk to distribution to drop cable protection conduit, we have it all.

Better protection for your buried cable plant translates into better signal quality, better reliability, better subscriber service and better return on your investment.



That's why CATV Systems Operators in the West rely on FLEX-CON™ Conduit to protect their buried cable plants. Friendly to fiber and coax, FLEX-CON™ can be your strongest link from headend to hub to home.

Get the facts about prices and delivery on our FLEX-CON™ Conduit with cable installed, drop-in or empty with pull cords. Call Wesflex, Inc. or Horizon Cable/TVC Supply—Your Number One Cable Connection.



1716 E. Chocolate Avenue  
Hershey, PA 17033  
Telephone: 717/533-4982  
Facsimile: 717/533-6592



934-E Calle Negocio  
San Clemente, CA 92672  
Telephone: 714/361-2011  
Facsimile: 714/361-2106

Reader Service Number 31

# WESFLEX

INCORPORATED

A UNIT OF UTILITECH SERVICES CORPORATION

1880 Garden Tract Road  
Richmond, CA 94801  
Telephone: 415/233-6670  
Facsimile: 415/237-7322

will inhibit the development of the MMDS industry." Others agree. In fact, the feelings of many MMDS operators as to why the programmers won't do business with them can be summed up by Schmidt: "I think it's the big guys (large MSOs) using all their leverage against the programmers, threatening them that if they don't comply, they'll suffer the consequences."

It is essentially statements like this that have sparked the hot political debate that is currently ongoing between MMDS operators, program suppliers, public policy representatives, Congress and the NCTA. According to Chiddix, "The message they (MMDS operators) want to take to Congress is, there's a perfectly good technology out there, probably a viable competitor to cable, but the cable monopolists won't let them in. It just isn't that simple."

In an emotional agreement, Bailey wholeheartedly supports Chiddix's side of the argument "I've never heard of any operator who has said that to a programmer," says Bailey. "We're an industry that's under a great deal of scrutiny. And you don't find a bunch of operators getting together and saying 'the next time one of those MMDS operators comes to you'...they don't get

on a conference call to Michael Fuchs and say 'you better not talk to them.'"

Michael Schooler, deputy general counsel for the NCTA, doesn't see any truth behind the lock-out statements made by MMDS operators. "If that were the case," says Schooler, "there are legal remedies. But I don't think that it's happening."

But according to Schooler, in terms of general principles of antitrust and law, it is generally the case that a distributor of a product or goods can choose his own retailers. The only reason a manufacturer or programmer would choose to limit distribution of his product to a single retailer is because it would somehow be more efficient and increase his total return.

**A marketing decision**

The program suppliers couldn't agree more. ESPN, Home Box Office (HBO) and Showtime say they consider two areas when making a market decision: a wide and efficient means of distribution and effective promotion of their pay service, according to spokesmen.

"Two operators in the same area (whether it's an MMDS operator or an overbuild situation) will attempt to

differentiate themselves by marketing and promotion," says Roger Williams, senior vice president of corporate affairs for ESPN. "And they're going to differentiate themselves in terms of customer service, price and product offering. Now, if they both carry any given programming service, that's not differentiation. So they're less apt to want to promote that service."

And as to the distribution of that signal, perhaps it's related to an initial problem with MMDS—line-of-sight. If a cable operator wires a neighborhood and gets 60 percent penetration, while the MMDS operator is only capable of 60 percent possible viewers, unless the MMDS operation achieves 100 percent penetration, his universe will be smaller than that of cable. When ESPN looks at that market, "you pick the cable operator as your distributor," says Williams. "Because he's going to get you the widest possible distribution."

However, these arguments appear superfluous when faced with the facts. Program suppliers apparently *are* selling to MMDS operators. Perhaps not in every market, nor in every instance, but the signal is being provided on a case-by-case basis. When examining potential affiliates, programmers want

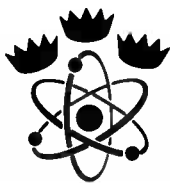

**Nothing Like It!**

The new, highly acclaimed, LA5000 Series of broad application Mini Trunk Line Extenders are available only from Triple Crown Electronics. No one else approaches the benefits of these amplifiers, at any price.

- In-field selectable Bandwidth to 550 MHz.
- Dual integrated circuit design with input and interstage control.
- Power doubling and AGC models available.
- 18-60 Volt switching mode, high efficiency power supply.
- All set-up controls built-in.
- Corrosion resistant housing with stainless hardware proven in years of application.
- Over two decades of innovative experience is built into every Triple Crown Amplifier.

**TRIPLE CROWN ELECTRONICS**



4560 Fieldgate Drive  
Mississauga, Ont. L4W 3W6

(416) 629-1111  
800-387-3205 (U.S. Only)



COMBINATION TOOL handles both cable prep and connector installation

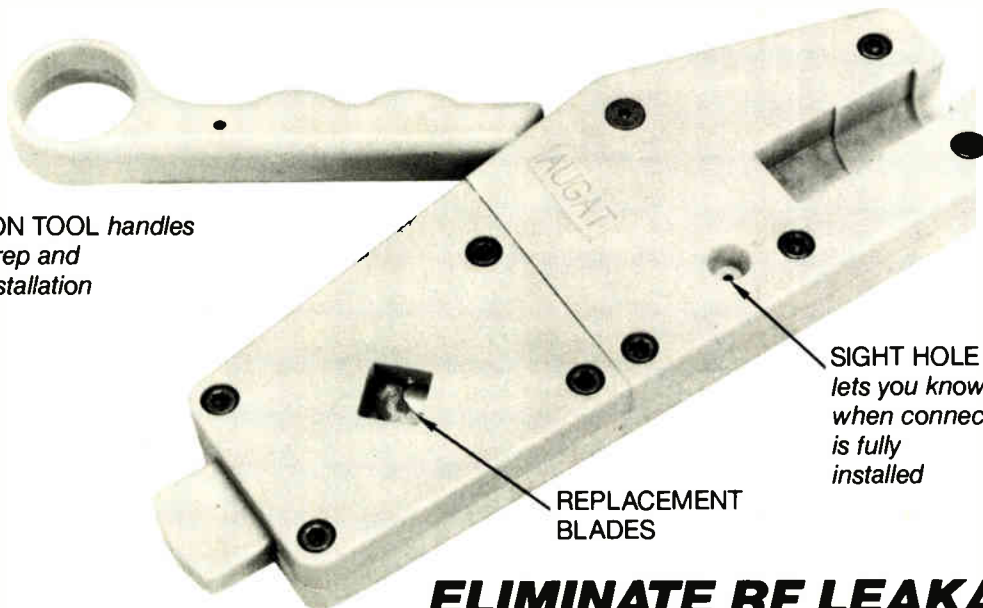

REPLACEMENT BLADES

SIGHT HOLE lets you know when connector is fully installed

Connector/cable color coding printed on tool for easy reference

**ELIMINATE RF LEAKAGE. GET MAXIMUM PROTECTION. INCREASE SERVICE LIFE.**

**ALL WITH JUST A SNAP!**



LRC's Snap-N-Seal™ "F" connector does it all, and it installs in a snap.

Snap-N-Seal's 360 degree compression on the cable jacket ensures a complete radial seal — virtually eliminating RF leakage. Snap-N-Seal™ has a triple seal for maximum protection against harsh environments. This adds up to increased life of drops and reduced maintenance costs.

Snap-N-Seal™ is also a snap to install — no more crimping. LRC even offers a convenient all-in-one tool for installation.

Put a little snap in your "F" connector installations. Call or write Augat Communications Group, LRC Electronics, P.O. Box 111, Horseheads, NY 14845. 607-739-3844.

**Also, ask about these LRC tools and options:**



Open end installation wrench, featuring 1/2" - 7/16"



Weather cap to protect disconnected drops from environmental conditions allowing re-use of the connector.

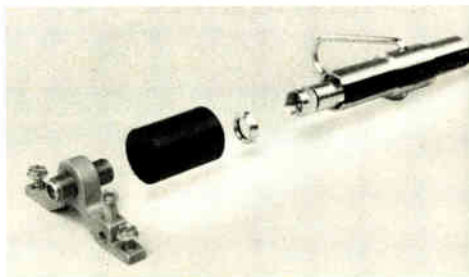

Security shield and security shield tool



WE'RE AUGAT COMMUNICATIONS GROUP. WE TIE IT ALL TOGETHER. WITH EASE.

to see a business plan—one that deals not just with financial capability, but one that also addresses the question of signal security.

"We're talking about very simple business concepts," says Alan Levy, director of corporate public relations for HBO. "The ability to carry a business forward, financially, and the ability to protect your product from being stolen off the shelf, as it were." Although MMDS operators feel their security is equal to that of wired cable, programmers are still looking at the past, when MDS operations were notorious for having their signal stolen and it was not unusual for program suppliers to hear of their service being offered by non-affiliated operators.

This theft of signal and influx of fly-by-night businesses also caused a greater problem for program suppliers—bad debt. Since 1974, HBO has written off millions of dollars in bad debt through dealings with MDS operators. ESPN, after a two-year period of delivering its signal to wireless operators, ended up with more bad debt on its receivables book than actual subscribers. And Showtime blatantly wouldn't deal with MDS or MMDS operators because "we had been burned by a lot of MDS

operators," says Stu Ginsberg, vice president of press and public relations for Showtime, "and we don't want to be associated with companies that go out of business overnight."

Nonetheless, each of the major suppliers is looking at MMDS technology once again. As Ginsberg says, "We're not in it with two feet but we are in it." Showtime currently has two MMDS agreements with operators in New York and Detroit. ESPN, with operators in California, the San Francisco area, South Dakota, Cleveland and other locations, reviews each applicant and licenses the operator if the move is seen as beneficial to ESPN's overall distribution goals. And HBO, with approximately 20 MDS affiliates in major metropolitan areas, is currently working in New York City to scramble the HBO signal for MDS and MMDS applications.

**Competition or nationalization?**

Unfortunately, the MMDS operators are still skeptical. Recently, a bill that would end volume discount pricing and exclusive distribution agreements between programmers and operators was introduced in the 101st Congress by

South Dakota Sen. Larry Pressler. The bill is seen by many in the cable industry as a means to take away from the programmer the right to choose with whom he will deal.

And there are those who think the bill would be better off placed elsewhere. "I think that bill would probably stand a good chance of passage in the politburo, in the Kremlin," says Williams. "In effect, it is somewhat of a nationalization of private business.

However, Schmidt sees it differently. As he stated in the March issue of *Private Cable* magazine, "...all the bill would do is promote competition and give consumers a choice...we don't want a special break or a bailout, all we ask is a fair chance to enter the marketplace and compete for consumers."

So, while the arguments persist about exclusive distribution, line-of-sight, channel capacity and signal security, perhaps the cable industry need look inward once again at customer satisfaction. There may be subscribers who agree with Oswald in that, "I think it's good as far as the consumer is concerned to have another alternative. At least the consumer, hopefully, ends up the beneficiary." ■

—Kathy Berlin



*J. L. Speckman & Associates, Inc.*  
"We Meet Your Specifications"

Here's the specs.



Call Speckman!





**ONE CALL DOES IT ALL!**

- Cable
- Distribution
- Headend
- Drop Materials

- Safety Equipment
- Strand and Hardware
- Hand Tools

Reader Service Number 34

**1-800-826-4710 Toll Free**  
419-394-7890 Corp.  
419-394-5308 FAX

**Emergency Services**  
800-826-4710

*J. L. Speckman & Associates, Inc.*  
dba/SAI Engineering

**NEW! AVCOM PSA-37D**  
**PORTABLE SPECTRUM ANALYZER**  
**WITH DIGITAL FREQUENCY READOUT**

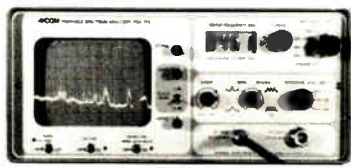

**AVCOM INTRODUCES THE NEW PSA-37D PORTABLE SPECTRUM ANALYZER WITH DIGITAL FREQUENCY READOUT.** AVCOM'S NEW PSA-37D Portable Spectrum Analyzer has a 4 digit front panel frequency readout controlled by a rotary frequency adjustment control. Frequency ranges that the PSA-37D cover are 0 to 500 MHz, 500 to 1000 MHz, 950 to 1450 MHz, 1250 to 1750 MHz and 3.7 to 4.2 GHz. The PSA-37D Portable Spectrum Analyzer is lightweight, portable, battery operated, ideal for field test situations. A built-in DC block with a +18 VDC powers LNAs and BDCs with the flip of a switch. All other performance characteristics and features are the same as the PSA-35A which has become an industry standard for satellite communications work. \$2475



**COM-96T**

The COM-96T Ku/C Band Receiver is compatible with all Ku and C Band LNAs and BDCs operating in the 950 to 1450 MHz range, providing complete 4 and 12 GHz performance in one system. Highly stable oscillators eliminate frequency drift in this fully agile receiver, and allow operation over wide temperature ranges. Special threshold extension circuitry enhances video quality. Threshold peaking and triple IF filters allow the COM-96T to receive international transmissions. This double-conversion, high performance receiver sells for \$839.



500 SOUTHLAKE BOULEVARD, RICHMOND, VA 23236  
Tel. (804) 794-2500 FAX (804) 794-8284 Telex 701-545  
Reader Service Number 35



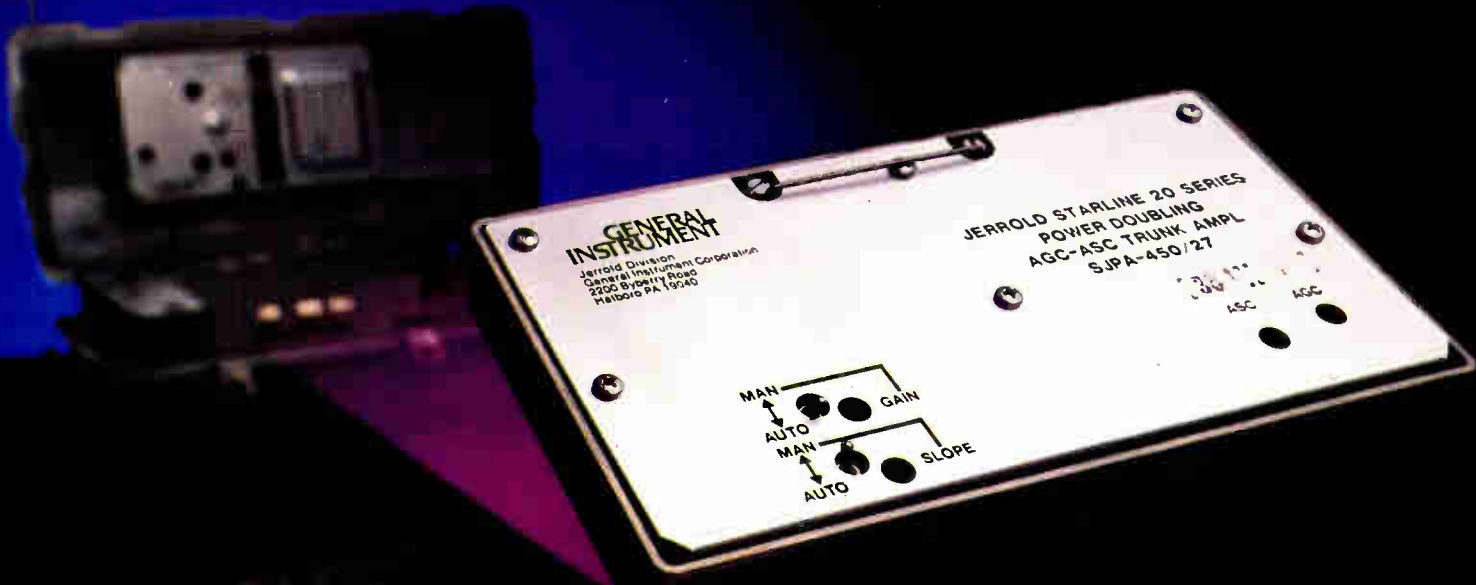

**Double The Performance At Less Than Half The Cost.**

**N**ow you can double the performance of your Jerrold STARLINE 20 amplifiers—and dramatically increase channel-carrying capacity—without major rebuild costs or service disruption.

The S.J.P.A. upgrade module is designed for easy drop-in installation so you can take the labor savings, time savings and hardware savings all the way to the bank. But that's not all . . .

**You Can Bank On the S.J.P.A.'s:**

- ability to expand your present system's channel capacity.
- 5-sided die-cast shell for outstanding heat dissipation.
- exceptionally high picture quality.
- flat or tilted transmission capabilities.

Jerrold's modular approach to upgrades extends all the way down the line: from our high gain, power doubling, JLP line extender modules to our "J" series FFT brass port taps. And this modular design gives you the advantage of backward compatibility, underscoring Jerrold's commitment to long-term customer support.

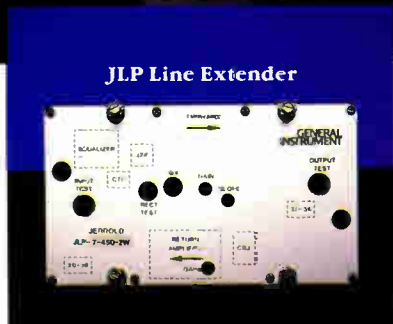

**WHY BUY NEW HOUSINGS WHEN ALL YOU NEED IS MORE ROOM?**

So why throw away money on a new housing when all you really need is more headroom? For more information about these or any Jerrold product, contact your local Jerrold account representative. Or call

or write: Jerrold Division, General Instrument Corporation, 2200 Byberry Road, Hatboro, PA 19040. (215) 674-4800

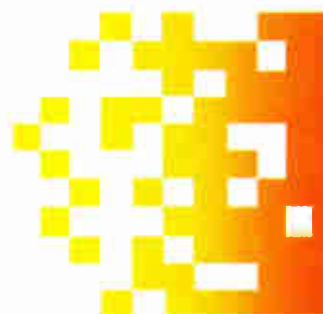

**JERROLD**  
A Division of General Instrument Corporation

# DON'T FORGET WHO TO CALL FIRST FOR FIBER OPTIC ANSWERS.

No single fiber optic system or technology is right for every CATV application.

The question is: which system is the right one for you?

That's a question you should be asking Times Fiber Communications.

Because no company offers more CATV fiber solutions.

From FM to AM to FM/VSB-AM hybrids.

If you're planning to rebuild or expand, now is the perfect time to talk to us

about the advantages of fiber optic transmission. We'll answer your questions on all phases of a fiber optic system. From which technology is best for you to planning the actual installation.

After all, we introduced fiber optics to the cable industry 12 years

ago. To put that experience to work for you, call

(203) 265-8510 or

1-800-TFC-CATV. Or write to

358 Hall Avenue, P.O. Box 384,

Wallingford, CT 06492.



**TFC**

TIMES FIBER COMMUNICATIONS, INC.  
an *LPL* company

Reader Service Number 49



**MODULATOR CALLBOOK**

The following companies have paid a fee to have their listing appear in the Modulator Callbook.

# ANIXTER COMMUNICATIONS

**Anixter Cable TV** . . . . . (312) 677-2600  
**WATS(National)** . . . . . (800) 323-8166

4711 Golf Road

One Concourse Plaza

Skokie, IL 60076

**PERSONNEL:** John Egan, President and CEO; Gordon Halverson, Executive Vice President; Marty Ingram, VP/Product Management & Mktg.; Dean DeBaise, VP/New Business Development  
**REGIONAL OFFICES:** Anaheim: 4905 E. Hunter Ave., Anaheim, CA 92807, (714) 779-0500, FAX (714) 777-1527; Atlanta: 550 Old Peach Tree Rd., Suwanee, GA 30174, (404) 995-5110, FAX (404) 963-5342; Chicago: 888 Thomas Dr., Bensenville, IL 60106, (312) 350-7788, FAX (312) 350-7840; Cleveland: 8060 Snowville Road, Brecksville, OH 44141 (216) 526-0919; Dallas: 1620 Crosby Road, Suite 115, Carrollton, TX 75006, (214) 446-7337, FAX (214) 242-6079; Denver: 8101 E. Prentice, Ste. 210, Englewood, CO 80111, (303) 740-8949; Houston: 4799 Eastpark Drive, Houston, TX 77028-5997 (713) 674-1111; Iron Mountain: 1023 River Ave., Iron Mountain, MI 49801, (906) 774-4111, FAX (906) 774-6287; Long Island: 7 Michael Ave., East Farmingdale, NY 11735, (516) 293-7788, FAX; (516) 293-7503; Orlando: 2901 Titan Row, Suite 124, Orlando, FL 32809 (407) 240-1888; Seattle: 18435 Olympic Ave. South, Seattle, WA 98188, (206) 251-6760, FAX (206) 251-0846; Wharton: 321 Richard Mine Rd., Wharton, NJ 07885, (201) 328-0980, FAX (201) 328-1267.  
**DESCRIPTION:** Anixter Cable TV is a supply specialist to the CATV industry. A complete line of cable television products is offered, including fiber optic cable, connectors, electronics and apparatus, satellite receiving equipment, headend equipment, subscriber devices, distribution electronics, coaxial cable and connectors, aerial and underground construction material, system passives, drop and installation material, tools and safety equipment, and test equipment.



**Cable Link, Inc.** . . . . . (614) 221-3131  
**FAX** . . . . . (614) 222-0581

280 Cozzins St.

Columbus, OH 43215

**PERSONNEL:** E. Jack Davis, President; Bill Holehouse, Vice President of Sales; 'Zack' Zekri, Sr. Account Executive; Stan Smith, Sr. Account Executive; Pete Tippetan, Sr. Account Executive  
**REGIONAL OFFICES:** Lucy Espinoza, 8610 Broadway St., Suite 210, San Antonio, TX 78217 (512) 822-1303/1350  
**DESCRIPTION:** Cable Link Inc. buys, refurbishes and sells CATV equipment. Our products include

addressable, non-addressable converters, linegear, headend, traps, passives, parts, and hardware. We also repair Oak and Jerrold addressable converters. Also CAD Map Design, Character Generator Sales.



**Cable Services Company, Inc.** . . . (717) 323-8548  
**WATS(National)** . . . . . (800) 233-8452

**WATS(State)** . . . . . (800) 332-8545  
**FAX** . . . . . (717) 322-5373

2113 Marydale Avenue

Williamsport, PA 17701-1498

**PERSONNEL:** John B. Roskowski, President; George Ferguson, Vice President; John M. Roskowski, Vice President Construction; Harry A. Wahl, Vice President-Turnkey Sales; Robert Brantlinger, Director/Marketing  
**DESCRIPTION:** Complete fiber optic, coax, or LAN, turnkey construction and supply company. Services include aerial and underground construction, splicing, house drop installation and headend installation. Also supplier of all major manufacturers and in house design, repair and engineering facilities.

# ISS ENGINEERING, INC.

**ISS Engineering Inc.** . . . . . (415) 967-0833  
**WATS(National)** . . . . . (800) 227-6288

**FAX** . . . . . (415) 967-0772

1047 Elwell Court

Palo Alto, CA 94303

**PERSONNEL:** Norman Gillaspie, President; Lydia Gillaspie, Marketing Director; John Ciore, Eastern Regional Office  
**DESCRIPTION:** ISS Engineering Inc. manufactures commercial satellite receivers with IRD, frequency agile modulators, agile processing systems and low noise block converters. ISS also manufactures data communication products and LAN equipment.

# JERROLD

**Jerrold** . . . . . (215) 674-4800  
**General Instrument**

**WATS(National)** . . . . . (800) 523-6678  
**WATS(State)** . . . . . (800) 562-6965

2200 Byberry Road

Hatboro, PA 19040

**PERSONNEL:** George Safiol, President & C.O.O.; Hal Krisbergh, President, Jerrold Division; Anthony Aukstikalnis, VP-GM Subscriber Systems Div;

Lemuel Tarshis, VP-GM Distribution Systems Div  
**REGIONAL OFFICES:** 767 Fifth Ave., 45th Floor, New York, NY 10153, (212) 207-6300; 2611 Westgrove Road, Ste. 108, Carrollton, TX 75006, (214) 248-7931; 7100 E. Bellevue Ave., Ste. 101, Englewood, CO 80111, (303) 740-6118; 556 N. Diamond Bar Boulevard, Ste.106, Diamond Bar, CA 91765, (714) 860-3600.

**DESCRIPTION:** Designer and manufacturer of full line of electronic CATV and SMATV equipment. Distribution systems: conventional, feedforward, power-doubling and Quadrapower(tm) amplifiers, taps and passives and accessory equipment; fiber optics electronics. Subscriber systems: plain, pay and addressable Jerrold IMPULSE 7000 Series, STARCOM and TOCOM 5503-VIP converters, push-button response systems, addressable controllers and scrambling equipment. Headend systems: MATV and CATV satellite receivers, frequency agile headend modulators and encoders, processors, stereo encoders and scrambling equipment; local area network; broadband distribution equipment; advanced status monitoring and point-to-point broadband modems.

# QINTAR INC.

QUALITY SYSTEMS...FOR TODAY'S TECHNOLOGY

**Qintar Inc.** . . . . . (805) 523-1400  
**WATS(National)** . . . . . (800) 252-7889

PO Box 8060

Moorpark, CA 93020-8060

**PERSONNEL:** Randall Tishkoff, President; John Russell, Dir. of Engineering; Michael Spratlin, Director Sales and Marketing; Linda Prueher, Office Manager

**DESCRIPTION:** Manufactures RF switches, (including private labeling), amplifiers, drop material, connectors, processors, modulators, wall plates, filters and telephone accessories. Distributes coaxial cable, videociphers, character generators and satellite receivers.

# Scientific Atlanta

**Scientific-Atlanta Inc.** . . . . . (404) 441-4000  
**WATS(National)** . . . . . (800) 722-2009

One Technology Pkwy.

Atlanta, GA 30348

**PERSONNEL:** William Johnson, CEO; Sidney Topol, Chairman of the Board; John Levergood, Chief Operating Officer; Larry Bradner, Div. President/Broadband Comm.

**REGIONAL OFFICES:** Denver: 61 Inverness Dr. East, Ste.100, Englewood, CO 80112; Fairlawn: 2100 Route 208, Fairlawn, NJ 07410; Indianapolis: 8755 Guion Rd., Ste. G, Indianapolis, IN 46268; St. Louis: Copper Bend South, 926 S. 59th St., Belleville, IL 62223.

**DESCRIPTION:** Complete line of cable TV products including earth stations and receivers, low noise converters, headend electronics, distribution products, taps and passives, coaxial cable, set-top terminals, status monitoring systems, fiber optic distribution systems, and Off-Premises Systems.

# An agile modulator review

In the past few years the use of agile modulators as primary modulators has become commonplace. As the popularity of the agile has increased, so has the debate over the merits of the agile modulator versus the fixed channel modulator. The purpose of this paper is to review the operation and construction of the agile modulator versus the fixed modulator, and then

discuss the areas that the cable operator should be aware of when examining specifications of agile modulators.

## Fixed modulator review

The traditional fixed channel modulator, depicted in Figures 1 and 2, consists of an I.F. modulator, an output converter, an output mixer, and an associated local oscillator, final output filtering and amplification. This ap-

proach was originally chosen because cable systems were 12 channels deep and, given that condition, this was the most cost-effective method of channel generation.

The I.F. modulator accepts video and audio and produces a modulated video carrier and audio subcarrier. At the minimum, the video portion of the I.F. modulator has the following functions:

1) The video is fed through a level adjust control, which determines the modulation depth.

2) The video is buffered, and then sampled and detected, with the detected D.C. output driving an over-modulation L.E.D. or meter.

3) The video goes through a buffer to the clamper circuit, which prevents D.C. level shift with changes in picture level and, subsequently, the peak output maintains a constant level.

4) The output of the clamp feeds a balanced mixer. In the mixer the video is combined with a 45.75 MHz oscillator to give a 45.75 MHz double side-band modulated output.

5) This output is filtered and amplified to give a vestigial sideband response as required to achieve adjacent channel performance.

The audio is input through a level adjust control, which sets the deviation. The audio is then buffered and

By Ken Pyle, ISS Engineering Inc.

Figure 1  
Typical I.F. Modulator

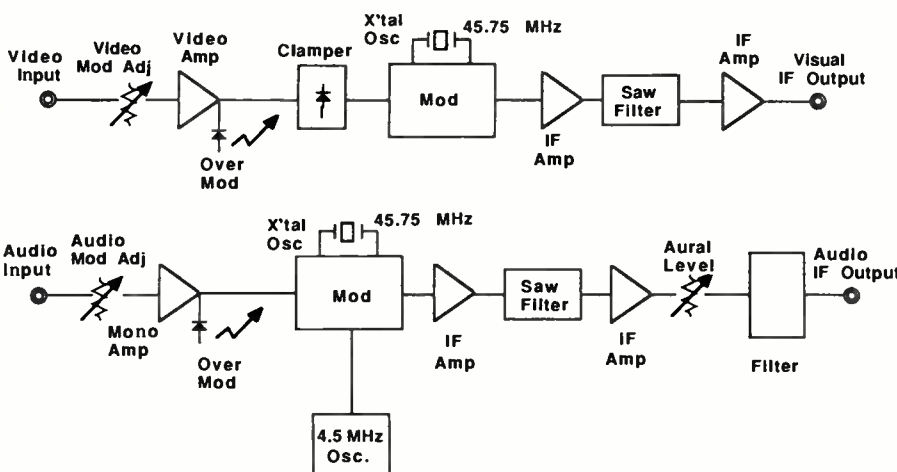
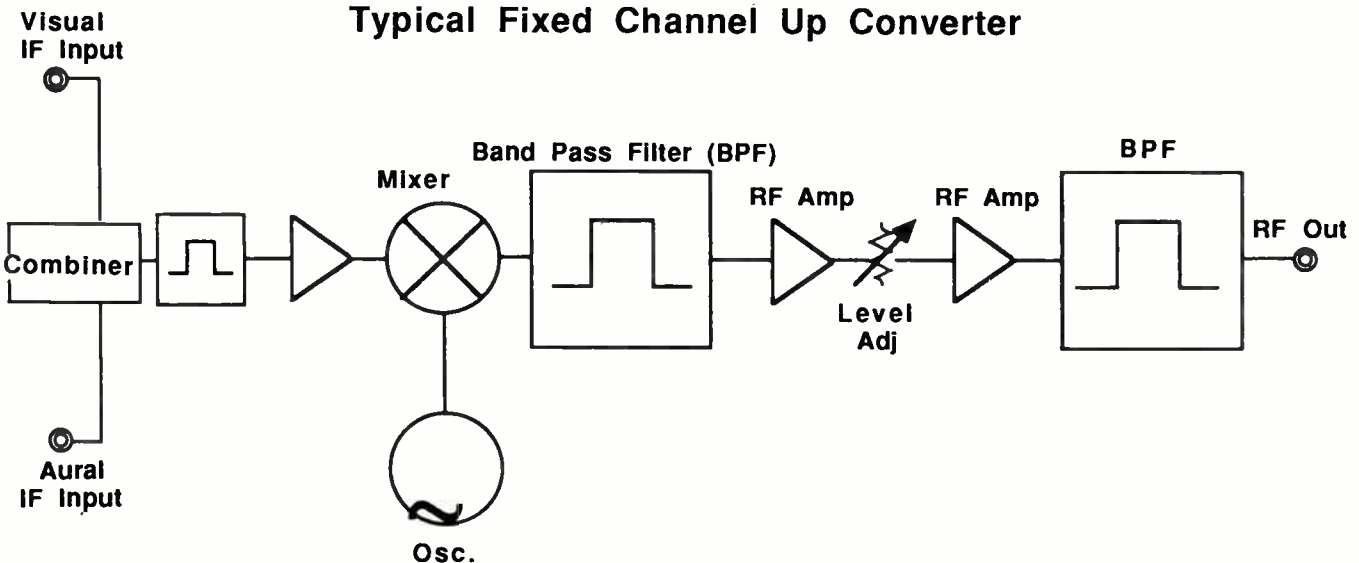

Figure 2

## Typical Fixed Channel Up Converter





**W**ould you like an easy way to increase cable subscribership? To justify rate increases? To maximize profits? Call the Augat BROADBAND ENGINEERING Upgrade Hotline. Find out how easy it is to add channels at a modest cost with upgrade electronics.

**EXPERT ENGINEERING ADVICE OVER THE PHONE.**

Sherwood Hawley, BROADBAND ENGINEERING Applications Manager, can advise you over the phone how your current equipment can be upgraded to handle your subscribers' demands for more channels. He'll point out the "do's and don'ts" of upgrading. He'll

even provide you with a cost estimate for your system's upgrade. All in about 15 minutes. You end up with nothing to lose and a performance advantage to gain.

**GAIN SUPERIOR ENGINEERING PERFORMANCE WITH BROADBAND ENGINEERING UPGRADE ELECTRONICS.**

BROADBAND ENGINEERING originated the concept of upgrade electronics 14 years ago to extend the life of your CATV equipment—without the unnecessary expense and headaches of system rebuilding. You can still be confident of the technical superiority and reliability of our products and advice. And we back up our upgrade electronics products with a one-year warranty.

For a common sense, cost-effective approach to higher profits and longer life for your current system,

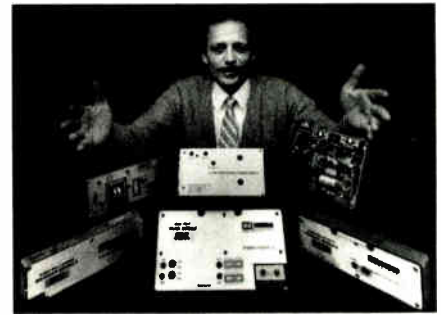

ask for Sherwood Hawley at Augat Communications Group, P.O. Box 1110, Seattle, WA 98111. Call (206) 932-8428 or toll free **1-800-327-6690.**

# KEEPING UP WITH THE DEMANDS OF CABLE SUBSCRIBERS MAKES A LOT OF CENTS.

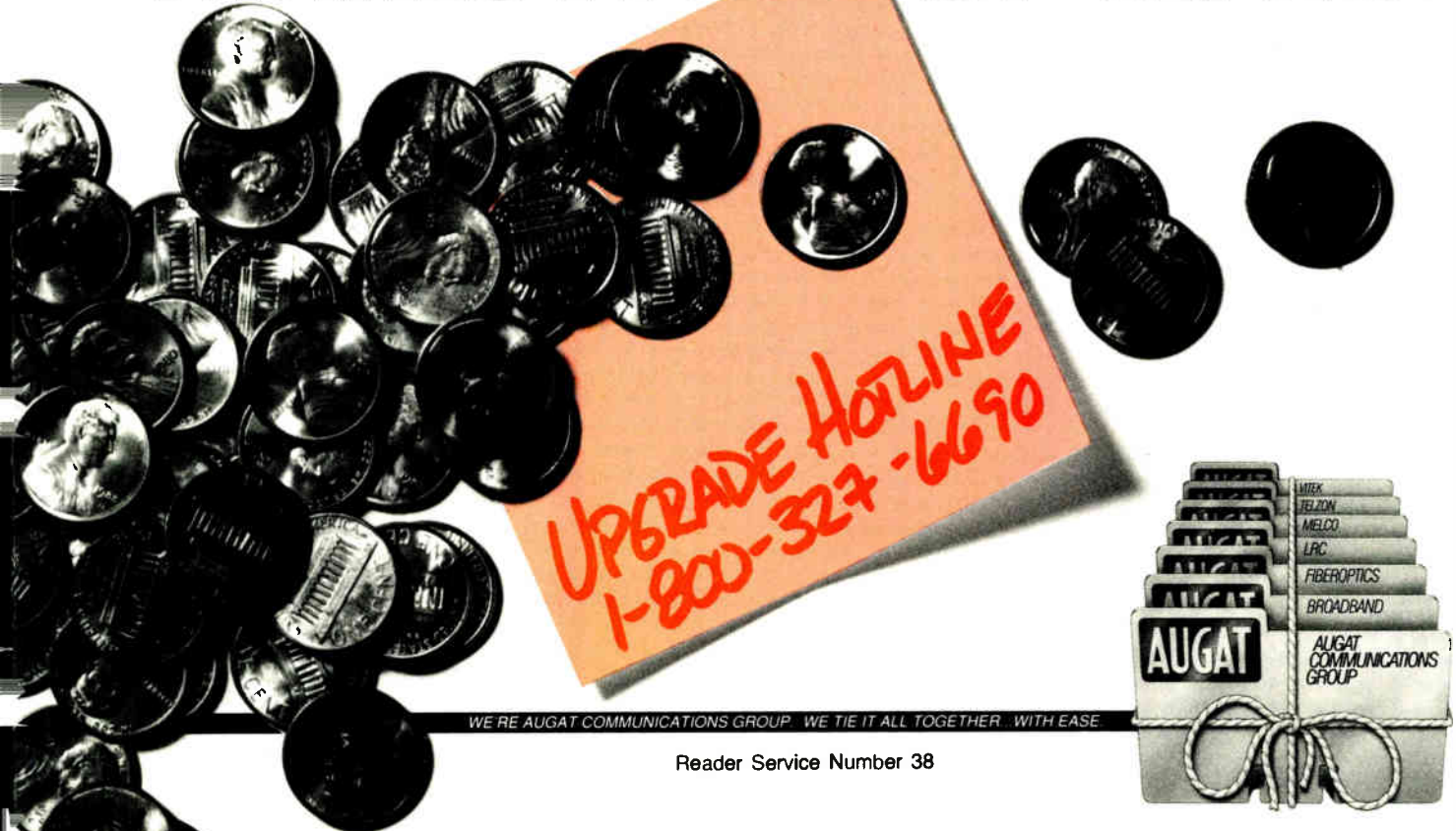

WE'RE AUGAT COMMUNICATIONS GROUP. WE TIE IT ALL TOGETHER. WITH EASE.

Reader Service Number 38



## V<sup>2</sup> REMOTES

- The latest, most innovative compatible remotes from ABC.
- Models are compatible with virtually all popular converters.
- Multiple favorite channel access available on all remotes.



5730 E. OTERC • SUITE 700 • ENGLEWOOD, CO 80112  
IN CO: 303-694-6789 • OUTSIDE CO: 800-777-2259

Reader Service Number 39

## AGILE MODULATORS

frequency modulates a 4.5 MHz oscillator. Most older designs utilized free running voltage controlled oscillators which tended to have frequency drift problems. Therefore, it is very important that this oscillator is phaselocked to maintain 1 kHz intercarrier stability. This 4.5 MHz signal is mixed with the 45.75 MHz oscillator to give a sum and difference output of 41.25 MHz and 50.25 MHz. The 41.25 MHz signal is filtered, removing the undesired signals, and amplified. The 41.25 MHz and the 45.75 MHz carriers are then combined. (Note: Figure 1 depicts a unit with separate video and audio loops.)

To attenuate scrambler generated sidebands, the I.F. should be SAW filtered. The output mixer converts the I.F. to the desired output frequency. For instance, for channel W the output oscillator will be tuned to 341 MHz. Generally, the oscillator components change with the output frequency. Because of this, it is difficult to build fixed channel modulators to stock.

The output of the mixer is amplified and filtered. Generally, this filter must have at least 60 dB of rejection 41 MHz above the upper channel band edge. This means the output bandpass filter must have rather sharp skirts, particularly with higher output channels. The sharper the required filter, the greater the number of components necessary to obtain the desired amplitude response and the more difficult it is to achieve a flat group delay response. A non-flat group delay response can lead to Chrominance to Luminance Gain and Delay inequalities. Also, it becomes difficult to achieve the desired filter without extensive shielding and tuning.

### Agile modulator

The agile modulator's architecture is markedly different from the fixed channel modulator. Figure 3 depicts the typical agile modulator. As shown, the I.F. modulator remains the same whether in a fixed or an agile modulator. To achieve the final output frequency in the agile modulator, a dual-

conversion method is utilized instead of the single-conversion technique of the fixed channel modulator. This method of dual-conversion has become economical in the past decade because of the technological advances and economies of scale that have been achieved for the components that are used in agile modulators.

In this example, the I.F. is upconverted, in the first mixer to a second I.F. of 612 MHz. This is a convenient I.F. because off-the-shelf filters, which are used in other types of R.F. equipment, are readily available. The first oscillator is a voltage controlled oscillator (VCO) and operates at 567 MHz. It

is phaselocked to a crystal reference. This particular example has ovens on the crystal references, improving the output frequency stability. The use of phaselocked VCOs allows for channel offsets that are accessed via the microcontroller, whereas fixed channel modulators must be returned or rechanneled with different components to

change output frequency. Additionally, various frequency formats, such as HRC, IRC, and T-Channels, can be selected by the customer. In fact, it is possible to phaselock the units to a common reference, thus giving a phase related output.

The 612 MHz I.F. filter needs to have rejection of 60 dB to eliminate the image frequency of 521.25 MHz and the 567 MHz oscillator. This is easily and economically accomplished as 612 MHz, helical filters are produced in large volumes at a relatively low cost. Since this filter is typically 8 MHz wide, the group delay is flat over the band of interest, thus adding negligibly to Chrominance to Luminance Delay and Gain inequalities. The output of the filter is amplified to compensate for the loss of the first mixer and the second I.F. filter.

The 612 MHz I.F. is downconverted to the desired output frequency via the second oscillator and mixer. The second oscillator is again a phaselocked VCO. The range of this oscillator, however, varies from 668 MHz to 1058 MHz. The output of the second mixer is then lowpass filtered, fed to a pin diode

To achieve the final output frequency in the agile modulator, a dual-conversion method is utilized instead of the single-conversion technique of the fixed channel modulator.



## AGILE MODULATORS

attenuator (for R.F. level control), and sent to a final output amplifier to give +60 dBmV.

In terms of power consumption, the agile modulator is comparable to a fixed channel modulator. For instance, the power specification on the Scientific-Atlanta 6350 modulator is 40 watts, while the ISS GL2610XT II is rated at 35 watts. In terms of parts count, the main difference is in the output converter. The GL2610XT II output converter has a parts count of approximately 275 versus approximately 160 for a Catel Channel 7 CTM-20 output converter.

From a CATV operator's view, the agile offers consistency of production, which leads to better reliability and reduced costs. The consistency of production results from the fact that all agile modulators produced are identical, whereas each fixed channel modulator is slightly different (assuming different fixed output channels.) Lower costs occur because of reduced assembly/testing time. Also a factor in lowering costs is the reduced manufacturer's inventory, since channelized components do not have to be stocked and fewer subassemblies are required. A fringe benefit to the CATV operator that results from the manufacturing advantages is that the agile modulator is normally an "off-the-shelf" item.

Two concerns that have been raised over the use of agile modulators as a primary replacement for fixed channel modulators have been phase noise and broadband output noise.

### Phase Noise

Any generated electrical signal, whether a crystal oscillator or a free running VCO, is phase (or frequency) modulated in a random fashion.<sup>1</sup> A crystal oscillator has phase noise performance that is more than adequate for CATV applications. A phaselocked VCO, however, must be properly designed to yield acceptable phase noise performance for the CATV system. Pidgeon and Pike's 1988 NCTA technical paper on phase noise in CATV systems provides an excellent review of the subject and gives a baseline for measuring phase noise.<sup>2</sup>

Pidgeon and Pike suggest that the phase noise be measured 20 kHz away from the carrier in a 1 kHz spectrum analyzer bandwidth. The level at which the phase noise becomes perceptible is -52 dBc to -56.5 dBc. The phase noise will tend to dominate at lower frequencies and will appear as long streaky

VERSALIFT

# GAIN MORE SIDE REACH AND BETTER LINE ACCESS WITH THE NEW TEL-29EA



*Boom-tip-mounted bucket puts your operator two feet closer to that hard-to-reach splice. And it provides line access from 3 sides of the bucket, eliminating expensive rotators.*

Positive hydraulic bucket leveling gives a solid, stable work platform, leading to increased productivity and greater worker satisfaction.

A "cat-track" carrier system for control, air and hydraulic lines means less maintenance, more "up-time."

The VERSALIFT TEL-29EA can be mounted on any 10,500 dual rear wheel chassis with 60" C.A. and can be tailored to meet any aerial work requirement.

See your VERSALIFT Distributor for complete specifications, pricing and a demonstration!

**It's TIME to  
check out VERSALIFT!**

  
**TIME**  
MANUFACTURING COMPANY

P.O. Box 20368 Waco, Texas 76702-0368  
(817) 776-0900 TELEX (910) 894-5218 FAX (817) 776-7531

TEL - 29EA  
Reader Service Number 40

# VERSALIFT

## AGILE MODULATORS

lines. The phase noise of the video carrier from the GL2610XT II is depicted in Picture 1. As can be seen, the phase noise is -65 dBc, offset 20 kHz, in a 1 kHz spectrum analyzer bandwidth, proving that an agile modulator can meet CATV required phase noise performance.

### Broadband noise

Broadband noise from the output of

the agile modulator has been a justified concern of system engineers, when comparing fixed and agile modulators. This noise has the effect of adding on a power basis, in a similar manner that noise adds in amplifier. The noise level varies with manufacturers. Note: if using a spectrum analyzer to measure the noise level, a correction factor must be added.<sup>3</sup> Depending on the number of agile modulators in the system, the broadband noise can degrade the C/N

at the output of the headend to less than the NCTA recommended 60 dB.

The effects of the broadband noise can be overcome through the judicious use of inexpensive filtering. These filters, unlike the filters in the fixed channel modulator, do not need the sharp rejection and narrow bandwidth. In fact, the 3 dB points of the filter should be relatively wide, ensuring flat group delay. These filters attach directly to the rear panel connector, eliminating cable lengths and possible return loss problems.

### An analysis

The following is an analysis of 64 combined agile modulators with filtered outputs. Note, to simplify the mathematics, the filter is assumed to

The effects of the broadband noise can be overcome through the judicious use of inexpensive filtering.

have the characteristics described in the assumptions below.

**Assumptions.** 1) The system is a 64-channel system, with 64 identical modulators.

2) In-band noise, measured in 4 MHz bandwidth, of -5 dBmV (in-band C/N of 65 dB).

3) Broadband noise output of -7 dBmV in 4 MHz bandwidth with output carrier level of +60 dBmV (out-of-band C/N of 67 dB). All carriers set to +30 dBmV.

4) The filter's 3 dB bandwidth (half-power bandwidth) is 12 MHz wide. In this case, the 3 dB bandwidth of the filter falls in the middle of the upper and lower adjacent channels. Thus, the average adjacent channel rejection would be approximately 3 dB. The average absolute noise level would be -10 dBmV (-7 dBmV -3 dB).

5) The filter is, on average, 24 MHz wide at the 6 dB points. This gives an average broadband noise contribution of -13 dBmV (-7 dBmV minus 6 dB) from the two channels next to the adjacent channels.

6) The filter, on average, is 36 MHz wide at the 20 dB points, which is also the ultimate rejection of the filter.

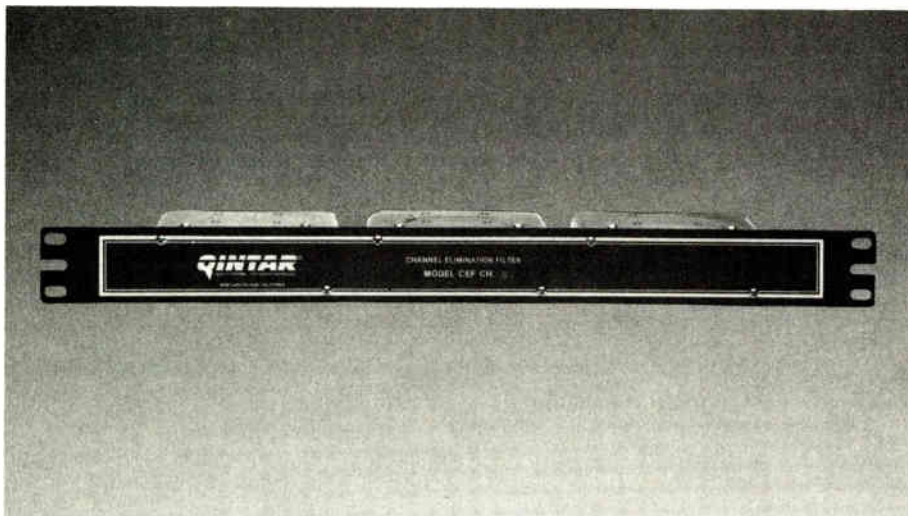

## OUT WITH THE OLD CHANNEL, IN WITH THE NEW.

It's Qintar's new Channel Elimination Filter, Model CEF. It offers clean, precise, high isolation elimination of any 6 MHz wide television channel. And it's available at half the price of competitive channel elimination filters because Qintar's economically mass-produced, immediately deliverable CEF does a job in every way comparable to the competition's costly-to-make custom models which

take from six to eight weeks to deliver.

The Qintar CEF is available in low, mid and highband, offering a signal attenuation of -50dB minimum to -55dB typical. It will

precisely eliminate any channel in a fully loaded system and allow the reinsertion of any program you desire. So why pay more when Qintar technology delivers comparable quality at half the cost?

To place an order, ask a question or receive a free catalog call: (800) 252-7889 or (805) 523-1400. FAX (805) 523-1491. Or write to Qintar, Inc., P.O. Box 8060, Moorpark, CA 93020-8060.

Reader Service Number 41

**QINTAR**  
QUALITY SYSTEMS FOR TODAY'S TECHNOLOGY.



# INVEST IN SOLID PERFORMANCE



**Y**ou've invested in standby power. The payoff is system reliability. But your investment could be short-circuited if your batteries aren't up to the challenge.

Car batteries and boat batteries are fine—for cars and boats. But often they require expensive, time consuming maintenance. More importantly, they can present serious safety and liability problems by giving off dangerous gases. Also, their short life doesn't offer an attractive return on your investment. An inexpensive two year battery costs much more in the long run than a slightly more expensive battery that lasts five years or more. You don't need an electronic spreadsheet to figure out you'll get a better ROI.

If your standby system is filled with low-quality batteries about to fade like the October '87 Dow, here's a hot tip for a better business plan: invest in Johnson Controls Dynasty Gel Cell batteries. You'll maximize your investment with their solid, reliable and maintenance-free performance. At Alpha Technologies, our job is to back you up. And we can do that with Johnson Controls Dynasty Gel Cells.

JOHNSON  
CONTROLS®

alpha  
ALPHA TECHNOLOGIES

3767 Alpha Way Bellingham, WA 98225 206-647-2360 FAX: 206-671-4936  
5700 Sidley Street Burnaby, B.C. V5J 5E5 604-430-1476 FAX: 604-430-8908

Reader Service Number 42

# AGILE MODULATORS

Figure 3

## Typical Agile Up Converter

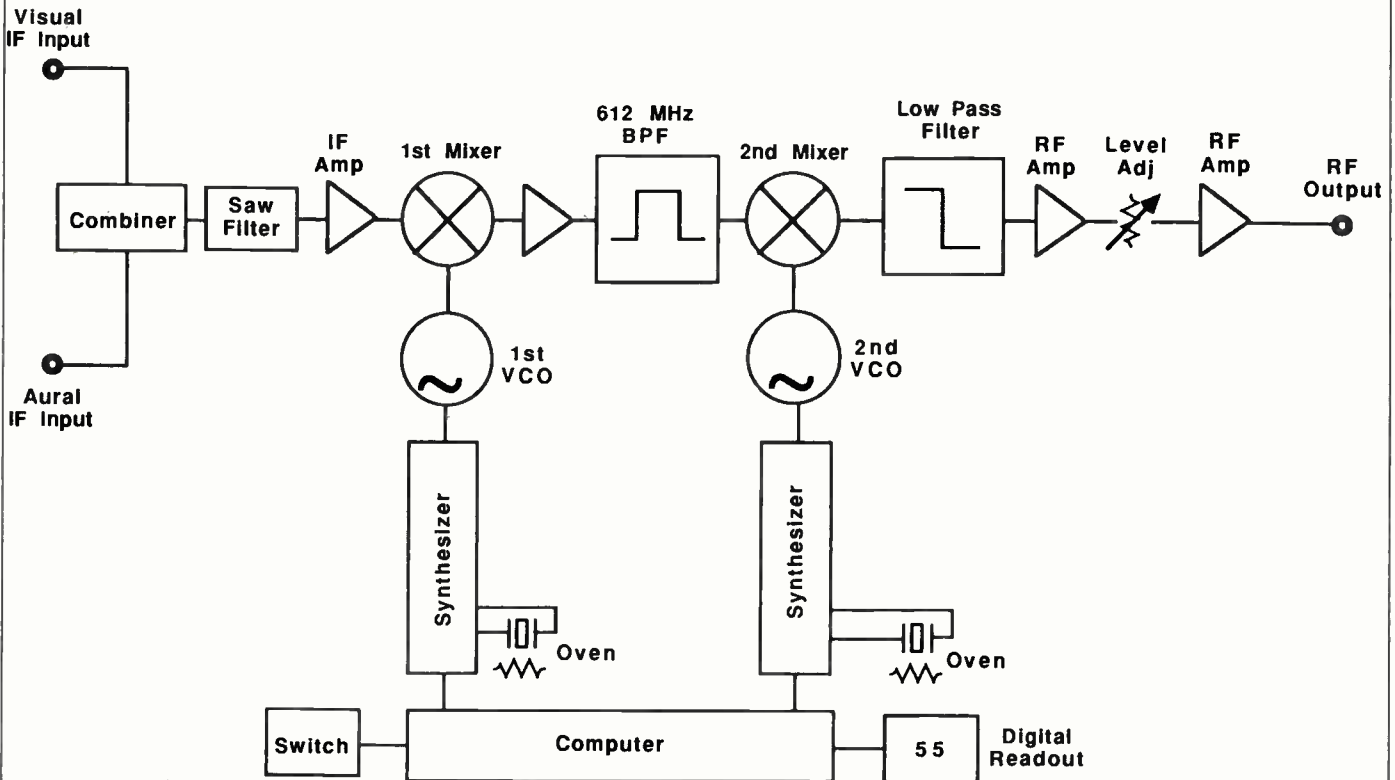

Note: The ultimate rejection in real life is greater than 40 dB, however, to simplify the calculation, a worse case of 20 dB was used. This gives a broadband level of -27 dBmV (-7 dBmV minus 20 dB) per modulator.

**Calculations.** The general formula for combining adding various broadband noise sources to obtain a single channel carrier-to-noise is as follows:

$$C/N_t = -10 \log N_1 \cdot 10^{-(C1/10)} + N_2 \cdot 10^{-(C2/10)} + \dots + N_r \cdot 10^{-(Cr/10)}$$

Where:

$C/N_t$  = In-band carrier-to-noise after combining noise contributions of modulators.

$N_r$  = Number of channels with contributing a carrier-to-noise ratio equal to  $C_k$

$C_k$  = Carrier-to-noise ratio due to a single modulator.

$$C/N_t = -10 \log 10^{-(65/10)} + 2 \cdot 10^{-(70/10)} + 2 \cdot 10^{-(73/10)} + 59 \cdot 10^{-(87/10)}$$

$$C/N_t = 61.34 \text{ dB}$$

This adequately achieves the NCTA suggested C/N of 60

dB at the headend.

### Conclusions

Because of economies of scale and consistency of production, the agile modulator is cost competitive with the fixed channel modulator. Additionally,

with respect to phase noise performance, the agile modulator, if properly designed, is sufficient for CATV use. Broadband noise problems can be eliminated through the use of inexpensive filters. Based on these facts, the use of the agile modulators as the primary modulator should be considered in the design of new headends. ■

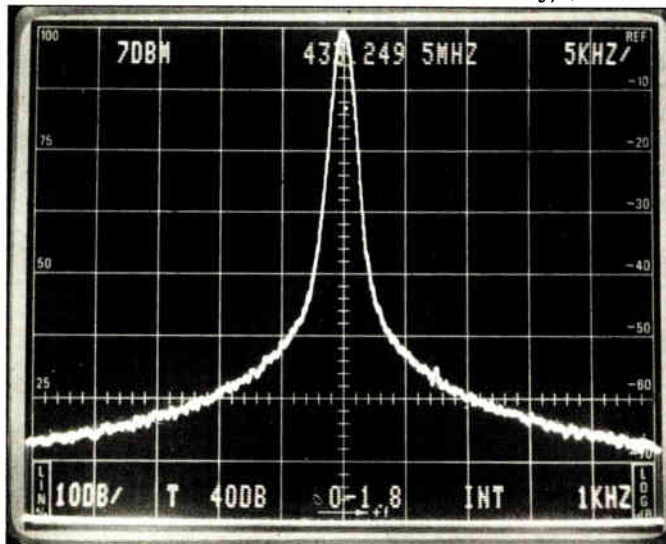

Phase noise of a typical agile modulator.

### References

<sup>1</sup>Manassewitsch, Vadim, *Frequency Synthesizers: Theory and Design*, 3rd Ed., Wiley-Interscience Publications, New York, p. 104.

<sup>2</sup>Pidgeon, Rezin and Pike, Dan, "Oscillator Phase Noise and Its Effects in a CATV System," 1988 NCTA Technical Papers, published by The National Cable Television Association, Washington, D.C., 1988, pp. 187-195.

<sup>3</sup>Hewlett-Packard, *Cable Television System Measurements Handbook* publishing by Hewlett-Packard Co., Santa Rosa, Calif., 1977, pp. 44-47.



# Under \$95,000!

**MICRO-BEAM® 5-Watt Transmitter,  
3 Receivers, 60 Channel System...Installed.**

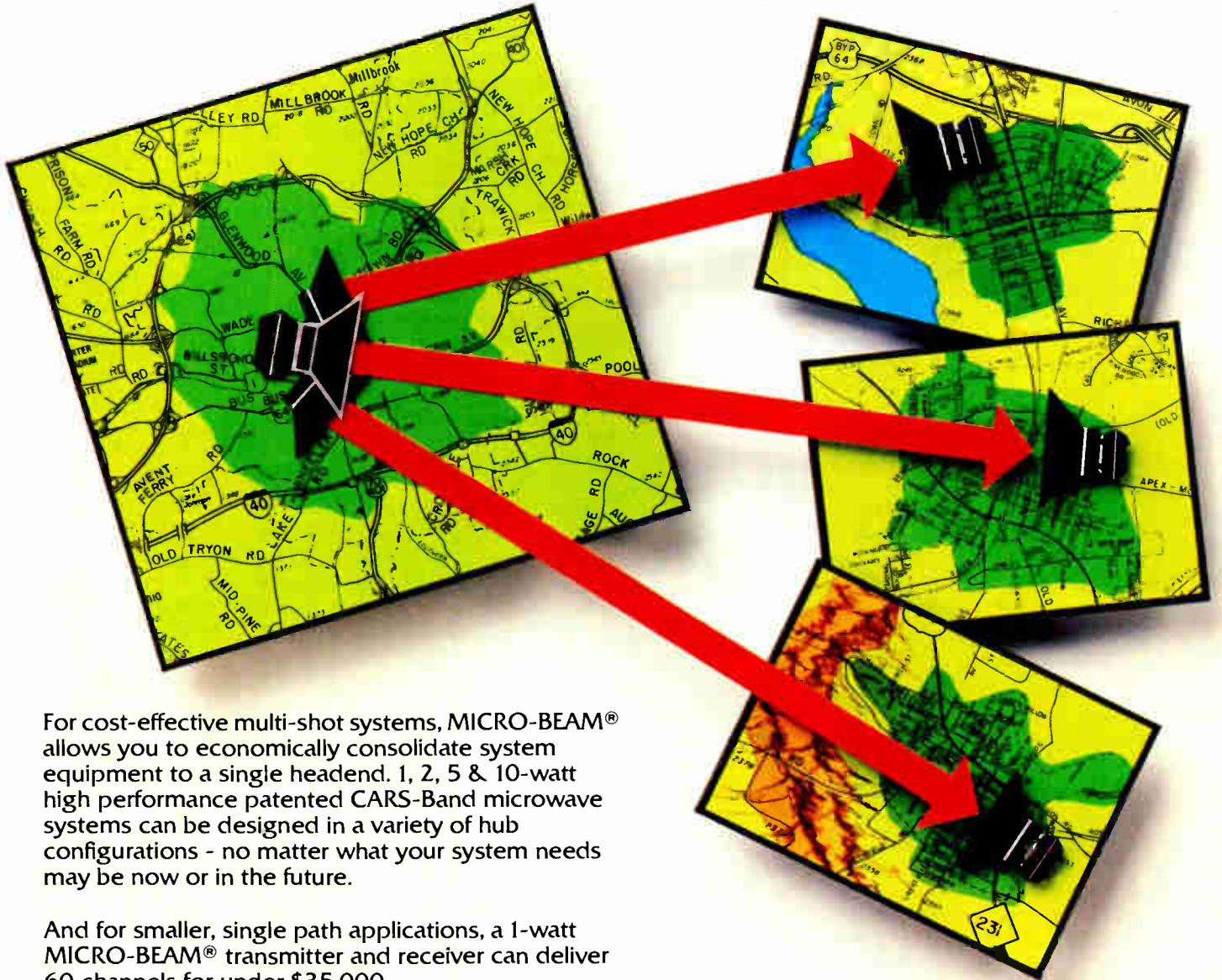

For cost-effective multi-shot systems, MICRO-BEAM® allows you to economically consolidate system equipment to a single headend. 1, 2, 5 & 10-watt high performance patented CARS-Band microwave systems can be designed in a variety of hub configurations - no matter what your system needs may be now or in the future.

And for smaller, single path applications, a 1-watt MICRO-BEAM® transmitter and receiver can deliver 60 channels for under \$35,000.

## **All MICRO-BEAM® Systems are:**

- **Fully weatherized for tower mounting**
- **Rigorously tested and computer monitored for 1000 hours**
- **In-stock, giving you the fastest lead time in the industry**
- **Backed by a 24-hour, 7-days a week technical and warranty service.\***

\*Continental U.S. Only.

The MICRO-BEAM® standard equipment and service package comes complete with everything

you need to make your system operational (excluding antennas and towers), so you won't have to worry about "high cost" options.

For more information on how you can make your cable system more profitable, contact:  
**Jim Crossover, MICRO-BEAM® Sales Manager.**  
See us at the NCTA Show, Booth #2424.

**Channel Master®** Division of Avnet, Inc.

P.O. Box 1416, Industrial Park Drive, Smithfield, N.C., 27577 (919) 934-9711  
Prices subject to change without notice.

Reader Service Number 43

# Laser designers aim at CATV marketplace

**D**istributed feedback, Fabry-Perot, YAG, quantum well, buried crescent, double planar, shift distributed—the list of laser design concepts is expanding at a mind-boggling rate in the area of photonics devoted to telecommunications, leaving CATV decision-makers to wonder if the rampaging R&D engine that's driving fiber optics will ever slow down long enough to permit them to hop aboard.

Ever since laser mania struck the cable television industry a couple of years back, globe-hopping contingents of MSO and manufacturing engineers have been on a worldwide search for transmitters with application potential for propagation of analog video signals. As a result, industry facilities have been serving as ad hoc clearing houses for an ever brisker influx of devices from the high-tech production mills of the photonics industry.

## Cable-designed lasers coming soon

And the confusion can only get worse. In the past two years, engineers have turned up a bevy of useful devices designed for digital telecommunications applications that just happen to work for analog video. But the next two years promise an outpouring of lasers designed specifically for cable TV as AT&T, Fujitsu, Mitsubishi, Ortel, Lasertron and other denizens of the diode domain come to grips with the fact that the CATV market is more than a convenient outlet for a backlog of digitally characterized fiber transmitters.

The good news, of course, is that the new generation of devices is being spawned with the cable operator in mind, resulting in specifications that are germane to the analog world of CATV and in transmitters that were built from the wafer up for the types of lightwave systems operators want. Al-

ready, the new enthusiasm among laser manufacturers for this market has pushed them toward refinements of existing designs and production methods that promise significant performance gains.

In the immediate offing are improvements in F-Ps (Fabry-Perot lasers) and

from digital applications for lasers is no easy process. According to Bob Burroughs, director of product development at Panasonic Technologies, even though top-level management at Matsushita finally became convinced last year that the U.S. CATV market for lightwave products was worth pur-

suing, middle management had to be persuaded before the R&D process could begin.

"Interest in our DFBs with integral isolators has been very high," Burroughs said, adding that "we've been selling them right out of the lab." Nonetheless, it won't be until the end of this year that the factories will be tuned to the search for product appropriate for analog applications. "We're a \$40-billion company," he noted, "and it's hard to coordinate the decision-making process that goes from R&D through manufacturing to marketing."

## A 'real' market?

For those laser producers who were first to recognize an opportunity in cable TV, there's a clear advantage in the early going over those who have just come to see the light. Even though nobody has produced a laser designed specifically for AM transmission, there are efficiencies to be built into the production process when it comes to finding the digitally characterized lasers that will work best for analog. "I'd say that, right now, the race is between AT&T and Fujitsu, when it comes to making the best lasers for cable TV," said the president of a systems manufacturer for the cable industry, who asked that his name not be used. "The others are behind right now, but they'll probably catch up. The word is out that this market is for real."

Fujitsu has just begun producing its F-3 generation of DFBs and G-3 generation of F-Ps, both of which operate at 3 milliwatts, a milliwatt or two above the powering levels of most DFBs and F-Ps currently in the field. The additional milliwatt, assuming all

The good news, of course, is that the new generation of devices is being spawned with the cable operator in mind, resulting in specifications that are germane to the analog world of CATV...

DFBs (distributed feedback lasers) that will add to power output, coupling efficiency and noise reduction. Longer term, the prospects are that ways will be found to ensure cost-effective applications of analog video links in virtually any topology operators require.

## Mitsubishi first on board

An important sign of the shifting strategies among device manufacturers was the recent announcement by Mitsubishi Electronics America that it is offering "a single-package solution for fiber CATV signal transmission with the introduction of two new distributed feedback (DFB) laser diode modules." While various Japanese firms have been quietly exploring the analog application field, Mitsubishi was the first to go public with its effort. Now Fujitsu, which has been highly visible in Japan with its lightwave agenda for futuristic video applications, has decided to devote R&D energies to cable in the U.S. And Matsushita, parent to Panasonic, is on the verge of doing the same thing.

Convincing the Japanese manufacturing giants to shift their focus away

By Fred Dawson, Director of Editorial Development, CableVision Magazine



# The FCC's Got Your Number... Do You Have Theirs?

Signal Leakage from CATV Systems is of major concern to our industry.... As July 1990 approaches the subject will become crucial.

The FCC has mandated July 1st, 1990 as the date all cable systems larger than 1000 subs must comply with specific limits on the amount of signal leaking from a CATV system.

CED's commitment to helping operators and engineers prepare for the future will be exemplified in an entire special issue titled "The Signal Leakage Handbook". The Handbook will serve as a complete reference source, providing practical, system-level applications and valuable information on a variety of CLI-related topics, geared toward July 1990 compliance.

CED's Signal Leakage handbook...

Watch for it in June.

## **CED**

Preparing you for tomorrow...Today

other things are equal, adds 3 dBm to the light signal. The F-3 also comes with an internal or integral isolator, adding efficiency to the process of eliminating unwanted wave forms.

The increasing power levels of DFBs, driven by anticipated demand for ever higher digital transmission rates in telephony, is an important boon for the CATV application. According to David Fellows, vice president and general manager for distribution, headend and

earth station systems at Scientific-Atlanta, firms with new high-power DFBs, capable of operating at 5 Gbits/sec over long-haul telephone lines, are finding the market is soft in telecommunications, leaving them the option to refine their products for analog transmission.

**S-A's 54-channel system**

Fellows said S-A has just produced

its first AM transmission system employing one of these lasers, from an undisclosed supplier, and the results are impressive. Already sold, the system will be used to transport 54 channels over a single fiber from a headend to a distribution hub 20 kilometers away. Fellows said it was too early to provide exact performance specifications, but this channel output for a supertrunking application goes well beyond any AM system yet reported.

"This isn't a 'hero' laser," Fellows said. "We expect more to be available in the near future. This is something our supplier will be able to produce in quantity." While the prices for AM links will remain at the \$25,000-per-link level, Fellows said, the new laser capabilities are making supertrunking in AM a cost-competitive alternative to FM or AML for links under 25 km. "This is where we see the immediate market demand developing," he noted.

But, for cable operators, while the continuing advances in digitally characterized lasers is an important boon to the industry's lightwave agenda, the potential for widescale deployment of fiber appears to hinge on developments now underway at labs that are designing lasers specifically for VSB/AM transmission systems. At least three firms—Fujitsu, AT&T and Ortel Corp.—are moving in this direction, with reports that the industry can expect analog devices to be in production by sometime next year.

**Ortel/Jerrold project**

The Ortel project, aimed at supplying a high-performance analog DFB for Jerrold, involves use of new substrate material that will significantly improve the efficiency of the electro-optical conversion process, according to informed sources. Wim Selders, president of Ortel, declined to discuss design specifics, but said the new laser would be manufactured in a "straight-forward" production process that will result in significant cost reductions, if demand is high. He said the laser, which should be available by year's end, will perform at the levels required by ATC and other MSOs for hybrid fiber/coaxial systems with two-amplifier cascades.

According to David Robinson, director of fiber optic technology at Jerrold, his firm will be rolling out fiber-related product at each of the national cable shows for the foreseeable future. In the offing at NCTA in May, he said, is a

# THE FUTURE

will belong to the supplier  
who shares your vision of Just-in-Time  
Materiel Management,

just as the past was dominated  
by suppliers who adapted quickly to our  
changing market.

Be on the lookout for a new supplier  
with the vision to serve your needs  
imaginatively, through the 1990's . . .

. . . and beyond.

**HUDSON  
SUPPLY COMPANY, INC.**

Your NEW source of cable television products.

- Los Angeles 800-441-0666  
818-913-4134
- Chicago 800-331-2258  
312-640-0355
- Atlanta 800-343-9919  
404-979-9957

Reader Service Number 44



# The Cable Alphabet starts with ABC... and NBC and CBS.

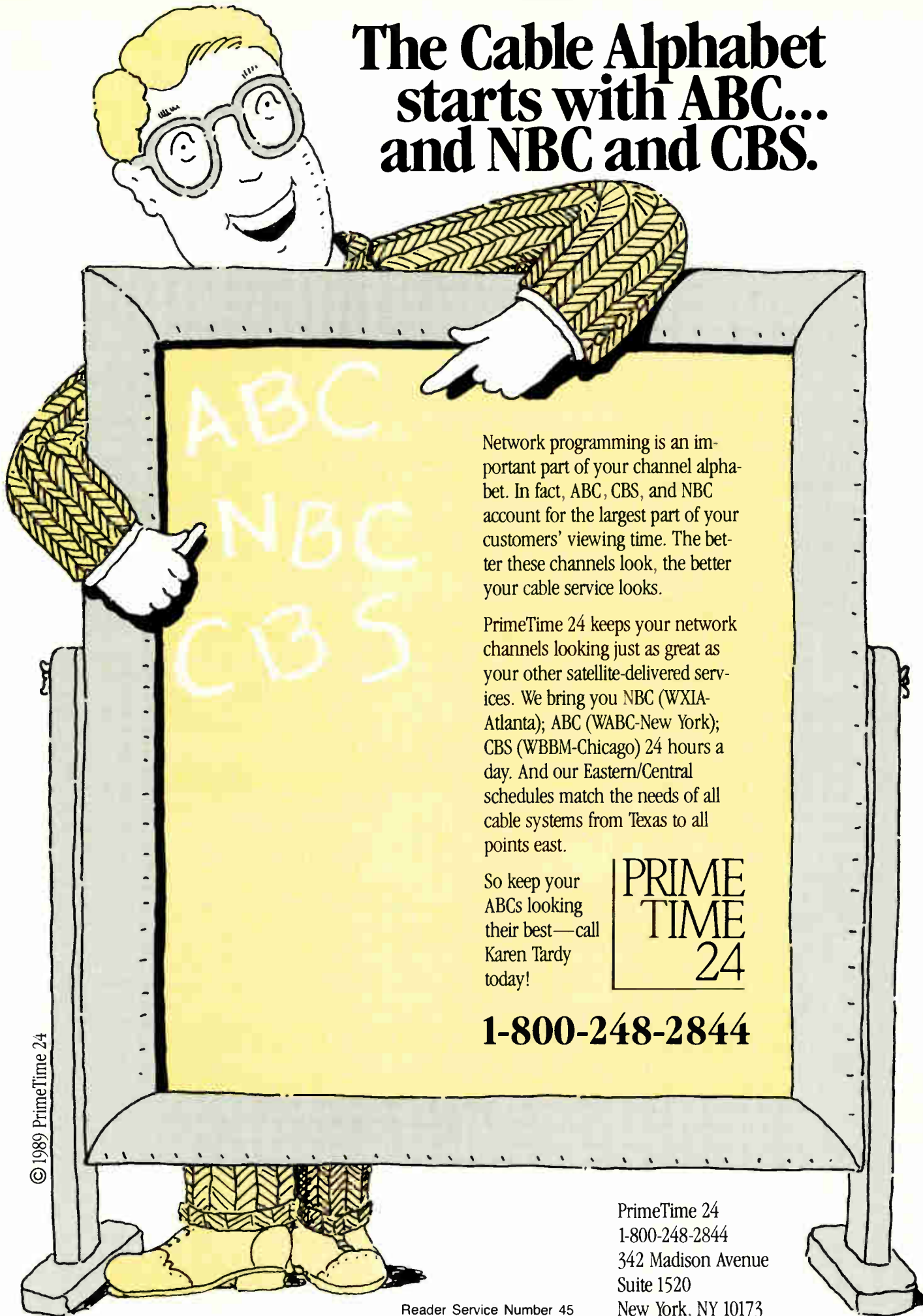

Network programming is an important part of your channel alphabet. In fact, ABC, CBS, and NBC account for the largest part of your customers' viewing time. The better these channels look, the better your cable service looks.

PrimeTime 24 keeps your network channels looking just as great as your other satellite-delivered services. We bring you NBC (WXIA-Atlanta); ABC (WABC-New York); CBS (WBBM-Chicago) 24 hours a day. And our Eastern/Central schedules match the needs of all cable systems from Texas to all points east.

So keep your ABCs looking their best—call Karen Tardy today!

**PRIME  
TIME  
24**

**1-800-248-2844**

© 1989 PrimeTime 24

PrimeTime 24  
1-800-248-2844  
342 Madison Avenue  
Suite 1520  
New York, NY 10173

Reader Service Number 45

multiple-fiber receiver, designed to accommodate the growing interest in AM supertrunking, where more than one fiber is necessary for especially long distances. Until the Ortel project and others like it produce lasers designed for analog, Robinson said, the industry will be confined to use of fiber on a fairly limited basis.

### Converters add channel space

Synchronous Communications President Vince Borelli said his firm is working on a scheme that will permit operators to gain more channel loading capacity from the present generation of lasers by employing up and down converters at each end of the pipe. An important limiting factor in lightwave analog transmission today are second- and third-order distortions. Because fiber doesn't have the bandwidth ceiling limitations imposed by the degradation characteristics of coaxial cable, CATV signals can be transmitted over fiber at very high frequencies, with the result that the second- and third-order "harmonics" are registered at bandwidths above the range of the RF band assigned to cable channels. Thus, with a downconverter at the fiber-to-coaxial

interface, the signals can be sent over coax without carrying any of the harmonic distortions generated by the light source.

Anixter Cable TV, too, is working on ways to facilitate wider use of fiber optics within the limitations imposed by the present generation of lasers. The firm recently announced it would be providing customers systems more precisely suited to specific needs, so that operators will have the option to pay less for performance capabilities that are below maximum standards initially set for Anixter's fiber Laser Link. According to John Egan, president of the CATV supplier, which uses gear supplied by AT&T, the new strategy permits use of a higher proportion of DFBs from any one production run, thereby improving yield ratios and lowering costs.

### Completely new laser

Egan said AT&T, while striving to improve production capabilities and to refine design elements of its digitally-characterized DFBs, is also working on an analog laser with an entirely new design and new substrate material. He said it will be another year to 18

months before this laser is in production, but when it is, he added, it will trigger massive use of fiber by the cable industry.

Adding to the long-term lightwave potential in CATV is the fact that, totally apart from research aimed at designing analog lasers, general research around the globe is continuously generating new designs that offer vast improvements for the future. Of course, along with benefitting cable TV, these efforts also promise to add significantly to the ability of telephone companies to deliver multiple channels of voice and video in the digital mode over fiber.

The expanding list of devices being characterized for the various narrow-band and broadband transmission techniques includes tunable, external cavity lasers and a range of buried heterostructural devices, such as buried crescent, double-channel planar and multi-quantum well lasers. Some of these advances bode especially well for video.

### A new feedback style laser

Hitachi Ltd., for example, has just made public a new feedback-type laser, referred to as "shift-distributed" or SDFB. Built on an indium phosphate

Quality and Performance done  
the Rite Way



offers you more:



- Fiber optic
- Underground
- Aerial
- Cable
- Construction
- Strand Mapping
- Splicing

Rite Cable Construction  
Provides All Your  
Engineering & Construction  
needs, including Fiber Optics

**704/324-9688**

Reader Service Number 46



## \*VIDEOCIPHER II REPAIRS

*Fast Turnaround for Out of Warranty Repairs*

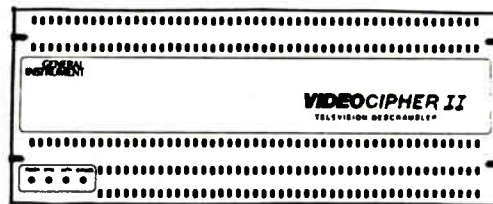

### \*VIDEOCIPHER II DESCRAMBLER REPAIRS

*Fast Turnaround for Out of Warranty Repairs*

*\*\*Turnaround for most units 10 days or less. We do not repair units with loss of memory. Call Cindy for more information.*



1575 N. 105th E. Ave./ Tulsa, Oklahoma 74116

(918) 836-8348

\*VideoCipher® is a Registered Trademark of General Instrument Corporation





# More Power to You.

 **Lectro**®

## More Efficiency.

In response to operators' concerns over skyrocketing utility costs, Lectro designed and delivered the first Super Efficient power supplies. Now, a complete line of Super Efficient products is available for you.

## More Modularity.

Lectro features plug-in modularity so advanced, so simple that maintenance is a snap! Just ask the man in the bucket.

## More Designs

Lectro has the most diversified product line in the business, ranging from 4 amp to 18 amp. You'll find products to meet every application.

## More Service.

We've been powering cable systems for decades, we back up our service and warranties with field and factory support personnel. *A satisfied customer is our most important asset.*

**CALL 1-800-551-3790.**

In Georgia, call (404) 543-1904

 **Lectro**®

More power to you

Lectro Products, Inc.  
420 Athena Dr.  
Athens, GA 30601

Made in U.S.A.

Reader Service Number 48

# Ask for the

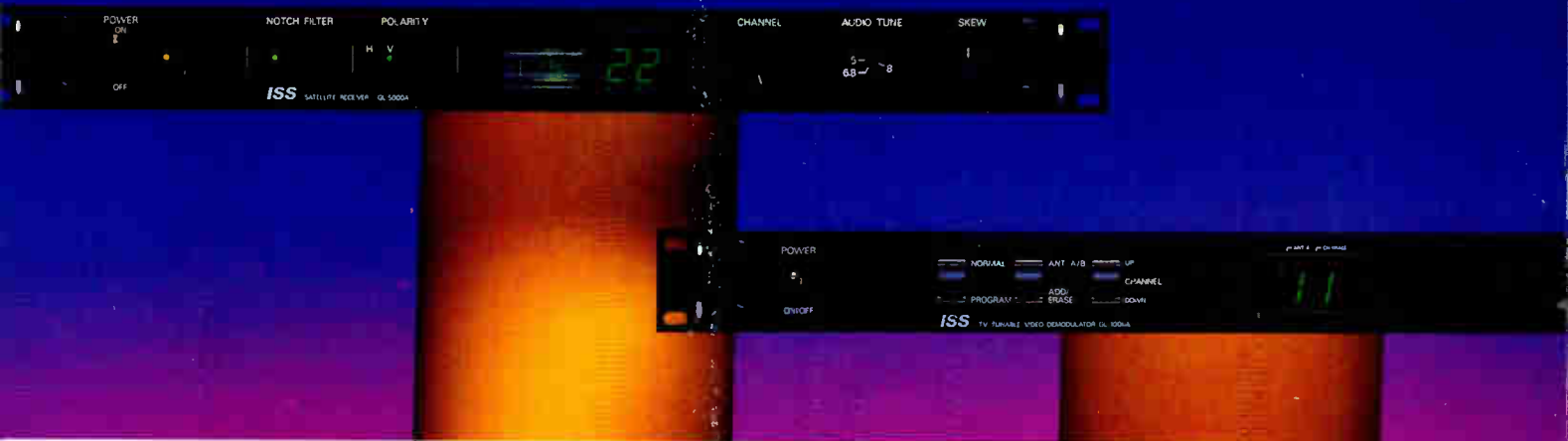

## **You did, and we delivered. . .**

### **Free Modulators.**

When you buy a 550 MHz output converter from ISS Engineering, you receive our modulator free. For about the price you'd pay other manufacturers for an output converter alone, you receive our output converter plus our Series II modulator, all in one space-saving unit—a savings of over \$700.00. We also give you HRC, IRC and T subchannel at no extra cost,\* all user-selectable via convenient, front-panel adjustments. More importantly, our modulator offers you expanded output capabilities from 54 to 550 MHz without the need for comb generators or special output modifications to comply with FCC stability requirements.

### **Equipment That Stays "Legal" Over Time.**

Others may claim to conform to current FCC regulations, but over time, dependent on ambient temperature, their components age and drift. Our components stay legal because we use temperature-controlled oscillators, each with its own oven and FCC-required offsets in both positive and negative

directions. So, frequent adjustments and maintenance are unnecessary and you can feel confident that your ISS equipment will stay stable over the long term.

### **Practical, Reliable Agility, Because You Really Do Need It.**

We at ISS were the first to make agility practical, reliable and compact. Before we introduced our line of agile modulators and demodulators, agility was expensive, cumbersome and often inaccurate. Our decision to specialize in agility, coupled with the manufacturing experience we've developed over the years, has now made us the market leader.

Other companies have fought to catch up with ISS by saying they now offer agile components, but their components are in reality quick, knock-off products, manufactured by an outside source, to which they have attached their labels. One claims that agility is not necessary all the time so it is provided for you only when you need it. If this is true, why has a whole market sprung up devoted to selling "used" modulators?



# Moon.



So when you're looking for agility, look to the leader the other leaders have been following—ISS Engineering. ISS' agile components were chosen by:

- Major cable television and broadcast operations.
- Two of the nation's largest, billion-dollar linear accelerators.
- Numerous federal agencies.
- Networks covering the papal visit and the Reagan/Gorbachev summit.
- The Seoul Olympics.
- U.S. armed forces' shipboard operational and video services.

And we "added life" to one of the largest soft drink manufacturers in the world.

**When you ask for the moon, don't be surprised when ISS delivers.**

For more information, please call or write:  
ISS Engineering, Inc.  
1047 Elwell Court, Palo Alto, CA 94303  
West: Toll-free (800) 227-6288 or (415) 967-0833  
East: Toll-free (800) 351-4477 or (205) 853-6919  
FAX (415) 967-0772

## **ISS**

### **Engineering, Inc.**

**We Simply Bring Communications Down to Earth.**

See us at the NCTA Show, Booth 2627.

\*Series II Plus

substrate (DFBs and F-Ps are typically built on indium gallium arsenide) and employing a completely new design, the laser operates across a 17-GHz frequency band with a 16-Gbit modulation speed.

The goal of the Hitachi designers was to reduce the conversion loss in the electro-optical process so that the laser beam could modulate the frequency at a speed commensurate with the modulation speed of the input electric current. In conventional devices, semiconductor film, with a relatively high dielectric constant, surrounds the light-emitting area, resulting in the leakage of electric current to the film, away from the active layer in the laser. Hitachi replaced most of the semiconductor film area with an organic, polyimide insulation film, leaving a thin layer of the indium phosphate film around the light-emitting area to maintain temperature ranges and other characteristics essential to reliable performance.

With this reduction in the parameter of internal current loss known as parasitic capacity, Hitachi has heightened the frequency modulation band by 10 GHz over conventional DFBs. It has found that a 1:4 wavelength shift ratio in a SDFB results in the highest level of uniformity in the laser mode, which is essential to preventing distortion of the wave slope in transmissions over optical fiber.

#### Old lasers, new applications

Along with the search for new laser designs, there is also a search underway for new ways to use existing devices in lightwave transmission systems. According to Ed Smith, director of research products at Wilmington, Del.-based BT&D (British Telecom & Dupont), which introduced a broad range of advanced devices for lightwave transmission applications in telecommunications at the beginning of the year, the interest in his firm's new components reflects a wide range of strategies under consideration among developers of cable TV and telephone transmission systems. For example, he noted, one customer for BT&D's new tunable semiconductor laser, which offers an extremely narrow linewidth of 100 kHz along with electrical tunability of 25 GHz, also obtained a BT&D lithium niobate Mach-Zehnder modulator, suggesting an application for multiple wavelength topologies.

"We often aren't told what a customer plans to do with our products,"

Smith said, "but one can speculate. In this case, the appeal of the laser may have less to do with its tunability and more to do with the narrow linewidth, which could result in a lower intensity noise for use in an AM system." In addition, he said, there has been interest in the laser for what appears to be wideband or FM analog applications. In this mode, Smith noted, the advantage is "you can obtain wideband frequency modulation with very small perturbations in the drive current," owing to the fact that changes in the drive current alter the index of refraction in the laser cavity, resulting in changes in the propagation frequency within the cavity.

#### Using Mach-Zehnders

Another area of interest for BT&D's new products is the use of lithium niobate Mach-Zehnder modulators in conjunction with continuous wave sources such as YAG lasers. These lasers operate at very high power outputs, opening the potential for driving more video channels at greater distances or over more links per laser than has been possible using DFBs or F-Ps. When an external modulator is applied, the powerful light source is intensity modulated at the output, as compared to the direct modulation applied at the electronic input of DFBs and F-Ps.

Smith said there appears to be a good deal of work underway by some system manufacturers aimed at finding ways to reduce the second- and third-order distortion contributions of the modulators, which is the chief barrier to pursuing external modulation in AM transmission systems.

"We suspect people are putting unique drivers in front of the Mach-Zehnders," Smith said. With accurate predistortion of the modulator signal, he explained, one could precisely compensate for the modulator's distortion contribution.

Mounting interest in the external modulation approach to AM propagation has prompted at least one YAG laser manufacturer to begin scouting the telecommunications transmission system market in earnest. Amoco Laser Co., a two-year-old spinoff of the Amoco Petroleum Co.'s research center in Naperville, Ill., specializes in diode pumped solid state YAG lasers, which currently operate at output powers of 25 milliwatts.

According to Scott Miller, a manager of product marketing, the firm's

current generation of lasers operate across 4.3 GHz of bandwidth at very low RIN (relative intensity noise—a major problem source in analog applications). He said laboratory developments have produced a clean signal to 18 GHz and point to power outputs as high as 175 mw. "Judging from what system developers tell us," he said, "it seems as though this laser is potentially a good product for coupling with optical isolators (to prevent feedback) and an external modulator to deliver 80 or more video channels, with an ability to split the signal over several links. As we reach higher bandwidth and power thresholds, which appears likely very soon, we'll see even higher system performance potential."

A big advantage to the solid state lasers, Miller noted, is the high coupling efficiency, which results in 85 percent or more of the laser output going directly into the coupled fiber. BT&D's Ed Smith also noted coupling efficiency as an important characteristic of YAG lasers, pointing out that the laser's long cavity results in a "very well defined spatial mode."

#### No overnight solution

As intriguing as such ideas are, there are system manufacturers in the cable business who bristle at the suggestion that something is in the offing that will be the "overnight, slambang solution," as David Robinson put it. The name of the game, they say, is to evolve with existing technology in a way that leaves future options as open as possible.

"You can speculate forever on what might work out with external modulation or the next generation of planar waveguide devices or whatever," said one manufacturing executive, "but the fact is, we're seeing real-world, cost-effective applications emerging right now that are going to drive the deployment of fiber in cable TV. And the more such cost-effective applications are found as systems all over the country investigate the existing product options, the faster the costs are going to drop and the sooner the new products are going to emerge."

This message is already being acted on in systems all over the country, with the result that the fiber evolution in CATV is well underway. But don't be surprised at what the innovators might come up with to speed that evolution along. Now that they recognize there's a real market for their components in cable TV, anything could happen. ■



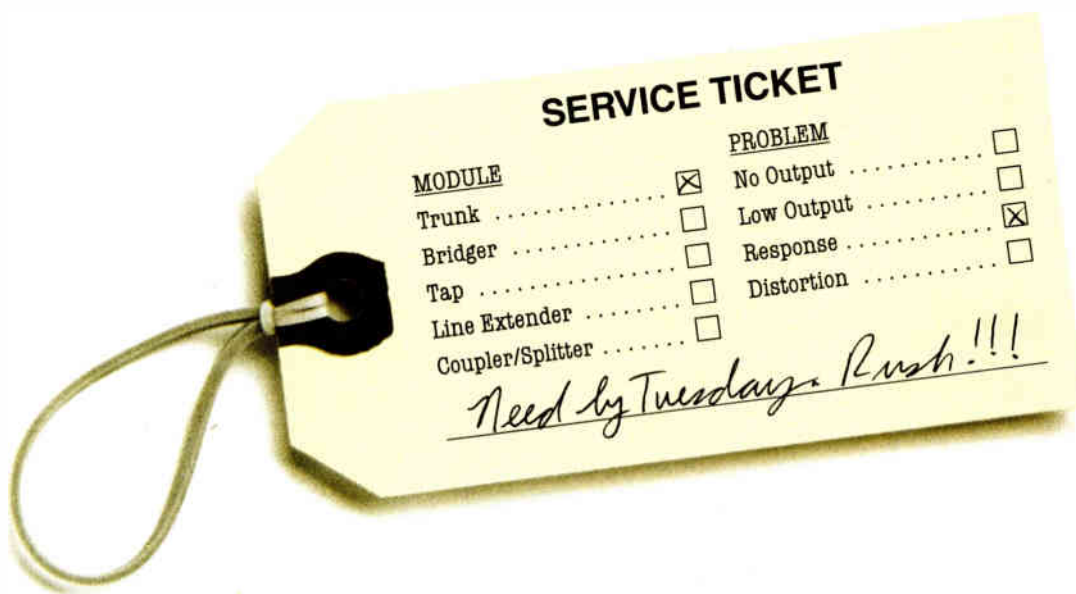

# The last get well card you might ever have to send.

Is there some reason you're sending distribution equipment out for repair and testing?

That's got to be costing you a fortune.

Maybe you didn't realize it, but you can do the test and repair yourself. All you need is a bench sweep system from Wavetek.

We make it simple.

Our 1081 Sweep Generator lets you measure frequency response of active and passive components across any range from 1 to 1000 MHz. In CW,  $\Delta F$  and full sweep modes. Calibrated output is from +60 to -10 dBmV. Harmonic markers adjust at 1, 10 and 100 MHz for wide and narrow band operations.

Our 1076 Comparator lets you measure gain, insertion and return loss. As part of the complete sweep system, it displays both the test channel and the reference channel for easy side-by-side comparisons. Resolution is 0.1 dB.

Our large 1901C Scope Display makes the whole response easy to see.

And since you do the testing and repairing yourself, you save all those outside labor, parts and shipping costs.

You save yourself considerable repair downtime.

And you save yourself from installing bad components by testing them beforehand.

A Wavetek bench sweep system might be the healthiest investment you can make to hold the line on repair and maintenance costs.

Get well soon. Call Wavetek at 1-800-622-5515 for more information and the name of your nearest representative. In Indiana call 317-788-5965.



The do-it-yourself repair kit for CATV components.

Reader Service Number 50

**WAVETEK®**

# Analog CATV optical system weaknesses

I stated in my December column ("One Final Thought," *CED*, December 1988, p. 136) that I had serious problems with both AM and FM analog over optical fiber CATV systems. I mentioned the architecture requirements for cable and fiber usage as well as the very high costs. I also said I felt the two analog systems (AM and FM) were not suited for "fiber-to-the-home" applications and that digital was the only "real" or viable system for the long-term solution.

I made a number of general statements which have caused a bit of comment. So, the following will give more of a technical foundation to explain the weaknesses of analog on fiber. There are huge volumes of technical data on all phases of this technology. I can only hit the high points and provide some equations that partially explain why analog is not the preferred modulation scheme for fiber optics and especially multi-channel CATV.

Most of the following technical information is available from several sources. I referenced, primarily, a fiber optic system design handbook published by Information Gatekeepers, written by Gallawa & Hubbard, 1981.

## Three areas of concern

There are three areas for concern when looking at any optical transmission system, especially any type of analog modulation: a) the laser, b) the fiber splicing and connectorization, and c) the optical detector/receiver electronics.

Briefly, the laser transmitting multiple video channels *must* be ultra-linear and extremely stable. The detector at the receiver must be exception-

ally "quiet" (low noise) and must be "fast" with exceptional responsiveness.

While lasers emit coherent light, by nature they are not exceptionally linear, which could explain why AT&T is asking \$25,000 each for theirs. Manufacturing/fabrication yields have improved by magnitudes over the past years, but linear analog lasers for applications such as ours, (broadband, multiple analog video channel) must

(for our purposes), modulation is accomplished by controlling the drive current. It is possible to go through an external modulation process, but this adds to the cost as well as adding more potential problems.

In analog transmission (CW mode), the laser is continuously operated above the threshold with a proper bias level and the modulating signal is superimposed on the drive current.

For CW transmission the quiescent bias current must be established at a point such that the modulating signal causes an equal plus-minus swing about the quiescent value, and in the most linear range of the intensity characteristic, according to Gallawa & Hubbard.

The modulating signal must vary about the quiescent point over the most linear range of the intensity characteristic and

must be limited in its magnitude to avoid driving the optical source into threshold boundary or overload conditions. (There is something called depth of modulation that we will not get into.)

The fixed bias above the threshold greatly reduces or eliminates transition noise (occurring when the laser crosses the threshold). However, it can and does cause photon-induced noise in the detector at the receiver. The bias must be high enough to prevent clipping on the negative-going limits of the modulated signal. Also, there are substantial current changes due to both ambient and physical temperature changes at the laser.

## Substantial noise

There is substantial noise at the laser threshold level, which rapidly decreases as the drive current increases. However, at high levels of drive current, the laser begins generat-

$$\text{Photocurrent: } I = nqpc / hv$$

$$\text{Responsivity: } R = nq/hv$$

Required Optical Power

$$\text{SNR: } P_o = \frac{FBhv (\text{SNR})}{2nm^2} \left\{ 1 + \left[ 1 + \frac{4I_{eq}^2 m^2}{FqB (\text{SNR})} \right]^{1/2} \right\}$$

Photocurrent of detector proportional to average of carrier power, over period of carrier, where  $hv$  is photon energy, and  $n$  and  $q$  are factors of proportionality.

Equation 1

be individually selected from each manufactured batch. These are DFB (distributed feedback) lasers. They utilize feedback circuits for stability and to provide extra power into a fiber. DFB circuitry makes a much more linear laser. Some designs utilize a second laser in the DFB circuitry as a local oscillator.

## Semiconductors

The lasers referred to are laser diodes (LDs), semiconductor lasers. For our purposes we will discuss what is known as CW (continuous wave) operation utilizing DFB LDs. Simply, the laser remains on (lasing), and the electrical RF signal is inserted. There is also a pulse modulation scheme, which we will briefly describe.

Lasing occurs at a point beyond a threshold value of drive current. A rapid increase in output power is native to the lasing. Most commonly

By Gary Moore, Consultant



# MAKE THE CLEAR CONNECTION

U S WEST Communications Fiber Optic Technology

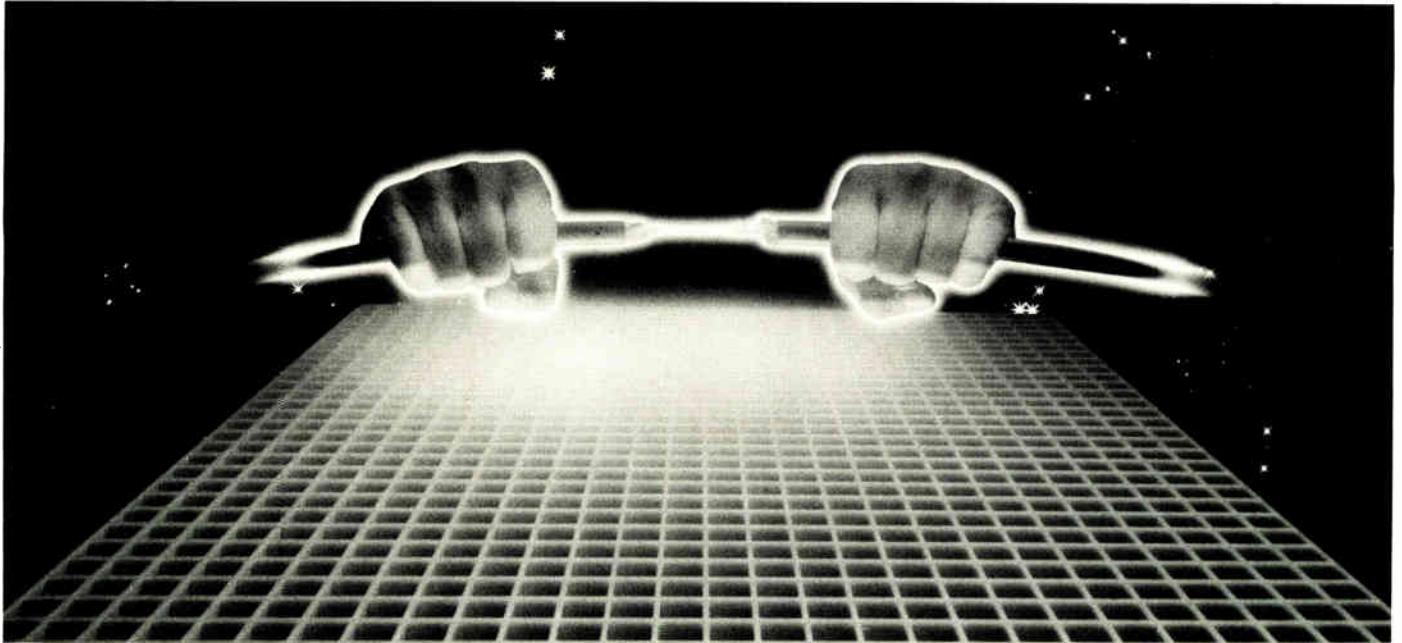

U S WEST Communications is ready to become a player on your team! With our winning combination, you'll keep ahead of the game.

Our experience in fiber optic technology has prepared us to meet the needs of the cable television industry today. Our 14-state region covers one third of the nation, from Canada to Mexico, and includes Arizona, Colorado, Idaho, Iowa, Minnesota, Montana, New Mexico, North Dakota, South Dakota, Nebraska, Oregon, Utah, Washington and Wyoming.

Teaming up with U S WEST Communications offers you:

- A cost-effective solution for your IntraLATA multi-channel video transport needs, allowing you all the advantages of the technology without the large capital required to build your own system.
- Replacement of your AML microwave links with IntraLATA multi-channel video transport, decreasing your system maintenance costs.
- Increased channel capacity and superior signal quality.
- A streamlined ad insertion network, which will lower your costs and improve your advertising income.

Come and talk to us at the NCTA show. We'll be in **Booth #2729**. A representative will be available to talk about our successful ANI Pay-per-view Order Entry product. If you're not planning to attend, you can contact Justin Cislighi at (303) 896-4691 to discuss multi-channel video transport, or Sandy Calvelage at (612) 344-4846 for information about ANI Order Entry.

U S WEST Communications multi-channel video transport – the clear connection!

**USWEST**  
COMMUNICATIONS 

## ANALOG ON FIBER

ing extraneous lasing modes and this noise begins occurring somewhere near 700 MHz. Ironically, the better the quality (purity) of the materials used to make the laser, the more onerous the HF noise. Again we have temperature sensitivity to contend with, which can cause some fluctuation in the output frequency, which impacts on the detector/receiver and the electronics there.

A laser generates heat. It must have special and precise cooling, otherwise

it tends to begin wandering through the optical spectrum. When this frequency drift happens, the laser goes off frequency and begins distorting the signal it is carrying. With analog, and especially AM analog signals, minor deviations by the laser can wreak havoc with the signal. With the primary laser and a second one as LO (local oscillator), the potential for problems multiplies, but the signal is much more stable.

Special cooling circuitry and heat sink mounting is a must for high efficiency DFB lasers. There have been some significant advances in heat sink technology and cooling circuitry in the past year. These contribute to the stability, longevity and linear operation of the laser.

This past fall the news concerning a new heat sink received widespread attention in optical trade journals. This can be taken as an indication of its importance within a laser transmission circuit. If it is that important for digital transmission, one can only imagine how crucial it is to analog—if you don't use the formulas and equations accompanying this article.

The DFB laser is very sensitive to its environment. That is critical for analog signals—much more so than a series of "ones" and "zeros" from digital transmission.

### Dispersion and reflections

The dispersion and delay time of the actual fiber is a minimal problem as far as this discussion is concerned, except when the distance is such as to add to the detector delay time and cause distortion in the video. Yes, it does get complicated. And that's not to mention facet reflections that are especially deadly to AM signals. (See "Reflections in Fiber Optic Connectors and Splices," *CED*, December 1988, p. 66.)

Reflections originating at the laser, connector points (throughout the system and at the detector) and fiber material reflections can seriously deteriorate the signal hitting the optical detector. The reflections contribute to electrical noise leaking through band-pass filters. This can occur at both the laser (transmit) and the detector/receiver locations.

Every splitter, connector and splice adds its own reflections/aberrations to the signal and a cumulative effect occurs. These reflections, or scattering, tend to reduce gain difference, while inducing a stress effect that enhances TM submode oscillation. This research was reported by one of the world's largest electronics and laser manufacturers, NEC.

According to a paper by AT&T Bell Laboratories on crosstalk, the signal degradation appears to be caused—at least partially—by intermodulation distortion. Another AT&T Bell Labs paper identified the receiver electronics immediately following the optical detector as another source of interference and signal degradation from harmonics



**TAMAQUA**  
CABLE PRODUCTS  CORP.

*presents*

**"A Sheep in  
Wolf's  
Clothing"**

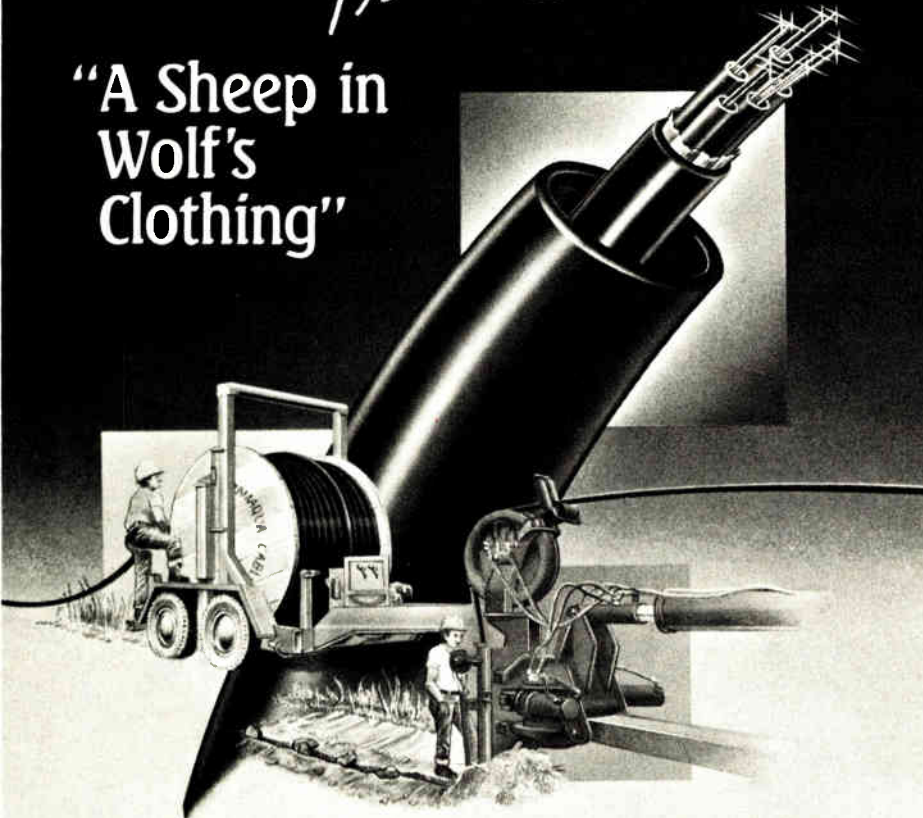

STARRING

## TeleCOMM-DUCT

**THE DUCT SYSTEM** that can be pulled or plowed in long lengths. **PRE-INSTALLED** fiberoptic cable of your choice **WITH** full warranty and testing, yields **SAVINGS** of 25% to 50% in installation costs.

**PRODUCED BY** Tamaqua Cable Products Corporation,  
Schuylkill Haven, PA 17972.

**CALL:** 717-385-4381 **FAX:** 717-385-1092 **TELEX:** 834-573



# TOTAL LEAKAGE PROTECTION



## INTRODUCING *SNIFFER III*<sup>TM</sup>

From signal leakage detection to easy CLI certification, the SNIFFER III now adds the power of microvolt display to the industry standard SNIFFER Leakage Detection System. The new microvolt display joins a host of other SNIFFER III features that will put you in total control of your signal leakage program. Get the details today. . .



## **COMSONICS<sup>®</sup>, INC.**

**An Employee Owned Corporation**

1350 Port Republic Road, P.O. Box 1106, Harrisonburg, VA 22801  
Toll Free (800) 336-9681, In VA (703) 434-5965

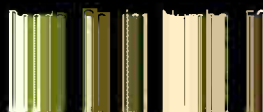

and crosstalk.

A West German research group (Heinrich Hertz Institute for Nachrichtentechnik) observed the same problems and attributed them to channel spacing. They found crosstalk occurring because of overlapping of basebands, with the worst case occurring when the frequency of the local laser was between two of the channels.

### What about laser reliability?

The electronics giant Fujitsu Ltd., has been making advanced lasers for as long as anyone. Recent research reports by them reiterate the industry-wide lack of knowledge concerning the reliability of DFB lasers.

According to the Fujitsu Aging Characteristics study of InGaAs DFB lasers to determine their long-term transmission characteristics, analog transmission is quite vulnerable. (InGaAs is the preferred type of DFB laser at present).

The company discovered variations in operating current during the early stages of the aging tests. Also, it discovered saturation phenomena in the increasing rates of operating current as the aging times increased.

Applying Fujitsu's results to analog

transmission means that during the initial aging period, the frequencies will tend to wander, which hints at a lack of efficiency in the transmitted analog signal, and possibly several trips to the field to re-balance and adjust equipment.

**Analog transmission is characteristically more sensitive and vulnerable to what would be minor problems in digital transmission.**

The test results referred to above do not mean that analog transmission won't work (technically), but, instead, it is characteristically more sensitive and vulnerable to what would be minor problems in digital transmission. Again, we must remember, these are problems under laboratory conditions. They do not replicate "real life" field conditions.

The photodetector's purpose is converting received optical power into an appropriate electrical signal. The fundamental parameters we need to consider are response time, noise characteristics and responsivity.

The photocurrent of the detector is proportional to the average of the carrier power (pc) over the period of the carrier (1/v). This is stated as:

$$I = nqp_c/hv$$

(hv is photon energy and n and q are factors of proportionality.)

Responsivity is given as:

$$R = nq/hv$$

which is the ratio of output current to the incident optical power (amps/watt). This characteristic is linear if the value of n is constant, but n varies with wavelength as well as material, so that linearity varies as a function of wavelength. (Don't forget, actual lased wavelength will also differ due to variations of drive current.)

The optical system is dominated by the noise figure for the detector, but the laser is a significant contributor. In fiber, we have what is known as thermal noise (kT) which is a function of frequency and is prevalent up to about  $10^{12}$  Hz. Then, we have noise that dominates the optical frequency



### CABLE TELEVISION SUPPORT SERVICES

#### OFFERING EXTENSIVE TECHNICAL SUPPORT SERVICES INCLUDING:

- ★ SYSTEM DESIGN (D3 PROGRAM)
- ★ ON SITE PROJECT MANAGEMENT
- ★ TURNKEY INSTALLATION SERVICES
- ★ CLI SURVEYS (INCLUDING MTCE SERVICES)
- ★ FIBER OPTIC AND COAXIAL SYSTEM DESIGNS
- ★ MAPPING SERVICES (BASE, STANDARD, AS BUILT) LINEX CAD SYSTEM

FOR ADDITIONAL INFORMATION, CALL

**1-800-443-0738**

**1-800-782-1202 (MO Only)**

*"Providing Practical, Affordable  
Solutions to Real Problems"*

Reader Service Number 54



**COCHRAN**  
COMMUNICATIONS  
CONSTRUCTION

**GREG WILLIAMS**

A full service communications  
equipment contractor serving  
Southern California and  
Southwestern Arizona with  
the best in aerial/underground  
construction, antenna, tower  
and earth station construction,  
and subscriber installation  
and audits.

36-630 CATHEDRAL CYN. DR.  
CATHEDRAL CITY, CA 92234

LIC. #478543

**(619)328-6778**



# Step up to higher power for longer reach with our latest broadband transmitter.

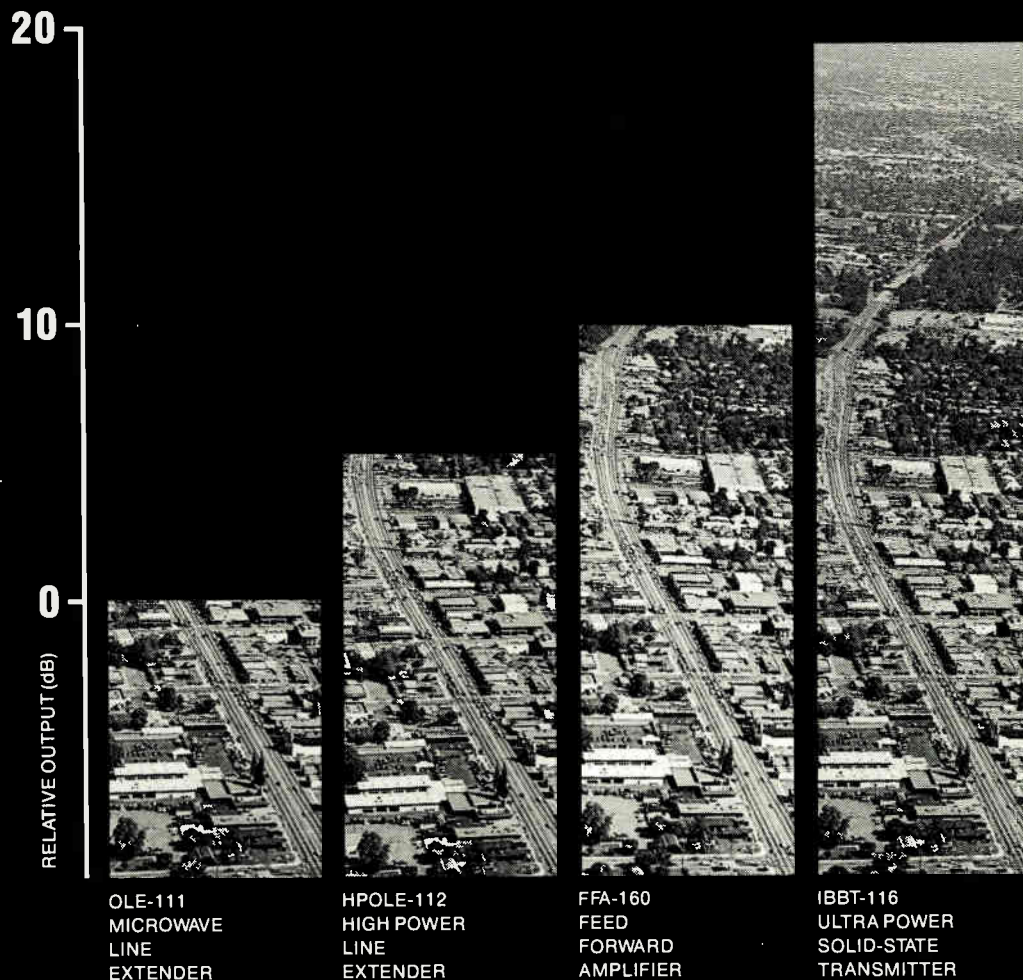

**Hughes' advanced aerospace technology has created the world's most powerful CARS band linear solid state broadband transmitter with 8 dB increased output compared to previous broadband transmitters.**

If you are one of the many resourceful cable operators who recognize the technical and economic advantages of using microwave to reach distant hubs, here's more good news.

A new Model AML-IBBT-116 transmitter is being introduced by Hughes Aircraft Company to close the performance and price gap—a gap that existed between the previously highest powered low-cost broadband block conversion type transmitters and the higher performance channelized types of AML transmitters.

This means you can now use an economical transmitter to transport up to 80 TV channels farther—in excess of 20 miles—signals that can be split for transmission in multiple directions, too. All from one unit which has sufficient power to be located indoors at the main headend, and is easily maintained with open-rack accessibility.

This transmitter incorporates a pilot tone for system phase locking, transmit monitor for monitoring and maintenance, and has built-in self test features.

For more information, contact Hughes Aircraft Company, Microwave Communications Products toll free: (800) 227-7359, ext. 6233. In California: (213) 517-6233. In Canada: COMLINK Systems Inc., Pickering, Ontario, (416) 831-8282.

See us at The National Show, Booth 2027.

Reader Service Number 55

*Hughes AML is more than hardware.*





"CATV in a new light"

## Leading the industry in fiber optic links for

- AM Distribution Systems (550 MHz)
- FM Distribution Systems
- Satellite Antenna Remoting (L-Band and C-Band)

For more information, contact us at:

(818) 281-3636

2015 W. Chestnut Street  
Alhambra, California 91803  
Telex: 752434

Fax: (818) 281-8231

Reader Service Number 56

## ANALOG ON FIBER

ranges and is known as "blue noise."

We have to consider both types of noise when considering a system and its consequences regarding the signals we are transmitting. Utilizing InGaAs in the APDs has greatly improved the efficiency and reliability of detectors, but the same problems still exist.

In analog TV, we think in terms of SNR (signal-to-noise ratio), so to keep things "interesting" we have added another couple of noise factors and terms. The term that will be of key importance is NEP (noise equivalent power). BER (bit error rate) applies to a digital signal and we will try to avoid using it here.

NEP is defined as the rms value of optical power required to produce a unity SNR at the output of an optical detector. All devices can be compared on the basis of NEP.

### Modulation

A continuous wave analog signal can take any value within the high-low limits and is transmitted correspondingly.

A pulse form of analog is merely a sampled form of the continuous signal, retaining the "ability" to take on plus-minus (within limits).

In AM modulation, the carrier amplitude is caused to vary correspondingly with the magnitude of the modulating signal. In FM modulation, the frequency of the carrier is caused to vary continuously with the magnitude

of the modulating signal. During phase modulation (PM), the phase of the carrier is caused to vary with the magnitude of the modulating signal. Intensity modulation causes a linear change in the power output of the device.

A brief word about PCM (pulse code modulation), which is used for some analog transmissions (generally FM) is necessary here. From Gall-awa:

"...if we select  $2^n = 64$  discrete levels in a binary system, then  $n = 6$ . We require 6 bits of information to represent any one of the 64 levels. One amplitude sample in the PCM format requires  $n$  times as many pulses to convey the magnitude of the sample. This requires us to pay a penalty in bandwidth or speed."

PCM is advantageous in that the signal consists of only two levels (binary coding) and the receiver need only to determine whether a pulse at any given time is present or absent (binary 1 or binary 0). This system is highly immune to noise and distortion, including jitter and additive

noise, unlike uncoded analog formats.

Most of the current systems using FM are using between 12 MHz and 24 MHz for each video channel and then clamping them down at the receiver. Remember our noise at 700 MHz? Also, we cannot forget the crosstalk and harmonics we mentioned earlier. If

Equations 2-6  
 $I_{eq}$ : All external noise currents

$$I_{eq} = I_b + I_d + \frac{2kT_{eff}}{FqM^2 R_{eq}}$$

Equation 2

Limiting cases internal noise (APD)

$$\frac{4I_{eq}^2}{FqB (SNR)} \ll 1$$

Equation 3

External/thermal noise

$$\frac{4I_{eq}^2}{FqB (SNR)} \gg 1$$

Equation 4

Noise in signal limits (approx)

$$I_{eq} = 0$$

Equation 5

$$P_o = \frac{Fh\mu B}{n} \left[ \frac{(SNR)}{m^2} \right]$$

(Optimum gain)

$$SNR = n^2 M_o^2 R_{eq} \left[ \frac{q}{h\nu} \frac{m p_o}{16 kT_{eff}} \right]^2$$

Equation 6



# Hi-tech deserves Hi-tech.

## Watchman® II. Superior stand-by power battery.

Watchman® II is the technological leader in stand-by battery power, designed especially for CATV and other stand-by power applications. Watchman II is made of Duratex™. This same tough material is used in GNB heavy-duty batteries which virtually eliminates breakage in the field. The bottom line is, it's the top of the line.

## No maintenance.

Watchman II's Absolyte® sealed lead acid technology means no maintenance, and no maintenance cost. Watchman II never needs watering, there's no acid spillage or corrosive fumes to damage expensive electronics. And because Watchman II is sealed, you can use it in any position, no matter how remote, even freezing will not damage it.

## Premium performance.

Compatible with float service, and unlike most stand-by batteries, Watchman II can be cycled over 250 times. Give your Hi-tech equipment all the power it deserves. Watchman II stand-by power battery.

For more information contact Russ Reynolds, Technical Applications Manager, GNB Incorporated, P.O. Box 64140, St. Paul, MN 55164-0100. (612)681-5000.



Watchman II and Absolyte are registered trademarks and Duratex is a trademark of GNB Incorporated



GNB Incorporated

Reader Service Number 57

## ANALOG ON FIBER

present, they will pass through the clamping despite the normal filters.

### The advent of HDTV

Let's continue looking at bandwidth requirements. If we try to transmit HDTV, we really lose channel capacity. We are (now) placing 16 to 24 FM video channels on one fiber. If a 6 MHz "normal" channel uses 12 to 24 MHz for this transmission scheme, that means an HDTV signal of about 30 MHz will need between 60 and 150 MHz on this same system. In an uncompressed digital format, we allocate 300 Mbt/s per channel for HDTV, compared with 90 to 130 Mbt/s for NTSC. Compressed NTSC video meeting all EIA 250B or NTC-7 specifications is 45 Mbt/s. Some of the HDTV can also be compressed to 45 Mbt/s.

In modern day digital systems with the excellent quality of fiber and the components, there isn't too much problem with signal dispersion until we go to extreme distances (+ 80 km). It does seem to impact analog signals to a much greater degree, even at much reduced outer limits, than digital, however.

In a very simplistic explanation, dispersion (which has several causes)

can be caused by temperature variations impacting on the transmitter and/or receiver. It will cause delays similar to what we know as ghosting in over-the-air signals. This can cause all sorts of signal and timing processing problems, harmonics, crosstalk, etc., as discussed earlier.

By keeping the main signal at a proper power level, this effect can be negated to a great degree. But, since the analog signal is exceptionally susceptible to distortion, the system becomes much more critical. The potential for problems greatly increases.

### Overcoming problems with power

From the information available, the current analog systems are avoiding or overcoming some of the problems with noise and distortion by "blasting" the signals through, and using only a minimal portion of the optical capability. By keeping the fiber runs short, they run little risk of encountering some of the problems mentioned.

Several manufacturers are marketing lasers and detectors with bandwidths up to and exceeding 10 GHz. One would think that with 10 GHz to work with, someone should be capable

of making it carry more than 300 MHz worth of video. Unless, of course, it wasn't technically and/or economically feasible.

The matter is complicated by the cost of an analog receiver for use at the subscriber premise. There is no receiver currently existing that can receive and tune the three to seven decades required for a 30- to 50-channel system. Several companies have estimated that a production quality unit would sell for about \$10,000, if it could be manufactured.

This means if a system installs analog fiber technology, when it wants to carry fiber to the home it must rebuild from the headend and change all the plant, plus eliminate the existing electronics, based on the state of the electronics industry today and the current research.

The bulk of the R&D in fiber transmission is toward totally optical amplifiers and switches, which allow digital transmission of several hundred, up to several thousand kilometers at GBt data rates. Analog is just a temporary aberration in the scheme of things as far as most R&D people are concerned. They won't say it quite as bluntly, but the bottom line is the same. ■

OUR TEAM IS ALWAYS PULLING FOR YOU!



FOR EXCELLENT SERVICE AND QUALITY CATV PRODUCTS  
CALL



**JERRY CONN ASSOCIATES, INC.**

P.O. Box 444, Chambersburg, PA 17201

**(800) 233-7600 (in USA) or (800) 692-7370 (in PA)**



# 1,000,000,000HZ

A Lead Others Must Follow

## INTRODUCING **PATHMAKER PLUS+** A New Standard in 1 Gigahertz Performance

**Plus+ 1 Gigahertz Platform — "Remove Those Bandwidth Handcuffs"**

Offers new options for hybrid/fiber RF architecture

Redefines "wreck-out" rebuilds

Addresses future HDTV requirements

New standards for return loss

**Plus+ Flexible Fiber Optics Tailored To Your System Requirements — "Grow With The Technology"**

Fully integrated AM fiber/RF hybrid systems

Single fiber AM or multi-fiber/multiple octave AM

Fiber optic or RF return path

Redundancy/diversity switching options

Status monitoring via Texscan's Vital Link

**Plus+ Two New Line Extender Amplifiers — "Maximize Your Investment"**

450/550 MHz bandwidths

New economics in feeder line design

Multiple gain versions (32/36/40)

Push-pull and power addition technologies

Unique plug compatible "drop-in" options

**Plus+ New High-Efficiency/High-Reliability Switching Power Supplies — "Stop Burning Up Dollars"**

Lower powering costs

Cooler operation/longer life

**Call us today, 1-800-351-2345.**

DISCOVER THE POWER OF

# Texscan



Leaping  
ahead  
with  
technology

# Pay-per-view television and anticopy technology

It is by now widely appreciated that the "cabling" of America has fundamentally altered the way home entertainment is distributed, given cable subscribers' increased viewing options and created the potential for a revolution in the way video technologies will be used in the home of the future.

One important element in the developments to come will be the maturing of the pay-per-view (PPV) marketplace into a large business. PPV can do what no other mode of in-home video distribution permits and that is allow consumers to choose programs on an event-by-event basis. Consumers will have on demand a range of pro-

tainment and information services scarcely imagined today.

Even with such a large base of impulse ordering systems in place, the full range of PPV programming may not reach consumers until technologies are available to protect PPV program copyrights. It is a simple proposition: given protection, the increased diversity and availability of programming will allow PPV to realize its potential, i.e., dramatic new choices for consumers and a new source of revenue and profits for both copyright holders and the operators of the systems that deliver them to the home.

Macrovision Corp. of Cupertino, Calif. has the technology that meets these copyright protection requirements. The system has

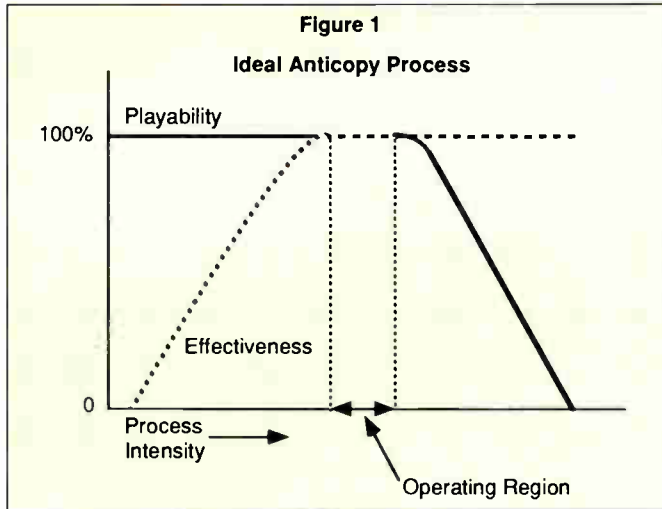
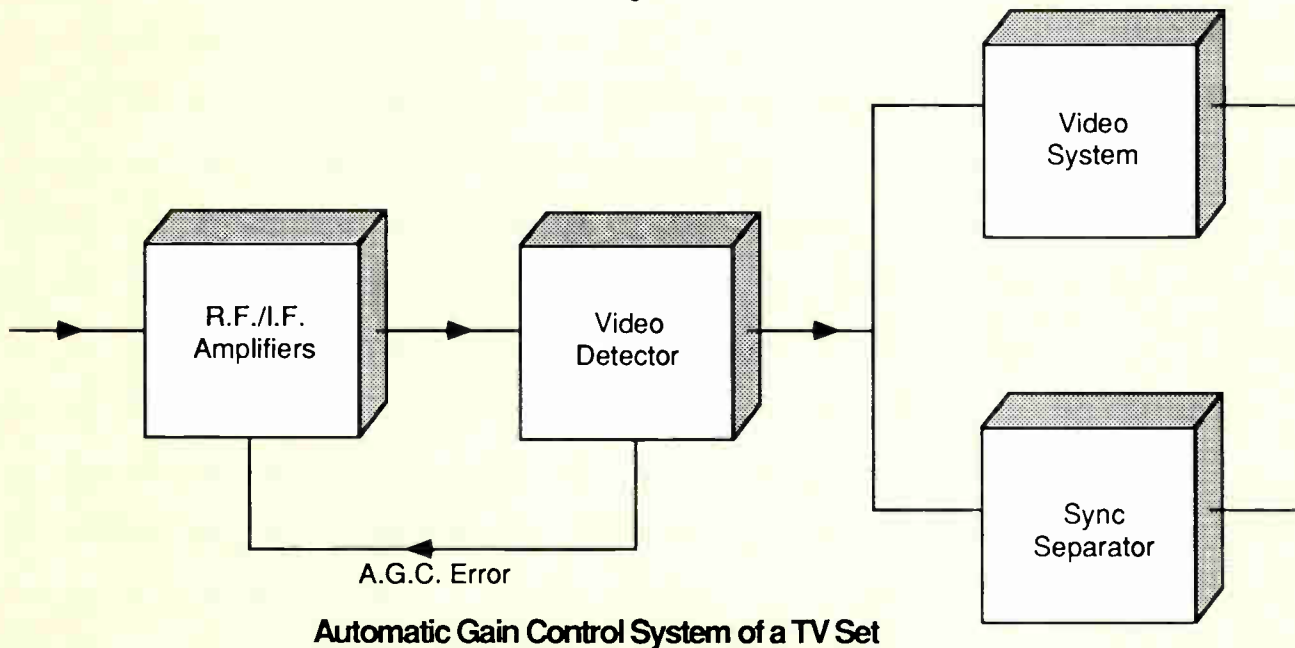

Figure 2



grams not currently available nor likely to ever be available through network or subscription services. PPV promises an array of in-home delivery of enter-

Technology will play a critical role in this development. Addressable, impulse ordering systems have already begun to penetrate deeply into the cable subscriber base. Estimates are that by the end of the 1989, eight to 10 million cable homes will be so equipped.

been in development and tested for more than two years and was designed specifically for PPV applications.

Macrovision controls the application of its anticopy process through its licensing arrangements. The processors are not "for sale;" they are

*By John Ryan, Vice Chairman, Macrovision Corporation*



Fight Subscriber Blues With

# The Dynamic Duo



In the never-ending battle to satisfy subscribers, now you can team up with Zenith's dynamic new SuperSwitch™ and PCC II Multi-Brand Remote Control. No matter what kind of system you have, these two blues-busters are the ammunition you need against the two most common subscriber complaints, "too many remotes" and "unfriendly converters." PCC II turns three remotes into one and SuperSwitch lets pay subscribers enjoy all the features of their cable-compatible sets.

#### Zenith SuperSwitch ▶

With this inexpensive auto-switch the addressable converter is used only on scrambled channels. When watching basic cable, just turn the converter off by remote control and the signal is automatically switched to the cable-compatible TV so all the features can be enjoyed.

#### ◀ Zenith Multi-Brand Remote

The new expanded PCC II now controls over 39 brands of TV's, 45 brands of VCR's and 16 cable converters. It's easy to operate with a one-time setup and dedicated on/off buttons for TV, VCR and cable. Most cable, TV and VCR functions are duplicated including pay-per-view ordering. Best of all, it's very affordable.

To find out how to put Zenith's dynamic duo to work in your cable system write Zenith CATV Sales, 1000 N. Milwaukee Ave., Glenview, IL 60025. Or call (312) 391-7702.



**ZENITH** | cable products

Addressing your future today

## PPV ANTICOPY PROTECTION

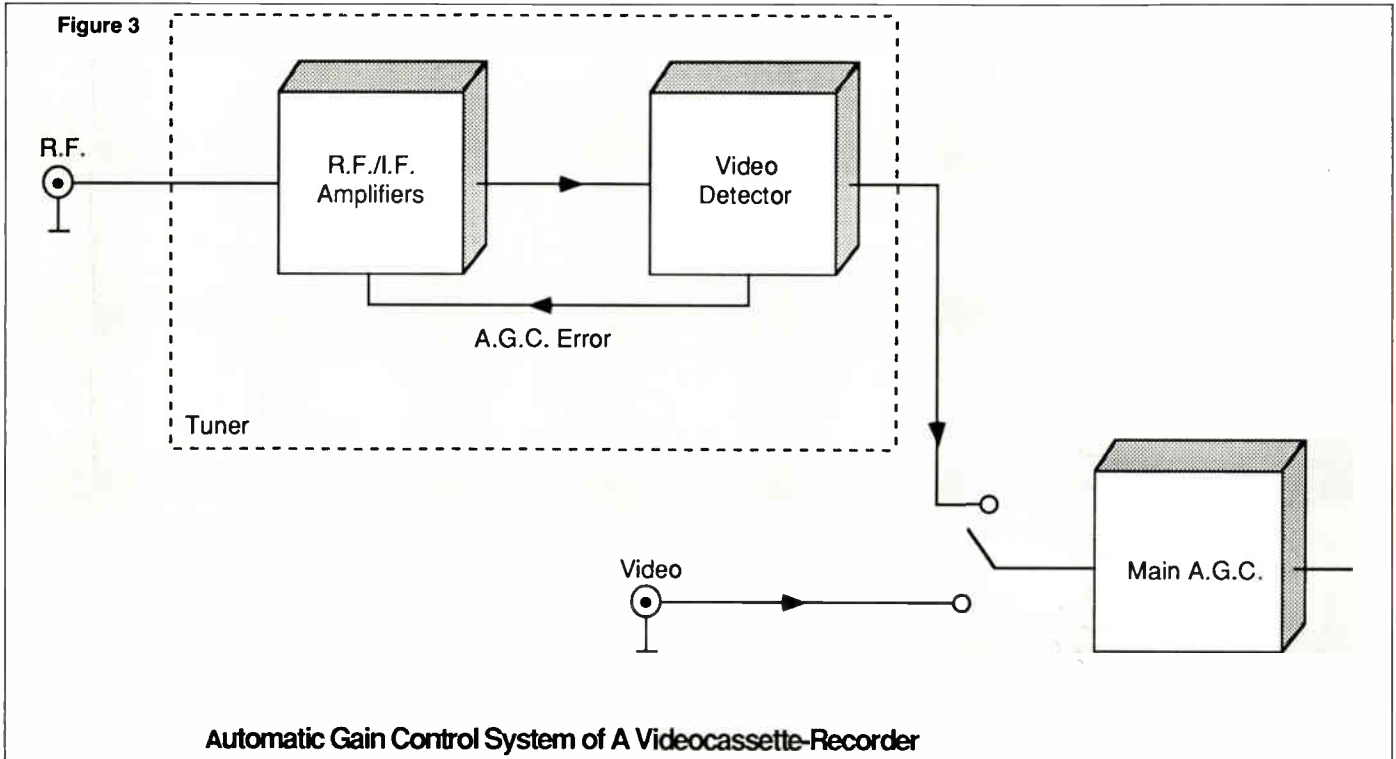

licensed for the sole purpose of PPV anticopy protection. Macrovision will not license the anticopy system for any broadcast or subscription cable application.

### Video anticopy processes

Video anticopy processes work by exploiting the difference between the

way TV sets and VCRs respond to video signals. The trick is to modify the video signal in a manner which has no effect on a TV set but which plays havoc with a VCR. Obviously a copy protected video signal must deviate from the standard NTSC format in order to do this.

Recognizing that a copy-protected signal is inherently non-standard, we

must ensure that it is compatible with all TV sets. This leads naturally to the first of three important parameters by which anticopy processes must be judged.

The first, playability, is a measure of the transparency of an anticopy process. It can be defined quantitatively as the percentage of all TV sets in the marketplace that make acceptable pic-

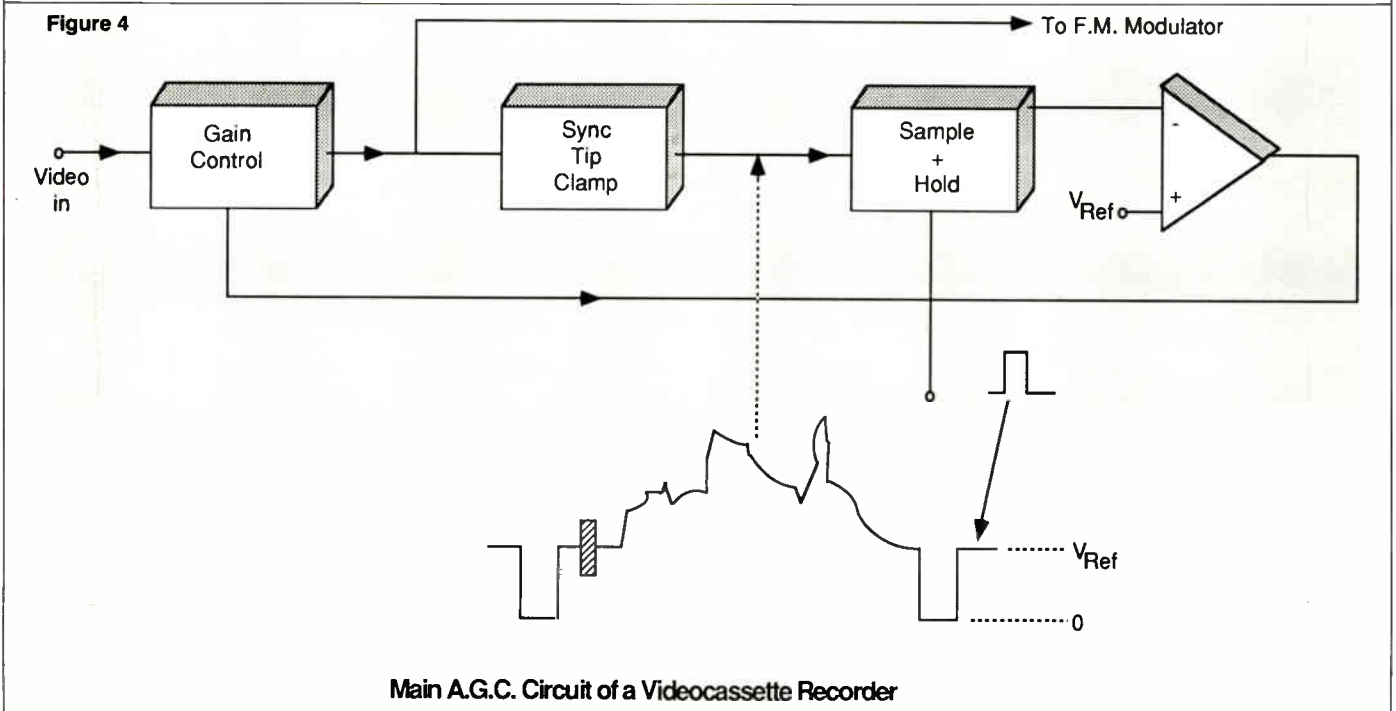



# Run with the Lynx!

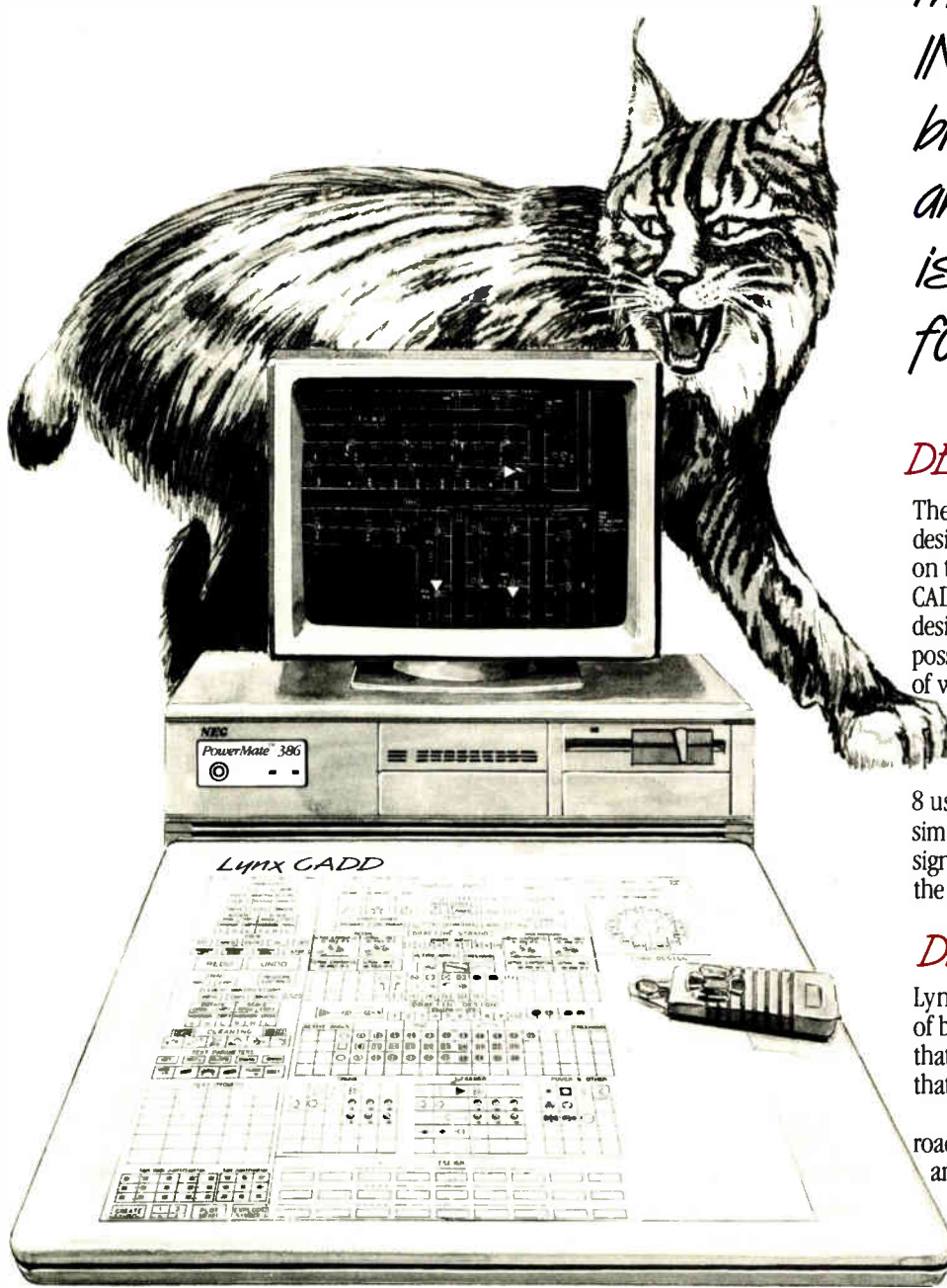

The most powerful  
**INTEGRATED**  
broadband design  
and drafting package  
is now available  
for your PC . . .

## DESIGN . . .

The intelligence of Lynx CADD gives the designer the power to calculate design right on the map. Simply specify the area and Lynx CADD automatically calculates the optimum design for you. Or, explore alternate design possibilities simply and quickly for any type of what-if situation.

Detailed Bill of Materials are produced automatically.

With Lynx CADD, up to 8 user-specified frequencies are tracked simultaneously. And it is possible to monitor signal from a subscriber's house back to the headend.

## DRAFTING . . .

Lynx CADD has taken the basic functions of broadband drafting and created features that dramatically increase the number of miles that can be mapped in a day.

For **base** mapping, Lynx CADD has a road command with easy intersection cleaning and a MAP/CUT command which will automatically divide a topo, utility or tax map into the individually desired maps.

For posting **strand**, commands are available for automatic placement of text for footages, house counts, addresses and pole numbers.

If **design** is posted manually, the SCTE standard symbols are included for your use.

Call (404)448-0977 or (800)333-LCAD today for more information on this powerful PC-based system for broadband design and drafting.

## A.D.S.

Automated Drawing Systems, Inc.

Reader Service Number 61

3150 Gateway Drive, Suite 700  
Norcross, GA 30071

**Figure 5** The Macrovision VHS Process-Line Waveform

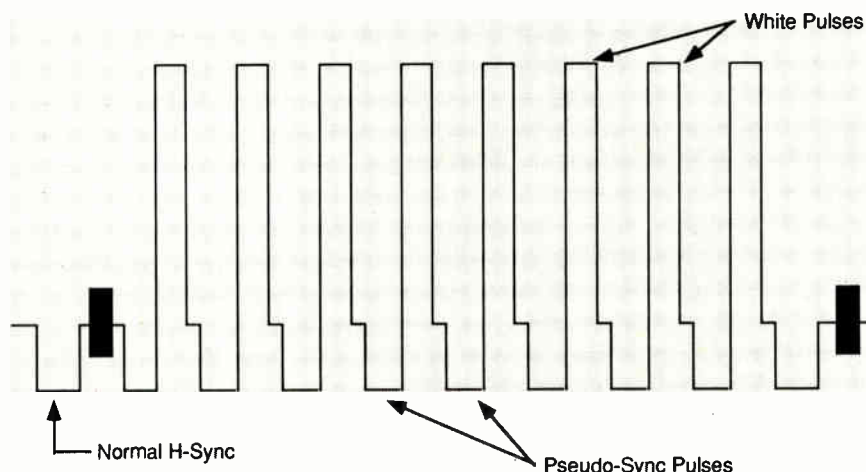

tures from the protected video signal. An ideal anticopy process should have 100 percent playability. The second important parameter of an anticopy process is effectiveness. This is a measure of how well the process prohibits copying. It can be defined quantitatively as the percentage of attempted copies which are either unwatchable or have the entertainment value removed. Again, an ideal anticopy process should have 100 percent effectiveness.

Figure 1 shows how the playability and effectiveness parameters might relate in an ideal anticopy process, plotted as a function of the intensity of the process. (Intensity is related to the extent to which the copy protected signal deviates from the norm.) Note that both parameters are at 100 percent over a wide range of process intensities. Thus it is possible to select a value for process intensity which simultaneously yields 100 percent effectiveness and 100 percent playability.

However, such an ideal process has never been developed and is unlikely to be developed for the following reasons:

- VCR manufacturers strive to make their products as versatile and forgiving as possible—video signals departing widely from the standard signal format can often be successfully recorded.

- Secondly, there are thousands of different TV models in the marketplace reflecting the engineering philosophies and abilities of thousands of designers. Some of these designs are capable of making clear, stable images from sub-standard video signals, while others are barely functional on standard video signals.

From a VCR manufacturing viewpoint, it follows that a very high level of process intensity would be needed to ensure 100 percent effectiveness. From the set manufacturing side, it follows that a low level of process intensity is needed to ensure 100 percent playability. These conflicting requirements dictate the choice of an operating point which favors the playability parameter, since it is widely recognized that while 100 percent effectiveness is desirable, 100 percent playability is *essential* for PPV applications.

The third and last parameter of an anticopy system is security, a measure of the difficulty of reversing or circumventing an anticopy process. An ideal anticopy process should, of course, be infinitely secure, i.e., it should not be possible to electronically restore the video signal to a recordable form or to modify a VCR to allow it to copy the protected signal.

None of the anticopy processes devised to date are immune to being

reversed or circumvented. Unlike scrambling systems, whose security can be made arbitrarily high, anticopy systems must preserve enough of the original signal unchanged in order to meet the playability requirement. Hence a device can always be designed to reverse them.

As a practical matter, however, an anticopy system should be secure enough to effectively resist the level of assault anticipated from the market segment in which it is used.

### Essential features

In addition to providing a high level of playability effectiveness and security, a video anticopy process for use in a PPV system must have these features:

- Be comfortable with the various cable headend scrambling systems and addressable descramblers i.e. the anticopy process must survive the passage through the set-top descramblers and not interfere with their proper functioning.

- Be remotely controllable. The decision to copy protect a PPV movie or event will generally be made by the copyright owner. For complete hands-off operation at the cable headend, the anticopy process should be remotely controllable—preferably through data buried in the incoming video signal applied at the point of origination.

- Be applicable to live and pre-recorded programs.

- Should not impose operational or management burdens—the hardware should be extremely reliable and require as little operational hands-on as say, a distribution amplifier.

Macrovision's pay-per-view anticopy system is a composite of two separate

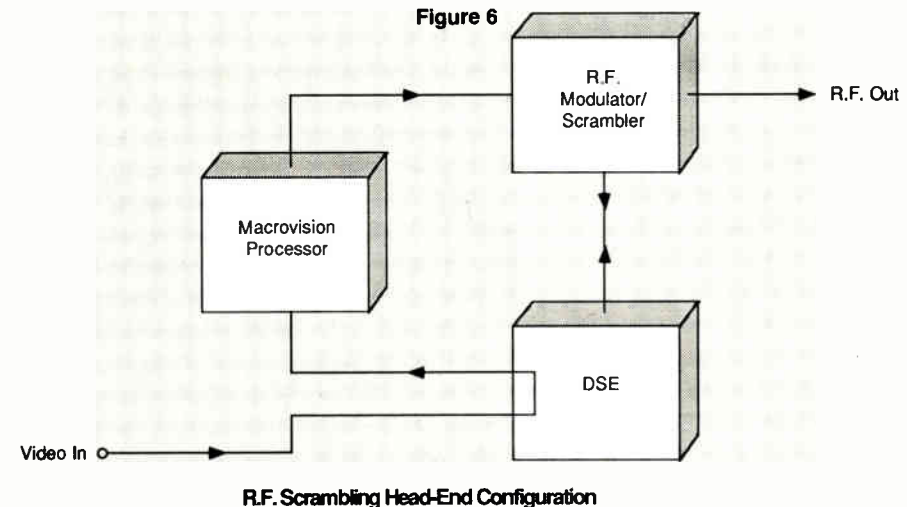



# Call Us With Your Next Order

Head-end

We'll compete with any distributor on price, selection, delivery, and service.

Test equipment

We stand solidly behind every piece of cable equipment we sell.

Distribution

Head-end through drop materials, it performs the way we say, or we'll correct it—immediately.

Taps & connectors

All items carry the manufacturer's full warranty.

Aerial

We stock all major brands, and can tailor packages to your needs.

Underground

Items arrive when you need them, not sooner or later.

Cable

And our engineers and technicians can answer any questions.

Housedrop

Call Cable Services with your next order, or for a free catalog.

Tools and safety

 Cable Services Company Inc.

FAX: 1-717-322-5373  
Toll-Free Service Number 62

## PPV ANTICOPY PROTECTION

anticopy processes based on very different operating principles. One is an enhanced version of the automatic gain control (AGC) process currently being used to protect prerecorded cassettes. The other is a process which attacks the color heterodyne mechanisms of a VCR, producing a series of rolling colorstripes on an unauthorized copy of protected PPV material. This "colorstripe" process is equally effective on VHS, Beta and 8mm VCRs, whereas the AGC based process is predominantly effective on VHS machines.

Combining two separate processes having independent playability/effectiveness tradeoffs allows us to realize an anticopy system having 100 percent playability and a level of

shown in Figure 3. The VCR's RF tuner has an AGC system identical to that of a TV set. The video from the tuner and the external baseband video are fed to a "source select" switch. The selected video is then applied to the main AGC system. This AGC system uses the sync pulse component of the video signal as an indicator of video level, since the sync level is constant and independent of scene content.

Figure 4 shows how the main AGC system works. The video is sync-tip clamped to some reference potential, e.g., zero volts.

A sample and hold circuit is activated during the back porch interval and measures the back porch voltage. Since the sync tips are set to zero volts,

For example, if the back porch voltage was raised to peak white level, the AGC system would decrease the recorded video to about 30 percent of normal. However, such an approach would cause the processed video to be far too dark and virtually unwatchable on most TV sets. This is because the back porch region of the video signal is used as the main black level reference in a TV set. If the black level reference is raised to white level as described above, the black level clamps in the TV set would cause almost total cut-off of the cathode-ray tube.

This problem is overcome by taking advantage of two unique characteristics of the VCR's AGC system. The first is that the VCR cannot distinguish

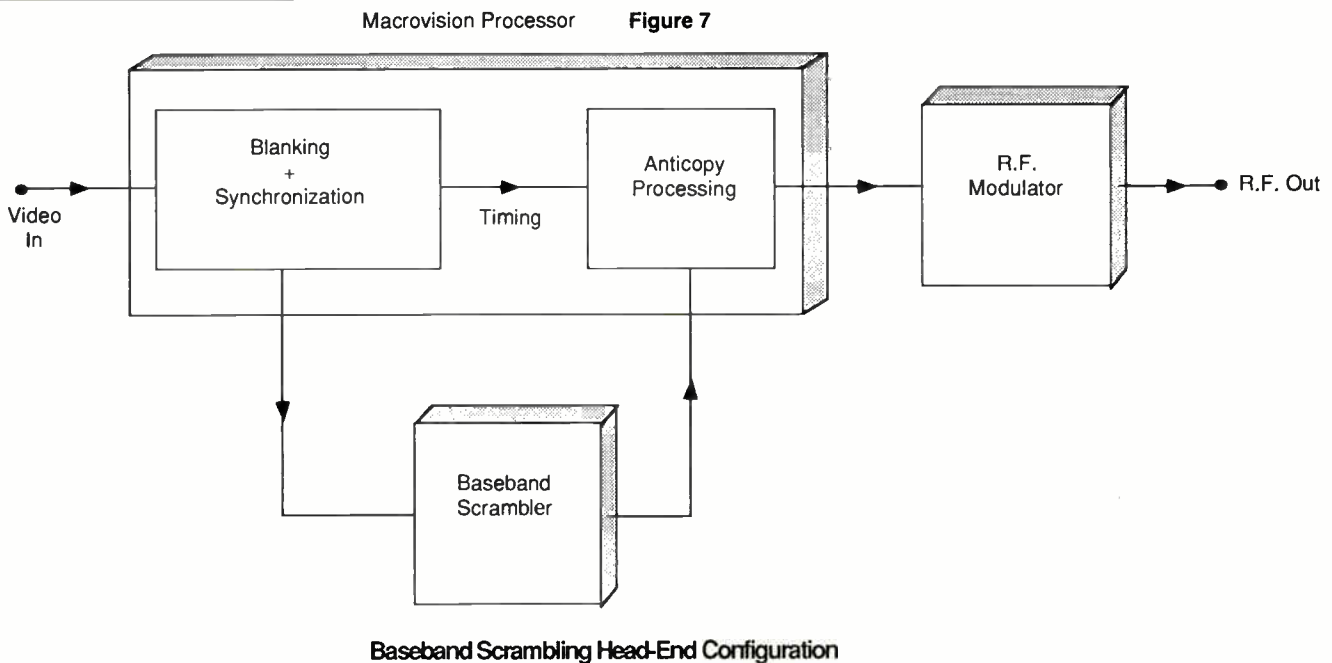

effectiveness approaching 100 percent.

### The AGC process

This process relies on a fundamental difference between the automatic gain control (AGC) systems of a TV set and a VCR. In a TV set, the AGC system measures the DC voltage at the video detector output and uses this as an indication of signal strength. This is illustrated in Figure 2. This AGC system assumes that the RF carrier is modulated by a video signal in the normal manner.

Since a VCR has to deal with either RF signals or baseband video, and further, since the recorded video level is very critical for best performance, a more complex AGC is used. This is

it follows that the back porch voltage is equal to the sync pulse amplitude. This voltage is then compared to some reference value and any difference between the two is used to increase or decrease the gain of a previous amplifier, until this difference is eliminated.

The Macrovision AGC Process is specifically designed to confuse this type of AGC system, leading to degraded recordings of protected material. One way of confusing such a system would be to add large positive pulses to the video signal during the back porch interval, which would cause the AGC system to measure the video signal as being much stronger than it really is. The AGC system would then respond by reducing the recorded video level to a very low value.

between a real sync pulse and any other pulse which goes from blanking level down to sync tip. The second is that the AGC system can be completely confused even if only a fraction of the back porch measurements made throughout the field indicate excessive video level.

Figure 5 shows a line waveform of one line of the field-blanking interval, modified according to the process. The video signal has been modified by the addition of a series of pseudo-sync pulses, each of which is immediately followed by a white pulse extending to about 110 percent. The trailing edges of these pseudo-sync pulses trigger the AGC sample-and-hold circuit, which in turn measures the amplitude of the white pulses.



# The Sound Of Your Future. It's Hear Today!

## The Leaming MTS-2B BTSC Stereo Generator



## Simply The Best Value In Stereo TV Audio:

### More Standard Features!

- Typical frequency response flat out to 15 KHz
- True Automatic Gain Control (AGC) eliminates routine level adjustments
- Stereo synthesizer for ad insertion or mono services
- Your choice of VU-type or LED metering
- Bessel-null test-tone for simple, accurate installation
- Baseband & 4.5 MHz outputs standard (41.25 MHz available)
- Typical stereo separation greater than 30 dB
- Compact, rack-mount design—Just 1.75 inches high
- dbx® licensed companding (true BTSC format)

### Leaming: Cable Audio Specialists Since 1970.

Eighteen years of revolutionary advances, technological innovations, and superior craftsmanship have made Leaming the most respected name in cable audio.

Reader Service Number 63

Representing nearly two decades of research, development, and hands-on practical experience, the Leaming MTS-2B embodies our traditional dedication to electronic excellence.

### Dollar for Dollar, Your Best Buy!

Compare our sound performance, features, and price. We think you'll agree. Nothing else comes close.

For The Sound of the Future—Call (714) 727-4144 Today!



15339 Barranca Parkway • Irvine, California 92718

Also Available Through Major Cable Distributors  
dbx® is a registered trademark of dbx.

Thirty or so such false measurements during each field-blanking interval are sufficient to convince the AGC system that the incoming video signal is three to four times larger than normal. For PPV applications the process uses five lines of the field blanking interval and adds eight pulse pairs to each line. Since these pulses occur during selected vertical lines, they are not visible in the TV picture.

The process forces the copying VCR's AGC system to feed a much lower than normal video signal to its FM modulator. On replay, the VCR regenerates this low-level signal at its video output and also applies it to its internal channel 3 or 4 RF modulator. If this video is viewed on a TV set, the AGC system in the TV set sees a normal RF carrier and is unaware of the low modulation level. Consequently, the video output from the TV's demodulator is very weak and will cause some or all of the following distortions: dim, noisy pictures; partial or complete loss of color; severe color noise; loss of horizontal and/or vertical lock.

This process exploits the fact that while the color-burst component of a video signal is used in a TV set only for subcarrier regeneration, in a VCR it is

also used for timebase error correction.

**The colorstripe process**

The colorstripe process, which gets its name from the alternating stripes or bands of color produced on replay of unauthorized copies, works by confusing the VCR's velocity-error correction system by introducing variations in the color-burst which are not noticed by the TV set's subcarrier regeneration system.

In the NTSC color TV system, the coloring information is transmitted on a subcarrier having a frequency of about 3.58 MHz. The precise color at any point in the picture is determined by the phase of this subcarrier relative to a reference phase, while the degree of saturation of the color is related to the amplitude of the subcarrier.

In order for a TV set to correctly reproduce colors, it needs information about this reference phase. This information is transmitted as a burst of about 9 cycles of subcarrier following the horizontal synchronizing pulse. In a TV set this "color-burst" is used to phase-lock a crystal oscillator, thus generating a continuous subcarrier signal at the reference phase which can

be used to demodulate the color information. It is normal for this phase-locked oscillator to have a fairly long time constant, several milliseconds for example, so as to ignore minor phase perturbations of the color burst caused by noise, etc.

VCRs utilize the color burst to generate velocity error-correction signals to compensate for timebase errors caused by fluctuations of head-to-tape velocity, tape stretch, etc. The velocity error corrector in the recorder's playback system measures the phase of the color burst on a line-by-line basis. Any variation of phase is assumed to be due to velocity errors and gives rise to a correction signal which alters the phase of the chrominance signal in an attempt to eliminate these errors.

The colorstripe process applies deliberate pseudo-random phase perturbations to the color burst component of the video signal to be copy-protected. These phase perturbations are short-term, lasting no more than a few line periods and are such that the average phase of the color burst remains unchanged. Thus, the subcarrier regenerator in a TV set, with its long time constant, will ignore them.

However, the velocity error corrector

**ZANA**  
BORING ATTACHMENT

"At last, a sensible solution to the road boring problem."  
"Light, fast, accurate - an indispensable tool for underground construction."

**SPECIAL SHOW PRICE SAVE \$695<sup>00</sup>**

**ZANA Specifications**

**Bracket and Mounting System**  
Construction: Welded 1/2" Steel Plate and 1/4" Case Hardened Link-Chain

Height: 19"  
Length: Skid 16"  
Width: Skid 10", Mounting Plate 10"  
Weight: 160 lbs. (Including Motor & Thrust Bearing)

**\*Motor - Eaton**  
Type: Hydraulic  
Displacement: 22.5 cu. in./rev  
Flow: Infinite in both direction 137 RPM max @ 15 GPM  
Torque @ 15 GPM: 3150 lb. in. (cont.), 3460 lb. in. (peak)

**\*Thrust Bearing**  
Construction: 6" Tubular Steel with 1 1/2" side wall  
Bearings: 2-3/4" Timken tapered steel roller bearings  
Drive: Positive Splined Drive

**Valve - Detroit (Optional)**  
Construction: 4-way Tandem Center Spool with 3 Position Detent  
Flow: 20 GPM Max  
Relief: 1500 PSI  
Port: 1/2" Dia

**Hoses and Fittings - Aeroquip**  
Valves, Hoses & Fittings available through Dealer or ZANA

\*All Specifications Subject To Change

U.S. PATENT 4,417,628

**Jackson Tool Systems, Inc.**  
(513) 836-2641 (FAX) 513-836-0396

**MAP • a • bil • ity**

from USGS data  
**DIGITAL MAPS**  
for AutoCAD® users

ideal for:

- cable system design
- detecting terrestrial interference
- marketing strategy

includes roads, highways, waterways, powerlines, railroads, landmarks, contours and terrain data.

**A** AMERICAN  
DIGITAL  
CARTOGRAPHY™

715 W. Parkway, Suite A • Appleton, WI • 54914  
414-733-6678



in the color-heterodyne system of a VCR's playback electronics will attempt to eliminate their errors and in so doing will transfer the phase errors from the color burst to the chrominance signal, thus causing severe color noise in the replayed video. In one version of the Process, this color noise appears as about 20 horizontal color stripes, moving up or down the frame. These stripes are complementary in color to the background on which they appear. For example, a green background will show a magenta stripe; a yellow background produces blue stripes and so on. Once an illegal copy of the processed video is made, the colorstripes are embedded in this copy and will be reproduced to a greater or lesser degree of intensity depending on the playback VCR used to view the copy.

### Hardware

Both the AGC and colorstripe processes are implemented on a single 12 inch by 3.5 inch circuit board with a power consumption of less than two watts. Four such boards, supporting four cable channels, can be accommodated in a one-unit high, 19 inch rack-mounting chassis, for multichan-

nel cable head-end operations. Figures 6 and 7 show respectively how the Macrovision system is configured for a typical R.F. and a typical base-band scrambling application.

The combination of the AGC and colorstripe processes in Macrovision's PPV anticopy system provides a level of protection resistant to all but the most technically sophisticated people who have access to professional video equipment. Such a system can be the bridge to increased earnings for the cable industry.

Playability and effectiveness data have been compiled through an ongoing program using local consumer electronics outlets and an in-house lab of nearly 100 assorted VCRs gathered by Macrovision in the course of developing and operating its videocassette copy protection business. Our data show that the process had no playability problems while effectively prohibiting copying. The technical and consumer-reaction data gathered in the course of copy protecting over 125 million videocassettes has greatly facilitated the evaluation of our PPV anticopy system.

The Macrovision system successfully completed the initial field tests on the Gill Cable Network in 1987/88.

The Massachusetts Institute of Technology's Media Lab has recently tested the playability and effectiveness aspects of this process using a fairly large sampling of typical viewers. Though of limited scope, the test found that the copy protected video was judged entirely satisfactory while copies of this video were judged to be of no entertainment value.

Test programs are under way to confirm compatibility with the major addressable scrambling systems. At this writing, compatibility with the Jerrold, Scientific-Atlanta and Zenith systems has been established.

### Uplink compatibility

Working through a copyright holder, Macrovision is testing the compatibility of its system with General Instruments' VideoCipher II and VideoCipher II Plus scrambling systems. Additional tests are also planned to ensure that a copy protected signal can survive the transit from the descrambler to the cable headend scrambler serving the cable company's network. This solution would provide PPV networks copy protection without any hardware at the cable station. ■

# HEADLINE

# BOTTOMLINE

CATV Subscriber Services, Inc. is the bottom line when it comes to providing individual or turnkey package contract services to the Cable and Pay TV industry. CSS offers: mapping, design, construction, installations, audits, sales and marketing along with

various support services. We will be at the NCTA convention in Dallas, May 21-24, so stop by booth #2324, 2325 and we'll show you how to make headlines by achieving a better bottomline.



CATV Subscriber Services, Inc.  
808 Summit Ave.  
Greensboro, NC 27405  
(919) 273-5553

# Automatic order system provides economical PPV TV

**M**ore than 2 million cable television (CATV) subscribers now have the capability of ordering a wide variety of programs by simply dialing a telephone number, without saying a word or planning more than a few minutes ahead. The network used to order the program is part of a system called MACBS® (Multi-Access Cable Billing System), designed and patented by Science Dynamics Corp.

### Economics is the key

Once the public accepted the idea that special programs are worth a few dollars extra, cable companies started to experiment with order entry systems and remote controlled addressable converters in the subscribers' homes. Operator centers were manually organized to take phone orders from subscribers, but CATV system operators found they were labor intensive, and often too slow to allow the customer to order on impulse.

In some cases, two-way technology was installed and overcame the labor intensity and impulse timing problems, but was expensive to install and maintain in dense urban areas and impossible to justify in most suburban and rural areas.

In 1984, AT&T was being split up, and two elements fell into place that made MACBS® (pronounced MAC-bees) a good idea. First, the telephone companies were looking for new revenue sources and providing phone orders to cable TV suppliers became an opportunity to make additional revenue. Second, the breakup had forced into being a Feature Group D channel with very interesting capabilities. ANI (Automatic Number Identification) became available to long distance common carriers as part of a new Feature Group D connection mandated by the

*By T. J. Watson,  
Science Dynamics Corp.*

...the best order rate  
an operator can provide  
manually  
using voice is one  
or two calls per  
minute.

Federal Courts.

### How it Works

The MACBS® equipment is designed to use ANI to automatically identify the subscriber. The CATV company presents a "menu" to the subscriber, usually on a "barker channel" listing

pany. It then re-transmits the selection and the customer identification to the specified CATV order entry activity, acknowledges the subscriber order with a brief voice message to the customer and records the transaction for later bulk billing to the CATV company.

Typically, a local telephone company tariff provides a per call rate charge for the order, however, in some locations a special carrier named "TelVue" also competitively provides MACBS® order services for a negotiated fee.

In the event of an incomplete transaction resulting from an invalid number, ANI failure, faulty transmission, etc., MACBS® will inform and/or instruct the customer with an appropriate voice announcement. Called numbers not found in the MACBS® database are stored in default buffers for later investigation.

MACBS® requires only eight seconds per transaction, while the best order rate an operator can provide manually using voice is one or two calls per minute. Conversely, manual operators who receive numerous orders or who try to rush, often become slow; and

Figure 1

### Feature Group D Domestic Dialing Plan

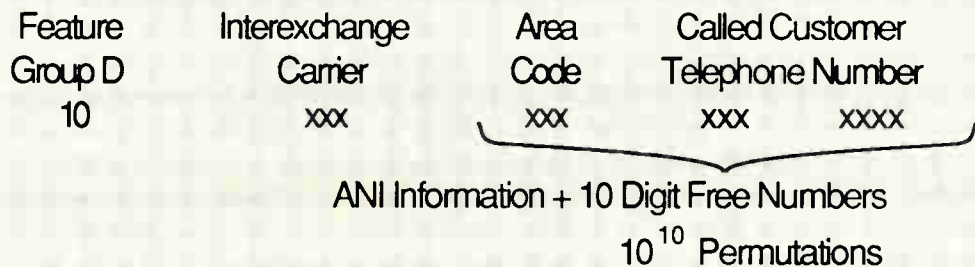

premium offerings; each with an associated telephone number. The customer makes a selection by calling one of the listed numbers using either a touch-tone or rotary dial telephone.

The call is routed to MACBS® through the telephone network via an ANI sending trunk. MACBS® stores the called number as well as the calling number in buffers while it accesses its database to identify the CATV com-

tired operators are prone to impolite tones, if not objectionable or curt responses. MACBS® automatically handles customer calls, eliminating the need for order takers and telephone trunks at the CATV company. Even voice prompting interactive systems require at least 30 seconds per call. A MACBS® system using only 24 trunks can process 9,000 pay-per-view orders every hour. A system with 128 trunks



*Creative  
Management  
Systems*

**V** *alue.*

*It means performance—  
the most advanced subscriber billing and  
management system in the cable industry.*

*It means IBM technology—  
the security of an industry standard and  
the growth potential of IBM's new  
Application System/400™ range of computers.*

*It means reduced costs—  
exclusive features that assure you of the  
highest labor productivity in the industry.*

*It means in-house control—  
flexible cycle billing and  
an array of management  
information and reporting  
capabilities that is the broadest  
ever offered to cable operators.*



The IBM Application System/400 provides a complete family of midrange computers.

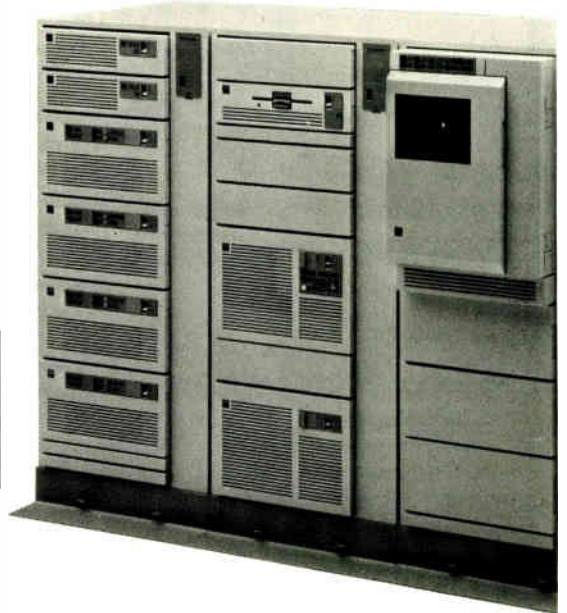

*Value means  
System 1 from CMS.*



**CMS**

**Creative Management Systems, Inc.**

IBM and AS/400 are trademarks of International Business Machine Corporation.

**PRICE PERFORMANCE THAT'S UNMATCHED IN THE CABLE INDUSTRY**

*Headquarters:*  
213 Washington Street  
Toms River, NJ 08754  
(201) 341-6165

*Western Region:*  
50 Francisco Street  
San Francisco, CA 94133  
(415) 362-1345

*Eastern Region:*  
Park 80 West, II, Suite 200  
Saddle Brook, NJ 07662  
(201) 843-4889

For Information call or write the location nearest you, ask for Marketing, Department V.

## PPV ORDERING

never gets tired, and can process 45,000 orders per hour.

### CATV company interface

Links to the CATV companies may be dial-up or dedicated. If a dial-up connection is used, MACBS® will continually monitor transmissions and maintain a connection as long as there is customer activity. Customer transactions transmitted over these dial-up facilities use data sets operating at

digits also designate the called customer's telephone number (within MACBS®, this telephone number equates to the service being ordered).

Another highlight of the Feature Group D service is the identification of the calling customer's telephone number. When the 15-digit number has been dialed and handed off to an interexchange carrier's tandem switch, the calling customer's telephone number is passed along to the interexchange carrier. This service is known

tion such as CAMA (Centralized Automatic Machine Accounting) or TSPS (Traffic Service Position System) type trunks will operate the order entry system.

MACBS® is a modular, microprocessor-based system. The two major components—the trunk subsystem and the data communications subsystem—allow systems to be configured for current needs and expanded when necessary by adding printed circuit boards or trunk expansion units. The

Central Office Figure 2a

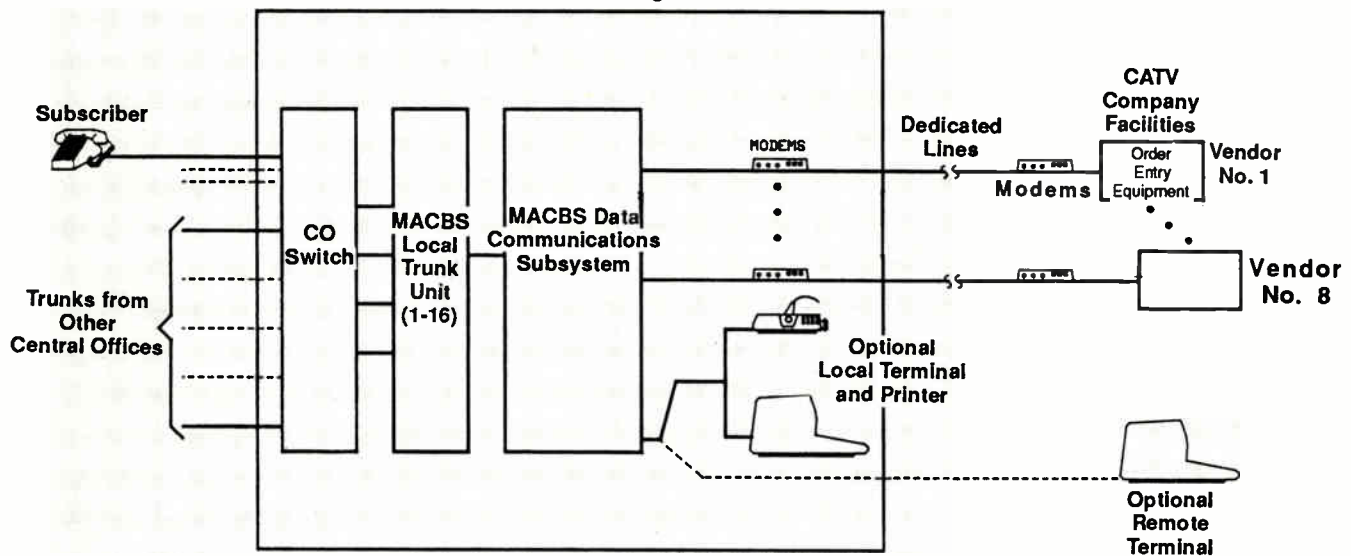

**MACBS WITH LOCAL TRUNK UNITS**

1200 bps. MACBS® can transmit data at higher speeds using dedicated lines and modems to accommodate larger volumes of traffic.

A cable TV company must interface these connection facilities with equipment that can decode the cable customer's billing information from the telephone numbers provided by MACBS®. The cable company will also need to interpret the order information and relate it to the customer's addressable converter.

Figure 1 is a diagram of the Feature Group D Domestic Dialing Plan and how it is transformed into use in accordance with the ordering system of the MACBS®.

The dialing plan utilizes 15 digits. The first two digits, that consist of a one and a zero, when dialed, bring into service the Feature Group D service. The next three digits represent the interexchange carrier, i.e., MCI, TelVue, etc. The next three digits represent an area code. The final seven digits represent an order code. Those final seven

as ANI, and this is the number that identifies the subscriber.

### Other applications

Science Dynamics' MACBS® patent operates with all ANI formats. Feature Group D trunks from tandem switches have been described, but any service that produces calling number informa-

**Another highlight of the Feature Group D service is the identification of the calling customer's telephone number.**

trunk subsystem performs central office trunk interface supervision and voice announcement operations. The data communications subsystem takes the data received from the trunk subsystems (called program numbers and calling numbers) validates and reformats it, and sends it to the cable TV vendors' computers. It also provides access for data entry and retrieval operations. The system also maintains a file of statistical records to validate program numbers and traffic volume such as number of calls, use of trunks, time of message and invalid calls.

To fully utilize a MACBS®, several CATV companies will subscribe to the PPV ordering service. Each CATV company will be assigned a unique main number. Additionally, various telephone numbers or event numbers will be assigned to each event being offered for sale by that particular CATV company according to a planned number code.

The MACBS® includes a data processor and an associated data storage



## PPV ORDERING

memory as well as an optional voice prompting system. The data processor receives and stores incoming calls from the 15 digits of information and ANI information. At this point, the data processor now has information identifying the CATV company involved, the particular event being ordered and the telephone number of the ordering customer.

At this time, an optional voice prompting device will advise the customer that if additional shows are desired, they can be dialed by using an additional 10 digits. The data processor then transmits all data pertaining to a particular CATV company on a telecommunications line to his order entry system. The product code and ANI information must then be converted by the CATV company's computer to produce the identity of the subscribing customer as well as the addressable converter code.

The Science Dynamics patent was originally applied to the CATV impulse PPV order systems, but it covers a multitude of other order entry systems using ANI and the Feature Group D Domestic Dialing Plan as its basic process. Local telephone companies have installed MACBS® in many locations

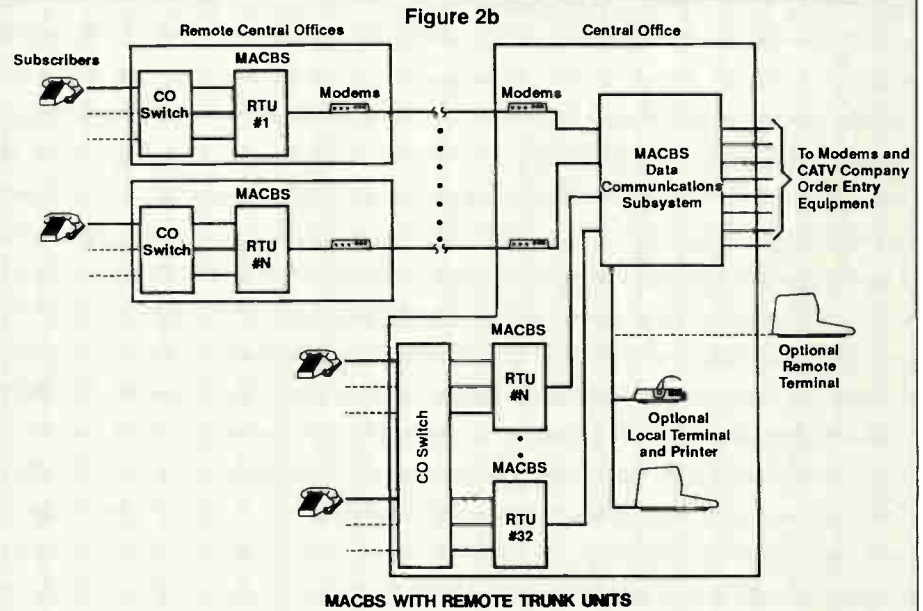

where they and the cable TV companies have cooperated in the provision of the service. Within the year, most of the regional holding companies and many of the independent telephone companies will have filed tariffs to allow PPV TV order entry services to expand. Competitive services, such as

TelVue and other interexchange carriers will expand their systems during 1989 to cover the entire domestic telephone geography. As it grows, it should become even more popular, and, the systems, as they are more fully utilized, will become more economical per order. ■

## Scientific Atlanta

**8500, 8550 & 8580**

addressable  
converter  
repairs

- Repair cost \$16.95 plus parts
- Ninety day warranty on parts and labor
- Repaired with Scientific Atlanta parts only
- 10-15 working day turnaround time

Call for quotes on Distribution and Headend Equipment repairs.

**800-346-3083**  
FAX 219-936-5749

**Midwest  
CATV Engineering**

1818 Went Street Mishawaka, IN 46545

Reader Service Number 68

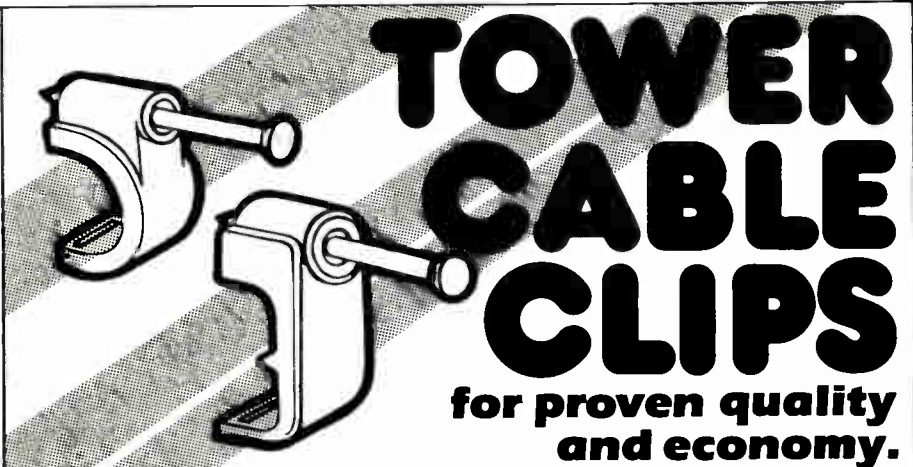

**Tower-the world's largest supplier.  
22 different sized cable clips.**

- Pre-assembled with plated, hardened, masonry nails for hardwood, masonry and cement block.
- Fits most cables from .10" to .63". Available in black, white and grey. For indoor and outdoor use.
- Sure-fit for quick simple installation.
- Tower cable clips distinctive design avoids damage to cable jacket.
- Stocked by leading distributors such as Anixter, Midwest, Graybar, Merit, Resco, The Drop Shop, Cable TV Supply, Signal Vision, TVC Supply, etc.

- Tower, Made in England — Major suppliers to the US CATV industry and the British Telephone Co. for many years.

Write today for free samples and literature.

**WELDONE TRADING CO. INC.**  
3285 Cavendish Blvd., Suite 360  
Montreal, Quebec, Canada H4B 2L9  
(514) 486-2714  
FAX (514) 486-3189

EXCLUSIVE UNITED STATES IMPORTER

Reader Service Number 69

# A unique cable advertising interconnect

A partnership venture between several cable companies is currently implementing an interconnect for the Greater Los Angeles Area of Dominant Influence (ADI, in advertising terminology). The system is unique, but could be cost effectively applied to other markets.

The method employed combines existing technologies in a unique manner to achieve the desired end result. Operation of the system is totally automatic and requires no manpower from the cable company affiliates. Available inventory is shared between the cable company and the interconnect. This sharing of inventory is flexible. Breaks can be alternated or shared within an available time slot.

By Norman Weinhouse, Norman Weinhouse Associates

©From the 1988 NCTA Technical Papers

## Introduction

The Los Angeles ADI represents a huge market for television advertising. It is estimated that over \$1 billion is spent by advertisers in this market annually. Within this ADI there are a large number of cable systems of various size. In the City of Los Angeles alone, there are 14 separate franchises. Regional advertisers have been reluctant to use cable because of this fragmentation and, in general,

Figure 1

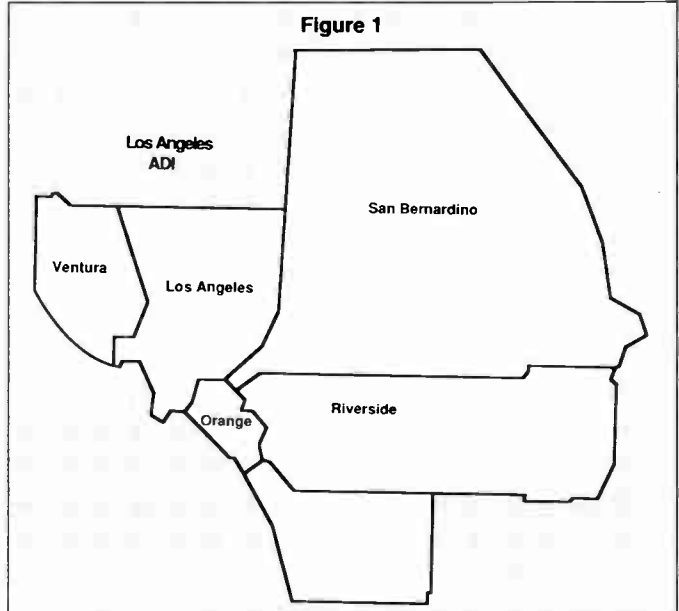
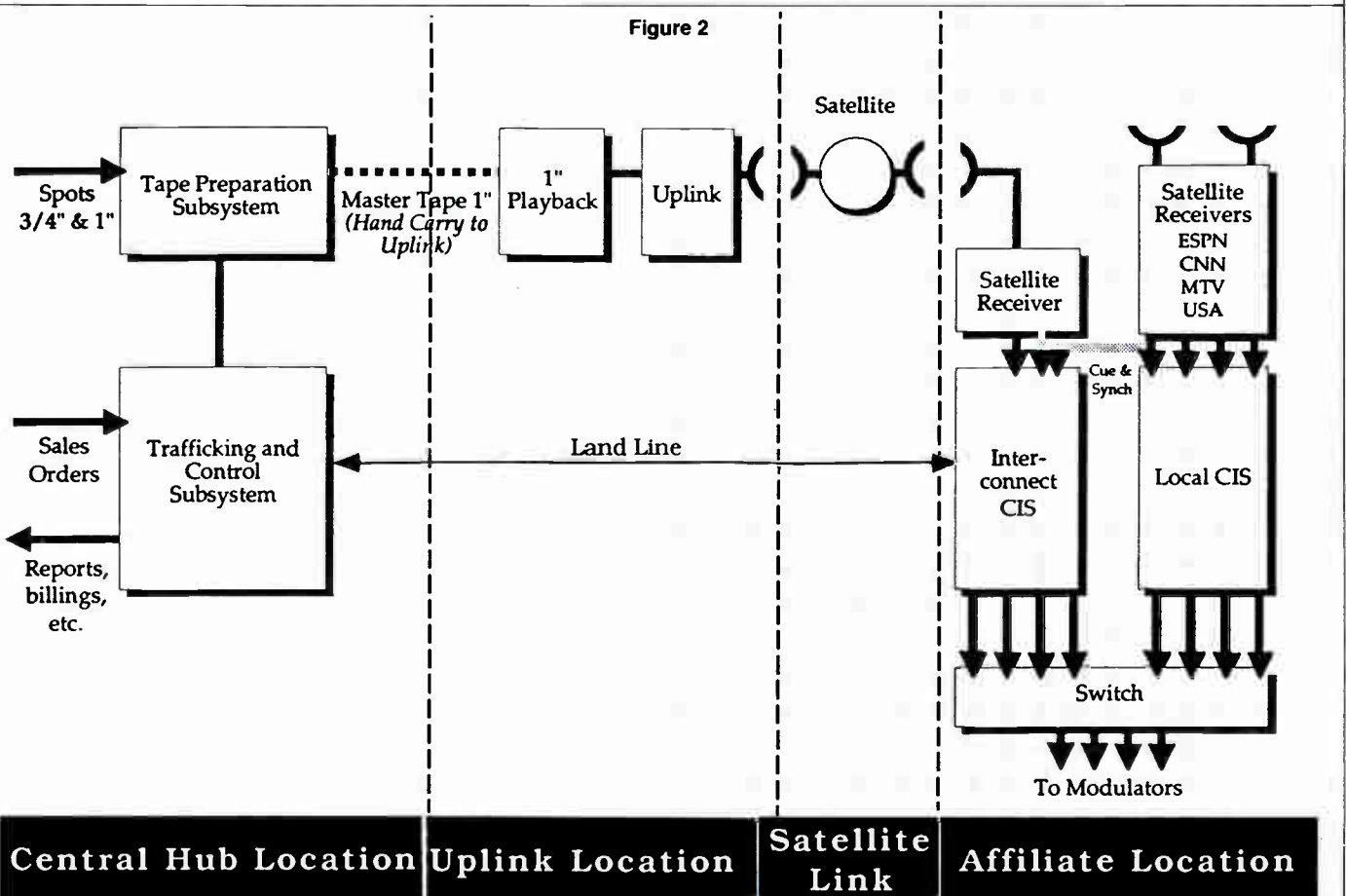

Figure 2





# We carry your size.

CSR-191  
controls one VCR  
for random  
sequential spot  
selection.



CSR-192  
controls two VCR's  
for random or  
semi-random  
access selection.



CSR-294  
controls four VCRs  
for random access  
selection during  
two minute breaks.  
It can insert spots  
on two satellite  
channels at  
mutually exclusive  
break times.



Advertising and engineering managers across the country demand the wide range of capabilities offered by ComSerrer. Key benefits are random access spots, full stereo audio, direct spot search, automatic fail-safe modes, broadcast style switching, selectable end-of-break modes, video verification, advanced tape marking, simplified installation, automatic VCR timing adjustments, auxiliary inputs, external processor loop, preview outputs, multi-tasking operating system and modular design as well as thorough training and support. Our standards of quality and reliability have resulted in the selection of ComSerrer being the commercial insertion equipment choice of 18 of the top 20 MSO's.

We're focusing on your future.

**Texscan MSI**

124 North Charles Lindbergh Drive, Salt Lake City, Utah 84116 / 800-367-6011 or 801-359-0077  
Reader Service Number 70

## COMMERCIAL INSERTION

cable advertising has not been done in a professional manner compared to broadcasters.

Furthermore, this ADI covers an immense geographical area. Figure 1 shows the five counties of Los Angeles, Orange, San Bernardino, Riverside and Ventura. The topography ranges from extremely high urban population density to remote desert and rugged mountain areas. It is obvious that a terrestrial interconnect would be extremely expensive to implement. A solution utilizing the distance insensitivity of satellites is employed in this interconnect. The satellite is used sparingly. Only the spots to be aired are transmitted at off hours for only a few hours a week, thereby reducing the cost of transportation.

### System overview

Figure 2 shows how various elements of the system are connected to form the interconnect.

A Central Hub station is established as business and control center for the interconnect. Each affiliated cable system is equipped with a Commercial Insertion System (CIS) located at the cable company headend. This CIS is in addition to the CIS which may exist to provide ad insertions by the cable company. The central hub and remote

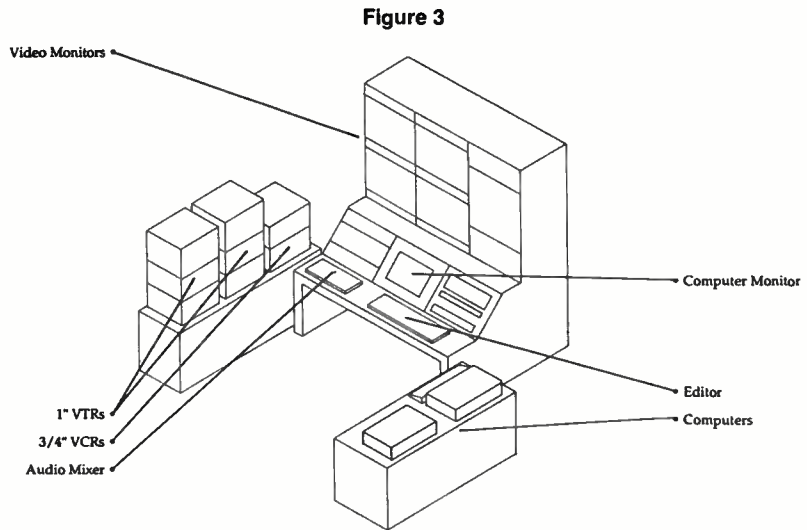

CIS's are connected by telephone land line. The interconnect CIS's are equipped with record/player VCRs rather than play-only VCRs.

The hub compiles a master one-inch tape from spots which are supplied by ad agencies or the advertisers. Periodically, as schedule dictates, this master tape is transmitted by satellite, and recorded by the remote CIS's. This transmission and recording session is done at off hours that doesn't conflict with either normal satellite programming on that transponder or with the

commercial insertion schedule. Insertion into the programs providing availabilities is done automatically on cue in the usual manner. The telephone line(s) are used to download schedules, provide status and verifications in the recording process, provide verification of spot play, and a host of other communications functions.

Initially, four programs for commercial insertion (ESPN, CNN, USA, and MTV) will be implemented. The system software can accommodate up to 20 programs. Additional programs will

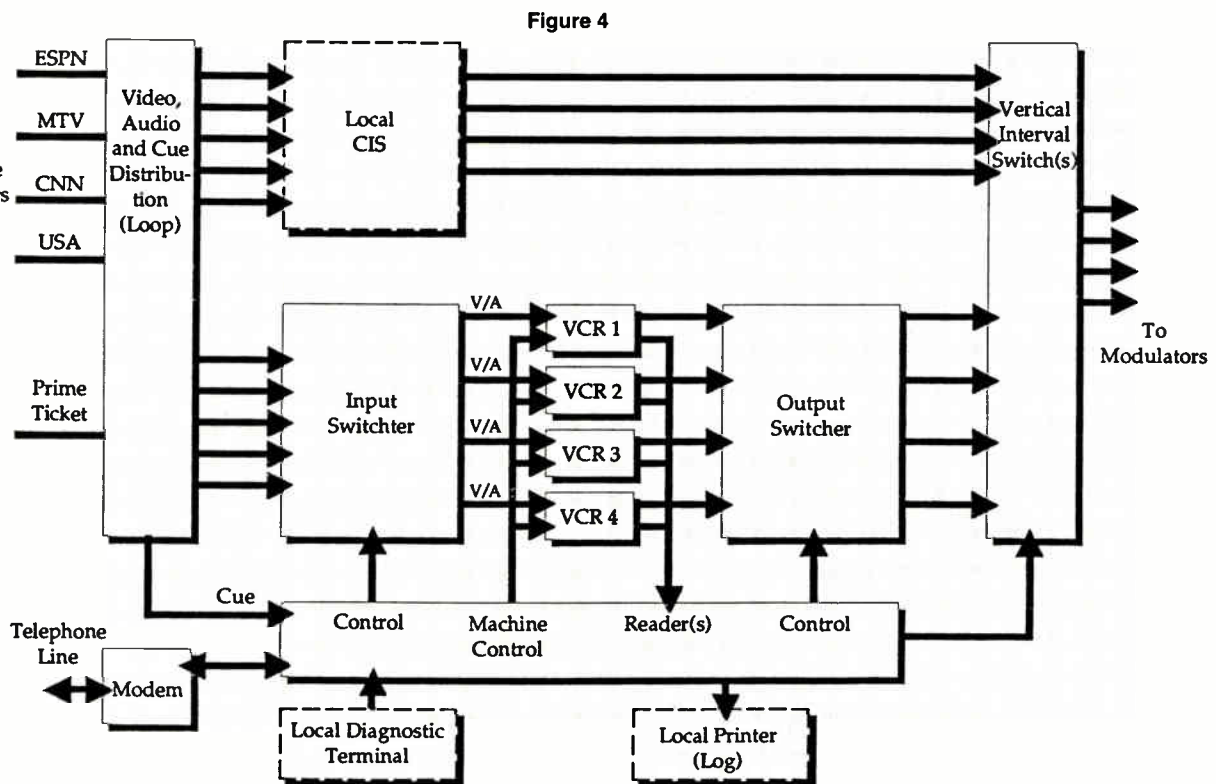



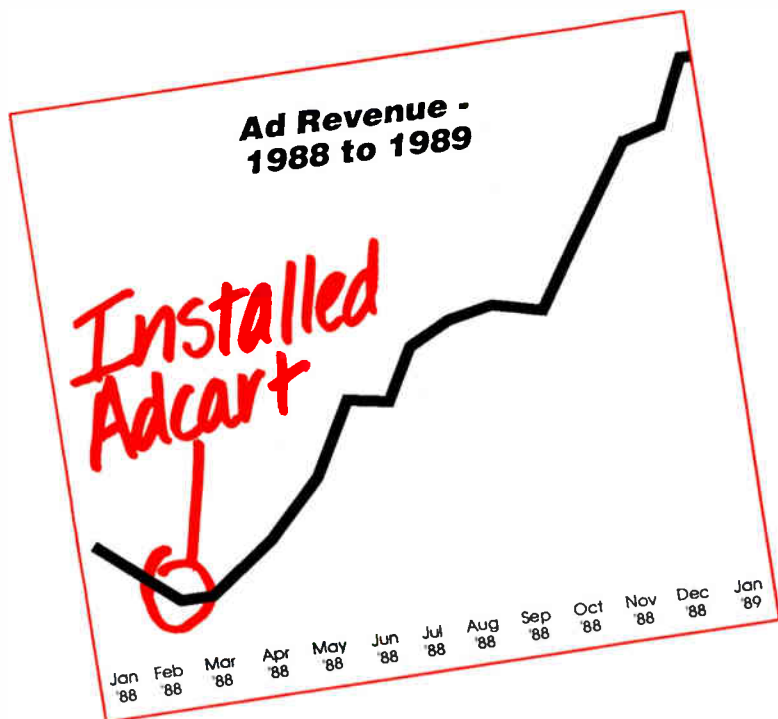

# You Can Easily Increase Your Ad Revenue by Modernizing Your Approach

*...Don't stifle your growth with an obsolete system, specify an Adcart.*

*It's today's front runner and will be for years to come.*



**Maximum reliability and precision for maximum revenue.** The ADCART, an advanced ad insertion system from CHANNELMATIC, is a breakthrough in automation technology.

**Save in labor costs with automation.** Adjustments are made from the terminal, not the racks; less editing is required with a commercial spot reel for each VCR and ADCART's fully automated tape encoding unit.

**From revenue projections to traffic scheduling to client billing, AD MANAGER™** traffic and billing software will tie it all together. Generate logs, daily avail reports in minutes, not hours, billing in hours, not days.

### You'll have these advanced capabilities...

- ▼ Computer-adjusted audio levels
- ▼ Easy keyboard reconfiguration of VCRs and channels
- ▼ Video-quality detection
- ▼ Record capability for automatic local or satellite-delivered spot reel duplication
- ▼ Real-time, multi-tasking modular software
- ▼ Minimal rack space requirements — 50% less
- ▼ Super-tight broadcast audio and video performance specs
- ▼ Extensive local/remote diagnostics from factory
- ▼ Unlimited expansion capability
- ▼ Network program scheduling with a bonus loop

... and many more.



**Also a router, black-out, and headend switching controller, syndex program exclusivity switcher, and program playback system.** Its functions are fitted to your application. ADCART is designed to grow with your system — without locking you into yesterday's technology.

**Increase spontaneous ad sales opportunities with quick, flexible scheduling.** With its state-of-the-art software, ADCART operates in full random access, random pod, or random pod sequential mode.

**Save costs in maintenance and missed spots.** ADCART's spot-to-spot commercial cueing wears VCRs and tape up to 75% less. Power failures are no problem — 100-hour super-capacitor backup assures retention of schedules and logs. When power's restored, the system will auto restart, reboot and recue.

**All you have to know is that you could use more revenue.** Let us handle the rest. We've engineered, designed, and installed hundreds of successful ADCART systems. Turn your design over to us and expect results.

**Call CHANNELMATIC toll-free and request a demonstration and free catalog.** We have over 200 products, including A/V switchers, DAs, custom time/zone switching systems, and much more. In fact, we are the world's largest supplier of ad insertion systems, and we equip whole systems from our own line. CHANNELMATIC knows how to make it all work for you.



**Maximum fixed-position schedules mean increased revenue.** 19,200 spots, 2,400 events, 16-schedule capacity per channel, tailored for your market and budget needs. We have made over 5,000 channels pay for themselves countless times over.



— The recognized leader in ad insertion. More than 5,000 channels in operation —

require additional hardware.

**System description**

**Central hub facility.** The central hub contains two major subsystems: tape preparation and traffic and control. Figure 3 is a sketch of the equipment layout. Professional equipment containing the necessary editing, compiling, library, control and business functions are included. A high degree of automation is employed, such that only a single operator should be required, although multiuser software will allow expansion if required.

The control and trafficking subsystem contains two separate 386 class

is hand carried to the uplink station. The master tape is coded with a header (two minutes maximum) containing a directory of spots with frame code information on the location of the spots. This directory is FSK modulated with error correcting codes on the tape. The frame code data is a numerical designation placed in the video vertical interval at the start and stop frames of each spot. The frame codes are subsequently used at the affiliate location for verification of recording and playback (air).

**Commercial insertion system (CIS).** Figure 4 is a functional block diagram of the interconnect CIS, and Figure 5 is a rack layout sketch. The VCRs used are the Sony 9600 which

have a number of performance enhancements over the previous U-Matic machines. This machine has a faster roll/sync time as well as a faster slew time than earlier machines. In addition, there are the following improvements:

- Improved video performance (SP); 330-line horizontal resolution (4.2 MHz response); 46 dB (min), S/N-color.
- Improved audio performance; 70 dB S/N, using Dolby C encoding—will be used; 2 percent total harmonic distortion; balanced audio—600 ohms, input and output.
- Improved wow and flutter; 0.18 percent RMS.
- Sync input.
- Frame coding

ing session of the interconnect:

- Log of schedule and an approximate time of recording start is sent to all CIS's by land line and entered into the CIS database.
- CIS's confirm and acknowledge Record Sequence Command over land line.
- Cue from satellite feed orders all machines to record mode, rewind and prepare to record.
- Cue from satellite feed orders machines to roll.
- Time code or frame code in vertical interval containing log is stored in CIS memory.
- At conclusion of recording session, a comparison of the recorded tape and the database is made.
- If a malfunction is denoted, a discrepancy report is submitted to the hub via the land line.
- Hub has the option of re-recording on a selective basis to those CIS's where a discrepancy is noted.

**Playback features.**

- Unattended playback—4 channels (initially), using normal cue from program.
- Insertion instructions (log) from Hub are stored in Non Volatile Memory.
- Spot length flexibility—1 second to 1 hour.
- No loss of sync.
- Sharing of breaks and/or split alternate breaks with affiliate.
- Insertion log maintained as completed and transmitted to hub on demand.
- Positive (Frame Accurate) readers for start/stop run of spots for verification.

**Telephone line use**

Telephone lines play a very important function in the interconnect, as can be seen from the description of the recording session and playback operation. After careful study, a decision was made to use dedicated tie lines between the hub and affiliates rather than dial up lines. The modems used are smart modems (up to 2,400 baud rate), and use a communications software package with error correcting protocols.

An advertising interconnect which will inure to the benefit of the cable company partners and the cable company affiliates has been described. This interconnect should get the attention of advertisers and agencies who are accustomed to dealing with broadcast-ers. ■

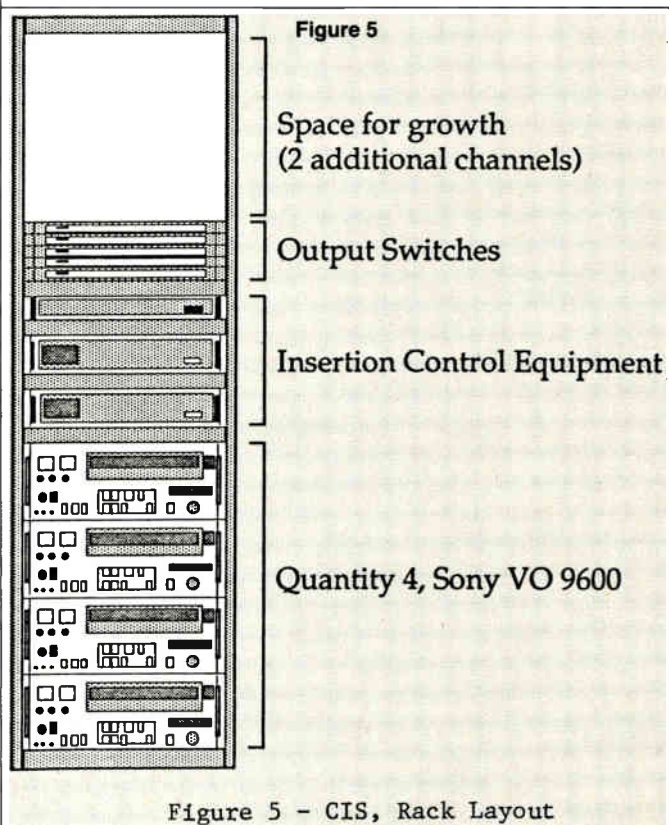

Figure 5 - CIS, Rack Layout

computers for each of the functions. Under normal conditions, one computer is used for system control and the other for trafficking function. In case of a failure in either computer, the other one can perform both functions, albeit at a slower rate. A measure of redundancy is thereby obtained.

The tape preparation subsystem will accept one-inch and/or 3/4-inch spots with either mono or stereo audio from advertisers or agencies and compile a master one-inch tape for subsequent transmission by satellite. At the present time, the uplink is separated from the central hub, and the master tape

is in vertical interval.

The interconnect CIS operates totally independent of any other CIS which the cable company may have for local commercial insertion. A protocol is established such that if a failure occurs in either interconnect or local CIS, signal will revert to the other CIS or to program video. Program video always has priority.

The main functions of the interconnect CIS is given in the following description of the recording and playback process.

**Recording process.** The following sequence of events describes the record-



# Have You Seen Us Lately?

**Perhaps You Should.**

We'll be at the NCTA Show,  
booth #2323, ready to demonstrate:

CLIDE • THE CLI SOLUTION

THE BARKER SYSTEM

YOUR ANSWER TO  
PAY-PER-VIEW ADVERTISING

— Looking forward to seeing you there —

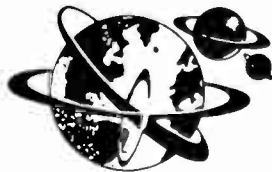

**Telecommunication  
Products Corporation**  
1331 South Seventh Street  
Chambersburg, PA 17201  
(717) 267-3939

# Digital bandwidth conservation

**W**hat is quadrature amplitude modulation (QAM), and why is it of interest? Quadrature amplitude modulation is a technique for carrying two double sideband amplitude modulated signals in the bandwidth normally occupied by one. Because the electromagnetic spectrum is a natural resource with ever increasing telecommunications demands being placed upon it, any spectrum conservation techniques are of potential interest. QAM has long been used to carry the I and Q (In-phase and Quadrature) chrominance signals on NTSC's 3.58 MHz subcarrier and is currently important for two developments—AM stereo and high definition television—operating in particularly crowded bands.

This article's purpose is to visualize, with as little mathematics as possible, exactly what happens in QAM and how we're able to put two signals in the space previously required for one. To begin, we know that amplitude modu-

lated information can be recovered without them. In fact, single sideband (SSB) does exactly this. QAM eliminates the carriers but retains both sidebands for each signal. Each signal is "double sideband suppressed carrier" (DSBSC).

## Amplitude modulation

First, let's look at an amplitude

modulated signal. We're familiar with the frequency domain plot in Figure 1, showing the spectrum of a carrier at frequency  $f_c$  modulated by a single sinusoid of frequency  $f_m$ .  $A_c$  represents the amplitude of the carrier, and the amplitudes of the lower sideband at  $f_c - f_m$  and the upper sideband at  $f_c + f_m$  are given by  $\beta A_c / 200$ , where  $\beta$  is the modulation percentage. Removing the carrier creates a DSBSC signal. This modulation technique costs us something: To detect DSBSC, we can no longer use simple envelope detection with a diode and a low pass filter but must synchronously detect the signal by reinserting the carrier, with the correct frequency and phase. In fact, it was the difficulty and cost of carrier regeneration in vacuum tube days which prevented more widespread use of suppressed carrier systems. If the inserted carrier's frequency is not correct, two signal frequencies—one from each sideband—will be demodulated, instead of one. If the inserted carrier's phase is not correct, the amplitude of the recovered signal will fall off by the cosine of the angle between the modulating carrier phase and the demodulating carrier phase, e.g., with a phase error of 10 degrees, the recovered signal will fall by 0.1 dB; with a phase error of 80 degrees, the recovered signal will fall by 15 dB; and at 90 degrees, none of the signal will be recovered.

But, more important than the loss of the desired signal is the fact that the phase error in the reinserted carrier

## BACK TO BASICS

*Although digital technology is seen by many as an untapped resource for the CATV industry, the greedy demand it places on bandwidth can be a potential nuisance. In this paper by Sherwood Campbell and Archer Taylor of Malarkey-Taylor Associates, a technique of bandwidth compression, quadrature amplitude modulation, is discussed as a method to effectively use spectrum allocations.*

Figure 1

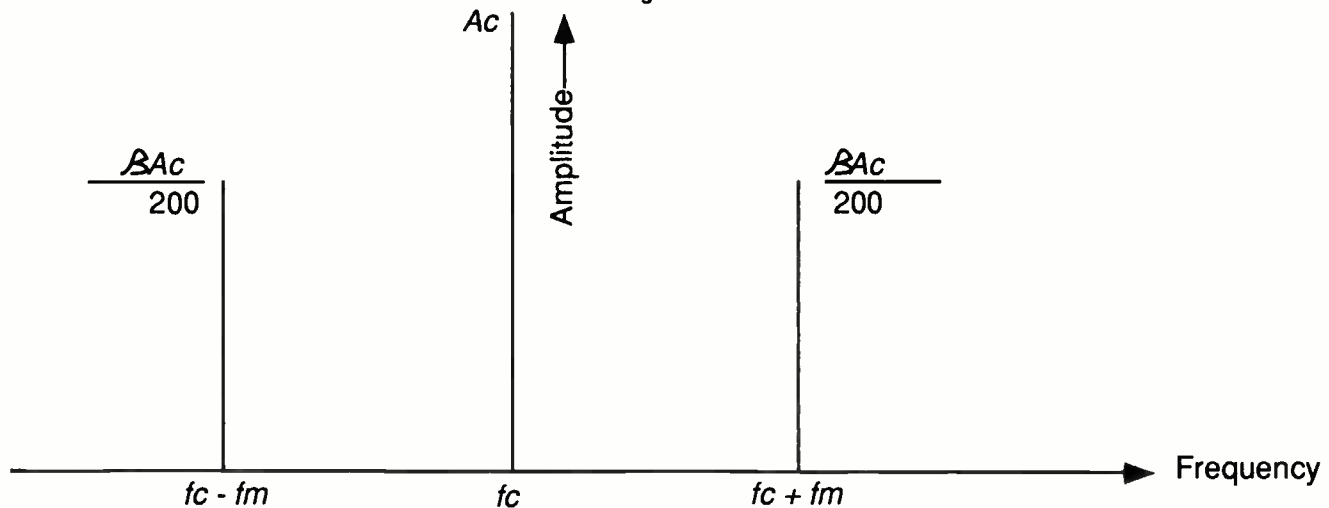

lation is wasteful of spectrum and power: the carrier and one of the sidebands are redundant, and the trans-

mitted information can be recovered without them. In fact, single sideband (SSB) does exactly this. QAM eliminates the carriers but retains both sidebands for each signal. Each signal is "double sideband suppressed carrier" (DSBSC).

This modulation technique costs us something: To detect DSBSC, we can no longer use simple envelope detection

will cause it to demodulate some of the unwanted, quadrature signal. For example, although a phase error of 10 degrees results in a reduction of only 0.1 dB in the desired signal, it causes an increase in the undesired signal from a theoretically infinite rejection

By W. Sherwood Campbell, P.E. and Archer S. Taylor, P.E., Malarkey-Taylor Associates, Inc.



# ARVIS™-2000

## AdView

### Now You Can Create Broadcast Quality Spots On Budget—In Minutes!

The new ARVIS-2000 AdView desktop ad creation system enables even the smallest operator to enter the lucrative local advertising market by offering print advertisers the impact and frequency of television at competitive costs. AdView is so simple anyone can learn to create brilliant, broadcast-quality spots in minutes. And it's so inexpensive any operator can afford it.



- **Easy To Operate.** The AdView system enables anyone to create broadcast-quality spots from photographs or other graphics quickly and easily. Its user-friendly 'point-and-click' graphic interface has been proven in consumer software. Anyone can learn AdView in minutes!
- **Easy To Afford.** The basic AdView system consists of a CPU workstation, workstation monitor, color output monitor and proprietary AdView software. You can get started with AdView for a lot less than you probably think. So the system can pay for itself in a very short time.
- **True Broadcast Quality.** Interactive Picture Systems, Inc., creator of AdView\* software, has generated graphics for NBC, CBS and national cable networks, and for such national advertisers as Apple Computer and Campbell Soup. True broadcast quality means added impact and value for local advertisers.
- **AdView Grows With You.** As part of the growing ARVIS family of products, recognized as the best in video automation, the AdView system is fully expandable to include remote play, full-motion video, HDTV, automated insertion, billing and advertising administration.
- **A New Income Opportunity.** Any local retail or classified print advertiser is a prospective AdView advertiser. AdView offers the impact of full color television with lower production cost than print — a combination advertisers find hard to resist. The opportunities are practically limitless!

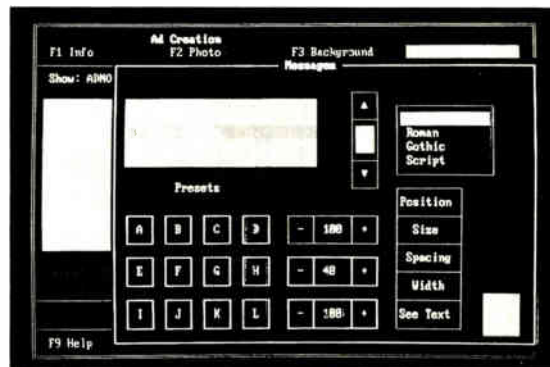

AdView uses a proven 'point-and-click' graphic interface that's so easy anyone can learn it in minutes!

**ARVIS™** The Right Spot At The Right Time

# BANDWIDTH CONSERVATION

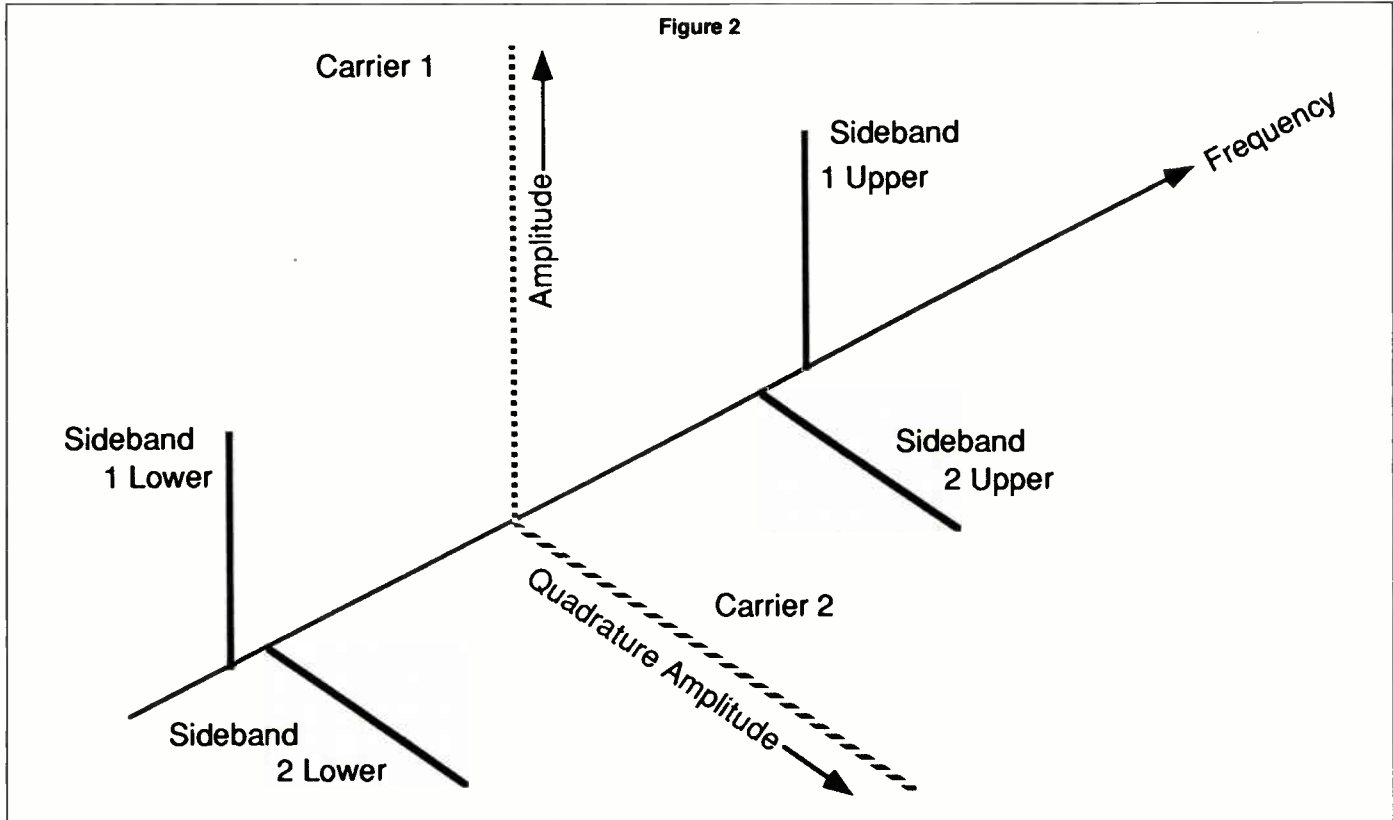

to only -15.2 dB. The undesired result is crosstalk, with a desired to undesired signal ratio of only 15.1 dB. (For a 1.0 degree phase error, the separation is still only 35.2 dB.)

### S/N detection gain

These difficulties have bought us a 6 dB reduction in the required transmitted peak power for the same sideband levels and a 3 dB signal-to-noise detection gain when compared with envelope detection.

This 3 dB signal-to-noise detection gain for DSBSC can be visualized in two ways. In envelope detection, only the amplitude of the signal is used, but in synchronous detection, both the

amplitude and *phase* are used. Because half the random noise will be in phase with the desired signal and half will be in phase quadrature (+90 degrees), only half the noise will be demodulated. This follows from our earlier discussion of the loss of the demodulated signal as the reinserted carrier's phase error approaches 90 degrees.

Another way to look at the detection gain is that envelope detection uses only one sideband, but synchronous detection uses both sidebands. The sidebands add in-phase (if the carrier's phase error is 90 degrees, they are out of phase and cancel) or on a 6 dB voltage basis, while the random noise associated with each sideband adds on a 3 dB power basis.

Now, with a discussion of DSBSC behind us, how can we combine two DSBSC signals in the same spectrum space? The answer is in our several mentions of a 90 degree carrier phase error not allowing the recovery of *any* of the modulating signal. If we use two different modulating signals to modulate two carriers of identical frequency and amplitude but differing in phase by 90 degrees—i.e., in phase quadrature—reinserting one of those carriers will demodulate the one signal but not the other, and visa versa.

Figure 2 is a frequency domain graphic representation of this. The carriers, because they are not transmitted, are shown as dashed lines. (Actually, some carrier is usually retained

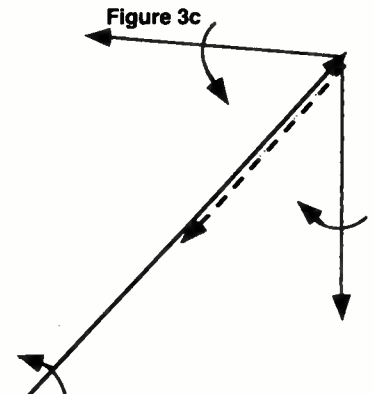
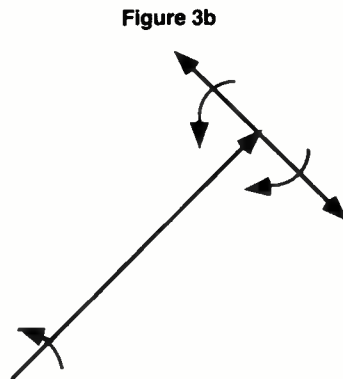
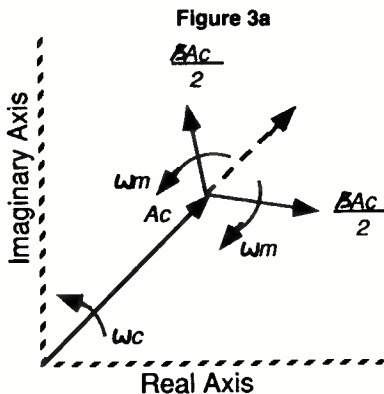



# LEAKAGE DETECTION

# PLUS

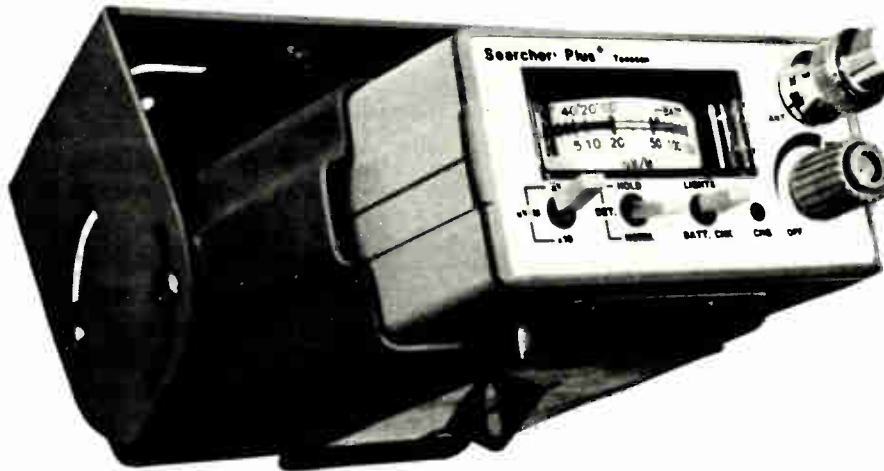

## Searcher Plus<sup>+</sup>

### LEAKAGE DETECTION PLUS CLI MEASUREMENT

- + Meter calibrated in microvolts per meter
- + Truck mounted and handheld operation
- + Midband channel receiver needs no special carrier

Searcher Plus<sup>+</sup> offers features to speed identification and repair of signal leaks. It fills the need for an affordable, calibrated truck mounted receiver for your leakage control program, with the added versatility of hand held operation.

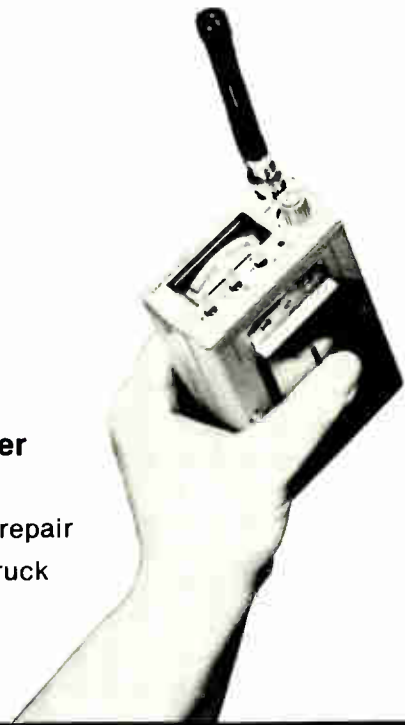

**CALL TO ORDER YOURS TODAY....**



TRILITHIC

**Texscan**  
INSTRUMENTS

3169 N. Shadeland Avenue Indianapolis, IN 46226  
PHONE: (317) 545-4196 1-800-344-2412  
FAX: 317-547-2496 TELEX: 244-334 (RCA)

Figure 4a

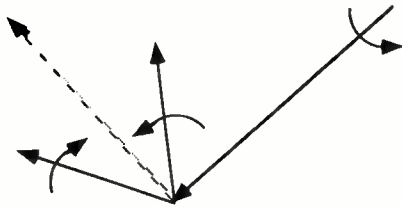

Figure 4b

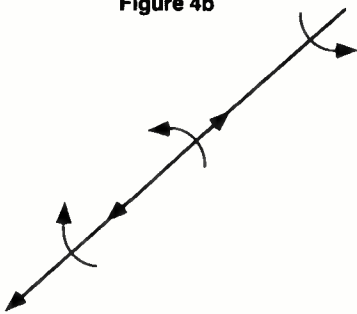
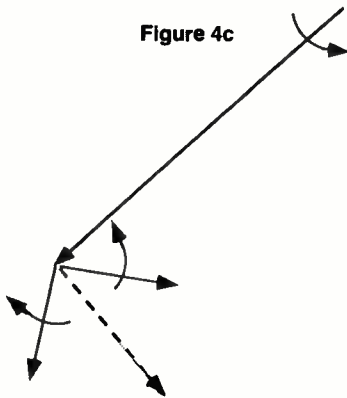

Figure 4c



second =  $360 f_c$  degrees per second). Its projection on the real axis will be the transmitted waveform. The carrier is represented by the longer phasor extending from the origin of the coordinates, and the two smaller phasors at its tip represent the two sidebands.

**Amplitude or angle modulation?**

If the two sideband phasors' resultant (shown in Figures 3a, b, and c as a dotted phasor) changes the length of the carrier's phasor, they have changed its amplitude and represent *amplitude* modulation. If their resultant is perpendicular to the carrier's phasor, as in Figures 4a, b, and c, they are not affecting its amplitude but are changing its rotational position and velocity; this is *angle* (frequency and phase) modulation.

For the amplitude modulation example in Figure 3, the modulation phasors, rotating in opposite directions, will alternately increase the carrier's amplitude (3a), not affect the carrier's amplitude (3b), and decrease the carrier's amplitude (3c). But, their angle or phase effects always cancel out.

Figure 4 shows angle modulation of a carrier by a single sinusoid (with just two sidebands shown for this narrow band example). In Figure 4a the two sidebands are advancing the phase of the carrier, in 4b they are not affecting it, and in 4c they are retarding it. In each case, their amplitude effects cancel out.

We can use a phasor diagram to visualize just what happens when we try to demodulate sidebands with a carrier that is in phase quadrature with the carrier that was used to create these amplitude modulation sidebands. In

Figure 5, the carrier represented by the solid line is being amplitude modulated. But notice that if we try to demodulate these same two sideband phasors with a carrier 90 degrees different in phase, the sidebands now represent angle modulation and have no amplitude component to be demodulated. (Actually, there is amplitude modulation at the carrier's second harmonic, but this is easily removed by filtering).

By modulating two signals onto two identical carriers in phase quadrature and then removing those carriers, we have reduced the peak transmitted power requirement, improved the S/N ratio, and put two signals in the space formerly used by one—at the cost of increased demodulation complexity. ■

Figure 5

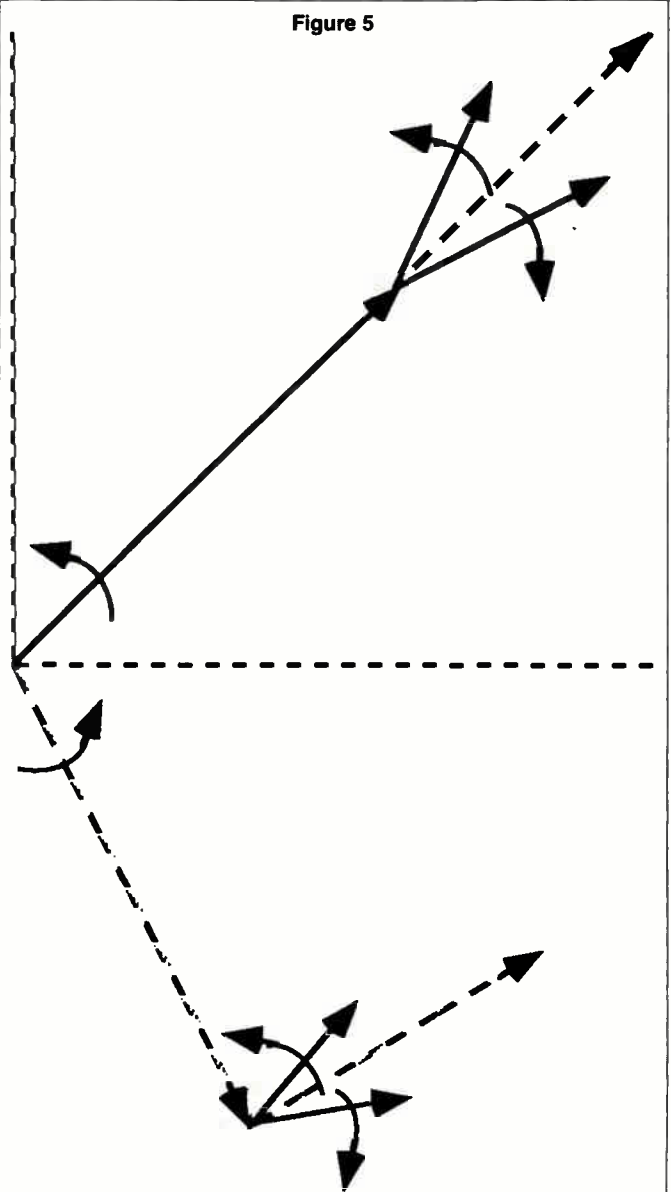

to aid in carrier regeneration. In the Zenith Spectrum Compatible HDTV System, the carrier is suppressed by 30 dB). The signal modulating carrier 2 in this example is at a lower frequency than the signal modulating carrier 1, causing the upper and lower sidebands of carrier 2 to be closer together than those for carrier 1.

Figure 3a is a phasor representation of a carrier amplitude modulated by a single sinusoid. This is the same condition as in Figure 1 but now shown as phasor (an electrical vector) rotating counterclockwise in the complex plane at a speed  $\omega_c$  ( $\omega_c = 2\pi f_c$  radians per



# EAGLE'S OUTDOOR ADDRESSABLE TRAP SYSTEM AN ALTERNATIVE TO SET TOP DESCRAMBLERS FINALLY: CONSUMER FRIENDLINESS WITH IMPULSE PPV

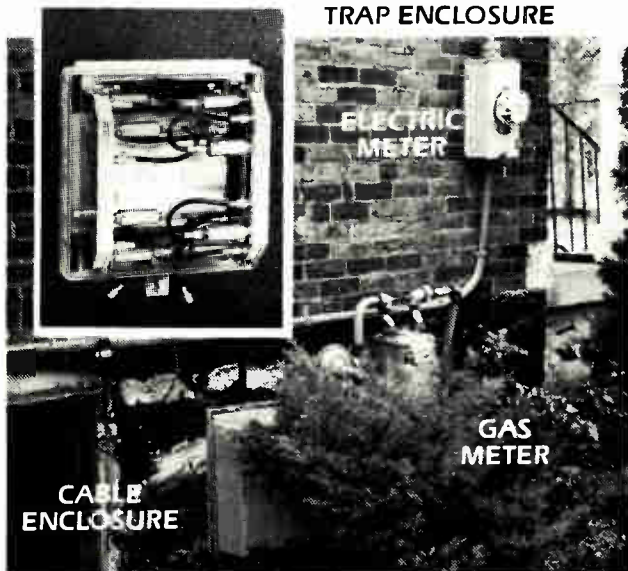

## TYPICAL INSTALLATION

**Addressable Trap System** eliminates many of the consumer unfriendly characteristics of present day converter descramblers. **Eagle's Addressable Trap System** provides:

- (A) Ability to record a premium channel while watching a different premium channel.
- (B) A converter descrambler is not required for each TV.
- (C) TV and VCR remote controls can be used.
- (D) Cable ready sets can use their extra channel capacity possibly eliminating a converter.
- (E) Picture and sound distortions are minimized.
- (F) Switch boxes or complicated wirings are not required.

A trapped system is very friendly since all subscribed to channels are present at each TV set simultaneously in an unscrambled mode. Only undesired channels are removed. When addressability and Impulse pay-per-view are added, as with **Eagle's Addressable Trap System**, consumer friendliness, versatility, and economy for today's system operator are the result. The control box in which the traps are located is outside the home similar to electric, gas or water meters, eliminating the need for customer change of service or repair scheduling.

One hundred million traps used in cable systems testify to their reliability, simplicity, and economics for controlling premium channels. Adding **Addressability** and **IPPV** to basic traps, will extend their use many years into the future.



OPTIONAL REMOTE UNIT

## FEATURES

- 4 or 8 tiers of negative, positive or multichannel addressable filters; 256 combinations selectable.
- Consumer friendly with VCRs, cable ready sets, and remote controlled TVs.
- Controls signal delivery to multiple TV sets from one trap switch enclosure.
- Uses your present negative or positive traps.
- Powered from the home; cable system powering changes not required.
- All service disconnect capability; over 80 dB isolation.
- Non-volatile memory protects data during power outages.
- Automatic scheduling of events & previews.
- No need to enter home for audits.
- Automatic shut-down after time out.
- IBM PC or compatible computer control.
- Billing program; compatible with billing systems.
- Transparent to other scrambling technology.
- Compatible with non-attended remote headends.
- Ground block.
- Non-interrupted test points.

## OPTIONAL REMOTE UNITS

- Subscribe to premium programming without need to call the cable system; order IPPV by event number.
- Auto-dialer transmits customer usage back to the system operator, using store and forward techniques.
- Pre-authorize customers for limited amounts of pre-paid programming.
- Parental Control of premiums or all service.

# EAGLE

COMTRONICS INC.

MADE  
IN  
U.S.A.

# Rebuilding in today's complex environment

**T**oday's system rebuild faces more complex issues than at any time in the short history of cable television. The immediate problem is to build a new system within the confines of an existing system. This must be accomplished with minimal impact on the existing subscriber base.

The rebuilt system must continue to supply current services with improved picture quality. It must justify rebuild expenses. And, it must supply new revenue sources.

Some examples of new revenue sources available via a rebuild are:

**Impulse ordering.** Should the system install technology which permits subscribers to purchase pay-per-view and other events at the push of a button? If so, what services should be acquired to take advantage of this technology?

**Digital audio.** Should the system offer a new premium service of compact disc quality audio? Should it allocate bandwidth for this purpose?

**Additional pay services.** The addition of new channels, and, probably new technology makes room for additional new pay services. What services should the system offer to attract the most subscribers and add to system revenues?

**Additional basic channels.** What new basic services will subscribers want when channel capacity expands?

**Enhanced pay service security.** Addressable technology increases signal security for a rebuilt system. More secure services mean less system theft, enhancing the revenue stream from basic and pay services.

The primary reasons for a rebuild are franchise renewal and investment protection. Franchise renewal

is easy to understand. It means that the communities in which the system is located want more services. Franchise protection is simply relief from the threat of an overbuild or other outside competition.

The rebuilding system must make several decisions relating to technical issues.

There must be an immediate consideration of what customer interruptions there will be and their duration. Understanding the impact of a rebuild on customers is a top priority.

Proposed system bandwidth is another high priority item. How many channels are needed in the design?

reliability, and long-term operating costs. System reliability considerations include soft redundancy, the use of standby powering and status monitoring. Long-term operating costs encompass power and after-warranty repairs.

Finally, the rebuilding system must consider its employees. It must train them in the operation of the newly upgraded system and must retain their services.

### Three rebuild methods

After determining all these factors, it is time to start on the rebuild. There are three available methods of rebuilding.

The first option is to build a new system coincident with the existing plant. The rebuild is done sectionally and subscribers shift over to the new plant with minimal impact on service. Subscribers receive new converters and new programming services and equipment features.

This technique is, by far, the easiest for the system engineer and the subscriber. It also has the highest capital investment: all new plant, electronics and converters. It offers the highest potential revenue return via new services, subscriber features and through the acquisition of new subscribers.

The second option is an upgrade. This technique requires some minimal system interruption. The installation of higher technology electronics into existing housings allows for higher bandwidths and more channels. The downside is that 20 percent to 25 percent of the cable in most systems is poorly maintained

and must be replaced. There will be some changeout of connectors and relocation of line extenders, causing significant service interruptions. Handling these interruptions requires more than technical expertise. System marketing personnel must use all available



Should HDTV be considered? Should the system use a one-way phone return for impulse orders or is a two-way plant more desirable?

System specifications for a rebuild include carrier-to-noise, carrier-to-beat, short-term capital cost, system

*By Jon Ridley, Senior Applications Engineer, Jerrold Distribution Systems Division, General Instrument Corporation*



## REBUILDS

media to explain the interruptions and the advantages to come from the work.

The upgrade technique is capital cost-effective in that it limits capital expenditure exposure to electronics, requires only small amounts of cable and reduces labor costs.

### The strategic upgrade

The third rebuild option is the strategic upgrade. This requires an in-depth overview of the system, defining existing weaknesses and strengths. The engineer would redesign the system to reduce cascades, increase hub sites and extend bandwidth. There would be a significant increase in picture quality, channel capacity and, concurrently, a reduction in service complaints.

The strategic upgrade would use, to the system's advantage, enhanced technology, fiber optics and trunk rerouting as well as possible hub sites.

The rebuild also faces the reality of increased system specifications. The system must plan for an undefined C/N required for HDTV, higher tap levels (multiple sets, VCRs and FM), and greater reliability (reduced services calls, lower plant operating lists). Strict attention must be paid to fixed operating costs (power). The rebuilding system also must consider revenue security (more secure traps and converters).

Today's typical system attempts to achieve picture quality equivalent to urban off-air reception. To do this with today's equipment means cascades limited to 16 to 20 amplifiers. These, too, will be further reduced with the introduction of HDTV.

### Rebuild variables

The method selected for rebuilding a system is dependant on some well defined variables.

1: Age of plant. How old is the existing equipment? How much can the system save? How much value can it depreciate?

2: Quality of prior preventive maintenance. How well has the system maintained its current equipment? How much can it use in a newly rebuilt system? How much must be discarded?

3: A realistic assessment of needs and resources. Before embarking on a rebuild, a system must realistically determine the final objectives and goals. Also to be considered is how long the system will operate in its upgraded fashion. The system should, before starting a rebuild, consider future

technologies and their impact.

4: The geography of the system. This will impact directly on labor costs and the type of equipment needed in the rebuild.

5: The impact of competition. Is it possible to rebuild in incremental stages or take a quantum leap to state-of-the-art technology? What are systems in neighboring communities doing? What do subscribers and municipal officials expect from the system?

As more and more franchises come up for renewal, the topic of rebuild becomes increasingly prevalent throughout the industry. Today's cable system, when rebuilding, must pass through a variety of decisions before it powers up the first amplifier.

Hopefully, by following the steps and suggestions outlined here, a rebuild will be less painful for everyone—system personnel, subscribers and local officials. ■

# \$25,000\*

## FACTORY DIRECT PRICING DELIVERS!

Telsta's "Sweet Deal" Package can put a new 1989 A-28 van-mounted Telsta on the road for you with no hassle or headaches and at the lowest factory direct prices.

You'll get the most wanted lift in the CATV industry—fully equipped and ready-to-go.

You'll get fast delivery because we have chassis in stock at five locations across the country.

You'll get the strongest warranty in the industry backed by the strength of Telsta's nationwide network of parts centers and fleet of mobile service technicians.

And you'll get your Telsta direct from the factory with no third-party markup, no dealers, no aggravation. Pick up the phone and call our toll free direct sales line now. Then relax because it's that easy.

**CALL TOLL-FREE: 1-800-521-5351**



Utility version also available. Call for your special price.



# TELSTA®

**A LIFT ABOVE THE REST**

General Cable Company

P.O. Box 666, 5600 West 88th Ave.  
Westminster, Colorado 80030

Phone: 303/427-3700

Facilities in Hayward, CA; Frederick, MD; Lithonia, GA; Muncie, IN

**A Unit of Penn Central Industries**

\* Prices slightly higher in California. Prices good for 1989 chassis only. All prices FOB Telsta plant excluding taxes and registration.

Reader Service Number 76



**BUSINESS CARDS**

# Rebuild Business Directory



**Aerial/Underground  
Construction**

**CABLE SERVICES COMPANY/INC.**

2113 MARYDALE AVENUE  
WILLIAMSPORT, PA 17701

(800) 233-8452  
PA-(800) 332-8545

Reader Service Number 84

**Kennedy Cable Construction, Inc.**  
Communications  
and  
CATV Services

**Frank Walker**  
Marketing Manager

**Kennedy Cable Construction, Inc.**  
Highway 280 West • Post Office Box 760  
Reidsville, Georgia 30453  
(912) 557-4751 • FAX: (912) 557-6545

Reader Service Number 85

**Schenck**  
construction

(206) 867-9694

**Edward A. Schenck**  
President

**Bud Longnecker**      **Imei L. Wheat, Jr.**  
VP/Aerial                      VP/Underground

15042 NE 95th      P.O. Box 3159  
Redmond, WA 98073-3159

**Aerial and Underground Cable TV Construction; Turnkey**

Reader Service Number 86

**RTK**  
**CORPORATION**  
7 Glenwood Avenue, East Orange, NJ 07017  
(201) 678-2083  
Fax #201 678-6971

**JAMES MacGEORGE**  
Vice President

Reader Service Number 87

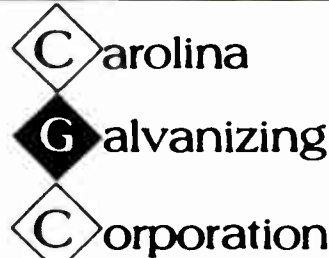

Manufacturer of copper bonded ground rods, galvanized ground rods and accessories, galvanized forged eye anchor rods and no wrench screw anchors.

**MICKEY WILSON**  
National Sales Manager  
Utility Products Division

P.O. Box 487  
Aberdeen, NC 28315  
Phone (919) 944-2171  
Outside NC (800) 476-2156

Reader Service Number 88

**YOU DESERVE QUALITY CAD SERVICE!**

- STRAND MAPPING
- SYSTEM DESIGN
- DRAFTING SERVICES
- AS-BUILT MAPPING
- WALKOUT
- MAKE READY

**CABLE LINK, INC.**  
**CHRIS CHAMBERS**  
CAD PRODUCT MANAGER

280 COZZINS STREET      (614) 221-3131  
COLUMBUS, OHIO 43215-2353      FAX (614) 222-0581

Reader Service Number 89

**ELAN**  
ENGINEERING

31275 Northwestern Hwy.  
Suite 228  
Farmington Hills, Mi 48018  
(313) 855-6575

**Turnkey Construction**  
**CATV, LAN and Fiber Optic Systems**

**Michael W. Refalo**

Reader Service Number 90

**Harold Bigham**  
President

**Cable Construction, Inc.**  
Complete CATV Construction

(904) 932-6869      P.O. Box 903  
Gulf Breeze, FL 32561

Reader Service Number 91

## WHO'S ON THE COVER

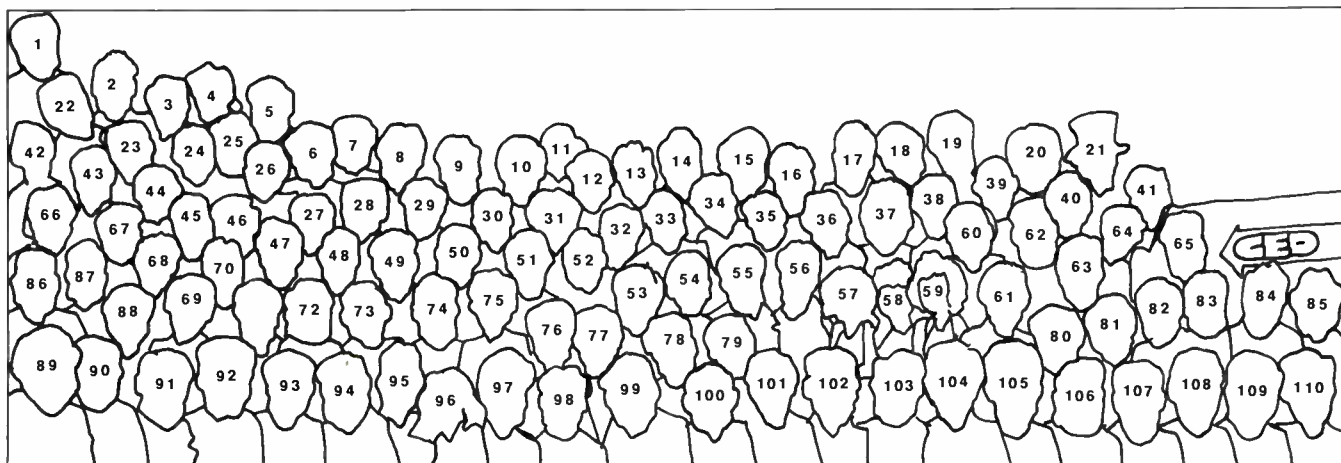

- |                        |                        |                          |
|------------------------|------------------------|--------------------------|
| 1. John Gutierrez      | 38. Lou Corvo          | 75. Jim Farmer           |
| 2. Keith Rauch         | 39. Joe Hesler         | 76. Shellie Rosser       |
| 3. Randall Carver      | 40. Donald McClatchie  | 77. Steve Raimondi       |
| 4. Ron Speckman        | 41. Mike Drum          | 78. Ron McMillan         |
| 5. Don Rice            | 42. Clayton Dore       | 79. Paul Resch           |
| 6. E. Charles Hanchett | 43. R.A. Hatfield      | 80. Nick Hamilton-Piercy |
| 7. Tim Graham          | 44. David Lantz        | 81. Larry Nelson         |
| 8. Tom Osterman        | 45. Eric Loytty        | 82. Mike Jeffers         |
| 9. Doyle Haywood       | 46. John Roskowski     | 83. Par Peterson         |
| 10. Martin de Alminana | 47. Ed Burke           | 84. Brian James          |
| 11. Lee Thompson       | 48. Richard Lundy      | 85. Geoff Heathcote      |
| 12. Chris Huffman      | 49. Bob Scott          | 86. John Dawson          |
| 13. Dieter Brauer      | 50. Tony Wechselberger | 87. Joe Helms            |
| 14. Syd Fluck          | 51. Ted Dudziak        | 88. Joe Van Loan         |
| 15. Marshall Borchert  | 52. Joe Glaab          | 89. Wendell Bailey       |
| 16. Fred Wilkenloh     | 53. Fred Kaiser        | 90. Vito Brugliera       |
| 17. John Lockwood      | 54. John Unverzagt     | 91. Dick Hickman         |
| 18. Roger Kennedy      | 55. Randy Karr         | 92. David Large          |
| 19. Fred Rogers        | 56. Scott Lumley       | 93. Nick Worth           |
| 20. Donald Runzo       | 57. Judy Medley        | 94. Bernie Lechner       |
| 21. Bill Killion       | 58. Cathy Wilson       | 95. Matt Miller          |
| 22. Gary Drescher      | 59. Kathy Berlin       | 96. Katherine Rutkowski  |
| 23. Randy Oster        | 60. Matt Leschinger    | 97. Walt Ciciora         |
| 24. Hal Bjorklund      | 61. Roger Brown        | 98. Alex Best            |
| 25. David Morris       | 62. Chuck Merk         | 99. Frank Ragone         |
| 26. Abram Ackerman     | 63. Steve Windle       | 100. Dick Shimp          |
| 27. Elias Livaditis    | 64. Dick Grasso        | 101. Gary Stanton        |
| 28. Bill Robertson     | 65. Rob Stuehrk        | 102. Abe Sonnenschein    |
| 29. Mircho Davidov     | 66. Norman Gillaspie   | 103. Mark Bowers         |
| 30. Chris Sophinos     | 67. Harold Zoberg      | 104. Mike Aloisi         |
| 31. Bill Dancy         | 68. John Kaye          | 105. Chris Bowick        |
| 32. Dario Santana      | 69. Bob Luff           | 106. Hank Cicconi        |
| 33. Frank Topping      | 70. Ned Zibro          | 107. Bob Dickinson       |
| 34. Sherwood Hawley    | 71. Paul Heimbach      | 108. James Grabenstein   |
| 35. Jerry Laufer       | 72. Jim Chiddix        | 109. Ted Hartson         |
| 36. Chuck Krone        | 73. Roy Ehman          | 110. Bert Henscheid      |
| 37. Marty Ingram       | 74. Tom Elliot         |                          |

## TECHNICAL SESSIONS

Not surprisingly, HDTV and fiber optics will once again be featured in this year's NCTA Show technical session schedule. But other important subjects, like signal leakage, audio, addressability and pay-per-view will be discussed during the 10 sessions. What follows is a list of sessions and speakers, accurate up to press time. All sessions will be held in rooms A and B of the West Ballroom in the Dallas Convention Center. Those rooms are located on the Exhibit Hall level.

### Monday, May 22

*Cable Labs—a review of Cable Lab's Technical Advisory Committee subcommittee efforts*

2 p.m. to 3:30 p.m., Room A

**Moderator:** Walter S. Ciciora, Ph.D., vice president, engineering and technology, American Television and Communications (ATC).

**Speakers:** James Chiddix, senior vice president, engineering and technology, ATC, "Fiber Optic Issues;" Tom Elliot, director of R&D, Tele-Communications Inc., "Operations Issues;" Nick Hamilton-Piercy, vice president, engineering and technical services, Rogers Cablesystems, "Advanced Television System Testing;" Tom Jokerst, director of engineering, Continental Cablevision of St. Louis County, "A Review of the Cable Labs Consumer Electronics Interface Subcommittee;" Ed Callahan, vice president R&D, United Cable Television, "Technologies for New Businesses."

*HDTV Transmission Implications*

2 p.m. to 3:30 p.m., Room B

**Moderator:** Wendell Bailey, vice president science and technology, NCTA.

**Speakers:** Gerald Robinson, principal engineer, Scientific-Atlanta, "Selected Topics on HDTV: A Tutorial on the Basics;" Joseph Waltrich, senior project engineer, Jerrold Applied Media Lab, "The Pros and Cons of Maintaining NTSC Compatibility for Advanced TV;" Ron Horchler, director equipment engineering, Warner Cable, "Relative Cost Implications for Implementing ATV Proponent Systems in a CATV System;" Carl Eilers, manager electronic systems R&D, Zenith Electronics Corp., "Simulcasting with the Spectrum Compatible ATV System."

*Addressable and PPV Technologies—Special Deliveries*

4 p.m. to 5:30 p.m., Room A

**Moderator:** Ed Callahan, vice president R&D, United Cable Television.

**Speakers:** Richard Merrell, manager decoder logic design, Zenith Electronics Corp., "An Auto-dialer Approach to Pay-Per-View Purchasing;" Lamar West, senior staff engineer, Scientific-Atlanta, "Off-Premises Technology Comparisons;" Marc Kauffman, manager, Jerrold Applied Media Lab, "Timing Considerations in RF Two-way Data Collection and Polling;" James Chiddix, senior vice president engineering and technology, ATC, "Off-premises Addressability: A CATV Industry Challenge;" Didier Flaender, executive director, TDF Lorraine Research Center, "A Digital Coding System for Video Signal to Distribute Video Monitoring Images on Coaxial Networks."

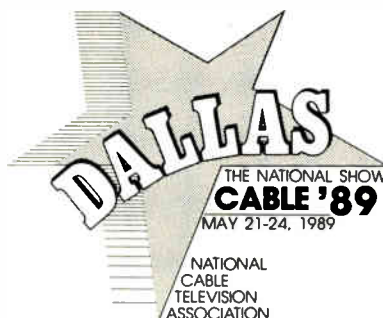

*Operational Improvements in Existing Cable Systems*

4 p.m. to 5:30 p.m., Room B

**Moderator:** Michael Jeffers, former vice president engineering, Jerrold.

**Speakers:** Blair Schodowski, senior engineer, Scientific-Atlanta, "Improved Method for Video Inversion Scrambling Systems;" Patrick McDonough, corporate chief engineer, United Cable Television, "The Technical Performance Review: What Needs to be Done?;" Reed Burkhart, supervisor, Galaxy Systems Engineering, Hughes Communications Galaxy, "Cable Headend Polarization Alignment Concerns During Peak Sunspot Cycle;" Martin Cowen, electrical engineer, Scientific-Atlanta, "Advanced System Upgrade Requirements and Design."

### Tuesday, May 23

*Audio—Alive and Well and Getting Better!*

7:30 a.m. to 9 a.m., Room A

**Moderator:** Frank Ragone, vice president engineering, Comcast Cable.

**Speakers:** Ned Mountain, vice president marketing, Wegener Communications, "Audio 101—Television Audio—A Systems Issue for Cable;" Joseph Stern, president, Stern Telecommunications, "A Flexible Spectrum Efficient Transmission System for Cable Audio;" James Green, manager application engineering, Jerrold Applied Media Lab, "Delivering Digital Audio;" Alex Best, senior vice president, engineering, Cox Cable, "BTSC Stereo Operating Practices."

*Fiber Optic Architectures*

7:30 a.m. to 9 a.m., Room B

**Moderator:** David Large, director video product planning, Raynet.

**Speakers:** Nick Hamilton-Piercy, VP engineering and technical services, Rogers Cablesystems, "Rogers Fiber Architecture;" John Mattson, business development manager for fiber optics, Scientific-Atlanta, "A Fiber Optic Design Study;" John Fox, Ph.D., British Telecom Research Labs, "Evolution of the British Telecom Switched-Star Cable TV System;" Lemuel Tarshis, Ph.D., VP and General Manager, distribution systems, Jerrold, "An Economic Assessment of Fiber Optic Applications;" David Robinson, director fiber optic programs, Jerrold Applied Media Labs, "Switched Star Fiber Optic Architectures for Cable TV."

*System Powering*

9:30 a.m. to 11 a.m., Room A

**Moderator:** Bert Henscheid, vice president research and development, Texscan.

**Speakers:** Larry Lindner, product manager, Alpha Technologies, "Establishment of Battery Standards for CATV Standby Powering;" Jeffrey Cox, manager of engineering, control systems, Magnavox CATV, "Data Collection for Status Monitoring Systems;" Peter Deierlein, senior engineer, Magnavox CATV, "CATV System Powering Considerations;" Tom Osterman, engineering supervisor, Alpha Technologies, "New Approaches to CATV System Powering."

*HDTV Testing*

9:30 a.m. to 11 a.m., Room B

**Moderator:** Ted Hartson, vice president and chief engineer, Post-Newsweek Cable.

**Speakers:** Rene Voyer, senior research engineer, Communications Research Centre, Canadian Department of Com-



## TECHNICAL SESSIONS

munications, "HDTV Cable Tests: Method of Measurement;" Dave Wachob, director advanced technologies, Jerrold Applied Media Lab, "Design Considerations for an Advanced TV Test Facility;" Tim Homiller, engineering manager, Jerrold Applied Media Lab, "Noise Measurements for a CATV System—C/N, S/N, Phase Noise;" Dan Pike, vice president of engineering, Prime Cable, "The Effects of Reflections;" Brownen Jones, contractor to the Advanced Television Test Center and Cable Labs, "HDTV Picture Quality Tests: Methods of Measurement;" (an update from the CCIR Extraordinary Meeting in Geneva).

Wednesday, May 24

### Measuring Cable System Signal Leakage

9 a.m. to 10:30 a.m., Room A

**Moderator:** Robert Dickinson, president, Dovetail Systems Corp.

**Speakers:** Ted Dudziak, project engineering manager, Wavetek RF Products, "Antenna Considerations for Controlling Cable System Leakage;" Chris Duros, general manager, CableTrac Inc., "Interpretations of Airborne Leakage Data;" Steven Biro, president, Biro Engineering, "Advances in CLI Flyover Measurements, the Helicopter Approach;" Bob Saunders, director of engineering, Sammons Communications, "CLI Measurements for Large Systems."

### Recent Developments in AM Fiber

9 a.m. to 10:30 a.m., Room B

**Moderator:** Joseph Van Loan, independent consultant.

**Speakers:** Rezin Pidgeon, principal engineer, Scientific-Atlanta, "Performance of AM Multi-channel Fiber Optic Links;" David Grubb III, manager analog programs, Jerrold Applied Media Lab, "AM Fiber Optic Trunks—A Noise and Distortion Analysis;" Carl McGrath, supervisor, CATV Lightwave Group, AT&T Bell Laboratories, "Multi-channel AM Fiber Optic CATV Trunks—From Lab to Reality;" Ernest Kim, manager of electro-optic technology, TACAN Corp., "Method for Including CTBR, CSO and Channel Addition Coefficient in Multichannel AM Fiber Optic System Models;" David Pangrac, director of engineering, ATC, "Fiber Backbone: Multi-channel AM Video Trunking."

# NEW, HIGH OUTPUT, LOW COST CATV Heterodyne Headend Systems From BLONDER-TONGUE

## Performance Specs Comparable To Headend Systems Costing Up To 3 Times As Much!

### NEW Heterodyne Processor - ESHP #5984

+60 dBmV output level. BTSC stereo and color compatible. Optional automatic back-up for switching to internal standby carrier or external composite IF on loss of input signal.

### IMPROVED, REDUCED COST Modulator - ESHM-C #5928

+60 dBmV output level. Dual +40 dBmV IF loop thru is standard. Convenient slide-in channel drawer. Money saving drawer exchange policy when changing channels.

### LOWER COST Modulator - SAVM-60 #5944

+60 dBmV output level. Single IF loop-thru is standard. Replaceable heterodyne channel converter board.

### FREQUENCY AGILE Modulator FAVM-450-60 #5965

+60 dBmV output level. Rear panel DIP switch for easy channel changes. Provides output for any TV channel up to 450MHz including HRC, IRC, inverted.

### DUAL BAND Satellite Receiver - CESR #6150

Operates on C and Ku band. Pre-set 6.8 MHz or tuneable audio subcarrier. Videocipher\* and B-MAC compatible.

### HIGH ISOLATION 8 and 12 Way Combiners - OC-8 #5951 and OC-12 #5953

Low net combining loss.

### NOISE FILTERING 12 Way Frequency Selective Combiner - OC-12F #5953

Reduces noise, spurious response and intermod products in any headend. High isolation. Five groups of 12 adjacent channels cover channels 2-61.

### NEW TWO YEAR WARRANTY ON ALL PRODUCTS

The ESHP and ESHM-c meet the present need for a high output, low cost headend that *doesn't need to be derated* when it comes to real world adjacent channel operation.

Pre-fabricated headends are shipped complete to save you time and money. Each system is built to your specs using totally compatible components . . . burned-in and fully tested . . . or purchase individual components and assemble your own headend.

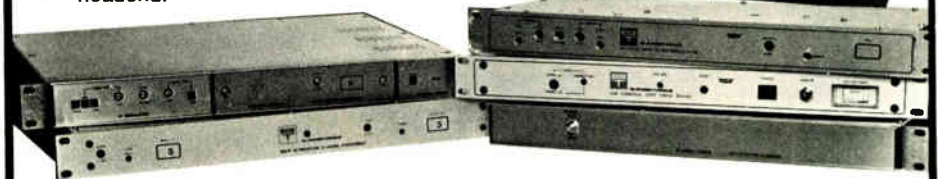

For additional headend information or system design assistance, call us at 201-679-4000.



## BLONDER-TONGUE

LABORATORIES INCORPORATED

ONE JAKE BROWN ROAD, OLD BRIDGE, N.J. 08857

\*Videocipher is a trademark of General Instrument Corp.

Fax No. 201-679-4353

Reader Service Number 77

Communications Engineering and Design May 1989 117

## ADDRESSABILITY CALLBOOK

The following companies have paid a fee to have their listing appear in the Addressability Callbook.

## ANIXTER COMMUNICATIONS®

**Anixter Cable TV . . . (312) 677-2600**  
**WATS(National) . . . (800) 323-8166**

4711 Golf Road

One Concourse Plaza

Skokie, IL 60076

PERSONNEL: John Egan, President and CEO; Gordon Halverson, Executive Vice President; Marty Ingram, VP/ Product Management & Mktg.; Dean DeBaise, VP/New Business Development

REGIONAL OFFICES: Anaheim: 4905

E. Hunter Ave., Anaheim, CA 92807,

(714) 779-0500, FAX (714) 777-1527;

Atlanta: 550 Old Peach Tree Rd.,

Suwanee, GA 30174, (404) 995-5110,

FAX (404) 963-5342; Chicago: 888

Thomas Dr., Bensenville, IL 60106,

(312) 350-7788, FAX (312) 350-7840;

Cleveland: 8060 Snowville Road,

Brecksville, OH 44141 (216) 526-0919;

Dallas: 1620 Crosby Road, Suite 115,

Carrollton, TX 75006, (214) 446-7337,

FAX (214) 242-6079; Denver: 8101 E.

Prentice, Ste. 210, Englewood, CO

80111, (303) 740-8949; Houston: 4799

Eastpark Drive, Houston, TX 77028-

5997 (713) 674-1111; Iron Mountain:

1023 River Ave., Iron Mountain, MI

49801, (906) 774-4111, FAX (906) 774-

6287; Long Island: 7 Michael Ave.,

East Farmingdale, NY 11735, (516)

293-7788, FAX; (516) 293-7503;

Orlando: 2901 Titan Row, Suite 124,

Orlando, FL 32809 (407) 240-1888;

Seattle: 18435 Olympic Ave. South,

Seattle, WA 98188, (206) 251-6760,

FAX (206) 251-0846; Wharton: 321

Richard Mine Rd., Wharton, NJ 07885,

(201) 328-0980, FAX (201) 328-1267.

DESCRIPTION: Anixter Cable TV is a supply specialist to the CATV industry. A complete line of cable television products is offered, including fiber optic cable, connectors, electronics and apparatus, satellite receiving equipment, headend equipment, subscriber devices, distribution electronics, coaxial cable and connectors, aerial and underground construction material, system passives, drop and installation material, tools and safety equipment, and test equipment.



**Cable Link, Inc. . . . (614) 221-3131**  
**FAX . . . . . (614) 222-0581**

280 Cozzins St.

Columbus, OH 43215

PERSONNEL: E. Jack Davis, President;

Bill Holehouse, Vice President of Sales;

'Zack' Zekri, Sr. Account Executive;

Stan Smith, Sr. Account Executive;

Pete Tippetan, Sr. Account Executive

REGIONAL OFFICES: Lucy Espinoza,

8610 Broadway St., Suite 210, San

Antonio, TX 78217 (512) 822-1303/

1350

DESCRIPTION: Cable Link Inc. buys, refurbishes and sells CATV equipment.

Our products include addressable, non-

addressable converters, linegear,

headend, traps, passives, parts, and

hardware. We also repair Oak and

Jerrold addressable converters. Also

CAD Map Design, Character Generator

Services.



Cable Services Company Inc.

**Cable Services . . . (717) 323-8518**  
**Company, Inc.**

**WATS(National) . . . (800) 233-8452**

**WATS(State) . . . . . (800) 332-8545**

**FAX . . . . . (717) 322-5373**

2113 Marydale Avenue

Williamsport, PA 17701-1498

PERSONNEL: John B. Roskowski,

President; George Ferguson, Vice

President; John M. Roskowski, Vice

President Construction; Harry A. Wahl,

Vice President-Turnkey Sales; Robert

Brantlinger, Director/Marketing

DESCRIPTION: Complete fiber optic,

coax, or LAN, turnkey construction

and supply company. Services include

aerial and underground construction,

splicing, house drop installation and

headend installation. Also supplier of

all major manufacturers and in house

design, repair and engineering facilities.

## Cable Technologies International, Inc.

**Cable Technologies .(215) 953-0100**  
**International, Inc.**

**FAX . . . . . (215) 322-6127**

1051 County Line Road

Suite 107

Huntingdon Valley, PA 19006

PERSONNEL: Paul E. 'Pete' Morse,

Jr., President; Diane Bachman, Sales;

Carol Ritchie, Account Executive; Terry

Jusits O'Neill, Account Executive

DESCRIPTION: Purchase and Sales of

subscriber products including

converters, video control units, handheld

remote control units - new and

refurbished. Consulting for cable

operators in the use of IPPV,

addressability and other transactional

services, marketing services for cable

operators, computer software

development for addressability.

## JERROLD

**Jerrold . . . . . (215) 674-4800**

**General Instrument**

**WATS(National) . . . (800) 523-6678**

**WATS(State) . . . . . (800) 562-6965**

2200 Byberry Road

Hatboro, PA 19040

PERSONNEL: George Safiol, President

& C.O.O.; Hal Krisbergh, President,

Jerrold Division; Anthony Aukstikalnis,

VP-GM Subscriber Systems Div.;

Lemuel Tarshis, VP-GM Distribution

Systems Div

REGIONAL OFFICES: 767 Fifth Ave.,

45th Floor, New York, NY 10153, (212)

207-6300; 2611 Westgrove Road, Ste.

108, Carrollton, TX 75006, (214) 248-

7931; 7100 E. Belleview Ave., Ste. 101,

Englewood, CO 80111, (303) 740-6118;

556 N. Diamond Bar Boulevard, Ste.106,

Diamond Bar, CA 91765, (714) 860-

3600.

DESCRIPTION: Designer and

manufacturer of full line of electronic

CATV and SMATV equipment.

Distribution systems: conventional,

feedforward, power-doubling and

Quadrapower™ amplifiers, taps and

passives and accessory equipment; fiber

optics electronics. Subscriber systems:



## ADDRESSABILITY CALLBOOK

plain, pay and addressable Jerrold IMPULSE 7000 Series, STARCOM and TOCOM 5503-VIP converters, push-button response systems, addressable controllers and scrambling equipment. Headend systems: MATV and CATV satellite receivers, frequency agile headend modulators and encoders, processors, stereo encoders and scrambling equipment; local area network; broadband distribution equipment; advanced status monitoring and point-to-point broadband modems.

## MIDWEST CATV

A division of Midwest Corporation

**Midwest CATV . . . . .(304) 343-8874**  
**A Division of Midwest Corporation**  
**WATS(National) . . . . .(800) 532-2288**  
**FAX . . . . .(304) 346-0624**

1012 Kanawha Blvd. East

P O Box 271

Charleston, WV 25321

**PERSONNEL:** Jerry Thompson, President; Christopher Sophinos, V.P./Chief Operating Officer; John Johnson, Purchasing Manager

**REGIONAL OFFICES:** Northeast: James McCauley, Vice President, Tri-County Business Campus, 72 Robinson Street, Pottstown, PA 19464, (800) 458-4524; East: Jack Crouse, Vice President, P.O. Box 226, Clarksburg, WV 26301, (800) 532-2288; South: Elijah Midkiff, Vice President, 2697 International Parkway III, Suite 128, Virginia Beach, VA 23452, (800) 643-2288; Southwest: Bill Cody, Sales Manager, 2118 Wall Street, Suite 800, Garland, TX (800) 421-4334; Ocala Distribution Center, Scott Wells, Sales Manager, 5150 West Highway 40, Ocala FL 32675, (800) 433-3765; Central: Bill Whiteley, Vice President, P.O. Box 4519, Lafayette, IN 47903, (800) 428-7596; West: Peter Hineson, Sales Representative, Denver Corp. Tower III, 7900 East Union, Suite 840, Denver, CO 80237, (800) 232-9378.

**DESCRIPTION:** Distributor of a complete line of cable TV equipment: antennas, headend, distribution electronics, passives, taps, connectors, coaxial cable, construction material, towers, drop material, enclosures, pedestals and racks, power supplies, strand, test equipment, tools, traps, safety equipment, fiber optic cable, subscriber descrambling converters, and

all the accessories necessary for the cable operator. Also the Matrix system, an off-premise addressable trap system.



**Pioneer . . . . .(201) 327-6400**  
**Communications of America Inc.**

**WATS(National). . . . .(800) 421-6450**  
 600 E. Crescent Ave.

Upper Saddle River, NJ 07458

**PERSONNEL:** Pete Imamura, President; Jerry Nelson, Director of Sales; David Nicholas, National Sales Manager; Michael Hayashi, Marketing Manager; Fae Kopacka, Northeastern Accounts Manager

**REGIONAL OFFICES:** Gary Campbell, Western Accounts Manager, 507 Black Oak Drive, Chico, CA 95926 (916)

893-4544; Richard Schmeck, Central Accounts Manager, 4600 S. Ulster Street, Metropoint Building, 7th Floor, Denver, CO 80237 (303) 740-6718; Mack Parkhill, Mid-Atlantic Accounts Manager, 2200 Dividend Drive, Columbus, OH 43228 (614) 876-0771;

Jeffrey Gardner, Southeastern Accounts Manager, 3125 Presidential Parkway, Suite 200, Atlanta, GA 30340 (404) 457-1300; John Unverzagt, Director of Engineering, Glenn Sigler, Field Service Manager, 2200 Dividend Drive, Columbus, OH 43228 (614) 876-0771.

**DESCRIPTION:** Pioneer manufactures a complete line of CATV equipment featuring two models of Multi-Vendor Compatible addressable converters. The most advanced addressable converter offers volume control, integrated IPPV and downline loadable system parameters including output channel.

## Scientific Atlanta

**Scientific-Atlanta Inc. (404) 441-4000**  
**WATS(National) . . . . .(800) 722-2009**

One Technology Pkwy.

Atlanta, GA 30348

**PERSONNEL:** William Johnson, CEO; Sidney Topol, Chairman of the Board; John Levergood, Chief Operating Officer; Larry Bradner, Div. President/

Broadband Comm.

**REGIONAL OFFICES:** Denver: 61 Inverness Dr. East, Ste.100, Englewood, CO 80112; Fairlawn: 2100 Route 208, Fairlawn, NJ 07410; Indianapolis: 8755 Guion Rd., Ste. G, Indianapolis, IN 46268; St. Louis: Copper Bend South, 926 S. 59th St., Belleville, IL 62223.

**DESCRIPTION:** Complete line of cable TV products including earth stations and receivers, low noise converters, headend electronics, distribution products, taps and passives, coaxial cable, set-top terminals, status monitoring systems, fiber optic distribution systems, and Off-Premises Systems.



**Zenith Cable . . . . .(312) 391-7002**  
**Products Div.**

1000 Milwaukee Ave.

Glenview, IL 60025

**PERSONNEL:** James Faust, President; Vito Brugliera, VP/Mktg-Product Division; Robert Cunningham, VP/Sales; John Bowler, Vice President-Operations

**REGIONAL OFFICES:** 1130 E. Sleepy Hollow, Ste. A, Olathe, KS 66062, (913) 764-5554, Michael Adams; Londonderry Professional Park, Ste. 4B, Route 102, Londonderry, NH 03053, (603) 434-2830, Barry Hardek; Zenith Radio Canada, Ltd., STV/CATV Div., 1020 Islington Ave., Toronto, ONT M8Z 5X5, (416) 231-4171, Glen Andrews; 31 Ambleside Court, Danville, CA 94526, (415) 820-0161, Charles Auer; Suite 234, 2400 Pleasant Hill Road, Duluth, GA 30093 (404) 497-9530 or 497-9619, Jeffrey M. Grant; Room 384, 1000 Milwaukee Avenue, Glenview, IL 60025, (312) 391-8881, G.L. Wright.

**DESCRIPTION:** Zenith offers a complete line of cable products including Z-TAC baseband addressable decoders, PM RF addressable converters and RF converters. Pay-Master add-on decoders, impulse pay-per-view (IPPV) systems. Z-View for two-way cable system; Phonevision/ANI telephone system for one-way cable systems. SSAVI, STV and MMDS addressable baseband decoders; Z-LAN data and communications products; PCCII multi-brand remote control and SuperSwitch auto A/B switch.



# Addressability: burgeoning off-premise approach

For years now, cable system operators have wrestled with the decision of whether to utilize traditional trap technology or upgrade to addressable descramblers. It's never been a simple decision because there are benefits and pitfalls to each approach.

By now, the issue of traps vs. addressability is a well-worn debate. Consumers love trapped systems because there's no need for a converter if the subscriber has a cable-ready TV set. The remote control unit that came with the TV works; VCRs installed in the system have no problem recording one channel while the TV is tuned to a different one; and subscribers can split the signal to a second or even a third set with a minimum of coax and hassle.

## The shortfalls

But cable operators have found traps to be easily defeated. They're labor intensive in that every time a subscriber requests a service change or upgrade, it costs the operator to roll a truck and send out a technician to add or remove a trap, and they don't accommodate impulse pay-per-view (IPPV).

That's why addressability was invented. Operators can remotely control a subscriber's service from the headend or main office, providing subscribers with nearly instantaneous service changes, connects or disconnects. But the set-top box irritates and frustrates subscribers who purchase full-featured TVs and VCRs because the set-top tuner becomes a programming bottleneck.

Finally, what operators have been searching for—a good, reliable technology that marries the consumer friendliness of traps with the operating convenience of addressability—is beginning to gain a foothold of support from industry vendors.

Stepped-up operator interest in so-called off-premise addressable technol-

ogy has created a groundswell of product introduction from not only small entrepreneurial niche companies, but the mainstream suppliers as well. After years of gestation, previous attempts and failures, it appears that once again off-premise addressability has been legitimized.

"I believe more than ever it's a solution we absolutely need," says Jim Chiddix, senior vice president engi-

"This is not considered a backburner project," says Maloney. "We're serious about it. We definitely want to try it in the field," he adds. In fact, a potential customer has already been identified, but the location of the test has not yet been determined, says Ed Edenbach, vice president of marketing for Jerrold's subscriber systems division.

## Overwhelmed in Anaheim

S-A has already introduced its interdiction-type, pole-mounted addressable device at last year's Western Show in Anaheim. That device, which was developed with the input from several operators, received tremendous interest at the time and still does today, says Jack Bryant, S-A's market manager in the subscriber systems group and the man in charge of marketing the product. "I walked away (from the Western Show) overwhelmed," he says. "There's tremendous interest in providing a friendly solution to the consumer electronic interface issue."

S-A's approach essentially replaces the tap in the distribution system, says Bryant. Signals are generated in the headend in an unscrambled manner and interfering carriers are injected on those signals the subscriber doesn't subscribe to.

A "subscriber module" is dedicated to each of the four ports and each module has four voltage controlled oscillators which injects the carrier on the denied channels. Three levels of jamming effectiveness is available, depending upon channel loading. For example, if the operator wants high security, 16 channels can be affected (four in each module); medium security can be applied to 28 channels; while 35 channels can be affected with lower levels of security. The unit is slated to be field tested in three different locations beginning this autumn, says Bryant.

In his travels, Bryant has shown the

Finally, what operators have been searching for—a good, reliable technology that marries the consumer friendliness of traps with the operating convenience of addressability—is beginning to gain a foothold of support from industry vendors.

neering and technology at American Television and Communications. But Chiddix remains concerned about reliability and the cost of off-premise gear.

## Interest is burgeoning

Nevertheless, industry heavyweights Scientific-Atlanta and Jerrold have now joined the likes of Midwest CATV, AM Communications, Eagle Comtronics and Blonder-Tongue Laboratories in offering viable product meant for either pole or side-of-house mounting.

Jerrold will show its concept for the first time at the National Show in Dallas. According to Dan Maloney, Jerrold's director of product management, the device has been designed to be an all-purpose control system that will accommodate positive traps, negative traps, jammers, IPPV or on-channel descramblers.



# Jerrold Impulse 7000 Series

## ...Push-button response without a sidecar

The name says it all: Jerrold IMPULSE 7000—tomorrow's addressable converter available today.

That's because our field-proven store-and-forward technology has been placed inside a new, sleek design that is 33% smaller than its impulse predecessors. In fact, with its tiny footprint and hi-tech look, this new converter will sit smartly atop a portable TV or blend attractively into any home entertainment system.

And, with features like volume con-

trol, last channel recall, plus, of course, push-button impulse ordering, the IMPULSE 7000 is the new star of the home entertainment scene.

To learn more about this exciting new series of converters—which are available in standard RF, volume control and baseband—contact your Jerrold account representative or call or write Jerrold Division, General Instrument Corporation, 2200 Byberry Road, Hatboro, PA 19040. (215) 674-4800.

## JERROLD

... where innovation is a tradition

See us at the NCTA Show, Booth #1800.

## GENERAL INSTRUMENT



device to a total of 27 or 28 MSOs. He says only two of those showed no interest in the approach. "I think that's indicative of the overall interest in the technology." That is arguably the biggest difference between now and a year ago, when most interest in the approach was expressed by small-system operators or by systems located in high churn areas.

### Across the board interest

Across-the-board interest has also been shown for AM Communications' Tier Guard product as well, according to Mark Carter, marketing manager of AM's CATV division. Tier Guard—which can control two to 16 channels, plus turn service on and off—has gained the attention of several systems, including the Lenfest system in Oakland, a large, densely populated system.

In areas where operators are concerned about theft, Drop Guard provides all the security a system needs, says Carter. Drop Guard, essentially an on/off switch located in an active tap, is being used both in Oakland and in a rural tapped-trunk system in West Virginia, where truck rolls for connects and disconnects can easily become 160-mile round-trips.

"Interest in these products has really mushroomed," says Carter. "I think we're going to see the converter go away almost completely because cable-ready equipment will be almost 100 percent penetrated in about 7 years. I give converters about another 5 years," he adds.

### Yet another iteration

Eagle Comtronics, which continues to profit from traps' friendliness despite numerous surveys and forecasts that have shown expected downturns in trap sales, recently joined the party by introducing its version of the house-mounted addressable trap system and enclosure at this year's Texas Show.

Eagle's unit, which has been undergoing field tests in Ohio and New York since last year, has been met with "excellent response," says Joe Ostuni, vice president. In fact, the first production units should have started rolling off the line at the end of last month. "It's definitely a 'go' project," he says.

Eagle's unit is unique in that it provides for IPPV via a hard-wire autodialer. Combined with the store-and-forward method of data collection, the device gets around the drawback long

associated with traps—the inability to provide for IPPV. "This device does everything a set-top does, plus it's user-friendly," says Ostuni. It provides eight tiers of control and any number of channels can be assigned to a tier, Ostuni says.

Midwest CATV, which made an auspicious entry into this segment of the market by distributing Syrcuits'

All the activity  
surrounding these  
products bodes well for  
the future of  
addressability and  
shines a few rays of  
light into the dark  
corner of consumer  
electronic  
incompatibility that  
frustrates so many  
cable subscribers.

Matrix outdoor addressable box, has been struggling to overcome some production problems in order to deliver as many units as have been demanded by operators eager to test the device. After rolling out Matrix in a small rural Alabama system last fall (see "Off-premise addressability finds success stories," *CED*, November 1988, p.52), Midwest has been plagued by insufficient production capacity.

### Second source

However, that problem should be short-lived, according to Chris Sophinos, chief operating officer of Midwest CATV, now that a second source has been identified. Midwest signed a licensing agreement with Syrcuits that allows Midwest to find a second manufacturer of the product. According to Sophinos, an agreement with Antronix has been hammered out whereby Antronix will manufacture up to 5,000 units per month overseas.

"We've been unable to fulfill all the

interest operators have shown," says Sophinos. In fact, there were so few available units that Midwest didn't even display Matrix at the Texas Show. "There have been several operators who wanted to try 50 or 100 boxes," says Sophinos. With the added production capacity, Midwest hopes to be able to honor those requests, as well as full-fledged orders, he says.

### Coming to a large system

In fact, Sophinos expects to ink a deal with a large MSO to install Matrix in a system consisting of more than 150,000 subs. In addition, Com-Link, the company that rolled out Matrix in Alabama, has placed a second order with Midwest for more Matrix units, plus a headend. "To me, that's the best testimonial you can receive about a product," says Sophinos. "We're excited about what's happening."

To assuage fears that off-premise equipment can cause problems with operators concerned about signal leakage and the upcoming compliance deadline, Midwest had Matrix tested by an independent laboratory. ESC Corp. took Matrix out into the field and configured the unit in various ways. A total of 18 different simulations were performed and each time the device operated well within FCC specifications, says Sophinos.

### Strategic value

All the activity surrounding these products bodes well for the future of addressability and shines a few rays of light into the dark corner of consumer electronic incompatibility that frustrates so many cable subscribers. Although it's difficult to quantify subscriber satisfaction, operators like ATC's Chiddix note the strategic advantage of keeping subs happy with their cable service.

"Off-premise technology sets us up for the future and a competitive environment," says Chiddix. It gets cable system personnel out of the home, it removes cable system capital from the home and allows a "telephone jack" mentality where subscribers can simply plug into a cable jack and receive programming, no matter what type of receiver equipment he owns. "That's where we need to be a decade from now," says Chiddix.

If the hardware manufacturers do their homework, it may not take that long. ■

—Roger Brown



Channel

2

Channel

3

Channels

2&3



# System Flexibility

Pioneer will consolidate your inventory like never before.

The BA-6000 **Multi-Vendor Compatible** addressable converter easily integrates into a Jerrold, Oak, Hamlin or Sylvania scrambling system. Over one million multi-vendor compatible converters operating in the field give you the confidence it works. Once you see the advanced BA-6000, you may even decide to changeout your entire system.

The BA-6000's **output channel is downline loadable**. This gives you the flexibility to transfer converters between systems—a perfect solution for MSO's managing systems with different converter output channel requirements.

The Pioneer BA-6000 Multi-Vendor Compatible addressable converter—one converter that does the work of eight.

Call (800) 421-6450 to discover just how flexible and compatible the Pioneer BA-6000 can be for you.

**Pioneer BA-6000. The Choice is Yours.**



**PIONEER®**

PIONEER COMMUNICATIONS OF AMERICA, INC.

600 East Crescent Ave. • Upper Saddle River, NJ 07458  
(201) 327-6400 • Outside New Jersey (800) 421-6450

© 1988

Reader Service Number 79

See us at the NCTA Booth 2400

## TRAP CALLBOOK

The following companies have paid a fee to have their listing appear in the Trap Callbook.

## ANIXTER COMMUNICATIONS®

**Anixter Cable TV . . . (312) 677-2600**  
**WATS(National). . . (800) 323-8166**

4711 Golf Road

One Concourse Plaza

Skokie, IL 60076

PERSONNEL: John Egan, President and CEO; Gordon Halverson, Executive Vice President; Marty Ingram, VP/ Product Management & Mktg.; Dean DeBaise, VP/New Business Development

REGIONAL OFFICES: Anaheim: 4905

E. Hunter Ave., Anaheim, CA 92807,

(714) 779-0500, FAX (714) 777-1527;

Atlanta: 550 Old Peach Tree Rd.,

Suwanee, GA 30174, (404) 995-5110,

FAX (404) 963-5342; Chicago: 888

Thomas Dr., Bensenville, IL 60106,

(312) 350-7788, FAX (312) 350-7840;

Cleveland: 8060 Snowville Road,

Brecksville, OH 44141 (216) 526-0919;

Dallas: 1620 Crosby Road, Suite 115,

Carrollton, TX 75006, (214) 446-7337,

FAX (214) 242-6079; Denver: 8101 E.

Prentice, Ste. 210, Englewood, CO

80111, (303) 740-8949; Houston: 4799

Eastpark Drive, Houston, TX 77028-

5997 (713) 674-1111; Iron Mountain:

1023 River Ave., Iron Mountain, MI

49801, (906) 774-4111, FAX (906) 774-

6287; Long Island: 7 Michael Ave.,

East Farmingdale, NY 11735, (516)

293-7788, FAX; (516) 293-7503;

Orlando: 2901 Titan Row, Suite 124,

Orlando, FL 32809 (407) 240-1888;

Seattle: 18435 Olympic Ave. South,

Seattle, WA 98188, (206) 251-6760,

FAX (206) 251-0846; Wharton: 321

Richard Mine Rd., Wharton, NJ 07885,

(201) 328-0980, FAX (201) 328-1267.

DESCRIPTION: Anixter Cable TV is

a supply specialist to the CATV

industry. A complete line of cable

television products is offered, including

fiber optic cable, connectors, electronics

and apparatus, satellite receiving

equipment, headend equipment,

subscriber devices, distribution electronics, coaxial cable and connectors, aerial and underground construction material, system passives, drop and installation material, tools and safety equipment, and test equipment.

## Northern catv sales, inc.

**Arcom/Northern . . . (315) 426-1455**  
**CATV Sales**

**WATS(National). . . (800) 448-1655**

**FAX . . . . . (315) 422-2963**

PO Box 6729

Syracuse, NY 13217

PERSONNEL: Greg Tresness, Manager

Tech Sales; Ed Manley, New Products

Manager

DESCRIPTION: Distributor of CATV

products and manufacturer of Arcom

double density traps, decoding filters

and tier traps.

## AUGAT AUGAT COMMUNICATIONS GROUP INC.

**Augat/LRC . . . . . (607) 739-3844**  
**Electronics Inc.**

**FAX . . . . . (607) 739-0106**

P.O. Box 111

Horseheads, NY 14845

PERSONNEL: Berry Cokely,

Operations Manager; Leonard DeRenzo,

Director of Sales; Ken Wood, Director/

Product Development

DESCRIPTION: LRC Electronics, Inc.

is a major supplier of coaxial cable

connectors, traps and RF leakage

detectors.



**Cable Link, Inc.. . . (614) 221-3131**

**FAX . . . . . (614) 222-0581**

280 Cozzins St.

Columbus, OH 43215

PERSONNEL: E. Jack Davis, President;

Bill Holehouse, Vice President of Sales;

'Zack' Zekri, Sr. Account Executive;

Stan Smith, Sr. Account Executive;

Pete Tippetan, Sr. Account Executive

REGIONAL OFFICES: Lucy Espinoza,

8610 Broadway St., Suite 210, San

Antonio, TX 78217 (512) 822-1303/

1350

DESCRIPTION: Cable Link Inc. buys,

refurbishes and sells CATV equipment.

Our products include addressable, non-

addressable converters, linegear,

headend, traps, passives, parts, and

hardware. We also repair Oak and

Jerrold addressable converters. Also

CAD Map Design, Character Generator

Sales.



**Cable Services . . . (717) 323-8518**  
**Company, Inc.**

**WATS(National). . . (800) 233-8452**

**WATS(State). . . . . (800) 332-8545**

**FAX . . . . . (717) 322-5373**

2113 Marydale Avenue

Williamsport, PA 17701-1498

PERSONNEL: John B. Roskowski,

President; George Ferguson, Vice

President; John M. Roskowski, Vice

President Construction; Harry A. Wahl,

Vice President-Turnkey Sales; Robert

Brantlinger, Director/Marketing

DESCRIPTION: Complete fiber optic,

coax, or LAN, turnkey construction

and supply company. Services include

aerial and underground construction,

splicing, house drop installation and

headend installation. Also supplier of

all major manufacturers and in house

design, repair and engineering facilities.

## D R D Enterprises, Inc.

**DRD Enterprises Inc.. .315-457-0813**

## TRAP CALLBOOK

**WATS(National)**. . . .(800) 541-5893  
7143 Henry Clay Boulevard  
Liverpool, NY 13088  
PERSONNEL: Doc D'Alfonso; Shawna Earle  
DESCRIPTION: Manufacturer's representative.



**Eagle** . . . . .(315) 622-3402  
**Comtronics, Inc.**

**WATS(National)**. . . .(800) 448-7474  
4562 Waterhouse Road  
Clay, NY 13041

PERSONNEL: Alan Devendorf, President; Joseph Ostuni, VP/Sales and Marketing; Chester Syp, National Sales Manager

DESCRIPTION: Micro Series traps and decoding filters, encoders with extra pre-emphasis, channel droppers, metal shields, directional taps, and addressable trap switches with Impulse Pay-Per-View.



**Gamco Industries**. . .(201) 381-0700  
**WATS(National)**. . . .(800) 221-1367  
**FAX** . . . . .(201) 381-6168

19 Walnut Avenue  
Clark, NJ 07066  
PERSONNEL: Fred Whiting, Executive Vice President; Sheila O'Sullivan, VP-Sales & Mktg.; Carmine Amatucci, National Sales Manager; Frank Kanobel, Sales Rep.; Tony Taylor, VP of Engineering

DESCRIPTION: Manufacture passive and active line equipment: line extenders, channel droppers, passive line and trunk amplifiers, subscriber

traps, speciality filters, band pass and decoding filters. A full line of drop material in stock. Distributor of ISS processing equipment.

## INTERCEPT

**Intercept** . . . . .(201) 279-2544  
**Communication**

85 5th Ave., Bldg. #16  
Paterson, NJ 07524

PERSONNEL: George Adbelmessieh, President; Peter Parikh, Executive V.P.

REGIONAL OFFICES: SALES

OFFICE: Intercept Sales, Gedi Corporate Park, Englishtown, NJ 07726; (201) 446-1010; WATS(National) (800) 338-8727; Kenneth Augustine, Vice President, Sales.

DESCRIPTION: Engineers and manufacturers of pay-TV security traps, super traps, tier and multi-channel traps, scramblers, filters, keylock, converters, pedestals, directional taps, subscriber drop passives and cable speciality products.



A division of Midwest Corporation

*More than supplies. Solutions.*

**Midwest CATV** . . . . .(304) 343-8874  
**A Division of Midwest Corporation**

**WATS(National)**. . . .(800) 532-2288  
**FAX** . . . . .(304) 346-0624

1012 Kanawha Blvd. East  
P O Box 271

Charleston, WV 25321  
PERSONNEL: Jerry Thompson, President; Christopher Sophinos, V.P./Chief Operating Officer; John Johnson, Purchasing Manager

REGIONAL OFFICES: Northeast: James McCauley, Vice President, Tri-County Business Campus, 72 Robinson

Street, Pottstown, PA 19464, (800) 458-4524; East: Jack Crouse, Vice President, P.O. Box 226, Clarksburg, WV 26301, (800) 532-2288; South: Elijah Midkiff, Vice President, 2697 International Parkway III, Suite 128, Virginia Beach, VA 23452, (800) 643-2288; Southwest: Bill Cody, Sales Manager, 2118 Wall Street, Suite 800, Garland, TX (800) 421-4334; Ocala Distribution Center, Scott Wells, Sales Manager, 5150 West Highway 40, Ocala FL 32675, (800) 433-3765; Central: Bill Whiteley, Vice President, P.O. Box 4519, Lafayette, IN 47903, (800) 428-7596; West: Peter Hineson, Sales Representative, Denver Corp. Tower III, 7900 East Union, Suite 840, Denver, CO 80237, (800) 232-9378.  
DESCRIPTION: Distributor of a complete line of cable TV equipment: antennas, headend, distribution electronics, passives, taps, connectors, coaxial cable, construction material, towers, drop material, enclosures, pedestals and racks, power supplies, strand, test equipment, tools, traps, safety equipment, fiber optic cable, subscriber descrambling converters, and all the accessories necessary for the cable operator. Also the Matrix system, an off-premise addressable trap system.



**RMS Electronics Inc.** . .(201) 288-8833  
**WATS(National)**. . . .(800) 223-8312  
621 Route 46

Hasbrouck Heights, NJ 07604  
PERSONNEL: Joseph F. Bradway, Chairman/CEO; Doug Light, VP/Sales & Marketing; Gary Napolitano, VP/Finance; Fred Mucciardi, VP/Operations  
DESCRIPTION: Standby, inverter and AC regulated power supplies, 550 MHz & 600 MHz power passing line splitters, couplers and directional taps; drop couplers and splitters; pedestals, traps and decoding filters, scramblers, matching transformers and filters; attenuators; aluminum and 'F' and 'N' connectors; cable preparation tools.



## WHAT'S AHEAD

# SCTE

**May 9** *The Chattahoochee Chapter* will present a technical seminar on "Power Supplies." Call Jack Connolly, (912) 741-5068 for details.

**May 9** *Central Illinois Chapter* will hold a technical seminar on "CLI/FCC Requirements and Signal Leakage Programs and Devices" at the Sheraton Inn in Bloomington, Ill. Call Tony Lasher, (217) 784-5518 for more information.

**May 10** *North County Chapter* will hold a technical seminar at the Sheraton Midway Hotel in St. Paul, Minn. The topic is BCT/E Category III, "Transportation Systems" with Dane Walker of Hughes Microwave. Call Douglas Ceballos, (612) 522-5200, ext. 705 for info.

**May 10** *Caribbean Area Chapter* will hold a technical seminar on BCT/E Category I, "Signal Processing Centers" presented by Scientific-Atlanta. Location for the seminar is Cablevision of Mayaguez in Mayaguez, Puerto Rico. For details call Jerry Fitz, (809) 766-0909.

**May 10** *Greater Chicago Chapter* will present a technical seminar at the Embassy Suites, Schaumburg, Ill. The topic is "Signal Leakage-CLI" with Richard Amell of Metrovision, Robert V.C. Dickinson of Dovetail Systems, Jim Poynton of Raychem Corp., Mike Berry of Wavetek and Don Runzo of ComSonics. Call Joe Thomas, (312) 362-6110 for information.

**May 10** *Mount Rainier Meeting Group* will host a technical seminar on "Fiber Optics." Call Sally Kinsman, (206) 867-1433 for location and other details.

**May 11** *Gateway Chapter* will host a BCT/E Category VI Review on "Terminal

Devices," given by Scientific-Atlanta, at Joe Hanon's Restaurant, Maryland Heights, Mo. For info call Darrell Diel, (314) 576-4446.

**May 12** *Rocky Mountain Chapter* will host a technical seminar on "Distribution Troubleshooting," "CLI and Signal Leakage" and "Magnavox Mobile Training Van" with Eric Himes of Magnavox and Ron Wolfe of ATC. Call Rikki Lee, (303) 792-0023 for details.

**May 13** *Cactus Chapter* will present a technical seminar. Call Harold Mackey Jr., (602) 866-0072, ext. 282 for info.

**May 17** *North Central Texas Chapter* will hold a technical seminar. For more information call M.J. Jackson, (800) 528-5567.

**May 17** *Razorback Chapter* will hold a technical seminar at the Days Inn, Little Rock, Ark. For info, call Jim Dickerson, (501) 777-4684.

**May 17** *Dairyland Meeting Group* will present a technical seminar at the West Bend Royale Hotel, West Bend, Wis., on "Fiber Optics." Call Jeff Spence, (414) 738-3180 for details.

**May 17-18** *Ohio Valley Chapter* will host a technical seminar. Call Bill Ricker, (614) 236-1292 for details.

**May 18** *Oklahoma Chapter* will hold a technical seminar on "System Distortions of All Kinds," with Fred Rogers of Quality RF Services Inc. The seminar will be held at the Applewoods Restaurant, Oklahoma City, Okla. For info call (405) 353-2250.

**May 18** *Central California Meeting Group* will hold a technical seminar. Call Andrew Valles, (209) 453-7791 for details.

**May 18** *Golden Gate Chapter* will hold a technical event on "System Powering."

For more info call Sam Towne, (408) 452-9100.

**May 19** *Heart of America Chapter* will present a technical seminar. BCT/E Examinations are tentatively scheduled for Categories I, II and III. For more info call Wayne Hall, (816) 942-3715.

**May 20** *Great Plains Meeting Group* will conduct a tour of the Nebraska Educational TV Center in Lincoln, Neb. The tour covers the center's studio, control rooms, uplink and library. Call Jennifer Hays, (402) 333-6484 for info.

**May 24** *North County Chapter* is tentatively scheduling BCT/E examinations. Call Douglas Ceballos, (612) 522-5200, ext. 705 for more details.

**May 25** *Upstate New York Meeting Group* will hold a technical seminar on "CLI" in Rochester, N.Y. For details call Ed Pickett, (716) 325-1111.

**May 30** *Satellite Tele-Seminar Program* will air "Frontline: Senior Cable Engineers (Part II)" with Wendell Bailey of NCTA, Vito Brugliera of Zenith, Tom Elliot of TCI, Dave Large of Raynet and Joe Van Loan, consultant. Videotaped at Cable-Tec Expo '88 in San Francisco, the program will air from noon to 1 p.m. Eastern time on Satcom F3R, transponder 7.

**May 31** *Piedmont Chapter* will hold a technical seminar. Call Rick Hollowell, (919) 968-4631 for details.

**June 3** *Razorback Chapter* will conduct a technical seminar at the Days Inn, Little Rock, Ark. on "Installer Seminar." For more info call Jim Dickerson, (501) 777-4684.

**June 6** *Chattahoochee Chapter* is tentatively scheduling BCT/E examinations. Call Jack Connolly, (912) 741-5068 for details.

## WHAT'S AHEAD

### MAGNAVOX

CATV SYSTEMS CO.  
A DIVISION OF NORTH AMERICAN PHILIPS CORPORATION  
100 FAIRGROUNDS DR., MANLUS, NY 13104

The Magnavox CATV Systems mobile training center is a fully-equipped laboratory on wheels for cable training. The three-day seminars combine instruction in theory and practical hands-on training, using gear and test equipment common throughout the industry. The fee is \$300.

**May 2-4 Magnavox Mobile**

Training will be in Los Angeles, Calif. Call Amy Costello Haube, (800) 448-5171 (in NY state, (800) 522-7464) to register, or for additional info.

**May 9-11 Magnavox Mobile Training** van will be in Phoenix, Ariz. Call Amy Costello Haube, (800) 522-7464 to register, or for additional info.

**May 15-17 Magnavox Mobile Training** van will be in Denver, Colo. Call Amy Costello Haube, (800) 448-5171 to register, or for additional info.

**June 5-7 Magnavox Mobile Training** will be held in Dallas, Texas. Call Amy Costello Haube, (800) 448-5171 to register, or for additional info.



**Illinois Bell**  
AN AMERITECH COMPANY

Illinois Bell offers a two-and-a-half-day course in Fiber Optic Communications that emphasizes practical application and implementation. The course is designed for those responsible for planning,

engineering, evaluating, selecting, installing and/or maintaining a fiber optic communications system. The fee is \$775.

**May 16-18 Illinois Bell Fiber Optic Communications** seminar will be held in Lake

Tahoe, Nev. Call (312) 655-3096 for registration or info.

**June 6-8 Illinois Bell Fiber Optic Communications** seminar will be held in Westmont, Ill. Call (312) 655-3096 for registration or info.



C-COR Electronics "state of the art" seminars are three-day events designed to instruct relatively new technicians in basic theory, installation and maintenance of cable TV systems. Attendance is limited to a

maximum of three persons from one system. The fee is \$195.

**May 23-25 C-COR Electronics Seminar** will be held in San Francisco, Calif. Call Teresa Harshbarger, (800) 233-2267, ext. 326 to

register or for additional info.

**June 20-22 C-COR Electronics Seminar** will be held in Pittsburgh, Pa. Call Teresa Harshbarger, (800) 233-2267, ext. 326 to register or for details.

**Etc.**

**May 15-16 Fibertron** will be conducting a free fiber optic seminar at the Heritage Inn on Imperial Highway in Fullerton, Calif. The seminar is entitled "What's New and Who's Who in Fiber Optics." Call Denise Weber, (213) 690-0670 for details.

**June 1-2 The HDTV Newsletter and Meckler Conference Management** will hold a HDTV Conference and Exhibition at the Marriott Marquis in New York City. In addition, a preconference session entitled "Introduction to HDTV" will be held on May 31 to present the basics of HDTV. For additional info call Marilyn Reed, (800) 635-5537.

**June 5-9 Hughes Aircraft**

**Company's Microwave Communications Products** will hold a technical training seminar on its AML microwave equipment for local signal distribution. The June seminar will be on "Channelized Equipment." For more info call Seminar Registrar, (213) 517-6244, or toll-free outside of Calif. and Alaska, (800) 227-7359, ext. 6244.

**June 8-9 ComNet Engineering** will present a seminar on the design and applications of broadband LANs at the Sheraton Premiere, Tysons Corner, Va. The seminar, vendor independent of user equipment, will focus on broadband theory and design

pursuant to IEEE 802.7, MAP/ TOP and NTCA standards. The fee is \$795. For further details call John Gutierrez, (512) 892-2085.

**June 26-28 Northeast Cable Television** will hold a trade show and technical seminars on "Rebuild and Upgrade" at the Roaring Brook Ranch, Lake George, N.Y. BCT/E exams will be also be administered. Call Bob Levy, (518) 474-1324 for details.

**June 26-29 Siecor** will hold a course on "Fiber Optic Installation and Splicing for Cable TV Applications" at Siecor's training facility in Hickory, N.C. For details call Lynn Earle at (704) 327-5539.



Do you have a technical event or seminar you'd like to publicize? Just send a notice of your event, including

information on fees, a contact name and phone number and a brief description of the subject matter to:

CED, Event  
600 S. Cherry St., Ste. 400  
Denver, CO 80222  
(303) 393-7449.

# CLASSIFIEDS

## HELP WANTED

### SALES ENGINEER

(State College, PA)

Opportunity available at C-COR Electronics, a rapidly growing electronics company, to provide technical support to customers (in-house or on-site) in our CATV Sales Department. Sales engineer will provide C-COR's Sales & Marketing with engineering support to maintain and expand markets for C-COR cable products.

B.S.E.E. or equivalent plus 3-5 years sales engineering experience with cable customers is required. Effective communication skills, willingness to travel, ability to perform technical training, and effective interpersonal skills are prerequisites for these openings.

Competitive salary, sales incentives, benefits and relocation packages available for qualified individuals. Send resume with salary history in confidence to:

**Director, Human Resources**  
**C-COR ELECTRONICS, INC.**  
 60 Decibel Rd.  
 State College, PA 16801  
 EOE M/F/H/V

### SERVICE TECHNICIAN

Part of a large MSO located in Central Jersey is looking for a service technician who can trouble shoot and has knowledge of test equipment. We are an equal opportunity employer.

Send resume to:

**CED 050189**

### TECHNICAL SUPERVISOR

Growing MSO needs a strong individual who has 4 to 6 years of technical supervisory experience. Responsible for maintaining high quality cable service, supervision and training of 14-member technical staff and related administrative functions. Supervisory experience in a union environment helpful. Send resume and salary requirements to:

**Personnel Department**  
**Heritage Cablevision**  
 16830 Edson Road  
 Mishawaka, IN 46545  
 EOE

**Leader in the placement of Cable Television Professionals**  
 Call toll free 1-800/433-2160; In Texas call collect 817/599-7623.

#### TECHNICAL MANAGEMENT

1. DIR ENG, E, 60K
2. CH ENG, E, 50K
3. REG ENG, E, 45K
4. DES ENG, W, 30K
5. CH ENG, MW, 42K
6. CH ENG, MW, 40K
7. CH ENG, SE, 40K
8. CH TCH, SE, 27K
9. CH TCH, W, 30K
10. CONST MGR, E, 40K
11. DES ENG, SE, 25K
12. CORP ENG, SE, 35K
13. CONST MGR, NE, 40K
14. CH TCH, NE, 34K
15. CH TCH, N, 30K

#### TECHNICIANS

- HDEND, E, 13/HR
- HDEND, SW, 30K
- HDEND, SE, 35K
- LN TCH, TX, 10/HR
- LN TCH, E, 25K
- LN TCH, E, 11/HR
- LN TCH, NE, 12/HR
- LN TCH, E, 13/HR
- SW TCH, MW, 11/HR
- LN TCH, MW, 9/HR
- LN TCH, SW, 20K
- LD TCH, SE, 11/HR
- LN TCH, W, 13/HR
- SW TCH, SE, 10/HR
- VEDEO, W, 30K



### JIM YOUNG & ASSOCIATES

One Young Plaza 1235 Ranger Highway Weatherford, TX 76087  
 Call for information about these and many other opportunities nationwide.

### C4 MEDIA CABLE has openings for ENGINEERS - TECHNICIANS

Excellent career opportunities exist with one of the industry's fastest growing MSO's. We have immediate openings in our VA, NC, SC, TN and GA operations for strong self-motivated individuals with engineering and construction backgrounds to fill the positions of:

**REGIONAL ENGINEER**—Prior construction and technical management experience, proven technical abilities, and strong administrative and organizational skills are a must. VA location.

**DISTRICT ENGINEER**—Must be technically well versed and possess prior construction supervision and technical operations experience. VA location.

**REGIONAL FIELD TECHNICIANS**—A minimum of 3 years experience with demonstrated abilities in headend construction, basic plant design, and system activation and sweep is necessary for these positions in VA and NC.

Excellent salary and benefits including dental, vision and company vehicle.

Please send resume and salary history to:

**Scott Madison**  
 Director of Engineering  
 C4 Media Cable  
 450 Maple Ave., East Ste. 301  
 Vienna, VA 22180

EOE M/F

### How to respond to a Blind Box:

CV (Blind Box No.) c/o CableVision  
 600 So. Cherry St., Suite 400  
 Denver, CO 80222

CATV Construction needs experienced people to work full time in Southern California and Arizona as U.G. and Aerial Crew Chiefs, Splicers, Lineman, and Installers. Good pay and benefits. Send resume to 36-630 Cathedral Canyon Drive, Cathedral City, CA 92234.

### Baker Scott & Co. EXECUTIVE SEARCH

1259 Route 46 Parsippany, NJ 07054 201 263-3355

**Specialists in the COMMUNICATIONS  
 INDUSTRY**

CABLE TV; BROADCAST TELECOMMUNICATIONS  
 DIVISION DIVISION

POSITIONS AVAILABLE AT ALL LEVELS OF  
 MANAGEMENT. COAST TO COAST

Call or write in CONFIDENCE

FEE PAID

**"WE DON'T TALK CABLE, WE KNOW CABLE"**  
 PRINCIPALS DAVID ALLEN & JUDY BOUER



**EQUIPMENT FOR SALE/RENT**

**VIDEO SUPPLIES**  
 CABLES • CONNECTORS • CANARE • BELDEN • SWITCHCRAFT • D.A.S. • TIES •  
 BATTERIES • NEUTRIK • 60 INTERFACE BOXES • TAPE • 500 DIFF TAPE LABELS • GAPPERS  
 TAPE • CASES • PATCH BAYS • LIGHTS • ACOUSTIC FOAM  
 FORMS • MICROPHONES • SONEC • STANDS • MOUNTS  
 WIND SCREENS • ZEPPELINS • FIBRE OPTICS • RACKS  
 DUCT • REELS • TESTERS • FILTERS • CHEMICALS • TOOLS  
 ON AIR LIGHTS • DEGAUSSERS • INTERFACE DEVICES  
 HEADPHONES • CLIPS • SWITCHES • CAM & S-VHS CABLE

*Very Unique Professional Catalog FREE!*

**MARKERTEK VIDEO SUPPLY**  
 145 Ulster Ave., Saugerties, NY 12477 U.S.A.  
 TOLL FREE 1-800-522-2025  
 In NY: 914-246-3036

**Bucket Trucks—Used**  
 Telsta, Versa-Lift, Digger Derricks—10 in Stock. 30 other Utility Construction Trucks.  
 "We Buy and Sell"  
**Opdyke, Inc.** (Philadelphia Area)  
 3123 Bethlehem Pike (215) 721-4444  
 Hatfield, Pa. 19440

**WANTED: SURPLUS CABLE EQUIPMENT**  
 Jerrold, Oak, Hamlin & Scientific Atlanta equipment.  
**Highest Prices Paid**  
**Cable Equipment Brokerage Co.**  
**(818) 709-3724**

**QUALITY COUNTS**  
 (Precision Converter Repair)

We have found that both quality and integrity count. We know that you want to be able to count on your converter and decoder repair facility for just that. At SCI Service and Repair, we offer you both — integrity and quality.

SCI's repair expertise covers the following:

- All Jerrold addressables
- All Oak TC and Sigma addressables
- All Oak head-end
- All non-data addressables

Scientific Atlanta, Pioneer, Oak, Hamlin

**Benefits:**

- Turn-around on most orders is less than 3 weeks.
- Six-month limited warranty. • Recently modernized facilities.
- 99%+ perfect last 18 months — few warranty returns.

When Quality Counts . . . OUR QUALITY SHOWS  
**(619) 438-1518**

**SCI**

2265 Camino Vida Roble, Carlsbad, California 92008

**AERIAL BUCKET TRUCKS**

Large selection geared for CATV  
**STANDARD TRUCK & EQUIPMENT CO.**  
 1155 Hill St. S.E.  
 Atlanta, GA 30315  
 Phone: 1-800-241-9357 **BUCKET TRUCKS**



**WANTED TO PURCHASE**  
 Cable lasher • Used in good condition  
 Model C or J • Immediate need  
 Will consider renting  
**Bocco Cable**  
 24-14th St., Wheeling, WV 26003  
 304-233-0655

*Anthony's* **ANTHONY'S**  
 MANUFACTURING SERVICE

**PLOW BLADES**  
 Irrigation/Wire/Combination  
 For Any Machine—For Any Application

1-800-373-7306  
 (719) 475-PLOW P.O. Box 17701  
 Colorado Springs, CO 80935



**EMERGENCY ALERT SYSTEMS**

by  
**Idea/onics**

69 channels 14 day delivery  
 compatible with all headends  
 —AFFORDABLE—  
**(701) 786-3904**

24 and 88 channel units  
 also available

**BUSINESS DIRECTORY**

**TSB, Inc.**

- DESIGN, STRAND MAP, AS-BUILTS
- CAD DRAFTING SERVICE
- HEADEND RACKING AND RENOVATIONS
- CLI • AUDITS
- ONSIGHT TECHNICAL TRAINING
- STRUCTURAL ANALYSIS OF TOWERS

PO Box 244 Yankton, SD  
 (605) 665-1393 57078



**ColorView Services, Inc.**  
 800-824-1943 SINCE 1953

**CONVERTER REPAIR**

**REALISTIC TURNAROUND**  
 PROGRAMMABLE & ADDRESSABLE

JERROLD HAMLIN PANASONIC OAK SCIENTIFIC ATLANTA TEXSCAN

ASK ABOUT OUR PRICES! SIX MONTH WARRANTY!  
 ALBUQUERQUE, NEW MEXICO



### Anixter announces laser price reduction, abandons plans for multi-fiber AM product

Anixter Cable TV has lowered the price for the AT&T distributed feedback laser for use in cable TV systems, according to company President John Egan.

Previously, the Laser Link was priced at a flat \$30,000 per link. Now, however, the link will be priced between \$20,000 and \$35,000 each, with \$25,000 considered the median price, Egan said. The price reduction came about from higher production yields made possible because Anixter and AT&T have made significant strides in characterizing laser performance and can match lasers with requested specs.

In related news, Egan said it will be "at least a year" before significant advances are made in DFB lasers designed for analog uses. Previously, lasers were designed exclusively for digital applications. Because a new laser is in the works (expect an announcement concerning the performance capabilities of the new laser at the National Show later this month) Egan said Anixter has abandoned its investigation into offering a multi-fiber AM link.

In other news, AVCOM has introduced a new portable spectrum analyzer, the model PSA-65A. The PSA-65A covers frequencies through 1000

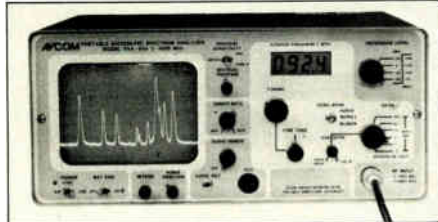

*Avcom's PSA-65A spectrum analyzer*

MHz in one sweep with a sensitivity greater than -90 dBm at narrow spans. The battery or line-operated analyzer includes frequency extenders to enable the PSA-65A to be used at Satcom and higher frequencies, audio demod for monitoring and log periodic antennas. The PSA-65A weighs 18 pounds and is priced at \$2,675. For more information call (804) 794-2500.

Available from **Microdyne Corp.** is the MAT II (Microdyne Automated Terminal). The fully automated receiving terminal allows users to receive programming from any geosynchronous satellite regardless of program,

transponder format or frequency. The system controller stores up to 199 presets and automatically switches channels, frequency, format, signal polarity and satellite. The MAT II can also be configured to turn on associated peripherals, such as scramblers, descramblers, printers, video recorders or cameras.

The system features the Microdyne 1100-BKR (M) satellite receiver, which can receive and process any C-band or Ku-band transponder accessible to domestic and commercial downlinks. The receiver is microprocessor controlled and uses front-panel controls to select the desired RF frequency. For details call (407) 231-6904.

**Lectro Products Inc.** has intro-



*Viewsonics coaxial cable stripper*

duced a 2 amp 30/60 VAC ferroresonant power supply. Named the Pee-Wee power supply (Model PSF-MMP-LXX-L), the unit weighs 13 pounds and features a 115 VAC plug-in line cord. Pee-Wee is also available in a rack mounted version. Call (800) 551-3790 or (404) 543-1904 for info.

Introduced by **Viewsonics** is the Coaxial Cable Stripper set for most RG6, RG59 and RG58 cable up to 0.310 outside diameter (jacket.) If further adjustment is needed, a hex allen wrench is located on the base of the Stripper. The price is \$14.95 each. For more information call (800) 645-7600. In New York call (516) 921-7080.

The **Black Magic Processor** series, from **Acunet Data Systems Inc.**, is a

channel deletion and reinsertion device. **Black Magic** allows users to delete a channel on a CATV, SMATV, or MATV system and reinsert any desired programming in its place. The series

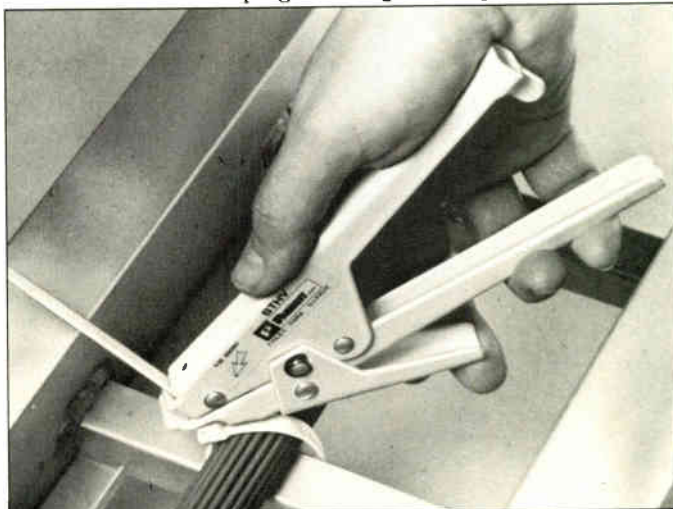

*Panduit Corp's STHV cable tie installation tool*

incorporates a deletion filter (Model 8612), a low noise processor and combining networks to enable users to install their own converter and descrambling equipment. Call (416) 427-0366 for info.

**E-Z Trench** has announced new carbide trenching blades which reportedly reduce drag by 40 percent. Two models are available, the J-1000 and J-2000. For more details call (803) 756-6444.

A new installation hand tool designed for Panduit® heavy and light cross section cable ties has been announced by **Panduit Corp., Electrical Group**. The STHV tool can be used to tension and provide cutoff for 0.30-inch and 0.35-inch width cable ties. It features a "Travel Stop" to limit the possibility of pinching the user's hand. For further info call (800) 777-3300.

**Kustom Products Marketing Inc.** has introduced the Remote Pak Remote Control Organizer for orderly storage of television, cable, VCR and compact disc player remote control units. The plastic unit measures 8½ inches by 8½ inches by 2¼ inches. Remote controls attach and remove from the organizer by use of velcro attached on the back side of the unit and on the Remote Pak. List price for the organizer is \$12.95. For details call (503) 231-7119.

**ESE** announced its new **Color/Digital Effects Character Generator**, the ES-CG89. The generator features





ESE's color/digital effects character generator, ES-CG89

a 16 color palette, four upper- and four lower-case fonts, 10 display styles and 30 pages of memory. The CG89 is a stand-alone unit, with internal or external genlock capability, priced at \$1,395. Call (213) 322-2136 for more info.

**Digital maps for AutoCAD**

A series of digital maps in AutoCAD format are now available for the continental United States from **American Digital Cartography**. Each map covers a geographic "quadrangle" of 7.5 minutes of latitude high by 7.5 minutes of longitude wide, which is an area of approximately 60 square miles. Pertinent information, such as highways, roads, rivers, shorelines, cities, towns, lakes, rivers and schools, is delineated on separate layers for specified use. The maps are priced from \$50 to \$338 per quadrangle map, depending on the



Microwave radio microlink

extent of information. For details call (414) 733-6678.

A new series of 18 and 23 GHz short haul microwave links has been introduced by **Microwave Radio Corp.** The Microwave Radio MicroLink II is an RF frequency synthesized system with a 0.003 percent frequency stability and UHF intermediate frequency. Audio and video are applied directly to the RF

head to eliminate the need for a controller. The systems are available in simplex, duplex and multiplex configurations with system gain from 167 dB. Both the MicroLink I and II can be supplied with antennas ranging from 15 inches up to 72 inches for domestic and international applications. Cost of the MicroLink series is \$7,500 to \$20,000 depending on system configurations. For more info call (508) 459-7655.

**Radiation Systems Inc., Mark Antennas Div.** has announced a full line of receive only antennas in both parabolic grid and solid configuration for use in ITFS, MMDS and MDS bands. Also offered is a full line of Bogner ITFS, MMDS and MDS transmit an-

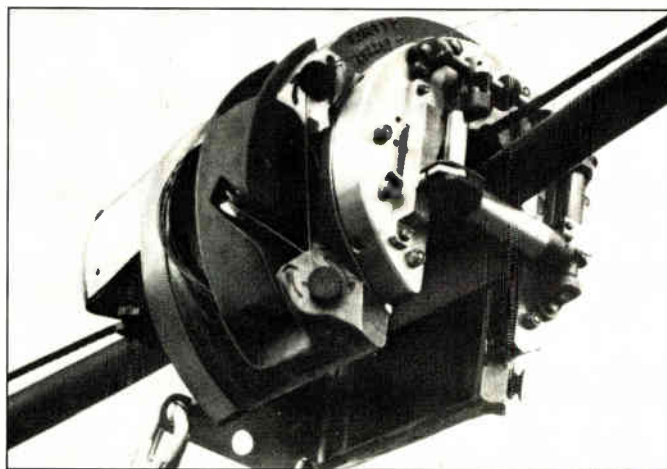

General Machine Product's GMP J2 lasher

tennas. Call (312) 790-3602 for details.

An aerial cable lasher which can accommodate a second cable with no field modification is available from **General Machine Products Co.** The J2 Lasher can be readied for dual

lashing using standard practices by depressing the strand roller knob and rotating it a quarter turn. Two or more cables can be lashed to one strand if the total diameter of the cable assembly is less than 3/4 inch diameter. The J2 Lasher features a strand drive wheel



**Energy Control System's protector AC powerline transient voltage suppressor** which fits all size strand from 1/4 inch to 7/16 inch. The lasher can be operated from the ground or parallel to the strand by a single worker.

Also available from **General Machine Products Co.** is a family of

connector products for making modular instrument, data and voice wire connections. The chief components are a special connector pressor, interchangeable dies, modular plugs, cordage and reel. For more info on either the cable lasher or connector products, call (215) 357-5500.

**Energy Control Systems** has introduced the Protector AC power-

line transient voltage suppressor for prevention and elimination of power problems and damaging effects of transients, spikes and surges. According to Energy Control Systems, the Protector is able to withstand in excess of 20,000



# Innovators Lead the Way



**Construction and Subscriber Hardware Specialist**



**SACHS®**

Sachs Communications Inc.  
30 West Service Road, Champlain, N.Y. 12919-9703  
CALL TOLL FREE 1-800-361-3685



E-Z Trench...  
fast  
and easy.



**NEW TURF SURF**

by E-Z Trench

IN ONE

**Application**

- OPENS TRENCH
- PLACES CABLE
- BACKFILLS TRENCH

**BURY UP TO 100 FT. OF CABLE IN APPROXIMATELY 10 MINUTES**

**Priced under \$1,000, TS-1000 handles jobs that previously would have taken machinery costing several thousand.**

TO ORDER OR FOR  
DISTRIBUTOR INFO CALL:  
**1-803-756-6444**

**E-Z TRENCH**

Route 3, Box 78B  
Loris, South Carolina 29569

Reader Service Number 80

transients with no deterioration or reduction in performance. For more info call (817) 483-8497.

**Fiber guide helps planning**

A Planning Guide for cable television applications will be available in May 1989, from DTI Telecom Inc. The guide discusses methods to deploy fiber technology while maintaining long-term profitability and competitiveness. The Planning Guide can be used to assist cable operators in decision-making for system architecture and technology. For additional info call (514) 845-3205.

Laser Precision Corp. has intro-

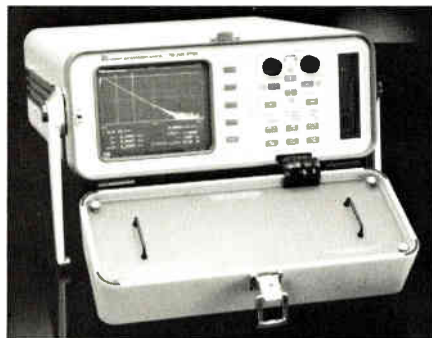

*Laser Precision Corp.'s optic time domain reflectometer, the TD-2000*



*Laser Precision Corp.'s loss test sets, the LTS-4410/4510*

duced it's eighth generation Optic Time Domain Reflectometer (OTDR), the TD-2000. Applications include both long-and short-haul fiber optic testing. The TD-2000's built-in disk drive enables the user to store all trace data on floppy disks. Features of the TD-2000 include uploading data, mapping a cable system, overlaying traces and zooming in on any point of interest and analyzing a fiber optic system on a personal computer.

Also available from Laser Precision Corp. are two Loss Test Sets (LTS), the LTS-4410/4510 for fiber optic testing. The LTS-4410 is a two-button and the LTS-4510 is a four-button hand held set which handles all aspects of fiber testing such as cable acceptance, accurate alignment of splices

and connectors, end-to-end tests of installed links and cable system performance testing. Other features include a germanium detector, AC or battery operation, four digit LCD display, eye safe-class 1 laser operation, fiber identifier option (AM-450) and tone output. For more details call (315) 797-4449.

Introduced by Ortel Corp. are the Models 1515A and 1515B, 10 and 12 GHz laser modules. Modulating microwave signals onto a 1300 nm laser coupled to a singlemode optical fiber, these modules are capable of transmissions over 20 kilometers and beyond. Both models have typical RIN values of less than -150 dB/Hz at 2 GHz. Designed for analog transmission, specifications of the 1515A/B laser modules include flat response, 50 ohm coaxial SMA input, singlemode 1300 nm optical fiber pigtail, and -40 degree to 70 degree centigrade operation. Call (818) 281-3636 for info.

**People on the move**

Wegener Communications has announced the promotions of Ned Mountain to vice president of marketing and Elias J. Livaditas to vice president of engineering. Mountain is responsible for the management of sales, marketing, order processing and customer service. Livaditas, who has been with Wegener since 1979, was responsible for the design of many of Wegener's products. He has also provided technical leadership for the company's digital and analog audio systems, subcarrier and SCPC (single-channel-per-carrier) transmission equipment and the Series

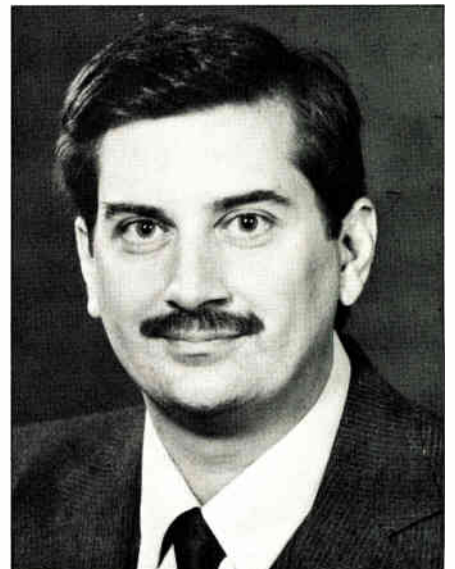

*Elias J. Livaditas*



## IN THE NEWS

1800 Receiver product family.

**Mike Kearns** has recently been named national sales manager for



*Jim Barthold*



*Kurtis Whitt*

**Lectro Products Inc.** Kearns was formerly Lectro's Eastern sales manager.

**Comm/Scope** has named **Bill Davis** to the position of district sales manager for the upper Midwest, including Iowa, Minnesota, Wisconsin, and parts of Michigan, Nebraska and North and South Dakota.

**Jerrold** has promoted **Kurtis Whitt** to sales national account manager. Whitt, who joined Jerrold in 1981, was previously account manager for Florida, Georgia and South Carolina. He will now be based in Atlanta and is responsible for Cox Cable.

Also promoted by **Jerrold** was **James Barthold** to public relations manager. Barthold will be responsible for primary contact with the trade and media concerning the activities of various Jerrold groups. Barthold, who has been with Jerrold since 1983, has served in a variety of communications functions, starting as staff writer to, most recently, senior creative writer.

In other announcements from **General Instrument**, the **VideoCipher Di-**

**vision** named **Michael K. Walker** as vice president of communications and industry relations. Walker's primary role will be to serve as an advisor to the president on industry relations and all other communications-related programs. Prior to joining GI, Walker served as vice president and group supervisor for the Los Angeles office of **Ruder Finn & Rotman**.

**Anixter Bros., Inc.** has announced the promotion of **Marlowe Taylor** to

# THE FCC IS READY.



# ARE YOU?

Does your system comply with FCC leakage regulations? Now is the time to find out. The simplest, most effective, least expensive method to test for signal leakage is CableTrac's CLASS (CATV Leakage Aerial Survey System) "flyover" service.

It's the least expensive because it uses state-of-the-art signal tracking technology developed by Dovetail Systems.

It's the most effective because it graphically identifies leakage "hot spots" going far beyond a simple pass/fail report.

It's simple because you can now test in a day what otherwise would take weeks — without disrupting the work schedule of your staff.

The CableTrac report is ready for FCC filing and gives you additional credibility with the regulators through our independent "third party" status.

CLASS service is ideal for gaining access to the areas hard to reach with a ground crew. And CLASS service is available virtually everywhere throughout North America.

Call CableTrac today for additional information. Before July 1, 1990 slips up on you.



CableTrac, Inc.  
19011 36th Ave. W. Suite A  
Lynnwood, WA 98036  
(206) 774-2100

Reader Service Number 82

See us at the NCTA, Booth #2068.

A service of Dovetail Systems and Alpha Technologies.

regional vice president, Southeast region. Taylor will manage Anixter's distribution business for the 10 service centers in the region. Formerly vice president of operations for the company's West region, Taylor joined Anixter in 1984 as operations manager of the Seattle location.

**Cable Television Laboratories Inc. (Cable Labs)** has named **Thomas F. Gillett** to vice president of business development and technology transfer. Gillett joins Cable Labs from GTE where he served as director of advanced operations testing. Gillett will be responsible for integrating the work of Cable Labs with the day-to-day business of the cable industry.

**Victor F. Palousek** has been appointed manager, cable products, for **EF Industries**. Palousek is responsible for expanding the company's repair of addressable cable television converters. Palousek previously was manager of the Victorville, Calif., plant of Anixter Manufacturing Co.

**Sarah J. Crisp** has been promoted to publicity coordinator for the industry communications department of the **National Cable Television Associa-**

tion on Optical Fiber Communication (OFC '89). The scientists, members of Corning's research, development and engineering division, led the team that in 1970 developed a process for fabricating the first optical fiber suitable for telecommunications. Both scientists were selected to fellow grade by the Lasers and Electro-Optics Society of IEEE for unusual distinction in the profession.

**Other happenings**

**Blonder-Tongue Laboratories, Inc.** has been sold to a closely held group which intends to continue to operate and develop the business from the New Jersey headquarters. Retaining the Blonder-Tongue name and rights, the new organization will not alter the company's format. The investment group has named **James A. Luksch** as president and **Robert J. Palle Jr.** as executive vice president.

**C-COR Electronics Inc.** has announced the decision to build a new manufacturing facility in the State College/Bellefonte, Pa. area. The new plant will be 40,000 to 50,000 square feet and have the capacity for 300

Hickory and Newton, N.C., operations into one central facility located in Hickory. The 84,000 square-foot facility currently houses 85 employees.

In a joint announcement with **Channel Master**, the **VideoCipher Division** also disclosed the VideoCipher Module Service Dealer (VMSD) program has been expanded to include field repairs of satellite equipment containing Channel Master manufactured VideoCipher II modules.

Continental Cablevision has ordered approximately \$5 million worth of Tocom 5503-VIP baseband converters from the **Jerrold** division of General Instrument. The converters will be used for upgrading and expanding the subscriber base of Continental's Los Angeles Metro system.

**Jerrold** has also announced the creation of the "Jerrold Seminar Series." Each seminar covers cable television technology but focuses on a specific audience need. Included in the series are: Technical Seminars, Cable Insights (cosponsored by CTAM), Future Technologies, Fiber Optics, Addressable Users Group, CTAM General Manager Achievement Series and Broadband LAN Seminars. For details call (215) 674-4800.

**Cable Labs** and chief technical executives from 11 cable MSOs met in Stamford, Conn. for the first meeting of Cable Lab's Technical Advisory Committee's Fiber Optic Subcommittee recently. The subcommittee is charged with monitoring, evaluating and reporting on developments in fiber optic video transmission systems. Several in attendance agreed the meeting represented and confirmed the industry's commitment to the use of fiber optics. Call (617) 576-5754 for info.

**Tele-Communications Inc.'s** Senior Vice President John Sie has called for a national effort to "leapfrog" foreign HDTV competition by setting a national goal to develop processed digital television distribution techniques by 2000. Sie based his comments on economics, noting that there was no rational reason to discard present NTSC equipment for HDTV gear when digital television is the true wave of the future.

Finally, on a related subject, **NHK's** MUSE advanced television format was tested in Media General and Jones Intercable systems near Washington, D.C. last month. The major purpose of the demonstration was to show that a high-quality, satellite-delivered HDTV picture can be provided by traditional coaxial means, according to NCTA.

—Kathy Berlin

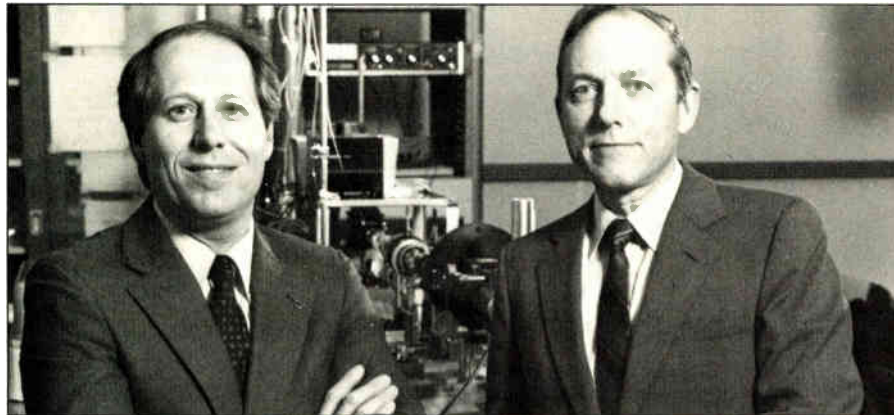

*Dr. Donald C. Keck (left) and Dr. Robert D. Maurer were honored at the Conference on Optical Fiber Communication (OFC '89). The two scientists led the team that in 1970 developed a process for fabricating the first optical fiber suitable for telecommunications.*

**tion.** Crisp will help to coordinate three annual television critics tours and manage press facilities for both the ACE Awards and the NCTA's annual convention.

**ViaSat Technology Co.** has announced the appointment of **Donald V. Anderson** as director of engineering, in charge of product design and development. Prior to joining ViaSat Technology, Anderson was digital processor design group leader at Emerson Electric, Electronics and Space Div.

**Dr. Donald C. Keck** and **Dr. Robert D. Maurer** were honored at the Confer-

manufacturing employees. The new facility is to allow room for expansion in all departments. When completed, the plant will house all of C-COR's State College manufacturing activities.

General Instrument's **VideoCipher Division** announced that the introductory price of the VideoCipher II-Plus module will be the same as the current price of the VideoCipher II module. VideoCipher II-Plus is an enhanced version of the original descrambler technology for the home satellite TV consumer. The VideoCipher Division also announced the consolidation of the



# FAST FIELD SECURITY FOR YOUR CABLE TV PEDESTAL

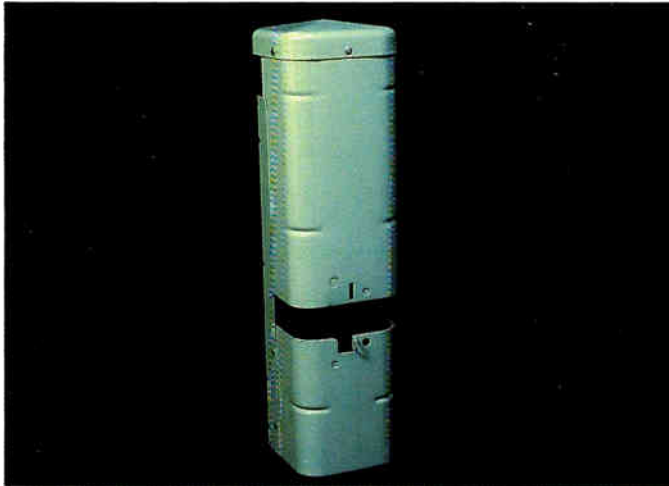

Pedestal cover with knock out in place.

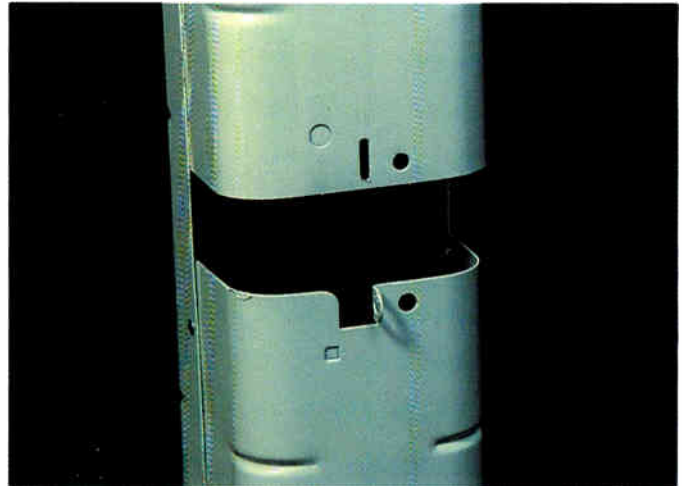

Knock out is easily removed with hammer and ordinary screwdriver.

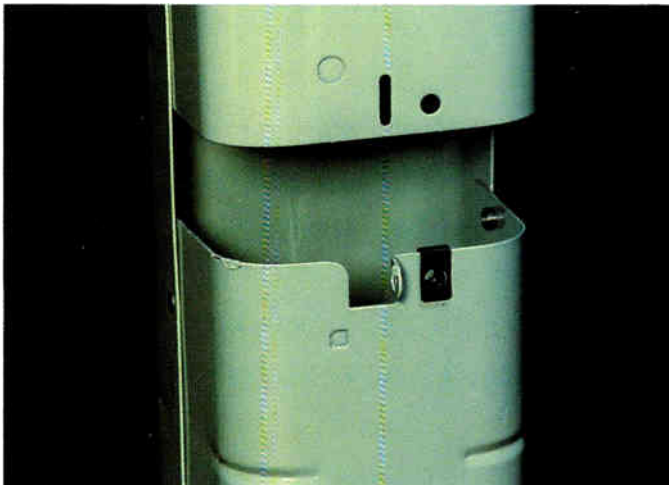

Locking clip fits over pedestal in seconds.



Star Lock is tightened and removed only with special screwdriver type key for maximum security.



Only Reliable pedestals come with factory-provided knock outs for installing **Diversified Control Systems Star Locks.**

A small but important feature... because it provides maximum security for cable TV pedestals or apartment boxes

fast and easy right in the field.

Hasp broken or missing? No problem. Diversified's Star Locks are designed to deliver a secure closure without using the hasp.

It's a great combination: Star Locks and Reliable Electric, the best-selling pedestals in the industry. And you can get them both from one trusted source: Anixter Cable TV.

**RELIABLE**

RELIANCE COMM/TEC

**ANIXTER**  
CABLE TV®

**WEST-ANAHEIM:** (714) 779-0500, (800) 854-0443; **DENVER:** (303) 373-9200, (800) 841-1531; **SEATTLE:** (206) 251-6760, (800) 426-7665; **MIDWEST-CHICAGO:** (312) 364-7000, (800) 544-5368; **CLEVELAND:** (216) 526-0919, (800) 321-8068; **DALLAS:** (214) 446-7337, (800) 231-5006; **IRON MOUNTAIN, MI:** (906) 774-4111, (800) 624-8358; **SKOKIE, IL HDOTRS:** (312) 677-2600; **EAST-ATLANTA:** (404) 995-5110, (800) 241-5790; **LONG ISLAND, NY:** (516) 293-7788, (800) 645-9510; **NEW JERSEY:** (201) 328-0980, (800) 631-9603; **TAMPA:** (813) 626-7115, (800) 282-9164; **CANADA-CALGARY:** (403) 250-9646; **MONTREAL:** (514) 636-3636; **TORONTO:** (416) 625-5110; **VANCOUVER:** (604) 321-5885

In an emergency, weekends and holidays or after 5 P.M. call toll free 1 (800) 323-8166.  
**CORPORATE OFFICES, ANIXTER CABLE TV, INC.,** 4711 Golf Road, Skokie, IL 60076, (312) 677-2600

© 1989 ANIXTER CABLE-TV

# The Future Is Here!



## The ANIXTER Fiber Optic Laser Link AM CATV System

AT&T and Anixter Cable-TV have joined forces to bring you — *today* — the most exciting technological advancement in the cable-TV industry. And, we're proud to say it's the *only* system that is truly "Made in U.S.A."

It's Anixter's Fiber Optic Laser Link AM CATV System — a major breakthrough for cable TV in the transmission of multiple AM analog television channels over long distances. Following extensive, highly successful field tests, initial installations of the Laser Link System will be made

*this year* by many MSO's. Major features and benefits include:

- Easy installation and maintenance
- Compatible with existing CATV networks
- Low start-up costs
- Reduced maintenance costs
- Easy network upgrades
- Improved signal quality and reliability



For more information, call the Anixter office in your area.

See us at the NCTA Show, Booth #1869

# ANIXTER CABLE TV

CORPORATE HEADQUARTERS: ANIXTER CABLE-TV, 4711 Golf Road, Skokie, IL 60076 (312) 677-2600 — Telex 289464

Reader Service Number 81

©1989 Anixter Cable TV