

# CEED<sup>TM</sup>

Communications Engineering Digest/The Magazine of Broadband Technology

May 1981

- 400 MHz Headend Analysis
- Dollars-per-dB Program

FA4T-8105MCC52205-21.807  
FRED E MCCORMACK  
FOX 5221 ST UNIT IV  
FARGO ND 58105

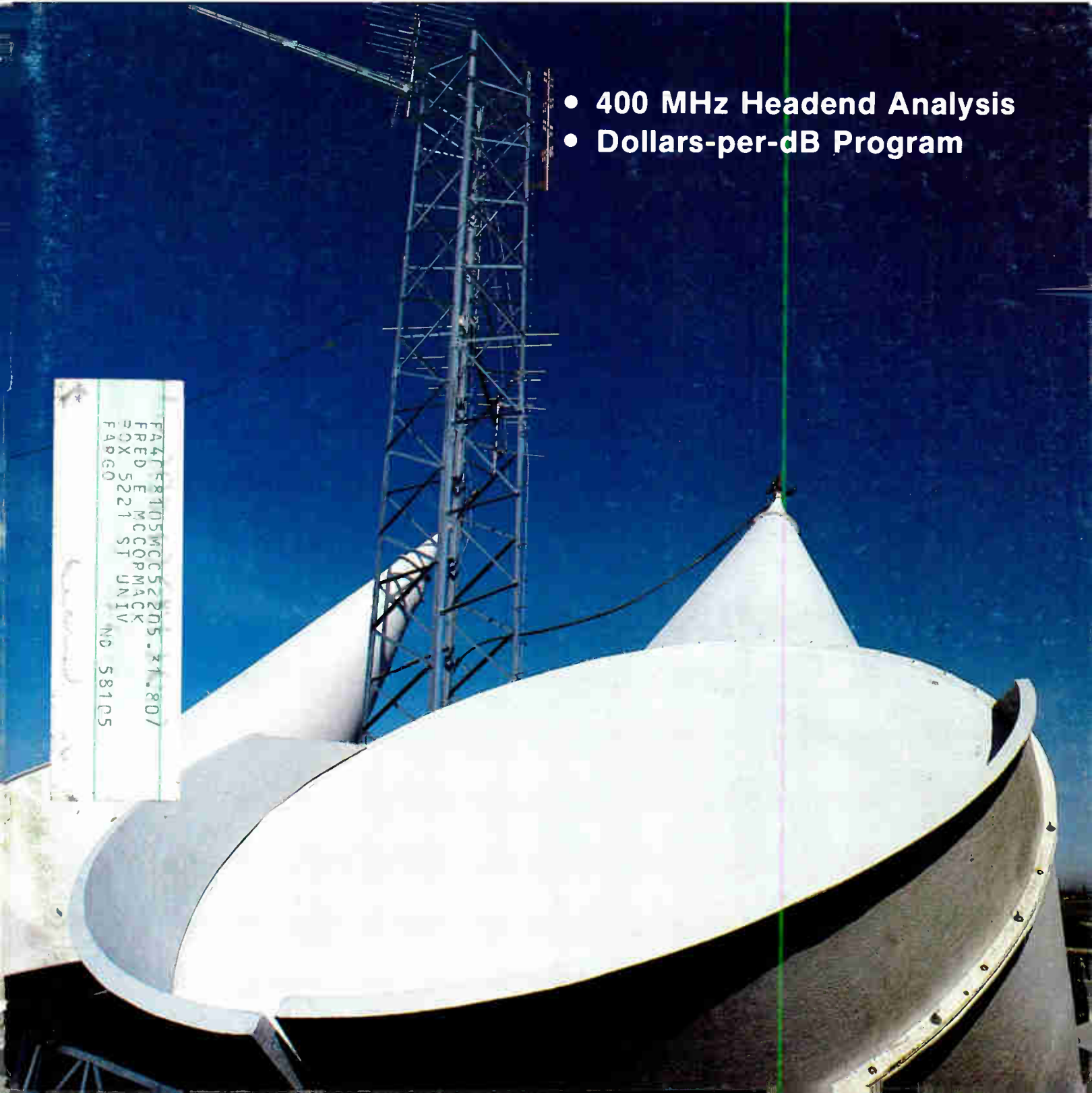

# Oak TotalControl is NOW



## The first and only commercially proven addressable CATV system.

If now is when you're interested in a new addressable system or a rebuild, consider that there's still only one commercially proven addressable system that's available – Oak TotalControl®. With tens of thousands of operating TotalControl terminals, it's a proven profit-builder – not an experiment. The same technology has also been proven with over half a million operating STV terminals.

That's a record no one else even comes close to.

TotalControl is a true turn-key system offering second generation modular software, unequalled in versatility. TotalControl delivers up to 16 tiers, 56 channels (112 channels on dual-trunk systems), pay-per-view and remote disconnect, and offers infrared remote.

For a free TotalControl package, including an actual system cost analysis, call our locator operator toll-free at 800-323-6556 (in Illinois, 800-942-6345) and ask for the CATV information desk.

**OAK**  
Communications  
Inc. | CATV  
Division

Crystal Lake, Illinois, 60014 Telephone 815 459 5000 FAX 910 634 3353

**AM** puts it all together

Engineering

Construction

**AM Cable TV Industries, Inc.**

Equipment

Design

**For FULL SERVICE...**

- Make-ready survey
- Design: strand & electronics
- CATV equipment
- Field engineering
- Quality construction
- Full turnkey service

**call on**



**AM CABLE TV INDUSTRIES, INC.**

P.O. Box 505, Quakertown, PA 18951

*Formerly AM Communications Corporation, AM Electronics Corporation and Courier-Hooks Corporation*

**TOLL FREE: (800) 523-6742 OR 6743**

**IN PA: CALL COLLECT (215) 538-2750**

# INCOMPARABLE

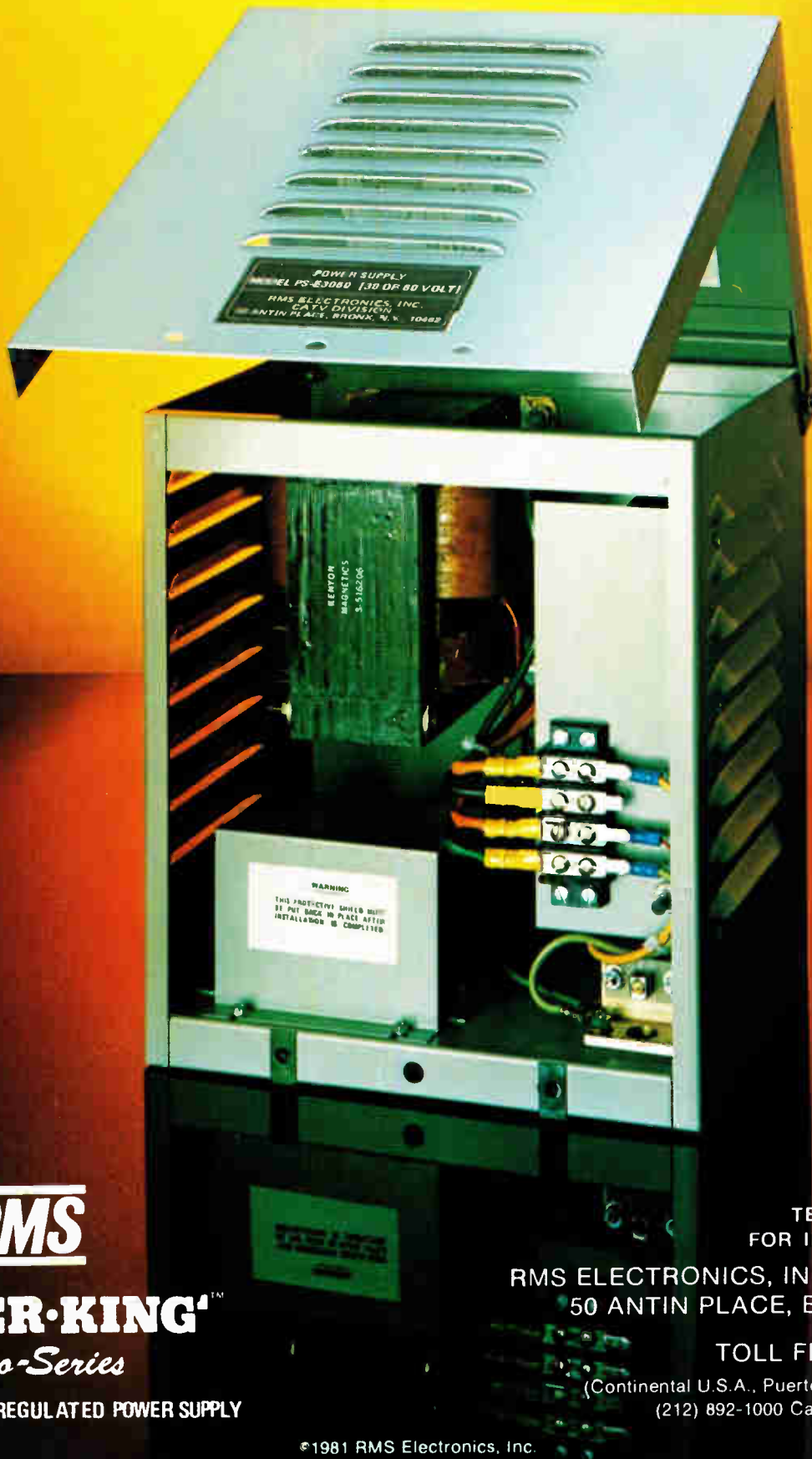

**RMS**

**'POWER-KING'**<sup>TM</sup>

*Econo-Series*

MODEL PSE-30/60 AC REGULATED POWER SUPPLY

TELEPHONE OR WRITE  
FOR IMMEDIATE DELIVERY

RMS ELECTRONICS, INC./CATV DIVISION  
50 ANTIN PLACE, BRONX, N.Y., 10462

TOLL FREE (800) 223-8312

(Continental U.S.A., Puerto Rico, U.S. Virgin Islands)  
(212) 892-1000 Call Collect (New York State)

©1981 RMS Electronics, Inc.

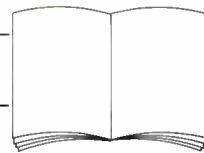

### Techscope 7

Comsat finds a friend in the Commerce Department.

### Seminars 8

Regional cable television association meetings, SCTE technical workshops and other industry events.

### Editorial 13

Pat Gushman discusses the FCC's recent action on direct broadcast satellites.

### Communication News 15

Both houses of Congress have introduced legislation to gain stronger control over the FCC and establish a schedule of fees for FCC services.

### 400 MHz: Not As Easy As $A \pm B \pm C$ 26

An analysis of the advantages, disadvantages and costs of using a harmonically-related carrier headend in 52-channel systems. The article also discusses the possibilities of interference with VHF channels and aeronautical frequencies in 400 MHz systems.



### Comparing dBs and Dollars With a Hand-Held Calculator 35

A calculator program for evaluating earth station components on a dB/per dollar basis.



### Ad Index 39

### Coaxial Cable: The Connecting Link 45

CED's series of test equipment articles concludes with an overview of the properties of cable and helpful hints on

avoiding ghosting and other cable-related service problems.

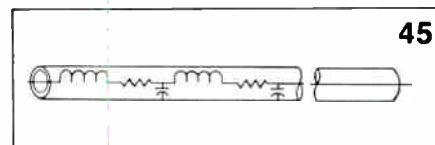

### Watching Out For Poorly Plated Passives 53

A look at installation materials that did not survive salt spray testing.

### Out of Sync 58

The function of "diplex filters" and answers to other technical questions.

### Intermod 61

CED's Glenn Chambers ponders the question: Do you need an EE to call yourself an engineer?

### International News 65

Canada authorizes fiber optics communications experiments in rural areas.

### Product News 69

### People News 77

### Classifieds 79

### In Orbit 82



### About the Cover

Conical horn antennas are used at ATC's Littleton, Colorado, system because of terrestrial microwave interference in the area. The 400 MHz Littleton system utilizes a harmonically-related carrier headend. The photo was taken by CED's photo editor, Bill Fletcher.

# In CATV You can get most anything you need from us.

## Including the truth about what you can't get.

Our stock of CATV equipment is one of the largest anywhere.

It includes antennas, headends, and earth stations at one extreme. Electrical tape, crimpers, and staplers at the other.

The things we carry are the best and the latest we can find. With names you and we know as reputable and reliable.

We ship from stock, the day you order. But sometimes, in spite of our best efforts, we just don't have the item you want in stock.

We don't deal in false promises. We'll tell you we can't ship. And suggest another source if we know one.

Some things you can always get from us:

- No minimum billing. No minimum order.

You won't be charged \$15 for a \$5 item when you buy it from us. And you won't have to buy a lot of other things you don't want or need.

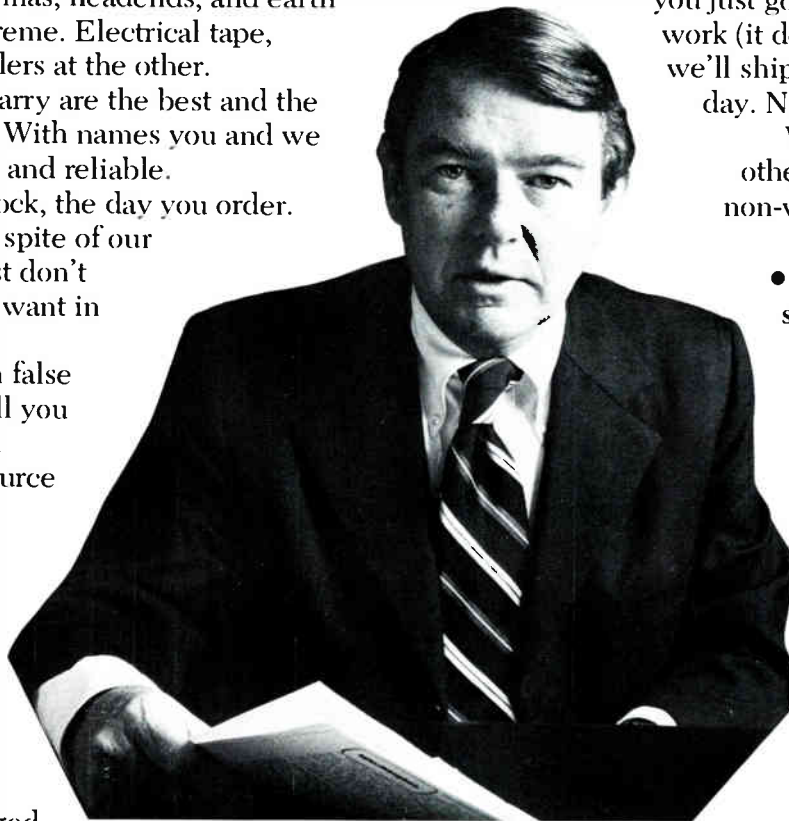

- An instant, hassle-free replacement policy. Which means that, when you plug in something you just got from us, and it doesn't work (it does happen) call us, and we'll ship you a replacement that day. No waiting, no quibbling.

We don't—like so many others—tell you to ship the non-working unit back to the manufacturer.

- CATV's best customer service. Experts you can consult with any time on our toll-free line.

Get simple and straight answers to your questions. Or comprehensive recommendations concerning sophisticated subjects. Like antenna systems design, and system layouts. Custom-designed headends. Free always. Call us now for our complete

catalog. The phone call and the catalog are free. No obligation when you talk to us, ever.

Toll-free 800-523-5947

In Pennsylvania 800-492-2512

**Toner**  
cable equipment, inc.

969 horsham road, horsham, PA 19044

See Us At The NCTA Show—Booth #401

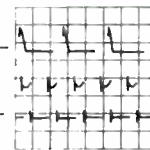

## Comsat's Powerful Friend

It appears as though Comsat has discovered some powerful friends in its quest to receive FCC approval of its DBS plans. The Department of Commerce filed with the commission asking for "prompt action" to authorize the company's plans. Comsat, of course, filed last December asking the FCC to approve the beginning stages of a \$600 million venture into DBS. Comsat's new friend told the FCC that early authorization was imperative so Comsat could compete with other television technologies. "For DBS to compete effectively," the filing read, "it must be operational by the early 1980s." Beyond competing with domestic services for the public's viewing habits, the Department also said that other nations are starting to get the jump on the United States regarding DBS. Prompt approval of Comsat's plans would improve the U.S. position in telecommunications around the world, the filing added.

## A Grave Filing

Obsolescence occurs all too quickly for many technical products. The pace, however, can be ever quicker for FCC proceedings. Recently, the FCC decided to terminate an inquiry on technical changes in television broadcasting standards. The proceeding was initiated in 1969 to facilitate international exchange of programs. In particular, it would have standardized the specific lines in the vertical blanking interval that are used for transmitting test signals during international broadcasts. However, before the commission could act on the proceeding, subsequent proceedings were begun that overlapped the issue. In fact, since 1974, the same line of the blanking interval that was used routinely on an international basis for test signals has been available in this country. Stating that there would be "no evident benefit" from continuing the attempt for compatibility changes, the FCC quietly put the 1969 proceeding to rest.

## Aeronautical Opus

At last there is a revised list of aeronautical navigation frequencies that conflict with or are near cable television frequencies. The National Technical Information Service has compiled a "significantly more complete" publication of frequencies utilized by the Federal Aviation Administration for air navigation and air-to-ground communications throughout the United States. Copies of the publication can be obtained by writing the NTIS at: 5285 Port Royal Road, Springfield, Virginia 22161. Ask for publication number PB81-923902, *Aeronautical Frequency Assignments near Cable Television Carrier Frequencies*, Volume 5, Number 2.

## Unexplained Switch

There were some unusual incidents surrounding the television coverage of the Senate Rules Committee hearings last week. Since the topic was allowing television cameras into the Senate chambers, the hearings became a media event covered by both the major broadcast networks and C-SPAN. As preparation for the hearings progressed, the Senate Radio and Television Gallery announced that a single camera would be used to record the testimony. C-SPAN protested this decision for quite valid reasons: the networks could get by with lid reasons: the networks could get by with a single camera since they were only interested in flashing 45-second

clips on the evening news, but this would not serve the needs of C-SPAN. The cable network needed a second camera so the entire proceedings could be recorded in a manner suitable for airing. C-SPAN protested to the Rules Committee which eventually gave them permission to set up a two-camera system. However, the afternoon before the hearings began, C-SPAN was notified that ABC would be running a two-camera system and the cable network would have to plug into the network pool to tape the proceedings. To make matters worse, the C-SPAN crew (which had no choice but to submit to the wishes of the Rules Committee) was less-than-pleased with the technical quality of the ABC feed. At week's end, no explanation for the switch had been given.

## Cutting Off Low-Power Applications

The Federal Communications Commission has voted to discontinue accepting new applications for low-power television stations. Responding to "insufficient staff and computer capability," the FCC approved the action, effective immediately. Nearly 5,000 applications had been filed in response to the February 17 and March 31 cut-off dates. This glut of filings has caused a severe backlog at the commission and the action was taken "to permit the staff to catch up" in processing the stacks of applications. The commission stated that it is not imposing a moratorium on processing the applications received before the deadlines. However, at least for the moment, no new applications will be accepted.

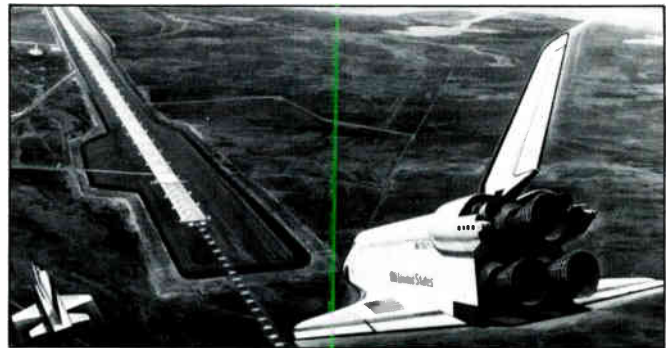

## Step Right Up

The successful maiden voyage of the space shuttle *Columbia* will have a pronounced effect on the cable television industry. The innovative technique of re-using the vehicle, as well as the lift-off rockets, will cause the price of launching a satellite to plummet almost as fast as the *Columbia's* re-entry velocity. When the use of an expendable launch vehicle to lift a satellite into orbit was the standard mode (it seems like only yesterday), the cost of launching the bird ran from \$1,600 a pound to \$7,500 a pound. A NASA spokesman tells us that a standard launch using the space shuttle will cost around \$438 per pound. By 1985, NASA intends to have four shuttles in operation. The process for launching a communications bird will be as follows: the satellite is loaded into the cargo area of the shuttle; the shuttle is launched into orbit and then the satellite is dropped off at the shuttle's peak orbit of not more than 600 miles from earth. Next, an inertial upper stage booster rocket will hurl the satellite up to the geosynchronous arc. Already RCA Americom, Western Union, Southern Pacific Communications and Hughes Aircraft are lining up to reserve space for their birds.



## MAY

**4-8:** The **Community Antenna Television Association** will present a cable television technical training seminar at the Paramount Heathman Hotel in Portland, Oregon. Contact the CATA at (305) 562-7847.

**5-7:** A **Jerrold** technical seminar will be held in Portland, Oregon. Contact Len Ecker, (215) 674-4800.

**11-12:** The **Society of Cable Television Engineers** will sponsor "System Test Requirements" and "System Preventive Maintenance" seminars at the Hilton Airport Inn, Kansas City, Missouri. Contact SCTE at (202) 293-7841.

**12-13:** A conference on "Local Networks—Business and User Strategies for the '80s" is being sponsored by **TeleStrategies, Inc.** at the Hyatt Regency Hotel in Washington, D.C. Contact TeleStrategies, (703) 734-7050.

**13-15:** **Integrated Computer Systems, Inc.**, is holding a workshop on "Fiber Optics Communications Systems" in Washington, D.C. Contact Ruth Dordick, (800) 421-8166; (213) 450-2060.

**15-16:** The fourth in a continuing series of **Iowa Technical Seminars**, sponsored by Cable Communications of Iowa and Heritage Communications, Inc., will be held in Newton, Iowa. The topic will be "Pay TV Security, Converters and TV Set Interface." Contact Helen Clymer, (515) 245-7587.

**20-22:** **Infomart** and **Online** are sponsoring "Videotex '81," a seminar on videotex communications at the Royal York Hotel in Toronto, Ontario. Contact the firm at (416) 598-1981.

**20-22:** The 7th annual Los Angeles Professional Videoshow will be held at the Los Angeles Convention Center, sponsored by "**Educational & Industrial Television**" magazine. Contact Ellen Parker, (203) 743-2120.

**22-23:** The **National Federation of Local Cable Programmers/Southwestern Region** is sponsoring a two-day seminar entitled "After Franchising" at the Texas Christian University, Fort Worth, Texas. Contact Ed Deane, (214) 521-3111.

**26-28:** **Information Gatekeepers, Inc.**, is sponsoring "Electronic-Office '81" at the Commonwealth Pier Exhibition Hall, Boston, Massachusetts. Contact Michael A. O'Bryant, (617) 739-2022.

**29-June 1:** The **National Cable Television Association** is holding its annual convention at the Los Angeles Convention Center, Los Angeles, California. Contact Dan Dobsin, (202) 463-7905.

## JUNE

**1-5:** The **Community Antenna Television Association** is holding a cable television technical training seminar at the George Washington Motor Lodge-East in Philadelphia, Pennsylvania. Contact the CATA at (305) 562-7847.

**9-11:** A **Jerrold** technical seminar will be held in San Francisco, California. Contact Len Ecker, (215) 674-4800.

**9-11:** The International Marketing Center of the U.S. Department of Commerce, Paris, France, is sponsoring an exhibition and seminar on U.S. fiber optics, "**Fiber Optique-'81.**" Contact Ellen M. Bond, (617) 739-2022.

**14-16:** **Montana Cable Television Association** will hold its annual meeting at the Sheraton Hotel in Billings, Montana. Contact Bob Briney, (406) 586-1837.

**14-17:** The **Institute of Electrical and Electronic Engineers** is holding its 1981 International Conference on Communications at the Hilton Hotel in Denver, Colorado. Contact Bob Skelton, (303) 779-0600.

**15-16:** The National Endowment for the Arts and Temple University are supporting a conference entitled "**Cable Television and the Independent Producer**" to be held at the university in Philadelphia, Pennsylvania. Contact Professor Alan Bloom, (215) 787-1873.

**16:** Showtime and Wometco Cable TV will host a dinner meeting of the **Atlanta Cable Club** at the Atlanta Stadium Club, Atlanta, Georgia. Contact Marian McConnell, (404) 898-8500.

**16-18:** **Nepcon East '81** will focus on the East Coast electronics manufacturing industry and take place at the New York Coliseum, New York, New York. Contact Industrial & Scientific Conference Management, Inc., (312) 263-4866.

**22-26:** **Hughes Aircraft Company's** microwave communications products has scheduled a technical seminar on its AML local distribution microwave equipment at the firm's Torrance, California, facility. Contact Seminar Registrar, (213) 517-6100.

**23-24:** A **Blonder-Tongue** MATV/CATV technical seminar will be held in Baltimore, Maryland, in conjunction with LCA Sales, Inc. Contact Glenn Stawicki, (201) 679-4000.

**23-25:** A **Jerrold** technical seminar will be held at the Best Western Arena Motor Inn in South Williamsport, Pennsylvania. Contact Len Ecker, (215) 674-4800.

**25-26:** The **New York State Commission on Cable Television** will hold its "Seventh Annual Northeast Cable Television Technical Seminar" at the Empire State Plaza Convention Center in Albany, New York. Contact Robert L. Levy, (518) 474-1324.

**28-30:** A second workshop on "How to Video-Teleconference Successfully," sponsored by the **Public Service Satellite Consortium**, will be held in Denver, Colorado. Contact PSSC, (202) 331-1154.

## JULY

**7-9:** A **Jerrold** technical seminar will be held in Madison, Wisconsin. Contact Len Ecker, (215) 674-4800.

**9:** The **National Federation of Local Cable Programmers** is sponsoring a pre-convention seminar for access and program directors at the Atlanta Biltmore Hotel, Atlanta, Georgia. Contact Cindy Kuper, (404) 523-1333.

**10-12:** The **National Federation of Local Cable Programmers** is holding its fourth annual convention at the Atlanta Biltmore Hotel in Atlanta, Georgia. Contact Cindy Kuper, (404) 523-1333.

**12-15:** The 13th annual **New England Cable Television Association** convention and exhibition will be held at Dunfey Hyannis Hotel, Hyannis, Massachusetts. Contact the association, (603) 224-3373.

**15-18:** The **Florida Cable Television Association** annual convention will be held at the Lago Mar Resort in Fort Lauderdale, Florida. Contact Convention Chairman James L. Cooper, (305) 527-6620.

**21-25:** A **Jerrold** technical seminar will be held in Philadelphia, Pennsylvania. Contact Len Ecker, (215) 674-4800.

**27-28:** The **Society of Cable Television Engineers** will sponsor a "System Preventive Maintenance" seminar at the Dutch Inn in Orlando, Florida. Contact the SCTE at (202) 293-7841.

## AUGUST

**2-4:** The **Michigan Cable Television Association's** annual convention will be held at the Hyatt Regency in Dearborn, Michigan. Contact Mike Welch, (312) 693-9800.

**4-6:** A **Jerrold** technical seminar will be held in Denver, Colorado. Contact Len Ecker, (215) 674-4800.





## DEPENDABLE CONVERTERS FROM THE PEOPLE WHO MADE TWO-WAY INTERACTIVE A REALITY!

In day-to-day CATV operations, large system or small, the cheapest converter is seldom the best buy. For overall cost effectiveness you want converters that promise more than great laboratory specs — you want converters that work everyday...under the worst conditions.

Converters that are simple...simple enough for subscribers to install themselves.

Converters that are ready to grow with an expanding system ... all the way to 400 MHz. Converters that are so reliable you can cut down on maintenance costs.

Pioneer's converters guarantee you'll get all these features and more. From the 7 and 14 channel BC-1000 and BC-1100 block converters to the 36 chan-

nel BC-2000 converter, all have hidden advantages from the knowledge we've gained with our two-way, interactive experience. Our BC-2000 converter has a buffer amplifier to reduce spurious signals and SAW filter to eliminate adjacent channel interference.

So, from our simplest converter to the most complex interactive terminal, Pioneer equipment does the job it's been designed to do — whether it's expanded channel selection or filtering out unwanted interference.

That's why Pioneer's converters have received so many favorable comments from MSO's. Because they know dependable converters aren't a luxury.

After all, Pioneer promises not to make the cheapest converters, only the best.

 **PIONEER®**

PIONEER COMMUNICATIONS OF AMERICA

3518 Riverside Drive Columbus, Ohio 43221 (614) 451-7694

© 1981, PIONEER COMMUNICATIONS OF AMERICA

# Power-Passing Splitters, Directional Couplers Power Inserters & Equalizers 5 to 400 MHz



Housing  
Dimensions  
4.80" L  
x 4.50" W  
x 2.25" H

#### Features:

**Zinc die-cast housing** with excellent weather-resistant properties. **Stainless-steel inserts** prevent thread damage to cable entry ports and provide a shoulder for heat-shrink tubing. **Environmental seal and RFI/EMI integrity** provided by a Duosil gasket. **Corrosion-resistant chromate** and thermo-setting acrylic finish meets or exceeds military spec No. 5507 and the 96 hour, 5% salt-spray test. **Captive, stainless-steel bolts** on cover plate eliminate bolt-loss and prevent bolt rusting.

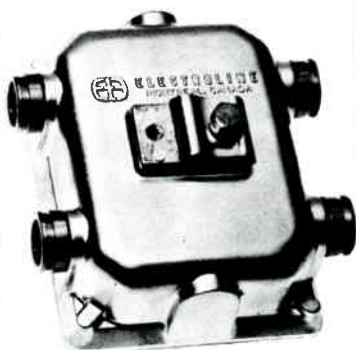

Three-Way Splitter  
Three-Way  
Directional Coupler



## ELECTROLINE Television Equipment Inc.

8750, 8th Avenue, St-Michel  
Montreal, Que. H1Z 2W4

or phone **collect**  
(514) 725-2471

Representatives across  
Canada and the U.S.A.

- TAPS
- FILTERS
- COUPLERS
- SPLITTERS
- SPECIAL AMPLIFIERS
- SWITCH-TRANSFORMERS

**17:** Southmedia Company and Scientific-Atlanta will host a dinner meeting of the **Atlanta Cable Club** at the Atlanta Stadium Club, Atlanta, Georgia. Contact Marian McConnell, (404) 898-8500.

**18-20:** The **Institute of Electrical and Electronics Engineers'** 1981 International Symposium on Electromagnetic Compatibility will be held at the University of Colorado, Boulder, Colorado. Contact Charlotte Tyson, (303) 447-5072.

**19-21:** The 3rd annual Satellite Communications Users Conference, sponsored by "**Satellite Communications**" magazine, will be held at the Regency Hotel, Denver, Colorado. Contact *Satellite Communications*, (303) 988-4670.

**19-23:** The **Rocky Mountain Cable Television Association** is holding its annual meeting at the Ramada Snowking Inn, Jackson Hole, Wyoming. Contact Al Carola, (307) 362-3773.

**20-22:** The **Southern Cable Television Association** convention and trade show, the "Southern Show," will be held at the Georgia World Congress Center, Atlanta, Georgia. Contact the group at (404) 237-8228

**31-September 4:** The **Community Antenna Television Association** is sponsoring a technical training seminar on system distribution, problems, failures, tests and measurements at the Regency Plaza Hotel, Minneapolis, Minnesota. Contact the CATA Engineering Office, (305) 562-7847.

### SEPTEMBER

**1-3:** A **Jerrold** technical seminar will be held in Quebec, Canada. Contact Len Ecker, (215) 674-4800.

**1-3:** **Information Gatekeepers, Inc.**, is holding its Fiber Optics Exposition '81 West at the Hyatt Regency in San Francisco, California. Contact the firm at (617) 739-2022.

**9-11:** The **New Mexico Cable Television Association** annual convention will be held at the Roswell Inn, Roswell, New Mexico. Contact Oscar Davis, (505) 538-3701

**14-15:** The **Society of Cable Television Engineers** will offer a seminar on "Cable Plant Construction" at the Hyatt Airport Hotel in Los Angeles, California. Contact the SCTE at (202) 293-7841.

**23-25:** The **Public Service Satellite Consortium** will hold its sixth annual Conference for Satellite Communications Users at the Washington Hilton Hotel in Washington, D.C. Contact Polly Reed Rash, (202) 331-1154.

**28-30:** **Catel-Expo**, the CATV exposition arm of Crimpers Promotions, Inc., will sponsor "Programming Sources '81," a programming exposition and conference, at the Las Vegas Hilton Convention Center. Contact Catel-Expo at 127 North Broadway, Hicksville, New York 11801.

**29-October 1:** **COMSEC '81**, the International Communications Security Conference and Exposition at Chicago's Hyatt Regency O'Hare. Contact Michael A. O'Bryant, (617) 739-2022.

**30-October 2:** The **Mid-America Cable Television Association** has made plans to hold its 24th annual meeting and show at the Hyatt Regency Kansas City, Kansas City, Missouri. Contact Rob Marshall, (913) 887-6119.

### OCTOBER

**5-9:** A **Community Antenna Television Association**-sponsored technical training seminar on system distribution, problems, failures, tests and measurements will be held at the Howard Johnsons, Columbus, Ohio. Contact the CATA Engineering Office, (305) 562-7847.

### NOVEMBER

**2-6:** The **Community Antenna Television Association** is sponsoring a technical training seminar on system distribution, problems, failures, tests and measurements at the Harbor Motor Inn, West Sacramento, California. Contact the CATA Engineering Office, (305) 562-7847.

# We found two more ways of improving our patented PIII coax.

See us at the NCTA Show—Booth #300



Every reel 100% sweep-tested.

We've added two new sizes. Now the top of the line is a full line. You have your choice of 1/2", 5/8", 3/4", 7/8" and 1" cable. The 5/8" and 7/8" are new. ■ Comm/Scope PIII still offers 50% more bandwidth (5-450 MHz) with a minimum return loss of 30 db throughout the range. Stable attenuation is assured with outstanding low-loss characteristics. ■ So now you have a full range of PIII sizes; you have PIII application-proved reliability; and, as always, Comm/Scope service and quality. ■ Finding more ways to offer you the finest coaxial cable on the market at competitive prices is what being the industry leader is all about. Comm/Scope, A M/A-COM Company, Box 199, Catawba, NC 28609, (704) 241-3142.

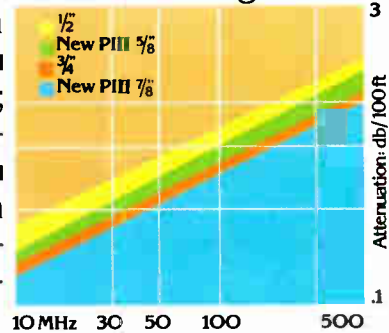

# CATV & MATV devices and accessories we got 'em!



From splitters, directional taps, amplifiers, couplers, connectors, adapters, terminators and switches, to jumper cables, outlets, wall plates, matching transformers and antennas. We got 'em. And delivery is off-the-shelf.

Want our complete catalog? Write BP Electronics, 855 Conklin Road, Farmingdale, New York 11735. Or for prompt action call, 516 752-0313.

**PRESIDENT** Robert Titsch  
**EXECUTIVE VICE PRESIDENT** Paul FitzPatrick  
**VICE PRESIDENT, WASHINGTON BUREAU, AND PUBLISHER** Pat Gushman  
**VICE PRESIDENT, NEW YORK BUREAU** Barbara J. Ruger  
**VICE PRESIDENT** Judy Lockwood  
**CONTROLLER** Michael Borer  
**CORPORATE COUNSEL** Gary Witt

**EDITORIAL OFFICES: Washington, D.C.:** **Publisher,** Pat Gushman; **Managing Editor,** David Price  
**Denver: Editorial Director,** Michael McCready, **Technical Editor,** Glenn Chambers; **Associate Managing Editor,** Brian Huggins; **Assistant Editors:** Wayne H. Lasley, Julie Perrin  
**New York: Associate Publisher,** Martin Laven; **Assistant Editors:** Simon Applebaum, Susan Spillman  
**Atlanta: Correspondent,** Boyd Lewis

**PRODUCTION: Production Director,** Joyce Hemmen

**ART: Art Director,** Sharon Lasley; **Assistant Art Director,** Brad Hamilton; **Artists:** Cynthia B. Carey, Earl V. DeWald, Barbara Emmons, Diana Graham, Rich Johnson, Robert Lesser, Kent Osborn, Carol Rush; **Typographers:** Sandra Guzman, Fred Karstens, Joyce Smith; **Photo Editor:** Bill Fletcher

**ADVERTISING OFFICES: Denver: Vice President, Sales,** Paul Levine; **Account Executives:** Lawrence P. Dameron III, Cathy Lynn Wilson; **Classified Sales and Special Services,** Suzanne Sparrow; **Customer Service,** Paula Nelson; **Traffic Manager,** Barbara Coit  
**New York: Regional Sales Manager,** Sherwood S. Sumner  
**West Coast: Regional Sales Manager,** Rosemary Neely

**MARKETING: Marketing Coordinator,** Julie M. Cotter

**CIRCULATION: Circulation Manager,** Mindy Anderson; **Assistant Circulation Manager,** Patricia M. Spall

**CORPORATE OFFICES: Director of Purchasing,** Michael Gumb; **Director of Finance,** Christopher Johnston

**OFFICES: Denver,** Titsch Publishing, Inc., 2500 Curtis Street, Denver, Colorado 80205 - or - P.O. Box 5400 TA, Denver, Colorado 80217, (303) 573-1433; **Washington Bureau,** 3800 N. Fairfax Dr., Arlington, Virginia 22203, (703) 522-3888; **New York Bureau,** 75 East 55th Street, Suite 404, New York, New York 10022, (212) 753-2095; **West Coast Bureau,** 101 North Robertson Boulevard, Beverly Hills, California 90211, (213) 659-3965; **Atlanta Bureau,** 789 Barnett, N.E., Suite 2, Atlanta, Georgia 30306, (404) 872-8592



### Space Invaders

That's how Acting FCC Chairman Bob Lee referred to direct broadcast satellites at presstime last month, shortly before the commission formally considered a DBS policy statement and rulemaking as well as the application for an interim DBS system filed by Satellite Television Corporation, a subsidiary of Comsat. By the time it was through, the commission gave STC and Comsat the go-ahead and established the necessary interim procedures, effective through the period leading up to the 1983 Regional Administrative Radio Conference.

"The idea of a national station or stations sitting up in the sky nearly boggles the mind," Lee commented, apparently with light regard for the phenomenon of the superstation. And, he added, "In the years to come the effect of a national broadcaster on our existing broadcast stations will have to be examined."

What really boggles the mind, however, and what will really have to be examined is how the new service will evolve pre-RARC '83. Another DBS application has been thrown into the hopper already—this one from Direct Broadcast Satellite Corporation, formed by a group of Comsat and Fairchild expatriates. The major difference between the Comsat venture and DBSC is that the latter intends to be a common carrier, at least offering its DBS capacity to other programmers and not functioning as the programming and transmission hybrid that STC proposes becoming.

The only certainty, however, is the uncertainty of it all. The commission has purposely decided not to assign specific frequencies and orbital positions to interim DBS operators until after RARC '83, but applicants may offer suggestions as to appropriate frequencies and orbital positions. The commission says it will consider all frequencies and orbital positions of equal value and the proposal does include provisional amendment of the Table of Frequency Allocations for authorization of DBS services in the 12.2 to 12.7 GHz band. What it has said is there is a need to go ahead because authorizing any experimental DBS service that requires a substantial investment by consumers or a substantial change in video services available to consumers is likely to have lasting implications for spectrum use in the 12 GHz band. And, it noted, a rulemaking is appropriate for addressing

fundamental spectrum allocations issues because demands on the 12 GHz band by fixed terrestrial services are increasing and because sharing of frequencies in the 12 GHz band between DBS and terrestrial services in a given geographic area will be difficult, if not impossible.

The most vocal opponent of the commission's approach to DBS, of course, has been the National Association of Broadcasters. "DBS does offer the opportunity to experiment with innovative improvements in service such as high-definition television. Recent technological developments in this area hold great promise for moving American television to a new, higher quality system," the association states. "A rush to approve what appears to be a premature technology which proposes to utilize a prime portion of the 12 GHz spectrum is not in the public interest." In fact, the NAB has called for Congress to establish a national policy first and then the FCC could decide whether the applications fit those parameters. In addition, NAB says, the commission should not push for quick deployment of the satellites since this would have profound implications for the U.S. position at both the 1983 and 1984 satellite conferences.

The commission continues to maintain that the knowledge gained from operating an experimental DBS system will help in establishing permanent regulations and allocating spectrum between DBS and other services. An experimental system will provide such information as consumer demand, competition in provision of the service and characteristics of the technology. It says it will attempt to accommodate interim DBS systems with as little disruption as possible to the terrestrial users now in the 12 GHz band. Upon assignment of frequencies by the commission to DBS systems after RARC '83, terrestrial licensees in the 12 GHz band would be required to provide protection from harmful interference to DBS systems.

*Pat Gushman*



# Can You Find the Positive Trap on this Page?

Can you find the positive trap on this page?

It's hidden in the cable, where it always belonged.

And if you didn't spot it, neither will your customers. Which makes Intercept's Positive Cable Trap the ultimate pay TV security system.

You see, by building the positive trap right in the cable, we eliminate the usual decoder box.

This just isn't more efficient, it's also more economical. You save because you don't need as much equipment. And you save because installation is faster. It's completely tamper proof. A standard security shield fits over the connector, and special tools are needed for removing.

Intercept's Positive Trap is made to work hard too. It doesn't require sensitive components for long term performance. And it'll take customer abuse without losing quality.

The Intercept Positive Trap works with any jamming system.

To find out more about Intercept's unique positive cable trap, write or call (see below).

We'll answer your questions faster than you can find the positive trap on this page.

At Intercept we are serious about our passives... that's why we treat them like our actives.

**INTERCEPT**

Intercept Corporation, 215 Entin Road, Clifton, New Jersey 07014

Telephone 201-471-2212



## Congress Seeks Control over FCC

WASHINGTON, D.C.—Legislation has been introduced in both houses of Congress in an attempt to gain stronger Congressional control over the Federal Communications Commission. Provisions in both versions of the legislation would establish a system of fees for various FCC services.

The first bill, introduced by Bob Packwood (R-OR), chairman of the Senate Commerce Committee, would authorize the agency for only the next three years. At present, the budget for the FCC is reviewed directly by a House Appropriations Subcommittee. Packwood's bill would require annual authorization of the FCC before the budget was appropriated.

The bill was co-sponsored by senators Barry Goldwater (R-AZ), Harrison Schmitt (R-NM) and Larry Pressler (R-SD). Specifically, it authorizes a budget of \$76.9 million for the next three fiscal years, beginning with the year ending September 30, 1982.

## Proposed FCC Fee Schedule

### Cable Television Services

CARS construction permit, new and renewals .....	\$250
Petitions for special relief and waivers .....	\$1,000

### Broadcast Services

Low-power TV station, initial construction permit:	
Application fee .....	\$500
Hearing charge .....	\$2,500
Grant fee .....	\$500

### Common Carrier Services

Local television or point-to-point microwave radio service:	
Initial construction permit or renewal .....	\$150
Satellite services:	
Initial construction permit for a commercial transmit/receive earth station .....	\$1,500
Renewals .....	\$500
Initial construction permit for a receive-only earth station .....	\$250
Renewals .....	\$50
Applications for authority to construct and launch satellites .....	\$2,000
Application for a satellite license .....	\$20,000
All Section 214 Applications .....	\$750
Tariff filings .....	\$300

**Table 1**

At the House subcommittee hearing in March, FCC Acting Chairman Robert Lee submitted a budget request for \$77,351,000 for the 1982 fiscal year. That figure was reduced from an original allocation request of \$82,167,000, which was planned prior to the Reagan administration's sweeping budget cuts.

At the same time, the bill introduces a fee schedule for various FCC licenses, permits and other actions. The license fees affecting cable companies are listed in Table 1. The fees may be lowered or raised by the FCC on an annual basis in amounts proportional to changes in the commission's total budget appropriation for the preceding two fiscal years. Such alterations of the fee schedule would not be subject to judicial review.

Also included in the Senate bill is a provision authorizing the FCC to assess penalties (not to exceed 25 percent) for late payment of the fees. All monies collected would be placed in the general fund of the Treasury "to reimburse the United States for amounts appropriated for use by the commission in carrying out its functions under this act."

The second bill was introduced in the House by the Subcommittee on Telecommunications, Consumer Protection and Finance which is chaired by Timothy Wirth (D-CO). The bill also attempts to gain oversight control over the FCC, but only authorizes the commission for one year. Under the bill, the FCC would be granted a budget of \$77,351,000, as Lee had requested in his revised appeal.

The House version also would grant the FCC authority to charge fees for its services. However, it would give the FCC the power to determine the fees.

## NCTA Names Bailey Science, Technology VP

WASHINGTON, D.C.—The National Cable Television Association has named Wendell H. Bailey, Jr., as its new vice president of science and technology.

Bailey, former manager of engineering, planning and coordination for MCI Telecommunications Corporation, will be the NCTA's liaison with the cable engineering community.

Bailey joined MCI in 1973 as a circuit engineer and was promoted to a senior engineer in 1974. The following year he became operations manager in charge of terminal operations at MCI's Washington facility. Beginning in March 1976, he served as manager of engineering,

overseeing systems engineers who were responsible for the design and construction of MCI's terminal facilities.

Prior to his stint with MCI, Bailey worked for American Telephone and Telegraph from 1966 to 1973. During his tenure with the Bell system, Bailey handled a number of assignments including maintenance and repair of multiplex and microwave systems, as well as private line services such as voice, data, wideband data, switched services and wideband data switch.



*Keeping track of FCC proceedings on signal leakage will be a top priority of the NCTA's new vice president of science and technology, Wendell H. Bailey, Jr.*

According to Bailey, there are numerous technological challenges facing the cable industry today. Among the most pressing issues are: signal leakage, 400 MHz, low-power television, VHF drop-ins, teletext standards and U.S. participation in worldwide satellite allocation proceedings. The rapid pace of changing technologies has already taught Bailey one valuable lesson.

"You've got to be quick afoot," he said. "Not all of this is new, though," Bailey continued. "Several technologies have just recently matured to the point where they're applicable. For example, fiber optics has been around for years, but it's only taken off in the last three or four. Its advantages don't make it as attractive as traditional cable in most instances right now. But one or two more breakthroughs and it will be fully competitive."

One of Bailey's top priorities will be keeping an eye on FCC proceedings

# A MOBILE UNIT FROM STOCK?

MIDWEST AND HITACHI TEAM UP TO BRING YOU

**BROADCAST QUALITY FOR UNDER \$100,000!**

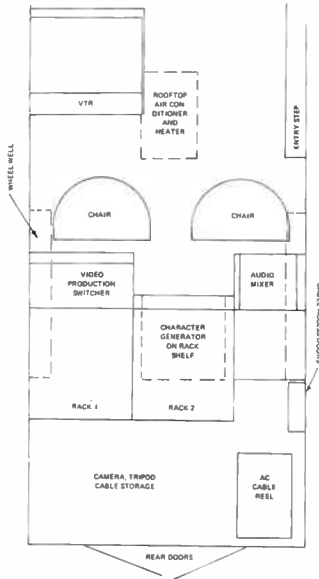

The MIDWEST M-1

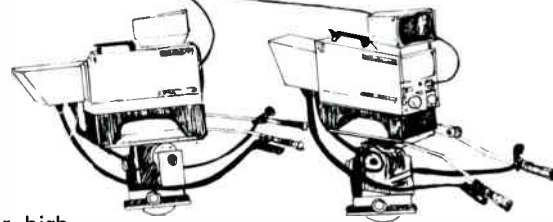

**THE M-1**, Midwest's answer to the demand for high quality mobile units in a hurry. Not an empty van with some equipment thrown in, but a fully equipped mobile teleproduction system, completely assembled and ready for use. Custom cabinetry and full carpeting provide a functional and comfortable interior. Low power consumption permits powering the entire unit from a standard 120 Volt/20 Amp outlet. The equipment complement selected is high grade and capable of delivering broadcast quality results.

Of equal importance to the overall quality of a mobile unit is its availability. When you have the budget approved, the unit selected, and programs waiting to be done, the last thing needed is a long delivery time. That's where Midwest comes through. If we can't deliver the basic M-1 within 30 days of your order, you get a \$2,000 discount.

And the best news is the price -

**\$99,800**

\*(Includes all standard equipment listed, does not include taxes, delivery charge, or options.)

## CHECK THESE FEATURES -

### EQUIPMENT

- (2) HITACHI FP40S 3-Tube Cameras
- (2) HITACHI OP40 Operation Panels
- (2) HITACHI VM-508 5" Viewfinders
- (2) HITACHI C-502 150' Camera Cables
- (2) FUJINON B10X10 Zoom Lenses
- (2) FUJINON Rear Lens Control Kits
- (2) QUICK SET Camera Heads
- (2) QUICK SET Tripods & Dollies
- (2) PANASONIC TR932 Dual 9" Monitors
- (1) VIDEOTEK VM8PR Color Monitor
- (1) TEKTRONIX 528 Waveform Monitor
- (1) VAC BPM-1 Burst Phase Monitor
- (1) ECHOLAB SE2 Production Switcher
- (1) QUANTAFONT QV Character Generator
- (1) SONY VO2860A UMatric Recorder/Editor
- (1) LENCO Video Distribution System
- (1) VIDEO Monitor Switcher
- (1) MICROTRAK 6455 Audio Console
- (1) TECHNICS RS-M65 Audio Cassette Deck
- (1) ELECTROVOICE 635A Microphones
- (4) MICROPHONE Cables - 150'
- (1) JBL Amplified Monitor Speaker
- (4) COMMUNICATIONS Headsets
- Equipment Storage Cases
- Video, Audio & Power Cabling

### VEHICLE

- New 1981 Econoline Type Van
- Automatic Transmission
- Power Steering and Brakes
- Van Air Conditioning
- Interior Insulation
- White Exterior Paint
- Beige Interior Carpeting
- Exterior Side Mirrors
- Weatherproof Cable Access Panel
- Custom Cabinetry and Consoles
- Interior Work Lights
- 120 Volt Distribution System
- AC Cable Storage Reel
- 120 Volt Air Conditioning

### OPTIONS

- Vehicle Roof-Top Camera Platform
- Pneumatic Antenna Mast
- On-Board AC Generator
- Custom Exterior Colors
- Custom Exterior Logos
- Custom Interior Colors
- Alternate Floor Plans
- Additional Cameras
- Time Base Corrector
- Editing Equipment
- Microwave Relay Systems
- Alternate Equipment Selection

Call for additional information

**800-543-1584**

CARL RAASCH  
SALES MANAGER  
MOBILE UNIT GROUP

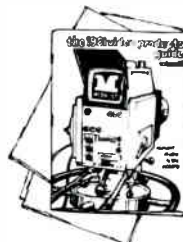

MIDWEST  
CORPORATION

1021 West 8th Street  
Cincinnati, OH 45203  
513-651-1904

 A UNR Company

NAME \_\_\_\_\_ TITLE \_\_\_\_\_  
COMPANY \_\_\_\_\_ PHONE (\_\_\_\_) \_\_\_\_\_  
ADDRESS \_\_\_\_\_  
CITY \_\_\_\_\_ STATE \_\_\_\_\_ ZIP \_\_\_\_\_

- Send 432 Page "1981 Video Products Guide"
- Send 432 Page "1981 CATV Products Guide"
- Send more information on M-1
- Have representative call me

Mail to: Midwest Corporation Mobile Units; 1021 W. 8th St.  
Cincinnati, Ohio 45203



regarding signal leakage. He termed the issue "a time bomb waiting to go off."

"The real bottom line is that unless the cable industry submits some solid comments and examples of workable solutions to the FCC, the commission will be forced to rely on the Federal Aviation Administration's comments," Bailey explained.

The problem with the commission relying on FAA information is that the FAA has been "totally intractable" in its approach to signal leakage problems, Bailey said.

"Some people are afraid that the FCC will end up requiring channelization," Bailey said.

As for the continuing attempt by some concerns to get the FCC to adopt foreign standards as the U.S. teletext standard, Bailey said such a move by the commission would be "totally premature."

"The broadcasters and the cable industry need to get their licks in to see if we can establish a U.S. standard," Bailey said.

## Reagan Appoints Dawson to FCC

WASHINGTON, D.C.—President Reagan has named a second Republican to the Federal Communications Commission. Mimi Weyforth Dawson, chief of staff and administrative assistant to Senator Bob Packwood (R-OR), will assume the term that is currently held by Acting Chairman Robert E. Lee. Lee plans to retire when the term expires June 30, giving Dawson a full seven years to serve.

Reagan's first move was to appoint Mark Fowler, Washington attorney, as his designee for commission chairman. Fowler is still awaiting confirmation from the Senate.

Dawson, 36, has served as chief aide to Packwood since 1973. She has been responsible for the operation of the senator's personal staff, the Senate Commerce Committee, which Packwood chairs, and the National Republican Senatorial Committee, also headed by Packwood. Those duties have made Dawson responsible for the management of budgets totaling \$16 million as well as the supervision of 100 staff members.

Since the Senate Commerce Committee is responsible for the confirmation hearings of FCC appointees, it is expected that Dawson will have little trouble clearing the formality. In fact, she received strong support in her bid for the commission seat from a number of prominent senators.

Although the Senate Communications Subcommittee falls under the jurisdiction of the commerce committee, Dawson's resume does not reveal an extensive background in communications matters. Her principal activities during her tenure

with Packwood were in the areas of budget, management coordination and policy development.

Dawson is a graduate of Washington University in St. Louis, Missouri (A.B., 1966). Prior to working for Packwood, she served as legislative assistant and press secretary to Representative Richard Ichord (D-MO).

The nomination of Dawson to the FCC leaves Reagan two additional seats to fill. It is expected that Commissioner James Quello will be nominated to one of the partial terms vacated by Charles Ferris and Tyrone Brown. Quello is a Democrat, and therefore Reagan would be able to add one additional Republican to tip the political balance at the commission to four-to-three in favor of Reagan's party. The name that is mentioned most frequently to fill the remaining slot is Henry Rivera, an Albuquerque, New Mexico, attorney.

## Technical Panels Scheduled For NCTA National Show

WASHINGTON, D.C.—The National Cable Television Association has released a tentative schedule for the technical panels to be held at the upcoming convention. Entitled "Cable '81: The Future of Communications," the annual show will be held May 29 to June 1 in Los Angeles.

The topics for the sessions reflect the more important technical concerns facing the cable industry. During the round tables, breakfast sessions and panel discussions, the following subjects will be discussed: fiber optics, addressability and security, 400 MHz, signal leakage, current satellite technology, audio services, videotex, cable-ready receivers, urban construction, rural construction, current component technologies, and FCC regulation.

The fiber optics panel will be broken down into two segments. The first has Wendell Bailey, vice president of science and technology for the NCTA, as moderator. Two papers will be presented: "Installation and Performance of 18-Channel Fiber Optics TVRO Link," and "Multi-Channel Video Transmission through Laser Diode-Based Fiber Optics Systems." The second half will feature a round table discussion of fiber optics by system operators who have used fiber optics plant.

The session on FCC regulation will be moderated by Bob Luff, vice president of engineering for UA-Columbia.

Next are two sessions on addressability. The first, hosted by James Fisher of Warner Amex, will offer information from equipment vendors. Representatives of Jerrold, Oak and TOCOM will discuss their products and the technology involved.

# E-COM's

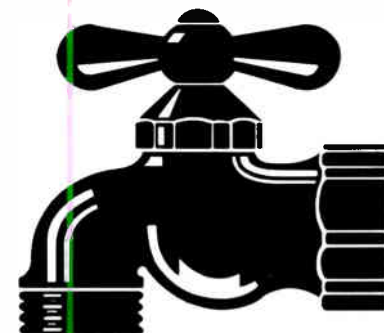

## TRU System Watches the Water in Clinton, Michigan

Water meters throughout Clinton County, Michigan will soon be read remotely through the local community cable system. At the heart of this system...TRU System Modems.

The unique TRU System operates using radio frequency transmissions on any standard coaxial cable network. Modular system expansion allows remote meter reading services to be provided to any size community.

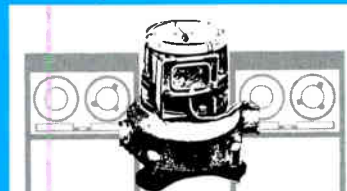

Capacity and versatility...built into every component of the TRU System for any two-way CATV application you have in mind.

To find out more, contact



P.O. Box 1538 West Chester, PA 19380

Toll-Free: 800-345-8286 (U.S.)  
800-662-2428 (PA only)

See us at the  
NCTA Convention  
May 29th - June 1st  
Los Angeles  
BOOTH # 312, Main Hall

# SATELLITE TONE SWITCHING DECODER

... The TOMCO Model TT-1000 is the most reliable satellite tone switching decoder known to earthman.

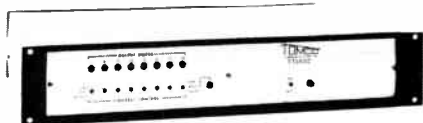

## FEATURES

- Automatically detects Satellite control tones and provides a contact closure for channel switching.
- Manual override capability for all eight outputs (form C contact closures.)
- Optional—telephone answering and tone decoding for remote control of the eight outputs (form C contact closures), includes programmable access code to prevent unauthorized acceptance of phone calls. A positive response indicates correct commands.

## TOMCO COMMUNICATIONS INC.

1145 Tasman Drive • Sunnyvale, California 94086 • 408/734-8401

Papers have been received on scrambling technology, addressable control, addressable systems and addressable converter control using the vertical interval.

The second addressability session will be moderated by Nicholas Worth of Telecable and will feature representatives of major MSOs.

The signal leakage discussion is titled, "How to Live with the FCC's 76.610 Rules and Regulations." Two of the papers scheduled for presentation are on new services versus the Federal Aviation Administration and a specific discussion of leakage problems.

The impact of three-degree satellite spacing on cable performance will be dealt with at the satellite technology session. Moderating the discussion will be Norman Weinhouse of Hughes Microwave.

The remaining sessions will have the following moderators: 400 MHz—Michael Jeffers of Jerrold; audio services—William Riker of Showtime; videotex—Dr. Gary Tjaden and Jeff Gates, both with Cox Cable; component technologies—Henry Cicconi of Sammons Communications; and cable-ready receivers—Jim Stilwell of Times Mirror.

The technical papers presented during the show will be available for purchase from the NCTA, according to Kathy Rutkowski, technical program coordinator.

## CableFile ('kābəl-fīl) *n.*

1. Indispensable reference manual for the CATV industry. 2. The most comprehensive and time-saving cable television directory. 3. The only directory published exclusively for the CATV industry. **syn see CABLE TOOL.**

## Cable Groups/Telcos Prepare for Rural Battle

WASHINGTON, D.C.—The battle lines have been drawn for the Federal Communications Commission's proceeding on telco/cable cross-ownership in rural areas. The issues that will ultimately evolve from the commission's deliberations will range from such esoteric concerns as the definition of "rural," to broader philosophical dilemmas such as who can best deliver the telecommunications revolution to the doorstep of rural America.

In a notice of proposed rulemaking issued last December, the FCC asked for comments on the possibility of eliminating the rules that bar telcos from offering cable service in their service areas. Currently, a telco can obtain a waiver in areas that have a population density of fewer than 30 homes per mile in the franchise area. The latest FCC proposals toy with the idea of eliminating that requirement altogether for rural classes.

The deadline for filing comments was April 6. Both the National Cable Television Association and the Community Antenna Television Association submitted filings on behalf of the cable industry; the United States Independent Telephone Association and the National Telephone Cooperative Association were two of the

more prominent participants on the other side of the issue. As can be expected, there was a vast difference in viewpoints.

"At the outset of this proceeding," read the massive filing from the NCTA, "NCTA wishes to stress that it has never opposed the concept of granting waivers to telephone companies seeking to provide cable television service to those rural franchise areas where cable service would not otherwise exist.

"However," it continued, "where independent cable operations are feasible, entry by a telephone company distorts the market due to its dominant market power, its control over essential facilities such as poles and conduits, and its proven incentive and ability to behave anti-competitively."

In the FCC notice, several possible criteria were suggested to define a rural area. They were: areas with fewer than 30 homes per mile in the franchise area; areas with fewer than 30 homes per mile in the telephone service area; a community with no more than 1,500 inhabitants; areas outside the top 100 major television markets; and areas outside the top 200 television markets.

Both USITA and the telephone cooperative association suggested expanding the population limit to 10,000 persons in their filings. USITA went on to offer the franchise area definition of rural as an alternative, except it wanted the upper limit raised to 40 homes per mile.

The NCTA has firmly stated that the cable franchise area is the only acceptable criterion for determining whether a telco should be given the option of applying for a cross-ownership waiver. Any other alternative, such as using the telephone service area standard, "would permit telco gerrymandering of service areas and frustrate commission objectives to insure competitive opportunity for the provision of an alternative broadband pathway," according to the organization.

In the NCTA's view, there is no reason to alter the present policy of requiring a telco to apply for a cross-ownership waiver to provide cable service in its own area, if the area happens to meet the fewer-than-30-homes-per-mile standard.

"Substitution of a rule exemption for rural areas will simply clear the way for a resumption of pre-1970 telephone company practices and the realization of the commission's fears regarding the lack of a competitive marketplace for broadband services," the NCTA said.

Within the filings were interesting uses of figures by both sides. The telephone cooperative association stated that its members build telephone systems basically through the use of money provided by the Rural Electrification Administration, which offers low-interest loans to cooperatives (generally at a five percent rate).

"Cable reaches over 16 million households, or 20 percent, of all TV homes in the United States," the filing read. (The actual figures are closer to 20 million households and 25 percent penetration.) "The REA telephone borrowers, on the other hand, serve only four million households and account for less than five percent of the nation's telephones. Moreover, while the net incomes of the CATV industry and REA borrowers are identical, cable is growing twice as fast."

According to an NCTA summary of its filing, "the assets of the 974 smallest, REA-funded telephone companies [\$5.7 billion in 1979] was \$2.5 billion greater than the entire cable industry and was 45 times greater than rural cable companies. . . .

"Similarly," it continued, "the 1979 revenues of these rural telcos [\$1.5 billion] was 116 times greater than the \$56 million earned by rural cable companies."

When the FCC sits down to deliberate these issues, it may decide to incorporate an alternative plan that was offered by CATA. In its filing, the organization stated that "assuming that the commission is simply interested in getting cable wired in areas where private, non-telephone entrepreneurs will not wire, then the solution is to prohibit the telephone interests from wiring anywhere that a private party is willing to undertake."

CATA's Steve Effros then offered even more direct advice.

"Low-power broadcasting and direct broadcast satellite transmission are far more sensible solutions to the rural telecommunications problem," he wrote.

## Jones Plans To Market V.V.S. Technology

DENVER, COLORADO—Jones International Ltd., parent company of Jones Intercable, has formed a new company—Jones V.V.S.—to develop and produce a new scrambling and bandwidth reduction technique called variable velocity scanning (V.V.S.).

Jones President Glen Jones said the technique is capable of reducing the bandwidth of conventional television signals from 6 MHz to 1 MHz. He indicated that V.V.S. is compatible with existing television transmission techniques.

The initial application of the technology, Jones said, would be to prevent pay television piracy, both from over-the-air services and satellite feeds, but he added that the bandwidth reduction characteristic of the technology would have several other applications. According to Jones, the number of conventional broadcast television channels could be doubled; the number of telephone conversations that can be transmitted over existing bandwidths could be increased

# E-COM's



## TRU System Transmits the Text for Times-Mirror

Telxon, Canada's world-beating Videotex system has been chosen by Times Mirror Cable Systems for the first comprehensive test of Videotex services. At the heart of the new service...the TRU System to transmit and receive the signals on the cable.

The reliability of the TRU System has been field-proven time after time. And TRU's flexibility is second to none...up to 14 TRX Expansion modules can be plugged into a single TRU remote modem allowing the performance of a wide range of intelligent functions without having to increase the capacity of your entire system.



Reliability and flexibility...the TRU System is the dependable answer to even the most sophisticated data communications needs.



P.O. Box 1538 West Chester, PA 19380  
Toll Free: 800-345-8286 (U.S.)  
800-662-2428 (PA only)

See us at the  
NCTA Convention  
May 29th - June 1st  
Los Angeles  
BOOTH # 312, Main Hall

# Avantek's AR-1000 brings satellite CATV receiver costs down to earth.

## Get broadcast-quality picture plus savings of 20% or more.

With new satellite CATV transponders coming and more programming available, the cost of adding channels is a major consideration in selecting a receiver. Avantek has the answer in our new Simulchannel™ AR1000 ... the most advanced expandable multichannel receiver available. You save more and more with every channel you add to the AR-1000.

## Use less space at your system's headend.

Imagine a six-channel receiver that fits into seven inches of a standard equipment rack, or twelve channels in just 14 inches. Compare that to bulky conventional receivers that eat

up many times as much expensive space.

## The secret is block downconversion to 1.2 GHz IF.

By combining the AR-1000 with Avantek's ACA-4220 LNA/downconverter at the antenna you can save the space

and cost of a separate downconverter for each receiver. By downconverting to the industry's new standard, centered on 1.2 GHz, you avoid interference from broadcast signals, while the 940-1440 MHz frequency range lets you use less expensive, more flexible cable.

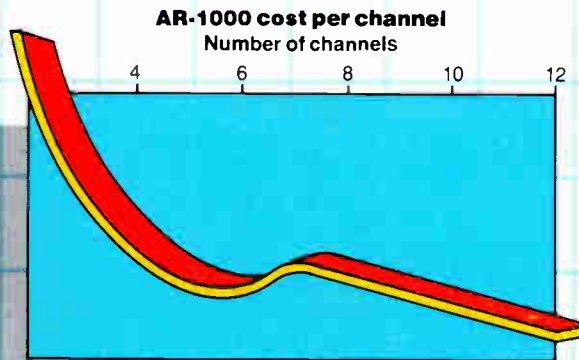

## Years of experience helped Avantek build the most advanced satellite receiver.

Avantek has supplied LNAs, oscillators, downconverters and test equipment to CATV businesses for more than ten years. During that time, we've made only the highest quality equipment. That's why the AR-1000 has features such as full digital tuning, threshold extension, automatic frequency control and 40 dB dynamic range.

## Learn how Avantek's AR-1000 can save you money and space.

Let us send you complete technical details. Then, ask us for a demonstration. We're sure you'll like what you see. Avantek, Inc., 3175 Bowers Ave., Santa Clara, CA 95051, (408) 496-6710.

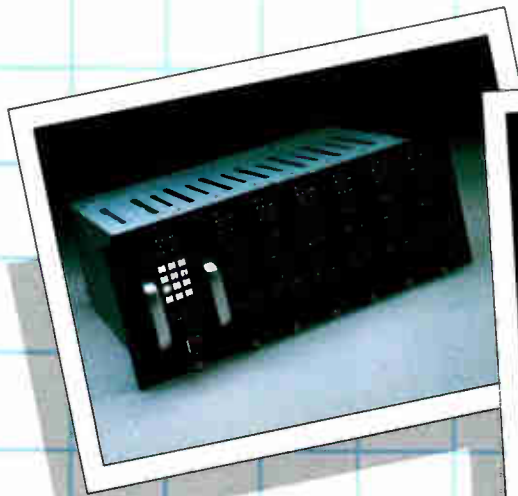

# Avantek

© 1981 Avantek, Inc.. Avantek and Simulchannel are trademarks of Avantek, Inc.

ten times; a two-minute facsimile transmission could be reduced to a few seconds; and a television set could receive stereo sound.

Jones said that Jones V.V.S. acquired the patents for the technology from V.V.S. Energy Patent Fund of New York in exchange for stock in the new company.

J.D. Nichols has been named executive vice president of Jones V.V.S., Inc., and will establish a research and development facility in Sacramento, California, to develop further the V.V.S. technology.

The V.V.S. technology is based on a high-speed picture-scanning process, storing the content and transmission of pertinent information under computer control. With V.V.S. it is possible to transmit some types of television signals with the same narrow bandwidth as is now being used by FM radio stations, according to Jones.

Unlike conventional TV electronic scanning of the video frame, Jones explained, the V.V.S. system uses microelectronics to store images in its memory and change picture transmission in nanoseconds if there is little change in the information. When the picture information changes rapidly, the scanning rate slows down to accept those changes, he said.

Jones said he expects the first V.V.S. units to be on the market within the year.

## Jerrold Reorganizes Engineering Operations

HATBORO, PENNSYLVANIA—The Jerrold Division of General Instruments has restructured its engineering organization to keep pace with developments in new technologies. One of the prime motivations for the reshuffling is a commitment toward developing direct broadcast satellite (DBS) terminals.

The engineering organization will now be split into three distinct areas: the Advanced Development for Broadband Communications Group, the Distribution Products Engineering Group, and the Subscriber Terminal Systems Group. Respectively, the heads of the areas will be Michael Jeffers, Frank Ragone and Anthony J. Aukstikalnis. All three men will have the title of vice president.

The Advanced Development for Broadband Communications Group will be responsible for developing the DBS terminals as well as other advanced technology. Jerrold has recently signed an exclusive agreement with SED Systems, a Canadian firm which manufactured the earth stations for the Canadian government's Anik B experiment with DBS. Under the agreement, Jerrold has licensed the technology developed by SED Systems "in order to produce commercially marketable DBS terminals,"

according to Ken Coleman, vice president of marketing.

Since DBS experiments are currently underway in Canada, Jerrold is looking to market the terminals in that country initially. Coleman said there is not a firm timetable for producing the units, "but we plan to be in production in approximately a year and a half," he said.

The Distribution Products Engineering Group will oversee the engineering for all headend, amplifier and passive products. Ragone has been with the company for 30 years and is one of the most experienced members of the Jerrold engineering team.

The third area, the Subscriber Terminal Systems Engineering Group, will handle the products that have changed the most in the last few years.

"Not too many years ago, converters were a rare thing," Coleman said. "Now they're omnipresent—every new system has more than 12 channels. Because this part of our business has gotten so much more complex, we felt that we should have a dedicated effort and a sufficient effort to continue to develop products at the proper level of technology."

Aukstikalnis comes to Jerrold from RCA, Astro Electronics Division, where he was manager of advanced development.

Coleman said the reorganization was necessary as Jerrold expands its manufacturing capability and the number of its employees to deal with the technology explosion.

"We've simply organized it this way for the purpose of getting management focused on the technologies and enough management so we can conduct all of these programs in a timely fashion."

## Satellites

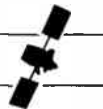

### Satcom Launches Delayed

NEW YORK, NEW YORK—The launch of RCA Americom's Satcom III-R and Satcom IV-F satellites has been postponed due to a malfunction in the key component of the rocket engine used to launch the birds, according to an RCA spokesman.

The component is located in the Payload Assist Module (PAM, the solid state rocket engine) which will be used in the RCA launch. The same module was employed successfully in the launch of Satellite Business Systems' SBS 1 last November.

According to the RCA spokesman, NASA and McDonald Douglas, the main contractor for PAM, are investigating the problems and are optimistic that both satellites will still be launched this year. Originally, Satcom III-R was scheduled to go up in June and Satcom IV in October.

## E-COM's



## TRU System Sounds the Alarm... all around the Country

Subscriber security services are one of the best ways to expand your CATV system's capacity and generate extra revenue. At the heart of these services...the TRU SYSTEM which can monitor heat and smoke detectors, intrusion alarms, medical alert terminals while reading the water meter, controlling pay TV channels and adjusting the thermostat.

The TRU System features microprocessor intelligence, full duplex operations, AC/DC or cable power, self-testing, back-up battery options, and much much more.



Quality and economy...The TRU System is the low-cost answer to the whole field of ancillary CATV services.

For the TRU story, contact



P.O. Box 1538 West Chester, PA 19380

Toll-Free: 800-345-8286 (U.S.)

800-662-2428 (PA only)

See us at the  
NCTA Convention  
May 29th - June 1st  
Los Angeles  
BOOTH # 312, Main Hall

## “Inductive My Dear Watson, ... Direct and Inductive!”



Yes, Watson, to trace as well as determine the depth of buried cables, pipes and wires you must have all capabilities at your fingertips.

**TRACKER II SYSTEM** by Progressive Electronics places a silent-tone on the cable, pipe or wire, which is then tracked by the receiver.

This Model 507 is capable of these three major applications:

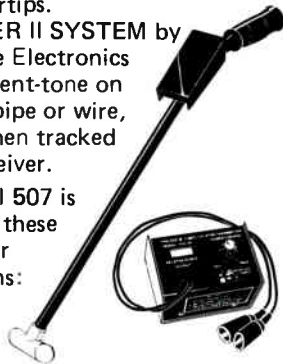

- o **DIRECT CONNECTION** of the tone-transmitter to the cable, pipe or wire...or...
- o **INDUCTION CLAMPING** when the conductor cannot be de-energized or taken out of service...or...
- o **INDUCTIVE ANTENNA** when direct connection is not possible.

And Watson, my good fellow, in just minutes you can be detecting & tracing these faults or conductors since the Model 507 System is so simple to use. It is also ruggedly built to withstand normal abuse, and comes with a full year guarantee against defects in parts and workmanship.

? *The cost?* Lowest in the industry for its unique features and uncompromising quality. Only **\$553.00** (+tax and shipping) for the complete **TRACKER II SYSTEM** (High-power Transmitter, Receiver, Headphones, Carrying Case with Inductive Coupler and Antenna). Prices subject to change without prior notice.



**TO ORDER TODAY Call Toll-free  
800 528-8224 or Write:**

Detector Headquarters

**PEI PROGRESSIVE  
ELECTRONICS INC.**

432 S. EXTENSION MESA, AZ 85202  
Innovative Electronics Since 1970

The birds will not be operational until one or two months after launch due to tests and the time required for the satellites to drift into their orbits.

Customers currently on Satcom I were to be moved to Satcom IIIR (the new Cablenet I), while those on Comstar D2 were to be relocated to Satcom IV.

When the original Satcom III was lost in space in late 1979, RCA leased transponders for its Satcom III customers on AT&T's Comstar D2 bird. Under the RCA/AT&T contract, RCA is guaranteed 11 preemptible transponders from June 1980 through June 1981. From June to the end of the year, the contract guarantees RCA only six transponders and provides an option for more, provided they are available.

RCA is currently negotiating with AT&T to extend its time on Comstar. Spokesmen from both RCA and AT&T said there would be no problem in extending the transponder leases.

### Westinghouse, Western Union Sign Transponder Agreements

NEW YORK, NEW YORK—Westinghouse Broadcasting Company has signed major transponder agreements with Western Union Telegraph Company, according to Daniel L. Ritchie, Group W president and chief executive officer.

The agreements are for use by Group W of ten satellite transponders on Westar IV and V. Five of these transponders will be leased to Group W from the capacity available on Westar IV, which is scheduled for operation in the first quarter of 1982. The additional five transponders will be provided, through a combination purchase and lease agreement, from capacity available on Westar V, which is scheduled for operation in the fourth quarter of 1982. Group W also has obtained options for the purchase and lease of transponders on Westar VI, which is currently planned for launch in the second half of 1983.

In a separate transaction, Group W has agreed to provide for the transfer of a 50 percent interest in these transponders to the Teleprompter Corporation in the unexpected event the proposed merger between Group W and Teleprompter is not consummated. The merger, which received the approval of Teleprompter's shareholders on April 2, remains subject to government approval.

### SCTE News



### SCTE Sponsors Digital Seminar

DENVER, COLORADO—The Society of Cable Television Engineers' two-day seminar, "Digital Electronics and Cable TV," drew 55 participants here last month.

The seminar was designed to provide a basic understanding of digital technology and to inform engineers how they can continue to learn about digital technology on their own.

On the second day, Gilles Vrignaud of Catel presented a paper on high speed PCM data transmission in cable television systems. The discussion dealt with PCM coding, implementation of PCM data transmission in cable systems and the interfacing of PCM and RF equipment.

The seminar concluded with a discussion of Cabletext and information delivery systems by Selman Kremer, vice president of marketing and sales for Southern Satellite Systems. Ten years from now, Kremer predicted, the price of integrated circuits will be low enough for cable firms to offer subscribers data service decoders in the \$100 to \$150 range. Until then, businesses and institutions are the principal markets for data services on cable.

### Business Notes



★ **Local Digital Distribution Company**, a joint venture between M/A-COM and Aetna Life and Casualty Company, has been awarded a contract by the Las Colinas Association for a network communications architecture design for its Irving, Texas, community. The wideband local communications network will provide audio, data and video services over multiple coaxial cables.

★ The **Jerrold Division** has begun shipping its Starcom™ 58-channel digital converters from regular factory production, according to Jerrold Division President Colin O'Brien. The first factory shipment of the digital converters was sent to MacLean-Hunter's cable television system in Wayne, Michigan. It is a part of MacLean-Hunter's suburban Detroit complex that includes East Detroit, where Jerrold and MacLean-Hunter demonstrated the 400 MHz distribution system last summer.

★ Two former Valtec executives, Richard A. Cerny and Tadeusz Witkowicz, have formed their own fiber optics communication systems manufacturing company. The new company, **Artel Communications Corporation**, will produce video and related fiber optic transmission systems. Cerny was previously marketing director for Valtec Communication Fiber-optics, a position he held since the division was formed in 1975. Witkowicz previously managed Valtec's systems group, since forming it in 1978. The company's products will include terminal equipment and systems that multiplex, process and transmit information signals (video, voice and data) over fiber optics cables.

# FUSED DISC® III

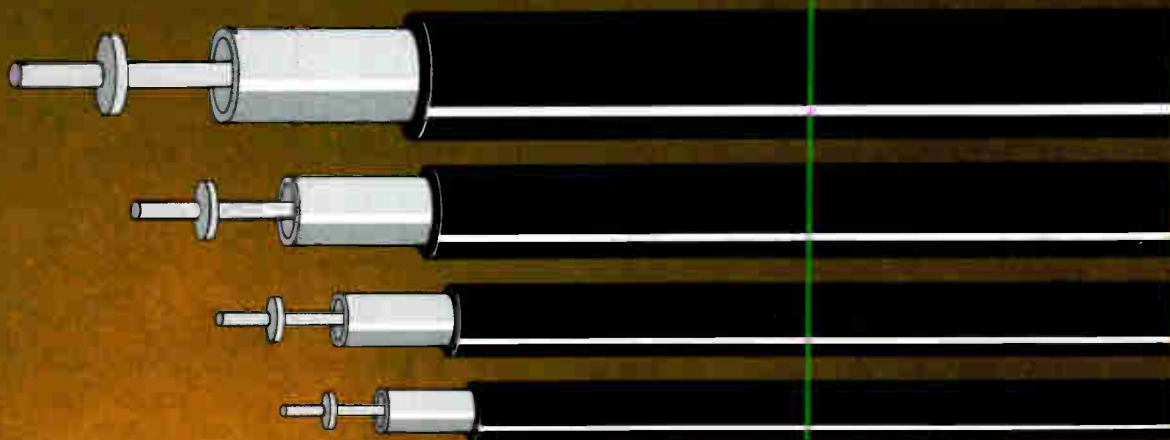

## Today...

Fused Disc® III is the standard in low-loss cable system design. This unique design provides you with:

- Maximum Efficiency Hub Design
- Reduced Electronics and Power Supplies
- Lower Maintenance Costs
- Lower Energy Costs

## And Tomorrow...?

An extraordinary concept in Fused Disc® is just over the horizon. Don't miss our exhibit, booth 156, at the NCTA show.

---

*More and more systems are being built, re-built and expanded with our cable. For an information package on this high performance cable, write:*

*General Cable Co., CATV Division,  
P.O. Box 700, Woodbridge, N.J. 07095  
or call Toll Free: (800) 526-4241,  
if calling from N.J. dial: (201) 636-5500.*



**General  
Cable**  **CATV**  
a GK Technologies company DIVISION



26/May 1981



# 400 MHz: Not As Easy As $A \pm B \pm C$

By Peter N. Smith, Director, New Systems Engineering, American Television and Communications Corporation.

One of the more important aspects of any franchise proposal is channel capacity. Because of increased franchising competition it was only natural that cable companies would propose systems beyond 300 MHz upper bandwidth limit. The most common bandwidth extension is to 400 MHz, but systems as high as 550 MHz have been proposed. Regardless of the actual bandwidth and number of channels, this large an increase has caused several problems for operators. This article addresses some of those problems, offers potential solutions and suggests where further research is needed. It will deal specifically with 400 MHz and 52 channels, but it can be modified for any system configuration.

## Composite Triple Beat

In a 300 MHz, 35-channel system using standard frequency assignments, a computer run of all possible  $F_1 \pm F_2 \pm F_3$  type triple beats shows that the worst case number of beats falling on one channel is 334 on Channel 11 or 12. Theoretically, if all channels were exactly on frequency, as shown in Figure 1 on page 28, the beats would all fall on the same frequency and add on a voltage basis. In practice, channels do drift slightly in frequency and all of the beats fall in a narrow band around the video carrier of the affected channel.

Because there are so many beats so close together, they tend to add on a power basis and appear as narrowband noise on a spectrum analyzer. For lack of a better description, the picture resembles horizontal noise streaking. Extensive subjective testing has demonstrated that the threshold of perceptibility is approximately 52 dB. It would normally be

assumed that Channel 11 or 12 would be the worst case because the number of beats is greatest. Actual lab and field testing has shown, however, that because of a frequency dependent transfer function, the worst case is actually at Channel W. It is typically 1 to 2 dB worse in level than Channel 11 or 12, using standard composite triple beat (CTB) measurement techniques.

In a 52-channel system, the worst case number of beats using standard assignments is 842 in Channels O and P. If the CTB function were truly linear, the difference in level between 35 and 52 channels could be computed on a power addition basis relative to the number of beats of sources. This would yield a

number of approximately 4 dB. Unfortunately, the frequency dependence now comes into effect even more dramatically. It has been found that the CTB level increases by 10 to 12 dB with the move from 35 to 52 channels. Again, the worst case is the highest frequency channel. In order to maintain the same 52 CTB level, the average output levels of all amplifiers would have to be lowered by 5 to 6 dB. This, coupled with higher cable and passive device losses at 400 MHz, could increase system costs dramatically.

## Solution or Problem?

A headend technology developed several years ago has been revitalized to

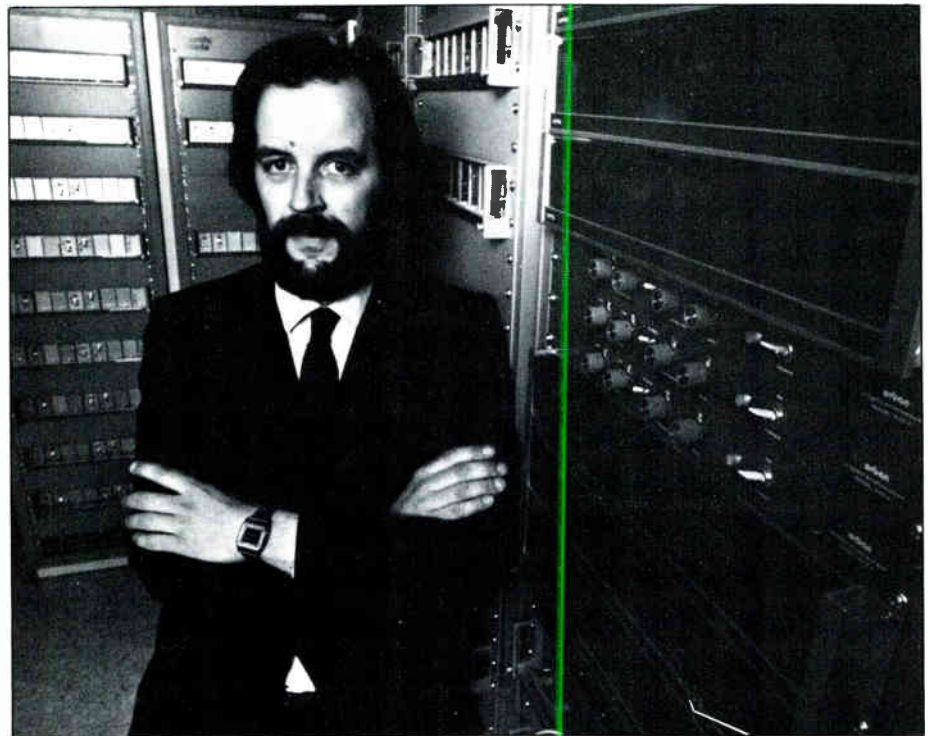

Peter N. Smith standing beside the 400 MHz harmonically-related carrier headend in ATC's Littleton, Colorado, system.

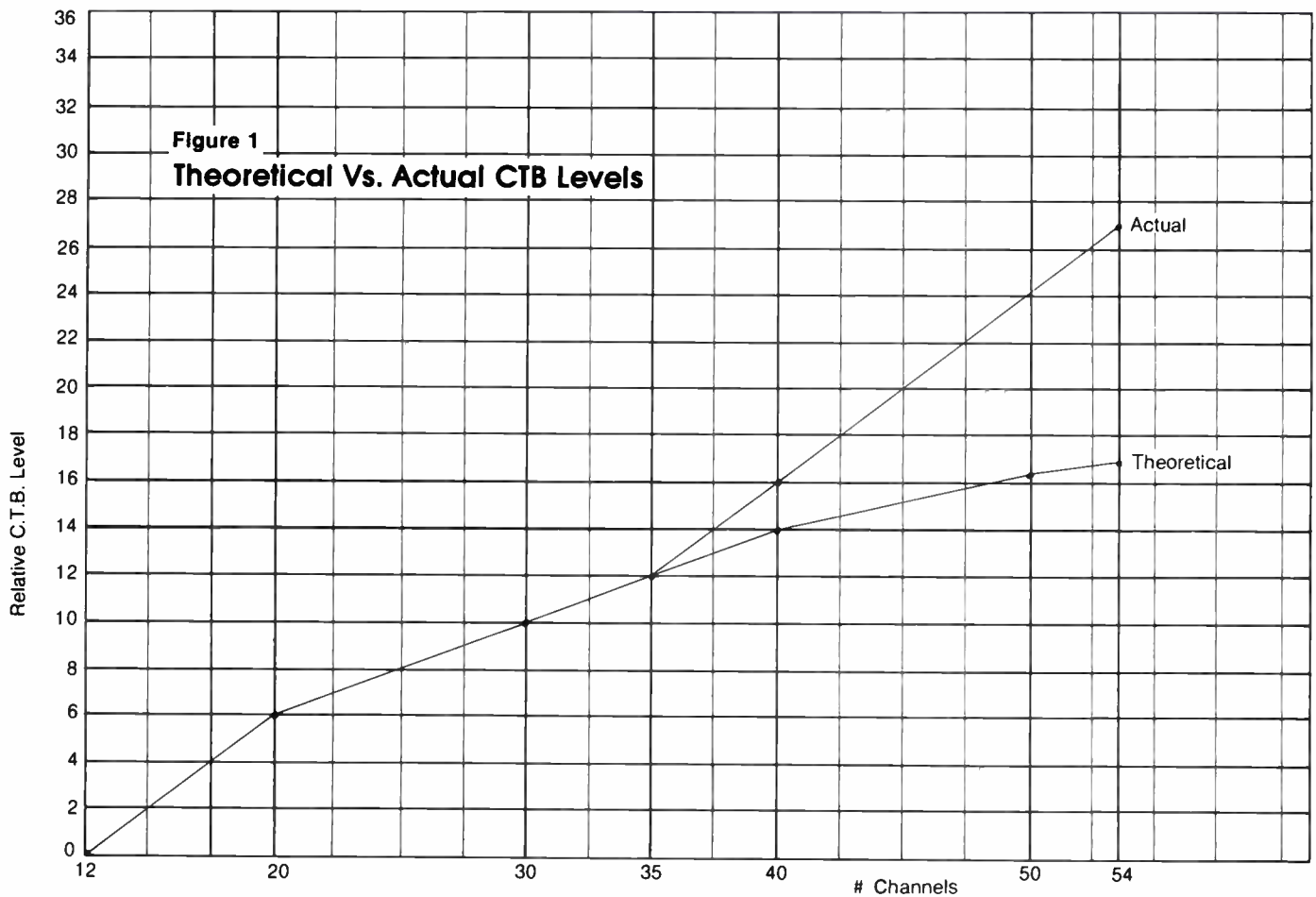

# LECTRO STANDBY POWER FIVE YEAR WARRANTY

After five years of field operations in the heaviest lightning areas of the U.S.A, Puerto Rico and Mexico, where the most frequent power failures occur, we found by the records kept that Lectro Standby Power supplies had such a low failure rate we could offer a warranty unprecedented in power supplies in the cable industry.

That means there is no cost to you other than shipping charges to and from our factory, unless the unit has obvious physical damage. We will repair at no charge, and return the unit within one week of receipt.

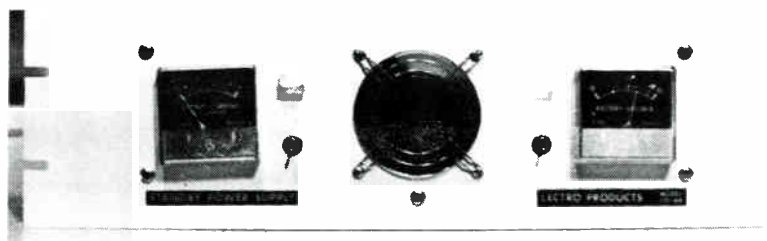

SH-0-3-11-0

Lectro has proven that you do not have to pay high prices for reliability.

Our five year warranty now gives you further proof of this. Sales over the past three years show that Lectro is now the leader in standby power.

**Why not use  
the leader in  
your system!**

**COMMUNICATIONS  
DISTRIBUTION CORP.**

P.O. Box 567 • Athens, Georgia 30601  
(404)353-1159

Status Monitoring Interface Available

# VITAL SIGNS

Make 8,640,000  
Measurements Per Day With  
Texscan's On-Line ATE System



Making more than 100 measurements per second, Vital Signs helps predict problems before they become failures and saves time, manpower and money in correcting system malfunctions.



Vital Signs transponder modules interface with most CATV distribution amplifiers and are internal on the Theta-Com XR2+ and 'T' series. Each module performs up to 8 individual measurements including, signal levels, AC/DC voltages and currents, temperatures, and reverse bridger switching and status.



A computer controlled interrogator monitors each transponder location in turn and alerts the system operator if a fault is found. Isn't it time you had your own Vital Signs system? Vital Signs is available now. Call today for price and delivery.

See us at the NCTA—Booth 255

©Texscan Corporation 1981  
#1—1/30/81

## There's a representative near you:

Western—(916) 533-1235  
Mountain—(505) 281-2311  
South Western—(214) 867-1049  
(713) 466-8153

Southeastern—(813) 962-2752  
Northeastern—(201) 821-7422  
Midwestern—(812) 334-2241  
(612) 933-8922

# Texscan

Texscan Corporation  
2446 N. Shadeland Ave.  
Indianapolis, Indiana 46219  
(317) 357-8781

Texscan Theta-Com CATV  
2960 Grand Avenue  
Phoenix, Arizona 85061  
(800) 528-4066

Texscan MSI  
3855 South 500 West, Suite S  
Salt Lake City, Utah 84115  
(801) 262-8475

gain back some of the CTB losses associated with increased channel loading. Harmonically-related carrier (HRC) headends use a master 6 MHz oscillator comb generator to phase lock all channels together to retain exactly the same spacing from each other at all times. Because of this, all triple beats on one channel fall at the same frequency, which is zero beat with the affected video carrier. Most channels will be shifted from standard frequency by -1.25 MHz. For example, Channel 2 will be at 54 MHz rather than 55.25 MHz. The only exception to this are Channels 5 and 6, which are shifted by +.75 MHz and, because of the usual 4 MHz space between 4 and 5, an extra channel (4+) can be inserted in the low band. At first glance, HRC would seem a bad idea in that the resultant triple beats, which now total 920 because of the different frequency assignments, would add on a voltage basis in that they are all the same frequency. This is true, but the instantaneous phase of each beat must also be taken into account. It would seem that the actual level of the resultant beat would vary dependent on the result of all the instantaneous phase additions. It is difficult to predict this level. Therefore, to see what improvement is achieved by the use of HRC, picture quality must be evaluated subjectively. Because all of the

beats fall at exactly zero beat, the threshold of perceptibility will improve dramatically and the limiting factor becomes beats between two video carriers and the first horizontal sideband of a third. It appears in the picture in the same manner as cross-modulation, but testing has shown that it is a beat rather than an actual cross-over of modulation onto the affected channel. The improvement in output capability of the system when HRC is added is in the 3-4 dB range. For example, in a 52-channel system without HRC if the levels were raised until distortion could be seen and HRC added, the levels could be increased again by 3-4 dB before an equivalent distortion could be seen. The appearance of the distortion in the two cases would be different. That is why there is some room for debate on the actual numbers.

With regard to system calculations, 44-46 dB CTB would be used as the limiting distortion factor. Because of the increased bandwidth, it will be more difficult to maintain an equivalent frequency response, and it would seem wise to use the more conservative 45 dB specifications.

### Cost Analysis

Higher costs are associated with both buying an HRC headend and designing a system to operate without HRC. The

question then becomes: Which method is more cost efficient for a given system?

In order to answer this, two sets of amplifier operating levels, one to achieve 52 dB CTB and one to achieve 46 dB CTB, were set up. Then, 12 miles of design were completed for both sets of levels and a bill of materials generated for each, including labor and material costs. The result was a \$287 per mile increase for the lower level non-HRC design. At the same time, bids for headends under both HRC and non-HRC configurations were received from three vendors. The packages included 52 channels forward on the subscriber system, 21 channels forward on an institutional system, eight modulator/demodulator combinations for the reverse subscriber system (two each on four cables), and nine modulator/demodulator combinations for the institutional channels, which share spectrum space with the downstream subscriber system (Channels 2-6), were phase locked together. This was accomplished in the HRC case with reconstructive comb generators. In the standard case, upstream was simply phase locked to downstream. This was done to reduce the effects of cables cross-talking between each other.

The average cost increase for HRC was \$51,800. In the standard case, spare equipment was estimated at \$10,000 and the HRC was estimated at \$40,000

## We're Better Than Ever!



The new **TPT-2500** titler offers features not expected in this price range: eight character sizes, upper and lower case, border line, underlining, graphics, flash, crawls, positionable title window, 32 page resident memory and optional 700+ page tape memory.

Operating features include: auto line and page centering, word/line open and close, tab and elastic memory.

**Priced at \$4995.00**



### Video Data Systems T.M.

Headquarters, Hauppauge, N.Y. (516) 231-4400  
National CATV Sales / Western Regional Office  
Salt Lake City, Utah (801) 272-9296

→ Innovative Communications

See us at the NCTA—Booth 203

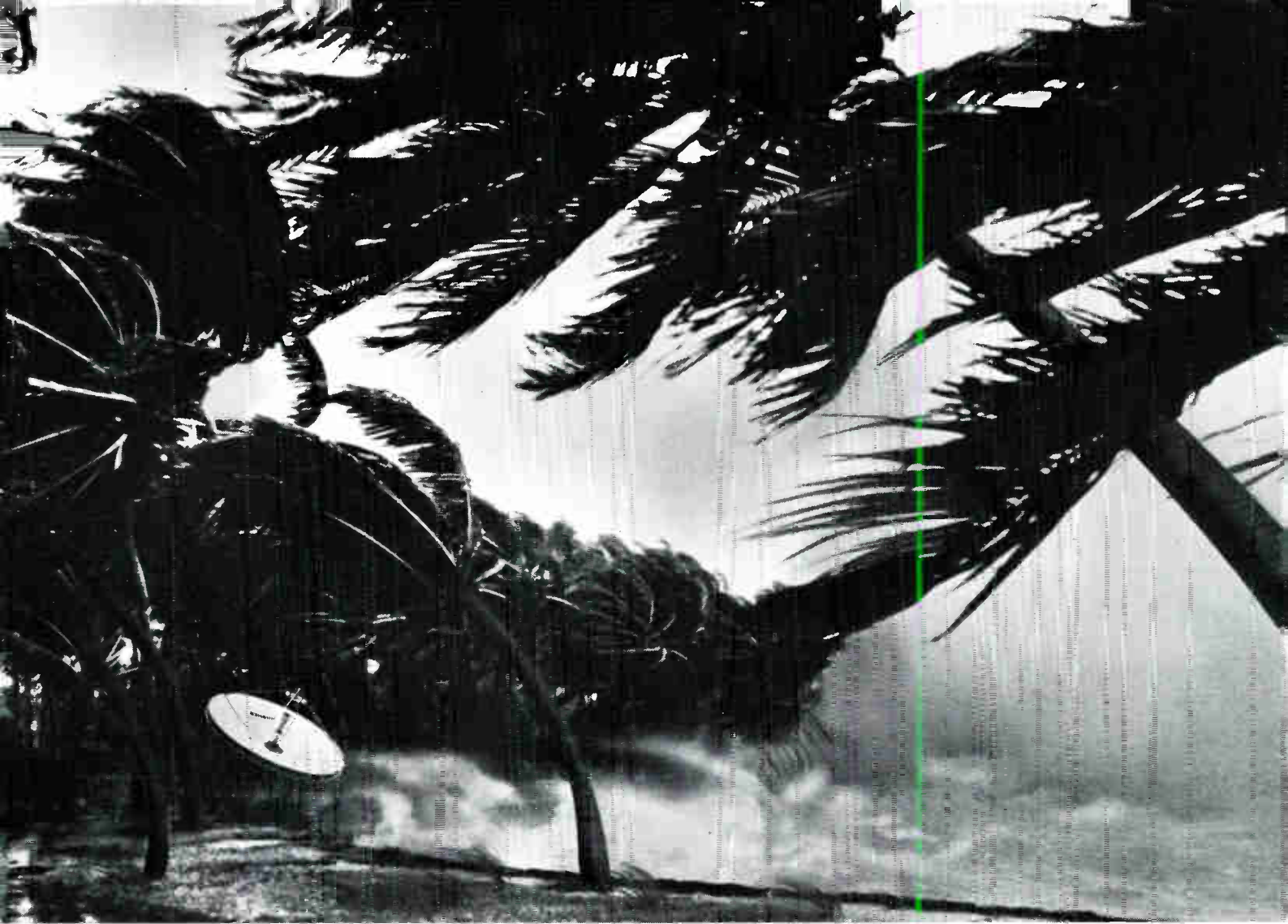

## Can the building inspector do what Mother Nature can't?

If it's a Hughes antenna, neither one can bring it down. Because Hughes convertible 5 to 6 meter antennas are built and certified to pass the Uniform Building Code. Surprisingly, some antenna manufacturers ignore that rather basic consideration.

The rugged, computer-designed mount uses torsionally stable tubular members instead of conventional angle iron. And anti-friction bearings let you adjust azimuth and elevation easily when you want to orient (or re-orient) the antenna.

These Hughes antennas provide two feed options; a high gain Cassegrain design for maximum gain in weak signal areas, and a focal point feed for strong signal areas. The 5 meter antenna can be

easily converted to 6 meters should additional gain be required at some future date. And all Hughes receivers have built-in 24 channel agility, threshold extension and remote control capability.

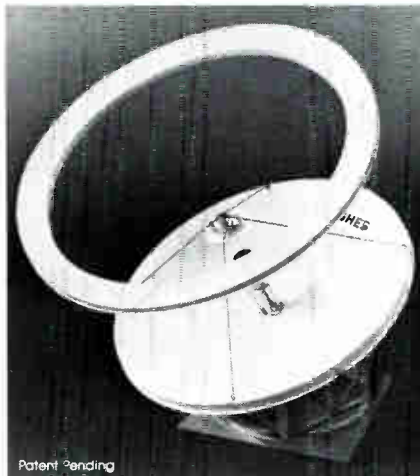

Patent Pending

So if you require earth stations in more than one location, choose Hughes. Then you'll be ready for anything, including satellite or transponder changes, EIRP degradation and the building inspector.

For more information, write Hughes Microwave Communications Products, P.O. Box 2999, Torrance, California 90509.

Lean on the leader to keep ahead.

**HUGHES**

**MICROWAVE™  
COMMUNICATIONS  
PRODUCTS**

© Hughes Aircraft Company

For emergency service nights or weekends,  
call (213) 534-2170

See us at the NCTA Show—Booth 257

because tunable up converters cannot be used due to the necessity for phase lock. Therefore, the total headend cost difference is approximately \$81,800. Dividing this by the increased plant cost gives the breakeven point in plant miles above which HRC is cost effective but below which HRC is not cost effective. The breakeven point for this analysis is 285 miles. This figure holds in single headend systems. Obviously, spares would only be bought once for multi-hub systems, and a change in amount of institutional equipment would affect the breakeven point. The subscriber headend should always be figured for maximum loading, as the system design levels are typically calculated at maximum loading.

It is somewhat doubtful whether a 285-mile, 400 MHz system with one headend is even practical. It could be justified, however, if system reach could be extended and a hub saved because of HRC. Each particular case deserves its own analysis because expanded bandwidth does not necessarily mean HRC headends.

### Other Problems

Even if the analysis shows HRC is cost justified, there are other problems that must be considered. Because all VHF channels are offset from standard assignments, strong off-air channels can no

longer be phase locked. This will increase the possibility of interference by about 15 dB and mean that system maintenance will have to increase accordingly. As many non-critical services as possible should be placed on channels that are subject to this type of interference.

Another problem in HRC systems is FAA interference. Previously, in standard assignment systems, the solution to this problem has been to offset the interfering channel a small amount to be in compliance with FCC rules. Because of the master comb generator in an HRC system, this is no longer possible and affected channels must be abandoned. In one large city this means losing Channels A and V, but in another large city 18 channels are lost, turning a 52-channel system into a 34-channel system. The FCC has a notice of proposed rulemaking pending on the FAA issue, which it appears will take a while to resolve. The increase in level required for reporting may go from  $10^{-5}$  watts to  $10^{-4}$  watts, which would not help video carrier interference. The 18 conflicts are all video carrier problems.

At this point, it does not seem to make sense to use HRC in small systems, and large systems deserve a fair amount of analysis. There are a few questions that still need more study. What is the true subjective distortion improvement by

going to HRC in a real operating system, and what is the best repeatable measurement technique to use for distortion in an HRC system?

In an effort to get a better handle on these and other problems, ATC is designing its Littleton, Colorado, system to achieve a 52 dB CTB with 52 channels and will also buy an HRC headend. The system is approximately 120 miles but will include a few 20 amplifier cascades. A full range of testing for both picture impairments and distortion levels will be possible.

Another question that will be answered is: How much headroom is necessary to allow normal, routine maintenance costs to be approximately the same as in 300 MHz systems? Results of the testing will be published this summer. It is hoped that other operators of expanded bandwidth systems will publish the results of their experiences so that the entire industry can benefit.

*Peter N. Smith has overall engineering management responsibilities for 25 ATC systems, including Memphis, Tennessee; Kansas City, Missouri; Rochester, New York; and Wichita Falls, Texas. Littleton, Colorado, is his first 400 MHz system.*

## The Harris Satellite Video Receiver..... Quiet Quality

### Quietness is Important.

- A quality video receiver is silent and invisible, processing signals with no degradation. The sound and video fidelity of Harris Model 6522 Receiver is outstanding.
- A quality video receiver must reject noise. Under low signal conditions when pictures from other receivers break up, Harris Model 6522 delivers good video. Our tracking filter demod\* makes the difference.
- A quality video receiver must do its job without demanding attention. Install a Harris 6522 Receiver, then ignore it. You'll get reliability. If it fails (nothing is perfect forever), call our 24-hour telephone service number (305) 724-3000.

\*Patent applied for.



#### FEATURES :

Frequency agility, local or remote control; automatic polarization switching; dual conversion.



HARRIS CORPORATION Satellite Communications Division  
P O Box 1700 Melbourne, Florida 32901 305/724-3000  
TELEX 56-7488



## How to get the sensitivity you want without getting burned, lagged, or bloomed. Introducing the Panasonic WV-3900 Newvicon®.

Now you can make dark scenes look brighter and bright scenes look better. Just shoot with the Panasonic WV-3900 EFP color camera. With its Newvicon tube, it'll let you see more of what you want and less of what you don't.

The WV-3900's Newvicon tube offers low lag, a minimum of blooming and burn-in, yet at the same time plenty of sensitivity. Standard illumination is only 140 footcandles at f/5.6, while a

flip of the high-gain switch results in minimum illumination of just 7 footcandles at f/2.2.

Still, there's even more to the WV-3900, like a very quiet S/N ratio of 50 dB with recommended illumination. Plus horizontal resolution of 270 lines at center. And when it comes to power requirements, the WV-3900 is very flexible. It operates off its own internal rechargeable batteries, a portable VCR, external DC

or a camera control unit.

In the field, the WV-3900 is totally self-contained. Everything from genlock, to subcarrier phase adjustments, to aperture corrections is built in. So is a 1.5" (meas. diag.) CRT viewfinder, a directional microphone and a 10:1 power zoom lens with an auto/manual iris.

There's also a color bar generator, a four-position color temperature filter wheel and a rugged alu-

minum die-cast chassis.

In the studio, the Panasonic WV-3900 is no outsider when you add our optional remote control unit, 5" (meas. diag.) CRT viewfinder, and studio lens conversion kit for rear-controlled zoom lens.

Audition the WV-3900. Don't be surprised if what you don't see is as impressive as what you do.

**Panasonic**  
VIDEO SYSTEMS DIVISION

TECHNICIANS... ENGINEERS... DON'T MISS THE

# **EASTERN SHOW**

SPONSORED BY THE SOUTHERN CABLE TELEVISION ASSOCIATION

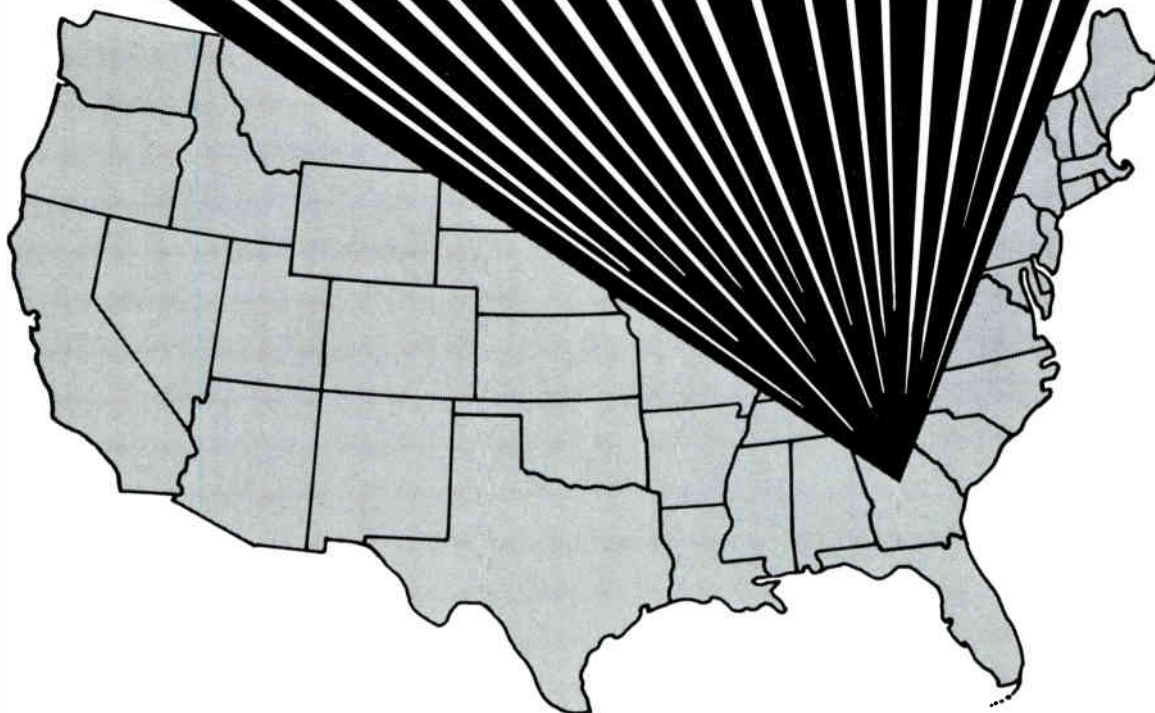

THE LARGEST CABLE TV TRADE SHOW EAST OF THE MISSISSIPPI

## **IN ATLANTA...**

- HUB OF THE CABLE INDUSTRY IN THE EAST
- OVER 300 EXHIBITS ON ONE SHOW FLOOR
- GALA ENTERTAINMENT!
- STIMULATING SEMINARS FEATURING LABOR RELATIONS, PROGRAMMING, TECHNICAL & REGULATORY MATTERS

— PLUS —

CABLE TV NITE AT ATLANTA STADIUM

**AUGUST 20, 21, 22, 1981**

GEORGIA WORLD CONGRESS CENTER

PLAN TO BE THERE! CALL OR WRITE: Southern Cable TV Association,  
3355 Lenox Road NE, Suite 750, Atlanta, GA 30326 / (404) 237-8228



# Comparing dBs and Dollars With a Hand-Held Calculator

Co-authored by Steven P. Lowe, Sr., and Dr. Robert Sam Lackey.

*A new antenna design × LNAs with lower noise temperature × a better receiver = ? And for how much?*

**W**hether you are mixing and matching earth station components for the first time or are an old hand keeping up with the multitude of new and sometimes improved products, one thing is clear. Evaluating earth station components on a dB/per dollar basis is typically difficult, tedious and time-consuming. But not this time.

This article, with the help of a programmable calculator, will enable you to evaluate many different combinations of earth station components in seconds. The following program was written for a Texas Instruments calculator, model TI-58 or TI-59. It is readily adaptable to other machines, however.

The results of the evaluation will be the carrier-to-noise and video signal-to-noise ratios of the complete earth terminal downlink.

The variables that you may plug in are the following:

1. Antenna noise temperature
2. LNA noise temperature
3. Receiver noise temperature
4. Gain or loss of antenna feed
5. LNA gain
6. Gain of antenna
7. EIRP of the satellite of interest
8. Path loss
9. Bandwidth of the receiver intermediate frequency in MHz

You will then be able to change these variables to many different configurations and, with a push of the button, evaluate the results in terms of carrier-to-noise and video signal-to-noise ratios.

Now let's tackle the program. Program entry is very straightforward. Turn the machine on and push the LRN (learn) key. Now you can enter the program directly as shown in Table 1. One thing to watch out for is that an asterisk (\*) beside a program step indicates this is the second function of a key. Now enter the program.

Your machine is now ready for use. Let's try an example, using the following variables:

Antenna noise temperature = 23° K  
LNA noise temperature = 120 K  
Receiver noise temperature = 12 dB

Feed loss = .98 dB  
LNA gain = 50 dB  
Antenna gain = 44 dB  
EIRP in dBW = 34 dBW  
Path loss in dB = 196 dB  
Receiver I.F. BW = 36 MHz

Now enter the antenna noise temperature of 23° K. Push 23. Then push A. Display shows 23. Enter the LNA noise temperature of 120 K. Push 120. Then push B. Display shows 120. Enter receiver noise temperature of 12 dB. Enter 12. Then push C. Display shows 4306. (The display is showing 12 dB converted to

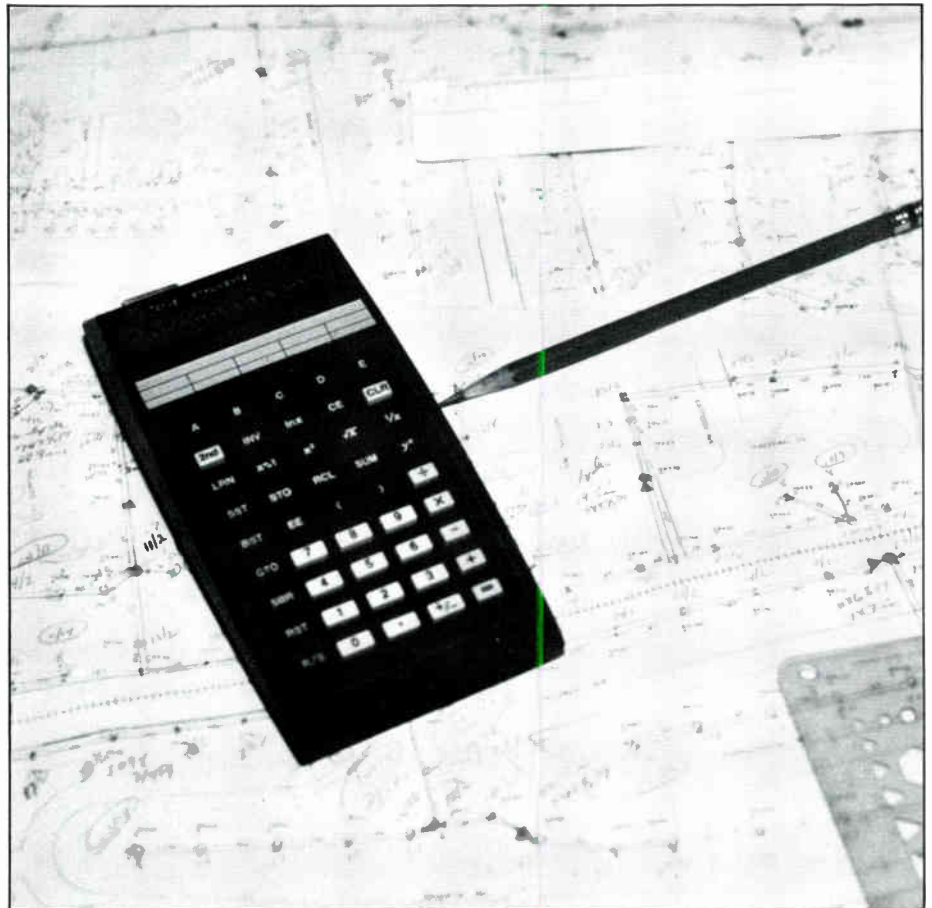

# COMTECH DATA CORPORATION PRESENTS A NEW AGILE RECEIVER

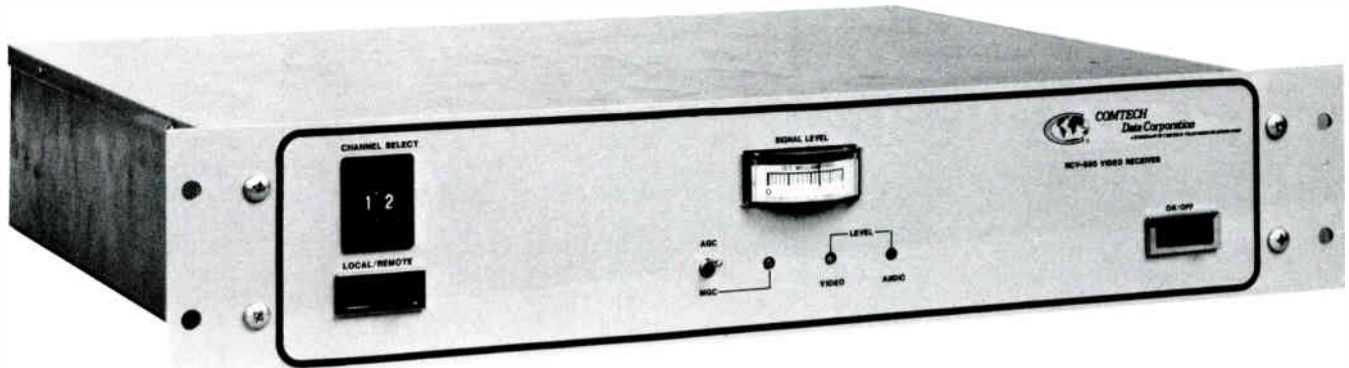

## NEW PRICE

- As low as a fixed tuned receiver
- Volume discounts

## NEW FEATURES

- Digital tuning
- Polarity control
- Smaller size
- 6.2 Mc/6.8 Mc Switch Selectable Prog. Demod

## NEW OPTIONS

- Multi-channel audio
- Various remote tuners

Call us today for prices and delivery.

See Us At The NCTA Show—Booth #1126



**COMTECH**  
*Data Corporation*

A SUBSIDIARY OF COMTECH TELECOMMUNICATIONS CORP.

613 S. ROCKFORD DR. • TEMPE, AZ 85281 • (602) 968-2433 • TWX 910-950-0085

### Common Variables

Receiver Noise Figure  $\approx 12$  dB  
 Receiver I.F. Bandwidth  $\approx 30$  MHz and 36 MHz  
 Antenna Feed Loss  $\approx .98$  dB  
 LNA Gain  $\approx 50$  dB  
 EIRP  $\approx 34$  dBW (Satcom FI Footprint of Mid-America)  
 Path Loss  $\approx 195.5$  dB Mid-Band Average Loss

Table 2

### Antenna Costs

Antenna Size	Gain	Cost
3 meters/10 Feet	39.43	\$2,295
3.3 Meters/11 Feet	40.12	\$2,795
3.66 Meters/12 Feet	41.10	\$3,800
4 Meters/13 Feet	41.70	\$3,895
4.6 Meters/15 Feet	42.95	\$5,400
5 Meters/16 Feet	44.50	\$6,275
5.6 Meters/18 Feet	43.51	\$7,800
6.1 Meters/20 Feet	45.46	\$9,000
7 Meters/23 Feet	46.60	\$11,900

Table 3

degrees Kelvin.) Now enter feed loss of .98 dB. (If no gain or loss of Gf [label D] is to be indicated, enter 1 dB. Entering the value of .98 dB as listed in Table 2 is a safe estimate for most antenna feed system losses. In any case, enter only values greater than 0.0 and no greater than 1.0 so that the mathematical ratios will function properly.) Push .98 and then push D. Display now shows .98. Now

### Earth Station Evaluation Program

*Lb1	÷	10	12	*Pause
A	10	=	R/S	*Pause
STO	=	STO	*Lb1	36
01	INV	07	*e'	÷
R/S	*LOG	R/S	RCL	4
*Lb1	=	*Lb1	09	•
B	STO	*a'	+	2
STO	05	STO	RCL	=
02	RCL	08	10	*LOG
R/S	01	-	-	x
*Lb1	+	RCL	RCL	10
c	(	07	11	=
÷	RCL	=	-	+
1	02	STO	(	7
0	÷	09	2	•
=	RCL	R/S	2	9
INV	04	*Lb1	8	5
*LOG	=	*b'	•	+
-	)	STO	6	7
1	+	10	+/-	•
=	(	R/S	)	7
x	RCL	*Lb1	-	8
2	03	*c'	RCL	+
9	÷	STO	12	1
0	(	11	=	3
=	RCL	R/S	INV	=
STO	04	*Lb1	EE	+
03	x	*d'	STO	RCL
R/S	RCL	STO	13	13
*Lb1	05	14	*Pause	=
D	=	EE	*Pause	STO
STO	)	6	*Pause	15
04	)	*LOG	*Pause	R/S
R/S	=	x	*Pause	LRN
*Lb1	STO	10	*Pause	RST
E	06	=	*Pause	
STO	*LOG	STO	*Pause	
16	x			

Table 1

### Antenna Size Noise Temperature/Evaluation Angle

Elevation Angles	15°	20°	25°	30°	40°	50°	60°
3 Meters/10 Feet	31°	28°	25°	24°	22°	21°	20°
3.3 Meters/11 Feet	28°	25°	23°	21°	20°	19°	18°
3.66 Meters/12 Feet	40°	36°	31°	28°	23°	20°	18°
4 Meters/13 Feet	26°	23°	21°	19°	18°	17.5°	17°
4.6 Meters/15 Feet	32°	28°	25°	24°	22°	21°	20.5°
5 Meters/16 Feet	31°	29°	27°	25°	22°	21°	20°
5.6 Meters/18 Feet	47°	43.5°	41°	39°	37°	35.5°	34.5°
6.1 Meters/20 Feet	26°	23°	21°	19.5°	18°	17.5°	17°
7 Meters/23 Feet	21°	19°	18°	17°	15°	15°	14°

Example: 4.6-meter dish with elevation angle of 30° sustains an antenna noise temperature of 24°K. (Antenna noise temperatures in degrees Kelvin come from manufacturers' specification sheets.)

**Table 5**

### Evaluation Equations

Carrier-to-Noise

$$C/N = G/T + \text{EIRP} - L_p - K - 10 \text{ LOG B}$$

Where G/T Is the System Figure of Merit

$$G/T = G_a - 10 \text{ LOG T System}$$

G<sub>a</sub>=Antenna Gain

T<sub>sys</sub>=Total System Noise

Temperature in Degrees Kelvin Defined As

$$T_{\text{sys}} = T_A + \left( \frac{T_{\text{LNA}}}{G_f} \right) + \left( \frac{T_{\text{RX}}}{G_f \cdot G_{\text{LNA}}} \right)$$

Where T<sub>A</sub>=Antenna Noise Temperature in °K

T<sub>LNA</sub>=LNA Noise Temperature in °K

T<sub>RX</sub>=Receiver Noise Temperature in °K

G<sub>f</sub>=Gain or Loss of Antenna Feed in dB

G<sub>LNA</sub>=Gain of LNA Expressed As a Power Ratio

Where EIRP=Satellite of Interest Predicted Signal Level Obtained from a Footprint Map in dBW

Where L<sub>p</sub>=Free Space Attenuation=195.49 dB

Where L<sub>p</sub>=20 LOG D + 20 LOG f + 96.6

(We will use 195.5 dB where (D) equals 22,300 miles and (F) equals 3.95 GHz.)

Where K=Boltzman's Constant of (-228.6)

B=Receiver I.F. Frequency in MHz

Peak-to-Peak Video to RMS Noise Ratio

$$S/N = C/N + 10 \text{ LOG} \left[ 3 \left( \frac{\Delta f}{f_{\text{vm}}} \right)^2 \left( \frac{BW}{2f_{\text{vm}}} \right) \right] + 10 \text{ LOG 6} + 13$$

Where S/N=Video Signal-to-Noise Ratio

C/N=Carrier-to-Noise Ratio

Δf=Peak Video Deviation (Calculator program assumes typical deviation of 10.5 MHz.)

f<sub>vm</sub>=Maximum modulation frequency (Calculator program assumes typical maximum modulation frequency of 4.2 MHz.)

BW=Receiver I.F. Bandwidth (As per Carson's Rule - 36 MHz)

10 LOG 6=The difference Between Peak-to-Peak Video and RMS Noise Conversion Factors

13=A Combination of 2.5 dB Preemphasis Factor and 10.2 dB Noise Weighting Factor as Defined by CCIR Curve

**Table 6**

enter the LNA gain of 50 dB. Then push E. Display shows 21.62.

Now we can enter the gain of the antenna. Push 44, and then push 2nd A'. Display shows 22.37. (This is the infamous "system figure of merit" expressed in dB/K.)

Now enter the EIRP. Push 34 2nd B'. Display says 34.

Now enter the path loss of 196. Push 196, and then push 2nd C'. Display shows 196.

We can now enter the receiver intermediate frequency (I.F.) bandwidth of 36 MHz. Push 36, and then push 2nd D'. Display shows 7.55.

Now that all of those variables are plugged in, you merely have to push 2nd E'. The machine will first calculate the carrier-to-noise ratio and flash this answer ten times. Then it will continue the calculations and arrive at the video signal-to-noise ratio. In this case, push 2nd E', and 13.40 will flash. This is the carrier-to-noise ratio. The display will show 51.47, and this is the calculated video signal-to-noise ratio.

Now that your machine is programmed and functioning correctly, you are ready for your own custom analysis of the complete satellite downlink.

Listed in Tables 2 through 5 are typical antenna gains and other variables which may be plugged in for a preliminary analysis before consulting the various manufacturers' specification sheets.

### LNA Costs

LNA Noise Temp.	Typical Cost
90° K—1.2 dB	\$1,900
100° K—1.3 dB	\$1,590
120° K—1.5 dB	\$1,090
140° K—1.7 dB	\$ 895
180° K—2.1 dB	\$ 875
238° K—2.6 dB	\$ 795

**Table 4**

# Ad Index

AM Cable TV Industries	3, 18
Avantek, Inc.	22
BEI	56
Ben Hughes Communications	65
BP Electronics	12
Communications Distribution Corp.	28
Communications Supply	19, 21, 23
Comm/Scope Co.	11
Compucon, Inc.	41
Comtech Data	36
Conifer Corp.	57
CWY Electronics	56
di-tech	18, 66
Eagle Comtronics	83
Eastern Show	34
Electroline Television Equipment	10
General Cable	25
GTE/Sylvania	59
Harris Satellite Corp.	32
Hughes Microwave Comm.	31
Intercept Corp.	14
Lowell Light Mfg.	17
Microwave Associates Communications	62-63
Microwave Filter Co.	70
Mid-America Video Corp.	54
Midwest Corp.	16
North Supply Co.	44
Oak Industries	2
Pico, Inc.	73
Panasonic/Video Systems Division	33
Pioneer Communications	9
Progressive Electronics	24
RMS Electronics	4, 76, 84
Sadelco	71
Scientific-Atlanta	55
TEST, Inc.	49
Texscan Corp.	29
Times Wire & Cable Co.	74-75
Tomco Comm., Inc.	20, 42-43, 68
Toner Cable Equipment, Inc.	6
Trans USA Corp.	40
Triple Crown Electronics	54
TRW RF Semiconductors	52
Video Data	30
Vitek Electronics	60
Wavetek Indiana, Inc.	51

One variable which is harder to deal with is the antenna noise temperature. First, one must know the look angle or elevation angle at the location of interest. (CED 11/80, p. 43., *Aim Your Dish Like a Pro.*)

Then you must look at the antenna manufacturer's specification sheet to determine the noise temperature for your elevation angle. However, the following statement should be noted for practical application. Antenna noise temperature contributes little to the overall system noise temperature when station elevation

angles are 20° and over. At elevation angles of less than 20°, the antenna noise temperature contribution is more significant and should be taken directly from the manufacturer's specification sheets and entered in calculations accordingly.

By the same token, remember that for earth receiving stations with antenna apertures of or in excess of 4.5 meters, the low-noise amplifier (LNA) should establish the carrier-to-noise ratio for the full system.

You now have the vital information

## Pertinent Equations

Approximate Gain of a Parabolic Dish with 55 Percent Efficiency:

$$G = 20 \text{ LOG } B + 20 \text{ LOG } F + 7.5$$

Where G=Gain Over Isotropic Antenna in dB  
F=Frequency in GHz  
B=Parabola Diameter in Feet

Half-Power Beamwidth of a Parabolic Antenna Is Given  
Approximately by:  $\theta = 70/FB$

Where  $\phi$ =Half-Power Beamwidth in Degrees  
F=Frequency in GHz  
B=Parabola Diameter in Feet

Metric Conversion Factors:

Multiply Feet x .3048 to Get Meters.  
Multiply Meters x 3.281 to Get Feet.

Table 7

## Angle Elevation

$$E = -\tan^{-1} \left( \frac{(6.6362 \text{ Cos } C \text{ Cos } X) - 1}{6.6362 \sqrt{1 - \text{Cos}^2 C \text{ Cos}^2 X}} \right)$$

Where

E=Elevation Angle in Degrees  
C=Difference in Degrees Between the Satellite's Longitude and the Earth Station's Longitude  
X=Earth Station Latitude in Degrees

Table 8

# TUSA<sup>®</sup> CONVERTERS—

The specs match the best,  
the prices don't.

Today's TV viewers are increasing their demands for more and more channels. As a result, they are increasing the costs needed for you to meet these demands.

TUSA CVU-40 and CMHI-7 converters match the features of the best known converters—at a price they can't match.

#### The TUSA difference

Available for prompt delivery... TUSA converters are in our warehouse now. In stock, and ready to go. Just a phone call away.

Price... Both the CVU-40 and CMHI-7 are affordably priced to save you money. Each is priced up to 50% LESS than other comparable units.

Superb Features... reliable. High performance features such as:

- Flat frequency response
- Low distortion
- Dependable VSWR
- Regulated power supply.

#### Model CVU-40

- Converts mid and super-band to UHF channels.
- Side keyholes allow for fast mounting almost anywhere... attic, basement, wall, etc.
- Rugged metal housing provides good shielding.

#### Model CMHI-7

- Converts mid-band to high-band for receiving 7 additional channels.
- Simple button operation employs pin diodes so switches take less stress, last longer.
- Durable metal housing provides good shielding.

#### Check us out and compare.

A TUSA converter is the answer to your immediate pay TV problems. The TUSA combination of economy and dependability is unbeatable.

Meet the demands of tomorrow... today. With TUSA. Call Trans USA Corporation or your TUSA distributor.



## TUSA<sup>®</sup>

Trans USA Corporation • 158 Tices Lane  
East Brunswick, N.J. 08816 • (201) 254-3020



# The Tomco Printing Event Timer

We've added a printer to our PT-3000 Program Event Timer to give you something no other timer can. Key in a simple command on the typewriter keyboard and you can get a concise listing of all programmed control times in chronological order, you add a few messages via the alphanumeric keyboard and you have a usable print out for logs etc.



## Features

- Available with either 8, 16 or 24 output channels with a 208 stored times per channel.
- Programmed with extensive error checking to facilitate easy user data entry.

The unique printer, automatically prints time of power outages (time power went off and time power returns). Of course the PT-3000 has a built-in battery for power back-up to insure all control functions are activated during the power outage.

- Fourteen available program commands, example: LIST command prints contents of displayed channels in chronological order.
- Automatically prints time of power outages (time power off and time power returns).
- Audio beep can be used as a local alarm clock for a reminder of real time appointments, etc.
- Alphanumeric keyboard and printer, allows use to add comments to printouts for logs and messages.
- Keyboard override capability allows user to easily change any of the eight outputs.
- Display mode indicates the current status of all outputs and real time.
- The PT-3000 has been designed so that future add-on features can be field installed, as they become available.

Write or call for information about this great new product from Tomco.

## Tomco Communications, Inc.

1145 Tasman Drive  
Sunnyvale, California 94086 408-734-8401





Scientific-Atlanta



Tomco

## Tomco would like to clear up a few things.

Like your reception, for one. Tomco's switchable output and input converters offer crystal stability on VHF; AFC on UHF.

Your standby converter problems may be cleared up for good. Our input converters tune from channels 2-83 and include AGC compatibility. Our output converters tune from channel 2-W and HRC frequencies are available. No problem link-ups, no extra parts, no waiting around. Just clear reception...immediately.

Let us clear up one more thing. Scientific-Atlanta no longer sells Tomco parts. Which means you can come clear to the source for the same quality converters you've been using all along.

**Switch back to Tomco.**

## Tomco Communications Inc

1145 Tasman Drive  
Sunnyvale, CA 94086  
(408) 734-8401

### Tomco Representatives:

**Northeast;** Northern CATV Sales, Inc. (800) 448-1655  
**West Coast;** CATV Services (800) 227-1200  
**British Columbia;** Techcom Sales (604) 437-6122  
**Montreal;** Incospec (514) 322-5540  
**Ontario;** Sigmacom Systems (416) 666-1661

# Get acquainted with the Supermarketplace<sup>®</sup> for CATV Equipment Supply!

## NORTH SUPPLY

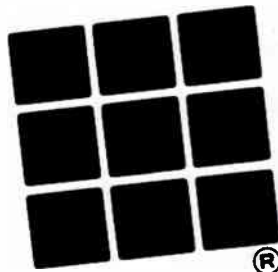

North Supply Company • 10951 Lakeview Avenue  
Lenexa, Kansas 66219 USA • Phone: 913-888-9800  
Telex: 426388 • TWX: 910-749-6494  
**(800) 255-6458**



We're North Supply, introducing a **product/service** combination like you've never seen before!

Start with delivery. We ship from stock within 24-48 hours, **surface freight prepaid and allowed**. That goes for any size order, large or small.

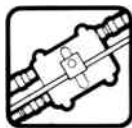

Not only can we sell you equipment, we also offer a **unique leasing program**, featuring quick approval with no run-around. The North Supply Leasing Program means you can have the equipment you need immediately, without a large cash outlay.



And our product experts can give you sound advice in selecting components and **designing systems**. Access to this in-depth knowledge is as fast as a phone call.



We carry only the most up-to-date, **brand name products**, including:

- Connectors
- Electronics and Earth Stations
- Splitters, Taps and Passives
- Underground Products
- Wire, Cable and Strand

You **save on storage and inventory costs**, because North Supply warehouses these



products for you at 11 distribution centers coast-to-coast.

And, our **computerized inventory control system** monitors your order from entry to shipment.

For these reasons and more, North Supply is a source you'll want to get to know. Start by asking for your copy of our new fully illustrated Supermarketplace<sup>®</sup> catalog of CATV products.

**Cable, hardware and more now available for immediate delivery. Call toll-free (800) 255-6458.**

NORTH  
SUPPLY  
COMPANY

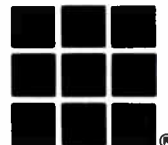

See us at Booth #106, NCTA in L.A.

# Coaxial Cable: The Connecting Link

Raleigh B. Stelle III, who was recently promoted to vice president at Texscan Corporation, concludes his series of articles on test equipment with an overall view of the properties of coaxial cable.

**T**he basic properties of cable that a technician must understand include resistance, reactance and impedance. Once the basics are covered, this article will discuss such subjects as the effects temperature changes have on delivery of service, the havoc that can result from poor handling of cable during installation and a formula for eliminating ghosting.

## Resistance

Resistance, as stated by Ohm's law, is simply the characteristic of a circuit that limits the flow of current. Resistance may be the given value of a circuit component called a resistor, or the quantity of resistance in wire, cable or other circuitry. Resistance, by definition, is a value in ohms at zero frequency (DC). It is stated in equation form in Figure 1.

Figure 1

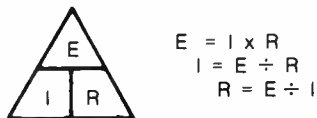

When dealing with frequencies greater than zero (AC), resistance is no longer sufficient to give a complete picture. An additional term known as "reactance" must be employed.

## Inductive Reactance

Inductive reactance ( $X_L$ ) is that portion of total circuit reactance which is pro-

vided by coils, chokes and transformer windings. Any device in which wire is wound circularly around some type of core is an inductor. Inductors are current devices. Inductive reactance ( $X_L$ ) increases as frequency increases—thus, an inductor passes low frequencies more easily than high frequencies. The reason for this is due to the fact that current flowing through the wire in an inductor generates a magnetic field about the inductor; the intensity of the magnetic field determined by the value of current, and the direction of the field determined by the direction of current flow. For a constant (DC-zero frequency) value of current, the intensity and direction of the magnetic field are constant. As a result, current flows easily through the inductor, since the inductor appears, to the current, to be nothing more than a length of wire. Magnetic fields, by nature, do not like to change, and when they do change, they do so slowly. Thus, in order for an inductor to conduct a changing (alternating) current, the magnetic field *must* change as the magnitude and direction of current change.

Clearly, the magnetic field can change more easily at low (slow rate of change) frequencies than at high (high rate of change) frequencies. Therefore, the inductive reactance,  $X_L$ , in ohms, of a circuit, increases with both frequency and the value of the inductor (value of inductor given in "Henrys"). Figure 2 shows this in equation form.

## Capactive Reactance

Capactive reactance ( $X_c$ ) is that portion of total circuit reactance caused by capacitance. Any time that two conducting surfaces are placed parallel to each other and are separated some small distance by a non-conducting substance, the result is capacitance. This is exemplified by the circuit component known as a capacitor. Capacitors are voltage

devices. Capactive reactance (as opposed to inductive reactance) decreases as frequency increases. Therefore, a capacitor tends to pass high frequencies more easily than low frequencies. To understand this, remember that a capacitor is simply two parallel conductors separated by a non-conductor. Therefore, it is basically an open circuit, and current cannot flow through it. At DC (zero frequency) a capacitor acts simply as an open circuit and consequently blocks a DC current or voltage level.

Figure 2

$$X_L = 2 \pi FL$$

where X = Reactance in ohms  
F = Frequency in cycles  
L = Inductance in Henrys  
 $\pi = 3.14159...$

When voltage is applied to a capacitor, an electric field is generated between the two conducting surfaces. This is what occurs when a capacitor "charges." Electric fields, like magnetic fields, do not like to change in intensity, but will do so slowly. Thus, if a changing voltage (frequency greater than zero) is applied to one side of a capacitor, the electric field in the capacitor resists change and in order to maintain a constant intensity between the two conducting surfaces, pulls the other side of the capacitor along with the first side. Thus, a changing voltage applied to one side of a capacitor appears on the other side and causes a corresponding current to flow in the far side of the circuit (no current flows through the capacitor). Since the electric field has more time to change at low frequencies, the output of a capacitor follows the input better when frequency is high. Thus, as frequency increases,  $X_c$  decreases. The actual value of  $X_c$ , in ohms, is inversely proportional to the value of capacitance (mea-

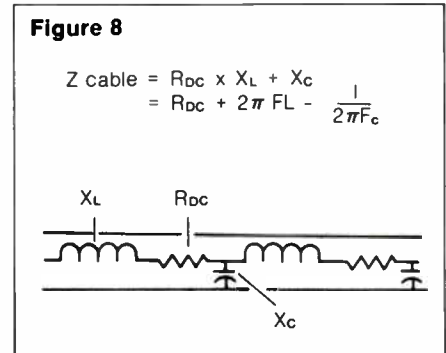
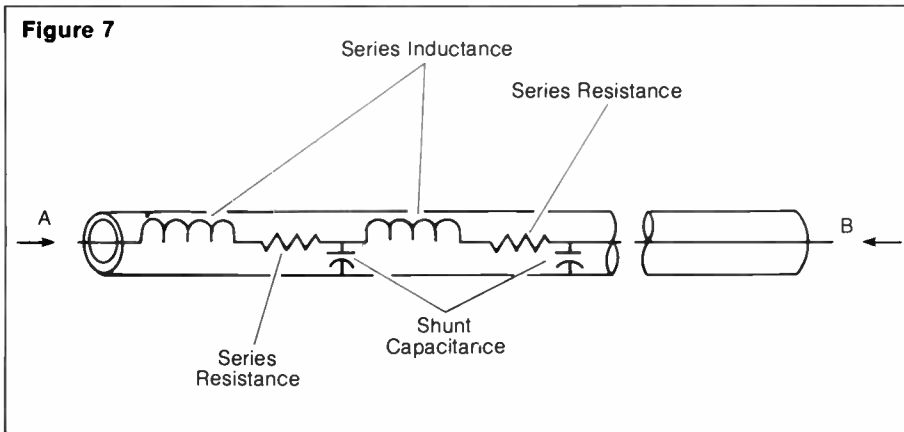

sured in "Farads") and the frequency. Figure 3 shows this in an equation.

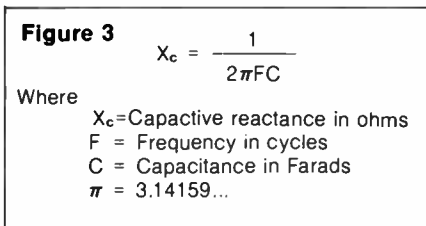

components of a cable can now be displayed as a capacitor with the shield at ground potential, the center conductor at some other potential, and the two separated by a dielectric, as in Figure 6.

When we charge this capacitor from some voltage source, remove the voltage source, and check the voltage at some time after the removal, we will find that there is some voltage still remaining, but a lesser quantity than that with which we started. This indicates that there was some leakage between one plate (the center conductor) and the other plate (the shield). This particular leakage is called dielectric loss.

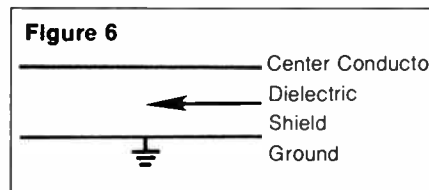

### Cable As an Inductance

The conventional symbol for an inductance is a coil. If it is straightened out into a single line, it will still have inductance because of the flow of current through it. In the cable, then, we have such a single line in our center conductor. When we go from point A to point B, the center conductor is a series inductance, but it is not a single series inductance, and therefore, in any transmission line going from point A to point B, there will be an infinite number of inductances. As shown before, the center conductor and outside shield, with the dielectric material between them, will form a capacitor. This capacitor is a shunting capacitor from center conductor to ground. Hence, we can add to our electrical equivalent of a piece of coaxial cable a series of shunting capacitors from the center conductor to ground, so that the representative picture becomes a capacitor at one end of a

cable followed by an inductance, another shunting capacitor, another inductance and so on to the shunting capacitor at the other end of the cable. Figure 7 illustrates this.

The impedance of the cable may now be determined from the equation and diagram in Figure 8.

To this point the math has been rather straightforward. Beyond what has been presented, things get somewhat more complicated and the derivation of the following from the foregoing requires an understanding of differential equations and is beyond the scope of this article. The characteristic impedance of a coaxial cable can be defined in the equation in Figure 9. Since these parameters are entirely dependent upon physical construction, the impedance of coaxial cable can also be expressed in the equation

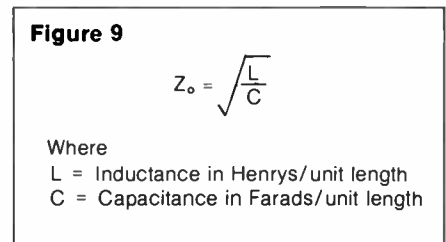

and diagram in Figure 10. As a result, coaxial cable of 75 ohms impedance may have various center conductor diameters and outside diameters.

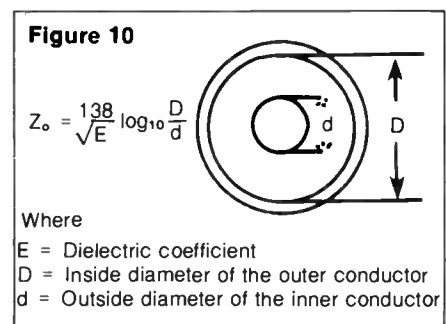

### Impedance

The AC counterpart to DC resistance is impedance. Impedance is denoted by the symbol  $Z$  and is equal in series circuits, to  $Z = \sqrt{R^2 + X_T^2}$ .

Figure 4 shows impedance in ohms and reactance in ohms for parallel circuits. Ohm's law applies to impedance as it does to resistance, as shown in Figure 5.

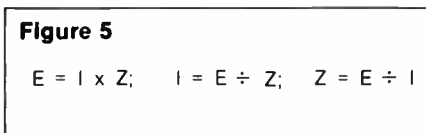
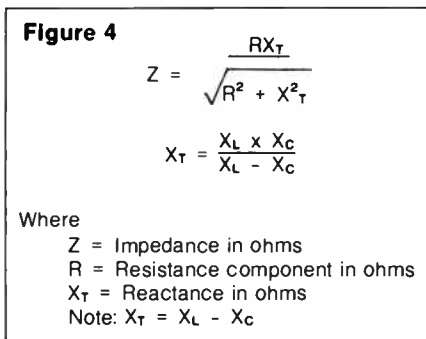

### Cable As a Capacitor

Since the outer shield is at ground potential and the center conductor is at some potential other than ground, the

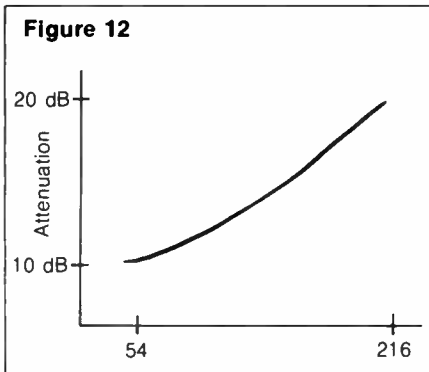

### Attenuation in Coaxial

As an RF signal propagates along a coaxial line, its level is reduced. This attenuation is a frequency-dependent phenomena. Since the attenuation is a function of frequency, the attenuation per length must be stated at the highest frequency at which the cable will be used. A given cable may be specified as 1.8dB/100ft at 216 MHz. The frequency dependence of the cable is expressed in the equations in Figure 11.

From the equations, the attenuation at any frequency can be determined. This frequency dependence causes system "tilt." In a "20dB" span, only the highest frequencies are attenuated by 20dB. In a 12-channel system, this would be Channel 13. The low frequency signals, traveling the same distance, are attenuated only 10dB or one-half as much, as shown in Figure 12.

### Temperature Effects

The previous section of information is correct at any given temperature. Cable attenuation is also a function of temperature. The attenuation change is .125%/°F. To see the effects of temperature on a system, assume 50 miles of trunk only. Trunk cable will typically have 1dB/100 ft. attenuation at 216 MHz. In this 50 miles of trunk there is 2640 dB of cable (Channel 13). (See calculations in Figure 13.)

**Figure 13**

$$50 \text{ mi.} \times \frac{5280 \text{ ft.}}{\text{mi}} \times 1 \frac{\text{dB}}{100 \text{ ft.}}$$

$$= 2640 \text{ dB of cable (Channel 13)}$$

If the mean temperature is 68°F, then the system should function well. But if the temperature rises to 100°F, the attenuation increases by:  $(100^\circ\text{F} - 68^\circ\text{F}) \times .125\% / ^\circ\text{F} = 4\%$ .  $4\% \times 2640\text{dB} = 105.6\text{dB}$  more attenuation (Channel 13) for a total

**Figure 11**

$$\Delta A_o = \sqrt{\frac{F_2}{F_1}}$$

Where  $\Delta A_o$  = Attenuation change factor  
 $F_1$  = Highest frequency  
 $F_2$  = Lowest frequency  
 (or frequency of interest)

If the cable is 1.8 dB/100 ft. at 216 MHz; what is the attenuation at 54 MHz?

$$\Delta A_o = \sqrt{\frac{F_2}{F_1}} = \sqrt{\frac{54}{216}} = \sqrt{\frac{1}{4}} = \sqrt{\frac{1}{2}}$$

Multiply  $\Delta A_o$  x by the given attenuation  
 Attenuation  $1.8 \text{ dB} \times \Delta A_o$  ( $\frac{1}{2}$ ) = .9 dB/100 ft.

**Table 1**

	Attenuation Channel 13	Attenuation on Channel 2	Tilt
100°F	2745 dB	1372.8 dB	1372.8 dB
68°F	2640 dB	1320 dB	1320 dB
0°F	2415.6 dB	1207.8 dB	1207.8 dB

of 2745.8dB. At Channel 2, the original attenuation was 1320dB and the same four percent change affects this attenuation. The Channel 2 change is 52.8 dB. (See Figure 14.)

As cold temperature is encountered, the attenuation decreases by the same .125%/°F. In the 50 mile system, the

change at a temperature of 0°F is  $(+68 - 0) \times .125\% = 8.5\%$ . (See Figure 15.)

But notice that not only did the total attenuation change dramatically; the slope or tilt changed as well. Table 1 shows this.

Note that the tilt changed 52.8dB from normal to hot and 112.2dB from normal to cold and a total change from cold to hot of 165dB.

These calculations can be reduced to smaller segments quite easily. In a system spaced at 20dB, the amplifiers will be about 2,000 ft. apart. The 50 mile trunk will have 131 amplifiers. To find the net effect per amplifier, divide each element calculated above by 131. So the net change per span is 2.5dB of attenuation and 1.25dB of tilt. This is illustrated by the diagram and table on Figure 16 on page 49.

This means that in hot weather, amplifier input levels will be lower than normal, and in cold weather, these input levels will be higher than normal. If the system were constant gain (all manual stations), then the output levels would fluctuate with the input levels. At the end of the small example in Figure 16 (three amplifiers), the output change would be 7.5 dB at Channel 13 and 3.75dB at Channel 2.

In the winter then, the system would be driven into cross modulation and triple beat, and in the summer, the system would have carrier to noise problems, unless the gain of each amplifier is adjusted to compensate for the cable changes. This is a rather laborious task as temperatures may vary sufficiently from daylight to dark to cause serious problems. Some means then needs to be discovered to compensate the system gain to temperature automatically; hence the AGC amplifier. But AGC at a single point only partially solves the problem. It

**Figure 14**

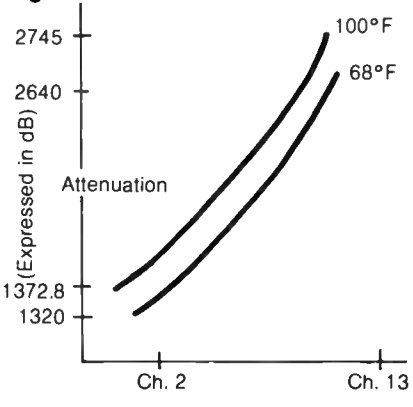

**Figure 15**

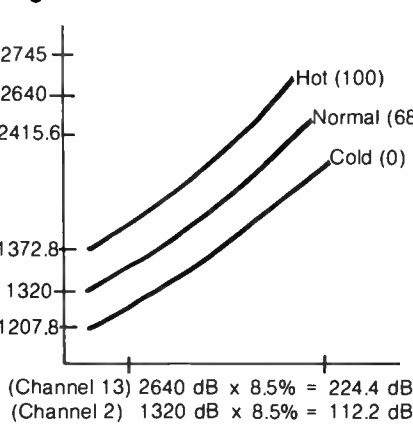

**Figure 16**

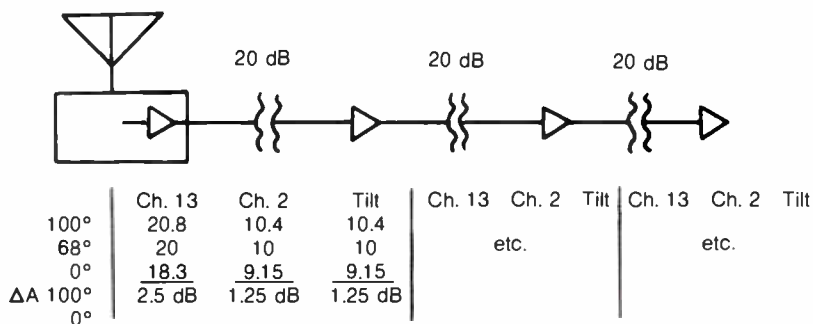

**Figure 17**

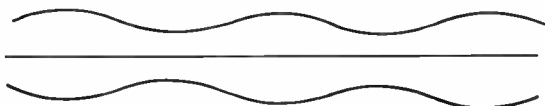

does nothing to change the slope. AGC alone without slope control only delays the buildup in terms of cascade length. Modern amplifiers utilize both automatic gain and automatic slope control circuitry.

**Periodicity**

If in any cable television transmission line, some type of discontinuity appears at regular intervals, a condition known as periodicity arises. A discontinuity can arise in a cable during manufacture if the cable machine causes a slight compression in the cable as in Figure 17. Since the dimensions of the cable have been changed at that point, the characteristic impedance is changed.

A discontinuity also occurs whenever an amplifier is inserted into the transmission line and also whenever a tap is inserted. Thus, any time there is any interruption of any sort in a transmission line, a discontinuity of characteristic impedance change (of some magnitude) occurs at the point of interruption as shown in Figure 18.

Due to the sudden change in characteristic impedance, some of the signal power in the transmission line is reflected. Reflected power creates what is known as standing waves along the transmission line.

If the discontinuities occur at regularly spaced intervals, then clearly, this distance between discontinuities is a half-wavelength for some frequency. Periodic discontinuities can also be caused by cracks in drip loop on regularly spaced poles, as illustrated in Figure 19.

Thus, for this frequency and for all integral (1,2,3,4. . .) multiples of this frequency, the standing waves caused by reflected power are in phase and, therefore, add. The result is that most of the power at these frequencies is reflected

and, therefore, any signals at these frequencies are greatly attenuated. If, for example, these discontinuities occurred at a distance which was half an electrical wavelength for television Channel 6, then Channel 6 could very well "mysteriously" disappear from a cable television system even before the first subscriber location was reached.

Periodicity can be prevented by careful inspection of all cable before installation, and by locating amplifiers and taps at random (rather than regular) distances from each other. Sweep testing of cable prior to installation will detect structural problems by means of bad return loss readings.

**Velocity of Propagation**

The electrical wavelength of any sinusoidal wave is the physical distance travelled by an increment of electromagnetic energy during the time taken to complete one sinusoidal cycle. As frequency (cycles per second) increases, the time taken to complete one cycle decreases, and, therefore, the electrical wavelength decreases. Thus, the electrical wavelength (in feet) of a signal equals the velocity of the energy (in feet per second) divided by the signal frequency (in cycles per second). The velocity at which the energy travels is known as the "velocity of propagation."

In free space, the velocity of propagation for electromagnetic energy is the speed of light. In all other transmitting media, the velocity of propagation is less than the speed of light. Clearly, as the velocity of propagation decreases, the electrical wavelength decreases.

The velocity of propagation (Vp) is different for different types of transmission lines. Vp is expressed as a percentage of the velocity of light. Thus, for free

**Figure 18**

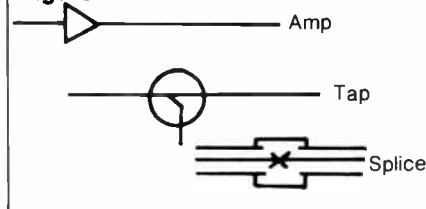

**Figure 19**

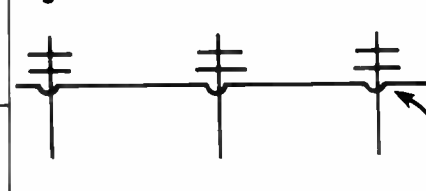

space Vp is 100 percent, Vp for twinlead is considerably less, and Vp for coaxial cable is considerably less still. The calculations for wavelength in free and cable space is shown in Figure 20 on page 50; typical Vp for various types of cable is presented in Table 2 below.

**Table 2**

Cable	Dielectric	Vp
RG 59	.66	Polyethylene
RG 59	≈ .84	Polystyrene
RG 6	.66	Polyethylene
RG 11	.66	Polyethylene
.5 dia	≈ .84	Polystyrene
.5 dia	≈ .87+	Gas injected
.5 dia	≈ .90	Air dilution

**Cable Care**

It is very important to maintain care in the construction of a cable system. As an example, during the course of construction, if a cable is put along the ground and a vehicle runs over the cable, the bottom of the cable will be flattened out. Thereupon, the space from center conductor to the outside shield will be changed, which will change the C without changing the L, and, therefore, will change the 75-ohm impedance. Kinking the cable will cause distance from center conductor to outside shield will be reduced and the capacity will change without any change in L. Therefore, the impedance will change. Figure 21 on page 50 shows just a few of the things that can happen to a cable during installation.

The presence of moisture in the cable is one of the things that the entire cable industry fights. The presence of moisture inside the cable will actually change the K (dielectric constant) of the cable and, therefore, the capacity will change once

# “At last, an MDS Downconverter designed and built, from the inside out, for system profitability.”

Jack Schnabel  
Sales Manager  
TEST, Inc.

## Introducing TEST's Model 1K, the new, state-of-the-art, crystal-controlled microwave receiver.

### Precision design, inside and out

Superb performance and dependability are the result of circuitry expressly designed to maximize the performance of each part, as well as the unit itself. These correctly applied, state-of-the-art components yield stable operation even in severe climatic conditions.

### Moisture locked out

Long, trouble-free life is assured because moisture is positively locked out by the weatherproof gasket seals and the humidity-proof metal housing.

### No detail overlooked

Even the connectors have been designed as an integral part of the housing. They provide exceptional R.F. and environmental characteristics.

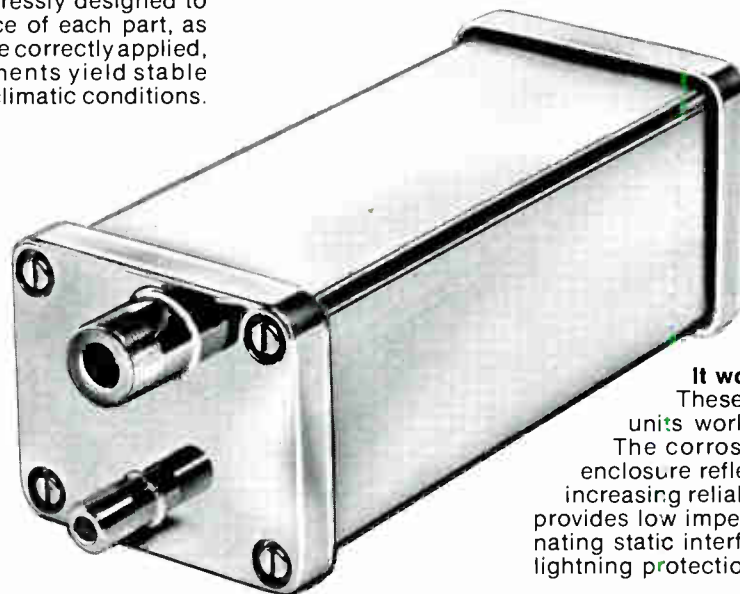

### Each Model 1K is ready to install and includes:

- **Matched power supply.** Mounted back-of-set, its design provides protection against man-made and lightning induced power line surges. An easily replaced fuse protects your investment and income.
- **Mounting hardware.** Installation is quick and simple with the unique, pre-attached, high-strength bracket. It securely attaches the unit to the mast with simple hardware.
- **Complete installation instructions.** Your installation personnel are provided a detailed instruction sheet with every unit.

TEST sells only to bonafide operators and their contractors.

### Exclusive: Channelizing filters

Compare this new, stable crystal-controlled microwave receiver to **any** you've seen. Only TEST has incorporated channelizing output filters that free these units from off-channel interference and unwanted spurious responses.

### Low-noise, high R.F. gain models available, too

Add more customers in weak signal areas using TEST's new low-noise, high R.F. gain models 10K, 20K and 30K. Sized the same as a 1K, these provide an extra 10dB, 20dB or 30dB of low noise R.F. preselector gain.

### It works as good as it looks

These highly-tooled, compact units work as good as they look. The corrosion-resistant, all-metal enclosure reflects environmental heat, increasing reliability and stability. It also provides low impedance grounding, eliminating static interference while increasing lightning protection.

### Production runs are now being scheduled.

Call me today at (213) 989-4535, or send the coupon below for more information on the complete TEST line of microwave receiving equipment.



TEST / Tanner Electronic Systems Technology, Inc.  
16130 Stagg Street / Van Nuys, California 91409

YES. Please give me more information regarding the new line of TEST Downconvertors.

Name: \_\_\_\_\_ Title: \_\_\_\_\_

Company: \_\_\_\_\_

Street Address: \_\_\_\_\_

City: \_\_\_\_\_ State: \_\_\_\_\_ Zip: \_\_\_\_\_

Telephone: (\_\_\_\_\_) \_\_\_\_\_

**Figure 20**

$$\text{Wavelength in free space (ft.)} = \frac{984}{f \text{ MHz}}$$

$$\text{Wavelength in cable (ft.)} = \frac{984 (V_p)}{f \text{ MHz}}$$

again without any change in L. Again, this will change the impedance. It is apparent, then, that it is quite easy to change the C of the cable but very difficult to change its L. Therefore the relationship between the L and the C must be maintained in order not to upset the 75 ohm impedance. This becomes important because every time a mismatch in the cable occurs, some of the power which should continue down the lines does not, but instead returns from the point of mismatch in the direction from which it came. The returning signal at point of mismatch is defined by the term "return loss." As an example if the return loss from the mismatch were 20 dB, this could indicate that the signal being reversed in direction and returning from whence it came, would be 20 dB below the signal that arrived at the mismatch in the first place. It becomes obvious, then, that the amount of signal available to continue down the line must be reduced by the amount of the signal reflected. The presence of mismatches, then, robs a system of signal power. It may be necessary to add additional amplifiers in order to make up for this accumulation of mismatch losses. This is a minor problem compared to the problem which arises because of the presence of two mismatches in a single length of cable.

**Figure 23**

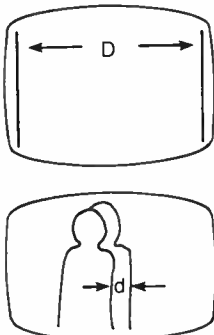

**Figure 21**

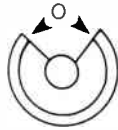

= Squirrels ate it!  
 $Z_o = \Delta Z \times Z_o = Z_o(0.03 \theta^2)$

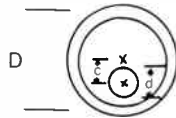

= Too sharp bend or faulty dielectric

$$z_o = \frac{60}{\sqrt{E}} \text{ Cosh}^{-1} \frac{1}{2} \left[ \frac{D}{d} + \frac{d}{D} - \left( \frac{4C^2}{dD} \right) \right]$$



= Bad lashing machine! Car ran over it!  
 Bad spool handling  
 $Z_o = ?$

**Ghosts**

If a cable has more than one mismatch or if the mismatch is physically close to even a moderate match, ghosts can be generated. Consider the example in Figure 22.

A TV set and calculator can provide an approximate space for the ghost producing discontinuities. First, measure the raster length on a TV set; call the distance "D". Then measure the distance from the desired image to the ghost. Call this distance "d". These measurements are shown in Figure 23.

Since the horizontal rate for colorcast is 15,734 KHz, the line time is 63.35 s. The retrace is about 11 s, so the active time per line is 52.55  $\mu$ s or so. Measuring the "d" and "D" distances and solving the following equation gives the ghost round trip time! Figure 24 shows the calculations.

**Figure 24**

$$\frac{D}{d} = \frac{52.55}{x} \text{ or } x = \frac{d}{D} \times 52.55$$

$x = \text{time in } \mu\text{s.}$

To convert to distance the signal velocity in cable must be known. The signal propagates at 186,292 mi/sec. in free space, and at less velocity in cable. The units of mi/sec. are somewhat unwieldy. Convert it to ft./s as in Figure 25.

**Figure 22**

16 dB match      Tap (B) match 6 dB

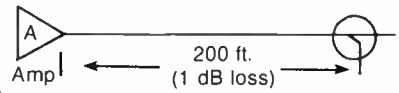

Vo → Signal goes down cable      Vo-1  
 ← Vo-7

Signal loses 6 dB and starts back to origin  
 Vo-8 →      Vo-24

Signal loses 16 dB in output match and starts back to tap 24 dB down

Vo-25 - signal arrives back at the tap 24 dB below the original signal and delayed in time.

**Figure 25**

$$\frac{186,292 \text{ mi}}{1 \text{ sec}} \times \frac{5280 \text{ ft}}{1} \times \frac{1 \text{ sec}}{1,000,000 \mu\text{s}} = \frac{983.62 \text{ ft}}{\mu\text{s}}$$

To find the speed in cable, multiply by the velocity of propagation (Vp) of the cable the system uses, as in Figure 26.

Multiply the number of feet the signal travels and the amount of time for the ghost (round trip) numbers and divide by 2 to get the one-way distance. In the example, if the screen were 20 inches wide and the ghost image spaced 1/6-inch, the distance in cable would be 200 feet. Once the distance is found, consult the system maps for devices which are spaced the appropriate distance apart. Remember, ghosts do not propagate "upstream around amplifiers, only downstream." This system yields approximations only and should not be considered as exact.

**Figure 26**

$$V_p = .94 \times \text{speed} = .94 \times 983.62 = 924.60 \frac{\text{Ft}}{\mu\text{s}} \text{ in cable}$$

*In February, Raleigh B. Stelle III was promoted to vice president at Texscan Corporation. In his new post, he continues to act as national and international sales manager.*



Now you can find all your CATV test equipment with one phone call. Because Wavetek and Mid State have joined forces and are at the same place on your dial.

For a catalog describing our complete line of CATV instrumentation, call us toll-free at 800-428-4424. In Indiana (317) 787-3332. Or write Wavetek/Mid State,

P.O. Box 190, Beech Grove, Indiana 46107. TWX (810) 341-3226.

**WAVETEK®**  
**MID STATE**

# A new line of CATV instruments that's bigger and better than Wavetek or Midstate?

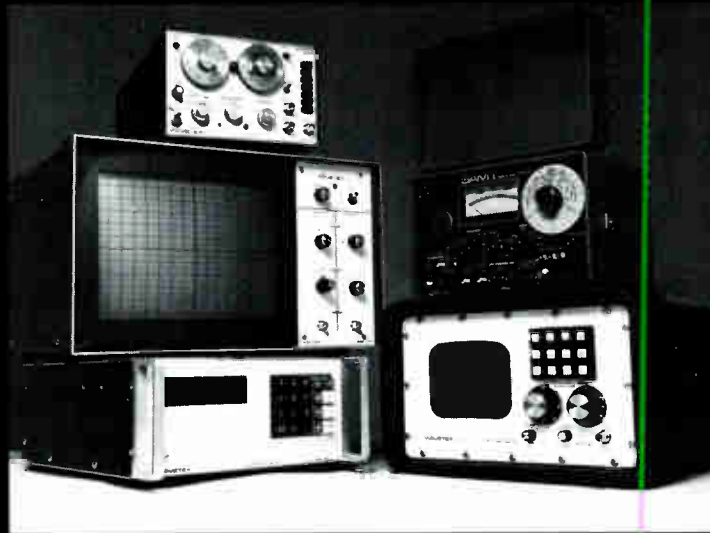

# Four Major Milestones in CATV Amplifiers.



## From TRW, first.

First transistors made and characterized especially for CATV amplifiers.

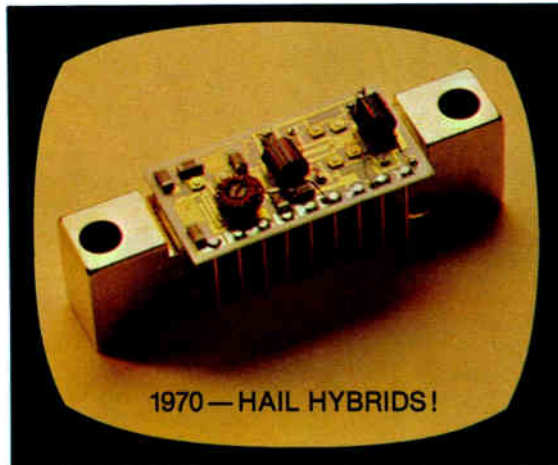

## TRW does it first. Again.

First hybrids for CATV. Elimination of interconnects provides inherent increase in reliability, ease of field repairs. Improved performance over discrete amplifiers.



## And TRW is first. Again.

First hybrids with all gold systems, the optimum for ruggedness and reliability. Gold die with ballasting resistors and fine geometry has dramatically improved the performance.



## Year after year, TRW is the leader. Once again.

In 1980, we introduced extended band width.  
In 1981, TRW R&D will present still another major milestone.

**TRW** RF SEMICONDUCTORS  
An Electronic Components Division of TRW Inc.

# Watching Out For Poorly Plated Passives

By George Acker, president, Aberdeen Company.

**A**lmost all construction hardware meets electrical code and specifications and can be accepted as standard by the cable industry. The principal exceptions to this are installation materials, which are not required to meet industry standards. A series of tests run recently

by Aberdeen Company has revealed how shoddy and worthless some hookup and installation materials on the market are.

Unfortunately, some cable operators seldom question or test the quality of installation materials. Unwary operators or operators looking to cut corners can easily end up with installation materials like the ones pictured in this article, leading to a wide range of service delivery problems.

Figure 1 shows a corroded ground rod

( $\frac{3}{8}$ -inch by four feet) commonly used for house installations. Fortunately, this ground rod was never installed. It became badly rusted just lying in a warehouse. This is a good representation of Type 3 rods, the worst rods on the market. First, the plating is so thin it has little or no corrosion resistance and no copper conductivity for grounding. Second, the steel clamp is installed before plating. Consequently, neither the clamp nor the rod are plated completely. The bare metal

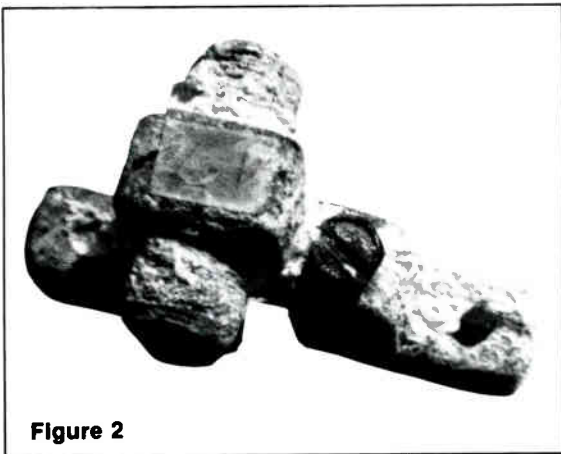

Figure 2

**Inferior ground blocks or clamps cannot withstand a salt spray test.**

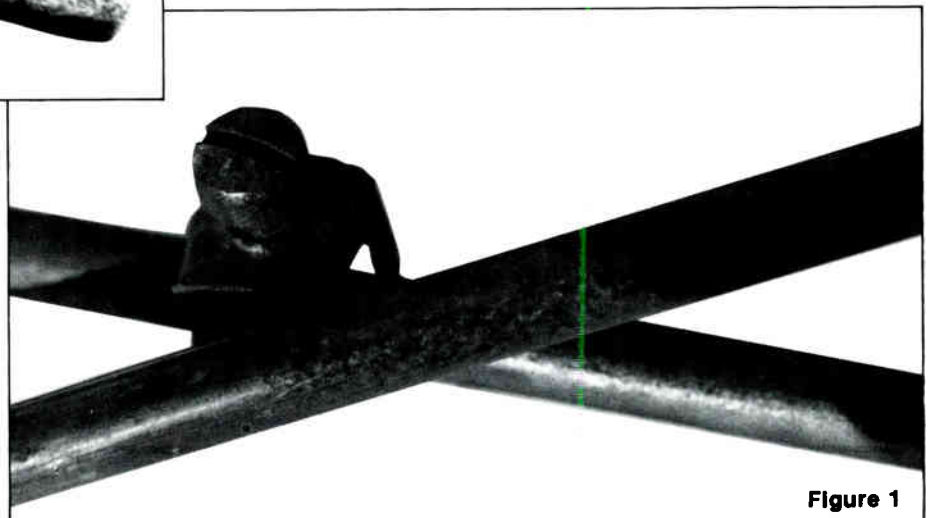

Figure 1

**Type 3 rods sometimes rust just lying in a warehouse.**



Figure 3

A salt spray test made short work of this imported span clamp and tap bracket.



Figure 4

invites quick deterioration.

A Type 2 rod is completely plated with approximately three mils of copper. The clamp used is solid brass, making it acceptable for ground installation. It is moderately priced and approved and used by many companies.

Type 1 rods are fully plated with at least ten mils of copper. This rod has a solid brass clamp and is recommended as the best grounding rod for most house connections. It is slightly higher priced but measurably better.

Figure 2 on page 53 shows ground blocks or clamps that have been subjected to a salt spray test for two weeks. The inferior or cheap die-cast metal turned to powder. Not only is the clamp destroyed, but ground contact is lost. Most imported blocks and some domestic blocks have failed this corrosion test. The only blocks or clamps worth buying are made of high quality aluminum or stainless steel.

The salt spray test applied to the imported span clamp and tap bracket in Figures 3 and 4 illustrates two pronounced failures. A cheap aluminum alloy starts to deteriorate and will soon weaken the clamp. The finish on the steel bolt is inferior and not up to U.S. standards. The nut and threads show a great deal of oxidation. Purchasing these is a poor way to cut costs.

## Own your own satellite receiving system

And pick up television programming from the communications satellites. See all network and cable shows as well as uncut movies, sports events not on commercial TV, and much more.



MID-AMERICA VIDEO  
P.O. Box 511 • (501) 753-3555  
North Little Rock, AR 72115



## TRIPLE CROWN ELECTRONICS INC.



### MODEL HE-P SIGNAL PROCESSOR

The HE Series of processors and modulators was designed to meet today's needs of small systems for high quality processing and adjacent channel loading at an economical price. All frequency conversions are crystal controlled and have IF accessibility. Input signal range: baseband or 5-900 MHz. Output signal range 5-300 MHz.

Write or call: 42, RACINE ROAD,  
REXDALE, ONTARIO, M9W 2Z3.  
Tel. (416) 743-1481

*We specialize in being active!*

# Scientific-Atlanta introduces the cable system you can talk to



Want to check on signal levels and power throughout your entire system? Just ask the system.

**H**ow are you doing?" asked the Headend. "I'm doing fine," the Trunk Amplifier replied.

"Are you getting enough power?"

"No problem."

"Signal strength OK?"

"Fine."

"Anything else you want to tell me?"

"Not right now."

At last, you can monitor signal levels and power throughout the entire trunk system, from headend to neighborhood bridging station, on a 24-hour basis.

The Scientific-Atlanta Series 6500 Status Monitoring System literally opens up an on-going dialog with your cable system.

You can interrogate, give reverse bridger switching commands, and evaluate the replies of as many as 2048 amplifier status transponders.

When there's a problem, the system provides a visual and audio alarm to your headend, hub or office. It identifies the failure, and tells you exactly where it's located.

And unlike the bulb in the Christmas lights, you don't have to test the whole system for trouble. You can dispatch service crews directly to the problem area.

## IT STARTS WITH OUR COMMUNICATIONS CONTROL UNIT

The communications control unit is installed at your headend or any central distribution point. Then, amplifier

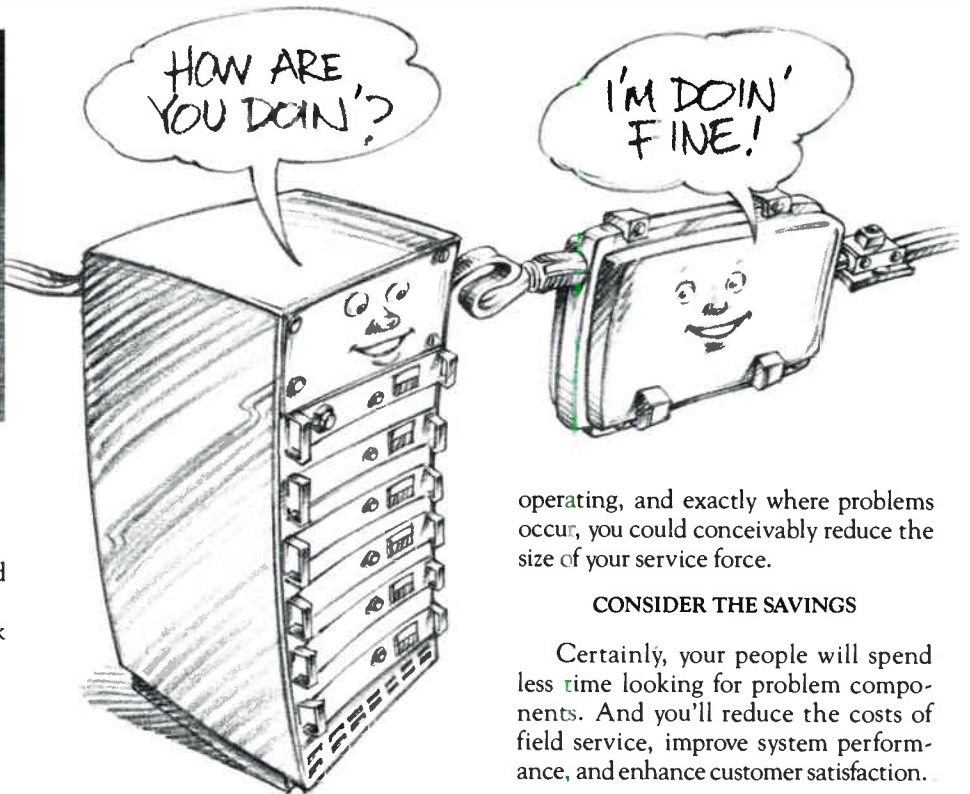

status transponder modules are installed in the trunk amplifier housings.

The control unit (combining CRT terminal, microprocessor, message transmitter and receiver) interrogates and evaluates replies from each status transponder, and sends reverse bridger switching commands.

Reverse bridger switching means that specific reverse feeders can be connected or disconnected so you can identify the particular trunk station involved. (RBS also reduces reverse system noise by turning off all feeders not being used at that time.)

Monitoring continues 24 hours a day. When acceptable signal or power levels aren't met, the alarm sounds and vital information is displayed simultaneously.

A glance at the CRT screen identifies the problem amplifier and explains the fault. Your operator can then take the appropriate action to correct the situation.

And that's the basic system. It works now, and can easily be expanded with plug-in memory boards, hardcopy printer, even a floppy disc system. Also, by knowing just how your system is

operating, and exactly where problems occur, you could conceivably reduce the size of your service force.

## CONSIDER THE SAVINGS

Certainly, your people will spend less time looking for problem components. And you'll reduce the costs of field service, improve system performance, and enhance customer satisfaction.

## READY NOW FOR OUR 300 THROUGH 400 MHz SYSTEMS

The 6500 Status Monitoring System is technologically advanced, yet simple to understand and use. It's available now on our 300 through 400 megahertz systems—which we're currently supplying in quantity for cable systems across the country.

For more information, contact Solomon Webb at Scientific-Atlanta, (404) 441-4111. Or send this coupon.

**Scientific Atlanta** CED 5/81

4386 Park Drive, P.O. Box 105027,  
DEPT A-R Atlanta, Georgia 30348

- Please send details on your  
6500 Status Monitoring System  
 Other cable television products

NAME \_\_\_\_\_

TITLE \_\_\_\_\_

COMPANY \_\_\_\_\_

ADDRESS \_\_\_\_\_

CITY \_\_\_\_\_

STATE \_\_\_\_\_ ZIP \_\_\_\_\_

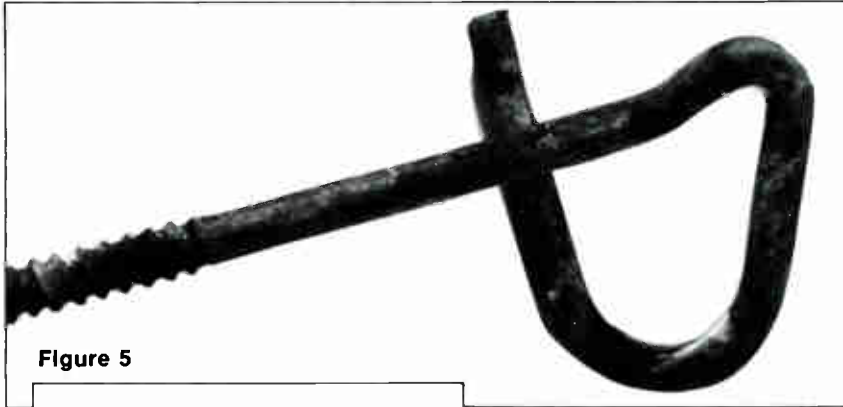

Figure 5

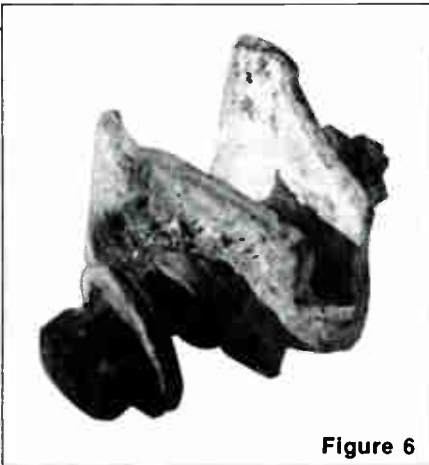

Figure 6

**Imported or domestic hooks with inadequate plating cannot resist corrosion.**

**Inferior lashing wire clamps will not last the required life of overhead construction.**

P-hooks, such as the one in Figure 5, don't look good or last when they rust. Imported or domestic hooks with inadequate plating cannot resist corrosion.

Figure 6 illustrates the cause of a potential problem with lashing wire clamps. The finish on these imported parts shows rust on the stud, nuts, washer and clamp. None will last the required life of overhead construction. The stud bolt has a low breaking strength and can separate and fail when first installed or after short usage. A broken lashing wire clamp means loose wire and cable.

Cable company engineers and purchasing agents should be acquainted with the qualifications of quality attachments. They are made by several U.S. companies and wisely identified by brand. Accept no cheap substitutes by supplier, contractor or installer.

*George Acker has supplied equipment to the cable television industry since 1956, when he purchased the Lake Arrowhead cable system in Crestline, California. Since then, Acker has been a part owner or operator of eight cable systems.*

**LEADER**  
Instruments Corporation

Call or write for your free full line catalog.  
Available now from CWY!

405 N. Earl Avenue  
Lafayette, Indiana 47904

Call Toll Free 1-800-428-7596  
Indiana 1-800-382-7526

See us at the  
NCTA—Booth 770

Only \$4,225<sup>00</sup>

**"MARQUEE"**  
MODEL CG-800

DAY	TIME	DATE
WED	12:48:12	9/28

TEMP	HI	LO	BARO
72	76	64	29.888

WIND	FROM	GUSTS	CHILL
17	WSW	34	70

BESTON ELECTRONICS, INC.  
OLATHE, KANSAS

WITH A SLIGHT CHANCE OF THUNDERSH

COMMERCIAL STATE BANK  
309 BROAD STREET  
442-2000  
YOUR HOME TOWN INDEPENDENT BANK

LOANS FOR ANY GOOD REASON  
AUTO - PERSONAL - BUSINESS  
HOME IMPROVEMENT - TRAVEL

DAY	TIME	DATE
WED	12:48:12	9/28

HE HIGH TOMORROW IN THE MID TO U

Crawl line is standard with keyboard entry, optionally interfaced to NOAA

ONE PAGE LIKE THIS!  
THREE PAGES LIKE THIS!  
(with 8 line messages on each page. Expanded to 16 pages for only \$3800)

**COLOR DIGITAL WEATHER / MESSAGE**

AFFORDABLE BY DESIGN

Only \$4,225<sup>00</sup> COMPLETE: Including the cost of a factory wired and tested HEATHKIT WEATHER COMPUTER!

BEI has interfaced the CG-800 "Marquee" to the Heathkit digital weather computer for a low cost color digital weather and message channel.

CHECK THESE STANDARD FEATURES:

- Keyboard
- Four message pages
- Crawl line with 1000 characters
- RS-170 Color Sync System
- Color background generator
- Automatic centering
- Page by page display time
- Random page display
- AND MORE!

See Us At The  
NCTA—Booth #601

P.O. Box 106A - Olathe, Kansas 66061  
Toll Free 1-800-255-6226  
in Kansas 913-764-1900  
TWX 910-749-6401

# MICROCEPTOR™

## MDS ANTENNA

WITH INTEGRATED DOWN CONVERTER

by **CONIFER®**

(FORMERLY NAMED WINEGARD INDUSTRIES)

This anodized reflector antenna with factory preassembled crystal controlled down converter results in excellent match and a substantial savings in installation labor.

The antenna is available with our standard down converter (MDPA) or with our new high gain, low noise converter (MDPA-LN). See specifications below. You also have a choice of vertical or horizontal polarization.

Microceptor is small and compact... about the size of this page... has low wind resistance and is unobtrusive on the home.

### BASIC SPECIFICATIONS

	MDPA	MDPA-LN
Antenna Gain	15dBi	15dBi
Antenna VSWR	1.1:1 max.	1.1:1 max.
Converter Gain	22.5dB typical	32dB typical
Converter Noise Fig.	4.2dB typical	2.5dB typical

### THE ORIGINAL PARACEPTOR™\*

America's most copied MDS antenna. Available with 18dBi gain or 21dBi gain. Preassembled and weatherproofed. Unique design has greater signal capture area.

### CONIFER'S DOWN CONVERTER

Crystal controlled and designed for use with Paraceptor or other MDS antennas. Proven reliable in tens of thousands of installations. 100% tested. Competitively priced. Choice of standard or high gain, low noise models.

\*Patents Pending



**CONIFER®**  
CONIFER CORPORATION

P.O. BOX 832, BURLINGTON, IA. 52601

CALL 319-752-3607



"Out of Sync" is a service provided by **Communications Engineering Digest** to our subscribers. We will help you locate answers to all technical questions submitted. On urgent problems, or problems lacking in essential detail, **CED** may respond to you by phone prior to publication.

Names and locations will not be published without written authorization. Send your questions, and possible solutions, to "Out of Sync," **Communications Engineering Digest**, Titsch Publishing, Inc., P.O. Box 5400-TA, Denver, Colorado 80217.

**Q** I keep seeing "diplex filters" listed as part of the optional accessories for amplifiers. What do they really do?

**A** Diplex filters are frequency selective splitters. They are used at the input and output of amplifiers which are designed to transport signals in both forward and reverse directions at the same time. And, of course, like almost any other splitter, when turned backward, they may be used as combiners.

They are made with three ports: one input and two outputs. The input is called the common port; one of the output ports passes only those frequencies below 50 MHz; the other output port passes only those frequencies above 50 MHz. (See the diagram below.)

Diplex filters used in midsplit systems may have other passband frequencies, such as 108 MHz or 174 MHz.

**Q** All our present amplifiers are powered by 30 volt supplies but the new ones all specify 60 volt powering. Why is this change being made?

**A** At one time, all solid state amplifiers used 30 volt powering. This was established as the standard. I am not sure who first made the decision to use 30 volts as the standard, or why, but I have heard that it had something to do with the amount of voltage which could be legally carried on a communications

cable. I don't know if this is correct, but I do know that 60 volt powering is more efficient.

Almost twice as many amplifiers can be powered from a single 60 volt power supply as from one producing 30 volts. This is due to the reduced voltage drop (per Ohm's Law) since increased voltage means reduced current through a fixed resistance or load. At first thought, it might seem that doubling the voltage would double the number of amplifiers which could be powered. This is not true since all the amplifiers are not at the same distance from the power supply. The increased lengths of cable mean increased DC loop resistance and, consequently, a reduction in the number of amplifiers which will receive proper voltage.

To get back to your question, fewer power supplies mean less cost to purchase and operate the supplies and less maintenance costs. Also, many of the newer amplifiers, especially if they are equipped for two-way operation, require more power to operate properly. This means that higher voltages are required to meet the power consumption of the new amplifiers.

**Q** Can you tell me what the term "Maximum Power Transfer Theorem" really means?

**A** Very simply stated, it means those conditions which exist whereby the maximum power from a source is applied to, and accepted by, a load. In most instances, at least in cable television, for maximum power transfer to occur requires perfect impedance matching of the source, the load, and the transmission line which connects them. If any of the source power is reflected due to impedance mismatch, maximum power transfer is not being effected.

The Maximum Power Transfer Theorem is:

- If the load of any circuit is purely resistive, maximum power transfer will be effected when the load resistance exactly matches the source impedance;
- Maximum power may also be transferred when the load is any impedance which is a conjugate of the source impedance. If source and load reactances are equal and opposite, they will cancel. If the remaining load resistance is equal to the source resistance, maximum power transfer will occur.

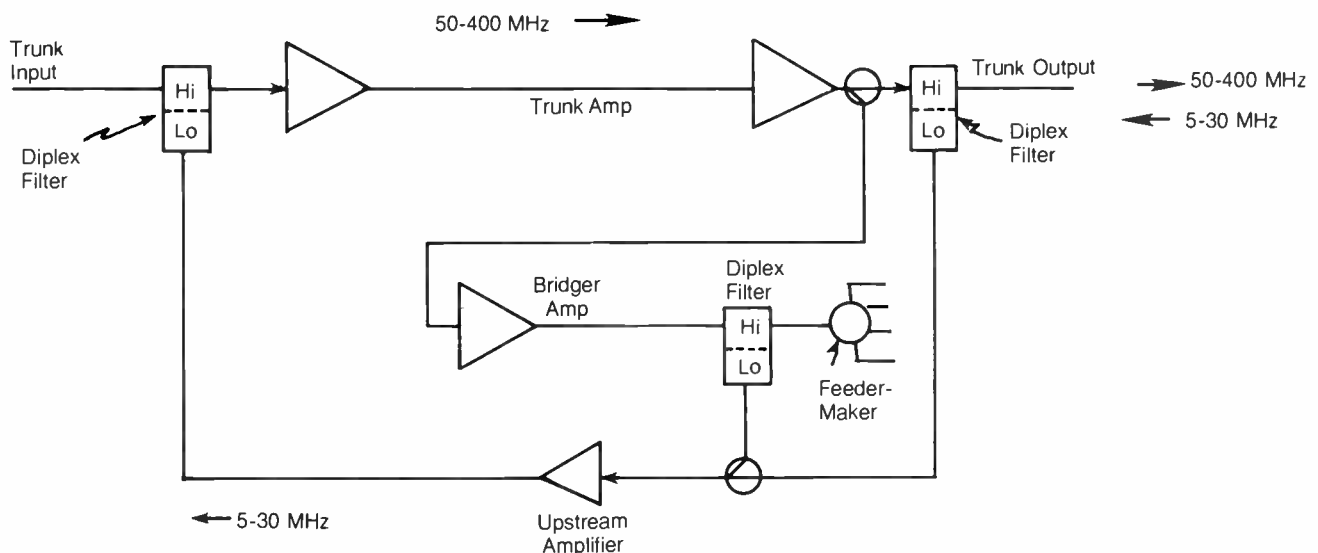



# The Sylvania 400 MHz line. The signal must go through.

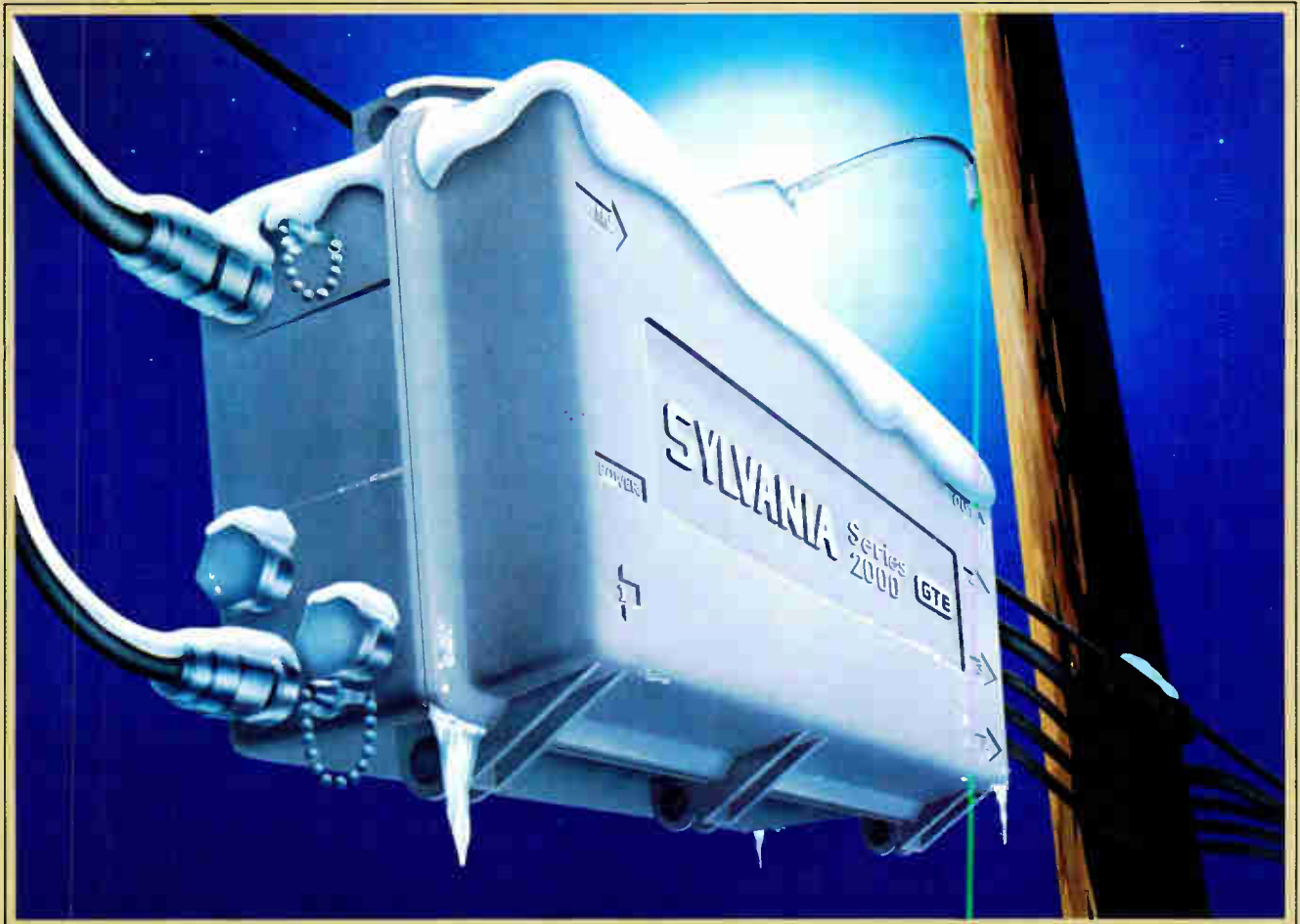

Through rain and snow and sleet and the worst electrical storms, Sylvania amplifiers will deliver your signal.

Whether it's 300 MHz or the new 330 MHz and 400 MHz line, our amplifier stations are made to take a beating from Mother Nature—and come up winners.

If lightning strikes, you're safe. Our Amplifier Stations are equipped with extremely fast acting surge protection devices. What's more, our accurate level and slope control maintains stable output through summer heat and winter cold.

The corrosion-resistant, diecast aluminum housing with a unique, single metal-rubber gasket keeps the weather outside, and the efficient thermal design insures cool and reliable operation inside.

You can't take chances on equipment that will cut off your customers in mid-program. That's why you need Sylvania. We've put our reputation for quality on the line, a reputation that's been standing up to the elements since 1970.

Our new manufacturing plant, a 400 per cent increase in staff and computerized customer services all help to make sure that you get reliable Sylvania products when you want them.

For complete details, contact your local Sylvania CATV Transmission Systems sales office. Or phone toll free 800-351-2345 within the continental U.S., except Texas. From Alaska, Hawaii and Texas, call (915) 591-3555 collect.

We'll come through for you.

Visit us in Booth 451  
at the NCTA Show.

**SYLVANIA**

CATV  
Transmission Systems

**GTE**

# 8 out of 10 video FM relay systems get from here



**MA-12X:** Compact, low cost  19" rack-mountable with built-in 115 VAC power supplies  audio and video S/N typically over 60 dB  compatible with PAC-6X modulators and demodulators.

**MA-12G:** Superior performance  high power transmitter output (+27 dBm)  optional Fail Soft 2W (+33 dBm) ADA  19" rack-mountable.

Both feature 12.7 to 13.2 CARS Band operation  PSIT and common carrier frequencies around 12 GHz  40 channel CARS Band capability  available in 12.5, 25, or 50 MHz frequency plans.

**AC POWER SUPPLY:** 115 VAC  high reliability for commercial AC lines  optional DC power supply available for remote operation.

MAC sales offices located in San Francisco • Denver • Dallas • Minneapolis • Atlanta • Burlington • Toronto • London.



# to there with our microwave technology.

See Us At The NCTA  
Show Booth #652

The further away you have to send programming, the more costs cut into your profit picture. MAC's economic, state-of-the-art FM microwave systems turn marginal service areas into profit makers. With cost-effective systems that relay programming over long distances to reach remote communities. And reliably retrieve signals from sub-heads and remote earth stations for distribution throughout a cable system.

MAC can deliver the FM advantage of superior picture quality in a variety of configurations. The right system—at the right price—to meet your growing needs. For example, our MA-12X receiver and transmitter make the

backhauling of signals from remote sub-heads a practical alternative to cable or AM. When greater performance and power is required, our MA-12G system is perfect for handling multiple power splits and multihop/long haul relays.

Technology, reliability and economy are the obvious reasons why CATV operators have made MAC the leader in video FM microwave applications. What may not be so obvious are the benefits of one-supplier accountability. One phone call is all it takes to get you fast service—24 hours a day, 7 days a week, anywhere in the country.

The next time you have any re-

mote distribution problems, speak to the experts who can help you put together a complete FM microwave system including antennas, towers and installation. You can count on MAC technology to bridge the distance between you and your subscribers. Call Duke Brown at (617) 272-3100. 63 Third Avenue, Burlington, Mass. 01803.

 Microwave Associates  
Communications

  
A  
COMPANY

# CED, Pass It On



Make sure others in your company are getting the latest technical information in the broadband industry. Pass this issue of CED along to them, or better still, get subscriptions for them by simply calling or writing our circulation department.

"Please refer to the subscription order card on page 67."

See us at TPI's Booth 1190 at the NCTA.

## **CED**

**Titsch Publishing Inc.  
P.O. Box 2500 TA  
Denver, Colorado 80217  
(303) 573-1433**



## Canada Authorizes Fiber Optics Experiment

OTTAWA, ONTARIO—The Canadian minister of communications has signed an agreement that authorizes the experimental provision of advanced fiber optics communications systems in the rural communities of Elie and St. Eustache, both about 30 miles from Winnipeg, Manitoba.

The "memorandum of agreement" signed by Minister Francis Fox covers the second phase of a project that will cost about \$9.5 million in total. The first phase of the project will cost \$6.3 million, and the second phase, \$3.2 million. The initial cost of the second phase, \$1.4 million, will be shared equally by the Canadian government and the Manitoba Telephone System. In addition, the government will match the \$900,000 that Infomart of Toronto contributed to the second phase for the purpose of including information and other electronic publishing services in the experiment.

The accord covers the cost of supplying and maintaining the digital data facilities needed to provide new service and 150 terminals for Telidon, the information service marketed by Infomart. Included in the new services will be the two-way Telidon programming which will be carried over the fiber optics cable that is being installed in the first phase of the project. In this initial phase, the optic fibers will carry telephone, cable television, and FM stereo services to 150 homes in the rural Canadian areas. Prior to the experiment, many of the 150 homes could only access party-line telephone service, according to project sources.

"The Manitoba communities will be a showcase of Canadian capability in high technology and new services," Fox said. "Furthermore, the project demonstrates what can be accomplished through federal-provincial cooperation and through government-industry cooperation."

The services to be offered in phase two are electronic messaging, home computing, and computer-aided learning designed for rural needs.

According to Fox, the objectives of the second phase are: to assess the potential of Telidon and other new services for rural areas of Canada; to determine the feasibility of incorporating a fiber optics system to improve communications services in rural areas; and to test services, carriers and equipment manufacturers on their ability to provide services to these regions.

The project is expected to begin in the

fall of 1981. The \$6.3 million cost of the first phase is being shared by the Canadian government (\$3.2 million), the Canadian Telephone Carriers Association, including the Manitoba Telephone System (\$2.5 million), and Northern Telecom (\$653,000), which will supply the fiber optics cable.

## Scientific-Atlanta Forms Company To Serve Mexico

ATLANTA, GEORGIA—Scientific-Atlanta has taken a large step toward expanding its international business with the formation of a company to serve the growing Mexican market for communications equipment. The new company, Digisat, S.A., will be 51 percent owned by Mexican investors and 49 percent owned by Scientific-Atlanta.

Initially, plans call for Digisat to market S-A's line of communications products. The company will then establish its own facilities in Mexico for the manufacture and assembly of satellite earth stations. According to Sidney Topol, chief executive officer of Scientific-Atlanta, S-A will provide the technical expertise and other assistance necessary to help Digisat get started.

Topol termed the formation of Digisat "a major step" in his company's international business development.

The Digisat seven-member board of directors will include Emilio Azcarraga Milmo and Miguel Aleman Velazco, leading representatives of the Mexican television industry; H. Allen Ecker, S-A's group vice president of telecommunications; and Topol.

## Australian Broadcasters Begin Antiope Trials

WASHINGTON, D.C.—Australia has joined the growing list of countries experimenting with Antiope, the French broadcast teletext system.

The Australian Broadcasting Commission has announced that it will start field trials of Antiope in late April or early May. The decision to turn to Antiope followed unsatisfactory trials of the British teletext system.

Australian broadcast officials said the British system, which was originally designed for use in UHF stations, has not tested well on the low-numbered VHF channels used. Data was distorted in its passage from the transmitter to the TV set, so that errors or omissions in the pages of information occurred, according to the Australian officials.

# Introducing

## The Seven Point Solution

Show Special  
Contact Your  
Distributor



- Light weight
- Designed for ALL foamed polyethylene cables from the original to third generation.
- Insulated for those activated splices.
- Color coded by sizes for quick easy identification.
- Replaceable blades as well as all components which make up the tool.
- A fast and efficient tool for the splicers.
- All sizes available and are drill adaptable DCT-412, DCT-500, DCT-625, DCT-750, DCT-875, and DCT-1000.

### The Cable Prep Dielectric Coring Tool

Available from your Cable Prep Distributor along with a Complete Line of Hex Crimp Tools.



**Ben Hughes Communication  
Products Co.**

P.O. Box AS  
Old Saybrook, CT 06475  
203/388-3559

# SELECT THE ROUTING SWITCHER YOU NEED



FROM ONE SOURCE...

## di-tech



**MODEL 5400**  
Matrix Sizes: 4x1, 8x2, 12x2,  
or 3-4x1 or 4x3, AFV



**MODEL 5412**  
Matrix 12x1 with dual audio.



**MODEL 5500**  
Matrix from 16x2 to 28x2, AFV



**MODEL 5800\***  
Video Assembly expandable beyond 20x15\*  
Audio Assembly expandable beyond 20x15\*



**MODEL 5815**  
Matrix 20x7, AFV with up to  
2 channels of audio per input.



**MODEL 5820**  
Matrix 20x6, AFV with up to  
3 channels of audio per input.

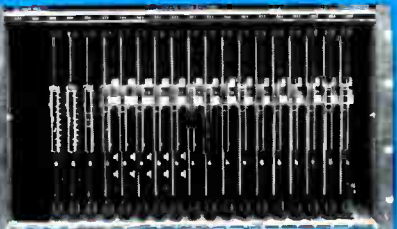
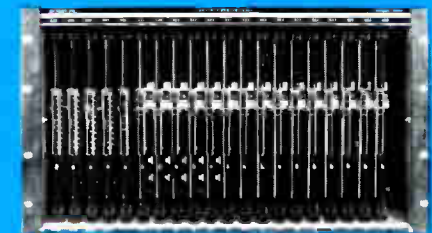

**MODEL 5840\***  
Video Assembly expandable beyond 40x15\*  
Audio Assembly expandable beyond 40x15\*

di-tech knows your needs aren't the same as every other broadcaster, so when we build equipment like audio and video routing switchers we build a whole line of them. That way you can select the exact matrix size and mechanical configuration that meets YOUR requirements, for audio only, video only or audio-follow-video with 1, 2 or 3 channels of audio per input. So why settle for less when you can select di-tech's surprisingly affordable equipment custom-tailored to your needs?

Whether the application be for a radio or television station, mobile vans, remotes or unattended sites, di-tech has equipment for you.

- VIDEO PRESENCE DETECTORS
- TOUCH TONE SYSTEMS
- A/V ROUTING SWITCHERS
- AUDIO MONITOR AMPLIFIERS
- TRANSMISSION LINE SUPERVISION SYSTEMS
- A/V PULSE DISTRIBUTION AMPLIFIERS
- COMPUTERIZED REAL-TIME WEEKLY EVENT CONTROLLERS.

Call or write for more information or our FREE catalog today!

**\*Both MODELS 5800 and 5840 feature:**

- up to 3 channels of audio per input within the same frame
- expandable inputs and outputs beyond the stated matrix
- audio only, video only or AFV; V.I. switching

Discover for yourself why industry leaders are switching to di-tech!

# di-tech

311 WYANDANCH AVENUE  
North Babylon, N.Y. 11704  
Tel. #(516) 643-4040

# New Products

## Headend

### Microwave Filter Markets TV Video/Aural Diplexer

**Microwave Filter** has introduced a TV video/aural diplexer. The model 3764-10 combines separate channel ten video (100W) inputs to a common output.

The unit is available for channels seven through 13. Connectors are type N (50 ohm), including termination jacks (terminations not supplied). Video-to-antenna loss is 0.6 dB at video carrier (193.25 MHz), increasing to 3.5 dB at 197.43 MHz.

Aural-to-antenna loss is less than 1.0 dB. Aural/video isolation is 30 dB.

For information, contact Emily Bostick, Microwave Filter Company, Inc., 6743 Kinne Street, East Syracuse, New York 13057; (800) 448-1666 or (315) 437-3953.

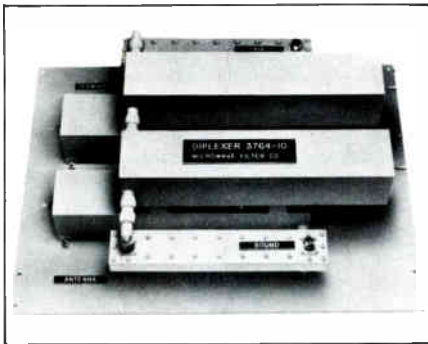

Microwave Filter is marketing the 3764-10 diplexer.

### Synchronous Communications Markets Interval Controller

**Synchronous Communications, Inc.**, has introduced the model PIC-1000 interval controller. The PIC-1000 has 1,000 intervals that can be programmed, via the front panel keyboard, to switch four Form "C" relay contact closures during a seven-day period. An interval is defined as a start and stop, time referenced function, that ranges from one minute to seven days.

In addition to the automatic mode of control, the four Form "C" relays can be manually controlled via the front panel keyboard, or remotely controlled by inputs to the back panel connector. The PIC-1000 has an optional battery backup power supply and an optional 19-inch rack mountable chassis.

For information, contact Synchronous Communications, Inc., 7180 Wooded Lake Drive, San Jose, California 95120; (408) 268-3714.

### Schaffner Manufactures EMI Filter Sticks

**Schaffner EMC** has introduced a line of EMI filter sticks designed to filter out RF line interference. Designated as the FR 300 series, the units clean up power line interference from 150 KHz to 300 MHz, providing up to 60 dB attenuation of undesired RF interference.

The EMI filter stick is ideal for mini- and microcomputers, digital instruments, microprocessors and video equipment that are highly susceptible to RF interference. In addition to a high performance line filter, the Schaffner EMI filter sticks contain an additional absorbing filter to eliminate radiated RF interference.

Each unit provides three outlets, automatic circuit breaker and illuminated power switch. They are rated at six amps. Models are available for either 120V or 220V.

For information, contact Schaffner EMC, 377 Route 17, Hasbrouck Heights, New Jersey 07604; (201) 343-7562.

## Line Equipment

### Texscan Develops "Vital Signs" Monitoring

**Texscan Corporation** has developed a computer-controlled system that reports the status of light parameters of amplifiers in a cable television system. Called "Vital Signs," the system is designed to provide speed in locating and correcting system malfunctions and outages and to give operators the ability to predict problems before they become serious.



The "Vital Signs" status monitoring system from Texscan Corporation.

Vital Signs is designed to interface with all vendors' amplifiers and to be an integral part of Theta-Com's T 300/400 series. In order to be monitored, each amplifier must be equipped with a monitor transponder.

Vital Signs offers a solution to return-path noise problems in two-way systems, particularly those with security features, by controlling, as well as monitoring, reverse-bridger switching. This feature reduces the amount of low frequency ingress since only one reverse path is "on line" at any instant of time, according to the company.

Each transponder module measures up to eight parameters continuously. Each of these modules has its own digital address and function code, which the operator can type into a keyboard. The PPI (processor plant interface) interrogator sends down the forward path a narrowband frequency modulated digital signal. This signal asks a specific transponder to send back a specific measurement. The transponder responds with a NBFM signal digitally coded on the return channel to the headend, where the results are printed on a CRT display. The system monitors each transponder location in turn.

For information, contact Texscan Corporation, 2446 North Shadeland Avenue, Indianapolis, Indiana 46219; (317) 357-8781.

## Power Supplies

### RMS Electronics Markets Standby Power Supplies

**RMS Electronics** is marketing the PS-SB30 and PS-SB60 standby power supplies. The units have as their primary source of power the Power-King™ ferro-resonant supply. The models have the following specifications: output voltage 30 V or 60 V (jumper selectable); output power, 720 VA; output frequency, 60 Hz ± two percent; efficiency, 80 percent; and regulation, ± 1 percent for ten percent battery variation. For information, contact RMS Electronics, Inc., 50 Antin Place, Bronx, New York 10462; (800) 223-8312 or (212) 892-6700.

## Test Equipment

### Vitek Offers Signal-Leakage Detector

**Vitek Electronics** is offering the model TR-1 tracer that detects RF leakage in CATV cable systems. It locates and measures leakage and determines whether radiation exceeds FCC limits, which can result in costly repairs or FCC violations.

The TR-1 does not require a separate transmitter since the receiver operates

with any cable TV video or pilot carrier, according to the company. The TR-1 is a self-contained calibrated receiver system and offers a crystal-controlled local oscillator with front panel frequency trim adjustment. Its 40 dB logged scale is accurate to  $\pm 1$  dB. The system includes tuned dipole antenna with magnetic base, headphones, near field probe, AC adapter/charger and gell cell batteries which provide up to 50 hours of operation on a single charge.

For information, contact Vitek Electronics, Inc., 4 Gladys Court, Edison, New Jersey 08817; (201) 287-3200.

### Tektronix Introduces Waveform Monitor

The 528A waveform monitor, marketed by **Tektronix, Inc.**, is designed for displaying and monitoring waveforms from camera outputs, video system output lines, and video input lines utilizing 525 line systems.

Users can obtain flexibility since the instrument has an option for 625 line systems. The unit is 5.25 inches high and one-half a rack space wide. Features of the 528A include an internal CRT graticule which provides the user with parallax-free waveforms for more accurate readings.

Selectable from the front panel, either of two 75-ohm video signal inputs may be



The Tektronix 528A waveform monitor.

displayed. The displayed video signal is also provided at a video output jack (on the rear panel) for viewing on a picture monitor or vectorscope.

A built-in one-volt calibration signal may be switched on to check vertical sensitivity calibration. A horizontal sweep selector switch provides 2H (two line), 1  $\mu$ s/div (expanded two line), 2V (two field) and 2V MAG (expanded two field) displays. Displays of RGB and YRGB waveforms from color processing amplifiers are provided by interconnection through a rear-panel nine-pin receptacle.

For information, contact Tektronix, Marketing Communications Department, P.O. Box 1700, Beaverton, Oregon 97075; (800) 547-1512 or (503) 644-9051.

### Texscan Introduces Installers' Meter

**Texscan** has introduced a low cost installers' meter specifically designed for the cable TV industry. The Installer 3 covers all frequencies from 50 MHz to 450 MHz without compensation control. Standard features are a two-piece moulded high impact enclosure, nickel cadmium rechargeable batteries, integral charger, audio recovery and calibration adjust for lab standardization. For information, contact Texscan Corporation, 2446 North Shadeland Avenue, Indianapolis, Indiana 46219; (317) 357-8781.

## Earth Stations

**TIW Systems, Inc.**, is marketing its Minitrac™ satellite tracking antenna control system designed for use on earth station antennas.

Designed to meet Comsat, Intelsat (A and B) and Telesat requirements, the Minitrac system is a modified version of the TIW Digitrac™ step-track system designed for use on antennas with larger diameter dishes. The Minitrac will reduce equipment required and cost in addition to maintaining the same basic step-tracking method and programming of the Digitrac system, according to the company.

The Minitrac system includes an incremental, step-track programmer that

# FILTERS for CATV/MDS/CARS/EARTH STA.

from



1 WEEK

VHF - UHF CATV  
Over 800 Solutions  
to CATV Problems:

- Channel removal
- Channel clean-up
- Adjacent channel
- RF offenders
- Co-channel

MDS: BPF



1 WEEK



CARS BPF  
in 72 Hours!

SATELLITE - 1 WEEK

- Full band (3.7 - 4.2 GHz)
- Single Transponder BPF
- IF - BPF 70 MHz  
820 MHz  
1200 MHz



(3.7 - 4.2 GHz)

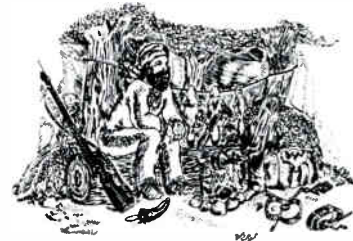

Ye  
Compleat  
TRAPPER

US - TOLL-FREE 1-800-448-1666  
NY/Hawaii/Alaska/Canada  
COLLECT 1-315-437-3953  
TWX - 710-541-0493

In Canada: INCOSPEC, Montreal-514-381-7674, RF COMM, Ontario-416-495-1030

In Switzerland CATEC 041-22619, Europe: Holland HF TRANSMISSE TECHNIK B.V., Telex 45046 Tel 08385-17231



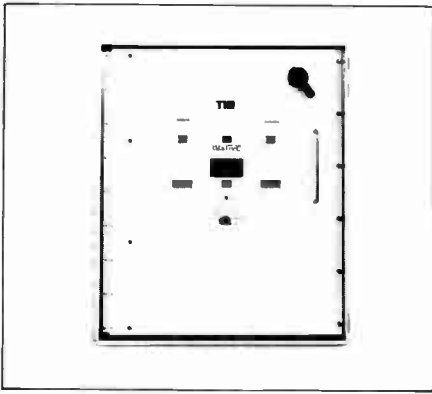

The Minitrac™ satellite tracking antenna control system from TIW Systems, Inc.

keeps the antenna pointed to the peak of the received RF energy while using only a beacon signal strength optimization loop. Self-contained in the antenna control and drive assembly limit is the control system comprised of a beacon signal, main power inputs and motor control and limit switch outputs. The box is designed for mounting in a control room or directly onto the pedestal.

Standard features also include the flexibility to accommodate a variety of input voltages, motor horsepower and connection schemes; modular construction which allows for easy troubleshooting or PC card replacement, and adjustable drive "ON" time for accommodating a

variety of gear ratios, motor RPMs and motor energization time.

For information, contact TIW Systems, Inc., 1284 Geneva Drive, Sunnyvale, California 94086; (408) 734-3900.

#### Scientific-Atlanta Markets New Receiver, Converter

Scientific-Atlanta, Inc., announced the introduction of a new video receiver and a new low-noise converter for satellite earth station subsystems. The new products are designed especially for satellite earth station applications in the cable TV, MATV and residential markets.

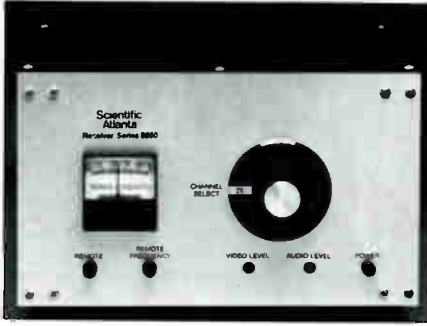

Scientific-Atlanta's model 6650 24-channel video receiver.

The new units, model 6650 video receiver and series 360 low-noise converter, are used in combination to enable satellite signals to be carried from the

earth station antenna to the video receiver over low cost, UHF-type coaxial cable. The series 360 low-noise converter is mounted at the antenna. It is a combination of a low-noise amplifier and a block downconverter. Satellite signals from the LNA are fed into the block downconverter, which then shifts the entire 500 MHz band down from frequencies in 3.7-4.2 GHz range to frequencies in 270-770 MHz range for input into the receiver.

The model 6650 24-channel video receiver uses threshold extension demodulation to enhance video and audio quality at low signal levels, even in the presence of multiple subcarriers. Impulse noise in the video signal is reduced near the threshold level, and picture quality is extended to considerably lower operating signal levels than with conventional demodulation.

For information, contact Patrick Buhana, Scientific-Atlanta, Box 105600, Atlanta, Georgia 30348; (404) 441-4000.

#### Harris Announces Nine-Meter Dish

The Harris Corporation has introduced a new satellite earth station antenna to its standard product line. Model 5251, nine-meter (29.5 feet) diameter reflector with a high efficiency cassegrain feed system and kingpost pedestal is designed for use by the



# ECONOMY 400 MHz

## Sadelco's new 733C SUPER economy SLM

designed for installers

- high accuracy
- automatic electronic shut-off
- new impact resistant case
- lowest price SLM in its class

call your Sadelco distributor for  
the special 733C SUPER price

**50TH**  
**Sadelco Anniversary**  
1960-1980  
**75 West Forest Avenue, Englewood, New Jersey 07631 201-569-3323**

General representative for Europe: Catec AG Luzern/Switzerland, Habsburgerstr 22. Tel. 041-23-90-56 Telex: TELFI 78168. In Canada: R.F. Communications

broadcast industry, private corporate networks, and TVRO systems in the fringe areas. This antenna fully complies with the FCC requirements for transmit/receive earth stations.

The kingpost pedestal is adjustable to view any domestic visible synchrosatellite. An optional motor drive system, model 7022, is available that will simultaneously drive azimuth, elevation, and polarization at the rate of one degree per second. The drive system control is capable of being preset to all angles of satellite positions. There is no limit to the number of positions selected. The high efficiency cassegrain feed options include dual polarized receive only, dual port transmit/receive, linear or circular polarization, linear co-polar (for operation with COMSTAR) and frequency reuse (four port) linear or circular polarized transmit/receive. Additional options include feed and subreflector deicing, and half or full main reflector deicing.

For information, contact Harris Antenna Operations, 2600 North Longview Street, Kilgore, Texas 75662; (214) 984-0555.

## Construction Equipment

### Burkeen Markets Vibratory Plow

**Burkeen Equipment Company** has announced its first "total capability vibratory plow" for direct burial of cable. The DP-30 features the capability of plowing, trenching and boring. Its compact size and 35-inch overall width allows easy passage through most yard gates.

The unit is powered by a 30 H.P., two-cylinder, air cooled diesel engine. The DP-30 features total hydrostatic power. Hydraulic components power the steering, four-wheel drive, raise and lower the plow and boom units, the boring unit, as well as the digging chain and vibratory gear box. The DP-30 plows 18 inches deep, with an assortment of blades available with chute as well as pull-in bullet-types. Trenching booms are available in 24-inch and 36-inch depths.

For information, contact Burkeen Equipment & Supply, 3238 Linda Place, Memphis, Tennessee 38118; (800) 238-5726.

### Stelco Introduces Telescopic Aerial Devices

**Stelco, Inc.**, is marketing its 500 series telescopic aerial devices for use on four truck and van models. The truck models have bottom-of-basket to ground heights of 24 and 26 feet, while the van models provide heights of 25 and 27 feet. When mounted on 10,000 GVW chassis and 9,500 GVW vans, the aerial devices do not require torsion bars. For information, contact Stelco, Inc., 5500 Kansas

Avenue, Kansas City, Kansas 66106; (913) 287-1500.

## Cable Tools

### Panduit Announces Bundling System

**Panduit Corporation** has developed the Panduit Pan-Steel™ bundling and identification system for use in severe environmental conditions.

The self-locking stainless steel ties in the system are installed with a tool that automatically tensions and cuts off the ties flush when a pre-determined tension is reached. The new Pan-Steel™ ties have resistance to abrasion, radiation, weathering, corrosion and temperature extremes. They have a 100 lb. minimum loop tensile strength and are available in four lengths for bundles up to eight-inch diameters. Ties for larger diameters are available by consulting the factory. Also included in the system are a stainless steel mount; stainless steel marker plate (for permanent identification of cables and bundles); metal acid etching pen; and indenter marker press. For information, contact Panduit Corporation, 17301 Ridgeland Avenue, Tinley Park, Illinois 60477; (312) 532-1800.

### PICO Introduces Strand Mount Device

**PICO** has introduced a new strand mount device. This addition to the PICO line enables cable operators to install traps and decoders on the line or under the eaves of the house. Simplified design of the PICO strand mount now allows second and third level pay TV installation when taps are already occupied with first level security devices. For information, contact PICO, 1001 Vine Street, Liverpool, New York 13088; (315) 451-0680.

## Miscellaneous

### PenCell Markets Cable Enclosure

Designed for underground cable television services, the AG-20 above-grade cable enclosure from **PenCell Plastics, Inc.**, is a one-piece, pedestal-like housing which is interchangeable with the grade-level cover of the company's PE-20 secondary splice box. The enclosure is molded of rigid, high-density polyethylene structural foam that resists environmental attack, deformation and impact.

The AG-20 enclosure has the additional advantage of airtight walls which prevent ground seepage or flooding from reaching splices or taps located in the above-ground box. This "bell jar" effect helps protect the integrity of electrical connections, even in wet locations, and assists in maintaining

stable impedance and isolation in cable television distribution systems.



The PenCell AG-20 above-grade cable enclosure.

Dimensions of the AG-20 are 14-inches wide by 22-inches long by 15-inches high, affording plenty of working space and room for attachment of auxiliary devices.

For information, contact PenCell Plastics, Inc., 1681 South Olden Avenue, Trenton, New Jersey 08690; (609) 888-2214.

### Extronix Introduces Signal Generator

A signal generator, designed expressly for aligning the sub-channel equalizers in two-way cable television systems, has been announced by **Extronix, Inc.**



The model SCAG-4 sub-channel alignment generator.

The model SCAG-4 generates picture carriers for Channels T7, T8, T9 and T10, separately switchable and adjustable. The output may be inserted into the system at any convenient tap and adjusted to any convenient level up to +45 dBmV in 75 ohms. The signals can then be used for adjusting the equalizers at each successive return amplifier along the cable.

The unit is small, lightweight and operates on D-size dry cells.

For information, contact Extronix, Inc., 64 Gough Avenue, Ivyland, Pennsylvania 18974; (215) 672-6644.

# CONGRATULATIONS IT'S A PICO

CONGRATULATIONS! WAY TO GO!  
and HOW SOON CAN WE GET THEM?

That's what our customers say when they discover that adding second and third level Pay TV is possible even if the taps are occupied with first level security devices.

We are proud to announce the PICO STRAND MOUNT as the latest addition to the PICO family of fine products.

Putting the strand mount on the line will place your security far enough away from the taps to make tampering virtually impossible. Traps and decoders come already installed or can be inserted in an empty Strand Mount housing.

Either way, it's a PICO, and in the cable industry, that's the name you can grow with.



1001 Vine Street, Liverpool NY 13088  
Telephone: (315) 451-0680

See us at booth #462

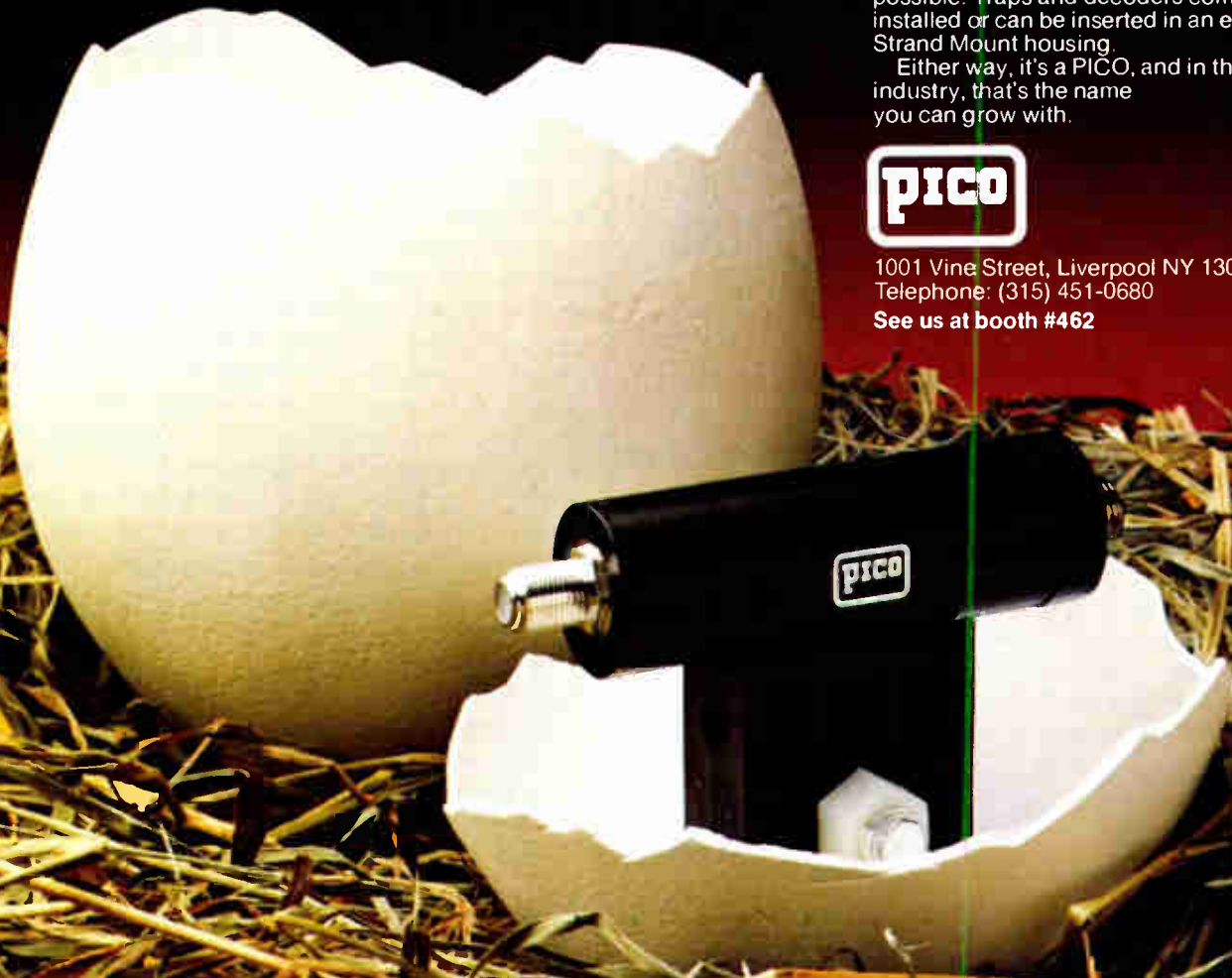

# STRAND MOUNT

Every day more than 300,000 CATV subscribers enjoy a better, more reliable picture with fiber optic links made by Times Fiber Communications.

So do system operators. With superior signals supplied by Times fiber optic links, they can extend higher quality video to more homes.

We're the leading supplier of fiber optic links—satellite downlinks, headend-to-studio and hub-to-hub trunks that carry signals with no measurable distortion. We've put in more CATV fiber optic systems than any other company.

## WHAT DO 300,000 SUBSCRIBERS GET FROM FIBER OPTIC CABLES?



*Times officials examine new 7-meter satellite antenna at the company's Wallingford, CT headquarters plant. The TVRO is used for experiments and to test fiber optic satellite downlinks.*

Why Times? Because we're totally committed to the CATV industry. We've been a leading U.S. manufacturer of coaxial cables for 30 years. We've pioneered almost every major technical trend in cables; and we were the first company to develop, manufacture and install reliable fiber optic cable links for this industry.

### ***Total System Responsibility***

Times provides total cable system responsibility because Times is a total manufacturer.

Our new fiber

*Officials check out new 9.5 km fiber optic satellite down-link at United Cable Television's headend in Plainville, CT.*



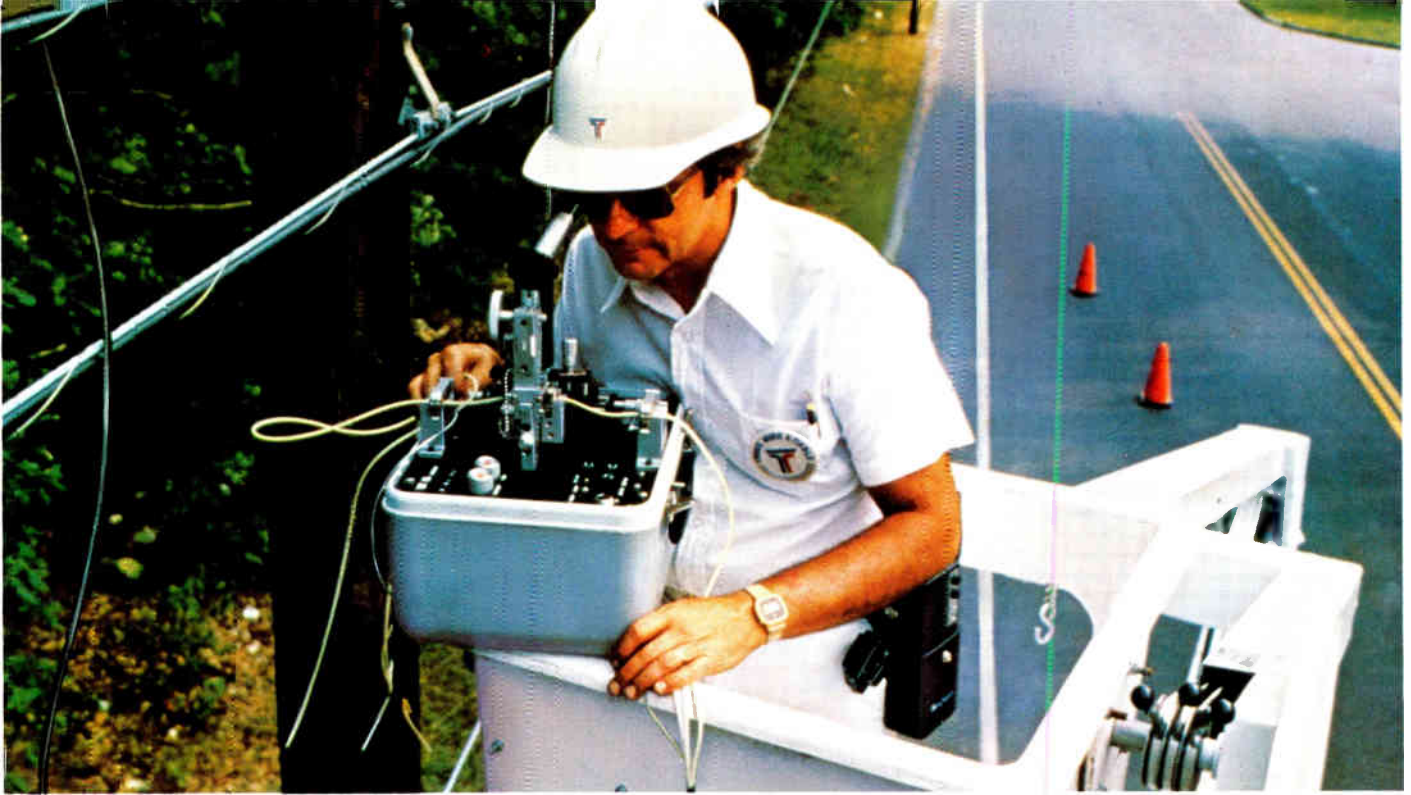

*A Times field engineer splices a fiber optic cable, during installation, with a portable fusion splicer. Times supervises every installation to assure technical integrity and practical performance.*

optic facility is one of the most modern in America. We make our own glass preforms, draw our own fiber, strand our own cable—aerial/duct, armored burial, and indoor.

You get everything from a single source. We engineer our own opto-electronic components—and supply all other items necessary for complete systems.

### ***Technical integrity and practical performance***

You'll find our Systems Engineering Department has the experience and technical back-up to select and test the best cable configuration and components for optimum, cost-efficient operation. And we supervise the installation of every system to assure technical integrity as well as practical performance.

That's why leading operators like Teleprompter, Falcon, Storer, United, and Vision (who recently ordered a second link) choose Times. They know they can count on Times to make it easy, make it right, make it reliable.

*So come to Times for practical fiber optics. Times Fiber Communications, Inc., 358 Hall Avenue, Wallingford, CT 06492. Call 203-265-8498.*

See us at the NCTA Show—Booth #154



TIMES FIBER COMMUNICATIONS, INC.  
**Times Wire & Cable Div.**

An **Insilco** Company

# RMS UNIPOWER™ SERIES

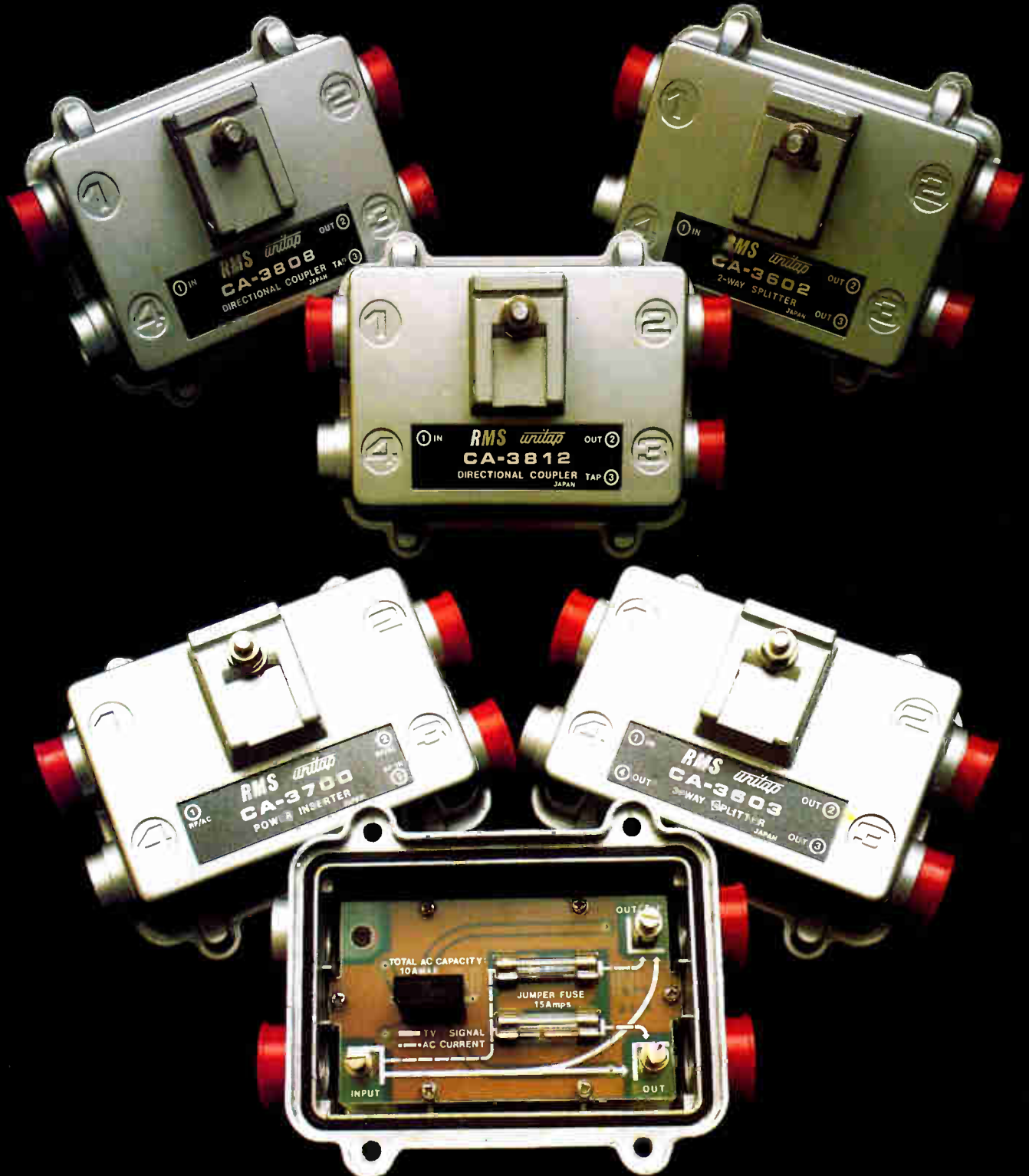

**It's Years Ahead. Available Immediately!**

**RMS** CATV DIVISION  
ELECTRONICS, INC.

RMS ELECTRONICS, INC.  
50 ANTIN PLACE  
BRONX, NY 10462  
CALL COLLECT (212) 892-1000  
TOLL FREE (800) 223-8312  
Canada Representative: Deskin Sales Corp.  
European Representative: Errivision AG

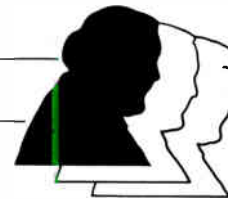

★ **Texscan Corporation** has promoted **Raleigh B. Stelle III** from national and international sales manager to vice president. Stelle will retain his sales duties as well as take on other responsibilities, according to the company. Stelle, a frequent contributor to **CED**, has served with Texscan for nine years.



*Raleigh B. Stelle III*

★ **Noel R. Bambrough** has become executive vice president of **Valley Cable TV** and is responsible for construction and operation of the West Valley system. Bambrough comes from Cable Atlanta, where his responsibility was the development of a 54-channel television system comparable to the one undertaken for the West San Fernando Valley.

In January 1981, Bambrough established an all time record by building the Atlanta system out at a rate of 150 miles per month. Bambrough has a long time association with cable television and is also vice president of operations of Cable America, Inc.

★ **Bud Marnell** and **Tom Kreager** have been appointed general manager for the **Douglas Communications Corporation** cable television systems in Louisiana and Tennessee, respectively.

Marnell, general manager of Douglas Communications Corporation of Louisiana, Inc., dba Jackson Cable TV, joined DCC in November 1980. Prior to that, Marnell was construction manager for McDonald Group Cablevision in Waterloo, Iowa, where he was responsible for the construction of 140 miles of cable plant. Earlier, Marnell was with Cable TV Construction, Ltd., in Newton, Kansas. He also served as system manager at Independence Cablevision in Independence, Kansas, and was with ATC in Jackson, Mississippi prior to that.

Kreager, general manager of Douglas Communications of West Tennessee, Inc., was most recently marketing manager at DCC of West Tennessee, Inc. Prior to that, Kreager was manager of sales and marketing for Toro Distribution of The Toro Company in Indianapolis.

★ **Scientific-Atlanta, Inc.**, has named **Delwin Bothof** vice president of marketing. Formerly a division marketing manager for Hewlett-Packard Company, Bothof joined the Atlanta-based communications and instrumentation company in February 1981.

In his new position, Bothof will be responsible at the corporate level for Scientific-Atlanta's worldwide marketing and sales activity.

Bothof holds a BS in electrical engineering from the University of Minnesota and a MS from Stanford University. He was with Honeywell, Inc., in technical roles prior to nine years employment with Hewlett Packard, where he served as a research and development project manager prior to his marketing assignments.



*Delwin Bothof*

★ **Andrew Juettner** has been appointed vice president of engineering for the Broadcast Products Division of **Harris Corporation**. Juettner has been responsible for management of Harris' engineering department since April, serving as director of engineering. He has been employed by Harris for 13 years and has worked at the Broadcast Products Division since 1975.

Among the positions Juettner held at Harris prior to his promotion were manager of AM RF and was director of studio product development. He is also involved the company's development of advanced satellite communications systems for national defense applications.

Juettner has a BS degree from New York Institute of Technology and has performed graduate work in electrical engineering and management at Florida Institute of Technology. He is a member of SMPTE and has made technical presentations at NAB, CCBA, and IEEE symposiums.

★ **Frank N. Noble** has been appointed supervisor of fiber optic cabling for **Times Fiber Communications, Inc.**, a subsidiary of Insilco Corporation. Noble will be responsible for the production of optical cable at TFC's new facility for the integrated production of optical fiber and cable in Wallingford, Connecticut.

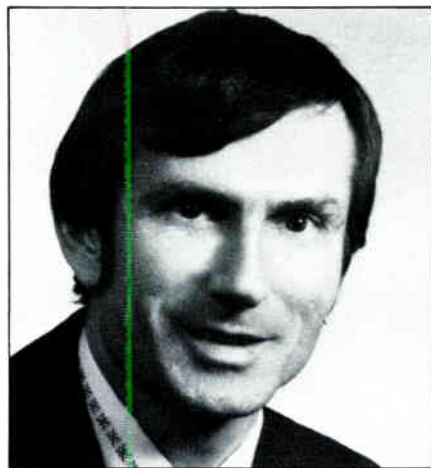

*Frank N. Noble*

★ **GANSAT**, Gannett's new satellite information network, has named **William Hider** as telecommunications director. Hider received his BS in electronics engineering from the Capitol Institute of Technology in Kensington, Maryland, and a MS in computer science from Johns Hopkins University. Hider joined Westinghouse Electric Corporation as an engineer in 1973, serving as a lead project engineer from 1976-79. In 1979 he served as president and chief operating officer for CIR-Q-TEL, Inc. Hider was appointed director for plans and proposals for the American Satellite Company in January 1980.

★ **Ed Gordon** has been named vice president of engineering and operations at **Times Mirror Cable Television**. Based at TMSPC's engineering office in Laguna Niguel, California, Gordon is responsible for the overall operation and construction of Times Mirror's new satellite uplink and playback facility. The facility, which is nearly complete, will have a staff of three engineers and 12 equip-

ment operators, as well as a video-tape librarian.

★ **PTS Electronics, Inc.**, has promoted **Jack Craig** to executive vice president. Craig was previously general manager and was based in the corporate headquarters in Bloomington, Indiana.

★ **Sonic Cable TV** has appointed **Les Johnson** as regional vice president of Santa Cruz County. Christopher Cohan, president of Sonic Cable TV, also announced that **Thomas Butch**, city administrator for Arroyo Grande for the past 17 years, has joined the company as regional vice president of San Luis Obispo County.

★ **Eagle Comtronics, Inc.**, has named **Thomas Woods** director of operations.

In his new position, Woods will work directly with Eagle's president, Alan Devendorf, in overseeing the company's manufacturing, engineering, quality control, data processing and purchasing operations. Currently, he is on special assignment in Eagle's manufacturing and engineering sections.

Prior to joining Eagle Comtronics, Woods was vice president of operations with Magnavox CATV. A native of Middletown, Ohio, Woods holds a BSEE from the University of Cincinnati, a MBA from Xavier University and is now earning a MSEE from the University of Cincinnati.



Thomas Woods

★ **Gill Management Services** has appointed **Donald Reiman** to the position of vice president, product planning. Reiman, in his new position, will be responsible for all aspects of product planning and the design of new software services for the cable television industry.

★ **Michael S. Stone**, former chief engineer with Valley Cablevision, has been named Northeast area technical manager for the Cable Communications Division of **Storer Broadcasting Company**. In his new position, Stone will supervise all technical functions of

Storer's cable operations in New England and New York State.

Joining Valley Cablevision of Seymour, Connecticut, in 1971, Stone supervised construction of that system as well as five other franchises operated by the company in New York State. Most recently, he has been employed by Atlantic-Pacific Cable Company in Southington, Connecticut, and has been working on construction of the cable system which will eventually serve Memphis, Tennessee. He began his career with Communications Management Corporation of Merrimack, New Hampshire, as a design engineer.

★ **Dennis M. Caprio** has recently been appointed manager of materials and production planning at **C-COR Electronics, Inc.** In this new position he will be responsible for the materials function of the company as well as production flow and control. Prior to joining C-COR, Caprio was employed for 14 years at Piper Aircraft Corporation.

★ **Robert D. Bilodeau** has been promoted to executive vice president and general manager of **Suburban Cablevision** of East Orange, New Jersey. Bilodeau helped found Suburban in 1973 and until his promotion served as vice president and general manager and vice president of engineering.

Bilodeau is a 26-year industry veteran, having served in most capacities of management and operations. He is also president of the New Jersey CATV Association, past president of the Society of Cable Television Engineers, an officer in the I.E.E.E. and a member of the Cable TV Pioneers. In 1978, he received the NCTA Award for outstanding contribution to engineering operations.

★ **Robert B. Lukingbeal** has been appointed senior vice president of operations for **N.A.P. Consumer Electronics Corporation**. The post includes responsibility for a realigned engineering organization.

N.A.P. Consumer Electronics Corporation, a subsidiary formed when North American Phillips Corporation acquired GTE Entertainment Products Group, manufactures and markets entertainment products under the Magnavox, Philco and Sylvania brands.

Two new vice presidents were also named to direct the realigned engineering organization. They are **John R. D'Aiuto** and **Eugene Lubchenko**. D'Aiuto, who was named vice president of color TV engineering, previously was director of engineering for GTE Entertainment Products Group. Lubchenko, who was appointed vice president of new products and systems, formerly was vice president of engineering for Magnavox Consumer Electronics Company.

D'Aiuto will be responsible for color TV design assurance project engineering for all color TV product lines, TV product feasibility, engineering services and mechanical engineering. As vice president of new products and systems, Lubchenko will be responsible for video, audio and special products; systems engineering, advanced development, competitive analysis, product safety coordination and engineering administration.

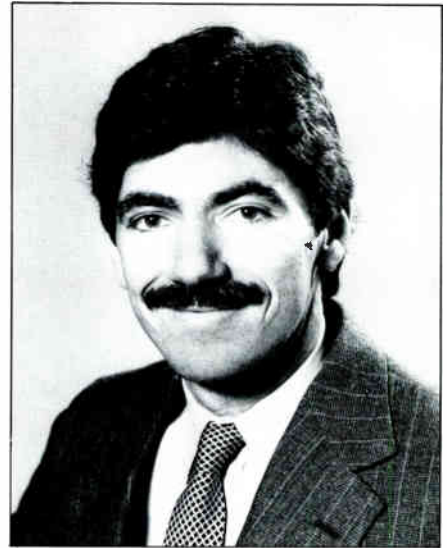

John B. Cooney

★ **John B. Cooney** has been named vice president and general manager of Commonwealth **Cablevision of Massachusetts, Inc.** He is responsible for all the company's operations in Agawam, Granby, Holyoke, South Hadley, West Springfield and Westfield, Massachusetts.

Cooney has spent the last three years with Teleprompter Corporation, first as manager of the Middletown, Connecticut, cable television system and then as general manager for the Worcester, Massachusetts, area system.

★ **Ray M. Clark** has been appointed chief engineer of **Cable TV Company of Puerto Rico** (Harris Cable Corporation). Clark's responsibilities will include supervision of all technical operations of the cable system, design of all new construction and the development of a new area of electronics which will bring additional satellite-delivered channels into Puerto Rico late this year.

Clark has 14 years of experience in cable TV, microwave transmission and satellite communications. His previous positions include field engineer with Theta Cable Company of Arizona and chief engineer with WGN Cable TV Systems in New Mexico and California. He holds a degree in electronics from Phoenix College in Phoenix, Arizona, and is a member of the New Mexico Board of Educational Advisors at T.V.I. in Albuquerque.



# Classifieds

## Employment Opportunities / HelpWanted

CMI Personnel Services

### YOUR TOTAL EMPLOYMENT SERVICES NETWORK

**EMPLOYERS . . .** Let us help you to find the right job applicant.

**JOB CANDIDATES . . .** Let us help you to find the best position available.

- **WE** are an employer-paid personnel agency.
- **WE** represent HUNDREDS of POSITIONS and CANDIDATES nationwide.
- **WE** have a proven track record (cable TV, pay TV, STV, MDS, satellite, radio and TV).
- **WE** are an established firm (1971) which provides various services including research, cable system brokerage, publications and special reports, and we own and operate two cable TV systems.
- **YOU** can improve your chances of success when you employ our large full-time professional staff . . . in strictest confidence, of course.
- **YOU** can receive at NO CHARGE, our bi-monthly "Top Jobs & Candidates" bulletin, read by thousands in the communications field, by just writing or giving us a call.
- **YOU** can benefit from our counsel on how to interview and from our knowledge of the job marketplace, i.e., salary, benefits and other compensation relative to job descriptions, geographical differences and competing services/ technologies.
- **TOGETHER** we should be able to accomplish your objective, so let's get started TODAY.



**COMMUNICATIONS MARKETING, INC.**  
PERSONNEL SERVICE

(714) 461-7891  
2326 Tampa Ave., El Cajon, CA 92020

### CABLE CAREER HOTLINE

1-800-433-2160

- **DIRECTOR OF ENGINEERING** . . . . . Salary open  
New England area.
- **CORPORATE ENGINEER** . . . . . to \$35,000  
New position upper Midwest location.
- **SYSTEM MANAGER** . . . . . to \$20-25,000  
New system, Southern location.
- **REGIONAL ENGINEER** . . . . . to \$25,000  
Small MSO, Midwest, light travel.
- **CHIEF TECHNICIAN** . . . . . \$16,000 plus  
Good benefits, lots of growth, Southwest location.
- **CHIEF TECHNICIAN** . . . . . \$18,000 plus  
Grow with sound company, Northeast location.
- **MANAGER TECHNICIAN** . . . . . \$18-20,000  
Great opportunity, Southern system.
- **CHIEF TECHNICIAN/PLANT MANAGER** . . . . . mid-\$20s  
Strong supervisory skills a must, Southwest location.
- **CHIEF AND BENCH TECHNICIAN** . . . . . Salary negotiable.  
Major MSO position, Gulf Coast location.
- **LEAD TECHNICIAN** . . . . . mid teens  
Major step up to Chief Technician, Gulf Coast region.
- **TRUNK TECHNICIAN** . . . . . \$7.00 per hour  
Outstanding opportunity, Florida location.
- **SERVICE TECHNICIAN** . . . . . \$5.00 per hour  
Great start for good technician, Florida location.
- **SERVICE TECHNICIAN** . . . . . \$6.00 per hour  
Gulf Coast area.

All positions include benefits and moving expenses. Call day, evenings or weekends for information about these and other opportunities.

In Texas, call collect: (817) 236-7187

**JIM YOUNG & ASSOCIATES**  
P.O. Box 79089 • Ft. Worth, TX 76179

CATV RECRUITERS

FEES PAID

### CHIEF ENGINEER

CATV system in Southwest New Mexico has an opening for a Chief Engineer, minimum of 5 years experience, with management skills. Must be knowledgeable in microwave, earth stations, headend repair, system layout and design. System has presently 250 miles of plant with 13,000 subscribers. Send resume and salary requirements to:

**Robert Macloch**  
Director of Operations  
Las Cruces TV Cable  
P.O. Box J  
Las Cruces, NM 88-004  
Phone (505) 523-2531  
Equal opportunity employer

### ENGINEERING • TECHNICIANS OPERATIONS • FRANCHISING SYSTEM MANAGEMENT POSITIONS AVAILABLE



**CAREER  
MARKETING  
ASSOCIATES**

Jan Sather  
Cable Television Specialist  
5031 South Ulster Suite 430  
Denver, Colorado 80237  
(303) 779-8890

## J-RAND PERSONNEL, INC.

1-F Waterford Professional Center — York, PA 17402  
(717) 757-9697

- Materials Mgr.—MBA or equivalent, 5 yrs. preferred in electronics.
- Sr. RF Engr.—BSEE, FCC License, Design & Development.
- Field Engr. (Turnkey)—CATV Systems, extensive travel.
- Reliability Engineer—BSEE or ME, 5 yrs. commercial electronics.
- Test Engr.—BSEE, Digital electronics, microprocessors.
- RF Amplifier Design Engr.—BSEE, CATV equipment.
- Packaging Engineer—BSME, electronic packaging.
- Application Support Engr.—BSEE, customer assistance, 50% travel.
- RF/Digital Design Engr.—RF/Digital interface.
- Digital Design Engr.—BSEE, Microprocessor-based system.

- National Listings •
- Salaries Open Depending Upon Experience and Education •
- All Fees Paid by Employers •

## SYSTEM TECHNICIANS

Cablecom-General, Inc., one of the leaders in the growing cable television industry is seeking experienced CATV Technicians.

We offer excellent benefits and opportunity for growth. Send resume to Personnel manager,

**Cablecom-General, Inc.**  
1880 E. Arapahoe Road  
Englewood, CO 80112  
We are an equal opportunity employer.

## SENIOR PROJECT ENGINEER NEW PRODUCTS

One of the largest and fastest growing manufacturers of communications systems and components seeks a Senior Project Engineer for New Advanced Development Group. Specific responsibilities will include the hands-on development of satellite systems products, and scrambling, decoding and encoding devices for use in direct-to-home services. A BSEE is required with experience in radio frequency engineering, and some familiarity with digital is preferred. Ideal background includes knowledge of test equipment for development and refinement of receiving equipment. Attractive East Coast location. Please send resume with salary history to: Box CED-0580-1.

**KINSMAN DESIGN ASSOCIATES, INC.**



### CATV SYSTEM DESIGN

- VERSATILE COMPUTER PROGRAMS UTILIZING WANG PCS II
- EXPERIENCED PERSONNEL
- WILL ACCOMMODATE ALL DESIGN FREQUENCY REQUIREMENTS

1562 S. PARKER RD. SUITE 314  
DENVER, COLORADO 80231  
(303) 896-0380

## CATV EQUIPMENT REPAIRS

- Line & Distr. Amplifiers
- Field Strength Meters
- Headend & CCTV Gear
- Fast Turnaround
- Quality Workmanship
- Reasonable Rates

All repairs are unconditionally guaranteed  
For more information call collect

**VideoTech Service Inc.**

CATV · MATV · CCTV

4505-D W. ROSECRANS AVENUE  
HAWTHORNE CALIFORNIA 90250  
213-675-3266

## BENCH TECHNICIAN

If you have 3 to 5 years experience in troubleshooting and repairing cable TV headend equipment, FSM's and amplifiers send resume and salary requirements to: RMT Engineering, 625 East Taylor Avenue, Sunnyvale, CA 94086, Attn: Richard McLean, phone (408) 733-4830.

## TELE—ENGINEERING CORP. Engineers and Contractor FOR QUALITY CABLE COMMUNICATIONS SYSTEMS

- Strandmaps
- System Design
- Construction Supervision
- Head End Surveys and Design
- MW Surveys and Design
- TURNKEY IMPLEMENTATION

As independent turnkey contractor, we will take your project from conceptual stages to completion. Through selection of quality system components, we will deliver a plant of the highest reliability, performing to the most stringent system performance specifications.

2 Central Street  
Framingham, Massachusetts 01701  
(617) 877-6494

## ENGINEERING AND TECHNICAL SALES POSITIONS

We specialize in the placement of Technical Engineers with Television Stations, Cable TV, Satellite Programmers & Networks, Pay TV, Manufacturers, Industrial TV, CCTV, Production Houses & Dealers. Also, technical sales with Manufacturers & Dealers. All levels, positions & locations nationwide. Employers pay all fees - confidential, professional. Over \$3,000,000.00 in Salaried Positions Placed. Employee & Employer inquiries invited.

PHONE/RESUME - Alan Kornish (717)287-9635

## KEY SYSTEMS

106 new bridge center, kingston, pa. 18704

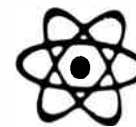

## RMT ENGINEERING

### CATV/MATV REPAIRS

60-DAY WARRANTY  
10-15 DAYS TURNAROUND

FOR PRICES WRITE TO

625 E. TAYLOR AVENUE  
SUNNYVALE, CALIFORNIA 94086  
(408) 733-4830

## CATV PARTS IN STOCK!

TYPE	Hybrid Chips	BRAND
MHW1342	7 Pin-34db	Motorola
MHW1343	9 Pin-34db	Motorola
MHW1171	7 Pin-17db	Motorola
MHW1172	7 Pin-17db	Motorola

TYPE	Quads	PHI
PHQ6202		

TYPE	Transistors	TRW
PT4612	Stud Mount	
SS4312	To-39	Motorola

Also Matched Pairs

We love the competition—you enjoy the savings!

Call for prices on Sadelco meters, surge protection devices, splitters, matching transformers, attenuator, traps & notch filters.

We stock and cross reference many parts of the leading CATV manufacturers.

**Nemtron**

Electronics Ltd.

SPECIALIST IN ALL TYPES OF ELECTRONIC COMPONENTS

15 Main Street  
East Rockaway, NY 11518

TOLL FREE: 800/645-2300  
NEW YORK: 516/599-6400

## Professional Services

### All You Should Know About SLM's...



...Is covered completely in the new NCTI 28-minute Video Cassette, **Signal Level Meters: Use, Care and Maintenance.** Train on the job about the purpose, design, use and care of SLM's. Write today for full information on this effective new educational tool.

**NATIONAL CABLE TELEVISION INSTITUTE** P.O. Box 27277  
Denver, CO 80227  
(303) 697-4967



**Jerry Conn Associates, Inc.**  
MANUFACTURERS' AGENT

## WE WORK FOR YOU!

P.O. BOX 444  
CHAMBERSBURG, PA. 17201  
CALL TOLL FREE: 800-233-7117  
IN PA. CALL COLLECT (717) 263-8258

## For Sale

### EQUIPMENT FOR SALE

Texscan 9550 Simo Sweep Transmitter and receiver. Includes charger and manuals. Calibrated 11/7/80. Also several Commander I processors and Tel-Trol modulators in good condition. Call Don Rocker (315) 337-1120.



**ROME NEWCHANNELS**  
CABLE TELEVISION  
1117 ERIE BOULEVARD, W. • ROME, NEW YORK 13446

### SIGNAL GENERATOR

Four-channel signal generator for aligning two-way return equalizers. Outdoor, dry or nicad battery. Models SCAG-4-D, -N. Write or Phone for details.

Extronix, Inc.  
64 Gough Avenue  
Ivyland, PA 18974  
(215) 672-6644

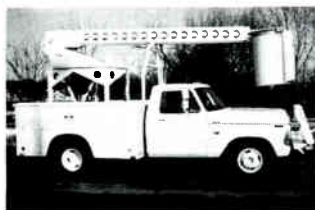

### USED AERIAL BUCKET TRUCKS

Most units completely rebuilt. Specializing in CATV use.

Telsta SU34s and T40s  
Plus other makes and models.  
(In the Boston area.)

(Call toll-free)  
1-800-343-4614

Leo LeBlanc  
(617) 893-3900  
Colvins Inc. Auto Center  
185 Prospect Street  
Waltham, Mass. 02154

For Information on  
Classified Advertising  
Contact Suzanne Sparrow  
(303) 573-1433

# HYBRIDS UNLIMITED

Stocked for Immediate Shipment

ALL TRW®  
CA TYPES

ALL MOTOROLA  
MHW & SHW  
TYPES

"QUADS"

Complete  
Line of  
Replacement  
Components

Call or write today  
for the most complete  
replacement components  
catalog in the industry.

Toll-Free:  
800-327-6690

**BROADBAND  
ENGINEERING, INC.**

1525 Cypress Rd., Jupiter, Florida 33458  
(305) 747-5000

## MHz Mega Hertz Sales

Manufacturers Represented:

- Blonder Tongue
- Broadband Engineering
- CCS Hatfield
- Computer Video
- Control Technology
- EEG Enterprises
- Intercept Corp.
- Insulation Systems
- Lindsay Products
- LRC Electronics
- Multiplier Industries
- Onan
- Vitek

3501 S. Corona, P.O. Box 2001  
Englewood, CO 80110  
(303) 761-3304  
(800) 525-8386

3815 NW 82nd St.  
Kansas City, MO 64151  
(816) 436-2512

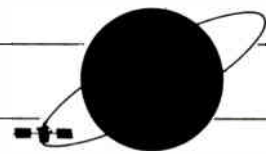

Signal	Day	Start/Stop	Alert Tones	Satellite/Transponders	Signal	Day	Start/Stop	Alert Tones	Satellite/Transponders	
<b>CBN</b>		24 hrs.	None	F1.#8	<b>Showtime</b>			Program	F1.#12 (E,C)	
<b>CNN</b>		24 hrs.	None	F1.#14		May 1	3:30 p.m. / 7:30 a.m.	576* / #	F1.#10 (M,P)	
<b>Cabletext</b>		24 hrs.	None	F1.#6 Vertical Blanking		May 2	7:30 a.m. / 7:00 a.m.	Scramble		
<b>C-SPAN</b>	Weekdays	12:00 p.m. / 6:30 p.m.	195* / #	F1.#9		May 3	7:00 a.m. / 2:30 a.m.	679* / #		
<b>ESPN</b>		24 hrs.	None	F1.#7		May 4	3:30 p.m. / 3:03 a.m.	Off-line		
<b>Front Row</b>		2:30 p.m. / 2:30 a.m.	481* / #	F1.#12 (E,C) F1.#10 (P,M)		May 5	3:00 p.m. / 3:27 a.m.	753* / #		
<b>HBO</b>			Program	F1.#24		May 6	3:30 p.m. / 3:13 a.m.	Access		
	May 1	5:00 p.m. / 4:07 a.m.	729* / #	F1.#22		May 7	3:30 p.m. / 2:27 a.m.	843* / #		
	May 2	2:30 p.m. / 3:32 a.m.	Scramble	F1.#23		May 8	3:30 p.m. / 7:30 a.m.		May 21	3:30 p.m. / 3:00 a.m.
	May 3	3:00 p.m. / 1:50 a.m.	835* / #	F1.#20		May 9	7:30 a.m. / 7:30 a.m.		May 22	3:00 a.m. / 8:00 a.m.
	May 4	5:00 p.m. / 2:40 a.m.	Duplication		May 10	7:30 a.m. / 2:15 a.m.		May 23	8:00 a.m. / 8:00 a.m.	
	May 5	5:00 p.m. / 2:23 a.m.	940* / #		May 11	3:30 p.m. / 2:56 a.m.		May 24	8:00 a.m. / 3:42 a.m.	
	May 6	5:00 p.m. / 2:42 a.m.	Take-2 E.		May 12	3:30 p.m. / 2:05 a.m.		May 25	3:30 p.m. / 2:26 a.m.	
	May 7	5:00 p.m. / 2:28 a.m.	592* / #		May 13	3:30 p.m. / 3:06 a.m.		May 26	3:30 p.m. / 2:26 a.m.	
	May 8	5:30 p.m. / 3:15 a.m.	Take 2 W.		May 14	3:30 p.m. / 3:26 a.m.		May 27	3:30 p.m. / 3:26 a.m.	
	May 9	2:30 p.m. / 4:24 a.m.	681* / #		May 15	3:30 p.m. / 8:00 a.m.		May 28	3:30 p.m. / 4:06 a.m.	
	May 10	3:00 p.m. / 1:50 a.m.			May 16	8:00 a.m. / 7:30 a.m.		May 29	3:00 p.m. / 8:00 a.m.	
	May 11	5:00 p.m. / 2:16 a.m.			May 17	7:30 a.m. / 2:45 a.m.		May 30	8:00 a.m. / 5:30 a.m.	
	May 12	5:30 p.m. / 3:04 a.m.			May 18	3:00 p.m. / 2:06 a.m.		May 31	5:30 a.m. / 3:57 a.m.	
	May 13	5:30 p.m. / 1:58 a.m.			<b>SPN</b>		24 hrs.	None	Westar II, #9	
	May 14	5:00 p.m. / 2:13 a.m.			<b>SIN</b>		24 hrs.	None	Westar III, #8	
	May 15	5:00 p.m. / 3:51 a.m.			<b>Trinity (KTBN)</b>		24 hrs.	None	F1.#13	
	May 16	2:30 p.m. / 3:49 a.m.			<b>USA Network</b> Off-times are listed below. For on-times, see notes below.				F1.#9	
	May 17	3:30 p.m. / 2:28 a.m.				May 1	2:00 a.m.		May 17	4:00 a.m.
	May 18	5:00 p.m. / 2:13 a.m.				May 2	2:00 a.m.		May 18	2:00 a.m.
	May 19	5:30 p.m. / 2:35 a.m.				May 3	2:30 a.m.		May 19	3:30 a.m.
	May 20	5:00 p.m. / 2:10 a.m.				May 4	2:30 a.m.		May 20	1:00 a.m.
	May 21	5:30 p.m. / 2:12 a.m.				May 5	3:30 a.m.		May 21	1:00 a.m.
	May 22	5:00 p.m. / 4:44 a.m.				May 6	2:00 a.m.		May 22	2:00 a.m.
	May 23	3:00 p.m. / 3:50 a.m.				May 7	2:00 a.m.		May 23	2:30 a.m.
	May 24	3:00 p.m. / 4:06 a.m.				May 8	2:00 a.m.		May 24	2:00 a.m.
	May 25	2:30 p.m. / 2:40 a.m.				May 9	2:00 a.m.		May 25	2:30 a.m.
	May 26	5:30 p.m. / 2:15 a.m.				May 10	4:00 a.m.		May 26	3:00 a.m.
	May 27	6:00 p.m. / 2:50 a.m.				May 11	2:30 a.m.		May 27	2:00 a.m.
	May 28	5:00 p.m. / 2:15 a.m.				May 12	3:30 a.m.		May 28	2:00 a.m.
	May 29	5:30 p.m. / 3:34 a.m.				May 13	2:00 a.m.		May 29	2:00 a.m.
	May 30	2:30 p.m. / 4:44 a.m.				May 14	3:30 a.m.		May 30	3:00 a.m.
May 31	2:00 p.m. / 2:32 a.m.			May 15		4:00 a.m.		May 31	3:30 a.m.	
<b>HTN</b>		8:00 p.m. / 10(11:00) p.m.	517* / #	F1.#21	May 16	2:00 a.m.				
<b>KFIX</b>		2-4 hrs./day	None	F1.#1	USA Network. On-time is 6:30 p.m. weekdays, except May 21: 6:00 p.m. Saturdays: 10:00 a.m. Sundays: May 3, 10: 5:00 p.m.; May 17, 31: 7:00 p.m.; May 24: 4:00 p.m.					
<b>KTVU</b>	Weekdays	7:00 a.m. / 1:00 a.m.	None	F1.#1	Calliope. Weekdays: 6:30 p.m. to 7:30 p.m., except May 21: 6:00 p.m. to 7:00 p.m. Saturdays 10:00 a.m. to 1:00 p.m.					
	Weekends	7:00 a.m. / 4:00 a.m.			The English Channel. Saturdays: 1:00 p.m. to 5:00 p.m. Tuesdays: 11:00 p.m. to 1:00 a.m., except May 26: 10:30 p.m. to 12:30 a.m. Sundays: 11:00 p.m. to 1:00 a.m., except May 24, 31: 10:30 p.m. to 12:30 a.m.					
<b>Modern Talking Pictures</b>			243* / #	F1.#22	<b>WGN</b>	Mon.-Thurs.	5:42 a.m. / 3(3:30) a.m.	None	F1.#3	
	Weekdays	12:00 p.m. / 5:00 p.m.				Weekends	Ends 3:00 a.m. on Sun.			
	Weekends	7:00 a.m. / 12:00 p.m.			<b>WOR</b>		24 hrs.	None	F1.#17	
<b>The Movie Channel</b>		24 hrs.	None	F1.#5 (E,C) F1.#11 (M,P)	<b>WTBS</b>		24 hrs.	None	F1.#6	
<b>Newstime</b>		24 hrs.	276* / #	F1.#6	<b>Women's Channel</b>		24 hrs	None	F1.#6 Subcarrier	
<b>PTL</b>		24 hrs.	None	F1.#2						
<b>Reuters</b>	Weekdays	4:00 a.m. / 7:00 p.m.	None	F1.#18						

E = eastern M = mountain  
C = central P = pacific

All program times are listed for the eastern time zone, unless otherwise noted.

What you see is what  
you're looking for.

What you don't  
see makes the  
difference.

Traps by Eagle!



### Trap For Tiered Service! Perfect For One Or Multichannels.

What you see is the Eagle Comtronics name, sign of Eagle Quality, stamped on our notch filter trap. **THE EAGLE TRAP IS THE SUREST, MOST ECONOMICAL WAY TO SECURE YOUR SYSTEM'S PREMIUM CHANNELS** — that's what you're looking for.

What you don't see is inside the trap. And that makes the difference. Our trap is completely potted to prevent absorption and to stabilize the circuitry. The Eagle trap is also stable over a wide temperature range, (-40° to +140°F), and can withstand a half ton of pull. There's more, too:

- \* Choice of channels 2-10, including midband
- \* No subscriber access to security system
- \* Designed for tiered service
- \* Nickel plated brass housing resists corrosion
- \* Pay channel video carrier rejection averages better than -60dB with 200 kHz notch width
- \* Band elimination filter- either 3 channel or 9 channels (GHI or A through I)
- \* Upper adjacent video carrier incursion of less than 2dB
- \* Indoor and outdoor security shields available
- \* Machined and interlocked housing is stronger than standard traps with welded or soldered cases



Actual Size



7841 West River Road  
Baldwinsville, New York 13027  
(315) 638-2586

In Canada: Desklin Sales Montreal • Toronto • Vancouver  
(416) 493-1412

CALL TOLL FREE  
**800-448-3311**

# CA-2500

## A MOVE TO QUALITY



**RMS** CATV DIVISION  
ELECTRONICS, INC.

RMS ELECTRONICS, INC.  
50 ANTIN PLACE  
BRONX, NY 10462  
CALL COLLECT (212) 892-1000  
Toll Free (800) 223-8312

\*Canadian Representative: Desklin Sales Corp  
\*European Representative: Erivision AG

© RMS Electronics, Incorporated 1978