

BYTE

THE SMALL SYSTEMS JOURNAL®

SEPTEMBER 1987 VOL.12, NO.10

\$3.50 IN UNITED STATES
\$4.50 IN CANADA / £1.75 IN U.K.
A MCGRAW-HILL PUBLICATION
0360-5280

THEME

Printer Technologies

Ciarcia's
ZyMOS AT-on-a-board

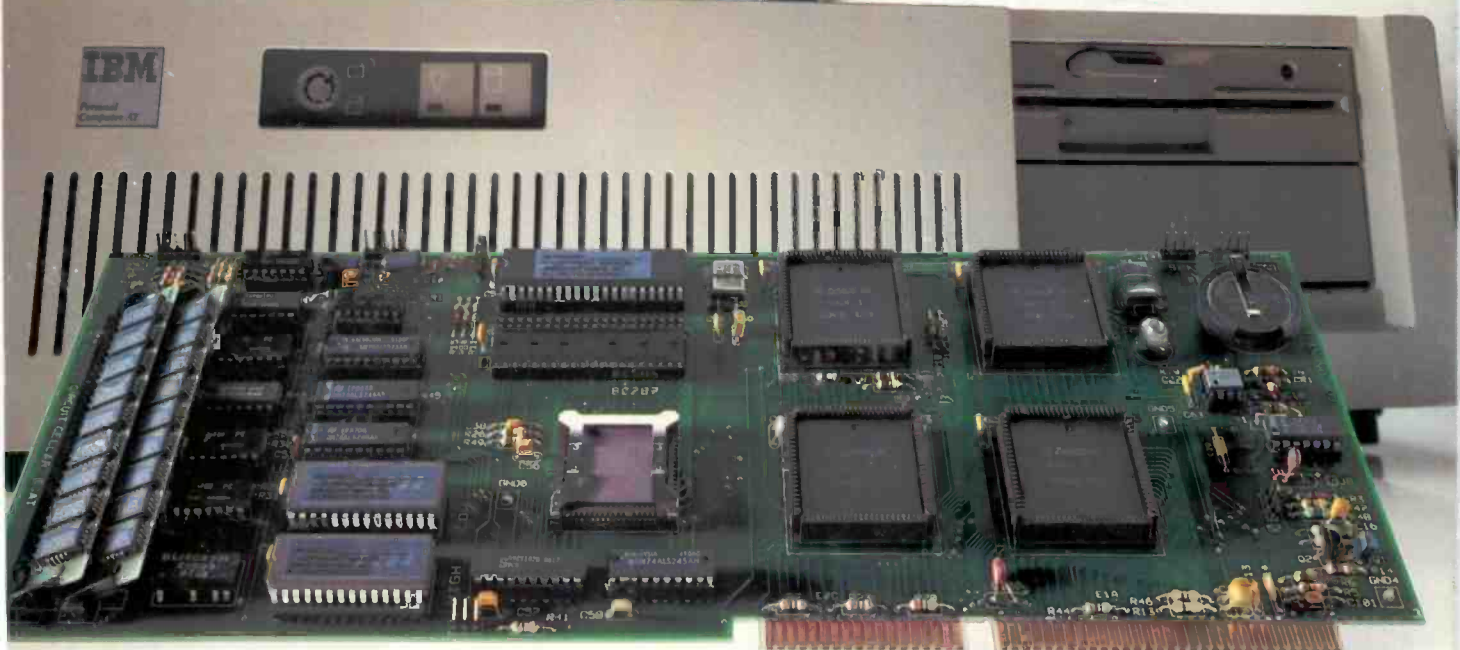

Turbo C: **NEW!** Powerful optimizing compiler ever

Sieve benchmark

	Turbo C	Microsoft® C
Compile time	2.4	13.51
Compile and link time	4.1	18.13
Execution time	3.95	5.93
Object code size	239	249
Execution size	5748	7136
Price	\$99.95	\$450.00

Benchmark run on an IBM PS/2 Model 60 using Turbo C version 1.0 and the Turbo Linker version 1.0; Microsoft C version 4.0 and the MS overlay linker version 3.51.

Technical Specifications

- ☑ **Compiler:** One-pass optimizing compiler generating linkable object modules. Included is Borland's high-performance Turbo Linker.™ The object module is compatible with the PC-DOS linker. Supports tiny, small, compact, medium, large, and huge memory model libraries. Can mix models with near and far pointers. Includes floating point emulator (utilizes 8087/80287 if installed).
- ☑ **Interactive Editor:** The system includes a powerful, interactive full-screen text editor. If the compiler detects an error, the editor automatically positions the cursor appropriately in the source code.
- ☑ **Development Environment:** A powerful "Make" is included so that managing Turbo C program development is highly efficient. Also includes pull-down menus and windows.
- ☑ **Links with relocatable object modules** created using Borland's Turbo Prolog into a single program.
- ☑ **Inline assembly code.**
- ☑ **Loop optimizations.**
- ☑ **Register variables.**
- ☑ **ANSI C compatible.**
- ☑ **Start-up routine source code included.**
- ☑ **Both command line and integrated environment versions included.**
- ☑ **License to the source code for Runtime Library available.**

Join more than 100,000 Turbo C enthusiasts. Get your copy of Turbo C today!

Minimum system requirements: All products run on IBM PC, XT, AT, PS/2, portable and true compatibles. PC-DOS (MS-DOS) 2.0 or later. 384K RAM minimum. Basic Telecom and Editor Toolboxes require 640K.

Borland International
4585 Scotts Valley Drive, Scotts Valley, CA 95066
Telephone: (408) 438-8400 Telex: 172373

Why more than 600,000 programmers worldwide are using Turbo Pascal today

The irresistible force behind Turbo Pascal's worldwide success is Borland's advanced technology. We created a compiler so fast, that Turbo Pascal® is now the worldwide standard. And there are more tools for Turbo Pascal than for any other development environment in the world.

You'll get everything you need from Turbo Pascal and its 5 Toolboxes

Turbo Pascal and Family are all you'll ever need to perfect programming in Pascal.

If you've never programmed in Pascal, you'll probably want to start with Turbo Pascal Tutor® 2.0, and as your expertise quickly grows, add Toolboxes like our

- Database Toolbox®
- Editor Toolbox®
- Graphix Toolbox®
- GameWorks®
- and our newest,
- Numerical Methods Toolbox™



And because Turbo Pascal is the established worldwide standard, 3rd party, independent non-Borland developers also offer an incredible array of programs for Turbo Pascal. **Only \$99.95!**

“ Borland International's Turbo Pascal took the programming world by storm. A great compiler combined with a good editor at an astounding price, the package quickly came to be called, simply, Turbo—and has sold more than 500,000 copies.

Stephen Randy Davis, PC Magazine

Language deal of the century. ”

PC Magazine

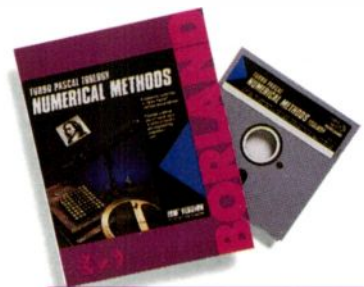

For Scientists and Engineers: Turbo Pascal Numerical Methods Toolbox

The Numerical Methods Toolbox is a complete collection of Turbo Pascal routines and programs. Add it to your development system and you have the most comprehensive and powerful numerical analysis capabilities—at your fingertips!

The Numerical Methods Toolbox is a state-of-the-art mathematical toolbox with these ten powerful features:

- ☑ Zeros of a function
- ☑ Interpolation
- ☑ Differentiation
- ☑ Integration
- ☑ Matrix Inversion
- ☑ Matrix Eigenvalues
- ☑ Differential Equations
- ☑ Least Squares
- ☑ Fourier Transforms
- ☑ Graphics

Each module comes with procedures that can be easily adapted to your own program. The Toolbox also comes complete with source code. So you have total control of your application.

Only \$99.95!

Turbo Prolog: The Natural Language of Artificial Intelligence

Whether you're a first-time programmer or an experienced one, Turbo Prolog's natural implementation of Artificial Intelligence soon shows you how to build expert systems, natural language interfaces, customized knowledge bases and smart information management systems.



Turbo Prolog and Turbo C work hand-in-hand

Turbo Prolog® interfaces perfectly with Turbo C® because they're both designed to work with each other.

The Turbo Prolog/Turbo C combination means that you can now build powerful commercial applications using two of the most powerful languages available.

Turbo Prolog's development system includes:

- ✓ A complete Prolog compiler that is a variation of the Clocksin and Mellish Edinburgh standard Prolog.
- ✓ A full-screen interactive editor.
- ✓ Support for both graphic and text windows.
- ✓ All the tools that let you build your own expert systems and AI applications with unprecedented ease.

All Borland products are trademarks or registered trademarks of Borland International, Inc., or Borland/Analytica, Inc. Other brand and product names are trademarks or registered trademarks of their respective holders.
Copyright 1987 Borland International

BI-1131

“ An affordable, fast, and easy-to-use language that will delight the newcomer . . . You experienced Prolog hackers will likewise be delighted, if not astonished, by the features and performance of the Turbo Prolog development environment.

Turbo Prolog offers generally the fastest and most approachable implementation of that language.

Darryl Rubin, *AI Expert* ”

How Turbo Prolog's new Toolbox adds 80 powerful tools and 8000 lines of source code

In keeping with Borland tradition, we've quickly added the new Turbo Prolog Toolbox™ to Turbo Prolog.

With 80 tools and 8000 lines of source code that can easily be incorporated into your own programs—and 40 sample programs that show you how to put these AI tools to work—the Turbo Prolog Toolbox is a highly intelligent, high-performance addition. **Only \$99.95!**

Turbo Prolog Toolbox features include:

- ✓ Business graphics generation: boxes, circles, ellipses, bar charts, pie charts, scaled graphics
- ✓ Complete communications package: supports XMODEM protocol
- ✓ File transfers from Reflex,® dBASE III,® 1-2-3,® Symphony®
- ✓ A unique parser generator: construct your own compiler or query language
- ✓ Sophisticated user-interface design tools
- ✓ Contains 40 example programs
- ✓ Easy-to-use screen editor: design your screen layout and I/O
- ✓ Calculated fields definition
- ✓ Over 8,000 lines of source code you can incorporate into your own programs

Turbo C The most powerful compiler

Our new Turbo C generates fast, tight, production-quality code at compilation speeds of more than 13,000 lines a minute!

It's the full-featured optimizing compiler everyone has been waiting for.

Switching to Turbo C, or starting with Turbo C, you win both ways

If you're already programming in C, switching to Turbo C will make you feel like you're riding a rocket instead of pedaling a bike.

If you're never programmed in C, starting with Turbo C gives you an instant edge. It's easy to learn, easy to use, and the most efficient C compiler at any price.

Only \$99.95!

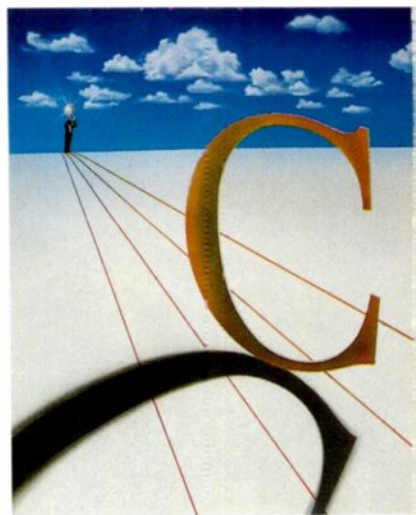

“ Turbo C does look like What We've All Been Waiting For: a full-featured compiler that produces excellent code in an unbelievable hurry . . . moves into a class all its own among full-featured C compilers . . . Turbo C is indeed for the serious developer . . . One heck of a buy—at any price.

Michael Abrash,
Programmer's Journal ”

Turbo C, Turbo Basic, Turbo Pascal and Turbo Prolog: technical excellence

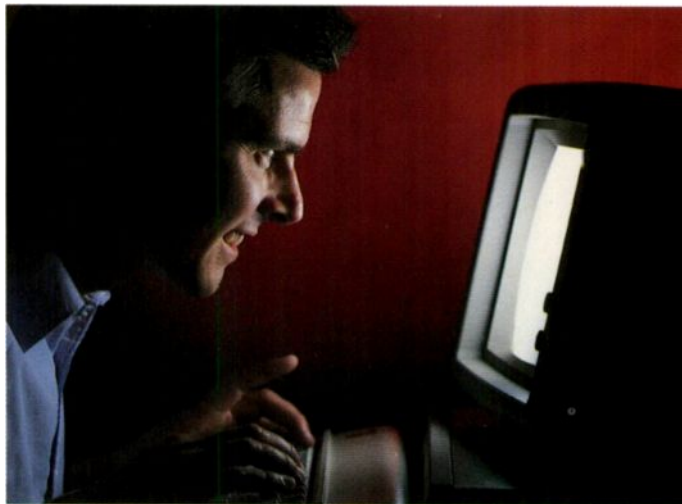

“ Borland International's Turbo Pascal, Turbo Basic and Turbo Prolog automatically identify themselves, by virtue of their 'Turbo' forenames, as superior language products with a common programming environment. The appellation also means to many PC users a 'must have' language. To us Turbo C looks like a coup for Borland.

Garry Ray, PC Week ”

Turbo Basic introduces its powerful new Telecom, Editor and Database Toolboxes

NEW!

Turbo Basic® is the breakthrough you've been waiting for. The same power we brought to Pascal with Turbo Pascal has now been applied to BASIC with Turbo Basic.

Compatible with BASICA, Turbo Basic is the high-performance, high-speed BASIC you'd expect from Borland.

Basically, Turbo Basic is all you need

It's a complete development environment which includes an incredibly fast compiler, an interactive editor and a trace debugging system. It outperforms all its rivals, and because it's compatible with BASICA, you probably already know how to use it.

Includes a free *MicroCalc™* spreadsheet complete with source code. **Only \$99.95!**



A technical look at Turbo Basic

- Full recursion supported
- Standard IEEE floating-point format
- Floating-point support, with full 8087 (math co-processor) Integration. Software emulation if no 8087 present
- Program size limited only by available memory (no 64K limitation)
- VGA, CGA, and EGA support
- Access to local, static, and global variables
- Full integration of the compiler, editor, and executable program, with separate windows for editing, messages, tracing, and execution
- Compile, run-time, and I/O errors place you in the source code where error occurred
- New long integer (32-bit) data type
- Full 80-bit precision
- Pull-down menus
- Full window management

“ Borland has created the most powerful version of BASIC ever.”
Ethan Winer, PC Magazine



Telecom Toolbox is a complete communications package which takes advantage of the built-in communications capabilities of BASIC—use as is or modify.

- Pull-down menus and windows
- XMODEM support
- VT 100 terminal emulation
- Captures text to disk or printer
- PhoneBook file
- 300, 1200, 2400 baud support
- Supports script files
- Fast screen I/O
- Supports most of XTalk's command set
- Manual dial and redial options

Use Telecom Toolbox to embed communications capabilities into your own programs and/or build your own communications package. Source code included for all Toolbox code and sample programs. **Only \$99.95!**

For the dealer nearest you or to order by phone call

(800) 255-8008

In CA (800) 742-1133 in Canada (800) 237-1136



Inquiry 29 for End-Users.

Inquiry 30 for DEALERS ONLY.



Database Toolbox means that you don't have to reinvent the wheel each time you write new Turbo Basic database programs.

- “Trainer” shows you how B+ trees work. (Simply key in sample records and you'll see your Index being built.)
- Turbo Access instantly locates, inserts or deletes records in a database—using B+ trees.
- Turbo Sort sorts data on single items or on multiple keys and features virtual memory management for sorting large data files.

Source code included.

Only \$99.95!



Editor Toolbox is all you need to build your own text editor or word processor. Includes source code for two sample editors.

First Editor is a complete editor ready to include in your programs, complete with windows, block commands and memory-mapped screen routines.

MicroStar™ is a full-blown text editor with a complete pull-down menu user interface, and gives you

- Wordwrap
- Undo last change
- Auto-Indent
- Find and Find/Replace with options
- Set left/right margins
- Block mark, move and copy
- Tab, insert, overstrike modes, line center etc.

Includes source code.

Only \$99.95!

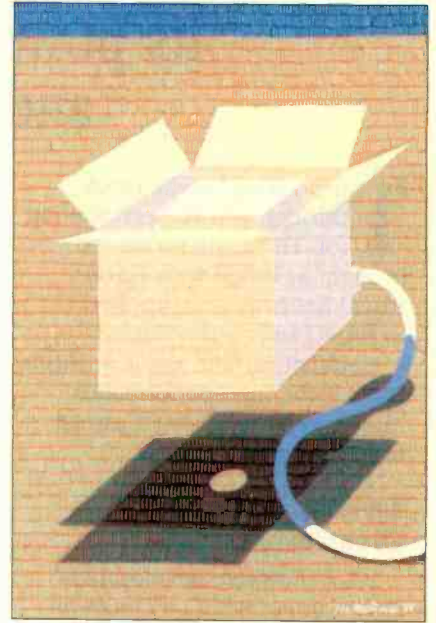

Features/99

Contents

FEATURES	99	Vector-to-Raster Algorithms	177
A Programmer's Introduction to OS/2	101	<i>by Dick Pountain</i>	Disguising vector information as raster data.
<i>by Ray Duncan</i>		Page Printers	187
Writing your first OS/2 application.		<i>by Rick Cook</i>	New developments will help reduce cost and improve resolution.
The New Generation: A Closer Look	110	Print Quality	199
<i>by Richard Grehan</i>		<i>by Lars Jansson</i>	Rating printer technologies requires a set of objective definitions for print quality.
Some surprises about the relative speeds of 80386 and 68020 machines.		Engineering Close-Ups: Taming the Hot Heads	209
Ciarcia's Circuit Cellar: Build the Circuit Cellar AT Computer, Part 1: AT Basics	115	<i>by Keith B. Davenport</i>	Using CAD to design more efficient print heads.
<i>by Steve Ciarcia</i>		Matrix-Line Printing	215
A faster, smaller, and more efficient 100 percent compatible AT CPU board.		<i>by Mark Hohneker</i>	This alternative to a serial moving-head design uses an eight-inch-wide bank of print hammers.
Programming Project: Crafting Reusable Software in Modula-2	123	Color Thermal-Transfer Printing	221
<i>by Hanna Oktaba and René Berber</i>		<i>by Julio Guardado</i>	This process is simple in principle but challenging in its implementation.
Careful program design results in safe, reusable program libraries.		Designing a High-Speed Page Printer Controller	225
Programming Insight: Teaching Old Screens New Tricks	129	<i>by Phil Ellison</i>	This design proves that the controller doesn't have to bottleneck the printing system.
<i>by Michael J. Sorens</i>		Strip-Buffer vs. Full-Page Bit-Map Imaging	229
Create fancy screen displays for your homegrown programs.		<i>by Bert Douglas</i>	This approach minimizes memory requirements.
Constructing an Associative Memory	137		
<i>by Bart Kosko</i>		REVIEWS	235
This nonlinear neural network runs on your PC.		Reviewer's Notebook	236
Karmarkar's Algorithm	146	<i>by Cathryn Baskin</i>	
<i>by Andrew M. Rockett and John C. Stevenson</i>		The Kaypro 386	239
A method for solving large linear programming problems.		<i>by Ray Duncan</i>	This machine delivers two to three times the performance of the IBM PC AT.
THEME: Printer Technologies	161		
Introduction	162		
Color Printing	163		
<i>by Naomi M. Luft</i>			
If the growth of color printing has been slower than expected, it isn't for lack of technologies.			



Themes/161



Reviews/235



Kernel/287

Mail-Order Performance	245
<i>by Frederick D. Davis</i>	
The Proteus-286GT from Proteus Technology and the GV-286 from PC Designs.	
The NEC MultiSpeed	253
<i>by David Satz</i>	
An inexpensive portable with a fast microprocessor.	
The Micro Clipper Graphics Subsystem	257
<i>by Charles Weston</i>	
This two-board subsystem provides enhanced graphics for PC-based CAD systems.	
PC-MOS/386	263
<i>by Richard Grehan</i>	
An 80386 operating system that combines multitasking, advanced task communications, and PC-DOS compatibility.	
Actor 1.0	266
<i>by Leonard Moskowitz</i>	
A fast, memory-efficient alternative to Smalltalk.	
ALS Prolog	269
<i>by Alex Lane</i>	
A Prolog compiler that acts like an interpreter.	
Benchmarking dBASE III Compilers	277
<i>by Malcolm C. Rubel</i>	
Offerings from Nantucket, Wordtech Systems, and Fox Software.	
DESQview 2.00	281
<i>by John McCormick</i>	
Windows, concurrent processing, virtual memory, and more.	
KERNEL	287
Computing at Chaos Manor: In the Chips	289
<i>by Jerry Pournelle</i>	
Fast Kat becomes even faster.	
Applications Only: Potpourri	307
<i>by Ezra Shapiro</i>	
Ezra looks at a database, a telecommunications package, and more.	

LISTINGS

From BIX	285
From BYTEnet	(617) 861-9764
On disk or in print	see card after 256

DEPARTMENTS

Editorial:	6	Ask BYTE	68
Mere Conservatism—		Circuit Cellar	
or Fear, Uncertainty,		Feedback	72
and Doubt?		Book Reviews	81
Letters and		BOMB and Coming	
Review Feedback	12	Up in BYTE	378
Chaos Manor Mail	28	Editorial Index	
Microbytes	37	by Company	379
What's New	45	Reader Service	381
Events	65		

BEST OF BIX

Apple	317
Macintosh	318
IBM PC	324



BYTE (ISSN 0360-5280) is published monthly with additional issues in June and October by McGraw-Hill Inc. Founder: James H. McGraw (1860-1948). Executive, editorial, circulation, and advertising offices: One Phoenix Mill Lane, Peterborough, NH 03458; phone (603) 924-9281. Office hours: Monday through Thursday 8:30 AM-4:30 PM; Friday 8:30 AM-1:00 PM, Eastern Time. Address subscriptions to: BYTE Subscriptions, 262 Old New Brunswick Rd., Piscataway, NJ 08854. Postmaster: send address changes, USPS Form 3579, undeliverable copies, and fulfillment questions to: BYTE Subscriptions, 262 Old New Brunswick Rd., Piscataway, NJ 08854. Second-class postage paid at Peterborough, NH 03458 and additional mailing offices. Postage paid at Winnipeg, Manitoba. Registration number 9321. Subscriptions are \$22 for one year, \$40 for two years, and \$58 for three years in the U.S. and its possessions. In Canada and Mexico, \$25 for one year, \$45 for two years, \$65 for three years. \$69 for one year air delivery to Europe, \$1,000 yen for one year air delivery to Japan, 15,600 yen for one year surface delivery to Japan, \$37 surface delivery elsewhere. Air delivery to selected areas at additional rates upon request. Single copy price is \$3.50 in the U.S. and its possessions, \$4.25 in Canada and Mexico, \$4.50 in Europe, and \$5 elsewhere. Foreign subscriptions and sales should be remitted in U.S. funds drawn on a U.S. bank. Please allow six to eight weeks for delivery of first issue. Printed in the United States of America.

Address editorial correspondence to: Editor, BYTE, One Phoenix Mill Lane, Peterborough, NH 03458. Unacceptable manuscripts will be returned if accompanied by sufficient postage. Not responsible for lost manuscripts or photos. Opinions expressed by the authors are not necessarily those of BYTE.

Copyright © 1987 by McGraw-Hill Inc. All rights reserved. Trademark registered in the United States Patent and Trademark Office. Where necessary, permission is granted by the copyright owner for libraries and others registered with the Copyright Clearance Center (CCC) in photocopy any article herein for the flat fee of \$1.50 per copy of the article or any part thereof. Correspondence and payment should be sent directly to the CCC, 29 Congress St., Salem, MA 01970. Specify ISSN 0360-5280 #3, \$1.50. Copying done for other than personal or internal reference use without the permission of McGraw-Hill Inc. is prohibited. Requests for special permission or bulk orders should be addressed to the publisher. BYTE is available in microform from University Microfilms International, 300 North Zeeb Rd., Dept. PR, Ann Arbor, MI 48106 or 18 Bedford Row, Dept. PR, London WC1R 4EJ, England.

Subscription questions or problems should be addressed to: BYTE Subscriber Service, 262 Old New Brunswick Rd., Piscataway, NJ 08854.

BYTE

EDITORIAL DIRECTOR, BYTE and BIX
Phillip Lemmons

EXECUTIVE EDITOR, BYTE
Frederic S. Langa

ASSISTANT MANAGING EDITOR

Glenn Hartwig
CONSULTING EDITORS
Steve Ciarica
Jerry Pournelle
Ezra Shapiro

SENIOR TECHNICAL EDITORS

Cathryn Baskin, Reviews
G. Michael Vose, Themes
Gregg Williams, Features

TECHNICAL EDITORS

Dennis Allen
Richard Gröhan
Ken Sheldon
George A. Stewart
Jane Morrill Tazelaar
Tom Thompson
Charles D. Weston
Eva White
Stanley Wszola

ASSOCIATE TECHNICAL EDITORS

Curtis Franklin Jr.
Margaret Cook Gurney, Book Reviews

COPY EDITORS

Lauren Stickler, Copy Chief
Judy Connors-Tenney
Jeff Edmonds
Nancy Hayes
Cathy Kingery
Margaret A. Richard
Warren Williamson

ASSISTANTS

Peggy Dunham, Office Manager
Martha Hicks
L. Ryan McCombs
June N. Sheldon

ADMINISTRATION

J. Burt Totaro, Publisher
Beverly Jackson, Publisher's Assistant

ADVERTISING SALES

Dennis J. Riley, Director of Sales
Sandra Foster, Administrative Assistant
ADVERTISING/PRODUCTION (603-924-6448)
Lisa Wozmak, Supervisor
Lyda Clark, Senior Account Coordinator
Marion Carlson
Karen Cilley
Brian Higgins
Wai Chiu Li, Quality Control Manager
Julie Murphree, Advertising/Production Coordinator

MARKETING COMMUNICATIONS

Horace T. Howland, Director (603-924-3424)
Vicki Reynolds, Promotion Manager
Lisa Jo Steiner, Marketing Assistant
Stephanie Warnesky, Marketing Art Director
Sharon Price, Associate Art Director
Julie Perron, Market Research Analyst
Cynthia Damato Sands, Reader Service Coordinator

NEWS AND TECHNOLOGY

Gene Smarte, Bureau Chief, Costa Mesa
Jonathan Erickson, Senior Technical Editor, San Francisco
Rich Malloy, Senior Technical Editor, New York
Nicholas Baran, Associate Technical Editor, San Francisco
Cindy Kiddoo, Editorial Assistant, San Francisco
ASSOCIATE NEWS EDITORS
Dennis Barker, Microbytes
Anne Fischer Lent, What's New
Stan Miastkowski, What's New, Best of BIX

CONTRIBUTING EDITORS

Jonathan Amsterdam, programming projects
Mark Dahmke, video, operating systems
Mark Haas, at large
Rik Jadrnicek, CAD, graphics, spreadsheets
Robert T. Kurosaka, mathematical recreations
Alastair J.W. Mayer, software
Alan R. Miller, languages and engineering
Dick Pountain, U.K.
Roger Powell, computers and music
Phillip Robinson, semiconductors
Jon Shiell, high-performance systems

ART

Nancy Rice, Art Director
Joseph A. Gallagher, Assistant Art Director
Jan Muller, Art Assistant
Alan Easton, Drafting

PRODUCTION

David R. Anderson, Production Director
Denise Chartrand
Michael J. Lonsky
Virginia Reardon

TYPOGRAPHY

Sherry McCarthy, Chief Typographer
Selinda Chiquoine
Donna Sweeney

TELEMARKETING

L. Bradley Browne, Director
Susan Boyd, Administrative Assistant

PLANNING AND RESEARCH

Michele Perron, Director
Falth Kluntz, Copyrights Coordinator

FINANCIAL SERVICES

Philip L. Penny, Director of Finance and Services
Kenneth A. King, Business Manager
Christine Lee, Assistant
Linda Short, D/P Manager
Marilyn Haigh
Diane Henry
Vern Rockwell
Lisa Teates
JoAnn Walter

CIRCULATION

Dan McLaughlin, Director
James Bingham, Single-Copy Sales Manager
Vicki Weston, Assistant Manager
Claudette Carswell, Distribution Coordinator
Karen Desroches, Direct Accounts Coordinator
Louise Menegus, Back Issues

BIX

EXECUTIVE EDITOR, BIX
George Bond

SENIOR EDITOR

David Betz

ASSOCIATE EDITORS

Tony Lockwood
Donna Osgood, San Francisco
MICROBYTES DAILY
Dennis Barker, Coordinator, Peterborough
Gene Smarte, Bureau Chief, Costa Mesa
Nicholas Baran, San Francisco
Rick Cook, Phoenix

Jonathan Erickson, San Francisco

Martha Hicks, Peterborough

Anne Fischer Lent, Peterborough

Larry Loeb, Wallingford, CT

Rich Malloy, New York

Brock N. Meeks, La Mesa, CA

Jeff Merron, Peterborough

Stan Miastkowski, Peterborough

Lynne Nadeau, Peterborough

Wayne Rash Jr., Washington, DC

William Webb, Peterborough

GROUP MODERATORS

David Allen, Applications
Frank Boosman, Artificial Intelligence
Leroy Casterline, Other
Marc Greenfield, Programming Languages
Jim Howard, Graphics
Gary Kendall, Operating Systems
Steve Krenek, Computers
Brock N. Meeks, Telecommunications
Barry Nance, New Technology
Donald Osgood, Computers
Sue Rosenberg, Other
Jon Swanson, Chips

BUSINESS AND MARKETING

Doug Webster, Director (603-924-9027)
Patricia Bausum, Secretary
Denise A. Greene, Customer Service
Brian Warnock, Customer Service
Tammy Burgess, Customer Credit and Billing
TECHNOLOGY
Clayton Lisle, Director
Business Systems Technology, MHIS
Bill Garrison, Business Systems Analyst
Jack Reilly, Business Systems Analyst

PERSONNEL

Cheryl Hurd, Office Manager
Patricia Burke, Personnel Coordinator

BUILDING SERVICES/TRAFFIC

Anthony Bennett, Building Services Manager
Mark Monkton, Assistant
Agnes E. Perry, Traffic Assistant

RECEPTIONIST

Donna Healy

EDITORIAL AND BUSINESS OFFICE:

One Phoenix Mill Lane, Peterborough, New Hampshire 03458, (603) 924-9281.

West Coast Branch Offices: 425 Battery St., San Francisco, CA 94111, (415) 954-9718; 3001 Red Hill Ave., Building #1, Suite 222, Costa Mesa, CA 92626, (714) 557-6292.

New York Branch Editorial Office: 1221 Avenue of the Americas, New York, NY 10020, (212) 512-3175.

BYTEnet: (617) 861-9764 (set modem at 8-1-N or 7-1-E; 300 or 1200 baud). **Fax:** (603) 924-7507. **Telex:** (603) 924-7861.

SUBSCRIPTION CUSTOMER SERVICE: Non-U.S. (201) 837-1315; inside U.S. (outside N.J.) 1-800-423-8272; (inside N.J.) 1-800-367-0218.



Officers of McGraw-Hill Information Systems Company: President: Richard B. Miller. Executive Vice Presidents: Frederick P. Jannott, Construction Information Group; Russell C. White, Computers and Communications Information Group; J. Thomas Ryan, Marketing and International. Senior Vice Presidents-Publishers: Laurence Altman, Electronics; David J. McGrath, Engineering News-Record. Group Vice Presidents: J. Burt Totaro, BYTE; Frank A. Shinal, Dodge; Peter B. McCuen, Communications Information. Vice Presidents: Robert D. Daleo, Controller; Fred O. Jensen, Planning and Development; Michael J. Koeller, Human Resources; Talat M. Sadq, Systems Planning and Technology.

Officers of McGraw-Hill Inc.: Harold W. McGraw Jr., Chairman; Joseph L. Dionne, President and Chief Executive Officer; Robert N. Landes, Executive Vice President and Secretary; Walter D. Serwatka, Executive Vice President and Chief Financial Officer; Shel F. Asen, Senior Vice President, Manufacturing; Robert J. Bahash, Senior Vice President, Finance and Manufacturing; Ralph R. Schulz, Senior Vice President, Editorial; George R. Elsing, Vice President, Circulation; Ralph J. Webb, Vice President and Treasurer.

BYTE, BIX, and The Small Systems Journal are registered trademarks of McGraw-Hill Inc.

HiWIRE™ Starts the Job that smARTWORK® Finishes

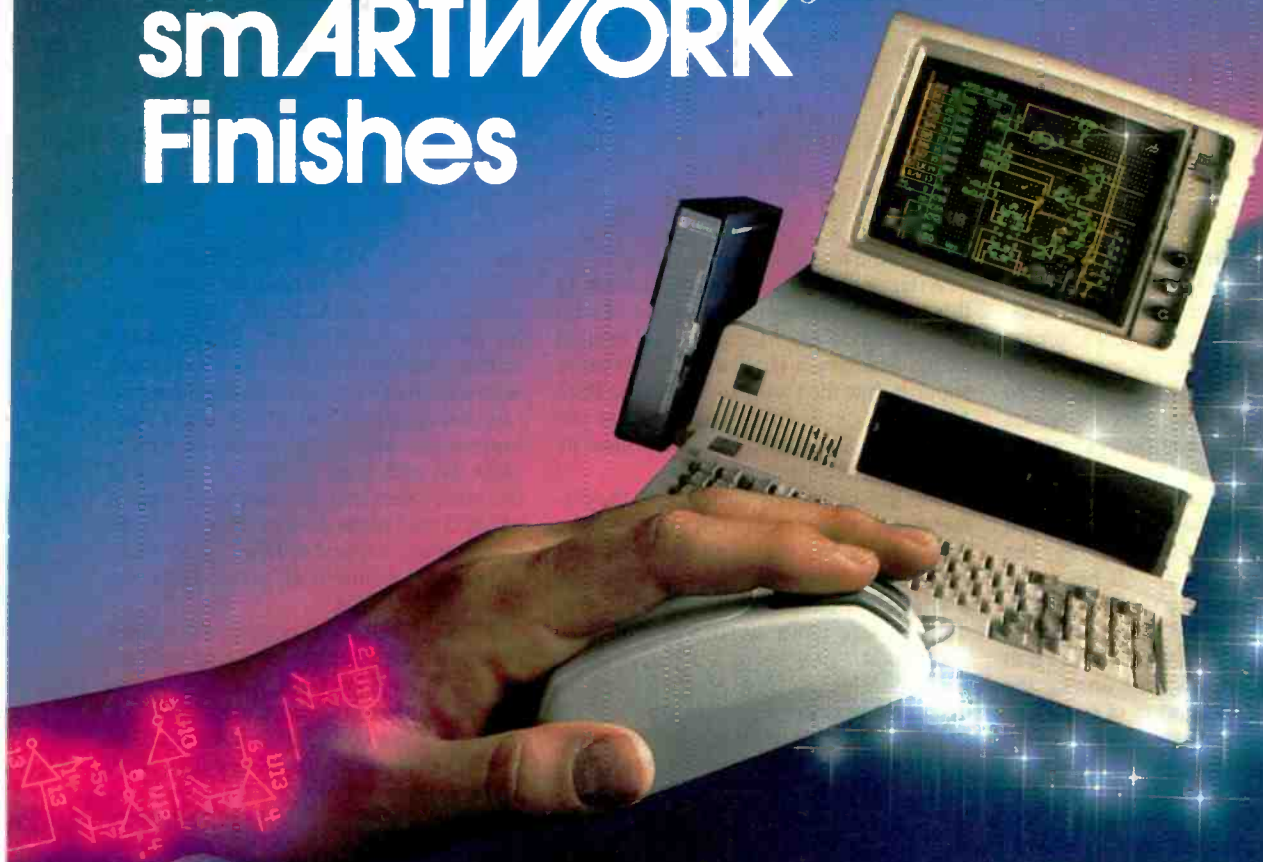

Introducing HiWIRE™

Wintek's smARTWORK® is used by thousands of engineers to design printed-circuit boards. Now Wintek introduces HiWIRE, an electronic-schematic program that is easy to learn and use.

With a click of the mouse button, you can extract symbols from our library of over 700 common components and connect them with wires and buses. You can also easily modify the library's symbols or create your own by combining labels, lines, and arcs.

HiWIRE Advantages

- Easy-to-learn mouse/menu-driven operation
- Complete documentation and tutorial
- Extensive TTL, CMOS, micro-processor, and discrete-component libraries
- Rubberbanding

- Moving, copying, mirroring, and rotating of symbols
- Text-string searching
- Multiple display windows
- High-quality schematics from printers and plotters
- Hierarchical-design support; netlist and bill-of-materials utilities
- Schematic/layout cross checking
- 800 number for free technical support

System Requirements

- IBM Personal Computer, PC XT, or PC AT with 320K RAM, parallel printer port, 2 disk drives, and DOS V2.0 or later
- IBM Color/Graphics Adapter or EGA with RGB color monitor
- Microsoft Mouse
- IBM Graphics Printer or Epson FX/MX/RX-series dot-matrix printer, and/or:

- Houston Instrument DMP-40, 41, 42, 51, 52 or Hewlett-Packard 7470, 7475, 7550, 7580, 7585, 7536 plotter

High Performance at Low Cost

At \$895, HiWIRE delivers quality schematics quickly and easily. You don't need to guess whether or not HiWIRE is right for you. Our money-back guarantee lets you try it for 30 days at absolutely no risk. Call (800) 742-6809 toll free today and put HiWIRE to work tomorrow.

Wintek Corporation
1801 South Street
Lafayette, IN 47904-2993
Telephone: (800) 742-6309
or in Indiana (317) 742-8428
Telex: 70-9079 WINTEK CORP UD



"HiWIRE" is a trademark, and "smARTWORK", "Wintek", and the Wintek logo are registered trademarks of Wintek Corporation.

EDITORIAL

Mere Conservatism—or Fear, Uncertainty, and Doubt?

During COMDEX last June in Atlanta, we conducted a Microcomputer Opinion Poll in the BYTE booth. We asked voters to tell us which machine they considered the best general-purpose microcomputer and which machine they thought would have the biggest market penetration. We asked voters to choose among the IBM PC AT, IBM PS/2 Model 50/60, the IBM PS/2 Model 80, the Compaq 386, the Macintosh II, or "other." (It has to be noted that Apple and many Apple developers pulled out of COMDEX some time ago and that interest in Apple products at COMDEX may be less than among the country's whole population of computer users and developers.) We also asked about preference for operating systems. A lively group of 9154 people came to our booth and voted in the poll. We asked them to identify themselves as end users, consultants, software developers, or hardware developers, and people identified themselves as follows:

end users	42 percent
consultants	37 percent
software developers	37 percent
hardware developers	17 percent

Clearly, many people belonged in more than one category.

Best General-Purpose Microcomputer

The results of the vote on best general-purpose microcomputer were surprising:

IBM PC AT	46 percent
Compaq 386	20 percent
IBM PS/2 Model 50/60	9 percent
Macintosh II	8 percent
IBM PS/2 Model 80	6 percent
All other machines	12 percent

Since our question asked nothing about the prices of machines, we expected most votes to be divided among the three most powerful machines: the Compaq 386, the IBM PS/2 Model 80, and the Apple Macintosh II. Nevertheless, almost half the voters went for the IBM PC AT. Among them, the three most powerful machines got 34 percent of the vote, with the bulk of that going to the Compaq 386—the 32-bit machine that is most familiar and has

been on the market longest.

After seeing the AT's performance in this vote, we recognized that we should have included the Macintosh SE as well as the Macintosh II. If the AT got more support than the Compaq 386 or the PS/2 Model 80, it is quite possible that the Macintosh SE might have outpolled its more powerful sister machine.

Results were fairly even across the different types of voters, but the Compaq 386 got 25 percent of the vote among software developers. The IBM PC AT got a slightly higher vote among hardware developers than across the whole population.

Greatest Market Penetration

On the question concerning which machine will have the greatest market penetration, results were as follows:

IBM PC AT	43 percent
IBM PS/2 Model 50/60	22 percent
Compaq 386	14 percent
IBM PS/2 Model 80	7 percent
Macintosh II	6 percent
All other machines	7 percent

While only 9 percent thought the PS/2 Model 50/60 was the best general-purpose machine, 22 percent thought it would have the greatest market penetration. Among the 32-bit machines, the Compaq 386 again topped the PS/2 Model 80 and the Macintosh II.

Here, the PS/2 Model 50/60 got 25 percent of the vote among software developers as against 22 percent in the whole population. Hardware developers voted for the PS/2 Model 50/60 at a rate of 21 percent, lowest for any group.

Operating System Preferences

The main reason for asking this question, since operating systems often arrive with machines as standard equipment, was to see whether they were ready to embrace OS/2 and whether they expected Unix to gain supporters across different kinds of machines. Here are the results:

MS-DOS	52 percent
Unix	17 percent
OS/2 extended version	15 percent
OS/2 standard version	7 percent
Macintosh OS	5 percent
All other systems	4 percent

As expected, MS-DOS got the lion's share of the vote. It beat the combined vote for versions of OS/2 by 52 percent to 32 percent. Surprisingly, the extended version of OS/2—IBM's own version with mainframe-compatible database and communications facilities built in—topped the standard version of OS/2. Unix did well also, getting 17 percent of the vote, more than the extended version of OS/2 and more than twice as much as the standard version of OS/2. It looks as if some Macintosh II proponents are planning to use Unix.

MS-DOS had fewer supporters among software developers and consultants than across the whole population. Only 45 percent of the software developers and 48 percent of the consultants went for MS-DOS, but 54 percent of the end users voted for it.

Not surprisingly, Unix got 22 percent of the vote from software developers and only 14 percent from end users. The OS/2 standard version was equally popular among the different types of voters, while the OS/2 extended version did a little better among software developers and consultants.

Conclusions, Anyone?

Although computer people often want the best and the latest and the most powerful, most people at COMDEX were reluctant to embrace the new generation of microcomputer hardware and software. True, neither the Macintosh II nor the PS/2 Model 80 was available when COMDEX took place, and that may account for their surprisingly weak showings.

But a larger factor is the unsettled character of the market as everyone waits to see whether IBM will permit PS/2 compatibles to be made under any conditions. There is a bit more receptiveness to OS/2 than to IBM's PS/2 machines: 32 percent of the voters were willing to go with OS/2, while only 15 percent thought a PS/2 machine is the best microcomputer. On the other hand, 29 percent thought the PS/2 machines would have the greatest market penetration.

We'll conduct this poll again in our booth this fall at the COMDEX in Las Vegas and let you know how preferences have changed.

—Phil Lemmons
Editor in Chief

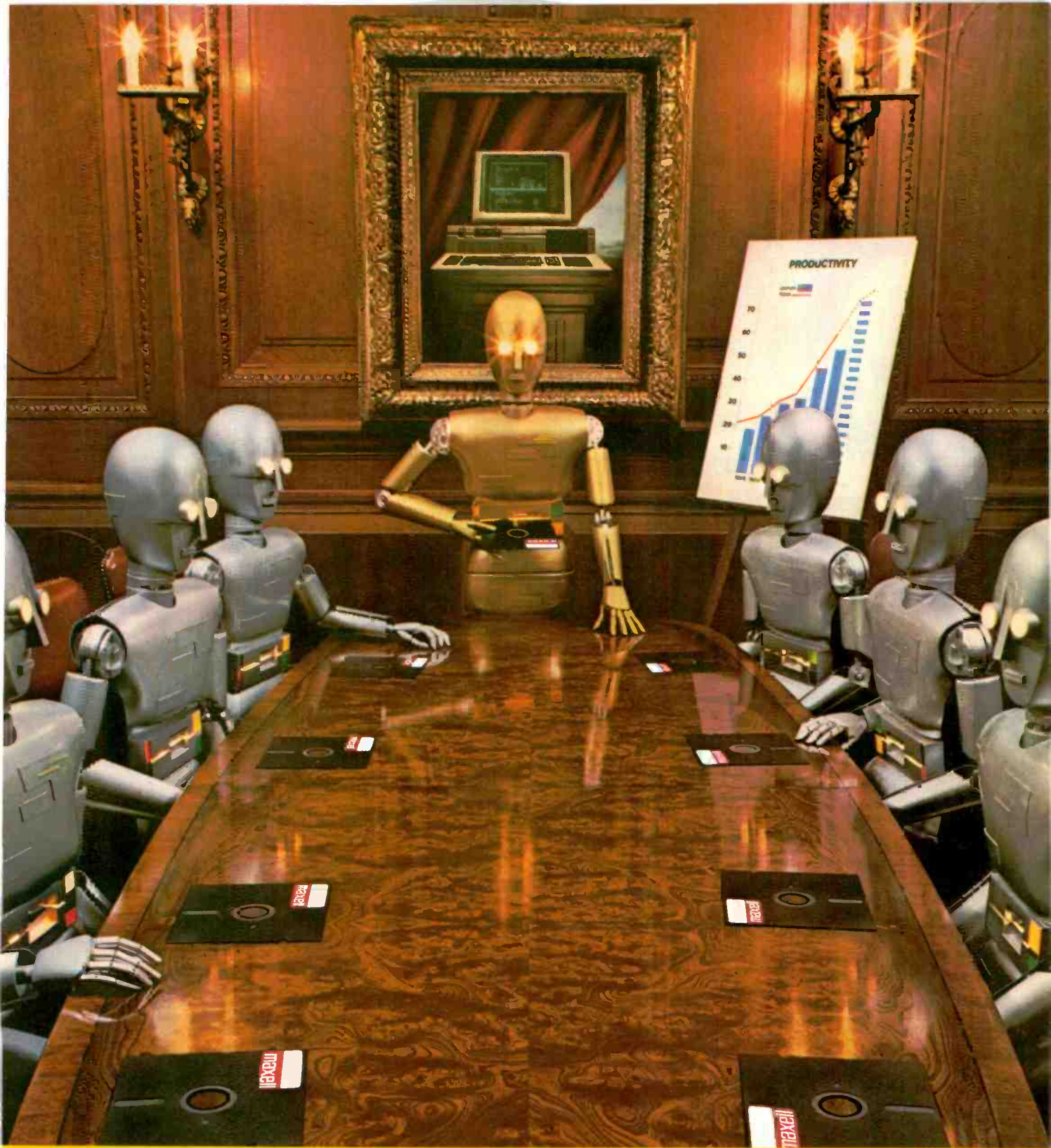

When computers get down to business, they move up to Maxell.

Maxell was first to provide you with a 5¼" high density floppy disk. Just another example of how we keep you a step ahead.



maxell
THE GOLD STANDARD

Ideal Working Conditions



If you're looking for a high-speed laser printer that can easily handle as many as 25,000 pages a month, the new Toshiba PageLaser12® is the machine for you.

It thrives in any high-volume office environment. Whether it consists of a productive single user, or a network of multiple users sharing the workload.

PageLaser12's extended product life might help to explain its hard-work mentality. At up to 1.2 million pages, it's three times more durable than other laser printers.

You'll also have an equal appreciation for its advanced paper handling options. Our Toshiba-made dual-bin paper

feeders, combined with PageLaser12's standard cassette feeder, give you a paper capacity of 750 sheets.

That's 500 sheets more than most other laser printers.

But here's the best part. With three paper feeders, you can now print multiple paper types and sizes automatically. Letter, legal, letterhead, even labels can be accessed with no physical change.

What's more, our optional proprietary envelope feeder lets you print large quantities of envelopes without constantly banging away on your office typewriter.

You can also use the same font style that appears on your letters to create a

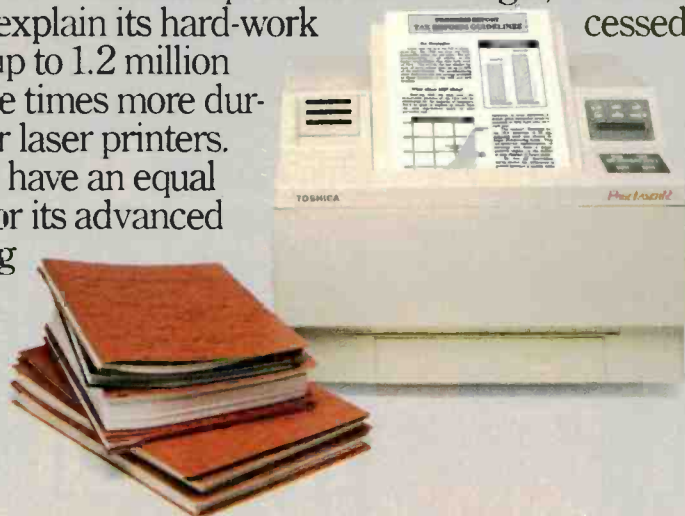

For The PageLaser12.



more professional, unified look.

But don't think for a second all these bells and whistles slow down performance. At 12 pages per minute, PageLaser12 is up to 50% faster than many other laser printers.

As for multiple emulations, HP LaserJet 500 Plus,[®] Diablo,[®] IBM[®] Graphics, Qume[®] and Toshiba P351 all come standard, as do parallel/serial interfaces. There's also a 1.5MB memory option for full-page 300 dpi graphics. And our optional output jogger/collator ensures easy separation of multiple copy output. All of which means PageLaser12 can meet the needs of any office worker.

A complete library of Toshiba font cartridges is available with multiple HP LaserJet-compatible fonts on each cartridge. And

PageLaser12's high-volume capability and low-priced supplies produce one of the lowest desktop laser costs per page in existence.

To top it off, you get all this high-volume ingenuity, speed and flexibility for what you'd expect to pay for a less equipped low-volume laser printer.

So if your business prospers on high volume, get the laser printer that does the same. The PageLaser12.

For more details, call 1-800-457-7777 for the name of the Toshiba printer and computer dealer nearest you.

Then see how well PageLaser12 performs in your surroundings.

IBM is a registered trademark of International Business Machines Corporation. Diablo is a registered trademark of Xenox Corporation. Qume is a registered trademark of Qume Corporation. LaserJet 500 Plus is a registered trademark of Hewlett-Packard.

In Touch with Tomorrow
TOSHIBA

Toshiba America, Inc., Information Systems Division

“The Ada programming language shall be the single, common, high order programming language for...

“...all computers that are integral to, physically a part of, dedicated to, or essential in real time to a performance of the mission of weapon systems...used for specialized training, diagnostic testing and maintenance, simulation, or calibration of weapon systems...used for research and development of weapon systems...Use of validated compilers is required...this directive is effective immediately.”

—DoD Directive 3405.2, 3/30/87.

“...Defense computer resources used in intelligence systems, for the command and control of military forces...all major software upgrades...all other applications (some exceptions) in keeping with the long range goal of establishing Ada as the primary DoD higher order language...waivers to the policy...shall be strictly controlled and closely reviewed...this directive is effective immediately.”

—DoD Directive 3405.1, 4/2/87.

AdaNOW

LETTERS

and Review Feedback

Lyrix Flaws

It was with some concern that I read George R. Allen's review of the Lyrix word processor in the May BYTE. Why would anyone compare a word processor with a text editor? That's like saying that it's easier to use Lotus 1-2-3 than to program each application in BASIC. Lyrix calls itself a word processor, and it should have been compared with word processors.

I use Lyrix 4.0.5 under Xenix 03.01.01 on a Tandy 6000 HD system, so in the following comments I am guilty of comparing oranges with, say, tangerines. But with that admission, I'll proceed.

First, Mr. Allen claims that Lyrix "takes advantage of the file-security capabilities of the Unix environment." Lyrix does no more than acknowledge whether a file is writable or readable. Permission assignments must be made from Unix/Xenix, not from Lyrix.

Second, the spelling checker I have is painfully slow. It also fails to allow on-line additions to the dictionary and does not permit global passing of a correctly spelled nondictionary word. Furthermore, the hyphenation feature does no syllabification, and Lyrix removes any hyphens the writer puts in manually.

Other problems include an inability to send special characters to the printer in mid-line and the lack of an index, table of contents, and footnotes or endnotes.

One serious defect is that Lyrix takes over the function keys and the keypad when you enter the Edit mode. These function-key assignments are useful and contribute much to Lyrix's ease of use; however, when you leave Lyrix, you're left with the function keys unassigned.

Lyrix handles long documents well. Although page-oriented, it flows like a document-oriented word processor, and page breaks are indicated by a dashed line that also gives the page number.

But all in all, Lyrix is not comparable to any of the serious word-processing packages like Microsoft Word or WordPerfect. It doesn't even compare favorably with text editors originating in the TTY age.

David D. Farris
Huntsville, TX

When reviewing a product such as Lyrix, it is convenient to compare it to a heavily

used product of a similar nature that operates in the same environment. In my full-time work, I use one of about eight mainframe Unix systems or one of several Xenix-based PC systems. All these systems use vi as a word processor, even though it is a text editor. At the time that I wrote the review (Fall 1986), none of my associates had any form of word- or text-processing systems other than vi running on their Xenix PCs. For these reasons, I chose to compare Lyrix to vi, if only to show that there is a better way.

I use version 5.0 of Lyrix, and I cannot duplicate your problems with the spelling checker. It is reasonably fast, and I can make on-line additions to the dictionary without any difficulties. I can also perform global passing of words without problems, using the ADD command.

I am not sure if you realize that you have an older version of Lyrix. Version 5.0 does have, for example, footnote and table-of-contents capability. I've experienced none of the problems that you have experienced, and I suggest that you contact SCO for assistance.

—George R. Allen

Lyrix Features

George R. Allen's review of Lyrix in the May BYTE failed to adequately address the program's primary strengths and weaknesses. Mr. Allen says that Lyrix has almost all the capabilities of vi. Since vi has regular expressions and Lyrix does not, Lyrix has almost none of the capabilities of vi. But since vi is a text editor and Lyrix is a word processor, that's as it should be.

However, Lyrix has some amazing features. The primary one is that Lyrix is almost totally customizable; you can add or delete menu options at your discretion. Best of all, the help screens are configurable. This, in addition to the customizable editing commands, means that you can configure Lyrix to look like any word processor you like, and the help screens can reflect the changes. I use Perfect Writer at home, so I configured the editing commands of my copy of Lyrix to reflect Perfect Writer commands.

With all these delights, the Lyrix designers made some strange decisions about the program's functions and capabilities. One of Lyrix's drawbacks is its slow editing speed. Mr. Allen touched on

it a little, but he failed to give it the importance it deserved. For sheer editing speed, probably nothing could beat vi, and Lyrix doesn't even come close.

Other drawbacks have to do with Lyrix's use of rulers to control the various formatting decisions and its lack of defaults (that I could find) in text-spacing for a page. Also, you can use the Delete key for one line only; you must use the arrow keys to get back to the previous line. More disconcerting is Lyrix's tendency to insert new text in the middle of old text when wrapping a line in a paragraph. (These last two flaws are probably defects in my Lyrix terminal-configuration file and not a defect in Lyrix.)

Finally, Lyrix uses dot commands at the beginning of a line to specify options like line spacing. WordStar fans may like this, but it's annoying to the rest of us.

The only major bugs I found have to do with the way Lyrix reformats paragraphs. Lyrix assumes that anything with a period, colon, or semicolon is a sentence and puts two spaces after it. Also, when formatting paragraphs, Lyrix leaves the cursor at the bottom of the paragraph instead of leaving it where it started.

On balance, Lyrix does an adequate job as a word processor. It isn't as fancy as Microsoft Word, for instance, but its flexibility redeems it. Lyrix hasn't seriously challenged the "power" word processors, like WordPerfect 4.2, because its formatting isn't as powerful yet. But due to its modularity, I wouldn't take any bets on how long it will be before Lyrix gives the best DOS-based word processors a run for their money in printer control, if only because of its simplicity.

Darrel W. Riley
Seattle, WA
continued

LETTERS POLICY: *To be considered for publication, a letter must be typed double-spaced on one side of the paper and must include your name and address. Comments and ideas should be expressed as clearly and concisely as possible. Listings and tables may be printed along with a letter if they are short and legible.*

Because BYTE receives hundreds of letters each month, not all of them can be published. Letters cannot be returned to authors. Generally, it takes four months from the time BYTE receives a letter until it is published.

We invented the modem that makes fewer demands on your PC.

The Ven-Tel Half Card™ modem. All the power and speed of our regular modems, but with some major advantages for people who demand versatility from their PC.

Regular modems plug into one of your computer's full-size slots. Just like expansion boards—color boards, graphics cards and memory expanders.

The Ven-Tel Half Card modem is different. It plugs into a short slot, freeing up a long slot so your PC can handle an additional function. And while other modems have about 300 components, ours has 70.

So it not only demands less space from your computer—it also demands less power and generates less heat. Your PC stays cool and stress-free.

Competitively priced, the Half Card modem is available in both 1200 baud and 2400 baud speeds. And it's backed by Ven-Tel's free *five-year* warranty. No other major manufacturer even comes close.

If you make a lot of demands on your PC... demand the less-demanding modem: The Ven-Tel PC Modem Half Card.

Ven-Tel
Modems

Our free 24-page booklet, "How To Select The Correct Modem," contains specific information about our full line of modems. To request your copy, call 800-538-5121. In California, call 408-727-5721.

Inquiry 304

ANTHROCART.™

Compact... a key reason why people like the AnthroCart. A lot of hardware arranged in a little space. Stacked up, not out. Sturdy enough to keep it together.

AnthroCart. High-tech furniture for high-tech equipment. Space saver. Mobile. Rugged.

The AnthroCart is designed for tight spaces. Designed so your workspace is as slick as your hardware.

Call us: 800-325-3841



Supports up to 150 lbs.
All steel frame construction
5½ square foot footprint



**Anthro Corporation
Technology Furniture**
3221 N.W. Yeon St.
Portland, OR 97210
503-241-7114

Anthro Corporation is a wholly owned subsidiary of Tektronix, Inc. Anthro is a registered trademark of Anthro Corporation.

LETTERS

On the issue of whether Lyrinx has most of the capabilities of vi, I think you and I differ on the semantics of the word capabilities. Lyrinx does have most of the capabilities of vi, even though vi is a text editor.

Your comments on the customization features of Lyrinx are correct. I have used the customization features to a much greater extent than I mentioned in the review. This feature is one of Lyrinx's greatest selling points.

I did verify several of the problems that you pointed out, which I had not picked up in my usage. In regard to Lyrinx's speed on my IBM PC, the occasional response problems also appear with vi on my PC, so I don't think that Lyrinx itself has a significant speed problem. I may be a little biased, because the time-sharing systems that I use in my work are extremely slow due to the large number of users. Lyrinx on my PC is faster than my systems at work by a large factor.

—George R. Allen

C, More

In the June C interpreter review, Mr. Unger didn't point out the most obvious advantage to using the C-terp interpreter. When you set up C-terp with your current compiler, C-terp offers exactly the same functions and features as the compiler. This means that you don't have to create two versions of a program, one for C-terp and one for the compiler.

By using C-terp, I can write a 10,000-line program using all the functions of the Microsoft compiler and still run it under the interpreter to find a bug or error. When you're dealing with large programs with long compile times, C-terp is a godsend. If I had to take my 10,000-line program (in 20 to 30 files) and, for example, change all occurrences of `get()` to `getline()`, I could never get a program developed.

C-terp is too expensive if you are only trying to learn C, but it is well worth the money for professional programmers. If you develop serious C programs, once you try C-terp you will never go back.

P. Lyle Mariam
St. Louis, MO

I pointed out in my review that if you have a copy of one of the five C compilers supported by C-terp, you can create a version of the interpreter that uses all the functions that are available with that compiler.

In fact, you can add other library functions to the interpreter using a simple but somewhat tedious procedure; I added the entire Essential Graphics graphics functions to a version of C-terp. It increases the size of the interpreter program and

continued



"THE A★STAR'S CPU PERFORMANCE IS SUBSTANTIALLY ABOVE THAT OF THE IBM PS/2 MODEL 60."

-INFOWORLD



WHO CARES!

For about \$5300, you could own an IBM PS/2 Model 60. But for as little as \$1100, you could own a Wells American A★Star® that can outperform it. Of course, for nearly the same money as an A★Star, you could also own any number of Asian built no-name clones.

But then you wouldn't be getting the exclusive ownership advantages that *only* the A★Star offers. Advantages like an 80286 CPU that runs the new MS OS/2 operating system and can also run at 6, 8, 10, 12, 14 and now...16 MHz! And you wouldn't be getting schematics. (Ours are free!) Or GE/RCA on-site maintenance. Or a no questions asked money-back guarantee. Oh, and there's one more little item you wouldn't get... peace of mind. Wells American has been making microcomputers longer than IBM!

In fact, we've probably been making microcomputers longer than *anybody*!

But hey, who are we kidding? Not everyone cares about quality, reputation, support or serviceability. That's why there are mail-order houses. And, as hard as it is to believe, not everyone cares about money or performance. Maybe that's why there's IBM (and Compaq®...and all the others). But, for computer users who *do* care, there is, fortunately, a vendor who also cares...Wells American. And, we'd like to prove it to you. Call us with the page number of this ad. It's worth a big discount on your next A★Star computer system.

Call today. 803/796-7800. This offer *is* limited.



Corporate Headquarters: 3243 Sunset Boulevard • West Columbia, South Carolina 29169 • 803/796-7800 • TWX 510-601-2645

IBM, OS/2 and PS/2 are trademarks of International Business Machines Corporation.

10 Important Reasons to Use **db_VISTA** for File Management

1. **db_VISTA** is written in C.
2. It's fast, combining B-tree indexing with "network" or direct "set" relationships between records.
3. It's flexible. Use **db_VISTA** as a file manager or a complex database; single-user PC to multi-user VAX with millions of records. Upgrade easily with full compatibility!
4. It's portable. MS-DOS, UNIX, VMS ... see list below.
5. It uses space efficiently. Non-RAM resident; only operative functions are in your run-time program.

And there's more . . .

6. **Royalty-free run-time.**
7. **Complete source code available.**
8. **SQL-based db_QUERY!**
Add fast, C-linkable **db_QUERY** for ad-hoc queries and reports. Build an end-user interface; provide a relational view of the database.
9. **FREE tech support hotline!**
60 days free; for product or application development help. Extended support, consulting, training classes — all available.
10. **30 Day Money-Back Guarantee.**
Full refund if not completely satisfied.

That's just the beginning!
Want more details? Call today!

Order Now. It's easy — simply call toll-free. We'll answer your technical questions and get you started . . . fast delivery.

Call Toll-Free Today!
1 (800) db-RAIMA
(that's 1-800-327-2462)
— OR Call 1-206-828-4636

db_VISTA™ **Royalty Free Prices**

	Object	w/Source
Single-User	\$ 195	\$ 495
Multi-User	\$ 495	\$ 990
VAX Multi-User	\$ 990	\$1,980

db_QUERY prices are the same as above



- **Operating systems:** MS-DOS, UNIX, XENIX, ULTRIX, VMS; more . . .
- **Compilers:** Microsoft, Lattice, IBM, Computer Innovations, Aztec, Turbo C, UNIX, XENIX; more to come . . .
also works with most C libraries!

RAIMA™
CORPORATION

3055 - 112th N.E., Bellevue, WA 98004 USA
(206) 828-4636 Telex: 6503018237 MCI UW

BY97

consequently decreases the size of the source code you can use.

When used in this way, C-terp is a tremendous time saver for developing programs that you will later compile.

—John Unger

C Syntax Checker

I read John Unger's review of C interpreters (June) with great interest. C interpreters are created as program-development and debugging environments, not as compilers, and the error messages they generate are one of the most important issues to consider when selecting one. Mr. Unger deserves particular commendation

for addressing this concern.

As a user of the Microsoft C compiler, I spent hours trying to locate mysterious errors before I realized that the most common mistakes are simple typos, which the compiler usually notices several lines past the place where they actually occur. Frustrated with missing braces and other details, I wrote a program (see listing 1) that performs a quick and rudimentary syntax check on my source code. The exit codes allow the use of this syntax checker in batch files, making the entire compilation even easier.

Jerzy Tomasik
Long Beach, CA

Listing 1: Syntax checker for C source code.

```

/* syntax.c Program running a quick
syntax check on C source code
Version 1.11
J. Tomasik; created 05/23/87
*/
#include <stdio.h>

main( argc, argv )
int argc;
char *argv[];
{
    FILE *fopen(), *infile;
    char c;
    int lbrace = 0, rbrace = 0,
        squote = 0, dsquote = 0, lpar = 0,
        rpar = 0; int rbrkt = 0, lbrkt = 0;
    int bytecount = 0, errorcount = 0;

    if( argc != 2 ) {
        printf( "SYNTAX checker for C
source code, version 1.1 \n
Copyright (C) J. Tomasik 1987,
1988 \n \n" );
        printf( "Usage: syntax
fname.ext \n" );
        exit(1);
    }
    infile = fopen( argv[1], "r" );
    if( infile == NULL ) {
        printf( "Cannot open %s \n",
argv[1] );
        exit(2);
    }

    while( (c=fgetc(infile)) != EOF ) {
        ++bytecount;
        if( c == '{' )
            ++lbrace;
        else if( c == '}' )
            ++rbrace;
        else if( c == '\ ' )
            ++squote;
        else if( c == '\ "' )
            ++dsquote;
        else if( c == '(' )
            ++lpar;
        else if( c == ')' )
            ++rpar;
        else if( c == '[' )
            ++lbrkt;
        else if( c == ']' )
            ++rbrkt;
    }
    fclose( infile );
    printf( "The file length is %d \n",
bytecount );
    if( lbrace != rbrace ) {
        printf( "There are %3d left and
%3d right braces \n", lbrace,
rbrace );
        ++errorcount;
    }
    if( lpar != rpar ) {
        printf( "There are %3d left and
%3d right parentheses \n",
lpar, rpar );
        ++errorcount;
    }
    if( lbrkt != rbrkt ) {
        printf( "There are %3d left and
%3d right brackets \n",
lbrkt, rbrkt );
        ++errorcount;
    }
    if( squote % 2 ) {
        printf( "The single quote marks
are not paired \n" );
        ++errorcount;
    }
    if( dsquote % 2 ) {
        printf( "The double quote marks
are not paired \n" );
        ++errorcount;
    }
    if( errorcount == 0 ) {
        printf( "No errors found, OK to
compile \n" );
        exit(0);
    }
    else
        exit( errorcount );
}

```

continued



CITIZEN

A TRIBUTE TO THE 24-PIN PRINTER.

You're looking at all the printer you'll ever need. For any application you'll ever have.

The Citizen™ Tribute™ 224. A 24-pin dot matrix solution offering superb word processing, spreadsheet, graphics and data processing applications. At a price you'll find surprisingly affordable.

The Tribute 224 delivers true letter-quality printing at 66 cps, correspondence-quality at 132 cps, and drafts at 200 cps (at 10 cpi). In standard or proportional spacing. And optional IC cards enable fonts and emulations to be easily expanded.

You also get high-resolution graphics. A built-in, push-feed, variable-width tractor and automatic paper loading system. Both serial and parallel interfaces for flexible hardware compatibility. Front panel access to most print functions. And compatibility with virtually every major software package.

All this, and it's backed by our nationwide service, excellent documentation, and 12-month warranty.

For more information, call 1-800-556-1234, Extension 34. In California, call 1-800-441-2345, Extension 34.

The Citizen Tribute 224.

There is no higher tribute to 24-pin printing.

©1987 Citizen America Corporation. Citizen, the Citizen logo and Tribute 224 are trademarks of Citizen Watch Co., Ltd.

 **CITIZEN**
Printers that run like clockwork.

Understanding C

In the review of C interpreters in the June BYTE ("Four C Language Interpreters" by John Unger), Mr. Unger lists a single "major shortcoming" of C-terp as "its lack of a built-in library." What is horrifying about this statement is that it shows a fundamental failure to understand the reason for the product's existence.

C-terp is for those who need to develop code for their compilers. It requires you to use the compiler's libraries, because it is trying to limit the degree to which the same source causes different results when run under the interpreter and when compiled by the compiler. In short, C-terp is designed to be a development environment. Indeed, you cannot order C-terp without specifying which compiler you will be using. To fail to understand that you must use your own compiler's library of routines with C-terp is to fail to understand the nature of the product. It's much like complaining that a calculator is a flawed product because it's too mathematical.

There also seems to be a notion that C interpreters are a great way to learn C. Certainly Gimpel Software is not perpetuating that misconception, but the idea exists nonetheless. BASIC is an ideal

learner's interpreted language, because the significant unit in BASIC is the line. It is not idiotic to sit down at a computer keyboard and start writing BASIC to learn it. However, to produce code in a modular language you must understand the structure of the language, the scope of variables, and so on. In C, the words of the language are less important than the structure. Avoiding syntax errors is not the heart of learning C.

At the Eye Research Institute, we recently purchased a site license for C-terp because it is so useful. In particular, it has a good line editor, lets you run quick checks to make sure you didn't leave off a semicolon, and lets you quickly test what actually comes out of a function before developing too much code for easy debugging. Furthermore, C-terp is a dream for, say, graphics-routine development. With C-terp, you can interactively develop what you want to see. In such an application, it's a minor miracle to have your first compiled output the only compiled output.

Tom Clune
Boston, MA

First, let me add the next three words of the sentence that you quoted from my re-

view. The entire phrase is, "its lack of a built-in library of mathematical functions." C-terp comes with a complete built-in library of extremely useful functions and is lacking only in this one specific area—support for math functions. Because both Run/C and Instant-C include mathematical functions in their built-in libraries, I thought it was fair to point out the omission of such functions in C-terp's.

C-terp is designed primarily for use in a development environment as a companion program to a specific C language compiler; this makes its own lack of math functions not as crucial. But C-terp can also be used alone, as a tool to learn C, to test concepts of the language, and to produce useful programs that can run within the confines of its interpreter environment. It is wrong to imply that C-terp must be used with a specific compiler. I agree, however, that any C language interpreter is most useful when it can work with source code that can be seamlessly ported between the interpreter and compiler environments.

I wholeheartedly support your opinion that trying to learn C using a mindset developed in BASIC is a serious mistake.

continued

LOOK!
It's Flowcharting II+!

The ultimate fast track tool—for internal auditors, public auditors, secretaries, engineers, managers and line leads. Performance power WITH A PLUS, for even faster and easier construction, editing and printing of flow charts and org charts.

- Text auto centering
- Smart line mode
- Internal mouse driver
- 10 styles of text font
- Ega support
- Comprehensive, friendly manual

Give your charts the PLUS for only \$229*. Contact your local software dealer—or call us.

PATTON & PATTON
Software Corporation
81 Great Oaks Blvd., San Jose, CA 95119
1-800/672-3470, ext. 897 California
1-800/538-8157, ext. 897 Outside California
408/629-5044 International
*plus shipping. In California add tax.

Excellence in charting the flow of ideas

Everex ASIC Does It Again

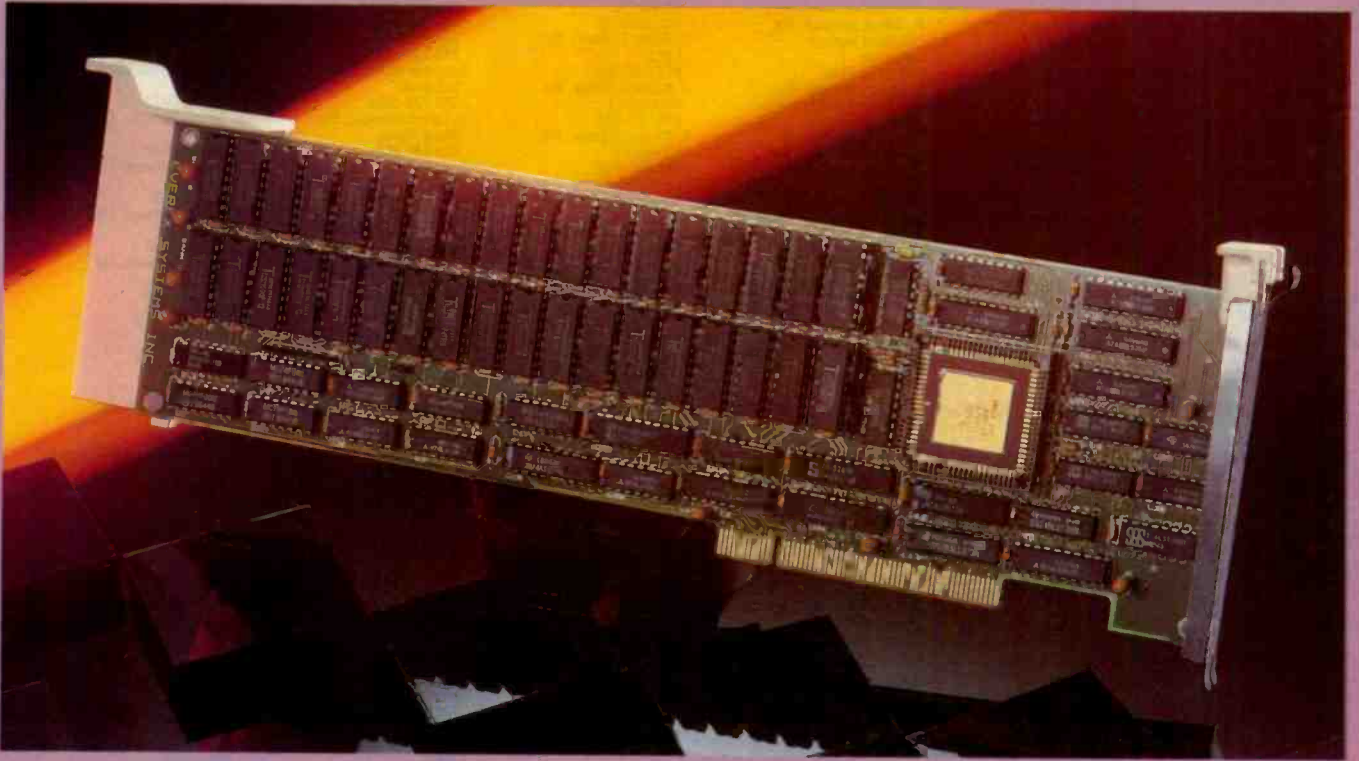

4MB EMS/Extended Memory for PS/2 Micro Channel™

Single Custom Chip

The new Application Specific Integrated Circuit (ASIC) from Everex performs the memory management on the RAM 4000™. The functions of many chips are combined into a single 84 pin chip. This has reduced the total number of components to increase the reliability and create more room for memory. Boost your memory with the RAM 4000 all the way to 4 megabytes!

Flexible for your advantage

There are two banks of memory on RAM 4000. Each bank (18 chips) gives you 2MB. Load either 2MB or 4MB as you need for your application. It is fast, easy and economical.

Configure to your needs

The ASIC chip frees you from restrictions. Allocate a part of the 4MB as EMS memory and the rest as extended. Or you can also dedicate the entire 4MB as either EMS or extended.

More memory for more software

The RAM 4000 lets you run larger spreadsheets with Lotus® 1-2-3®, bigger databases with dBase III Plus™ or run more applications in Microsoft® Windows.

Easy installation

The I/O addressing and memory configuration are done by software so there are no jumpers or switches to set. Just plug the board into the machine and run the computer's setup utility.

Software Partners

RAM 4000 is accompanied by Expanded Memory Manager which manages the operation of all EMS memory, while EDISK lets you use RAM to simulate an extra fast drive. There is also a print spooler that lets you print files while you edit others.

Why wait? For the name of the Everex dealer nearest you call:

(800) 821-0806
in USA

(800) 821-0807
In Calif.

EVEREX
EVER for EXcellence

48431 Millmont Drive
Fremont, California 94538

Everex, EVER for EXcellence, RAM 4000, Personal System/2, Micro Channel, Lotus, dBase III Plus, and Microsoft are registered trademarks of their respective companies. ©1987 Everex Systems, Inc. All rights reserved.

Inquiry 91 for End-Users. Inquiry 92 for DEALERS ONLY.

SEPTEMBER 1987 • BYTE 19

WHERE TO FIND AND BUY LET'S C AND CSD

National
Express Program at
Radio Shack stores

Alabama
Mac Solutions
Huntsville
205-883-4125

Arizona
B. Dalton Software, Etc.
Phoenix
602-996-5772
B. Dalton Software, Etc.
Phoenix
602-943-9723
B. Dalton Software, Etc.
Tucson
602-327-5828

California
B. Dalton Software, Etc.
Bakersfield
805-832-2888
B. Dalton Software, Etc.
Buena Park
714-821-5840
B. Dalton Software, Etc.
Canoga Park
818-348-6030
B. Dalton Software, Etc.
City of Industry
818-912-1079
B. Dalton Software, Etc.
Concord
415-689-7098
B. Dalton Software, Etc.
Cupertino
408-257-5627
B. Dalton Software, Etc.
Escondido
619-747-2175
B. Dalton Software, Etc.
Fresno
209-225-6274

The Computer Edge
Hanford
209-583-1096
B. Dalton Software, Etc.
La Mesa
619-461-5032
B. Dalton Software, Etc.
Los Angeles
213-657-4285
B. Dalton Software, Etc.
Manhattan Beach
213-546-7481
B. Dalton Software, Etc.
Montclair
714-625-1290
B. Dalton Software, Etc.
Northridge
818-993-9167
B. Dalton Software, Etc.
Orange
714-634-1552
B. Dalton Software, Etc.
Orange
714-974-9820
B. Dalton Software, Etc.
Pleasanton
415-460-0966
B. Dalton Software, Etc.
Redondo Beach
213-214-0480

Compuclassics
Resedo
818-705-1895
Cardinal Computers
Riversdale
714-785-6160
B. Dalton Software, Etc.
Riverside
714-687-4613
B. Dalton Software, Etc.
San Bernardino
714-381-6409
B. Dalton Software, Etc.
San Diego
619-291-0154
B. Dalton Software, Etc.
San Diego
619-291-5779
B. Dalton Software, Etc.
San Diego
619-235-4327
B. Dalton Software, Etc.
San Francisco
415-986-2690
B. Dalton Software, Etc.
San Jose
408-270-3445
B. Dalton Software, Etc.
Santa Barbara
805-682-9658
B. Dalton Software, Etc.
Santa Clara
408-246-0802

B. Dalton Software, Etc.
Santa Monica
213-393-7122
B. Dalton Software, Etc.
Sherman Oaks
818-501-6585
B. Dalton Software, Etc.
Sherman Oaks
818-986-4101
Fry's Electronics
Sunnyvale
408-733-1770
B. Dalton Software, Etc.
Torrance
213-371-0157
Software Centre Int'l.
Upland
714-946-5665
B. Dalton Software, Etc.
Westminster
714-892-9020

Colorado
B. Dalton Software, Etc.
Boulder
303-939-9005
B. Dalton Software, Etc.
Denver
303-592-1600
B. Dalton Software, Etc.
Fort Collins
303-226-0880
B. Dalton Software, Etc.
Littleton
303-933-0081
B. Dalton Software, Etc.
Westminster
303-427-9390
Heath Zenith
Westminster
303-429-2292

Connecticut
Computers Etc.
Fairfield
203-336-3100
B. Dalton Software, Etc.
Trumbull
203-372-7882
B. Dalton Software, Etc.
Waterford
203-443-3360
Softown Inc
Watertown
203-274-9227
District of Columbia
B. Dalton Software, Etc.
202-737-7607
B. Dalton Software, Etc.
202-429-9782
ICN
202-775-8188

Florida
B. Dalton Software, Etc.
Altomonte Springs
305-260-6562
Heath Zenith
Plantation
305-791-7300
B. Dalton Software, Etc.
Tampa
813-971-7166

Georgia
B. Dalton Software, Etc.
1159 Northlake Mall
Atlanta
B. Dalton Software, Etc.
Gwinnet Place
Atlanta
714-687-4613
B. Dalton Software, Etc.
San Bernardino
714-381-6409
B. Dalton Software, Etc.
San Diego
619-291-0154
B. Dalton Software, Etc.
San Diego
619-291-5779
B. Dalton Software, Etc.
San Diego
619-235-4327
B. Dalton Software, Etc.
San Francisco
415-986-2690
B. Dalton Software, Etc.
San Jose
408-270-3445
B. Dalton Software, Etc.
Santa Barbara
805-682-9658
B. Dalton Software, Etc.
Santa Clara
408-246-0802

Hawaii
Software Plus
Honolulu
808-538-3344
Illinois
Software City
Arlington Heights
312-259-4260

B. Dalton Software, Etc.
Bloomington
B. Dalton Software, Etc.
129 North Wabash Ave.
Chicago
312-236-0201
B. Dalton Software, Etc.
55 West Monroe
Chicago
312-782-5762
B. Dalton Software, Etc.
645 North Michigan Ave.
Chicago
312-642-5648
Heath Zenith
3466 W. Devon Ave.
Chicago
312-583-3920
S.C.I. Niles
Niles
312-965-9044
Oak Brook Computers
Oak Brook Terrace
312-941-9005

Indiana
B. Dalton Software, Etc.
Glendale Center
Indianapolis
317-251-3198
B. Dalton Software, Etc.
Castleton Square
Indianapolis
317-576-0260
B. Dalton Software, Etc.
Claypool Center
Indianapolis
317-634-3730

Iowa
B. Dalton Software, Etc.
Des Moines
515-278-1030

Kansas
B. Dalton Software, Etc.
Wichita
316-681-1480

Kentucky
Business Computers
and Software
Louisville
502-893-3533

Louisiana
B. Dalton Software, Etc.
New Orleans
504-524-0445

Maryland
Heath Zenith
Baltimore
301-661-4446
B. Dalton Software, Etc.
Cockeysville
Heath Zenith
Rockville
301-881-5420
Sacon Computers
Rockville
301-258-9505

Massachusetts
Computers Solutions, Inc.
Holyoke
413-533-3751

Michigan
Software City
Ann Arbor
313-996-4500
B. Dalton Software, Etc.
Dearborn
313-593-3033
Thompson Electronics
Monroe
313-241-1911
Strom Systems
Plymouth
313-455-8022
Computer Talk
Rochester
313-651-2552
Micro Station
Southfield
313-358-5820
The Software Store
Utica
313-358-5820

Minnesota
B. Dalton Software, Etc.
Brooklyn Park
612-561-6421
B. Dalton Software, Etc.
Burnsville
612-892-3464
B. Dalton Software, Etc.
Edina
612-922-2293
B. Dalton Software, Etc.
Maplewood
612-770-6628
B. Dalton Software, Etc.
Minneapolis
612-332-9008
B. Dalton Software, Etc.
Minnetonka
612-542-3108
B. Dalton Software, Etc.
Rochester
507-282-2706
B. Dalton Software, Etc.
Roseville
612-631-8095

Missouri
B. Dalton Software, Etc.
Clayton
314-863-3324
B. Dalton Software, Etc.
Kansas City
816-763-9656
B. Dalton Software, Etc.
Kansas City
816-361-2620
B. Dalton Software, Etc.
St. Louis
314-968-4505

Montana
B. Dalton Software, Etc.
Missoula
406-721-0320

Nevada
B. Dalton Software, Etc.
Reno
702-825-6665

New Jersey
B. Dalton Software, Etc.
Eatontown
201-542-2285
Heath Zenith
Fairlawn
201-791-6935
Software City
Greenbrook
201-968-4840
Computer Systems
Somerville
201-725-1373
B. Dalton Software, Etc.
Woodbridge
201-855-1999

New Mexico
B. Dalton Software, Etc.
Albuquerque
505-888-9595

New York
Home Software
Albany
518-438-7058
Heath Zenith
Amherst
716-832-3090
B. Dalton Software, Etc.
Bay Shore
516-665-4111
B. Dalton Software, Etc.
Clay
315-458-0163
B. Dalton Software, Etc.
Flushing
718-961-5930
Software Centre Int'l.
Forest Hills
713-793-8112
Heath Zenith
N. White Plains
914-761-7690
B. Dalton Software, Etc.
666 Fifth Ave.
New York
212-315-4744
B. Dalton Software, Etc.
170 Broadway
New York
212-267-7894
B. Dalton Software, Etc.
396 Avenue of the Americas
New York
212-529-6985

B. Dalton Software, Etc.
103 Fifth Avenue
New York
Executive Photo
New York
800-882-2802
Computer Diagnostics
Rochester
716-248-3554
Executive Photo
Scarsdale
914-723-1331
B. Dalton Software, Etc.
White Plains
914-682-8606
B. Dalton Software, Etc.
Yonkers
914-779-8490

North Carolina
Software Express
Charlotte
704-522-7638
B. Dalton Software, Etc.
Raleigh
919-781-4078

Ohio
Heath Zenith
Cleveland
216-292-7553
B. Dalton Software, Etc.
Columbus
614-868-6874
B. Dalton Software, Etc.
Columbus
614-459-6607
Heath Zenith
Springdale
513-671-1115
B. Dalton Software
Toledo
419-475-3884

Oklahoma
B. Dalton Software, Etc.
Oklahoma City
405-634-6601
B. Dalton Software, Etc.
Tulsa
918-663-5454

Oregon
B. Dalton Software, Etc.
Eugene
503-345-1022
Software Express
Eugene
503-342-1298
B. Dalton Software, Etc.
9403 S.W. Washington Sq. Rd.
Portland
503-639-7657
B. Dalton Software, Etc.
Clackamas Town Center
Portland
503-653-9571
B. Dalton Software, Etc.
Downtown at 5th and Alder
Portland
503-241-2500
B. Dalton Software, Etc.
1004 Lloyd Center
Portland
503-249-8672

Pennsylvania
B. Dalton Software, Etc.
King of Prussia
215-337-9151
B. Dalton Software, Etc.
Monroeville
412-373-3207
B. Dalton Software, Etc.
Pittsburgh
412-232-9502
B. Dalton Software, Etc.
Willow Grove
215-657-4669

Rhode Island
Software Center RI
Warwick
401-738-9100

South Carolina
Software City
Spartanburg
803-574-4713

Tennessee
Software City
Chattanooga
615-899-3541

Floppies Discount Software
Knoxville
615-584-5866

Texas
B. Dalton Software, Etc.
Dallas
214-991-8563
B. Dalton Software, Etc.
Dallas
214-744-3423
B. Dalton Software, Etc.
Denton
817-566-6650
B. Dalton Software, Etc.
Houston
713-946-4877
B. Dalton Software, Etc.
Houston
713-682-5933
B. Dalton Software, Etc.
Houston
713-439-1045
Computer Age
Houston
713-977-0722
Software Galleria
Houston
713-890-2222
B. Dalton Software, Etc.
Mesquite
214-681-2586
San Antonio Discount Computer
San Antonio
512-680-5021

Virginia
B. Dalton Software, Etc.
Arlington
703-522-6161
Dominion Software
Chester
804-796-7936
B. Dalton Software, Etc.
Falls Church
703-241-8519
Software Central
Norfolk
804-461-6452
Computer Works
Petersburg
804-861-1010
Software Plus
Richmond
804-285-2170
B. Dalton Software, Etc.
Springfield
703-971-0104
ICN
Springfield
703-569-4141
Software Center
Vienna
703-356-3600
Heath Zenith
Virginia Beach
804-460-0997

Washington
B. Dalton Software, Etc.
Bellevue
206-453-1696
University Bookstore-W.V.
Seattle
206-634-3400
B. Dalton Software, Etc.
Tacoma
206-472-2267

Wisconsin
New Age Tech
Halescorners
414-425-3000
B. Dalton Software, Etc.
Milwaukee
414-272-0185
B. Dalton Software, Etc.
Wauwatosa
414-258-4144

Note: Product availability
may vary at B. Dalton
Software, Etc. stores.

If there isn't a dealer listed in your area, don't give up. Give us a call. Phone 1-800-MWC-1700. In Illinois 1-312-472-6659.

PRESENTING THE DIFFERENCE BETWEEN FAST COMPILING AND FAST PROGRAMMING.

For compiling speed, you can't do better than Let's C. But to really speed up programming you can't do without the powerful source level debugger, *csd*.

If you want the power, portability and flexibility of C, start with the complete compiler, Let's C. For utilities, editor, compiling speed and fast, dense code, Let's C has it all.

But to get your programs up and running you need more. Because even the fastest compiler can't outrun bugs. You need the revolutionary C Source Debugger, *csd*.

CUT DEVELOPMENT TIME IN HALF WITH *csd*

csd lets you bypass the time consuming frustrations of debugging—like long dumps and clunky assembler. With *csd*, you actually debug in C. You learn faster because you watch your program run in C. You finish faster because *csd* combines the speed of a compiler with the interactive advantages of an interpreter. The end result? Development time is sliced in half.

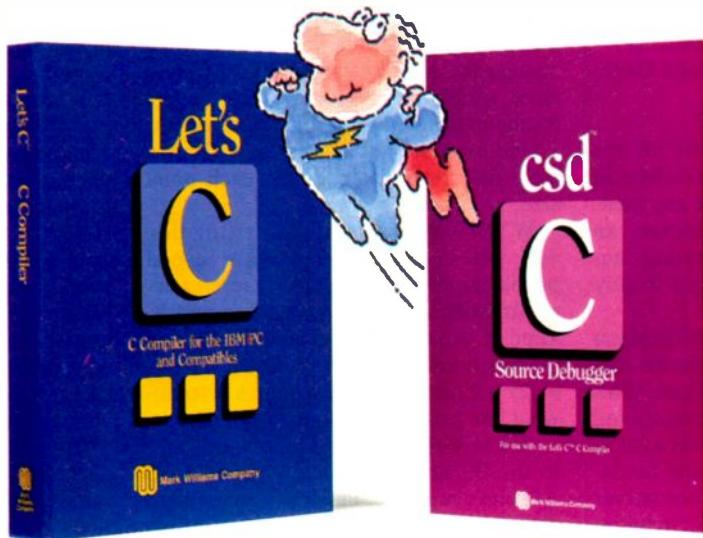

REVIEWERS ARE RAVING ABOUT LET'S C AND *csd*.

"Let's C is an inexpensive, high-quality programming package... with all the tools you will need to create applications."
—William G. Wong, *BYTE*, August 1986.

"The performance and documentation of the \$75 Let's C compiler rival those of C compilers for the PC currently being sold for

\$500... highly recommended..."

—Marty Franz, *PC TECH JOURNAL*, August 1986.

"csd is close to the ideal debugging environment... a definite aid to learning C and an indispensable tool for program development."

—William G. Wong, *BYTE*, August 1986.

"This is a powerful and sophisticated debugger built on a well-designed, 'serious' compiler."

—Jonathon Sachs, *Micro/Systems Journal*, April, 1986

START TO FINISH, THERE'S NO BETTER ENVIRONMENT.

Get started with the right C compiler and you'll have everything you need for development—including source level debugging. On top of it all, Let's C and *csd* are today's best values in professional C programming tools. And most reliable: Mark Williams C compilers have been sold with DEC, Intel and Wang computers since 1981.

60 DAY MONEY BACK GUARANTEE

Mark Williams gives you a full 60 days to find out just how good Let's C and *csd* really are—or your money back.

So if you want more than a fast compiler—if you want your programs up and running fast, ask for Let's C and *csd*. You'll find them at your software dealer's, in the software department of your favorite bookstore, through the Express Program at over 5500 Radio Shacks or you can order now by calling 1-800-MWC-1700.*

*In Illinois call, 1-312-472-6659.



1430 West Wrightwood, Chicago, Illinois 60614

© 1987 Mark Williams Company
Let's C is a registered trademark of the Mark Williams Company
UNIX is a trademark of Bell Labs

**LIMITED TIME OFFER
FREE *csd*
WITH LET'S C!**

LET'S C AND *csd* FEATURES

NEW VERSION 4.0!

Let's C:

- Now compiles twice as fast
- Integrated edit-compile cycle: editor automatically points to errors
- Includes both small and large memory model
- Integrated environment or command line interface
- 8087 sensing and support
- Documentation features new lexicon format
- MS-DOS object compatible
- New make utility
- Fast compact code plus register variables
- Full Kernighan & Ritchie C and extensions
- Full UNIX compatibility and complete libraries
- Many powerful utilities including make, assembler, archiver, cc one-step compiling, egrep, pr, tail, wc
- MicroEMACS full screen editor with source included
- Supported by dozens of third party libraries

- For the IBM-PC and Compatibles
- Not copy protected

Sieve Benchmark

(Compile time in seconds)
Let's C: 2.8 (On 512K 6Mhz IBM-AT)
Turbo C: 3.89 (As advertised)

csd:

- Large and small memory model
- Debug in C source code, not assembler
- Monitor variables while tracing program
- Does not change program speed or size
- Provides separate source, evaluation, program and history windows
- On-line help screens
- Can interactively evaluate any C expression
- Can execute any C function in your program
- Trace back function
- Ability to set trace points
- Not copy protected

MARK WILLIAMS LET'S C AND *csd*. ONLY \$75 EACH.

However, an interpreter's ability to catch syntax errors quickly, which you yourself mention, does make it a useful learning tool for beginning C programmers.

—John Unger

Alternate Approach to DTP

The theme of the May issue of BYTE was desktop publishing; however, nowhere in the articles or charts was there any mention of the PowerText Formatter, an \$89.95 desktop-publishing product announced and shown at PC-Expo in July 1986.

John W. Seybold's view of desktop publishing is but one approach; he dismisses all approaches other than WYSIWYG. But current Macintosh and IBM WYSIWYG software leaves a lot to be desired and suffers from some fundamental problems, and the alternatives may be more cost-effective, both in initial cost and in day-to-day operation in a production environment.

WYSIWYG is really only approximately what you get. The fonts differ from screen to page, and interletter and word spacing differ. What looks nice kerned on the screen can often end up as touching characters on the printout, and what seems to be centered on the screen

may not be when it's printed.

Scaled fonts, such as those of PostScript, do not map onto dots very well. In addition, a good typographer will often change the shapes of letters in different sizes simply because they look better. Mathematics can't do this. As a result, scaled fonts are not as crisp and clear as fonts discretely designed for each point size.

WYSIWYG systems don't function very well in environments where several people supply the copy and where external artwork and halftones have to be factored in. And, at least on the IBM PC and the Macintosh, using WYSIWYG screens to lay out metro-size newspapers is somewhat like painting through a keyhole.

WYSIWYG requires a lot of hardware. In the PC arena, one really needs a PC AT-class machine, an EGA card, a hard disk drive, and a mouse, not to mention the laser printer. Can everyone who needs desktop publishing really afford all this hardware?

WYSIWYG is ideal for flyers and short newsletters. But is it really practical for books of 200 or more pages?

When you strip away the hype from desktop publishing, what you really find is a problem of economics. Typesetting

costs a lot of money. That problem can be addressed by 300-dot-per-inch (dpi) laser printers, at least in typesetting textual material. Page-layout and composition programs have their place, but they are only a part of the typesetting and publishing problem. When the visual aspects of each individual page are as important as the textual aspects, then page-layout programs may be the ultimate solution. However, advertising material, flyers, and newsletters represent only a very small percentage of the printed material produced in this world. Are we to believe that the economic solution to the high cost of typesetting for each and every page printed is to sit in front of a screen with a mouse?

Your theme articles indicated that desktop-publishing hardware costs between \$10,000 and \$15,000, with software running between \$200 and \$800. But consider this: The street price of an HP LaserJet Series II printer is about \$1700, a good set of times roman and helvetica fonts costs about \$155, and the PowerText Formatter costs \$89.95. Inset 2, a graphics-capturing and editing program from American Programmers Guild Ltd., costs \$99, and a clone costs

continued

SURGE PROTECTOR.

Static buildup from the carpet near your computer can put 12,000 volts at your fingertips. When discharged, you only flinch. But your computer's memory can be jumbled, data scrambled, microchips permanently damaged. You can avoid zapping hardware, software, and yourself with Static Guard™

A periodic spray on furniture and carpet around your work station safely eliminates static and lets you avoid the consequences of a 12,000 volt discharge.



ZAP PROTECTOR.

Look for Static Guard™ in supermarkets and drugstores everywhere. Then use our coupon to save 35¢, your data, and your system's RAM and ROM.

MANUFACTURER'S COUPON		EXPIRES 2/29/88	35¢
SAVE 35¢ ON STATIC GUARD™			
<small>Retailer: For each coupon you accept from a customer at a time of purchase for the specified product, Alberto-Culver Company will pay you 35¢ plus 8¢ for handling if you fulfill all the requirements of this offer and agree to furnish stock to cover coupons redeemed. Any other use constitutes fraud. Coupon void if presented through outside agencies, brokers, or those who are not retail distributors of our merchandise. Coupon may not be assigned, transferred or reproduced and is void where prohibited, taxed, or restricted. Customer must pay sales tax. Cash redemption 1/20¢. Offer good only in U.S.A. Send to Alberto-Culver Company, P.O. Box 5912, El Paso, TX 79966. Coupon expires 2/29/88. LIMIT ONE COUPON PER PURCHASE.</small>			
35¢	22400 114025		

WRRROOM.



INTRODUCING FAST FORWARD™ NOW ANY SOFTWARE CAN RUN UP TO 10 TIMES FASTER.

No more doodling while your database goes digging. Or lollygagging while your spreadsheet loads. Or taking five while your word processing program takes forever.

With Fast Forward, any software runs 2 to 10 times faster.

CAN SOFTWARE REALLY DO THAT TO SOFTWARE?

Fast Forward can. Normally, your computer is constantly going to your disk and wading through massive amounts of data.

But with Fast Forward, data is retained in your computer's internal memory. Which is incredibly fast. Much faster than hard disks. Hundreds of times faster than floppies.

FAST FORWARD PERFORMANCE

■ With Fast Forward ■ Without Fast Forward

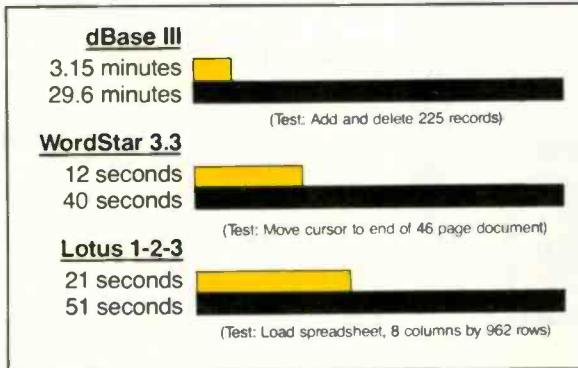

All tests done on 640K IBM PC, 20 megabyte hard disk and floppy drive. 320K RAM allocated to Fast Forward.

THE MORE YOU USE IT, THE FASTER YOU GO.

Once installed, Fast Forward works invisibly. As you use data, it's automatically stored in your computer's memory—and instantly available the next time you need it. Programs requiring frequent disk access (like dBase III) will show amazing improvements. And adding extended memory gives Fast Forward more room to work. So software runs even faster.

PERFORMANCE HAS A NEW PRICE: \$69.95.

You can buy a faster computer. Or an expensive accelerator board. But if you're ready to turn on the speed without turning over a bundle of money, ask for Fast Forward. It's from the Mark Williams Company, makers of quality software tools since 1976. And it's available at your software dealer. In the software department of your favorite bookstore. Or by calling 1-800-MWC-1700.*

And hurry. Because it'll be going fast.

*In Illinois: (312) 472-6659



1430 West Wrightwood
Chicago, Illinois 60614

Fast Forward runs on IBM-PCs and 100% compatibles. Not copy protected.
© 1987, Mark Williams Company



60-DAY
MONEY-BACK
GUARANTEE

FAST FORWARD
60-DAY MONEY-BACK GUARANTEE

less than \$1000. The total is under \$3050—substantially less than \$10,000 to \$15,000. Yet you can do everything with that configuration that a user can do with PageMaker or Ventura. And you can do it faster, with better-looking results.

David P. Guest
Beaman Porter Inc.
Harrison, NY

I stated in the first paragraph of my article that "desktop publishing is a slippery product without a clearcut definition." To explain how it emerged, I traced its

history, uncovering the differences between desktop publishing and computer-aided typesetting. The latter is both narrower (in that it doesn't embrace publishing per se) and also much broader, in that it includes programs and systems that are, at least currently, much more sophisticated in terms of the inclusion of typographic niceties.

It should be clear that desktop publishing currently offers more limited (although very exciting) capabilities. I believe, however, that users at the desktop level will soon be able to command virtu-

ally all the resources of more traditional computer-aided composition capabilities. The much less intimidating interfaces of more traditional approaches are being profoundly modified. WYSIWYG is one such adaptation.

I was not involved with the preparation of Thom Holmes's article, which followed mine in the May BYTE. I did not select, include, or exclude any particular software packages listed there.

But I disagree with your assumption that PostScript, or any other page descriptor language, produces inferior type. The final product depends on the output device.

Nowadays, virtually all new output devices operate in a raster-imaging mode and therefore must deal with the laying down of pixels. It is the responsibility of such languages to output at a resolution within the capabilities of the selected imaging device. (At the desktop level, we are already moving from 300 dpi to much more, and, of course, those who can afford to are using recorders that write their output to photosensitive films or papers.) It is generally not the task of the publishing program to rasterize the output, unless a graphics editing or manipulation package is also included—and even in these cases, final output differs from what you see on the screen. It is true that scaled or even bit-mapped fonts on a video screen do not provide a meticulously faithful representation of final output. However, for review and formatting purposes, they are usually a lot more helpful than monospaced fonts.

The issue that you fail to address is how code-intensive a composition program is or must be. WYSIWYG, by providing a window that permits an interactive preview of the intended output, greatly simplifies the formatting process.

But I do agree that specific features of many WYSIWYG programs may be inadequate for the production of large, relatively standard documents. In such cases, WYSIWYG in and of itself will not provide the hoped-for benefits.

—John W. Seybold

Response to Bonus Issue

I am writing in response to your request for comments on your Summer Applications Software Today special edition. I enjoyed the edition very much.

I use my computers for both productivity and enjoyment. I own an 8-bit and a 16-bit MS-DOS machine, each with hard disk drives. I am more experienced in hardware, as I service computers on a full-time basis for one of the large small-computer retailers. In my spare time, I develop and sell personal robot hardware

continued

How to buy a full-featured laboratory data acquisition, storage, and analysis system for \$30,000 or less.

The multi-pan strip chart (or oscillographic) recorder has been the traditional instrument of choice in many laboratories performing physiological or environmental studies to provide long-term acquisition, monitoring, and storage of data. Many users are familiar with this "old reliable" instrumentation setup, but the cost of this familiarity can be high: The initial price of an oscillographic recorder is from \$15,000 to \$30,000; supplies such as chart paper can cost \$5,000 or more per year; and the system may need to be supplemented with an FM tape recorder that can add upwards of \$15,000 to the total system cost. As these are delicate mechanical instruments, they can suffer from wear and paper or tape jams; pens clog or run out of ink; and a long procedure can produce an overwhelmingly long chart which must be analyzed in detail to locate significant data. Even with this equipment, your data aren't yet digitized for computer analysis. For one must set of later the computer digitize the charts by hand with a dividers and a calibrated scale, data must be entered into a computer either laboriously by hand or with an A/D system that requires specialized knowledge. Either method requires a major investment of time, materials, and/or personnel.

GRAPH and store up to 5,000 samples per second with the System 570 workstation and the new RTMDS (Real Time Monitoring and Data Storage) plug-in card and software. The entire system can be as little as \$7,500—including a PC. No supplies to buy. No separate digitizing of data. Call toll-free (800) 552-1115 for complete information or a demo.

KEITHLEY



NOW SHIPPING!

80386

Imagine the speed and power of a \$100,000 minicomputer in a desktop PC costing under \$7,000. Now imagine all that power going to waste because the operating system you chose was never meant to take advantage of a computer this powerful. It will take more than just a "window environment" or an outdated operating system to unlock the 80386.

It will take PC-MOS/386™.

The First 80386 Operating System. Specifically designed for the 80386 computer PC-MOS/386™ opens doors to more memory and multi-tasking. Doors to thousands of DOS programs as well as upcoming 80386-specific software. It's the gateway to the latest technology... and your networking future.

Memory Management Without Boards. PC-MOS exploits the memory management capabilities built into the 80386. So, up to four GIGABYTES of memory are accessible to multiple users and to future 80386-specific applications requiring megabytes of memory.

Multi-Tasking, Multi-User Support for One, Five or 25 Users. PC-MOS/386™ allows up to 25 inexpensive terminals to be driven by a single 80386 machine. So the features of the 80386 can be utilized at every terminal. And it comes in three versions so you can upgrade your system as your company grows...without having to learn new commands or install new hardware.

UP TO 25 USERS.

MADE FOR THE 80386.

RUNS DOS PROGRAMS.

MULTI-TASKING



Software Support for Thousands of DOS Programs. Although PC-MOS/386™ totally replaces DOS, it doesn't make you replace your favorite DOS programs. So you can run programs like Lotus 1-2-3, WordStar, dBASE III, and WordPerfect on the 80386. Best of all, it uses familiar commands like DIR and COPY—so you'll feel comfortable with our system.

The Gateway to Endless Features. Distinctive characteristics like file/system security, remote access, file/record locking, and built-in color graphics support for EACH user set PC-MOS/386™ apart from all previous operating systems.

Open the Doors to Your Future TODAY! Call The Software Link TODAY for more information and the authorized dealer nearest you. PC-MOS/386™ comes in single, five & 25-user versions starting at \$195.

PC-MOS/386™
MODULAR OPERATING SYSTEM

THE SOFTWARE LINK
Developers of LANLink™ & MultiLink™ Advanced

3577 Parkway Lane, Atlanta, GA 30092
Telex 4990147 SWLINE
FAX 404/263-6174

For the dealer nearest you,
CALL: 800/451-LINK
In Georgia: 404-448-LINK

OEM/Intl Sales: 404/263-1006
Resellers/VAs: 404/448-5465

OEM/Dealer Inquiries Invited

THE SOFTWARE LINK/CANADA CALL: 800/387-0153

**More Than Just Windows,
We've Opened Doors.**

Inquiry 325 for End-Users. Inquiry 326 for DEALERS ONLY.

TRADEMARK ACKNOWLEDGEMENTS: MultiLink® is a registered trademark of The Software Link. PC-MOS/386™, MultiLink® Advanced, and LANLink™ are trademarks of The Software Link. Lotus 1-2-3, WordStar, dBASE III, & WordPerfect are trademarks of Lotus Development Corp., MicroPro, Ashton-Tate, & WordPerfect Corp., respectively. Prices and technical specifications subject to change.

and software. In my full-time work, I handle a lot of software belonging to service customers, so I base my views on that as well as on the software I use for myself.

I was disappointed at your exclusion of FilePro 16 from your database software review. It is much easier to learn and use than the famous dBASE. One of my most important measures of a database program is how easy and inexpensive it is to convert data files from other software and operating systems to the one I use. Although all database software develop-

ers sell conversion programs, I don't like to pay for something I can do myself. I've found that I can write simple BASIC programs (about 10 lines long) to convert anything (including dBASE II and III, TRS-DOS, and Timex-Sinclair) for FilePro 16 use.

Next, a general comment on RAM-resident utilities. These utilities cause almost half of the customer software problems I encounter in my work with MS-DOS machines. The problem is a conflict between the utilities and the primary software. (I have all but stopped

using the utilities myself.) The popular SideKick is a prime offender. The software developers always claim it is a hardware problem. In many cases, it may be a hardware *design* problem, but who cares—if it causes a problem, you can't use it.

In future issues, I would like to see coverage of CAD packages, including math and circuit packages, that most of us can afford (under \$300). I would also like to see continued coverage of desktop publishing, and, again, I'd like it to include the inexpensive products. (I know you recently covered this area, but it's probably the hottest applications area today, and it's changing all the time.)

Just so you know my prejudices, the packages I use most often are WordPerfect, Crosstalk, FilePro 16, PrintMaster, and ClickArt, as well as graph packages and accounting packages. I have never found a need for spreadsheets.

Bruce C. Taylor
Tucson, AZ

Printer Sharing

Share any printer.

Laser, letter quality, plotter, dot matrix, FAX.

Connect any PC/any application.

Even provides a 3287 link between your laser and a mainframe.

Set up is easy.

Reliable and familiar asynchronous connections.

Get going quickly.

Auto-Install program and pop up and use menus help you start work easily and quickly.

Call: 1-800-243-2333; in California: 1-800-247-2006

PrintDirector

Digital Products, Inc., 108 Water Street, Watertown, MA 02172 617-924-1680

PrintDirector is a trademark of Digital Products, Inc.

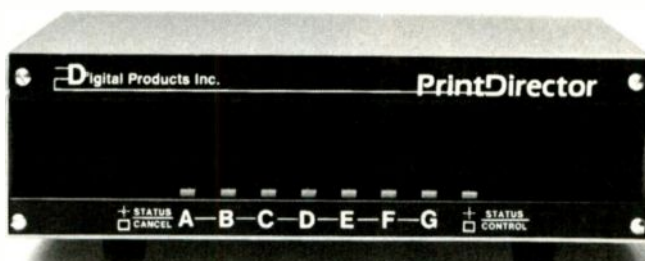

Plain and Simple

OS-9 over Unix

What is the fuss over Apple supporting Unix on the Macintosh II? Both "The Apple Macintosh II," by Gregg Williams and Tom Thompson (April BYTE) and Bruce Webster's "Processor Wars" (According to Webster, June BYTE) mention the coming Unix.

I believe that OS-9/68000 would be a better choice. Also, OS-9/68000 is here today, not just promised like A/UX (or like OS-2 for the IBM PS/2 machines).

Perhaps one of your columnists should do a simple comparison of OS-9/68000 and A/UX.

Ramer W. Streed
Mankato, MN

CAD Appreciation

I enjoyed the article "IGES," by Ralph J. Mayer, in the June BYTE. It was well-written and gave more than just an overview of the intent of IGES and database-exchange problems.

Paul D. Watson
Plano, TX

FIXES

Soft PC

In the May What's New section, on page 44, we incorrectly stated the hardware requirements for Soft PC from Insomnia Solutions. Soft PC is a simulated 8088 IBM PC XT and runs on Motorola-based hardware. It does not require a PC XT, nor does it require an Intel coprocessor. ■



**START
HERE**

**WITH
HOUSTON
INSTRUMENT**

Whether you're a newcomer to CAD or just looking for a reliable, low-cost plotter for your PC CAD system—start here. With the popular Houston Instrument™ DMP-41/42 series plotters.

Priced at \$3,295*, these single-pen plotters give you the features you need for a sensible start—field-tested reliability, C and D size plots, good resolution, a wide selection of plotting media and pens, and compatibility with hundreds of software packages.

Enter the PC CAD world with the DMP-41/42 series—the plotters that offer superb reliability and excellent performance at a very affordable price. Learn about the advantages of

HI's Priority Response Programs featuring a competitive leasing plan and an express service agreement that can replace your plotter overnight.

Begin by calling 1-800-531-5205 (512-835-0900 if in Texas) or writing Houston Instrument, 8500 Cameron Road, Austin, Texas 78753. In Europe, contact Houston Instrument, Belgium NV., Rochesterlaan 6, 8240 Gistel, Belgium. Tel.: 32-(0)59-277445. Tlx.: 846-81399.

**houston
instrument** **AMETEK**
DIVISION

**U.S. suggested retail price. Prices subject to change.
Houston Instrument is a trademark of AMETEK, Inc.*

Inquiry 127



GPIB↔PC



IEEE-488

Interfaces For

**IBM PC/XT/AT
and Compatibles**

**IBM Personal
System/2**

Industry standard GPIB software
for MS DOS and XENIX.

Co-developer of GPIB support for
Lotus Measure, ASYST, LABTECH
NOTEBOOK, and TBASIC.

Software compatible with our
family of IEEE-488 interfaces for
Macintosh, MicroVAX, PDP-11,
LSI-11, VMEbus, STD Bus,
MULTIBUS, S-100 Bus, and
SBX Bus.



**NATIONAL
INSTRUMENTS**

The Leader in IEEE-488

12109 Technology Blvd.
Austin, Texas • 78727-6204

CALL FOR CATALOG

800/531-4742 • 512/250-9119

CHAOS MANOR MAIL

Conducted by Jerry Pournelle

Mousing Around

Dear Jerry,

I am writing in response to your frequent comment that a mouse-oriented word processor seems ill-suited to its basic task. Having just finished writing two books using WordPerfect (now your word processor of choice, I read), I cannot imagine doing any serious editing without a mouse. To be sure, my hands do not seek the company of my keyboard's fuzzy little companion when I am entering large blocks of text, but for re-writing—a deletion here, a rearrangement there—nothing is more helpful than a mouse.

I use Logitech's mouse, finding it vastly superior to Microsoft's. I run MousePerfect as the mouse-interface program. MousePerfect is my own creation—not yet available for sale, although I hope to change that someday. It provides cursor movement, easy deletion, and menu-oriented commands, so you don't have to figure out whether to use the Control key or the Shift key with F6 to get text centered, for example. Of course, the keyboard remains fully available. I would be happy to send you a copy.

Howard E. Abrams
Atlanta, GA

I'd love to see a copy of MousePerfect.

I agree completely: For editing, a mouse is essential, and neither WordPerfect nor Q&A's writer (the other word processor I use a lot on big machines) supports mice. I can't use mice for writing, but it's good to be able to run the cursor around fast when you're trying to rewrite.

Logitech certainly makes the best mice for the money. I tend to use its Bus Mouse addressed to LPT2:, since I'm strapped for ports.—Jerry

Whither the Orb?

Dear Jerry,

In the April 1984 BYTE, you described with great enthusiasm the Omnisphere by Orb Inc. By the time I tried to order one, the company no longer had a telephone number. Edmund Scientific's catalog has a picture of something similar, but they don't have any in stock. Can you direct me to the manufacturer?

Michael Showe
Wayne, PA

The one in the catalog sure looks like the one I have. I have heard these globes are called Star Sculpture, and I will ask on BIX for sources; I bet that I find one.

—Jerry

[Editor's note: According to Microbytes Daily (in the BIX news conference "microbytes"), two exhibitors at the recent CES show had low-cost versions of such "plasma spheres," globes that generate miniature lightning when you touch them. The two companies are: Rabbit Systems Inc., 100 Wilshire Blvd., Santa Monica, CA 90401, (213) 393-9830; and Imaginarium, 3530 North 16th St., Phoenix, AZ 85016, (602) 230-2880.]

The Perfect Word Processor?

Dear Jerry,

I am surprised that you have not used WordStar 2000 Plus. The features that you seem to appreciate most, judging from your reviews of other word-processing software, are available in WordStar 2000 Plus. If you haven't reviewed it because you only review software sent to you by its manufacturer, then I think MicroPro is doing itself a great disservice by not having you try it.

I know several people who once were strong advocates of programs such as Perfect Writer, Microsoft Word, and WordPerfect, but switched after trying WordStar 2000 Plus for a few weeks. Incidentally, it doesn't use the same commands as WordStar; WordStar 2000 Plus uses commands that make more sense, and the screen is WYSIWYG.

One caution: It runs as slow as molasses, especially from floppies. An 80286-based machine is almost a necessity.

Ken Weybright
Cincinnati, OH

I think the problem was that I got WordStar 2000 Plus too early; it seemed interminably slow. I expect that on a Z-248 it would zoom along. Perhaps I should try it, although WordStar 4.0 seems good enough for most purposes and prints rings around most of its competition.

Thanks for the tip.—Jerry

Dear Jerry,

I am baffled by your love affair with WordPerfect. I'm well acquainted with

continued

ASYSTANT+™ ... Menu Driven Engineering And Scientific Software Brings New Power To Your PC!



Data acquisition, analysis, statistics and astounding graphics in one easy to use, integrated and affordable package.

ASYSTANT+ is a software package designed exclusively for engineers and scientists who use a PC as a personal productivity tool. It offers **fully integrated** data acquisition, data analysis and astounding graphic capabilities.

This powerful software is menu driven to get you up and running immediately and provides an interactive and very clear help menu.

Here are just a few of the powerful features:

- A/D, D/A, Data Acquisition and Control
- Full integration to eliminate program shuffling
- Outstanding presentation quality graphics which easily outputs to plotters
- Built-in, ready to run functions include FFT, smoothing, curvefitting, statistics, matrix and polynomial operations... and more

ASYSTANT+ has no equal, either in power or functionality. With this software the time consuming requirements of custom programming are eliminated. With this software you no longer have to settle for "business oriented spread sheets" or multiple programs from several sources. With this

software you can unlock your engineering and scientific potential while expanding your productivity.

ASYSTANT+ is what engineering and scientific software is supposed to be... productive, powerful and capable of handling your toughest assignments.

Best of all, it's easy to install, easy to use and very affordable.

Call us today for more detailed information.

1-800-348-0033 NY-212-702-3241



A division of Macmillan Publishing Company
630 Third Avenue, New York, NY 10017

ASYSTANT + Ready-to-Run Scientific Software is a trademark of Macmillan Software Co.
ASYSTANT + was developed by Adaptable Laboratory Software, P.O. Box 18448, Rochester, NY 14618

the program—in fact, I teach how to use it at a local college—and it has always seemed to be slow and poorly designed (especially the technique for revealing codes in a split screen). I also find the system for selecting options from numbered menus tiresome and frustrating, and I'm surprised you don't feel this way, too. It wasn't so long ago that you wrote a column denouncing bulletin-board software that requires the user to pick an option from a numbered menu. In what way is WordPerfect any different?

I also teach Microsoft Word, and I find it considerably quicker than WordPerfect. I wonder, with your schedule, how much time you really have to try other word-processing programs in any depth. It takes several quiet hours of browsing through the manual to explore a program properly, and, from your column, it sounds as if several quiet hours are a rarity.

Although I teach WordPerfect and Microsoft Word, I don't use them myself. Personally, I feel that PC-Write is still the ideal word-processing program at any price. It certainly comes closest to your expressed ideal of simulating WRITE. (I've tried WRITE on Greg Benson's system, which I understand is identical to yours.)

PC-Write lets you customize your command codes; you can choose any key combination you like to control the functions of the program. It scrolls faster, it searches and replaces faster, and it's infinitely more versatile than the big programs. You mentioned it once in passing; have you ever had time to explore its potential? I think you'd like its design. But everyone has fierce brand loyalties in this business, and I don't suppose mine are any more logical than average.

Over the past few years, I have had the impression that your column focuses more and more on the time spent trying to make hardware items work with one another. I certainly find this myself. Each new purchase provides a whole new series of quirks and bugs to iron out. Things that should be simple often turn out to be ludicrously complicated.

For instance, I wanted to send text from the serial port of an IBM PC to the serial port of a Macintosh. I had the plugs, the cable, and the pinouts for both computers, but it still didn't work. Finally I spent \$39 for a cable from a company that specializes in custom-made cables. It worked on the first try. I opened up the plugs and found the company had shorted pins 5 and 6 together at the IBM end.

How did they know that would work? It's the sort of trick that you never find in a book, and seldom on a bulletin board; and it seems you can't deal with equipment without knowing these little fixes.

Even on the consumer level, systems still cause endless grief. I'm sure you receive plaintive calls for help, as I do, from users who get into trouble and lose a week's worth of text.

I love gadgets, computers especially, but sometimes I wonder if the slow growth in U.S. productivity over the past three or four years is partly due to business people getting diverted from their work and spending hours fiddling around with microcomputer systems, trying to get them to work properly.

I still use a word processor to write fiction, but I use a typewriter for correspondence. It's quicker.

Charles Platt
New York, NY

You're right: It's very hard to do a decent job of evaluating word processors. You have to get used to using them, and that takes some doing.

My problem with Microsoft Word is the lack of commands that do things I want
continued

HARMONY COMPUTERS

2357 CONEY ISLAND AVE., (BET. AVES. T & U) BROOKLYN, N.Y. 11223

ORDER DEPT. ONLY: (800) 441-1144; OR (718) 627-1000; INFORMATION: (718) 627-8888



NO ADDITIONAL CHARGE
FOR CREDIT CARDS

IBM PS II MODEL 50 \$2649.00
STAR NX-10 \$154.00

PANASONIC 1080 I \$149.00
COMMODORE 64C \$148.00

Apple Image Writer II	454
Brother HR 20	324
Brother 1509	349
Brother 1709	454
Citizen 120D	163
Citizen MSP 10	254
Citizen MSP 15	319
Citizen MSP 20	289
Citizen MSP 25	387
Citizen Premier 35	438
Epson LX800	166
LX 86 Cutsheet	24
Epson LQ800	429
Epson LQ 1000	529

IBM	
IBM PS 2 Model 30 (2 Drives)	1240
IBM PS 2 Model 30 (20 Meg.)	1800
IBM PS 2 Model 50 (20 Meg.)	2640
IBM PS 2 Model 80 (40 Meg.)	3000
AT Enhanced IBM 30 Meg. (330)	3240
IBM PC XT	Call
IBM PC XT 286 + 6MHz 640K	3119
1.2 MB, 20 MB Hard Drive	1005
AT Clone 1.2 Meg. Drive	999
Hertz XT (10 MHz) 640K Drive	540
IBM Monitor	219
Toshiba 5 1/4" Disk Drive	120
Toshiba 3 1/2" Disk Drive	179
AST 5 1/4" Pack 384K	199
AST 5 1/4" Pack Premium 256K	130
Hercules Color Card	199
Hercules Monographic Plus	199
NEC EGA 081	289
Quad EGA plus	279
Quad Prosync	279
Video 7 Deluxe	279
ATI Wonder EGA	229
Paradise Auto Switch (350)	229
Paradise Auto Switch (480)	199
Multifunction Card	109
Everex EGA Deluxe (640x480)	199
Everex Edge	199
Everex Graphics Pacer	199
Intel 8087-3	109
Intel 80287-2	169
Intel 80287-4	199
Intel 80287-8	299
Intel 80287-10	299
TOSHIBA PORTABLES	
Toshiba 3100 -	2690
Toshiba 1190 -	1450
Toshiba 1200 -	Call

"PRINTER SPECIALS"

Epson FX 86E	308
Epson FX 286E	429
Epson EX800	369
Epson EX 1000	489
Epson LQ2500	869
NEC 3550	719
NEC 8850	1039
NEC P6	427
NEC P7	599
NEC Color P6	529
NEC Color P7	699
Okidata 182	228
Okidata 192 Plus	327
Okidata 193 Plus	494

SEAGATE HARD DRIVES	
20 Meg. w/controller	319
30 Meg. w/controller	349
30 Meg. AT + 4038	509
40 Meg. AT + 251	489
NEC 20 Meg. Hard Card	359
NEC 30 Meg. Hard Card	429

MODEMS	
Hayes 1200	275
Hayes 1200B w/Smartcom 2	275
Hayes 300	128
Hayes 2400	409
Hayes 2400B w/Smartcom 2	409
Micromodem 2E	125
Prometheus 1200 Internal	138
Everex Internal 1200B	98
Everex 2400 Internal	199
Hayes Smartcom 2	89

NEC	
APC 4 w/20 MEG (Powermate I)	1640
APC 4 w/40 MEG (Powermate II)	2295
NEC Multipend	1340

AT&T	
ATT 6300 Drive, 640K	829
ATT 6300 Plus, 512K, 1.2 Drive	1095
ATT Monitor	199

Okidata 292 w/INTFC	499
Okidata 293 w/INTFC	646
Panasonic KXP 1080 I	149
Panasonic KXP 1091 I	166
Panasonic KXP 1092 I	279
Panasonic KXP 3131	238
Panasonic KXP 3151	369
Panasonic KXP 1592	369
Panasonic KXP 1595	399
Siekosa SP 1200	189
Star NX 10	154
Star NX 10C	154
Star NP 10	134
Star NX 15	299

APPLE	
2GS with 256K	745
Apple Drive (5 1/4)	249
Apple Drive (3 1/2)	329
Mac Plus	1619
MACSE (2 Drives) w/keyboard	2149
MACSE (20 Meg.) w/keyboard	2749
Imagewriter II	454
Apple Color Monitor (RGB)	399
Apple Green Monitor	118

SOFTWARE	
Lokus 123 Ver. 2	299
D Base 3 - Ver. 1.1	375
Franswork 2	381
Symphony 1.2	609
Microsoft Word 3.1	199
Microsoft Windows 1.03	59
Word Perfect 4.2	199
O & A 2.0	199
PFS First Choice	99
PFS Professional Write	109
Norton Utilities 4.0	49
Microsoft Mouse (5.1)	109
Hayes Smartcom II	99
WordPerfect Library	99
Wordstar Professional Ref 4	229
Multimate Advantage Ref 2	239
Bankstreet Writeplus	99
DAC Easy Accounting	49
Venture Desk Top Publishing	458
3 1/2" inch Software	109

Star SD 15 (wide carriage)	299
Star ND 10	309
Star ND 15	359
Star NB 2410	359
Star NB 2415	579
SR 15, SR 10 Sheetfeed	49
Silver Reed Exp 420	189
Silver Reed Exp 800	639
Toshiba 341 SL	679
Toshiba 351 Model 2	849
Toshiba 351 Model 2 Color	1024
Toshiba 321 SL	474

MONITORS	
Amdah 310A	129
Amdah 410A	144
Amdah Color 600S	319
Amdah Color 722	434
Princeton HK 12	284
Princeton NK 12E	432
Princeton Max 12E	129
Scan Doubler	159
NEC Multisync	509
Gold Star TTL Amber	99
Gold Star RGB Color	289
Color Composite	179

COMMODORE	
Commodore 128	218
1571 Drive	212
1670 Modem	199
Commodore 64C	148
1541 Disk Drive	184
1802	199
1902A Monitor	230
MSIP 1000 Printer	189
Star NK 10C	154
Amiga 250K Disk. Mouse	640
Amiga 1080 Color Monitor	279
Amiga 250K Upgrade	139
Commodore PC 10-2, 640K, 2 Drives, Video Card, DOS	619

ATARI	
130 XE	129
653X	97
Atari 801 Printer	179
Atari 804 Printer	179
1050 Drive	158
Atari Writing	37
Atari 1027	109
Atari Modem 301	49

Master Card and Visa welcome. For your protection we check for stolen credit cards. Shipping and handling extra. Defective merchandise will be replaced or repaired at our discretion within the terms of our warranty. All sales final. Price and availability subject to change without notice. We cannot guarantee compatibility.



The most brilliant breakthrough in SQL technology since SQL.

XQL is a dramatic step forward in the history of SQL. It's the one unique SQL solution that helps programmers break through to even higher levels of productivity. Powerful yet easy to use, XQL minimizes your coding time and lets you focus on building better applications.

XQL extends the power of Btrieve, SoftCraft's high-performance file manager, by allowing access to multiple records at a time. It frees your application from physical file characteristics by providing true relational capabilities with data independence, data descriptions, data integrity and security.

XQL's three interface levels are a major advance in SQL technology. The first two levels, XQL primitives

for maximum efficiency or full SQL statements for maximum convenience, are callable subroutines from BASIC, Pascal and C. The third level lets you enter SQL statements interactively without ever having to write a program.

XQL's extensive DBMS features let you access data by name. Field order is independent of physical location within the Btrieve record. Only records that pass your restrictions are returned—in the sort order you specify. Fields can be computed from other fields or constants. And you can manipulate composite records built from multiple, joined Btrieve files.

XQL offers all the performance and reliability you've come to expect from Btrieve, including LAN support, fault tolerance, comprehensive documentation and expert technical support for trouble-free software development.

Plus, you never pay royalties on your XQL applications.

Put the latest innovation in SQL technology to work for you. Contact SoftCraft.



SoftCraft

A NOVELL COMPANY
P.O. Box 9802, #917
Austin, Texas 78766
(512) 346-8380 Telex 358 200

XQL, \$595; Btrieve, \$245; multiuser Btrieve, \$595. XQL requires Btrieve and PC-DOS or MS-DOS 2.X or 3.X. XQL is a trademark and Btrieve is a registered trademark of SoftCraft, Inc.

done fast. There's no "delete word" command, and it's pretty hard to devise a macro to do that. By contrast, WordPerfect has most of the commands I want, and since I run it in DESQview, it's easy to set up a bunch of DESQview macros.

PC-Write is indeed about the best thing PC and XT users can get, and the price is right. What it lacks is some of the built-in conveniences of WordPerfect. I agree, though, that I haven't said enough about PC-Write lately. Everyone ought to have a copy.

In the old days, we used to spend 25 percent above the cost of the computer and peripherals to hire someone for systems integration. It's a bit easier and considerably cheaper now than it was in the 1970s, but we agree that it's not easy enough.

As for correspondence, I find that WRITE on the CP/M Z-80 works quite well, but I'm probably going to change over to the Q&A editor. Running Q&A under DESQview on an 80386 gives some awesome power. —Jerry

Amiga Debate Continues

Dear Jerry,

In the March Chaos Manor Mail, you ended your reply to Warren Block's letter

with, "It's still harder to port to Amiga than Atari."

That claim is not true when you are talking about programs written for high-level operating systems, such as Unix. Any program that runs under Unix can run on the Amiga with almost no changes. The operating system provides primitives that are similar to those found on Unix, and Intuition provides a user interface at least as powerful as the windowing facilities found on most Unix systems. As a result, languages on the Amiga can easily provide the same system constructs found on higher level machines, making it easy to port code from these machines to the Amiga.

If you're talking about porting programs written for machines like the Apple II or the Commodore 64, then yes, you are right. After all, the Atari ST is no different from these computers, except for the replacement of the 6502 with the 68000 and the 64K bytes of memory with a megabyte or more.

The ST hardware is truly wonderful—it's got a 68000 with who knows how many thousand transistors. Unfortunately, the ST is equipped with an operating system as primitive as the vacuum tube. The Atari ST is the only 68000 machine

to limit the number of folders in the system to 40, and the only machine that will not warn the user when such a limit is exceeded.

Keeping all this in mind, it should be clear why it is easier to port programs from an 8-bit microcomputer to an Atari ST than to an Amiga. Take a program written for your favorite 8-bit microcomputer, apply some mechanical translation into 68000 code, and voilà—you have a program ready to run on the ST. The translation doesn't have to be super-efficient. After all, most programs written for the 8-bit microcomputers of the late 1970s and early 1980s are no longer than 64K bytes, and even if the translation expands it by 400 percent, it will still fit within 256K bytes.

What sets the Amiga apart from these 8-bit micros and the ST computers is the multitasking operating system that befits 16-bit 8-megabyte multiprocessor hardware. Why should multitasking make a difference in how easy it is to port to a machine? When you are programming for a multitasking environment, you have to be polite and follow a few rules. Instead of "busy-waiting" (i.e., running in a loop to see if a key is pressed), you

continued on page 314



WHOLE EARTH ELECTRONICS



895.
Free Freight

FREE!
Whole Earth Software Catalog with each CPU purchase!

WHOLE EARTH XT Turbo

Complete 20 MB System
Complete plug-in-and-use system

The Confident Compatible. Superb workmanship. Assembled in our Berkeley California plant and lab tested to ensure quality and compatibility! Each computer gets a 48-hour burn-in.

Features Include:

- Dual clock speed/keyboard switchable 4.77Mhz and 8Mhz • 640K RAM • 150 watt power supply • Eight expansion slots • Runs all MS-DOS programs • BRAND NEW (not refurbished) famous make 20MB hard drive and controller card • 360K famous make floppy drive • AT style 85 key keyboard w/LED status indicators • Monographics (Hercules compatible) card w/printer port • High resolution TTL amber screen monitor • System assembled and tested • FULL ONE YEAR LIMITED WARRANTY • 30-Day return for refund policy • FCC Class B approved

**NO GIMMICKS!
NO HIDDEN COSTS!
PRICES ARE FOR COMPLETE SYSTEMS!**



About Whole Earth Access
"The Company that Calls You Back"™

Whole Earth Access stores, well known throughout California, now sell the finest computer products nationwide. We provide total customer satisfaction at the lowest possible prices. We have 400 employees, we perform over 10,000 customer transactions a week, we do over \$50 million business per year! In all, we have the ability and commitment to take care of our customers.

FOR MORE INFORMATION AND ORDERS CALL TOLL FREE:

1-800-323-8080

For CA calls or customer support: 415-653-7758

WHOLE EARTH ELECTRONICS • 2990 7th Street • Berkeley, California 94710

Call for freight and COD information Errors subject to correction

All returned items must be as new, not modified or damaged, with all manuals, warranty cards and packaging intact. Returned items must bear a Whole Earth Electronics Return Merchandise Authorization on the shipping label to receive a full credit, and must be shipped prepaid and insured. Please call Whole Earth Electronics for more information. **ABOUT OUR WARRANTY:** Whole Earth Electronics will repair or replace, at its option, any defective products or parts at no additional charge, provided that the customer returns the product, shipping prepaid, to Whole Earth Access.

*"Finally,
a Powerful, Easy to Use, Versatile
Sales & Marketing
Program!"*

ONLY
\$99⁹⁵

SALES GENERATOR PLUS

A revolution in automating sales & marketing

SALES GENERATOR PLUS is so easy to use the beginner can amazingly have it running in minutes. The advanced user may be exploring new applications for this complete and powerful program several years from now. It features all the software tools necessary to conduct an effective sales campaign. Right at your fingertips without complicated commands, Sales Generator Plus can automate: Employment & Real Estate Agents • Service Organizations • Legal & Other professionals • Educational Institutions • Medical & Dental • Leasing • Insurance & other services • Consumer and Industrial Product Sales • And many many more.

FEATURES: Menu driven • record capacity limited only by disk space • support contract available • not copy protected • color and monochrome • works with any standard (ACSII) word processor or Sidekick • on demand a customer-by-customer communication history • automatic sales follow-up • telephone follow-up management • User definable reporting • Sales strategies can be defined by department head & follow the critical path of closing a sale • Intelligent record updating option • correspondence follow-up management • target customer selection report • sales performance reporting - daily, weekly, monthly, etc. by region, location, salesman, product or product group • customized on screen script • direct mail management • automatic mailing including conditional mail merging & nesting of data items, sentences and paragraphs • label and envelope printing • definable target market profiles • recognizes standard SIC codes etc. • significant dates • profile of target market and response profile each with 20 definable fields • up to 14 powerful selection criteria & data base ranges.

- appointment management & lists
- automated telephone followup
- import/export interfaces
- selection of sort criteria
- follow-up lists
- name & address lists
- phone lists
- runs on any IBM PC or compatible
- its versatility and features will amaze you.

FOR IMMEDIATE SHIPMENT
In US and Canada

1-800-268-8588

ONLY
\$99⁹⁵ In Hawaii & Alaska:
1-(416)-862-0017
Shipping & Handling \$ 5



SALES GENERATOR PLUS

Supersell Software Inc.
316 California Avenue, #990
Reno, Nevada,
89509

MASTERCARD
VISA
AMEX
DINERS CLUB



Inquiry 281

Trademarks: IBM - International
Business Machines
Sidekick - Borland International



The American Success Story:

\$995

8MHz Mono System

All
New
Pricing



The CLUB 286 is manufactured and serviced in the U.S.A. As a proof of our commitment to quality and performance, we are offering same day shipping, high performance integration. 48 hour burn-in with the most up-to-date Intel parts.

Basic System Features:

- 80286 16-Bit Intel CPU / • AT Style Keyboard
- 512K Motherboard Expandable to 1MB
- 8 Slots (2 8 Bit, 6 16 Bit)
- Clock Calendar with Battery Backup
- 195 Watt Power Supply 110/220V Switchable
- Fully Compatible High Speed AMI BIOS (Written in U.S.A.)
- Full 200 Page Users Guide in a Glossy Binder
- Limited One Year Warranty
- Fully Open Front Face Panel
- Option: • 1.2MB Floppy Drive / • 360KB Floppy Drive
- 2 Hard Disk/2 Floppy Disk Controller / • Enhanced Keyboard
- 1.44MB 3 1/2" and 720K 3 1/2" Drive

Dealers and Corporate inquiries are welcome

(415) 490-2201 FAX 490 2687 (24 HRS)

IBM AT, Xenix, AutoCad, MSDOS, PC DOS, Novell Network, dBASE, Lotus, Sidetick, and Symphony are registered trademarks of their respective companies.

CLUB AT, INC. was founded with the intention to provide the customer with a high quality made in U.S.A. system that suits American tastes at import prices. Try our systems and find out why we have shipped more than 20,000 of them already. Our guarantee stands by you!

To Order a CLUB 286 SYSTEM

Call Our Computer Division from 7:30 AM to 6:30 PM P.S.T.
Or 10 AM to 3 PM P.S.T. on Saturday. Our staff is standing by.

CLUB

American Technologies, Inc.

3401 W. Warren Avenue, Fremont California 94539

Once upon a time, American led the world in innovation, quality, engineering, and manufacturing with names like Edison, Ford, and Bell...

Once Again America returns:



"If Imitation is the sincerest form of flattery, the CLUB AT pays the IBM AT a heartfelt compliment. The only failing of the (CLUB AT) is that it imitates the IBM too accurately...and you can't beat that..."

Karl Koessel PC World
December 1986

Software Compatibility

Xenix, AutoCad, MSDOS, PC DOS, Novell Network, dBASE, Lotus, Sidekick, Symphony and others...

Monitors Optional

CLUB 286 8MHz Mono System \$995

- Basic System Features Plus
- Fully Configured and Tested
- High Resolution 800 x 350, Hercules Compatible 132 Columns
- Monographics Card, Printer Port
- High Resolution 800 x 350 IBM Quality Monitor



With a 20MB 1/2 HT 65ms Drive **\$1295**
With a 30MB Full HT 39ms Drive **\$1495**

CLUB 286 (12MHz Thruput) Mono System \$1629

- Basic System Features Plus /• A 80286-10 CPU
- Fully Configured and Tested /• Hercules Compatible Graphics 132 Columns
- Video Adapter with Printer Port
- A High Resolution IBM Quality 800 x 350 Monochrome Monitor
- 2 Serials, 1 Parallel Port /• Wait State Insertible Slots
- 8/10 Keyboard Selectability /• 12MHz Thruput

With a 30MB Full HT 39ms Hard Disk **\$2129** With a 40MB 1/2 HT 39ms Hard Disk **\$2200**
With a 80MB Full HT 23ms Hard Disk **\$2499**

CLUB 286 8MHz EGA System \$1399

- Basic System Features Plus
- Fully Configured and Tested
- High Resolution Micro EGA Card
- Capable of Mono, Color and EGA
- IBM Quality Monitor (EGA/CGA), 14" Nonglare Screen

With a 20MB 1/2 HT 65ms Hard Drive **\$1699**
With a 30MB Full HT 39ms Hard Drive **\$1899**

CLUB 286 (12MHz Thruput) EGA System \$1995

- Basic System Features Plus /• 80286-10 CPU
- High Resolution 16 Color EGA Card with Mono and RGB Output
- High Resolution EGA Monitor, 14" Nonglare IBM Quality
- Wait State Insertible Slots /• 2 Serials/1 Parallel Port
- 8/10 Keyboard Selectability /• 12MHz Thruput

With a 30MB Full HT 39ms Hard Disk **\$2490** With a 40MB 1/2 HT 39ms Hard Disk **\$2540**
With a 80MB Full HT 23ms Hard Disk **\$2870**

WARROOM

ONLY ORCHID GIVES YOU SO MANY WAYS TO TURBOCHARGE PC ENGINES.

With Orchid's family of turbos, you can get the performance you bought a computer for in the first place. Lightning spreadsheet *recalculations*. CAD screens that *regenerate* in a flash. And large data bases that sort without putting you to sleep.

ORCHID'S TURBO FAMILY

	TinyTurbo 286	PCturbo 286e 10MHz	Jet 386
Host Computer	PC, XT	PC, XT, AT	AT
Reference Speed	3 x XT	6.5 x XT	3 x AT
Accelerator Type	Replaces 8088	Co-processor	Replaces 80286
CPU	8 MHz 80286	10 MHz 80286	16 MHz 80386
RAM	8 K Cache	1 or 2 MB EMS	64 K Cache

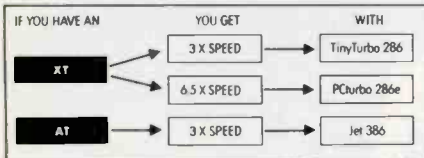

GET THE EDITOR'S CHOICE: TinyTurbo 286™

The TinyTurbo 286™ supercharges your XT to run *three times faster*. Yet it's so small it takes up only half a slot in your computer. Just two reasons why *PC Magazine* named it the Editor's Choice.

TinyTurbo 286 gives you a high level of compatibility. So you can run software like Lotus and Windows—with EGA graphics, EMS memory, or networking cards—at AT speed. You can even go back to your PC's regular 8088 chip, which remains in the system, giving you 100% hardware compatibility.

ADD AWESOME PERFORMANCE: PCturbo 286e™

For power users, the front runner today in accelerators is clearly the PCturbo 286e™. It revs up to *6.5 times faster* than an XT, or up to *2 times* AT speed—giving you the world's fastest screen I/O. Plus the PCturbo 286e comes factory equipped with 1 Megabyte of fast RAM, expandable to 2.

The PCturbo 286e is also a powerful tool for developers and systems integrators. With features like an optional 10-MHz 80287 math chip, and coprocessing software for concurrent foreground/background tasks, the PCturbo 286e lets you build minicomputer-like performance into standard PCs.

MOVE YOUR AT UP TO 386 HORSEPOWER NOW: Jet 386™

Take a look today at the price/performance leader in desktop computing: the Jet 386™. Depending on the application, it's up to *three times faster* than an AT. And *twice as fast* as some high-performance minicomputers. Yet you don't have to buy an expensive 386-based computer to get this kind of horsepower.

More importantly, the Jet 386 uses next generation technology, the 80386 microprocessor. So you can run all of the current software for the AT now, and 386 software too. Add a Jet 386 to your AT today, and you can extend the life of your investment—for a fraction of the cost.

FROM THE COMPANY THAT STARTED IT ALL.

Orchid introduced the first turbo for PCs, and has since become the number one supplier of PC accelerators. For details on our full line of accelerators, graphics, networks and multi-function cards, call (415) 683-0300 today. Or contact your local dealer.



TinyTurbo 286, PCturbo 286e and Jet 386 are trademarks of Orchid Technology. All other product names are trademarks of their manufacturers.
ORCHID TECHNOLOGY
45265 NORTHPORT LOOP WEST
FREMONT, CA 94538
(415) 683-0300; TLX 709289.

TinyTurbo 286:
3 Times XT Speed

See us at PC EXPO
September 1-3
at Booth 961

PCturbo 286e:
6.5 Times XT Speed

Jet 386:
3 Times AT Speed

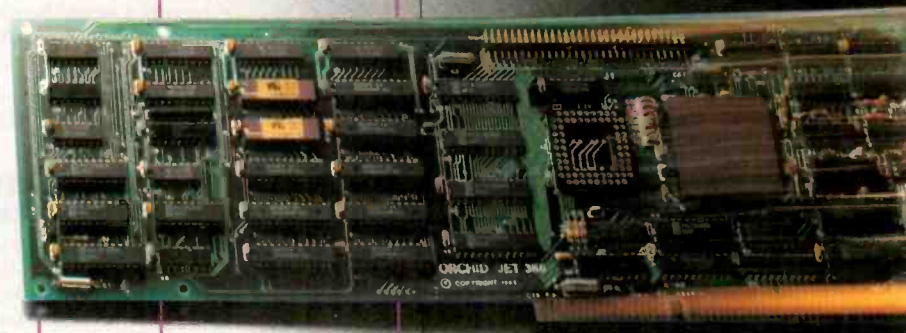
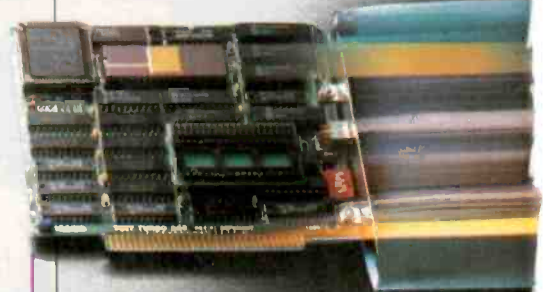

3 x AT

6.5 x XT

3 x XT

MICROBYTES

*Staff-written highlights of developments
in technology and the microcomputer industry.*

Chip Makers Criticized for Bad Attitude

The U.S. semiconductor industry has lots of problems, Intel Fellow Gene Meieran told attendees at a recent conference on electronic materials and processes. But those problems are less the result of lagging technology and more the fault of manufacturers' poor attitudes, primarily toward vendors, customers, and, to some degree, their own products. "Manufacturers are going to have to change," Meieran said, "but that change is not one of technology; it is a change of attitude."

"We are way ahead [of the Japanese] in technology," Meieran said, "but we go around shooting ourselves in the foot." He pointed to one example after another of how U.S. chip makers are self-destructive, paying particular attention to the traditional adversary relationship between manufacturers and vendors, as well as between manufacturers and customers. "Anybody who looks at the vendor or customer as an adversary will not make it," he said.

Meieran used as an example the different attitudes of U.S. and Japanese vendors that Intel encountered when looking for a specific semiconductor. "The U.S. vendor asked us what we wanted, why we wanted it, and tried to tell us we didn't know what we were

doing," he said. "The Japanese vendors didn't say anything, but went back to their engineers and worked on them instead. Six months later we had sources from two Japanese companies."

As part of their attitude adjustment, U.S. manufacturers have to begin sharing information with suppliers and customers, Meieran said, even secret and proprietary information, no matter how painful it is. "However, sharing plans and information goes both ways," Meieran told *Microbytes Daily*. "If a customer wants more control, the customer must be willing to pass certain information back to the manufacturer."

An outgrowth of these attitudinal shifts will be greater partnerships between manufacturers and customers, partnerships like the agreements between Intel and IBM. "We [Intel] look at partnerships as being very important," he said. However, such partnerships will be made at a cost to manufacturers who supply second sources. "The really big change [in the semiconductor industry] will be in the reliance upon sole sources," he said. "Many companies are moving to single-source vendors, and many suppliers will disappear off the face of the earth."

A Look at Apple's Cray Simulation Engine

Apple Computer (Cupertino, CA) has been using its Cray XMP-48 supercomputer, part of a \$20 million installation operated by its Advanced Technology group, primarily as a simulation engine for designing new visual interfaces. *Microbytes Daily* reporters Nick Baran and Jon Erickson recently got a tour of the facility and filed this report.

The Cray consists of four CPUs operating at 9.5 nanoseconds per cycle, 8 million 64-bit words of program memory, and 8 million words of I/O-buffer memory. The I/O system supports multiple 50-megabit-per-second channels (called Hyperchannels) and one high-speed channel operating at 850

megabits per second (called the HSX channel). For storage, the system includes eight 1.25-gigabyte drives, for a total of 10 gigabytes, and several tape-backup systems.

The HSX channel is connected directly to a high-performance frame-buffer system from a young company named Ultra Corp. (San Jose, CA). The Ultra frame buffer allows graphics images from the Cray to be displayed directly on a CRT. According to Sam Holland, manager of advanced technical projects, Apple is the first company that Cray has allowed to access the HSX channel directly. In fact, Apple is the only company to use the Cray in an actu-

continued

Nanobytes

One industry analyst, in an interview about Intel's single-sourcing the 80386 chip, told us that "IBM has the right to manufacture the 386 and even change the microcode, and you can damn well bet they will, probably within the next couple of years." . . . **Texas Instruments** (Austin, TX) has stopped making its TI Professional but is offering owners of that machine an upgrade to the TI Business Pro, an IBM PC AT compatible that can be converted (with a new motherboard) to TI's System 1000 series of multiuser machines. TI will support Professional owners with service and parts for at least five years, said TI's Cindy Smith. She said TI is the first microcomputer company to "offer an alternative other than saying we're stopping production." If you're interested in trading in for a Business Pro, phone (800) 847-2787 or write to TI, 24510 Highway 290, Attn. TIPC Upgrade, Cypress, TX 77429. . . . **Dave Winer**, president of **Living Videotext**, offered this tip for someone in search of a hot new product.

"A conferencing scheduling program for a network would be a hot idea," he said, "as would a slide-maker setting on a network, just like a LaserWriter does today." . . . **The Association of Shareware Professionals** has formed to help shareware developers market their products, broaden distribution, provide a forum for exchanging ideas, and "foster a high degree of professionalism" by setting standards for authors to follow. Co-chairmen are Jim Button (PC File) and Bob Wallace (PC Write). You can contact ASP at 11058 Main St., Suite 225, Bellevue, WA 98006. . . . **Desktop publishing**, once a job for one per-

continued

son, is now becoming a departmental task, Aldus president **Paul Brainerd** said at a recent seminar on that subject. In many publishing situations, groups of people are working together on documents, he said. He also said that the real cost of desktop publishing is not hardware or software, but training. A common software system running on various hardware, though, would reduce those training costs, Brainerd said. . . .

"We intend on putting **Paradox** in as many environments as possible," **Ansa** president **Ron Posner** told *Microbytes Daily*. "Specifically, we are looking at the Macintosh environment, Unix, and SQL." . . . **Generic Software** vice president **Ken Goodman** said the company will "test the waters" with CAD software for the Macintosh, releasing its \$49.95 **FirstCADD** for the Macintosh in time for **COMDEX** in November. . . . **The Potomac Electric Power Company** is offering its customers in the Washington, DC area uninterruptible power supplies to help solve "dirty power" problems. According to **PEPCO**, the UPSs will provide from 5 to 15 minutes of power, enough time to save data gracefully. Leasing cost is \$12 a month. . . .

Commodore Business Machines is offering a special deal to schools: Buy three Amigas for the price of two. The educational discount can be applied to the A500, A1000, or A2000. . . . Calling it "a natural fit," **Atari** is going to start selling its MIDI-equipped ST line of computers in music stores. . . . **The Smithsonian Institution** and **American Interactive Media** will be distributing some Smithsonian publications as Compact Disc-Interactive programs. The first CD-I volume, scheduled for next year, will be based on a book called *Treasures of the Smithsonian* and will cover 300 of the museum's artifacts, including the Apollo 11 space capsule. . . .

Graphic Software Systems (Beaverton, OR) is offering OEMs windowing software based on the **X Window** system (version 11) developed at MIT. Named

continued

al interactive environment, according to Holland.

The Hyperchannel connects the Cray to several networks of Apple Macintosh computers via a VAX-11/785, a VAX-11/780, and a Sun/2. The Macintoshes are linked to the VAXes and Sun/2 via AppleTalk in series with Ethernet. A converter system from Kinetics Inc. bridges Ethernet and AppleTalk. Users log into the Cray from a Macintosh via a micro/mainframe package from Pacer Inc. Once the user is logged in, the Macintosh performs as a remote terminal of the Cray. The Cray uses the Unicos operating system, which is Cray's licensed version of Unix Version V.

In addition to the Macintosh network, a Silicon Graphics system for high-speed animation is connected to the Cray via the Hyperchannel. Animation is primarily used to simulate high-speed video-interface scenarios on the Macintosh and future machines.

According to Holland, the system will soon include a VME board operating at 50 megabits per second, connecting a Macintosh II directly to the Cray. "Eventually, we'll have keyboards and mice connected directly," said Holland. Another objective is to have Ethernet talking directly to the

Cray, thus bypassing the VAXes and Sun/2. "The aim is to get an Ethernet channel directly into the Cray without going into the Hyperchannel," said Holland, adding that "we want to get away from the morass of front ends." At present, about 200 users have access to the Cray and only about 10 use the system at one time. However, the system utilization is generally around 90 percent because of Apple's CPU-intensive graphics simulations.

Two full-time software engineers from Cray work at the Apple facility, in addition to a full-time maintenance engineer. Two separate soundproofed rooms contain three 440-volt power transformers and motor generators, two three-stage cooling water chillers, and a unit that pumps freon into the Cray's cooling jackets. A software system will automatically power down the Cray in the event of a cooling malfunction. A cooling tower, located outside the building, supplies water for the chillers.

Although Apple has yet to release a product fully simulated on the big machine, the Mac II's NuBus was verified on the Cray. Holland speculated that it will be about two years before the release of a product engineered and simulated from scratch on the Cray.

Neural Computing Not Just for the Very Rich

If you want to learn more about neurocomputers—computers designed according to models of how the brain handles information—and parallel processing, but are wincing at the \$10,000-and-up price tags, here are some relatively inexpensive products that you might want to investigate. These products were all shown recently at the International Conference on Neural Networking in San Diego, California.

MacBrain is a Macintosh program from **Neuronics** (Cambridge, MA) for simulating neural networks. **Matt Jensen**, who developed the software, claims it's the only neural net simulation environment to sell for less than \$10,000; in fact, it sells for \$250. It's aimed at people beginning to explore neural networking, as well as those who already have a grasp on the technology.

"Our first target market is made up of the low-end, nontechnical people," said Jensen. "Primarily that includes students, grad students, psychologists, and noncomputer people working on fringe fields that have some overlap into neural-network theory and its applications. It's for the sort of

people who don't want to get too heavily involved in mathematics but just want some idea of what this technology can do for them, and want some results they can see visually."

The version of the program for "hard cores" can best serve "as a simple prototyping tool," Jensen said. "It is very quick and easy to get things up and running and to adjust parameters interactively."

MacBrain runs on the Macintosh Plus, SE, or II. It contains an interpreter and paradigm shells and lets you create your own multiple paradigm shells. It is equipped to simulate adaptive resonance, the Delta rule, Boltzman machines, and Hopfield nets. An August update is set to support transputer-based boards. That version also offers two programming languages, one text-based and one graphics/icon-based, so people can do their own types of paradigms and rules.

If you are a developer looking to get involved with generalized parallel processing, you might want to check out the **Parallon** parallel-processing board from **Human Devices** (New

continued

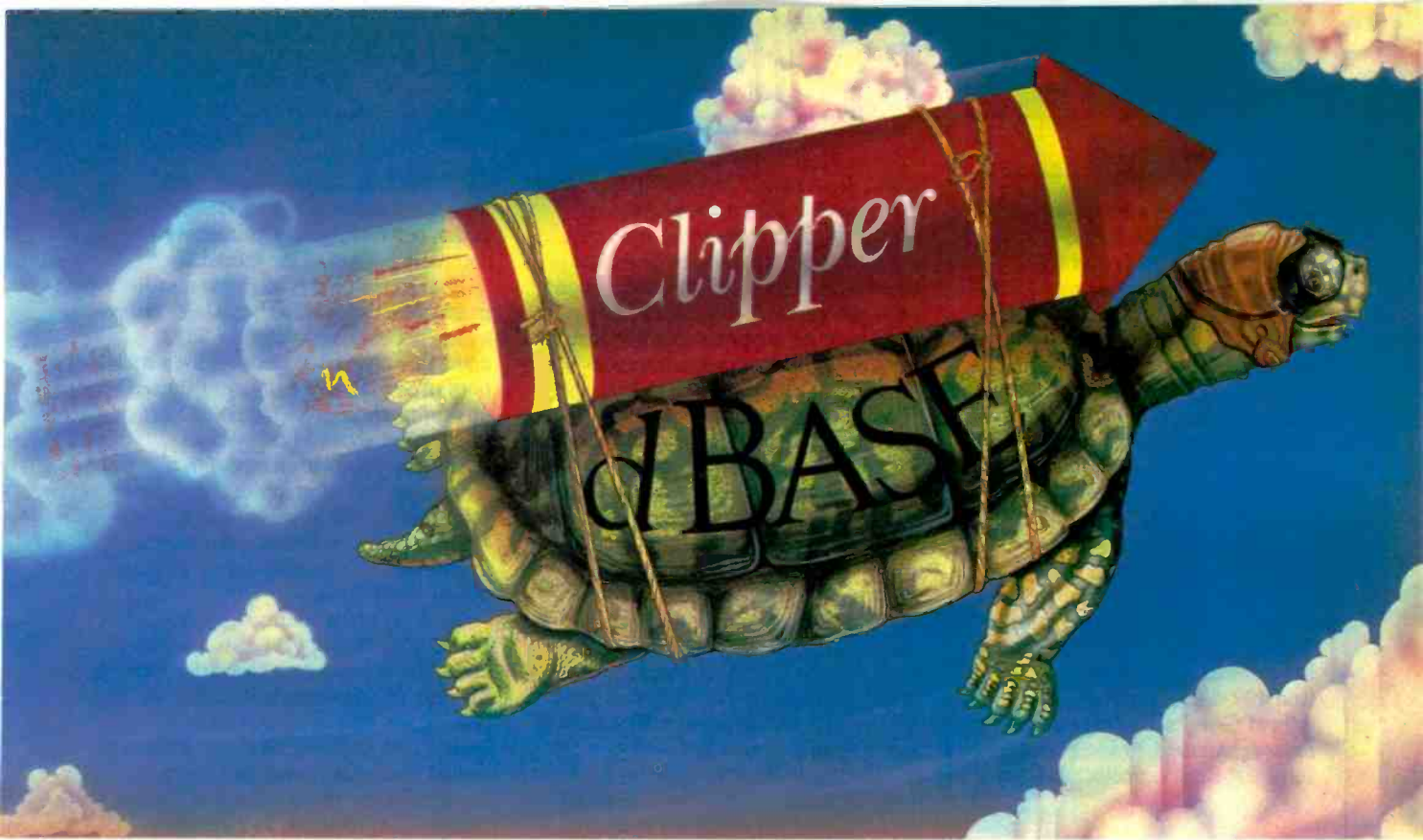

Real programmers don't use dBASE. Or do they?

We're finding that some very swift programmers are using it to write some very fast applications, and are completing their projects much more quickly. But they cheat.

They use our Clipper™ compiler to combine dBASE™ with C and assembler.

With dBASE used like pseudo-code, they can then quickly create prototypes that actually run.

Then, with dBASE doing the high-level database functions, they use our Clipper compiler to link in C or assembly language modules from their own bag of tricks.

And they're finding that they're linking in less than they expected because Clipper compiled code runs so fast and because of Clipper's built-in enhancements.

Clipper includes easy networking that provides file and record locking the way it should be done.

Fast screens that can be treated as memory variables and eliminate the need for direct screen writes and all that tortuous heap management code.

Box commands that make windowing a breeze. And more.

So if you'd like to use your time more productively, check us out: Nantucket Corporation, 12555 W. Jefferson Boulevard, Los Angeles, CA 90066.

Or if you're on deadline, call (213) 390-7923 today.

Clipper could get you out of the soup.



Turtle Souped

 Nantucket®

© Nantucket Corporation 1987. Clipper is a trademark of Nantucket Corporation; dBASE isn't. In Europe: Nantucket Corporation (Europe) 2 Bluecoats Avenue, Fore Street, Hertford, Herts SG14 1PB Telephone 0992 554621.

Inquiry 192 for End-Users. Inquiry 193 for DEALERS ONLY.

SEPTEMBER 1987 • B Y T E 39

GSS*X/386, it's a Xenix-based implementation for 80386-based machines. At press time, only an advance release was ready, but GSS said that the final edition will be ready by the end of the year and will support, among other things, EGA and VGA boards. . . . Only a game? **Strategic Simulations Inc.** reports that **George Bush** was elected president of the U.S. by a landslide in a simulation of the 1988 election. The company hosted a simulated election at the Consumer Electronics Show, using its newest game program, **President Elect—1988 Edition**. In the simulated contest, Bush won 499 electoral votes. Loser **Albert Gore**, senator from Tennessee, garnered 39 votes. And some say Bush is unelectable.

York, New York). The board uses eight 8-MHz NEC V20 microprocessors (each with 32K bytes of no-wait-state RAM) in a proprietary arrangement to produce eight 1-million-instructions-per-second processing nodes. The configuration supports multiple instruction; multiple data program execution, with a ninth V20 controlling inter-processor communications; PC interface; and data-acquisition functions via on-board programmable I/O ports. You can install up to eight boards (64 processors) in a single system.

Parallon will not run most existing PC software, but it can run parallel programs in the background while standard PC programs operate normally in the foreground. The Parallon Developer's kit lists for \$1250 and includes a loader and monitor/debugger. A parallel C compiler is in the works, according to Human Devices.

Martingale Research (Allen, TX) has a hierarchical dynamic system called SYSPRO (which stands for system simulation program). Written in FORTRAN, SYSPRO lists for \$995 and includes object code, code for data-file generation, a plotting program, utilities, a user's manual, and an hour of phone consultation. With it, you can develop networks of up to 100 neurons.

SYSPRO Plus, which costs \$1295, adds the source code for the back-propagation network, giving you nearly complete control of the model.

If you aren't ready to invest that much, Martingale also has a back-propagation network simulator for \$275 and a demonstration package for a rock-bottom \$75. In any event, you'll need an arithmetic coprocessor (8087 or 80287) and about 512K bytes of RAM (for 100-neuron models), along with some sort of graphics (EGA recommended). Graphics are not an absolute requirement, because the output is also available in ASCII for paper-and-pencil plotting.

Hecht-Nielsen Neurocomputer Corp. (San Diego, CA) sells a neurocomputer coprocessor board that fits into any PC AT-compatible slot. At \$9500, the ANZA board treads the boundaries of "low cost," but it lets you design and create simulations of neural nets for use in such areas as pattern recognition, robotics, and database searching. The company said the card can implement a network with up to 30,000 neurons and 480,000 interconnections. At the conference, Hecht-Nielsen demonstrated a face-recognition system based on the ANZA board.

Campus Nets, Sharing Research Seen as Keys to Academic Computing

Establishing effective campus networks, developing instructional programs that are more than computerized page-turners, and sharing the results of research are the biggest challenges facing academic computing, according to participants at a recent university conference. Representatives from more than 30 schools gathered in Boston, at a conference sponsored by IBM's Academic Information Systems (ACIS) division, to discuss the state of computing in colleges. They also exhibited projects that demonstrate the use of microcomputers (IBM microcomputers) as tools for learning.

Jerry Latta, IBM's ACIS group director and a former physics teacher, predicted that we'll soon see "a major cultural change" in education, a change that will be caused by campus-wide networks and computer-based instruction. Latta said instructional software

now being developed at "leading" universities is designed to enhance learning rather than to assume the teacher's role. He also said that if programs are to be effective learning tools, they have to be more than textbooks adapted to a computer screen. "This is not automated page-turning," Latta said.

IBM's ACIS program provides research funds and equipment to schools that Latta termed "leaders": Carnegie-Mellon, Cornell, MIT, University of Texas, UCLA, University of Florida, and others. Some participants at the conference, even though they benefit from endowments such as IBM's, expressed concern that only the better known universities get significant research funds, while other schools can barely stock their libraries.

Asked if there's a trend toward colleges that have and colleges that have not, Latta said the schools that get

grants will share the results of their research with schools that lack such funding. This "fan-out effect" will spread the technology to schools with "modest budgets," Latta said. He mentioned the University of Wisconsin's Wisc-Ware program, a network for distributing instructional software, as one way in which technology is disseminated.

Some of the PC-based projects on display at the conference included a program to help people who have to work with toxic chemicals; Philo the Logician, intended to help students in introductory logic classes; tools for building expert systems; programs aimed at improving learning in large science-lecture classes; LAN-based courseware for students to read and critique each other's writing; an interactive phonetics lab; and programs for simulating molecular dynamics.

TECHNOLOGY NEWS WANTED. *The news staff at BYTE is always interested in hearing about new technological and scientific developments that might have an impact on microcomputers and the people who use them. We also want to keep track of innovative uses of that technology. If you know of advances or projects that involve research relevant to microcomputing and want to share that information, please contact us. Call the Microbytes staff at (603) 924-9281, send mail on BIX to Microbytes, or write to us at One Phoenix Mill Lane, Peterborough, NH 03458.*

Now the best is twice as good.

How could anything be twice as good as the Norton Utilities™?

Good question.

After all, the Norton Utilities is far and away the best-selling program of its kind in the world.

Its remarkable UnErase™ feature has rescued the data—and the derrières—of thousands of grateful PC users.

While its passel of popular disk management programs is about the most useful thing to happen to PCs since MS/DOS.

So what could possibly be better than the Norton Utilities?

Better than ever.

Well, for starters there's the Norton Utilities Version 4.0.

It works all the same time-saving and data-saving wonders of our earlier versions—many of them three to five times faster than before.

It also performs several entirely new functions that are worth the price of the program all by themselves.

Like the unique *File Info* which lets you attach descriptions of up to 65 characters to your files.

(That is, if you can think of one that long.)

The new *Norton Integrator* lets you control every single Utility from a single program, and gives you on-line help for each function.

While the new user

interface makes the Utilities so quick and easy to run it's ridiculous.

Better yet.

All of which brings us to the new Advanced Edition of the Utilities.

Because the Advanced Edition contains all of the features, functions and enhancements of Version 4.0.

Along with a wish list of technical features and functions sufficient to satisfy the yearnings of all those customers who've been politely writing and calling to request them.

Like *Speed Disk*, for tightening up disk space and optimizing access.

And *Format Recover*, for unformatting your accidentally reformatted hard disk.

If you're so inclined, you can explore absolute disk sectors, edit file directories, even attack the FAT table.

And, for the first time, get the upper hand on your hard disk's partition table.

Which of the new Norton Utilities is best for you is up to you, of course.

But one thing's for sure. Either way, you'll get the best of Peter Norton.

Peter Norton
COMPUTING

THE NORTON UTILITIES

DATA RECOVERY
DISK MANAGEMENT

For the complete IBM® PC family and compatibles.

4.0

■ "Don't compute without it." —New York Times. ■ "Highly recommended for business users." —Time-Life Access Newsletter. ■ "Indispensable." —PC Magazine. ■ "Essential in day-to-day personal computing." —Personal Computing Magazine. ■ Three years voted "World Class" Best Utilities. —PC World. ■ "A pleasure to use." —PC Week. ■ "You'll bless this disk." —Peter McWilliams/
The Personal Computer Book.



A life saver for your data.

THE NORTON UTILITIES



A life saver for your data.

ADVANCED EDITION

DATA RECOVERY
DISK MANAGEMENT

For the complete IBM® PC family and compatibles.

■ All the features of the "indispensable" Norton Utilities—the world's best-selling disk management package. ■ Loaded with significant new technical enhancements. ■ Includes a powerful new version of the remarkable UnErase™ data recovery feature. ■ A must for everyone who demands the most from their PCs.

Designed for the IBM® PC, PC-AT and DOS compatibles. Available at most software dealers, or direct from Peter Norton Computing, Inc., 2210 Wilshire Blvd. #186, Santa Monica, CA 90403. 213-453-2361. Visa and Mastercard welcome. ©1987 Peter Norton Computing.

THIS TIME WE OUTSMARTED

115,200
Baud Rate

Hayes Smartcom III

SCOPE™
Advanced
Scripting
Language

Peruse
Buffer

~~~~~
~~~~~

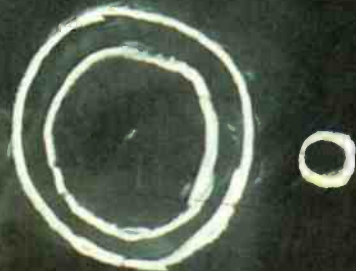

EVEN OURSELVES.

Full-Featured
Editor

File
Compression

New Transfer
Protocols

We at Hayes have always been credited with being ahead of our time. Now, we're even ahead of ourselves. Introducing Smartcom III,[™] clearly the most advanced, full-featured communications program ever designed for the IBM[®] PC-XT, AT, PS/2 family and your Hayes modem.

Smartcom III includes on-line help facilities for the novice as well as more advanced features for the power user. Features like a peruse buffer to automatically store information for later disk capture, printing or editing, an editor for creating and revising text, both on-line and off-line, and the support for multiple communications sessions with two remote systems simultaneously. Smartcom III also offers on-line DOS operations for the performance of common disk and subdirectory operations without ever having to exit the Hayes program. It even provides file compression and scrambling techniques for the enhancement of effective throughput and private data transmission.

Plus, with Smartcom III's Simple Communications Programming Environment, SCOPE,[™] the transmission process can be totally automated. This easy-to-use scripting language comes complete with a learn mode and provides access to the programming tools used to create Smartcom III itself.

So now that you know what Smartcom III is capable of, you may wonder where intelligence of this caliber will lead you. And the answer to that is the future.

If you currently use Smartcom II[®] or Crosstalk[®], take advantage of our special introductory offer:

If you purchased Smartcom II prior to 1/1/87, return the original program disk to us along with \$60 and we'll upgrade you to Smartcom III; if you purchased Smartcom II after 1/1/87, return it along with \$30 and dated proof of purchase for a Smartcom III upgrade. And if you use Crosstalk, send any version of the original program disk along with \$60 and we'll give you the same Smartcom III upgrade.

This offer good through 12/31/87 only in the USA and Canada.

For more information, contact your local Hayes Dealer, write Hayes at the address below, or call 404-441-1617.



Hayes[®]

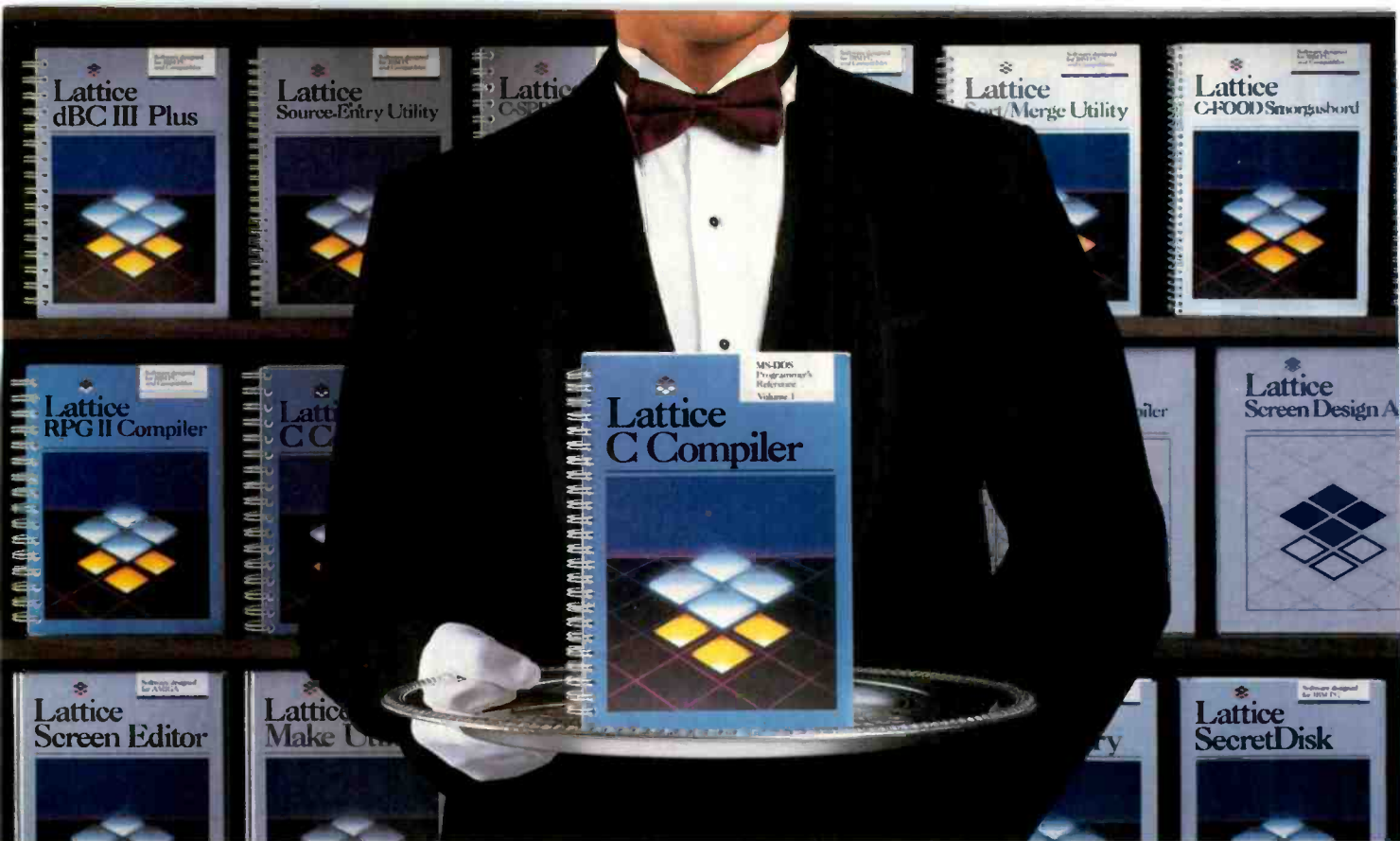

Our software comes with something no one else can offer.

When you join the Lattice family of customers, you'll discover that your software purchase is backed by more than just an excellent warranty. It's backed by unparalleled technical support. By a total commitment to your success and satisfaction. And by Lattice's dedication to excellence in products and services.

Unlike other software manufacturers who charge you for services after you've purchased their product, Lattice offers a unique package of support programs at a price we can all live with—FREE.

Lattice Bulletin Board Service
LBBS is our 24-hour a day bulletin board system that allows you to obtain notification of new releases, general information on Lattice products, and programs for the serious user. And if you've ever experienced the frustration of having to wait a year or more for a new release (that has corrected a bug), you'll really appreciate LBBS. Because with this service, you can actually download the latest program fixes to instantly eliminate any bugs discovered after release.

Available through dealers and distributors worldwide.

Lattice Service.

Technical Support Hotline

Responsible, dependable and capable Support Representatives are only a phone call away. You will talk to a highly skilled expert who is trained to answer any questions you have relating to specific Lattice products. Remember, your complete satisfaction is our goal.

McGraw-Hill BIX™ Network

The Byte Information Exchange (BIX) Network is a dial-in conference system that connects you with a Special Interest Group of Lattice users. The nominal one-time registration fee allows you to BIX-mail your questions—via your modem—directly to Lattice. Or you can post your questions in the conference mode for Lattice or other users to answer. Once again, you have 24-hour access.

You Also Receive:

- Timely updates and exciting enhancements
- 30-day, money-back guarantee
- Lattice Works Newsletter
- Technical Bulletins
- Access to Lattice User Groups

Lattice has developed more than 50 different Microcomputer software tools that are used by programmers worldwide. We were there for every MS-DOS release. We're there now for OS/2. And we'll be there for the next generation of technical changes. But most of all, Lattice is there for you.



Lattice

Subsidiary of SAS Institute Inc.

Lattice, Incorporated
2500 S. Highland Avenue
Lombard, IL 60148
Phone: 800/533-3577
In Illinois: 312/916-1600

Inquiry 150

Two Programs Bundled with 1-megabyte Macs

Apple Computer recently showed us MultiFinder and HyperCard, two very impressive new software packages for 1-megabyte Macintoshes.

MultiFinder allows you to keep multiple applications ready for use and gives you limited multitasking, with almost perfect compatibility with existing Mac applications.

HyperCard uses the metaphor of "a stack of cards" (actually, a file full of graphic/text images) to provide a usable way of storing and cross-referencing data; it is also the foundation for what Apple calls *stackware*, user- and commercially produced applications that sit on top of HyperCard.

One of the most significant things about these two products is that they will soon be included with the purchase of any 1-megabyte or larger machine or motherboard upgrade, thus making both of them part of the standard Macintosh configuration. (Officials at Apple said that existing Mac users will be able to buy these products for under \$50 each.)

MultiFinder is a new file that augments the existing Finder by allowing you to display multiple applications and switch between them by clicking in the appropriate window. Unlike Apple's Switcher program, MultiFinder shows each application's window on the same desktop.

We played with an alpha version of MultiFinder and found that at least 90 percent of the applications we tried behaved well with it. MultiFinder usually took between 2 and 5 seconds to switch applications and refresh the display.

MultiFinder also offers limited multitasking capability with applications designed for it. New code in the Mac's Event Manager steals control from an active application (when it is doing nothing) and passes it to inactive applications that can do some small part of their work and return it in under 100 milliseconds. The Event Manager can steal control from *any* Mac application, even existing ones, but new applications can be written to surrender control with less overhead.

MultiFinder will include a built-in background task that spools print jobs, thus freeing the Mac for other work (this feature was not available in the version we saw).

Apple personnel reported that numerous companies are working on both enhanced and new products that can use background time (including background terminal programs). They also said that

future versions of MultiFinder will build toward full multitasking, but they had no details on this.

By most people's definition of the word, HyperCard is a new category of software. Though it has roots in previous Mac and non-Mac applications, HyperCard is as much a new *approach* to dealing with data as it is a product for doing so. Another way of looking at it is as the next and newest level of the Macintosh user interface. In fact, Apple personnel (who say that the company is getting out of the software business) were promoting HyperCard as a platform on which programmers can build commercial products—though they were quick to point out that HyperCard is also useful right out of the box.

HyperCard stores information (text, graphics, sound, animation, and—indirectly—anything else you can think of) in a stack file full of screen-size images called *cards*. Any card can point to any other card, even a card in another file on a shared file server. These links can already be present in a stack, or you can put them in yourself. With just a few simple mouse-based movements, you can "paste" into a card a dialog button that, when pressed, will take you to any card that you designate.

This brings us to another important aspect of HyperCard: the multiple levels at which it can be used. You can set HyperCard to run at a given level, which sim-

plifies the menu bar accordingly.

At the first two levels, *browsing* and *typing*, you can look at stacks and modify and add cards. Many people will not get past these levels and will use supplied stack examples that function like phone lists, address books, appointment books, and similar applications.

The remaining three levels, *painting*, *authoring*, and *programming*, will attract some users into deeper and more fundamental levels of modifying a stack or creating a new one. At these levels, you can do things like change the size of a field, add a predefined button, and even specify exactly what a button does when you press it. HyperCard uses a simple but powerful English-like script language called HyperTalk to define a button's behavior.

Software developers can interact with HyperCard in a sixth way. By writing the appropriate programs, compiling them, and hiding them inside a stack file, a programmer can add new commands to HyperTalk, thus extending HyperCard to do things it was not explicitly designed to do. One example we saw was a cross-referenced geographic atlas; when we clicked on certain points on the screen, a laser-disk player that was connected to the Mac instantly displayed a satellite photograph of the area clicked on.

We have played with a beta version of HyperCard for several days and, so far, have found it fast, *very* useful, and a lot of fun. Look for a more detailed report on MultiFinder in the November BYTE and a report on HyperCard in the December issue.

—Gregg Williams and
Tom Thompson

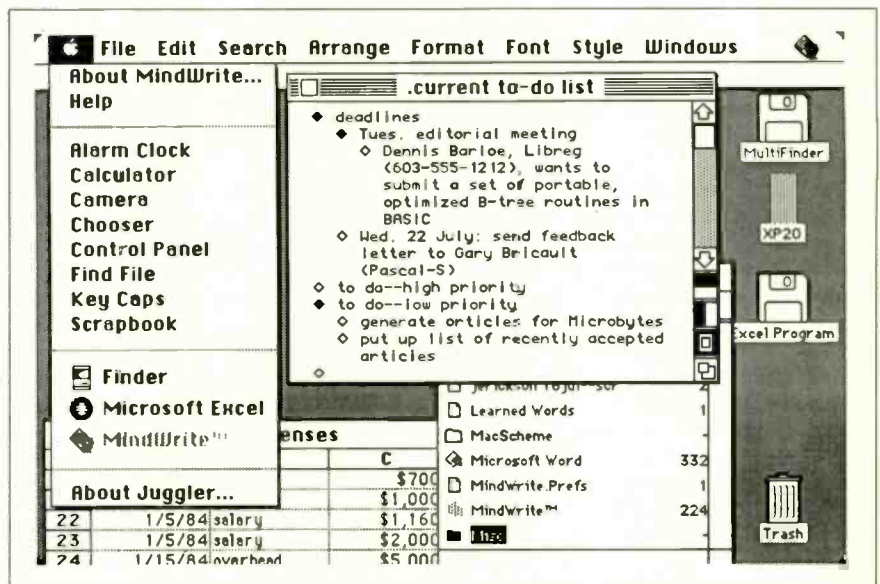

Figure 1: Apple's new MultiFinder.

PaintJet Prints in Color

Hewlett-Packard's PaintJet color graphics printer uses thermal ink-jet technology to produce text and graphics with a resolution of 180 by 180 dots per inch. It also prints near-letter-quality text at 167 characters per second.

The printer mechanism holds four inks (black, yellow, magenta, and cyan) and mixes them to produce red, blue, and green. With the appropriate software, you can mix the three primary colors to produce 330 different shades and hues.

The PaintJet uses 60 nozzles to transfer the ink to the media. The nozzles, black or colored inks, and electrical printing elements come in disposable cartridges. HP rates the cartridge life at 1.1 million characters—about 1100 pages of text or 180 pages of color graphics.

You can use cut-sheet paper or single-sheet transparency film in the PaintJet in sizes up to 8½ by 11 inches. A full page of color graphics on paper takes approximately 4 minutes to print. A special mode, used for producing color transparencies, requires about 8 minutes.

The PaintJet measures 3.9 by 14.4 by 11.9 inches and weighs 11 pounds. Its noise level during printing is below 50 decibels. The printer is available with either serial, parallel, or HP-IB (IEEE-488) interfaces.

Price: \$1395; black cartridge, \$27.95; color cartridge, \$34.95.

Contact: Hewlett Packard, 3000 Hanover St., Palo Alto, CA 94304, (415) 857-1501.
Inquiry 576.

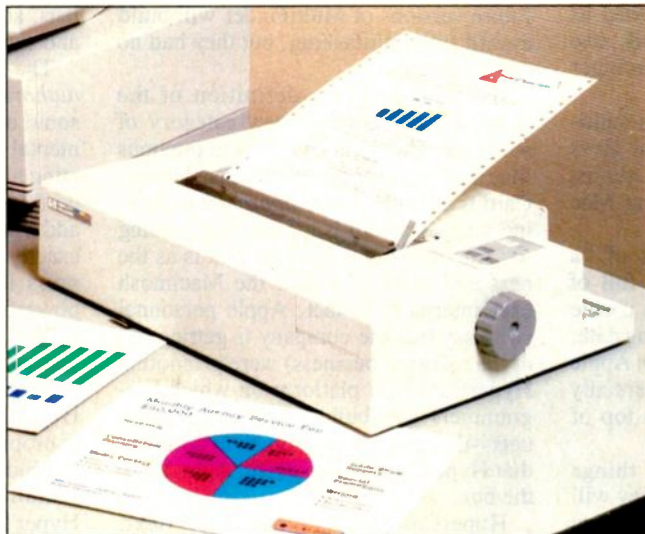

HP's PaintJet produces up to 330 shades and hues.

Protected-Mode 286 and 386 Operating Systems

Extend MS-DOS with the OS/286 or OS/386 protected-mode operating systems. The systems run on top of DOS, using the same interface, so your DOS 3.x calls and BIOS functions are accessible. Device drivers and TSR (terminate-and-stay-resident programs) interrupt handlers written for DOS also run under OS/286 and /386.

OS/386 offers a 4-giga-byte address space and adds 32-bit performance to 386 systems, and you can customize it to give unmodified DOS programs up to 900K bytes, no matter how many TSRs, networks, or disk caches are installed. You can convert your 8086 assembly language programs to 16-bit

(286) mode. On the 386, a 16-bit program runs two to three times faster than it would on the 286, the company reports. If you convert the program to 32 bits, it increases the speed another two to four times. Using the developer's toolkit, you can recompile programs written in C, Pascal, FORTRAN, or Common LISP.

The operating systems come with a kernel, linker, and symbolic debugger/command processor. Options include 16- and 32-bit compilers, High C, Professional Pascal, F77L FORTRAN, and a 32-bit assembler. The symbolic debugger acts as a command processor with command-line editing, a history mechanism, dynamic environment variables, and nesting of batch files.

Applications you develop with the 386 operating system

are portable to other IBM PC-based 386 systems. Applications developed with OS/286 can be ported to compatible 286 and 386 systems.

To run the operating systems, you load them as device drivers at boot time. OS/386 uses two physical processors when they are present and requires an A.I. Architects HummingBoard, a Compaq 386, or a Chips and Technologies 386 Chipset or compatible with at least 1 megabyte of extended memory. For OS/286, you need an IBM PC AT or compatible with at least 1 megabyte of extended memory.

Price: \$495 each.

Contact: A.I. Architects Inc., One Kendall Square, Suite 2200, Cambridge, MA 02139, (617) 577-8052.
Inquiry 577.

Unix Operating System

System V/386, a Unix operating system for the Intel 80386 microprocessor, includes optional development, word processing, and Streams networking packages. Source code is available.

The operating system runs on any 386 machine, according to Microport.

Price: Two-user system, \$199; development module, \$499; text processing, \$199; run-time system with all modules, \$799; source code, \$25,000. At press time, Microport had not set a price for the networking package.
Contact: Microport Systems Inc., 10 Victor Square, Scotts Valley, CA 95066, (800) 722-8649; in CA, (800) 822-8649.

Inquiry 578.

continued

SEND US YOUR NEW PRODUCT RELEASE

If you want us to consider your product for publication, send us full information about it, including its price, ship date, and an address and telephone number where readers can get further information. Send to New Products Editor, BYTE, One Phoenix Mill Lane, Peterborough, NH 03458. Information contained in these items is based on manufacturers' written statements and/or telephone interviews with BYTE reporters. BYTE does not represent itself as having formally reviewed each product mentioned.

THE RIGHT ANSWER TO THE BACKUP QUESTION



NOW IT'S EASY, FAST, AND AUTOMATIC

The software in Genoa's Galaxy™ tape system makes backup easy and fast. Just choose your options from the menu, press a few keys, and four minutes later your 20 MB hard disk is all backed up.

SMART, AUTOMATIC

You can set your Genoa Galaxy to backup automatically on a regular basis—like once a day. (That's smart!) If you're working on your computer when it's time to backup, the Galaxy will remind you it's time to take a five-minute break. Or, you can tell Galaxy to backup automatically after hours.

And, while the Galaxy backs up your data, it will display an on-screen status report.

NETWORK UPGRADEABLE

Add Genoa's GenWare™ software to your Galaxy tape backup system,

Inquiry 109

and you can backup the data in your Novell network quickly and automatically. You can also easily exchange data between your stand-alone Galaxy units and your network units.

Genoa has the answer to the backup question: a whole family of tape backup units, from 20 to 120 MB, that are easy, automatic, and fast.

For the dealer nearest you or for more information, call 408-432-9090. Or write Genoa Systems Corporation, 73 E. Trimble Road, San Jose, CA 95131. FAX: 408-434-0997, TELEX: 172319

See us at PC EXPO
Booth 1721



Genoa

We make PCs better.



*5 MB a minute!
Genoa's menu-
driven software
makes it easy!*

© 1987 Genoa Systems Corporation.
GenWare and Galaxy are trademarks of Genoa Systems Corporation.



Snap Shot digitizes images for manipulation under Windows.

Snap Shot Does Windows

BioScan's Snap Shot lets you capture and digitize moving or static images from television cameras, VCRs, or laser disks (any RS-170 signal). The program supports real-time digitization to 256 gray levels at a resolution of 512 by 512 pixels. You can control the brightness and contrast of the video signal.

Before printing the image, you can crop, size, enhance, halftone, and preview your image under Microsoft Windows. The program directly supports Aldus PageMaker, or you can transfer bit-mapped images to any application through the Windows Clipboard or create TIFF files for high-resolution hard copy.

Three models of Snap Shot are available. The Model 10 includes software, a full-slot image-processing board, cables, and connectors. The Model 20 adds a 13-inch RGB monitor, and the Model 30 includes all of the above plus a monochrome video camera, a macro-zoom lens, cables, and a stand.

Snap Shot runs on IBM PC XTs, ATs, and compatibles with MS-DOS or PC-DOS 2.0 or higher, 512K bytes of RAM (640K bytes recommended), a Microsoft Mouse, and Microsoft Windows. Two floppy disk drives are re-

quired, and a hard disk drive is recommended. Price: Model 10, \$2250; Model 20, \$2860; Model 30, \$3570.

Contact: BioScan Inc., 4520 Union Bay Place NE, Seattle, WA 98105, (206) 523-5000. Inquiry 579.

Transfer Data Between Incompatible Programs

Magic Mirror is a memory-resident program that lets you reformat and transfer data between incompatible programs.

You highlight data on your screen to store it on disk in a memory buffer limited only by your disk space. You can then call the data from the disk and format it for the program you want to send it to. You can store the formatting procedure in a library and reformat the data to be transferred to another program. After you reformat the data, you call up the target program and transfer the data. The data is sent as if it is coming directly from the keyboard, SoftLogic Solutions reports. The entire process takes only a few seconds.

Magic Mirror runs on IBM PCs and compatibles with MS-DOS or PC-DOS 2.0

or higher and 256K bytes of RAM. It occupies 48K bytes.

Price: \$89.95.

Contact: SoftLogic Solutions Inc., One Perimeter Rd., Manchester, NH 03103, (800) 272-9900; in New Hampshire, (603) 627-9900. Inquiry 580.

Use Existing Drives with your PS/2

Short for "external disk adapter," EDAPT from Flagstaff Engineering is an external disk drive interface package that lets you connect your existing 3 1/2-, 5 1/4-, or 8-inch floppy disk drive to the IBM PS/2 computers.

EDAPT consists of a 2-by 2-inch connector that installs into the PS/2's second disk drive cavity, and a flat cable that runs from the card out to an existing drive. The package also includes a set of software device drivers and a power cable that uses the PS/2's 5- and 12-volt power supply.

The interface adapter delivers data at rates of 250 or 500 bits per second. The company claims it can be installed in less than 5 minutes.

Price: \$99. Contact: Flagstaff Engineering, 1120 Kaibab Lane, Flagstaff, AZ 86001, (602) 779-3341.

Inquiry 581.

Altos Combines 386 and Xenix V

Altos Computer Systems claims its 386 Series 2000 is the industry's first 80386-based system that runs the Xenix System V operating system. The Series 2000 is available in four configurations, all of which include an 80386 operating at 16 MHz, an 80387 coprocessor, and a 32K-byte instruction cache. Also standard is a 1.2-megabyte 5 1/4-inch floppy disk drive, a 60-megabyte streaming tape-backup unit,

and an Altos V terminal.

The Model 2408S supports up to 20 users and includes 4 megabytes of RAM and a 65-megabyte ESDI (enhanced small device interface) hard disk drive. The 2417S has a 142-megabyte hard disk drive. Supporting up to 64 users, the Model 2417M includes 4 megabytes of RAM, a 142-megabyte hard disk drive, and the Multidrop cabling and transmission system that lets you connect up to 64 RS-232C devices to the system on a single cable. At the top of the line, the Model 2817M adds 4 more megabytes.

Any of the Series 2000 systems can be expanded to up to 16 megabytes of RAM in 2-, 4-, and 8-megabyte increments. A 320-megabyte hard disk drive and an uninterruptible power supply (UPS) for the system will be available by the end of the year. The UPS will fit as a pedestal base to the computer system and will come with software that provides power-fail/auto-restart services if the power failure lasts longer than the UPS's 3- to 5-minute rated life.

Price: \$25,000 and up. Contact: Altos Computer Systems, 2641 Orchard Parkway, San Jose, CA 95134, (408) 946-6700. Inquiry 582.

continued

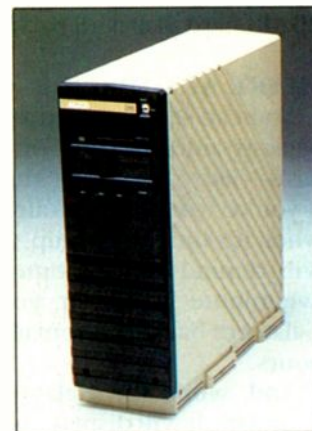

The Altos Series 2000 runs Xenix and the 80386.

Long life and high speed run in our family.



Introducing the LaserImage 3000™ from PCPI. It gives you 15 page per minute speed, 20,000 pages per month capability and the industry's longest life cycle.

The LaserImage 3000 — the most productive laser printer available.

No other laser printer in its class can surpass the 3000's speed. But there is more to productivity than high speed. There's reliability. The LaserImage 3000 is built to last. You can expect a 1,500,000 page life cycle from its advanced engine. Nationwide on-site service is also available.

Choose the PCPI laser printer that's right for you.

Whether you need the 6 page per minute speed and economy of the LaserImage 1000™, the 8 page speed of the LaserImage 2000™ or the high speed of the LaserImage 3000™, you are selecting a printer designed to give you dependability and long life. As

with any close family, the LaserImage Series™ printers are fully compatible.

All members of the LaserImage family have a plotter and a graphics printer "built in."

The LaserImage family emulates LaserJet Plus, Diablo 630, IBM Proprinter, HP plotters and the Epson FX/80 — all standard. If your software works with these, it will work with any of the LaserImage Series printers.



Advanced graphic capabilities.

The LaserImage Series utilizes 100% of the page for graphics with sharp 300 dots per inch resolution. You can print in either the portrait or landscape format with PCPI's full bit map fonts and graphics.

Create the perfect image.

Choose your typeface from 31 standard near-typeset quality fonts, or select other optional typefaces from the PCPI font library.

Call PCPI toll free for the dealer nearest you.

 **Personal Computer Products, Inc.**

11590 West Bernardo Court
San Diego, CA 92127
(619) 485-8411; Telex: 499-2939
FAX: (619) 487-5809

Toll Free Information:
1-800-225-4098
In California:
1-800-262-0522

PCPI is a public company whose shares are traded on the NASDAQ exchange.

© 1987 Personal Computer Products, Inc. LaserImage, LaserImage Series, LaserImage 1000, 2000 and 3000 are trademarks of Personal Computer Products, Inc. IBM Proprinter is a registered trademark of International Business Machines Corporation. Epson FX/80 is a registered trademark of Epson America, Inc. HP and LaserJet Plus are registered trademarks of Hewlett-Packard Company. Diablo 630 is a registered trademark of Xerox Corporation.

Three-Dimensional Charting and Graphing

Windows Graph is a business graphics and charting program that is compatible with Microsoft Windows. From data files, you can create two- and three-dimensional charts and graphs of up to 34 by 34 inches, including area, bar, column, line pie, scatter, table, and combination charts. You can also place an unlimited number of charts on one page. A Folder is included, in which you can store custom graphs for later access.

The program features three-dimensional support for all chart types, and Microsoft's DDE (Dynamic Data Exchange) protocol is supported for linking data from one application to another. You can also link data to charts within Windows Graph to the data contained in a worksheet window and import data from a variety of spreadsheets. You can also create labels in the worksheet window and type and manipulate text interactively on the chart pages. Line and paragraph formatting and editing features enable you to place text in the graph area. When you modify the data in the worksheet, the program automatically updates the charts.

In creating three-dimensional views, you control the amount of depth and projection view. You can also change the location of the axes, add major and minor grids, and clarify legends.

In addition, Windows Graph is compatible with In*a*Vision and Windows Draw, and you can load charts into either program for further manipulation.

Windows Graph runs on IBM PCs and compatibles with at least 320K bytes of RAM, two floppy disk drives, a graphics card, a graphics monitor, and a printer. Micro-

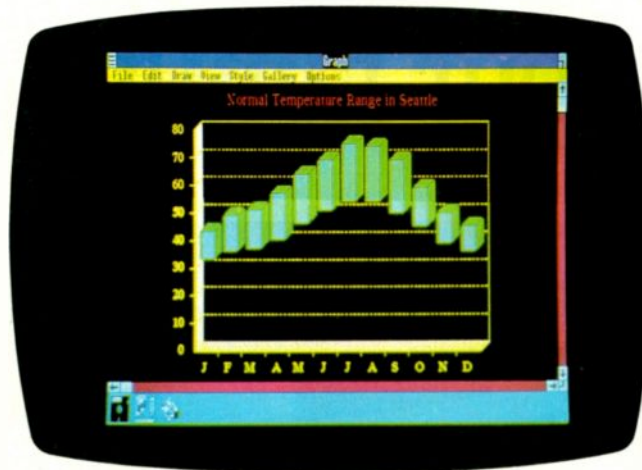

A three-dimensional bar chart created with Windows Graph.

grafx recommends a hard disk drive and 512K bytes of RAM.

Price: \$395.

Contact: Micrografx Inc., 1820 North Greenville Ave., Richardson, TX 75081, (214) 234-1769.

Inquiry 583.

Getting Personal with Laser Printers

General Computer's Personal LaserPrinter (PLP) takes up about as much desktop real estate as an Imagewriter and costs about half the price of an Apple LaserWriter. The PLP runs with the Macintosh Plus, SE, and II. A 1-megabyte RAM cartridge plugged into the printer lets you run it off the 512K-byte Macintosh.

Having only 4K bytes of ROM and a tiny RAM buffer, the PLP is essentially a "dumb" printer. It uses Macintosh QuickDraw routines to process the image and then writes print files into spool files on your disk.

Using a Ricoh 6000 print engine, the PLP prints at 6 pages per minute. It features three print modes: high-quality mode prints at resolutions of 300 dots per inch; draft mode prints at 72 dpi and provides a printout in seconds; and preview mode prints to screen, letting you see

what the document will look like when printed.

The PLP comes with 13 LaserWriter fonts plus nine additional fonts. The fonts are defined in software as outlines, enabling you to scale, rotate, and manipulate the fonts without affecting output quality. The PLP does not support PostScript and can't be used on a local-area network.

General Computer claims the PLP's cartridge is good for 1500 copies, the drum cartridge is good for 20,000 copies, and the cleaner cartridge for 10,000 copies. A replacement drum cartridge with two cleaner cartridges are available for about \$200.

Price: \$2599; toner cartridge, \$29.

Contact: General Computer Corp., 215 First St., Cambridge, MA 02142, (617) 492-5500.

Inquiry 584.

28-millisecond Drive for the Mac SE and II

The Rodime 450 RX is an internal 45-megabyte hard disk drive that's designed for the Macintosh SE and II. The company claims the drive has an average access time of 28 milliseconds.

An embedded SCSI controller is used in the drive because of space constraints. Rodime says it fully meets Apple's SCSI specifications. The controller handles all error correction and disk management. Built-in diagnostics identify and flag 28 different fault conditions in the drive, controller, or power supply. The 450 RX is fully arbitrating, which maximizes data throughput when you use multiple SCSI peripherals. You can connect up to seven additional SCSI peripherals through the drive's SCSI port.

The 450 RX includes FileGuard software for backing up data from the hard disk to floppies. You must have a dealer install the drive in the Macintosh II or SE. Its installation is identical to that of Apple's hard disk drives, requiring a supplied mounting bracket and a 50-pin connector.

Price: \$1595.

Contact: Rodime Inc., Peripheral Systems Division, 29525 Chagrin Blvd., Suite 214, Pepper Pike, OH 44122, (216) 765-8414.

Inquiry 585.

Z80 Card Adds CP/M to PCs

MicroSolution's high-speed Z80 card lets you run CP/M programs on your IBM PC or compatible. The card requires a half-size 8-bit slot and has 64K bytes of RAM and an 8-bit Z80 processor that runs at 8 MHz with no wait states.

The Z80 card comes with the high-speed version of the company's UniDOS, a CP/M emulator that lets you create a complete Z80 CP/M version 2.2-compatible environment on your system.

Price: \$195.

Contact: MicroSolutions Computer Products, 132 West Lincoln Highway, DeKalb, IL 60115, (815) 756-3411.

Inquiry 586.

continued

FLIGHT!

From the sophisticated realism, detail, and intellectual stimulation of Flight Simulator...



...to the brute-force fun, thrills and excitement of Jet...



...with new adventures in Scenery Disks...



...SubLOGIC. The State of the Art in Flight.

See Your Dealer. For additional product ordering information or the name of the dealer nearest you, call (800) 637-4983.



subLOGIC
Corporation
713 Edgebrook Drive
Champaign IL 61820
(217) 359-8482 Telex: 206995
ORDER LINE: (800) 637-4983
(except in Illinois, Alaska and Hawaii)
Open 7 AM to 9 PM Central Time

DG Upgrades Laptop

The Model 2T is Data General's latest incarnation of its Data General/One laptop computer. Weighing just under 12 pounds, the 2T adds a supertwist backlit LCD screen, a dual-speed Intel 80C88 running at both 4.77 MHz and 7.16 MHz, and removable batteries.

The standard model of the 2T has 512K bytes of RAM and a single 3½-inch floppy disk drive. You can upgrade the system's internal RAM in 256K-byte, 1-megabyte, or 2-megabyte increments, up to a maximum of 2.5 megabytes. A 3½-inch 10-megabyte internal hard disk drive is optional.

You can manually switch the supertwist LCD screen to a normal (nonbacklit) screen to conserve battery life. The system's nickel-cadmium rechargeable batteries are now removable and can power the 2T for up to 5 hours. In addition to the internal trickle-charger for the battery, an optional quick charge is also available. It fully recharges the batteries in 2 hours.

The 2T has both parallel and serial ports. Other available options include a Hayes-compatible 1200-bps modem, an interface card for an external 5¼-inch floppy disk drive, an 8087 coprocessor, a carrying case, and a car adapter. For software, the Model 2T comes with MS-DOS 3.2.

Price: \$1695; with a hard disk drive, \$2895.

Contact: Data General Corp., 4400 Computer Dr., Westborough, MA 01580, (800) 328-2436; in Massachusetts, (617) 366-8911.
Inquiry 587.

Split-Personality System

Data General's Colorscan/2 is a diskless workstation with a motherboard full of application-spe-

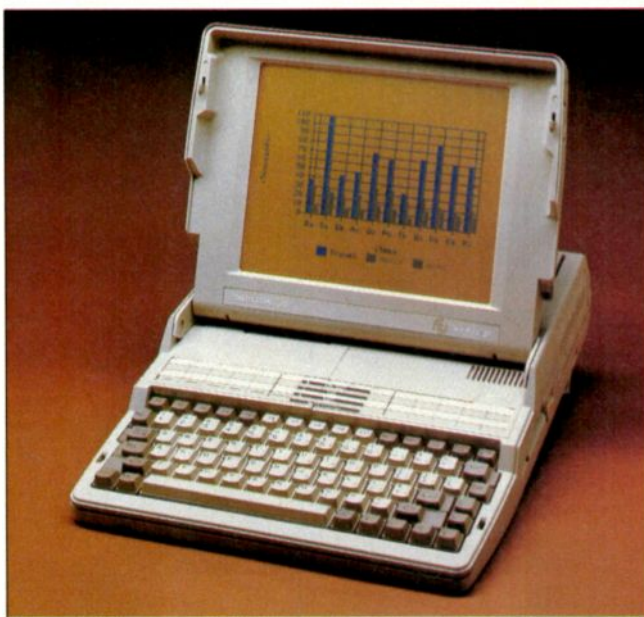

DG's upgraded Model 2T adds a supertwist backlit LCD.

cific integrated circuits (ASICs), a V30 processor running at 8 MHz, and 768K bytes of zero-wait-state RAM. The system unit has a footprint of 15 by 10 inches and is just 2½ inches high. Not surprisingly, surface-mount technology is used extensively, and the Datamedia folks have taken several hints from IBM PS/2 designers with quick-disconnect components. The only cable goes to a cooling fan.

The Colorscan/2 can be a DEC VT-240-compatible terminal and a PC at the same time. You can hook up to an on-line system, such as a VAX, while working with a PC application at the same time. You switch between the terminal session and the PC by hitting a hot key. Since the Colorscan/2 has two RS-232C serial ports, you can also have an on-line session running under MS-DOS at the same time. As with the Macintosh, there's a Clipboard that lets you move data back and forth between VT-240 and PC modes.

The system's EGA chips are designed by Datamedia and provide a resolution of up to 800 by 480 on the 13-inch monitor, which is included. Characters display in a 10-by-10 pixel matrix. A custom ASIC also saves EGA registers and memory while in VT-240 mode. All VT-240 functions are stored in a 128K-byte ROM.

There's room inside for two add-in boards, as long as they aren't longer than 8 inches. You install all boards horizontally using 8-bit bus 90-degree adapters that are included with the unit.

Options include a long, narrow, battery-backed 2-megabyte RAM card that doesn't use either of the two expansion slots. And for those who choose not to go diskless, there's an expansion unit that sits vertically like a book and contains both a 3½-inch 1.4-megabyte floppy drive and a 3½-inch 20-megabyte hard disk drive. There's also a cardfile interface that accepts credit-card-size memory cards.

Price: \$2000; 2-megabyte RAM card, \$750; 3½-inch floppy/hard disk unit,

\$995; cardfile interface, \$150.
Contact: Datamedia Corp., 11 Trafalgar Square, Nashua, NH 03063, (603) 886-1570.
Inquiry 588.

ON! System is Always On

The aptly-named ON! System doesn't have a power switch. In a departure from contemporary computer designs, the system stores all its built-in programs in RAM, with configurations available in either 2 or 4 megabytes.

Running an 8-bit Z80 processor with the ZRDOS operating system, the ON! System has built-in power-conditioning and backup power that the company claims will hold all data for up to 14 hours.

The built-in menu-driven software includes the New-Word word processor with a 65,000-word spelling checker and over 50 special utilities for file and system management. The system has an external 5¼-inch floppy disk drive that reads and writes data from over 40 disk formats, including MS-DOS.

The system unit has no moving parts, and, according to the company, doesn't require a cooling fan. Single parallel and RS-232C serial ports are standard, and the standard 14-inch monochrome display is available in green, amber, or white phosphor.

Price: \$2895 with 2-megabytes of RAM; \$3595 with 4 megabytes.

Contact: ON! Systems Inc., 27944 North Bradley Rd., Libertyville, IL 60048, (312) 680-4680.
Inquiry 589.

continued



Verbatim 6.6 MB subsystems: high capacity with the convenience and security of removable floppies.

You'll appreciate the advantages of Verbatim 6.6 MB subsystems from Kodak.

You get 5.57 MB of formatted capacity and all the benefits of removable floppies. Store unlimited amounts of data. Easily transport files. Secure important information. And back up your hard disk quickly and reliably.

No need to throw away existing disks. This subsystem can read disks with 48, 96, and 192 tpi. Available to fit inside or alongside your IBM PS/2 model 30 or IBM PC/XT/AT and compatibles. Everything you need for fast, easy installation comes with the package. And you're protected by a one-year warranty.

Ask your computer dealer about this new Verbatim subsystem and media. Or call 1-800-44KODAK, ext. 990.

Free Back-It software for hard-disk backup with purchase, while supplies last.

6.6 MB OF ADDED STORAGE FROM KODAK

The new vision of Kodak



PERIPHERALS

Low-Cost Buffer Gets Smaller

The new version of the MicroStuffer printer buffer measures approximately 5 by 6 inches—about half the size of its predecessor. The buffer has 64K bytes of RAM and works with all computers and most parallel-port printers. Installation is a simple matter of plugging it between your computer and printer.

MicroStuffer is totally transparent to the applications software. It shows buffer status with a flashing light on the front panel, which flashes faster as you fill the buffer. A "clear" push button clears the RAM, while a Repeat button lets you make multiple copies.

Price: \$69.95.

Contact: Supra Corp., 1133 Commercial Way, Albany, OR 97321, (503) 967-9075.

Inquiry 590.

Up to a Gigabyte on the Mac II

Mirror Technologies' ProStation 1024 is a combination hard disk drive/tape-backup system designed especially for the Macintosh II, although it has a standard SCSI interface for use with any system so equipped. The system is available in hard disk configurations of 85, 172, 340, 680, and 1024 megabytes. The tape-backup part of the system is available in 40-, 120-, and 240-megabyte sizes. You can upgrade both the hard disk drive and tape-backup system to higher capacities.

The ProStation 1024 measures 6 by 17 by 18 inches and weighs about 45 pounds. Its surface color and texture match that of the Macintosh II, and it's designed to sit under the monitor. Mirror Technologies says a fully configured gigabyte system has an average track-to-track time of 17 millisecond-

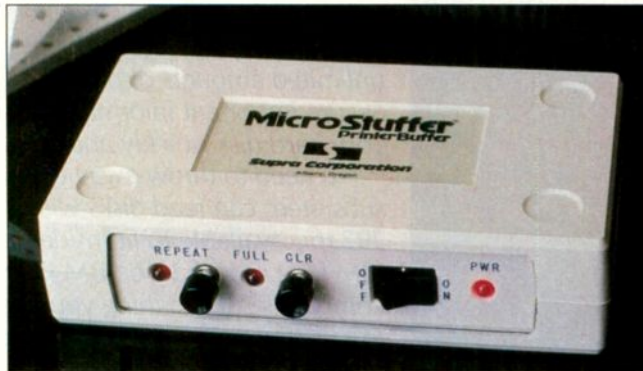

The new MicroStuffer printer buffer is compact and low-cost.

onds. The tape-backup system writes approximately 3.5 megabytes per minute on standard data cartridges. The unit has a locking on/off switch.

Software shipped with the ProStation includes Manager's SafetyNet, a program that performs a backup especially for file servers on the AppleShare network. Also included is Personal SafetyNet, which lets you back up your own files; AutoBack, a time-delay backup option; an Imagewriter spooler; and Think Technologies' Laser-Speed.

Price: \$7995 and up.

Contact: Mirror Technologies Inc., 2209 Phelps Rd., Hugo, MN 55038, (612) 426-3276.

Inquiry 591.

New QMS Printer Supports PostScript

The QMS-PS 800 II is a new PostScript-based laser printer that prints 8 pages per minute using the Canon CXD print engine. The unit handles 500 sheets of input and 400 sheets of output and has a duty cycle of 10,000 copies per month. You can specify face-up or face-down paper output and use the dual-input bin for first sheet/ second sheet applications.

The 800 II has a megabyte of RAM for full-page graphics and text applications. Besides the PostScript

page-description language, the printer also emulates the HP LaserJet Plus, HPGL (Hewlett-Packard graphics language), and Diablo printers. RS-232C, RS-422, and parallel interfaces are standard.

Price: \$6495.

Contact: QMS Inc., P.O. Box 81250, Mobile, AL 36689, (205) 633-4300.

Inquiry 592.

Saba's Full-Page Reader

Saba Technologies' Page Reader is a full-page document reader that reads a page a minute into your computer while operating in the background. According to the company, the unit preserves the format of a scanned document, reading it into a wide variety of word-processing programs while keeping the same indentations, tabs, spaces, and columns as the original document.

The reader will also transfer columns of words and numbers into Lotus 1-2-3 and will read graphics into two graphics programs: PC Paint and PC Paintbrush. The reader has a built-in sheet feeder that lets it read stacks of up to five typewritten pages. Although Page Reader's software requires only 270K bytes of RAM, Saba recommends 640K bytes and a hard disk drive. To use the reader, you access the software with a hot key, tell it

which word processor you're using, and press a key to activate the reader.

Price: \$1299.

Contact: Saba Technologies Inc., 9300 Southwest Gemini Dr., Beaverton, OR 97005, (503) 626-7050.

Inquiry 593.

Bypassing the Power Supply

CPS (continuous parallel-power system) from Applied Research and Technology is an alternative power source for personal computers. The Co-Pilot 140 CPS supplies DC power directly to a computer by bypassing the computer's internal power supply and completely eliminating any switchover delays. According to the manufacturer, the battery system and the Co-Pilot will power a fully loaded AT-type computer for approximately 2 hours.

Under normal operating conditions, the computer power supply receives AC power from the 115-volt AC line and converts the AC to appropriate levels of DC. Simultaneously, the Co-Pilot is producing the same voltages, which are placed in parallel to the computer's. Should a power loss occur, the computer's power supply would begin to fail, and its DC levels would start to drop. But because the battery-backed Co-Pilot's DC levels are connected to the computer, the system's power needs are met.

The company says its parallel-power approach also eliminates the normal AC/DC/AC conversion inefficiencies associated with other backup and uninterruptible power supplies.

Price: \$1495.

Contact: Applied Research and Technology Inc., 6400 Powers Ferry Rd., Suite 110, Atlanta, GA 30339, (404) 951-9919.

Inquiry 594.

continued

proteus™

There are plenty of compatibles but none can match PROTEUS in IBM Compatibility, Speed, Reliability, Support & Delivery.

PROTEUS SYSTEMS features:

16MHz, Zero Wait State, 32-bit RAM Keyboard, Software, & Hardware selectable CPU speed & Wait States ROM based advanced Diagnostics. Norton SI: 23.5 !!

Editor's Choice.

"There are so many nice aspects to Proteus and the company that makes it, there isn't enough room to cover them all."

*Lawrence Oakley,
Business Computer Digest, 3/87*

**PROTEUS SYSTEMS ARE DESIGNED AND BUILT IN USA
15-MONTH FULL WARRANTY, LABOR & PARTS INCLUDED
FREE NATIONWIDE ON YOUR SITE SERVICE!
24 HOUR ONLINE CUSTOMER SUPPORT**

100% COMPATIBILITY WITH DOS, UNIX, XENIX, AUTOCAD, NOVELL



**30 DAY
MONEYBACK
GUARANTEE**

CHOOSE FROM THESE BEST HIGH SPEED 386 AND 286 SYSTEMS

PROTEUS-386

- 80386 Intel CPU 16 MHz. Norton SI: 23.5
- Zero Wait State, 64KB Cache
- Keyboard Selectable Speed and Wait state
- 1 Megabyte 32-bit RAM expandable to 4MB on system board
- 2 Serials, 1 Parallel Port
- ROM Based Diagnostics & Setup
- Onboard EGA Bios
- Coprocessor Support
- Hard Disk & Floppy Controller
- Clock, Cal., & battery backup
- 230W quality 110/220v power supply
- 1.2MB Floppy Drive, Choice of
- 3.5" Microfloppy
- Enhanced Keyboard
- 14" High Resolution Monitor
- Herc. compatible Mono graphics card
- 40Mb Fast Hard Disk installed

Price: \$4195.00

40MB EGA System \$4595.00

PROTEUS-386i

- 80386-16 Intel CPU, 16 MHz.
- 512KB 32-bit RAM expandable to 16MB on Two 32-bit Slots
- Keyboard Selectable Speeds
- Coprocessor Socket
- Serial, & Parallels on mainbd.
- 230W, quality Power supply 110/220v
- Hard Disk & Floppy Controller
- 1.2MB Floppy Drive, choice of
- 3.5" microfloppy
- High Resolution Monochrome Monitor
- Herc. Compatible Mono adapter
- Enhanced Keyboard
- 40MB Fast Hard Disk Installed
- Custom Configurations available

Price: \$3595.00

40MB EGA System \$3995.00

PROTEUS-286E

- Intel 80286, 6/8 MHz opt. 10MHz.
- 1024K RAM on System board
- 8 I/O slots
- Coprocessor Socket
- Clock, Cal., Battery backup
- 195W 110/220v power supply
- Hard Disk & Floppy comb. controller
- 2 Serials, Parallel Ports
- 1.2MB Floppy Drive (reads both
- 1.2MB and 360K floppy)
- Maxiswitch AT Style Keyboard
- Herc. Compat. Graphics Adapter
- High Resolution Monochrome Monitor
- 20MB Seagate Hard Disk Installed

Price: \$1780.00

"...Proteus 286e is a clear winner.

We recommend it!"

InfoWorld, April 27, 87

PROTEUS-286F

- 10MHz ZERO Wait State System
- 80286-10, 8/10MHz Keybd Select.
- 512K RAM expandable to 1MB
- 2 Serials & 1 Parallel Ports
- 8 I/O Slots
- Hard Disk & Floppy Controller
- Clock, Cal. & Battery
- 195W Power supply 110/220v
- 1.2MB Floppy Drive, reads 1.2MB and 360K floppy.
- Maxiswitch Keyboard

Price: \$1450.00

WE HAVE THE LARGEST SELECTION OF HARD DISKS, MONITORS, AND ADAPTERS AT THE LOWEST PRICES. WE CUSTOM CONFIGURE AND TEST THE SYSTEMS EXTENSIVELY FOR YOU.

HARD DISKS

20MB Seagate	\$279
30MB Seagate	\$575
30MB Rodime	\$565
40MB Seagate	\$649
42MB Miniscribe	\$665
44MB Priam	\$795
80MB Seagate	\$985
140 Maxtor	\$c all
190 Maxtor	\$c all

ADD-ONS

Herc. Compatible Mono card.	\$98
IBM Compatible Color card	\$98
Proteus EGA, CGA, MDA card	\$255
Vega Delux EGA card	\$345
ATI Wonder Card	\$c a l
80287-8 Coprocessor	\$249
80287-10 Coprocessor	\$369
80387 Coprocessor	\$c a l
1200B Omnitel Modem	\$109
2400B Omnitel Modem	\$239
40MB Tape Backup int	\$469
60MB & 120MB Tape Bckup	\$c a l
3.5" 720K Floppy Dr.	\$175
360K Floppy Drive	\$109

MONITORS

High Resolution Monochrome	\$109
14" Proteus Mono Monitor	\$159
13" Color Monitor	\$340
14" Proteus EGA Monitor	\$449
NEC Multisync EGA Monitor	\$569

Terms: Visa/MC, COD, Prepayment with cash discount, University and Corporate POs accepted upon approval. Quantity discounts.

IBM is a trademark of International Business Machines Corp., all prices, terms subject to change

Inquiry 236

proteus™
The Intelligent Conclusion



To order or for information call us 1-800-782-8387

In New Jersey Call (201) 288 6525

Telex 510 601 096C

**Proteus Technology Corp,
377 Route 17,
Airport 17 Center,
Hasbrouck Heights, NJ 07604**

**Visit us at PC Expo
New York Booth #166C**

We wanted this to be a fair comparison.

TurboC

One look at what the competition left out of their C compiler and you'll see why there's only one choice for people who want to learn C. Introducing Microsoft® QuickC™, the C compiler that gives you the features you need to learn C quickly with no sacrifice of compilation or execution speed.

Only QuickC gives you a completely integrated debugging environment so you can detect program logic errors and correct them instantly. And you know this debugger is advanced because it's from the makers of the Microsoft CodeView® source-level debugger.

Only QuickC's graphics libraries let you take advantage of the PC's extensive graphics capabilities. Just like you've come to expect with other languages.

Only QuickC has special context sensitive help for the C language and library routines. And help is right where you need it. On screen, so you don't have to go looking for it.

Only QuickC gives you such highly acclaimed documentation. There are extensive examples to guide you. And there's a special tutorial that helps BASIC and Pascal users move over to C faster.

If you're thinking you might want to move to an even more powerful C later, QuickC's your only choice.

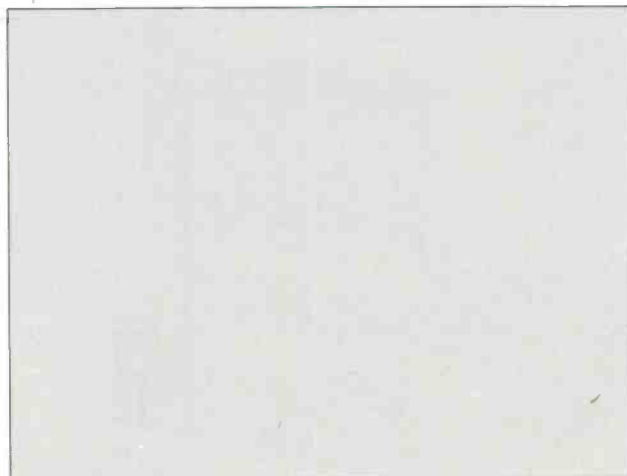

No integrated source-level debugging.

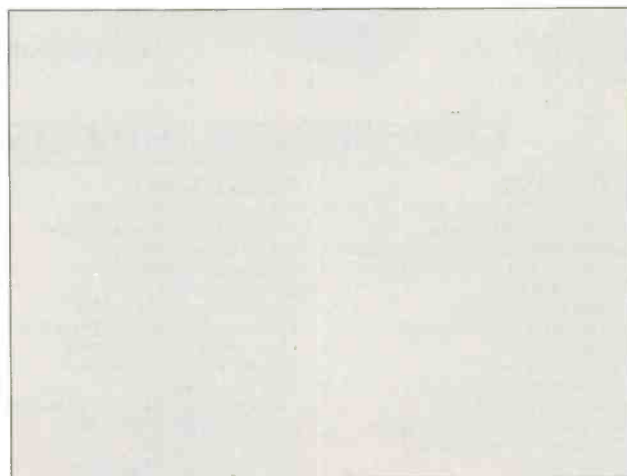

No graphics library.

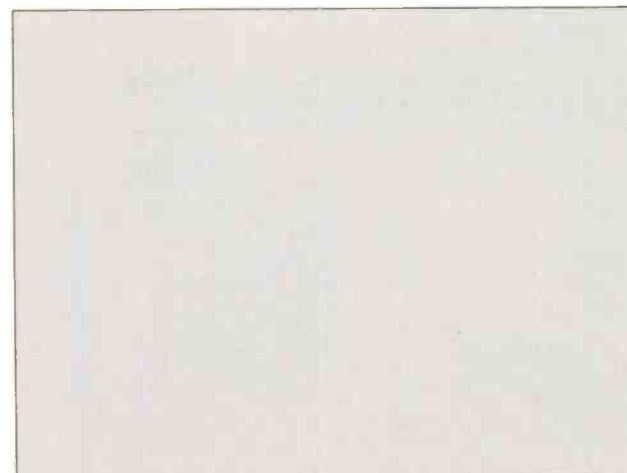

No on-line help for the C language or library routines.

Microsoft and CodeView are registered trademarks and QuickC is a trademark of Microsoft Corporation. Turbo C is a registered trademark of Borland International, Inc.

Life is not fair.

QuickC

Because no one else is truly 100% compatible with Microsoft C 5.0, the professional level optimizing compiler.

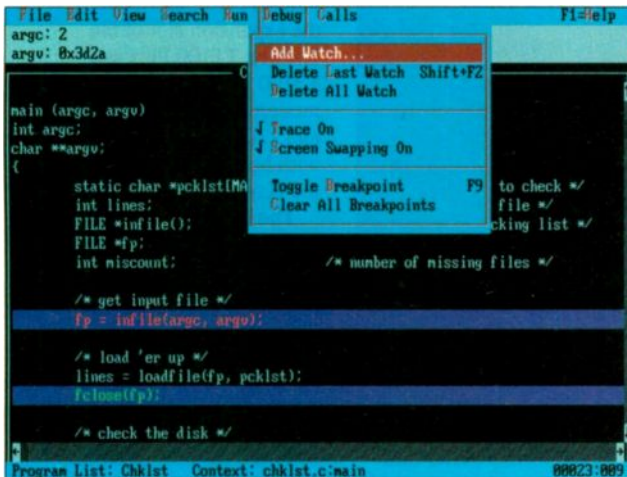

Seamlessly integrated source-level debugging.

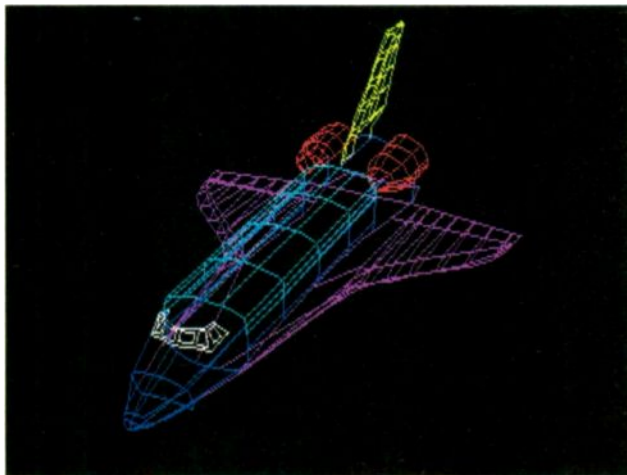

The full graphics library puts your program in another dimension. BitBlit, draw circles and arcs, fill regions and much more.

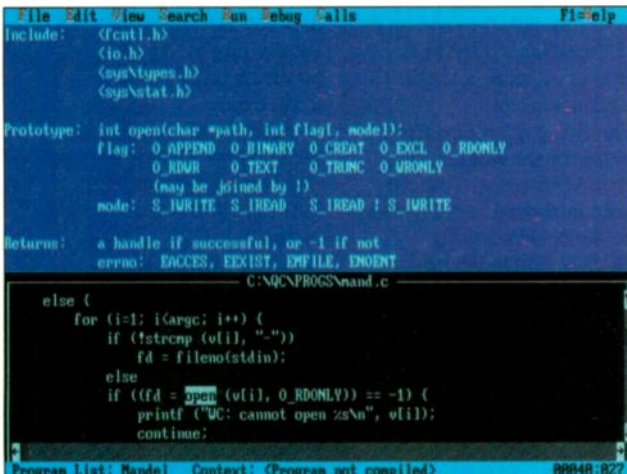

Instantly accessible on-line help only a keystroke away.

WordStar is a registered trademark of MicroPro International.

Microsoft QuickC Compiler Feature Comparison

	Microsoft QuickC Version 1.0	Turbo C® Version 1.0
Debugger		
Integrated debugger and editor	Yes	—
Source-level debugging	Yes	—
Watch local & global variables	Yes	—
Set breakpoints	Yes	—
Stack tracing	Yes	—
Editor and Environment		
WordStar® compatible	Yes	Yes
Context-sensitive help for C language	Yes	—
Context-sensitive help for C functions	Yes	—
Brace, bracket & parenthesis matching	Yes	—
Mouse support	Yes	—
Support for EGA 43-line mode	Yes	—
Documentation		
Complete C language reference	Yes	—
Examples for every library routine	Yes	—
Compiler		
Completely Microsoft CodeView compatible	Yes	—
Automatic enregistering	Yes	Yes
Integrated MAKE		
Automatically generates .MAK file	Yes	—
In-memory MAKE compatible with stand-alone MAKE	Yes	—
Include file dependencies	Yes	Yes
Libraries		
Graphics library included	Yes	—
CGA & EGA and VGA support	Yes	—
Library source code available	Yes (\$150)	Yes (\$150)
Microsoft C Optimizing		
Compiler 5.0 compatible	Yes	—
Microsoft LINK vs. Turbo Link		
Links programs up to 640K	Yes	—
Supports overlays	Yes	—
Directory searching for library files	Yes	—

At \$99.00, no one can give you more for the price. And if you're not happy, remember we back QuickC Compiler with a 30 day money back guarantee.*

What could be fairer than that?

Microsoft® QuickC™

For a QuickC information kit or the name of your nearest Microsoft dealer, call (800) 426-9400. In Washington State and Alaska, (206) 882-8088. In Canada, call (416) 673-7638.

*Offer valid only in U.S.A.

ADD - INS

Turbo Pascal Controls Controller

The MT1000 is a single-board electronic controller designed for a wide range of control applications. According to Measurement Technology, it's the first controller to be programmed with Borland's Turbo Pascal, which has been enhanced on the MT1000 to include software interrupts that allow your program to respond in real time to external events.

Based on Hitachi's HD64180 CMOS processor, the MT1000 includes 64K bytes of battery-backed CMOS RAM, 128K bytes of user EPROM, 1K byte of EEPROM (electrically erasable), and a clock/calendar. Three RS-232C serial ports are included.

You can connect the MT1000 directly to a wide variety of sensors, as well as voltage and current input signals. It also has six frequency inputs that allow any frequency in the range of 50 hertz to 1 MHz to be automatically measured to .005 percent resolution within 20 milliseconds.

An optional floppy disk controller/256K-byte RAM card is available. The MT1000 requires a single 5-volt DC supply and typically consumes 5 watts of power. **Price:** \$1625.

Contact: Measurement Technology Inc., 1595 Central St., Stoughton, MA 02072-1694, (617) 344-6230. **Inquiry 595.**

12 MHz for your PC

Breakthru 286-12 from the Personal Computer Support Group replaces your PC, XT, or compatible 8088 processor with an 80286 processor running at 12 MHz. The Breakthru requires a half slot and has a multiconductor cable that plugs into the system's current processor slot.

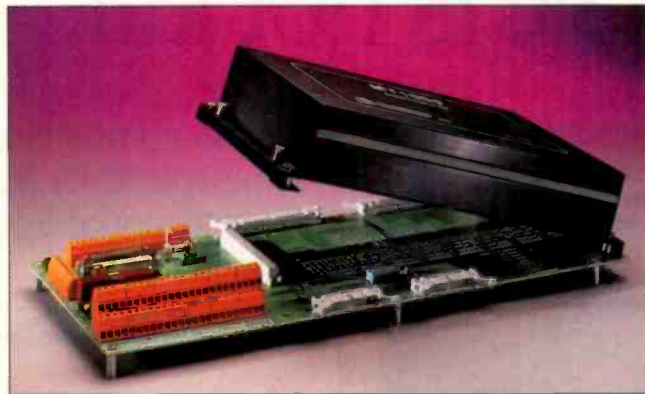

You can use Turbo Pascal to program the MT1000 controller.

The board has 16K bytes of cache memory and on-board logic for write buffering. The board can be slowed down via software control. Also included with the board is PCSCG's Lightning disk-cache software.

Price: \$595. **Contact:** Personal Computer Support Group, 11035 Harry Hines Blvd. #207, Dallas, TX 75229, (214) 351-0564. **Inquiry 596.**

Slotless Amiga Slot

The TimeSaver macro/clock for the Amiga 1000 plugs into the line between the computer and keyboard and attaches to the underside of your computer. The built-in replaceable lithium battery has a rated life of 12 to 18 months, and the unit automatically enters the date and time whenever you power-up or reboot your Amiga.

There's a built-in ROM with macros that contain shorthand versions of many CLI commands. It can be disabled if you desire. In addition, the TimeSaver has 7K bytes of RAM for programming macro keys, with a learn mode that remembers commands that you key in. You can also include any macro you

select in a start-up/reboot routine.

TimeSaver has a command-line history buffer that stores your last 1024 characters of CLI commands, and a command-line editor for editing CLI commands. The unit also allows you to password-protect your Amiga, preventing its start-up until you enter your personal password. **Price:** \$79.95.

Contact: C Ltd., 723 East Skinner, Wichita, KS 67211, (316) 267-3807. **Inquiry 597.**

Mighty Meg adds up to 14.5 Megabytes

Quadram's Mighty Meg is a memory-expansion board for IBM PC ATs and full compatibles that uses SIMMs (single in-line memory modules) to add up to 14.5 megabytes of RAM to your system, using a single 16-bit expansion slot.

The five available configurations for the Mighty Meg start at 512K bytes. You can expand the board incrementally up to 4 megabytes using 256K by 9 SIMM devices, or up to 14.5 megabytes using 1 megabyte by 9 SIMM devices.

Price: 512K bytes, \$545; 14.5 megabytes, \$4995. **Contact:** Quadram, One Quad Way, Norcross, GA 30093-2919, (404) 923-6666. **Inquiry 598.**

Two for the Toshiba

Multi-Tech Systems' MultiModem212TL is a plug-in card that fits into the expansion slot of the Toshiba T1100 Plus and T3100 laptop computers. The modem operates at both 300 and 1200 bps and is compatible with both the Bell 212A and the Hayes AT standards.

The MultiModem212TL measures 4.175 by 4.6 inches and interfaces with the internal Toshiba 60-pin bus. It includes two phone jacks and an on/off switch. The modem has a two-year warranty and is shipped with Multi-Tech's MultiComPC software on a 3½-inch disk. **Price:** \$299.

Contact: Multi-Tech Systems Inc., 82 Second Ave. SE, New Brighton, MN 55112, (800) 328-9717; in Minnesota, (612) 631-3550. **Inquiry 599.**

Megahertz Corp.'s EasyTalk EMS is a multifunction card for the Toshiba T1100 Plus that includes a modem and 1 megabyte of RAM.

EasyTalk's memory conforms to the Lotus/Microsoft/Intel Expanded Memory Specification. Since the memory uses about 10 percent of the power of a disk drive, Megahertz says using EasyTalk's memory as a RAM disk can extend the laptop's battery power. An ultra-low-power memory option is available.

The modem component of the board is Hayes-compatible and operates at both 300 and 1200 bps. Crosstalk communications software is included with the modem. **Price:** \$899.95; low-power memory option, \$200.

Contact: Megahertz Corp., 2681 Parleys Way, Suite 2-102, Salt Lake City, UT 84109, (801) 485-8857. **Inquiry 600.**

continued

SOFTWARE ENGINEERING COMES OF AGE.

ANNOUNCING LOGITECH MODULA-2 VERSION 3.0

Modula-2 is the language of choice for modern software engineering, and LOGITECH Modula-2 is the most powerful implementation available for the PC. The right language and the right tools have come together in one superior product. Whether you're working on a small program or a complex project, with LOGITECH Modula-2 Version 3.0 you can write more reliable, maintainable, better documented code in a fraction of the time at a fraction of the cost.

**FREE TURBO PASCAL
TO LOGITECH MODULA-2
TRANSLATOR**

NEW IMPROVED DEBUGGERS

Time gained with a fast compiler can be lost at debug time without the right debugging tools. With the powerful Logitech Modula-2 Debuggers you can debug your code *fast*, and dramatically improve your overall

project throughput. The Post Mortem Debugger analyzes the status of a program after it has terminated while the dynamic,

Run Time Debugger monitors the execution of a program with user defined break points. With their new, mouse based, multiple window user interface these powerful debugging tools are a pleasure to use.



NEW INTELLIGENT LINKER

Links only those routines from a particular module that you need, so you eliminate unreferenced routines and produce smaller, more compact executable files.

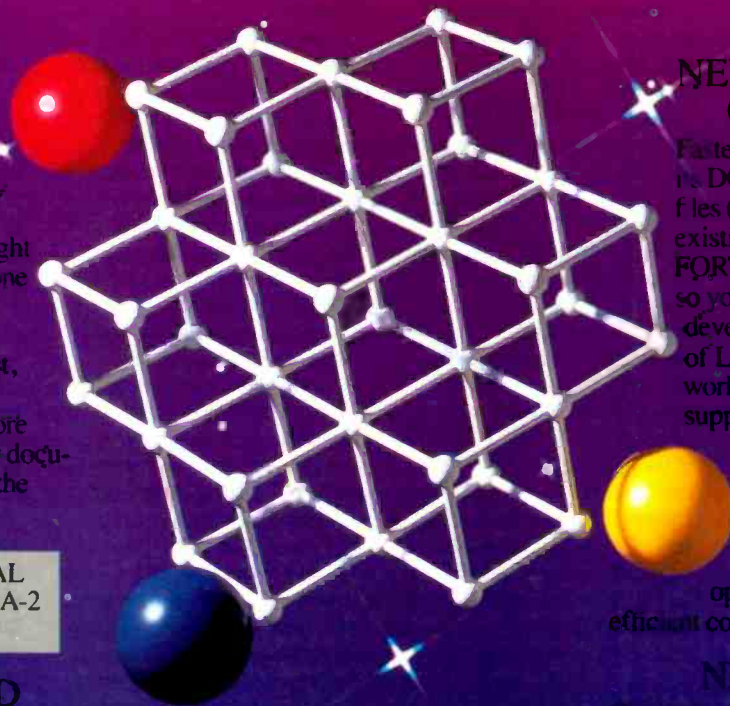

NEW, IMPROVED COMPILER

Faster and more flexible. Now the DOS linker compatible object files (.OBJ) can be linked with existing libraries in C, PASCAL, FORTRAN and ASSEMBLER—so you can build on previous development and put the power of LOGITECH Modula-2 to work for you, right now. Fully supports Wirth's latest language definition, including LONGINT and LONGSET, which provides large set support including SET of CHAR. Provides optimization for tighter, more efficient code generation.

NEW EDITOR

Our new, mouse based editor is fully integrated, easy to learn, fast and easy to use, and very customizable. Its multiple, overlapping windows and color support make it easy to manage parts of one file base several files on the screen at the time. You'll love using it—*with or without a mouse.*

Call for information about our VAX/VMS version. Site License, University Discounts, Dealer & Distributor pricing.

To place an order call toll-free

800-231-7717

In California:

800-552-8885

- LOGITECH Modula-2 V. 3.0 Compiler Pack** **\$99**
Compiler in overlay and fully linked form. Linkable Library, Post Mortem Debugger, Point Editor
- LOGITECH Modula-2 V. 3.0 Toolkit** **\$169**
Library sources, Linker, Run Time Debugger, MAKE, Decoder, Version, XRef, Formatter
- LOGITECH Modula-2 V. 3.0 Development System** **\$249**
Compiler Pack plus Toolkit
- Turbo Pascal to Modula-2 Translator** **FREE**
With Compiler Pack or Development System
- Window Package** **\$49**
Build true windowing into your Modula-2 code.
- Upgrade Package**
Call LOGITECH for information or to receive an order form.

Add \$6.50 for shipping and handling. California residents add applicable sales tax. Prices valid in U.S. only. Total Enclosed \$ _____

VISA MasterCard Check Enclosed

Card Number _____ Expiration Date _____

Signature _____

Name _____

Address _____

City _____

State _____

Zip _____

Phone _____

LOGITECH

LOGITECH, Inc.

6535 Kaiser Drive, Fremont, CA 94555

Telex 415-795-8500

In Europe: LOGITECH, Switzerland

TELE 21-21487-9656 Telex 458 217 Tech Ch

In the United Kingdom: LOGITECH, U.K.

TEL 24908-868071 FAX 44908-71751

Turbo Pascal is a registered trademark of Borland International. VAX and VMS are registered trademarks of Digital Equipment Corp.

Inquiry 158 for End-Users. Inquiry 159 for DEALERS ONLY.

SEPTEMBER 1987 • BYTE • 59

AI Development Environment Incorporates Virtual Memory

Written in 386 native mode with virtual memory supported at the hardware level, PowerLisp lets you develop and run 60-megabyte applications on 3-megabyte 386 systems or 31-megabyte applications on IBM PC ATs.

MicroProducts reports that PowerLisp is the full implementation of Interlisp, originally written for use on a PDP-10. Common LISP features are also included, and Interlisp and Common LISP programs can be supported simultaneously. Interlisp functions can call Common LISP functions, and vice versa.

You can communicate between PowerLisp code and DOS applications executing in DOS memory. The program also has features that correct typos, entry errors, and programming errors. A static program analyzer lets you find and edit every place that calls a given function or refers to specific variables, objects, or properties. Editing features let you put breakpoints in functions as well as trace them; debugging facilities are built-in; and a utility is included that retains session history, enabling you to redo or undo commands.

Power-Ex, an optional expert-system shell, is derived from EMYCIN and ported to PowerLisp. The shell supports backward-chaining reasoning, confidence factors, case files, automated consistency checking, and English-language consultations. An IBM PC running Power-Ex can support rule bases of thousands of rules and can directly import knowledge bases developed using EMYCIN.

You can configure PowerLisp to operate in extended memory above the 640K-byte limit. The pro-

gram comes in 286 and 386 versions, with the 286 version upgradable to a 386. MicroProducts reports that the 386 version is six times faster. To run the 286, you need an IBM PC or compatible with at least 2 megabytes of memory, a 30-megabyte hard disk drive, a CGA, EGA, or compatible graphics adapter, and MS-DOS or PC-DOS 3.0 or higher. To run the 386 version, you need a 386 system with at least 2 megabytes of memory, a 30-megabyte hard disk drive, a CGA, EGA, or compatible graphics adapter, and MS-DOS or PC-DOS 3.1 or higher.

Price: 286 version, \$1195 or \$1695 with 3-megabyte memory-expansion box; 386 version, \$1695; Power-Ex, \$500 (when purchased with the system).

Contact: MicroProducts Inc., 370 West Camino Gardens Blvd., Boca Raton, FL 33432, (800) 553-0777.

Inquiry 601.

TI Upgrades AI Development Tools

Texas Instruments has announced enhancements to its Personal Consultant Series of expert-system development tools. These include PC Scheme 3.0, Personal Consultant Easy 2.0, Personal Consultant Plus 3.0, two add-ons, and two run-time options.

PC Scheme 3.0 is an enhanced version of TI's implementation of Scheme, a lexically scoped dialect of LISP. Version 3.0 includes external language interfaces to C, Turbo Pascal, and others; random-file access and binary file I/O; and support for up to 2 megabytes of extended or expanded memory. An EMACS-like editor, EDWIN, lets you leave PC Scheme, execute a DOS-based program, and then return to PC Scheme. PC Scheme runs on IBM PCs, XT's, AT's, or

compatibles with at least 320K bytes of RAM, two floppy disk drives or one floppy and one hard disk drive, and PC-DOS or MS-DOS 2.0 or higher. It also requires a minimum of 520K bytes to run EDWIN.

Personal Consultant Easy 2.0 is a utility designed to simplify the development of expert systems with up to 300 rules. The program offers a rule-entry language, an integrated window-oriented editor, regression testing, and rule tracing. Version 2.0 includes enhanced interfaces to external data, an enhanced knowledge-base listing, and forward-chaining capability, which can be completely forward- or backward-chaining. With version 2.0, you can also write as well as read DOS files and interface to dBASE III, Lotus 1-2-3, and ASCII text files.

The program runs on IBM PC AT's and compatibles with 640K bytes of RAM, a 10-megabyte hard disk drive, and MS-DOS or PC-DOS 2.0 or higher.

Version 3.0 of Personal Consultant Plus, an expert-system shell, can, like Easy version 2.0, read data from external DOS or ASCII text files, Lotus 1-2-3, and dBASE III. Plus 3.0 also offers delivery options, which enable expert systems developed with either Personal Consultant Plus or Easy to be delivered in LISP or C on DOS-based computers. Knowledge bases developed with Easy are upwardly compatible with Plus, according to TI.

Plus 3.0 is designed to take advantage of 80286- or 386-based systems. It provides extended knowledge-representation features and increased rule capacity, enabling you to develop larger and more complex applications than you can with Easy. Also, like Easy, Plus 3.0 is enhanced with external language interfaces to C and Turbo Pascal and expanded forward-chaining and frame

control. Optional enhancements include the Images and PC Online programs.

Personal Consultant Plus 3.0 has the same hardware requirements as Easy 2.0.

Images and PC Online are optional add-on programs that run with Personal Consultant Plus. Images allows you to incorporate graphic images into your applications. It includes a set of interactive dials, gauges, and a selection of boxes to prompt you to input or display data. You can also use other graphics programs to create input forms, and you can display multiple images on the screen simultaneously.

PC Online supports data processing in batch mode. It lets you create process-monitoring systems that require little or no human interaction, TI reports. You can suppress screen output and notify the operator when information or action is required. PC Online also features reporting and trend-analysis capabilities.

Personal Consultant Plus runs on IBM PC AT's with at least 640K bytes of RAM and a 10-megabyte hard disk drive. You also need an EGA card to run Images.

One of the two run-time options for Personal Consultant Plus or Easy is C Delivery, available for DOS or Digital Equipment's VAX systems. C Delivery compiles the LISP-code knowledge bases into C source modules and links them with an inference engine and a window system, letting you deliver stand-alone or embedded applications on DOS-based systems.

Price: PC Scheme 3.0, \$95; Personal Consultant Easy 2.0, \$495; Personal Consultant Plus 3.0, \$2950; Images, \$495; PC Online, \$995; C Delivery, \$1995.

Contact: Texas Instruments Inc., Data Systems Group, P.O. Box 809063, DSG-150, Dallas, TX 75380-9063, (800) 527-3500.

Inquiry 602.

continued

Introducing Logitech's Publishing Solution

LOGITECH \$179
MOUSE
 with Publisher Software

Our Mouse and Publisher Software is the complete solution for people who want to produce great looking, attention getting documents without having to master a lot of complex commands and typographical jargon. It's easy to learn, fast to use, and it gets you the results you need right now.

Page Layout Made Easy
 You don't have to be a graphic designer to get professional quality results. Create and edit text right on the page. We offer design templates, automatic layout in 1-4 columns, automatic flow of text around graphics, and vertical and horizontal rulers to guide you.

Typography Made Easy
 Select from over 61 fonts representing 14 typefaces, in sizes suitable for headlines, subheads and text. We provide optimal line spacing automatically. You adjust for special effects.

Graphics Made Easy
 Use our ClipArt or create your own using LOGIPAIN, PC Paintbrush or MS Windows Paint software. You can shrink or expand your graphic images to fit. You can also modify, rotate or copy them.



To place a credit card order call our special toll-free number:
800-231-7717
 Call toll-free in California:
800-552-8885

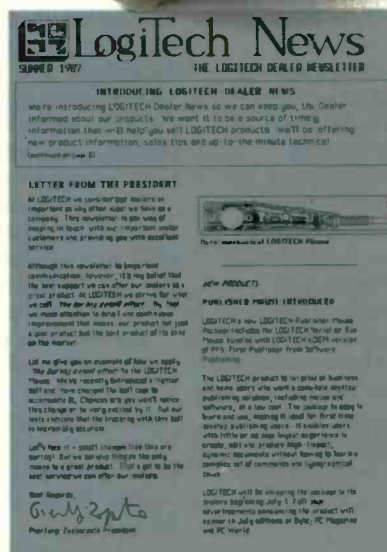

Produced on a dot matrix printer. Laser printer support also included.

30 Day Money-Back Guarantee
 3 Year Warranty

YES! I want to produce great looking documents now!
LOGITECH Publisher Package \$179
 w. Serial Mouse and Plus Software
 w. Bus Mouse and Plus Software
 Add \$6.50 for shipping and handling. California residents add applicable sales tax. Prices valid in U.S. only.

Total Enclosed \$ _____
 VISA MasterCard Check Enclosed

Card Number _____ Expiration Date _____

Signature _____

Name _____

Address _____

City _____ State _____

Zip _____ Phone _____

DEALER INQUIRIES WELCOME

LOGITECH

LOGITECH, Inc.
 805 Veterans Blvd., Redwood City, CA 94063
 Tel: 415-365-9852

In Europe:
 LOGITECH SA, Switzerland
 Tel: 41-21-879656 • Telex 458 217 Tech Ch
In Italy:
 Algot-Logitech Spa 39-2-215-5622

Engineering Model Analysis

Fujitsu's finite-element analysis program, Elm, enables you to test your three-dimensional structural designs for strength, safety, and performance. The program consists of an analysis module, ElmAnalysis, and integrated pre- and postprocessors, ElmPrelude and ElmEpilog.

ElmAnalysis performs static, eigenvalue, and response-spectrum analysis. The element library includes three-dimensional beam, truss, triangular, and quadrilateral shell elements, as well as two-dimensional 4-node and 8-node isoparametric elements.

The three dimensional finite-element analysis preprocessor, ElmPrelude, is menu-driven and replaces manual calculations and batch-mode data entry with a WYSIWYG (what-you-see-is-what-you-get) graphic approach to creating structural models. According to Fujitsu, you can display every feature of model composition through the use of colors and symbols (from element type, number, and rotation to boundary conditions). A Verify function enables you to display all the input data for a selected boundary condition or element.

The preprocessor includes pull-down menus, icons, and dialog boxes, and you use a mouse instead of the keyboard for data entry. Instead of looking up and keying in property values, you can use the industry-standard data supplied in the engineering libraries. If you want to perform your own batch-mode data entry rather than using ElmPrelude, you can use the free-format input scheme offered by ElmAnalysis.

ElmEpilog, the graphics

postprocessor, is also menu-driven and lets you review and manipulate the output of ElmAnalysis with visual displays and printouts of the structure's undeformed shape, deformed shape, and mode shapes.

Elm is written in C and is also available in a two-dimensional version. Elm runs on IBM PCs, XTs, ATs, and compatibles with a 360K-byte floppy disk drive, at least 512K bytes of RAM, MS-DOS or PC-DOS 2.0 or higher, a 10-megabyte hard disk drive, and a numeric coprocessor. To use the pre- and postprocessors, you need a mouse, an EGA graphics board, and a monitor. **Price:** \$3990; two-dimensional Elm, \$495.

Contact: Fujitsu America Inc., Engineering Products Dept., Information Systems Division, 3055 Orchard Dr., San Jose, CA 95134-2017, (408) 432-1300. **Inquiry 603.**

Threaded Interpretive Language for Laboratories

SALT II, a threaded-interpretive language developed at the University of Chicago, has about 200 assembly language instructions that you can call and compile within a BASIC program.

SALT II includes graphics routines for plotting records, scrolling plots or records, and placing cursors on plots. It enables you to analyze records for regional maximum and minimum, average, slope, threshold detection, integration, differentiation, and filtering. Other routines include expanded memory, transfer of numeric files to and from disk, laboratory interfacing, signal averaging, and

background operations from BASIC. You can also add your own assembly language routines to the language.

The program supports every function of Tecmar's Labmaster interface board, including A/D, D/A, digital I/O, and timer/counter functions.

SALT II requires an IBM PC, XT, AT, or compatible with at least 256K bytes of RAM and MS-DOS or PC-DOS 2.0 or higher. You must also have a Tecmar Labmaster board for laboratory interfacing and a CGA for graphics.

Price: \$75. **Contact:** Sam Fenster, 5801 South Dorchester, Suite 12A, Chicago, IL 60637, (312) 702-1491. **Inquiry 604.**

Drawing Chemical Structures on the Macintosh

DrawStructures contains 67 organic and biochemical structures, including all major classes of compounds and ring systems in object-oriented format for the Macintosh. Contained in PICT-format documents, you can use the structures as they appear, or modify them using MacDraw, MacDraft, or SuperPaint. Also included is a set of building blocks that can assist you in modifying or building your own structures in these environments.

Modern Graphics reports that DrawStructures does not work with CricketDraw, and SuperPaint accesses only 65 of the 67 documents.

The contained structures were created as object-oriented graphics, which you can resize without distortion or loss of resolution. You can use an Imagewriter, LaserWriter, or other PostScript device for output.

The program lets you copy and paste structures into

other Macintosh programs, such as MacWrite. You can also incorporate text into the structures by using Imagewriter or LaserWriter fonts. **Price:** \$79.95.

Contact: Modern Graphics, P.O. Box 21366, Indianapolis, IN 46221-0366, (317) 253-4316.

Inquiry 605.

Neural-Network Demonstration Program

Awareness consists of four programs that demonstrate four neural-network algorithms. The programs are designed to teach you the properties of neural networks. The first program exhibits the computational capabilities of neural networks, such as association. The second program uses a generalized learning rule and demonstrates the exclusive OR (XOR) function, which you can use in learning context-sensitive signal processing. The third program is an example of a neural network that can produce solutions to combinatorial optimization problems. The fourth program deals with complicated controls, such as robotic control strategy.

The program runs on IBM PCs and compatibles with at least 256K bytes of RAM and MS-DOS or PC-DOS 2.0 or higher. It supports various graphics cards and the 8087 floating-point chip, which Neural Systems recommends.

Price: \$130. **Contact:** Neural Systems Inc., 2827 West 43rd Ave., Vancouver, British Columbia, Canada V6N 3H9, (604) 263-3667.

Inquiry 606.

continued

Get Your Hands On More Solutions.

LOGITECH \$99
MOUSE
with Plus Software \$119



Purchase our best selling LOGITECH Serial or Bus Mouse and Plus Package with CADD, Paint and Publisher

software at very affordable prices. Each package is a complete solution that gets you the results you need right now.

CADD Solution \$189

Our Mouse, Plus Software and LOGICADD (Generic CADD 3.0 plus DotPlot). Everything you need to turn your PC into a full featured CADD workstation. It's the complete solution for dimensioned line drawing and CADD.



Paint Solution \$149

Our Mouse, Plus Software and LOGIPAINT (PC Paintbrush). With 11 type fonts and a 16 color palette, it's the paint set that's used by professional and beginning users alike. LOGIPAINT files move easily into both LOGICADD and Publisher documents.

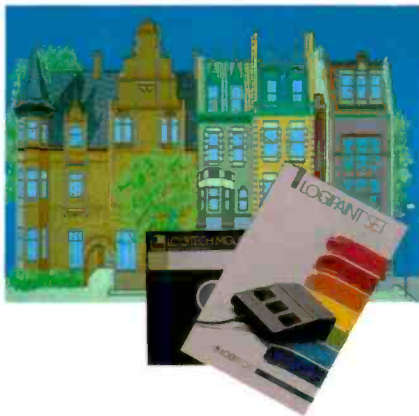

Publishing Solution \$179

Our Mouse, Plus Software and PUBLISHER Software (PFS: First Publisher). It's the complete package that makes it easy to produce high-impact, professional looking documents.

To place a credit card order call our special toll-free number:

800-231-7717

Call toll-free in California:

800-552-8885

YES! I want the LOGITECH Mouse solution!

- LOGICADD Package **\$189**
- w. Serial Mouse and Plus Software
- w. Bus Mouse and Plus Software
- LOGIPAINT Package **\$149**
- w. Serial Mouse and Plus Software
- w. Bus Mouse and Plus Software
- PUBLISHER Package **\$179**
- w. Serial Mouse and Plus Software
- w. Bus Mouse and Plus Software

Add \$6.50 for shipping and handling. California residents add applicable sales tax. Prices valid in U.S. only.

Total Enclosed \$

VISA MasterCard Check Enclosed

Card Number _____ Expiration Date _____

Signature _____

Name _____

Address _____

City _____ State _____

Zip _____ Phone _____

LOGITECH

LOGITECH, Inc.
805 Veterans Blvd., Redwood City, CA 94063
Tel: 415-365-9852

In Europe:
LOGITECH SA, Switzerland
Tel: 41-21-879656 • Telex 458 217 Tech Ch

In Italy:
Algol-Logitech Spa 39-2-215-5622

Generic CADD is a trademark of Generic Software. PC Paintbrush is a trademark of ZSoft Corp. PFS: First Publisher is a trademark of Software Publishing Corp.

Inquiry 162 for End-Users. Inquiry 163 for DEALERS ONLY.

SEPTEMBER 1987 • BYTE 63

Training Your Musical Ear on the Commodore

Ear Training Tutor is a music software program that runs on the Commodore 64 and 128. The tutor drills you through more than 50 preset music lessons, playing musical intervals and triads in all inversions and asking you to name them.

First, you select what you want to be tested on. You can choose to follow the preset lesson structure, or you can design your own lesson parameters using only the specific intervals or triads that require further practice.

You can also choose whether to hear the intervals in ascending or descending order.

The program then plays the intervals or triads and asks you to identify what you hear. When you've answered correctly, the musical notation is displayed on-screen on both the grand staff and a music keyboard. A record-keeping routine keeps track of the lessons you've completed successfully. You can save complete drill text results to disk, including percentage correct and the specific interval/triad attempts and misses. You can also view current or past test results on-screen and send output to a printer.

The program is played through the on-board music chip of the Commodore 64 and 128, or you can hook it up to a Passport-compatible MIDI interface connected to any MIDI synthesizer or to your home stereo system speakers or headphones.

Price: \$59.95.

Contact: MSB Music Software, 35 Hill St., Naugatuck, CT 06770, (203) 723-5275. **Inquiry 607.**

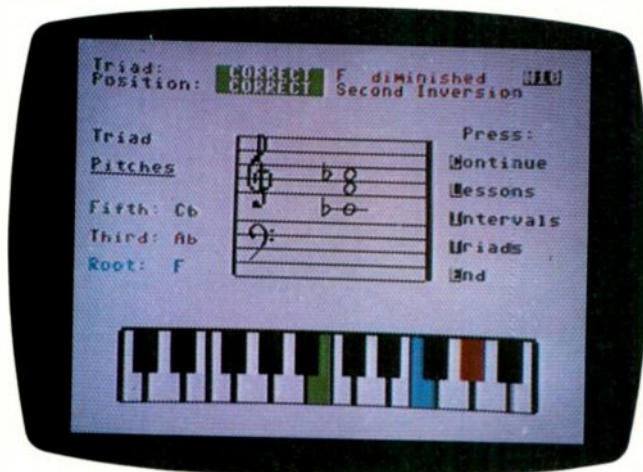

Ear Training Tutor tests your knowledge of music.

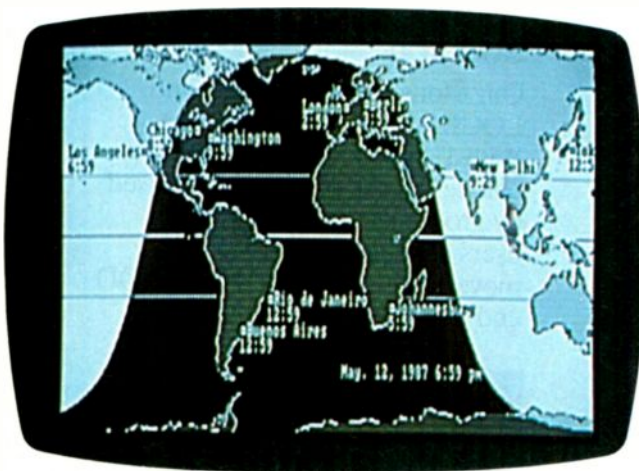

Terminator displays dates and times around the world.

Clockwork Across the World

Terminator draws a line between night and day that moves across a world map in real time. The line position changes with the time of day, and its shape changes with the seasons. In determining the shape and position of the line, the program takes into account the declination of the Sun; the size of the Sun; the refraction caused by the Earth's atmosphere; and the equation of time, which computes the difference between solar and clock time.

You can view the changes by running Terminator in a va-

riety of modes, from 2 minutes to 1 week. You can change modes every second or so, as fast as the program can compute the data that refreshes the screen, Trillium reports. You can display your local date and time along with times in up to 24 cities or time zones anywhere on the map.

You can edit Terminator's setup parameters by choosing to display other cities or time zones or by changing the program's initial values.

Terminator runs on IBM PCs or compatibles with a Hercules monochrome graphics adapter, a CGA or EGA, and at least 128K bytes of RAM.

Price: \$30.

Contact: Trillium, 3770 Highland Ave., Suite 208, Manhattan Beach, CA 90266, (213) 545-8300. **Inquiry 608.**

Decision Maker

Apian Software's Decision Pad helps you evaluate people, plans, and products. It combines elements of spreadsheet and rational decision theory in an interactive decision-making environment.

At the beginning of an evaluation, the program presents you with data-collection forms. You can choose up to 150 alternatives and preferences, and up to 60 criteria per alternative. Then you allocate each to its proper place, using 1- or 2-level weights and 20 positions. You can also incorporate opinions of other people and quantify them, and you can output reports at each step.

Decision Pad includes sample templates for personnel, purchasing, product-marketing, investment, and sales-presentation applications.

The program has Lotus 1-2-3-compatible file-import and -export capabilities, as well as ASCII export.

Decision Pad runs on IBM PCs and compatibles with at least 256K bytes of RAM and MS-DOS or PC-DOS 2.0 or higher. You also need a monochrome, CGA, EGA, or compatible display. A mouse is optional.

Price: \$195.

Contact: Apian Software, P.O. Box 1224, Menlo Park, CA 94026, (415) 851-8496. **Inquiry 609.**

C5.0 has three features professional programmers can't live without.

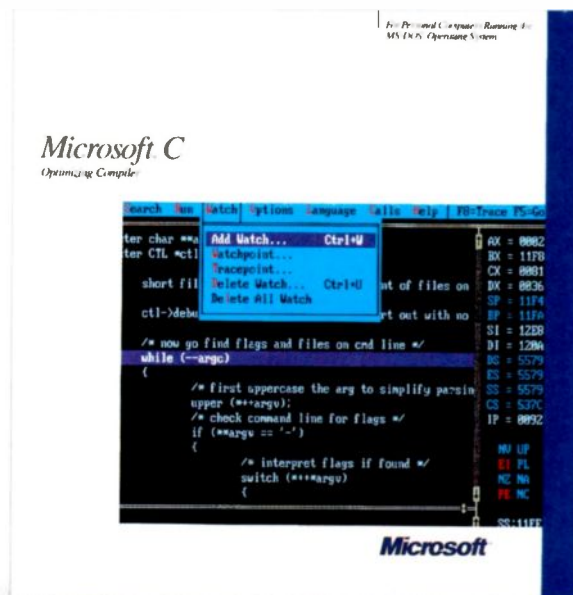

Speed.

Fast Execution Speed.

	Microsoft® C 4.0	Microsoft C 5.0
Sieve (25 iterations)	5.7	3.3
Loop	11.0	0.0*
Float	19.9	0.1
Dhrystone	22.8	19.1
Pointer	14.2	7.4

- New optimizations generate the fastest code:
 - Inline code generation. NEW!
 - Loop optimizations: NEW!
 - Loop invariant expression removal. NEW!
 - Automatic register allocation of variables. NEW!
 - Elimination of common sub expressions.
 - Improved constant folding and value propagation.
- Fine tune your programs for even greater speed:
 - Coding techniques for writing the fastest possible programs are included in the documentation. NEW!
 - Segment Allocation Control:
 - Group functions into the same segment to get faster NEAR calls. NEW!
 - Specify which segments receive variables to yield faster NEAR references. NEW!
 - Uses register variable declarations.
 - Mix memory models using NEAR, FAR & HUGE pointers.

Benchmarks run on an IBM® Personal System/2* *Time is negligible

Speed.

Fast Compilation. Fast Prototyping.

Microsoft C Version 5.0 includes QuickC™, which lets you edit, compile, debug, and execute in an integrated environment. It's ideal for prototyping.

- In-memory compilation at over 10,000 lines/minute. NEW!
- Built-in editor with parentheses, bracket and brace matching.
- Use the integrated debugger to animate through your program, add watch variables and set dynamic breakpoints. NEW!
- MAKE file is automatically generated for you. Simply indicate the modules you want to use, then MAKE recompiles and links only those modules that have changed. NEW!
- Full C 5.0 compatibility:
 - Completely source and object code compatible.
 - Emits CodeView®-supported executables.
 - Identical compile/link command line switches.

And speed.

Fast Debugging.

Microsoft C Version 5.0 includes Microsoft CodeView, our source-level windowing debugger that lets you debug more quickly and thoroughly than ever before.

- Debug larger programs:
 - Debug through overlays created by the Microsoft overlay linker. NEW!
 - Expanded Memory Specification (EMS) support. NEW!
- Fast debugging through precise control of your program execution:
 - Access source level and symbolic debug information from your Microsoft C, FORTRAN, and Macro Assembler programs. NEW!
 - View your source code and assembly simultaneously.
 - Watch the value of variables change as you execute.
 - Set conditional breakpoints.
 - Animate or single step through your program.
- CodeView brings you as close as you've ever been to your hardware:
 - Swap between your code and output screens.
 - Watch your registers and flags change as your program executes.

Microsoft®

C 5.0 will be available soon. If you purchase Microsoft C 4.0 after June 1, 1987, we'll give you a C 5.0 upgrade. Free. For your free information packet, call:
(800) 426-9400.

EVENTS

September 1987

Remote Sensing Society Annual Conference: Advances in Digital Image Processing, Nottingham, England. Dr. P. M. Mather, The University of Nottingham, Nottingham NG7 2RD, England, (0602) 587611. *September 7-11*

Australian Computer Conference '87, Melbourne, Australia. ACC 87 Secretariat, Box 98, East Melbourne, Victoria, Australia 3002, (03) 416 1053. *September 8-11*

Capital Microcomputer Users Forum, Washington, DC. Jackie Voigt, 2111 Eisenhower Ave., Suite 400, Alexandria, VA 22314, (703) 683-8500 or (800) 638-8510. *September 9-10*

Robotic Systems in Aerospace Manufacturing, Fort Worth, TX. Lori Navalta, Technical Activities Division, Society of Manufacturing Engineers, One SME Dr., P.O. Box 930, Dearborn, MI 48121, (313) 271-1500, extension 370. *September 9-11*

SOFTEACH: The Computer Products Training Forum, New York, NY and Atlanta, GA. Softsel, 546 North Oak St., P.O. Box 6080, Inglewood, CA 90312-6080, (800) 325-9189. *September 12-13 and September 19-20, respectively*

Euromicro 87: 13th Symposium on Microprocessing and Microprogramming, Portsmouth, England. Euromicro, Hengelsestraat 705, P.O. Box 545, 7500 AM Enschede, The Netherlands, (31) (53) 338799. *September 14-17*

Simulation Techniques for Personal Computers, Washington, DC. The George Washington University School of Engineering and Applied Science, Washington, DC 20052, (800) 424-9773; in Virginia, (202) 994-6106. *September 14-18*

1987 Electronic Printer and Publishing Conference, Miami, FL. Jean O'Toole, CAP International, One Snow Rd., Marshfield, MA 02050, (617) 837-1341. *September 14-18*

Software Licensing Agreements: Buying, Selling, and Protecting Rights, Princeton, NJ and Atlanta, GA. Ann Molinari, DTI, Lakeview Plaza, P.O. Box 2429, Clifton, NJ 07015, (201) 478-5400. *September 15 and September 22, respectively*

ICCC-ISDN '87: Integrated Services Digital Network, Dallas, TX. Jane Farthing, Bell Atlantic, 1310 North Court House Rd., Arlington, VA 22201, (703) 974-5435. *September 15-17*

Midcon/87, Chicago, IL. Dale Litherland, Director of Education, Midcon/87, 8110 Airport Blvd., Los Angeles, CA 90045-3194, (800) 421-6816; in California, (800) 262-4208. *September 15-17*

Computer Graphics: A Comprehensive Introduction, Palo Alto, CA. Marilyn Martin, Integrated Computer Systems, 5800 Hannum Ave., Culver City, CA 90231-3614, (800) 421-8166; in Canada, (800) 267-7014. *September 15-18*

Real-Time Operating Systems: A Hands-on Workshop, Los Angeles, CA and Washington, DC. Tom Watson, Integrated Computer Systems, 5800 Hannum Ave., Culver City, CA 90231-3614, (800) 421-8166; in Canada, (800) 267-7014. *September 15-18 and September 29-October 2, respectively*

Effective Skills for Technical Managers, Los Angeles, CA and Boston, MA. Marilyn Martin, Integrated Computer Systems, 5800 Hannum Ave., Culver City, CA 90231-3614, (800) 421-8166; in Canada, (800) 267-7014. *September 15-18 and September 22-25, respectively*

Visions '87 Computer Graphics Conference, Springfield, MO. Steve Finley, Department of Art and Design, Southwest Missouri State University, Springfield, MO 65804, (417) 836-5110. *September 18-19*

Interex HP 3000 Users Conference, Las Vegas, NV. Interex, Conference Department, 680 Almanor Ave., Sunnyvale, CA 94086, (408) 738-4848. *September 20-25*

Engineering Workstations Conference, Los Angeles, CA. Corporate Expositions Inc., P.O. Box 3727, Santa Monica, CA 90403. *September 21-23*

CD-ROM Expo, New York, NY. Dorothy Ferriter, 375 Cochituate Rd., P.O. Box 9171, Framingham, MA 01701-9171, (800) 343-6474; in Massachusetts, (617) 879-0700. *September 22-23*

Northcon/87 Electronic Show and Convention, Portland, OR. Dale Litherland, Director of Education, Northcon/87, 8110 Airport Blvd., Los Angeles, CA 90045-3194, (213) 772-2965. *September 22-24*

Integrated Voice/Data Communications and ISDN, Palo Alto, CA. Evelyn Black, Integrated Computer Systems, 5800 Hannum Ave., Culver City, CA 90231-3614, (800) 421-8166; in Canada, (800) 267-7014. *September 22-25*

Fourth Annual International Forum on Micro-Based CAD, Raleigh, NC. Gene Fernaro, C. C. Mangum Building, North Carolina State University, 3016 Hillsborough St., Raleigh, NC 27695-7902, (919) 737-2356. *September 23-25*

Writing Better Computer Software Documentation for Users, Atlanta, GA. Deidre Mercer, Department of Continuing Education, Georgia Institute of Technology, Atlanta, GA 30332-0385, (404) 894-2547. *September 23-25*

Information Systems Perspectives Symposium, San Francisco, CA. GUIDE Headquarters, 111 East Wacker Dr., Suite 600, Chicago, IL 60601, (312) 644-6610. *September 27-30*

Defense and Government Computer Graphics Conference, Washington, DC. Defense and Government Computer Graphics Conference, P.O. Box N, Wayland, MA 01778, (617) 358-5356. *September 28-October 1*

Ninth Annual Electrical Overstress/Electrostatic Discharge Symposium, Orlando, FL. EOS/ESD Symposium, P.O. Box 14, Gillette, NJ 07933, (201) 522-4770. *September 29-October 1*

INFO '87: Information Management Exposition and Conference, New York, NY. Show Manager, INFO '87, 999 Summer St., Stamford, CT 06905, (203) 964-0000. *September 29-October 2* ■

Send notice of your organization's public activities at least four months in advance; we will publish them as space permits. Please send them to BYTE (Events), One Phoenix Mill Lane, Peterborough, NH 03458.

ALL IT LACKS IS

A choice of snap-in/out, 24- or 18-pin print heads gives you the versatility and ease of maintenance that other printers lack.

With a top speed of 360 cps, it makes most printers seem downright lackadaisical.

ALPS P2400C

But who needs competition when you've got all this?

Namely, the ALPS P2400C™ Dot Matrix Printer.

No other printer in its class can do so much for so many for so little.

For instance, the P2400C can easily take on all the work an office full of busy PCs can dish out.

And take care of it faster. Thanks not only to its talents pointed out above, but to its many others, as well.

Like a choice of draft, correspondence and letter quality print modes. A print buffer expandable to 256K. Multiple font cartridges. And full compatibility with the most popular PCs and software.

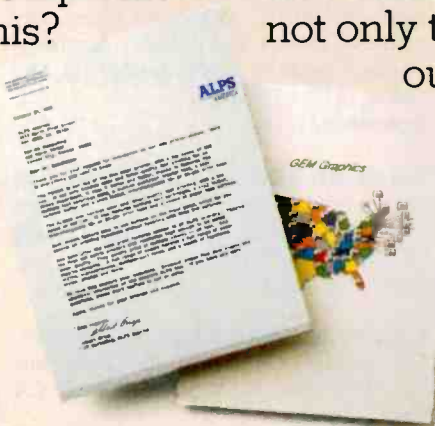

For letters, seven-color graphics, spreadsheets or whatever, its output is so brilliant, everything else appears lackluster.

COMPETITION.

Most printers lack the good sense to include a paper-saving, push/pull tractor for both bottom and rear feed. Not this one.

You also get conveniences that many other printers are lacking. Like control of everything from the front panel, the feature menu, or from software – without using DIP switches.

Not to mention the ability to run quietly. At under 55dBA, the P2400C is one of the least noisy printers around.

One of the most durable, too. It comes with a full, one-year limited warranty. And if you give it normal care, it'll give you over five years of trouble-free performance.

Of course, there's nothing like a live performance to prove there's nothing like the P2400C.

For a free demo, or more information, call us at (800) 828-ALPS. In California, (800) 257-7872.

And see what every other dot matrix printer is lacking.

ALPS
AMERICA

IT'S TIME YOU SAW THE ALPS.

ASK BYTE

Conducted by Steve Ciarcia

Nothing's Too Good

Dear Steve:

I am trying to optimize the performance of the hard disks in some IBM PCs and compatibles. Some of them take much longer to read tracks than others do, and I think part of the problem may be due to an incorrect interleave factor.

I would also like to change the number of bytes per sector for some special storage problems I have, but I can't find any information on how to do this low-level formatting. Even though the disk-controller cards are made by different manufacturers, they are interchangeable. Where would I find out how to do low-level formatting for both hard disks and floppy disks? I don't mind doing it in assembly language.

Phil Mumma
Redwod City, CA

Be careful about changing things down deep in the hardware. Many things can go wrong if you're not absolutely certain about what you're doing.

*First, you should use CHKDSK to see how fragmented your files are. If the PC has to do a lot of seeks to get all the data, it'll take longer to read a file. Simply type CHKDSK *.* and read the report. Compare the results from running CHKDSK on two PCs with differing times and see if there's any relation between the degree of fragmentation and the speed. You'll need to do that in each subdirectory on the hard disk; files that aren't listed are contiguous.*

There are several utilities on the market that will defragment the files. Pick up a copy of PC Magazine and look through the products in the disk optimizer category. I've used a public domain program called DOG (which stands for disk organizer) that I downloaded from CompuServe quite a while ago. It's a bit of a pain to use, but it works just fine. You can also download it from BIX.

You'll need to defragment files on a regular basis. I do mine after every complete disk backup, so if anything goes wrong I've got the data ready to reload.

Once you've got all your files contiguous, see if the problem goes away. If it doesn't, only then will it be worthwhile to change the interleave factor. To do that, you need a low-level formatting program that works with the particular controller

card you've got and that allows you to select an interleave factor. Where to get the formatter is a good question; for starters, try the folks who sold you the card, or try a computer club.

You'll have to back up everything on your disk before you reformat it. The default interleave is 6, and I suspect that you're kidding yourself if you try anything below 3. Remember that if an interleave factor is too low for the program, you have to wait for one complete disk rotation for each sector that's read or written. This translates to a dramatic increase in time. The penalty for an interleave that's too high is relatively minor, so I bet you won't notice a significant change until you drop below the threshold and the time taken suddenly gets much worse.

Don't even think about changing the sector size! In principle this is easily done, but because it's so rarely attempted, the code in DOS to handle it hasn't been extensively tested. I've heard of several bugs in various versions of DOS that come to the fore when you try working with disks whose sector size you've altered.

A better approach to the whole problem is to use the BUFFER= statement in the CONFIG.SYS file to increase the number of DOS disk buffers. This will improve read performance quite a bit, particularly if you're doing random access to files. Sequential reads of all sorts won't improve much, simply because the buffers don't read far ahead. Writes won't improve at all because DOS writes through the buffer.

You might want to look into add-on disk-caching products that improve DOS's buffering. I'm not convinced that they're worth it, but if you've got a critical application you should look into them.

If your data is read-only, it's an ideal candidate for a RAM disk. You can get EMS (expanded-memory specification) RAM boards with 4 megabytes for under \$1000 nowadays, so the only delay you'll experience is loading the memory up in the morning.—Steve

Ear to the Ground

Dear Steve:

I have an amateur interest in both earthquakes and computers. For several

years, I have been recording earthquakes from all over the world on a homemade seismograph. (A 1979 article in *Scientific American* described how to build one.) The seismograph is simple: a weighted pendulum with a magnet, suspended near a 10,000-turn coil. Voltages induced in the coil by the relative motion of the coil (resting on the earth) and the magnet (suspended and free to swing) are amplified by a 741 op-amp-based amplifier and are used to drive a Heathkit chart recorder. I have recorded earthquakes as far away as Alaska with this setup.

I'm writing to you for help in moving this setup into the computer age. I would like to eliminate the chart recorder (which costs a fortune in paper every month anyway), send the voltage from the amplifier into an A/D converter, and sample the digitized waveform at a healthy rate (say, 20 times per second) with my IBM PCjr.

I've read your Circuit Cellar article on parallel interfacing (July 1986 BYTE), and it explained nicely why someone here at work suggested that I'd probably need an 8255-5 as well as an ADC0809. However, no one that I know has been able to point me to any kind of usable circuit, much less get me instructions on how I might interface it to my computer.

I have located a company in Minnesota that sells a prototype add-on "sidecar"

continued

IN ASK BYTE, Steve Ciarcia answers questions on any area of microcomputing. The most representative questions received each month will be answered and published. Do you have a nagging problem? Send your inquiry to

*Ask BYTE
c/o Steve Ciarcia
P.O. Box 582
Glastonbury, CT 06033*

Due to the high volume of inquiries, we cannot guarantee a personal reply, but Steve and the Ask BYTE staff answer as many as time permits. All letters and photographs become the property of Steve Ciarcia and cannot be returned.

The Ask BYTE staff includes manager Harv Weiner and researchers Eric Albert, Bill Curlew, Ken Davidson, Jeannette Dojan, Jon Elson, Roger James, Frank Kuechmann, Dave Lundberg, Tim McDonough, Edward Nisley, Dick Sawyer, Andy Siska, Robert Stek, Mark Voorhees, Steve Smith, and Charles Skiles.

Microsoft QuickBASIC 3.0's speed was verified by an indisputably independent test.

...not included...
...ess, returning to the editor at the offending...
...achievement for the price. ■

	Turbo BASIC	QuickBASIC 3.0
Sieve:		
• 25 Iterations/1,899 Primes	3.241	3.023
Graphics: (Screen Mode 8 — EGA)		
• Draw 500 Circles	5.328	4.729
• Draw 3,200 Circles	11.422	5.051
• Draw 5,000 Boxes	10.598	5.988
• Draw 3,200 Vertical Lines	9.391	4.949
• Draw 20,000 Horizontal Lines	15.766	5.551
• Fill 200 Circles	7.689	6.431
Math:		
• Integer Math		
• Floating Point, Single Precision	4.284	4.230
• Sines and Cosines (7,200)	8.184	1.805
• Single Precision EXP	15.599	4.887
	13.731	3.742
Matrix Operations:		
• Borland's Test		
• Microsoft's Test	0.714	0.055
• Bubble Sort (1,000 Integers)	34.328	4.781
	2.856	2.477
File I/O:		
• Sequential (2,000 records)	21.696	7.531
• Random (2,000)	52.234	51.078
Text I/O:		
• Screen Mode 0 (5,000 characters)	0.934	1.750
• Screen Mode 1 (5,000 characters)	9.447	9.008
• Screen Mode 2 (5,000 characters)	4.339	4.070

In the May 5, 1987 issue of *PC WEEK*, some interesting benchmarks were published. We won virtually all the tests, but one test in particular caught our attention: the competitor's. Now even they have to agree we're faster.

Microsoft® QuickBASIC 3.0 gives you the fastest execution speed. It also lets you write code faster. That's because you pick up speed working in an integrated programming environment which includes our unique integrated debugger.

With our debugger, you can view source code and program output simultaneously.

And you can see the contents of variables while your program is running. Even set dynamic breakpoints.

Get your hands on Microsoft QuickBASIC 3.0. Right now, we'll make it easy because we're offering a \$20.00 rebate.* And to be sure that you're satisfied, we're offering a 30 day money-back guarantee. So there's no better time to do some independent testing of your own.

Microsoft®

For a reprint of the article, just give us a call at (800) 426-9400. Benchmarks reprinted with permission of *PC Week*.

Microsoft and the Microsoft logo are registered trademarks of Microsoft Corporation. *See specially marked packages for details. Offer valid only in U.S.A.

Inquiry 180 for End-Users. Inquiry 181 for DEALERS ONLY.

SEPTEMBER 1987 • B Y T E 69

PROM/PAL PROGRAMMING?

From \$250.00

Finding a Low-Cost PROM or PAL* programmer is only half of the battle. Finding a company that won't desert you when you need support or service is the other half.

Logical Devices Products cost you less because we offer the best price performance ratio in the market, and because once you buy our products you will experience less down time and more reliable operation than most other units. In addition you get features that were evolved from our years of experience of serving people who program chips.

We offer a wide range of products from dedicated programmers to universal software driven models.

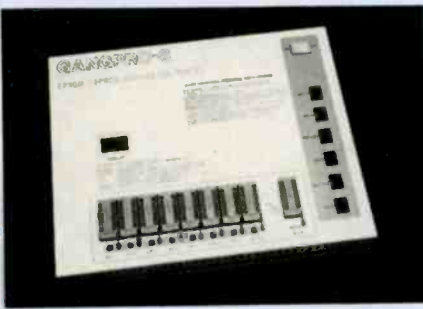

GANGPRO-8 production programmer. 8 EPROMs to 27512 with RS-232 option.

PROMPRO-8X universal portable. RS-232. Programs PROMs/PAL*s/ micros

PALPRO-2X Low Cost PAL* only programmer. Dedicated, RS-232 unit.

SHOOTER Low cost EPROM only programmer. RS-232, Stand-Alone.

PC-PRO IBM PC plug-in EPROM card 2716-27512

ALLPRO pin driven software based universal unit, programs every imaginable fuse programmable IC.

CAST boolean software/silicon compiler for PLDs. JEDEC output

UV ERASERS FROM \$59.95

All products carry 90 day Warranty & 14 day Money Back Guarantee

CALL 1-800-331-7766
LOGICAL DEVICES INC.

USA 305-974-0967
ENGLAND 44 272 277323
FRANCE 39.54.91.13

*PAL IS A REGISTERED TRADEMARK OF MONOLITHIC MEMORIES INC.

ASK BYTE

for the PCjr for \$39. This board has a 60-pin connector that attaches to the PCjr but is otherwise unpopulated. What I'd like to do is wire-wrap the A/D circuitry onto this prototype board.

I had a chance to play with the IBM Data Acquisition and Control Adapter on a regular PC for a couple of weeks. During that time, I wrote some software to read the A/D adapter and display a time-varying voltage trace on the high-resolution graphics screen. Unfortunately, this card does not fit into the PCjr; besides, it costs over \$1500 (it is packed with other functions, such as timers, D/A, and binary I/O). So my software is all set to go, but I have no hardware background on this stuff.

Can you help me out? I've tried all the sources I know of, without any luck.

Ted Blank
Wappingers Falls, NY

Actually, I think there's a more inexpensive way to do the deed—use the joystick input on your PCjr. Because the voltage output from the seismograph varies so slowly, you don't need a fancy A/D converter or all the complexity that goes along with it.

The joystick ordinarily works with a variable resistor between the input pin and +5 volts. The resistor determines the charging current for the timing capacitor. Anything that can stuff a suitable current into the capacitor will give pretty much the same results.

You probably already have a joystick, so there's no need to build a special cable

that needs the funny Berg connector. Take the joystick apart and measure the voltages at either end of the x-axis potentiometer. One side will be at +5 volts, and the other (the input to the PCjr) will be somewhat lower. Because you need a ground connection, too, measure the voltages on one of the buttons: One side is ground, and the other is about +5 volts. (This would be simplified if I had a PCjr joystick reference manual handy.)

Next, the electronics for the seismograph:

The output of the amplifier circuit you have now is in the ballpark of 10 millivolts. What you need is a current in the range of 10 to 50 microamps. The solution is a voltage-to-current converter with a bit of amplification. The schematic in figure 1 diagrams something that should work. (Bear in mind that I haven't actually built this thing, so you'll have to do some fiddling to get it to work.)

To get the circuit calibrated, close the zero set switch and adjust the offset current potentiometer for zero volts at the wiper arm (you could use a switch there, too). Adjust the balance potentiometer for zero volts out of the 741.

Now enter the following BASIC program into your PCjr:

```
10 WHILE 0 = LEN(INKEY$)
20 PRINT STICK(0),STICK(1),
   STICK(2),STICK(3)
30 WEND
```

This will display the joystick input values
continued

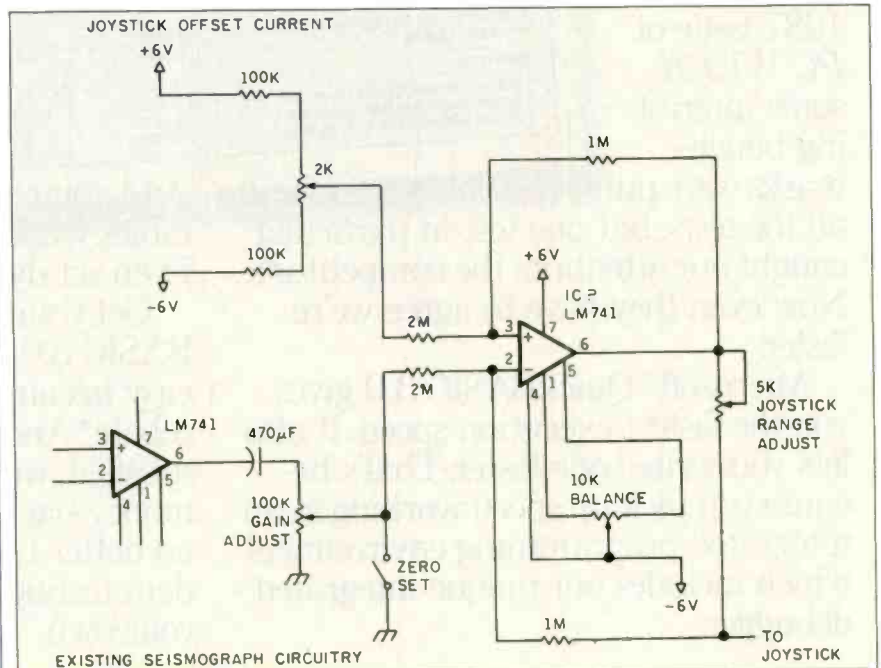

Figure 1: Amplifier circuit for seismograph.

Order Status,
Technical & Other
Info. (602) 246-2222



SPECIAL
WORD PERFECT
\$195

Call for programs
not listed

TOLL-FREE ORDER LINE 1-800-421-3135

FREE SOFTWARE!

Purchase over \$100 and receive one of these disks absolutely FREE! Purchases over \$250 get two free disks, over \$400 get three, or get all four disks when your purchase is over \$500! **1) MIXED BAG** — A great assortment of utilities and games all packed on one disk. **2) PC-WRITE** — Try this famous feature packed word processor. It's a winner! **3) FONT-SET** — Lets you set popular fonts like bold, underline, etc. on most late model printers from Citizen, Epson, NEC, Okidata, Panasonic, Star, Toshiba, etc. You can even use your printer like a typewriter! **4) ABC-LIST** — Great mailing list program! Sort on any field, do qualified searches, print reports and mailing labels, and more!

— SOFTWARE —

ACCOUNTING

BPI AP, AR, PR, GA \$169 ea.
Cyma Call
Dac Easy Accounting 39
Dollars & Sense 94
Managing Your Money 3.0 117

COMMUNICATION PROGRAMS

Carbon Copy Plus 115
Crosstalk 89
Remote 89
Smartcom II 83

DATA BASE MANAGERS

Clipper 380
Clout 2 Call
Condor III 310
Knowledgeman II Call
Powerbase 2.2 169
Q&A Call
Quickcode 138
Quicksilver 295
Quickreport 138
Revelation 469
R: Base System V 425

EDUCATIONAL

Flight Simulator 28
Turbo Tutor II 25
Typing Tutor III Call

GRAPHICS

Chartmaster Call
Energraphics 2.01 294
In-A-Vision 275
Microsoft Bus Mouse 106
Microsoft Chart 164
Microsoft Serial Mouse 119
Newsroom 31
OPTI Mouse W/DR Halo II 96
Printshop 33
Signmaster Call

INTEGRATED

Ability 59
Enable 355
Smart Software Call

LANGUAGES

Lattice C Compiler \$242
Microsoft C Compiler 249
Microsoft Fortran 4.0 255
Microsoft Macro Assembler 84
Microsoft Pascal Compiler 166
Microsoft Quick Basic 3.0 55
Ryan McFarlan Fortran 305
Ryan McFarlan Cobol 479
Turbo Basic 55
Turbo C 55
Turbo Pascal w/8087 + BCD 55

PROJECT MANAGER

Harvard Total Project II 326
Microsoft Project 219
Super Project Plus Call
Timeline 2.0 242

SPREADSHEET

Microsoft Multiplan 108
Spreadsheet Auditor 3.0 82
Supercalc 4 Call
VP Planner 49

UTILITIES

Copy II PC 19
Copywrite 39
Desqview 2.0 72
Double Dos 30
Fastback 85
Graph in the Box 55
Homebase 39
Microsoft Windows 55
Norton Utilities 3.1 48
Prokey 4.0 70
Q DOS 49
Sidekick (unprotected) 55
Sideways 3.1 39

WORD-PROCESSING

Easy Extra 88
Microsoft Word Call
Multimate Advantage II Call
Volkswriter 3 139
Webster Spellcheck 37
Word Perfect 195
Wordstar 162
Wordstar Propac 233
Wordstar 2000+ 206

— HARDWARE —

ACCESSORIES

Copy II PC Board 75
150 watt power supply 69
Mlni Micro Parallel
Print Buffer 69
Masterpiece 88
Masterpiece Plus 99

BOARDS

AST Advantage Premium Call
AST Premium Sixpac Call
AST Sixpac (384K) 229
Hercules Color Card 145
Hercules Graphics + 182
Intel Above Boards Call
J Laser (Tall Tree) Call
J Ram 3 (Tall Tree) 169
J Ram 3 AT (Tall Tree) 207

COMPUTERS

AZ 386

80386-16 Micro Processor,
1 MB of Ram, Teac 1.2 MB
disk drive, 220 watt power
supply, 6 layer mother board,
RT keyboard \$2995

AZ TURBO XT

IBM Compatible Computer,
135 watt power supply,
1 brand name floppy disk,
1 parallel port, 1 serial port,
1 game port, PC keyboard,
640K Ram, 8 expansion slots,
8088-2 processor ... \$519⁰⁰

AZ TURBO AT

IBM AT Compatible, 512K,
6 & 8 MHZ, keyboard
graphics card, 220 watt
power supply, MS/DOS 3.2
GW Basic \$1025

AST 286

PREMIUM COMPUTER

512K, expandable to 2MB
on the system board, RT
enhanced style keyboard,
parallel, serial and clock,
1.2 MB floppy disk drive,
7 expansion slots, two 32
bit fastram slots, DOS 3.1
& Basic
1 year warranty Call

EGA BOARDS

GBI Board Call
Paradise Auto Switch 480
EGA Card 230
Quad EGA Plus Call
Vega Deluxe 299

EGA MONITORS

AMDEK 722 455
Casper EGA Call
NEC Multisync 559

HARD DRIVES

AZ 20 MB Hard Card 425
AZ 30 MB Hard Card Call
Filecard 20 MB 499
Maynard 20 MB Hard Card Call
Plus Hardcard 20MB Call
Seagate 20 MB Int. w/cont. 309
Seagate 30 MB Int. w/cont. 349
Seagate 30 AT Int. 515

KEYBOARDS

Keytronics 5151 162
Keytronics 5153 269
RT Style Keyboard 89

INCREDIBLE VALUES

Nationally advertised boards for IBM PC and most compatibles at give away prices.
Keyboards (similar to 5151) \$79
Monochrome Board w/printer port (similar to Hercules Graphics) \$79
Expansion Board 0 to 576K \$42
Multifunction Board w/game port (similar to AST six pack) \$79
Four Drive Floppy Controller \$39
Color Card w/o printer port \$69
Color card w/printer port \$79

MODEMS

Everex 300/1200 89
Hayes 1200 Call
Hayes 1200B Call
U.S. Robotics Courier 2400 ... 339
U.S. Robotics Passwd. 1200 .. 180

MONITORS

AMDEK 410 Amber 157
AMDEK 600 339
Magnovox Color RGB Call
Princeton Max 12 138
Samsung TTL Amber 72
Samsung TTL Green 70
Samsung Color w/tilt/turn ... Call

PRINTERS

CANON LASER
CITIZEN
MSP-10 249
MSP-15 315
MSP-20 285
Premiere 35 Dalsywheel 459
EPSON - Call on all models
LASER IMAGE 2000 Call

NEC
NEC P5XLP 959
NEC P7 Parallel 619
NEC 8850 1059
NEC P6 Parallel 439
NEC P960XL 1150
NEC Laser Call
OKIDATA - Call on all models

PANASONIC
1080-I 155
1091-I 179
1092-I 295
1592 372
KXP3151 368

STAR MICRONICS
NP10 139
NB24-10 437
NX10 160
NX15 306

TOSHIBA - Call on all models
RAM
64K 150NS (set of 9) 16.50
256K 150NS (set of 9) 33
256K 120NS (set of 9) Call

TERMS: Shipping on most software is \$5.00. AZ orders +6.7% sales tax. Personal check/company check - allow fourteen (14) days to clear. We accept purchase orders from authorized institutions for 3.9% more than cash price. All returns are subject to our approval. There will be a 20% restock fee. Minimum phone order \$50. All prices are subject to change. Due to copyright laws we cannot take back any open software.

No Charge for Master Card or Visa



We do not guarantee compatibility

TOLL-FREE ORDER LINE 1-800-421-3135
WAREHOUSE DATA PRODUCTS
2701 West Glendale Ave. • Phoenix, AZ 85051

Phone Hours: Monday, Wednesday & Thursday 7 am-9 pm; Tuesday & Friday 7 am-5 pm; Saturday 9 am-5 pm. MST.

MicroCom Systems OUTSTANDING SOFTWARE

For IBM PC's and Compatibles

\$350 PER
DISK

SMALL QUANTITIES

\$300 PER
DISK

FOR TEN OR MORE

\$1 OFF 5 DISKS OR MORE WITH THIS COUPON

- BUSINESS 1**—EZ-Forms business form generation, completion and printing program.
- CAD 1**—Altamira, a 4 color object oriented drawing program. Color required.
- COMM 4a,b,c,d,e**—(5 disks) RBBS Bulletin Board System 14.1D.
- DATABASE 1a,b**—(2 disks) File Express menu driven general purpose database mgr.
- EDUCATION 1**—Interactive DOS tutorial for new PC users. Makes learning DOS painless.
- GAMES 1**—3-D PacMan, Kong, SpaceWar, JanitJoe, and more. Color required.
- GAMES 2**—Qubert, Pango, Centipede, Monopoly, Zoarre, and more. Color required.
- GAMES 3**—Blackjack (you set rules), Arm Chair QB, and Empire (War Game).
- GAMES 4**—Castle, StarTrek, and the original Colossal Caves Adventure.
- GAMES 5**—The Hack adventure game from the universities. Like Rogue, only more complex.
- GAMES 6**—Pinball, Dthello, Dragons, Sopwith (fly one), and more. Color required.
- INFO 1a,b**—(2 disks) Cooking recipes database with keyword/ingredient retrieval.
- LANGUAGE 5**—Turbo Pascal interactive debugger, pop-up help, formatters, et cetera.
- LANGUAGE 7**—Complete Pascal interpreter/compiler. Great for learning Pascal!
- ORGANIZER 1**—DeskMate, a Sidekick clone, and the Judy calendar program.
- PINUP 2**—Provocative high res digitized graphics pinups. Graphics required.
- PRINTER 1**—Font and sideways utilities, spoolers, banner makers, and more.
- UTILITIES 1**—A collection of invaluable general purpose DOS utilities. A must!
- UTILITIES 2**—More invaluable DOS utilities. Too many to list here!
- UTILITIES 3**—A comprehensive set of debugging and diagnostic utilities.

NEW RELEASES/UPDATES

- CAD 2a,b**—(2 disks) An advanced 2D/3D drafting prog. 640k and color required.
- COMM 1a,b**—(2 disks) Version 2.4 of the ever-popular Qmodem comm. program.
- COMM 2a,b**—(2 disks) Procomm 2.42, an excellent modem program with terminal emulation.
- EDUCATION 2**—Learn the Presidents, States (and capitals) and more. Color required.
- EDUCATION 5**—Learn Drigami, the Japanese art of paper folding. Color required.
- FINANCES 3a,b**—(2 disks) Express Calc 3.12, a powerful spreadsheet program.
- GAMES 8**—Striker helicopter attack, and Risk, world domination. Color required.
- GAMES 9**—EGARisk, the game of world domination in very high resolution. EGA required.
- GAMES 10**—Solitaire, Teed-Off golfing, and Sailing in the Bermuda triangle. Color required.
- GAMES 12**—MyChess (9 levels), Backgammon, and Wheel of Fortune. Color not required.
- GRAPHICS 1**—Record and play back screen images! Excellent for demo, etc. Color required.
- INFO 2a,b**—(2 disks) Zip-Phone, national areacode/ prefix to zip-code cross reference.
- LANGUAGE 3a,b**—(2 disks) The A86 2.18 macro assembler and debugger.
- SHELL 4**—Automenu and HDM II 4.04 hard disk menus. Create custom full-screen menus.
- UTILITIES 5**—Utilities for formatting, parking, and optimizing hard disk drives.
- UTILITIES 6**—Advanced utilities including Dpath, Esc, Hotdos, Resident program utilities.
- UTILITIES 7**—More Advanced utilities including MasterKey (undeletes files from hard disks).
- WORD 1a,b**—(2 disks) PC Write 2.71, a powerful word processing system, w/spell checker.

Catalog available, add \$2. 3.5" format add \$1/disk.

MicroCom Systems	Cost of Items	
3673 Enochs Ave.	Ship/Handling	\$1.00
Santa Clara, CA 95051	CA Res. Tax	
408-737-9000	Total Enclosed	



(415) 325-6500

M-F 7am-9pm

Sat-Sun 8am-5pm

BY-9/87

CIARCIA FEEDBACK

so you can see what's going on. If you've got it wired up right, watch the first number (from STICK(0)).

Tap the seismograph so that you get a signal to play with and open the zero set switch. Set the range potentiometer to about midrange and adjust the offset potentiometer so that the minimum number is about +10 or so. Set the range pot so that the maximum number is around +200. These two settings interact, so you'll need to twiddle both of them to converge on the right settings.

Eventually you should have a slight oscillation going, with reasonable joystick values coming back. Now you can establish some software-conversion factors that relate the numbers you get from the STICK() function with the familiar values on the strip-chart recorder. I think you can use the PCjr and the recorder at the same time, but it's worth checking to make sure that the new circuitry doesn't load it down.

The rest of the software is up to you.

Incidentally, some older 741 op amps suffer from what's known as "popcorn" noise: The output voltage abruptly bounces from one supply voltage to the other. If you're listening on a speaker, it sounds a lot like popcorn popping. If the output to this circuit shows unexplained spikes, try replacing the 741s with newer versions.—Steve

Squeaky Disk

Dear Steve:

The carbon brush on my 10-megabyte IBM hard disk drive squeaks. My dealer's service department fixed it once, but the squeak recurs. I called IBM and they want \$565 to exchange the disk drive for a new one with a very short warranty.

I thought I might try a tiny amount of graphite lubricant. If this is inadvisable, please let me know. Any help you can give is appreciated.

Kenneth L. Kayser
Milwaukee, WI

You've got the right idea. Pull the drive apart and put the tiniest possible drop of lubricant on the brush.

The noise occurs because the rounded end of the spindle has worn a divot in the carbon brush. The divot catches on the spindle and oscillates at exactly the right frequency to make your hair fall out. The spring, of course, is a resonant, lightly damped structure.

You can also try bending the support spring a bit to move the divot off-center from the spindle. This will work until the spindle wears a divot in the new location, but that can take a long time. Eventually you'll wind up with several divots that merge into one pothole, and the problem

will go away. Be careful when you've got the drive out. Do not rotate the spindle or the head actuator; the heads are in contact with the platters, and you will do irreversible damage if you move things around.

Resist the engineer's normal temptation to fiddle with the mechanical objects. Just do the job, put it back together, and count your change.

A little lubricant is better than a lot. Don't go hog-wild with a can of WD-40, the way you might under a hood with automotive troubles.—Steve

CIRCUIT CELLAR FEEDBACK**New on the Block**

Dear Steve:

I'm very interested in building the projects you present in BYTE, but I'm 15 years old and the only computers I have access to are an AT&T PC 6300 and an Apple II+. Also, I don't know a thing about electronics. I want to learn, but I don't know where to start. Can you help?

Chris Mulberry
Golden, CO

We were all beginners once, so it's nothing to worry about. A good source of basic electronics books and information is your local school or public library. Magazines such as Modern Electronics (available on most newsstands) publish much material useful to beginners.

There are several good hardware-oriented books available on interfacing the Apple. These include:

Blankenship, John. The Apple House. Englewood Cliffs, NJ: Prentice-Hall, 1984.

Sather, James. Understanding the Apple II. Chatsworth, CA: Quality Software, Computer Book Division, 1983.

Sather, James. Understanding the Apple IIe. Chatsworth, CA: Quality Software, Computer Book Division, 1985.

Titus, Jonathan, et al. Apple Interfacing. Indianapolis, IN: Howard W. Sams, 1981.

Titus, Jonathan, et al. Microcomputer—Analog Converter Software and Hardware Interfacing. Indianapolis, IN: Howard W. Sams, 1978.

Uffenbeck, John E. Hardware Interfacing with the Apple II Plus. Englewood Cliffs, NJ: Prentice-Hall, 1983. (This last book uses a different bus-connector-pin numbering than that used in the Apple manuals and every other Apple interfacing book. This can be confusing.)

continued



1967: The first coronary bypass operation is performed. Fred Molinari, President, is there.

Announcing the most important bypass operation since 1967.

Introducing **DT-Connect**

Observing the first coronary bypass operation, Fred Molinari was struck by an inspiration.

"The PC AT's I/O is so slow—the bus is like a clogged artery!"

So he considered, "Wouldn't bypassing the host bus with an external, direct connection between acquisition boards and processor boards allow them all to run much faster?!"

Then, he fainted.

20 years later, Fred developed **DT-Connect**, an open interface specification permitting the direct connection of analog I/O or frame grabber boards to array processor boards.

Based on 16-bit tri-stated external I/O data ports and simple handshaking protocols, the **DT-Connect** interface eliminates the need for data to flow through the limited I/O of the host PC AT. Data flows faster, from 0 Hz to 10 MHz, speeding signal (DSP) and image processing on the IBM PC AT.

Best of all, many new Data Translation analog I/O, frame grabber, and array processor boards incorporate the **DT-Connect** interface. So they are superfast, and supercapable.

Call us for more information. But have smelling salts handy. The processing speed of **DT-Connect** isn't for the faint of heart.



Call (617) 481-3700.

◀ **DT-Connect** is an open interface specification which permits the direct connection of stand alone data acquisition and frame grabber boards to processor boards for greatly accelerated signal (DSP) and image processing.

DATA TRANSLATION[®]

World Headquarters: Data Translation, Inc. 100 Locke Dr., Marlboro, MA 01752 (617) 481-3700 Tlx 951 646

European Headquarters: Data Translation Ltd., 13 The Business Centre, Molly Millars Lane, Wokingham, Berks, RG112JQZ, England UK Tlx 849862 (#D)

International Sales Offices: Australia (61) 2-662-4295; Belgium (32) 2-7352135; Canada (416) 625-1907; Chile (2) 2-253689; China (408) 727-8222, (86) 8-721-4017; Denmark (45) (02) 187188; England (44) 734-79383; Finland (358) 90-372144; France (33)(1) 69-28-01-73; Greece (30)(3) 152-7039, (30)(1) 361-4300; Hong Kong (852) 3-318585; India (91) 2-231040; Israel (972) 3-324298; Italy (39) 2-81821; Japan (81) (3) 502-5550, (81) (3) 375-1551, (81)(3) 355-1111; Korea (82) 778-0721; Malaysia (60) 3-36299; Morocco (21) 9-30-6949; Netherlands (31) 70996360; New Zealand (61) 2-662-4295; Norway (47) (02) 559050; Peru (51) (14) 31-8060; Philippines (63) 818-0103; Portugal (351) 1545313; Singapore (65) 271-3163; South Africa (27) 12469221; Spain (34) 14558112; Sweden (46) 8-7617820; Switzerland (41) 17231410, (41) 22360830; Taiwan (86) 2-709-1394; West Germany (49) 89809020.

IBM PC and IBM PC AT are registered trademarks of IBM. Data Translation is a registered trademark of Data Translation, Inc.

IS YOUR HARD DISK FULL?

You thought you would never run out of space on your hard disk, but they fill up quickly. And once your drive has reached its limit, what do you do? Buy an identical drive of the same capacity? Hopefully you'll have room in your computer for an additional drive. If not, do you buy a new drive of greater capacity to replace your old one? Hopefully you'll get a reliable, trouble-free hard disk.

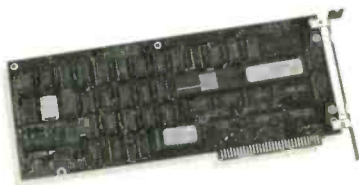

With a PERSTOR 200 Series Controller you can solve today's and tomorrow's hard disk storage problems. PERSTOR 200 Series Controllers use ARLL technology to DOUBLE the capacity of MFM and RLL drives, so whether you have an older drive or you are planning to purchase your first hard disk, you'll get the performance and capacity that you need. For further information write or call (602) 991-5451.

PERSTOR®

Sensible solutions for your hard disk problems.

Perstor Systems, Inc.
7825 East Redfield Road
Scottsdale, Arizona 85260

POWER MEMORY.

Introducing 4x488™

see page 294

You can run your largest programs, control any instrument, test, measure, and print the results. All from one 4x488.

We designed the software, built the board, and wrote the book to increase your productivity.

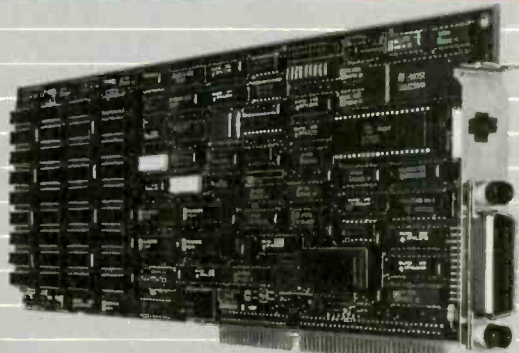

To find out what we can do for you—call 617-273-1818.



Capital Equipment Corp.
Burlington, MA 01803

The bottom line—IEEE-488, RS232, par. port, 4MB EEM LIM, runs DOS and OS/2.

CIARCIA FEEDBACK

In addition, Radio Shack has published a number of books by Forrest Mims; they are all excellent sources of information.—Steve

SB180

Dear Steve:

I'm interested in your articles on the construction of the SB180 computer and its peripheral boards, and I plan to build an SB180 myself. Unfortunately, I cannot afford the Micromint boards, so I will have to either use prototype boards or make my own printed circuit board. In view of the lower electrical quality of these homemade boards, and also to reduce the cost, I plan to use the 3-MHz 64A180 instead of the faster B version that you use. Will I have to change any components besides the processor and the crystal?

I have also been unable to find the FDC9266 floppy disk controller chip. Is there any other combination of more readily available chips that I could use to provide an equivalent interface?

Finally, the SB180FX offers some extra features that I would like to incorporate into my project, if possible. Since I am a relative beginner at electronic construction, I would welcome any advice you can give on the practical details of the construction of the SB180FX.

Jim Hawkins
Royston, England

There shouldn't be any problem with using the 3-MHz version of the HD6 in a home-built version of the SB180. As you suspect, the appropriate crystal should be the only required change; however, you might want to adjust some of the things developed with the 6-MHz unit in mind, such as the disk-access times.

The SMC9266 floppy disk controller chip is compatible with the industry-standard NEC 765A FDC and SMC's 9229 digital-data separator. My main reason for choosing the 9266 was to conserve circuit board space.

Building the SB180FX using point-to-point wiring would be impractical because of the difficulties in wiring the PLCC sockets and the problems associated with the 9-MHz clock speeds.—Steve

Expanding Term-Mite

Dear Steve:

I have some questions about the Term-Mite terminal board (January 1984 Circuit Cellar). I am using mine with an SB180. I've begun working with Echelon's graphics software and I'm looking for information on modifying the Term-Mite program.

continued

Dot, Daisy and Laser.

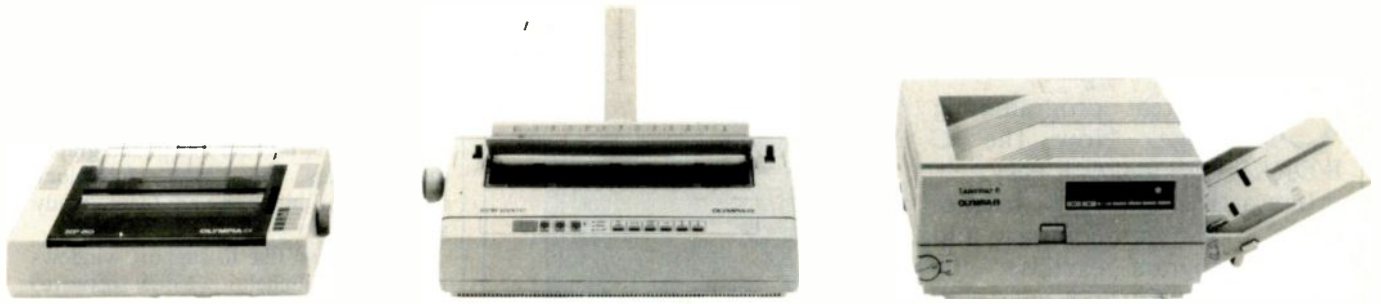

The new family of Olympia printers with a prestigious technological heritage.

Olympia is first in making lasting impressions for a good reason. For over 80 years we've been a leading innovator in typing technology for the office. Now everything has changed. And nothing has changed. Our technology is as new as the dew. Our commitment to reliability, efficiency and service is as solid as ever.

The Olympia dot matrix printers produce clean, crisp printing at

speeds from 130 CPS to 200 CPS for a wide range of applications. And our daisywheels are unsurpassed in printing quality.

Our new Laserstar 6 is compact, versatile, compatible and offers the latest in desktop printing technology.

In short, whatever you need we've got. So don't go shopping without the big new name in printers on your list. Olympia.

We'll make a good impression on you. Then for you.

☎ Call U.S., 1-800-524-2541 (In N.J., 201-722-7000). Or write Olympia U.S.A. Inc., Box 22, Dept. ADV, Somerville, N.J. 08876.

☎ Call Canada, 1-800-268-6464. Or write Olympia Business Machines Canada Ltd., 58 Prince Andrew Place, Don Mills, Ontario M3C 3A2.

OLYMPIA

The Competition

Advanced Engineering from Germany

Easy to C

C is a great programming language. Now the **C WORKSHOP** makes it easy.

Interactive software teaches you C. When you complete and run a program exercise, the amazing Soft Tutor™ gives you immediate feedback, pinpointing any incorrect results.

If you've never programmed before, start with the basic ideas of structured programming. Study what you want when you want, including advanced pointer techniques and linked lists.

The **C WORKSHOP** has everything you need to learn and use C. You can write your own programs, too. The integrated editor and 5500 line/minute compiler are complete with popup menus, customizable keys, online help and C reference lookup.

Let the other guy struggle with confusing books and compilers. Join AT&T and other major



companies now using **C WORKSHOP**. Columnist Adam Green calls it "the most intriguing new type of training system I've ever seen." (InfoWorld, 1/27/86)

Order your **C WORKSHOP** today. And C how easy it is.

Specifications

Package includes tutorial, Soft Tutor, editor, and C compiler. You get unprotected diskettes and coordinated 384-page book.

Tutorial: Quizzes, exercises, electronic index and bookmarks.

Editor: Search and replace, block commands, split screen, context sensitive C help. Creates ASCII files.

Compiler: Full "K&R" C plus signed char, unsigned long, and re-usable member names. Produces 8086 code. Compiles over 5,500 lines per minute (8 MHz AT). Creates .COM programs. Cursor placed at first error message. Library includes disk I/O, cursor control, printf, scanf, longjmp.

Soft Tutor: Detects incorrect output from program exercises. Shows example of the problem. Operates after compiler checks syntax.

Memory usage: Uses 220K. Uses additional RAM as available.

If not satisfied, tell us why and return in 30 days for your money back.

Call toll-free (Visa, MC, AmEx) or write.
 (800) 227-2400 ext. 955.

Name _____
 Address _____
 City _____ Zip _____
 State _____

C Workshop software and book 69.95
 Ship (we use Priority Mail) 5.00
 Sales tax in CA (4.90) \$ _____

Check enclosed for
 Mail to: Wordcraft
 3827 Penniman Ave., Oakland, CA 94619

B309



Quality software since 1981

I already know some of the things I would need: I could start with the source code for the Term-Mite, and then I would need a cross-assembler for the NS-455. Is a cross-assembler available from National Semiconductor, and will it produce code that can be burned into an EPROM?

In addition, I would like to add graphics characters. Can I add a full block and a hashed block, or are they already available?

I would also like to support windowing. With the Echelon window software, you have the ability to read the character at the cursor position and the ability to read a screen page. Are there any hardware limitations on performing either of these operations?

Cortney E. Smith
 Tuba City, AZ

One of my Ask BYTE researchers, Jon Elson, has written a cross-assembler for the NS-455 chip. It's written in Turbo Pascal, which you can run on the SB180. You can reach him at 819 Marshall Ave., Webster Groves, MO 63119, (314) 962-6103.

You can implement the full block and the half-brightness block by displaying a space in reverse video and in half-intensity reverse video. Adding other characters requires the external character-generator feature, which disables half-intensity mode.

Windowing is certainly possible. All scrolling is done by copying character codes from one place in memory to another, and windowing just involves a few checks to keep the cursor in the correct window after linefeeds, wraparounds, and scrolling. When text scrolls off the top (or bottom) of the window, the bytes are just discarded.

The Term-Mite is almost completely software-driven, so you can accomplish almost anything with the right code. The Term-Mite source code is available from Micromint.—Steve ■

Between Circuit Cellar Feedback, personal questions, and Ask BYTE, I receive hundreds of letters each month. As you might have noticed, in Ask BYTE I have listed my own paid staff. We answer many more letters than you see published, and it often takes a lot of research.

If you would like to share your knowledge of microcomputer hardware with other BYTE readers, joining the Circuit Cellar/Ask BYTE staff would give you the opportunity. We're looking for additional researchers to answer letters and gather Circuit Cellar project material.

If you're interested, let us hear from you. Send a short letter describing your areas of interest and qualifications to Steve Ciarcia, P.O. Box 582, Glastonbury, CT 06033.



GRAPHICS TOOLS FOR SOFTWARE DEVELOPERS

What is HALO?

HALO is a device independent library of 190 graphics subroutines. It is compatible with 17 programming languages and over 110 graphics hardware devices for the IBM PC, PS/2 and compatibles. It provides the software designer with the richest environment of graphics functions; the programmer with reliable and well-documented tools; and DP managers with continuity of user interface and database format.

Who uses HALO?

Since its introduction in 1982, HALO has developed an installed base of 60,000+ end-users, hundreds of site-licensed corporations, government agencies, universities, and national laboratories, and most importantly, a family of over 150 Independent Software Vendors (ISVs) who market applications written with HALO.

What about performance?

Our ISVs are the best proof of HALO's performance. They use HALO because:

- building their own library costs too much
- HALO outperforms the rest
- HALO is easier to program
- it supports a wider range of devices for a bigger potential market
- new device drivers are added quarterly to prevent software obsolescence and reduce maintenance costs.



How much does it cost?

A single license for HALO costs \$300.00 and includes all device drivers and your choice of one compiler binding.

HALO is fully documented, includes LearnHALO (an interactive tutorial) and free 800# technical support.

If you need high performance graphics development software that provides a migration path to OS/2 and other future technology, follow the industry leaders—call (800) 426-HALO.

media cybernetics
8484 Georgia Ave.
Silver Spring, MD 20910
(800) 426-HALO
(301) 495-3305 telex 322014

HALO is a registered trademark of Media Cybernetics, Inc. IBM PC, and PS/2 are registered trademarks of International Business Machines Corp.

To get Lotus 1-2-3 to do all this more quickly and easily, we didn't make it more powerful.

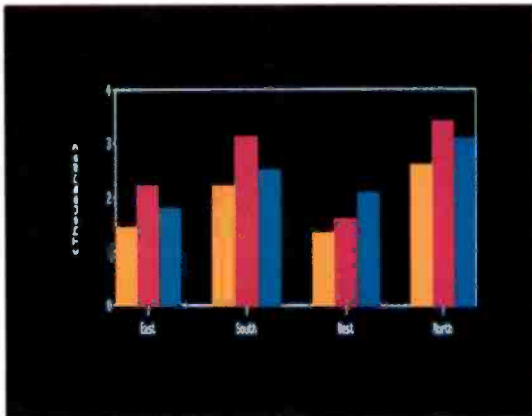

Lotus HAL doesn't change 1-2-3 or the worksheet. It makes things easier. For instance, to graph sales by district from January to March just request "graph Jan to Mar."

	JAN	FEB	MAR	QUARTER
Detroit	1,444	1,589	2,865	5,897
New Orleans	2,234	2,457	3,195	7,886
Boston	1,345	1,480	1,923	4,748
Chicago	4,123	4,535	5,056	14,554
Denver	1,217	1,294	1,812	4,323
Montreal	1,942	2,124	2,777	6,843
Tulsa	2,174	4,226	3,484	9,884
St. Louis	1,284	1,295	1,833	4,412
Dallas	2,143	2,277	3,064	7,484
Atlanta	1,277	1,465	2,26	4,968
Miami	2,244	4,428	3,277	9,949
Tucson	1,799	1,913	2,407	6,119
Seattle	1,799	1,913	2,407	6,119

You can spend a lot of time setting up your spreadsheet. Summing up sales figures is a good example. With Lotus HAL, just request "total all rows" and 1-2-3 and Lotus HAL will create the formulas.

REP NAME	DIST	SALES	PERCENT	LINE	
Miller, Louis	West	\$1,200	8%	Supplies	
Geller, Louis	West	\$14,500	103%	Packaging	
Giles, Louis J.	West	\$3,300	84,000	110%	Supplies

Say you want to extract just the information you want from a database. For example, you want to determine your top sales reps. Simply request "who has sales ≥ 8000."

	January	February	March	Quarter
Detroit	1,444	1,589	2,865	5,897
New Orleans	2,234	2,457	3,195	7,886
Boston	1,345	1,480	1,923	4,748
Chicago	4,123	4,535	5,056	14,554
Denver	1,217	1,294	1,812	4,323
Montreal	1,942	2,124	2,777	6,843
Tulsa	2,174	4,226	3,484	9,884
St. Louis	1,284	1,295	1,833	4,412
Dallas	2,143	2,277	3,064	7,484
Atlanta	1,277	1,465	2,26	4,968
Miami	2,244	4,428	3,277	9,949
Tucson	1,799	1,913	2,407	6,119
Seattle	1,799	1,913	2,407	6,119
Unit Average	2,177	2,395	3,113	7,685

You may find yourself in the position of figuring out how a spreadsheet was built. Well, with Lotus HAL, you simply request "list the relations in the sheet." And away you go.

REP NAME	DIST	SALES	PERCENT	LINE
James, Anna R.	East	\$5,300	\$1,010	18% Food Serv.
Wiley, Linda H.	East	\$9,000	\$9,700	106% Hospital
Casper, Dwight	East	\$7,000	\$7,000	100% Hospital
Trivers, Paul H.	North	\$12,000	\$7,000	58% Packaging
Truman, Albert	North	\$10,000	\$9,000	90% Hospital
Carlson, Kenneth	North	\$3,200	\$1,200	38% Packaging
Wiley, Patrick	North	\$5,000	\$1,000	20% Food Serv.
Sanak, Dia S.	North	\$4,500	\$5,000	111% Hospital
Woodruff, Karen	South	\$13,000	\$6,000	46% Hospital
Swannery, John	South	\$15,000	\$14,000	93% Packaging
Swainson, Jerry	South	\$6,000	\$6,000	100% Food Serv.
Truman, Lisa M.	South	\$9,000	\$7,000	78% Supplies
Harrison, Bart	South	\$21,000	\$21,000	100% Packaging
Johnson, Diane	West	\$7,000	\$7,000	100% Supplies
Abbott, Brian	West	\$7,000	\$7,000	100% Food Serv.
Wynn, Paul L.	West	\$7,000	\$4,000	57% Food Serv.
Wall, Joseph	West	\$4,000	\$3,000	75% Food Serv.
Priddy, Irene	West	\$8,000	\$7,000	88% Supplies

Do you find it hard to sort things by district or sales or any other criteria? Just request "sort by dist."

	January	February	March	Quarter
Detroit	\$977	\$2,254	\$4,509	\$7,741
Tampa	\$723	\$1,706	\$3,493	\$5,922
Justice	\$957	\$2,015	\$4,028	\$6,999
Chicago	\$309	\$1,478	\$2,955	\$4,742
Unit Average	\$787	\$1,873	\$3,747	\$6,407

To create macros, well, you may not believe this. What you see here isn't a description of what's happening—it's the actual macro. See, we told you you wouldn't believe this.

We made you more powerful.



How? With Lotus HAL™—a Companion product for 1-2-3® that helps you take shortcuts, undo mistakes, link spreadsheets, use your own words for commands and basically get more out of 1-2-3 than ever.

So much more, that Computerworld has named Lotus HAL “Product of the Year.”

The screens on the left will give you an idea of how easy it is to get more out of 1-2-3. And these are only a few of the enhancements and new features Lotus HAL brings to 1-2-3.

Lotus HAL gives you the ability to perform 1-2-3 tasks using simple English phrases—called, logically enough, “requests.” This has advantages for all kinds of 1-2-3 users: the newer users will find that difficult tasks are now simplified; the more experienced users will find that many time-consuming tasks can now be performed in a fraction of the time.

In addition to this powerful capability, Lotus HAL also allows you to test assumptions, correct mistakes and simply change your mind with ease. Because through a special capability called “undo,” Lotus HAL lets you reverse your last command—even retrieving a file before saving your work.

Besides all this, Lotus HAL gives 1-2-3 a number of other useful and powerful new features—like spreadsheet auditing and the ability to link cells or ranges between worksheets.

One obvious benefit of all this is that you save time. This is what led Business Software to say, “...(Lotus) HAL gives users the ability to move through 1-2-3 at least twice as fast.”

And what does that savings in time mean to a business person? It means you're more powerful, more productive, more effective than ever before.

Make yourself more powerful, and buy yourself Lotus HAL. You'll find it at your Authorized Lotus Dealer, for just \$150*. Or, you can call us directly at 1-800-345-1043 and ask for Product YS-1377, or ask for YS-1385 to receive more information

about Lotus HAL. See? Everything with Lotus HAL begins with a simple request.

Lotus HAL

Requirements: Lotus HAL is a memory resident program that requires 1-2-3 Release 1A, Release 2, or Release 2.01 for personal computers from IBM, COMPAQ and AT&T, plus 1-2-3 certified compatibles, two disk drives, DOS 2.0 to 3.1, 512K RAM. Please refer to your 1-2-3 package or 1-2-3 documentation for appropriate hardware configurations and DOS requirements or consult your dealer. **Lotus HAL does not operate with 1-2-3 for IBM PCjr, or IBM PC Convertible or Release 1A for the IBM 3270 PC. When you purchase Lotus HAL directly from Lotus, take your first 30 days to try it. If after 30 days, Lotus HAL does not perform as described and you've purchased it directly from Lotus, we'll gladly give you a full refund. © 1987 Lotus Development Corporation. Lotus and 1-2-3 are registered trademarks of Lotus Development Corporation. Lotus HAL is a trademark of Lotus Development Corporation.

*Suggested Retail Price (Plus Sales Tax)

QUBIE' Eliminates the Computer Decision Headache



The best remedy in terms of
Features, Price and Performance is...



\$499

*Shown With Optional 101 Key Keyboard

QUBIE' V20t!!!

Features

- 4.77/8 MHz Switchable Clock
- 135 Watt Power Supply
- 640K Ram On Motherboard
- NEC V20 Processor
- Multi I/O Card
- 360K Floppy Drive
- 'AT' Style Keyboard
- 1 Year Warranty

take one of these and call
us in the morning

Options

Displays

Monochrome Kit (MONOKIT)

Amber Monitor with
Mono Graphic Card
Tilt and Swivel Base

\$149

Color Kit (CGAKIT)

RGB Color Monitor 14" Screen
640 x 200 Resolution
Tilt and Swivel Base
with Color Graphic Adapter

\$399

Enhanced Graphics Kit (EGAKIT)

EGA Hi-Resolution Monitor 14" Screen
640 x 350 Resolution
Fully IBM Enhanced Graphics
Adapter Compatible
Tilt and Swivel Base
Fully Compatible 256K EGA
Card with a Parallel Port

\$579

Drives/Tape Backup

20MB Hard Disk Kit (PC20)

3 1/2 Plated Media Drive
Boots Directly From Drive
IBM Compatible
5 1/4" Short Slot Controller
Card with Cables
Low Power Consumption

\$299

42MB Hard Disk Kit (PC42HH)

AT Speed in a XT
42MB Formatted
5 1/4" Short Slot Controller
Card with Cables
Standard Half Height
Automatic Head Parking
Low Power Consumption

\$519

40MB Streaming Tape Drive

40MB of Formatted Data Per Cartridge
Data Transfer Rate of 1.875MB/Minute
Standard 3 1/2 Floppy Disk Drive Mounting
Uses Standard DC-20000 Tape
Cartridge
Low Power Consumption

\$349

The Qubie' Promise

30 Day No Risk Guarantee

If you are not completely satisfied with your purchase, you may return it within 30 days for a full refund, including the cost to ship it back. (UPS ground shipments only)

One Year Warranty

All Qubie' products carry a full one year warranty on all parts and labor. 48 hour turnaround on all warranty repairs. Extended warranty (PCP) available on all products.

For fastest delivery, send cashiers check, money order, or order by Mastercard/Visa. Personal checks allow 14 days to clear. Corporations and Institutions purchase orders accepted, call for prior authorization. California residents, add 6% sales tax.

QUBIE'

Outside California
(800) 821-4479

Inside California
(805) 987-9741

Technical Support
(805) 482-9829



**"Call Now For
More Selections"**

Inquiry 245 for End-Users.
Inquiry 246 for DEALERS ONLY.

Hours: M - F 8am - 5pm PTZ Sat 8am - 11am

BOOK REVIEWS

CD ROM 2: OPTICAL PUBLISHING

Edited by Suzanne
Ropiequet with John
Einberger and
Bill Zoellick
Microsoft Press
Redmond, WA: 1987
ISBN 1-555615-000-8
384 pages, \$22.95

68000 ASSEMBLY LANGUAGE: TECHNIQUES FOR BUILDING PROGRAMS

Donald Krantz and
James Stanley
Addison-Wesley
Reading, MA: 1986
ISBN 0-201-11659-6
402 pages, \$24.95

SOFTWARE COMPONENTS WITH ADA: STRUCTURES, TOOLS, AND SUBSYSTEMS

Grady Booch
Benjamin/Cummings
Menlo Park, CA: 1987
ISBN 0-8053-0610-2
635 pages, \$35.95

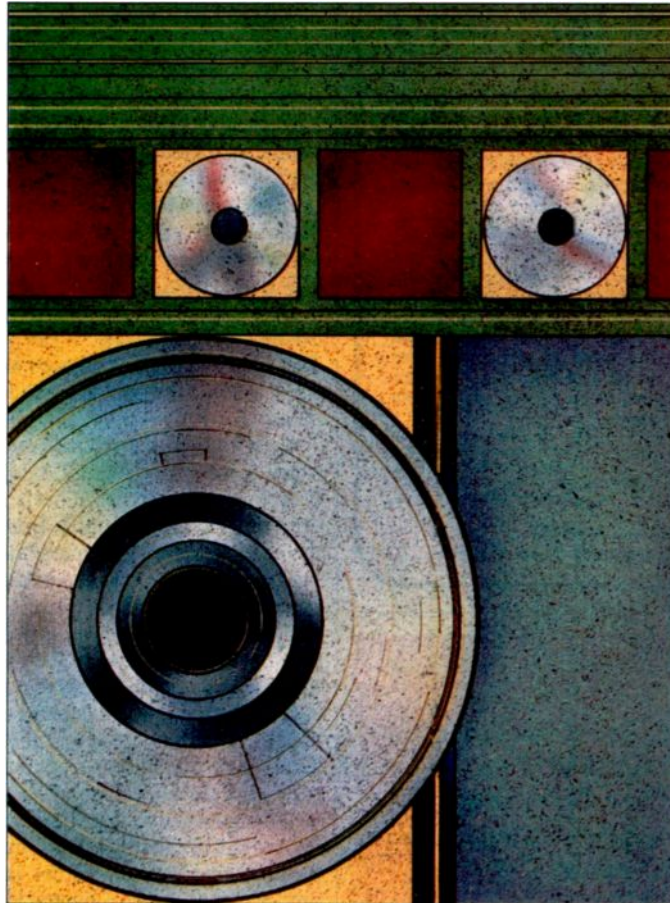

removable data-storage media: They hold far more data, and they are read-only. The difference between a CD-ROM disk and a floppy disk is similar to the difference between a large book and a piece of paper. Like a book, the CD-ROM disk holds phenomenally more data, but it cannot be altered like a piece of paper can.

Optical Publishing treats the process of creating CD-ROM disks like book publishing. Instead of dwelling only on how computers can access CD-ROMs, the book spends a great deal of time explaining how standard computer concepts can be applied to the publishing industry. For example, a CD-ROM disk that has reference material on it is significantly more flexible than a book, even if the book has a great index. However, to be better than a book, the CD-ROM must have software support that's powerful and easy to use.

The book's orientation toward publishing makes it much easier to read than a technical book. It also conveys

CD ROM 2: OPTICAL PUBLISHING

Reviewed by Paul E. Hoffman

Microsoft has long been a champion of emerging technologies, even if it has been a bit late in pushing them out the door. Last year, the company sponsored the first major conference on using compact optical disks (CDs) as read-only memory for computers. Microsoft also published the first major book on the new technology, *CD ROM: The New Papyrus* (reviewed in the October 1986 BYTE).

The articles in the first book covered a wide range of topics and expressed a general enthusiasm for the emerging CD-ROM technology. Many of the articles were introductory in nature and rarely went into much technical depth. The articles in *CD ROM 2: Optical Publishing* are more concrete and assume a greater background in storage concepts.

The articles are written by several different authors and compiled and edited by Suzanne Ropiequet, with assistance from John Einberger and Bill Zoellick. Though it contains many articles, this second volume lacks the variety and quantity of the first volume.

Two features of CD-ROM disks differentiate them from other

the big picture of CD-ROM: The data on the disks will be much more important than the computer controlling the disk reader. Although *The New Papyrus* had more interesting articles on information theory, *Optical Publishing* has more practical advice for people who intend to publish CD-ROM disks.

Responding to Users' Needs

The first couple of chapters quickly cover the background of CD-ROM and describe some of its potential applications. Editors Ropiequet, Einberger, and Zoellick provide an excellent technical summary of how data is read from a CD-ROM disk. Although this information is not necessary for someone preparing a CD-ROM disk, it is useful for an understanding of why you cannot simply give a disk producer a computer tape of files and expect a disk in return.

The next three chapters explain the underlying problems of preparing data for and retrieving information from CD-ROM disks. The editors detail the different methods for putting text on the disk. They also cover a much more interesting issue: how to read the information off the disk. This is followed by a chapter containing much more detail about methods for indexing and retrieving text on a disk, while the next chapter discusses index-

continued

• Z Best Sellers •

Z80 Turbo Modula-2 (1 disk) \$89.95

The best high-level language development system for your Z80-compatible computer. Created by a famous language developer. High performance, with many advanced features; includes editor, compiler, linker, 552 page manual, and more.

Z-COM (5 disks) \$119.00

Easy auto-installation complete Z-System for virtually any Z80 computer presently running CP/M 2.2. In minutes you can be running ZCPR3 and ZRDOS on your machine, enjoying the vast benefits. Includes 80+ utility programs and ZCPR3: The Manual.

Z-Tools (4 disks) \$169.00

A bundle of software tools individually priced at \$260 total. Includes the ZAS Macro Assembler, ZDM debuggers, REVAS4 disassembler, and ITOZ/ZTOI source code converters. HD641-J support.

PUBLIC ZRDOS (1 disk) \$59.50

If you have acquired ZCPR3 for your Z80-compatible system and want to upgrade to full Z-System, all you need is ZRDOS. ZRDOS features elimination of control-C after disk change, public directories, faster execution than CP/M, archive status for easy backup, and more!

DSD (1 disk) \$129.95

The premier debugger for your 8080, Z80, or HD64180 systems. Full screen, with windows for RAM, code listing, registers, and stack. We feature ZCPR3 versions of this professional debugger.

Quick Task (3 disks) \$249.00

Z80/HD64180 multitasking realtime executive for embedded computer applications. Full source code, no run time fees, site license for development. Comparable to systems from \$2000 to \$40,000! Request our free Q-T Demonstration Program.



Echelon, Inc.

885 N. San Antonio Road • Los Altos, CA 94022
415/948-3820 (Order line and tech support) Telex 4931646

Z-System OEM inquiries invited.
Visa/Mastercard accepted. Add \$4.00
shipping/handling in North America, actual
cost elsewhere. Specify disk format.

SUPERIOR PRICE/ PERFORMANCE VERSION

OPC-286, an IBM PC AT*-Compatible,
comes with 12 Expansion Slots
backed up by a 230-Watt Power Supply.

OPC, a leading manufacturer of Computers,
Hard Disk Drives, CRT Display Terminal,
Telecommunication equipments in Korea.

OEMs are Welcome.



* IBM PC-AT is Trade mark of IBM.

OPC Oriental Precision Company Ltd.

HEAD OFFICE

Add. Seoul Office: Geon-Seoul Bldg., 11-12th Fl., 71-2, Nonhyun-dong, Kangnam-gu, Seoul, Korea.
C.P.O. Box 1301 Seoul, Korea, Cable: "PRECISION" Seoul. Tlx: ORANGE K27335
Tel: (02) 510-5114, 549-3674 (Direct) FAX: (02) 549-7679

SUNNYVALE OFFICE

ADD: 1031E DUANE AVE. SUITE A
SUNNYDALE, CA 94086, U.S.A.
TEL: (408) 245-0266
FAX: (408) 737-2635

TOKYO OFFICE

ADD: 2ND, FL., SECOND BLDG. 18-11 KODENMA CHO
NIHONBASHI CHUO-KU, TOKYO, JAPAN
TEL: (813)-661-9317
FAX: 3-661-9209

ing and retrieving in database files.

These chapters make the process sound simple, probably dangerously so. As artificial intelligence researchers are discovering, people expect to see requested information in context. For instance, if a youngster using a CD-ROM for a report in school requested information on George Washington, and the first entry that was shown was about George Washington University, the student might think that the software processing his or her selection was not very smart. Since CD-ROMs can hold an incredible amount of information, the retrieval and indexing software must be more responsive to users' needs.

The material in these chapters presents an unfortunately limited view of the many indexing and retrieval methods that have been developed in the last 20 years. Although a few algorithms are listed, their advantages and shortcomings are glossed over. Important factors such as access times and disk space trade-offs are pretty much ignored, even though these can be explained in terms no more technical than the ones that were used earlier in the book to describe how bits are stored on CD-ROM disks.

Some Comparisons

Two chapters explore images and sound, respectively. The material about storing and processing graphics is much more detailed.

Even though the chapter on presentation systems covers the range in fairly good detail, it offers little guidance in selecting a data format for images. This is unfortunate, since there is a panoply of graphics standards from which to choose. To its credit, the chapter talks about many more side issues of image processing (such as compression, enhancement, and rasterization) than other sources of information.

The coverage of sound unfortunately does not include many side issues. Very little of the information relates to reproducing the audio data on different computers, or even how to store audio information in a general enough fashion for the CD-ROM disk to be of much use on more than one computer. This is indicative of the microcomputer industry's emphasis on visual over aural presentation.

Disk production was largely ignored in *The New Papyrus* but is covered in excellent detail in *Optical Publishing*. Chapter 10 presents an overview of the issues involved with getting data onto the disk, while Chapter 12 goes into the hows and whys of premastering and mastering the disk. These two chapters give the reader a solid idea of the intricacies of preparing data for CD-ROMs.

Thorny Issues

Probably the strongest chapter of *Optical Publishing* is Chapter 13, which covers a wide range of topics under the heading "Data Protection." Many early CD-ROM supporters waxed enthusiastic about putting entire encyclopedias, phone directories, and other reference books on a single CD-ROM, but they forgot a very important fact: The information in these works belongs to different people. This chapter goes into great detail about the legal issues involved in owning information and the format in which it is presented.

The sections on copyrights, trademarks, and trade secrets are also valuable to any print publisher considering putting its works on CD-ROM. Issues such as licensing information and property rights are also covered in detail. This chapter alone is worth the price of the book, especially for people who are wary of new information technologies.

Chapter 14 covers another thorny CD-ROM issue that is often ignored: updating CD-ROMs. Although it does not give many solid recommendations, it does raise interesting market-

continued



Keep your mainframe in touch: Send your remote PCs a card!

If a telephone line goes to wherever your remote PCs are, Sync-Up™ from UDS can now link them directly to your mainframe!

Sync-Up fits a complete synchronous modem and a protocol converter onto a single card; no other modules are required. Add appropriate UDS-supplied software, and you'll have a fast, reliable micro-to-mainframe link. If your system is already supporting 201C, 212A, 208A/B and/or 9600B modems, no modifications are required at the mainframe end.

Sync-Up boards may be specified with software to support 2780/3780 or 3270 BSC, and 3270, 3770 or 5251 SNA or a variety of other protocols. For complete technical data and quantity prices, contact Universal Data Systems, 5000 Bradford Dr., Huntsville, AL 35805. Telephone 205/721-8000; Telex 752602 UDS HTV.

 **Universal Data Systems**



MOTOROLA INC.

Information Systems Group Inquiry 301

AUTOROUTER
NOW AVAILABLE
FOR ADDITIONAL \$995.00

EE DESIGNER™
CAE/CAD Integrated Software Package for
IBM PC, XT or AT **\$995**

At only \$995, no electrical engineer can afford to be without this end-to-end circuit design, simulation and PCB layout tool. You can pay up to 15 times more and still not get all the features offered by EE Designer—Schematic Capture... Circuit Simulation... PCB Layout. 30 day money back guarantee. Full purchase price refunded if not completely satisfied. Call 1-800-553-1177 today to order your package. Bank cards welcome.

VISIONICS
CORPORATION

343 Gibraltar Drive
Sunnyvale, CA 94089

Computerfone™
Interactive Voice Response System

TouchTone In/Voice In/Text In
Voice Out

Excellence
in Voice Quality

- Text-to-Speech
- Digitized Speech
- Synthesized Speech
- Auto Answer/Auto Dial
- Host Independent

Call to hear our demo:
1-904-476-5742

© 1986 Suncoast Systems, Inc. 24 Hrs./7 Days/Wk.

ing questions about the data that is being sold. Such questions should be resolved before you commit to CD-ROM technology.

Real-World Examples

The last two chapters of the book are long, self-aggrandizing case studies about how two companies put together CD-ROM databases from existing microfiche products. The first article is about a card catalog product for libraries. The author reminds us over and over how innovative his company was for using CD-ROM and how wonderful the technology is. Unfortunately, he gives very little concrete information for someone studying the process of transferring information to CD-ROM. The second article, describing a medical information system, is a good summary of the book but presents almost no new information.

If the editors of *Optical Publishing* had included more articles in this section, readers would better understand the problems associated with converting to CD-ROM technology.

One-Sided Coverage

Although *Optical Publishing* covers a great deal of material well, it has some problems. A fair amount of boosterism pervades the articles. Although some of the negative features of CD-ROM are mentioned, they are seriously downplayed. While this book is a very good guide if you're interested in putting out a CD-ROM product, it is not very helpful if you're weighing CD-ROM against other competing technologies.

Part of the reason for this mostly one-sided coverage is probably that *Optical Publishing* is published by Microsoft Press, and Microsoft has invested a great deal of money and time in the CD-ROM effort. Since Microsoft has not backed other technologies (such as write-once optical disks), it is not surprising that alternatives do not get much coverage in the book.

Another reason for the boosterism is that most of the authors work for companies that help other companies produce CD-ROM disks. This could have been avoided by the collection editor, but the lead editor, Suzanne Ropiequet, works for Microsoft Press, and both the other editors work for companies that consult on CD-ROM. While the editors' credentials lend a certain amount of technical credence, they also call their bias into question.

For example, *Optical Publishing* makes dozens of references to the High Sierra Format (HSF) for information on CD-ROMs. In fact, Chapter 11 describes the format in great detail. Other formats are rarely mentioned, and most of the authors manage to put in a plug for HSF. Someone reading the book without reading other articles in the press wouldn't know that there are many other competing formats and that many manufacturers have adopted their own formats.

The emphasis on HSF (also called the HSG Proposal in the book) may be partially due to the fact that Microsoft is a member of the group that is creating the format. Although HSF has a good chance of becoming an accepted standard, the editors of this volume have performed a disservice to readers by not discussing other formats or the reasons why one might choose a nonstandard format.

Optical Publishing contains a wealth of good information and is an excellent companion to *The New Papyrus*. The articles are readable and often interesting. Although the book is flawed by a one-sided attitude toward this emerging technology, it is still worthwhile reading for most people who are interested in CD-ROM technology.

Paul E. Hoffman (2140 Shattuck Ave., Suite 2024, Berkeley, CA 94704) is a freelance writer and consultant. He has written five books about Microsoft products, including Microsoft Word Made Easy (Osborne/McGraw-Hill, 1987).

continued

The new generation of software development tools are here.

Now ...

... It's Your Move



Arity ...

The only fully-integrated family of software development tools designed for today's programming needs.

You're looking for a language which can handle today's programming tasks: expert systems, natural language, relational databases, intelligent human interfaces. Your best move is Arity/Prolog. Arity/Prolog is the foundation for a variety of programming tools designed to meet your programming needs.

Expert Systems

Arity/Expert is a programming tool which bridges the gap between a human's view of a problem and a computer's view of the problem. Arity/Expert is a frame-based system which features backward chaining, automatic explanation generation, positive and negative confidence factors, and complete system debugging facilities. And Arity/Expert is designed with a unique open-ended architecture that allows you to customize your expert system to match your individual needs.

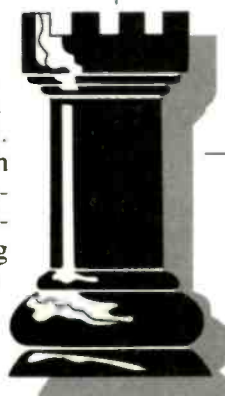

Prolog

Arity/Prolog is a true superset of the Edinburgh Prolog standard. It includes features such as one gigabyte of virtual memory, complete string support, database partitioning, definite clause grammar support, and full MS-DOS access. And Arity/Prolog has highly-developed interfaces to other programming languages, such as C, assembly, and Pascal. So you don't have to abandon your existing development efforts to take advantage of the power and flexibility of Arity/Prolog. Arity/Prolog is the overwhelming choice of users and reviewers alike as the premier Prolog implementation for IBM PCs and compatibles.

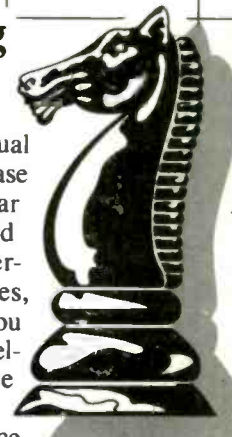

Check us out!

Call today for more information on the Arity family of software development tools.

1-800-PC-Arity
(Mass: 617-371-1243)

SQL

Structured Query Language (SQL) is fast becoming the industry standard relational database interface language. The Arity/SQL package lets you easily add this familiar database interface to your Arity/Prolog applications. Using Arity/SQL queries, you can easily display specific information from a database table, combine data from many different tables, and perform comparisons among data in the database. If you're planning to incorporate relational database technology into any of your applications, you'll want to use the combination of Arity/Prolog and Arity/SQL to speed your development efforts.

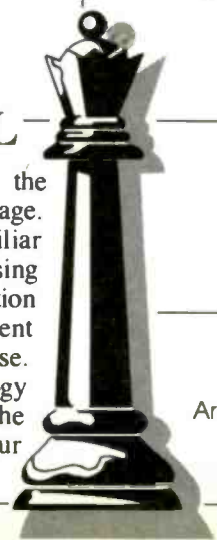

A R I T Y



Arity Corporation 30 Domino Drive
Concord, Massachusetts
01742 Inquiry 238

Introducing

Quaid Analyzer

the tool
that created
CopyWrite

Now you can debug your own programs with a professional quality debugger - the one that unraveled every form of copy-protection used on the PC.

With the Quaid Analyzer, you can:

- See occurrences of any interrupt, with its meaning shown on the screen.
- View memory as text or instructions, scrolling as easily as you do with an editor.
- Run until a memory location or I/O port is changed.
- Protect your hard disk from accidental destruction.
- Analyze software without the source, even when it uses countermeasures to thwart tracing.
- See all stages of the boot load.

We kept the Quaid Analyzer off the market to avoid helping publishers with copy-protection. Now that copy-protection is gone, we can sell it to you.

The Quaid Analyzer is a software tool occupying 100K bytes. It runs on any IBM PC and most MS-DOS systems without hardware modification.



Call (416) 961-8243

Quaid Analyzer \$99 U.S.

All orders shipped at our expense within a day. All major credit cards accepted.

or return coupon to:
45 Charles St. East
Third Floor, Dept. 605
Toronto, Ontario. M4Y 1S2

Payment method MC-Visa-Amex-Diners-Check

Card No. _____

Expiry Date _____

Name _____

Address _____

City/State _____

Phone No. _____

Signature _____



Quaid Software Limited

Ask about Disk Explorer the program that takes over where Quaid Analyzer leaves off.

BOOK REVIEWS

68000 ASSEMBLY LANGUAGE: TECHNIQUES FOR BUILDING PROGRAMS

Reviewed by Adam Brooks Webber

Donald Krantz and James Stanley's *68000 Assembly Language* is a guide to writing programs for the Motorola 68000 family of microprocessors. The many examples included in the text are duplicated on an MS-DOS disk that comes with the book. According to the authors, the book is intended for people who have some experience with assembly language for another microprocessor and who want to make the transition to programming for the 68000. The category of prospective readers could be widened to include anyone who isn't either a 68000 expert or completely new to the concepts of machine-level programming.

Approach

This book is about generic 68000 programming, not about programming for the particular 68000-based computer the authors used. This means that the examples in the book, while helpful, cannot be used without modification on a Macintosh, an Amiga, or an Atari ST.

In general, *68000 Assembly Language* is pleasant to read; the tone is conversational in places. The serious-minded reader may find parts of the book too flip, but I found that the occasional humorous asides helped lighten what would otherwise have been a very dense technical work.

Reference Section

The book has two main sections. The first is a reference manual for the 68000. The authors describe the general architecture of the 68000, including the register set, memory map, and addressing modes. They group the instructions together according to function and explain each one individually. They introduce and compare several common techniques for parameter-passing, including those typically generated by compilers. Finally, Krantz and Stanley discuss the 68000's mechanism for exception handling (but without going into too much detail about the bus protocol).

The authors clearly know what they're talking about and generally have their facts straight, but the editing in the first section of the book is terrible. I found the frequent typographical, factual, and grammatical errors surprising—and what a reviewer finds surprising, an earnest student of the 68000 may find misleading. You may, for example, spend hours looking for another reference to the JNZ instruction mentioned on page 61, only to find no mention of it at all. You may rely on what you're told on page 10, that "When [a data register is] used as a destination, all condition codes excepting the extend flag are affected," which is not always true. To their credit, however, the authors recommend against using their book as a substitute for Motorola's reference manual. I concur.

Tutorial Section

The second section of the book is a 68000 programming tutorial. This is the real meat of the book, based on the very sound idea that people learn to write good code by reading good code. The authors proceed step by step through the development of a multiwindow text editor written completely in 68000 assembly language. They include the entire text of the editor in the book and on the accompanying disk. They provide several other examples in the same spirit: math routines, graphics routines, and a simple device driver. This is a great approach, and the book is worth buying just for the examples. The tutorial accounts for about two-thirds of the book's size and almost all its value.

continued

Inquiry 262 for MS DOS Products.
Inquiry 263 for all others. —

SILICON SPECIALTIES 1-800-354-7330



\$346 With System A or B Only

MIT SYSTEMS TURBO PC/XT

256K Memory, 360K Brand Name Floppy Drive, 135 Watt Power Supply Slide Case, AT Style Keyboard, 4-10MHz Clock Speed, (Keyboard Selectable), 8 Expansion Slots



\$936 With System C or D Only

MIT SYSTEMS PC/AT

↳ 10 MHz Switchable, 512K RAM Expandable to 1MB on Motherboard, a 1.2MB Floppy Drive, 192 Watt Power Supply, Dual Hard Drive & Floppy Controller Card, AT Style Keyboard and clock/calendar with Battery Back-up.

SYSTEM A MIT XT Monochrome System	SYSTEM B MIT XT Color System	SYSTEM C MIT AT Monochrome System	SYSTEM D MIT AT Color System
MIT Turbo XT MIT Monographics Card With Printer Port MIT Amber Monitor With Swivel Tilt Stand MIT I/O Serial/Clock Card MIT 4 Outlet Surge Suppressor	MIT Turbo XT MIT Color Card With Printer Port MIT RGB Color Monitor MIT I/O Serial/Clock Card MIT 4 Outlet Surge Suppressor	MIT 10 MHz AT MIT Monographics Card With Printer Port MIT Amber Monitor With Swivel Tilt Stand MIT AT Multi I/O Card MIT 4 Outlet Surge Suppressor	MIT 10 MHz AT MIT Color Card With Printer Port MIT RGB Color Monitor MIT AT Multi I/O Card MIT 4 Outlet Surge Suppressor
Turbo PC/XT w/640K & 1 Drive with System Order Only \$ 379	Turbo PC/XT w/640K & 1 Drive with System Order Only \$ 456	Turbo PC/XT w/640K & 1 Drive & 20 MG with System Order Only \$ 749	Turbo PC/XT w/640K & 1 Drive, 30 MG with System Order Only \$ 819
PC/AT 8 MHz w/1024K, 1.2 Floppy with System Order Only \$ 980		PC/AT 10 MHz w/1024K, 1.2 Floppy, 40 MG with System Order Only \$1566	

Hardware

Software

PRINTERS		MONITORS	
All Models Call		Alexx Monitors Call	
Brother Printers Call		NEC	
Citizen Printers		Multisync \$ 549	
MSP-10 \$ 269		Other Models Call	
MSP-15 359		Princeton Graphics Monitors Call	
MSP-20 309			
MSP-25 459		COMPUTERS	
Premier 35 445		AST	
1200 169		Model 80 \$1399	
Diablo		Model 120 2099	
D-25 469		Model 140 2449	
635 759		NEC	
Diconics		Multisync 1339	
150 \$ 299		Panasonic	
Epson Printers Call		Business Partner 719	
Hewlett-Packard Call		Sr. Partner 969	
Laser Jet Series II 1829		Exec. Partner Dual Drive 1429	
NEC		Toshiba	
3510, 3550 729		T-1100 Supertwist Call	
8810, 8850 1059		T-3100 Call	
P-6 429		AST	
P-7 619		Six Pack Plus \$ 139	
P-9 429		Other Models Call	
Okidata Call		ATI	
Panasonic		EGA Wonder 245	
1080 I 155		Hercules	
1091 I 169		All Models Call	
1092 I 295		Intel	
1592 375		All Above Boards Call	
1595 419		Paradise	
3131 229		Autoswitch 350 299	
3151 369		Autoswitch 480 355	
Star Micronics Call		5 Pack 99	
Toshiba		Plus Development	
3215L 509		Plus Hard Card 20 Megabyte 609	
341E 665		Quadran	
351 Model II 899		Quad EGA Plus 295	
351 Color 1029		Tecmar	
Qume		All Models Call	
101 Plus Green \$ 315		Video 7	
101 Plus Amber 315		Vega Deluxe 285	
Wise		MODEMS	
30 285		Anchor Automation	
50 359		Anchor Express \$ 185	
75 565		Hayes	
85 425		All Models Call	
Bernoulli Box		Prometheus	
10 Meg \$ 865		1200B w/Software 125	
20 Meg 1199		US Robotics	
40 Meg 1729		Password 1200 149	
Seagate 20 MG w/WD Controller 339		Courier 2400 335	
		Microlink 2400 335	

WORD PROCESSORS		SPREADSHEETS	
Leading Edge Word Processor \$ 25		HAL \$104	
Leading Edge WIP with Spell & Merge 59		Lotus 1-2-3 Ver. 2.01 Call	
Microsoft Word 3.11 75		Multiphan 3.0 108	
Multimate Advantage II Call		Supercalc 4 Call	
PFS: Professional Write 89		Twin 35	
Volkswriter 3 36		VP Planner 47	
Volkswriter Deluxe Plus 59			
Webster New World Writer 65		DATA BASE MANAGEMENT	
Word Perfect (for 4.2) 95		Clipper \$375	
Wordstar w/Tutor 3.31 82		dBase III Plus 379	
Wordstar Pro Pack 4.0 33		db XL 82	
Wordstar 2000 Plus 2.0 209		Eureka 55	
		Paradox 2.0 Call	
		PFS: Professional File 112	
		Revelation 449	
		RBase 5000 System V Call	
		UTILITIES	
MONEY MANAGEMENT		Brooklyn Bridge \$ 75	
Dollars & Sense w/Forecast \$ 92		Carousel 2.0 29	
Tobias Managing Your Money \$111		Disk Optimizer 2.0 29	
		Double DOS 4.0 25	
		Fastback 80	
		Homebase 2.5 40	
		Microsoft Windows 55	
		Norton Utilities 4.0 48	
		Note II Plus Call	
		PC Tools 19	
		Sidexick (Unprotected) 45	
		PROJECT MANAGEMENT	
DESKTOP PUBLISHING		Harvard Total Project Manager II \$282	
Harvard Professional Publisher \$229		Microsoft Project 219	
Newsmaster 48		Super Project Plus Call	
Pagemaker 79		Timeline 2.0 235	
PFS: First Publisher 45			
Ventura Publishing 65		ACCESSORIES	
		Copy II Option Board \$ 75	
		Masterpiece 84	
DISKETTES		Masterpiece Plus 108	
Maxell MD-2 (Qty. 100) \$ 83		Microsoft Mach 10 w/Windows & Mouse 322	
Maxell MD-2HD (Qty. 100) 85		Summasketch 12x12 Tablet 350	
Maxell M25 (Qty. 100) 65			
Sony MD-2 (Qty. 100) 85		LANGUAGES	
Sony 3 1/2 (Qty. 100) 107.50		Basic Compiler (Microsoft) \$219	
Sony 5 1/4 80		C Compiler (Microsoft) 249	
		Cobol Compiler (Microsoft) 385	
		Fortran Compiler (Microsoft) 4.0 245	
		Lattice C Compiler 236	
		Macro Assembler (Microsoft) 83	
		Run C Interpreter 65	
		Ryan McFarlan Fortran 339	
		Ryan McFarlan Cobol 539	
		Pascal Compiler (Microsoft) 165	
		Quick Basic 3.0 55	
		Turbo Basic 55	
		Turbo Jumbo Pack (New Ver.) 159	
		Turbo Pascal w/8087 & BCD 55	
		Turbo Prolog 54	
		Turbo Prolog Toolbox 55	
		Turbo DataBase Tool Box 38	
COMMUNICATIONS			
CompuServe Starter Kit \$ 19			
Crosstalk XVI 88			
Microsoft Access 137			
Mirror II 33			
Remote 88			
Smartcom II 79			
INTEGRATIVE SOFTWARE			
Ability \$ 55			
Enable 2.0 Call			
Framework II 395			
PFS: 1st Choice 82			
Smart Software System 3.1 409			
Symphony 439			
GRAPHICS/MICE			
Harvard Graphics Call			
IMSI Mouse (PC Mouse) w/Dr. Halo II 92			
Microsoft Bus Mouse 6.0 103			
Microsoft Chart 163			
Microsoft Serial Mouse 6.0 115			
PC Bus Mouse (New Ver.) 99			
PC Mouse (New Ver.) 89			

VISA **MasterCard** **NO CHARGE FOR VISA AND MASTERCARD**

- You Pay the Ground Shipping - We Pay the Air
- Ground Shipping & Handling \$6.00
- Free Air Applies ONLY to orders up to 10 lbs. & Over \$50.
- All product carries a manufacturer's warranty. All Guarantees, rebates, mail-order privileges & promotional programs are handled by the manufacturer only.
- Ask for National Accounts
- No APO, FPO, or international orders, please.
- Personal and Company Checks Will Delay Shipping 3 Weeks
- Prices, Terms & Availability Subject to Change Without Notice
- Add 3% for C.O.D. Orders
- Call before submitting P.O.'s
- We Do Not Guarantee Machine Compatibility

Mailing Address: 8804 N. 23rd Avenue/Phoenix, Arizona 85021

- Order Line Hours: Mon-Fri 8:30 a.m.-5:30 p.m., Saturday 9:00 a.m.-1:00 p.m.
- Order Processing: (602) 224-9345 / Mon-Fri 10:00 a.m.-3:00 p.m.



Programmer's Paradise Gives You Superb Selection, Personal Service and Unbeatable Prices!

Welcome to Paradise. The MS/PC-DOS and XENIX software source that caters to your programming needs. Discover the Many Advantages of Paradise...

- Lowest price guaranteed
- Latest versions
- Huge inventory, immediate shipment
- Knowledgeable sales staff
- Special orders
- 30-day money-back guarantee*

We'll Match Any Nationally Advertised Price

New Extended Hours
9AM EST — 7PM EST

Corporate Buyers — Call for special discounts and benefits!

LIST OURS		LIST OURS		LIST OURS	
C++		C UTILITY LIBRARIES		DEBUGGERS	
ADVANTAGE C++	\$ 495 479	ASYNCH MANAGER	175 135	ADVANCED TRACE 86	175 119
PFORCE++	395 225	BASIC-C	175 129	BREAKOUT	125 89
C COMPILERS		BLACKSTAR FUNCTIONS	99 89	C-SPRITE	175 125
AZTEC C-86 COMMERCIAL	499 CALL	C-DISPLAY LIBRARIAN	99 79	CODESMITH 86	145 99
AZTEC C-86 DEVELOPER	299 CALL	CXPEKT	295 249	CSD DEBUGGER	75 59
C86 PLUS	497 369	C FOOD SMORGASBORD	150 95	PERISCOPE I	345 285
C86 PLUS W/ROMPAC	747 549	W-SOURCE	300 179	PERISCOPE II	175 139
DATALIGHT C DEVELOPER'S KIT	99 79	C TOOLS PLUS	175 135	PERISCOPE II-X	145 105
DATALIGHT — OPTIMUM C	139 105	DISPLAY EXPRESS	99 79	PERISCOPE III 8 MHz	995 899
LATTICE C	500 265	ESSENTIAL C UTILITY	185 119	PERISCOPE III 10 MHz	1095 899
W-SOURCE	900 99	ESSENTIAL COMMUNICATIONS	185 125	PFLX 86 PLUS	395 229
LET'S C	75 55	COMMUNICATIONS PLUS	250 189	XVIEW 86	60 49
W-CSD DEBUGGER	150 99	GREENLEAF COMM	185 125	EDITORS	
MARK WILLIAMS C	495 289	GREENLEAF FUNCTIONS	185 125	BRIEF	195 CALL
MICROSOFT C V 5.0	450 269	INTERWORK	129 109	DBRIEF	95 CALL
QUICK C	100 69	LINK & LOCATE	350 315	BRIEF/DBRIEF BUNDLE	285 CALL
TURBO C	100 65	MULTI-C	149 135	C SCREEN	75 CALL
WIZARD C	450 299	MULTI-COMM	149 135	CVUE	75 59
C INTERPRETERS		W-SOURCE	295 225	W-SOURCE	250 199
C-TRIP	300 229	STERYGY DEVELOPMENT TOOLKIT	395 249	EDIX	195 155
INSTANT C	500 379	THE HAMMER	195 129	EMACS	295 265
INTERACTIVE C	249 209	TIMESLICER	295 265	W-SOURCE	995 895
INTRODUCING C	125 105	W-SOURCE	1000 CALL	EPSILON	195 149
RUN/C	120 79	TOPVIEW TOOLBASKET	250 179	FIRSTIME (C)	295 229
RUN/C PROFESSIONAL	250 155	TURBO C TOOLS	129 115	KEDIT	125 89
ASSEMBLERS, LINKERS		SCREEN DISPLAY WINDOWS FOR C		LSE	125 99
ADVANTAGE DISASSEMBLER	295 265	C WORTHY	295 269	PC/EDT	250 229
ADVANTAGE LINK	395 359	CURSES	125 89	PCVI	149 109
ASMLIB	149 129	W-SOURCE	250 169	PMATE	195 115
DIS 'N DATA	165 CALL	FLASH-UP WINDOWS	90 79	SPF/PC	195 145
MACRO ASSEMBLER	150 93	GREENLEAF DATA WINDOWS	225 155	VEDIT PLUS	185 129
PASM 86	195 109	W-SOURCE	395 289	XTC	99 79
PINK 86 PLUS	495 299	MICROSOFT WINDOWS	99 65	SORT UTILITIES	
UNIWARE 68000 X-ASMS	CALL CALL	WINDOWS DEVELOPMENT KIT	395 309	AUTOSORT	150 129
		ON-LINE HELP	149 105	MICROSOFT SORT	195 129
		PANEL	295 199	OPT-TECH SORT	149 109
		PANEL PLUS	495 395	PROFILERS	
		POLYDESK III	99 79	CODE SIFTER	119 89
		POLYDESK ADD ONS	99 79	PFINISH	395 219
		QUICKSCREEN	195 175	THE PROFILER	125 89
		SCREENPLAY (LATTICE)	150 135	LINT	
		SOFTSCREEN HELP	195 169	PC LINT	139 99
		VIEW MANAGER	275 199	PRE-C	295 155
		VITAMIN C	225 165	MAKE UTILITIES	
		VC SCREEN	99 79	ADVANTAGE MAKE	125 99
		WINDOWS FOR C	250 189	LMK	195 139
		WINDOWS FOR DATA	395 315	PMAKER	125 79
		Z VIEW	245 169	POLYMAKE	149 125
		FILE MANAGEMENT		SAPIENS MAKE	79 75
		ASMTREE	395 339		
GRAPHICS		BTREIVE	245 185		
ADVANTAGE GRAPHICS	250 225	XTRIEVE	245 185		
ESSENTIAL GRAPHICS	250 185	REPORT OPTION	145 99		
GRAPHIC	350 285	BTREIVE/N	595 455		
GSS GRAPHICS DEVELOPMENT	495 375	QUICKSCREEN	595 355		
TOOLKIT	CALL CALL	REPORT OPTION/N	345 269		
OTHER GSS	300 205	C-ISAM	225 195		
HALO — ONE LANGUAGE	95 CALL	C-TREE	395 315		
HALO — FIVE MICROSOFT LANGUAGES	595 389	R-TREE	295 239		
METAWINDOW	195 159	C-TREE/R-TREE BUNDLE	650 519		
METAWINDOW PLUS	275 229	CQI	395 329		
METAFONTS	95 CALL	DATAFLX	695 649		
METAFONTS PLUS	275 CALL	DBC III/I	250 169		
TURBO WINDOW/C	95 79	W-SOURCE	500 359		

80386 TOOLS		
ADVANTAGE 386 C	895	805
ADVANTAGE 386 PASCAL	895	805
PHARLAP 386 ASM/LINK	495	395
PHARLAP 386 DOS-EXTENDER	995	845
PHARLAP 386 DEBUG	195	155
PC-MOS/386 1 USER	195	179
5 USERS	595	549

TRANSLATORS BRIDGES		
BASTOC	495	399
DB2C	299	CALL
R BRIDGE	395	339
TP2C	249	CALL

ARTIFICIAL INTELLIGENCE		
ARITY COMBO PACK	1095	979
ARITY PROLOG INTERPRETER	295	229
ARITY STANDARD PROLOG	95	79
CHALCEDONY PROLOG	100	89
GOLDEN COMMON LISP	495	CALL
GCL 286 DEVELOPER	1190	CALL
INSIGHT 2+	485	379
IOCLISP	300	CALL
MICROSOFT LISP	250	155
PC SCHEME	95	85
PROLOG 86 PLUS	250	CALL
SMALTALK V	99	85
TRANS LISP	95	CALL
TRANS LISP PLUS	195	CALL
TURBO PROLOG	100	65
TURBO PROLOG TOOLBOX	100	65
VP EXPERT	100	89

BASIC		
BETTERBASIC	199	129
BETTERTOOLS	95	89
87 QB PAK	180	149
87 SOFTWARE PAK	50	45
EXIM TOOLKIT	99	89
FINALLY	99	89
FINALLY MODULES	99	89
GDPEdit	99	89
INSIDE TRACK	65	55
MACH 2	75	59
MICROSOFT QUICKBASIC	99	65
PEEK'S 'N POKES	45	39
PROFESSIONAL BASIC	99	75
8087 MATH SUPPORT	50	45
PANEL-BASIC	145	115
QUICK PAK	69	59
STAY RES	95	75
TRUE BASIC	150	105
ADD ONS	CALL	CALL
TURBO BASIC	100	65

COBOL COMPILERS/UTILITIES		
COBOL SP11	395	329
FPLIB	149	129
MICRO FOCUS COBOL	CALL	CALL
MICROSOFT COBOL	700	439
MICROSOFT SORT	195	129
MICRO-SORT	175	155
OPT-TECH SORT	149	115
REALIA CICS	995	785

	LIST	OURS
REALIA COBOL	995	785
REALIA MENU	150	119
RM/COBOL	950	649
RM/COBOL 8X	1250	909
SCREENIO	400	CALL
SCREENPLAY	175	129
VISUAL COBOL (MBP)	795	695
FORTRAN COMPILERS UTILITIES		
LAHEY FORTRAN	477	CALL
LAHEY PERSONAL FORTRAN	95	CALL
MICROSOFT FORTRAN	450	269
RM FORTRAN	595	399
ACT-TIMES SERIES	495	389
DIAGRAM'ER	129	115
DOCUMENTER	129	115
87 SFL	250	225
FORLIB	95	85
FORLIB PLUS	70	45
FORLIB SCIENTIFIC SUBROUTINES	295	249
FOR-WINDS	90	69
GRAFLIB	175	169
GRAFMATICS OR PLOTMATICS	135	119
GRAFMATICS AND PLOTMATICS	240	219
IO/PRO	149	129
MATH PAC	495	445
NO LIMIT	129	115
PLOTHI	175	159
PLOTHP	175	159
SSP/PC	350	269
STRINGS AND THINGS	70	49
MODULA-2		
FARBWARE MODULA-2	90	79
LOGITECH MODULA-2		
APPRENTICE PACKAGE	99	79
WARD'S PACKAGE	199	159
MAGIC TOOLKIT	99	79
ROM PACKAGE & RT DEBUGGER	299	239
WINDOW PACKAGE	49	39
REPertoire	89	75
PASCAL COMPILERS		
MARSHAL PASCAL	189	169
MICROSOFT PASCAL	300	185
PASCAL-2	350	329
TURBO PASCAL	100	65
TOOLS FOR TURBO PASCAL		
FIRSTIME	75	59
FLASH-UP NEW	89	79
FLASH-UP TOOLBOX	49	45
METABYTE DATA ACQ. TOOLS	100	89
SCIENCE & ENGINEERING TOOLS	75	69
SCREEN MACHINE	79	75
SCREENPLAY	100	89
SCREEN SCULPTOR	125	95
T-DEBUG PLUS	60	49
TURBO-ASM	100	85
TURBO ASYNCH PLUS	100	79
TURBO DATABASE TOOLBOX	70	45
TURBO EDITOR TOOLBOX	70	45
TURBO EXTENDER	85	65
TURBO GRAPHIX TOOLBOX	70	45
TURBO HALO	129	99
TURBO MAGIC	70	65
TURBO MASTER	125	99
TURBO NUMERICAL METHODS	100	65
TURBO OPTIMIZER	75	65
TURBO PROFESSIONAL	70	49
TURBO POWER TOOLS PLUS	100	79
TURBO POWER UTILITIES	95	79
TURBO REF	50	45
TURBO SMITH	69	45
TURBO TUTOR	40	29
TURBO WINDOW PASCAL	80	69
MANY MORE	CALL	CALL
OTHER LANGUAGES		
IF YOU DON'T SEE IT—CALL!!!!		
ACTOR	495	CALL
APL+PLUS	595	429
JANUS/ADA C PACK	95	89

	LIST	OURS
JANUS/ADA D PACK	900	769
JANUS/ADA ED PACK	395	CALL
LATTICE RPG II COMPILER	750	629
SCREEN DESIGN AID	350	309
SOURCE ENTRY UTILITY	250	199
SORT/MERGE UTILITY	250	199
RPC COMBO	1100	879
PC FORTH	150	109
PC FORTH PLUS	250	199
PERSONAL KEXX	125	99
POCKET APL	95	79
BLAISE		
ASYNCH MANAGER	175	135
C TOOLS PLUS	175	135
EXEC	65	69
PASCAL TOOLS	125	99
PASCAL TOOLS 2	100	79
PASCAL TOOLS & PASCAL TOOLS 2	175	135
RUNOFF	50	45
TURBO ASYNCH PLUS	100	79
TURBO POWER TOOLS PLUS	100	79
VIEW MANAGER	275	199
DBASE COMPILERS, RELATED PRODUCTS		
CLIPPER	695	459
DBC III PLUS	750	595
DBRIEF	95	CALL
FOXBASE	395	CALL
FOXBASE PLUS	395	CALL
GENIFER	395	309
QUICK SILVER	599	499
TOM RETTIG'S LIBRARY	100	79
DIGITAL RESEARCH		
CB 86	600	569
PASCAL MT+	400	379
PLI—86	750	709
DR ASSEMBLER + TOOLS	200	189
ACCESS MANAGER	400	379
DISPLAY MANAGER	500	475
FORTRAN 77	350	329
NEW PRODUCTS		
DATAFLEX —True relational database system that is a powerful, flexible development tool. Includes application generator, relational database manager, on-line multi-file query, forms processing system, on-line multi-key ISAM, macro command language, compiler & text editor.		
List: single:	\$695	Ours \$629
multi-user:	\$1,250	Ours \$1,149
C-XPRT —Expert system development tool for incorporating AI programming capabilities into your C programs. Includes backward & forward chaining, attribute value pairs, frames, inheritance, explanations, why facilities, legal & default values & powerful text features.		
List \$295		Ours \$259
ACTOR —Powerful new language built around object-oriented programming, with windows being defined as objects. Actor makes it easier to include & control windows in application programs.		
List \$495		Ours \$485
QUICK C —Microsoft's reply to Turbo C. Fast and complete; compilation speed of 10,000 lines/min. Includes source-level debugger, graphics libraries, library manager, make facility.		
List \$100		Ours \$69
LATTICE		
LATTICE C COMPILER	500	265
W/SOURCE	900	495
C CROSS REFERENCE GENERATOR	50	39
C FOOD SMORGASBORD	150	95
W/SOURCE	300	179
C-SPRITE	175	125

	LIST	OURS
CURSES	125	89
W/SOURCE	250	169
DBC III/H	250	169
W/SOURCE	500	359
DBC III PLUS	750	595
W/SOURCE	1500	1185
LMK	195	139
SECRETDISK	120	89
SIDETALK	120	89
SSP/PC	350	269
TEXT MANAGEMENT UTILITIES	120	89
TOPVIEW TOOLBASKET	250	179
LIFEBOAT		
ADVANTAGE 386 C	895	845
ADVANTAGE 386 PASCAL	895	845
ADVANTAGE C++	495	479
ADVANTAGE DISASSEMBLER	295	265
ADVANTAGE GRAPHICS	250	225
ADVANTAGE LINK	395	359
ADVANTAGE MAKE	125	99
ADVANTAGE VCM5	350	315
PANEL	295	199
PANEL PLUS	495	395
QUICKSCREEN	295	265
RUN/C PROFESSIONAL	250	155
TIMESLICER	295	265
W/SOURCE	1000	CALL
MICROSOFT		
BUS MOUSE	175	129
C COMPILER	450	269
COBOL	700	439
FORTRAN	450	269
LISP	250	135
MACRO ASSEMBLER	150	93
MUMATH	300	185
PASCAL	300	185
QUICKBASIC	99	65
WINDOWS DEVELOPMENT KIT	195	125
	500	349
PHOENIX		
PASM 86	195	109
PDISK	145	89
PANATASY PAC	995	595
PFINISH	395	219
PFIX 86 PLUS	395	229
PFORCE	395	225
PFORCE++	395	225
PLINK 86 PLUS	495	299
PFMAKER	125	79
PRE-C	195	115
PRE-C	295	145
PTEL	195	115
POLYTRON		
C BEAUTIFIER	49	45
C LIBRARY I	99	85
POLYBOOST	80	69
POLYDESK III	99	85
POLYDESK III ADD ONS	CALL	CALL
POLYLIBRARIAN	99	85
POLYLIBRARIAN II	149	125
POLYMAKE	149	125
POLYSHELL	149	125
POLYXREF	219	189
POLYXREF—ONE LANGUAGE	129	109
POWERCOM	179	149
PVCS PERSONAL	149	125
PVCS CORPORATE	325	315
PVCS NETWORK	1000	CALL
OPERATING SYSTEMS		
OPERATING SYSTEM	99	79
WENDIN TOOLBOX	99	79
PCNY	99	79
PCVMS	99	79
MICROPORT SYSTEM V/AT	549	445
DOS MERGE 286	149	125
RUNTIME SYSTEM	199	149
SOFTWARE DEV. SYSTEM	249	249
TEXT PREPARATION SYSTEM	199	149
UNLIMITED USER UPGRADE	249	249

	LIST	OURS
SCO XENIX SYSTEM V	1295	995
XENIX DEV. SYSTEM	595	499
XENIX OPERATING SYSTEM	595	499
XENIX TEXT PROC. PKG.	195	145
DESKTOP PUBLISHING		
HALO DPE	195	155
XEROX VENTURA PUBLISHER	895	CALL
TURBO VENTURA PUBLISHER	1595	CALL
XENIX/UNIX PRODUCTS		
ADVANTAGE C++	695	CALL
BTRIEVE	595	455
C-TEP	498	379
C-TREE	395	329
DB-VISTA	CALL	CALL
FOXBASE	795	CALL
INFORMIX ESQ/LC	749	599
INFORMIX 4GL	1500	1235
INFORMIX SQL	995	795
LYRIX	595	449
MICROSOFT BASIC COMPILER	695	439
MICROSOFT BASIC INTERPRETER	350	229
MICROSOFT COBOL	995	629
MICROSOFT FORTRAN	695	429
MICROSOFT PASCAL	695	429
NETWORKS FOR XENIX	595	449
PANEL	625	535
REAL TOOLS	149	89
RM/COBOL	1250	949
RM/FORTRAN	750	549
SCO PROFESSIONAL	795	595
UNIXWARE 68020 C CROSS	1390	CALL
TELECOMMUNICATIONS		
ASCUM IV	195	175
PTEL	195	115
SIDETALK	120	89
ADDITIONAL PRODUCTS		
C TOOL SET	95	CALL
COMMAND PLUS	80	69
DAN BRICKLIN'S DEMO PROGRAM	75	59
DISK OPTIMIZER	60	55
FASTBACK	175	135
HELP/CONTROL	125	99
INTERACTIVE EASYFLOW	150	129
LATTICE TEXT MGMT. UTIL.	120	89
MICROSOFT MACH 10		
W/MOUSE & WINDOWS	549	379
MKS TOOLKIT	139	109
NORTON COMMANDER	75	55
NORTON ON-LINE PROG. GUIDE	100	69
NORTON UTILITIES ADVANCED	150	109
NORTON UTILITIES	100	59
PDISK	145	89
SAPIENS V8	300	269
SCREEN MACHINE	79	59
SCROLL & RECALL	69	59
SECURITY LIBRARY	125	115
SOURCE PRINT	97	79
TASKVIEW	80	59
TLIB	100	89
TREE DIAGRAMMER	77	65
FEATURED PRODUCT OF THE MONTH		
ADVANTAGE Graphics —Lightning-fast high-performance C language graphics toolkit. Supports over 30 graphics adaptors. Over 200 functions, including an extensive set for building multi-window applications. Object-oriented concepts provide workstation-like capabilities on your PC/XT/AT—yet no royalties!		
List \$250		Ours \$225

PANEL Plus

Advanced screen manager with a screen designer, code generator and function libraries. Works with popular graphics libraries to allow data entry in graphics modes. Includes **LIFEBOAT** full, portable library source code.

PforCe++

Provides essential tools for object-oriented programming with C++. Speeds development time and ensures cleaner, more maintainable programs. You can build entire systems with a minimum of new coding. Over 400 easy-to-use functions include windowing, database, B-trees, field editing, menus communication, table hashing/parsing, string/file handling and time/date calculations.



Microsoft QuickBASIC

\$20 REBATE

New v. 3.0 high-performance BASIC compiler offers BASICA compatibility plus many enhancements for faster programming: Improved integrated debugging; increased structured and modular programming support; greatly improved math support including in-line 8087/287 code generation; advanced integrated editor; dramatically faster execution speed.



Lattice C Compiler

The latest update of the ideal tool for developing high-performance MS-DOS applications in C. Full implementation of K&R C with UNIX and ANSI extensions. Offers the widest selection of C support tools. Now with Microsoft Windows support.



Terms and Policies
 • We honor MC, VISA, AMERICAN EXPRESS
 No surcharge on credit card or C.O.D. Prepayment by check. New York State residents add applicable sales tax. Shipping and handling \$3.00 per item, sent UPS ground. Rush service available, prevailing rates.
 • Programmer's Paradise will match any current nationally advertised price for the products listed in this ad.
 • Prices and Policies subject to change without notice.
 • New Extended Hours 9AM EST—7PM EST
 *Ask for details. Some manufacturers will not allow returns once disk seals are broken.
Corporate Buyers—Call for special discounts and benefits!

1-800-445-7899
In NY: 914-332-4548
 Customer Service:
914-332-0869
 International Orders:
914-332-4548
Telex: 510-601-7602



42 River Street, Tarrytown, NY 10591





Laptop & IBM PS/2 Users:

The solution to bridge the gap between your 5¼ & 3½ inch drives.

"It's a steal. It allows you to use your favorite DOS shell for selective file transfer and it even lets you use your PC's peripherals from your laptop... In short: An exceptionally fast and functional transfer utility... The Brooklyn Bridge is the perfect solution for people who use a laptop almost exclusively as a portable machine that travels from PC to PC. It's terrific!" — Howard Marks, PC Magazine, July 1987*

Rated as one of the best of the best utilities by John Dvorak.

"This is one of those rare programs that you enjoy the minute you take it out of the box, especially when you discover that a cable is included... Excellent product." — PC Magazine, June 23, 1987*

End users are "sold on Brooklyn Bridge... Dvorak is certainly correct in describing White Crane Systems' Brooklyn Bridge as 'Fabulous'... and I love it." — G. Schochet, Letter to the Editor, PC Magazine, May 12, 1987*

PS/2 users: The Brooklyn Bridge allows data transfer and drive access in either direction so you may also transfer your data back to your 5¼ inch PC.

Priced at \$129.95, call White Crane Systems to order or for more information.

*Reprinted from PC Magazine, copyright 1987 Ziff Communications Company

THE
BROOKLYN
BRIDGE

WHITE CRANE
SYSTEMS

404-394-3119

Suite 151

6889 Peachtree Ind.

Boulevard

Norcross, Georgia

30092

WHITECRANE



On FORM™

COMPLETES PREPRINTED FORMS

Why type it again? Put the data in your databases to work for you. Complete medical insurance claims, financial applications, tax forms and more. With simple instructions, OnForm creates reusable files to describe data to be printed on any form and even allows modifications at run time.

End the drudgery of creating new dBase III programs to complete preprinted forms. At the low price of only \$139.00, OnForm is so inexpensive, it can pay for itself in no time at all. Call Triggs Data Systems, Inc. and take the work out of forms work.

- Selects fields from up to 5 related dBASE III or dBASE III PLUS files to appear on a single form.
- Allows run time entry of data not found in databases.
- Accepts data in character, decimal, integer or date formats.
- Concatenates fields such as name, address, etc.
- Prints single sheets or continuous forms.
- Prints multiple copies of same form without re-entry.
- Creates ASCII text for use with Multimate and most leading word processing packages with merge feature.
- Operates on any IBM compatible micro with 384K RAM, 2 diskette or 1 diskette-hard disk drive.
- Maximum operating speeds with Clipper compiled dBASE III.

1-800-223-1491

In Ohio: 1-800-223-1489



TRIGGS
DATA
SYSTEMS
30311 Clemens Road
Cleveland, OH 44145

Tradenames:
OnForm/Triggs Data Systems, Inc.
dBASE/ Ashton-Tate,
Clipper/Nantucket

BOOK REVIEWS

The examples are not always typical of real-world applications of assembly language. In particular, few circumstances would convince a modern programmer to write an entire screen editor in assembly language. Typically, you might have a few key routines, originally implemented in some other language, that need to be hand-coded for speed. If this is the kind of application you have in mind, you may be disappointed in this book; it doesn't deal with tricks for squeezing every last cycle out of the machine. The examples are not at all sloppy, but they frequently favor readability and the ability to be modified over speed.

The Hardware

The authors' machine is an HSC PRO-68 card running in an IBM PC clone, which explains why the accompanying disk is MS-DOS-compatible. They claim, "We chose this system because it is generic enough so that any software we wrote with the exception of the I/O could be ported easily." Don't believe it. It was certainly a good idea to choose a generic machine just to avoid getting bogged down in the quirks of a big operating system, but there's no chance that the editor would be easy to port to a Macintosh or an Amiga.

In fact, the authors seem to have little or no experience with the popular 68000-based computers. The only area where this has handicapped them is in discussing the properties of different assemblers and linkers. They assume that some of the properties of their assembler (such as automatically optimizing short branches) are typical of all 68000 assemblers. Sadly, this is not the case. It is also not true that all 68000 linkers will handle the 16-bit references on which their examples depend. But these are minor problems; in the large picture, I think it is probably a good thing that the authors didn't opt for a machine-specific approach. The book is about 68000 programming; just keep in mind that you may also need a book on system-level programming for your particular computer.

Starting Point

While *68000 Assembly Language* is not a good 68000 reference and may be too generic to please some owners of 68000-based computers, its extensive, carefully explained examples make it worth reading.

It is clear that you can't learn to speak without hearing speech or to write English without reading it. I believe the same principle applies to the challenge of programming, and *68000 Assembly Language* is a good place to start.

Adam Brooks Webber is a software engineer at True BASIC Inc. (39 South Main St., Hanover, NH 03755).

SOFTWARE COMPONENTS WITH ADA: STRUCTURES, TOOLS, AND SUBSYSTEMS

Reviewed by Douglas Arndt

The cornerstone of software engineering is the concept of a disciplined approach to building ever-larger software systems. This means reusing software components that have been thoroughly tested and whose interfaces are well defined. Identifying and implementing these modular components is the subject of Grady Booch's latest work, *Software Components with Ada*.

Grady Booch is considered a pioneer within the Ada community. He lectures at Ada and software-engineering conferences, and he speaks from a great deal of experience. He is part of the original team that built the Rational Corp.'s software development environment—more than a million and a half lines of Ada

continued

AW...

WHAT THE HECK!

ProDesign II — Still \$299!

ProDesign II — the Easy-to-Use CAD System. The CAD system that was introduced two years ago for the amazingly low price of \$299. The CAD system that has undergone four major revisions with more than 400 enhancements. The CAD system that still costs only \$299!

How do we do it? Our accountants said to raise the price to cover research and development costs. Our business advisors said to charge more for the additional features. Our competitors said it's impossible to stay in business selling a comprehensive CAD package such as ProDesign II for only \$299.

And our customers said \$299 is great. So, we said:

"Aw... What the Heck! \$299 it is!"

Now, two years after its introduction, ProDesign II is one of the world's leading CAD packages. It has features previously found only on CAD systems costing thousands of dollars. For the single price of \$299, you get these features and more:

- Support for more than 180 printers (including color printers)
- Support for more than 80 plotters, with plotter optimization.
- Easy-to-Use single keystroke commands.

- On-screen menus accessible with a mouse.
- Comprehensive drawing commands, including the finest curve fitting in the industry.
- Editing features unsurpassed by ANY other CAD package.
- Extensive snap features, including snap to point, endpoint, midpoint, line, circle, ellipse, arc, intersection, and perpendicular.
- True Auto Dimensioning with several formats.
- Extensive Layering features.
- Full Macro capabilities.
- Specialized drawing aids, such as tangents to circles and ellipses, parallel lines, parallel curves, wide lines, and more.
- Complete hatching with up to 40 different patterns.
- Area and length calculation for line curves, circles, etc.
- Full Zoom, Pan, and Rotate capabilities.
- Capability to transfer drawings to and from other programs.
- Capability to Break/Trim Lines, Curves, Circles, Arcs, and Ellipses.
- Many more features — *All for only \$299!*

Where do you get ProDesign II? See your local computer dealer, or contact:

American Small Business Computers, Inc.
118 South Mill Street
Pryor, OK 74361
(918) 825-4844

Telex 9102400302

Inquiry 17

Want more information? Call or write for a detailed brochure and a free demo disk!

PRODESIGN II STILL ONLY \$299!

F-18 HORNET

DRAWN USING PRODESIGN II

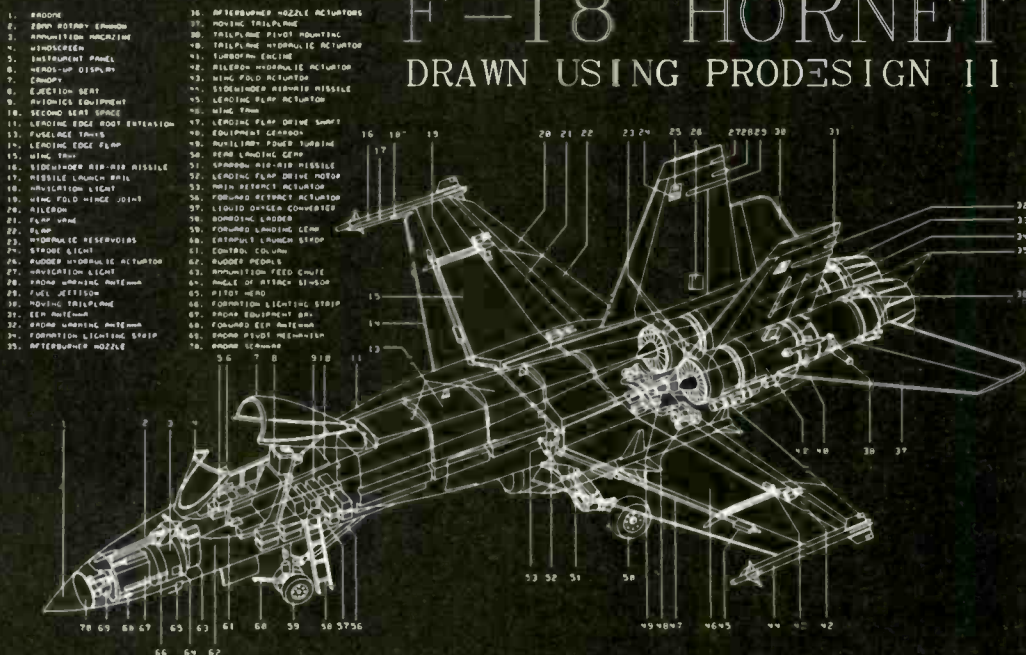

AT LAST: Professional Typesetting Capability For PC Users

With **PC_TEXTM** — the best-selling full implementation of Professor Don Knuth's revolutionary typesetting program **TEX**.

FINEST Typeset Quality Printing From:
dot matrix laser phototypesetter

$$\sum_{i=1}^{\infty} \frac{1}{i} \begin{pmatrix} a_{11} & \dots & a_{1n} \\ a_{21} & \dots & a_{2n} \\ \vdots & \ddots & \vdots \\ a_{m1} & \dots & a_{mn} \end{pmatrix} \int_{-\infty}^{\infty} e^{-x^2} dx$$

WIDEST Range Of Output Device Drivers:

- Epson FX, LQ
- HP LaserJet*
- Toshiba
- Apple LaserWriter
- Corona LP-300*
- APS-5 phototypesetter
- Screen preview, with EGA or Hercules card

MOST COMPLETE Product Offering:

PC_TEX (not copy protected) includes the following:

- Our specially written *PC_TEX Manual*, which enables you to start using **TEX** right away.
- Custom "macro packages" that provide formats for letters, manuals, technical documents, etc.
- The **L_ATEX** document preparation system, a full-featured macro package for preparing articles, books, reports, etc., and **L_ATEX User's Manual**.
- **A_MS-TEX**, developed by the *Amer. Math. Society* for professional mathematical typesetting.

Site licenses, volume discounts, and interfaces to PC Paintbrush, PC Palette, FancyFont and Fontrix are also available.

PRICED FROM ONLY \$249.00!

(Printer drivers and interfaces additional.)

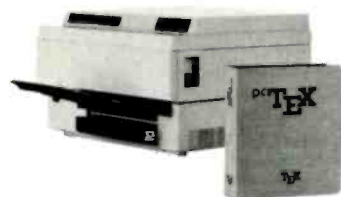

Laser printer,
fonts & software
from \$2995.00

For IBM PC/XT, AT or compatible, DOS 2.0 or higher, and 512K RAM. Hard disk required for printer drivers and fonts.
*HP LaserJet and Corona require additional interface boards.

For more information call or write:

Personal TEX, Inc.

12 Madrona Avenue, Mill Valley, CA 94941 (415) 388-8853

This ad, with space for the photograph, produced by PC_TEX. Typeset on the Epson FX80, the Corona LP-300 laser printer, and the Autologic APS-5 phototypesetter.

TEX is a trademark of the American Mathematical Society. Manufacturers' product names are trademarks of individual manufacturers.

BOOK REVIEWS

code, including a virtual-memory operating system. *Software Components with Ada* is a compendium of lessons learned over the past several years.

Software Reusability

Software Components with Ada is organized into four "packages" (the term is derived from an Ada feature that enforces encapsulation). Each package is segmented into chapters. The first package introduces such concepts as reusability, object-oriented development, and the characteristics of structures, tools, and subsystems. Booch describes how the application of these concepts is a superior approach to building software systems.

The theme of software reusability recurs throughout the book. Booch cites studies that conclude that only 15 percent of the code written on the average software project is "new." The rest has been written before, in some form or another, and could be reused. Hardware manufacturers have achieved orders of magnitude increases in productivity by adopting the component approach to engineering; software developers are just now beginning to catch up out of necessity.

In the first package, Booch reaches the conclusion that families of software components are necessary for the same reason that hardware vendors make many versions of the same micro-processor that vary according to power requirements, clock speed, price, and so on. Accordingly, he introduces a taxonomy he has developed to specify the various forms software components can take. The taxonomy separates components into data structures, tools, and subsystems. From there, the forms branch out until the lowest-level components are identified.

Data Structures Examined

In the second package, Booch explores the design and implementation of data structures. This section transcends other books on the subject because it takes the discussion of time and space behavior much further.

Each chapter in the second package describes a different data structure or class of structures. Still, the chapters are organized so that issues such as privacy, consistency, and concurrency can be isolated and examined.

In the third package, Booch shows how data structures are used to construct higher-level components that he categorizes as tools. In his taxonomy, tools are divided into the categories of utilities, sorting, searching (including pattern matching), and pipes and filters. Utilities are further separated into primitive, structure, and resource utilities. Booch designs and implements several examples.

Subsystems and the Law

The fourth package is split into two chapters. The first concerns subsystems, which reside at the highest level of abstraction of software components. Booch describes the subsystem concept, along with its rationale and several technical and managerial issues. He cites several examples of applications at the subsystem level, including a windowing feature for user interfaces and the Space Shuttle Orbiter's flight computer operating system.

The last chapter, "Managerial, Legal, and Social Issues," covers such topics as how to identify reusable components, the techniques and problems associated with maintaining a large library of components, and how actual reuse affects the entire software development life cycle. Booch then moves on to the legal aspects of reuse.

Thorough and Applicable

In addition to being informative, *Software Components with Ada* is enjoyable to read. It is well-organized and written in a

continued

0000: 1978 74 72 69 68 65 28 61 6E-79 28 68 65 79 8D 8A 24 strike any key...
 0000: 1988 58 88 FF FF 3E C8 BB 8E-88 26 8A 87 3C 88 75 63 PB...: .C.uc
 0000: 1998 BC C8 BE C0 E4 67 88 81-74 8C 2E C8 86 5F 86 88 .H.Pdg(t..F...



USING THE WRONG LANGUAGE CAN BE MURDER. SPEAK SMALLTALK/V.



Let's talk languages. Programming languages like Turbo Pascal, C or Basic can be killers. To many, they're foreign, complex, and generally intimidating. Mistakes can be deadly.

With Smalltalk/V, you have an elegantly simple solution that puts the power and majesty of

a major AI programming language on your PC or compatible. It makes no difference if you're an experienced programmer or just getting started. Smalltalk/V gives you an easy-to-use and flexible programming tool.

This is the same language used by leading software companies for their new product development. There are sound reasons for this. Smalltalk/V offers a totally integrated programming environment using the premier object-oriented language. You use natural language rather than complex programming codes. It puts Macintosh-type graphic features on a PC including overlapping windows, bit-mapping, pop-up menus, and a mouse interface. More than mere window dressing, Smalltalk/V delivers fully interactive windows that are easy to build and quick to modify.

But don't just take our word on it. Hear what the experts have to say:

"This is the real thing folks. A super Smalltalk like this turns your PC into a hot workstation. It's fantastic... Highly recommended."

John Dvorak
Contributing Editor
PC Magazine

"The tutorial provides the best introduction to Smalltalk available."

Dr. Andrew Bernat
AI Expert Magazine

"Smalltalk/V is the highest performance object-oriented programming system available for PCs."

Dr. Piero Scaruffi
Chief Scientist
Olivetti Artificial
Intelligence Center

Today, thousands of professionals, scientists and engineers are using Smalltalk/V to solve both simple and expert problems. Giving them a new dimension in computer applications for their PC.

Put new life into your PC by calling toll free 1-800-922-8255 and ordering Smalltalk/V today. Smalltalk/V by Digitalk, Inc., 9841 Airport Blvd., Los Angeles, CA 90045. (213) 645-1082.

\$99.95

Smalltalk/V comes with 10 starter applications including Prolog and each Application Pack adds several more. All source code is included. Supports 640 x 480 color graphics with color extension pack.

Smalltalk/V requires DOS and 512K RAM on IBM PC/AT/PS or compatibles and a CGA, EGA, Toshiba T3100, Hercules, or AT&T 6300 graphic controller. A Microsoft or compatible mouse is recommended. Not copy protected.

Turbo Pascal is a trademark of Borland International. IBM, IBM PC/AT/PS are trademarks of International Business Machines Corporation. Macintosh is a trademark of Apple Computer, Inc.

TO ORDER CALL 1-800-922-8255 TODAY.

60-DAY MONEY-BACK GUARANTEE*
 Send check, money order, or credit card information to: Digitalk, Inc., 9841 Airport Boulevard, Los Angeles, CA 90045.
 Credit Card VISA Mastercard
 Card number: _____
 Expiration date: _____
 Name: _____
 Street Address: _____
 City/State/Zip: _____

Smalltalk/V \$99.95
 RS-232 Communications Application Pack \$49.95
 EGA/VGA Color Extension Pack \$49.95
 "Goodies" Application Pack \$49.95

SPECIAL OFFER:
 Smalltalk/V and all 3 packs only \$199.95
 Shipping and handling (Outside North America) \$15.00

California residents add applicable sales tax
TOTAL \$ _____

*Unconditional 60-day money-back guarantee. Simply return to Digitalk, Inc. and your refund will be immediately forwarded to you.

Smalltalk/V
 digitalk inc.

SAVE TIME with FORMATTED DISKS

"Ready to use in your
IBM PC or compatible."

 **Nashua**™

labeled or unlabeled,
your choice 53¢.

3M

unlabeled only, 69¢.



ALF formats brand-name factory certified bulk-pack disks and double-checks them for defects. You save the time and hassle of formatting disks yourself.

CALL TODAY TOLL FREE

1-800-321-4668

in Colorado, 303-234-0871

Hours: 8:00-5:30 Mountain Time, Monday-Friday
Prices do not include shipping, and are subject to change.

ALF 1315-F Nelson St. Denver, CO 80215

Expansion Chassis/Tape Back-up

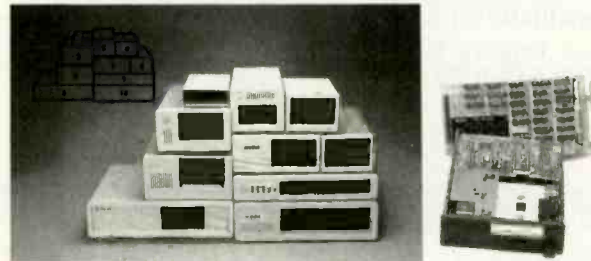

Specification

Model No.	No. of Slot	Space for 1/2 Height Drive	Power Supply (Watts)	Dimension D×W×H(cm)	Price
M-1*	0	1	50	30×15×6.5	\$139
M-2	3	3	100	42×25×16	\$299
M-3	5	3	100	39×30×15	\$239
M-4	12	2	100	40×49×14	\$299
M-5	0	2	45	39×18×15	\$149
M-6	0	1	50	26.5×18×13.5	\$169
M-7	5	2	100	38.5×30×13.5	\$299
M-8	0	2	45	39.5×18×13.5	\$149
M-9	0	2	60	38.5×49×9	\$249
M-10	8	4	135	43×49×14	\$239

* Extra space for a stand alone controller

EXT and RCV Adapters (Interfacing Computer & Chassis With Slots)...\$149

Tape Back-up (With Controller & Cable)...\$499

ORDER TOLL FREE: (800) 826-0267
In California Call (408) 434-0877

SOURCE ELECTRONICS CORP.

2380 Qume Drive, Suite E

San Jose, CA 95131

Telex: 279366

Fax: (408) 434-0539

relaxed, first-person-plural style. Booch makes appropriate and frequent use of pictograms to illustrate concepts and then follows up with fully coded examples. The book's 8½- by 11-inch format lets the code be spread across fewer pages. Each chapter concludes with a summary, a list of references, and a series of exercises for the reader.

Booch does not assume that the reader is familiar with data-structure theory. He patiently examines the motivation for each abstraction, usually associating each one with some model of reality. This approach increases the book's appeal as a textbook for classes in data structures, object-oriented design, or software engineering techniques.

Ada's Union with Design

Software Components with Ada is both a companion and a successor to Booch's influential first book, *Software Engineering with Ada* (Benjamin/Cummings, 1983, second edition 1986).

The connection between software components and Ada in both books is not just coincidental. Booch deftly describes the comfortable marriage between Ada and object-oriented design. While the concept of software components could be applied to most high-order languages, Ada was specifically designed to support the component paradigm. Ada offers the package structure, generics, separate compilation, a built-in tasking model, and a tightly controlled language definition (no subsets or supersets)—a nearly ideal combination for implementing reusable components.

Two Shortfalls

I have two significant concerns about the book's contents. The first is the issue of efficiency. Booch does not discuss the relative merits of iterative versus recursive operations on, for example, search operations or insertions into tree structures. He consistently chooses the recursive method because of its elegance and ease of implementation. Although both algorithms are linearithmic in nature, there is a significant penalty on most computer architectures for using the recursive method of insertion and lookup. The fact that Booch's methodology doesn't provide us with a way to differentiate between two algorithms that have similar or identical time behavior but different levels of efficiency is a problem that should be addressed.

The other thing that bothers me is that Booch seems to avoid the problem of handling limited private types (i.e., types for which no assignment operator is implicitly provided). Many of the structures in the book import only private types (for which assignment is implicit) as generic parameters but export limited types, creating incompatible interfaces. You can't have a queue of stacks, for instance, because the stack type is limited, and the queue package won't work with limited types. If you want a structure of some limited type, you must manage an access (pointer) type, adding a level of indirection and a lot of garbage-collection headaches. This approach is fine in small examples, but it is insufficient in large, complex systems. Booch acknowledges that this is a problem but offers no general solution.

A Software Component Standard

In the final analysis, these concerns do not diminish the impact the book should have on the software community. Booch pulls together many of the threads of traditional software theory and weaves them into a fabric that is altogether unique. I believe *Software Components with Ada* is destined to take its place on the reference shelf with the standard works of computer science. ■

Douglas Arndt (9427 East Third St., Tucson, AZ 85710) is a senior software engineer at Dalmo Victor and Singer. He is active in the Association of Computing Machinery's Special Interest Group on the Ada Programming Language (ACM SIGAda).

24 Hours A Day, 7 Days A Week

SOFTLINE

NEVER SLEEPS

FOR THE BEST BUYS, CALL US ANYTIME.

Software

Word Processing/ Desktop Publishing

Fancy Font	\$ 139
Microsoft Word 3.1	\$ 209
Multimate Advantage-II	\$ 259
Lotus Manuscript	\$ 359
Office Writer /Speller	\$ 249
Pagemaker	\$ 499
PFS: Prof Write	\$ 119
Ventura Publisher	\$ 519
Volkswriter 3	\$ 145
Word Perfect 4.2	\$ 195
Word Perfect Server	\$ 309
Word Perfect Station	\$ 75
Wordstar Pro 4.0	\$ 249
Wordstar 2000 +	\$ 289
Xywrite III	\$ 199
Xywrite III +	\$ 249

Database Systems

Clipper	\$ 389
DBase III Plus	\$ 399
DBase III Lan Pak	\$ 599
Foxbase +	\$ 229
Paradox 2	\$ 429
PFS: Prof File	\$ 145
Q&A	\$ 219
R Base System V	\$ 449
RapidFile	\$ 239
Reflex	\$ 89

Spreadsheets/ Integrated Packages

Enable 2.0	\$ 389
Framework II	\$ 399
Javelin +	\$ Call
Lotus 1-2-3	\$ 309
Lotus Hal	\$ 109
Multiplan	\$ 125
Smart System	\$ 429
SuperCalc 4	\$ 279
Symphony	\$ 449

Communications

Carbon Copy +	\$ 119
Crosstalk XVI	\$ 99
Crosstalk Mark IV	\$ 129
Relay Gold	\$ 159
Smarterm (Persoft)	\$ Call
Smartcom II	\$ 99

Statistics

SPSS/PC +	\$ 699
Statgraphics	\$ 419
Systat	\$ 439

Graphics

Chartmaster	\$ 209
Diagraph	\$ 279
Diagram Master	\$ 189
Freelance Plus	\$ 349
Graphwriter Combo	\$ 349
Harvard Presentation Graphics	\$ 249
MapMaster	\$ 219
MS Chart	\$ 189
PC Paintbrush Plus	\$ 109
Picture Perfect	\$ 209
Prodesign II	\$ 159
Publishers Paintbrush	\$ 219
Signmaster	\$ 139

Desktop Environments

Lotus Metro	\$ 65
MS Windows	\$ 65
Sidekick	\$ 59

Project Management

Harvard Total Project Manager II	\$ 369
Microsoft Project	\$ 249
Superproject Plus	\$ 299
Timeline 2.0	\$ 259

Languages/Utilities

Fastback	\$ 89
Lattice C	\$ 219
Norton Advanced	\$ 89
Microsoft C	\$ 279
Mace Utilities	\$ 65
MS Fortran 4.0	\$ 279
Quick Basic	\$ 69
Turbo Basic	\$ 59
Turbo C	\$ 59
Turbo Pascal	\$ 69

Productivity Tools

VP Expert	\$ 59
Eureka	\$ 69
Sideways	\$ 39

Accounting

BPI	\$ 179
Great Plains	\$ 499
Easy Business	\$ 359

QUALIFIED INSTALLERS
AVAILABLE

Hardware*

Computers

AST Premium 286	\$ Call
Wyse 286 PC	\$ Call
Panasonic Business Partner	\$ Call
Toshiba 3100/1100 +	\$ Call

Multifunction Boards

AST Advantage (128K)	\$ 319
AST Advantage Premium	\$ 419
AST 6 Pak Plus (64K)	\$ 119
AST I/O Mini II	\$ 119
AST Premium (256K)	\$ 219
AST Rampage PC	\$ 279
AST Rampage 286	\$ 399
Inboard 386AT	\$1350
Intel AboveBoard	\$ Call
Orchid Jet 386	\$ 949
PC Turbo 286 (1MB)	\$ 749
PC Tiny Turbo 286	\$ 449
QuadBoard (0K)	\$ 109

Display Boards

ATI EGA Wonder + Hercules Graphics Card Plus	\$ 239
Hercules Color Card	\$ 189
Hercules Color Card Hercules In-Color Card	\$ 159
NEC GB1	\$ 309
Paradise Auto Switch EGA 480	\$ 359
Quad EGA Prosync	\$ 399
Quadram EGA + Tseng EVA 480	\$ 339
	\$ 289
	\$ 389

Modems

Hayes 1200	\$ 299
Hayes 1200B	\$ 299
Hayes 2400	\$ 499
Hayes 2400B	\$ 449
Migent Pocket	\$ 159
US Robotics 1200	\$ 139
US Robotics 1200B	\$ 109
US Robotics 2400B	\$ 189
Ventel 2400	\$ 409
Ventel 2400B	\$ 409
Watson	\$ 339

Emulation Boards

AST 5211-11 + Irma/2	\$ 629
	\$ 725

Monitors

Amdek 310A	\$ 149
Amdek 410A	\$ 169
Amdek 1280	\$ 779
NEC MultiSync	\$ 579
Princeton HX-12	\$ 439
Princeton MAX-12E	\$ 149

Printers/Plotters

Epson EX-1000	\$ 549
Epson FX-86E	\$ 359
Epson FX-286E	\$ 499
Epson LQ-1000	\$ 569
HP 7475A	\$1499
HP Laserjet II	\$1825
NEC 3550	\$ 789
Okidata 192 +	\$ 379
Okidata 193 +	\$ 549
Okidata 292	\$ 539
Okidata 293	\$ 689
Toshiba P321	\$ 549
Toshiba P341 E	\$ 769
Toshiba P351 Model 2	\$ 999

Mass Storage/Backup

I/Omega 20 + 20 W/intfc	\$1949
Irwin Tape Drives	\$ Call
Plus HardCard 20MB	\$ 675
Plus HardCard 40	\$ 949
Priam 42MB AT	\$ 799
Priam 60MB AT	\$ 899
Seagate ST 225 W/int	\$ 329
Seagate ST238 W/int	\$ 389
Tallgrass	\$ Call
Tecmar QT60 Int	\$ 899

Networks

ArcNet	\$ CALL
Novell	\$ CALL

Input Devices

Keytronics 5151	\$ 169
Keytronics 101	\$ 119
Microsoft Mouse	\$ 129
PC Mouse/Dr Halo II	\$ 109

Accessories

Curtis Ruby	\$ 59
DataShield S-100	\$ 69
Logical Connection	\$ 329
Masterpiece Plus	\$ 129
Microfazer II	\$ 269
80287 Math Chip	\$ 189

3.5 INCH SOFTWARE NOW IN STOCK CALL !!

24 Hours A Day, 7 Days A Week

1-800-221-1260

Customer Service Hours: 9 AM — 5 PM, Mon. — Fri.
In New York State call (718) 438-6057

FREE SHIPPING

on all orders over \$1,000.00, credit card orders and prepaid orders.



Our Policy:
• All returns require prior authorization • Visa or MasterCard—add 3% • Cash, M.O. or bank check only—add \$5.00 per order • Prepaid personal or company check—allow two weeks to clear
• Shipping via UPS surface—add \$3.00 per item, UPS Blue—add \$8.00 per item • Call for shipping costs. • Prices subject to change; call for latest prices.

Softline
P.O. Box 300729,
Brooklyn, NY 11230
TELEX: 627-30170 or 910-240-3918
FAX: 718-972-8346

The most powerful

Just because Freeway is easy to use, doesn't mean it's weak. Freeway is communication software by and for the power user.

Automation: You shouldn't waste your time with simple chores. So Freeway automates your communication. It stores over 20 settings for each host you call in its Phonebook. If a number is busy, Freeway will redial until you get through. And, in addition to the Autopilot, Freeway includes a powerful script facility, with access to all Freeway's features. For instance, a script can wait until 2 a.m., call a BBS, check for mail, and download any new files, leaving you an exact transcript.



Control: Freeway gives you far more detailed control than just the usual baud rate and parity. You have seven filters for incoming and outgoing text. You can specify the characters used for flow control, and the length of a Break. In all, you have control of over 50 settings, most of which can be different for each phone number.

And remember, just because Freeway is powerful, doesn't mean it's difficult. The advanced features are as accessible as the basics, via fast menus with keyboard shortcuts.

FREEWAY™ is the best commu

The easiest to use

Take Freeway's simple menus and clear displays. Add the arrow keys and the Escape and Enter keys. The result is powerful but straightforward communication — at your fingertips.

- 1 **Phonebooks:** Freeway lets you store the phone numbers (and other settings) for up to 100 computer systems. You just use the arrow keys to pick the number you want, hit Enter, and leave the dialing to us.
- 2 **Autopilot:** Computer communication is more than just placing a call. You have to log on to the other computer, and often type introductory commands. Freeway provides an "autopilot" to relieve you of this chore. You simply go through these preliminaries once, with the autopilot noting your every move. Then, when you next call, the autopilot will do the work for you.
- 3 **Setting Up:** Setting up Freeway is a piece of cake! The parameters you need — baud rate, parity, and even the number to call — are gathered in simple menus. To set them, you just zip through with arrows and Enter, and then save them in the Phonebook. Later, changing one or all of them is just as easy!

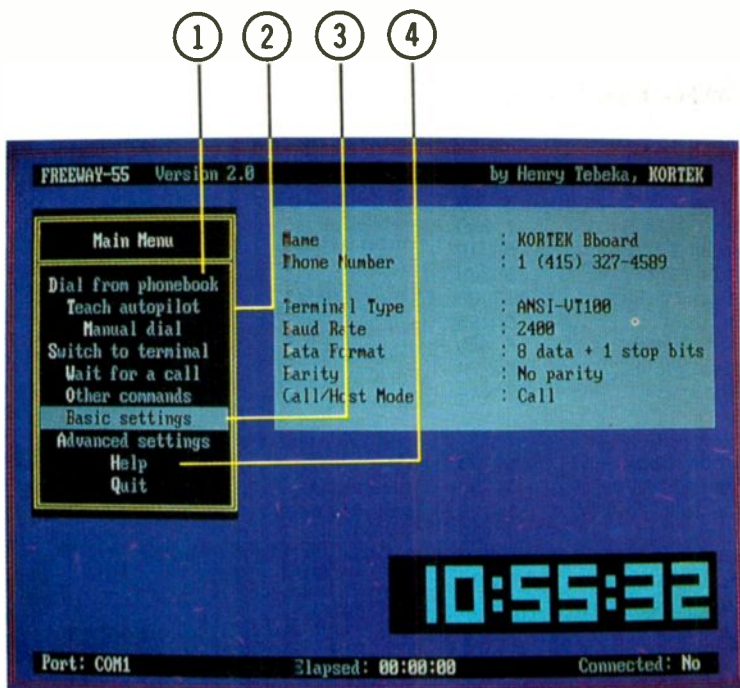

- 4 **On-Line Help:** Even though Freeway is very easy to use, we all need a hint now and then. Every line of every menu has on-line help at the touch of a key.

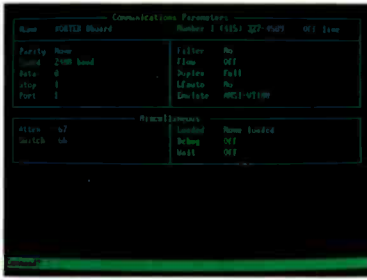

Over 30,000 satisfied users
of previous version (KX-COM)

Crosstalk® Emulation: At the touch of a function key, you can switch from the menu interface to a command line interface. Crosstalk® users will feel right at home, and everyone can use whichever interface suits them best.

Terminal Emulation and File Transfer: We haven't forgotten the basics. Freeway emulates ANSI VT-100, VT52, and TTY. It offers seven file transfer protocols, including the new ultra-fast, ultra-reliable Freeway protocol. Why a new protocol? Because it is better — it sets many parameters automatically, adapts packet sizes to line conditions, and, in short, gets files through the first time.

Gory details: TTY, VT100, VT52 emulation. 75-115.2k baud. ASCII, Kermit, Xmodem, Ymodem, Ymodem batch, Compuserve-B, and Freeway protocols supported. Phonebooks store over 20 parameters for each host, including phone number, baud rate, LF filter, bit 8 filter, fold to uppercase, null line and tab expansions, flow control characters, and intercharacter and interline delays. Privacy passwords protect phonebooks. Global parameters separated from host-dependent parameters. Script facility, with full power of Freeway. Includes conditional branches, subroutines, and string and numeric variables. Elapsed session time available as a script variable. Autopilot replays logon sequence. Big digital clock. Can beep, call a host, or run a script at specified times. Session time limit warning. Emulation of Crosstalk® interface; lots of extra commands. Copy, erase, rename files. Built-in page and line editors. Configurable for most modems, including non-Hayes. Auto-redial; programmable number of and delay between tries. Parallel command and menu interfaces. On-line help for each menu line. Cleans windows. Cooks omelettes.

nication software.

FREWAY →

It seems unbelievable to get such a complete communications software package for only \$24.95. But it's true! With its many powerful features, Freeway handles all your communications applications with ease. It has full terminal emulation, full file transfer capabilities, baud rates up to 115200, and many other features, and it uses all the easy Freeway interfaces with pop-up menus. Freeway is a powerful tool, and it is only \$24.95! (non-copy protected)

\$24.95
ONLY!
Introductory price

FREWAY → Advanced

Freeway Advanced has of course all the power and simplicity of Freeway with more features there when you need them:

- Crosstalk emulation and a powerful script language jammed with features Crosstalk® doesn't have. A BBoard script is supplied free as an application (callers can change drives, directories, and upload and download files using any protocol).
- More communication parameters; filters, flow control, delays. Passwords protect phonebooks and unattended mode. (non-copy protected)

\$89.95
ONLY!
Introductory price

System Requirements: IBM PC, XT, AT, or PS/2 or 100% compatible.

Kortek BBoard (415) 327-4589

Order now! Call toll-free
1-800/327-0310

Or, send a check or major credit card number, including \$5 for postage and handling, CA residents add 7% sales tax

Crosstalk® is a registered trademark of Digital Communication Associates Inc.

Kortek Inc. has no affiliation with and no relationship with Digital Communication Associates Inc.

Artag, Lincoln Graphics & JDLH



KORTEK INC.
505 Hamilton Avenue
Palo Alto, California 94301
☎ (415) 327-4555



Inquiry 148

"A Work of Art"

AA

TO: Joan Prentiss-Winston, CEO
FROM: Bertram W. Finch, CFO

PROPOSAL

After researching all our options, I can confidently recommend a software product by SoftCraft, Inc. The product is called Fancy Font and it would meet all our typesetting needs. Fancy Font is cost effective and is compatible with all our laser and dot matrix printers, as well as any of our installed word processors.

Fancy Font can meet the needs of the following departments:

Graphics

G Our graphic artists will find Fancy Font useful for creating vu-graphs, presentation materials and advertisements. There are now commands to create and work with graphic images. SoftCraft also offers a special service to digitize logos and symbols our artists design.



Documentation



Fancy Font will save time and money in the production of our manuals and technical documents that require several sized chapter, title and section headings in a variety of text formats including portrait and landscape mode. The kern option creates ligatures for the most polished looking documents.

Manufacturing



With Fancy Font, we can design our own product labels. The SoftCraft font library even has a bar code font available for inventory control purposes.

Research and Development

Fancy Font provides the special symbol and mathematical fonts this department needs to produce proposals and technical reports containing scientific notation and mathematical formulae.

$$\pi(n) = \sum_{k=2}^n \left[\frac{\phi(k)}{k-1} \right]$$

Public Relations and Marketing



Fancy Font can make all our promotional materials look more professional. It is a software package versatile enough to produce news releases, invitations, company newsletters, even last-minute sales presentations, all looking as though they had been done by a professional typesetting service.

Accounting

Fancy Font can produce columns of figures in small typefaces and can be used with our Lotus spreadsheets and graphs. Perfect for doing annual financial reports.



RECOMMENDATION: Fancy Font can meet the special needs of virtually every department in the company. No special hardware or installation is required, so we can use it as soon as it arrives. Fancy Font would cut company costs by reducing printing and typesetting fees and bring in-house, several services that we now send out. I recommend that we purchase Fancy Font immediately.

Bertram W. Finch

Bertram W. Finch

Create boxes shaded or patterned according to your specifications. (new!)

Standard fonts include Sans Serif, Roman, *Script*, $\text{\textcircled{d}}$ English, bold, *italic* in sizes from 8 to 24 points.

Automatic column command. (new!)

Includes over 1500 mathematical, foreign language and special symbols that can be scaled to any size up to 1 inch.

Drop in graphic images captured from a file or from the screen display of programs such as Lotus 1-2-3. (new!)

Mix different sizes and styles of native and SoftCraft fonts on the same line.

Create and print your own characters and logos up to 2" high and 2 2/3" wide.

Special formatting features let you wordwrap, or position text centered, justified, flush left or right, and much more.

Automatic pagination makes formatting long documents easy! No length limits!

Kerning option kerns a document and automatically forms ligatures.

Hundreds of optional fonts from 4 to 72 points available.

Send us your logo or signature for digitization.

Let Fancy Font turn your printer into a personal typesetter.

Fancy Font gives you the utmost in document versatility by allowing you to mix a variety of font styles and sizes in either portrait or landscape mode with your printer's native fonts.

If you have an inexpensive dot matrix printer, Fancy Font turns low-resolution print quality into stunning high-resolution, proportionally-spaced text rivaling laser printer output.

If you have a laser printer, Fancy Font turns it into an economical desktop publishing system. Fancy Font prints with a wide variety of typestyles and sizes normally available only from expensive typesetting services.

Fancy Font runs on all IBM PC's and compatibles and works with word processors, spreadsheet and database programs.

SoftCraft, Inc. offers a wide variety of personal typesetting software and fonts. Call our toll-free number for information on these and other products:

Fancy Font	\$180
Fancy Word	\$140
Laser Fonts	\$180
SoftCraft Font Editor	\$290
Business Font Pack	\$90
Font disks	\$15 each

Now with graphics!

 **SoftCraft, Inc.**

16 N. Carroll St., Suite 500, Madison, WI 53703 (608) 257-3300 1-800-351-0500

The sample letter above was printed in one pass with Fancy Font on an HP LaserJet+.

Inquiry 265 for End-Users. Inquiry 266 for DEALERS ONLY.

Features

A Programmer's Introduction to OS/2	101
<i>by Ray Duncan</i>	
The New Generation: A Closer Look	110
<i>by Richard Grehan</i>	
Ciarcia's Circuit Cellar: Build the Circuit Cellar AT Computer, Part 1	115
<i>by Steve Ciarcia</i>	
Programming Project: Crafting Reusable Software in Modula-2	123
<i>by Hanna Oktaba and René Berber</i>	
Programming Insight: Teaching Old Screens New Tricks	129
<i>by Michael J. Sorens</i>	
Constructing an Associative Memory	137
<i>by Bart Kosko</i>	
Karmarkar's Algorithm	146
<i>by Andrew M. Rockett and John C. Stevenson</i>	

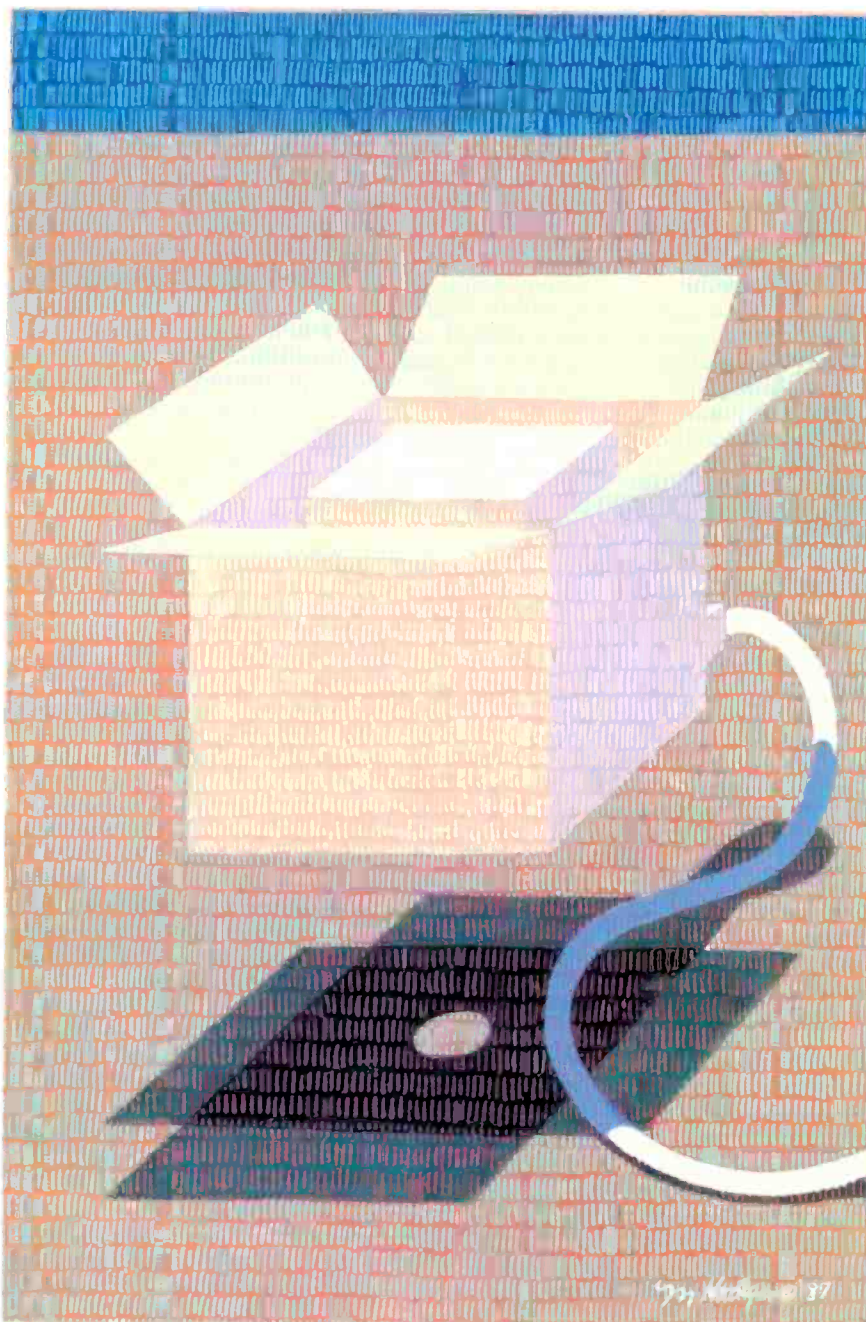

The Diconix 150. Take it or leave it.

The world's most portable printer performs as well on your desktop as it does when you're on the road. The small footprint reduces desktop clutter, while it enlarges a small budget.

PC
MAGAZINE
The Best
of 1986

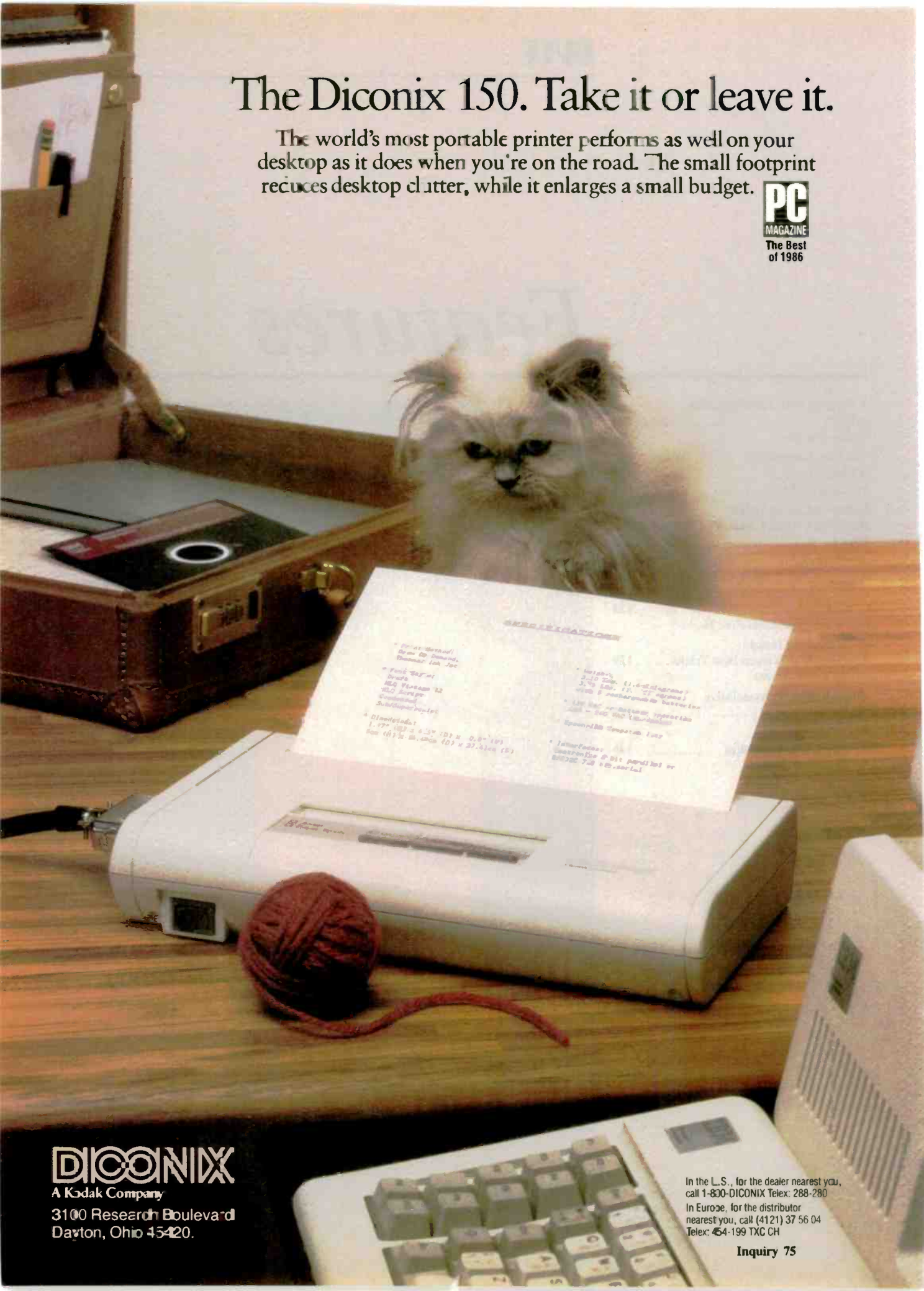

DICONIX

A Kodak Company

3100 Research Boulevard
Dayton, Ohio 45420.

In the U.S., for the dealer nearest you,
call 1-800-DICONIX Telex: 288-280
In Europe, for the distributor
nearest you, call (4121) 37 56 04
Telex: 454-199 TXC CH

Inquiry 75

Ray Duncan

A Programmer's Introduction to OS/2

Writing your first OS/2 application



OS/2 is Microsoft's multitasking, virtual-memory, single-user operating system for personal computers based on the Intel 80286 and 80386 microprocessors. Various referred to in the press during the last two years as DOS 5, NewDOS, Advanced DOS, ADOS, and 286DOS, OS/2 is the first software product born of the Microsoft/IBM joint development agreement of August 1985.

OS/2 falls between Microsoft's MS-DOS single-tasking operating system and the Xenix multiuser, multitasking operating system. Although it is compatible with MS-DOS file systems and can run many existing MS-DOS applications, and although it has a hierarchical directory structure, I/O redirection, and some interprocess communication mechanisms similar to Xenix, it is neither an overblown MS-DOS nor a stripped-down Xenix. It is a completely new operating system designed to support high-performance, intensely interactive, "personal-productivity," and networking applications in a business environment.

The retail version of the basic OS/2 operating system will not reach users until early 1988, and the graphic user-interface layer (the protected-mode Windows/Presentation Manager) will arrive even later. However, to help programmers get familiar with the new system as quickly as possible and encourage the early port of existing applications to the new protected-mode environment, both Microsoft and IBM are directing earnest evangelical efforts at the software-development community. Both companies have announced an aggressive schedule of seminars for developers throughout the summer of 1987, and both have shipped software-development kits containing prerelease versions of the operating sys-

tem and programming tools.

This article is the first in a series of three that will look at how to write programs to run under OS/2. The other articles will appear next month and in the Fall 1987 *Inside the IBM PCs* issue.

Key Features of OS/2

MS-DOS runs the 80286 processor in real mode, which is essentially an 8086-emulation mode. Even though the benefits of the 80286's higher clock rates and more efficient instruction set were not insignificant, both programmers and users found the persistence of the real mode's 1-megabyte-addressing limitation frustrating. OS/2 runs the 80286 in its preferred protected mode, with a physical address space of 16 megabytes and a virtual address space of 1 gigabyte. This use of protected mode has important implications for the structure of the operating system itself and for the design and operation of applications programs. (You can find a more detailed introduction to protected mode in Ross Nelson's article "A Protected-Mode Program for the PC AT" in the Fall 1986 *Inside the IBM PCs*, or in Intel's *iAPX286 Operating System Writer's Guide*.)

From the programmer's point of view, the key features of software development under OS/2 are a new application program interface (API), preemptive multitasking, interprocess-communication facilities, memory protection and virtual memory, dynamic linking, and compatibility with MS-DOS.

Application Program Interface

The OS/2 kernel provides about 200 services to applications programs executing under its control. Collectively they are referred to as the OS/2 API. You invoke all these services with *far calls* that are resolved at load time (see Dynamic Link-

ing on page 104). Parameters—a mixture of values and addresses of values or structures—are pushed onto the stack prior to the call. A status code is returned in register AX: 0 if the function succeeded, or an error code if the function failed. Other returned values are placed in variables or arrays whose addresses were passed in the original call.

The OS/2 API functions fall into four major categories. DOSxxx calls are general services, including file and record I/O, device monitors, dynamic linking, multitasking, interprocess communication, memory management, timers, and internationalization support. VIOxxx calls display characters or strings with or without associated attributes, read back characters (and optionally, their attributes) from the display buffer, read or set cursor position and type, scroll up/down/left/right, set or get video mode, and put up or take down the pop-up window. KBDxxx calls are for keyboard status and input. MOUxxx calls read pointing-device position, status, and state of buttons; they also hide or reveal the pointer or set its shape.

A small subset of the above calls, known as the family API, has direct equivalents in MS-DOS function calls. OS/2 programs that restrict themselves to using the family API calls can be linked and bound in a special manner that lets them run in three environments: MS-DOS 2.x/3.x, the DOS 3.x compatibility box of OS/2, or protected mode under OS/2. Such programs are called *family*

continued

Ray Duncan is author of *Advanced MS-DOS: Microsoft's Guide for Assembly Language and C Programmers*, Microsoft Press, 1986. He can be reached at P.O. Box 10430, Marina del Rey, CA 90295.

The user's interface to OS/2's multitasking capabilities is simple.

apps or *bound apps*; the programming tools in the software-development kits are supplied in this form. (For more information on building family apps, see "Microsoft's New DOS," by Eva White and Richard Grehan in the June BYTE.)

The Windows/Presentation Manager offers applications programs another 500 or so functions that create, destroy, and control the appearance and size of windows, perform device-independent graphic output, put up and take down the pull-down menus, load resources, and so on. I'll ignore these for the present, except to note that when Windows/Presentation Manager is present, it replaces the system's default VIO and KBD routines with new services that let a well-behaved text application run in a window without its knowledge.

An interesting feature of the new OS/2 API is that it is equally efficient to call it from either a high-level language or from assembly language. Consider the function DOSSLEEP (probably the simplest useful function in the OS/2 API), which is called with a double-word value in milliseconds and suspends the caller's execution for the specified interval. The assembly-language form of the function call is

```
extern DOSSLEEP:far
.
.
.
push 0      ; push double value
            1000
push 1000   ; to sleep for 1
            second
call DOSSLEEP; transfer to OS/2
or ax,ax   ; did call succeed?
jnz error  ; jump if call
            failed
```

To call an OS/2 API function from a C program, you simply declare it as far Pascal (i.e., parameters pushed left to right, the called routine clears the stack) and then invoke it directly:

```
extern unsigned far pascal
DOSSLEEP(unsigned long);
.
.
status=DOSSLEEP(1000L);
```

The OS/2 C compiler generates the right code for the call automatically.

There is no execution time or space penalty, there is no need for intermediate library functions to shift parameters around or pop them into registers before transferring to the operating system, and the source code is far more compact and readable than its assembly language counterpart.

Although the OS/2 API is a considerable architectural change from the familiar INT 21h of MS-DOS, it offers many significant advantages. The API lets OS/2 take full advantage of the 80286's ability to automatically copy parameters from the caller's stack to the receiving routine's stack. The API also enforces the separation between kernel and user-privilege levels by protected-mode call gates. The API might make subsequent conversion of applications for a true 32-bit 80386 version of OS/2 almost trivial, and it raises the possibility that the entire operating system and its applications could someday be ported to a processor with a non-Intel architecture, such as the Motorola 68020.

Preemptive Multitasking

Preemptive multitasking refers to the operating system's ability to allocate processor time between multiple tasks in a manner that is invisible to those programs. It is sometimes called time-slicing. A hardware interrupt, called the timer tick, which is generated by a programmable timer chip, lets the operating system regain control at predetermined intervals.

After updating the current date and time, control is transferred to a scheduler that maintains a list of the active tasks and their state. If the scheduler determines that the currently executing program has exhausted its time slice or that another program with a higher priority is ready to execute, the scheduler suspends (preempts) the current program and gives control to another program.

The user's interface to OS/2's multitasking capabilities is simple and easy to understand. A special supervisory program, called the session manager, lets you start up one or more copies of the system's command processor (CMD.EXE, the protected-mode counterpart of MS-DOS's COMMAND.COM). Each command processor and the programs that users launch from it are collectively termed a screen group and own a virtual screen buffer that receives all the output from the programs in that group. Users can cycle from one screen group to another with the aid of the session manager's hot key; when a screen group is brought to the foreground, its virtual screen buffer is mapped to the physical screen, and the programs in that group

acquire control of the keyboard.

The programmer's view of multitasking under OS/2 is somewhat more complex and involves three types of system objects: screen groups, processes, and threads. Each screen group contains one or more active processes, and each process contains one or more active threads. The simplest case of a process is conceptually similar to a program loaded under MS-DOS: The process is initiated when the operating system allocates some memory, loads the necessary code and data from a disk file, and gives it control at an entry point specified in the file. Subsequently, the process can obtain and release other resources (such as access to disk files and additional memory), perform input or output, and spawn other processes by calls to the operating system. A process's membership in a screen group depends strictly on the membership of its "parent" process; similarly, any "child" processes that it creates will belong to the same screen group.

The OS/2 concept of threads is rather novel. A thread is a point of execution within a process and is associated with a stack, general register contents, and a state (i.e., waiting for some event, ready to execute, or executing).

Each process has exactly one thread when it is created, whose initial execution point is the entry point of that process. But that thread can create additional threads that then run asynchronously from the first and share ownership of all the processes' resources and "near data segments" (DGROUP).

Threads within a process can dynamically suspend, reactivate, and vary the priorities of one another and can perform input and output autonomously: Any necessary serialization of I/O is done within OS/2. Communication between threads is fast, since it is typically performed through shared data structures and does not need to involve operating system calls.

Interprocess Communication

OS/2 supports all the major methods of interprocess communication found in other multitasking operating systems. RAM semaphores are used for local signaling or resource synchronization between multiple threads in the same process. System semaphores that are called global objects can be used for signaling or resource synchronization between processes. Pipes, as in Unix, allow high-performance transfer of variable-length messages between closely related processes (usually a parent and its child processes).

Shared memory, named global memory segments, can be accessed by two or

continued



YOUR PC WANTS YOU TO GIVE IT THE SAME ADVANTAGE YOU GIVE YOUR TAPE DECK AND VCR.

It's only fair. Not to mention logical. PC's want to perform as well as all your other sophisticated electronic equipment. If you're like millions of informed people throughout the world, you rely on the ultimate in audio and video recording performance. You rely on TDK.

Well, you should also rely on TDK when it comes to your computer. TDK's Floppy Disks provide the same consistently high performance. The same level of absolute quality. Which is understandable since all TDK products share an unparalleled level of technical superiority that spans over 50 years.

In fact, TDK is the world's largest manufacturer of magnetic media.

What's more, they're also a major producer of electronic component parts, including the most sophisticated heads for disk drives. What a strategic advantage! With vital "inside" information like that, it's no wonder their disks provide error-free performance.

So, if you want to put a smile on your computer's face, choose from TDK's family of 5.25-inch standard, 5.25-inch High Density and 3.5-inch No-Risk™ Disks. It's to you and your PC's advantage.

 **TDK**
THE NO-RISK™ DISK.



Northeastern Region: 516-625-0100; Southern Region: 404-948-1346; Midwestern Region: 312-676-5356; Western Region: 714-863-1844

© 1986 TDK Electronics Corp.

more processes. Queues named global objects have several features: You can order messages in the queue by FIFO (first in/first out), LIFO (last in/last out), or priority, the queue can grow to almost any size, and many processes can write messages to the queue, but only the queue creator can remove them. Event flags, similar to those in Unix, are used to communicate between related processes and can simulate a software interrupt.

Memory Protection and Virtual Memory

All the processors in the Intel 80x86 family generate memory addresses by combining the contents of a segment register (which you can think of as a base pointer) with an absolute or relative offset. On the 8086 or the 80286 in real mode, the value in a segment register is simply a paragraph address (a 20-bit physical address divided by 16). In protected mode, an additional level of addressing indirection is added. The value in a segment register is a selector, which is an index to an entry in a descriptor table that contains the base address and length of a memory segment, segment attributes (executable, read-only, or read/write), and privilege information. Each time a program makes a memory reference, the hardware accesses the descriptor table to generate the physical address and simultaneously checks to make sure that the memory access is valid.

Protected-mode addressing completely isolates tasks from one another. The descriptor tables themselves are not accessible by applications programs; only the operating system can manipulate them. If a program attempts to read or write a memory area that does not belong to it or calls an operating system routine to which it has not been given access, a hardware interrupt is generated that lets the operating system terminate the errant program. The combination of preemptive multitasking and memory protection contributes to a robust environment: There is little opportunity in protected mode for an ill-behaved program to bring the entire system down by going into a loop or writing on code or data owned by another program.

The flip side of the memory-protection coin is virtual memory. OS/2 can manage up to 16 megabytes of physical memory, but the amount of installed RAM is nearly irrelevant to the average applications program running in protected mode.

When the sum of the memory owned by active programs in the system exceeds the amount of physical memory, memory segments are rolled in and out from a swap file as needed (or just discarded and

reloaded in the case of code or read-only data segments). This segment-swapping is accomplished by a module of OS/2 known as the memory manager, with the aid of the processor's hardware memory-protection mechanisms, and the process is completely invisible to applications programs. The theoretical limit on the amount of memory a program can own or share is around half a gigabyte, but the practical limit is the amount of physical RAM plus the swapping space available on the hard disk.

Dynamic Linking

The 80286's support for protected virtual memory makes it possible to place frequently used procedures, including most of the OS/2 and graphic user-interface services available to applications programs, into special files known as dynamic link (dynamlink) libraries. The routines in these libraries can be shared by all the programs that require them and are not loaded from disk into physical memory until they are needed. Placing common procedures in dynamlink libraries lets you alter, improve, or replace those routines without any change to the applications programs that invoke them.

The calls from a program to the routines in a dynamlink library are resolved in two stages. The linker is informed that a particular external name is a dynamlink routine by either an `Import` statement in the program's module-definition file or by finding a special "stub" record in an object-module library. It then builds the information necessary for deferred linking into the program's .EXE-file header: the names of the dynamlink routines that are needed, the modules in which they will be found, and a list for each routine of all the addresses within the program where it is called. When you load the program for execution, the list of imported routines is examined, any external routines that are not already resident in memory are fetched from the disk, and the addresses within the calling program are fixed up appropriately. You can think of this as late binding.

Compatibility with MS-DOS

OS/2 provides upward compatibility and a smooth transition from MS-DOS at three levels: the user interface, the file system, and the DOS 3.x compatibility box.

The command-line interface of OS/2 version 1.0 is identical to that of MS-DOS, with the exception of a few new or enhanced commands, batch-file directives, and `CONFIG.SYS` file options. The session manager, which is triggered by a hot key and lets the user move from one screen group and command proces-

sor to another, is self-explanatory, and its use becomes natural very quickly. Adaptation to the Windows/PM, when it arrives, will also be easy: Its methods of operation and pull-down menus are quite similar to that of Microsoft Windows except that it uses overlapping rather than tiled windows, and you launch programs from a list of long, descriptive names rather than double-clicking on a filename in a disk-directory listing.

The file structure for both flexible and fixed disks—that is, the layout of the partition table, directories, file-allocation tables, and the files area—is exactly the same for the initial release of OS/2 as for MS-DOS. This means that you won't be escaping the 32-megabyte volume limit or the 8-character filename limit for some time yet. However, it does let developers exchange files and move back and forth between the two environments with a minimum of difficulty. OS/2's provisions for mountable file systems portend release from some of the historical MS-DOS limitations.

The DOS 3.x compatibility box is not a box at all, but a component of the OS/2 operating system that lets one "old" application designed for MS-DOS run at a time in the 80286's real mode alongside "new" protected-mode applications. Requests by the real-mode application for MS-DOS services are trapped by OS/2 and translated into API calls, switching back and forth between real mode and protected mode as necessary to perform I/O and other services. The user can determine how much memory will be allocated to the DOS 3.x box by an entry in the `CONFIG.SYS` file or disable it completely.

One disadvantage of the DOS 3.x box is that it makes the system vulnerable as a whole. Ill-behaved MS-DOS programs that manipulate the hardware directly or take over interrupt vectors can cause problems or even a hard crash—this is unfortunately the trade-off for being able to use the old programs at all.

A Simple OS/2 Application

An OS/2 application is built from two basic elements: source files that can be compiled or assembled into relocatable object modules and a module-definition file that describes the program's segment behavior (see figure 1).

In a traditionally trivial program that displays the message "Hello World!," the file `HELLO.ASM` contains the assembly language source code for the program (see listing 1). It looks similar to an equivalent MS-DOS program, with a few exceptions.

The directive `.286c` permits the as-

continued

Back To School Special - Save Over 50%

Prices good through October 31.

C COMPILER



The Powerful Mix
C COMPILER

Harness the Power of the C Language
with this full featured Compiler

MIX
software

Only \$19.95

CTRACE DEBUGGER \$19.95

The perfect companion for MIX C is our exciting new C source debugger. Ctrace is unlike any debugger you've ever seen. It brings your programs to life on the screen. You'll see your variable values changing as you watch your C source code executing. The animated trace shows you the flow of execution, statement by statement. It's like watching the bouncing ball as the cursor dances over your C program.

Ctrace is very simple to operate. Commands are executed with a single keystroke. Pop up menus list the command options. Pop up messages alert you when anything important happens. There are 6 windows of information: source, output, variables, watch, memory, and symbols. You can view as many as 4 windows at once. The function keys make it easy to quickly choose among 8 different views.

The combination of Ctrace with MIX C makes C programming a real joy. MIX C provides the power of a compiler while Ctrace provides an execution environment that's more elegant than an interpreter.

SPLIT-SCREEN EDITOR \$19.95

Another great companion to the MIX C compiler is our split-screen editor. It makes writing programs even faster and easier. With the MIX Editor, you can compile, link, and execute your program at the touch of a key. Compiling is fast because the MIX C compiler reads the program directly from memory. Correcting errors is easy because the editor automatically positions the cursor to the first error in the program. The editor is similar to Micropro's WordStar but with additional programming features like split-screen, macros, and much more. Use it for all your programming needs.

ASM UTILITY \$10.00

Our ASM utility is available if you want to link assembly language functions to your C programs. It works with Microsoft's MASM or M80 assemblers. Call assembly language functions just like C functions. Call C functions from assembly language. Lots of useful assembly language functions are included as examples.

C for yourself

Get off to a fast start with MIX C. Our comprehensive book and nimble C compiler will have you programming in C before you know it.

Our book is your teacher. You'll start right away, compiling and executing C programs. The tutorial takes you step by step through the C language. You'll learn by example with a book that's chock-full of sample programs. And the programs aren't just fluff. They teach you the important C concepts. An amortization program teaches you how to use pointers to functions. A data base program teaches you how to manage memory dynamically. It's the best hands on training available.

You'll love working with our C compiler. It's half as large and twice as fast as other C compilers. In fact, it's the only full featured C compiler that can be operated comfortably on floppy disks. And as you would expect, MIX C is easy to use. It produces a complete program listing with compile errors clearly identified and explained. If you've been frustrated by other C compilers, don't throw in the towel until you've tried ours. There's a big difference.

Although it's small, MIX C is not a subset. MIX C supports the full K&R standard, including the extensions that are often omitted in other C compilers. MIX C comes complete with a comprehensive book, a standard library of more than 175 functions, a blazingly fast linker, and tools for optimizing your programs for minimal space or maximum speed. All of this is yours for the incredibly low price of \$19.95. That's little more than the cost of most C books alone. So don't be left behind. Order your copy today and find out why everyone is switching to C.

TO ORDER CALL TOLL FREE: 1-800-523-9520

For technical support and for orders inside Texas please call (214) 783-6001 Or Contact one of our Distributors in Canada: Saraguay 1-800-387-1288 • France: Info/Tech 1-33-44-06-48 • Australia: Techflow 047-586924 • Switzerland: DMB Communication CH-0-523-31817 • England: Analytical 0703-262099

System Requirements: MSDOS/PCDOS 2.0 or higher; 256K Memory; 1 Disk Drive or CP/M 2.2 or higher (280); 55K Memory; 1 Disk Drive (2 recommended)
(Ctrace not available for CP/M)

The MIX C Works

Only \$39.90



Save \$29.95 on the Works
includes Editor, C Compiler,
Ctrace, & ASM Utility

Product	Price	Total
__Ctrace	(\$19.95)	\$ _____
__C Compiler	(\$19.95)	\$ _____
__ASM Utility	(\$10.00)	\$ _____
__Split-Screen Editor	(\$19.95)	\$ _____
__The MIX C Works	(\$39.90)	\$ _____
(Includes all of above)		
Subtotal		\$ _____
Texas Residents Add		
7.25% Sales Tax		\$ _____
Add Shipping Charges		\$ _____
In USA: add \$5 per order		
In Canada: add \$10 per order		
Overseas: add \$10 for editor		
add \$20 for compiler		
add \$30 for Works		
Total of Your Order		\$ _____

30 Day Money Back Guarantee Net Copy Protected

Please check method of payment

Check Money Order MC/VISA

Card # _____

Expiration Date _____

Please give name of computer _____

Please check operating system

MSDOS/PCDOS CP/M

Please check disk size

5 1/4" 3 1/2" 8"

Please check disk format if CP/M

SSSD SSDD DSDD

Your Name _____

Street _____

City _____

State _____ Zip _____

Telephone (_____) _____

Country _____

MIX software 1132 Commerce Drive
Richardson, Tx 75081
(214) 783-6001

Ask about our volume discounts!
Dealer Inquiries Welcome

B

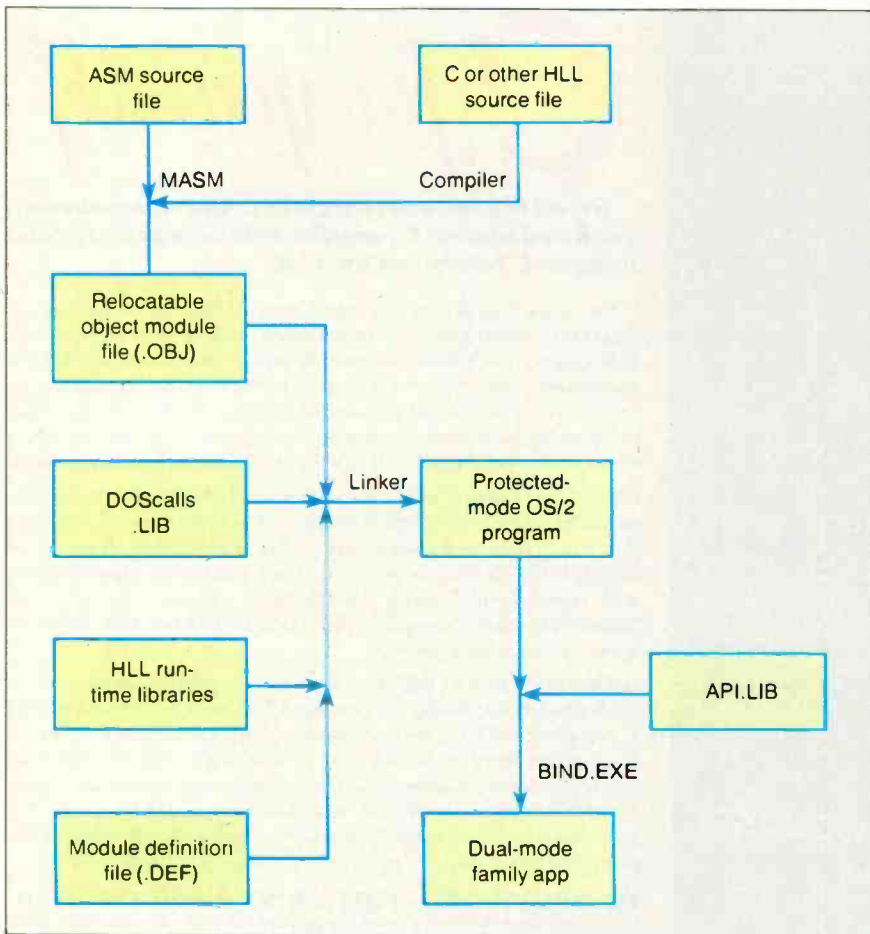

Figure 1: The procedure for creating protected-mode and dual-mode, or "family," applications for OS/2.

CS:IP	Points to the program's initial entry point
SS:SP	Points to the base of the program's stack
DS	Points to the program's automatic data segment (DGROUP)
AX	Contains the segment selector of the environment block
BX	Contains the offset of the command line at the end of the environment block

Figure 2: Conditions at entry to a protected-mode OS/2 application.

```

NAME HELLO           ; executable name
PROTMODE             ; protected mode only
DATA MOVABLE
CODE MOVABLE PURE
STACKSIZE 4096
  
```

Figure 3: A module-definition file, HELLO.DEF, for the sample application file HELLO.EXE. Note that the stack size is declared here rather than in the HELLO.ASM file. If this were a C program, the heapsize would also be declared in this file.

sembly of 80286 nonprivileged instructions that are not present in the 8086 instruction set. The handiest of these is the "push immediate" instruction, which saves time and space when you set up parameters for an OS/2 API call.

References to OS/2 API entry points are accomplished with EXTRN directives, assigning a far attribute to the external name. The assembler does not know anything about the nature of the procedure represented by the external name, but only that it has to generate an intersegment call to reach it and that the final address will be fixed up later.

The declaration of DGROUP with the group directive is mandatory. This is a "magic" name that specifies the application's automatic data segment, which also contains the default stack and heap. The _TEXT and _DATA segment names are simply conventions used by the Microsoft high-level language compilers. Unlike MS-DOS, OS/2 automatically initializes the DS register to point to DGROUP before it transfers control to the program's entry point (the other conditions at entry to a protected-mode application are summarized in figure 2). This is also reflected in the Assume directive that follows the segment declaration of _TEXT.

The remainder of the HELLO.ASM file contains nothing unexpected. Two calls to OS/2 services are demonstrated: DOSWRITE performs a synchronous write to a file or a device, and DOSEXIT terminates the application with a return code. DOSWRITE is the counterpart to MS-DOS's INT 21h function 40h, and DOSEXIT is comparable to MS-DOS's INT 21h function 4Ch. The last line in the source file is an end directive that defines the program's entry point in the usual manner.

The file HELLO.DEF (see figure 3) is the module-definition file for the program. It demonstrates only a few of the possible commands and options that can be used in this file. The name directive states that this is an executable program rather than a dynamic-link library (whose .DEF file would contain library instead).

Protmode signifies that the program will run in protected mode, while the lines beginning with code and data declare a few of the many possible segment attributes. The stack size for the program's initial thread of execution is defined by the stack directive; if this were a C program, an additional heapsize command would specify the initial size of the program's local heap.

Building the Application

To build the final executable program, you first translate the file HELLO.ASM

to the relocatable object module HELLO.OBJ:

```
[C: \ OS2 \ SOURCE \ HELLO]
MASM <Enter>
```

```
IBM Personal Computer MACRO
Assembler Version 3.00
(C) Copyright IBM Corp 1981,
1984, 1987
(C) Copyright Microsoft Corp
1981, 1983, 1984, 1985, 1987
```

```
Source filename [.ASM]:
HELLO <Enter>
Object filename [HELLO.OBJ]:
<Enter>
Source listing [NUL.LST]:
<Enter>
Cross-reference [NUL.CRF]:
<Enter>
5506 Bytes symbol space free
```

```
0 Warning Errors
0 Severe Errors
```

The Microsoft segmented executable linker—the new linker supplied in the OS/2 software-development kit—combines the object module HELLO.OBJ with the module-definition file (HELLO.DEF), a library that contains special stub records for the OS/2 API dynamic links (DOSCALLS.LIB) and any applicable run-time libraries (none in this case) to create the protected-mode executable file HELLO.EXE:

```
[C: \ OS2 \ SOURCE \ HELLO] LINK
<Enter>
```

```
Microsoft (R) Segmented-
Executable Linker Version
5.00.21
Copyright (C) Microsoft Corp
1984, 1985, 1986. All rights
reserved.
```

```
Object Modules [.OBJ]: HELLO
<Enter>
Run File [HELLO.EXE]: <Enter>
List File [NUL.MAP]: <Enter>
Libraries [.LIB]: DOSCALLS
<Enter>
Definitions File [NUL.DEF]:
HELLO <Enter>
```

You can also supply the assembler and linker with their parameters via the command-line or response files, or automate the process by means of a make file and the MAKE.EXE utility (see figure 4).

The output of the segmented executable linker is an .EXE file with the same structure as the .EXE files used in real-mode Windows—the so-called New.EXE

continued

Listing 1: *The source file HELLO.ASM for the sample application HELLO.EXE.*

```
name    hello
page    55,132
title   HELLO --- print Hello on terminal
        .286c
;
; HELLO.EXE utility, demonstrating a simple assembly-language program for
; Microsoft OS/2.
;
; (C) 1986 Ray Duncan
;
stdin   equ    0 ; handle for standard input
stdout  equ    1 ; handle for standard output
stderr  equ    2 ; handle for standard error
extern  DOSWRITE:far
extern  DOSEXIT:far

DGROUP  group   _DATA

_DATA   segment word public 'DATA'

msg     db      0dh,0ah,"Hello Protected-Mode World!",0dh,0ah

msg_len equ    $-msg

wlen    dw      ? ; receives number of bytes written

_DATA   ends

_TEXT   segment byte public 'CODE'

        assume  cs:_TEXT,ds:DGROUP

print   proc    far

        push    stdout ; file handle for standard output
        push    ds ; long address of write buffer
        push    offset DGROUP:msg

        push    msg_len ; size of write buffer
        push    ds ; variable receives bytes written
        push    offset DGROUP:wlen

        call    DOSWRITE ; transfer to OS/2
        or     ax,ax ; test returned status
        jnz    error ; jump if write failed

        push    1 ; terminate all threads
        push    0 ; return success code
        call    DOSEXIT ; exit program

error:  push    1 ; terminate all threads
        push    1 ; return error code
        call    DOSEXIT ; exit program

print   endp

_TEXT   ends

        end     print
```

```
hello.obj : hello.asm
masm hello,hello,hello;

hello.exe : hello.obj hello.def hello
link /map /line hello,,,doscalls,hello
```

Figure 4: *A make file for the sample application HELLO.EXE.*

Jack2



INTEGRATED SOFTWARE

• Word Processing • Spreadsheet • Database • Graphics

**The Incredible JACK2[®] from Pecan
at the Incredible Introductory
Price of \$49.95* (regularly \$100)**

For the IBM PC and Compatibles Under DOS

**All it takes is one screen to do everything
you've always wanted to do, at one time.**

Word processing. Spreadsheet. Data base management. Charting. JACK2 is the first integrated software product to do them all, simultaneously, on a single screen. All without ever changing disks or exiting programs.

No need for windows. No need to close one file before you open another. And no need to learn a specialized computer language.

Easy to use. Easy to learn.

JACK2 is as easy to master as it is powerful to use. All commands are in English. All have the identical function throughout JACK2.

Integrated, the four applications of JACK2 offer unlimited potential as a business tool. Individually, they offer everything an expert could ask for.

Like multiple columns of word processing text on the same page. Spreadsheets that perform calculations in English, not with obscure formulas. No more complicated data base instructions. Even the charting function was designed for convenience.

Change a single piece of information in any one of the four related functions and JACK2 will change all the others, simultaneously, instantly and interactively. Now you can sort a data base. Perform spreadsheet calculations. Edit word processing text. And illustrate your results with a bar chart. All at once. All on the same screen.

Fast. Powerful. Because it was developed using UCSD Pascal™

From PC Magazine:

"Jack2's word processor is better than many dedicated word processors. It is easy to use, highly visual and delightfully fast."
"... a well-conceived, well executed program."
"... finishes a winner."

From PC World:

"... Jack2 is a likely choice."

*Half price Introductory offer is valid on orders received by Pecan up to 10/31/87.

NOT COPY PROTECTED

Mail your check or money order to:

Pecan Software Systems, Inc.

1410 39th Street

Brooklyn, New York 11218

(718) 851-3100

ITT TELEX NUMBER: 494-8910

CompuServe ID: 76703, 500

Pecan Software Europe
Oakfield Grove
Clifton Bristol England
272-733-633

Credit Card Orders
Call Toll Free

PECAN™
The UCSD Pascal Company

1-800-63-PECAN

(NYS) 1-800-45-PECAN

Please add \$4.50 for shipping within the US. Foreign orders add \$15.00 and make payment by bank draft payable in US dollars on a US bank. New York State residents add appropriate sales tax. UCSD Pascal is a trademark of the Regents of the University of California.

Inquiry 221

INTRODUCTION TO OS/2

format. The file has an elaborate header that contains the names of imported dynamic link routines and any attached resources and describes the locations, sizes, and attributes of the various segments within the file.

OS/2 uses the information in the header to allow for sharing of text segments between multiple instances of the same process, to discard and reload text (i.e., machine-code) segments and read-only data segments on demand, and to allocate the program's stack and heap, among other things.

Making a Family App

Since the HELLO.EXE file uses only the OS/2 functions DOSWRITE and DOSEXIT, both of which are members of the subset family API, it can be converted to a family app that runs in either the DOS 3.x compatibility box or in protected mode. To do this, you use the BIND.EXE utility and a special library named API.LIB as follows:

```
[C: \ OS2 \ SOURCE \ HELLO] BIND  
HELLO.EXE API.LIB <Enter>
```

The output of this process is a new HELLO.EXE file that can run in either real or protected mode on an 80286 machine. To truly generalize this program and obtain a HELLO.EXE file that could run on any 80x86-based machine under MS-DOS or OS/2, you would have to replace all 80286-specific instructions in the source code with equivalent sequences that would run on an 8086/88. For example, you would need to replace the instruction

```
push msg_len
```

with

```
mov ax,msg_len  
push ax
```

You can easily locate the 80286-specific instructions in a program by removing the .286c directive from the source file and reassembling it; each instruction that will not run on an 8086/88 processor will then be flagged as an error.

Coming Attractions

Next month, I will develop and discuss a more complex application that makes use of OS/2's sophisticated multitasking as well as its interprocess-communication services. ■

[Editor's note: This article is adapted from Ray Duncan's book, *Advanced OS/2*, to be published by Microsoft Press in January 1988.]

Inquiry 101 →

New * FoxBASE+ 2.00

**Blazing Speed
New Features
Easier to Use**

Complete dBASE III PLUS Replacement . . . And Much More

Don't change your programs, databases, screens, or reports! FoxBASE+ makes your dBASE applications run like lightning *without changing one line*. And you can still use the best parts of dBASE—great interactive features like EDIT and BROWSE *plus* the full power of the "dot-prompt." Use FoxBASE+ in exactly the same, familiar, user-friendly way you use dBASE.

30+ Major Enhancements

User-Defined Functions, screen save & restore, VALID clause in GET's, built-in "light-bar" menus, 10 new commands, 4 new functions, and *much* more.

Faster Than Fast

FoxBASE+ was already the fastest dBASE product in existence—but based on *independent* benchmarks*, new FoxBASE+ 2.00 averages 73% faster. That's an average 3.2 times faster than Clipper, 4.3 times faster than Quicksilver, and 5.9 times faster than dBASE III PLUS.

80386 Version Available NOW

For ultimate speed *now*, FoxBASE+/386 runs about 50% faster than standard FoxBASE+ 2.00—over 10 times faster in some operations. It takes full advantage of protected mode and the giant memory capacity of the 80386 chip *today* . . . yet runs under standard MS-DOS.

Easier To Use

Don't worry about memory configuration or size. New FoxBASE+ 2.00 *automatically* optimizes memory usage as it runs . . . requires less memory yet runs faster. And because FoxBASE+ is completely interactive, you don't have to waste hours compiling and linking your programs.

FoxBASE+ Is Economical

Best of all, single-user MS-DOS FoxBASE+ 2.00 costs just \$395 and FoxBASE+/386 2.00 just \$595. Multi-user versions are also available.** And with our Royalty-Free Runtime you can distribute your FoxBASE+ applications freely and never pay another dime.

FoxEASE+ runs on the new IBM Personal System/2 and 3.5" diskettes are available at no additional cost.

So call (419) 874-0162 and ask for the details about FoxBASE+ 2.00 and our **money-back guarantee**. After all . . .

Nothing Runs Like a Fox.

FOXBASE 

FoxBASE, FoxBASE+, and FoxBASE+/386 are trademarks of Fox Software. dBASE III PLUS is a trademark of Ashton-Tate. Clipper is a trademark of Nantucket. Quicksilver is a trademark of WordTech Systems. Personal System/2 is a trademark of IBM.

* Using the suite of 48 comprehensive benchmarks published in Data Based Advisor, March 1987.

** Multi-User FoxBASE+ 2.00 for MS-DOS costs \$595. Multi-User XENIX version available at \$795.

Fox Software
27493 Holiday Lane, Perrysburg, Ohio 43551
(419) 374-0162 Telex: 6503040827

A Closer Look

Refinement of our benchmarks reveals some surprises about the relative speeds of 80386- and 68020-based machines.

BYTE started benchmarking the relative speeds of the new crop of 80386- and 68020-based machines within days of getting our hands on them. We presented the preliminary—and controversial—results in the July issue: The 80386-based machines were faster. We presented additional tests in the August issue, with much the same results.

However, our preliminary benchmark tests weren't ideal (some, in fact, contained outright errors, which I'll detail later). It's no small task to produce reliable benchmarks for systems with new architectures, especially when fundamental software-development tools (such as compilers) are few or in very early release.

So for this month's New Generation segment, I corrected problems in the original benchmarks and ran the improved code on the following lineup of hardware: the Mac SE, the Mac SE with General Computer's HyperCharger and Levco's Prodigy, the Mac II, the Arete 1100 supermicro, the Definion DSI-780, the IBM PC AT, the IBM PS/2 Model 80, the Kaypro 386, the ALR 386/2, and the Compaq 386.

You will find statistics for most of these entrants in our July and August New Generation articles.

Levco's Prodigy for the Mac SE is a 68020 with a 68881 math coprocessor, both of which run at 16 MHz. It includes 1 megabyte of RAM. The Definion DSI-780 is a coprocessor board for the IBM PC XT or AT (we plugged our DSI-780 into an 8-MHz AT) with a 16.67-MHz 68020 and 68881 and 4 megabytes of RAM. Both the Kaypro 386 and the ALR 386/2 use a 16-MHz 80386, but the ALR can accept a 10-MHz 80287 while the Kaypro (for reasons described later)

could not use a math coprocessor.

The July issue also contains source code listings for the benchmarks. Listings are also available on BIX and BYTENet, and on disk. (Order the July 1987 listings disk for the original benchmarks and the September disk for the corrected versions. See the card following page 256. For BYTENet listings, see page 4.)

Sort and Float

Our Quicksort benchmark (SORT.C) was unreliable; it produced a list that was only "sort of" sorted. The cure was to change the outer for loop in the quick() function to read:

```
for (i=lo, j=hi, pivot=base[hi];  
    i<j;)
```

I've simply changed the initialization portion of $j=hi-1$ to $j=hi$. Recall that the Quicksort algorithm operates by dividing the array being sorted into pairs of partitions such that one partition contains all elements greater than or equal to a given number (the "pivot"), and the other contains all elements less than or equal to the pivot. These partition pairs are again subdivided, and the process continues until the number of elements in each partition is 1. This is where the old SORT.C bombed; since j had been initialized to $hi-1$, the termination expression $i<j$ would not allow the for loop to execute.

All the times you see reported in tables 1a and 1b for the Sort benchmark were generated by the corrected program.

Next, we learned that optimizing compilers had a field day with the Float benchmark: I ran the original Float through MetaWare's 80386 HighC compiler and set its switches so I could view the 80386 assembly language that the compiler was generating. As it turned out, the compiler discovered that Float

consisted of repetitious instructions and could be optimized if the results were kept in registers and simply moved into memory as required. The compiler resolved the last six multiply instructions into simple MOVE instructions.

To get around this, I recoded Float so that the loop enclosed only a single multiply and a single divide, and I boosted the loop count to 70,000 to make up for the six pairs of assignment statements I had removed. I also borrowed a technique from the Dhrystone benchmark and added code to factor out the looping time (by timing an empty loop and subtracting this value from the total elapsed time). Consequently, the new version of Float should give a better picture of the time it takes a math coprocessor to execute floating-point multiplications and divisions.

Flotsam and Jetsam

Running these benchmarks on such a diverse array of hardware gave me a chance to uncover all kinds of interesting tidbits: • MetaWare's HighC compilers (I used two versions, one for generating 80286 code and one for generating 80386 code) provide a floating-point software switch that you can set to enable or disable the generation of in-line floating-point coprocessor code. They also come with two libraries: one that supports a math coprocessor, and one that performs floating-point operations using emulation code.

You would think that turning off the floating-point switch and linking with the emulation library would be enough to ensure that the .EXE file you were creating would ignore any floating-point unit (FPU) that might be present in the machine. Not so. There is an environment variable in MS-DOS called N087, which you set according to whether or not you have a coprocessor on-board. The upshot is that even if you have created a program using the emulator library, when you run it on a machine with a coprocessor and the N087 variable set to a null value (i.e., you have executed the DOS command SET N087=<return>), the program runs faster than if there was no coprocessor.

Clearly, the emulation library must be carrying coprocessor code with it, and the program brings this code into action if it finds an FPU. (Actually, this technique makes sense. It allows you to create code that runs on systems with or without FPUs; and if a system has an FPU, it gets a boost.) This means that you have to be careful about setting the compiler flag and the N087 variable when benchmarking. All the figures you see in table 1b for 80386 machines are from machines with an FPU (unless specified otherwise).

• To run the 80386 benchmarks, I executed the programs using Phar Lap's

RUN386 protected-mode environment (this is the only way you can run programs created by the 80386 version of the HighC compiler—see Matt Trask's review of 386|ASM/LINK 1.1e in the August BYTE). The latest version of RUN386 we had was 1.1e, and it simply locked up the Model 80. (The problem seemed to occur when RUN386 tried to load a benchmark program: The system would freeze and the hard disk access light would remain on.) When I reverted to an earlier version (1.1), it worked.

- The Kaypro 386 machine I tested had a socket for an 80387, but the machine refused to acknowledge an FPU when I plugged one in. The Kaypro uses Intel's 80386 motherboard, and there have been reports that Intel's board is incompatible with an 80387. Looks like there's some substance to those reports.

- I carefully followed Levco's instruction manual for installing the Prodigy board's accompanying software, but the installation disk's contents did not match what the manual led me to expect; specifically, a control desk-accessory file was missing from the floppy. Also, when I tried to run the RAM disk initialization (again, as outlined in the manual) a bomb box appeared. I finally discovered how to set up the Levco software by reading the "Get Info" information associated with the files on the floppy.

Results

First of all, it's easy to see that if your application is floating-point-intensive, then no matter which processor you choose, for heaven's sake, get a math coprocessor. The cost of coprocessors is still a bit high (often as much as or more than the CPUs that run them—as of this writing, you'll pay around \$300 for an 8-MHz 80287 and \$200 for a 12-MHz 68881). But if processing time is money, the coprocessor could easily pay for itself.

In the 68000/68020 arena, it's Definicon's DSI-780 that appears to win out. I say "appears" because the C compiler used with the Definicon board (Silicon Valley Software's C compiler) is necessarily different from the one I used on the Macintoshes (Consulair) and the Arete (its C compiler comes with Unix). Therefore, it is difficult to tell how much of the Definicon's advantage to attribute to the compiler. (Here's an example of a similar case: I also compiled the benchmarks using Lightspeed C version 2.01 on the Mac SE with Prodigy installed. Lightspeed C turned in figures that were 10 percent to 15 percent faster than Consulair's 68020 compiler—except for the floating-point benchmarks, which makes sense once you discover that Lightspeed C does not recognize the 68881.)

Table 1a: Benchmark figures for 68020 machines. All Macintosh benchmarks were generated using Consulair's C compiler version 5.04; I used the 68020 flavor of this compiler for all Macs except the SE. The Arete came with its own compiler. On the DSI-780, I used Silicon Valley Software's C compiler version 2.0.

Test	Mac SE	Mac SE with HyperCharger	Mac SE with Prodigy	Mac II	Arete	DSI-780
	Dhrystone	574	2176	2380	2106	2710
Fibonacci	263.54	71.60	71.45	83.72	69.86	47.89
Float	230.23	4.06	2.61	2.63	2.90	2.24
Savage	1921.00	8.86	5.22	5.42	24.70	5.65
Sieve	64.56	14.92	14.83	16.72	12.40	4.89
Sort	103.82	20.55	20.41	23.20	13.20	6.74

Table 1b: Benchmark figures for 80386 machines. I used MetaWare's HighC 386 compiler version 1.3 on all machines except the AT, on which simply used the same compiler with no 80386 support. Phar Lap's 386|LINK was the linker (again on all machines except the AT, for which I used Microsoft's LINK version 3.51). I used RUN386 version 1.1e for the 80386 machines (as required by HighC) except for the Model 80—see text for the reason.

Test	IBM PC AT 8-MHz 80287	Model 80 16-MHz 80387	Kaypro 386 No FPU	ALR 386/2 10-MHz 80287	Compaq 386 8-MHz 80287	Compaq 386 16-MHz 80387
	Dhrystone	1590	3626	3271	3283	3748
Fibonacci	126.22	57.26	64.65	64.66	53.12	53.11
Float	10.98	1.62	40.42	5.30	6.80	1.43
Savage	37.30	9.49	355.29	17.97	21.53	8.95
Sieve	24.60	6.45	6.81	7.41	5.99	5.98
Sort	43.17	7.74	8.35	8.55	5.58	5.58

If money's no object and you're out for raw power, a Compaq 386 with an 80387 installed is your best bet in 80386-land. The figures for the 80386 systems are probably more meaningful than those for the 680x0 machines, since I was able to run the same .EXE files on all the 80386 systems. (Of course, I couldn't do this for the AT; even so, at least the compiler on the AT was from the same company as the 80386 compiler—MetaWare.)

Overall, it appears that—and I know I'll catch a lot of flak for this—the 80386 machines outperform the 68020 machines. Of course, the reasons for this could well go beyond the possibility that one processor is simply faster than the other; I'm using different C compilers, the hardware is different, the subset of all the applications users can expect to run, and so on. But let's look at some facts: The C compilers I used were the only shipping 68020 and 80386 compilers available at the time I ran these

benchmarks (Manx's Aztec C 68020 compiler might be shipping by the time this issue reaches press, as might Computer Innovations' C86+ 80386 compiler—we'll include these in future New Generation stories), so, for now, these are the compilers available to you for your development work. Also, it makes no sense to benchmark the processors independently of the systems that incorporate them: You don't buy just a processor, you buy a complete system—and the systems I tested are the same ones you can buy. So what we're looking at are the hardware and software configurations that the world has made available to you so far. ■

[Editor's Note: The table in this article is a condensation of a vast array of benchmark figures that were compiled. For the complete set of figures—especially if you're interested in floating-point performance without an FPU—see the super-micro benchmark topic on BIX.]

3M data cartridge available in five

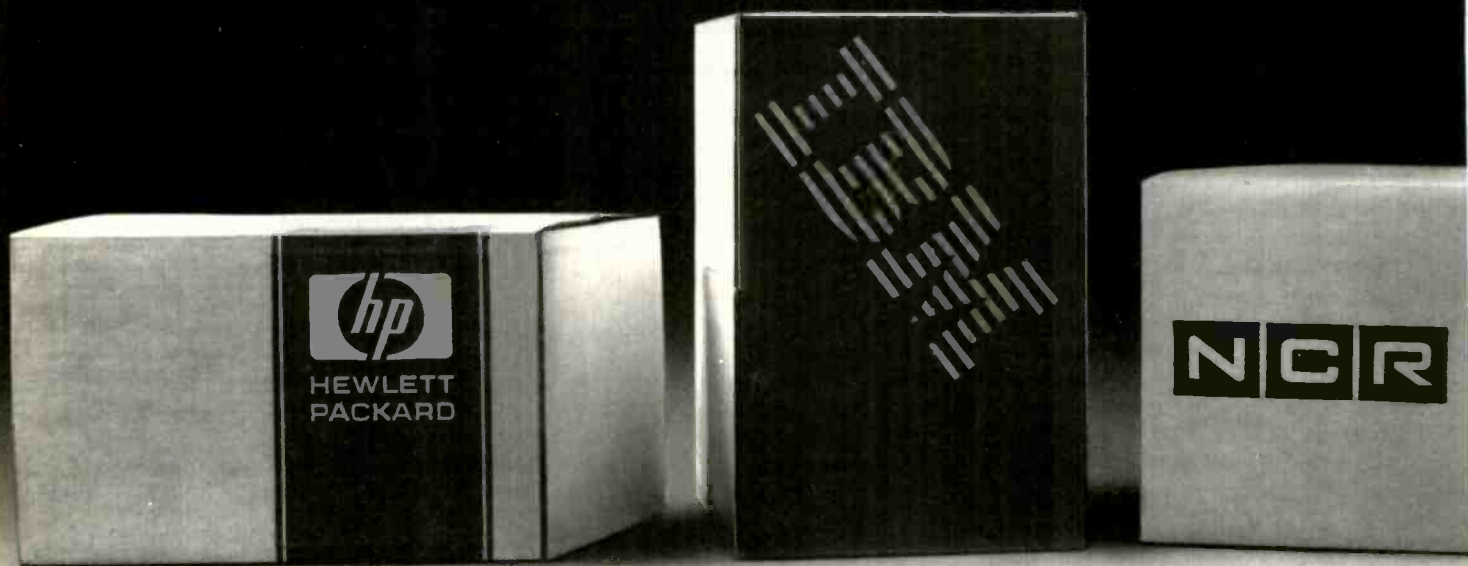

tape backup is now popular models.



The makers of even the most popular PCs know it's insane to go to market without a reliable backup.

So they each sat through hundreds of blank and scrambled screens to see which backup system backed up best.

In the end, they each chose 3M data cartridge tape technology.

Why?

We've been covering computer and human errors almost longer than computers and humans have erred together.

Not only did we patent data cartridge technology, we've had 16 years to make it better. Through every

technological breakthrough, we've proven to be the best way to back up data.

Just ask Apple.* And NCR.* And HP.* And IBM.* And COMPAQ.*

Call (800) 423-3280 for a list of data cartridge drive manufacturers.

Trademarks/owner: Apple/Apple Computer Inc.; NCR/National Cash Register; HP/Hewlett-Packard; IBM/International Business Machines Corp.; COMPAQ/COMPAQ Computer Corp.

©3M 1987

Inquiry 328



12 MHz SPEED!

For your PC, XT, AT
or compatible.

FastCACHE-286™ The Fastest PC Accelerator!

FastCACHE-286 is the fastest half card accelerator ever built. It is also the first to have an on-board 8088 socket, built-in high-speed 80287 clock, and software controlled slow and fast 80286 modes. FastCACHE-286 accelerates the IBM PC, XT and compatibles. It can be purchased in either a 9 or 12 MHz version starting at \$399 (9 MHz). The card combines the best features of our 286TurboCACHE™ (PC Magazine "Editor's Choice") with the ability to run asynchronously. This frees it from the 7.2 MHz frequency barrier of synchronous cache cards and enables the board to run on dual-speed motherboards and PCs such as the Zenith 158 or the Leading Edge Model D! The board includes MicroWay's DCache software and is compatible with all PC software and EMS, EEMS, and EGA.

	Sieve		Shuttle	Price
	SI	MS C (sec)	Regen (sec)	
PC	1.0	5.88	100 (12)*	-
9 MHz FastCACHE-286	7.1	1.32	28 (7)*	\$399
12 MHz FastCACHE-286	10.3	.93	22 (6)*	\$599

*Times in parentheses are with an 8087 or 80287.

287TurboPLUS™ Speeds Up your 80287 and your 80286!

287TurboPLUS adds a new feature to PC Magazine Editor's Choice - 287Turbo. 287Turbo increases 80287 speed from the 4 MHz used by IBM to 10 or 12 MHz. It has become an industry standard used in the AT, clones and the 386 Deskpro. 287TurboPLUS lets a user control the 80286 clock speed of the AT motherboard. Typical ATs will run up to 9 or 10 MHz. When used with 100 nsec DRAM and an optional high speed 80286 it is possible to get 11 MHz speed from an AT. 287TurboPLUS includes a 10 or 12 MHz tested 80287, 80287 diagnostic software and easily installs in your 80287 socket.

MICROWAY . . . Respected throughout the industry for high quality engineering, service and technical support.
Dealer, VAR, university and corporate inquiries are welcome.

Micro Way

The World Leader in 8087 Support

P.O. Box 79, Kingston, Mass. 02364 USA (617) 746-7341
32 High St., Kingston-Upon-Thames, England, 01-541-5466

FastCACHE-286, 287Turbo, 287TurboPLUS and 286TurboCACHE are trademarks of MicroWay, Inc. MicroWay is a registered trademark of MicroWay, Inc.

Steve Ciarcia

Part 1: AT Basics

Build the Circuit Cellar AT Computer

New chip technology lets Steve put an AT on a card



The personal computer industry can best be described as competitive and fast-moving. Hundreds of manufacturers around the world are turning out IBM PC, XT, and AT clones, as well as board products for those who wish to mix and match to build a desktop computer. Heavy competition forces these manufacturers to continually bring out higher performing products that are less expensive than their competitors' products. Talk about a dog-eat-dog business!

Ordinarily, given such market volatility, I would not stick my neck into the "clone wars," but I just couldn't pass up the opportunity to show some new technology that would one-up all these companies. The two-part project starting this month uses a set of four high-integration ZyMOS ICs that contain most of the peripheral chips needed to build an IBM PC AT. Using this advanced technology, I will present a faster, smaller, and more efficient 100 percent compatible AT CPU board called the CCAT (Circuit Cellar AT). With the addition of Award Software's AT BIOS, the CCAT and your imagination can configure an unbeatable (should I say uncloneable?) 80286 computer system.

Technology to the Rescue

The ZyMOS POACH (which stands for PC on a chip) set is really an ASIC (application-specific IC) set that was originally

Steve Ciarcia (pronounced "see-ARE-see-ah") is an electronics engineer and computer consultant with experience in process control, digital design, nuclear instrumentation, and product development. The author of several books on electronics, he can be reached at P.O. Box 582, Glastonbury, CT 06033.

developed to show just how much could be integrated on one 230-pin chip (it contained 22,000 logic gates). Eventually, it was divided into more cost-effective 84-pin devices (see photo 1).

ZyMOS uses standard-cell CMOS (complementary high-speed metal-oxide semiconductor) technology for its ASIC products. Some methods for developing ASICs are gate arrays, programmable logic arrays, and standard-cell technology, to name a few. Standard-cell technology produces chips that are highly integrated (they can squeeze 25,000 logic gates on a single device) but also very efficient in their use of silicon area.

Gate arrays are essentially a mass of predefined gates that are interconnected by the designer, but that most often leave a lot of unconnected gates and waste sili-

con. The standard-cell approach uses just the logic elements the designer requires. The result is higher densities of utilized gates requiring smaller die size. Less silicon means lower cost per device.

Standard cells are predefined logic units that correspond to commercially available devices like inverters, AND gates, flip-flops, and more complex parts (like the 82xxx peripheral chips used in the IBM PC AT).

A chip designer developing an IC first lays out a schematic, just as for any project. Such a schematic typically contains off-the-shelf components like 8254 counter-timers, 7474 flip-flops, 7408 AND gates, and 7432 OR gates. Next, the designer enters this schematic into a computer using specialized graphics soft-

continued

Photo 1: This section of the Circuit Cellar AT circuit board shows the POACH (PC on a chip) integrated circuits.

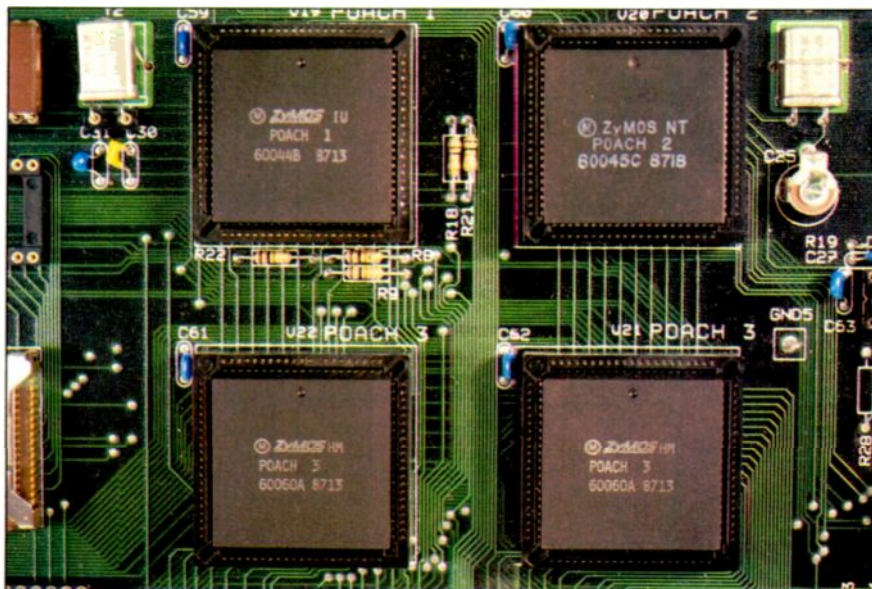

ware that generates a file called a *net list* (Circuit Cellar projects are currently done on Schema).

The net list defines which logic elements from a library of standard cells are needed and how those cells are interconnected. The net list is input to a logic simulator, which the designer uses to debug the design, and then fed to a program called a *router*. The router actually lays

out the final chip, transistor by transistor. Sounds easy! It's not—it's just easier and faster with the computerized tools. Even so, it took seven months to develop the four-chip POACH set used in the CCAT.

Understanding the AT's Design

Before we look closely at the POACH chips and the CCAT, we should get some understanding of the IBM PC AT mother-

board's design so we can better understand what it is that we are trying to improve. The AT is an Intel 80286 16-bit microprocessor design that can optionally support the 80287 math coprocessor for fast floating-point operations. It also uses an Intel 8742 microcontroller as a keyboard processor.

In addition to the processors, the AT uses 10 VLSI peripherals that work in

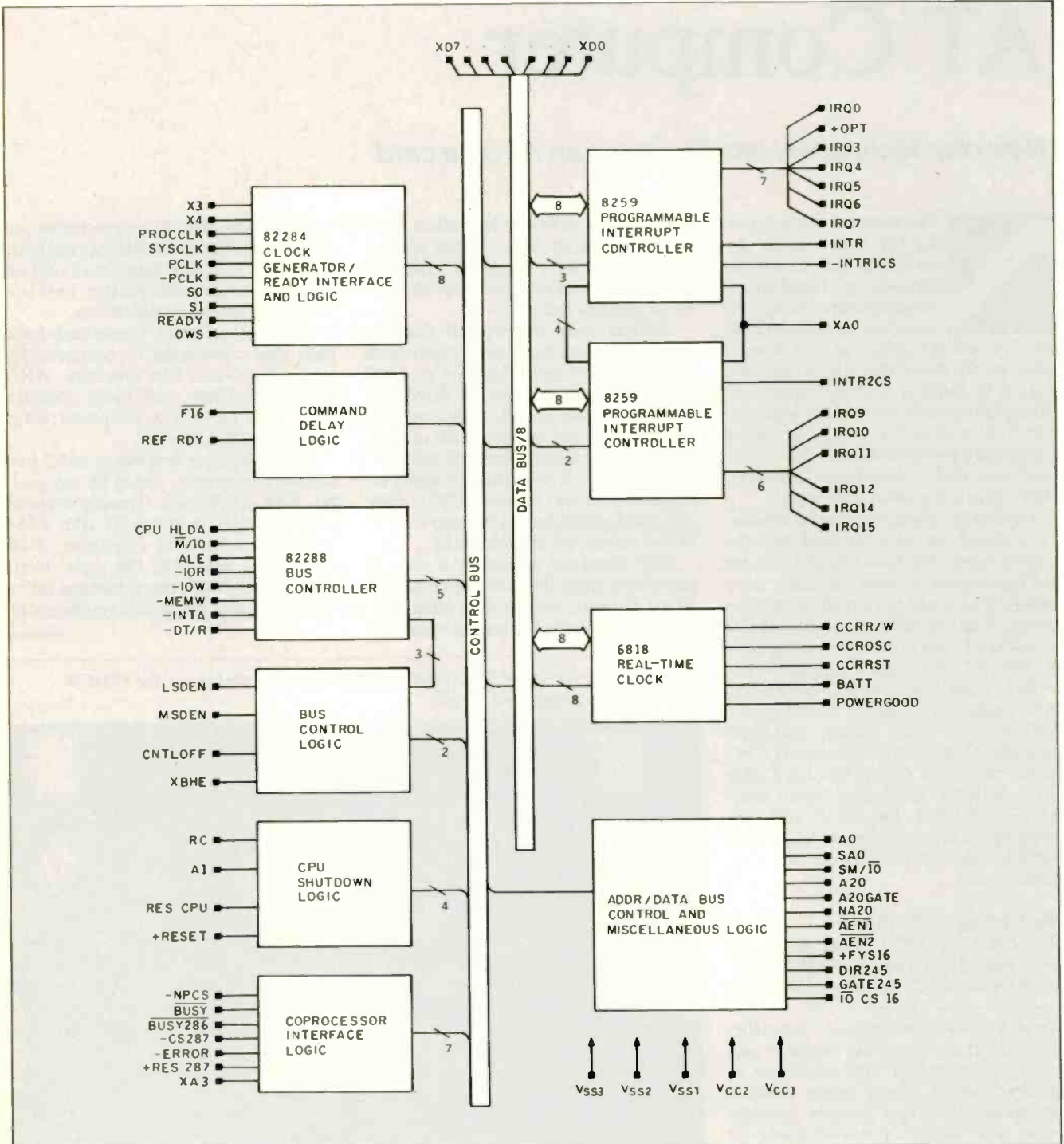

Figure 1: The block diagram of the internals of POACH1.

conjunction with the 80286 to perform functions like bus timing, interrupt control, and direct-memory-access operations. These devices integrate much necessary logic that a designer would ordinarily have to build up from primitive logic functions to get a design to perform properly. They are the building blocks that, with integrated microprocessors, have shrunk the computer's physical size and made prices affordable.

The peripherals in the AT include two 8259A programmable interrupt controllers, an 82284 clock generator and ready interface, an 82288 bus controller, a 6818 clock/calendar/RAM, two 8237A DMA controllers, a 74LS612 memory mapper, an 8284 clock generator, and an 8254 programmable interval timer.

The interrupt controllers sort out and prioritize interrupt requests to the microprocessor. Each interrupt controller can handle up to eight interrupts, but Controller-2 (CTLR2) interrupts are directed through CTLR1, which uses up one of CTLR1's interrupt lines. Interrupt requests (IRQ) are mapped as shown in table 1. The 82288 and 82284 perform general system clocking, some decoding of 80286 control signals, and bus-control functions in the AT.

The 6818 contains the clock/calendar and 64 bytes of CMOS RAM. The clock function uses 14 bytes of the RAM to hold time and date data. The rest of the RAM holds the system's configuration information, like the type of floppy and hard disk drives and low- and high-memory bytes. The 6818 is kept alive when the machine is powered down with battery power and a continually running clock frequency.

The two 8237As provide seven DMA channels. DMA CTLR1 supports 8-bit data transfers between 8-bit I/O adapters and 8- or 16-bit system memory. Data transfers can occur throughout the 16-megabyte address space in 64K-byte blocks. DMA CTLR2 supports 16-bit data transfers between 16-bit I/O adapters and 16-bit memory and can perform data transfers in 128K-byte blocks throughout the full 16-megabyte address range. Since the DMA controllers generate only 16-bit addresses, the system uses the LS612 memory mapper to extend the addressing to 16 megabytes.

A 14.318-megahertz crystal drives the 8284 clock generator. The 14.318-MHz clock is routed directly to the expansion slots.

The 8254 programmable interval timer provides 16-bit counters on three independent channels. Channel 0 produces the system timer signal (18 ticks per second), channel 1 generates the dynamic RAM-refresh request, and the system

Table 1: Request mapping for the interrupt controllers on the CCAT.

CTLR1	CTLR2	
IRQ0		Timer output 0
IRQ1		Keyboard (output buffer full)
IRQ2		Interrupt from CTLR2
	IRQ8	Clock/calendar/RAM
	IRQ9	Software redirected to INT 0AH (IRQ2)
	IRQ10	Reserved
	IRQ11	Reserved
	IRQ12	Reserved
	IRQ13	Coprocessor
	IRQ14	Fixed disk controller
	IRQ15	Reserved
IRQ3		Serial port 2
IRQ4		Serial port 1
IRQ5		Parallel port 2
IRQ6		Disk controller
IRQ7		Parallel port 1

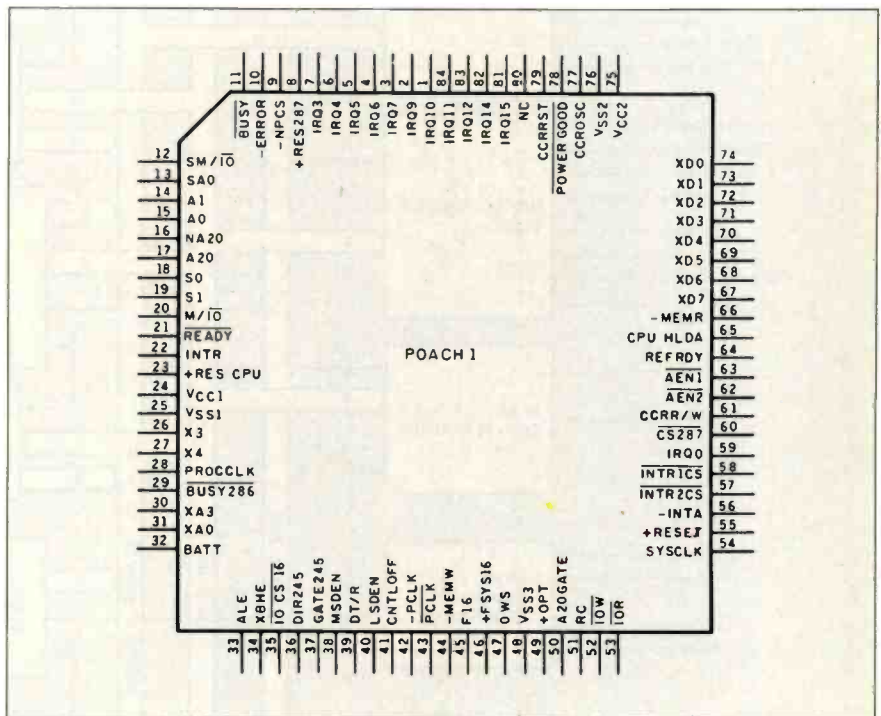

Figure 2: A pin-out diagram for the POACH1 chip.

uses channel 2 for the speaker's tone generator.

You should begin to see some of the characteristics of the AT emerging. It is a 16-bit interrupt-driven system with DMA capability for fast memory data transfers. The PC's speaker is still there to prompt you with those annoying beeps and to add some dimension to game playing. And we've added a real-time clock to keep track of time and date.

If we tack on 512K bytes of DRAM and a couple of ROMs to hold the BIOS, the system starts taking form. It would be

great if we could stop here, with about 43 chips making up the system. But we have to glue all this together and provide a means for the processor to talk to memory and the outside world—so we have address and data buses.

The AT has a number of address and data buses, with many buffers, latches, and multiplexers separating the individual buses. In fact, it has five distinct buses: local, system, X, memory, and L address. (The first four have both address and data components.)

continued

The local address and data buses are tied directly to the 80286 and 80287. Twenty-four address lines and 16 data lines form the heart of the AT. The address lines are latched by three LS573s that buffer the local address bus from the system address bus. Because the 80286 can do word and byte data transfers, and word transfers need not be aligned, the

AT data-bus interface has to differentiate between the high-bus byte and the low-bus byte. ("Aligned" refers to the fact that the word address is even, that is, A0 = 0).

If the system has to transfer a word over the bus to an odd address location, it requires two bus cycles—one to transfer the low byte and one to transfer the high byte

(this is a nonaligned word transfer). The local data bus is separated from the system data bus by an LS245 buffer and an LS646, which not only buffers but also has a latch function.

The system address and data buses are the primary ones in the AT for both memory and I/O transfers, including the interface to the AT's expansion slots. The sys-

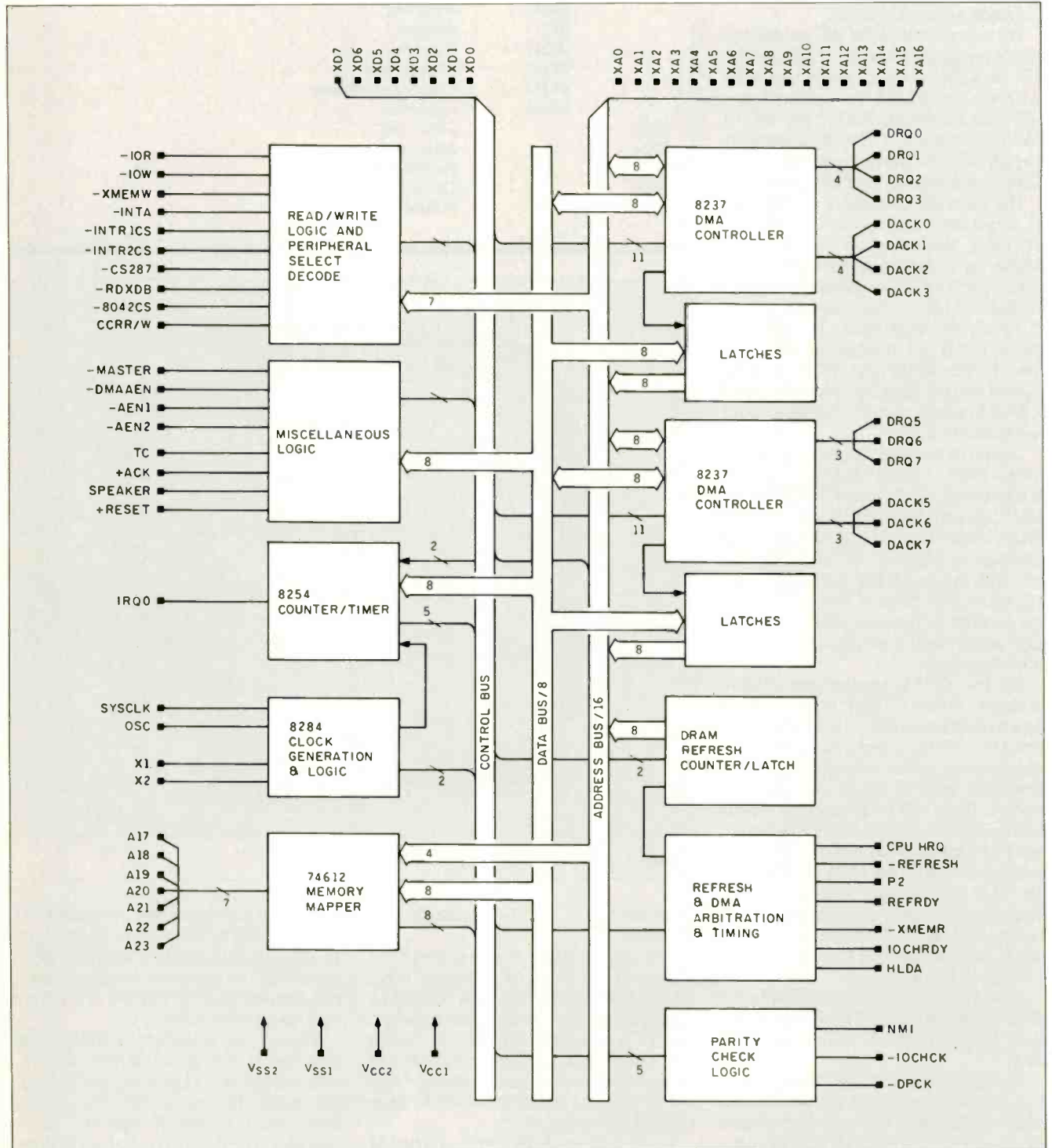

Figure 3: The block diagram of POACH2.

tem address bus is a latched 20-bit (SA0 through SA19) version of the 80286 local address bus. The system data bus maintains the low-byte and high-byte reference. The AT performs 16-bit transfers for memory and expansion data, but it does 8-bit data transfers for the X bus (which the AT motherboard uses to communicate with the 80286 peripheral chips).

The X address bus is a 17-bit bus that you can think of as private to the motherboard. The system uses this bus to address ROM (where the BIOS is kept) and motherboard I/O, as well as to generate addresses for DMA- and RAM-refresh operations. It is separated from the system address bus by LS245s.

The X data bus interfaces to functions like DMA controllers, interrupt controllers, the keyboard processor, and the clock/calendar/RAM hardware. Although the system uses the X address bus to select ROM data, this data is fed to the processor via the memory data bus, not the X data bus.

The memory address and data buses apply to DRAM on the motherboard. The 9 address lines (MA0 through MA8) of the memory address bus are a multiplexed version of 18 system-address lines. The memory data bus is a 16-bit motherboard bus that interfaces both DRAM and ROM.

The L address bus, hangs like an appendage off the local address bus. It is an unlatched 7-bit (LA17 through LA23) address that is always available except when an I/O processor gains control of the system. The L address bus gives the AT a 16-megabyte address range.

Complicated? You bet! We've just added 83 ICs for buffering, additional logic, and glue to tie the system together. This brings the total IC count for a 512K-byte system to 126 packages. Now you can see why the motherboard is approximately 14 inches square!

Microcomputers did not always have big motherboards. Originally, when they were much simpler, they used passive backplanes, with the processor board plugged into one of the backplane slots. Chip count and board size have an obvious effect on the cost of the system. That's where the new high-integration chips play such an important role.

The POACH Set

The engineers at ZymOS partitioned the motherboard's logic into a set of 84-pin ICs. Two chips, POACH1 and POACH2, contain *all* the 82xxx-series peripherals and also some key logic. POACH1 is primarily responsible for system clocking and bus control (see figures 1 and 2). It contains the 8259A interrupt controllers,

the 82284 clock generator and ready interface, the 82288 bus controller, and the 6818 clock/calendar/RAM. All the buffers and latches in the system are controlled by POACH1.

POACH2, shown in figure 3, controls the X address bus for DMA and refresh operations. It contains the two DMAs, the 74LS612 memory mapper, refresh logic, the 8284 clock generator, and the 8254 programmable interval timer. Figure 4 shows POACH2's pin-out diagram.

The buffers, latches, and remaining logic are in POACH3, the buffer chip. (I haven't provided a block diagram for POACH3 since it's simply a mass of uninteresting discrete logic.) POACH3 is mode-programmable, and we've used two in the CCAT, one for address buffering and the other for data buffering. I'll refer to the device set for address-buffering mode as POACH3-A and the device set for a data buffer as POACH3-D.

The AT POACH set brings the total IC count for a 512K-byte AT-compatible motherboard equivalent down to 23 IC packages and two SIMMs (single in-line memory modules).

Ultimately, our design is intended to be totally IBM compatible, with certain key advantages. Using the POACH chips, we can squeeze the whole motherboard into an AT expansion board with room to spare and build a system on a passive backplane. Since all the usual power-hungry ICs are now incorporated in the POACH devices (the four-chip set needs

The POACH set brings the total chip count for a 512K-byte AT compatible down to 23 IC packages and two SIMMs.

less than 100 milliamperes), we will also be able to construct a low-power AT.

Next Month

I'll complete this project with a full schematic and a detailed description of the Circuit Cellar AT computer. ■

The CCAT was a joint venture, and I'd like to note the contributions and help from ZymOS, Micromint Inc., Award Software Inc., and the Circuit Cellar research staff. In addition, I'd like to personally thank Bob Andrews, Jeff Bachiochi, and Jeff Remmers for their efforts.

Editor's Note: Steve often refers to previous Circuit Cellar articles. Most of these past articles are available in book form from BYTE Books, McGraw-Hill Book Company, P.O. Box 400, Hightstown, NJ 08250.

Ciarci's Circuit Cellar, Volume I covers continued

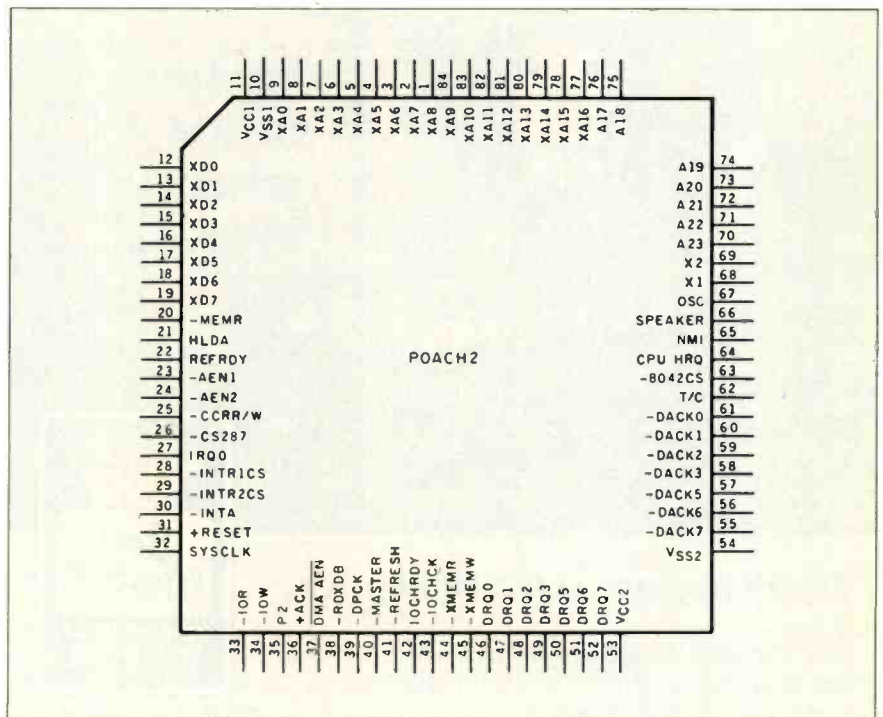

Figure 4: POACH2's pin-out diagram.

Attention all FX80, FX100, JX, RX, & MX owners:
**You already own half of
 a great printer**



**Now
 Only
 \$79.95**

Now for \$79.95 you can own the rest. You see, today's new dot matrix printers offer a lot more.

Like an NLQ mode that makes their letters print almost as sharp as a daisy wheel. And mode switching at the touch of a button in over 160 styles. But now, a Dots-Perfect

upgrade kit will make your printer work like the new models in minutes— at a fraction of their cost.

And FX, JX and MX models will print the IBM character set, too.

So, call now and use your Visa, MasterCard, or AmerEx. Don't replace your printer, upgrade it!

1-800-368-7737

(Anywhere in the United States or Canada)

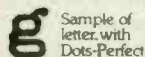

Dots-Perfect™

Dresselhaus

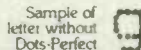

8560 Vineyard Ave., Ste. 405, Rancho Cucamonga, CA 91730

(714) 945-5600

An upgrade kit for EPSON FX, JX, RX, & MX printers

IBM is a registered trademark of International Business Machines Corp. Graftraz PLUS is a trademark of Epson America, Inc. Epson is a registered trademark of Epson America, Inc.

CIRCUIT CELLAR

articles in BYTE from September 1977 through November 1978. *Volume II* covers December 1978 through June 1980. *Volume III* covers July 1980 through December 1981. *Volume IV* covers January 1982 through June 1983. *Volume V* covers July 1983 through December 1984.

The following items are available from

Micromint Inc.
 4 Park St.
 Vernon, CT 06066
 (800) 635-3355 (orders)
 (203) 871-6170 (information)
 Telex: 643331

1. Assembled and tested CCAT 80286 PC AT-compatible CPU board with 512K bytes of RAM, Award BIOS in ROM, and user's manual. Available in 8 MHz or 10 MHz.
 8 MHz, order OEM286LP/8\$775
 10 MHz, order OEM286LP/10\$825
2. Assembled eight-slot AT-style passive backplane with all connectors.
 order MBAT/8\$115

The following items are available from

CCI
 P.O. Box 428
 Tolland, CT 06084
 (203) 875-2751

1. CCAT/POACH developer's kit. Contains six-layer CCAT PC board, four POACH chips, Award BIOS ROMs, preprogrammed 8742 keyboard controller, PROM, and user's manual. (This developer's kit is scheduled to be available through January 15, 1988.)
 order CCAT/DEV\$475
2. Bare, unpopulated AT-style passive backplane PC board.
 order MBAT/0\$35

POACH chips and BIOS ROMs are available. Call for price and delivery information.

For either source above, all payments should be made in U.S. dollars by check, money order, MasterCard, Visa, or American Express. Surface delivery (U.S. and Canada only): add \$5 for U.S., \$8 for Canada. For delivery to Europe via U.S. airmail, add \$14. Three-day air freight delivery: add \$10 for U.S. (UPS Blue), \$25 for Canada (Purolator overnight), \$45 for Europe (Federal Express), or \$60 for Asia and elsewhere in the world (Federal Express).

There is an on-line Circuit Cellar bulletin board system that supports past and present projects. You are invited to call and exchange ideas and comments with other Circuit Cellar supporters. The 300/1200/2400-bps BBS is on-line 24 hours a day at (203) 871-1988.

To be included on the Circuit Cellar mailing list and receive periodic project updates and support materials, please circle 100 on the Reader Service inquiry card at the back of the magazine.

What is a Best Western?



“My home office wherever I travel.”

The right place at the right price.

Make reservations at any Best Western, see your travel agent, or call toll-free
1-800-528-1234



World's largest chain of independently owned and operated hotels, motor inns and resorts™

E=M

AZTEC

Our thanks to NASA for supplying this computer enhanced ultraviolet photo taken by Skylab IV of a solar prominence reaching out 350,000 miles above the sun's surface

Genius Begins With A Great Idea ...

But The Idea Is Just The Beginning

What follows is the time consuming task of giving form and function to the idea.

That's why we concentrate on building into our software development systems functions and features that help you develop your software ideas in less time and with less effort.

We've started 1987 by releasing new versions of our MS-DOS, Macintosh, Amiga, ROM, and Apple II C development systems. Each system is packed with new features, impressive performance, and a little bit more genius.

FREE 2 DAY DELIVERY

Aztec C86 4.1 New PC/MS-DOS • CP/M-86 • ROM

Superior performance, a powerful new array of features and utilities, and pricing that is unmatched make the new Aztec C86 the first choice of serious software developers.

Aztec C86-p Professional System . . . \$199

• optimized C with near, far, huge, small, and large memory + Inline assembler + Inline 8087/80287 + ANSI support + Fast Float (32 bit) + optimization options • Manx Aztec 8086/80x86 macro assembler • Aztec overlay linker (large/small model) • source level debugger • object librarian • 3.x file sharing & locking • comprehensive libraries of UNIX, DOS, Screen, Graphics, and special run time routines.

Aztec C86-d Developer System . . . \$299

• includes all of Aztec C86-p • Unix utilities make, diff, grep • vi editor • 6+ memory models • Profiler.

Aztec C86-c Commercial System. . . \$499

• includes all of Aztec C86-d • Source for library routines • ROM Support • CP/M-86 support • One year of updates.

Aztec C86 Third Party Software

A large array of support software is available for Aztec C86. Call or write for information. The following is a list of the most requested products: • Essential Graphics • C Utility Library • Curses • Greenleaf Communication, General, and Data Window • Halo • Panel+ • PC-lint • PforCe • Pre-C • Windows for C • Windows for Data • C terp • db_Vista • db-Query • Phact • Plink-86 Plus • c-tree • r-tree • Pmate.

CP/M • TRS-80 • 8080/Z80 ROM

C compiler, 8080/Z80 assembler, linker, librarian, UNIX libraries, and specialized utilities.

Aztec C II-c (CP/M-80 & ROM) \$349

Aztec C II-d (CP/M-80) \$199

Aztec C80 (TRS-80 3&4) \$199

Aztec C68k/Am 3.4 New Amiga Release

Amiga user groups across the USA voted Aztec C68k/Am release 3.3 the best Software Development System for the Amiga. Release 3.4 is more impressive.

Aztec C68k/Am-p Professional \$199

A price/feature/performance miracle. System includes: optimized C • 68000/680x0 assembler • 68881 support • overlay linker • UNIX and Amiga libraries • examples.

Aztec C68k/Am-d Developer \$299

The best of Manx, Amiga, and UNIX. System includes: all of Aztec C68k/Am-p • the Unix utilities make, diff, grep and vi.

Aztec C68k/Am-c Commercial \$499

Aztec C68k/Am-d plus source for the libraries and one year of updates.

FREE 2 DAY DELIVERY

Aztec C68k/Mac Macintosh • New Release 3.4

For code quality, reliability, and solid professional features, Aztec C for the Macintosh is unbeatable. This new release includes features and functions not found in any other Macintosh C development system.

Aztec C68k/Mac-p Professional . . . \$199

• MPW source level compatibility • TMON, MACSBUG, and MACNOSY support • powerful symbolic debugger • optimized C • 68000/680x0 assembler • 68881, IEEE, and SANE support • overlay linker • UNIX and Macintosh libraries • mouse editor • examples.

Aztec C68k/Mac-d Developer . . . \$299

The best of Manx, Macintosh, and UNIX. System includes: all of Aztec C68k-p • Profiler • the UNIX utilities make, diff, grep • vi editor.

Aztec C68k/Mac-c Commercial . . . \$499

Aztec C68k/Am-d plus source for the libraries and one year of updates.

Aztec C65 New ProDOS Release

Aztec C65 is the only commercial quality C compiler for the Apple II. Aztec C65 includes C compiler, 6502/65C02 assembler, linker, library utility, UNIX libraries, special purpose libraries, shell development environment, and more. An impressive system.

Aztec C65-c Commercial \$299

• runs under ProDOS • code for ProDOS or DOS 3.3

Aztec C65-d Developer \$199

• runs under DOS 3.3 • code for DOS 3.3

Aztec ROM Systems

6502/65C02 • 8080/Z80 • 8086/80x86 • 680x0

An IBM or Macintosh is not only a less expensive way to develop RCM code, it's better. Targets include the 6502/65C02, 8080/Z80, 8086/80x86, and 680x0.

Aztec C has an excellent reputation for producing compact high performance code. Our systems for under \$1,000 outperform systems priced at over \$10,000.

Initial Host Plus Target \$750

Additional Targets \$500

ROM Support Package \$500

Vax, Sun, PDP-11 ROM HOSTS

Call for information on Vax, PDP-11, Sun and other host environments.

C' Prime PC/MS-DOS • Macintosh Apple II • TRS-80 • CP/M

These C development systems are unbeatable for the price. They are earlier versions of Aztec C that originally sold for as much as \$500. Each system includes C compiler, assembler, linker, librarian, UNIX routines, and more. Special discounts are available for use as course material.

C' Prime \$75

Aztec Cross Development Systems

Most Aztec C systems are available as cross development systems. Hosts include: PC/MS-DOS, Macintosh, CP/M, Vax, PDP-11, Sun, and others. Call for information and pricing.

How To Become An Aztec C User

To become a user call 800-221-0440. From NJ or international locations call 201-542-2121. Telex: 4995812 or FAX: 201-542-8386. C.O.D., VISA, MasterCard, American Express, wire (domestic and international), and terms are available. One and two day delivery available for all domestic and most international destinations.

Aztec C is available directly from Manx and from technically oriented computer and software stores. Aztec Systems bought directly from Manx have a 30 day satisfaction guarantee.

Most systems are upgradable by paying the difference in price plus \$10. Site licenses, OEM, educational, and multiple copy discounts are available.

To order or for more information call today.

1-800-221-0440

In NJ or international call (201) 542-2121 • TELEX: 4995812



Inquiry 165

Manx Software Systems
1 Industrial Way, Eatontown, NJ 07724

MS is a registered TM of Microsoft, Inc. CP/M TM DRH, HALD TM Media Cybernetics, PANEL TM Roundhill Computer Systems, Ltd. PHACT TM PHACT Assoc. PRE-C Plink-86 + P-Force TM Phoenix, db Vista TM Rains Corp. C-teep PC-Int TM Gimpel Software, C-tree TM Faircom, Inc. Windows for C, Windows for DATA TM Creative Solutions, Apple II, Macintosh TM Apple, Inc. TRS-80 TM Radio Shack, Amiga TM Commodore Int'l, Unix TM AT&T, Vax TM DEC, Aztec TM Manx Software Systems

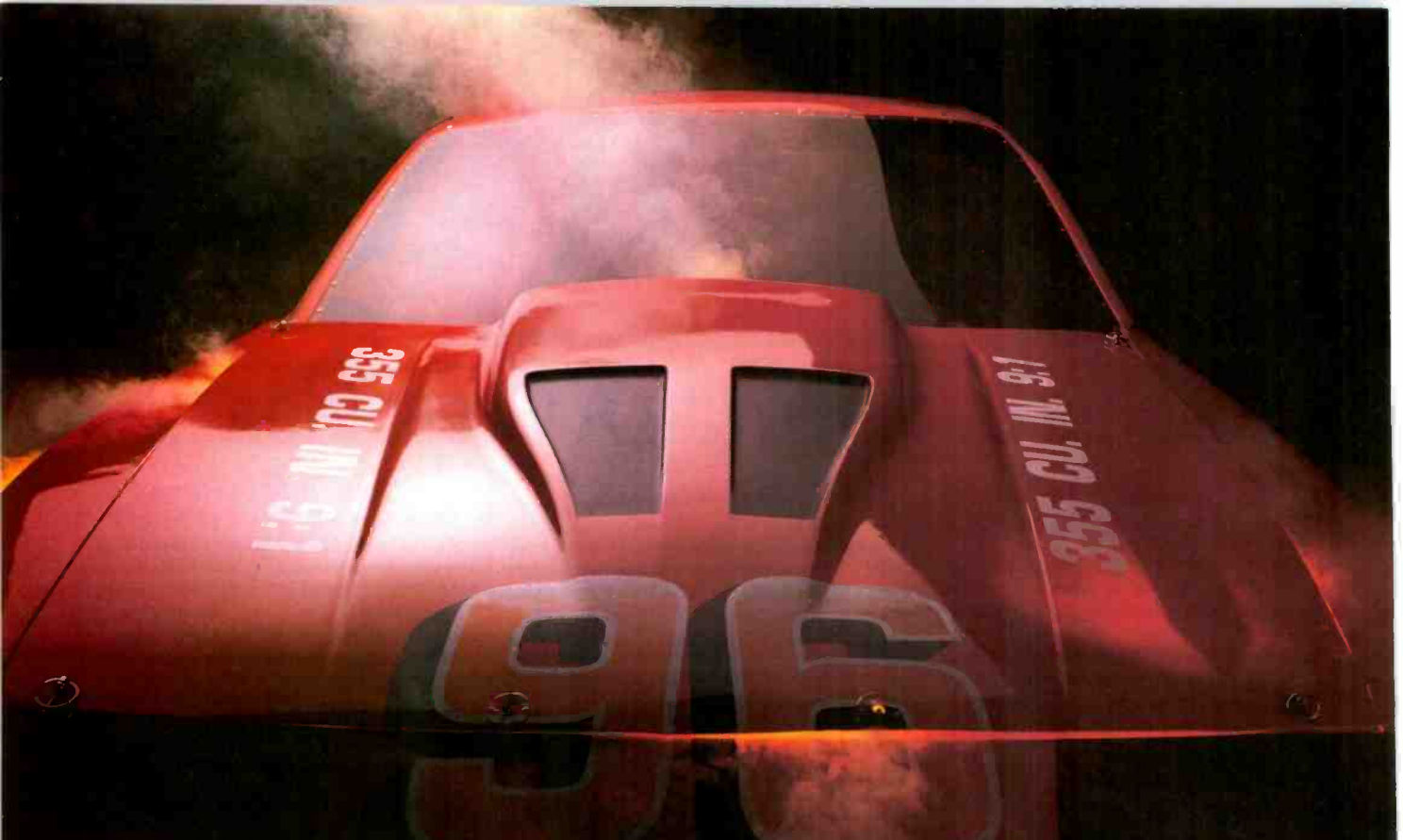

We designed our V.32 modem on the premise that speed is useless without reliability.

At Codex, we understand that all the speed in the world won't get you anywhere if you can't depend on it. And that's why we developed our V.32 modem to give you 9600 bps full-duplex dial transmission, rivalling the reliability of a dedicated leased line.

Admittedly a pretty big claim.

But then, it's really what you'd expect from the recognized leader in high speed modems. In fact, more data communications professionals prefer Codex than any other brand.* And it's our high speed modem expertise that has allowed us to make a modem that not only meets, but exceeds the V.32 standard.

Our V.32 modem uses the same VLSI technology and forward error correction scheme (Trellis Coded Modulation) as our high speed leased line modems that reliably transmit data up to 19,200 bps.

So, you can be sure of continuous high quality transmission over a wide range of line conditions. Visit Codex at TCA September 29-October 2, booth #228-231.

This now allows you to cut connect time and save money by sending data at up to 9600 bps full duplex over ordinary dial lines.

We've even added a proprietary long haul echo cancellation feature, eliminating both local and distant echoes that can plague dial networks. So even if the phone company sends your data over satellite links, it arrives intact.

Plus our V.32 modem includes a soft strap front panel, multiple ACUs, a nest card option for maximum space savings, and operates in synchronous or asynchronous applications.

To find out more about the Codex V.32 modem, call 1-800-426-1212, Ext. 235. Or write Codex Corporation, Dept. 707-35, 7 Blue Hill River Road, Canton, MA 02021-1097. You'll discover that when we tell you about a V.32 with high speed performance and reliability, we're not blowing smoke.



codex
MOTOROLA

*McGraw-Hill's Data Communications Brand Preference study cites Codex as offering the best technology, best price performance ratio, best service organization, and most informative literature for various modem, multiplexer and network control product categories. © 1986 Codex Corporation. Motorola and M are trademarks of Motorola, Inc. Codex is a registered trademark of Codex Corporation.

Hanna Oktaba and René Berber

Crafting Reusable Software in Modula-2

Careful program design results in safe, reusable program libraries



Programmers are constantly being called upon to produce more and more software, and their productivity continues to be an increasingly pressing problem. One way to boost programmers' productivity is to design reusable software—software that is standardized in some way so that the programmer can use it in a later situation instead of writing new but similar code. If you begin designing your programs in a way that produces small, reusable units of code, you will eventually build up a library of code modules that you can draw from to speed up the design and coding of new programs.

Unfortunately, software seems to resist efforts to make it more manageable. Sorting a set of strings, for example, is different enough from sorting a list of numbers that writing new code from scratch seems simpler than trying to adapt an existing routine. One way to make software reusable is to try to separate the algorithm from the data structures it uses. If you can do this, you need to design, code, and debug the algorithm only once, adding only a few data-related routines to implement the algorithm in a new context.

In the case of a sorting routine, you would try to design it so that it takes as parameters an array of objects to be sorted and a procedure that defines which of two elements comes before the other. This is called *parameterized programming* because the elements that distinguish one occurrence of the routine are passed as parameters to it.

To support parameterized programming, a programming language needs to provide you with certain facilities. An article by Joseph Goguen (see reference 1) lists those facilities and explains how they

are used. Such languages include Ada, with packages and generic packages; C, with the use of libraries; and Modula-2, with its modules and opaque-type declarations.

Modula-2 and Reusable Software

The programming language Modula-2 (see reference 2) has several constructs that support the crafting of reusable software. This language is readily available on many microcomputers, and for that reason we think it is important to promote its use for the design of reusable software.

In Modula-2, the basic concept of a *module* is, in an intuitive way, used to encapsulate pieces of software that make a logical unit in themselves—for example, an I/O package. There are several kinds of modules: program modules, local modules, and library modules. From here on, we will refer only to library modules.

Library modules are made out of two parts: a *definition* part and an *implementation* part. [Editor's note: *Since these units of code begin with the phrases DEFINITION MODULE... and IMPLEMENTATION MODULE..., they too are called modules, but we will use the word "part" wherever possible to refer to these two parts that, together, completely define a library module.*] The definition part contains a description of everything a module exports. This includes any constants or variables, the data types manipulated by the module, and the procedures that operate on them. A procedure description shows only its name, the name and type of its formal parameters, and, if it returns a value, the data type it returns.

The implementation part contains the implementation details (i.e., the actual code) of the procedures described in the definition part. It also contains auxiliary

procedures, variables, module-initialization code, and anything not exported but needed for the implementation. Sometimes the definition part declares, but does not define, data types (which are called *opaque* types because client modules cannot "see" the implementation details). In such a case, the implementation part defines the opaque type, but the details of the data structure are restricted to the implementation part itself.

Several concepts of Modula-2 promote the design methodology of reusable software. The most important are:

- *Separate compilation of modules.* This permits the creation of module libraries, ready to be reused as many times as needed. Also, the structure of Modula-2 lets you change and recompile the implementation part of a module without recompiling its definition part or any other library modules that depend on it.
- *Import lists.* These allow modules to use exportable procedures and data structures from other modules. This lets you use modules as building blocks in the construction of complex systems.
- *Opaque types.* When a module contains an opaque data type and all the proce-

continued

Hanna Oktaba has a Ph.D. in mathematics from Warsaw University, Poland, and teaches computer science at the graduate level at the Instituto de Investigaciones en Matemáticas Aplicadas y en Sistemas de la Universidad Nacional Autónoma de México. Dr. Oktaba can be reached at IIMAS-UNAM, APDO Postal 20-726, Deleg. Alvaro Obregón, 01000 México, D.F., México. René Berber has a B.S. in chemical engineering from UIA, México and is now working on his master's degree in computer science. He can be reached at Cádiz Norte 31, 03740 México, D.F., México.

dures needed to manipulate it, client modules can manipulate variables of that data type without knowing how the data is represented internally. To create reusable software via parameterized modules, you define an opaque data type and then create a generic routine that passes as arguments the procedures that will tell the routine how to interact with the data type. (In the case of the sorting example, you would pass a procedure that would tell the generic sort routine how to judge which of two elements comes first.)

- *Procedure types.* Modula-2 allows variables to hold values of type "procedure," thus allowing procedures to be passed as argument variables into another procedure.

- *Open arrays.* A program can pass an open array by name into a procedure without knowing its size at compile time. (Pascal, for example, can't do this.) This capability increases Modula-2's flexibility in writing procedures to manipulate arbitrary arrays of data.

Design Methodology for Parameterized Modules

You can use the following steps to create a parameterized module. As with any programming methodology, this is not a fixed procedure to follow, but it includes the important points you should look out for, and, with some experience, you would use to create reusable software.

- Analyze the system you are designing to see if any of its parts might be useful in other systems. If this is so, you have found a reusable part.

- See if you can design the reusable part so that it can pass the data type and, if possible, the procedures that manipulate it as parameters. An example of this is a FIFO (first-in/first-out) queue handler in which the type of elements manipulated is a parameter to the module. In such a case, you can change the type of elements stored in the queue without altering the operations that store or take out elements.

- To build the reusable package, define two modules: one for the opaque definition of the new data type and the procedures that manipulate it, and another for the procedures that use the new data type opaquely to get the real work done. (Remember that each of these modules will have both definition and implementation parts.) The definition part of the second module needs only to import the opaque data type and the procedures associated with it.

- The opaque data type and its procedures are actually defined in the implementation part of the first module. This implementation either defines the data type (if you use it here only) or imports it from another module (if you make it

available to other modules as well). In either case, you should actually implement the opaque data type visible outside the first module as a *pointer* to the data type that you need.

Both parts of the second module, along with the definition part of the first module, can be compiled and stored in a library of reusable modules. When a similar application arises that needs the same operation performed on a different data type, then you can reuse these modules; you will need to rewrite only the implementation part of the first module (i.e., the opaque data type and its procedures).

An Example

To illustrate how to apply this method, let's analyze an example that follows all the steps just described.

Suppose you are designing a file system, and one of the operations your clients require is sorting file descriptors of disk directories alphabetically by filename. After some thought, you realize that the sort operation is general enough to apply to several situations; in particular, to finite sequences of any data type, as long as the data type has defined for it an ordering operation " $< =$ ", and this operation satisfies the properties of *total order* (see the comments of listing 1 for a definition of total order). From this, you decide that you can parameterize your sort operation using an arbitrary data type (let's call it ElemType) and a procedure called compare that implements the " $< =$ " function.

Now, to do the actual programming in Modula-2, you must first code the definition part of the module that describes the formal type parameter ElemType and the compare procedure. Let's call this module SortElemType; listing 1 shows its definition part. [Editor's note: *Enhanced, ready-to-run versions of listings 2, 3, 5, 6a, and 6b are available under the names SORT.DEF, SORT.MOD, SORTTEST.MOD, SORTELEM.DEF, and SORTELEM.MOD on disk, in print, and on BIX; see the insert card following page 256 for details. These programs run under version 2.0 of Logitech's Modula-2. Listings are also available on BYTE-net; see page 4.]*

The definition module of SortElemType provides an interface for a sort module, declaring ElemType as the data type to be manipulated. By making this an opaque type, you can isolate its actual definition to the implementation part of this module. ElemType is followed by the description of the compare procedure, which is a Boolean relation that gives the ordering over elements of type ElemType. Unfortunately, there are no tools in Modula-2 definition modules to express

what a procedure does, so we have documented this in a comment statement.

Next, write the definition part of Sort, the module that gets the real work done using the data type ElemType (see listing 2). Note that this module imports both ElemType and compare and exports QuickSort, an implementation of the algorithm developed by C. A. R. Hoare. [Editor's note: *Compilers that implement the most recent definition of Modula-2 as defined in reference 2 do not need to use EXPORT QUALIFIED statements in definition modules; if they are included, they are treated as comments.*] The procedure's formal parameter is an open array, which makes it possible for it to sort arrays of different sizes.

Listing 3 is the implementation part of the Sort module; the implementation of QuickSort is adapted from Nicklaus Wirth's recursive implementation (see reference 3). All the QuickSort procedure does is define a local procedure, Sort, and then call it. Modula-2 uses the built-in function HIGH(A) to find the upper bound of the open array A. Just because the formal array argument A is indexed from 0 to HIGH(A) (open arrays *must* be indexed in this way), the actual array given to QuickSort is not restricted to that set of index limits.

The two definition parts and this implementation part in listings 1 through 3 comprise our reusable sort module. You can compile them (doing the definition modules first) and store them together for later use.

Now, getting back to the task of sorting the list of files alphabetically by name, you need to code the implementation part for the SortElemType module (see listing 4). In this module, you must either specify or import the actual data type needed and implement the compare procedure used to define the alphabetic ordering.

This implementation defines ElemType as a pointer to records of type FileDescr; if you don't import FileDescr from another module (as it is not here), then this module is the only part of the system that knows what constitutes the manipulated data.

Procedure compare expresses the " $<$ " relation of descriptors, taking into account the alphabetical order of its field, name. The procedure StringComp, which properly belongs to a module that implements string operations, is an auxiliary function used to compare any two strings. In it, you see again the use of open arrays as formal parameters, conforming to the agreed-upon convention in Modula-2 of the data type "string" as an array of any number of characters with a lower index of zero.

continued

POWER VISION

The First Quality Standby Power System Made To Fit Everyone's Budget

Statistics prove that every week in every area of the country there are electrical power surges, spikes, brown-outs and blackouts. Electrical power outages can destroy not only valuable data and processing time but can also cause irrevocable damage to your expensive computer hardware.



The PowerVision 300, designed for PCs, retails for a nominal \$539. Yet it matches SPS's costing twice as much feature for feature, making

PowerVision the first truly affordable high quality sine wave SPS.

In addition to the PowerVision 300 watt system, 500 and 1000 watt units are available for larger computers. All three feature an immediate transfer. PowerVision provides blackout, brownout and transient protection for your hardware and important data—ultimately saving you time and money.

C-COR Electronics, maker of PowerVision, has extensive experience in power protection devices. Our PowerVision line is backed by a one year limited warranty.

PowerVision products are as close as your phone. Don't be left unprotected any longer.

Call us toll free at 1-800-445-9366. In California call 1-619-546-9399.



PowerVision
The Power Behind The Best Minds

Listing 1: *The definition part of the SortElemType module. This module defines the new opaque data type (ElemType) and the procedure that operates on it (compare).*

```
DEFINITION MODULE SortElemType;

EXPORT QUALIFIED ElemType, compare;
TYPE ElemType; (* pointer to any data type *)

PROCEDURE compare (x, y: ElemType): BOOLEAN;
(* compare(x,y) implements: x < y
defined as NOT (y <= x), for ascending order;
and if descending order is desired
compare(x,y) should implement: x > y
defined as NOT (x <= y);
where "<=" denotes a binary relation that must satisfy
the total order properties:
1. x <= x
2. x <= y AND y <= x ==> x = y
3. x <= y AND y <= z ==> x <= z
4. x <= y OR y <= x for every x, y
*)

(* ... and other operations to manipulate the data *)

END SortElemType.
```

Listing 2: *The definition part of the Sort module. This module defines the procedure that sorts an array of items of type ElemType.*

```
DEFINITION MODULE Sort;
FROM SortElemType IMPORT ElemType, compare;
EXPORT QUALIFIED QuickSort;

PROCEDURE QuickSort (VAR A: ARRAY OF ElemType);
(* Input: an array A filled with data
Output: same array sorted.
Requires that ElemType has a total order
relation named "compare".
*)
END Sort.
```

Listing 3: *The implementation part of the Sort module. This module implements the sorting procedure defined in listing 2.*

```
IMPLEMENTATION MODULE Sort;

FROM SortElemType IMPORT ElemType, compare;

PROCEDURE QuickSort (VAR A: ARRAY OF ElemType);

PROCEDURE sort (l, r: INTEGER); (* N. Wirth, '86 *)
VAR i, j : INTEGER;
    x, w : ElemType;
BEGIN
i := l; j := r;
x := A[(l + r) DIV 2];
REPEAT
WHILE compare(A[i], x) DO INC(i) END;
WHILE compare(x, A[j]) DO DEC(j) END;
IF i <= j
THEN w := A[i]; A[i] := A[j]; A[j] := w;
INC(i); DEC(j)
```

```
END
UNTIL i > j;
IF i < j THEN sort(l, j) END;
IF i < r THEN sort(i, r) END
END sort;

BEGIN
sort(0, HIGH(A))
END QuickSort;
END Sort.
```

Listing 4: *The implementation part of the SortElemType module. This module, which is the only one that must be rewritten to handle a different kind of sort operation, gives the implementation details of the opaque data type ElemType and the compare procedure.*

```
IMPLEMENTATION MODULE SortElemType;

(* FROM FileDescriptor IMPORT FileDescr;
(used instead of definition below
when the data has already been defined)
*)

CONST EOS = 0C; (* end-of-string character *)
TYPE ElemType = POINTER TO FileDescr;
FileDescr = RECORD
name : ARRAY[0..8] OF CHAR;
ext : ARRAY[0..3] OF CHAR;
size : ARRAY[0..10] OF CHAR;
date : ARRAY[0..8] OF CHAR;
time : ARRAY[0..6] OF CHAR
END;

PROCEDURE compare (x, y: ElemType): BOOLEAN;
BEGIN
RETURN StringComp(x<.name, y<.name)
END compare;

PROCEDURE StringComp (s1, s2: ARRAY OF CHAR): BOOLEAN;
(* returns s1 < s2 *)
VAR i, max : CARDINAL;
BEGIN
i := 0; max := HIGH(s1);
WHILE (i < max) & (s1[i] = s2[i]) DO
IF s1[i] = EOS
THEN RETURN FALSE (* s1 = s2 *)
ELSE INC(i)
END;
END;
RETURN s1[i] < s2[i]
END StringComp;

END SortElemType.
```

Listing 5: *The skeleton of a program used to test the generic sort module defined by listings 1 through 4.*

```
MODULE SortTest;
FROM SortElemType IMPORT ElemType;
FROM Sort IMPORT QuickSort;
(* other imports here *)
CONST N = 100;
VAR a : ARRAY [1..N] OF ElemType;
```

```

BEGIN
  (* fill up the array with pointers to file-descriptors *)
  QuickSort(a);

  (* according to the output specification of QuickSort
  we now have the array "a" sorted. Add more code here
  to confirm that array a has been sorted correctly.
  *)

END SortTest.

```

Listing 6: Expanding the generic module to handle new situations. With redefined definition (a) and implementation (b) parts of the SortElemType module, the user of the final program can choose which of two fields to use in sorting the list of records. Note that this method still restricts the programmer to sorting a single given data type.

a

```

DEFINITION MODULE SortElemType;

  EXPORT QUALIFIED ElemType, compare, select, optionMenu;
  TYPE ElemType; (* as before *)

  PROCEDURE compare (x, y: ElemType): BOOLEAN;
  (* as before *)

  PROCEDURE select (option: CARDINAL);
  (* used by user to select desired comparison
  procedure, a default is provided until the user
  changes it *)

  PROCEDURE optionMenu;
  (* displays on the screen the available options
  *)

END SortElemType.

```

b

```

IMPLEMENTATION MODULE SortElemType;

  (* ... same type declarations *)
  VAR comp: PROCEDURE (ElemType, ElemType): BOOLEAN;

  PROCEDURE compare (x, y: ElemType): BOOLEAN;
  BEGIN (* call the procedure currently *)
    RETURN comp(x, y) (* assigned to "comp" *)
  END compare;

  PROCEDURE select (option: CARDINAL);
  BEGIN
    CASE option OF (* compare by : *)
      1: comp := compName; (* file-names *)
      | 2: comp := compExt (* extension *)
    ELSE comp := compName (* default *)
    END
  END select;

  PROCEDURE optionMenu;
  BEGIN
    WriteString("options:"); WriteLn;
    WriteString(" 1 to sort by file-name"); WriteLn;
    WriteString(" 2 to sort by extension"); WriteLn;
    WriteString(" the default is 1, any other is taken as
  1");
    WriteLn; WriteLn
  END optionMenu;

```

```

PROCEDURE compName (x, y: ElemType): BOOLEAN;
  (* ... as compare before *)

PROCEDURE compExt (x, y: ElemType): BOOLEAN;
BEGIN
  RETURN StringComp(x<.ext, y<.ext)
END compExt;

  (* more procedure implementations go here *)

BEGIN (* to initialize the module *)
  comp := compName (* default *)
END SortElemType.

```

Listing 7: An unsafe method that allows a generic routine to work with different data types. Listings (a) and (b) sketch out the structure of the definition and implementation parts, respectively, of a new generic sort module called GSort. Listing (c) shows how a comparison routine handles the conversion of a pointer (i.e., an address) to the data it points to. This method is unsafe because a programmer may accidentally use the wrong comparison operation for a given data type, and the compiler will not know that an error has been made.

a

```

DEFINITION MODULE GSort;

  FROM SYSTEM IMPORT ADDRESS;
  EXPORT QUALIFIED QuickSort;

  TYPE COMPROC = PROCEDURE (ADDRESS, ADDRESS): BOOLEAN;

  PROCEDURE QuickSort (VAR A: ARRAY OF ADDRESS; compare:
  COMPROC);

END GSort.

```

b

```

IMPLEMENTATION MODULE GSort;

  FROM SYSTEM IMPORT ADDRESS;

  PROCEDURE QuickSort (VAR A: ARRAY OF ADDRESS; compare:
  COMPROC);

  PROCEDURE sort (l, r: INTEGER); (* N. Wirth, '86 *)
  VAR w, x: ADDRESS;

  (* the rest as before *)

END GSort.

```

c

```

PROCEDURE compName (x, y: ADDRESS): BOOLEAN;
  VAR xt, yt: POINTER TO FileDescr;

  BEGIN
    xt := x; (* convert (implicitly) ADDRESS to *)
    yt := y; (* have access to the RECORD fields *)
    RETURN StringComp(xt^.name, yt^.name)
    (* xt^.name gets the name field of the record
    pointed to by xt
    *)
  END compName;

```

Pointers are handy to use, since the algorithm can move them easily.

After compiling listing 4, you are ready to use the `Sort` and `SortElemType` modules, which are now configured to sort a list of filenames alphabetically. Listing 5 shows the skeleton of a program that uses these modules to perform this sort. You should keep this program as a test of your sort library.

A More Versatile Implementation

At this point you may ask, "What happens if I want to sort both by name and by extension? I can't have two different `SortElemType` implementations in the same program."

Since you want to do several compare operations on the same data type, you can solve this problem by changing the `SortElemType`. You must change the implementation of `compare` so that it returns the proper value based on your choice of sort type (see listings 6a and 6b). You can do this in Modula-2 by declaring a variable of a procedure type; that is, a variable whose value is a Modula-2 procedure.

In listing 6b, the variable `comp` represents any element of the class of functions that have two parameters of type `ElemType` and a return value of type `BOOLEAN`. You can assign any such procedure to the variable `comp` with the statement `comp := procname`.

This is, in fact, what the `select` procedure does; it lets you choose between the available procedures (shown, if necessary, by the `optionMenu` procedure). Notice that since `comp` is not exported in the definition part of this module (see listing 6a), it can only change value inside this implementation module and is safe from tampering by any other module. Another point is that you must initialize `comp` to some value, and you do this in the initialization part of the module (the last three lines of listing 6b).

In this example, we generalized a module to allow a program to sort its records on different fields. By introducing other procedure-type variables, you could provide other kinds of control, such as selecting one of several sorts to use, changing the order of sorting, or other such modifications.

This change in the `SortElemType` module does not affect the `Sort` module, and its access to the type and comparison

procedure are the same as before. But you still have to recompile `Sort` because it imports a module whose definition part has been redefined (`SortElemType`).

Some people may criticize the use of the exported function `compare` as inefficient; after all, it does nothing but call `comp`, and you could save time by exporting `comp` and using it instead of `compare`. The reason for this particular way of coding is safety: By encapsulating `comp`, you can change it only inside this module. Exporting it, however, makes the program somewhat unsafe because you could conceivably change it from the outside.

The point here is that you have traded efficiency for safety, which Liskov and Guttag (see reference 4) say is sometimes necessary. When a module is intended to be used by anyone, they say, then you should opt for safety; if only you use it, then you can take chances and try to gain some efficiency. (We found the improvement to be less than 1 percent in running time, measured using sample runs with 100 file descriptors.)

Unsafe Generic Modules

The reusable packages that are built following the method just shown have a disadvantage that will surface if somebody wants to sort different data types in the same program—it can't be done. This shortcoming arises from the fact that the implementation of the formal parameter module (the implementation part of `SortElemType`) is, at the same time, the actual parameter instantiation (the module in which `ElemType` is defined). Since there can be only one implementation of any module in a program, you are limited to one instantiation, or definition, of `ElemType`.

You can get around these restrictions by using the low-level facilities of Modula-2. In doing so, however, you will lose some of the protection against error that Modula-2 normally provides. Listings 7a and 7b show how to build a generic sort without using a formal parameter module like `SortElemType`.

In listings 7a and 7b, the array of pointers has been replaced by an array of type `ADDRESS`, the elements of which are compatible with any pointer type. Pointers are convenient to use, since the algorithm can move them easily.

The alternative of using actual data, probably structured, results in an expensive operation: You must move the data word by word. Notice that, in listing 7a, `QuickSort` now sorts an array of addresses instead of `ElemTypes`. Also, `compare` is now a procedure variable of type `COMPROC` (which is any procedure that takes two addresses for arguments and returns

a Boolean value).

When you use this method, you must declare that all the arrays you will sort are arrays of elements of type `ADDRESS`. The specific comparison routine for a given array must then use implicit- or explicit-type transfer to access the actual data (which is pointed to by the array elements of type `ADDRESS`) and return the correct value. Listing 7c shows how you would rewrite `compName` to work within this scheme.

This generic module allows you to use any number of data types and their respective comparison procedures in the same program. The reason we call this implementation unsafe springs from the definition of `compare`, which is any procedure that receives two addresses and returns a Boolean value. If you mistakenly send an array with one type of data and a function that compares another kind of data, the compiler will not catch your error and the program may give wrong answers or even cause the system to crash. Nevertheless, if your program needs to sort more than one data type, this is an approach you can use—but carefully!

Benefits of Reusable Software

The methodology described in this article is only one of a number of ways to obtain reusable modules; see references 5 and 6 for other approaches. With these and other such methods, you gain two important things: productivity, by reducing the effort you spend programming, debugging, and testing those modules already coded as generic; and reliability, by building new software on existing modules that you know work properly.

These benefits make the work expended in designing the module this way well worth it. ■

REFERENCES

1. Goguen, J. "Parameterized Programming." *IEEE Transactions on Software Engineering*, Volume SE-10, No. 5, September 1984, pp. 528-543.
2. Wirth, N. *Programming in Modula-2* (3rd edition). Berlin, West Germany: Springer-Verlag, 1985.
3. Wirth, N. *Algorithms & Data Structures*. Englewood Cliffs, NJ: Prentice Hall, 1986.
4. Liskov, B. and J. Guttag. *Abstraction and Specification in Program Development*. Cambridge, MA: The MIT Press/McGraw-Hill, 1986.
5. Special issue on Software Reusability. *IEEE Transactions on Software Engineering*, Volume SE-10, No. 5, September 1984.
6. Shamma, N. "Creating Reusable Modules." *BYTE*, January 1986, pp. 145-150.



There's One
Personal
Computer
Company
That Always
Has The
Right
Solutions

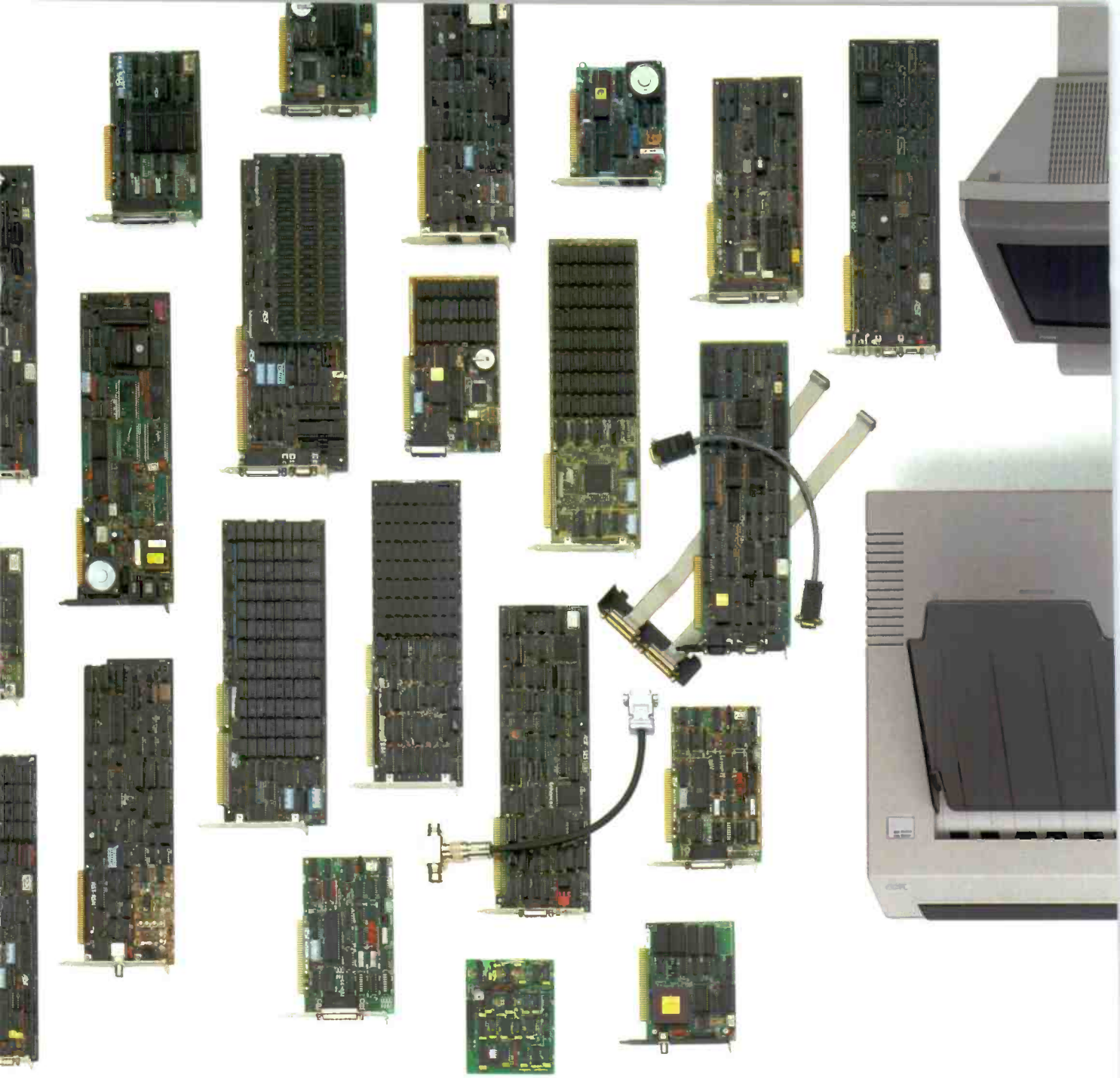

Board-level best. Do you recognize these boards? Look under the hood of your IBM® PC, XT or AT.® With sales of SixPakPlus®, Rampage® and Advantage™ multi-function boards exceeding 2 million, you can bet most IBM Personal Computers are enhanced by AST.

Think of us every

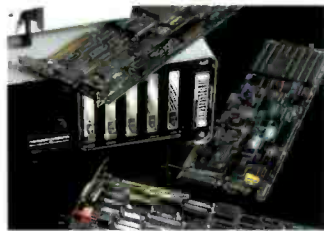

Hundreds of solutions to enhance your IBM PC.

time you need more memory, more I/O, graphics or modems for your PCs, XTs, ATs, and yes, especially the new IBM Personal System/2™ AST enhancements

contribute to a more productive overall office environment.

First in a series of system solutions. Waste no

time trying to match components to create a complete system. You can purchase, plug in and operate AST's integrated workstation solutions in no time.

All of our products meet our strict guidelines for industry compatibility, but advanced architecture and innovative technology transform AST computing solutions into something more.

You get more performance

Memory
Multifunction
Data
Communications
Graphics
Laser Printers
LANs
Personal
Computers
Total Solutions

With so many different standards and daily advancements in the personal computer industry, it becomes a superhuman responsibility to stay informed. And yet, you must, in order to select the best products for your company and your own personal computer.

What's the solution? Rely on one company – AST Research. With a solid track record for quality and performance among a full-range of computer solutions for the IBM PC, XT, AT and Personal System/2, AST has earned a name that assures satisfaction.



You Guessed It!

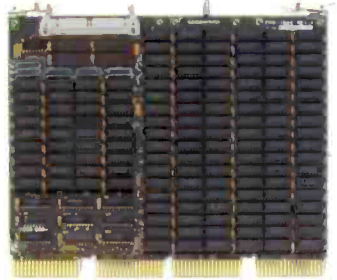
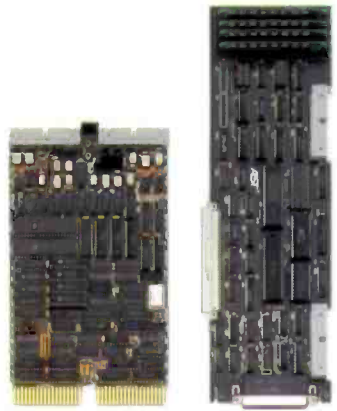
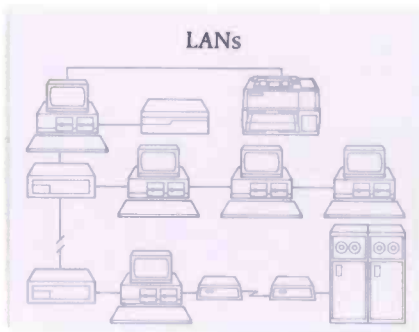
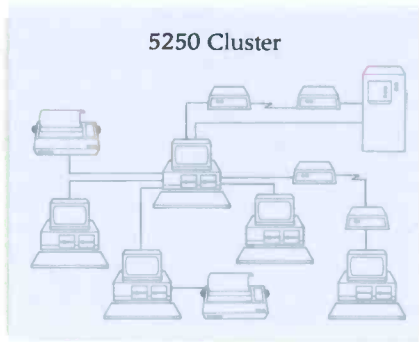
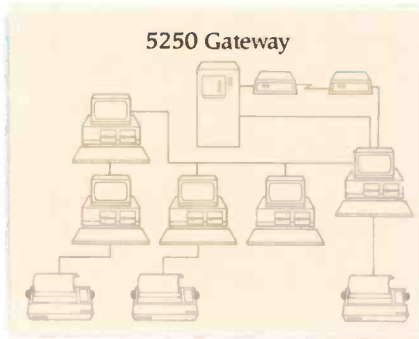
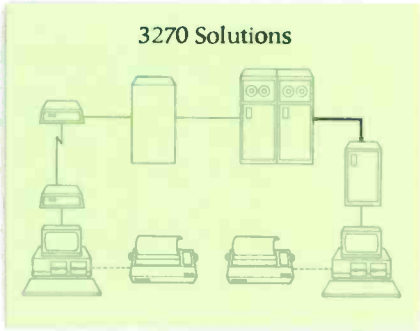
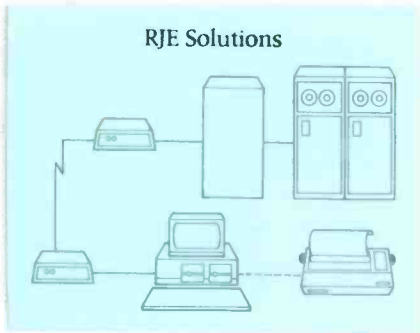

the expertise to AST.

Our terminal emulation products lead the industry in providing unique, cost-saving ways for your PCs to be linked with minicomputers or mainframes. And our simple-to-install networks with advanced operating system features appeal



Connectivity for IBM, Apple and DEC computers.

to both first-time and sophisticated users.

Bridging the computer gap with DEC™ and Apple® enhancements. AST crosses

industry boundaries to bring Apple and Digital Equipment Corporation (DEC) users the same experience and com-

mitment to quality we give to the IBM world.

In addition to manufacturing industry-specific enhancements, AST offers products that bridge normally incompatible technologies—like MS-DOS coprocessor boards that allow Macintosh users to run IBM applications software and terminal emulation packages allowing IBM PCs to communicate with DEC computers.

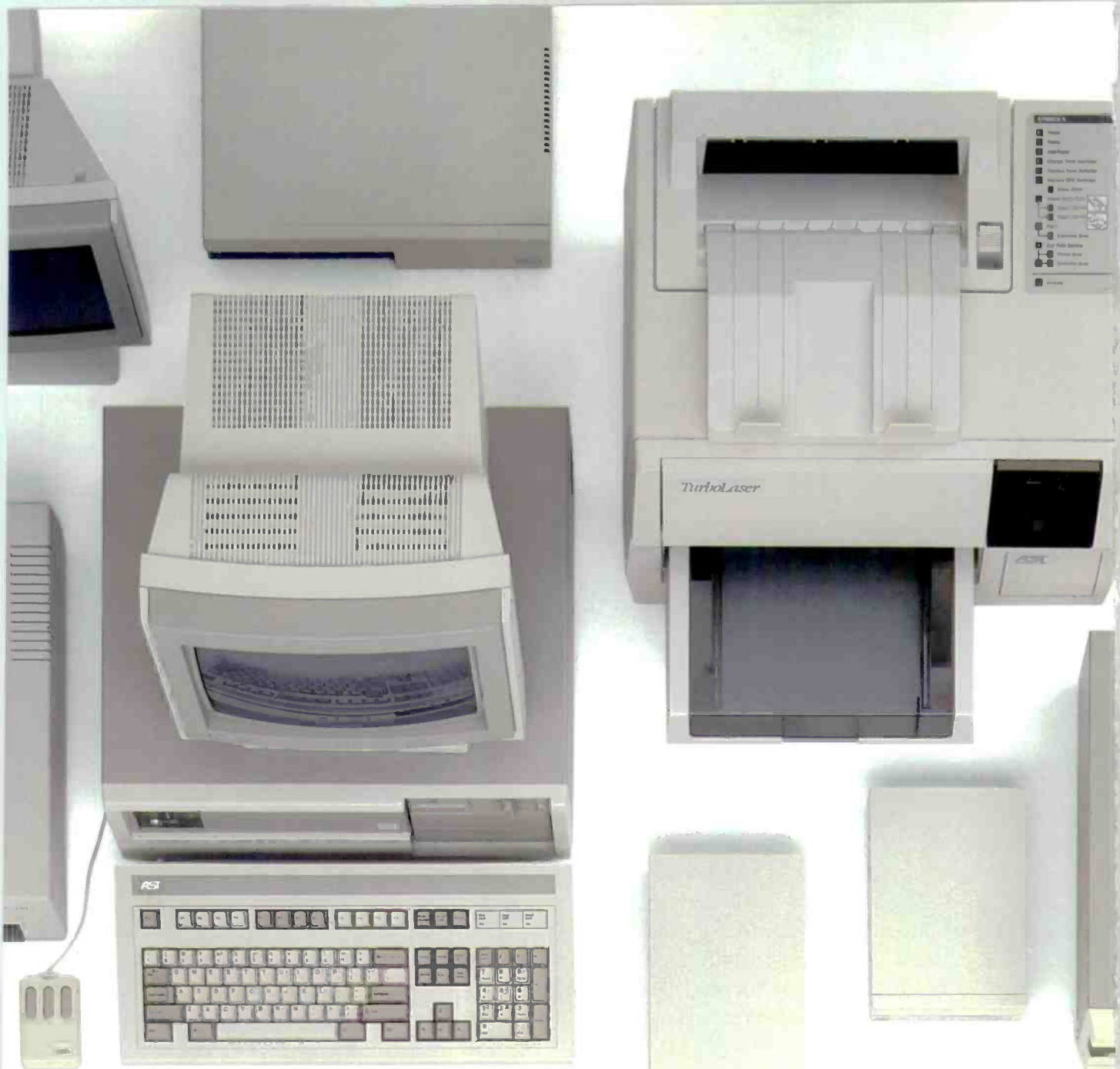

from the AST Premium/286™ AT-compatible personal computer, with its 10 MHz processing speed and true, zero wait-state operation. You get more extensive printer and plotter emulations and faster, high-quality output from the AST TurboLaser™. And more software and complete system compatibility from the



Complete system solutions based on the AST-Premium/286.

Compatible connectivity.

Buy communications solutions today that you can continue to expand and use tomorrow. AST's complete line of micro-to-mini, micro-to-mainframe, gateway and local area networking solu-

first desktop publishing solution for the IBM world, the AST Premium Publisher™

tions provide total compatibility with industry standards. Plus, a common, user-friendly interface throughout AST's communications products allows you to mix and match AST products in order to create a custom solution. So, if SNA, BISYNC, 5251, 3270, LU6.2PU2.1, Gateways, NetWare™, Token Ring Network, IEEE 802.3 and other communications specifications worry you, leave



Showing up in first place, worldwide. It's no accident that AST products continue to win over the hearts and minds of editors and customers alike. AST's track record for quality is hard-earned.

It begins with 1,150 employees throughout the world singularly committed to product excellence. It continues with state-of-the-art research and development, manufacturing and worldwide corporate facilities encompassing a quarter of a million square feet. And it's carried on by a wide network of dealers, OEM partnerships, distributors, training personnel and service centers always at your service.

Whether your business requires a single board, or complete system, you'll find AST Research is the single solution for powerful computing. Call us today at (714) 756-4700. Or fill out the coupon below and mail it to AST Research, Inc., 2121 Alton Ave., Irvine, CA 92714-4992.

Please send me information on the following:

- IBM:
 - Multifunction
 - PC to Mainframe/Minicomputer Communications
 - Graphics
- Local Area Networks
- AST Premium/286 Personal Computer
- AST Premium Publisher
- AST TurboLaser
- Apple enhancement products
- DEC enhancement products

Name _____

Title _____

Company _____

Address _____

City/State/Zip _____

Phone _____

To help us better serve you, please list the magazine and issue date in which this ad appeared. _____

Michael J. Sorens

Teaching Old Screens New Tricks

Create fancy screen displays for your homegrown programs

Have you ever wondered how the big software packages make those flashy screen displays?

You could always purchase a screen-management program, but for those who enjoy doing it themselves, I will provide some insight and a few easy techniques for creating fancy displays on your IBM PC.

You can manipulate bold (or bright), underlined, reverse, or blinking characters on your monochrome monitor. (The techniques can easily be adapted to work with a color monitor.) I will not address the use of graphics boards or adapters, and I have limited my graphics discussion to the standard graphic character set, ASCII codes 128 through 255, which is sufficient for making borders, windows, and other shapes on the screen.

Screen Writing

There are two approaches to creating displays: screen writing and memory writing. Screen writing involves writing sequences of characters, including special control characters, to the screen. The control characters manipulate the screen.

Chapter 2 of the DOS 2.10 technical manual describes "extended screen and keyboard control." For example, consider designing your DOS prompt so that it shows the current path, followed by a > and a space, but having it displayed in bright letters. Here's the prompt command that you'd need:

```
prompt $e[1m$P$G$e[0m $a
```

Let's dissect this command piece by piece. The dollar sign (\$) characters are documented under the prompt command. The \$e is an escape character (ASCII 27), \$p is the current path, \$g is the > symbol, and \$a is undefined, but it is

used to force a space after the >. To print bright characters on the screen, it is necessary to write an escape character followed by [1m. To restore dim characters, you use an escape character followed by [0m. Put the pieces together as shown, and you get the effect described above, except for one thing: You must include a device driver, called ANSI.SYS, in your CONFIG.SYS file.

If you do not have a CONFIG.SYS file, create a text file with that name and keep it in your root directory. For our purposes, all it needs is this single line: DEVICE = ANSI.SYS. This causes the screen to have some smarts; rather than printing some textual representation of an escape character (my machine prints an arrow), it executes the escape character as a screen-control function.

After you add this line to the CONFIG.SYS file, reboot your computer so that the device driver will take effect. Then the DOS prompt appears as described above.

To create bright letters inside a program, the technique is essentially the same. I'll use Turbo Pascal for the programming examples, but the names should be suggestive enough for you to readily adapt the code to your favorite language.

The code shown in listing 1 first defines three constants. Then, the writeln statement displays the list of things inside the parentheses in the order shown. This will cause string 1 to appear in bright text, while string 2 will appear in dim text (see code fragment A). Other characteristics, such as blinking, reverse, colored, and underlined text, can also be printed in this way once we know the appropriate codes. Note, however, that once an escape sequence is printed, all subsequent output will appear in the specified style until a new escape sequence changes it.

Note one additional prerequisite when using a programming language: You must direct the output specifically to the standard output device—not to the screen. This may seem perplexing because, by default, the standard output device is the screen. But the screen is not always the standard output device. In Turbo Pascal 3.0, for example, writeln will not work unless you first use the {\$Pn} compiler directive (where n is some integer larger than zero) to indicate that all writeln should go to the standard output device.

Now let's examine a framework for easily changing from one style of text to another, rather than laboriously using the escape codes. I've used Turbo Pascal for the examples. First, let's establish the definitions as shown in code fragment B. Pascal lets you create new types. The first declaration enables you to create variables of type ScreenStyle, which can have only one of the five values shown. The second declaration allows you to create variables of type ShortString, which are just strings whose maximum length is 25 characters. I will now introduce two routines, SetOneStyle and SetTextStyle, which return strings of control sequences, such as an escape character followed by [1m.

SetOneStyle returns a string that forces a single text style, while SetTextStyle returns a string that can be a combination of one or more styles, such as underlined and boldfaced characters. To

continued

Michael J. Sorens, a senior software engineer, holds B.S. and M.S. degrees in computer engineering and science from Case Western Reserve University. He can be contacted at LASA Industries, 505 Lincoln Ave., San Jose, CA 95126, (408) 995-5272.

create a string that initiates blinking characters, for example, you call `SetOneStyle(BlinkText)`. This returns a text string with embedded control characters. In other words, you can assign the returned value to a variable; let's call it `BlinkString`.

```
BlinkString :=
  SetOneStyle(BlinkText);
```

We can then display `BlinkString` just as we displayed control codes above:

```
write(BlinkString);
```

or, if there is no reason to store the result of `SetOneStyle` in `BlinkString`, we can print the function result directly:

```
write(SetOneStyle(BlinkText));
```

Both `write` statements achieve identical results. (The difference between `write` and `writeln`, by the way, is that the latter will terminate a line and start a new line.)

You can use the routine `SetTextStyle` to create combinations of styles. The generalized control-string format is an escape character followed by `[#;...;#m`, where you can use more than one code between the `[` and the `m`. Each `#` character represents a style code. The `...` indicates that you can repeat these style codes. You must separate each pair of codes by a semicolon, and an `m` must terminate the sequence. `SetTextStyle` requires two input parameters: a desired style code and an existing style string. The new style code is added to the existing style string so that it maintains the above format (see code fragment C).

You set the local variable `CodeChar` depending on the value of the style parameter with the case statement. Then you assign a value to the function. If the `ExistingString` is empty, you just create a standard escape string, such as `[5m`. Otherwise, you need to chop off the `m`, add the `;` separator, add the new code, and then tack on the `m` at the end.

In `SetOneStyle` (see code fragment D), you first create a string to set the screen back to normal, regardless of its previous condition. If you are actually requesting something other than "normal," then you concatenate the second code by a second call to `SetTextStyle` as shown in code fragment D.

You can intermix the different text styles freely, for the most part, so you must take some care in creating escape sequences. If you write an escape sequence for blinking text, as shown above, and then later write an escape sequence for reverse text, you will actually get reversed blinking text, because you have

not turned off the blinking effect. It is best to use some type of flag to keep track of the current styles. To change a style, then, the necessary steps are to modify the flags to get the condition you want, send an escape sequence to turn off all effects, and send an escape sequence to es-

tablish all effects specified by the flags.

Code fragment E is a routine for managing a set of Boolean flags so that you can examine the current style of your screen by checking the set of corresponding flags. The flags are Boolean variables called `Bold`, `Blink`, `Underscore`, and `Re-`

Listing 1: Code fragments used to generate screen attributes.

Code fragment A

```
const
  BrightControl = "[1m";
  DimControl = "O[m";
  ESC = #27; ...
writeln(ESC, BrightControl, string1,
  ESC, DimControl, string2);
```

Code fragment B

```
type
  ScreenStyle = (BoldText, BlinkText, UnderscoreText,
  ReverseText, NormalText);
  ShortString = string[25];
```

Code fragment C

```
function SetTextStyle(
  Style: ScreenStyle; {the desired text style}
  ExistingStyle: ShortString {the control string to modify}
): ShortString;
var CodeChar: char;
  TextStyle: ShortString; begin
  case style of
    BoldText: CodeChar := "1"; {the magic numbers}
    BlinkText: CodeChar := "5";
    UnderscoreText: CodeChar := "4";
    ReverseText: CodeChar := "7";
    NormalText: CodeChar := "0";
    else writeln("Internal error in SetTextStyle");
  end { case };
  if (ExistingStyle = "") then
    TextStyle := chr(27) + '[' + CodeChar + 'm'
  else SetTextStyle :=
    copy(ExistingStyle, 1, length(ExistingStyle)-1) + ';' +
    CodeChar + 'm';
  end;
```

Code fragment D

```
function SetOneStyle(Style: ScreenStyle): ShortString;
var CodeStr: ShortString; begin
  CodeStr := SetTextStyle(NormalText, "");
  if (style = NormalText) then SetOneStyle := CodeStr
  else SetOneStyle := SetTextStyle(style, CodeStr);
end;
```

Code fragment E

```
function RefreshStyles: ShortString;
var CodeStr: ShortString;
begin
  CodeStr := SetTextStyle(NormalText, "");
  if bold then CodeStr := SetTextStyle(BoldText, CodeStr);
  if blink then CodeStr := SetTextStyle(BlinkText, CodeStr);
  if under then CodeStr := SetTextStyle(UnderscoreText, CodeStr);
  if reverse then CodeStr := SetTextStyle(ReverseText, CodeStr);
  RefreshStyles := CodeStr;
end;
```

Code fragment F

```
write(SetOneStyle(Reverse));
DrawBorders;
{user defined routine}
write(RefreshStyles);
```

verse, which keep track of the four named styles. Suppose you want to create a border in reverse characters while not interfering with the rest of the display. You need to write a control string to turn on the reverse-character style before you start drawing the border, and then you

must write a control string to restore the screen state so that the subsequent text will be displayed in the same style combination as it was before you turned on the reverse characters.

RefreshStyles (see code fragment E) will first turn all styles off and then reac-

tivate any that are supposed to be on. Thus, in order to draw your reverse border, you first set the screen to reverse style, draw the borders, and then refresh the styles. It's fine to change the style without adjusting the flags in this instance, since you will be refreshing the state to agree with the flags before you do anything else. The code might look like that shown in code fragment F.

For drawing a window, characters in the ASCII range 176 through 223 are appropriate. They provide an appealing screen display for many applications. The techniques described so far can create specific strings of text with a lot of flexibility. For entire screen design, however, memory writing is more appropriate.

Code fragment G

```
type ScreenChar =
  record
    Value: char; {actual character}
    Style: byte; {text style}
  end;
```

Code fragment H

```
const Count= 10;
var Asterisks: array [1..Count] of ScreenChar;
procedure CreateAsterisks;
begin
  for i := 1 to Count do begin
    asterisks[i].value := '*';
    asterisks[i].style := $87; {hexadecimal notation}
  end;
  move(asterisks, destination, Count * 2);
end;
```

Code fragment I

```
const Count= 10;
      TwiceCount= 20;
var Asterisks: array [1..TwiceCount] of byte;
procedure CreateAsterisks;
begin
  for i := 1 to Count do begin
    asterisks[(2*i)-1] := ord('*');
    asterisks[(2*i)] := $87;
  end;
  move(asterisks, destination, TwiceCount);
end;
```

Code fragment J

```
const ScreenSize= 2000;
ScreenBytes = 4000; {twice ScreenSize} LineSize= 80;
type ScreenImage = array [1..TotalLines, 1..LineSize] of ScreenChar;
      BlockImage= array [1..ScreenBytes] of ScreenChar;
var Lines: ScreenImage absolute $B000:0;
      Screen: BlockImage absolute $B000:0;
```

Code fragment K

```
procedure CreateAsterisks;
begin
  for i := 1 to Count do begin
    Screen[origin + i].style := $87;
    Screen[origin + i].value := '*';
  end;
end;
```

Code fragment L

```
procedure ShowHelp;
var ScreenCopy: BlockImage;
begin
  fillchar(ScreenCopy, ScreenBytes, ' '); {blank out array}
  for i := 1 to HelpSize do
    for j := 1 to length(HelpLines[i]) do begin
      ScreenCopy[i,j].value := HelpLines[i,j];
      ScreenCopy[i,j].style := HelpStyles[i];
    end;
  move(ScreenCopy, Screen, ScreenBytes); end;
```

Code fragment M

```
var MonoScreen: ScreenImage absolute $B000:0;
    ColorScreen: ScreenImage absolute $B800:0;
    Monitor: ScreenImage;
```

Code fragment N

```
if (VideoCode = 7) then Monitor := addr(MonoScreen)
else Monitor := addr(ColorScreen);
```

Memory Writing

The memory-writing method is somewhat more low-level, but you can create very fast screen displays with it, and you do not need the ANSI.SYS driver in your CONFIG.SYS file. I'll limit my discussion to the IBM PC monochrome monitor, as in the previous section; you can implement colors by simply adding more flags and more style choices.

The IBM PC display screen is memory-mapped at address B000:0000 for monochrome displays (segment B000, offset 0) and at B800:0000 (segment B800, offset 0) for color displays. Writing data into memory at the address of the screen will show that data on the display. Since there are 25 lines of 80 characters each, the screen occupies exactly 4000 bytes of contiguous memory. Each screen character is represented as a 2-byte entity. You will need a record structure that can easily access memory locations, like that in code fragment G.

This creates a new data type consisting of a character called Value followed by a byte called Style. Bytes and characters are actually the same thing, but you can refer to them differently. If you define a variable Spot of type ScreenChar, then you can refer to the two components of Spot as Spot.Value and Spot.Style. For a single character, the two bytes of ScreenChar represent the character and the text style, in that order. If you have a tool that lets you examine memory, take a look. The hexadecimal codes for the different styles are shown in table 1.

This means that you can modify your screen manually if your favorite language has a fast, efficient procedure for moving blocks of memory around. Turbo Pascal, for instance, has the move procedure: move(source, destination, count), wherein you move the specified number of bytes (count) from the source to the destination. As an example, let's

continued

Table 1: Hexadecimal codes for text functions.

Normal (low intensity)	07
Bold (high intensity)	0F
Underline	01
Blink	87
Reverse	70

Table 2: Bit settings within the style codes. An X indicates a "don't care" condition.

Bold	XXXX	1XX1
Underline	X000	X001
Blink	1XXX	XXXX
Reverse	X111	X000

create a field of 10 blinking asterisks. Two equivalent versions are shown in code fragments H and I. The version shown in code fragment H uses Pascal record structures and is more readable. Note that you use the destination variable without yet defining it. If your language of choice does not have records but has arrays, you can achieve the same effect, but the calculations look a little more complicated, as shown in code fragment I.

Using either definition, you first create a string of asterisks interleaved with a string of style codes. Then you move the coded asterisk string to your destination. But where is the destination? Recall that the display screen consists of 2000 character records located at a specific address. Thus, you need to be able to talk

about absolute memory locations. Turbo Pascal allows you to declare variables absolutely, as shown in code fragment J.

Here you have created two different representations for the screen, both representing the same memory locations. `Lines` is set up as a two-dimensional array of lines and columns, while `Screen` is just a single array of screen characters. Both variables are located at the same specified address, exactly overlaying the location of screen memory. You can use some offset into the `Screen` array as your destination in `CreateAsterisks`. Actually, you can eliminate the move by using the `Screen` array directly (see code fragment K).

The new routine allows you to write directly to the screen as if it were memory.

You need to set the variable `origin` to some appropriate value between 1 and (2000 count). The representations above allow you to access the screen memory as either individual bytes or as whole lines. Thus, rather than accessing something in the *i*th position of line *n* by saying `Screen[(n * LineSize) + i]`, you can just use `Lines[n, i]`.

For incredibly fast displays, you can build up a copy of the screen somewhere in memory, setting whatever text-style attributes you like, and then executing a block move to transfer the data to the screen instantly.

Suppose, for example, that you have an array of strings that you want to print, perhaps a help screen. Let's call this array `HelpLines` and fill a copy of the screen, called `ScreenCopy`, with these strings, and then move the copy to the display for an instant picture update. Also, let's use a second array, `HelpStyles`, which contains style codes for each corresponding string in `HelpLines` (see code fragment L).

This procedure allows us to mix reverse lines, bold lines, and so on, on the same screen. How about combining effects, such as blinking and reverse text? For this you need more "magic num-

Big Blue introduced a new standard.

By now you've heard that Big Blue has introduced a new PC standard. Naturally, Amdek® is right on top of this technology.

Introducing our latest technical achievements—the Amdek 732 color and 432 monochrome monitors.

Sharper, cleaner text. Richer, more vibrant color. Vertical refresh as high as 70 Hz. to eliminate flicker and maintain a crisp, steady image. An anti-glare screen that reduces eye fatigue. And a tilt/swivel stand that prevents neck strain.

The 732 allows you to choose from a palette of over 256,000 colors. And the text switch delivers clear single color text for word processing.

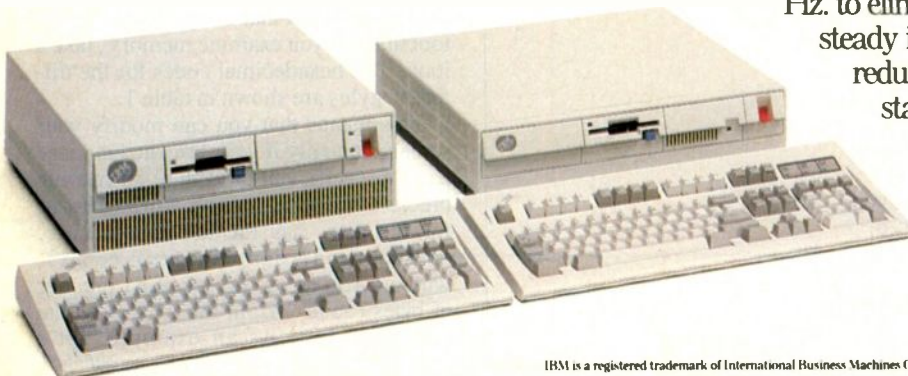

IBM is a registered trademark of International Business Machines Corp. Personal System/2 is a trademark of International Business Machines Corp.

bers." Table 2 shows how the different codes can and cannot be combined. The representations show the bit settings within the style byte. To achieve a certain style, set the ones and zeros shown. The X terms can be either zeros or ones.

Those familiar with digital logic will recognize the X terms as "don't care" terms. Hence, to create a bold character, you can use the code 0F, 5F, FF, or 09. However, be careful; 09 also fits the pattern for underlining, so both styles will appear. Table 1 shows, for example, that you cannot mix reverse characters with underlined ones, since the low-order bit of the reverse style is a 1, while that of underlined style is a 0.

Table 3 shows the useful combinations in both hexadecimal and binary. These are like a set of mnemonic constants for use in a program. Finally, let's see how to make a program flexible enough for it to recognize and act upon the difference between a monochrome monitor and a color monitor. Buried obscurely in some portion of memory is a single integer that can tell you what type of monitor you have. So you define an absolute variable:

```
var VideoCode: integer absolute
$0040:$0049;
```

Table 3: Some useful combinations of attribute codes, shown in binary and hexadecimal.

Normal	0000 0111	07
Bold	0000 1111	0F
Underline	0000 0001	01
Blink	1000 0111	87
Reverse	0111 0000	70
Bold and underline	0000 1001	09
Bold and blink	1000 1111	8F
Underline and blink	1000 0001	81
Blink and reverse	1111 0000	F0
Bold, underline, and blink	1000 1001	89

If this value is a 2 or a 3, the display is color; if it's a 7, the display is monochrome. Other values may or may not have any significance.

Now you can tell what type of display you have. How do you use this information? Modify the previous definition of Screen, renaming it MonoScreen, and add two more definitions (see code fragment M).

Somewhere in your program initialization, you need to set up the Monitor variable for use by the rest of the program, as shown in code fragment N.

The addr function returns the address

of the specified variable. From that point on you no longer need to worry about what type of display screen you have. All references to it, however, must be through the pointer variable, Monitor. Thus, instead of using Screen[n], you use Screen^[n] in the code.

Custom-Made

Today's sophisticated programs need to incorporate impressive screen displays without sacrificing speed. With a few tools, you can enhance your programs with the look and feel of expensive custom-made software. ■

We can top that!

For the ultimate in monochrome, the 432 features a large 14-inch, flat-surface screen that actually displays larger type for easier viewing.

And because the Amdek 732 and 432 are compatible with IBM's new Personal System/2™ Video Graphics Array (VGA) and MultiColor Graphics Array (MCGA), the image of all your programs will look better than you've ever imagined.

At Amdek, we weren't content with just meeting the new standard.

Our goal was to exceed it!

AMDEK

Clearly the finest in monitors.

1901 Zanker Road, San Jose, CA 95112 Phone: 800/PC-AMDEK FAX: 408/436-8187



The standard
by which all other monitors
are monitored.



MultiSync

*So perfect a solution for
business graphics it's become
the best-selling color monitor.*

Like most revolutionary products, the NEC MultiSync is based on a simple idea: Instead of one monitor for one board, why not have a single monitor compatible with all graphics boards. From CGA to PGC and beyond.

That simple idea has made MultiSync the world's best-selling color monitor and the undisputed industry standard.

MultiSync offers a maximum resolution of 800 x 560 for brilliant business graphics. And compatibility with old and new systems from PC/XT/AT to IBM PS/2 and Apple Mac II. It has a 14" diagonal screen, tilt/swivel base and 7-way text switch that lets you choose the color that's easiest on your eyes.

Best of all, it has one feature no one else can give you at any price: NEC. So why settle for monitors trying to equal the standard when you can have the one that created it. For literature or a

IBM PC XT and AT are registered trademarks of the International Business Machines Corporation

dealer call 1-800-447-4700. For technical details call NEC Home

Apple and Mac II are registered trademarks of Apple Computer, Inc.

Electronics (USA) Inc. 1-800-NEC-SOFT.

NEC is a registered trademark of NEC Corporation



QNX vs UNIX

Architecture can make or break a computer system.

If the sheer weight of UNIX brings the PC to its knees, all applications running under it will suffer. Conceived more than a decade and a half ago, UNIX is today the result of modifications, additions and patches by hundreds of programmers. It needs the resources of at least an AT.

Compare this to the QNX O/S, designed by a dedicated team with a common purpose and complete understanding of both the software and the environment in which it must run. Having elegantly solved the problem of inter-task communications, QNX is more than capable of both networking and real time performance — the superior choice for process control and office automation systems.

Quick and efficient on a PC, QNX soars on an AT. QNX occupies 80K (stand-

alone version) to 114K (network version) of system memory and allows 40 tasks (programs) and up to 16 terminals per computer.

QNX modular architecture facilitates easy adaptation and extensions by software developers for specific requirements. In addition, PC-DOS runs as a single-tasking guest operating system under QNX. With the DOS Development System, DOS EXE files can be developed in shorter time than under DOS itself.

Communication among all tasks is via "message-passing." Tasks anywhere on a network of up to 255 computers communicate rapidly and transparently with each other.

With the true distributed processing and resource sharing of QNX, all the

resources on the network are available to any user. Application programs and data can be distributed over the network without having to go through a central file server.

Network growth is fast and simple. If your disk becomes a bottleneck, add a disk anywhere on the network. If your needs outgrow your present configuration, just add terminals and/or computers as required, without having to re-write programs and without system degradation.

If you would like to know the secret of the QNX architecture, please give us a call. We invite End Users, VAR's, OEM's and Software Developers to discover a whole new world of computing capabilities.

Over 30,000 systems have been installed worldwide since 1982.

THE ONLY MULTI-USER, MULTI-TASKING, NETWORKING, REAL-TIME OPERATING SYSTEM FOR THE IBM PC, AT, THE HP VECTRA, AND COMPATIBLES.

Multi-User	10 (16) serial terminals per PC (AT).	C Compiler	Standard Kernighan and Ritchie.
Multi-Tasking	40 (64) tasks per PC (AT).	Flexibility	Single PC, networked PC's, single PC with terminals, networked PC's with terminals. No central servers. Full sharing of disks, devices and CPU's.
Networking	2.5 Megabit token ring. 255 PC's and/or AT's per network. 10,000 tasks per network. Thousands of users per network.	PC-DOS	PC-DOS runs as a QNX task.
Real Time	2,800 task switches/sec (AT).	Cost	From US \$450. Runtime pricing available.
Message Passing	Fast intertask communication between tasks on any machine.		

For further information or a free demonstration diskette, please telephone (613) 591-0931.

Quantum Software Systems Ltd. • Kanata South Business Park • 175 Terrence Matthews Crescent • Kanata, Ontario, Canada • K2M 1W8

UNIX is a registered trademark of AT & T Bell Labs. IBM PC, AT, XT and PC DOS are trademarks of IBM Corp. HP and Vectra are registered trademarks of Hewlett-Packard Company.

Inquiry 335

Constructing an Associative Memory

This simple nonlinear neural network runs on your PC

From the earliest days of behaviorist psychology, scientists have believed that the associative structure of learning resides in the neural microstructure of organisms. But where do memorized patterns reside? Do we encode *Gone With the Wind* in a cell or do we somehow superimpose it on or between several cells? How is the ability to fix a flat tire or to play the *Moonlight Sonata* stored in memory? How do we learn the color green from green things, or triangularity from triangles? How do asynchronous neurons keep any pattern, such as a phone number, reverberating in short-term memory long enough for us to learn it?

An associative memory is a mapping from data to data, a mathematical abstraction from the familiar associative structure of human and animal learning. We associate behavioral responses with sensory stimuli, effect with cause, like character with like faces, breakfast with sizzling bacon. An associative memory is parallel distributed—as in a neural network, for example—when it memorizes data by superimposing it on the same memory medium.

I will show you how to construct the simplest nonlinear neural-network associative memory—called a BAM (bidirectional associative memory)—that recalls or content-addresses stored associations (x, y) by minimizing a system “energy” (which I will define mathematically later). The BAM is a two-layer feedback network of interconnected neurons. Each neuron a_i in layer or field F_A is totally connected by “synapses” to every neuron b_j in field F_B , and vice versa, and no neurons are connected within a field. Associations (x, y) are stored by placing them at local energy minima. Input patterns tend to map into the most similar stored asso-

ciation as the input “rolls” into the nearest energy minimum.

In a BAM, and in most neural networks, patterns are stored in the edges, or synapses, between the neurons. The stable reverberation of patterns across fields of neurons—produced by a BAM energy minimum or other network mechanism—constitutes short-term memory. STM reverberations gradually seep pattern information into long-term memory (LTM), the synapses between the neurons.

Modern computers store everything in single “cells.” Brains almost certainly do not. Computers learn by rote, not by example. Computers excel at high-speed serial computation but fail at real-time pattern recognition. Brains do the opposite. Computers implement precise algorithms through the synchronous operation of their cells. Brain cells operate asynchronously as a nonalgorithmic dynamic system, which presumably can be approximated with a system of nonlinear difference or differential equations. In short, a computer is a breed of adding machine. A brain is more akin to a market economy, a galactic system, or a swarm of atomic particles.

Now we have hardware devices, called neurocomputers, that behave like brains but look like computers or coprocessors. Neurocomputers are electrical or optical implementations of neural networks. Neural networks are programmable dynamic systems. Neurocomputers are the engineering by-product of the science of artificial neural systems (ANS), which seeks to explain mind and brain as programmable dynamic systems and rests on the mathematical information-processing principles of neural-network models. Associative memories are fundamental computing structures of ANS and can be naturally implemented on neurocomputers. You can simulate small-scale as-

sociative memories, such as BAMs with few neurons, on digital computers with little effort.

The Benefits

Associative neurocomputing has two major benefits that underlie the current surge of ANS interest in industry, academia, and government. First, ANS devices can store large numbers of complex patterns—speech templates, visual scenes, robot movements, spatiotemporal behavior, social behavior, and so on. Second, ANS devices can classify new patterns to stored patterns quickly. Roughly speaking, neurocomputing devices classify patterns at a speed independent of the number of patterns stored. They immediately map input patterns to the nearest stored patterns. However, if they store too many patterns, classification accuracy degrades.

These two properties of neurocomputing resemble our ability to recognize familiar faces, aromas, and melodies at age 5 and at age 50 with roughly the same rapidity. We say the lawyer is quick on her feet if she accurately associates live testimony with obscure case precedents. We frequent the mechanic or physician who accurately diagnoses problems on the spot. We marvel at the cocktail-party pianist who plays from

continued

Bart Kosko was organizer of the IEEE First Annual International Conference on Neural Networks (ICNN-87) and is on the editorial board of Neural Networks. He received his masters in mathematics from the University of California at San Diego and his Ph.D. in electrical engineering from the University of California at Irvine. Dr. Kosko can be reached at Verac, 9605 Scranton Rd., San Diego, CA 92121.

Computers suffer from an inherent direct relationship between pattern number and search time: More patterns means a longer search.

memory any time upon request.

On the contrary, computer search time always depends on the number of stored patterns or templates. Computers suffer from an inherent direct relationship between pattern number and search time: more patterns, longer search. This is why they fail at real-time pattern recognition. And it is arguably why artificial intelligence researchers, after more than 20 years, have failed to build real-time pattern recognizers and sensory processors on serial or parallel computers.

Bidirectional Associative Memories

A BAM stores and recalls associations (A_i, B_i) that are learned by summing correlation matrices. This procedure superimposes the patterns to be learned on the same memory medium, much as data pairs can be superimposed on a hologram (as in optical BAMs). Recall that the encoding procedure places the associations (A_i, B_i) at or near system energy minima.

Each set of associations sculpts its own energy surface over the BAM state space. Associations are placed on the energy surface like rocks on a rubber sheet. Geometrically, it is clear that the number of energy minima does not affect the speed with which an input pattern rolls down the energy surface into a particular local minimum. Hence, no matter how big the BAM (whether it consists of 10 neurons or 10 billion neurons), it immediately converges to the nearest minimum.

The BAM is a two-field network of symmetrically interconnected neurons, as shown in figure 1. There are n neurons in $F_A = \{a_1, \dots, a_n\}$ and p neurons in $F_B = \{b_1, \dots, b_p\}$.

Each neuron is a simple nonlinear function. It transforms the sum of weighted input signals into a single output signal. In the simplest case, the output is binary, 1 or 0 (in general, a neuron's output signal continuously varies from 0 to 1). Stephen Grossberg of Boston University has proven mathematically that to accurately store and process distributed information in a neural network, this signal function must be a sigmoid or S-shaped function, such as $(1 + e^{-x})^{-1}$, and, indeed, the average firing frequency of real neurons is sigmoidal. The threshold function of a binary neuron is the limiting case of a steep continuous sigmoid function. This article assumes that the neurons in F_A and F_B are binary.

Each neuron turns on or off according to a threshold law. If the input to a neuron is positive, it turns on; if negative, off. When the input equals zero (threshold), the neuron maintains its current state; it

stays on if it is on, and off if off. The larger the threshold, the fewer the neurons that can turn on. Increasing the threshold of all neurons in a field in effect increases the competition within the field for activation.

If all neurons in a field apply the threshold law to their inputs simultaneously, the BAM is operating synchronously. Otherwise, it operates asynchronously, simulating a collection of independent, randomly operating neurons. For simplicity, you can assume synchronous operation. For instance, if six neurons in F_A receive the vector of inputs (6 -4 -1 8 -3 10), then the new F_A state is (1 0 0 1 0 1)—only neurons $a_1, a_4,$ and a_6 turn on.

BAM Encoding

Encoding is learning. A neural network learns by modifying the synapses between its neurons. In a BAM, all synaptic information is contained in an n -by- p connection matrix M . Every matrix M between F_A and F_B produces a stable BAM. All inputs quickly map to a pattern of stable reverberation. But different connection matrices encode different (A, B) associations as stable reverberations.

A BAM encodes a particular set of associations $\{(A_1, B_1), \dots, (A_m, B_m)\}$ by summing bipolar correlation matrices. This is an example of Hebbian, or correlation, learning. You can also interpret this method of encoding as Grossberg reciprocal outstar coding, in that each neuron in F_A and F_B fans out its output along modifiable pathways. The encoding scheme tends to place distinct associations (A_i, B_i) at or near local energy minima—provided you don't encode too many associations. You cannot reliably encode (store) and decode (recall) more patterns than the number n of neurons in field F_A or the number p of neurons in F_B , whichever is less; that is, given that you have m patterns, $m < \min(n, p)$. One way or another, the number of neurons in every neural network, artificial or biological, limits its storage capacity.

Bipolar vectors or matrices are binary vectors or matrices with -1s replacing 0s. The bipolar versions of the binary patterns $A_1 = (1 0 1 0 1 0)$ and $B_1 = (1 1 0 0)$ are $X_1 = (1 -1 1 -1 1 -1)$ and $Y_1 = (1 1 -1 -1)$. In general, X and Y denote the respective bipolar version of the binary vectors A and B . It can be shown that BAM correlation encoding improves if bipolar vectors and matrices are used instead of binary vectors and matrices.

The BAM encoding scheme converts each binary pair (A_i, B_i) to a bipolar pair

continued

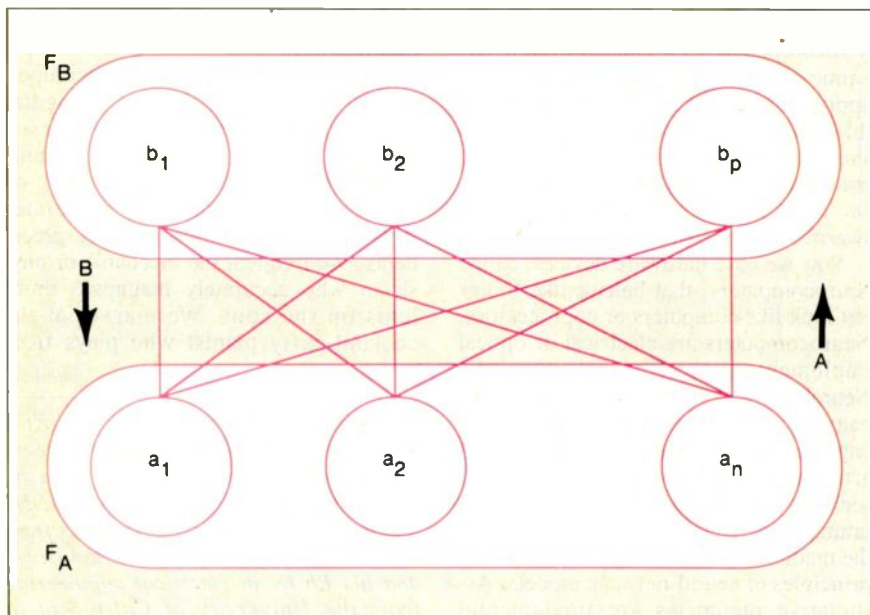

Figure 1: Topology of a BAM, showing the two fields of neurons connected by synapses.

frustrated
impatient
upset
tedious
dizzy
perplexed
crazy
dumb
outraged

aggravated
confused
perturbed
overwhelmed
defeated
stupid
annoyed
irate
foiled

sick
troubled
tired
miffed
agitated
wrecked
moronic
pained
thwarted

Don't hold back now. How do you really feel about working with columns?

Columns. The black hole of word processing technology.

Try to move a column with your present word processor. Good luck. Try to add or delete a column. Sorry.

Lotus Manuscript™ can change how you feel about working with columns. Really. Because Lotus Manuscript thinks vertically as well as horizontally.

Consider this. On ordinary word processors, when you create a table, or put any information in columns, you work horizontally, using tabs to create a vertical effect.

With our sophisticated table editor, you can actually create each column independent of one another. You can



Inserting a column with your present word processor would be a true test of patience, right?



It's simple with Manuscript, because Manuscript thinks vertically as well as horizontally.

change information, even delete, move or insert columns, without the usual litany of expletives deleted.

And it's not just limited to columns you create yourself. Take tables from Lotus® 1-2-3® or Symphony®, for instance. When you import that tabular information into Lotus Manuscript, it recognizes it as columns, so you can change, delete, move, insert or format this material as well. You can even dress up your tables with a variety of boxes and borders.

As you can see, Lotus Manuscript is not just another word processor. It's a complete document creation system, with more impressive features than

we could ever go into here.

Lotus Manuscript is designed to work on most IBM® PCs and compatibles.* Its familiar 1-2-3 interface makes it easy to use. And our Manuscript evaluation kit makes it easy to try. For \$10.00, you'll get a presentation disk, working software, and a tutorial manual. To get your evaluation kit, call 1-800-345-1043, ask for lot YS-1450. Or, for more information, see your Authorized Lotus Dealer, or write Lotus Development Corp., 90 Annex, Atlanta, GA 30390-03070.



Lotus Manuscript™

(X_i, Y_i) , converts each bipolar pair to a bipolar correlation matrix $X_i^T Y_i$, and then adds up the bipolar correlation matrices $M = X_1^T Y_1 + X_2^T Y_2 + \dots + X_m^T Y_m$ where the column vector X_i^T is the vector transpose of the row vector X_i . For example, if $X = (1 -1)$, then

$$X^T = \begin{pmatrix} 1 \\ -1 \end{pmatrix}$$

A special case of the BAM occurs when $F_A = F_B$ and all $A_i = B_i$. Then $M = M^T$ and the BAM collapses to symmetric unidirectional associative memory that stores the single patterns A_i in local energy minima. (The general continuous version of the symmetric unidirectional associative memory is known as the Cohen-Grossberg autoassociator; the special binary version is known as the Hopfield model.) Let's assume the general case where F_A and F_B are distinct.

Suppose you want to find the BAM that encodes the two binary associations

$$A_1 = (1 0 1 0 1 0) \quad B_1 = (1 1 0 0),$$

$$A_2 = (1 1 1 0 0 0) \quad B_2 = (1 0 1 0).$$

Note that this example does not strain the memory capacity, since $2 < \min(6, 4)$. Convert these binary pairs to bipolar pairs:

$$X_1 = (1 -1 1 -1 1 -1)$$

$$Y_1 = (1 1 -1 -1)$$

$$X_2 = (1 1 1 -1 -1 -1)$$

$$Y_2 = (1 -1 1 -1)$$

Convert these two bipolar vector pairs to two bipolar correlation matrices:

$$X_1^T Y_1 = \begin{pmatrix} 1 & 1 & -1 & -1 \\ -1 & -1 & 1 & 1 \\ 1 & 1 & -1 & -1 \\ -1 & -1 & 1 & 1 \\ 1 & 1 & -1 & -1 \\ -1 & -1 & 1 & 1 \end{pmatrix}$$

$$X_2^T Y_2 = \begin{pmatrix} 1 & -1 & 1 & -1 \\ 1 & -1 & 1 & -1 \\ 1 & -1 & 1 & -1 \\ -1 & 1 & -1 & 1 \\ -1 & 1 & -1 & 1 \\ -1 & 1 & -1 & 1 \end{pmatrix}$$

Note that the j th row of the i th correlation matrix $X_i^T Y_i$ is simply Y_i multiplied by the j th element of X_i , and that the j th column is simply X_i multiplied by the j th element of Y_i . So correlation matrices can be written down directly when given bipolar associations. Then M is given by $M = X_1^T Y_1 + X_2^T Y_2$:

$$M = \begin{pmatrix} 2 & 0 & 0 & -2 \\ 0 & -2 & 2 & 0 \\ 2 & 0 & 0 & -2 \\ -2 & 0 & 0 & 2 \\ 0 & 2 & -2 & 0 \\ -2 & 0 & 0 & 2 \end{pmatrix}$$

This synaptic matrix encodes my particular computational problem; namely, storing (A_1, B_1) and (A_2, B_2) in a parallel distributed network. The matrix element m_{ij} indicates the symmetric (distance-dependent) synapse between neurons a_i and b_j . The synapse is excitatory if $m_{ij} > 0$, inhibitory if $m_{ij} < 0$. (Try drawing the BAM network topology obtained with this matrix M .)

You can erase association (A_i, B_i) from M by adding $-X_i^T Y_i$ to M . This is equivalent to encoding (A_i, B_i^c) or (A_i^c, B_i) , where the superscript c denotes complement. The complement of $(0 1 1 0 0)$, for instance, is $(1 0 0 1 1)$. This is true because you obtain the complement of a bipolar vector by multiplying the vector by -1 . A little thought then shows that when you encode (A_i, B_i) in M , you encode (A_i^c, B_i^c) in M as well, and vice versa.

The BAM energy E of association or state (A_i, B_i) is $-A_i M B_i^T$. In the example, $E(A_1, B_1) = E(A_2, B_2) = -6$. (In upcoming examples, you'll see that the BAM encoding algorithm placed (A_1, B_1) and (A_2, B_2) in local energy minima.)

BAM Decoding

BAM decoding is associative recall. Say an input pattern A is presented to BAM field F_A . The n neurons across F_A are turned on or off according to whether the corresponding binary values of A are 1 or 0. Each neuron a_i in F_A fans out its binary value across the p pathways as if pouring water into a pipeline system. The synaptic value m_{ij} multiplies, or "gates," the binary value a_i . Each neuron b_j in F_B receives a fan-in of input products $a_i m_{ij}$ from each of its n synaptic connections; b_j then behaves as an OR gate, since any neuron in F_A can activate it. Neuron b_j sums its input across all connections, $a_1 m_{1j} + a_2 m_{2j} + \dots + a_n m_{nj}$, then thresholds this sum to generate its output binary signal. If the input sum exceeds b_j 's threshold, which I assume is 0, then b_j 's output is 1. If it is less than threshold, b_j 's output is 0. If it equals threshold, b_j maintains its current state. Neuron b_j then fans out its output signal across the n pathways m_{ij} to each neuron a_i in F_A . This means F_B uses the transpose memory M^T to send information, while F_A uses M .

Each a_i then generates its binary signal from all its summed inputs and sends it back to F_B . And round and round the BAM goes. Fortunately, it is a mathematical theorem that the BAM always rapidly converges, so it will not oscillate chaotically forever. (Exercise: Show that a state change in F_A or F_B and the threshold signal law forces the energy E to decrease, and that E cannot decrease forever. This is sufficient to prove that any matrix M

continued

Listing 1: Pseudocode for a BAM demonstration program written in BASIC.

- Step 1. For all i, j clear $M(i, j)$, $A(i)$, $B(i)$. This is an initialization step.
- Step 2. Get input into $A()$ and $B()$ for an association to be learned.
The input will have only two possible values, 0 or 1.
- Step 3. Learn the desired input association.
 - a. Build $X(i)$ for $A(i)$ where $X(i) = -1$ if $A(i) = 0$ and $X(i) = 1$ if $A(i) = 1$;
 - b. Build $Y(i)$ from $B(i)$ where $Y(i) = -1$ if $B(i) = 0$ and $Y(i) = 1$ if $B(i) = 1$;
 - c. For all i, j , build $M(i, j) = M(i, j) + X(i) * Y(j)$.
- Step 4. If there is another association to learn, go to step 2.
- Step 5. Input a new $A()$ and $B()$ to be run on the network.
The input for each element will have the values 0 or 1.
- Step 6. Run the A to B iteration of the network.
 - a. The new $B(j) = 1$ if the sum of $A(i) * M(i, j)$ for all i is greater than the 0 threshold;
 - b. The new $B(j) = 0$ if the sum of $A(i) * M(i, j)$ for all i is less than the 0 threshold;
 - c. The new $B(j)$ is unchanged if the sum of $A(i) * M(i, j)$ for all i is equal to the 0 threshold.
- Step 7. Run the B to A iteration of the network.
 - a. The new $A(i) = 1$ if the sum of $B(j) * M(i, j)$ for all j is greater than the 0 threshold;
 - b. The new $A(i) = 0$ if the sum of $B(j) * M(i, j)$ for all j is less than the 0 threshold;
 - c. The new $A(i)$ is unchanged if the sum of $B(j) * M(i, j)$ for all j is equal to the 0 threshold.
- Step 8. Repeat steps 6 and 7 until there are no changes in $A()$ and $B()$.
- Step 9. Display the results.

The single best way to turn your PC-AT into a multi-user system.



Introducing the Wyse WY-60.

Now there's a perfectly compatible, reliable, economical, Wyse way to get multi-user mileage from your PC-AT. Wyse WY-60 terminals give you complete compatibility for your IBM Personal Computer AT systems, right down to the exact keyboard layout, character set and display features.

The only thing different is how much cleaner and more readable your information is with the WY-60's high resolution and flat, non-glare, 14" tilt/swivel screen.

Multiple display formats go up to 132 columns and 44 lines on one screen, to get the most out of applications such as Multiplan and WordStar.

And a 512-character downloadable soft font is also there when you need mathematical symbols or customized character sets.

The adjustable arm is optional, and you can choose a green, white or amber screen.

No wonder we ship more terminals than anybody but IBM.*

Call toll-free or write, today, for more information. Wyse Technology, Attn: Marcom Department 60-AT, 3571 N. First St., San Jose, California 95134.

Call 1-800-GET-WYSE

WYSE

YOU NEVER REGRET A WYSE DECISION.

Wyse is a registered trademark of Wyse Technology. WY-60 and the "V" shaped design are trademarks of Wyse Technology. IBM and IBM Personal Computer AT are trademarks of International Business Machines Corporation. WordStar is a registered trademark of MicroPro International. Multiplan is a registered trademark of Microsoft Corporation. © 1986 Wyse Technology. *Dataquest 1985 terminal shipment update.

Inquiry 318

produces a stable BAM.)

BAM decoding is easier done than said. Returning to the example, let's see if the memory matrix M actually stores the pairs (A_1, B_1) and (A_2, B_2) . You do this by presenting A_1 to the BAM and observing whether (A_1, B_1) is recalled. If it is, then either A_1 or B_1 will recall (A_1, B_1) . Repeat this test for A_2 and B_2 .

Vector-matrix multiplication summarizes BAM forward and backward information flow. Forward flow proceeds through M , and backward through M^T . The row vector $AM = (4 \ 2 \ -2 \ -4)$ is the vector of fan-in inputs received by F_B . The threshold-signal law then yields $(4 \ 2 \ -2 \ -4) \rightarrow (1 \ 1 \ 0 \ 0) = B_1$, since you are synchronously updating all neurons in

F_B . So A_1 evoked B_1 . B_1 then sends an M^T -filtered vector of signals back to F_A : $BM^T = (2 \ -2 \ 2 \ -2 \ 2 \ -2) \rightarrow (1 \ 0 \ 1 \ 0 \ 1 \ 0) = A_1$. If you now push A_1 through M again, B_1 results, which again evokes A_1 , and so on forever. Thus, the short-term-memory pattern (A_1, B_1) reverberates across the BAM. It is a stable equilibrium point of the dynamic system. Put another way, both A_1 and B_1 recall the stored association (A_1, B_1) . Similarly, $A_2M = (4 \ -2 \ 2 \ -4) \rightarrow (1 \ 0 \ 1 \ 0) = B_2$, and $B_2M^T = (2 \ 2 \ 2 \ -2 \ -2 \ -2) \rightarrow (1 \ 1 \ 1 \ 0 \ 0 \ 0) = A_2$. So (A_2, B_2) is also stored as a stable point. An instructive exercise would be to see how many synapses in M you can remove or change without affecting these stable reverberations.

The BAM is error-correcting. Partial or noisy patterns tend to recall complete patterns. For example, the input $A = (0 \ 1 \ 1 \ 0 \ 0 \ 0)$ is just A_2 perturbed by 1 bit. Then $AM = (2 \ -2 \ 2 \ -2) \rightarrow (1 \ 0 \ 1 \ 0) = B_2$, and thus A evokes the resonant pair (A_2, B_2) . Note that (A, B_2) has energy $E(A, B_2) = -4 > -6 = E(A_2, B_2)$, evidence that the BAM encoding procedure placed (A_2, B_2) at a local energy minimum.

Suppose you add the new association (A_3, B_3) to the BAM memory M , where $A_3 = (1 \ 1 \ 0 \ 0 \ 1 \ 1)$ $B_3 = (0 \ 1 \ 1 \ 1)$. This strains the BAM's storage capacity but does not exceed it. Geometrically, when you store only a few association patterns (A, B) , each forms a large basin of attraction

continued

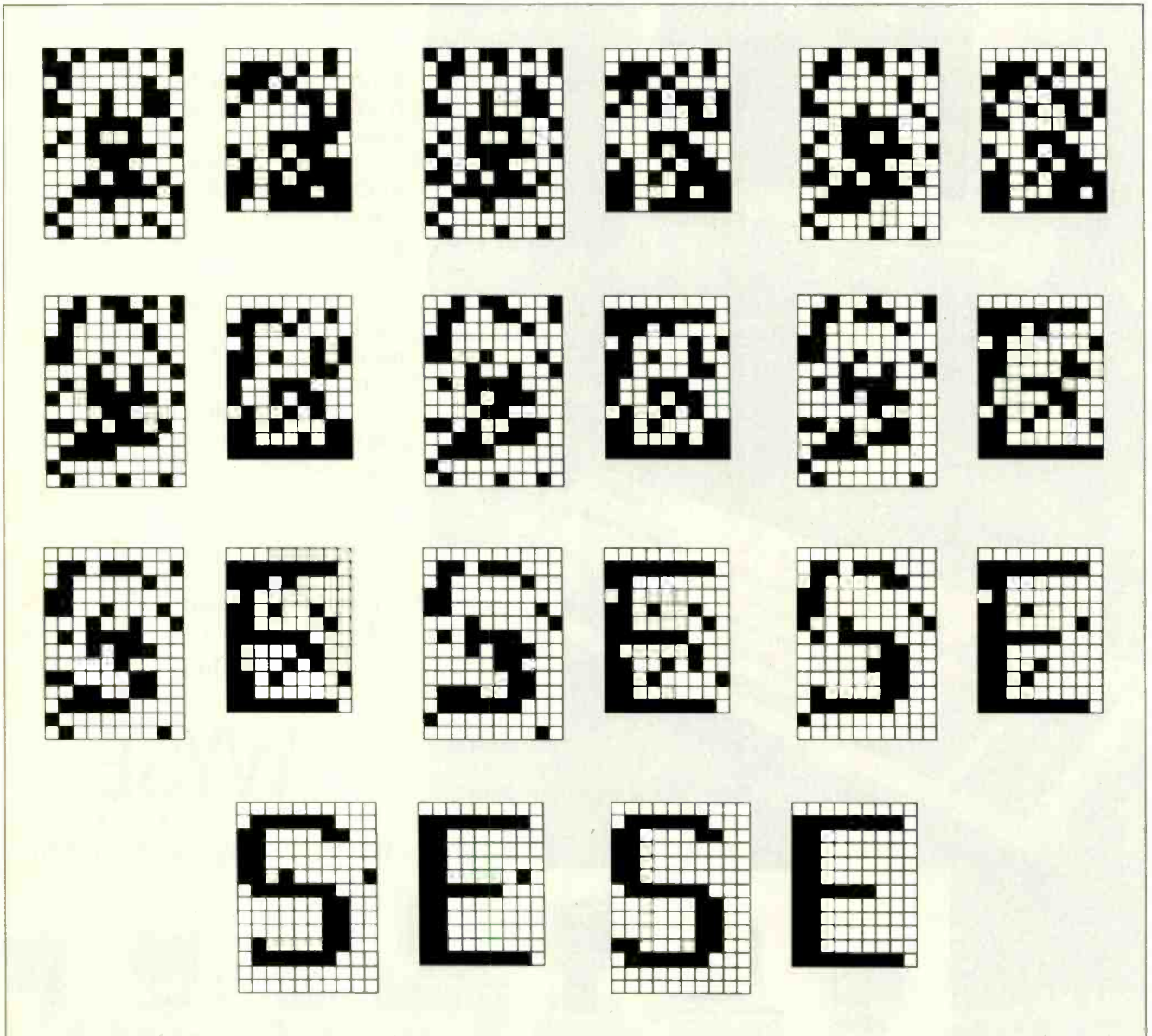

Figure 2: Asynchronous recall in a BAM consisting of two fields of neurons, one containing 140 neurons and another containing 108 neurons.



Finally. A Portable Designed To Break The Mold, Instead Of Your Back.

Portable computers fit a predictable pattern. The more powerful they are, the less portable they are.

With one magnificently small exception. The T3100/20.

It's the best shape power has ever been in. A smaller, slimmer profile that's tailored to you, instead of the other way around.

Yet inside this sleek 15-pound package are 640KB of RAM and a built-in 20MB hard disk. All driven by an 80286 microprocessor, the same CPU that sparks the IBM® PC AT.*

Its gas plasma screen is so bright, it looks like a full-size CRT display. Which, by the way, you can easily plug into the T3100/20's standard RGB color port.

MS-DOS® 3.2 is standard. So are parallel, serial and 5¼" external drive ports. And a soft carrying case.

With every T3100/20, we'll include free copies of Lotus® Symphony®* and Lotus Metro®, two of the world's most popular programs, for the world's

most popular portable computer:

You can also add a 1200 bps Hayes® compatible modem, a five-slot IBM-compatible expansion chassis, 2 megabytes of extended memory, and a numeric keypad.

The T3100/20 is backed by Exceptional Care,** our promise that if we have to fix your computer, we'll fix you up with another one while you wait.

All of which leads one to a small dilemma. How to regard a machine that changes forever the way the world thinks about portable performance.

You could think of it as a desktop on a crash diet. Or the muscle of an AT without the bulk. Or simply as *PC World* put it: "A small miracle."

Call 1-800-457-7777 for the Toshiba computer and printer dealer nearest you. He can show you how to enjoy all the advantages of power.

With none of the burdens.

IBM & PC AT are registered trademarks of International Business Machines Corporation. MS-DOS is a registered trademark of Microsoft Corp. Lotus, Symphony and Metro are registered trademarks of Lotus Development Corp. Hayes is a registered trademark of Hayes Corp. *Limited time offer. **No-cost enrollment required. See your dealer for details.

In Touch with Tomorrow
TOSHIBA

Toshiba America, Inc. Information Systems Division

tion in the BAM state space. As you add more patterns to the BAM, the basins increase in number but shrink in diameter and depth. The BAM recognizes fewer input patterns by stored associations. Worse, spurious attractor basins can emerge, causing misclassification. When this happens, the BAM experiences a type of déjà vu, since it remembers something it never learned.

In this case, the new memory $M = X_1^T Y_1 + X_2^T Y_2 + X_3^T Y_3$ is given by

$$M = \begin{pmatrix} 1 & 1 & 1 & -1 \\ -1 & -1 & 3 & 1 \\ 3 & -1 & -1 & -3 \\ -1 & -1 & -1 & 1 \\ -1 & 3 & -1 & 1 \\ -3 & 1 & 1 & 3 \end{pmatrix}$$

When you retest to see if (A_1, B_1) and (A_2, B_2) are still stable points, you'll find that they are, since $E(A_1, B_1) = E(A_2, B_2) = -6$. To test A_3 , $A_3 M = (-4\ 4\ 4\ 4) \rightarrow (0\ 1\ 1\ 1) = B_3$, and $B_3 M^T = (1\ 3\ -5\ -1\ 3\ 5) \rightarrow (1\ 1\ 0\ 0\ 1\ 1) = A_3$. So (A_3, B_3) is also a resonant stable point, but with energy that's twice as small, namely, $E(A_3, B_3) = -12$. Since (A_3, B_3) is a deeper basin, you can expect it to attract and classify more patterns. The unit input $(1\ 1\ 1\ 1\ 1\ 1)$, which is 1 bit closer to A_3

than to A_1 or A_2 , recalls (A_3, B_3) . But if you flip the last bit, the new input $(1\ 1\ 1\ 1\ 1\ 0)$ misclassifies to a spurious association (A, B) , where $A = (1\ 1\ 1\ 0\ 1\ 0)$ and $B = (1\ 1\ 1\ 0)$, also with energy $E(A, B) = -6$. Such misclassification reflects that you have almost overstuffed the BAM memory matrix M .

If you'd like to experiment with the above algorithm, Duane DeSieno, Rod Taber, and Joel Davis have provided programs in BASIC, Pascal, and C. [Editor's note: *These programs are available on disk, in print and on BIX; see the card following page 256 for details. They are also available from BYTEnet listings; see page 4.*] Listing 1 shows pseudocode for the BASIC program.

Asynchronous BAM Recall

Figure 2 illustrates asynchronous BAM recall. Field F_A contains $n = 10 \times 14 = 140$ neurons. F_B contains $p = 9 \times 12 = 108$ neurons. Both vector fields are arranged as binary matrices to help the eye detect interesting spatial patterns. The BAM stores the three alphabetic associations: (M, V) , (S, E) , and (G, N) . A 40 percent noise-corrupted version (99 bits randomly flipped) of (S, E) is presented to the BAM. Figure 2 shows 11 snapshots of the asynchronous recall process. At

each clock cycle, roughly six randomly chosen neurons are allowed to make update (state-change) decisions. This is a cross-sectional approximation of a stochastic neural process—a set of independent neurons, each randomly updating in time.

Different random-update choices produce different asynchronous-recall trajectories. In this BAM, most trajectories recall the desired nearest stored association, since the memory capacity is not strained and the spatial patterns all differ significantly. In figure 2, (S, E) is perfectly recalled, as the neurons independently proceed from local chaos to global order—without any neuron aware of its global effects. The anarchical neurons are guided as if by an invisible hand to correct global system errors without knowing that such errors have occurred and need to be corrected.

Finally, BAMs are perhaps best implemented in optics, with photons instead of electrons. Neurons in fields F_A and F_B can be totally interconnected to each other with simple lenses. Using resistors to interconnect amplifiers is much more difficult, space consuming, and expensive. Unlike electrical pathways, optical-interconnect beams can pass through one another without interference. ■

For More Information

Associative-memory literature is mathematical, interdisciplinary, and vast. McCulloch and Pitts introduced the first Boolean switching-function neurons in 1943. Kohonen largely pioneered the study of correlation-matrix memories. His 1984 book is a standard in the field. Steinbuch put forth the idea of stable points in crossbar associative networks in his 1961 "learning matrix."

Amari et al first made the rigorous connection between associative networks and thermodynamics. Hopfield next made the connection between stable points and energy minima by establishing an isomorphism between symmetric binary networks and the Ising spin-glass model of ferromagnetism in statistical mechanics. Grossberg et al have proven all of the above and more with rigorous mathematics. With Carpenter, Grossberg developed the adaptive resonance model that, in some sense, an adaptive BAM approximates.

Grossberg's 1982 and 1987 volumes are the Old and New Testaments of neural networks—read them. I developed the BAM and have extended it to real-time unsupervised learning. The 1986

volumes of Rumelhart and McClelland provide an accessible introduction to neural networks from a cognitive-science perspective.

FOR FURTHER READING

- Amari, S., K. Yoshida, and K. Kanatani. "A Mathematical Foundation for Statistical Neurodynamics." *SIAM Journal of Applied Mathematics*, vol. 33, no. 1, pages 95–126. July 1977.
- Carpenter, G. A., and S. Grossberg. "A Massively Parallel Architecture for a Self-Organizing Neural Pattern Recognition Machine." *Computer Vision, Graphics, and Image Processing*, vol. 37, pages 54–116, 1987.
- Cohen, M., and S. Grossberg. "Absolute Stability of Global Pattern Formation and Parallel Memory Storage by Competitive Neural Networks." *IEEE Transactions on Systems, Man, and Cybernetics*, SMC-13, pages 815–926, 1983.
- Grossberg, S. *Studies of Mind and Brain*. Boston: Reidel Press, 1982.
- Grossberg, S. *The Adaptive Brain, I & II*. Amsterdam: North-Holland, 1987.

- Hopfield, J. J. "Neural Networks and Physical Systems with Emergent Collective Computational Abilities," *Proceedings of the National Academy of Sciences, USA*, vol. 79, pages 2554–2558, April 1982.
- Kohonen, T. *Self-Organization and Associative Memory*. New York: Springer-Verlag, 1984.
- Kosko, B. "Bidirectional Associative Memories," *IEEE Transactions on Systems, Man, and Cybernetics*, Fall 1987.
- Kosko, B., and C. Guest. "Optical Bidirectional Associative Memories." *Proc. SPIE: Image Understanding*, vol. 758, January 1987.
- McCulloch, W. S., and W. Pitts. "A Logical Calculus of the Ideas Immanent in Nervous Activity." *Bulletin of Mathematical Biophysics*, vol. 5, pages 115–133, 1943.
- Rumelhart, D. E., and J. L. McClelland, eds. *Parallel Distributed Processing, I & II*. Cambridge, MA: MIT Press, 1986.
- Steinbuch, K. "Die Lernmatrix," *Kybernetik (Biological Cybernetics)*, vol. 1, pages 36–45, 1961.

I N T R O D U C I N G
T H E P E R F E C T M O N I T O R

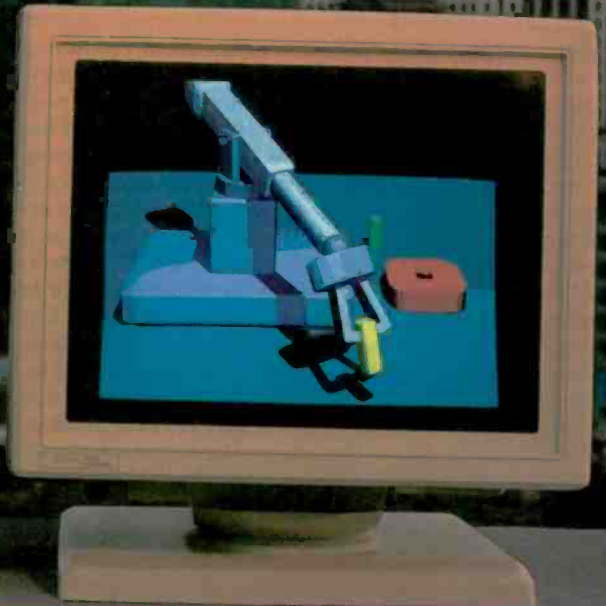

ZCM-1490

FREE...Perfect Monitor Comparison Kit.

Return this card or call today: 1-800-553-0305
Offer expires: December 31, 1987

YES. I want to preview the most important innovation since the computer. Send my Kit today, including viewfinder and four-color slides.

NOTE: To receive your FREE Kit, you must complete the information below:

Name _____ Title _____

Company Name _____

Address _____ City _____ State _____

Zip Code _____ Phone # (_____) _____

Product usage: Business Personal

Application (e.g., Graphics, spreadsheet, etc.) _____

Purchase Time Frame: Within 1 month Within 1-3 months Within 3-6 months Over 6 months

Purchase Quantity: Single purchase 2-20 units 21-50 units 51-100 units Over 100 units

What best describes your involvement in the purchase decision? (Check any that apply.)

Recommend Influence Purchase
Are you interested in a product demonstration? Yes No

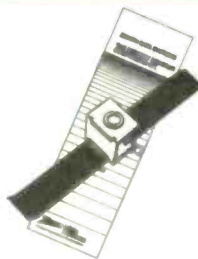

Perfect Monitor Comparison Kit

if you can't wait, call today:
800-553-0305.

Offer expires 12/31/87.

Zenith Data Systems is a registered trademark of IBM Corp.

ZENITH | data systems

QUALITY GOES IN BEFORE THE NAME GOES ON*

SEPTEMBER 1987 • B Y T E 145

Karmarkar's Algorithm

A method for solving large linear programming problems

[Editor's note: This is easily the most mathematically advanced article we've done in *BYTE*. Readers might remember Andrew Rockett and John Stevenson as two of the three authors of a two-part article (August and September 1980 issues) on Khachiyan's algorithm, another algorithm for linear programming that turned out to be sound in theory but unusable in practice.

Here is my attempt to summarize the important points this article makes. First, it describes Karmarkar's algorithm, how it works, and why it's valid in the theoretical sense. It does not, however, include a modification of the algorithm (included in Karmarkar's original paper) that makes its implementation feasible for large problems being solved on mainframe computers.

Second, the classic simplex method for solving linear programming problems differs from Karmarkar's algorithm in that the former stops when it has found the absolute best solution, while the latter stops when it finds an answer that is a set factor better than the initial guess; this is assumption (C) of problem type (4) in the section "Karmarkar's Restricted Problem." This means that the choice of the initial guess greatly influences the accuracy and validity of the final answer.

Third, Karmarkar's algorithm does not directly solve linear programming problems. Instead, it attempts to minimize a given function (called the objective function) within an n -dimensional "triangular" region called a simplex. (See "Concepts from Linear Algebra" on page 147 for more detailed definitions.) It turns out that we can map the problem space of the linear programming problem (which is called an n -dimensional orthant) into a simplex, solve the problem using Karmarkar's algorithm, then get the final answer by mapping the solution back into the orthant that represents the original problem. (Figure 4 shows a geometric representation of how the orthant maps into the simplex.)

Figures 2 and 3 show a geometric visualization of how Kar-

markar's algorithm works. In figure 2, we start with the point \mathbf{a}_0 in the center of the circle, knowing that the solution is at one of the endpoints of the line it's on. The first part of Karmarkar's algorithm takes us to a better approximation to the answer, $\mathbf{x}^{(1)}$, which lies between \mathbf{a}_0 and one of the two points at the intersection of the line \mathbf{a}_0 is on and the inscribed circle. (In general, we will use lowercase boldfaced letters to indicate column vectors only, while uppercase boldfaced letters will indicate matrices of arbitrary size; scalars will be italicized.) Karmarkar's theorem proves that, by limiting your step to one-fourth the size of the "step" that is possible at this point, you can guarantee under all circumstances a certain minimum improvement. This is discussed under "The Main Theorem."

Figure 3 shows how Karmarkar's algorithm iterates from one approximation to the next. A "better" point $\mathbf{x}^{(k)}$ is projected into the \mathbf{a}_0 center of another simplex (triangular region). The work of figure 2 is repeated in this second simplex, and the better approximation it produces, \mathbf{a}^* , is then mapped back into the first simplex, resulting in a still better approximation, $\mathbf{x}^{(k+1)}$. This process is repeated a given number of times to get the final approximation, $\mathbf{x}^{(m)}$, which is then transformed into the original orthant to get the final result.

It turns out that you can calculate the number of iterations, m , needed to improve the initial estimate by the factor desired (see "The Main Theorem" below for the equation for m). If, after m iterations, the calculated results don't show the desired improvement, the problem is infeasible and has no solution.

"Nonzero Objective Functions" and later sections describe strategies for taking away certain restrictions that limit the problems Karmarkar's algorithm can solve. These sections also discuss the problem of feasibility and the use of Karmarkar's algorithm in real-world situations.]

—Gregg Williams, Senior Technical Editor

In the fall of 1984, a new mathematical technique briefly became front page news. The *New York Times* called it a "breakthrough in problem solving," while *Time* magazine described a "major math breakthrough" in an "abstruse branch of mathematics known as linear programming." The method was devised by Narendra K. Karmarkar at AT&T's Bell Laboratories in New Jersey. Unlike Khachiyan's algorithm, an-

other new way of solving linear programming problems, Karmarkar's algorithm had already demonstrated its worth: An article in the September 21, 1984, issue of *Science* reported that an implementation of the algorithm outperformed one implementation of the classic simplex method by a factor of over 50 on medium-scale problems of 5000 variables.

In this article, we shall place Karmarkar's algorithm in the context of linear programming theory relative to the simplex method, given both geometric and algebraic descriptions of the procedure and an indication of why it works. Then we will explain how to reduce a general linear programming problem to the restricted form actually solved by Karmarkar and mention

Drs. Andrew M. Rockett and John C. Stevenson can be reached through the Department of Mathematics, C. W. Post Campus, Long Island University, Greenvale, NY 11548.

some implementation considerations. Our presentation is based on Karmarkar's paper "A New Polynomial-Time Algorithm for Linear Programming" (*Combinatorica*, vol. 4, 1984, pages 373-395). We will illustrate several points with example problems and BASIC programs that solve them.

LP Problems and the Simplex Method

By a linear programming (LP) problem we mean a problem of the form

$$(1) \quad \begin{array}{l} \text{minimize } \mathbf{c}^T \mathbf{x} \\ \text{subject to } \mathbf{A} \mathbf{x} \geq \mathbf{b} \text{ and } \mathbf{x} \geq \mathbf{0} \end{array}$$

where \mathbf{c} and \mathbf{x} are vectors in R^n , \mathbf{A} is an m by n matrix, and \mathbf{b} is a vector in R^m . The objective function is $\mathbf{c}^T \mathbf{x}$, and the conditions $\mathbf{A} \mathbf{x} \geq \mathbf{b}$ and $\mathbf{x} \geq \mathbf{0}$ are the constraints. Given (1), there is a corresponding maximization problem called the dual problem:

$$(2) \quad \begin{array}{l} \text{maximize } \mathbf{b}^T \mathbf{y} \\ \text{subject to } \mathbf{A}^T \mathbf{y} \leq \mathbf{c} \text{ and } \mathbf{y} \geq \mathbf{0} \end{array}$$

The solutions of these problems are related, as you can see by noticing that $\mathbf{b}^T \mathbf{y} \leq (\mathbf{A} \mathbf{x})^T \mathbf{y} = \mathbf{x}^T (\mathbf{A}^T \mathbf{y}) \leq \mathbf{x}^T \mathbf{c} = \mathbf{c}^T \mathbf{x}$. So the maximization problem seeks to increase $\mathbf{b}^T \mathbf{y}$ as much as possible, while the minimization problem seeks to decrease $\mathbf{c}^T \mathbf{x}$, which is always greater than or equal to $\mathbf{b}^T \mathbf{y}$. Consequently, if a solution can be found, it must occur when $\mathbf{b}^T \mathbf{y} = \mathbf{c}^T \mathbf{x}$.

The *simplex method* is a linear programming algorithm that solves both the original problem and the dual problem at the same time. To apply the simplex method to problem (1), first we rewrite the problem as

$$(3) \quad \begin{array}{l} \text{minimize } \mathbf{c}^T \mathbf{x} \\ \text{subject to } \mathbf{A} \mathbf{x} = \mathbf{b} \text{ and } \mathbf{x} \geq \mathbf{0} \end{array}$$

where now the vector \mathbf{x} is in R^{n+m} . The m additional components are called *slack variables* since each of the m inequalities in the original constraint $\mathbf{A} \mathbf{x} \geq \mathbf{b}$ requires one slack variable $s_k \geq 0$ to transform the k th inequality $\mathbf{A}_k \mathbf{x} \geq b_k$ into an equality $\mathbf{A}_k \mathbf{x} - s_k = b_k$. The vector \mathbf{c} and the matrix \mathbf{A} of (3) are obtained from those of (1) by extending the old \mathbf{c} with m zeros and by adjoining $-\mathbf{I}_m$ to the old \mathbf{A} . Although (3) at first seems to be a trivial reformulation of (1), it is not, since the m slack variables are closely related to the variables we called \mathbf{y} in the dual problem (2). Moreover, we now know a basic point $\mathbf{x}^{(0)}$ that satisfies $\mathbf{A} \mathbf{x} = \mathbf{b}$ in (3), since $\mathbf{x}^{(0)}$ can be obtained by setting $\mathbf{x}_k^{(0)} = 0$ for $k = 1, \dots, n$ and $\mathbf{x}_k^{(0)} = -b_k$ for $k = 1, \dots, m$. [Editor's note: $\mathbf{x}^{(0)}$ is an $(n+m)$ -dimensional vector of $R^{(n+m)}$; the superscript (0) is used to denote that it is the first true value of an iterated sequence of points $\mathbf{x}^{(0)}, \mathbf{x}^{(1)}, \mathbf{x}^{(2)}, \dots$. The k th component of this vector is the value $\mathbf{x}_k^{(0)}$.] If $\mathbf{x}^{(0)} \geq \mathbf{0}$, it is called a *basic feasible point*, since it satisfies the constraints of (3).

"Stage one" of the simplex method transforms a basic point into a basic feasible point, then "stage two" moves to successively better (in terms of the objective function) basic feasible

points until the minimum of the objective function is reached. Since there are a finite number of basic feasible points, the simplex method will either find the solution or detect the nonsolvability of the problem in a finite number of steps. Unfortunately, the number of basic feasible points increases rapidly as the number of variables increases, and it is possible to construct problems that trick the simplex method into visiting almost all possible basic feasible points before reaching the optimum point. (See the version of the "Klee-Minty problem" included in Part 2 of our article on Khachiyan's algorithm in the September 1980 BYTE.)

Thus the worst-case performance of the simplex method is exponential in n , the number of variables. We shall write this as $O(e^n)$; the Bachmann-Landau order notation $f(n) = O(g(n))$ means that

$$\lim_{n \rightarrow \infty} \left| \frac{f(n)}{g(n)} \right| \leq K$$

where K is a constant independent of n . Put another way, for large n if you double the size of the problem, the running time will be multiplied by e^n , and e^n gets large very fast!

In spite of the worst-case performance, the simplex method has worked well in practice. Since most computer implementa-

continued

Concepts from Linear Algebra

If \mathbf{x} is a column vector in the n -dimensional real vector space R^n , then the transpose of \mathbf{x} is the row vector $\mathbf{x}^T = (x_1, x_2, \dots, x_n)$. The vector \mathbf{e} is the special vector such that $\mathbf{e}^T = (1, \dots, 1)$. We shall write $\mathbf{x} \geq \mathbf{0}$ when $x_k \geq 0$ for $k = 1, \dots, n$. Then the positive n -dimensional orthant $P_+^n \subset R^n$ consists of all $\mathbf{x} \in R^n$ with $\mathbf{x} \geq \mathbf{0}$. The length of the vector \mathbf{x} will be denoted $|\mathbf{x}|$.

Given a vector $\mathbf{x} \in R^n$, the diagonal matrix of \mathbf{x} is the n by n matrix $\mathbf{D} = \mathbf{D}(\mathbf{x})$ consisting of the elements of \mathbf{x} down the diagonal and zeros everywhere else. $\mathbf{D}(\mathbf{e})$ is called the (n -dimensional) identity matrix and will be denoted by \mathbf{I}_n . The inverse of a square matrix \mathbf{A} is \mathbf{A}^{-1} and $\mathbf{A} \mathbf{A}^{-1} = \mathbf{A}^{-1} \mathbf{A} = \mathbf{I}_n$.

The solutions of a homogeneous system of linear equations $\mathbf{A} \mathbf{x} = \mathbf{0}$ form a linear subspace $\Omega = \{\mathbf{x} \mid \mathbf{A} \mathbf{x} = \mathbf{0}\}$ of R^n that contains the origin and is of dimension less than n if the matrix \mathbf{A} is not trivial. The solutions of an inhomogeneous system of linear equations $\mathbf{A} \mathbf{x} = \mathbf{b}$ are translates of the solutions of the corresponding homogeneous equation since, given any particular solution \mathbf{x}_0 with $\mathbf{A} \mathbf{x}_0 = \mathbf{b}$, then for any \mathbf{x} with $\mathbf{A} \mathbf{x} = \mathbf{0}$ we see that $\mathbf{A}(\mathbf{x}_0 + \mathbf{x}) = \mathbf{b}$.

The n -sphere S^n is contained in R^{n+1} and is $\{\mathbf{x} \mid \sum x_i^2 = 1\}$. Thus S^0 consists of the two points $+1$ and -1 on the real line R , S^1 is the unit circle in the plane R^2 , and S^2 is the "usual" sphere in the three-dimensional space R^3 .

Similarly, the n -simplex Δ^n is contained in R^{n+1} and is $\{\mathbf{x} \mid \sum x_i = 1 \text{ and } \mathbf{x} \geq \mathbf{0}\}$. Thus Δ^0 is the point $+1$ on the real line, Δ^1 is the diagonal line segment from $(0, 1)$ to $(1, 0)$ in the plane, and Δ^2 is the triangle in R^3 connecting $(0, 0, 1)$, $(0, 1, 0)$ and $(1, 0, 0)$ (see figure 1 for an example). The center of the n -simplex will be denoted by the vector \mathbf{a}_0 such that $\mathbf{a}_0^T = (1/(n+1), \dots, 1/(n+1))$.

tions use finite-precision arithmetic, the possibility of "cycling" due to degeneracy is practically eliminated because of the perturbation caused by round-off errors while proper scaling of the initial problem removes the pitfalls of the Klee-Minty problem. (As far as we are aware, all known Klee-Minty problems depend on scaling tricks to create their effect.)

Karmarkar's Restricted Problem

Karmarkar's algorithm does not solve the linear programming problems (1), (2), or (3) but rather the restricted problem

$$(4) \quad \begin{aligned} &\text{minimize } c^T x \\ &\text{subject to } x \in \Omega \cap \Delta^n \end{aligned}$$

where $c, x \in R^{n+1}$ and $\Omega = \{x \mid Ax = 0\}$ is the solution space of a homogeneous system of linear equations and Δ^n is the n -dimensional simplex contained in R^{n+1} (see the text box "Concepts from Linear Algebra."). We shall make three assumptions about problem (4):

- (A) the minimum value of the objective function is zero;
- (B) the problem is feasible and the center a_0 of the simplex Δ^n is a feasible point (i.e., $a_0 \in \Omega$); and
- (C) a termination parameter $q > 0$ is given, and we will accept the problem as solved when we obtain a feasible point x with

$$\frac{c^T x}{c^T a_0} \leq 2^{-q}.$$

Minimizing the Objective Function

Suppose we wish to minimize $c^T x$ where x is on a sphere S centered at a point a . Since the solutions of $c^T x = 0$ are the vectors x that are perpendicular to the vector c at the origin, the solutions of $c^T x = K$ form a family of lines parallel to the solutions of $c^T x = 0$. If $K > 0$ the displacement is in the direction of c , while if $K < 0$ the displacement is in the opposite direction. It now becomes clear that the point on S that minimizes $c^T x$ is x^* , the intersection of the circle with the vector $-c$ drawn from the center a (see figure A).

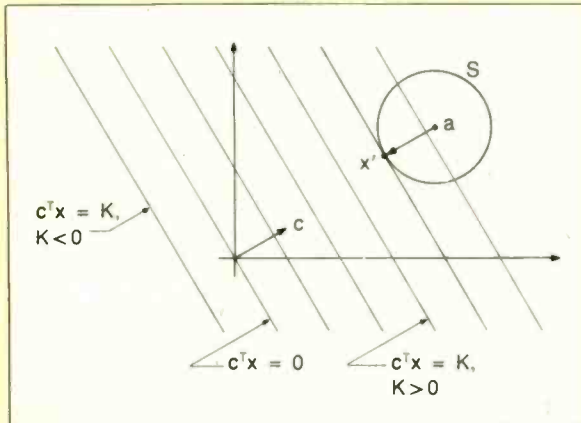

Figure A: Finding a point on the circle S that minimizes $c^T x$.

After we have investigated Karmarkar's solution of this problem, we shall show how to transform the general problem (3) into a problem of the form (4) and how to deal with assumptions (A) and (B). Assumption (C) is inherent in any calculation that uses finite-precision arithmetic.

To make our discussion less abstract, consider example 1 as an instance of problem (4):

Example 1:
$$\begin{aligned} &\text{minimize } (3 \ 3 \ -1)x \\ &\text{subject to } x \in \Omega \cap \Delta^2 \\ &\text{where } \Omega = \{x \mid (2 \ -3 \ 1)x = 0\} \text{ and} \\ &x \in R^3 \end{aligned}$$

We have sketched the region $\Omega \cap \Delta^2$ for this problem in figure 1. Since the objective function (the one being minimized) is linear and the region $\Omega \cap \Delta^2$ is a line segment, if the function is not constant on the region, then the minimum must occur at one endpoint or the other. At $(3/5, 2/5, 0)^T$ the value of the objective function is $(9/5 + 6/5 - 0) = 3$, while at $(0, 1/4, 3/4)^T$ the value is $(0 + 3/4 - 3/4) = 0$ and assumption (A) of problem (4) is satisfied. Since the center point $a_0 = (1/3, 1/3, 1/3)^T$ has $Ax = (2(1/3) - 3(1/3) + 1(1/3)) = 0$, it is a member of Ω , and assumption (B) is fulfilled.

We have a problem in which the region is bounded (by the simplex Δ^n), an interior point is known, the solution is known to be on the boundary, and an approximate solution will be satisfactory if it is within a preset tolerance of the desired value.

The Initial Step

Since a_0 of the simplex does not meet assumption (C), we cannot accept it as a solution to example 1. We must find a new point satisfying both assumptions (A) and (B) that gives a smaller objective function value. Karmarkar uses the objective function to find the best direction to move from a_0 as follows. Since $c \in R^{n+1}$ does not give a direction in the lower dimensional region $\Omega \cap \Delta^n$, c is projected orthogonally onto the region; this projected vector c^* then points in the direction opposite to the one we want (since we are minimizing, not maximizing). Since it suffices for the algorithm to move from interior point to interior point, Karmarkar further simplifies the problem by minimizing as follows: Inscribe a sphere in Δ^n centered at a_0 ; then the intersection of this sphere with Ω will again be a sphere of a lower dimension (because Ω is a subspace of R^{n+1} , and a_0 is both the center of the sphere and in Ω). But then this minimization problem is trivial (see the text box "Minimizing the Objective Function"), and we have found a point to which we should move. For technical reasons that provide a guaranteed minimum improvement (see "The Main Theorem" on page 150), Karmarkar does not move as far as possible on each step and effectively uses a smaller sphere than the inscribing one we have described.

In figure 2 we indicate this process as applied to example 1. Since both our example and drawing are contained in three dimensions, the final sphere in $\Omega \cap \Delta^2$ is of dimension 0 (two points), which makes the sketch rather trivial. However, this final sphere is two dimensions less than the simplex, and this is the case in general.

The General Iteration Step

If we call the initial point $x^{(0)}$ (so that $x^{(0)} = a_0$ and the result of the initial step is $x^{(1)}$), then we must describe the construction of $x^{(k+1)}$ from $x^{(k)}$ for $k > 0$. Each of these points is interior to $\Omega \cap \Delta^n$, and $x^{(k+1)}$ is obtained from $x^{(k)}$ in a manner similar to the initial step. Karmarkar applies a projective transformation from Δ^n to itself that moves $x^{(k)}$ to the center a_0 and fixes the corners of the simplex. But now the initial step method can be applied to find a better point in the transformed simplex, and

continued

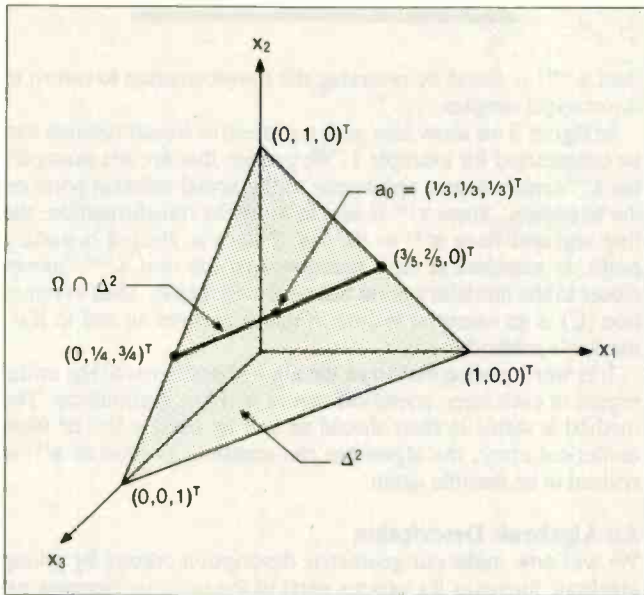

Figure 1: The region of example 1. The region $\Omega \cap \Delta^2$ is the intersection of the subspace of \mathbb{R}^3 and the two-dimensional simplex Δ^2 . In example 1, $\Omega = \{ \mathbf{x} \mid (2 - 3) \mathbf{x} = 0 \}$ is a plane passing through the origin and intersecting Δ^2 in the line segment from $(0, 1/4, 3/4)^T$ to $(3/5, 2/5, 0)^T$.

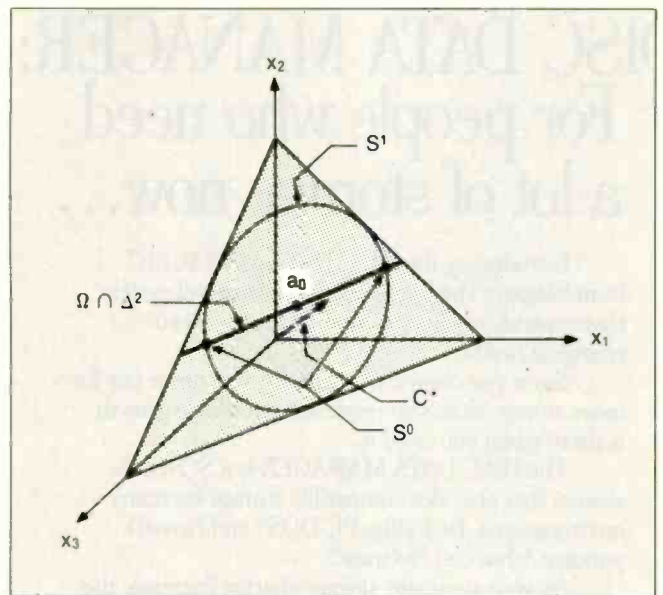

Figure 2: The initial step. The vector \mathbf{c}^* is obtained by an orthogonal projection of $(3, 3, -1)^T$ onto the region $\Omega \cap \Delta^2$; it goes behind the $x_1 - x_2$ plane. We show the inscribed one-dimensional sphere S^1 centered at \mathbf{a}_0 (the center of the circle). Its intersection with Ω is the lower dimensional sphere S^0 , also centered at \mathbf{a}_0 . Karmarkar's algorithm selects as the next point the point $\mathbf{x}^{(1)}$ part way toward the minimizing point on S^0 .

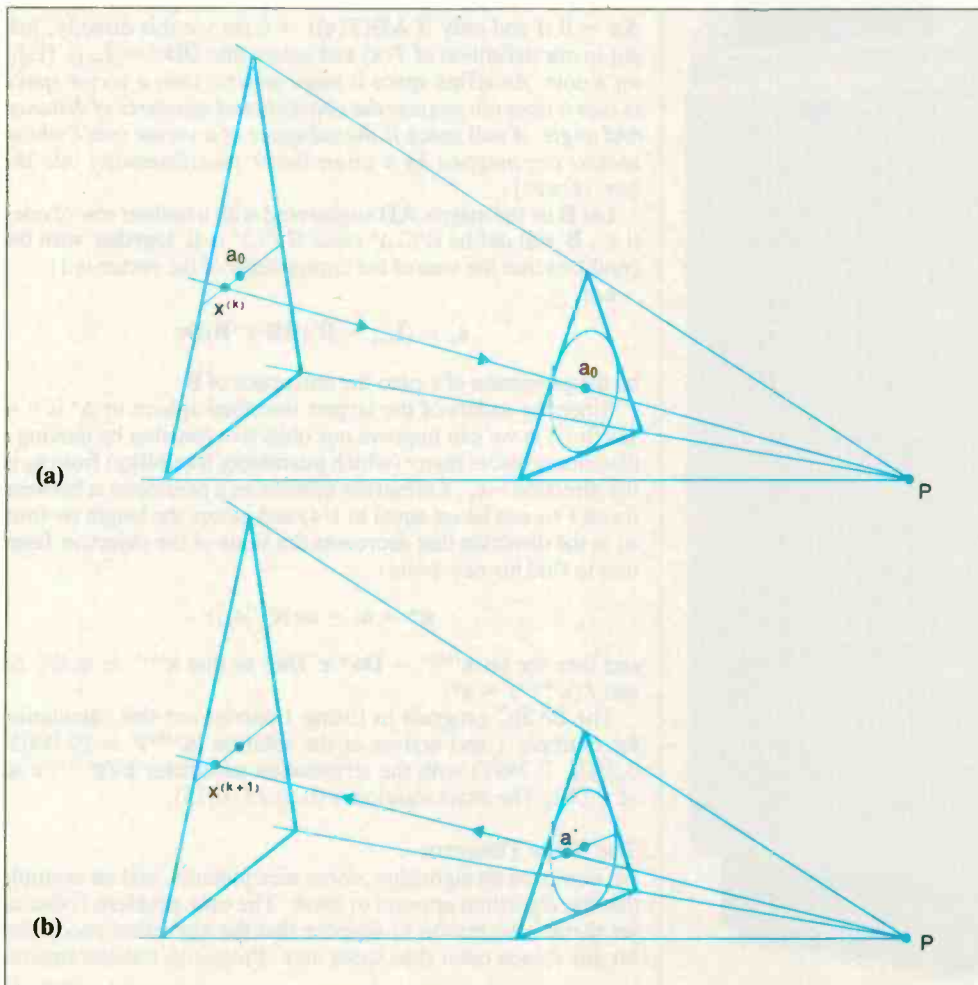

Figure 3: The general step: a projective transformation. To visualize a projective transformation from Δ^2 to itself, we imagine two separate simplexes of different sizes and orientations such that the lines joining the corresponding vertices all intersect at a common point \mathbf{P} and the image of $\mathbf{x}^{(k)}$ in the first (left) simplex is \mathbf{a}_0 in the second simplex (figure 3a). After optimizing in the second simplex, the solution points \mathbf{a}^* and \mathbf{P} determine a line that intersects the first simplex at $\mathbf{x}^{(k+1)}$ (figure 3b). Connoisseurs of projective geometry will recognize this sketch as one portion of the proof of Desargues's theorem.

DISC DATA MANAGER: For people who need a lot of storage now...

Introducing the DISC DATA MANAGER™ from Seagate. The high-capacity storage subsystem that expands module by module to meet your changing needs.

Since you choose the capacity, you never pay for more storage than you need. Yet, affordable growth is there when you need it.

The DISC DATA MANAGER is a SCSI subsystem that provides compatible storage for many environments. Including PC-DOS* and Novell's popular Advanced Netware.*

As your needs for storage sharing increase, the DISC DATA MANAGER can be converted into the LAN DATA MANAGER™, a high-performance, IBM*-compatible file server.

But this is just half the story.

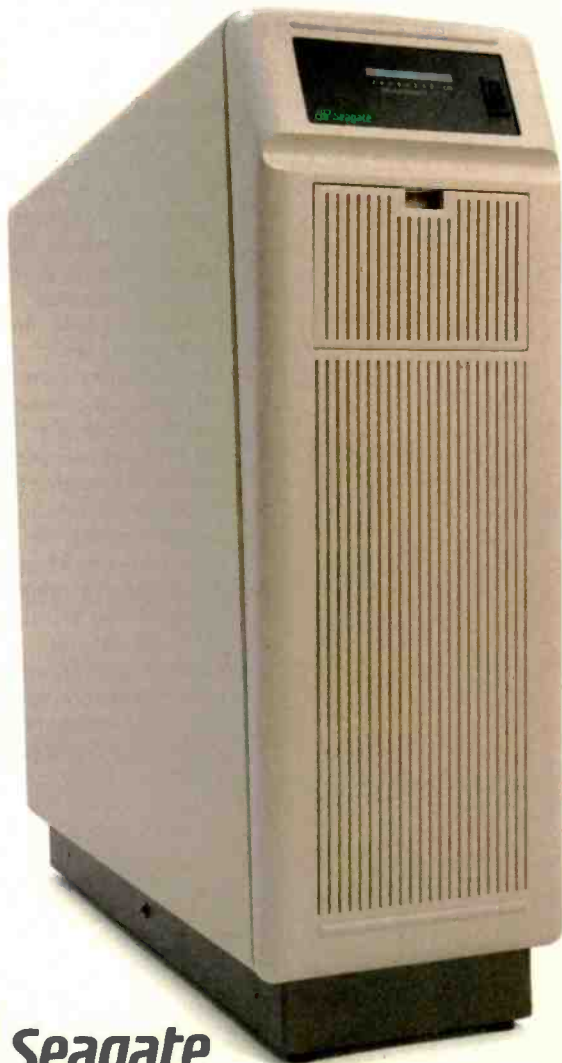

 **Seagate**

then $\mathbf{x}^{(k+1)}$ is found by reversing the transformation to return to the original simplex.

In figure 3 we show how such a projective transformation can be constructed for example 1. We can see that for this example, the $\mathbf{x}^{(k)}$ s move nearer and nearer to the actual solution point on the boundary. Since $\mathbf{x}^{(k)}$ is sent to \mathbf{a}_0 by the transformation, the line segment from $\mathbf{x}^{(k)}$ to $(0, 1/4, 3/4)$, the desired boundary point, is stretched at each iteration, and the next $\mathbf{x}^{(k+1)}$ moves closer to the boundary point but never reaches it. Thus assumption (C) is an essential feature in that it ensures an end to Karmarkar's method.

It is worth noting that since the algorithm returns to the initial region at each step, round-off errors will not accumulate. The method is stable in that, should an $\mathbf{x}^{(k)}$ be outside $\Omega \cap \Delta^n$ from numerical error, the algorithm can continue as soon as $\mathbf{x}^{(k)}$ is revised to be feasible again.

An Algebraic Description

We will now make our geometric description precise by giving algebraic formulas for various parts of the process. Suppose we have $\mathbf{x}^{(k)}$ and we want to find $\mathbf{x}^{(k+1)}$.

First we need a projective transformation $T: \Delta^n \rightarrow \Delta^n$, which sends $\mathbf{x}^{(k)}$ to \mathbf{a}_0 . Let $\mathbf{D} = \mathbf{D}(\mathbf{x}^{(k)})$ be the diagonal matrix of $\mathbf{x}^{(k)}$ and let $T(\mathbf{x})$ be $\mathbf{D}^{-1}\mathbf{x}/\mathbf{e}^T\mathbf{D}^{-1}\mathbf{x}$. Since $\mathbf{D}^{-1}\mathbf{x}^{(k)} = \mathbf{e}$ and $\mathbf{e}^T\mathbf{D}^{-1}\mathbf{x}^{(k)} = \mathbf{e}^T\mathbf{e} = n+1$, we see that $T(\mathbf{x}^{(k)}) = \mathbf{a}_0$. To show that T is a projective transformation, it suffices to show that T takes lines to lines.

Notice that $T(\mathbf{x})$ is really $\mathbf{D}^{-1}\mathbf{x}$ together with a normalization so that $T(\mathbf{x})$ remains in Δ^n . Since $\Omega = \{\mathbf{x} \mid \mathbf{A}\mathbf{x} = \mathbf{0}\}$ is an affine space and projective transformations preserve affine spaces, $\Omega' = T(\Omega)$ is an affine space. Ω' is also the null space of $\mathbf{A}\mathbf{D}$ since $\mathbf{A}\mathbf{x} = \mathbf{0}$ if and only if $\mathbf{A}\mathbf{D}(T(\mathbf{x})) = \mathbf{0}$ (to see this directly, just put in our definition of $T(\mathbf{x})$ and notice that $\mathbf{D}\mathbf{D}^{-1} = \mathbf{I}_{n+1}$). [Editor's note: An affine space is more general than a vector space in that it does not possess the conventional measures of distance and angle. A null space is the subspace of a vector space whose vectors are mapped by a given linear transformation into the zero vector.]

Let \mathbf{B} be the matrix $\mathbf{A}\mathbf{D}$ augmented with a bottom row of ones (i.e., \mathbf{B} will define $\Omega' \cap \Delta^n$ since $\Omega' \cap \Delta^n$ is Ω' together with the condition that the sum of the components of the vector is 1).

Let

$$\mathbf{c}_p = (\mathbf{I}_{n+1} - \mathbf{B}^T(\mathbf{B}\mathbf{B}^T)^{-1}\mathbf{B})\mathbf{D}\mathbf{c}$$

be the projection of \mathbf{c} onto the null space of \mathbf{B} .

Since the radius of the largest inscribed sphere in Δ^n is $r = 1/\sqrt{(n+1)n}$ we can improve our objective function by moving a distance no more than r (which guarantees feasibility) from \mathbf{a}_0 in the direction $-\mathbf{c}_p$. Karmarkar introduces a parameter α between 0 and 1 (α can be set equal to 1/4) and moves the length αr from \mathbf{a}_0 in the direction that decreases the value of the objective function to find his new point

$$\mathbf{a}^* = \mathbf{a}_0 - \alpha r (\mathbf{c}_p / |\mathbf{c}_p|)$$

and then we set $\mathbf{x}^{(k+1)} = \mathbf{D}\mathbf{a}^*/\mathbf{e}^T\mathbf{D}\mathbf{a}^*$ so that $\mathbf{x}^{(k+1)}$ is in $\Omega \cap \Delta^n$ and $T(\mathbf{x}^{(k+1)}) = \mathbf{a}^*$.

The BASIC program in listing 1 carries out this calculation for example 1 and arrives at the solution $(\mathbf{x}^{(19)})^T = (0.0003, 0.2501, 0.7497)$ with the termination parameter $\mathbf{c}^T(\mathbf{x}^{(19)})/\mathbf{c}^T\mathbf{a}_0 < 0.001$. The exact solution is $(0, 0.25, 0.75)$.

The Main Theorem

We now have an algorithm, some nice pictures, and an example that the algorithm appears to solve. The only problem is that as yet there is no reason to suppose that the algorithm succeeded for any reason other than sheer luck. Projective transformations

continued

Listing 1: This BASIC program, KAREX1, is written in a version of Microsoft BASIC that should run on most microcomputers. It solves the problem given as example 1 in the text.

```

200 '
202 ' N is number of unknowns and K is the
    number of equations
204 '
206 N = 3 : K = 1
208 '
210 K1 = K + 1 : K2 = 2*K1
212 DIM AO(N), XOLD(N), XNEW(N), CC(N), CP(N), A(K,N),
    B(K1,N), B1(K1,K2), B2(N,K1), B3(N,N)
214 '
216 ' CC is for the objective function
218 ' B1, B2 and B3 are used for the computation of CP
220 ' R and C are "row" and "column" indices
222 '
224 ' Initially, set XNew = AO, the center of simplex
226 '
228 FOR C = 1 TO N: AO(C) = 1 / N : XNEW(C) : AO(C)
    :NEXT C
230 '
232 ' T is the tolerance
234 '
236 T = .001
238 '
240 ' ALPHA is usually set equal to 1/4
242 '
244 ALPHA = .25
246 '
248 ITERATION = 0
250 '
252 ' Data for constraint matrix A
254 '
256 DATA 2, -3, 1
258 '
260 FOR R = 1 TO K: FOR C = 1 TO N: READ A(R,C):NEXT C:NEXT R
262 '
264 ' Data for objective function CC
266 '
268 DATA 3, 3, -1
270 '
272 FOR C = 1 TO N: READ CC(C): NEXT C
274 '
276 ' Set initial Value to value at center of simplex...
278 '
280 V = 0 : FOR C=1 TO N: V = V + CC(C)*AO(C):NEXT C: VNEW = V
282 '
284 ' Now we can begin the MAIN ITERATION process...
286 '
300 WHILE VNEW / V > T
301 '
302 PRINT USING "####"; ITERATION; :
    FOR C=1 TO N: PRINT USING
        "###.####"; XNEW(C); :
        NEXT C : PRINT USING
        "###.####"; VNEW / V
303 '
304 ITERATION = ITERATION + 1
305 '
306 ' Put Xnew into Xold
307 '
308 FOR C = 1 TO N : XOLD(C) = XNEW(C) : NEXT C
309 '
310 ' Construct the matrix B
311 '
312 FOR R=1 TO K: FOR C=1 TO N: B(R,C)=A(R,C)*XOLD(C):
    NEXT C:NEXT R

```

continued

...and a lot more in the future.

With the DISC DATA MANAGER, you can add more disc drives as your need for storage grows. Adding one or more drives gives you a capacity range from 160 MB to over 1 gigabyte.

Using multiple drives, you can perform overlapping operations. Or back up important files on separate drives. There's even an optional 40 MB tape drive for archival storage.

Best of all, the DISC DATA MANAGER is made by Seagate, the people who have built reliable performance into more than 6 million 5¼" hard disc drives.

For more information on the storage subsystem that grows with you, call us. 800-468-DISC. Ask for Tim.



DISC DATA MANAGER and LAN DATA MANAGER are trademarks of Seagate Technology. IBM and PC-DOS are registered trademarks of International Business Machines Corporation. Novell Advanced Netware is a trademark of Novell, Inc.

 **Seagate**

Inquiry 259 for End-Users.

Inquiry 260 for DEALERS ONLY. SEPTEMBER 1987 • BYTE 151

KARMAKAR'S ALGORITHM

```

313 FOR C = 1 TO N : B(K1,C) = 1 : NEXT C
314 '
315 ' Zero matrices to be used in computations...
316 '
317 FOR R=1 TO K1 : FOR C=1 TO K2 : B1(R,C)=0 NEXT C : NEXT R
318 FOR R=1 TO N : FOR C=1 TO K1 : B2(R,C)=0 NEXT C : NEXT R
319 FOR R=1 TO N : FOR C=1 TO N : B3(R,C)=0 : NEXT C : NEXT R
320 FOR C=1 TO N : CP(C) = 0 : NEXT C
321 '
322 ' Find BBT and put in B1
323 '
324 FOR R = 1 TO K1 :
  FOR C = 1 TO K1 :
    FOR I = 1 TO N: B1(R,C)=B1(R,C)+B(R,I)*B(C,I) : NEXT I :
  NEXT C :
NEXT R
325 '
326 ' Adjoin an identity matrix to BBT
327 '
328 FOR I = 1 TO K1 : B1(I,I+K1)=1 : NEXT I
329 '
330 ' Row reduce BBT|I
331 '
332 FOR R = 1 TO K1
333 IF B1(R,R) <> 0 THEN 338
335 I = <R + 1
335 IF I > K1 THEN PRINT "Error! BBT is SINGULAR!":
GOTO 400
336 IF B1(I,R) = 0 THEN I = I+1 : GOTO 335
337 FOR C = 1 TO K2 : SWAP B1(R,C), B1(I,C) : NEXT C
338 FOR I = R+1 TO K1 :
  Z = B1(I,R) / B1(R,R) :
  FOR C=1 TO K2: B1(I,C)=B1(I,C)-Z*B1(R,C) : NEXT C
NEXT I :
339 NEXT R
340 '
341 ' Now back substitute to finish it...
342 '
343 ' FOR R = K1 TO 2 STEP -1 :
  FOR I = R-1 TO 1 STEP -1 :
    Z = B1(I,R)/B1(R,R) :
    FOR C = R TO K2 :
      B1(I,C)=B1(I,C)-Z*B1(R,C) :
    NEXT C :
  NEXT I :
NEXT R
344 '
345 Remember to make diagonal entries 1s
346 '
347 FOR R=1 TO K1 :
  Z = B1(R,R) :
  FOR C = 1 TO K2 : B1(R,C) = B1(R,C) / Z :
NEXT C :
NEXT R
348 '
349 ' BBT Inverse is now in B1 in columns K1+1 to K2
350 '
351 ' Now multiply BBT Inverse by BT and put in B2
352 '
353 FOR R = 1 TO N :
  FOR C = 1 TO K1 :
    FOR J = 1 TO K1: B2(R,C)=B2(R,C)+B(J,R)*B1
      (J,C+K1) :

```

```

NEXT J :
NEXT C :
NEXT R
354 '
355 ' Take THAT and multiply by B and put in B3
356 '
357 FOR R = 1 TO N :
  FOR C = 1 TO N :
    FOR J = 1 TO K1: B3(R,C)+B2(R,J)*B(J,C) : NEXT J :
  NEXT C :
NEXT R
358 '
359 ' Find I-B3 by subtracting 1s on diagonal and
changing signs
361 '
362 FOR R = 1 TO N : B3(R,R) = B3(R,R) - 1 : NEXT R
363 FOR R=1 TO N: FOR C=1 TO N: B3(R,C) = -1*B3(R,C) : NEXT
C: NEXT R
364 '
365 ' Multiply by D
366 '
367 FOR R=1 TO N: FOR C=1 TO N: B3(R,C)=B3(R,C)*XOLD(C) :
NEXT C: NEXT R
368 '
369 ' Find projection of CC and call it CP
370 '
371 FOR R=1 TO N: FOR C=1 TO N: CP(R)=CP(R)+B3(R,C)*CC(C) :
NEXT C: NEXT R
372 '
373 ' Find length of CP and the normalized CP
374 '
375 AA = 0
376 FOR C=1 TO N : AA = AA + CP(C)*CP(C) : NEXT C
377 AA = SQR(AA) : FOR C=1 TO N : CP(C) = CP(C) / AA : NEXT C
378 '
379 ' Find a*, project back to get new X...
380 '
381 AA = SQR(N*(N-1)) / ALPHA
382 FOR C=1 TO N : XNEW(C) = (AO(C) - CP(C) / AA)*XOLD(C)
: NEXT C
383 '
384 ' And remember to divide by "size" of new X to
385 ' complete the projective transformation back to
386 ' the original simplex
387 AA = 0
388 FOR C=1 TO N : XNEW(C) = XNEW(C) : NEXT C
389 FOR C=1 TO N : XNEW(C) = XNEW(C) / AA : NEXT C
390 '
391 ' Find objective function Value at NEW point X
392 '
393 VNEW = 0
394 FOR C=1 TO N : VNEW = VNEW + CC(C)*XNEW(C) : NEXT C
395 '
396 WEND ' End of main iteration loop...
397 '
398 PRINT: PRINT "Tolerance reached:
  Vnew / Vinitial = "; VNEW / V: PRINT
399 PRINT USING "####"; ITERATION; :
  FOR C=1 TO N: PRINT USING "###.####";
    XNEW(C); : NEXT C : PRINT USING
    "###.####"; VNEW / V
400 END

```

do not preserve linear functions such as the objective function of the problem. Karmarkar's main result is the association of a "potential function" with the objective function, and then a proof that his algorithm reduces the potential function by a guaranteed amount with each iteration, and then a proof that the reduction of the potential function is equivalent to reduction of the

ratio $c^T x / c^T a_0$. While an exposition of these proofs is beyond the scope of this article, we shall state his principal result and show how the reduction in $c^T x / c^T a_0$ then follows.

Given the objective function of problem (4), let the corresponding potential function $f(x)$ be

continued

Improve Your Word Processor With Hercules.

Now your word processor can have full display and printing flexibility without slowing down. The secret is the exclusive Hercules graphics card mode called RamFont. Which isn't really graphics at all.

You see, graphics mode is slow. That's why most IBM compatible word processors run in fast, but limited text mode (they can only display 256 ASCII characters).

No Compromises with RamFont.

RamFont lets most popular word processors display italics, subscripts, superscripts, foreign languages, different font styles and symbols etc. at lightning speed.

Some choice. Slow down software by using graphics mode to display italics, subscripts, superscripts, large characters, different fonts, etc. Or forget all that in favor of speedy text mode.

Hercules solved the problem without compromise some time ago... almost 200,000 graphics cards ago to be specific. Because in addition to text mode and 720x348 graphics, we include RamFont. Today's standard for text-based programs. RamFont gives the flexibility of graphics at the speed of text by displaying 3072 software defined characters instead of ASCII's limited 256. Available in two versions for your PC: the Hercules Graphics Card Plus

(for monochrome TTL monitors) and the Hercules InColor Card (for "EGA-type" and multi-sync monitors).

Improve Today's Software.

RamFont runs Microsoft Word complete with its excellent on-screen display of attributes and fonts. But there's a difference. It's up to four times faster than the graphics mode in which it was written. Only Hercules cards let Lotus Manuscript display boldface,

italics, subscripts, superscripts, and many equations in text processing mode. And RamFont expands Broderbund ForComment's viewing area to a full 80x43.

Programs like Design Enterprise's Alexander use it to display symbols (musical notes and foreign languages) which, before RamFont, were possible only in the much slower graphics mode. Other programs including Nota Bene, Word-MARC, and Qalam all have optimized displays with RamFont.

In fact, every word processor can run better with Hercules. Independent add-on packages (TurboFonts, the Enhance Star series, etc.) let word processors like Word Perfect, Multimate, WordStar, and Displaywrite take advantage of the same sort of display and printing flexibility.

Improve The Software of Tomorrow.

WYSIWYG for underlining, italics, subscripts, font display, etc. is just the beginning. A whole new generation of word processors will use RamFont to mix a nearly infinite variety of fonts in different sizes on-screen at sizzling text speed. Which will make them look like, but run much faster than most of today's desktop publishers.

So, for better word processing, ask for Hercules with RamFont. It's the most compatible way to improve your writing.

Hercules InColor Card

(For multi-synchronous and enhanced color "EGA-type" monitors.)

Runs all Hercules monochrome software in 2 colors, most popular software in up to 16 colors selected from a palette of 64.

- Standard Text—All programs run in 2 or more colors.
- Hercules 720x348 graphics in up to 16 colors—15% higher than EGA.
- Hercules RamFont—3,072 software definable characters in 16 colors up to 12,288 in 2 colors.

For more information call Hercules toll-free at: 1-800-532-0600 Ext. 304. In Canada, 1-800-323-0601 Ext. 304.

Hercules

We run your software better.

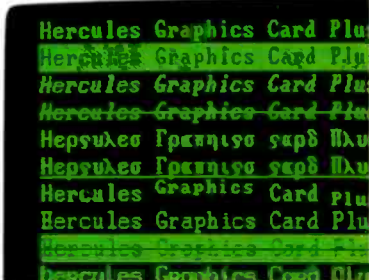

Tomorrow's software will display large and small characters in an almost infinite variety of styles at speeds heretofore impossible.



Hercules Graphics Card Plus

(For monochrome monitors)

Includes the three modes your software needs most:

- Standard Text—For thousands of text-based programs
- Hercules 720x348 graphics—highest popularly supported standard
- Hercules RamFont—3,072 software definable characters improve many popular software programs. (Call for the latest list.)



$$(5) \quad f(\mathbf{x}) = \sum_{i=1}^{n+1} \ln(\mathbf{c}^T \mathbf{x} / x_i)$$

where $\ln(r)$ is the natural logarithm of the real number r and x_i is the i th component of the $(n+1)$ -dimensional point \mathbf{x} . Karmarkar considers this potential function under the projective transformation T and shows that, in the transformed space $\Omega' \cap \Delta^n$, the point that minimizes $(\mathbf{Dc})^T(T(\mathbf{x}))$ on the inscribed sphere of radius αr either gives a value of zero or has reduced the transformed potential function by at least $\delta > 0$ where the constant δ depends on α . In particular, if $\alpha = 1/4$ then $\delta \geq 1/8$. Then applying the inverse transformation, he obtains

Karmarkar's theorem: Either (i) $\mathbf{c}^T \mathbf{x}^{(k+1)} = 0$ or (ii) $f(\mathbf{x}^{(k+1)}) \leq f(\mathbf{x}^{(k)}) - \delta$ where δ is a constant depending on α , and if $\alpha = 1/4$, then $\delta \geq 1/8$.

Suppose the algorithm has run for m iterations and $\mathbf{c}^T \mathbf{x}^{(m)} > 0$. How close to the solution have we come? Applying the theorem repeatedly, we have $f(\mathbf{x}^{(m)}) \leq f(\mathbf{x}^{(m-1)}) - \delta \leq \dots \leq f(\mathbf{x}^{(0)}) - m\delta$. Since $\mathbf{x}^0 = \mathbf{a}_0$, we have

$$\sum_{i=1}^{n+1} \ln(\mathbf{c}^T \mathbf{x}^{(m)} - \ln(x_i^{(m)})) \leq \sum_{i=1}^{n+1} \ln(\mathbf{c}^T \mathbf{a}_0 - \ln(1/(n+1))) - m\delta$$

so

$$(n+1)\ln(\mathbf{c}^T \mathbf{x}^{(m)}) - \sum_{i=1}^{n+1} \ln(x_i^{(m)}) \leq (n+1)(\ln(\mathbf{c}^T \mathbf{a}_0) + \ln(n+1)) - m\delta$$

which gives us

$$(6) \quad \ln\left(\frac{\mathbf{c}^T \mathbf{x}^{(m)}}{\mathbf{c}^T \mathbf{a}_0}\right) \leq \ln(n+1) + \frac{1}{n+1} \sum_{i=1}^{n+1} \ln(x_i^{(m)}) - \frac{m\delta}{n+1}$$

Because $\mathbf{x}^{(m)}$ is in the interior of Δ^n , all of the components of $\mathbf{x}^{(m)}$ are $0 < x_i^{(m)} < 1$ and so the term $\sum \ln(x_i^{(m)})$ is negative. Thus

$$\ln\left(\frac{\mathbf{c}^T \mathbf{x}^{(m)}}{\mathbf{c}^T \mathbf{a}_0}\right) < \ln(n+1) - \frac{m\delta}{(n+1)}$$

The equation

$$m = \frac{(n+1)(q + \ln(n+1))}{\delta}$$

gives us the number of iterations of Karmarkar's algorithm we need to calculate. To see that this is true, substitute m into the last inequality, which eventually becomes

$$\ln\left(\frac{\mathbf{c}^T \mathbf{x}^{(m)}}{\mathbf{c}^T \mathbf{a}_0}\right) < -q.$$

Exponentiating both sides and noting that $e^{-q} < 2^{-q}$ for $q < 0$, we get

$$\frac{\mathbf{c}^T \mathbf{x}^{(m)}}{\mathbf{c}^T \mathbf{a}_0} < e^{-q} < 2^{-q},$$

which is equivalent to condition (C) of Karmarkar's restricted problem, problem (4). The above definition for m leads us to approximate the number of iterations of Karmarkar's algorithm as $O((n+1)(q + \ln(n+1)))$.

Nonzero Objective Functions

We now turn to the assumptions we made about problem (4). Assumption (A) was that the minimum of the objective function

was zero. Let us now suppose that the minimum is not zero but some other number M . How can we regain assumption (A)? Since $\mathbf{x} \in \Delta^n$, $x_1 + \dots + x_{n+1} = 1$ and multiplication by M gives $M = M(x_1 + \dots + x_{n+1})$. Now we can make the objective function homogeneous by considering instead

$$\mathbf{c}^T \mathbf{x} - M\mathbf{x} = (\mathbf{c} - M\mathbf{e})^T \mathbf{x}$$

since the minimum of this function is zero.

As an example, let us alter example 1 by changing only the objective function:

Example 1a: minimize $(1 \ 1 \ 0)\mathbf{x}$
subject to $\mathbf{x} \in \Omega \cap \Delta^2$
where $\Omega = \{\mathbf{x} \mid (2 \ -3 \ 1)\mathbf{x} = 0\}$ and $\mathbf{x} \in R^3$

(This retains the region $\Omega \cap \Delta^2$ of example 1.) The minimum still occurs at $(0, 1/4, 3/4)^T$, but instead of 0 it is now $1/4$. The alteration discussed above gives the new objective function

$$(1 \ 1 \ 0)\mathbf{x} - (1/4)\mathbf{x} = (3/4 \ 3/4 \ -1/4)\mathbf{x}$$

which has a minimum value of 0.

Reduction to the Restricted Problem

Actually, example 1a came from a problem of the general form (3). Let us see how the reduction of problem type (3) to type (4) was carried out for the example problems before we consider the reduction method in general. Consider the problem

Example 1b: minimize $(1 \ 1)\mathbf{x}$
subject to $(2 \ -3)\mathbf{x} = -1$ (where $\mathbf{x} \in P_+^2$)

and the sketch of the constraint region in figure 4. Notice that the minimum occurs at $(0, 1/3)^T$ and that $(1, 1)^T$ is an interior feasible point. We construct a projective transformation T from P_+^2 to Δ^2 as follows:

$$\begin{aligned} X_1 &= x_1/(x_1 + x_2 + 1) \\ X_2 &= x_2/(x_1 + x_2 + 1) \\ X_3 &= 1/(x_1 + x_2 + 1) \end{aligned}$$

where lowercase x components are for the vector of P_+^2 while uppercase X components are for the vector in Δ^2 (which requires three components since $\Delta^2 \subset R^3$). This transformation sends $(0, 1/3)^T$ to $(0, 1/4, 3/4)^T$ and the feasible point $(1, 1)^T$ to $(1/3, 1/3, 1/3)^T = \mathbf{a}_0 \in \Delta^2$. Since X_3 approaches 0 as $x_1, x_2 \rightarrow \infty$, we see that $X_3 = 0$ corresponds to "infinitely large" values for x_1 and x_2 in the far reaches of P_+^2 . Thus T has taken the unbounded region P_+^2 and compressed it into the bounded simplex Δ^2 .

What happens to the straight line $(2 \ -3)\mathbf{x} = -1$? Since $x_1 + x_2 + 1 \geq 1$ for $\mathbf{x} \in P_+^2$, we can rewrite the original constraint $\mathbf{A}\mathbf{x} = \mathbf{b}$ as

$$\frac{2x_1 - 3x_2}{x_1 + x_2 + 1} = \frac{-1}{x_1 + x_2 + 1}$$

which is the same as $2X_1 - 3X_2 + X_3 = 0$. With this done, we have reduced example 1b (of type (3)) into a problem of type (4). (Notice that the image of the half-line region in P_+^2 is a line segment in Δ^2 as we would expect, since T is a projective transformation.)

The reduction described in the previous paragraph is generalizable easily. Suppose we have any problem of type (3) and an interior feasible point $\mathbf{a} \in P_+^n$ (so that $\mathbf{A}\mathbf{a} = \mathbf{b}$). Let $T: P_+^n \rightarrow \Delta^n \subset R^{n+1}$ be given by

continued

Better Spreadsheets, Fast With Hercules.

Like to know a secret shared by nearly 200,000 Hercules RamFont users? Your 1-2-3, Symphony, Framework or Multiplan* will run better on a Hercules Graphics Card Plus or Hercules InColor Card.

And we run them better in a number of ways.



Hercules RamFont lets spreadsheets like 1-2-3 display nearly twice the data with no loss in scrolling speed.

Display More Data.

First, you get more data on the screen without sacrificing your ability to scroll or move around the spreadsheet fast. Hercules' exclusive RamFont mode lets 1-2-3 and Symphony display nearly twice as much data (from 2,000 characters to about 3,400) expanding your view from 80 columns x 25 rows to a full 90x38. Microsoft Multiplan's display expands from 80x25 to 90x30 with the ability to toggle between the two. And Ashton-Tate's Framework goes from 80x25 to 90x43.

More data on screen without a loss of scrolling speed means you get a more functional spreadsheet. And you get it fast.

Crisp Graphics. Mono & Color.

Hercules 720x348 graphics is the highest popularly supported resolution available for IBM PCs/XTs/ATs, and a wealth of compatibles.

Our industry-standard 720x348 graphics mode and RamFont mode are now available for

both monochrome TTL monitors (Hercules Graphics Card Plus) and enhanced color "EGA type" and multi-sync monitors (Hercules InColor Card).

All of which means that built-in graphics on 1-2-3, Symphony, Framework II, SuperCalc 4, Javelin, Open Access, and Enable will be able to run in both mono and full color on either card. And so can add-on packages like Microsoft Chart, VP Graphics, and Stella Business Graphics.

Compatibility Plus.

Which brings us to yet another big benefit for spreadsheets and graphics. Hercules cards are completely compatible with each other.

Any monochrome standard text, Hercules graphics or Hercules RamFont compatible program (and there are thousands of them) will run in two to sixteen colors on the Hercules InColor Card without changing video drivers.

And that makes moving (or networking) between mono and color systems a breeze.

So, for better spreadsheets ask for Hercules with RamFont. We're the graphics cards you can count on.

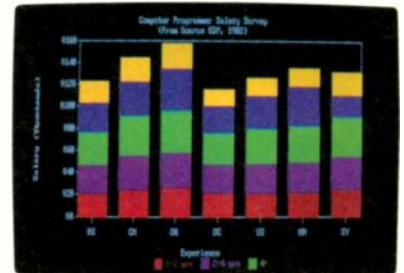

Hercules 720x348 resolution is now available in both mono and color for integrated or add-on graphics programs.



Hercules Graphics Card Plus

(For monochrome monitors)

Includes the three modes your software needs most:

- Standard Text—For thousands of text-based programs
- Hercules 720x348 graphics—highest popularly supported standard
- Hercules RamFont—3,072 software definable characters improve many popular software programs. (Call for the latest list.)

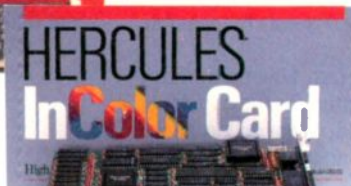

Hercules InColor Card

(For multi-sync and enhanced color "EGA-type" monitors.)

Runs all Hercules monochrome software in 2 colors, most popular software in up to 16 colors selected from a palette of 64.

- Standard Text—All programs run in 2 or more colors.
- Hercules 720x348 graphics in up to 16 colors—15% higher resolution than EGA.
- Hercules RamFont—3,072 software definable characters in 16 colors up to 12,288 in 2 colors.

For more information call Hercules toll-free at: 1-800-532-0600 Ext. 304. In Canada, 1-800-323-0601 Ext. 304.

Hercules

We run your software better.

Inquiry 118 for End-Users. Inquiry 119 for DEALERS ONLY.

Figure 4: Reduction to the restricted problem. The projective transformation T sending P_+^2 (the "first quadrant") to Δ^2 can be visualized as follows: Imagine tipping the sketch of P_+^2 so that "infinity" dips down to the horizon (a). What you now see is a triangle bounded by the two axes and the horizon line or "line at infinity" (b).

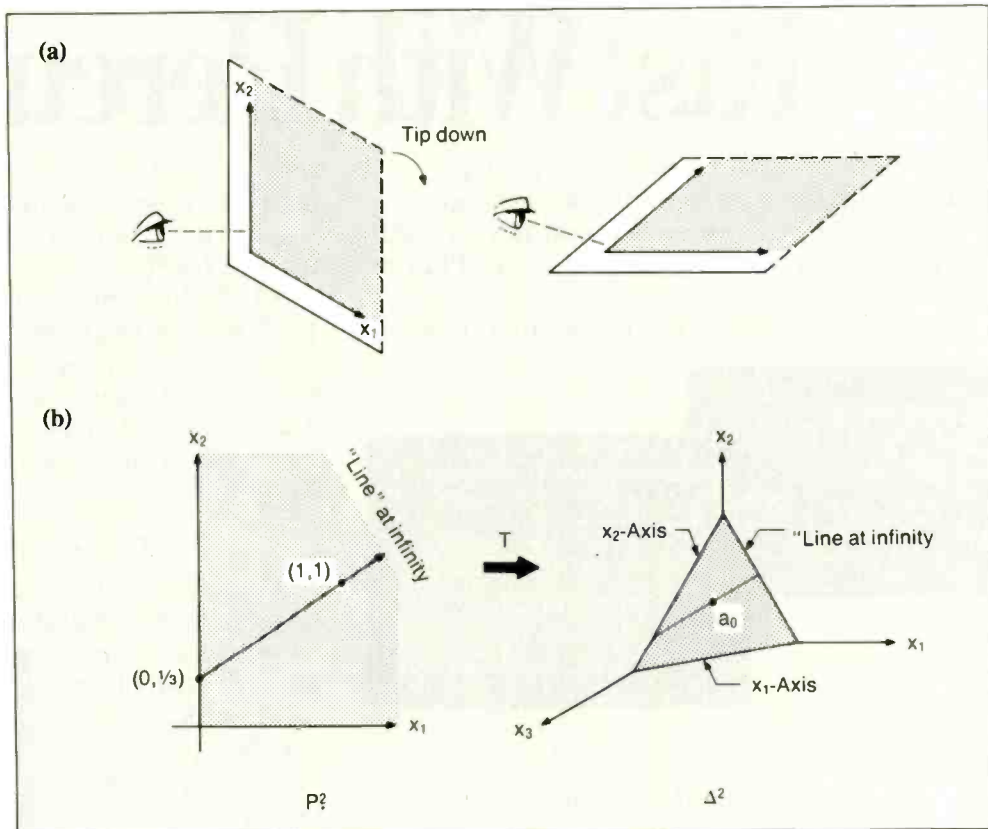

$$(7) \quad X_k = \frac{x_k/a_k}{(x_1/a_1) + \dots + (x_n/a_n) + 1} \quad \text{for } k = 1, \dots, n;$$

and

$$X_{n+1} = \frac{1}{(x_1/a_1) + \dots + (x_n/a_n) + 1}$$

where, as in the example, lowercase components are for the vector in P_+^n while uppercase components are for the vector in Δ^n (which requires $n+1$ components since $\Delta^n \subset R^{n+1}$). As in the example, the system of equations $\mathbf{Ax} = \mathbf{b}$ in problem (3) is transformed into a homogeneous system as required by problem (4) since we have the additional component X_{n+1} , which can be used to eliminate the constant terms in the constraints of (3). Moreover, assumption (B) is satisfied since T sends the feasible point \mathbf{a} to the center \mathbf{a}_0 of the simplex Δ^n .

It remains for us to explain two things: first, how the interior feasible point can be found (since it is essential for the construction of the transformation T); and second, what to do if the minimum of the objective function is not known.

Feasibility Problems

Given a system of equations $\mathbf{Ax} = \mathbf{b}$ as in problem (3), we wish to find a solution \mathbf{a} in the interior of P_+^n . Let $\mathbf{x}_0 = \mathbf{e}$ (so \mathbf{x}_0 is in the interior of P_+^n) and let $\mathbf{b}_0 = \mathbf{Ax}_0 - \mathbf{b}$. If $\mathbf{b}_0 = \mathbf{0}$, then \mathbf{x}_0 is feasible and we are done, so let us suppose that \mathbf{b}_0 is not zero. We introduce an artificial variable λ and consider the problem

$$(8) \quad \begin{aligned} &\text{minimize } \lambda \\ &\text{subject to } \mathbf{Ax} - \mathbf{b} = \lambda \mathbf{b}_0 \\ &\text{where } \mathbf{x} \geq 0 \text{ and } \lambda \geq 0 \end{aligned}$$

But $\mathbf{x} = \mathbf{x}_0$ and $\lambda = 1$ is a feasible point for (8), and this problem is of the form (3). If the minimum of λ is zero, then we have solved $\mathbf{Ax} - \mathbf{b} = \mathbf{0}$, and we have a feasible point for problem

(3). Of course, if there is no feasible point to be found, then problem (3) has no solution anyway.

Since the feasibility problem corresponding to example 1b is rather trivial, let us consider a slightly larger problem that might come from a problem of the form (1). The four inequalities

$$\begin{aligned} x_1 &\leq 3 \\ x_1 &\geq 2 \\ x_2 &\leq 5 \\ x_2 &\geq 4 \end{aligned}$$

form the boundaries of a 1-by-1 unit square in P_+^2 whose upper left corner is $(2, 5)^T$.

If we introduce four (nonnegative) slack variables, we can rewrite these inequalities as equalities:

$$\begin{aligned} x_1 &+ s_1 &= 3 \\ x_1 &- s_2 &= 2 \\ x_2 &+ s_3 &= 5 \\ x_2 &- s_4 &= 4 \end{aligned}$$

We now have a problem in P_+^6 . Setting $\mathbf{x}_0 = \mathbf{e}$ and $\mathbf{b}_0 = \mathbf{Ax}_0 - \mathbf{b}$, we find that $\mathbf{b}_0^T = (-1, -2, -3, -4)$, so our problem can be rewritten as

Example 2a:

$$\begin{aligned} &\text{minimize } (0000001)\mathbf{Y} \\ &\text{subject to } \begin{pmatrix} 1 & 0 & 1 & 0 & 0 & 0 & 1 \\ 1 & 0 & 0 & -1 & 0 & 0 & 2 \\ 0 & 1 & 0 & 0 & 1 & 0 & 3 \\ 0 & 1 & 0 & 0 & 0 & -1 & 4 \end{pmatrix} \mathbf{Y} = \begin{pmatrix} 3 \\ 2 \\ 5 \\ 4 \end{pmatrix} \end{aligned}$$

and $\mathbf{Y} \in P_+^7$

continued

De-clone Your Compatible With Hercules.

Most popular IBM PC/XT/AT compatible computers really stand out with Hercules Graphics Cards.

That's because our cards can actually improve the way software runs on the COMPAQ DeskPro 286/386, Leading Edge Model D, and IBM compatible models from Epson, Hewlett-Packard, Kaypro, NCR, Tandy, Zenith, and many others.

Three Modes You Need for Your Software.

Both the Hercules Graphics Card Plus (for TTL monochrome monitors) and new Hercules InColor Card (for multi-sync and enhanced color "EGA type" monitors) contain the three modes you need to get the most out of software on your compatible. **High Resolution Graphics:** Your PC benefits from Hercules' crisp 720x348 resolution—the highest popularly supported standard—in monochrome, or up to 16 colors.

RamFont Mode: This powerful new mode allows popular programs to display up to 3,072 software definable characters instead of the fixed 256 ASCII character set.

Text Mode: Thousands of standard text programs run on both Hercules cards.

With RamFont, Lotus 1-2-3 and Symphony display nearly twice their regular spreadsheet data... with no loss in scrolling speed. Microsoft Word runs up to four times faster. Lotus Manuscript, and many other word processors,

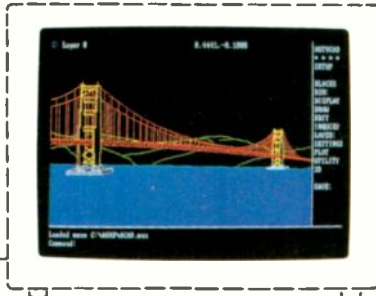

Hercules 720x348 resolution and RamFont are now available in up to 16 colors on your multi-sync or "EGA Type" monitor.

can have the true text speed display of italics, subscripts and superscripts. And, it enables add-on packages to open up whole new areas of font and foreign character display for programs like WordPerfect, WordStar, and Multimate; while providing powerful capabilities for software of the future.

We Love Compatibility

Our Graphics Card Plus and new InColor Card are completely compatible with each other. So you can

easily move your software from mono to color systems and back again without worrying about video drivers.

So to get the most out of your software, specify a Hercules Graphic Card Plus or a Hercules InColor Card for your system. And make your compatible more than a clone.



Hercules cards with RamFont let 1-2-3, and other popular spreadsheets, display nearly twice the data with no loss in scrolling speed.

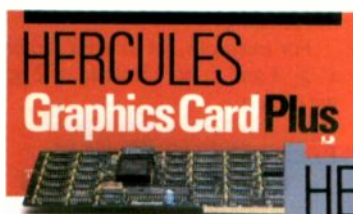

Hercules Graphics Card Plus

(For monochrome monitors)

Includes the three modes your software needs most:

- **Standard Text**—For thousands of text-based programs
- **Hercules 720x348 graphics**—highest popularly supported standard
- **Hercules RamFont**—3,072 software definable characters improve many popular software programs. (Call for the latest list.)

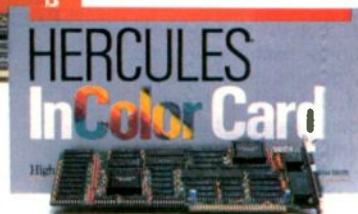

Hercules InColor Card

(For multi-sync and enhanced color "EGA-type" monitors.)

Runs all Hercules monochrome software in 2 colors, most popular software in up to 16 colors selected from a palette of 64.

- **Standard Text**—All programs run in 2 or more colors.
- **Hercules 720x348 graphics** in up to 16 colors—15% higher resolution than EGA.
- **Hercules RamFont**—3,072 software definable characters in 16 colors up to 12,288 in 2 colors.

For more information call Hercules toll-free at: 1-800-532-0600 Ext. 304. In Canada, 1-800-323-0601 Ext. 304.

Hercules

We run your software better.

Inquiry 120 for End-Users. Inquiry 121 for DEALERS ONLY.

New Quark®/PC Single Board Computer



Base model 5.75" x 8"

Only \$395.
Reg. Price ~~\$495~~
Quantity discounts available

- IBM PC® compatible single board computer mounts to 5 1/4" drive
- Includes Floppy Disk & Color Graphics CRT Controllers plus more

Also includes: Legal BIOS • Boots MSDOS® 3.0 • Printer Port • 2 Serial Ports • 256K RAM • Clock Speed at 4.77 MHz • Alphanumeric and Graphics Modes for Color Video Controller • Standard IBM® Keyboard Port.

Options include: 512K RAM • Piggyback I/O channel OEM Expansion Board • XT-Compatible Hard Disk SCSI Interface • Real Time Clock with battery-back-up • Clock speed of 9.5 MHz (twice as fast as a PC)

The Megatec Quark/PC is for OEM and end user applications that require PC compatibility in a compact single board computer. The Quark/PC BIOS will run most IBM PC® software including Flight Simulator and Lotus®. To meet your specifications a set of options let you add memory, speed and XT-compatible hard disk interface. Not only does it quickly mount to a 5 1/4" drive, it also comes with floppy disk and CRT color graphics controllers — all for just \$395.

To order or enquire call us today. Megatec Computer Corporation (416) 745-7214 150 Turbine Drive, Weston, Ontario M9L 2S2 U.S. Address: 1051 Clinton St., Buffalo, NY 14206
 Distributors: United Kingdom: Densitron (0959) 71011 (0959) 71015
 Italy: NCS Electronics (0331) 261-570
 Australia: Asp Microcomputers (02) 500-0628

Quark is a registered trademark of Megatec Computer Corp. IBM PC, IBM and PC DOS are registered trademarks of IBM Corp. Lotus is a registered trademark of Lotus Development Corp. MSDOS is a registered trademark of Microsoft Corp.

megatec

720K & 1.44MB
Drivers Available
For DOS 2.1 & Up!

NOW!
2MB Model
Available



THE 3.5" CONNECTION!

This internal 720K 3.5" disk drive is a "drop-in" replacement for 5.25" drives! It's the ideal solution for exchanging data between your PC/XT/AT and the new generation of laptops. Disk format is compatible with IBM, Toshiba and Zenith portables. The Model 853W drive kit contains everything you need, including interface adapters, premium SONY drive, and complete documentation. Uses your existing disk controller (no additional slots required). Requires DOS 3.2 for maximum performance. Ask about our Model 873W (1.44MB).

\$\$ SAVE \$\$
SONY DISKS



\$159.95
+ FRT. & TAX



2734-C Johnson Drive
P.O. Box 3717
Ventura, CA 93006



IMMEDIATE DELIVERY!

Call 805-658-7466 or 805-658-7467

KARMAKAR'S ALGORITHM

Here y_1, \dots, y_6 correspond to x_1, \dots, x_6 and y_7 to λ . But this problem is similar to example 1b, and we can apply the projective transformation $T: P^7 \rightarrow \Delta^7 \subset R^8$ given by

$$Y_k = \frac{y_k}{y_1 + \dots + y_7 + 1} \quad \text{for } k = 1, \dots, 7; \text{ and}$$

$$Y_8 = \frac{1}{y_1 + \dots + y_7 + 1}$$

(using our usual notation) to obtain a problem in the form of problem (4):

Example 2b:

minimize (0 0 0 0 0 1 0)Y

$$\text{subject to } \begin{pmatrix} 1 & 0 & 1 & 0 & 0 & 0 & 1 & -3 \\ 1 & 0 & 0 & -1 & 0 & 0 & 2 & -2 \\ 0 & 1 & 0 & 0 & 1 & 0 & 0 & -5 \\ 0 & 1 & 0 & 0 & 0 & -1 & 4 & -4 \end{pmatrix} Y = 0$$

and $Y \in \Delta^7$

After this problem is solved by Karmarkar's algorithm, the inverse projective transformation must be applied to return to our original coordinates in P^7 . Of course, we are interested only in the first two coordinates; the rest are the four slack variables and the artificial variable.

The BASIC program KAREX2 carries out this calculation for example 2 and arrives at the solution $x_1^{(26)} = 2.46123$ and $x_2^{(26)} = 4.42794$ with a tolerance of 0.001. [Editor's note: See the end of the article for more information on KAREX2 and KAREX3. These two programs are minor variations on listing 1.]

An Infeasible Problem

Suppose example 2 were not feasible. How would we have discovered this using Karmarkar's algorithm? From equation (6) we saw that if the algorithm is carried out m times, the ratio $c^T x^{(m)} / c^T a_0$ must be no more than a certain size. Thus given the q from assumption (C) of problem (4), we can calculate in advance the maximum number of iterations we will run the algorithm. If after that many iterations we do not have an answer within the required tolerance, then our system of equations is not feasible.

For example, let us alter the situation of example 2 to require $x_1 \geq 3$ and $x_1 \leq 2$ instead of $2 \leq x_1 \leq 3$. Proceeding as before, we obtain

Example 3:

minimize (0 0 0 0 0 1 0)Y

$$\text{subject to } \begin{pmatrix} 1 & 0 & -1 & 0 & 0 & 0 & 3 & -3 \\ 1 & 0 & 0 & 1 & 0 & 0 & 0 & -2 \\ 0 & 1 & 0 & 0 & 1 & 0 & 0 & -5 \\ 0 & 1 & 0 & 0 & 0 & -1 & 4 & -4 \end{pmatrix} Y = 0$$

and $Y \in \Delta^7$

The BASIC program KAREX3 attempts to solve this problem in the same manner that KAREX2 solved example 2, but we have added a "failure" detection routine: At the end of each iteration, the program tests inequality (6) and ends if it does not hold. We decided to use inequality (6) in our example rather than the later inequality Karmarkar used to estimate the number of iterations because dropping the $\sum \ln(x_k^{(m)})$ terms results in a rather large overestimate of the number of steps needed. The program fails at iteration 26 where $x_1^{(26)} = 1.81118$ and $x_2^{(26)} = 3.02786$.

continued

Finally! A printer as versatile as your PC.

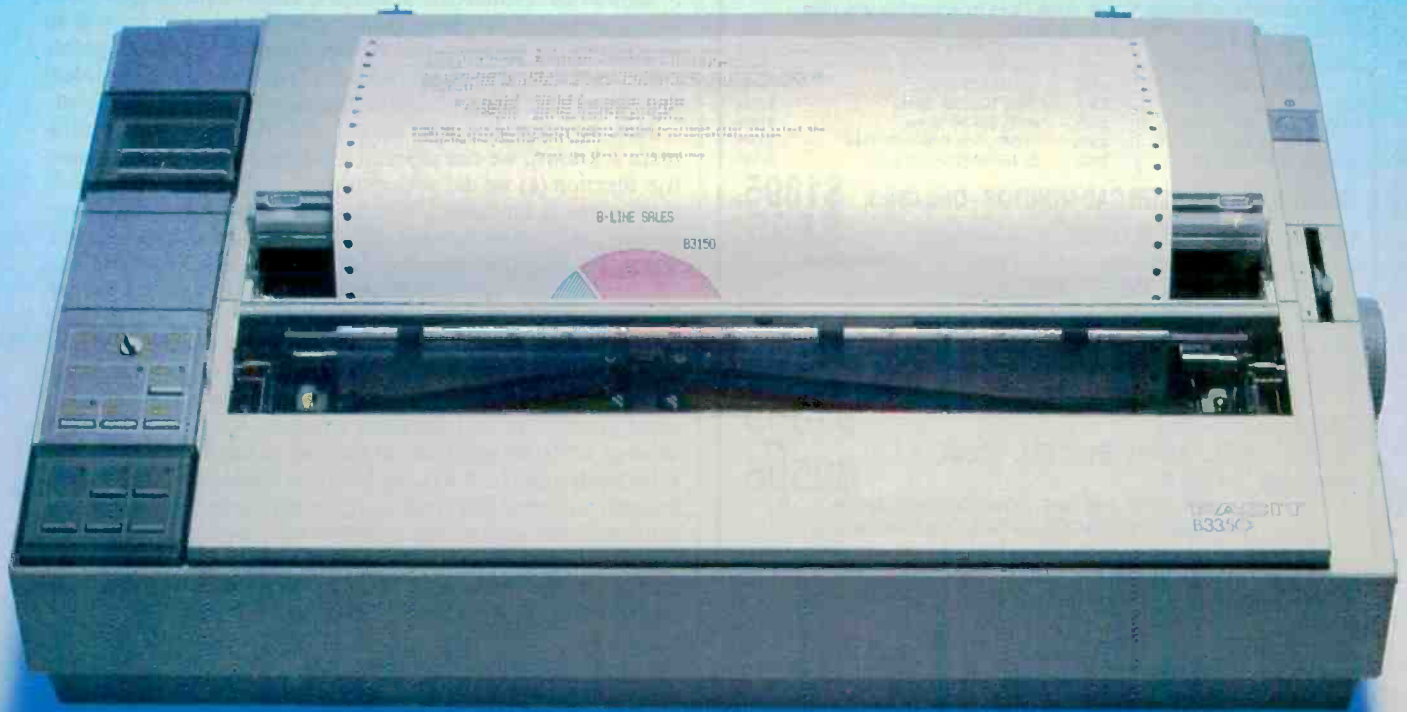

By giving you extraordinarily easy access to all the printout options your office needs, the new Facit B-line matrix printers really let you exploit the full potential of your PC.

Such as when you want to change from high throughput draft to perfect quality NLQ – just flick the rotary switch on the front panel. When you want to change font – just plug in a new font card. When you need to change from continuous forms to cut-sheets – the printer loads the paper for you.

And while the beauty of the B-line concept improves the impression made by your PC, the attractive design and low noise level make the printers perfect for every office environment, too.

FACIT

Inquiry 93

Head Office: Facit AB, S-172 91 Sundbyberg, Sweden. Phone: 468 764 30 00.
USA: Facit Inc. P.O. Box 334, Merrimack, NH 03054. Phone: (603) 424-8000

AUSTRALIA: EAI Electronics Associates Pty Ltd., 427-3322. AUSTRIA: Ericsson Information Systems GmbH, 0222-613 641. BELGIUM: Ericsson S.A., 02-243 82 11. CANADA: Facit Canada Inc., 416-825-8712. CYPRUS: LBM (Lillytos) Ltd 516 46 34. DENMARK: Facit A/S, 02-63 33 11. FINLAND: OY Facit, 90-420 21. FRANCE: Facit S.A., 1-4780 7117. GREAT BRITAIN: Facit 0634-40 20 80. GREECE: Computer Application Co. Ltd., 01-671 97 22. HONGKONG: Gilman & Co. Ltd., 5-893 00 22. ICELAND: Gisli J. Johnsen HF, J54-64 12 22. INDIA: Forbes Forbes Campbell & Co. Ltd., 22-20 48 081. IRELAND: Ericsson Information Systems Ltd., 75 30 93. ITALY: Facit Data Products S.p.A., 039-63 63 31. JAPAN: Electrolux (Japan) Ltd., 03-479-7570. KOREA: True Trading Co. Ltd., 2-783-3855-7. THE NETHERLANDS: Facit B.V., 3480-21784. NEW ZEELAND: Northrop Instruments and Systems, 501-801, 501-219. NORWAY: Ericsson Information Systems A/S, 02-35 58 20. PORTUGAL: Regisconta Sarl, 1-56 00 91. SINGAPORE: Far East Office Eqpts Pte Ltd., 745 82 88. SPAIN: Perifericos S.A., 4-57 90 81. SWEDEN: Ericsson Information Systems Sverige AB, 08-28 28 60. SWITZERLAND: Ericsson Information Systems AG, 01-821 59 21. USA: Facit Inc., (603) 424-8000. WEST GERMANY: Facit GmbH, 0211-61 090.

Check out the facts below and go for a test drive at your nearest Facit representative.

- B3100: 80 columns, 128 lines/minute* (250 cps)
 - B3150: 136 columns, 128 lines/minute* (250 cps)
 - B3350: 136 columns, 109 lines/minute* (200 cps), 18-needle printhead for 100 cps NLQ
 - Rotary switch for fast print quality selection
 - Easy operation with soft set-up in national language
 - Extensive paper handling – push/pull tractor, tear-off, automatic loading of single sheets. Optional single or double bin sheetfeeder
 - Low noise key
 - Facit, IBM Proprinter and Epson FX/JX emulations
 - Parallel and serial interfaces
 - 4-color option
 - Extra fonts by means of plug-in card
- * 80 col, 10 cpi.

IBM and Epson are reg. trademarks

COMPETITIVE EDGE SPEED SHOP SINCE 1980

1421 E. GOLDSMITH, PLYMOUTH, MI 48170
(313) 451-0665

16 MHz 386 BASE SYSTEM **\$3295.**

1024K, 40MB HD, 1.2 MB FLOPPY, FDC/HDC, 2 SERIAL, 1 PARALLEL PRINTER PORT, 8 SLOTS, MSDOS 3.1, KEYBOARD, COMPATIBLE WITH IBM AT(r).

20 MHz 386 SYSTEM **\$3795.**

1024K, 40 MB

12 MHz AT COMPATIBLE **\$849.**

640K ON MOTHERBOARD, CASE, POWER SUPPLY & KEYBOARD SETUP PROGRAM. OPTION A 1.2 MB FLOPPY & HD/FD CONTROLLER

HI-SPEED MONO CARD	\$ 99.	FLAT SCREEN AMBER MONITOR	\$300.
HI-SPEED EGA CARD	\$325.	EGA MONITOR 640 x 350	\$119.
NEC GB-1 EGA CARD	\$399.	NEC MULTI-SYNC	\$425.
20MB HD 65 ms	\$299.	72MB TOSHIBA 25 ms	\$549.
40MB ST25/40 ms	\$495.	80MB ST4096 28 ms	\$1095.
40MB HD 28 ms 6053	\$699.	112MB 25ms NEWBURY 1140	\$1095.
70MB HD 28 ms 6085	\$895.	231NB MAXTOR HD 28 ms	\$2295.
			\$2995.

19" MITSUBISHI, COLOR CAD MONITOR - ONE ONLY **\$1895.**

10MHz AT COMPATIBLE **\$695.**

640K ON MOTHERBOARD, CASE POWER SUPPLY & KEYBOARD, SETUP PROGRAM.

OPTION A 1.2 MB FLOPPY & HD/FD CONTROLLER	\$300.
OPTION B STD COLOR CARD	\$99.
CE EGA CARD	\$229.
STD COLOR MONITOR	\$309.
CE EGA MONITOR	\$425.

XT COMPATIBLE 20MB, MONO CARD & MONITOR 640K **\$1195.**

XT COMPATIBLE 20MB, STD COLOR CARD & CRT 640K **\$1369.**

12 MHZ BASIC XENIX SYSTEM, 1024K, 30MB HD, 3 USER **\$2595.**

INCLUDES XENIX RUN TIME, MONO CARD & MONITOR PRINTERS, SLAVES, NOVELL, XENIX, DOS AVAILABLE

AT IS A REGISTERED TRADEMARK OF INTERNATIONAL BUSINESS MACHINES XENIX IS A TRADEMARK OF MICROSOFT

KARMARKAR'S ALGORITHM

Solving an LP Problem

Now we can put all these pieces together and explain how to solve the linear programming problem (3). One way would be to rewrite the problem as a (giant) feasibility problem (as we described for Khachiyan's algorithm) and then proceed to solve it. While this way of solving a linear programming problem looks nice, it defeats the advantage of Karmarkar's approach: the use of the objective function as a gradient to find the "best" direction to move.

Karmarkar's solution is as follows: First, find a feasible point in the interior of P_* . If no point can be found, then there is no solution to the problem and we are finished. Given a feasible point, construct the transformation (7) and reduce the problem to the restricted form (4) with assumptions (B) and (C) fulfilled.

Now we must deal with assumption (A). If the actual minimum is known, we can proceed as before by altering the objective function (as we did with example 1a). But what if the minimum value is unknown? We can at least put upper and lower bounds, say u_0 and l_0 , on it (these may be ridiculous overestimates, but since the objective function is a linear function on a bounded region, such bounds must exist). Now divide the difference between these bounds into thirds and set $l_1 = l_0 + (u_0 - l_0)/3$ and $u_1 = u_0 - 2(u_0 - l_0)/3$. If we pretend that the minimum actually is l_1 and run the algorithm (modified so that it finds a point $x^{(m)}$ with $c^T x^{(m)} < 0$ then it backtracks along the line segment to $x^{(m-1)}$ to find the point with $c^T x = 0$ and returns this value as $x^{(m)}$, we will find out whether or not the real minimum is between l_0 and l_1 . If it is, we have new upper and lower bounds and we can repeat this process; if it is not, we can pretend that u_1 is the minimum and try again. Either way, the range between the upper and lower bounds is reduced by either 1/3 or 2/3 each time. In this way, we can zero in on the actual minimum of the objective function very quickly.

Some Implementation Comments

As you may have noticed, we have used $a_0 = e$, the unit vector, in our examples; this was done only to simplify the arithmetic. The projective transformation $T: P_* \rightarrow \Delta^n$ in equation (7) is defined for any point a in the interior of P_* ; clearly, the more "intelligent" your choice of a_0 , the quicker Karmarkar's algorithm will find the solution.

Karmarkar's estimates of the relation between the α and δ were crucial to the proofs of his theorems. Since the feasible point used as the initial point in his algorithm is arbitrary, it is clear that as a practical matter, α may be allowed to vary from step to step. One may choose α so that each successive approximation to the solution remains feasible and interior to Δ^n . You are invited to experiment with various α s in the example programs we have included.

While we have touched on the issue of complexity, our discussions have been far from complete. It is difficult to compare the simplex method and Karmarkar's algorithm since the work involved within each of their respective steps is different. The main bottleneck in Karmarkar's algorithm is the matrix inversion step needed for the orthogonal projection of c to c_p . In our sample programs, we have made no attempt at speed: We find $(BB^T)^{-1}$ by brute force row reduction of $BB^T | I_{m+1}$. Karmarkar also describes a modified algorithm in which the computations in the $(k+1)$ th step use those of the k th step, and he is able to reduce the arithmetic operations required for each step from $O(n^3)$ to $O(n^{2.5})$. Readers interested in this modification should consult Karmarkar's original paper (cited at the beginning of this article). ■

[Editor's note: The source code for KAREX1.BAS, KAREX2.BAS, and KAREX3.BAS is available on disk, in print, and on BIX. See the insert card following page 256 for details. Listings are also available on BYTEnet; see page 4.]

Customize Your Keyboard

- Eliminate Confusion
- Reduce Training Time
- Increase Productivity

Need Custom Keytops?
Call us at 602 634-7515

Hooleon
CORPORATION

P. O. Box 201, Dept. BY,
Cornville, AZ 86325

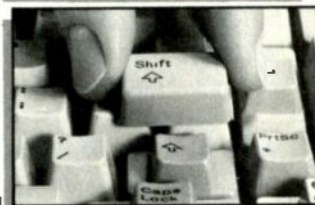

KEYTOPS—Kits to support most software, including:

___ PC to 5251	\$21.95	___ DisplayWrite 3	\$21.95
___ PC to 5520	\$29.95	___ WordPerfect 4.1	\$29.95

KEY EXPANDERS Touchdown™ key expanders enlarge small, critical keys (Return, Shift, Backspace, etc.) on the IBM PC and look-alikes to full-size, AT-style keys. Full kit has 12 separate expanders. Mini-Kit: Enter/Ret, both shifts, backspace. All kits support LED where needed. Must specify keyboard.

- Full Kit \$21.95
 Mini Kit \$10.95
 Black Gray

Language conversions available! Send me FREE INFORMATION

Specify Keyboard Make/Model: _____

Name: _____

Address: _____

City, St., Zip: _____

VISA MC # _____ Exp. _____

Visa or MC orders: 602 634-7515 Same Day Shipment • U.S. Postage Paid



Inquiry 125 for End-Users.

Printer Technologies

Color Printing	163
<i>by Naomi M. Luft</i>	
Vector-to-Raster Algorithms	177
<i>by Dick Pountain</i>	
Page Printers	187
<i>by Rick Cook</i>	
Print Quality	199
<i>by Lars Jansson</i>	
Engineering Close-Ups:	
Taming the Hot Heads	209
<i>by Keith B. Davenport</i>	
Matrix-Line Printing	215
<i>by Mark Hohneker</i>	
Color Thermal-Transfer Printing	221
<i>by Julio Guardado</i>	
Designing a High-Speed Page Printer Controller	225
<i>by Phil Ellison</i>	
Strip-Buffer vs. Full-Page Bit-Map Imaging	229
<i>by Bert Douglas</i>	



Introduction

Printer Technologies

The values by which we measure printers are easily understood and yet imprecisely defined. *Speed* is easiest to measure in characters per second, but that approach has little value to users, who are more interested in pages per minute, a value that can't be derived simply from a printer's maximum rate. But measures of throughput require agreement on what constitutes a representative document.

Quality doesn't lend itself to precise definition either. Each level of printing—draft, near-letter-quality, and letter-quality—has its own separate criteria. Furthermore, each different technology tends to have its own set of standards.

Even *cost* comparison is not always straightforward. Increasingly, printers have optional font cards or cartridges and software that may affect cost. With page printers, the addition of memory to a system may make cost comparisons misleading, and the presence or absence of on-board intelligence, in the form of a controller, can also confuse cost comparisons.

In this collection of articles, we've tried to help define the issues more precisely by explaining exactly what goes into the various technologies. Rick Cook's article, "Page Printers," brings out some important distinctions and limitations of laser, liquid-crystal-shutter, and light-emitting-diode designs. He explains why these units are so expensive and what it will take to bring their costs down.

In "Color Printing," Naomi M. Luft describes the subtractive color process and the various ways we have of currently getting living color on paper. This article also includes a text box entitled "Plastic Ink," which describes a new implementation of the ink-jet technology.

Lars Jansson takes an original and direct approach to the question of "Print Quality." He explains the factors affecting print quality and proposes a set of objective measurements. Dick Pountain puts aside his regular column this month to discuss the conversions necessary to make rasterized images from vector information in "Vector-to-Raster Algorithms."

Turning to more traditional printer designs, three short engineering close-ups give an insider's view of how dot-ma-

trix-impact, thermal-transfer, and other designs continue to be refined. "Taming the Hot Heads" by Keith B. Davenport shows how careful engineering and CAD have helped to maximize print-head efficiency and reduce the heat buildup that comes with fast printing. Mark Hohneker summarizes an alternative approach to standard dot-matrix-impact designs in "Matrix-Line Printing," and Julio Guardado describes another increasingly important technology in "Color Thermal-Transfer Printing."

Two additional engineering close-ups deal with page printers. In "Designing a High-Speed Page Printer Controller," Phil Ellison describes what is involved in making a page printer controller in order to maximize throughput. On an even more detailed level is Bert Douglas's article, "Strip-Buffer vs. Full-Page Bit-Map Imaging."

One aspect of printer technology we don't cover in this section is speed—how to measure and define it. Instead, we will conclude this introduction with a summary of a proposed new standard for measuring speed.

According to a draft version of the European Printer Performance Test (EPPT), 11 major printer manufacturers in Europe worked to develop the specification for measuring true print speed or throughput. The specification is intended for use with all printer designs (i.e., dot-matrix, daisy-wheel, ink-jet, thermal-transfer, and laser). The standard does not deal with measurements or criteria for measuring quality, character fonts, and so forth. However, it does provide a descriptive system for defining the various quality levels so that, for example, draft printing and letter-quality printing speed become objective terms.

The hope of the original group of 11 manufacturers is that the proposed standard will be adopted or at least incorporated into an official standard by the European Computer Manufacturers Association (ECMA) and the American National Standards Institute (ANSI). The test is designed for use only with printers that support European languages.

The tests are divided into performance tests and endurance tests. For the performance tests, the data patterns are printed five times. For the endurance tests, data patterns are printed repeatedly for 1 hour. The tests are (a) a letter test using a standardized letter; (b) a spreadsheet test using a 132-character-per-line spreadsheet; and (c) a graphics test, consisting of two vertical lines and two triangles, made up strictly of bit-image information.

The draft version of the EPPT runs 14 pages plus appendixes. It is a precise and well thought-out standard and, if adopted, will do much to eliminate the current confusion regarding advertising and specification of printing speed. For further information on the proposed EPPT, you can write to Alan Clemmetson, Dataquest U.K. Ltd., 13th Floor, Centre Point Bldg., 103 New Oxford St., London WC1A 1DD, U.K.

—George A. Stewart and Jane Morrill Tazelaar,
Technical Editors

Color Printing

A balancing act among price, performance, and print quality

Naomi M. Luft

IN COLOR PRINTING, you get what you pay for. The key word, and one I will use many times, is *trade-off*. You pay for higher resolution with longer processing and printing times. To get higher speed, you pay—and pay. To get more color choices, you trade effective print resolution. And the list goes on. But the list of available color-printing technologies also goes on; the current total is six.

In order of current popularity, these six basic color-printing technologies are pen and electrostatic plotters, and thermal-transfer, ink-jet, serial dot-matrix, and electrophotographic (color laser) printers. The vector-oriented pen plotters are by far the most popular, largely because they are flexible. They “write” with varied-color pens on various media and have a large base of existing software. However, raster-based competitive technologies are gaining ground by offering faster print speeds, superior text printing, and compatibility with the emerging world of digital imaging.

Unlike pen plotters, raster-based printing systems must perform several electronic image-creation functions, including combining basic colors under software control, precisely overlaying colors to get shades, and interpreting a rasterized bit stream rather than vector commands. Although each color-printing technology handles these required functions differently, some basic principles are common to all.

Generating Colors

The most familiar example of a raster-based product that produces a variety of

shades through color mixing is the television set. The color “model” used for producing colors on TVs, and the closely related color computer monitors, is RGB: Three light sources (red, green, and blue) generate the color within the monitor. The presence of all three colors creates white, while their absence results in black. Red, green, and blue are sometimes called the *additive* colors.

Printing systems usually do not use the RGB model because the colors are strong and opaque and therefore do not combine well. Instead, the complementary model, CMY (cyan, magenta, and yellow), is customary. Cyan, magenta, and yellow are referred to as the *subtractive* primaries because they create color by subtracting a particular color of light reflected off a white page. Cyan is the absence of red, magenta the absence of green, and yellow the absence of blue. You can combine these three colors to create the additive colors (red, green, and blue), as well as black (see figure 1). (Since this combined black often appears brown, many printers are also configured with a “true” black as a fourth color.)

The process of combining colors is mechanically tricky and represents a technical challenge for all printer technologies. With the exception of ink-jet, all color printers separate the printing function for each of the subtractive colors, overlaying the colors in several passes. Thus, registration is critical to ensure that each pixel lines up precisely with the corresponding pixel from a previous pass. In moving-head (serial) printing systems, such as serial dot-matrix and

some thermal-transfer printers, the print head traverses the same line repeatedly until it has printed all the colors, then the paper moves to the next line. Page-oriented systems, such as fixed-head thermal-transfer, electrostatic, and electrophotographic printers, print the entire page in one color before going to the next color.

Mixing Colors

Processing color separations and overlaying pixels become even more complex when an application requires more than the seven basic colors shown in figure 1. In general, printers lack the flexibility of computer monitors, which can vary shades under software control by varying the intensity of the electron beam. The only printing technology to achieve shading by varying the electrical signal is *dye sublimation*, an emerging subset of thermal-transfer printing that creates near-photographic-quality output. The more common approach to printing shades of the basic colors is *dithering*.

The dithering process generates shades of gray by mixing black with various percentages of white. Rather than treating each pixel as a single dot, systems that employ dithering combine dots into a matrix to create intermediate color values. Figure 2 shows how, in a 2-by-2 matrix,

continued

Naomi M. Luft is a senior research analyst specializing in nonimpact printing technology at Datek Information Services, P. O. Box 68, Newtonville, MA 02160.

you can combine the two basic values, black and white, into five shades.

In color systems, the range of shades increases substantially with a 2-by-2 matrix. Each subtractive color can have five intensity levels that can in turn be overprinted, thereby generating up to 125 different shades (5 by 5 by 5, with the three multiples representing the three subtractive colors). The possibilities increase as the matrix size increases. In a 3-by-3 matrix, each color can have 10 intensity levels, so you can achieve 1000 shades of

color. Dithering patterns exist in the application software, the printer-resident firmware, or a combination of both.

You make trade-offs, however, in this method of increasing the number of colors. Dithering is effective only in relatively high resolution systems in which individual dots are barely distinguishable and, consequently, a matrix of dots is small enough to appear as a single picture element, so the color shade appears spatially integrated to the eye. The matrix structure effectively reduces the printer's

resolution. For example, if a 200-dot-per-inch printer generates 125 shades using a 2-by-2 matrix, its effective resolution is reduced by that factor of 2 to 100 dpi. For 1000 colors (the 3-by-3 matrix), the effective resolution is reduced by a factor of 3 to 67 dpi. Therefore, when you need the highest possible resolution, you need to restrict your choices to the seven basic colors. Dithering is especially useful for shading large areas like pie charts in business graphics.

Two alternatives to dithering maintain printer resolution while they expand the number of color shades. One approach, used in commercial printing, is to vary the size of the dot in a technique called *halftoning*. Because it is difficult to control dot size with existing printer technologies, only a few specialized systems have taken this approach; most of them use ink-jet technology.

Another approach is to use ink or ribbons with more than three subtractive colors, ideally, two intensity levels for each subtractive primary. With six colors plus black, you could generate 216 colors per picture element without losing any resolution. The disadvantages of this approach are that the costs of hardware and supplies increase while throughput rates decline, since you need to either make more passes or distribute hardware resources, such as ink-jet nozzles, between more colors.

Setting Up Your System

With the exception of pen plotters, all current color printers are raster-based; that is, the image is decomposed into scan lines and then reconstructed during printing. Since most software defines graphics in terms of vectors, graphics systems have an algorithm to convert vector commands into a matrix for display on the raster-based monitor; you can use this same matrix to print the image (see "Vector-to-Raster Algorithms" by Dick Pountain on page 177). Again, trade-offs are involved in choosing various print matrices.

Three basic configuration choices exist: You can attach a printer directly to the monitor's screen buffer, which holds a bit map of pixel information; a printer can share the video signal with the monitor; or you can convert the computer's vector information into a printer-compatible raster image via software or dedicated hardware.

The first two choices are "screen-dump" methods that let you bypass the need for software drivers and generate quick hard copies of screen information. The information is transferred one for one from the computer to the hard-copy device; therefore, whatever is on the

continued

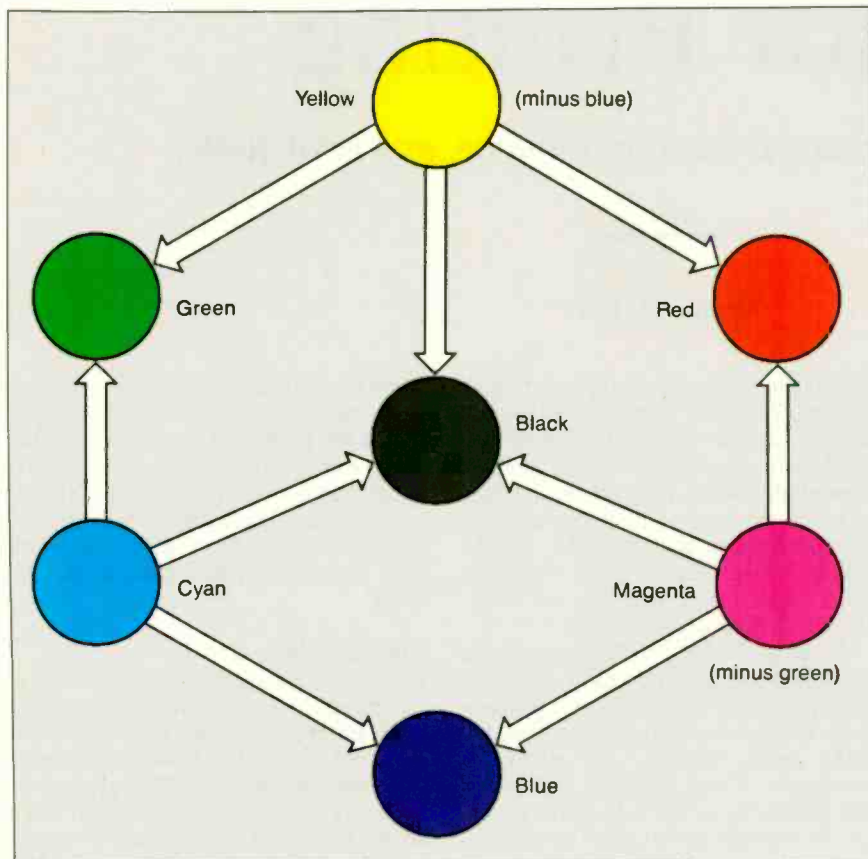

Figure 1: This diagram shows the actual subtractive colors: cyan, magenta, and yellow. The other colors—red, blue, green, and black—were formed by combining these colors; that is, the yellow and magenta together form the red shown here, and so on. The brownish black is a combination of CMY and illustrates why many printer manufacturers add a true black to their colors.

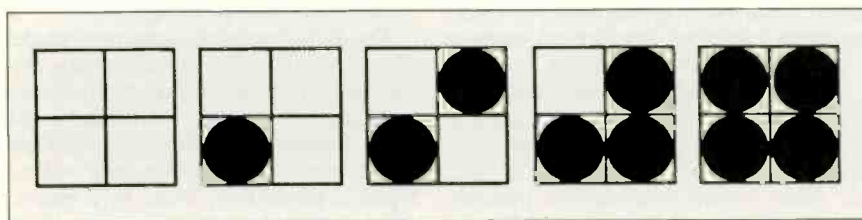

Figure 2: Dithering generates shades of gray by mixing black and white. Treating each dot as a 2-by-2 matrix lets you combine black and white into five shades: 100 percent white, 25 percent black and 75 percent white, 50/50, and so on. You can employ a similar scheme with colors, greatly increasing the number of available colors but also decreasing the final resolution.

Now Available!

FIVE NEW MODELS

SHARE PRINTERS AND BUFFER PRINT JOBS WITH ONE VERSATILE UNIT

Print Master from BayTech is an intelligent printer controller that connects between your computers and printers. It allows you to share one printer automatically, contend for multiple printers automatically, or switch between several printers by sending a simple code, not by changing cables. Plus, Print Master's generous built-in buffer spools data until your printers can receive it.

Because Print Master is a very flexible device, you can set it up to fit your application, even if your application changes.

YOU SET UP THE IN-OUT PORTS

You configure Print Master's ports for any combination of printers and computers by answering questions from easy-to-follow menus. For example, with the ten port Print Master, nine computers can share one printer, eight computers can share two printers, seven computers can share three printers, and so on, to one computer which can share nine printers. You can also menu-select the disconnect time-out, form feeds, etc. and on serial models, the configuration of individual ports to translate for printers and computers using different configurations.

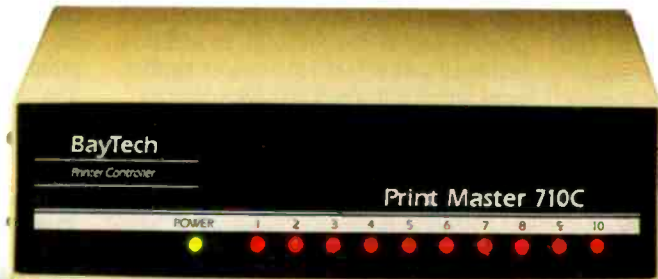

512K OR ONE MEGABYTE BUFFER KEEPS YOU WORKING INSTEAD OF WAITING

Since Print Master can accept data faster than your printer (up to 19.2KB serial or 5,000 characters per second parallel), you can send a print job to Print Master's standard 512K buffer and then go on to another project. All users connected to Print Master can send data to this common pool buffer, and they can be doing it simultaneously, even if no printer is available. Data is stored in the buffer until it can

be sent on a first-job-in first-job-out basis to the selected printer. If you need more memory than 512K, Print Master is optionally available with one megabyte buffer.

If several users are sharing one printer, printer sharing via Print Master is completely automatic. There are no codes to send. You simply perform your normal print operation. If you are sharing several identical printers, connection is also

automatic. Again, you perform your normal print operation and are connected to the next available printer on a first-come-first-serve basis. Print Master will send data to all printers simultaneously to keep your printers running at full capacity.

If you are sharing several different printers, such as a laser-jet, a dot matrix and a plotter, and you wish to select a specific printer, you do your normal print routine and also send a printer select code (which you can define yourself) before the first characters of your data. The data is then routed to the selected printer. It's that easy.

PARALLEL, RS-232C OR RS-422A MODELS

706A (6 parallel ports), \$795
706C (6 serial ports), \$795
708C (8 serial ports), \$895
710C (10 serial ports), \$995
706D (4 parallel/2 serial), \$795
708D (6 parallel/2 serial), \$895
706E (4 serial/2 parallel), \$795
708E (6 serial/2 parallel), \$895
710E (8 serial/2 parallel), \$995
708F (4 serial/4 parallel), \$895
710F (6 serial/4 parallel), \$995
All above models have standard 512K buffers.

Additional 500K buffer, \$249
RS422A for distances up to 4,000 feet now available on some models.

WANT DETAILS?

Call or write BayTech at P.O. Box 387, Highway 603, Bay Saint Louis, Mississippi 39520, USA. Telex 910-333-1618. Phone 601-467-8231 or

800-523-2702

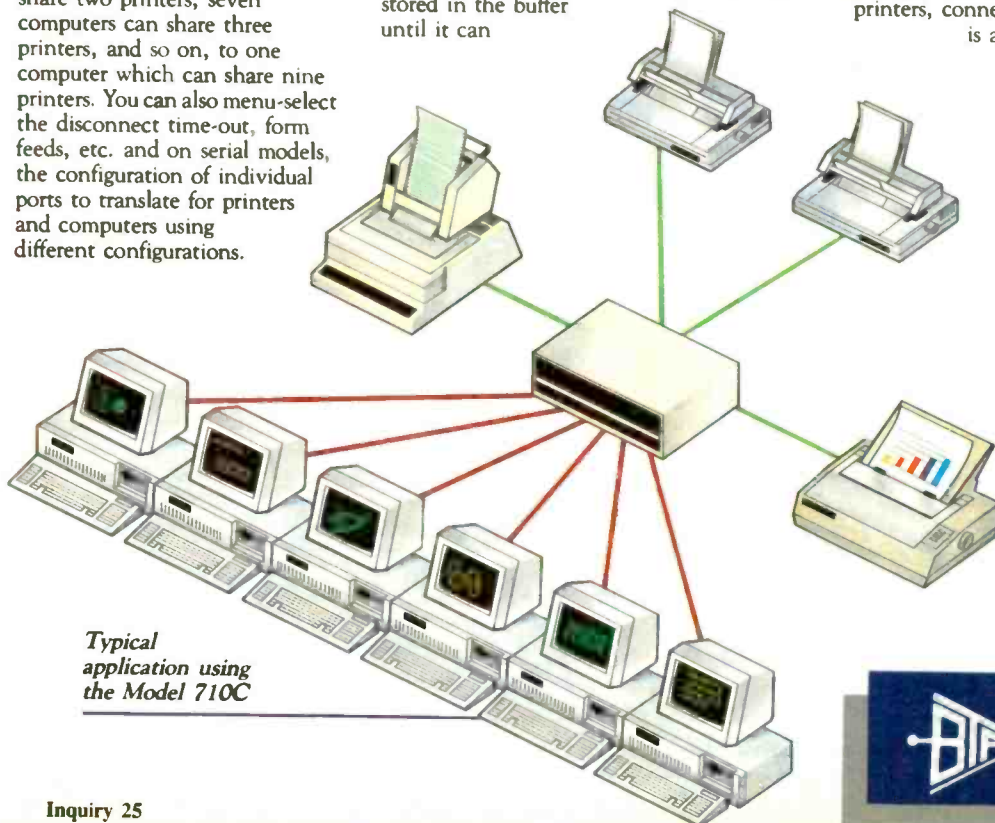

Typical application using the Model 710C



screen will appear exactly the same way on the printer. However, the printer usually has a higher resolution than the system monitor. Thus, when you transmit the pixels to the printer and print them at full resolution, the printed image becomes much smaller than the displayed image was. For example, a 640- by 480-pixel image on the screen printed at 200 dpi becomes a 3.2- by 2.4-inch printout. Systems usually compensate by assigning multiple print dots to each screen pixel to get a larger image. Since this method doesn't take advantage of the printer's higher resolution, the "jaggies" (visible stairstepping) from the screen also appear on the printout.

The third approach, converting vectors to raster information specifically for the printer, has the advantage of not limiting the image to the size of the monitor's screen buffer; printing can take place at full resolution. The trade-offs are in price and performance. Because the system must manipulate many more bits of information, this approach is both processing- and memory-intensive, which adds to the expense and can result in low throughput rates.

Vector-to-raster conversion can take two approaches: software- or hardware-based. Some systems generate raster data in host software and transmit a bit map to the printer via the standard printer interface. The main disadvantage of this software-based method is that it ties up the host during image processing. More advanced systems frequently use dedicated

hardware processors that are optimized for this conversion function. The configuration possibilities include an external box, an add-in card, and a printer-resident controller. Add-in cards can cost as little as \$600, while the higher-performance rasterizers can run over \$6000, a hefty price now that most high-end color printers cost under \$10,000. In addition, you need software drivers to link applications with each specific output device.

I want to look at the operating principles and performance trade-offs of the six color-printing and -plotting technologies currently available. Figure 3 illustrates how these technologies compare in price and performance.

Pen Plotters

To date, pen plotters have been the most popular color-output devices. Widely used in technical applications such as CAD/CAE, they can produce output up to E-size (34 by 44 inches). Office applications, such as business graphics and presentation materials, increasingly use plotters. Desktop models for A- and B-size drawings are available for under \$2000, and software drivers in numerous packages support them. On the systems level, pen plotters are less complex and less expensive than many other printers because they can interpret software directly in terms of vectors and, thus, don't need vector-to-raster conversion.

Mechanically intensive devices, pen plotters require that various pens and output media (paper, transparencies, vel-

lum) move under software control, so that the pens can actually write to generate a graphic and associated text. Plotting involves combining *x* and *y* motions to execute vector commands (e.g., to draw a line between two points or a circle around a point). You change colors by mechanically switching pens typically held in a carousel or bank along the side of the plotter. The number of pens ranges from 2 to more than 10.

Plotters fall into three basic groups: flatbed, drum, and hybrid. All three have a carriage bar along which the pen moves to draw along one axis (say, the *x* axis). They differ in how they achieve pen motion in the *y* direction. *Flatbed* plotters hold the paper stationary while the pen moves in the *y* direction; the size of the flatbed creates the limit on output size. For applications that require output-size flexibility, you would use a drum or hybrid model. *Drum* plotters move the paper back and forth using a rotation drum to achieve motion in the *y* direction. *Hybrid* plotters similarly move the paper to achieve *y* movement; however, they hold it between friction rollers, are much smaller than drum plotters, and have no mechanism for rolling up long plots.

Available pen plotters offer varying levels of plotting accuracy and speed. High-level systems have resolutions to 0.001 inch, meaning that they can mechanically place dots that close to each other. Another measure of accuracy is repeatability, or how precisely the plotter

continued

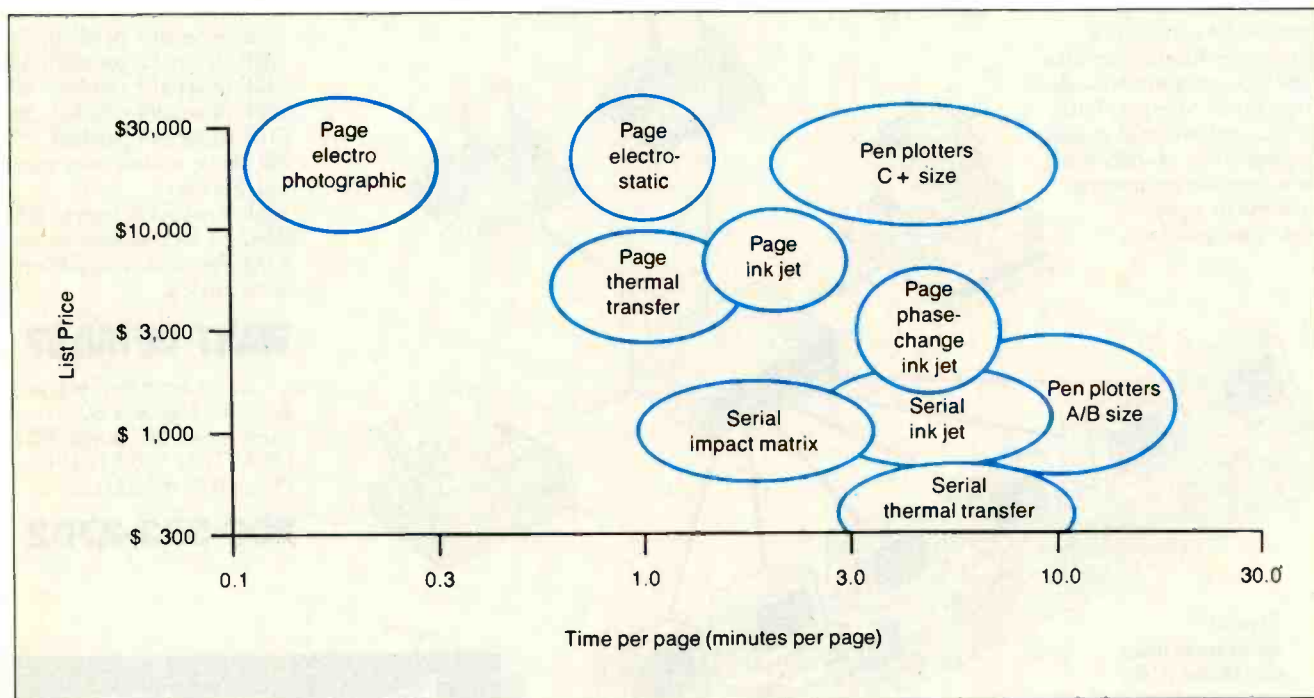

Figure 3: A price/performance comparison of color-printer technologies.



NOW DINERS CLUB CAN MAKE YOUR AMERICAN, CONTINENTAL, NORTHWEST AND UNITED FREQUENT FLYER MILEAGE REALLY SOAR.

From now on, when you use the Diners Club Card, you can earn Club RewardsSM points good towards exciting gifts and services. Including extra mileage in the participating frequent flyer program of your choice. Or, if you choose, frequent stayer credit at Hilton, Radisson, Ramada or Sheraton hotels.

So dine with the Diners Club Card. Sleep on it. Rent with it. Whatever. And watch your frequent flyer miles soar. Or use someone else's card...and miss all the rewards only Diners Club can give you.

Call 1-800-DINERS-1.

Join the Club. The rewards are endless.



Frequent Traveler benefits available through the Club RewardsSM program. Participating companies subject to change. Club Rewards is a service available only to Personal Cardmembers of Diners Club from Citicorp located within the 50 United States. Free enrollment required. Certain terms and conditions apply. *United participation limited to 1986-87 Club Rewards brochure.

can return to a specific point again and again. Although the pens can move several inches per second, effectively, pen plotters are the slowest color technology. Desktop-size plotters can take 3 to 6 minutes for simple business graphs and up to 20 minutes for more complex plots with large area fills.

Electrostatic Plotters

Electrostatic technology was the first raster-based output method widely used for printing color graphics, particularly in technical environments. Its primary advantages over pen plotting are its improved speed, quiet operation, and suitability for unattended operation. Like pen plotters, some electrostatic plotters are capable of large-format output. However,

electrostatic plotters are among the most expensive color printers available, with B-size products costing between \$12,000 and \$14,000, and larger-format plotters ranging from \$40,000 to \$100,000 or more. In addition, you must use a special dielectric coated paper.

Electrostatic plotters operate by passing dielectric paper under a fixed-page-width electrostatic head that consists of a line of individual styli. Voltage is selectively applied to the individual styli, placing a charge on the dielectric paper and creating a latent image. Then the paper passes through a bath of liquid toner, and the charged areas attract toner particles. In a color system, this charging and toning process takes place several times (three if you use CMY, four if you add a

separate black); the toner bath is different for each color. As a result, this technology is mechanically complex. Figure 4 is a schematic of an electrostatic plotter by Benson Inc.; this plotter is unique in that it has multiple heads as well as multiple toner baths so you don't need to rewind the paper between colors.

One advantage of electrostatic plotters is their high-resolution output. Several systems exist with 400-dpi resolution, which improves output quality, especially when you need a large number of colors (due to the trade-offs between dithering and resolution). Some plotters also have a lower-resolution mode for proofing or plotting at higher speeds; 400 dpi is relatively slow in terms of processing time and paper-indexing rate.

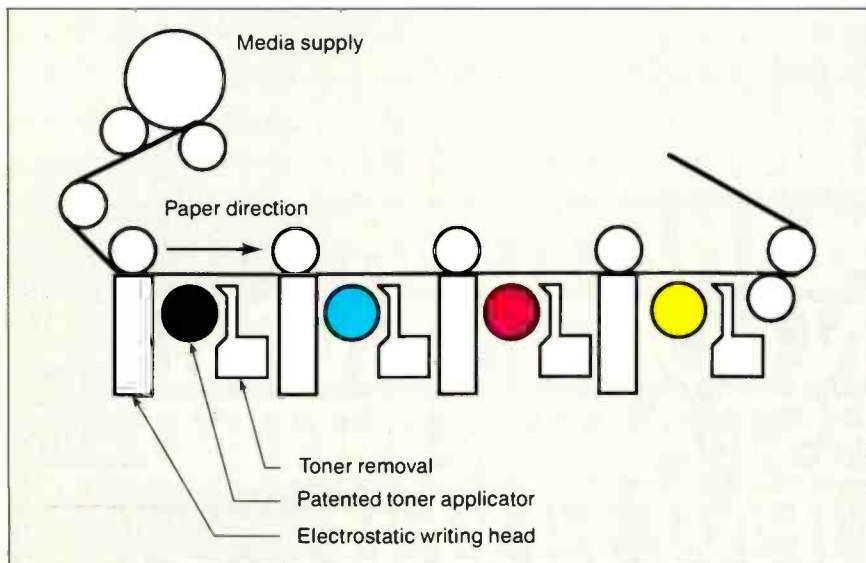

Figure 4: Schematic of an electrostatic plotter by Benson Inc. Note that this plotter has multiple electrostatic heads as well as multiple toner baths so that the paper makes only a single pass and needs no rewinding between colors.

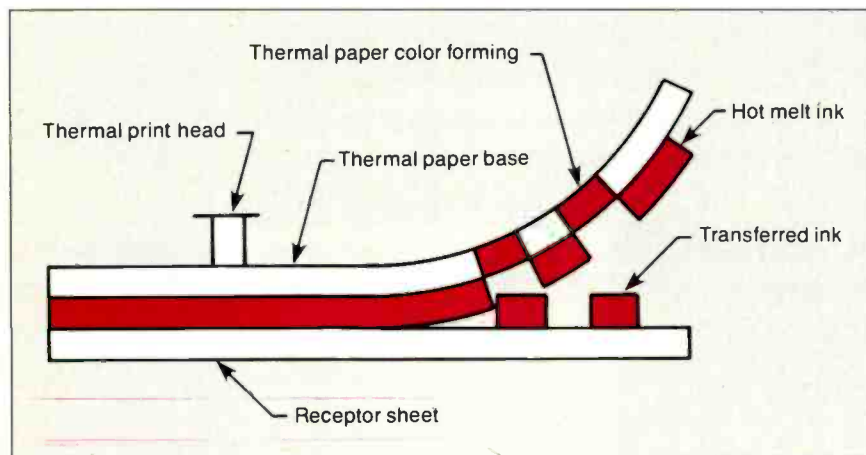

Figure 5: How thermal-transfer printing works. To print in color and on plain paper, you use a ribbon composed of blocks of the subtractive colors, which you overprint to obtain the various colors.

Thermal Transfer

Thermal-transfer printers come in two varieties: serial (moving-head) printers and fixed-head page printers. Although both types lay down color similarly and require the same kind of media, they vary significantly in price. The serial printers, usually appealing to home users, cost less than \$300. The page-oriented systems, primarily used for engineering output (in many cases for proof copies, due to output-size limitations) and some new applications such as presentation graphics, cost between \$4500 and \$10,000. Thermal-transfer printing is particularly effective for area fills, since the density of the graphic does not affect print speed in page systems.

Three key elements compose thermal-transfer printing: a thermal head, a ribbon, and paper. The thermal head consists of a set of resistive elements that selectively heat up when an electrical current is applied. Direct-thermal printers, in which the head causes a specially treated paper to darken, have used these heads for a long time. Thermal-transfer printing inserts a wax-coated ribbon between the head and paper. The ribbon is heated from behind, the wax-based ink coating melts, and the image is transferred to the paper (see figure 5). Using a ribbon lets the thermal head print on plain paper and in color.

Like electrostatic plotters, thermal-transfer printers produce color prints through multiple passes of the subtractive primaries. In both serial and fixed-head configurations, the thermal-transfer ribbon has blocks of each subtractive color. In serial printers, these blocks are the same length as the print line: The head traverses the line with one color and then goes back to the beginning of the same line to overprint it with another color, and so on. The print mechanism indexes

continued

Aztec C ... The Best C

Frees the genius in you

You've got a great idea . . .

. . . you're ready to write your programs.

You don't want to be sidetracked by all the paperwork. With Manx Aztec C and the ingenious make function, your creative processes won't get bogged down in program administration and housekeeping. Manx Aztec C has the most sophisticated, hardworking program administrator available to you. Once you've described your project, adding new features or enhancements is simple. You never have to concern yourself with the repetitive, tedious task of rebuilding your systems.

The development process moves quickly. Compiles, assemblies, link edits . . . all finish in record time.

Manx Aztec C is the fastest, most efficient C development system in the industry. Benchmarks show it . . . reviews commend it . . . users praise it.

You're ready to test the program. You're ahead of schedule. The Manx Aztec C Source Level Debugger shows you the exact C language statement giving you a problem. You fix the problem quickly . . . you're still ahead of schedule.

You've got some time for fine tuning. The Manx Aztec C Profiler examines your program, tells you where the slow spots are and validates your test procedure. A few changes and it's exactly what you wanted.

You've made it!

Aztec C is available for MS-DOS/PC DOS. Call for details on Macintosh, Amiga, Apple II, CP/M-80, CP/M-86, TRS-80, ROM and others.

To order, or, for information

Call Today

1-800-221-0440

In NJ or outside the USA call
(201) 542-2121

30-day satisfaction guarantee. Special Discounts are available to professors, students, independent developers, and on a "trade-in" basis. Site licenses.



Manx Software Systems
One Industrial Way
Eatontown, NJ 07724

" . . . a superb linker, a profiler, an assembler, and a set of development utilities are only the beginning of this package . . . performed admirably on the benchmarks with short compile times and the best link times in this review . . . includes the most professional make utility . . . documentation is clear and complete. There is no doubt that this is a valuable and powerful programming environment." **Computer Languages Feb. '86**

" . . . execution times are very good, close to the best on most tests . . ." **PC Tech Journal Jan. '86**

" Easily one of the fastest compilers overall . . . library provides a lot of flexibility . . . generates small .EXE files." **Dr. Dobbs Journal Aug. '85**

C'Prime (Compiler, Assembler, Linker)	\$ 99.
Aztec C 86-d Developer's System	\$299.
Aztec C 86-c Commercial System	\$499.
PC ROM (8086, 68000, 8080, or 6502)	\$750.

Third Party Software for Aztec C: HALO, PHACT, C-tree, PRE-C, Windows for C, PC-lint, PANEL, Greenleaf, db Vista, C-terp, Plink-86, FirsTime, C Util Lib, and others.

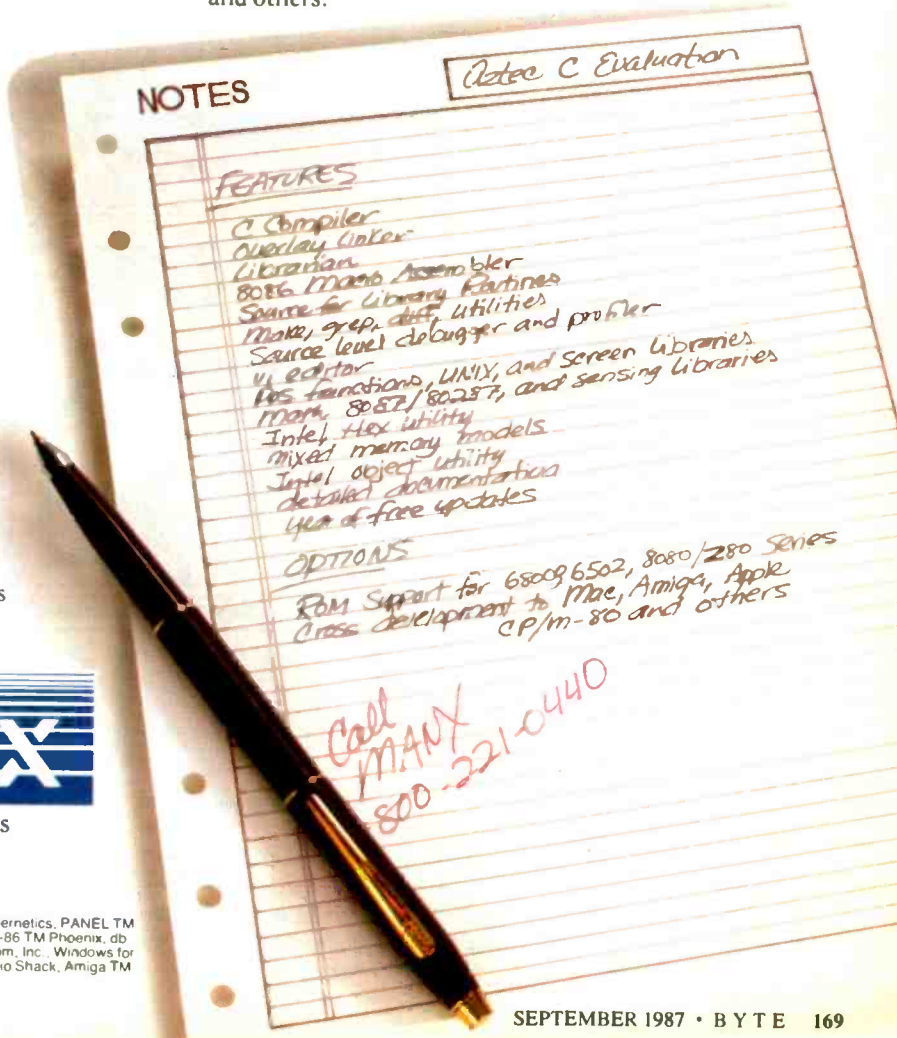

MS is a registered TM of Microsoft, Inc. CP/M TM DRI, HALO TM Media Cybernetics, PANEL TM Roundhill Computer Systems, Ltd. PHACT TM PHACT Assoc. PRE-C, Plink-86 TM Phoenix, db Vista TM Raima Corp. C-terp, PC-lint, TM Gimpel Software, C-tree TM Faircom, Inc. Windows for C TM Creative Solutions, Apple II, Macintosh TM Apple, Inc., TRS-80 TM Radio Shack, Amiga TM Commodore Int'l.

While ink-jet printing is conceptually very attractive, it has a number of problems.

to the next print line only after all three or four colors have printed and the ribbon has progressed to a new block of the first color. In fixed-head page printers, the color blocks are page-size. You must pass the whole page under the head several times, usually by backing the paper up and refeeding it, an approach that offers a registration challenge. The size of these ribbon blocks effectively limits the size of a printed page.

Thermal-transfer printing has several advantages: The serial printers offer the least-expensive color output currently available, while the page printers offer relatively fast print speeds (some systems can print a page in less than a minute), high resolution (the majority of printers now have 200- or 300-dpi resolution), and reliability. The disadvantages of thermal-transfer technology include the

cost of supplies (the ribbons are expensive, and most systems require special "plain" paper with a very smooth finish) and print quality (some users object to the shiny crayon-like output).

Ink-Jet

Ink-jet is the only raster-based technology that prints color in a single pass. This is possible because ink-jet heads have multiple ink nozzles, with at least one per subtractive color. Having several nozzles per color increases overall throughput speed. Because of the need for extensive "plumbing" (connecting nozzles to multiple ink sources), ink-jet printers tend to be more costly than thermal-transfer printers for a given performance class, ranging in price from \$700 to about \$6000. In addition, early systems were plagued with reliability problems, such as clogged nozzles from dried ink, which gave the technology a bad name. Figure 6 is a schematic of an early-model ink-jet printer from Advanced Color Technology.

Ink-jet printing is a true noncontact technology. A print head generates individual ink droplets and propels them to the paper, creating characters and patterns (see photos 1a to 1d).

Three basic classes of ink-jet printers exist: continuous-jet, drop-on-demand, and phase-change. *Continuous-jet* printers employ a stream of ink droplets (typically more than 50,000 per second) issued from print nozzles under pressure. A charge is selectively applied to the droplets, and, depending upon the desired configuration, some droplets are deflected toward and others away from the page. *Drop-on-demand* printers are simpler, forming droplets in the nozzles and ejecting them through appropriate timing of electronic signals. Some systems use piezoelectric crystals that constrict the nozzle; others use small heating elements that cause the ink to temporarily boil and be ejected. An even more elaborate use of heat exists in *phase-change* ink-jet printing. This method liquefies solid ink pellets, ejects them from the print nozzles, and "freezes" them on the paper surface without their *wicking*, or bleeding, into the paper. Phase-change ink-jet printing is uncommon (see the text box "Plastic Ink" on page 174).

While ink-jet is conceptually a very attractive technology and offers good color with moderate supply costs, it has a number of problems. You pay a comparative-

continued

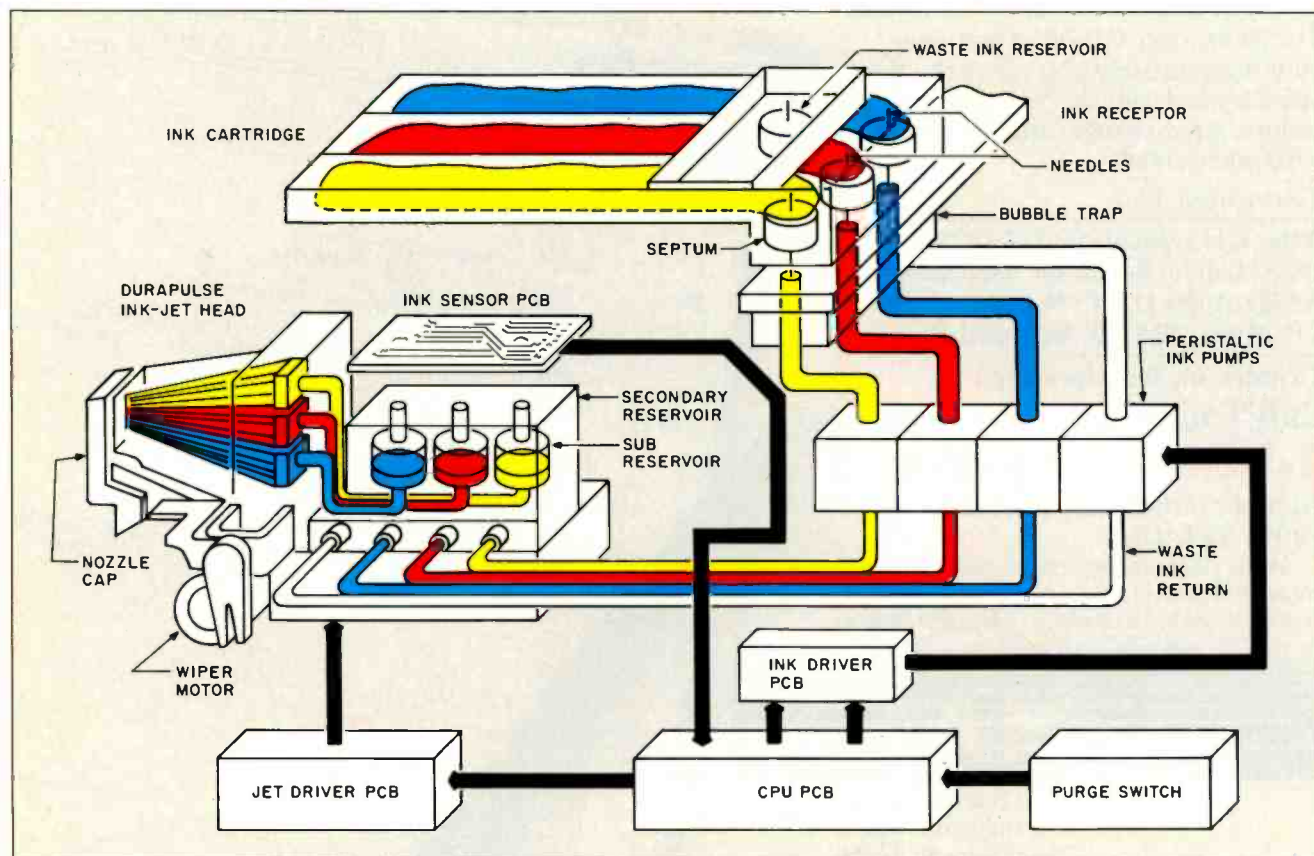
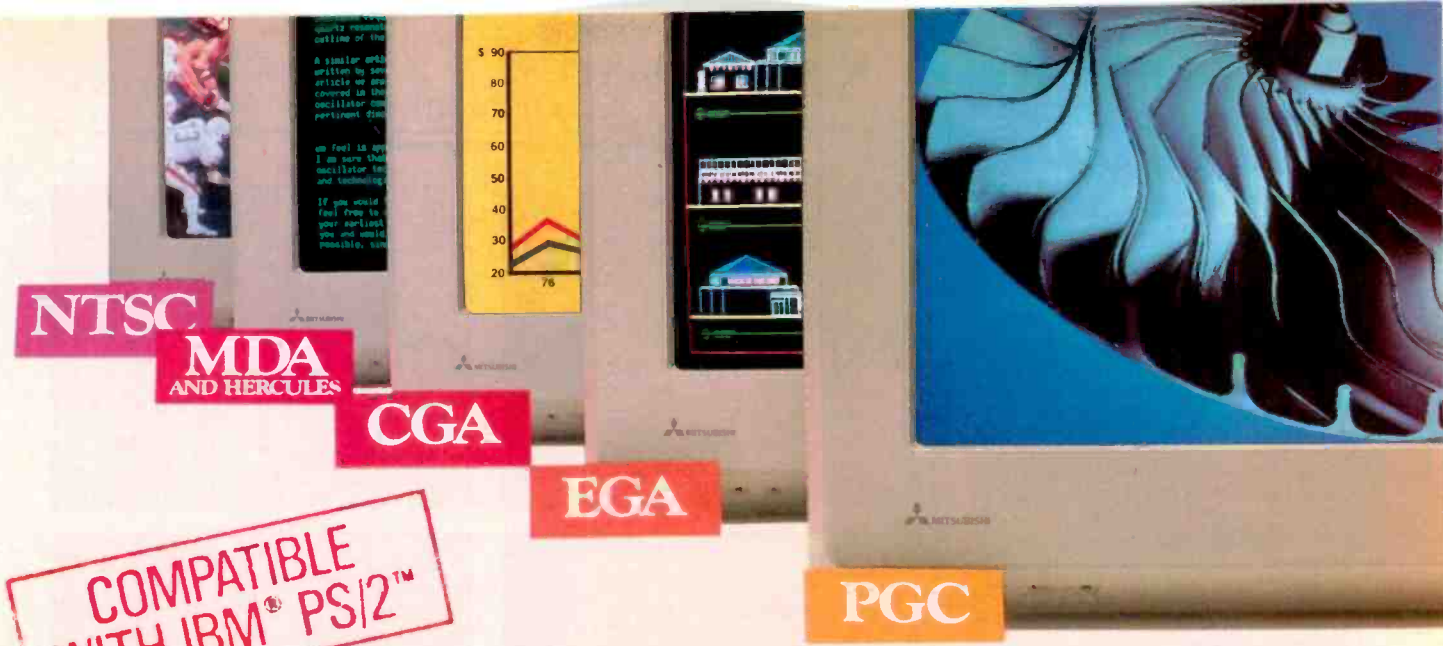

Figure 6: Schematic of a color ink-jet printer from Advanced Color Technology. This is a diagram of an early model but shows the system's complexity and the kind of plumbing it requires.



COMPATIBLE WITH IBM® PS/2™

Mitsubishi Diamond Scan.™ The New Standard In Multi-Application Monitors.

Introducing Model AUM-1371A—The Single Solution Monitor Ideally Suited For Applications Ranging From Monochrome Text To Full-Color, High Resolution Graphics.

Introducing the newest, most versatile high resolution color monitor in the industry today—Mitsubishi's Diamond Scan (Model AUM-1371A).

Actually five monitors for the price of one, the Diamond Scan delivers everything you'll ever need in a multi-application monitor. Including full compatibility with the IBM® PGC/EGA/CGA/MDA and Monochrome Hercules graphics boards. And for even greater flexibility, the Diamond Scan also accepts NTSC video input.

Exceptional design characteristics allow for a resolution up to maximum 800 horizontal dots and maximum 560 vertical lines on a 13" viewing area. What's more, Mitsubishi's Diamond Scan incorporates proprietary auto-scan circuitry which automatically locks onto any horizontal frequency from 15.6KHz to 35.0KHz, and any vertical frequency from 45Hz to 75Hz.



Other advanced design features include a high resolution CRT with .31 dot pitch, automatic screen image adjustment, super-high contrast panel glass for improved visibility and Diamond Matte® coating for maximum glare reduction. All packaged in a compact, ergonomically styled plastic cabinet.

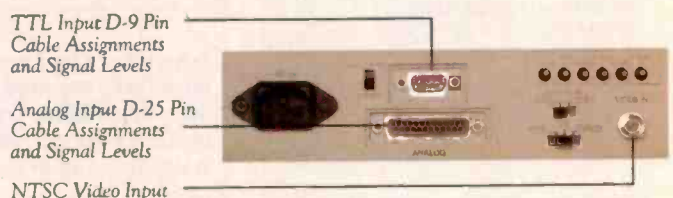

Move up to Mitsubishi's Diamond Scan—the new standard in performance and versatility by which all others will be compared.

For additional information and the location of your nearest distributor, call Mitsubishi today at 1-800-556-1234, Ext. 54. In California, call 1-800-441-2345, Ext. 54. Mitsubishi Electronics America, Inc., Computer Peripherals Division, 991 Knox Street, Torrance, CA 90502.

NEW!

Graphic Board Compatibility*

- | | |
|---|--|
| <input checked="" type="checkbox"/> Quadram QuadEGA ProSync | <input checked="" type="checkbox"/> STB EGA Multi Res |
| <input type="checkbox"/> Orchid Turbo EGA/Turbo PGA | <input checked="" type="checkbox"/> Everex Micro Enhancer |
| <input type="checkbox"/> Sigma Designs Color 400 | <input type="checkbox"/> Hercules |
| <input type="checkbox"/> Video 7 Vega-Deluxe | <input checked="" type="checkbox"/> IBM VGA, PGC, EGA, CGA |
| <input checked="" type="checkbox"/> QDP VIVA 640/800/1000 | <input type="checkbox"/> AST Research AST-3G/Model 1 |
| <input type="checkbox"/> Paradise Auto SW EGA | <input type="checkbox"/> ATI Graphics Solution/EGA Wonder |

*Partial List Only

**We've Got A Great Picture
In-Store For You.**



Inquiry I86 for End-Users.
Inquiry I87 for DEALERS ONLY.

Diamond Scan is a trademark of Mitsubishi Electronics. IBM is a registered trademark of International Business Machines Corp., Diamond Matte is a registered trademark of Mitsubishi Electric Corp. © 1987 Mitsubishi Electronics America, Inc.

UNIVERSAL (E)PROM/PLD MULTIPROGRAMMER™

BYTEK System 125 is based on an advanced modular design concept with support for over **1200 Devices**. Gradually, or all at once, you can build a full Universal MultiProgramming site to program **EPROM/EEPROMs, PLD/EPLD/GALs, PROMs and MICROs**.

BYTEK MultiProgrammers™ offer User Friendly Operation, High Quality, Reliability, and are backed by Dedicated Customer Service, and Unlimited Product Support. **Full One Year WARRANTY, and FREE SOFTWARE** updates. All Products are 100% USA Made.

BYTEK System 125 is the first Universal MultiProgrammer™ (for both the Engineering Laboratory and Production Environments) available at affordable prices.



Model Shown: S125-GL with LogiCel

THREE PROGRAMMERS IN ONE:

- 1. GANG EPROM MultiProgrammer™:** Programs MOS/CMOS/HMOS EPROM/EEPROMs from RAM (standard 256K BYTES, 2048 K Bits) or from Master Device.
- 2. SET EPROM MultiProgrammer™:** 16, 32 and optional 64-Bit Words.
- 3. UNIVERSAL MultiProgrammer™:** (Optional) Logic Array Devices, Bipolar PROMs, 40 pin Micros, 3 Voltage Devices, & EPROM Emulation.

STANDARD FEATURES INCLUDE:

- Stand Alone Operation (Includes DATA EDITing).
- 32 Character Alpha/Numeric LCD
- RS232 Interface for Terminal Mode
- Parallel Printer Port
- IBM PC Software Driver available,

800-523-1565

In FL: (305) 994-3520
FAX: (305) 994-3615
Telex: 4998369 BYTEK

BYTEK offers a variety of products from low cost Dedicated Device Programmers, to Universal MultiProgrammer™ Models.

UV Erasers from \$47.

WRITER: Low Cost Dedicated EPROM Programmers from \$345.

S125 GANG WRITER: \$695
Gang/Set EPROM Duplicator

S125-LADS: \$995
Logic Array Development System



The #1 CHOICE in Programming Equipment.

COLOR PRINTING

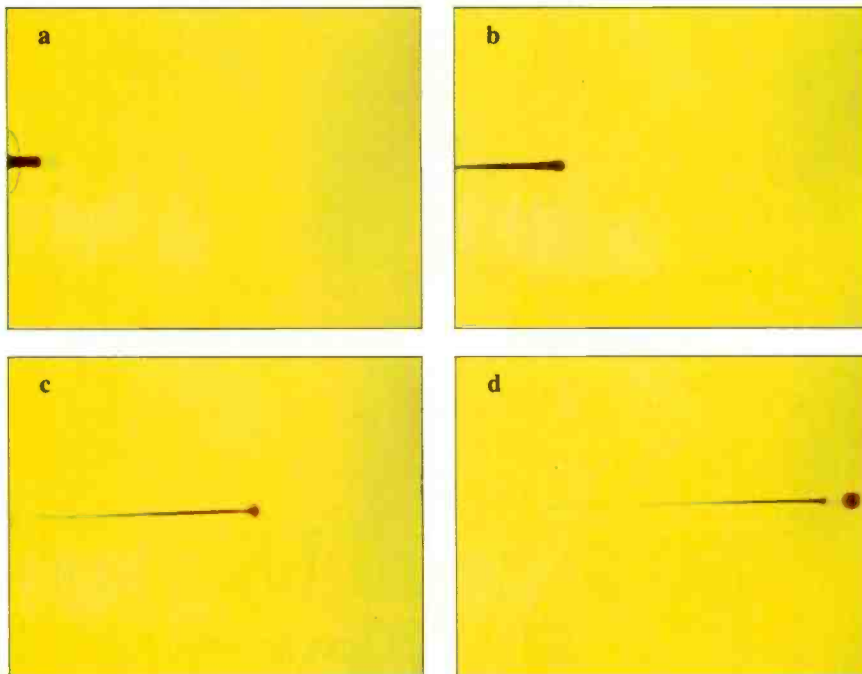

Photo 1: This sequence of photos shows a drop of ink emerging from the print head of the Hewlett-Packard PaintJet color-graphics printer. **(a)** At 25 microseconds, the ink jet is about 0.3 mm long and is still coming out of the nozzle. About half of its length is shown. Note the circular orifice; the ink is going from left to right. **(b)** At 45 μ s, the head of the ink jet has formed and is almost ready to separate from the rest of the ink jet. The tail of the jet is just now exiting the nozzle. The total jet length is about 0.7 mm. **(c)** At 85 μ s, the entire jet is shown and is about 0.73 mm long. The head of the jet is about 1.0 mm from the nozzle and has separated from the rest of the ink jet (note the formation of a circular form at the right end of the jet). **(d)** At 125 μ s, the tail has broken up into separate drops, and the head is about to hit the paper. The drops behind the head are moving quickly and hit the same spot on the paper as the head, creating a single dot.

ly high price for a product of questionable reliability, you need special paper to reduce ink wicking (phase-change ink being the exception), and throughput is generally slow (up to four minutes per color page).

Serial Dot-Matrix

For office use, serial dot-matrix printers are the most popular. However, they have had a limited presence in color applications, even though an increasing number of them have color capabilities. While most configurations are suitable for business graphics or emphasizing text, few can act as a pen-plotter replacement and produce presentation-quality output.

Serial dot-matrix printing is an impact technology. Wires in a print head are fired, striking the ribbon, which releases ink on the paper as the head traverses the print line. As in serial thermal-transfer printing, all colors are overlaid on each print line before moving on to print the next line. Unlike their thermal-transfer counterparts, however, most serial dot-matrix ribbons have horizontal stripes of the colors that run the length of the rib-

bon. The system switches colors by mechanically shifting the ribbon up and down. Most serial dot-matrix printers use CMY, but a few use RGB.

Using serial dot-matrix technology for color printing has some favorable points. It is an established, reliable technology, using low-cost supplies, that offers true plain-paper printing and convenient monochrome operation. The technology does have its shortcomings, however. Hard copy is limited to paper; workable transparencies are generally unavailable. When you need area fills, the output tends to streak, and the color lacks brilliance. In addition, the diameter of the wires in the print head limits the potential resolution; most wires are between 0.007 and 0.014 inch.

Color Electrophotography

An electrophotographic printer is essentially a color copier used as a computer printer. Use of electrophotography for color printing is on the verge of becoming a reality. You could convert a color copier into a computer printer by fitting it with a

continued



Actual unretouched screen image.

Mitsubishi Has A Great Picture In-Store For You.

A High-Quality Line of PC Monitors Priced Below The Competition.

Introducing the Mitsubishi *brand name* family of PC Monitors. Select from five different IBM® compatible models, along with the new IBM PS/2™ compatible XC-1429C. Each has a 13V" diagonal viewing area and proprietary high contrast glass for the sharpest image possible.

Affordably Priced PC Monitors

The XC Series incorporates proven Mitsubishi quality and reliability at an extremely affordable price. In fact, we've included a wide variety of features for which you'd expect to pay considerably more. Like advanced video and deflection circuits to reduce distortion and optional tilt and swivel base for improved ergonomics. Also in-line self-convergence for low power consumption and extra reliability.

The XC Series is available in quantity, ready to support a wide range of application needs—from standard word processing and business graphics to windowing and high resolution solids modeling and CAD.

Complete Customer Satisfaction

Mitsubishi stands behind its brand name XC Series monitors with knowledgeable applications and service personnel and backs each product with a comprehensive one-year warranty. It all adds up to a worldwide reputation for state-of-the-art electronics and unparalleled customer satisfaction.

Compare the picture quality and see for yourself why Mitsubishi monitor displays look so good.

For product literature and your nearest distributor, call Mitsubishi today at 1-800-556-1234 Ext. 54. In California call 1-800-441-2345 Ext. 54. Mitsubishi Electronics America, Inc., Computer Peripherals Division, 991 Knox Street, Torrance, CA 90502.

Inquiry 188 for End-Users.
Inquiry 189 for DEALERS ONLY.



**MITSUBISHI
ELECTRONICS**

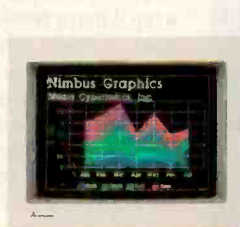
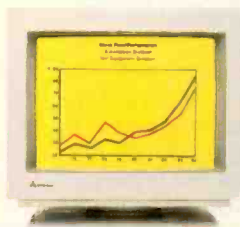

XC-1409C
\$519.00 Sug. Retail
IBM-CGA Compatible
Medium Resolution Monitor:
13V" • 2,000 characters,
640 x 200 graphics resolution
• TTL video input
15.75KHz • 16 colors
0.4mm pitch stripe mask

XC-1410C
\$659.00 Sug. Retail
IBM-EGA Compatible
High Resolution Monitor:
13V" • 2,000 characters,
640 x 350 graphics resolution
• Dual-Mode/TTL
video input 15.75/
22.4KHz • 16/64 colors
0.4mm pitch stripe mask

XC-1430C
\$739.00 Sug. Retail
IBM-EGA Compatible
High Resolution Monitor:
13V" • 2,000 characters,
640 x 350 graphics resolution
• Dual-Mode/TTL
video input 15.75/
22.4KHz • 16/64 colors
0.31mm fine dot pitch

XC-1412C
\$799.00 Sug. Retail
IBM-PGC Compatible
High Resolution Monitor:
13V" • 4,800 characters,
640 x 480 graphics resolution
• Analog video input
30.49KHz • Infinite colors
0.31mm fine dot pitch

XC-1429C **NEW!**
\$685.00 Sug. Retail
IBM-VGA Compatible
High Resolution Monitor:
13V" • 4,800 characters,
640 x 480 graphics resolution
• Analog video input
31.5KHz • Infinite colors
0.28mm fine dot pitch

Plastic Ink

Jane Morrill Tazelaar

Plastic ink? It sounds strange to me, too, but Thermo Jet, an ink-jet technology from Howtek Inc. in Hudson, New Hampshire, uses plastic ink in a combination of phase-encoded and drop-on-demand printing to produce an output similar to embossing with a fantastic variety of colors and attention to detail. The printer surrounding this technology is Howtek's Pixelmaster. It can print digitized images of photographs—you need another unit to do the digitizing—and the "printed" output appears similar to an original painting of the scene. There's almost a three-dimensional quality to it.

Thermo Jet is by no means limited to reproducing photographs. Business graphs are crisp, clean, and clear. Logos resemble those you find on expensive stationery—raised, embossed, shiny, very professional. They look like originals, and indeed they are. Print quality is astounding; it resembles the kind you find on wedding invitations—raised, embossed, high-quality.

How Does It Work?

One of the major problems with many ink-jet printers is the tendency of the ink's solvent to evaporate, leaving dried ink clogging the jets. Plastic ink is loaded dry and serves as its own carrier, so there is no solvent to evaporate; hence, no clogging. Other ink-jet problems include the way in which ink tends

to "bleed" into the paper it is being sprayed on before it dries and the way it smudges if you touch it before it's dry. Plastic ink eliminates these problems because it solidifies immediately on contact with the paper.

Plastic ink is solid at room temperature and has a melting point well above it. Within the Pixelmaster printer, the ink remains in a liquid state because it is kept in a reservoir that is heated to a temperature above the ink's melting point. The print head is also heated. Thus, while the ink remains in the printer, it is liquid. As soon as it leaves that heated environment—conventional piezoelectric crystals apply pressure on the reservoir, expelling the ink through the jet "on demand"—the ink cools and returns immediately to its natural solid state, producing a high-quality, slightly raised output. The solid plastic inks are clean and easily inserted through shape- and color-coded receptacles in the Pixelmaster.

The Pixelmaster Printer

The Pixelmaster comes in two configurations. The Pixelmaster I has 8 jets for each color (black, cyan, magenta, and yellow) and prints a full page of information—either multicolor or black only—in approximately two minutes. The Pixelmaster II comes with 20 black jets and 4 jets for each of the other three colors. It prints a page of black-only text in 30

seconds and a page of color in 4 to 5 minutes. Retail prices for either configuration start at \$4495.

At 240 by 240 dpi by four colors of ink, the Pixelmaster can place as many as 21.5 million dots on an 8½-by-11-inch piece of paper. It can generate up to 64 levels of each of the RGB colors (converted to CMY via proprietary software) for a total of over 250,000 possible color shades. These numbers help to explain the beautiful realism it attains (see the photos). In addition to magnificent colored reproductions, the Pixelmaster can print four-color separations, one color per page, and mirror images, used to produce transparencies.

The Pixelmaster is limited in output size; although geared to office use and supporting letter and A4 paper sizes, it does not support legal and B5 paper sizes. However, it does provide the other normal abilities of an office printer: You can vary lines per inch, page length (within stated limits), margins, number of copies, and so forth. You can integrate all kinds of color images and text on any standard office paper. You can vary the color and thickness of your "pen" and generate truly solid area fills. And you can emulate LaserJet raster-graphic densities. You can print text, fonts, and special characters in a variety of type styles and sizes by inserting the appropriate font card, and reference as many as 120 different fonts or symbol sets at one time, all on a single page if you wish.

The Pixelmaster contains 32 ink jets mounted on a round print head that rotates on an axis concentric to the curved platen. Vertical motion tabs pick up a single sheet of paper from the holder and wrap it into a semicircle around the print head. A slight vacuum holds the top of the sheet against the platen, and the paper moves smoothly past the rotating print head. Since the paper remains at a fixed distance and angle from the ink jets—print-head rotation and paper lift are synchronized—each jet can be aimed and timed to accurately place dots of ink on the paper.

An easily installed Protocol Interface Controller (PIC), a single-board computer built around a 68000 microprocessor with between 512K bytes and 4.5 megabytes of RAM (in 2-megabyte increments), determines the personality of the printer. You can program this imag-



Digitized images of photographs produced by Howtek's Pixelmaster printer using Thermo Jet technology and plastic ink.



ing controller to contain numerous protocols such as page-description languages, emulations of protocols for existing printers, or custom protocols developed for specific vertical applications. You can also add optional hardware interfaces, such as IEEE488, SCSI, and Ethernet. Currently, Howtek supports two protocols: Hewlett-Packard's HPGL and HPPCL LaserJet protocols. PIC cards have also been configured to support Centronics, RS-232C, or GPIB physical communication interfaces.

The print engine in the Pixelmaster includes a slant processor, one of six custom Howtek LSI chips, which transforms the PIC's scan-line data into ink-jet commands. This chip also controls the ink-monitoring and control systems and the heater—an approach that greatly simplifies the software needed to drive the printer.

In All Honesty

I haven't seen the Pixelmaster in operation, and I won't pretend that I have. I am told that using it is as simple as loading the paper and pushing the right buttons. I am told that it runs very quietly. I believe the people at Howtek, but you can't prove these things by me.

What I will stand up and shout about, however, is the most exciting output I have ever seen from an office printer: pictures that seem almost touchable, print quality that is indeed touchable, and brilliant detail and color quality. Plastic ink may sound like a strange idea, but in the world of ink-jet printing, it might turn out to be sheer genius.

data-controlled light source—a laser for a color laser printer. The first such system will probably be available in early 1988. Initial price estimates range from \$20,000 to \$25,000; this is comparable to electrostatic plotters.

Electrophotography is a plain-paper technology; rather than imaging directly on paper as electrostatic plotting does, light exposure creates a charge on a photoconductive drum. These latent images are toned (usually with a dry toner); then the toner is transferred to the paper and fused. In some cases, an intermediate, nonconductive surface receives each color layer before finally transferring it to the page.

Much of the excitement about the potential of color laser printers is based on the tremendous success of their monochrome counterparts. As some prices have dipped below \$2000, these page printers have become an accepted office output device. Experts expect color laser printers to share some of the positive attributes of the current laser offerings and thereby bring color out of specific application niches. Print resolution will be high, probably the 300 dpi that is standard for page printers, and therefore compatible with office-oriented software in monochrome mode. The cost of supplies should be low. And while speeds are likely to be below 10 pages per minute for color output, monochrome pages should run at 20 to 30 ppm.

A Balancing Act

While the growth of color printing has been slower than expected, it is not for lack of color-printing technologies. The task for color-printer manufacturers now is refining those technologies so that you don't lose resolution when you want a large variety of colors, you don't have to take a slow printer in order to get one you can afford, and you can use any sort of paper or transparency that you want with any sort of printer that you have. But this is still in the future. For the present, you must balance price, performance, print quality, and other factors in choosing a color printer or plotter. ■

FOR MORE INFORMATION

The issues discussed in this article and the potential for color in a variety of environments are treated in detail in a new market study by Datek Information Services entitled *High End Color Printers for Emerging Applications*. For more information on this and other Datek reports, write Datek at P. O. Box 68, Newtonville, MA 02160, or call (617) 893-9130. Datek is a research and publishing firm providing focused newsletters, reports, and seminars for the electronic-imaging industries.

LABTECH ACQUIRE

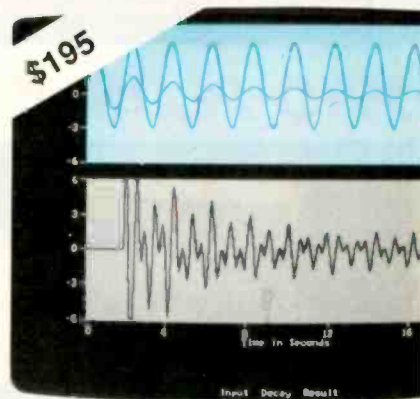

The easy way to collect data

LABTECH ACQUIRE is the newest system from Laboratory Technologies. It is designed for those of you who have relatively simple data acquisition tasks to do, but who don't want to do your own programming or pay the price for a full-blown data acquisition and control system.

Now, with ACQUIRE, you can bring data in from four analog sources and one digital source, display it on the screen, and stream it to disk in real-time. You can even do things normally associated with more expensive systems, like triggering the start of acquisition, and time stamping the data.

Transporting that data to your favorite analysis program is easy. We even supply macros and programs to help you get started.

And if your needs grow in the future, and you want to take data from more channels, work with specialized data channel types, analyze the data in real-time, control your tests, or provide for more generalized triggering, you can move on to the industry standard, LABTECH NOTEBOOK. All of the tests you have set up with ACQUIRE will run unchanged.

And you get all this for only \$195. For information on where to buy along with a list of interface hardware supported by LABTECH ACQUIRE, write Laboratory Technologies or call (617) 657-5400.

LABTECH ACQUIRE is compatible with the IBM PC, XT, AT, or compatibles, and instrumentation interfaces from a large and growing number of manufacturers



Laboratory
Technologies
Corporation

255 Ballardvale Street
Wilmington, MA 01887
(617) 657-5400 • Telex 989695

LABTECH is a registered trademark of Laboratory Technologies Corporation.

MICROSERVE GUARANTEES THE LOWEST PRICE FOR QUALITY COMPATIBLES OR YOUR MONEY BACK!*

PRO-PLUS+™ XT TURBO

PRO-PLUS+™ AT TURBO



**\$659
COMPLETE!**
With One 360k Floppy
and One 20Mb Hard Drive
ONLY \$959

**\$1199
COMPLETE
SYSTEM!**



Requests For Bids
on High Volume
Orders Welcomed

STANDARD FEATURES:

IBM PC/XT Compatible
4/8 MHZ CPU speeds
640k RAM Memory
Two 360k Diskette Drives
150 Watt Switching Power Supply
FCC Approved Chassis
AT Style Keyboard
High-Resolution Amber Monitor
Hercules Compatible Graphics Card
Parallel Port
User Manual
Complete and Ready to Run!

STANDARD FEATURES:

IBM AT Compatible
6/10 MHZ CPU speeds
1Mb RAM Memory
One High Density 1.2 Mb Diskette Drive
Hard/Floppy Disk Controller Card
200 Watt Switching Power Supply
FCC Approved Chassis
Enhanced AT Style Keyboard

High Resolution Amber TTL Monitor
Hercules Compatible Graphics Card
On-Board Clock/Calendar
Parallel Port
User Manual
LAN & Multi-User Ready
Complete and Ready to Run!

**CALL MICROSERVE FOR QUOTES
ON CONFIGURATION OF YOUR CHOICE**

MICROSERVE Computer Products are the Highest Quality and Best Values on PC/XT and AT Compatibles!

HARD DRIVES

Seagate 20Mb w/contr. ST225 . . . \$335
Seagate 30Mb w/contr. ST238 . . . 389
Seagate 20Mb for AT ST225 . . . 289
Seagate 30Mb for AT ST4038 . . . 529
Seagate 40Mb for AT ST251 . . . 629
Seagate 80Mb for AT ST4096 . . . 929

MONITORS

Amber TTL w/Tilt Swivel Base . . . \$119
Color RGB Monitor . . . 279
EGA Monitor w/Card . . . 569

PRINTERS

Panasonic 1080I . . . \$219
Panasonic 1091I . . . 269
Okidata 182 . . . 229
Okidata 192+ . . . 350
Okidata 193+ . . . 525
Citizen 120D . . . 189
Citizen MSP10 . . . 279
Citizen MSP20 . . . 315
Citizen MSP15 . . . 379
Citizen MSP25 . . . 459
Toshiba P321 . . . 445
Toshiba P341E . . . 659
Toshiba P351III . . . 929

**MOST ORDERS SHIPPED
WITHIN 48 HOURS**

TERMS: All prices subject to change without notice. Shipping is FOB Phoenix, AZ. Minimum shipping charge is \$2.50. UPS C.O.D. is \$3.00 additional. Arizona residents only, add 6.7% sales tax. Allow extra two weeks shipping time when paying by personal or company check. No extra charge for MasterCard or Visa orders. All shipments sent insured. A Returned Materi-

al Authorization number obtained from MicroServe in advance must be shown on the shipping label for all returns.

All systems are burned-in and tested for 24 hours. We configure systems boards, set up switches, format hard drives, perform all diagnostics, and check the system with your monitor. All systems are FCC approved: Class 15J, Part B.

* PURCHASE WITH CONFIDENCE!

Here is our commitment to you:

30 Day Money-Back Guarantee — If you are not satisfied with any item you purchase from MicroServe, you may return it within 30 days of the date of shipment for a full refund. Returns must be "as-new", not modified or damaged, with all warranty cards, manuals, and original packing intact, and must be pre-authorized by MicroServe, and be shipped prepaid and insured.

One Year Limited Warranty — MicroServe Corporation warrants the products it manufactures to be free from defects in materials and workmanship for a period of one year from the date of shipment. During this one year period, MicroServe will repair or replace, at its option, any defective products or parts at no additional charge, provided the product is returned, shipping and insurance prepaid, to the MicroServe repair facility.

CALL TOLL FREE:

1-800-621-8285

(In Arizona, Call: 1-252-0017)

IBM PC/XT and AT are registered trademarks of IBM Corp.

176 B Y T E • SEPTEMBER 1987

Inquiry 178 for End-Users. Inquiry 179 for DEALERS ONLY.

Vector-to-Raster Algorithms

Disguising the more intuitive vector information as raster data

Dick Pountain

FROM CRTS TO printers, the world of personal computers contains a multitude of raster devices trying to express vector information. While programs specify formulas, curves, and objects, most of the visual output devices that personal computers use (except the pen plotter) must translate that information into the sequence of dots, or pixels, that a raster device can portray. (While dots refer to printed output and pixels to screen output, there is no difference between the two in terms of raster imaging. Therefore, I shall use the word *dots*, where applicable, to focus on printing, while the word *pixels* would be equally correct were I to focus on displays.)

Made for TV

The archetypal raster device is the television CRT. Even the word *raster* comes from television technology, where it describes the two-dimensional array of horizontal scan lines traced by a flying dot of light as it creates a TV picture (a process called *raster scanning*).

A raster device produces an image by scanning each horizontal line and generating the sequence of dots that it finds, thereby building up a whole picture. The exact sequence of dots is calculated from information found in the operating software. Since raster images consist of separate dots, a raster device can't draw continuous lines like a vector device can. If you have sufficient resolution and slightly overlapping dots, you can maintain the appearance of continuity most of the time, but diagonal lines inevitably contain an element of "jagginess."

Most personal computers use a raster CRT as their primary output device. Some portables use liquid-crystal, gas-plasma, electroluminescent, or other types of flat-screen displays, but you can still categorize them as raster displays although technically they don't produce their displays with a flying dot. What they do have in common is a picture composed of individual pixels, arranged in lines drawn one after the other.

Most of the printers for personal computers are also raster devices. Laser printers print lines of dots in sequence to build up an image on the paper. Most dot-matrix printers have the ability to print both in bit-image mode, a raster process, and in character mode. The daisy-wheel printer is one exception; it prints only whole characters, can't draw arbitrary lines, and gives you no access to the individual dots.

Creating a Good Disguise

Since raster devices are so widespread and vector devices relatively rare, why bother to make the distinction? Because the kinds of data structures and algorithms you need to program the two are fundamentally different. More important, vector representation is much more intuitive to the human mind and far more flexible in use. As so often happens in computing, we are faced with a paradox: We wish all output devices were vector-oriented, but they tend to be raster-oriented. A lot of programming effort goes into disguising the latter as the former.

For example, the natural way to specify a circle would be to provide the coordi-

nates of its center and its radius. A raster display will have none of this; it understands only a sequence of dots on each line. It doesn't care which of these dots fall on the circle and which don't.

The vector description is not only more natural, it is also more flexible and economical. You can represent a circle, at its simplest, with three numbers (x , y , and *radius*). If you need to move the circle, ideally all you must do is change the values of x and y . However, to a raster device, moving the image changes everything, as each dot on the circle will be in a different place.

Some personal computers that support graphics include a BASIC command to draw a circle on a raster device from a vector representation. But at some lower level, either in the BASIC interpreter itself or in the operating system, software is working away furiously to convert this vector representation into a pattern of dots suitable for the raster device, a process called *rasterization*. The special algorithms employed by this process are often called *vector-to-raster* or *scan-conversion* algorithms.

Laser printers increasingly incorporate their own intelligence and rasterization routines, and the performance of their conversion algorithm can have a crucial affect on their speed. Laser-printer ras-

continued

Dick Pountain is a technical author and software consultant living in London, England. He can be contacted c/o BYTE, One Phoenix Mill Lane, Peterborough, NH 03458.

terization can take a lot of processing time because the resolution is more than 10 times that of a typical CRT screen. Many current laser printers contain a processor chip at least as powerful as the CPU in the computer to which they are connected. The use of custom hardware for rasterization is also increasing (see "Designing a Raster-Image Processor" by Jon Barrett and Kirk Reistroffer in the May BYTE).

With a Little Bit

Raster devices that can produce arbitrary graphics images (as opposed to just characters) are usually "bit-mapped." This means that every pixel or dot in the raster image is represented by a bit in computer memory. For example, in a bit-mapped CRT display, the whole screen image is stored as a sequence of bits in an area of computer memory reserved for this purpose, called the display buffer.

The display buffer is accessible not only to the CPU but to a video-controller chip that scans through it at short intervals (60 times per second for most U.S. screens) and translates every 1 bit into a lit pixel on a scan line on the screen. In a laser printer, the bits are used to alter the intensity of the scanning laser beam that creates the paper image.

The process of generating an image now becomes the process of writing the correct pattern of bits into the display buffer. Unfortunately, this is not as straightforward as it seems, for two reasons. First, as a rule, CPUs don't access single bits; instead, they access 8-bit bytes or 16- or 32-bit words. Thus, within memory you must group together the dots making up an image in a manner that bears no relation to the image but is dictated solely by the CPU's word length.

Dots that logically belong to the same image may be spread across many memory words.

Second, the display buffer consists of one long sequence of bytes (or words), whereas the output is composed of a number of separate scan lines. Two dots that are vertically adjacent on the output may be widely separated in the display buffer.

In addition, many manufacturers have devised complex mappings between the display buffer and the raster device; for example, some intersperse color information with bit-mapped data in the same buffer or store scan lines in a different order from that on the output. I shall consider only simple monochrome bit maps, where each bit corresponds exactly to one dot. Some color devices use a number of such simple bit maps, called *bit planes*, to represent the different color components—red, green, blue, and gray—of a colored image, and my observations apply equally to these.

Dissecting Objects into Bit Maps

How can you translate an object described geometrically (e.g., a line or a polygon) into a bit map? The tension between the two ways of representing an image, as an object or as a bit map, runs through all of graphics programming. For example, MacPaint is a bit-mapped drawing program; it turns every picture you draw directly into a bit map.

On the other hand, MacDraw is an object-oriented program; it stores a picture as a set of data structures containing geometric descriptions of the various image components. MacDraw constructs a bit map only when it displays or prints the picture. Thus, you have more flexibility in altering a MacDraw image than you do in modifying one from MacPaint.

In an object-oriented program, each component is a separate object that you can move as a whole, alter in size, or rotate to any angle. The ideal in graphics programs from CAD/CAM to desktop publishing is to keep the data geometrical (and, therefore, flexible) as long as possible, converting to the relatively inflexible bit map only at output time. As well as consuming a lot of processing time, rasterization causes an irreversible loss of information; it is difficult indeed to extract geometrical information from bit-mapped images. You can, however, manipulate them to some extent with the BitBLT operation.

The Plot Thickens

The most primitive operation on a raster device is plotting a single point at an arbitrary location, expressed in device coordinates (the number of dots by the number of scan lines). However, even this operation is not trivial. You must convert the device coordinates to the memory address of the appropriate word and then set the correct bit within that word using logical masking operations. To make things worse, you often have to count from the wrong end of the word to find the correct bit, a *bit-reversed* format:

```
dot    0 1 2 3 4 5 6 7
       x x x x x x x x
       7 6 5 4 3 2 1 0   bit
```

Listing 1 contains Plot, a pseudocode algorithm for plotting, which assumes the bit-reversed format. [Editor's note: *This article uses the following conventions: square brackets, [x], mean "the contents of memory location x"; ^ means "raised to the power"; and the logic operators OR, AND, and NOT are bit-wise operations rather than Boolean ones. All the algorithms given are in pseudocode.*]

In practice, you wouldn't actually employ multiplication and division as I have in listing 1. A plotting routine must be as fast as possible, since printing ultimately depends on it, and it will be executed billions of times. You should always write it in machine code and optimize it using every trick your instruction set offers.

You should also replace all the multiplication, division, and power operations with logical left and right shifts. For example, if your word length is 8 bits and you have 640 dots per line, you want a routine that operates like FasterPlot (see listing 2). A faster, but more hardware-specific, solution would be to eliminate y coordinates from the calculation by precomputing the address of every scan line on the device and storing them in a lookup table.

continued

Listing 1: Plot, a pseudocode algorithm for plotting a single point at an arbitrary location.

```
Program Plot(X,Y)
Address  <- BufferStartAddress + QUOTIENT((X +
      Y * PixelsPerScanline) / BitsPerWord)
BitNumber <- (BitsPerWord - 1) - REMAINDER((X +
      Y * PixelsPerScanline) / BitsPerWord)
Mask     <- 2 ^ BitNumber
[Address] <- [Address] OR Mask
```

Listing 2: FasterPlot, a more efficient version of listing 1.

```
Program FasterPlot(X,Y)
Address  <- BufferStartAddress + (X SHIFTR 3) +
      (Y SHIFTL 6) + (Y SHIFTL 4)
Mask     <- 128 SHIFTR (X AND 7)
[Address] <- [Address] OR Mask
```

If you ever wanted to take a crack at assembly language,

now's the time.

You probably already know that assembly language subroutines are the smartest way to get the fastest programs.

But if the complexities of working in assembler made you think twice, here's some good news. We've made Microsoft® Macro Assembler Version 5.0 a lot easier to use.

We eased the learning process by giving you the best support around. We completely revised our documentation. The new Mixed Language Programming Guide gives you step by step instructions for linking your assembly code with Microsoft QuickBASIC, C, FORTRAN, Pascal and other languages. And you get a comprehensive reference manual with listings of the instruction set and examples of each instruction. We didn't stop there, though. You also get an on-disk collection of templates and examples.

We've also dramatically simplified the high-level language interface. In just a few



simple steps, you can be calling Macro Assembler subroutines from programs written in your favorite language.

Now that you're writing the fastest programs, Microsoft is giving you the fastest way to debug them. For the first time, we've added our CodeView® debugger to Macro Assembler.

With source code and comments on your screen, Microsoft CodeView makes debugging programs containing assembly language subroutines a snap.

And you'll be glad to know that you don't sacrifice any speed for all the ease of use.

We took the fastest Macro Assembler on the market and made it even faster.

So what are you waiting for? Get your hands on Microsoft Macro Assembler and see what it's like to break your personal speed limit.

Microsoft®

For more information or for the name of your nearest Microsoft dealer, call (800) 426-9400. In Washington State and Alaska, (206) 882-8088. In Canada, call (416) 673-7638.

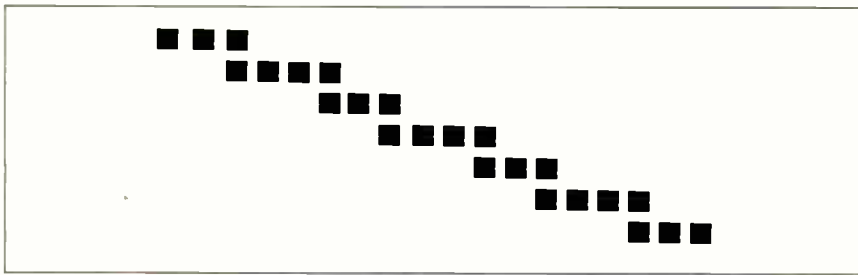

Figure 1: The staircase effect achieved when you try to plot a straight diagonal line on a raster device.

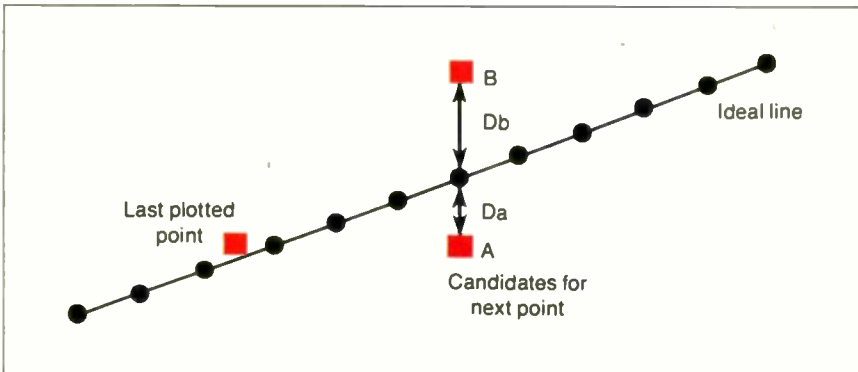

Figure 2: A diagram of Bresenham's method for determining which point to plot next to come closest to the ideal of a particular line.

For screen applications, you may want a second version of Plot that replaces the OR operation on the Mask with a bit-wise XOR. This produces the effect of plotting a black pixel on white areas and a white pixel on black areas, while replotting the same point erases it. You can use drawing routines based on this primitive to draw over any image and then restore the previous image; this is one way to provide a screen-cursor symbol or a rubber-band box for grabbing screen areas.

Once you can plot a point, you need a routine that can draw lines. Line plotting on a raster device bears little resemblance to geometry, where $y = Mx + C$ (M being the slope and C a constant). Instead of plotting in continuous two-dimensional space, you are trying to plot onto a grid of discrete points.

You cannot, in general, plot a straight diagonal line on a raster device; you can only approximate it with a series of steps resembling a staircase (see figure 1). You can use the geometrical formula by computing $y = Mx + C$ for each x (in floating-point arithmetic) and then rounding the value of y to the nearest integer, but it's too slow for practical use.

True raster-line algorithms calculate which of the available dots (from the grid of discrete points) fall closest to the ideal straight line between the two points. To achieve maximum speed, these algorithms avoid multiplication and division. The best are incremental algorithms, where you compute each step from the preceding one.

Bresenham's Line Algorithm

The most widely used raster line algorithm today is Bresenham's line algorithm, discovered by J. E. Bresenham, an IBM researcher, in 1965. This algorithm maintains an error term whose value is proportional to the deviation of the points from the ideal line. If a point has just been plotted, in general, two possible choices exist for the next point (A and B in figure 2), and one of them will be nearer to the ideal line than the other.

Bresenham's error term is proportional to $(Da - Db)$, the difference in distances from the ideal line. In figure 2, A is closer to the line; since $Da < Db$, the error term is negative, and you need to increment only the x coordinate, resulting in a horizontal line segment. If the error term is positive, B is closer to the line, and you increment both the x and the y coordinates, resulting in a step (both a horizontal and a vertical line segment).

Bresenham devised an algebraic derivation of the error term so it can be calculated incrementally, using only integer addition, subtraction, and multiplication by 2 (replaced in practice by a left shift).

Listing 3: BresenhamLine, a pseudocode algorithm for an abbreviated and limited version of Bresenham's line algorithm.

```

Program BresenhamLine(X1,Y1,X2,Y2)
DeltaX ← X2-X1
DeltaY ← Y2-Y1
Error ← -2 * DeltaY - DeltaX
X ← X1
Y ← Y1
FOR Count FROM 1 TO DeltaX
  IF Error > 0
    THEN Y ← Y+1
      Error ← Error + 2 * (DeltaY - DeltaX)
  ELSE Error ← Error + 2 * DeltaY
  ENDF
  X ← X+1
  Plot(X,Y)
    
```

Listing 4: HorizLine, an algorithm for horizontal lines in pseudocode.

```

Program HorizLine(X1,X2,Y)
FirstAddress ← BufferStartAddress + (X1 SHIFTR 3) +
  (Y SHIFTL 6) + (Y SHIFTL 4)
LastAddress ← BufferStartAddress + (X2 SHIFTR 3) +
  (Y SHIFTL 6) + (Y SHIFTL 4)
FirstMask ← 255 SHIFTR (X1 AND 7)
LastMask ← NOT (255 SHIFTR (X2 AND 7))
[FirstAddress] ← [FirstAddress] OR FirstMask
FILL FROM FirstAddress+1 TO LastAddress-1 WITH 255
[LastAddress] ← [LastAddress] OR LastMask
    
```

See BresenhamLine in listing 3. (For space reasons, I have confined myself to a line with an uphill slope of less than 45 degrees; a more generalized version of the algorithm examines the relative magnitudes of $x1$, $y1$, $x2$, and $y2$ and swaps variables appropriately.)

The only true straight lines you can draw on a raster grid are horizontal lines, vertical lines, and the 45-degree diagonal line (which is at an actual 45 degrees only if the device has a square aspect ratio). These special cases are easier to plot, and so they often have their own separate routines that run faster than the general case. For example, horizontal lines occupy contiguous addresses in the bit map; thus, you can plot them noniteratively using a fast memory-fill instruction.

The only trick lies in masking the partial bytes that may occur at either end of the line. Assuming the same hardware characteristics as FasterPlot, HorizLine (see listing 4) ignores the line less than eight dots long that falls within 1 byte; in that case, you should use both FirstMask and LastMask. (Listing 5 contains VertLine, a routine that plots vertical lines.)

You can now combine these horizontal and vertical line routines into a fast box-drawing routine, Box, which you could use, for example, to print forms on a laser printer (see listing 6). In a similar fashion, you could use the general-purpose line routine, BresenhamLine, to write a *polyline* routine that draws a polygon from a list of coordinate pairs that describe its vertices.

Going Around the Bend

You can draw curved lines using just the polyline routine, as a sufficient number of short line segments can approximate a curve; for example, a regular polygon with a sufficient number of sides can approximate a circle. A *sufficient number* is that number that reduces the length of a side to a single dot, for this is as near to a true curve as a raster device can come.

Circles and ellipses are so useful that it's practical to have a fast routine especially for drawing them. The equation for a circle of radius, r , about the origin, 0,0, is $x^2 + y^2 = r^2$. However, plotting this equation directly using floating-point arithmetic and rounding is impractical; the square-root calculation is too slow. Instead, you can use an error term whose value is proportional to $x^2 + y^2 - r^2$ and choose the points that minimize this error.

As in Bresenham's line algorithm, algebraic rearrangement lets you use only simple integer calculations. J. Michener's algorithm is a variation on Bresen-

continued

Listing 5: VertLine, a pseudocode algorithm for vertical lines.

```
Program VertLine(X,Y1,Y2)
FirstAddress  <- BufferStartAddress + (X SHIFTR 3) +
              (Y1 SHIFTL 6) + (Y1 SHIFTL 4)
LastAddress   <- BufferStartAddress + (X SHIFTR 3) +
              (Y2 SHIFTL 6) + (Y2 SHIFTL 4)
Mask          <- 128 SHIFTR (X AND 7)
FOR Address FROM FirstAddress TO LastAddress STEP 80
  [Address]   <- [Address] OR Mask
```

Listing 6: Box, a method for drawing a box using horizontal lines (listing 4) and vertical lines (listing 5).

```
Program Box(X1,Y1,X2,Y2)
HorizLine(X1,X2,Y1)
VertLine(X2,Y1,Y2)
HorizLine(X1,X2,Y2)
VertLine(X1,Y1,Y2)
```

Listing 7: Circle, a pseudocode version of Michener's algorithm for drawing a circle.

```
Program Circle(CtrX,CtrY,Radius);
X <- 0
Y <- Radius
Error <- 3 - 2 * Radius
WHILE X <= Y {generate 8 points from one X and Y}
  Plot(CtrX+X,CtrY+Y)
  Plot(CtrX+X,CtrY-Y)
  Plot(CtrX-X,CtrY+Y)
  Plot(CtrX-X,CtrY-Y)
  Plot(CtrX+Y,CtrY+X)
  Plot(CtrX+Y,CtrY-X)
  Plot(CtrX-Y,CtrY+X)
  Plot(CtrX-Y,CtrY-X)
  IF Error > 0
    THEN Error <- Error + 4 * (X-Y) + 10
       Y <- Y-1
    ELSE Error <- Error + 4 * X - 6
  ENDF
  X <- X+1
ENDWHILE
```

Listing 8: FilledCircle, a modification of listing 7 that fills the circle as it is drawn.

```
Program FilledCircle(CtrX,CtrY,Radius);
X <- 0
Y <- Radius
Error <- 3 - 2 * Radius
WHILE X <= Y
  HorizLine(CtrX-X,CtrX+X,CtrY+Y)
  HorizLine(CtrX-X,CtrX+X,CtrY-Y)
  HorizLine(CtrX-Y,CtrX+Y,CtrY+X)
  HorizLine(CtrX-Y,CtrX+Y,CtrY-X)
  IF Error > 0
    THEN Error <- Error + 4 * (X-Y) + 10
       Y <- Y-1
    ELSE Error <- Error + 4 * X + 6
  ENDF
  X <- X+1
ENDWHILE
```

ham's: To gain speed, you compute only one-eighth of the points on the circle, the 45-degree slice from 12:00 to 1:30; the rest is deduced on the grounds of symmetry (see Circle in listing 7). Again, you would actually implement the multiplications as left shifts.

Curve-fitting algorithms can be used to handle arbitrarily curved lines. However, these are usually reserved for sophisticated CAD/CAM systems and are not yet routinely implemented on laser printers or other personal computer raster devices. The principle of a curve-fitting algorithm is to roughly sketch out a path by plotting a number of guide points and then fitting to them the nearest curve the

algorithm can find using pieces from different cubic curves. Cubic curves take the form $y = A*x^3 + B*x^2 + C*x + D$ and have the happy property of fitting together smoothly where they join.

A typical application for a curve-fitting algorithm would be smoothing the wire-frame drawings of aircraft or car designs on a CAD workstation. (For a fuller account of Bézier and B-spline methods for curve fitting, see "Free-Form Curves on Your Micro" by Steve Enns in the December 1986 BYTE.)

Fill It Up, Please

Once you can draw boxes, polygons, and circles, you want to be able to fill them

with a solid color. The fastest way is to do it when you are drawing the original shape, for that's when the coordinates of each point on the shape are available. For example, you could modify Circle (see listing 7) into FilledCircle (see listing 8) by drawing horizontal lines between symmetrical pairs of points, instead of just plotting them.

A filled box is similarly produced from a sequence of horizontal lines. Filled polygons, however, present more of a challenge; you must find the points at which each horizontal scan line intersects with the edges of the polygon. If you are drawing a concave polygon, there may be more than two such points for some lines. The resulting algorithms are complex and involve keeping sorted tables of the intersection points and the polygon edges.

Filling arbitrary outlines after they have been drawn is a difficult process, but one that an interactive drawing program might require. Once you have drawn a shape, information about its outline exists only in the bit map; extracting that information is painful. You must write a routine that reads the value of a dot from the bit map, the exact reverse of Plot, so that you can detect the edges of the region to be filled. IsSet (see listing 9) returns the value "true" if the point x,y is turned on and "false" if it is not (i.e., if the dot has the background color).

The simplest fill algorithm is the flood fill, which is more common in screen applications. It searches in all directions from a chosen start point for pixels that are not set and then sets them; the process resembles water flooding across a floor. Filling stops when the flood reaches the boundary of the shape. That boundary must consist of an unbroken chain of set pixels; if it has any holes, the flood will leak out and fill the area around the shape, a common experience for users of drawing software. The algorithm is most clearly expressed in the recursive form shown in FloodFill (see listing 10).

FloodFill examines the four nearest neighbors of each point: left, right, up, and down. In topological terms, it fills a 4-connected region. You could easily expand it to examine eight neighbors (including the diagonally adjacent pixels), but this expansion can cause the flood to leak through boundaries drawn using any variant of Bresenham's line algorithm, since they have "holes" in the diagonal directions (see figure 3).

This recursive flood fill uses an enormous amount of stack space when you run it over sizable areas on a high-resolution device. Iterative versions that overcome this problem are less elegant; they identify horizontal "runs" of pixels to be

Listing 9: IsSet, a pseudocode routine to determine whether a particular bit in a bit map is a 0 or a 1.

```
Function IsSet(X,Y)
Address <- BufferStartAddress + (X SHIFTR 3) +
          (Y SHIFTL 6) + (Y SHIFTL 4)
Mask <- 128 SHIFTR (X AND 7)
Value <- [Address] AND Mask
IF Value = 0 THEN RETURN FALSE
ELSE RETURN TRUE
```

Listing 10: FloodFill, a pseudocode algorithm in recursive form that floods an area in order to fill it.

```
Program FloodFill(X,Y)
WHILE NOT IsSet(X,Y)
Plot(X,Y)
FloodFill(X-1,Y)
FloodFill(X+1,Y)
FloodFill(X,Y-1)
FloodFill(X,Y+1)
ENDWHILE
```

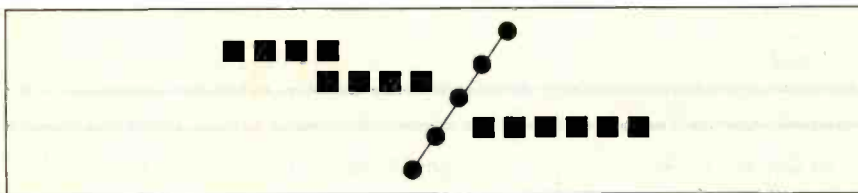

Figure 3: This shows how a flood fill can leak through the "holes" in a diagonal line.

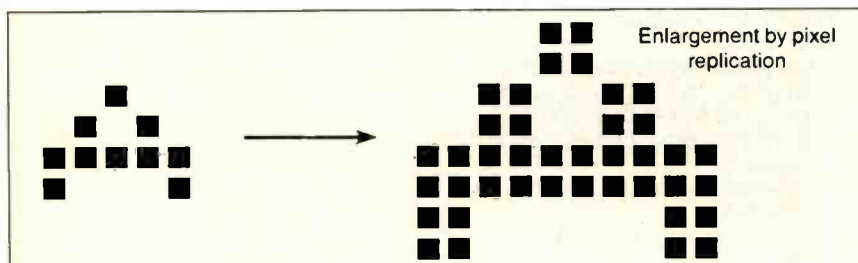

Figure 4: This shows the only method of enlarging a character stored in bit-mapped form—pixel replication.

filled by searching along each scan line to find where it intersects with the boundary.

What a Character!

The drawing primitives we have seen can produce text characters on a raster device, but this is not usually the primary method of displaying text. It's far too slow to draw a letter *A* using line- and maybe curve-drawing primitives every time you press the *A* key. Instead, on "soft" systems like the Macintosh, Amiga, and most laser printers, characters are normally stored in nonvisible RAM as a set of bit maps that make up a complete font and then copied to the display buffer as needed. If you have a character-only device, the font lives in ROM, and the display hardware copies it directly.

More sophisticated typesetting systems employ a two-stage process. They store the fonts as vector descriptions and then convert them to bit maps in font memory, using algorithms like those above. From font memory, the bit maps can be copied to the display buffer on demand. The advantage of this approach is that you can produce different sizes and styles of characters from the same description by applying geometric transforms—you might slope a font to italicize it—while preserving the display quality.

Donald Knuth's METAFONT is an example of a system that describes typefaces geometrically in terms of curved segments. The PostScript page-description language can also compute bit maps from mathematically described fonts.

By contrast, fonts that are stored solely in bit-mapped form are relatively inflexible. You can enlarge them only by the crude process of replicating the dots (i.e., by printing two or four dots for each one in the original character). This has the profound disadvantage of magnifying the jaggedness of the original in proportion and leads to unsightly characters in the larger point sizes (see figure 4). The alternative is to store a separate font bit map for each point size, which uses a lot of memory. (Transforming bit-mapped characters is limited to rotation in multiples of 90 degrees.)

Bit Blitting

The operation used to copy characters to the display buffer has become famous as the BitBLT or Blit operation, short for bit boundary block transfer. The basic Blit operation copies the bits that represent a rectangular area of dots from one place (the source) to another (the destination) in memory.

The source and destination may both lie in the display buffer, or the source

may lie elsewhere, such as in font memory. Dots need not be aligned on word boundaries, hence the bit-boundary tag; therefore, much of the algorithm is concerned with masking out parts of bytes that fall outside the source or destination rectangles. It must also cope with the various cases where the source and destination rectangles overlap (they might even be the same rectangle).

The most general form of Blit can combine the source and destination rectangles using logical operations rather than simply copying, for example, *source XOR*

destination. With it, you can obtain many special effects, such as characters with transparent backgrounds or characters overprinting each other, perhaps, for accents. (For a good description of the use of the BitBLT operation in kerning characters for a laser printer, see "Designing a Raster-Image Processor" in the May BYTE.)

BitBLT is, in theory, a general operation that can serve as the sole graphics primitive in a system (it was used this way by its inventors, the Smalltalk team at the

continued

UNIX TOOLS FOR YOUR PC

NEW VERSION

PC/VI™

UNIX's VI Editor Now Available For Your PC!

Are you being as productive as you can be with your computer? An editor should be a tool, not an obstacle to getting the job done. Increase your productivity today by choosing PC/VI—a COMPLETE implementation of UNIX* VI version 3.9 (as provided with System V Release 2).

PC/VI is an implementation of the most powerful and most widely used full-screen editor available under the UNIX operating system. The following is only a hint of the power behind PC/VI:

- Global search or search and replace using regular expressions
- Full undo capability
- Deletions, changes and cursor positioning on character, word, line, sentence, paragraph, section or global basis
- Editing of files larger than available memory
- Shell escapes to DOS
- Copying and moving text
- Macros and Word abbreviations
- Many controllable options including Auto-indent, Showmatch and Wrap Margin
- Filter text through external programs AND MORE!

Don't take it from us. Here's what some of our customers say: "Just what I was looking for!", "It's great!", "Just like the real VI!", "The documentation is so good I have already learned things about VI that I never knew before." — *IEEE Software*, September 1986.

PC/VI is available for IBM-PC's and generic MS-DOS† systems for only \$149. Included are CTAGS and SPLIT utilities, TERMCAP function library and an IBM-PC specific version which enhances performance by as much as TEN FOLD!

PC/TOOLS™

What makes UNIX so powerful? Sleek, Fast, and POWERFUL utilities! UNIX gives the user not dozens, but hundreds of tools. Now the most powerful and popular of these are available for your PC! Each is a complete implementation of the UNIX program. Open up our toolbox and find:

• ASA	• COMM	• DIFFH	• MAKE	• SED	• TAIL
• BANNER	• CMP	• DIFF3	• MV	• SEE	• TAR
• BFS	• CP	• FIND	• OD	• SORT	• TR
• CAL	• CUT	• GREP	• PASTE	• SPLIT	• TOUCH
• CAT	• DATE	• HEAD	• PR	• STRINGS	• UNIQ
• CHMOD	• DIFF	• LS	• RM	• SUM	• WC

All of these for a limited time introductory price of only \$49.00. Extensive documentation is included!

PC/SPELL™

Why settle for a spelling checker which can only compare words against its limited dictionary database when PC/SPELL is now available! PC/SPELL is a complete implementation of the UNIX spelling checker, renowned for its understanding of the rules of English! PC/SPELL determines if a word is correctly spelled by not only checking its database, but also by testing such transformations as pluralization and the addition and deletion of prefixes and suffixes. For only \$49.00, PC/SPELL is the first and last spelling checker you will ever need!

Buy PC/VI and PC/TOOLS now and get PC/SPELL for only \$1.00! Site licenses are available. Dealer inquiries invited. MA residents add 5% sales tax. AMEX, MC and Visa accepted without surcharge. Thirty day money back guarantee if not satisfied! Available in 5¼", 3½" and 8" disk formats. For more information call today!

*UNIX is a trademark of AT&T. †MS-DOS is a trademark of Microsoft.

CUSTOM SOFTWARE SYSTEMS
P.O. BOX 678 • NATICK, MA 01760
617 • 653 • 2555

UNIX TOOLS FOR YOUR PC

Inquiry 68

SEPTEMBER 1987 • BYTE 183

SUNDAY 10-5 **PROMPT DELIVERY**

COMPUTERS

APPLE
Macintosh Plus 1 MB RAM 1999.99 CALL
2.800K Floppies

COMPAQ 386
1 MB RAM 1.2 Floppy CALL

COMPAQ PORT.
Portable III-Model 20 1.1 2 MB F D CALL
640K RAM 4199.99
Portable III-Model 40 1-1 2 MB RAM 4199.99

Epson Equity I Plus
512K RAM 2-360K Floppies DOS GW Basic w Ky bd CALL

IBM System/2
Model 30 640K RAM 1-3 5 F D 20 MB H D CALL

IBM System/2
Model 50 1-1 4 MB F D 1 MB RAM 20 MB H D 02599.99

IBM System/2
Model 60 1-1 4 MB F D 1 MB RAM 44 MB H D CALL

PRINTERS

BROTHER
In Stock
HR-40 179.99
HR-60 309.99
M-1109 319.99
M-1409 429.99
M-1509
M-1709
M-1724

CITIZEN
MSP-10
MSP-20
MSP-25
MSP-50
MSP-55

IBM
Pro Printer II
Pro Printer-24
Pro Printer XL-24
Quietwriter III

EPSON
FX-86e
FX-286e
LQ-800
LQ-1000
LQ-2500

LASER PTR.
Canon Series II 1599.99 CALL
Epson QVC-3500 1679.99 CALL
HP Laser Series II 1679.99 CALL
HP Laser Plus-500 1349.99 CALL
Okidata Laser
Everex 2400 Ext. 269.99
Hayes 2400-B 279.95 CALL
U.S. Robotics 79.99
1200-B 169.99
2400-B 289.99

MODEMS
Paradise EGA-480 289.99
Quad EGA Pro Sync 299.99
Video I Deluxe 289.99

EGA CARDS
NEC GB-1
Paradise EGA-480 289.99
Quad EGA Pro Sync 299.99
Video I Deluxe 289.99

LAP TOP COMP.
NEC Multi Speed 2649.99 CALL
T-1100 Plus 1549.99
Twist Screen 2249.99
Toshiba T-3100
Zenith Z-181
Zenith Z-183

GUARANTEED LOWEST PRICES
COMPUTER: 1-800-874-1235
VIDEO: 1-800-223-6779
HOURS: Mon-Thurs. 9-6
Fri. 9-2, Sun. 10-5, Sat. Closed

S & W COMPUTERS & ELECTRONICS
31 West 21 Street, New York, N.Y. 10010

TOLL FREE OUT OF N.Y.
IN N.Y. CALL (212) 463-8330

C.D.D. Accepted
Credit Card Accounts charged at time of order. * Add ship. hand. ins. * Price, subject to change without notice * Not responsible for typographical errors.

Xerox PARC). It does not belong to the class of conversion algorithms that are the subject here, because it is an operation on bit maps rather than a producer of bit maps.

However, far from being a rival to scan conversion, BitBLT is highly complementary. An image that has been scan-converted to a bit map can be moved around using BitBLT to save having to draw it again, as with font characters.

BitBLT is the best way to scroll a screen, for example, by copying the whole screen one line upward and then erasing the bottom line by XORing it with itself or by copying in the next image line. The BitBLT operation is also good for creating overlapping windows and simulating the movement of objects on the screen. However, it is not a good way to draw arbitrary lines and curves or to fill arbitrarily shaped areas.

Blitting large areas can consume a lot of processing time, and there is an increasing tendency to implement BitBLT directly in hardware, as in the Amiga's blitter chip and graphics coprocessors like the TMS34010. The latter chip also supports scan-conversion primitives to draw lines and fill areas.

A Raster in Vector Clothing

The ideal computer output device would allow randomly oriented lines and areas to be drawn directly by merely specifying their display coordinates. However, in the real world, we have to simulate such a device using cheaply available raster-scan devices like the television CRT tube and the dot-matrix printer.

A lot of ingenuity has been expended on the algorithms necessary to make this simulation work efficiently, but the user and the high-level-language programmer seldom see the complexity of vector-to-raster conversion, because it is taken care of in the operating system, language compiler, or even by the hardware.

The field of vector-to-raster conversion is by no means yet closed. New algorithms for polygon filling are still being discovered, and the application of BitBLT to multicolor displays is a recent development. As laser-printer technology advances into color, antialiasing (i.e., disguising jagged lines by shading the edges with varying-intensity dots) promises to become a hot topic. ■

BIBLIOGRAPHY

- Foley, J. D., and A. Van Dam. *Fundamentals of Interactive Computer Graphics*. Reading, MA: Addison-Wesley, 1982.
- Newman, William M., and Robert F. Sproull. *Principles of Interactive Computer Graphics*. New York: McGraw-Hill, 1979.

COPY II® PC OPTION BOARD

AN ALMOST FOOLPROOF WAY TO MAKE ARCHIVAL BACKUPS OF PROTECTED SOFTWARE!

The Copy II PC Option Board is an easy-to-use add-in board that will give your PC the same disk duplication technology used by most disk duplication firms (who put the copy protection on software in the first place).

DUPLICATES NEARLY ALL PROTECTED DISKETTES.

The Option Board can easily backup almost all protected diskettes for the IBM PC, including ones software-only backup programs can't touch. It even includes a track editor that will allow the more technically inclined to look at protection schemes and edit any data on a diskette.

The Option Board uses a half-size slot in an IBM PC, XT or AT, Heath/Zenith 150, 151, 158, Compaq Deskpro. Requires: 1 360KB drive, 256K memory. Extra \$15 cable required for Compaq Portable, HP Vectra and Tandy 1000.

Call 503/244-5782, M-F 8-5 (West Coast time) with your in hand. Or send a check for \$95.00 U.S. plus \$3 s/h, \$15 overseas. Please specify your computer brand when ordering so we can send you the correct cable.

\$95.00

Central Point Software, Inc.
9700 S.W. Capitol Hwy., #100
Portland, OR 97219

Central Point Software
INCORPORATED

Backup utilities also available for the Macintosh, Apple II, Commodore 64/128 and Atari ST.

Star has ImagePower Printers for:

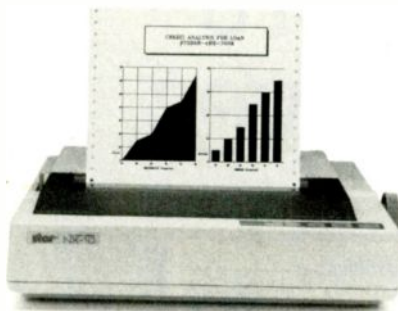

Bankers...

NX-10 offers flexibility and value; with 120 cps Draft mode, and 30 cps Near Letter Quality, for credit and loan reports.

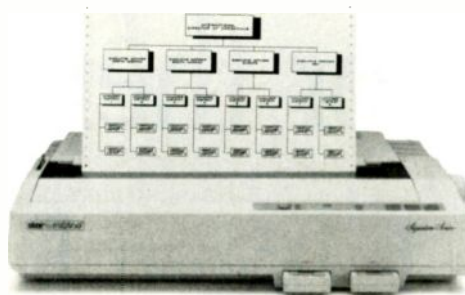

Executives...

The Signature NB24-15 features professional-looking Letter Quality at 72 cps, with high resolution graphics.



Students...

Budget-minded students like the NP-10. Draft at 100 cps; and crisp NLQ looks great in class.



Editors...

The ND-10 meets deadlines with a fast 180 cps Draft mode, time-saving 12.6K buffer. Plus, crisp NLQ.

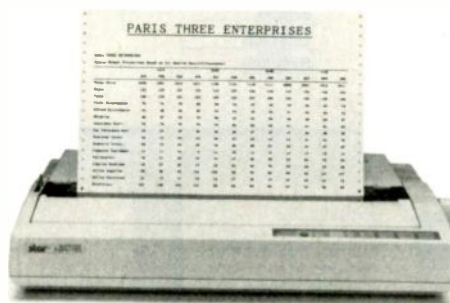

Accountants...

Spreadsheets fly out of the NR-15 at a fast 240 cps Draft; plus features that make numbers look more impressive.

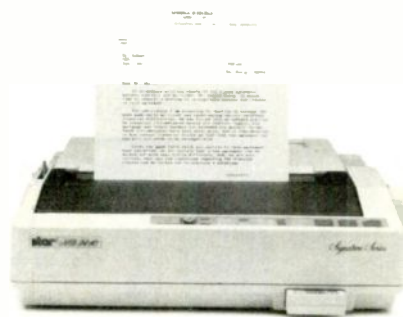

Lawyers...

Signature NB24-10 prints drafts at 216 cps, true Letter Quality at 72 cps, for faultless legal briefs.

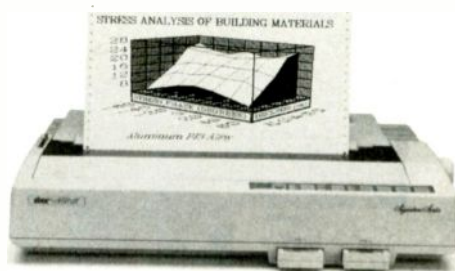

Engineers...

NB-15, our fastest Signature, with a 15" carriage perfect for number crunching and design work; 300 cps Draft, 100 cps LQ.

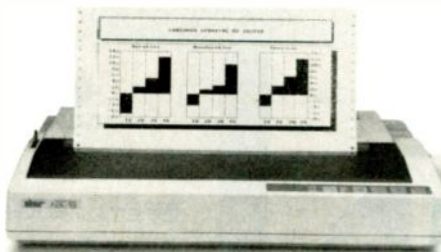

Retailers...

They're sold on the NX-15; prints inventory reports and spreadsheets at 120 cps Draft, or 30 cps NLQ.

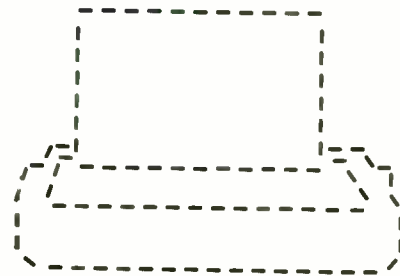

And you.

Whether you need spreadsheets, graphics, or word processing, Star has an ImagePower™ Printer to make your work, and you, look your very best.

The 24-wire Signature Series offers impeccable Letter Quality print-outs, outstanding graphics,

and terrific speed. Star's 9-wire models combine print quality and speed, without squeezing your budget.

And every Star printer features a convenient front control panel – placing important functions right at your fingertips. Plus, built-in tractor

and friction feed paper-handling features are included as standard.

To find out where you can get a Star ImagePower Printer that's right for you, call 1-800-447-4700.

star
micronics

THE IMAGEPOWER PRINTERS

Our laser printers speak for themselves.



Desktop Publishing

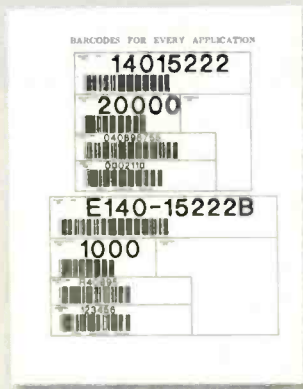

Bar Codes

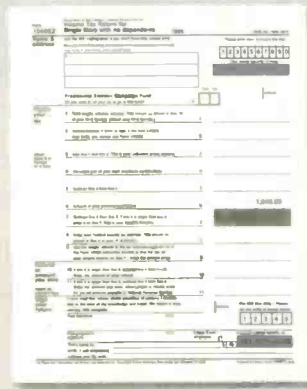

Custom Business Forms

Spreadsheets

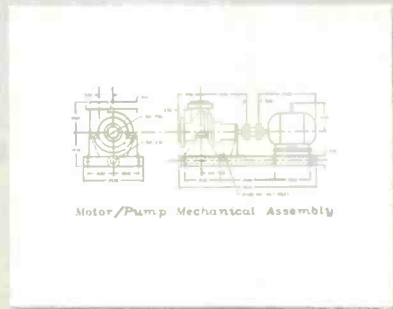

CAD/CAM Drawings

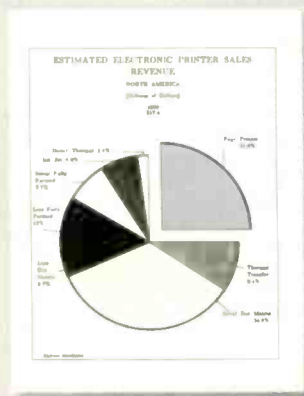

Business Text and Graphics



Letters, Memos and Reports

Select from a wide range of LaserPro laser printers. High quality printing at eight to fifteen pages-per-minute. Software compatibility with virtually all packages that support the Hewlett-Packard LaserJet PLUS™, HP LaserJet™, Diablo® 630, Epson® FX-80, Qume Sprint® II, NEC Spinwriter® and other popular printers. Prices begin at \$1,895*.

For more information, call (800) 732-4589. In California, call (800) 732-4588. Office Automation Systems, Inc., 8352 Clairemont Mesa Blvd., San Diego, CA 92111.

*Suggested U.S. retail price

Inquiry 198 for End-Users. Inquiry 199 for DEALERS ONLY.

LaserPro™

By Office Automation Systems, Inc. (OASYS)



The EXPRESS Personal Printer Line



LaserPro Shared Resource Printers

LaserPro™ is a trademark of Office Automations Systems, Inc.
LaserJet PLUS™ and LaserJet™ are trademarks of Hewlett-Packard Corp.
Diablo® is a registered trademark of Xerox Corporation.

Epson® is a registered trademark of Epson America Corporation.
Qume® is a registered trademark of Qume Corporation.
NEC Spinwriter® is a registered trademark of NEC Information Systems, Inc.

Page Printers

*New technologies help laser printers and their cousins
cost less and produce better results*

Rick Cook

TODAY'S PAGE PRINTERS have two problems. The first is obvious: price. At a time when a very good printer costs less than \$1300 and a less capable unit can sell for under \$200, laser printers start at \$1700 and go up quickly.

The second problem is resolution. For traditional computer-printing jobs, the 300-dot-per-inch resolution of current-model page printers is more than adequate. However, the advent of page printers has spawned new applications—notably, desktop publishing—where 300 dpi is not always good enough. Traditional graphics-reproduction methods for typesetting and photography use resolutions of 1000 to 2400 dpi.

Help is coming on both fronts, thanks to new technologies such as LED, liquid-crystal-shutter, and ion-deposition imaging, and to traditional market forces such as volume production and changes in the design philosophy regarding printer intelligence. In this article, I'll survey the present technology and look at some of the developments that promise to make page printers even more powerful and versatile and, in some cases, less expensive.

How a Page Printer Works

Most page printers use electrostatic forces to create a page image from rasterized digital information and to transfer that image in the form of toner onto a piece of paper.

The heart of an electrostatic page printer is a drum or belt coated with a photoelectric substance that develops a positive or negative charge in response to

light. The usual coatings are selenium and some organic compounds. A beam of light (or an array of individual light sources) "writes" an image onto the drum one row of dots at a time (see photo 1). As each row of dots is written out, a stepper motor advances the drum by one row and the light source writes out the next line of the image.

The result is a 1000-volt electrostatic image of the page on the drum, against a background potential of about 100 V. As the drum rotates, it passes over a reservoir of toner, finely divided particles of an organic compound that is susceptible to static charge. The charged areas on the drum attract and hold the toner. The toner-laden image on the drum is then brought into contact with a sheet of paper that has been charged to an even higher potential, usually about 2000 V, by means of a corona mechanism. The toner jumps to the paper in the same way that bits of lint will jump up and cling to a vinyl comb. Heated rollers fuse the toner to the paper to produce the finished page, and the paper-handling system passes it to the output tray.

After transferring the image onto paper, the drum rotates past a discharge wire to eliminate any remaining charge. Then a scraper assembly removes the last traces of toner, leaving the drum clean and ready to receive the next image.

Figure 1 illustrates the entire system (for a laser printer) schematically, but don't be misled: The process is not simple. A good laser printer is a tightly coupled system of electronic, chemical, optical, and mechanical parts. This intricacy

and interaction of technologies is largely responsible for the laser printer's high cost.

Consider just one element: the image drum (or belt, in some designs). The drum must rotate smoothly, precisely, and concentrically. If it is out of round or mounted eccentrically, the light will be out of focus on the surface at some points, and any spot of toner left at that point will be too large. Furthermore, if the drum does not advance smoothly and accurately, the rows of pixels will be blurred or misplaced. Getting the required precision from the drum movement takes a good stepper motor, quality bearings, and a drum manufactured to close tolerances.

Because these active elements have to be so closely matched, manufacturers buy them as preassembled "engines" from one of the OEMs, such as Canon, Ricoh, and Kyocera. The end-product manufacturers then add a controller, a paper-handling mechanism, and other components to make a complete printer.

Kinds of Page Printers

Laser printers were the original page printers and are still the most widely used variety. They have been available for about 10 years, starting on printers for large computer systems and filtering down to microcomputers. Today, laser-printer technology is widely available and

continued

Rick Cook is a freelance writer specializing in computers and high technology. He can be reached at 3820 West Flynn, Phoenix, AZ 85019.

generally well-understood.

These printers use a laser beam to write the image onto the drum. The laser isn't aimed directly at the drum. Instead, it is aimed at a rotating mirror, usually with 8 to 16 faces, that scans the beam across the face of the drum, turning on and off according to the digital information coming from the rasterized image. The controller synchronizes the scanning beam and the drum-advance motor with the flow of rasterized information.

Small laser printers that produce fewer than 10 pages per minute generally use a laser diode to produce the beam. Faster printers use a more powerful helium-neon or argon laser; the power of the beam determines how quickly the laser can charge the individual points on the drum.

Compared to other kinds of page printers, the biggest design challenge as-

sociated with laser printers is their optical system. To work properly, the laser printer's beam must be equally strong and precisely focused at every point along the scan line. It must also be aligned with the drum and synchronized with its rotation.

Any scanning beam is subject to what are called cosine-fourth losses, named for the function that describes them. (The losses are proportional to the fourth power of the cosine of the angle between the beam and the scanned surface.) As a result of these losses, the beam is weaker and more diffuse at the edges of the scan than at the center. Laser printers use a complex lens system designed to compensate for these losses. Likewise, the faces of the rotating mirror need to be precisely aligned and perfectly flat. Any irregularity will cause misalignment of a row of pixels.

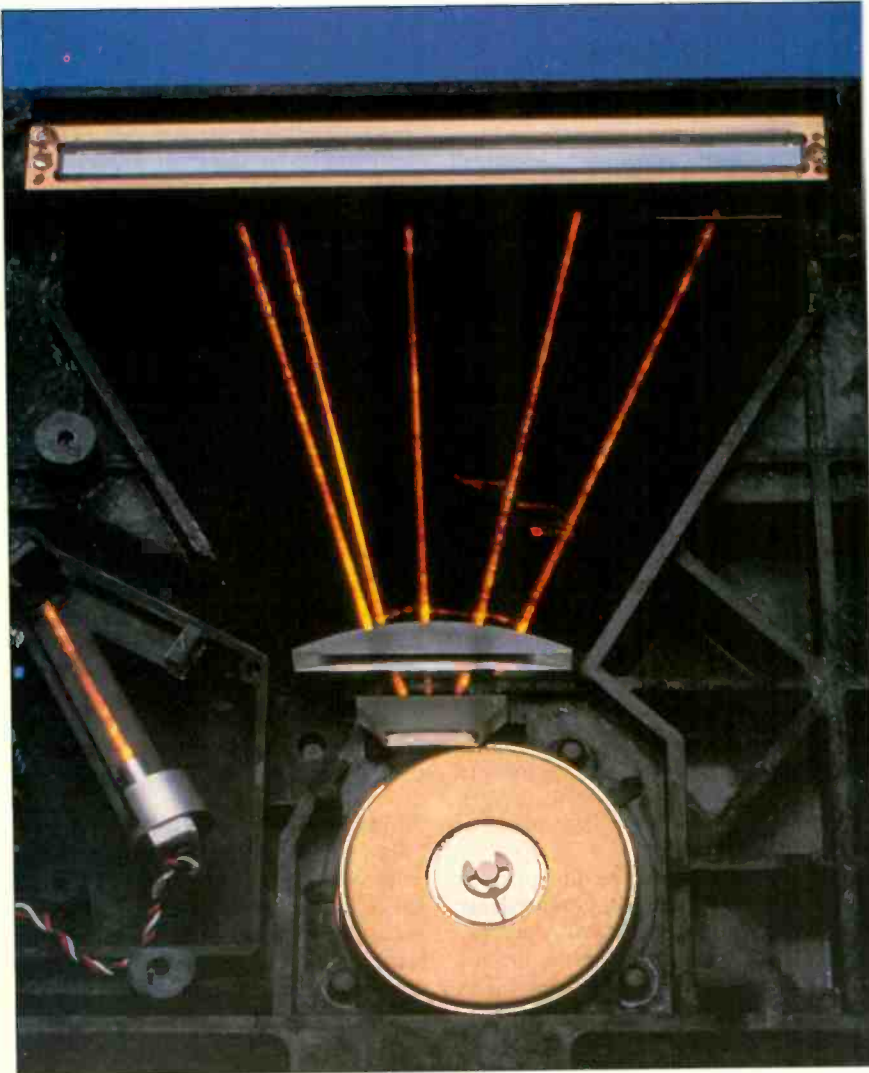

Photo 1: Inside a laser printer. This photo was taken using timed exposures on a laser phosphor card, creating a visible trace of the invisible infrared beam. (Photo courtesy of Xerox Corp.)

Finally, the optics have to be held in precise alignment with the drum and each other. Vibration or misalignment can ruin a laser printer's print quality. (This is one of the reasons laser printers are so heavy, but transformers needed to produce the high voltages also contribute weight.) If a laser printer's optical system gets knocked out of alignment, it is not simple to repair; the unit generally has to go back to the manufacturer.

Although the laser-beam design is the most common approach to writing an image on the electrostatic drum, other designs are available and offer certain advantages. One type of page printer uses a row of LEDs, one for each pixel in the row, to write the image to the drum. Datasouth now offers an LED printer (the Pagewriter 8, \$2995) based on an NEC print engine.

LED engines are made by NEC and Sanyo at the low end (less than 10 ppm), Kentek and Agfa at the medium range (more than 12 ppm), and Kodak at the high end (up to 92 ppm).

A third variation is the LCS printer, which has a row of liquid-crystal "shutters" in place of the diodes. A powerful fluorescent bulb provides the light, and pulses of electricity open and close the shutters to write the image. Taxan sells an LCS printer (the Crystaljet, \$3495). Figure 2 shows an LCS print head.

Because LED and LCS printers use fixed, multiple light sources rather than scanning a beam across the drum, they are optically simpler than a laser printer. Alignment is easy to maintain, and you can replace the print bar (the part that holds the LEDs or LCSs) in the field in a few minutes.

This optical simplicity is somewhat offset by the need to drive each light source individually, which increases the electronic complexity. Most LED and LCS printers multiplex the control signals to cut down the number of signal lines. However, this means that all the light sources cannot be on at once—the printer has to write different sections of the scan line at different times. In some designs, the light bar is mounted at an angle to the drum's rotation to let it write to only part of the drum at once.

In both LED and LCS printers, the number of elements in the print bar determines the resolution. The difficulty of packing the light elements densely enough to achieve high resolution is one of the reasons LED and LCS printers came later than laser printers. In the case of LED printers, the devices must be packed onto LSI chips. For instance, the NEC engine in the Datasouth LED printer uses LEDs built on chips with LSI technology, 128 LEDs per chip. In the

LCS printers, the shutters had to be much smaller than previous applications had demanded (see photo 2).

The LCS design poses an additional problem: The heat from the light source tends to distort the cells in the array. The solution has been to minimize the light intensity and to engineer the print bar to handle the strain.

A close relative of electrostatic printers is the ion-deposition printer, which uses a beam of charged particles (ions) rather than a beam of light to write the image on the drum.

Like LED and LCS printers, an ion-deposition printer uses a row of elements to write to the drum. The elements are conceptually similar to a triode vacuum tube with ions flowing from cathode to anode, regulated by a grid. Unlike other page printers, these printers do not use heat to fuse the toner to the paper. The drum is much harder than the light-sensitive ones used in laser, LED, and LCS printers, making it feasible to cold-fuse the toner particles onto the paper by means of a pressure roller. As a result, the printer generates less heat. Figure 3 is a schematic illustration of the ion-deposition design.

Ion-deposition technology offers a number of advantages in medium-to-high-speed printers, most notably durability. In a laser printer, 500,000 copies per drum is considered excellent performance, and some printers will do only 15,000 copies before the drum needs replacement. By contrast, C.Itoh claims that the drum on its ion-deposition printer will print between 1 and 3 million copies before it must be replaced. These printers have fewer moving parts than laser printers—contributing to the design's reliability.

Moreover, the drum's hardness lets it stand up to harder scraping than is possible with an electrostatic drum. More of the excess toner particles are removed, resulting in fewer "freckles" on the pages.

Ion-deposition printers are basically volume devices. Although the technology could be used in a desktop printer, it tends to be more expensive in low-volume applications than electrostatic systems. Furthermore, because the rollers have to press the toner onto the paper, ion-deposition print has a shiny ("calendered" is the technical description) look that some people find objectionable.

Cutting Costs

One way to cut the cost of page printers is to build a lot of them. As production increases, economies of scale set in and the cost of making a page printer drops. Copiers are made in much larger num-

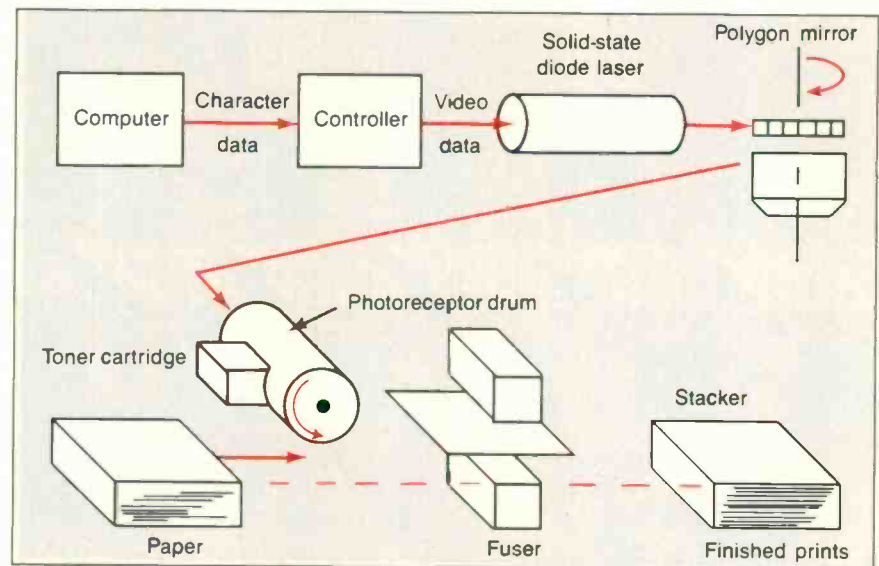

Figure 1: A schematic diagram of a laser printer. Raster-scanned light from a laser is deflected by a mirrored cylinder to expose the surface of a photoreceptor drum. The charged areas attract toner to the drum, which is then transferred to paper and fused on by heat.

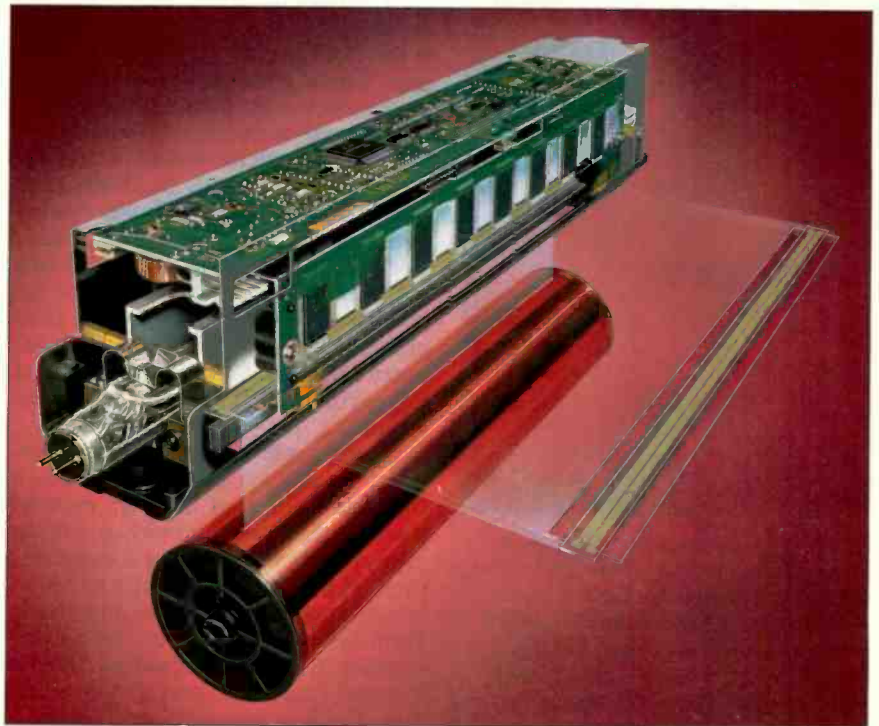

Figure 2: The print-head assembly of an LCS printer. The fluorescent bulb in the head provides light to the shutters, which open and close according to commands from the controller, charging selected dots on the photoreceptor drum. (Figure courtesy of Taxan USA Corp.)

bers than laser printers, one of the main reasons a plain-paper copier sells for half the price of a laser printer.

Other page-printing technologies, such as LED and LCS, can also push down prices. Currently, LED and LCS printers are no cheaper than laser printers. But

laser printers have been made for longer and in larger volumes than LED and LCS designs. Manufacturers claim LED and LCS prices will drop as they move farther along the learning curve and production increases.

continued

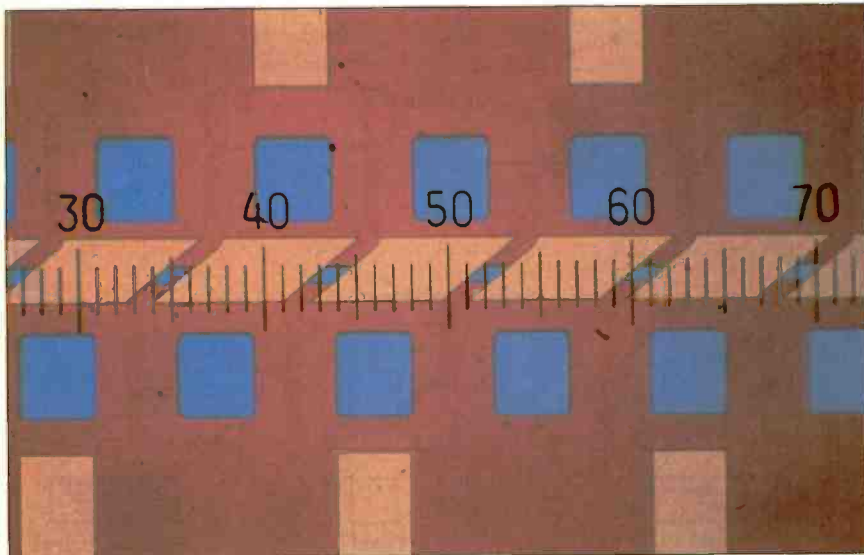

Photo 2: A photomicrograph of part of a shutter array on an LCS print head. (Photo courtesy of Taxan USA Corp.)

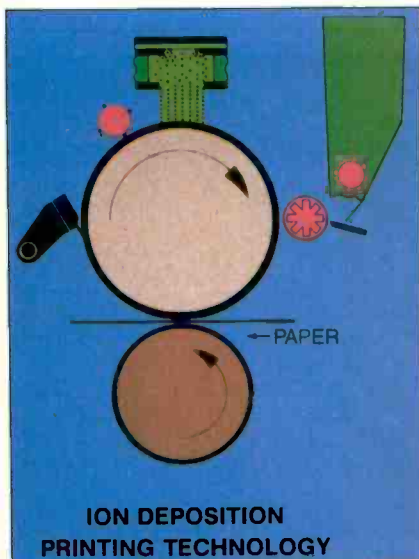

Figure 3: A schematic diagram of an ion-deposition printer. A modulated ion source (top) similar to that in a triode electron tube generates the ions, which are directed onto the drum, forming a latent image. The image attracts toner from the cartridge, which then is pressure-fused onto paper passing between the drum and a pressure roller. (Figure courtesy of C. Itoh Electronics Corp.)

The declining cost of electronic components, especially RAM, helps, but so much of a printer is electromechanical that prices probably won't drop as rapidly as they have for computers.

Another way to cut the cost of a page printer is to reduce its intelligence. Moving the rasterizing and image-storage

components from the printer to the computer reduces the cost of the printer significantly. The amount of actual savings to the user depends on whether the computer's main processor and memory are used to control the printer, or whether a full-featured computer-on-a-board must be added through an expansion slot. For example, Atari's \$1500 SLM-804 laser printer uses a separate controller box between the printer and the computer. Apple is also reportedly taking this tack (i.e., taking the intelligence out of the printer) with its new design for a laser printer that will supposedly list for between \$2000 and \$2500. IBM's Personal Pageprinter (\$2199) uses a similar approach.

On the negative side, when the computer handles the control functions, a complete bit map of the page must be passed to the printer for every copy of the page printed. Without a fast communications channel, printing will be slow. Some companies, such as Electronic Form Systems and TallTree, use a video interface to keep the speed up. IBM's Personal Pageprinter uses a video interface. The least expensive way is to use a serial or parallel interface and just accept the slower speed.

Increasing the Resolution

Aside from lower cost, what users want most from a page printer is higher resolution.

At 300-dpi standard resolution, the page printer falls in an uncomfortable middle ground. The quality of text and graphics on a 300-dpi page printer is superior to that from other kinds of computer printers but not as good as the type-

set material found in books and magazines. Traditional typefaces can only be approximated on a 300-dpi device (see the text box "Page Printer Typography" on page 194). In particular, half-tone images suffer on a page printer (see the text box "A Gray Area for Page Printers—Photography" on page 192).

The minimum resolution on typesetters today is about 1200 dpi. If inexpensive page printers could print at that resolution, they would be much more useful. In fact, doubling the current resolution to 600 dpi would be good enough to handle most graphic-arts jobs. Book-quality work printed on coated stock would still be out of reach.

In the next 24 months, you will probably see a number of 600-dpi desktop page printers. But, for a variety of reasons, they will cost much more than the 300-dpi models.

As a printer's resolution increases, so does its cost of manufacture. The individual dots have to be made smaller, and their placement must be more precise. This is true for both vertical and horizontal resolution.

Increasing horizontal resolution requires better optics, especially on laser printers, because the effects of the cosine-fourth losses become more significant; at higher speeds and densities, the power level is more critical. Increased resolution also requires more precise control of the light source. On a laser printer, that means more accurate mirrors and more precise scanning. LED and LCS printers need more elements in the print bar and the ability to turn the elements on and off more quickly.

The accuracy of the drum-advance mechanism basically determines vertical resolution, since the drum must advance by one pixel for each new row of pixels. That means a better stepper motor and other components, as well as more precise electronic control.

Another consideration is the size of toner particles. Generally speaking, the smaller the average size of the toner particles, the higher the printer's resolution can be. However, the smaller the particles, the harder they are to control. A page printer is basically an electrostatic material-handling system where the material handled is toner. Ideally, there should be no charge anywhere except where the printer puts it, there should be no attraction among toner particles, and the particles should not move except in response to applied static fields.

In practice, however, toner particles are attracted to each other, they adhere to the drum, and they are influenced by stray electrostatic forces within the

continued

FORTTRANS- MIGRATION.

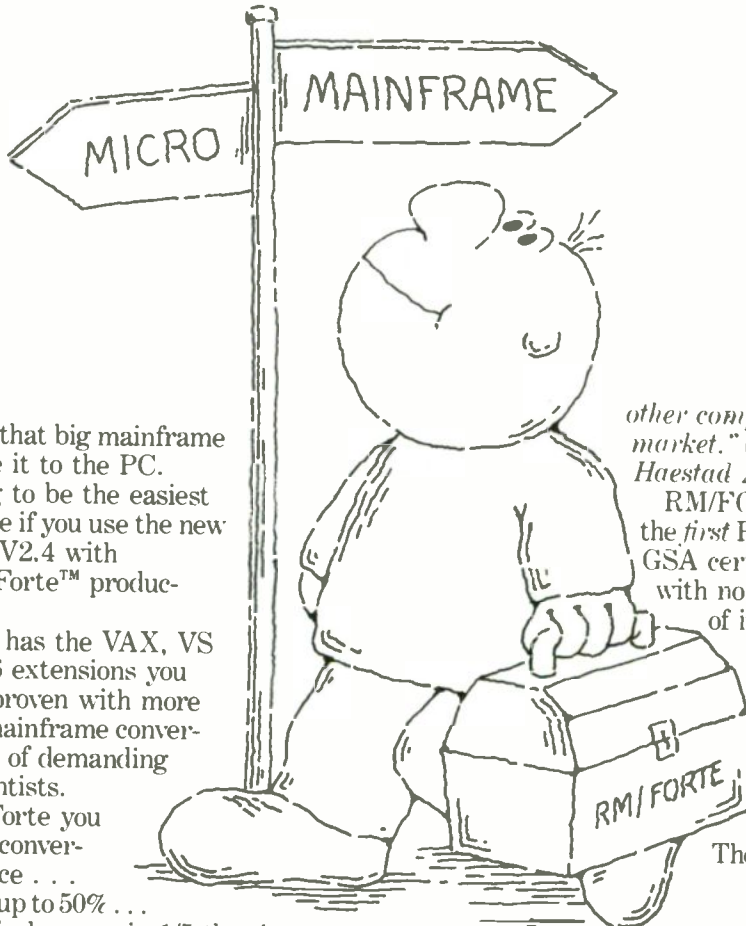

It's moving day.

Time to pack up that big mainframe program and move it to the PC.

Relax. It's going to be the easiest move you ever made if you use the new RM/FORTRAN™ V2.4 with Austec's new RM/Forte™ productivity tools.

RM/FORTRAN has the VAX, VS and FORTRAN-66 extensions you need, and is field-proven with more than two years of mainframe conversions by thousands of demanding engineers and scientists.

And, with RM/Forte you can complete your conversion at a record pace . . . cutting debug time up to 50% . . . diagnosing syntactical errors in 1/5 the time. You're in the fast lane because RM/Forte integrates all major program development tasks—edit, compile, link and debug—into one interactive, menu-driven environment. Just a few simple keystrokes move you from one task to another . . . and back again.

Plus, you get a full screen editor, a syntax checker and a source code manager that automates compiling and linking as you make changes.

RM/FORTRAN applications are more than just easy to develop—they run fast, too. Sieve or Whetstones, RM/FORTRAN benchmarks ahead of the bunch. And if you need it, RM/FORTRAN has a very fast 8087/80287 emulator to give you the power of a coprocessor.

But don't take our word for it. Listen to a moving professional: "RM/FORTRAN lets us move mainframe programs to PC's faster and cleaner than any

other compiler on the market." (John Haestad, Haestad Methods)

RM/FORTRAN was the first PC FORTRAN GSA certified a Full Level ANSI 77 with no errors. You may have heard of its sister, IBM PC Professional FORTRAN.

Enough reading. Start writing. Fill out and send in the coupon below to find out more about RM/FORTRAN with the new RM/Forte productivity tools. Then move it!

**OFFICIAL
SUPPLIER
IBM
FORTRAN/2**



Austec Inc.
609 Deep Valley Drive
Rolling Hills Estates, CA 90274
Or call 213/541-4828

Let's get moving. Send me details on RM/FORTRAN V2.4 with RM/Forte Productivity Tools, and your special upgrade offer. B-9

Name _____
Company _____ Title _____
Street _____
City _____ State _____ Zip _____
Phone () _____

A Gray Area for Page Printers— Photography

Photographs are a challenge for today's page printers. While text printed at 300 dpi might look beautiful to the casual observer, photographs rendered at the same resolution are decidedly second-rate. The reason for this is best summed up in two words: continuous tones.

The typical black-and-white photograph consists of continuously varying tones of gray. An artist attempting to copy a black-and-white photo can recreate the grays by mixing varying amounts of black and white paint on a palette. Of course, that solution isn't feasible in mechanical reproduction systems such as printing presses, which work with only one shade of ink. Because of this fundamental limitation, photographs and other continuous-tone images must go through a process known as screening before they can be mass-printed.

Photographic Screening

In the screening process, a grid of dots or lines called a screen is placed over the photograph, and a new photograph is made. The resulting *halftone* has no gray tones; instead, the gray regions are approximated by means of black dots that vary in size and shape. The density of the screen (i.e., the number of dots or lines per inch) along with certain other factors determines how well the halftone reproduces the original's gradual changes in tone: Higher density allows more gradual changes. Newspaper-quality halftones are typically made with an 85-line screen (i.e., 85 dots or lines per inch); magazine-quality uses a 100- or 133-line screen.

Digital Approaches

The same process can be simulated on a computer. First, the photo is digitized. A scanner moves across the photo just as a print head moves across a page, but, instead of printing, it reads the gray level of the image at fixed intervals. Each sample reading is stored as a number in a given range.

To reproduce the digitized image, the computer creates a bit image made up of small two-dimensional cells. The sampled gray levels are mapped into these cells. To reproduce a gray level from the digitized image, a corresponding per-



Figure A: A Laserport simulation of a 100-line screen, based on a digitized photo provided by Adobe Systems.

centage of pixels within that cell are turned on. For instance, if an 81-dot region is to have a gray level of 25 percent, 20 of the dots inside the cell are turned on.

Resolution vs. Shading

To allow for smoothly varying tones, small cells are needed (just as with the small dots in the halftone screens). But the smaller the cell, the fewer dots can be placed inside it. This, in turn, limits the number of discrete shades that are possible within a cell.

For instance, to approximate a 75-line screen requires 75 cells per inch. At 300 dpi, a page printer can place just 16 (i.e., 4 by 4) dots inside such a cell, yielding only 16 possible gray levels. Note that the resolution is now 75 cells per inch—the image will have only 75 discrete regions per inch, instead of the

300-dpi resolution when only two gray levels, black and white, are represented.

Some printers come with software to accomplish this kind of halftone simulation. Adobe Systems' PostScript, the PDL used in Apple's LaserWriter and certain other models, provides screen for setting the cell size, setscreen for controlling the method of filling pixels inside each cell, and settransfer for applying further transformations to the gray level inside each cell.

The net result of this software-simulated halftoning still falls short of the result of true photographic halftoning. The problem is the shape of the dots.

If you examine a printed photo under a magnifier, you will find that the shape of the dots varies depending on their surroundings. This is especially true along edges where the dots tend to elongate in the direction of the edge. This makes edges stand out much more clearly. Since edge definition is vital to perceived sharpness, the result is a major improvement in effective image quality.

Page printers generally cannot vary the shape of their smallest dot, and thus, at the lowest level, they cannot duplicate the effect of the photographic halftone. At a higher level—the cells made up of dots—page printers can vary the way the cell is filled in, but this approach operates at the expense of resolution.

One solution to this problem is to use a higher-resolution laser printer, so that the cells can be smaller and still represent a large number of discrete gray tones. This is effective but also expensive.

Smaller Dots

DP-Tek (Wichita, Kansas) has taken a more direct approach to the dot-shape problem. The company manufactures a Canon-engine controller called Laserport. Laserport combines a software package (for simulating the halftone process as explained previously) and a custom controller that actually varies the shape of the laser's dots.

DP-Tek claims that the Laserport controller can produce the equivalent of a 100-line screen print on a standard Canon print-engine laser printer, when driven by an IBM PC AT or comparable computer. (Figure A is a Laserport simulation of a 100-line screen, using as in-

put a digitized photograph provided by Adobe Systems.)

According to DP-Tek, the Laserport system is based on two elements: the controller's ability to produce dots in any needed shape and the company's rasterization process, which mathematically models the effects of screening a photograph.

DP-Tek originally developed the system because it had to put in a system to prepare a computerized Multiple Listing Service book. The books show real-estate agents the houses available for sale in a particular area and usually include a photograph of the house as well as the description. Because the books are updated frequently and issued in fairly small print runs, this was an ideal application for a laser printer—except for the photographs.

"The computer industry has always used standard graphics techniques," says Alan Frazier, DP-Tek's president. "We took the same approach at first, but we couldn't get a satisfactory quality level. Finally, we spent a lot of time looking at dots."

According to Frazier, one of the most important parts of developing the system was modeling what happens when a photograph is screened; in other words, when light is reflected through a variable-density screen from an image. The development work was done on AT-class computers in C and Pascal and later optimized and converted to assembly language for run-time packages. This was combined with a proprietary

controller that can vary the shape of dots.

The company is closemouthed about the details of the process. All Frazier will say about the way the controller works is that "in electronics, states are rarely purely on or off." Presumably, the controller varies the intensity of the printer's laser beam and/or the scan rate and drum-rotation rate to vary the shape of the dots. Figure B is an enlargement of a 300-dpi test pattern produced by Laserport, showing the system's ability to vary the dot size over a wide range.

The controller fits in the computer's case and works with the printer's resident controller. When the printer is printing text or graphics, the Laserport controller stays in the background. When it has to print a photograph, the Laserport controller handles it. The company claims that Laserport is transparent to the software that works with the laser printer.

The Laserport software includes drivers for the printers, modeling software to duplicate the effects of screening a photograph, and a set of high-level picture-printing commands. To print a picture, the user or the application program must tell Laserport where the picture is to go on the page and the name of the file containing the picture image.

The DP-Tek controller is sold to OEMs for incorporation into their systems. One customer is Chorus Data Systems of Merrimack, New Hampshire, which uses it with its Photobase graphics database.

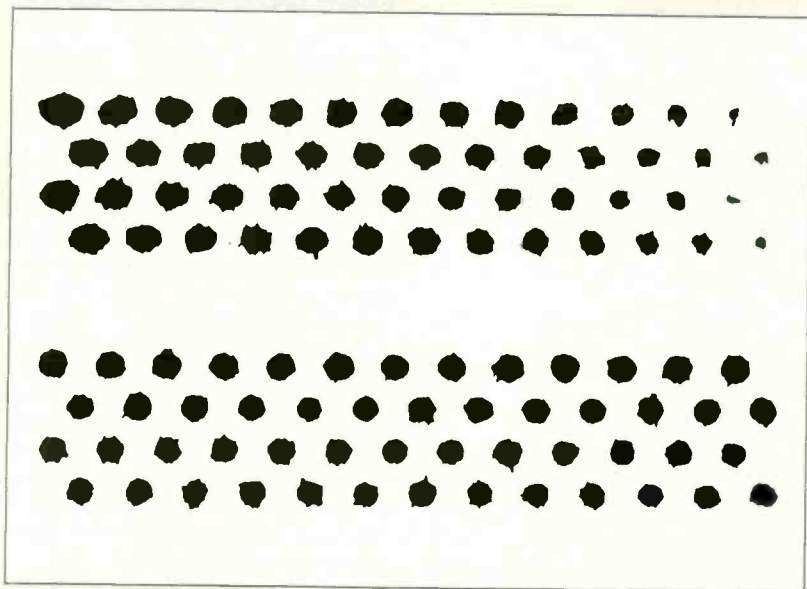

Figure B: An enlargement of a 300-dpi test pattern produced by Laserport, showing the system's ability to vary the dot size over a wide range.

LABELING SOFTWARE



For DOT MATRIX and Laser Printers

(Epson/IBM/Okidata/LaserJet)

- Labels for shelves, bins, inventory
- Text readable up to 50 ft.
- Bar Codes: 1 2 of 5, UPC/EAN MIL-STD, AIAG, Code 39
- Any size label • Flexible format
- Color options • Reversals • Fast
- File input • Menu driven • \$279
- Other bar code programs from \$49.

30 Day Money Back Guarantee!

WORTHINGTON

DATA SOLUTIONS

417-A Ingalls Street
Santa Cruz, California 95060
408/458-9938

Bar Code Readers for PC, XT, AT, PS/2



FS-232 and PS/2 model \$399
FC/XT/AT Internal/External ... \$385

- Rugged Metal Pen
- Reads 1 2 of 5, UPC/EAN Codabar, Code 39, etc.
- Attaches as 2nd Keyboard
- No software needed to add bar code reading to your system

30 Day Money Back Guarantee!

WORTHINGTON

DATA SOLUTIONS

417-A Ingalls Street,
Santa Cruz, California 95060
408/458-9938

Page Printer Typography

Laser printers are producing a revolution in typography. Type designers are adapting existing type styles to laser printers and designing new type styles to capitalize on the strengths of image printers and minimize their weaknesses.

The first mechanical composing machines, such as the Linotype, provoked a similar revolution when they appeared in the 19th century. The rigid mechanical spacing of the letters and the limited number of characters available in typesetter magazines forced designers to modify their type families. For example, italic fonts tended to become wider to match the spacing of regular fonts.

Phototypesetting precipitated another, smaller revolution in the 1950s. Rather than handcrafting each font in its own point size, typographers could design a single font and then use optics to produce a range of smaller and larger fonts. In some cases, the substitution of optics for hand design has resulted in a lowering of typographic quality.

The onset of digital type in the 1970s and 1980s has brought with it the promise of a return to the high art of typography. Having characters stored digitally brings all the power of CAD to the hands of the type designer. Page printers have brought the world of digital type to the personal computer desktop.

Typefaces and Fonts

Type is classified according to families. A family is a group of alphabets that are stylistically related. Within each family are several typefaces—alphabets sharing the same characteristics. Times Roman, Times Roman Bold, and Times Roman Italic are all members of the same type family. Typefaces are examples of a typeface in a particular type size. For instance, 24-point Times Roman Bold is a font, but Times Roman Bold is a face, a member of the Times Roman family. What computer people commonly call a typefont on a laser printer is really a typeface, since it comes in several different sizes.

The distinction between typeface and typefont is important because there is more to the different fonts in a face than enlarging and reducing the type. This is especially true with laser printers.

Low-Resolution Typography

A type designer working for laser printers has two interrelated problems. Figure C illustrates them.

The first one is that some faces don't work well at 300 dpi. For instance, a face with slight angles in its long strokes will cause trouble. The classic example is Optima, a face with gently slanting verticals. At 300 dpi in common book sizes, this produces a jarring break in long verticals, such as the stem of a *d* or an *l*. Italics from many families give designers trouble for the same reason.

The lower resolution can interfere with subtle features of typefaces. Garamond, a common book face, has cups at the top and bottom of many strokes. At 300 dpi, those cups are hard to reproduce in common font sizes.

The second problem is that, even in fonts that are adaptable to laser printers, the coarser resolution requires adjusting the letter shapes. For example, in many faces, the points of the *w* and *v* extend slightly below the baseline. At 2000 dpi, this looks elegant. At 300 dpi, the extension becomes crude and jarring.

A related consideration is font size. Relative letter spacing and weight (i.e., thickness of strokes) tend to change with the size of the font. Details that cannot be reproduced in small sizes are important in larger sizes; without them, the type looks wrong. Similarly, spacing that is appropriate for small sizes is often too loose in larger sizes.

This is nothing new. Type designers have always had to adapt fonts to the method of typesetting. But today's bit-image printers require more adaptation than previous innovations.

The correct, but not universally practiced, process of adapting a typeface to a laser printer starts with an idealized version of the face at very high resolution. This is as close to the original type design as possible, without any compromises for reproduction or resolution. Typically, before a type foundry begins adapting a typeface, a type designer must "clean up" the letterforms to correct for adaptations that were made for the sake of other typesetting processes.

Once the idealized face is in hand, the

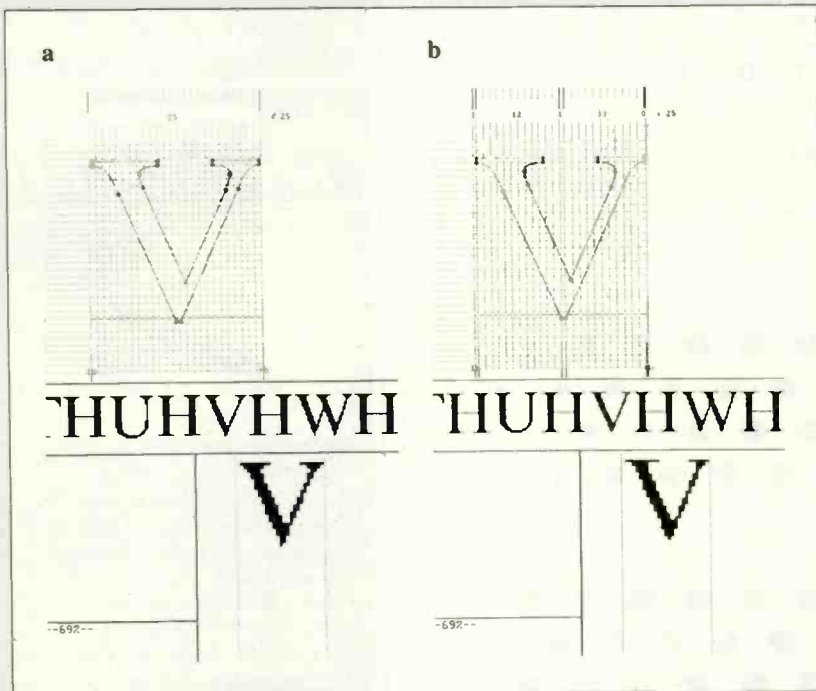

Figure C: Examples of typographic designs that are hard to duplicate on a 300-dpi page printer: (a) Before optimization: Note the uneven base-alignment of U, V, and W, caused by the slight descent of the curved and pointed bottoms of the characters. (b) After optimization: Bitstream's Fontware corrects for the variations by moving the outlines. These corrections will be made automatically until the point size is large enough to allow the resolution to be aesthetically displayed. (Figures C, D, and E are courtesy of Bitstream Inc.)

designers can begin adapting the face for different fonts.

A laser printer complicates this process because the resolution is so low. Information is lost when letters are reduced without any increase in resolution. For instance, a serif might disappear in the smaller typefaces, or a thin stroke may become exaggerated. As a result, type design for laser printers is in part a matter of *trompe l'oeil*. The eye must be fooled into believing features are present that actually aren't. The question facing the type designer is: Which information can be lost without distorting the letter too much? In one case, it might be better to compress a letter. In another, the stroke might be widened or a serif might be omitted.

One common adjustment is to increase or decrease the width of the strokes (vertical lines) so they coincide with a pixel column. Curves are less of a problem because the pixels of a curved line naturally fall on different scan lines, and the roughness can be made to average out. The extreme points of curves must coincide with pixel columns or they will become flat or pointed.

If you examine an enlargement of a laser-printed font, you will often find dots that don't seem to belong. An *r* might have a dot that appears too high in the curved stroke, or a *d* might have a dot almost floating inside the enclosed space. Actually, these "excess" dots are carefully placed to add weight or thickness at critical points and trick the reader's eye into seeing elements or details that are not there (see figures D and E).

The scaling is typically done algorithmically, at least in part. Type foundries usually have proprietary algorithms to change letter shapes as they enlarge and reduce their basic designs.

Once the face has been enlarged or reduced, a type designer usually optimizes it to make the font look as good as possible. This can involve not just resolution and size; it can also depend on the nature of the printer that will output the type. For instance, not all bit-image printing engines have the same ability to reproduce thin lines. The amount of optimization that is done depends on how well the algorithm represents the face in the new font and how much money the customer is willing to spend to get it right.

Adobe's PostScript PDL and Bitstream's Fontware system include algorithms for sizing faces effectively.

Bitstream has automated much of the design process with a program. Originally written in LISP on a Symbolics LISP machine, it is an expert system that

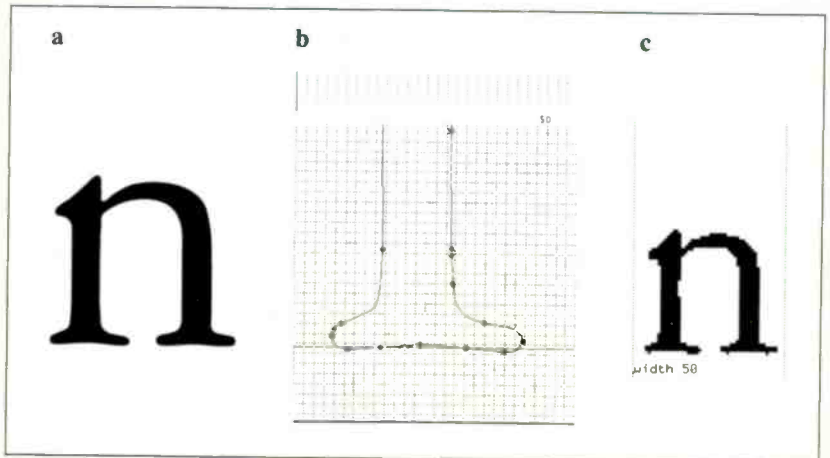

Figure D: Some type styles are not representable at resolutions below 800 dpi. The lowercase *n* (detail a) from Garamond #3 has wavering strokes and serif features that cannot be fit to conform to the grid (detail b). To get the effect of a finely wrought typeface using 300 dpi, designers often trick the eye by adding dots where they don't belong (detail c).

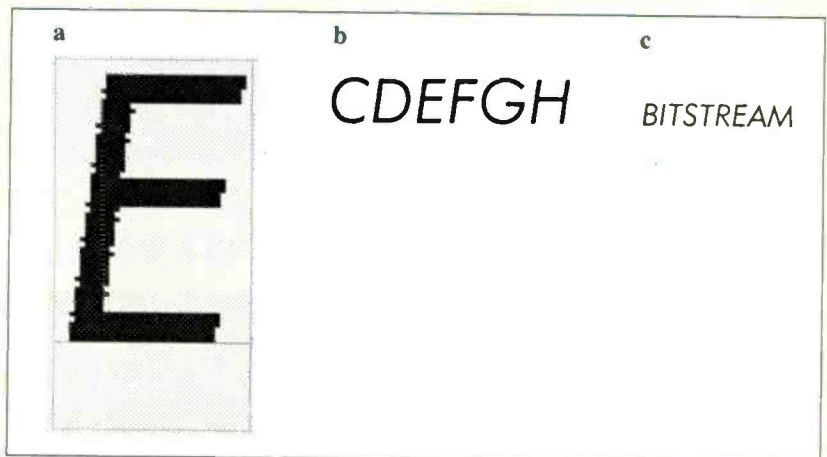

Figure E: Characteristics of some type styles are representable with manual corrections by designers working directly with the output technology. The uppercase *E* of Futura is enlarged at 12 times actual size (detail a) to show the serrated edge of the sloped vertical. At twice actual size (detail b), the serrations are still visible; but at actual size (detail c), the letters appear smooth and consistent.

chooses the best adjustments when scaling a face based on the rules used by Bitstream's type designers. Bitstream offers Fontware to OEMs so they can scale and fine-tune faces for their equipment themselves. The company plans to offer a run-time package to do the scaling on the laser-printer controller or the computer driving it. Hardware and software OEMs will be able to adapt the package to their equipment or software to give their users the same kind of control over their fonts. If a user needs a 22-point font, he or she can get something optimized for 22 points, not something designed for 24 points and scaled down.

Despite the problems involved in adapting faces to bit-image printers, there is only limited interest in designing faces, especially for 300-dpi printers.

Matthew Carter, vice president of design at Bitstream, is adamant that good type is good type; it doesn't change over the centuries. Garamond, a very popular face today, was designed about 400 years ago. It is a mistake to discard one face and design a new one just to accommodate the limitations of a new technology, Carter claims, because the technology will have improved enough to handle the standard face before the new face catches on.

Canon introduces **MORE.**

More easy-to-use features.
More advanced technology.
More productivity.



LBP-8II

Canon
LASER BEAM PRINTER

Canon U.S.A., Inc., Printer Division
One Canon Plaza, Lake Success, NY 11042

© 1987 Canon U.S.A., Inc.

No one kind of page printer is going to give users everything they want. There are too many basic conflicts and trade-offs.

printer. The particles seep into other parts of the printer. All these effects get worse as the toner particles get smaller.

The traditional solution is to use a wet toner in which the particles are suspended in a liquid. This method is used by high-resolution electrostatic printers like laser phototypesetters, but it is messy and adds complications of its own. New toner formulations and better toner-manufacturing processes are another possible approach.

The paper becomes a factor as resolution increases. One of the reasons laser phototypesetters achieve such high resolution is that their output is printed on very glossy stock. The smooth surface makes fine detail possible. But the quality of paper supplied to most office page printers isn't nearly as smooth; thus, the page printer's output isn't as good at comparable resolutions. Apart from the cost of ultrasmooth paper, the paper-handling mechanisms used in desktop page printers depend on the surface roughness of the paper to get a grip. Paper on very smooth stock requires different, more complicated methods, such as vacuum gripping.

As resolution increases, the electronic components of the printer become more expensive. Doubling the resolution to 600 dpi from 300 dpi means quadrupling the amount of RAM needed to store a page image—to 5 megabytes from 1.25 megabytes (unless the controller design is changed; see the article entitled "Designing a High-Speed Page Printer Controller" by Phil Ellison on page 225). Furthermore, the controller must either work twice as fast to lay down twice as many dots per scan line in the same time or slow down the laser beam, increasing the time required to print a page. While the electronics costs don't increase in proportion to the mechanical costs, the increases are significant.

Intrinsically, there is no reason a desktop page printer cannot match the resolution of phototypesetters—if the buyer is willing to pay the price. For example, Varityper now makes a small 600-dpi laser printer that costs about \$18,000.

PERMA POWER FIGHTS SURGES TWO WAYS...

OR WE PULL THE PLUG

Perma Power Surge Suppressors give you peace of mind, knowing that your computer is protected against power line surges and against suppression element failure.

PROTECTION FROM POWER LINE SURGES

Our unique 2-stage circuit uses heavy-duty metal oxide varistors to protect you against high-voltage lightning-induced surges, and high-speed semiconductor devices to protect against frequent fast surges. Only this kind of hybrid circuit can provide the necessary high power dissipation while still providing fast response time and low let-through voltage.

PROTECTION EVEN IF WORN OR BURNED OUT

Any surge suppressor can wear or burn out. With Perma Power you can relax! Power to your system is stopped... as completely as if the plug was disconnected. Other surge suppressors may use a light or buzzer "warning," while they continue to let raw, unprotected power feed directly into the computer. Only with Perma Power's patented Automatic Shutdown* feature is your equipment kept safe from damaging raw power.

Ask for Perma Power Extended Life Surge Suppressors, in 2, 4, or 6 outlets and Power Control Center models to insure your computer is being protected. At office, computer or electronics dealers nationwide.



*Patent #4,578,579

PERMA POWER
Electronics Inc.

5601 West Howard Avenue • Chicago, Illinois 60648
Telephone (312) 647-9414

Inquiry 222 for End-Users.
Inquiry 223 for DEALERS ONLY.

PAGE PRINTERS

Some phototypesetting machines are basically specialized laser printers, but they are even more expensive.

One factor holding back the development of high-resolution personal desktop page printers is that the manufacturers aren't sure that enough users are willing to pay the price. So far, the small page printer market has been highly price-sensitive, and the makers aren't sure most users will pay for higher resolution. Vari-typer's printer, for instance, is aimed at the typesetting market.

The Coming Printers

No one kind of page printer is going to give users everything they want. There are too many basic conflicts and trade-offs. Instead, you will probably see a range of desktop page printers with different mixes of price and features.

At the low end will be inexpensive 300-dpi printers with print speeds of 5 ppm or less and street prices between \$500 and \$1000. These printers will rely on the computer's processor and memory for control. Due to memory constraints, they will probably not be able to print full-page graphics and will not use a page-description language (PDL). They will probably be limited to 8½- by 11-inch paper and might handle only certain weights of paper. You might see the first of these by the end of the year, although the very inexpensive examples are probably two years off.

The next group of printers will offer higher print speeds and more features for a higher price. They will include a PDL, full-page graphics, more flexible paper-handling, and a variety of bells and whistles. These printers will probably start at about \$1200 and run up to \$5000 or more, depending on features. These printers are essentially refined versions of today's page printers. In that sense, they are already available.

Above that will be the high-resolution page printers. Except for their 600-dpi resolution, they will be much like the preceding group of printers. Prices for high-resolution printers will probably start at around \$5000. It will be at least a year, more likely two, before these desktop high-resolution page printers appear.

Finally, there will be desktop color page printers (see the article entitled "Color Printing" by Naomi M. Luft on page 163). These will probably come in at around \$10,000 and won't be available for at least two years.

One thing is certain. Users want fast, quiet, high-resolution printing. That being the case, page printers of all sorts are going to proliferate for the rest of the decade. ■

Canon introduces **LESS.**

- Less hassle.
- Less maintenance.
- Less bulk on your desk.
- Best of all, less cost.



LBP-8II

Canon
LASER BEAM PRINTER

Printouts that stand out.

Canon Enjoy easy extended payments with the Canon Credit Card. Ask for details at participating Canon dealers and retailers. Available only in US.

For more information, call 1-800-453-3307. In Utah, 1-800-662-2500.

It copies 5¼ and 3½ diskettes all by itself.

Just load your diskettes, press one button, and walk away. The Victory Auto-loader automatically copies diskettes operating stand-alone or attached to an IBM/PC® or Mountain® compatible system.

Bulk cannisters allow fast, easy loading and unloading. Switching drives takes less than five minutes.

Copy Different Formats, Flawlessly. Our Auto-Format-Analysis™ feature lets you copy different formats, including PS 2*. The system tests for quality and accuracy, sorting disks into one of two output cannisters.

No User-Required Adjustments. The Autoloader's self-calibration and simple diagnostics for checking drive alignment allow you to maintain the system without outside service.

Call 1-800-421-0103. And ask about the Victory family of affordable duplication systems—with serialization, copy protection and custom label printing.

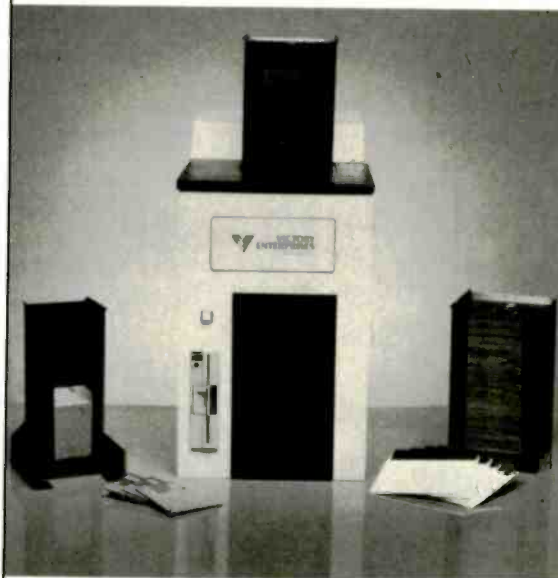

VICTORY ENTERPRISES

Technology, Inc.
8910 Research Blvd., B2
Austin, Texas 78758
512-450-0801

*IBM PC and PS/2 are trademarks of International Business Machines Corporation. Mountain is a registered trademark of Mountain Computer, Inc.

©1987 Victory Enterprises Technology, Inc.

SEE US AT PC EXPO BOOTH #2720

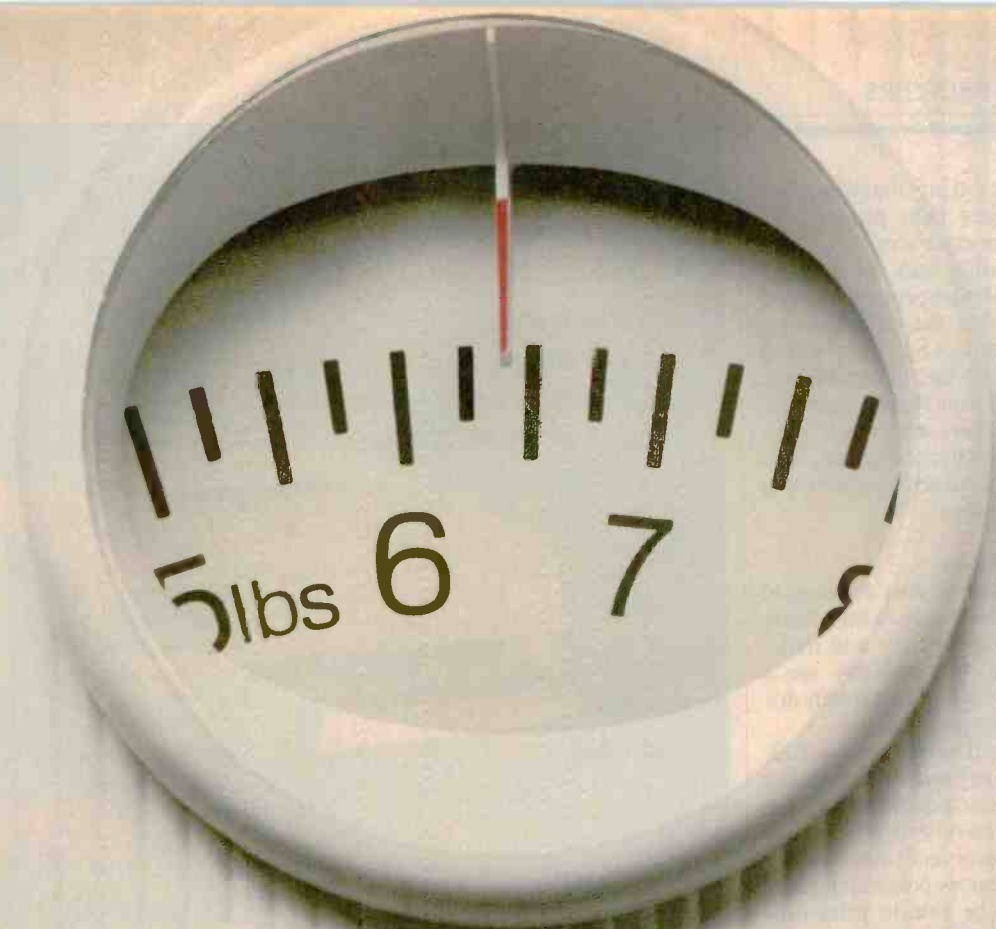

No Other Portable PC Can Make This Statement.

At 6.4 pounds, the new T1000 is the lightest portable PC in the world.

It's a good ten pounds lighter than some "portables." And you know how it feels to carry around ten extra pounds.

Yet within its diminutive footprint (it's about a foot wide and not even that deep) lies all the power of a desktop PC.

Included are 512KB of RAM and a built-in 720KB 3½" floppy drive, plus MS-DOS® 2.11 in ROM.

It comes with a new supertwist screen that's adjustable a full 180°, and folds flat when you want to add a CRT.

The IBM®-compatible T1000 offers you some very intelligent options. Like a numeric key pad and a 1200 bps Hayes®-

compatible internal modem. Or an expansion card that will improve its memory by another 768KB.

All in all, it's the perfect way to go to work without going to work. Or to get home early, even when you'll be working late.

Call 1-800-457-7777 for the Toshiba computer and printer dealer nearest you. And see how it feels to pick up the most portable portable in the world. Nothing is as easy to take.

Except, maybe, its price.

MS-DOS is a registered trademark of Microsoft Corporation. Hayes is a registered trademark of Hayes Corporation. IBM is a registered trademark of International Business Machines Corporation.



In Touch with Tomorrow
TOSHIBA

Toshiba America Inc. Information Systems Division

Print Quality

The factors influencing print quality and ways to measure it

Lars Jansson

WHAT IS GOOD print quality? The easy answer is a subjective one: Good print quality is whatever most people consider it to be. However, for a printer manufacturer, that answer is not good enough.

Over the past year, engineers at Facit have been working on a set of objective definitions for print quality. We have also developed a measurement system that rates a print sample over a wide range of performance values relating to print quality. The ultimate goal is to rate printer technologies, as well as commercial printers, on the basis of print quality without relying on subjective, variable human judgments.

From a technical point of view, perfect print quality entails the ability to put a message at an exact position on a piece of paper without distortion. The message can be a complete image; it is then called graphics. You can divide such an image into graphics primitives—line, arc, and dot. Alternatively, a message can consist of text, which can be further broken down into text primitives—alphanumeric characters. The alphanumeric primitives are far more complex than the graphics primitives; each letter or number is a graphics image in its own right.

In any system that does not produce fully formed characters, the symbols are built up from dots. (This includes dot-matrix-impact, thermal, laser, ink-jet, and similar printers.) Thus, we start with some fundamental questions about dots. What are the properties of a dot? What are the properties of a system for putting dots on paper? And what are the properties of a symbol composed of dots? An-

swering these questions gives us a good start on defining and measuring print quality.

Design Considerations

A dot has size, shape (normally round), and color or gray level (in an ideal black-and-white system, a dot is black or it doesn't exist at all). When we transfer a dot to paper, its size changes and its shape is no longer what it was supposed to be—distortion enters the picture. But before printing, and from a design standpoint, size and shape are important parameters.

When we want to place a dot on paper, the first question is: On what positions horizontally and vertically is it possible to put a dot? In other terms, what position-grid or matrix do we have? The next question is: How close to one dot can we place another? Most printers cannot actually use horizontally adjacent grid positions due to compromises between speed and resolution.

For example, a typical character matrix in a 9-pin dot-matrix printer has 12 horizontal grid positions in each $\frac{1}{10}$ inch. But what is the actual resolution available for character generation? The last three of the positions make up the intercharacter spacing; therefore, the character matrix is actually 9 by 9. But if we place a dot on the first position, that pin typically cannot use the second position because the electromechanical system takes time to stabilize before it can fire again. Thus, the closest allowable spacing, or the horizontal resolving power, for dots on a line is $\frac{3}{12}$ inch, not $\frac{1}{12}$ inch as the character matrix might suggest.

In the vertical dimension, the resolution is the same as the vertical spacing of pins on the print head. Improving the resolution beyond these design limitations requires multipass techniques: After the first print pass, the paper or the print head is offset by a small amount horizontally or vertically and prints the line again.

Next, consider the readability of dots, lines, and arcs. What happens when we place a number of dots in line? How close do they have to be to generate a good line and not just dot, dot, dot?

Figure 1a shows that a 30 percent overlap with regard to diameter and grid position gives a decent line. But is that the whole story? If the dots are square or rectangular, which is common for thermal-transfer techniques, overlap is not necessary—at least not for horizontal and vertical lines.

Diagonal lines present another problem, shown in figure 1b. This figure shows that dot overlap alone does not give the complete picture. Figure 2 illustrates a more refined measurement, the *blank-area factor*.

Mathematically, the blank-area factor is the ratio of the blank (unprinted) area to the total area of the ideal line. In the case of circular dots printing a straight line, it

continued

Lars Jansson is a member of the strategy and development staff at the head office of Facit, a Swedish manufacturer of computer peripherals. He can be contacted at Facit AB, S-17291 Sundbyberg, Sweden.

is sufficient to calculate one-quarter of the area over a span of two overlapping dots:

$$\begin{aligned} \frac{A}{4} &= \int_0^{S/2} [f(x) - g(x)] dx \\ &= \int_0^{S/2} \left[\frac{D}{2} - \sqrt{\left(\frac{D}{2}\right)^2 - x^2} \right] dx \\ &= \frac{SD}{4} - \left[\frac{SD}{8} \sqrt{1 - \left(\frac{S}{D}\right)^2} \right. \\ &\quad \left. + \frac{D^2}{8} \arcsin \frac{S}{D} \right] \end{aligned}$$

$$A = SD - \frac{1}{2} \left[SD \sqrt{1 - \left(\frac{S}{D}\right)^2} + D^2 \arcsin \frac{S}{D} \right]$$

where D = the print wire diameter, S = the distance between print positions (center to center), $f(x)$ = the shape of the ideal line to be printed, and $g(x)$ = the shape of the print wire.

The blank-area factor is given by

$$\frac{A}{SD} = 1 - \frac{1}{2} \left[\sqrt{1 - \left(\frac{S}{D}\right)^2} + \frac{D}{S} \arcsin \frac{S}{D} \right]$$

Generally, the greater the overlap, the smaller the blank-area factor will be. But, when we use the above equation for varying degrees of overlap, we discover a point of diminishing returns somewhere between 10 percent and 30 percent, at least when round print wires are used (see table 1).

Of course, printer symbols don't con-

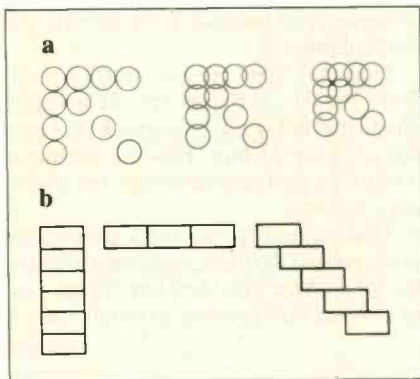

Figure 1: (a) Effects of varying degrees of dot overlap on the clarity of lines with circular dots. (b) Rectangular dots require no overlap for horizontal vertical lines.

sist just of straight lines. Arcs—circles or partial circles—are crucial in the design of most typefaces. Unfortunately, in the case of arcs, minimizing the blank-area factor requires a higher degree of dot overlap. Furthermore, these arcs demand as much from the vertical resolution as from the horizontal, while in most matrix printers, the vertical resolution is often just half as good as the horizontal. The solution to this design challenge tends to be expensive.

Minimizing the Blank-Area Factor

If we can achieve good print quality by having a small blank-area factor, how do we then get one? One answer is obvious—a dense matrix and small dots. We find this in laser printers with a resolution of 300 by 300 dots per inch and a dot size of about 0.1 millimeter. However, impact-matrix printers have a limit to the dot size: pins of 0.1-mm diameter will pass right through the ribbon without touching. The minimum practical dot size seems to be 0.2 mm, which we find in 24-pin print heads.

A small dot causes a new problem: Reproducing the vertical lines or stems of most characters requires printing at least two adjacent dots, which slows down printing and also affects the blank-area factor.

With this in mind, we must look for a different dot shape, one that gives a better blank-area factor and does not require two dots to make a vertical line. Figure 3a shows the result (enlarged and idealized) of using a semielliptical dot that is 0.2 mm vertical and 0.34 mm horizontal. If a print head can accommodate elliptical pins, this approach looks promising.

Typographic Ideals

What is the property of a symbol?

If we restrict ourselves to alphanumerics

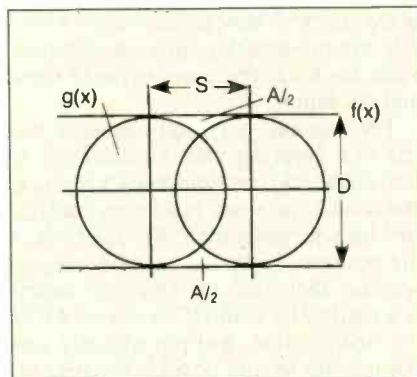

Figure 2: The blank area A is a function of dot diameter D , overlap S , the shape of the line $f(x)$, and the shape of the dot $g(x)$.

and allow full freedom for aesthetic considerations, we can avail ourselves of 500 years' worth of typesetting and font design. So why reinvent the wheel by doing our own typefaces? Unfortunately, we do not have full freedom, particularly not in matrix printers. Given the limitations of a particular matrix, it can be extremely difficult to adapt a set of characters that was originally defined in terms of continuous lines. It is often much easier and more successful to design an attractive set of characters specifically for one printer's limitations. So we're back to fundamentals of typeface design.

What then is the most important property of a symbol? If we can't read it, it doesn't matter how pleasing it is to the eye, so readability is number one. What is readability, and what distinguishes one character from the other?

Figure 3b tells you that the upper part of lowercase letters gives much more readability information than the lower part. (Try reading each half with the other half blocked from view.) In particular, the intersection between stem and body gives a lot of information—distinguishing between b and d, for example.

Most of the characters in the roman alphabet consist of one or more lines created without lifting the pen from the paper. Some characters also have diacritical marks, but, even for those characters, the major portion is a continuous line. What distinguishes one line from another is the varying line width and, in some cases, the serifs used at the end of the line.

We have a dilemma. Typographic art requires a fine grid, small dots, and, very often, thick lines. On the other hand, print speed requires either a coarse grid or, in a fine grid, the allowance to skip over one or several positions after printing a dot. The cost of technology limits the position accuracy, dot frequency, and dot size. It is not possible to satisfy all these quality and speed requirements at the same time. Already, at the design stage, we have to make compromises.

After designing the ideal grid and selecting a dot size, dot shape, and character shape, we can print symbols on paper. But the result on paper is far from what we envisioned. Misalignment and skewing appear, with respect to lines and even with respect to character cells. The characters themselves do not look as designed. Ink appears where it is not supposed to be and none, or very little, where it is supposed to be. Why is this so, and how do we measure the departure from the ideal?

Measurement System

To objectively and efficiently perform all the measurements and their related calcu-

continued

Reliable, Cost Effective Solutions for Computerization

A Motherboard and 4 Expansion Cards in the Space of a Half-Height 5-1/4" Disk Drive!

from **\$329**
(Qty 100, \$252)

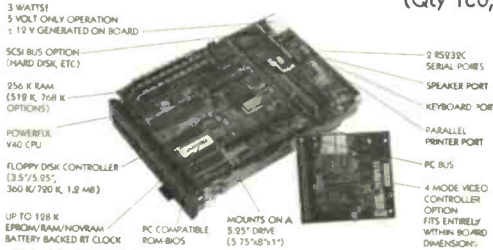

Little Board™/PC
World's smallest PC — and CMOS too!

\$329
(Qty 100, \$252)



Little Board™/186
High performance single
board MS-DOS system.

\$159
(Qty 100, \$124)



Little Board™
World's least expensive
single board system.

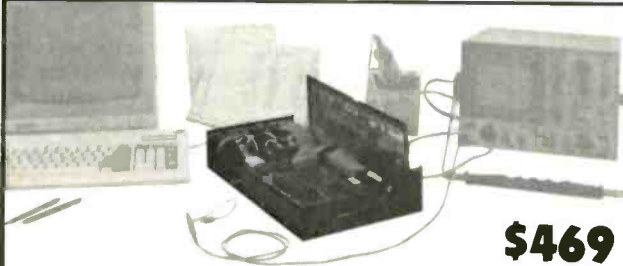

Development Chassis/PC™
"Known Good" PC bus project development environment
for Little Board/PC (not included).

\$469

\$99



Project Board/186™
Prototype adapter
for 80186 based projects
and products.

\$89



Project Board/80™
Prototype adapter
for 8080 based projects
and products.

Z80™
Z801G

\$159

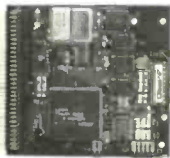

CMOS Video Controller
4-mode CMOS video
controller for Little
Board/PC.

from **\$179**



SCSI Memory Controller
SCSI controller for fixed and
removable volatile and non-
volatile semiconductor memory.

from **\$149**



Expansion/186™
Multi-function expansion for
Little Board/186. I/O, Serial,
RAM, and Math Options.

\$129



SCSI/IOP™
STD bus I/O expansion
adapter for any SCSI host
system.

from **\$495**



Bookshelf™
System Modules

- PC compatible Little Board/PC systems.
- Single and Multi-User Little Board/186 systems.
- Little Board/Plus CP/M systems.
- SCSI disk and tape expansion modules.
- Floppy drive expansion modules.

\$395



Concurrent PC-DOS™ (MS-DOS)
Multi-user, multi-tasking oper-
ating system for Little Board/186
supports up to four users.

\$99

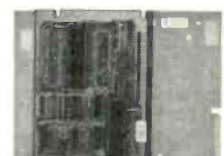

SCSI Z80 Host Adapter
SCSI host adapter for any
Z80 system.
Plugs into Z80 socket.

Distributors • Argentina: Factorial, S.A. 41-0018 • Australia: Current Solutions (03) 227-5959 • Brazil: Computadores Compuleader (41) 262-4866 • Canada: Tri-M (604) 438-0028
• Denmark: Danbit (03) 66 20 20 • Finland: Symmetric OY 358-0-585-322 • France: EgalPlus (1) 4502-180C • Germany, West: IST-Elektronik Vertriebs GmbH 089-611-6151 • Israel:
Alpha Terminals, Ltd. (03) 49-16-95 • Spain: Hardware & Software 204-2095 • Sweden: AB Akta (08) 54-20-20 • UK: Ambar Systems, Ltd. 0296 435511 • USA: Contact Ampro

AMPRO
COMPUTERS, INCORPORATED

67 East Evelyn Avenue • Post Office Box 390427, Mountain View, CA 94039 • (415) 932-0230 • TLX 4940302

CD-ROM IS HERE!

LOW PRICES

CD-ROM DRIVES

■ Panasonic SQ-D1 \$1095*
Half height - internal mount - high speed - industrial grade - Hi-Fi CD audio capabilities (with CDP Audio Software described below) - daisy chain capabilities - for IBM PC/XT/AT and full compatibles.

SPECIAL SEPTEMBER OFFER

Hitachi CDR-1503S \$799*
Full height - standalone - front auto load - Hi-Fi CD audio capabilities (with CDP Audio Software described below) - daisy chain capabilities - for IBM PC/XT/AT and full compatibles.

■ Hitachi CDR-2500 \$849*
Full height - internal mount - high speed - daisy chain capabilities - for IBM PC/XT/AT and full compatibles.

* Price includes interface board, connect cable and CD-RDM drive. Call for low prices on CD-ROM drives from all major manufacturers.

SOFTWARE +

■ Grolier—The Electronic Encyclopedia \$295
Contains 30,000 articles, full text of the 20-volume Academic American Encyclopedia, an educational tool the whole family can use. Easier to use and less than half the cost of the printed encyclopedia. Early buyers entitled to low cost annual updates.

■ Microsoft—Bookshelf \$295
The ultimate memory resident writing tool. Instant CD-ROM access to 10 major writing reference sources including Roget's Thesaurus, The American Heritage Dictionary, and Bartlett's Familiar Quotations. Includes Houghton Mifflin Spelling Checker and Usage Alert Software. Compatible with 14 leading word processors and most other programs including Microsoft Multiplan and Lotus 1 2 3.

■ CDP—Audio Software \$95
Software permits users to access Hi-Fi CD audio capabilities of Panasonic SQ-D1 and Hitachi CDR-1503s drives described above.

AUDIO SOFTWARE COMPETITION

The first 100 purchasers of the CDP-Audio Software are invited to customize the software to include programmable CD music capabilities, digital music volume and frequency displays, and sound synthesizing capabilities. The winning software package will be distributed to all purchasers of the CDP-Audio Software. The author of the software will be awarded \$1000 of CDP products and a royalty on all sales of the software.

■ PG-SIG—PC Software Sampler \$125
125 of PC-SIG's most popular public domain software programs for IBM PC's and compatibles. Includes word processors, spreadsheets, personal and business accounting packages and much more. PC-SIG's directory of 700 public domain programs included (\$12.95 value).

■ McGraw Hill—Science & Technical Reference Set \$300
Includes full text of the famed Concise Encyclopedia of Science and Technology (7,300 articles) and the Dictionary of Scientific and Technical Terms (9,500 terms and 115,500 definitions). Powerful search algorithms provide instant access to reference data.

+ Call for business and library CD-ROM software product pricing

STARTER PACKAGES

All drives will be discounted \$50 when purchased with software. Call for corporate discount information.

**TO ORDER CALL 800-MEGABYTE (634-2298)
IN NEW YORK STATE 212-996-6999
INQUIRES CALL 212-996-6999**

Policy: Shipping and handling extra. Personal and company checks require 3 weeks to clear. For faster delivery use your credit card (add 3% for MC and Visa, add 5% for AMEX) or send a cashier's check or bank money order. New York residents add 8.25% sales tax. All prices are U.S.A. prices and are subject to change and all items are subject to availability. Defective software will be replaced with the same item only. Hardware will be replaced or repaired within the terms and limits of the manufacturer's warranty. We cannot guarantee compatibility. All sales are final and returned shipments are subject to a restocking fee.

CDP

Compact Disc Products, Inc.
P.O. Box 1520 Wall Street
New York, NY 10268

PRINT QUALITY

lations, we use an image-processing system from the Swedish company Context-Vision (see figure 4).

First, we take a carefully planned print sample, enlarge it, and convert it into a digitized gray-scale image. Photo 1 shows an original and its digitized counterpart. Now that the print sample is in digital form, we have access to a powerful array of image-processing operations.

The first operation is to divide the image into meaningful regions—characters or dots, depending on what we're measuring. Briefly, the system uses a threshold level to sort out the pixels that belong to the background from the ones that belong to the character or dot. Photo 2, produced with the ContextVision system, is a histogram showing the frequency of intensity levels. Table 2 lists some of the results of the image analysis.

Position Deviation

One way to measure position deviation is simply to measure the distances between characters on a row of identical characters and calculate the variance. However, numerical cancellation tends to reduce the validity of the measure. A better way is to measure the deviation of each character from its ideal location, using as a

reference point the character's center of gravity, as shown in figure 5.

Position variance is defined as

$$v_x = \frac{1}{n-1} \sum_{i=1}^n (d_i - \bar{a})^2$$

$$= \frac{1}{n-1} \left[\sum_{i=1}^n d_i^2 - n\bar{a}^2 \right]$$

and the position deviation is

$$SV_x = \sqrt{v_x}$$

where d_i = the distance between a printed and an ideal character, n = the number of distances measured, and \bar{a} = the mean value of the distances d_i .

Edge Sharpness

Good printing should be crisp and clear; the edges of characters should be very well defined. Reality, once again, tells you that this is not the case. Under magnification, the edges appear as shown in photo 3.

One way to measure edge sharpness is to plot the darkness of a character as a function of distance across one of its component stems and then to measure the

continued

Table 1: At around 30 percent overlap, the blank-area factor becomes small enough, and further increases in overlap are not significant.

Overlap (%)	S/D	Blank-area factor
0	1.0	0.2146
10	0.9	0.1600
30	0.7	0.0891
50	0.5	0.0434

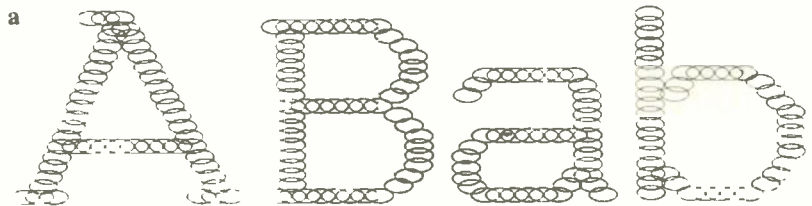

Figure 3: (a) Elliptical dots reduce the blank-area factor without as much overlap as circular dots. (b) The top part of roman letters conveys more information than the bottom; try reading each half with the other blocked from view.

The Magic.



The Facts.

The fact is, companies that use POSTSCRIPT® laser printers are creating some very exciting communications. Quite often, the word magic pops up.

Yet behind this exciting development in business communication, you'll find some hard facts worth serious consideration.

Fact. POSTSCRIPT is the page description language chosen by some of the best names in desktop publishing.

Fact. POSTSCRIPT gives you the option of printing from an IBM PC, Macintosh, or mini/mainframe.

Fact. You won't be tied to a single vendor so you can buy the printer that's best for your company's needs.

Fact. Since POSTSCRIPT is device independent, you can design a document, then professionally print it later at a higher resolution.

Fact. You can choose from hundreds of software programs that support POSTSCRIPT.

Fact. POSTSCRIPT lets you combine text, line art, and even digitized photographs on the same page.

Fact. If you don't ask for a printer equipped with POSTSCRIPT, you won't get the magic behind desktop publishing.

Now that you have the facts, just think what your company can do with the magic. For more facts, give us a call at 415-852-0271.



POSTSCRIPT from Adobe.
The magic behind desktop publishing.

The pages above were printed on a PostScript equipped printer
*PostScript printers include Agfa-Gevaert P400PS, Apollo Domain/Laser 26, Apple LaserWriter/LaserWriter Plus, Dataproducts L2R-2665, Diconix Dijit 1/PS, Digital Equipment Corp. PrintServer 40/Script Printer, ITT Gume ScriptEN, Laser Connection PS Jet, Linotype Linotronic 100/Linotronic 300, NBI Model 908, NEC SilentWriter LC-890, QMS-PS 800/800 Plus, QMS-PS 2400, QMS-PS 2700 CK, Sun Microsystems LaserWriter, Texas Instruments OmniLaser 2108/OmniLaser 2115
PostScript is a registered trademark of Adobe Systems Incorporated. Other brand names are trademarks or registered trademarks of their respective holders

width of the edge—the portion of the character where the intensity falls from 90 percent to 10 percent (see figure 6). This measurement is repeated along the perimeter and is normalized by dividing the sum by the number of samples.

Edge Roughness

Before a character—and, on a lower level, a dot—is printed, its edge is straight or slightly curved. In the printing process, this property is lost and edge roughness appears instead (see photo 4).

Edge roughness is thus defined as the distortion that comes from small local errors in the edge line; note that this attribute is distinct from the global shape deviations described below.

To measure roughness, we use the fact that the perimeter of a character with a rough edge is longer than the one of a character with a smooth edge. Using image processing, we smooth the perimeter and then compare the perimeters before and after smoothing. Roughness is thus defined as the ratio of the original perimeter to that of the averaged object.

Edge Orientation Variance

An interesting property of edge roughness is the variation of the orientation of roughness around the edge. By measuring the direction as well as the magnitude of roughness for every point around the perimeter, we can understand some of the reasons for the edge roughness. For example, depending on the roughness orientation, we may be able to deduce that a print wire is oscillating or out of alignment or that power distribution is uneven over the wire matrix. Our image-processing system includes a special operator that produces an image in which the brightness of each pixel corresponds to the confidence that an edge is present and the color corresponds to the direction of that edge (see photo 5).

Shape Deviation

A large global error in a character (e.g., a bent stem in the letter T) is defined as shape deviation. Shape deviation is measured over a set of, say, 100 duplicate characters by superimposing the characters on each other. You can measure the “fuzziness” of the edge by calculating the statistical variance between pixels located at the same place on the different characters and then summing these variances. (Note that the pixels I’m referring to exist inside the image-processing system and are much smaller than the print dots.)

Gray-Level Variance

The gray-level variance measures how uniform the blackness of the character is. Ideally, the gray-level variance should be zero, or at least very small. Gray-level variance is calculated as follows:

$$v = \frac{1}{n-1} \sum_{i=1}^n (x_i - \bar{x})^2$$

$$= \frac{1}{n-1} \left[\sum_{i=1}^n x_i^2 - n\bar{x}^2 \right]$$

where x_i = the gray level of each pixel in the character, n = the number of pixels in the character, and \bar{x} = the mean value of the gray level x_i .

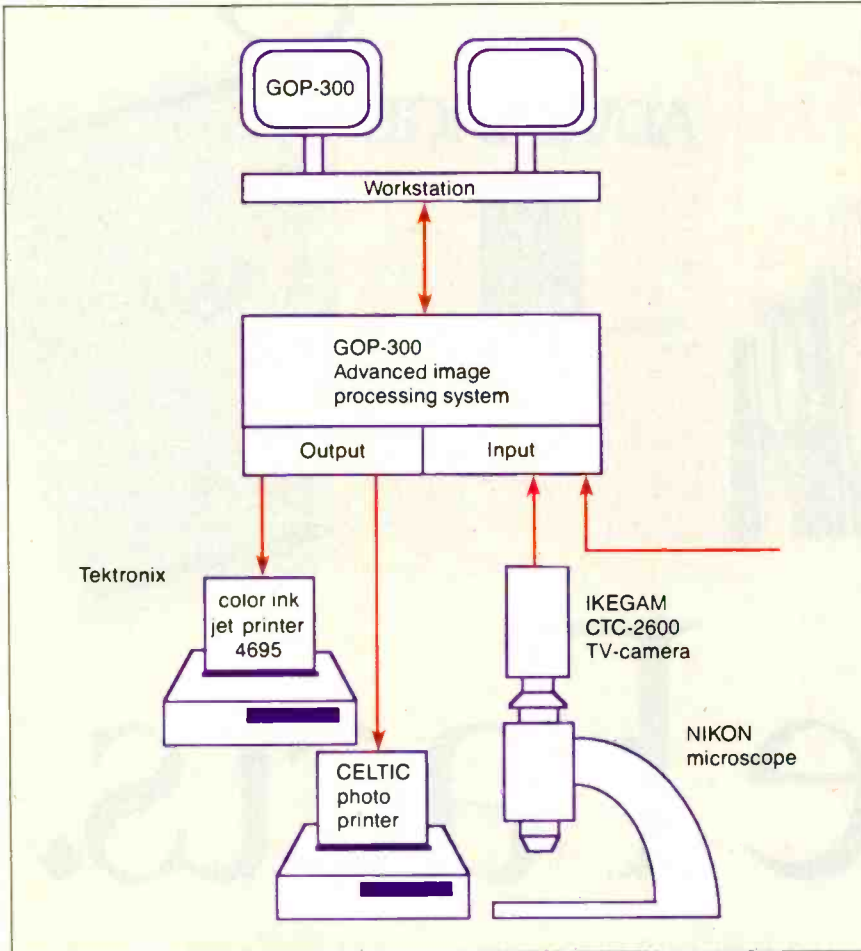

Figure 4: Schematic diagram of the ContextVision image-processing system Facit uses to make objective print-quality measurements.

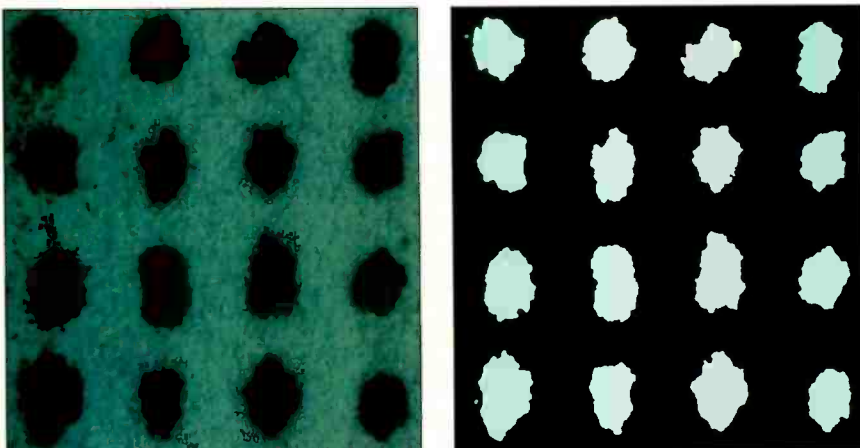

Photo 1: (a) The original printed test pattern and (b) its digitized counterpart (with colors reversed).

This measurement applies to entire pages as well as to characters. In the case of characters, we measure the gray level of each pixel and calculate the result. To get the gray level of a page, we perform the same calculation a second time, using

the mean value of the characters' gray level as measurement data.

Interpreting the Data

Now that we have an objective measurement tool for print quality, how do we ap-

ply it? Looking over the different attributes, it seems that we have been measuring badness rather than goodness of printing. Does this negative orientation let us make positive comparisons be-

continued

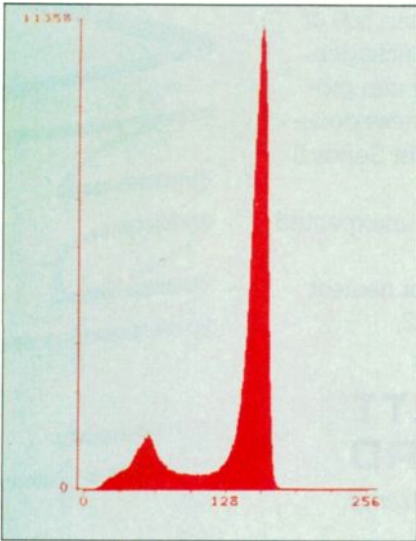

Photo 2: Histogram of the gray-scale image of photo 1.

Table 2: The statistical results from the image-processing analysis. (Roundness in the ContextVision system is the integration of the shortest distance to the edge per pixel for all pixels within the dot, for all dots within the sample. D_{max} is the length of the longest axis through the center of gravity for each dot in the sample. Angle is the angle of the longest axis.)

		arithmetic mean	standard deviation
Area	(mm ²)	0.091	0.0123
Mean diameter	(mm)	0.340	0.0229
Roundness	(CTX)	1.585	0.1427
Perimeter	(mm)	1.395	0.1307
D_{max}	(mm)	0.430	0.0466
Angle	(deg)	90	12.3
Satellites		4	
Measured objects		16	
Contrast (obj/bkn)		0.40	

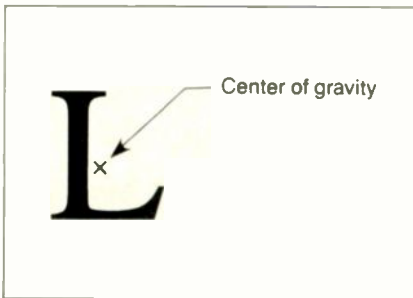

Figure 5: A character's "center of gravity" is used as a reference point in calculating position variance.

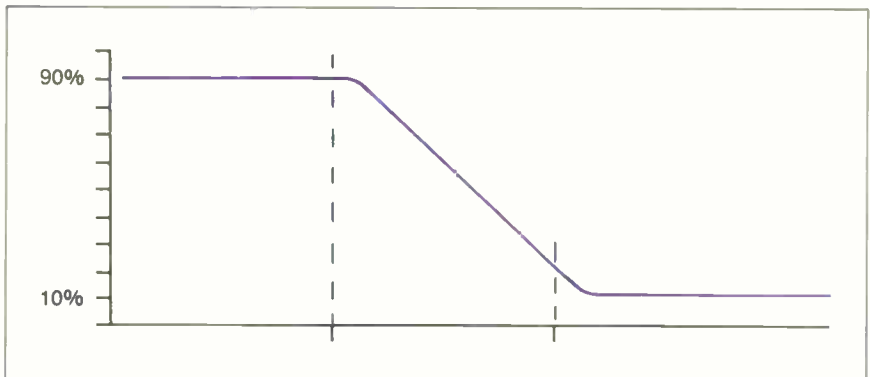

Figure 6: The gray level of a character is plotted as a function of distance. The area between 90 percent and 10 percent intensity corresponds to the fuzzy edge of the character. In sharp, clear printing, this region is minimized.

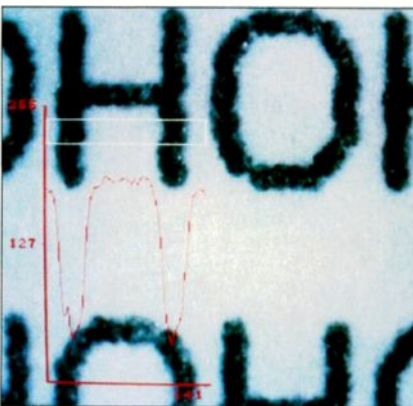

Photo 3: Edge sharpness is measured within the white border. The red graph shows the rate of fall off from black to white.



Photo 4: To measure edge roughness, we compare the perimeter of the original object to the perimeter of a smoothed version.

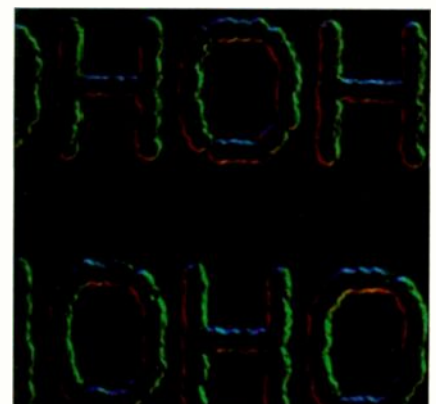

Photo 5: Different colors represent different orientations of edge roughness in this computer-enhanced representation.

What can you expect from the new LaserJet Series II Printer?

we never stop asking

What if...



Everything. Because the LaserJet Series II Printer from Hewlett-Packard is the product of experience. It's a second generation printer from the company with the world's largest installed base of laser printers.

Whatever your company's needs, the LaserJet Series II will deliver the performance you expect, at up to 8 pages/minute.

Take a simple memo like the Soup letter we created with Microsoft Word. As you can see, you can print in a variety of formats and type styles with our wide selection of LaserJet fonts.

Or you can create a sophisticated combination of text and graphics. With additional plug-in memory, you can also produce full-page 300 dpi graphics, like

our Nuts form shown below. To do this, we used HP's new ScanJet desktop scanner, Microsoft Windows and Pagemaker® from Aldus.

With support by more than 500 of the most popular software packages, the LaserJet Series II Printer can produce whatever type of business document you need. And LaserJet Series II works with all popular PCs.

In fact, only the price is unexpected — starting as low as \$2,595.*

For the authorized dealer nearest you, call us at 1 800 367-4772, Ext. 900A.

 **HEWLETT PACKARD**
Business Computing Systems

MicroSoft is a registered trademark of MicroSoft Corp. Pagemaker is a U.S. registered trademark of Aldus Corporation.
*Suggested U.S. list price. © 1987 Hewlett-Packard Co. PE12701

Inquiry 123

Soup

Canned Soup Council

Mr. J. C. Ryan, President
Flossmoor Soup Company
Flossmoor, Illinois 60422

August 1, 1987

Dear Mr. Ryan:

In an effort to help you stay competitive, we are publishing 5-year sales projections for two soup categories: canned and dry. Please keep these projections handy as they will aid you in your product planning over the coming years. Of special interest to you are the dry soup projections.

	CANNED	DRY
1987	\$6,700,000	\$1,100,000
1988	\$7,300,000	\$2,100,000
1989	\$8,400,000	\$2,600,000
1990	\$9,300,000	\$4,800,000
1991	\$9,900,000	\$7,300,000

As you can see, industry experts project that the gap between dry and canned soups will begin to close by 1990. They also believe mergers will follow.

Noodle Price Hike

Bad news this month comes from TNG (The Noodle Group). By year's end, they project the price of noodles to double — up to eighteen cents a barrel. How will this price hike affect you? A two-cent per can increase on all noodle soups you sell.

Recommended Reading: "Cup or Bowl?" This in-depth study discusses the habits of the American soup eater. Call and I'll send you a copy.

Sincerely,

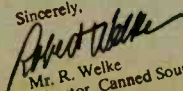

Mr. R. Welke
Director, Canned Soup Council

NUTS

Deluxe Assortment

Spring 1987



Peanut

A tasty, unique assortment from plantations in Africa and Southeast Asia. And, yes, from Georgia too!

Brazil Nut

Exclusively from South America, these Brazils are fat, hard-shelled and delicious. They'll be much in demand.



Hazelnut

Cakes, cookies, ice cream, chocolate, salads. They'll never taste better than with this delicious French variety.

Almond

They're popular and they're versatile. Available whole, sliced or chopped, they're equally at home in Mom's favorite recipes.



Pecan

Another great favorite in the bakery. And our own superb pecans will satisfy even the most discriminating Southern tastes.

Walnut

Blond English Walnuts are just one of the many varieties available in the best nutcracking tradition.



Chestnut

Superior varieties from our own plantations in Italy and France. All the best for more than seasonal consumption.



Pistachio

With an unusually subtle and delicate flavor, these perennial favorites will be perfect for either sweet or savory dishes.



What users perceive as bad print quality relates directly to certain measurable attributes: smearing (and its inverse, voids), shape, and dot density.

tween different print samples?

To make the leap from laboratory measurements to inferences about perceived quality, we must calibrate our measuring tool against the subjective opinions of a wide variety of users. In other words, we need to know the relationship between objective measurements like *position deviation*, *shape*, and *dot density*, and wine-tasting terms such as *crisp*, *clear*, and *pleasing*. To go one step further, can we use our objective measurements to define, once and for all, the various print-quality levels: draft, correspondence, near-letter quality, letter quality, and whatever we wish to call the next quality level?

At Facit, we have much more research to do on these issues, but preliminary work reveals some useful information.

What users perceive as bad print quality relates directly to certain measurable attributes: smearing (and its inverse, voids), shape, and dot density. A print sample's rating in these three areas seems to account for 80 percent of its subjective score, provided it is a normal sample without gross errors.

Smearing (ink where it is not supposed to be) and voids (no ink where it is supposed to be) correspond to our measurements of edge roughness and sharpness.

Shape attributes correspond to our measurements of the blank-area factor, position grid, and shape deviation.

Dot density relates to the tuning of the virtual and the actual grid, the blank-area factor, and the gray-level variance.

Once we have agreed on a correlation between our objective measurements and subjective judgments, we still are not done. Finding the reason for the flaws in a print sample—a design limitation of the printer, a faulty adjustment, poor quality or incorrectly matched ribbon, or unsuitable paper—is outside the scope of our tests but is important nonetheless.

We are continuing to work on the problem of measuring print quality, and we welcome comments and suggestions from users and from others involved in printer design. ■

A MESSAGE TO OUR SUBSCRIBERS

FROM TIME TO TIME WE MAKE THE BYTE SUBSCRIBER list available to other companies who wish to send our subscribers material about their products. We take great care to screen these companies, choosing only those who are reputable, and whose products, services, or information we feel would be of interest to you. Direct mail is an efficient medium for presenting the latest personal computer goods and services to our subscribers.

Many BYTE subscribers appreciate this controlled use of our mailing list, and look forward to finding information of interest to them in the mail. Used are our subscribers' names and addresses only (no other information we may have is ever given).

While we believe the distribution of this information is of benefit to our subscribers, we firmly respect the wishes of any subscriber who does not want to receive such promotional literature. Should you wish to restrict the use of your name, simply send your request to the following address.

BYTE MAGAZINE

ATTN: SUBSCRIBER SERVICE
P.O. Box 6821
PISCATAWAY, NJ 08854



MULTITASKING with TimeSlicer

Now, create multithreaded and real-time MS-DOS applications in C.

TimeSlicer is a linkable library of C functions to create multitasking and real-time programs at the application level rather than interfacing with the operating system.

- No limit to number of tasks that can be run concurrently.
- Tasks can be created, suspended or terminated at run-time.
- Highly efficient — 10,000 context switches/second; 80 micro seconds interrupt latency.
- Supports large and small memory models; preemptive and non-preemptive modes; waking up of tasks to optimize special event processing; and interrupt service routines written entirely in C.
- Extensive intertask communication capability.
- Optimizes processor usage transparently.
- Includes examples programs with source code.
- Compatible with Lattice C, Microsoft C, ADVANTAGE C++ and assembly language.



To order or obtain a complete technical specification sheet call:

1-800-847-7078

In NY: 914-332-1875

55 South Broadway Tarrytown, NY 10591

LIFEBOAT

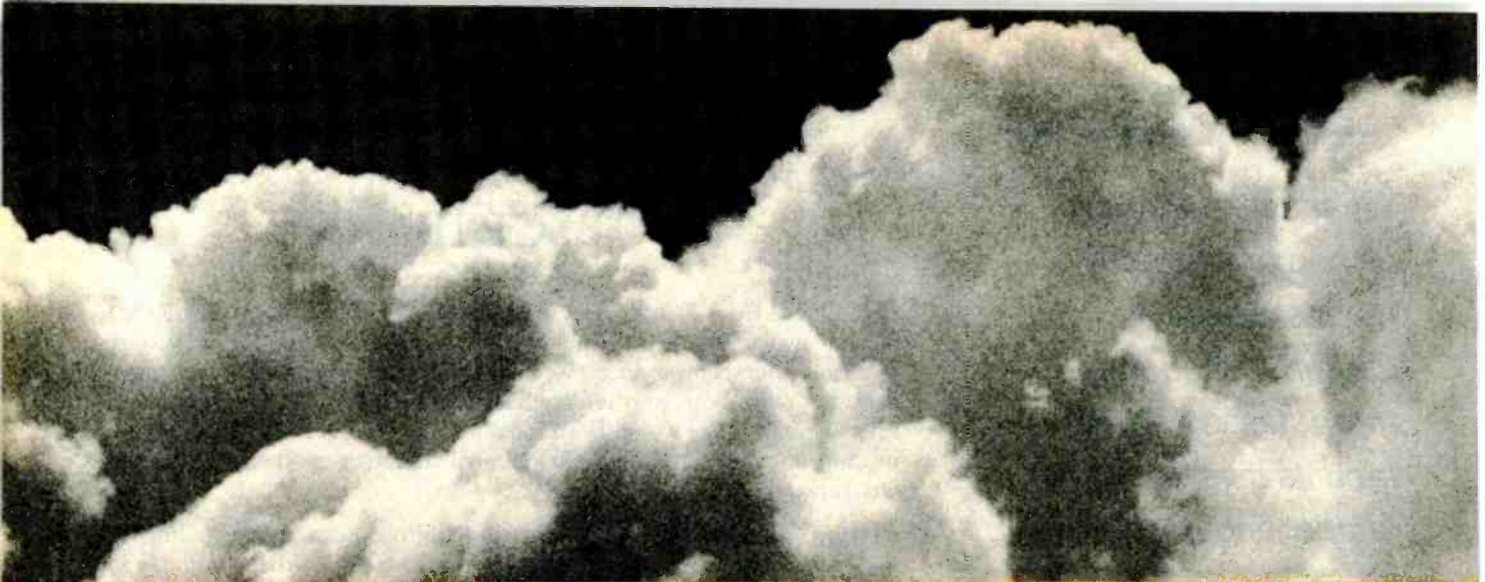

SOMETIMES, THE ACID TEST OF OUR MICROPROCESSOR DEVELOPMENT TOOLS IS UP IN THE AIR.

Two miles up, in the belly of a U2 jet, the U.S. Government is now tracking acid rain and radioactive particles with a just-developed device called an Upper Air Sampler.

But months earlier, with expensive development hardware on the blink, timely completion of the project was in real jeopardy.

Luckily, Avocet was called to the rescue. And within 48 hours we came through. With "the best software development tools" their design engineer had ever seen.

Not to mention, down-to-earth prices.

Let Avocet turn your PC or VAX into a powerful, integrated development system in 48 hours, even overnight.

Avocet can help you turn more good ideas into more real products in less time.

Just call us now and we'll get you up and running—with everything you need to turn your computer into a personal, professional development system.

All at a modest price. From a single source. Backed by the reassurance of a technical hotline. So friendly, knowledgeable support is always as close as your phone.

No wonder design engineers with no time to spare come to us first—and keep coming back smiling.

Any similarity to Intel, Hitachi or Motorola is purely intentional.

Avocet's professional quality AVMAC™ assem-

blers run on any PC-compatible with DOS or Xenix. And on VAX Unix. Just released, AVMAC Version 2.0 has major speed improvements to assure you lightning-fast assembly. Plus, enhanced compatibility with Intel, Hitachi, Motorola & other chip makers—so you can convert existing code more easily than ever before.

Each AVMAC package comes complete with our AVLINK™ linker, AVLIB™ librarian, AVREF™ cross-reference generator and new 200+ page AVMAC User's Guide—all the assembly tools you want and need.

After assembly, check your program with AVSIM™—widely acclaimed as the best simulator/debugger in the industry. AVSIM tests target μ P code right on your PC—with no special hardware. It's crashproof. And what you see is what you get: AVSIM's full-screen display gives you instant visual access to the entire CPU—registers, memory, I/O ports, even attached peripheral chips.



AVOCET

SYSTEMS, INC.®

THE SOURCE FOR PERSONAL μ P DEVELOPMENT TOOLS.

Target Microprocessor Families Supported

1802/1805	68000/68010	COP400
6502/65C02	68020	HD64180
6801/6301	8048/8041	NEC 7500
6804	8051/8052	TMS-32010
6805/6305	8085	TMS-32020
6809	8096	Z8
68HC11	F8/3870	Z80

Host Operating Systems

CP/M	DOS	PC Xenix	VAX Unix
AVMAC Macro Assemblers			from \$349
AVSIM Simulator/Debuggers			from \$379
Other Development Tools			Call

**CALL TOLL-FREE
800-448-8500***

to order or receive our latest catalog of microprocessor development tools

Try before you buy.

Order your AVMAC assembler and AVSIM simulator/debugger today and we'll include a special demo kit for both. Try the demo for 30 days. If you're not satisfied for any reason, return the unopened products for a full refund, less the \$35 demo/documentation kit which is yours to keep.

Avocet Systems. We help you get your job done, on time and on budget.

Avocet Systems, Inc., 120 Union Street
PO. Box 490AI, Rockport, Maine 04856

*Outside US and in ME, call (207) 236-9055

TLX: 467210 AVOCET CI FAX: (207) 236-6713

Avocet delivers all the tools you need—in 48 hours or less. Ask about our AVPROM™ and AVPAL™ programmers. And our NEW 8051 in-circuit emulator, development boards, AVPAS 51™ cross-compiler—and AVKIT™, the total Unix toolbox for DOS, including the incomparable VI editor.

© 1987, Avocet Systems, Inc. All rights reserved. VAX is a trademark of DEC. Unix is a trademark of AT&T. Xenix is a trademark of Microsoft. CP/M is a trademark of Digital Research.

Engineering Close-Ups

Printers encompass technologies from a wider variety of engineering disciplines than any other component of a computer system. Most design improvements go far beyond electronics and electromechanics into areas such as ballistics, chemistry, thermal mechanics, optics, fluid mechanics, and metallurgy.

At the same time, the engineering goals behind these improvements are easy to appreciate, since the ultimate

product, printing, is one with which we are all familiar.

Considering these two points about printer technology—its variety and concrete end-product—we thought it would be interesting to present close-up views of specific printer developments, written by engineers with firsthand knowledge of the problems involved.

The five close-ups that follow don't cover all the various printing technol-

ogies, but they do illustrate the engineering process that underlies any technological improvement: analysis, design, modeling, prototyping, and refining to a finished design.

As you'll see, printer technology is a mature but by no means static area of engineering.

—George A. Stewart
Technical Editor

Taming the Hot Heads

As printers get faster, print heads get hotter. Computer-aided design plays a major role in solving the problem.

Keith B. Davenport

A warning label ("Hot") appears on almost every current-model dot-matrix impact (DMI) print head. The need for that warning is a direct result of the increased speeds in today's printers. New print-head designs are capable of 200 to 300 characters per second. Just as important,

character throughput has increased due to improved printer firmware and increased paper slew rates. The negative side of increased throughput is that the print head has a higher duty cycle; it has less time to cool off.

Other than the safety issue, what's wrong with a hot print head? Operating at high temperatures reduces the useful lifespan of most materials or requires that more expensive, high-temperature materials be used. High temperatures reduce

the ferromagnetic qualities of most materials, which are the heart of any electro-mechanical device. The more energy wasted, the larger the power supply must be. Finally, a hot print head often reduces throughput because the printer must slow the printing rate at various times during printing to let the head cool off.

Most DMI print heads are very inefficient, with typically 94 percent to 99 percent of the input energy wasted. Figure 1 illustrates the various kinds of losses in the DMI design.

Engineers at Newbury Data Recording have been making DMI print heads since the early 1970s. Their first print head was a seven-pin device using coaxial solenoids to drive the print wires (see figure 2). Though it was in step with the state of the art at that time, the design had several disadvantages: The nonlaminated structure allowed for high magnetic "eddy current" losses; the completely encased coil restricted heat dissipation; the large remanent air gap in the rear bearing re-

continued

Keith B. Davenport is advanced techniques manager at Newbury Data Recording Ltd., Hawthorne Rd., Staines, Middlesex, England.

Graphically Speaking

Spock

IS THE LOGICAL CHOICE

NEW



ONLY 790⁰⁰

FEATURES:

- Single slot, 8 bit interface for PCs and compatibles
- 640x200, 350, 400, 480 or 800 x 400 or 960x350 (60 hz refresh), 1000x700 (interlaced), 30 Mhz video Rate max.
- 1024 x 1024 x 8 frame buffer
- 256 simultaneous colors from a palette of over 60,000
- Supports 25 commands in hardware including eight windows, plus viewports. Excellent window & icon management
- Compatible with most analog monitors including multi-scan types
- 'C' drivers included (source code provided)

Spock is a full featured graphics card for PCs and compatibles. The board uses the NCR 7300 color graphics controller making it capable of executing up to 3.75 million instructions per second. A DMA channel allows for high speed data transfer between the PC and the screen. The board uses an on chip sequencer to perform display refresh while the drawing processor draws images into its cache memory. During display blanking intervals, the images in the cache memory are downloaded to the frame buffer. In this way images are drawn very quickly without producing flashes on the display. The board supports the use of soft fonts allowing it to be tailored to specific applications such as scientific notation. It can support two modes of text; fast text and proportionally spaced. The high level command set reduces software development costs and improves performance. And much more... please call for more information.

PIXELAR

Imaging Systems Corp
21 Antares Dr., Unit 207
Nepean, Ontario, Canada
K2E 7T8

(613) 226-8727

Visa and American Express accepted
Custom and OEM inquiries welcome!

**Call us...
and let us
beam you a board**

HOT HEADS

duced the magnetic efficiency; and the large armature mass, required to carry the magnetic flux and drive the print pin, made the device mechanically inefficient, with poor response. As a result of these factors, the print head was limited to low-frequency operation and was quite inefficient (1.5 percent).

With this analysis in mind, engineers at Newbury Data Recording resolved the problems to provide designs for 9-, 12-, and 18-wire print heads that ran cool. This meant increasing the devices' efficiency.

The plan of action involved considerable mathematical work, CAD, and optimization using prototype models. Here's a summary of the process by which they maximized the efficiency of a DMI print-head design:

1. Generate the actuator (pin-drive) mechanism.
2. Describe the actuator mathematically.
3. Compile a computer program to optimize the efficiency.
4. Predict the overall performance using a finite-element analysis program.
5. Compare computer predictions with the actual model.
6. Realize a manufacturable design using CAD.
7. Use open construction to allow forced-convection cooling to occur during carriage motion.
8. Maximize the heat-conducting surfaces.
9. Use laminated structure to minimize the eddy currents.

Because of the decision to laminate, New-

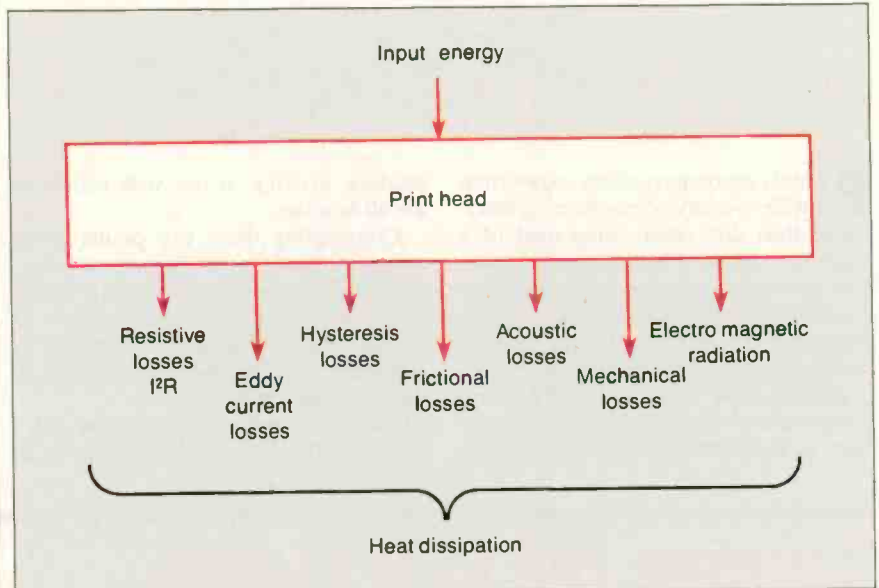

Figure 1: Types of losses associated with a DMI print head.

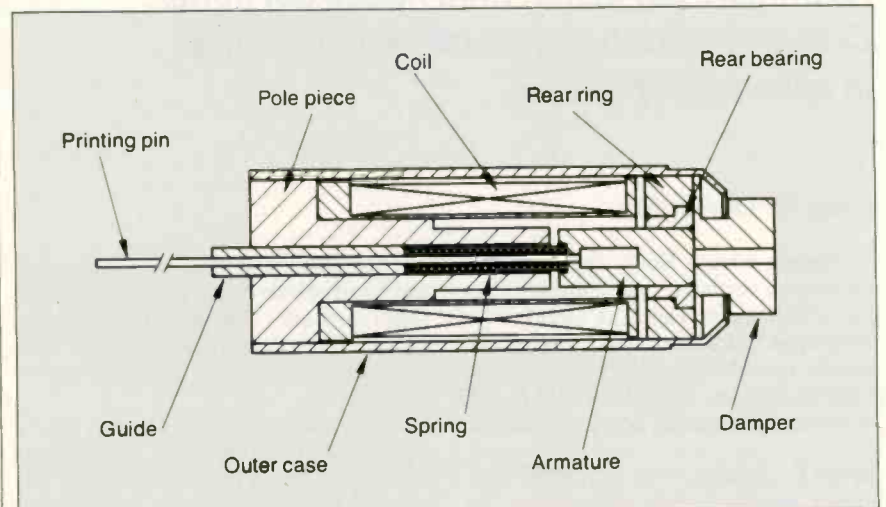

Figure 2: Coaxial solenoid used as an actuator in an early seven-pin design.

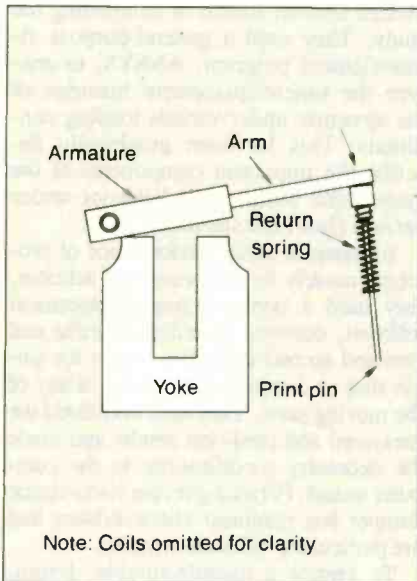
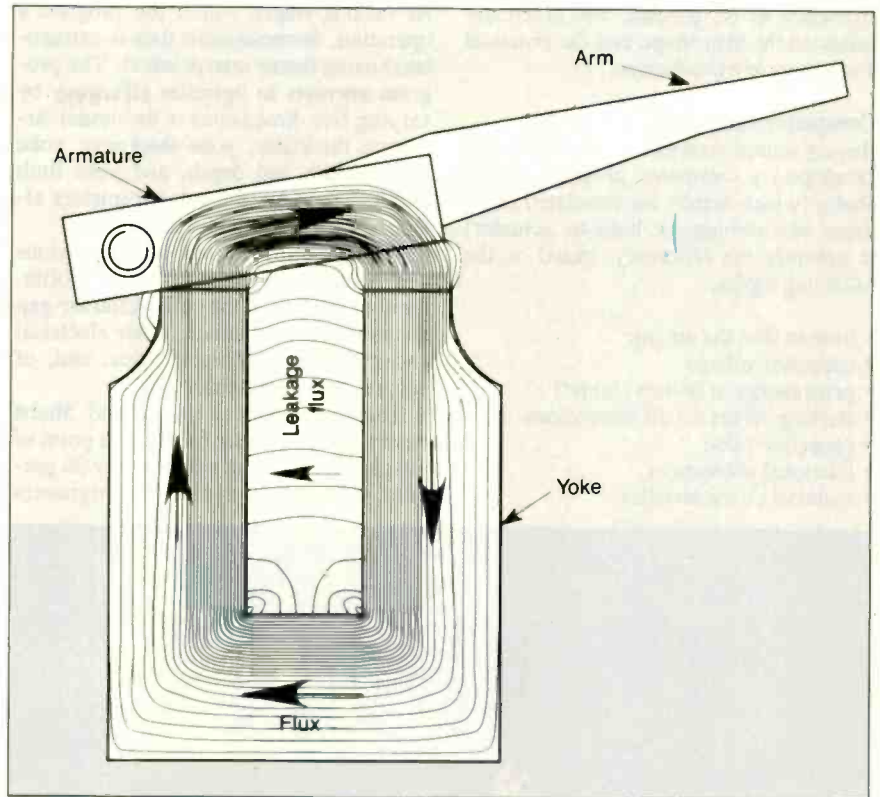

Figure 3: This U-shaped yoke and pivoted-armature model formed the basis of the computer-aided modeling process.

Figure 4: Flux distribution across the yoke and armature.



bury engineers rejected the previous coaxial design. A laminated cylinder is expensive to manufacture and is less efficient. Instead, they chose a simple U-shaped yoke with a pivoted armature (see figure 3) and used this design as the basis for a mathematical model describing the dynamics of the actuator to the point of air-gap closure (when the armature is pulled down by magnetic force onto the yoke).

The engineers made one major assumption about the magnetics of the model: The flux in the air gaps equalled the flux in the air gaps. Reluctance (magnetic resistance) was calculated as four components: yoke, air gaps, leakage, and armature.

Mathematical Model

The model describes every aspect of the print head: electrical, magnetic, and mechanical, as well as their interrelationships, and with respect to time.

When the coil receives an electrical pulse, the current generates a flux field concentrated in the yoke and passing across the air gaps (see figure 4). The flux field increases with time, accelerating the armature/arm/print wire assembly until the air gap closes, launching the print wire into free flight to place a dot upon the paper. The print wire returns by rebound, colliding with and imparting momentum to the arm; a visco-elastic damper absorbs most of the energy over the course of several bounces.

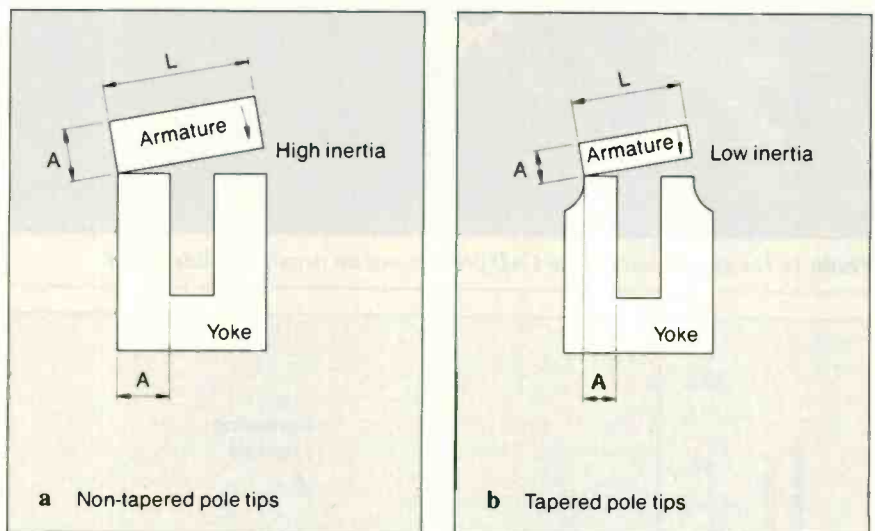

Figure 5: Nontapered yoke tips (a) and tapered tips (b). Tapering the yoke tips reduces the length and hence the inertia of the armature.

In modeling the electrical input energy, the engineers chose a capacitor-discharge circuit that provides an LCR (inductance-capacitance-resistance) network. They concentrated on the capacitor-discharge drive because it provides a constant energy input. However, two other designs can also be used by simple changes to the mathematical model: voltage drive and current limit. Providing an infinite value of capacitance would force the model to behave as a voltage drive, and

placing a current-limit trap in the algorithm would let it simulate a current-limit circuit.

To maximize the coil surface area and minimize leakage flux, they placed a coil on each limb of the yoke. Tapering the yoke tips let them (at the expense of magnetic saturation) significantly reduce the length and hence inertia of the armature, a function of $(\text{length})^3$ (see figure 5).

Within the armature/arm assembly, they calculated a theoretical mechanical

continued

efficiency of 65 percent, but much depends on the arm shape and the practical limitations of manufacture.

Computer Modeling and Design

Having settled on a model, the engineers developed a computer program called Sheba (which stands for simulated high-speed electromagnetic ballistic actuator) to optimize the efficiency, based on the following inputs:

- time to shut the air gap
- capacitor voltage
- print energy at launch ($\frac{1}{2}mv^2$)
- starting values for all dimensions
- capacitor value
- frictional allowances
- material characteristics

At various stages within the program's operation, ferromagnetic data is extrapolated using linear interpolation. The program attempts to optimize efficiency by varying five dimensions of the model: armature thickness, yoke thickness, yoke throat width and depth, and yoke limb width. These are the key parameters affecting the electromagnetic actuator.

The program outputs all dimensions and voltages, electrical current profile, number of turns in the coil, initial air-gap distance, time to launch, other electrical and mechanical characteristics, and, of course, the overall efficiency.

The mathematical model and Sheba describe the actuator only to the point of air-gap closure. Since this is only 30 percent of the total cycle, the engineers

needed another means of completing the study. They used a general-purpose finite-element program, ANSYS, to analyze the time/displacement histories of the structure under various loading conditions. This let them graphically describe the important components of the system and follow their behavior under various flux-field situations.

To measure actual performance of prototype models for the print-head actuator, they used a noncontacting displacement follower, deriving time/displacement and first and second derivative curves for single-shot or continuous operation of any of the moving parts. They then correlated the measured and predicted results and made the necessary modifications to the computer model. For example, the visco-elastic damper has nonlinear characteristics that are particularly difficult to model.

To ensure a manufacturable design, they made extensive use of CAD. All detail, assembly drawings, and the bill of materials were produced from a solids model (see photo 1).

The overall design is suited for a variety of product ranges, resulting in further benefits from using a computer model in the design. It was a straightforward process to produce components for a variety of print-head models by duplicating components in the computer model. The use of CAD also made possible the generation of complex three-dimensional and sectional views in any orientation—invaluable for checking manufacturability.

The resulting print head, incorporated into a capacitor-discharge drive circuit, requires only 4.7 millijoules per cycle per actuator (12 percent efficient); incorporated into a voltage drive circuit, the head requires 8 mJ/cycle/actuator (7.4 percent efficient). Contrast these numbers with typical industry figures of 11 mJ/cycle/actuator (6.3 percent efficient).

The Future

Still greater demands will continue to be made on DMI print heads, and therefore it becomes increasingly important to provide devices with higher efficiencies (see figure 6). The flapper or armature print head is limited in its performance by the high inertia of the moving parts. Stored-energy heads may become increasingly important because they offer potentially higher firing frequencies with better efficiency. [Editor's note: *The stored-energy design is described in "Matrix-Line Printing" on page 215.*]

The design approach summarized in this article—with suitable changes to the mathematical algorithms—will be equally beneficial to future print heads, keeping efficiency high and temperatures low. ■

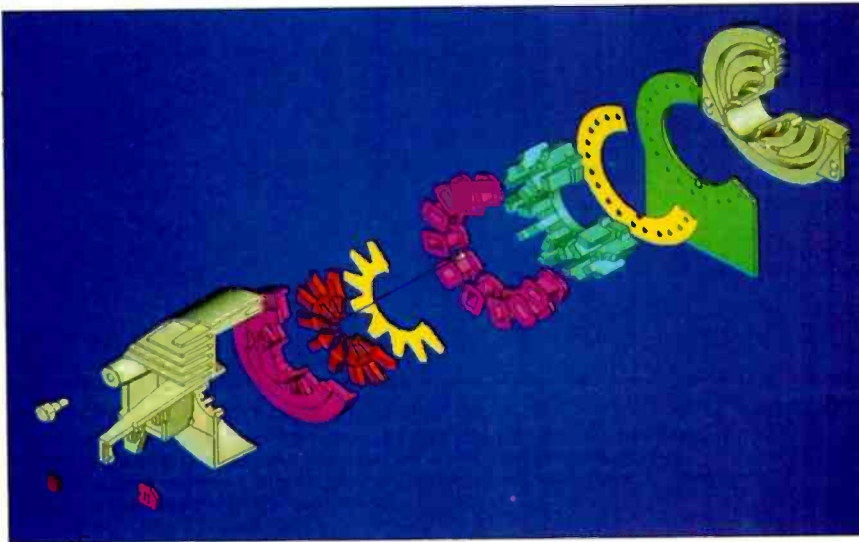

Photo 1: The culmination of the CAD process was an accurate solids model.

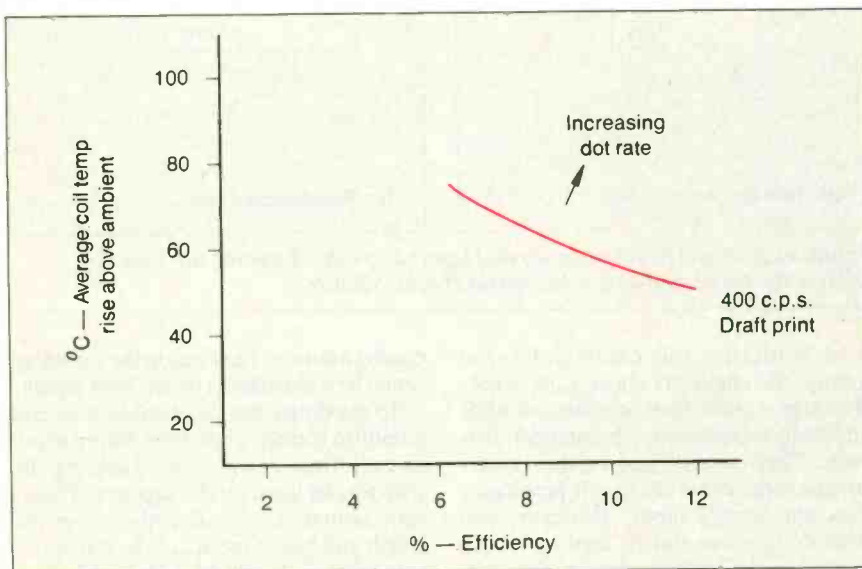
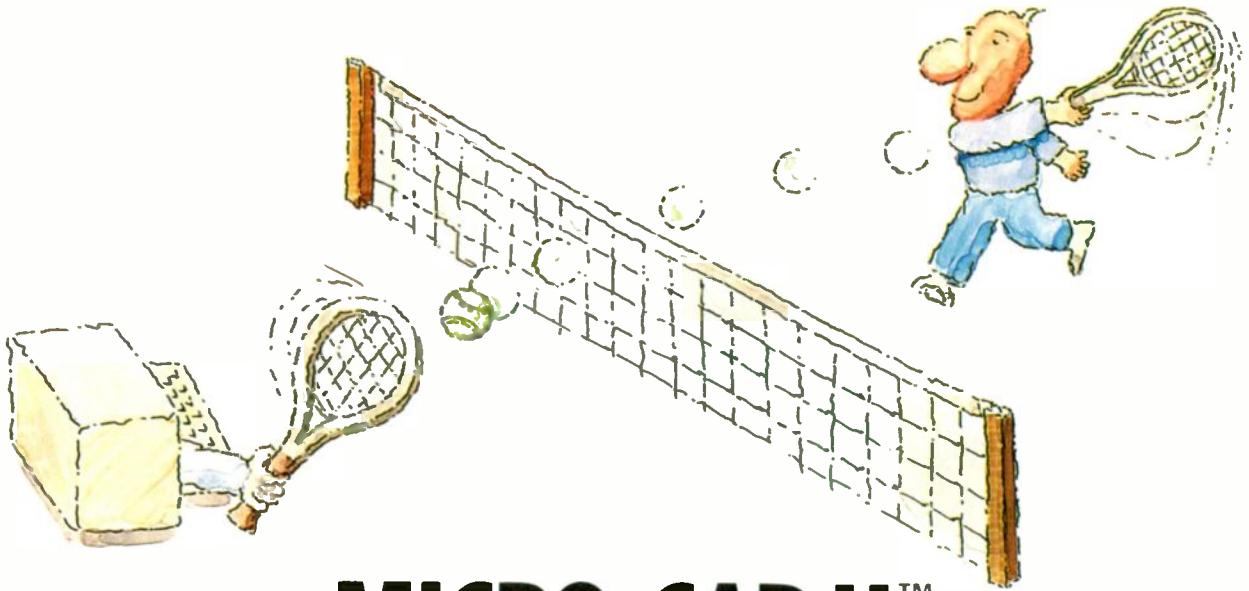

Figure 6: The curve shows the relationship between efficiency and head temperature for a 400-cps (draft mode) printer.



MICRO-CAP II.™

The CAE tool with fully interactive analog simulation for your PC.

Spectrum Software's MICRO-CAP II® is fast, powerful, and feature rich. This fully interactive, advanced electronic circuit analysis program helps engineers speed through analog problems right at their own PCs.

MICRO-CAP II, which is based on our original MICRO-CAP software, is a field-proven, second-generation program. But it's dramatically improved.

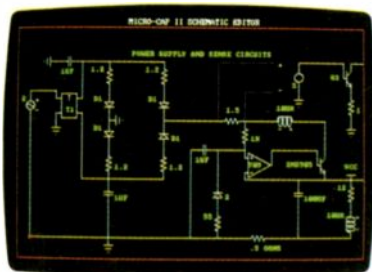

Schematic Editor

MICRO-CAP II has faster analysis routines. Better resolution and color. Larger libraries. All add up to a powerful, cost-effective CAE tool for your PC.

The program has a sophisticated integrated schematic editor with a pan capability. Just sketch and analyze. You can step

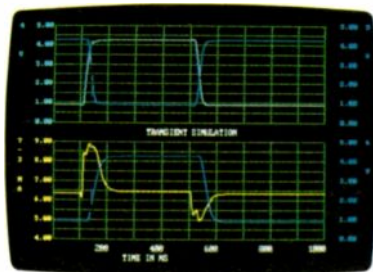

Transient Analysis

component values, and run worst-case scenarios—all interactively. And a 500-type* library of standard parts is at your fingertips for added flexibility.

MICRO-CAP II is available for IBM® PCs and Macintosh.™ The IBM version is CGA, EGA, and Hercules® compatible and costs only \$895 complete. An evaluation version is available for \$100. Call or write today for our free brochure and demo disk. We'd like to tell you more about analog solutions in the fast lane.

- Integrated schematic editor
- Fast analysis routines
- High-resolution graphic output
- Standard parts library of 500* types

*IBM versions only.

- Transient, AC, DC, and FFT routines
- Op-amp and switch models
- Spec-sheet-to model converter*
- Printer and plotter* hard copy



AC Analysis

Spectrum

1021 S. Wolfe Road, Dept. E
Sunnyvale, CA 94087
(408) 738-4387

MICRO-CAP II is a registered trademark of Spectrum Software.

Macintosh is a trademark of McIntosh Laboratory, Inc. and is being used with express permission of its owner.

Hercules is a registered trademark of Hercules Computer Technology

IBM is a registered trademark of International Business Machines, Inc.

GET SERIOUS



...ABOUT ANALYZING YOUR DATA.

You might be spreading your spreadsheet a little too thin. Or maybe you're starting from scratch. But if you're serious about data analysis, you're ready for SPSS/PC+™—a full software family that brings you eight high-powered ways to complete any data analysis task.

Enter it. SPSS Data Entry II™ is a fully integrated data entry, cleaning and editing tool.

Analyze it. The SPSS/PC+ base package provides a powerful array of statistical and reporting procedures.

Picture it. SPSS/PC+ Graph-in-the-Box™ featuring New England Software's Graph-in-the-Box™ offers full color "snapshot" graphics.

Examine it. SPSS/PC+ Advanced Statistics™ lets you get more serious with your data.

Predict it. SPSS/PC+ Trends™—our latest option—is the complete time series analysis/forecasting tool.

Table it. SPSS/PC+ Tables™ produces presentation-ready tables instantly.

Chart it. SPSS/PC+ Graphics™ featuring Microsoft® Chart creates show-stopping graphs and charts.

Map it. SPSS/PC+ Mapping™ featuring MAP-MASTER™ creates maps where vast amounts of data can be summarized and presented in one, simple picture.

SPSS/PC+ products are being put to productive use by serious fact finders in business, government and education. For countless purposes such as market research. Wage and salary studies. Survey analysis. And quality control. Plus each product is superbly documented and supported by SPSS Inc., a leader in statistical software for nearly 20 years. While specially tailored customer support is available through the VALUE PLUS™ plan.

So if you're serious about data analysis, step up to SPSS/PC+. For details, contact our Marketing Department.

CALL 1/312/329-3315

SPSS inc.

SPSS Inc. • 444 North Michigan Avenue, Suite 3000 • Chicago, Illinois 60611

In Europe: SPSS Europe B.V. • P.O. Box 115 • 4200 AC Gorinchem, The Netherlands • Telephone: +31183036711 • TWX: 21019

SPSS/PC+ runs on IBM PC/XT/AT's with hard disk. Contact SPSS Inc. for compatible microcomputers. SPSS/PC+, SPSS Data Entry II, SPSS/PC+ Graph-in-the-Box, SPSS/PC+ Advanced Statistics, SPSS/PC+ Trends, SPSS/PC+ Tables, SPSS/PC+ Graphics and SPSS/PC+ Mapping are trademarks of SPSS Inc. VALUE PLUS is a trademark of SPSS Inc. Chart and Microsoft are trademarks of Microsoft Corporation. MAP-MASTER is a trademark of Ashton-Tate. Graph-in-the-Box is a trademark of New England Software, Inc. © 1987, SPSS Inc.

Matrix-Line Printing

In this alternative to serial character printing, an 8-inch-wide bank of print hammers moves just 1/3 inch to print an entire line

Mark Hohneker

Matrix-line technology has been used in commercial, heavy-duty printers for over 12 years but has only recently been adapted for personal computing applications. I am going to explain some of the more unusual features of matrix-line printing as implemented in printers from Printronix.

The typical dot-matrix printer uses a print head with 9 to 24 closely spaced pins. The print head generates print characters in serial fashion, moving horizon-

Mark Hohneker is a technical writer for Printronix Inc. (17500 Cartwright Rd., P. O. Box 19559, Irvine, CA 92713).

tally back and forth across the full width of a page, printing a vertical bar of nine or more dots at each dot column position. In this design, printing speed is largely a function of the number of characters printed.

In matrix-line technology, 24 print hammers are arrayed horizontally on an 8-inch shuttle (wide-carriage designs use more print hammers and a wider shuttle). The hammers fire simultaneously, printing an entire horizontal line of dots with a single 1/3-inch sweep of the shuttle assembly. Figure 1 is a simplified drawing showing the design's major components.

During the course of this sweeping movement, each hammer prints a horizontal dot pattern for characters that belong in the 1/3-inch zone covered by that hammer. At a setting of 10 characters per inch in an 8-by-9 matrix, each zone contains 30 dots, or 3 characters.

At the completion of the horizontal sweep, the printer advances the paper by one dot row. The shuttle then reverses direction and prints the next row.

Although the matrix-line printer uses a hammer bank in place of a serially moving print head, it does maintain a logical

continued

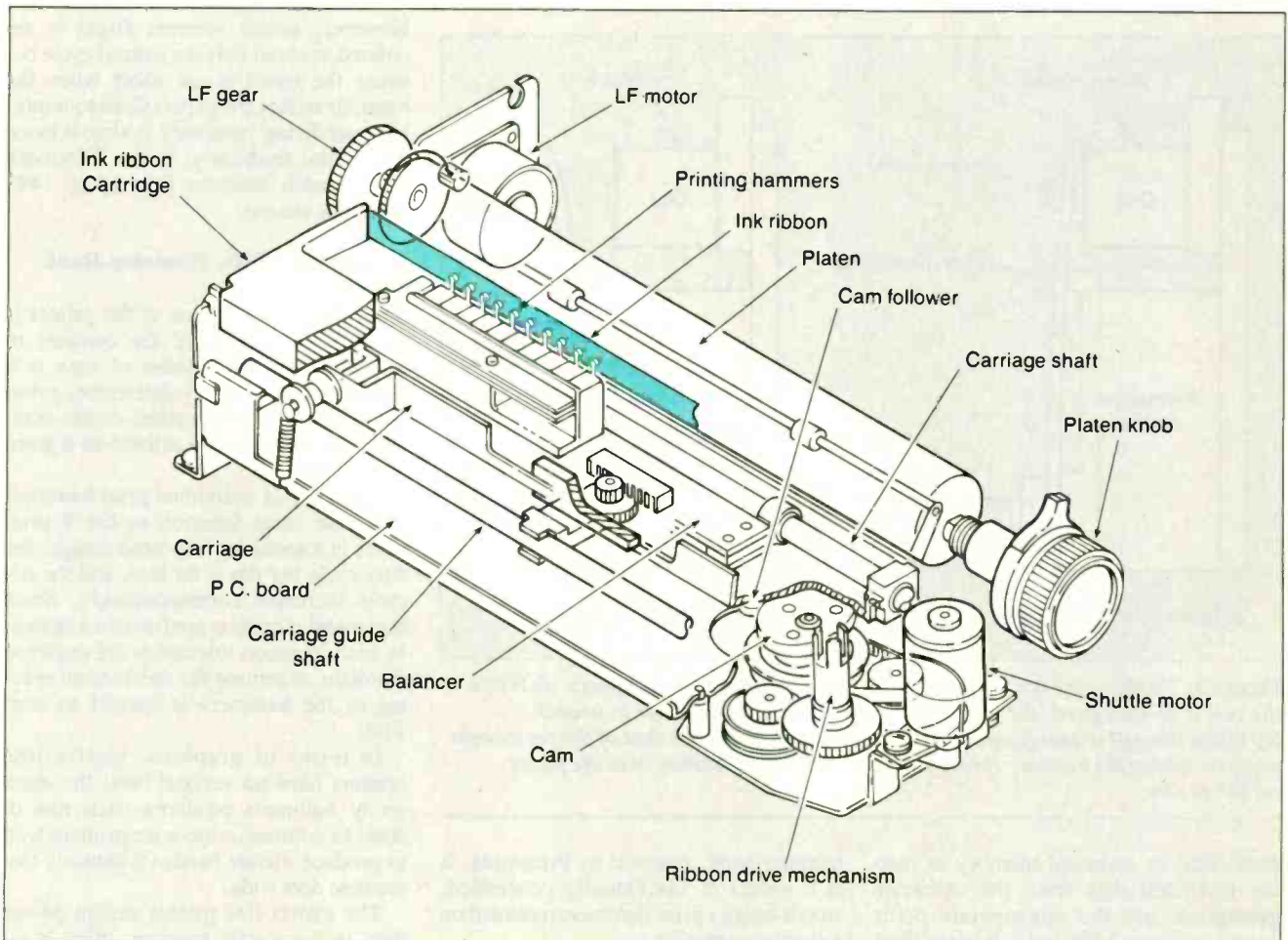

Figure 1: A simplified cutaway drawing of the matrix-line printer design, showing only 10 print hammers.

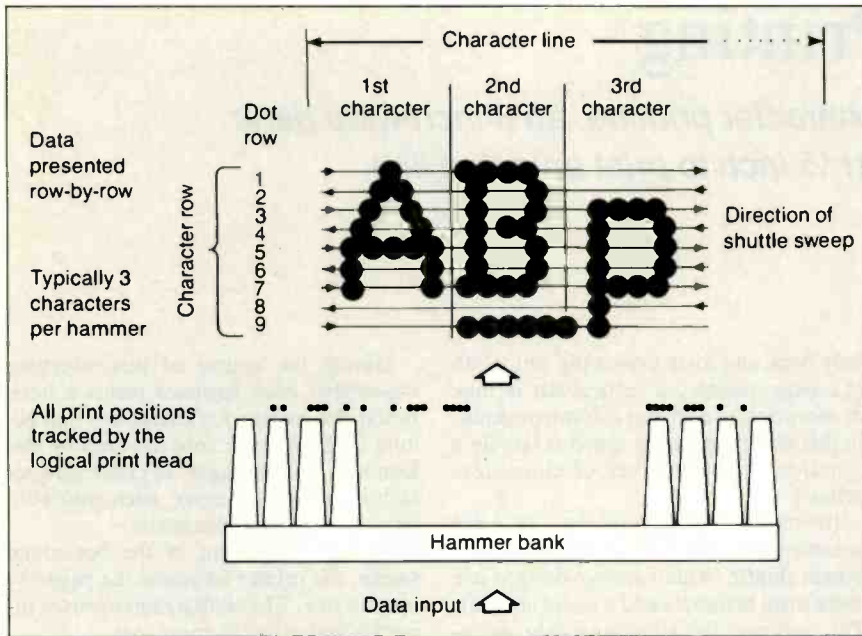

Figure 2: On-board printer firmware rasterizes a full line of text into a buffer called the logical print head, which is then mapped into the hammer bank. The figure shows the number of dots printed by a single print hammer to produce three characters in nine sweeps of the shuttle.

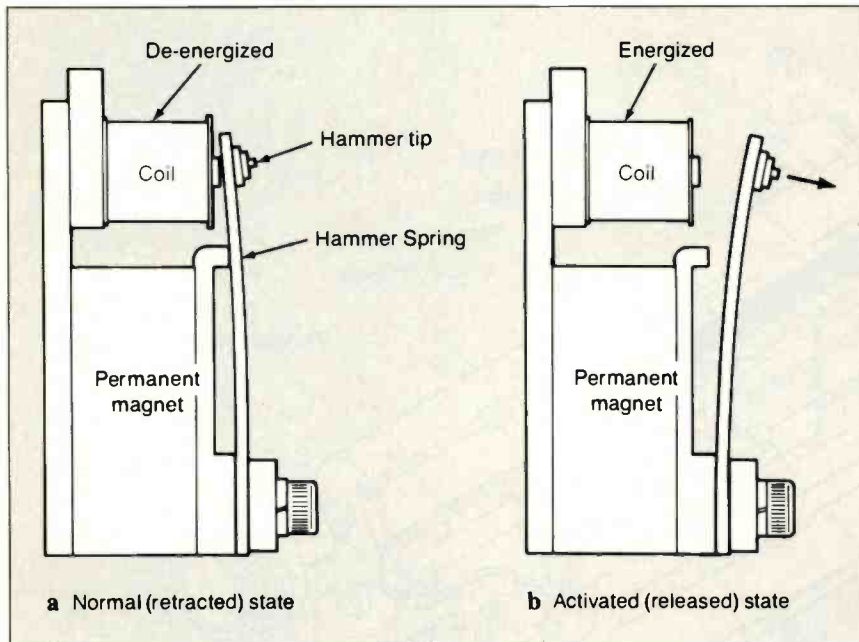

Figure 3: The hammer bank consists of 24 stored-energy print hammers. a) While the coil is de-energized, the permanent magnet holds the hammer in tension. b) When the coil is energized, its magnetic force field cancels that of the permanent magnet, letting the hammer spring forward, striking the ribbon onto the paper on the platen.

print head in on-board memory to map the rasterized data from the character generator into the appropriate print zones, as figure 2 illustrates in simplified form.

The key to matrix-line printing is the

hammer bank, patented by Printronix. It is a group of individually controlled, stored-energy print hammers mounted on a shuttle assembly.

The stored-energy print hammer consists of three basic parts: the print ham-

mer, a stiff leaf spring with an 8-mil carbide steel tip; a permanent magnet to hold the individual hammer retracted in tension (stored energy); and an electromagnetic coil.

When energized by a signal from the hammer-driver circuit, the electromagnetic coil neutralizes the effect of the permanent magnet and lets the hammer spring forward and strike the ribbon against the paper, printing a dot. The coil is immediately de-energized, letting the permanent magnet recapture the rebounding hammer.

Figure 3 shows the stored-energy print hammer in the de-energized and activated states.

The maximum frequency for firing a stored-energy hammer depends on the mechanical characteristics of the hammer spring. Its natural frequency is similar to that of a pendulum swinging from one extreme position through a midpoint to another extreme position and back:

$$f = 1/(2 \pi \sqrt{k / M_e}),$$

where k is the spring constant and M_e is the effective mass of the hammer tip. However, actual hammer flight is restricted to about half the natural cycle because the travel is cut short when the hammer strikes the paper. Consequently, hammer-firing frequency is almost twice the natural frequency. In the Printronix design, each hammer fires up to 1493 times per second.

Advantages of the Hammer-Bank Design

Since the shuttle motion of the printer is the same regardless of the contents of each dot row, the number of rows in a character matrix solely determines printing speed. It is independent of the number of characters to be printed on a given line of text.

Since the 24 individual print hammers serve the same function as the 9 print wires in a serial moving-head design, the duty cycle per pin is far less, and the life cycle increases correspondingly. Since horizontal motion is confined to a span of 1/3 inch, position tolerances are easier to maintain, assuming the mechanical spacing of the hammers is correct to start with.

In terms of graphics, matrix-line printers have no vertical bias; the same set of hammers produces each row of dots. In contrast, nine-wire printers tend to produce visible bands or patterns that are nine dots wide.

The matrix-line printer design proves that, in dot-matrix printing, there is indeed more than one way to put the dots on paper. ■

We Deliver Advanced Technology



Professional Image Board



12 MHz Multifunction Card



ATI-6/12 System 286

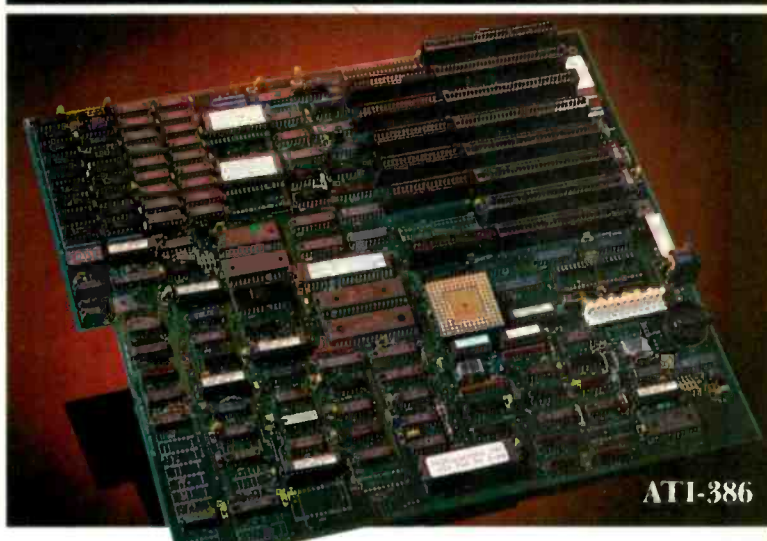

ATI-386

ADVANCE TO THE NEXT LEVEL

ATI-386

The ATI-386 AT board is a high-performance system board that provides the primary elements for building advanced personal computers. The board is functionally compatible with the system board in the IBM AT. However, it contains an 80386 microprocessor, 32-bit access to data and other features that give it over twice the performance of an 8MHz IBM AT.

Other features include downward compatibility with IBM 8 MHz AT, one MByte 32-bit on-board memory expandable to 16 MByte, a socket for the Intel 80387 math co-processor and more.

ATI-386-64

The ATI-386/64 Board features the same specifications as the ATI-386 AT board as well as on-board 64 KByte cache memory, cacheable to a full 16 MByte memory space to achieve nearly zero-wait state operation at full speed.

ATI-6/12 System 286

The ATI System 286-12 runs at an amazing speed of 12MHz. That's 20% faster than the IBM® Personal System 2 50/60.

And to protect your existing investment, we've built-in a normal-speed mode as well. A few simple keystrokes will switch you to 6MHz operation mode, when necessary.

Combine the ATI System 286-12 with our MegaGraph Plus EGA board to get superb graphics performance. Or expand your system's main memory with the ATI Multifunction card. Expand from single-user to multi-user system with up to five disk drive slots and eight expansion slots. 6/8 & 6/10 MHz systems also available.

12 MHz Multifunction Card

Our versatile multifunction card features a system bus of 12MHz. Sockets on board to handle up to 2.5 MBytes of memory, one serial port, one parallel port, one game port. Optional second serial port available.

Professional Image Board

The new Professional Image Board is a PC board which allows an ordinary home video camera (color or black-and-white) to be plugged into an IBM PC/XT/AT personal computers or IBM compatibles. Now, live, fast action scenes can be instantly captured in full color and frozen. The frozen pictures can be stored on a floppy or hard disk. The frozen pictures can also be transmitted to any remote computer in the world via modem or network.



ATronics International Inc.
We Deliver Advanced Technology

Inquiry 22

1830 McCandless Dr. Milpitas CA, 95035 USA
(408) 942-3344 TLX: 510-600-6093 FAX: (408) 942-1674

Southern California Contact: **CNT Marketing**
16580 Harbor Blvd., Ste. J, Fountain Valley, CA 92780 (714) 839-3724

IBM & ATronics are trademarks of their respective companies.



MOTOROLA



Macintosh II



Apple picked our brains.

And so did hundreds of other companies.

Before millions of people picked Macintosh,[®] Apple[®] picked Motorola's M68000 Family—the brains behind one of the most successful computer products ever launched.

Now Apple has tapped the brainpower of the Motorola MC68020 microprocessor for the Macintosh II, bringing the high performance of a graphics workstation to business desktops everywhere.

72% of all 32-bit systems ever shipped included at least one MC68020. That's more than half a million high-performance systems.

The high-performance business solution.

The MC68020 is not just the overwhelming choice in workstations—it is now setting new performance standards in the office—where it is essential to the computation, graphics and communication necessary for interconnected systems.

While Apple's choice of the MC68020 was a smart move, there's no license on genius: the '020 is the microprocessor of choice in advanced business system designs by such



industry leaders as Altos, Alpha Micro, Casio, C.Itoh, Fujitsu, Honeywell Bull, NEC, NCR, Olivetti, Plexus, Ricoh, Sanyo, Sharp, TI, Toshiba and UNISYS.

The graphics solution.

The M68000 family helped Apple implement the visionary "point and click" graphic workstyle that has driven productivity up while driving training costs way down. Businesses of all sizes are discovering dramatic productivity increases in office computing through innovations such as desktop publishing.

The software solution.

Among programmers and designers dedicated to creating the best, most innovative applications, the M68000 architecture has been the leading choice by far—with over *seven million* M68000 systems installed since 1979.

Meanwhile, the MC68020, on the market now for three years, is already backed by *two billion dollars worth* of 32-bit software.

This is more 32-bit software than all competitive products combined!

The Brain Trust: Where M68000 microprocessors predominate.

Engineering Workstations

Apollo, Hitachi, HP, Sony, Sun, Tektronix.

Laser Printers

Apple, Canon, HP, IBM, QMS, Ricoh.

Departmental Computers

Fujitsu, Honeywell Bull, NEC, NCR, UNISYS.

PBX and Telephone Systems

AT&T, Northern Telecom, Siemens.

Fault Tolerant Systems

IBM, NCR, Stratus, Tandem.

Supercomputers

Alliant, BBN, Caltech, Fifth Generation.

Factory Automation

Allen-Bradley, ASEA, Bailey Controls, GM, Mitsubishi, Square D.

Join the Brain Trust.

Challenge us to persuade you of the sound business and technical reasons to join the M68020 Brain Trust. Write to us at Motorola Semiconductor Products Inc., P.O. Box 20912, Phoenix, AZ 85036.

We're
on your
design-in
team.

Apple is a registered trademark and Macintosh is a trademark of Apple Computer, Inc.



MOTOROLA

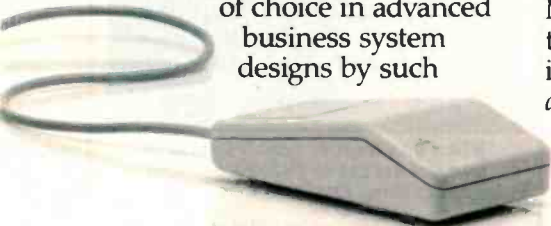

MICROPROCESSOR MASTERY!

The Development System that Supports 150 Different Microprocessors.

A complete solution

Here, at last, is the working environment of the future for developing error-free and efficient microprocessor code. Save time and money with UniLab II's seamlessly integrated toolset:

An 8/16-Bit Universal Emulator—With UniLab's full selection of symbolic debug commands you can quickly display and change all registers, memory, and ports, plus set software and hardware breakpoints.

An Advanced 48-Channel Analyzer

Most other development systems are dead in the water if there is a hardware fault, such as a simple bus short. Now, you can use the power of UniLab to home in on both software and hardware problems quickly.

An Input Stimulus Generator—You conveniently specify system inputs and observe the results.

A Built-In EPROM Programmer—helps finish the job!

Development Dreams Come True

Use UniLab's advanced windows to set up your screen the way you want to... view multiple items of interest. Imagine being able to automatically compare a current trace with previous trace data to instantly determine differences. You can set breakpoints, single-step, then go back to the analyzer without missing a beat. If you make a change in your code, use UniLab's built-in line-by-line assembler to instantly patch the fix and test the results. Think of the time savings.



Find Bugs Fast

Searching for bugs by single-stepping through suspect code can take forever. Now, with UniLab, just specify the bug symptom you are looking for as a trigger spec and let UniLab catch the

bug for you as your program runs in real time.

On-Line Help menus, Command Glossary, and Word List.

Pop-up Mode Selection panel called by soft key.

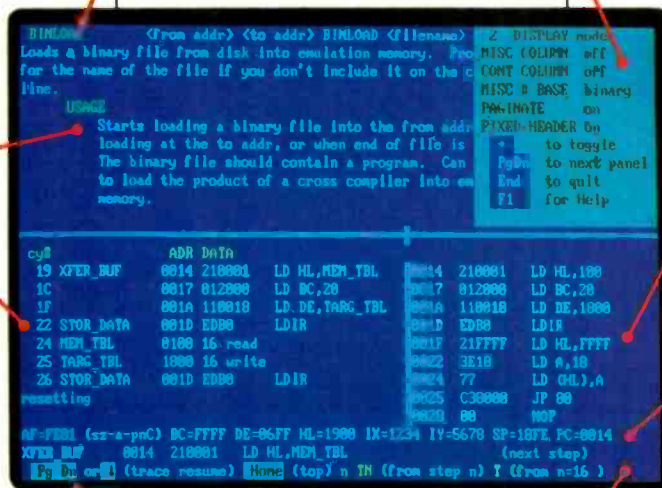

Windows can be used to view source files, previous traces, and more.

Symbol translation or source code line display.

Screen displays scroll off into history buffer—can be viewed later.

UniLab trace filtering eliminates extraneous information and shows you only the program steps of interest.

Context sensitive prompt line.

Get Running Fast

You probably won't use your development system every day. You do need a system that's easy to learn, and easy to come back to. That's UniLab. It lets you use commands or menus—or a mixture of both. The same commands work for all MPUs. Useful help screens, an on-line manual & glossary, instant pop-up mode panels, a quick command and parameter reference, are at the ready.

Affordable, Expandable

At less than \$5,000 UniLab costs less than our less-able competitors. You can add our new Program Performance Analysis option to help you

optimize your software. If you don't need UniLab's power, other models are available from \$2,995. Get the story on UniLab II and how it can revolutionize your software design efficiency, as it has for thousands. Universities, ask about our Education Outreach Discount Program.

Disassembly of code in memory can be compared with trace in adjacent window. Symbolic breakpoint register display.

Call Toll-Free 1-800-245-8500. In California call (415) 361-8883.

Set up for any 8- or 16-bit processor in seconds!

Thanks to our innovative emulation approach, moving between processor types requires only a new emulation module and software change. You save both money and time: Our inexpensive

Personality Paks™ (only about \$500) include all the items you need for fast hook-up. Orion MicroTargets™, functioning target circuits for popular MPUs, let you test your software before your own hardware is ready.

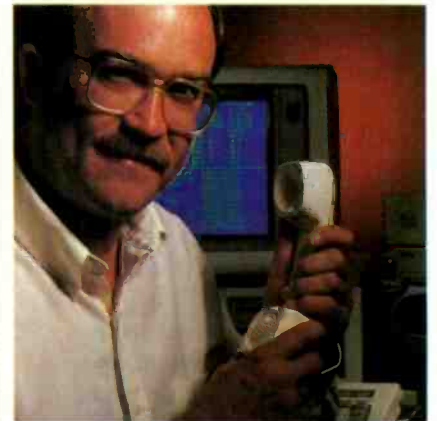

When you own or rent a UniLab II, you get access to Orion's team of Applications Engineers.

ORION
INSTRUMENTS, INC.

702 Marshall St.
Redwood City, CA
94063
TELEX 530942

Color Thermal-Transfer Printing

Getting good results requires solutions to a variety of engineering challenges

Julio Guardado

The thermal-transfer process is simple in principle, but its implementation for high-quality printing like that shown in photo 1 is quite complex. I'll describe some of the engineering challenges and show how CalComp solved them in designing a series of color printers.

In the thermal-transfer process, a donor ribbon coated with a solid ink is heated to the ink's melting point. The ink is then transferred to the receiving paper or film, to which it adheres after cooling. Figure 1 illustrates the process.

By repeating the process three times using combinations of inks of the three primary subtractive colors (yellow, magenta, and cyan), you can produce colors across the full spectrum.

Lining Up the Dots

Registration of the three passes is the first challenge. For instance, to produce a blue dot, the printer must place a dot of magenta ink directly on top of a yellow dot. The molten layers of ink mix to form a light filter that turns white light into blue. However, if the second dot is mis-registered, it ruins the effect. The ColorMaster design places up to 200 dots per linear inch, each dot with a 0.005-inch diameter. That doesn't leave much room for error in the placement of dots that are supposed to be overlaid.

Any multipass device is subject to errors caused by tolerance buildups in the mechanism. A small variance in paper positioning, added to a small variance in print-head positioning and a small amount of vibration, may result in a variance that exceeds the design tolerance. The thermal nature of the design introduces an additional source of variance: the expanding and contracting caused by changes in the moisture content of the medium.

To minimize registration error, ColorMaster uses a unidirectional media-feed mechanism. The paper or transparency film is fed from an automatic sheet feeder and clipped to a rubberized drum (with a circumference of 12 inches).

The media-handling drum makes three

rotations, exposing the paper to three panels of yellow, magenta, and cyan ribbon. Each pass takes about 20 seconds, yielding a page rate of one per minute.

The ColorMaster's unidirectional media transport avoids the backlash that can occur when a drive changes direction. The drum's rubberized surface also helps by overcoming the media's tendency to slip or change shape better than would a sprocket feed or friction feed; the holding force is spread out over the entire paper surface rather than being concentrated along the edges of the paper.

The net result of this media-handling system is an overall registration of about half a dot, which is well below the thresh-

old at which fringing and other undesirable visual effects appear.

Thermal Print Heads

As with any raster printing device, including impact printers, the designer has a choice between using a scanning head, which moves across the width of the page printing dots as it goes along, and a stationary head, which prints an entire line of dots simultaneously.

Stationary heads—because there are more of them and they print simultaneously—offer greater throughput than scanning heads. The design also reduces the problem of registration to one dimension,

continued

Photo 1: Sample output from the ColorMaster thermal-transfer printer.

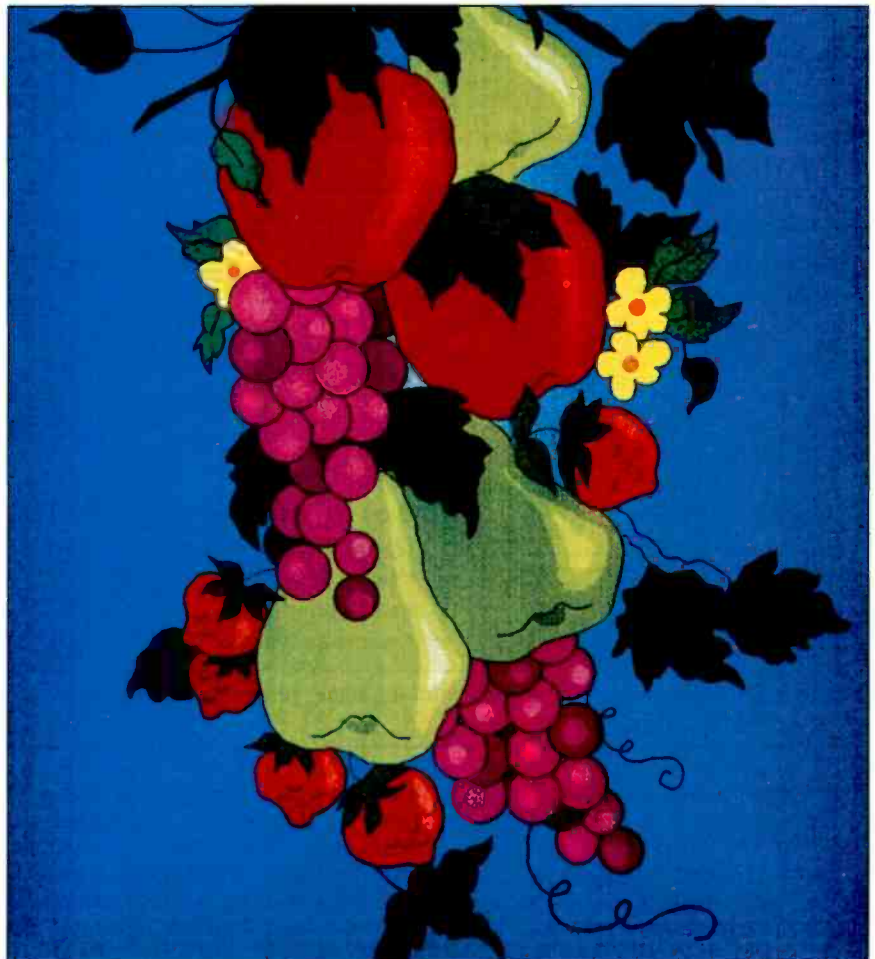

Julio Guardado is director of the small-format raster business unit at CalComp, a Lockheed Company (P.O. Box 3250, Anaheim, CA 92803).

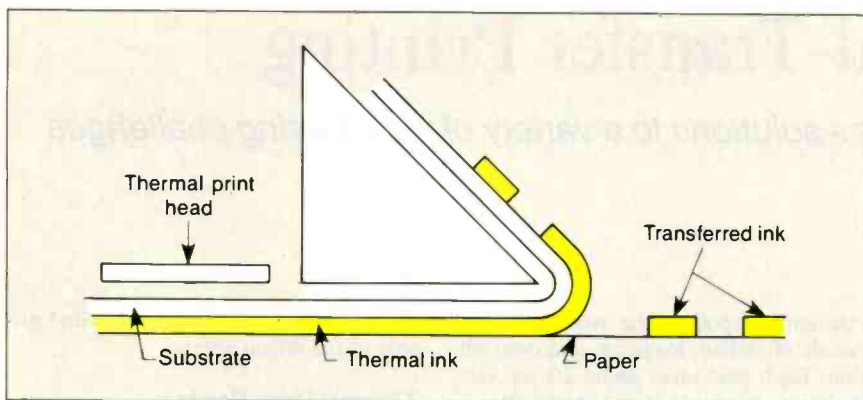

Figure 1: A simplified diagram of the thermal-transfer process.

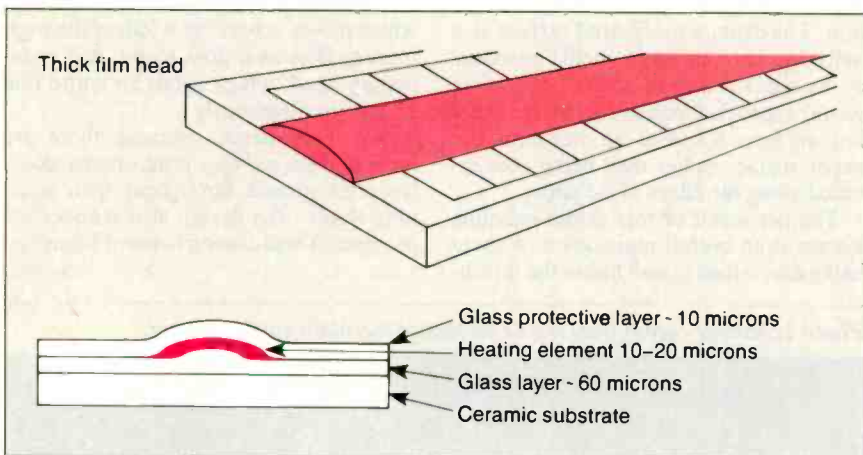

Figure 2: Thick-film heads offer durability and greater leeway in manufacturing tolerances.

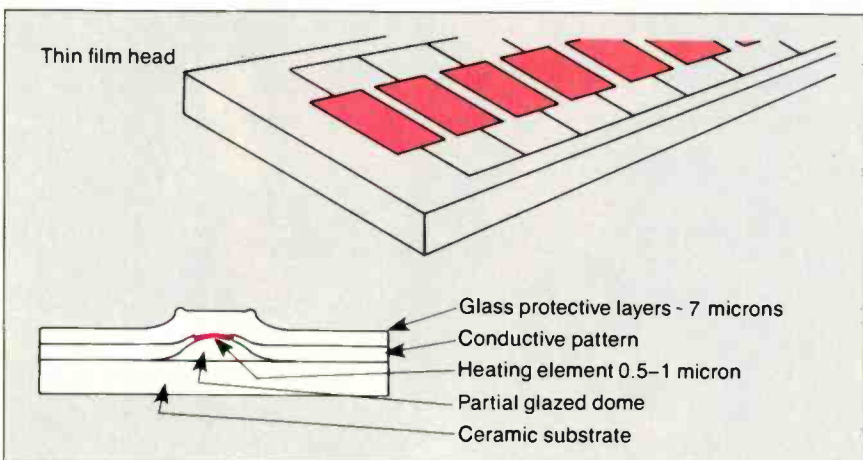

Figure 3: Thin-film heads offer the potential for higher resolution and are more energy-efficient.

since there is movement along one axis.

Thermal heads are either thick-film or thin-film. Thick-film heads (see figure 2) are manufactured by silk-screening a 0.015-millimeter-thick resistive material across an array of conductor leads. When power is applied to one of the leads, the

head heats up across the path of current flow, the shortest path between the two conductors. This creates a "virtual" print element—virtual because there is no distinct element. All the electronics to drive the head are built right onto the thermal head.

Thin-film heads (see figure 3) are manufactured much in the same way as ICs. A resistive material 0.5- to 1-micron thick is deposited between each pair of conductors, forming a discrete heating element. A protective glass layer 7 to 10 microns thick is applied to both print-head types.

Heat transfer from the heads to the ink is 20 percent efficient. The head heats to about 350° C within a span of about 1 millisecond, raising the ink temperature to its melting point of 70° C. To minimize power requirements, current is applied in multiple strobes.

By definition, thick-film heads are more durable than thin-film. They also allow higher tolerances in their mechanical design since they project farther from the background surface. Thin-film heads, on the other hand, can be manufactured less expensively, use about 20 percent to 30 percent less energy, and can provide higher dot densities.

The ColorMaster design uses a thick-film stationary head to maximize throughput and reliability while providing 200-dpi resolution. In terms of manufacturing, the key challenge has been to achieve element-to-element uniformity, since this largely determines the lateral evenness of color on the final printed page. Head uniformity is a function of the resistance distribution of the thick-film material. At the beginning of the ColorMaster's development, element-to-element variation was as high as 25 percent over all the elements. Heads now used in the ColorMaster production units have a variation of 5 percent over 95 percent of the elements.

Thermal Ribbon and Media

Thermal ribbon is a substrate coated with a heat-sensitive solid ink made primarily of waxes, oils, and dyes. Varying the ratio of these ingredients changes the viscosity, melting point, and, ultimately, image quality. The substrate itself introduces another variable, determining the efficiency of heat transfer from the heads to the ink.

Thermal-transfer printers usually output on paper or transparency film (for use with overhead projectors). The properties of these two media are quite different, and getting good results on both using the same ink and the same print head is another difficult challenge.

The Future of Thermal Transfer

Manufacturers of color thermal printers are currently working on several challenges: to lower the cost of the units through improvements to the manufacturing process, to provide even higher resolution through improvements to thin-film technology, and to allow printing on lower-cost, rougher papers. ■

TEST EQUIPMENT THAT MEASURES UP TO YOUR SPECIFICATIONS



DMM-300 \$79.95
3.5-DIGIT DMM MULTITESTER

Our best model. A highly accurate, full function DMM loaded with many extra features. Audible continuity, capacitance, transistor, temperature and conductance all in one handheld meter. Temperature probe, test leads and battery included.

- * Basic DC accuracy: plus or minus 0.25%
- * DC voltage: 200mv — 1000v, 5 ranges
- * AC voltage: 200mv — 750v, 5 ranges
- * Resistance: 200 ohms — 20M ohms, 6 ranges
- * AC/DC current: 200uA — 10A, 6 ranges
- * Capacitance: 2000pf — 20uf, 3 ranges
- * Transistor tester: hFE Test, NPN, PNP
- * Temperature tester: 0° — 2000° F
- * Conductance: 200ns
- * Fully over-load protected
- * Input impedance: 10M ohm



DMM-200 \$49.95
3.5 DIGIT FULL FUNCTION DMM

High accuracy, 20 amp current capability and many range settings make this model ideal for serious bench or field work. Tall stand for hands-free operation. 2000 hour battery life with standard 9v cell. Probes and battery included.

- * Basic DC accuracy: plus or minus 0.25%
- * DC voltage: 200mv — 1000v, 5 ranges
- * AC voltage: 200mv — 750v, 5 ranges
- * Resistance: 200 ohms — 20M ohms, 6 ranges
- * AC/DC current: 200uA — 20A, 6 ranges
- * Fully over-load protected
- * Input impedance: 10M ohm
- * 180 x 86 x 37mm, weighs 320 grams



DMM-700 \$49.95
3.5 DIGIT AUTORANGING DMM

Autorange convenience or fully manual operation. Selectable LO OHM mode permits accurate in-circuit resistance measurements involving semiconductor junctions. MEM mode for measurements relative to a specific reading. Probes and battery included.

- * Basic DC accuracy: plus or minus 0.5%
- * DC voltage: 200mv — 1000v, autoranging or 5 manual ranges
- * AC voltage: 2v — 750v, autoranging or 4 manual ranges
- * Resistance: 200 ohms — 20M ohms, autoranging
- * AC/DC current: 20mA — 10A, 2 ranges
- * Fully over-load protected
- * Audible continuity tester
- * Input impedance: 10M ohm
- * 150 x 75 x 34mm, weighs 230 grams



DMM-100 \$29.95
3.5 DIGIT POCKET'S ZE DMM

Shrink-pocket portability with no compromise in features or accuracy. Large, easy-to-read 5" LCD display, 2000 hour battery life with standard 9v cell provides over two years of average use. Probes and battery included.

- * Basic DC accuracy: plus or minus 0.5%
- * DC voltage: 2v — 1000v, 5 ranges
- * AC voltage: 200v — 750v, 2 ranges
- * Resistance: 2k ohms — 2M ohms, 3 ranges
- * DC current: 2mA — 2A, 4 ranges
- * Fully over-load protected
- * Input impedance: 10M ohm
- * 130 x 75 x 28mm, weighs 195 grams

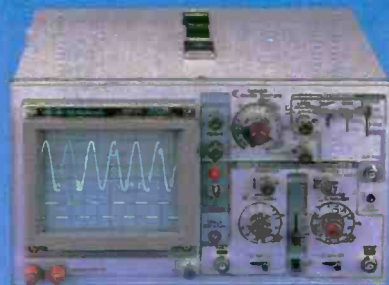

MODEL 2000 \$349.95
20 MHz DUAL TRACE OSCILLOSCOPE

Model 2000 combines useful features and exacting quality. Frequency calculation and phase measurement are quick and easy in the X-Y Mode. Service technicians will appreciate the TV Sync circuitry for viewing TV-V and TV-H as well as accurate synchronization of the Video Signal, Blanking Pedestals, VITS and Vertical/Horizontal sync pulses.

- * Lab quality compensated 10X probes included
- * Built-in component tester
- * 110/220 Volt operation
- * X-Y operation * Bright 5" CRT * TV Sync filter



MODEL 3500 \$499.95
35 MHz DUAL TRACE OSCILLOSCOPE

Wide bandwidth and exceptional 1mV/DIV sensitivity make the Model 3500 a powerful diagnostic tool for engineers or technicians. Delayed triggering allows any portion of a waveform to be isolated and expanded for closer inspection. Variable Holdoff makes possible the stable viewing of complex waveforms.

- * Lab quality compensated 10X probes included
- * Delayed and single sweep modes
- * Z Axis intensity modulation
- * X-Y operation * Bright 5" CRT * TV Sync filter



DPM-1000 \$54.95
3.5 DIGIT PROBE TYPE DMM

Autoranging, pen style design for the ultimate in portability and ease of use. Custom 80 pin LSI chip increases reliability. Audible continuity tester and data hold feature for added convenience. Case, test leads and batteries included.

- * Basic DC accuracy: plus or minus 1%
- * DC voltage: 2v — 500v, autoranging
- * AC voltage: 2v — 500v, autoranging
- * Resistance: 2k ohms — 2M ohms, autoranging
- * Fully over-load protected
- * Input impedance: 11M ohm
- * 162 x 28 x 17mm, weighs 75 grams

2 YEAR WARRANTY ON ALL MODELS



JDR INSTRUMENTS

110 Knowles Drive, Los Gatos, CA 95030

(408) 866-6200 • FAX (408) 378-8927 • Telex 171-110

Inquiry 137

COPYRIGHT 1986 JDR MICRODEVICES
THE JDR INSTRUMENTS LOGO IS A REGISTERED TRADEMARK OF JDR MICRODEVICES.
JDR INSTRUMENTS IS A TRADEMARK OF JDR MICRODEVICES.

ORDER TOLL FREE 800-538-5000

OR VISIT OUR RETAIL STORE
1256 SOUTH BASCOM AVE.
SAN JOSE, CA. (408) 947-8881

COMPUTER WAREHOUSE

CALL TOLL FREE **1-800-528-1054**

FREE FEDERAL EXPRESS
Air Express Shipping
See Details Below

NOW

BEST PRICES
No Charge for Bank Cards

HARDWARE

PRINTERS

AST Some Models	Call
Alps All Models	Call
Brother All Models	Call
Citizen MSP-10	\$249
MSP-15	\$315
MSP-20	\$285
MSP-25	\$385
Premier 35	\$445
Tribute 224	\$619
120 D	\$159
Diablo D-25	\$469
635	\$759
Diconixs 150	\$299

EPSON

All Printer Models	Call
Hewlett-Packard LaserJet II	\$1829
NEC	
3510, 3550	\$729
8810, 8850	\$1059
P6	\$429
P7	\$619
P9	\$1159

OKIDATA

All Printer Models	Call
Panasonic 1080 I	\$155
1091 I	\$169
1092 I	\$295
1592	\$375
1595	\$419
3131	\$229
3151	\$369

STAR MICRONICS

All Printer Models	Call
Toshiba 321 SL	Call
341E Parallel	\$995
351 Model II	\$899
Laser Printer	Call

DISKETTES

Maxell MD2 (Qty 100)	\$82.50
M2S	\$65
Sony MD/2 (Qty 100)	\$80

MONITORS

Amdex All Monitors	Call
NEC Multisync	\$545
Multisync Plus	Call
Multisync Graphic Board	Call
Princeton Graphics	Call
All Models	Call

VIDEO TERMINALS

Qume 101 Plus Green	\$315
101 Plus Amber	\$315
Wyse 30	\$285
50	\$359
75	\$565
Wyse 85	\$425

MODEMS

HAYES	
All Modems	Call
Prometheus All Models	Call
US Robotics Courier 2400	\$335
Password 1200	\$149
Microlink 2400	\$335
Ventel	Call

DISK DRIVES

Imega Bernoulli 10 meg	\$865
Bernoulli 20 meg	\$1190
Bernoulli 40 meg	\$1720

SEAGATE

20 meg w/Western I/O	\$339
Other Models	Call

FCC Approved

\$389

MIT

TURBO PC/XT

256 Memory, One 360K Brand Name Floppy Drive • 135 Watt Power Supply, Slide Case, AT Style Keyboard • 4-10 MHz Clock Speed, (Keyboard Selectable), 6 Expansion Slots

Turbo PC/XT w/640K & 1 Drive	\$439
Turbo PC/XT w/640K & 2 Drives	\$515
Turbo PC/XT w/640K	
1 Drive & 20 MG	\$799
PC/AT 10 MHz w/5 1/2K	
1.2 Floppy Drive	\$989
PC/AT 10 MHz w/1024K	
1.2 Floppy Drive	\$1039
PC/AT 10 MHz w/1024K	
1.2 Floppy, 40 MG	\$1625
MonGraphics Card with Parallel Printer Port	\$69
Color Card w/Parallel Printer Port	\$65
Multifunction Card w/Software	\$79
Amber Monitor (TTL)	\$89
Amber Monitor w/Swivel/Tilt	\$99
Color Monitor (RGB)	\$279
Sega Enhanced Graphics Card	\$145
I/O Card (Serial/Parallel)	\$38
I/O Card (Serial/Clock Calendar)	\$39
Enhanced Keyboard	\$69
AT Multi I/O Card	\$69
XT Multi I/O Card	\$55

BOARDS

AST	
Six-Pack Plus	\$139
Other Models	Call
ATI EGA Wonder	\$245
CSSL Awesome	\$375
Hercules Color Card	\$145
Graphic Card	\$175
Graphic Card +	\$185
Intel Above Board PS/PC (1110)	\$239
Above Board AT (4020)	\$315
Above Board PS/AT (4120)	\$345
Above Board PC 1010	\$210
NEC Multisync Graphic Board	Call
Orchid Tiny Turbo 286	\$355
Turbo EGA	\$449
Paradise Five Pak	\$99
Autoswitch 350	\$205
Autoswitch 480	\$279
Plus Development	
Plus Hard Card 20 Megabyte	\$609
Plus Hard Card 40 Megabyte	\$829
Quadram Quad EGA+	\$295
Tec Mar Graphics Master	\$409
Captain No Memory	\$109
EGA Master	\$239
EGA Prosync	\$335
Video-7 Vega Deluxe	\$285

COMPUTERS

TOSHIBA	
T-1100 Supertwist	Call
T-3100	Call

COPIERS

Canon

«PC»

Canon PC-25 \$929



SOFTWARE

IBM PC and 100% Compatibles

TRAINING

Flight Simulator	\$27
PC Logo	\$69
Typing Instructor	\$27
Typing Tutor III	\$27
MS Learning DOS	\$27

LANGUAGES

C Compiler (Microsoft)	\$249
Fortran Compiler (Microsoft)	\$245
Macro Assembler (Microsoft)	\$83
Pascal Compiler (Microsoft)	\$165
Quick Basic 2	\$55
Turbo Jumbo Pack	\$159
Turbo Pascal w/8087 & BCD	\$55
Turbo C	\$55
Turbo Basic	\$55
Turbo Prolog	\$54

PROJECT MANAGEMENT

Harvard Total Project Manager II	\$282
Microsoft Project	\$218
Super Project Plus	Call
Timeline 2.0	\$235

COMMUNICATIONS

CompuServe Starter Kit	\$19
Crosstalk XVI	\$88
MS Access	\$137
Mirror II	\$33
Remote	\$88
Smartcom II	\$79

INTEGRATIVE SOFTWARE

Enable 2.0	Call
Framework II	\$395
Smart Software System 3.1	\$409
Symphony	\$439
Ability	\$55

GRAPHICS

Logi Mouse	Call
Logi Buss Mouse w/paint	\$85
Newmaster	\$48
In-A-Vision	\$259
Microsoft Buss Mouse 6.0	\$103
Microsoft Chart	\$163
Microsoft Serial Mouse 6.0	\$115
Newsroom	\$31
PC Buss Plus Mouse	\$99
PFS: First Publisher	\$45
IMSI Mouse w/Dr. Halo II	\$92
PC Mouse	\$89
Printmaster	\$29
Signmaster	Call
Turbo Graphix Tool Box	\$38

WORD PROCESSORS

Leading Edge Word Processor	\$25
Leading Edge W/P/W/Spell & Mail	\$59
Turbo Lightening	\$55
Microsoft Word 3.11	\$175
Multimate Advantage II	Call
Wordstar w/Tutor	\$162
Wordstar Pro Pack 4.0	\$233
PFS: Professional Write	\$89

Word Perfect (Ver.4.2)\$195
Wordstar 2000 + 2.0 \$209

SPREADSHEETS

Lotus 1-2-3	Call
Multiplan 3.0	\$108
Spreadsheet Auditor 3.0	\$82
VP Planner	\$47

Supercalc 4 Call

MONEY MANAGEMENT

Dollars & Sense w/Forecast	\$92
Tobias Managing Your Money	Call

UTILITIES

MS Windows	\$55
Copy II PC	\$19
1 DIR Plus	\$46
Fastback	\$80
Norton Utilities 4.0	\$48
Printworks	\$36
Sidekick (Unprotected)	\$47
Travelling Sidekick	\$39
Sideways 3.1	\$37
Superkey	Call
XTree	\$25
SQZ	\$46

DATA BASE MANAGEMENT

Clipper	\$375
Cornerstone	\$53
dBase II	\$289
dBase III Plus	\$379
Extended Report Writer	\$175
KnowledgeMan II PromoPack	\$319
Quickcode Plus	\$138
QuickReport	\$138
Reflex	\$79
DB-XL	\$82
PFS: Professional File	\$112

R:Base 5000
System V \$415

Many other titles available.

Inquiry 65 for MS DOS Products. Inquiry 66 for all others.

COMPUTER WAREHOUSE

Order Line: 1-800-528-1054
Order Processing: 602-224-9345
8804 N. 23rd Ave.
Phoenix, Arizona 85021

Order Line Hours: Mon-Fri 7:00 a.m.-6:00 p.m.
Saturday 9:00-1:00
Alaska Orders: Call (602) 468-1731
Order Processing: (602) 224-9345
10:00 a.m.-3:00 p.m. Mon-Fri

* No Charge for VISA and MasterCard • You Pay the Ground Shipping—We Pay the Air • Ground Shipping & Handling \$6.00 • Free Air applies ONLY to orders up to 10 lbs. & Over \$50. • All products carry a manufacturer's warranty. All Guarantees, rebates, trial period privileges & promotional programs are handled by the manufacturer only. • NO APO, FPO, or international orders, please • Call before submitting PO Numbers • Personal and Company Checks Will Delay Shipping 3 weeks • Prices, Terms & Availability Subject to Change Without Notice • Add 3% for COD Orders • We Do Not Guarantee Machine Compatibility • All Sales Are Final



Designing a High-Speed Page Printer Controller

Fast forms processing is an ideal application for page printers. The controller is often the bottleneck.

Phil Ellison

Common sense tells us that an electro-mechanical print engine should be slower than an all-electronic controller, but the reverse is usually true. Most of the time, in a desktop page printer, the engine outperforms the controller. The engines are capable of printing at a rate of six or more pages per minute, while the controllers often feed the printer data at less than one page per minute. Unless the printer is producing the same page multiple times, the speed of the print engine is meaningless.

In electronic forms processing, the form exists as an electronic image until it is printed with the data filled in. The forms are designed, stored, managed, updated, and completed in computer memory and translated to paper only when needed in a paper format.

The controller bottleneck is a serious problem in forms processing, where the printer must turn out many different form sets every day. The requirements for forms printing are stringent. The controller must be able to handle complex combinations of fonts (sometimes as many as 36 per form plus 36 for the variable data to fill in the blanks), graphics, logos, and digitized signatures. The overall forms-processing system usually needs to be a turnkey system because its typical operators are not computer specialists.

Design Solutions

Most first-generation personal page printers have the controller built into the printer. In fact, the dedicated computers in those controllers are commonly more powerful than the microcomputers attached to them (for instance, a 68000-based printer attached to an 8088-based computer).

Placing the printer controller in the computer lets the computer's microprocessor handle memory-intensive page

makeup and processing operations. The controller writes the byte stream to the print engine. This approach eliminates duplicating parts of the computer system, such as chassis, memory, and power supply. It also eliminates the need to have font memory (RAM, ROM, or disk) in the printer and provides for a convenient user interface (the keyboard and display screen as opposed to a printer control panel and set of LEDs).

The controller we at EFS designed, the Formwriter Adapter Card (see photo 1), is a single board with a Motorola 68008 microprocessor, several custom logic arrays, and 256K bytes of 120-nanosecond RAM. It runs under a multitasking operating system written specifically for this application; the system can handle an unlimited number of separate tasks.

The operating system, written in assembly language, allocates resources by time slices and interrupts. Time slices control most of its activities, but important events, such as the horizontal sync pulses, generate interrupts. By design, the controller is fast but limited. It detects error conditions at the printer, for instance, but passes them on to the host processor for action.

Forms are created and stored in FGL (forms-generation language), a document description language optimized for forms. FGL resolution is 2400 dots per inch horizontally and vertically. This permits easy scaling to the resolution of the output device being driven.

A moderately complex form, compiled in FGL, like the IRS Form 1040 page 1, requires about 8K bytes to store. Variable information for forms is stored and managed separately and merged for display and printing. This eliminates the need to store the form multiple times.

The Computer/Printer Interface

The connection between the computer and page printer is often another bottleneck. Conventional serial connections are limited to 19.2K bits per second. Parallel connections at 56K bps are better,

but still not fast enough to keep pace with the print engine's capacity. Because a full page of graphics represents, on the average, about 1.05 megabytes of information, sending a full page over a parallel interface requires about 150 seconds.

The Formwriter Adapter Card connects directly to the video port of the laser engine over a shielded twisted-pair cable. The data-transmission rate ranges from 1.5 to 8 megabits per second, depending on the capacity of the print engine.

Almost all print engines receive data through a video interface. This means that one controller card can drive a variety of print engines, such as models from Xerox, Ricoh, and Canon. However, video interfaces differ among the various printers; there is no standard.

All the interfaces support the basic functions of control, status reporting, and image synchronization. Control commands allow the controller to start and stop the printer, select paper trays, control display indicators, and so forth. In some cases, commands are sent over a serial line using a command/response protocol. In other cases, commands are implemented using TTL signals.

Status functions allow the controller to monitor the condition of the printer and detect various errors, such as paper jams, out of paper, engine errors, and so forth. In some systems, the controller uses hardware signals to sample and evaluate the printer status in real time. More commonly, status information is passed over a serial communications line using a query/status exchange. Sometimes the control and status protocols are combined or intermixed in such a way that the controller might issue a print command and receive back a status response such as out of paper.

Image synchronization applies separately to the horizontal and vertical dimensions. The controller needs to know when the printer's photoreceptor is positioned at the top of the page and when to

continued

Phil Ellison is engineering manager at Electronic Form Systems. He can be contacted at EFS, 2395 Midway Rd., Carrollton, TX 75006.

HIGH-SPEED CONTROLLER

begin sending raster data for each scan line down the page.

A print command typically initiates the vertical synchronization sequence. When

it has a page ready to print, the controller issues a print command and the printer responds with a vertical sync signal that begins the print cycle. The controller

then looks for horizontal sync signals from the printer and sends one scan line of raster image for each horizontal sync, progressing down the page.

Again, the specifics of sending the raster image vary with each printer. Normally the image is sent at video rates of 1.5 MHz or higher and is synchronized with a video clock signal that is provided by the printer. The printer samples the video data signal at each strobe of the video clock and writes a dot when the signal is TRUE.

Implications for Other Printer Applications

The EFS Formwriter Adapter Card proves that the controller does not have to bottleneck the printing system. However, it is not intended as a general-purpose printer controller, rather it is optimized for forms processing.

Page printers have raised the expectations of many personal computer users with regard to traditional word processing and data reporting. Don't be surprised if the next generation of general-purpose page printers incorporates many of the design concepts that we found to be so effective in driving page printers at top-rated speed. ■

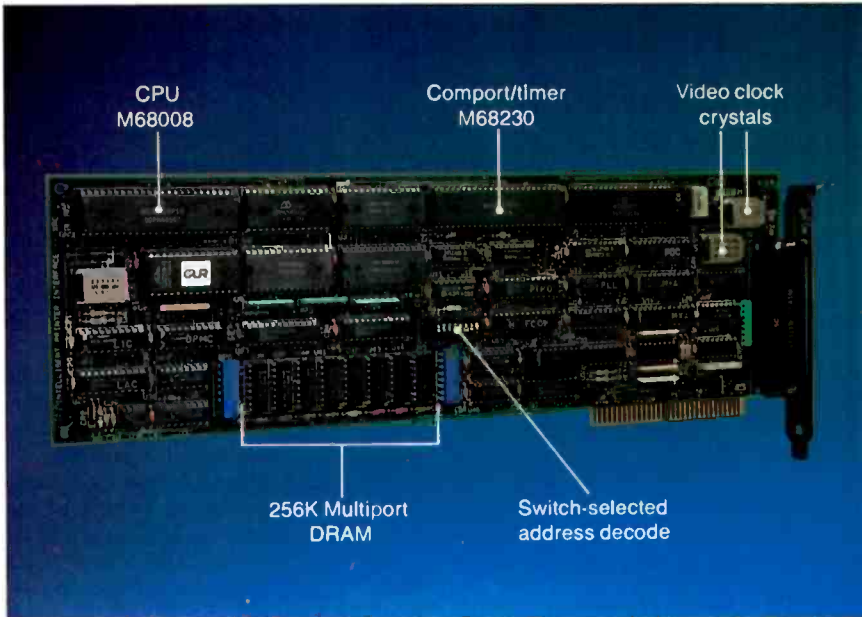

Photo 1: The Formwriter Adapter Card can control a variety of printer engines from Xerox, Ricoh, and Canon.

Hardware Specials

- AMSTRAD PC1512 SYSTEM
2 drives & mono monitor, IBM compatible \$679⁹⁵
- ATARI 1040ST COLOR SYSTEM
complete with RGB monitor \$839⁹⁵
- BLUE CHIP PC
512K with dual 360K floppy drives \$529⁹⁵
- COLOR GRAPHICS ADAPTOR
with parallel printer port \$59⁹⁵
- COMMODORE 128 SYSTEM
includes 1571 drive & monitor \$499⁹⁵
- COMMODORE 64C SYSTEM
includes 1541C drive & monitor \$399⁹⁵
- COMMODORE PC10-1 SYSTEM
with 1 floppy & 20MB hard disk \$799⁹⁵
- EGA ADAPTOR
Card for IBM and compatibles \$179⁹⁵
- EXTERNAL 2400 BAUD MODEM
for IBM and compatibles \$199⁹⁵
- FLOPPY DISK 10-PACK
double sided/density 5.25-inch \$9⁹⁵
- 360K FLOPPY DISK DRIVE
1/2 height internal, IBM & compatibles \$89⁹⁵
- GAME PORT CARD
for joystick & mouse, IBM & compatibles \$29⁹⁵
- INTERNAL 1200 BAUD MODEM
1/2 card with software, IBM & compatibles \$99⁹⁵
- SEGATE 20MB HARD DRIVE
1/2 height with controller \$299⁹⁵
- SEGATE 30MB HARD DRIVE
1/2 height with controller \$369⁹⁵
- 30MB HARD CARD
fast access, easy installation \$399⁹⁵
- 20MB HARD CARD
fast access, easy installation \$349⁹⁵

J&R MUSIC WORLD



**Impact Plus
XT Compatible Hard Disk System**
•640K RAM •30MB hard disk •360K floppy drive •4.77/8m Hz turbo •Monochrome monitor & card •Epson LX-800 dot matrix printer with cable •DOS 3.1 •Keylock security system •150 watt power supply

Sale Price **\$1099** List \$1550



**The Amiga 500
Color Personal Computer**
•Amiga 500 with 512K RAM and built-in 3.5" drive...\$699 •1080 matching RGB color monitor...\$349 •512K upgrade to 1 megabyte RAM...\$199

Sale Price **\$1250** List \$1700

Monitors

- AMDEK 310A
12-inch hires amber display with PC cable \$139⁹⁵
- EPSON MBM-2095
12-inch green display for Equity & IBM \$89⁹⁵
- MAGNAVOX 623
12-inch non-glare amber display w/cable \$84⁹⁵
- MAGNAVOX 8562
13-inch RGB color monitor for IBM w/cable \$279⁹⁵

Printers

- EPSON FX-286E
240 cps dot matrix, 136-column, parallel \$449⁹⁵
- EPSON FX-86E
200 cps dot matrix, with tractor, parallel \$339⁹⁵
- SEIKOSHA SP-1000VC
Dot matrix, with Commodore interface \$179⁹⁵
- SEIKOSHA SP-180AI
100 cps dot matrix printer, parallel \$149⁹⁵

Software Specials

- AMERICAN PRO INSET 2
Merges graphics & word processing/IBM \$79⁹⁵
- ASHTON TATE ADVANTAGE 2
Version 3.7 for IBM systems \$269⁹⁵
- BORLAND TURBO C
Development system for IBM \$59⁹⁵
- BRODERBUND PRINT SHOP
Create signs, letters & more, IBM \$34⁹⁵
- ELECT. ARTS Chuck Yeagar's
Advanced Flight Simulator, IBM \$27⁹⁵
- ELECT. ARTS DELUXE PAINT II
For Amiga computers \$79⁹⁵
- FUNK SOFTWARE INWORD
New for IBM and compatibles \$69⁹⁵
- INFOCOM LURKING HORROR
New interactive adventure for IBM \$27⁹⁵
- INT. MICRO SYSTEMS CADD 3.0
graphics drawing for IBM \$69⁹⁵
- NEWTech DIGIVIEW
Video digitizer for Amiga systems \$149⁹⁵
- PROGRESSIVE MEGABOARD II
2MB expansion for Amiga \$499⁹⁵
- PROGRESSIVE SUPERBASE
powerful database for IBM \$89⁹⁵
- REFERENCE GRAMMATIC II
Educational software for IBM \$59⁹⁵
- SIERRA LEISURE SUIT LARRY
For IBM and compatibles \$27⁹⁵
- SPS: FIRST PUBLISHER
desktop publishing for IBM \$69⁹⁵
- SUBLOGIC FOOTBALL
An incredible computer simulation, IBM \$29⁹⁵
- WORD PERFECT VERSION 4.2
for IBM and compatibles \$199⁹⁵

To Order **800-221-8180** In New York, Alaska & Canada
Toll Free Call: (718) 417-3737

Special Inquiries Invited — Prices Effective Through September 30, 1987

HOW TO ORDER BY MAIL: SEND MONEY ORDER, CERTIFIED OR CASHIER'S CHECK, MASTERCARD, VISA or DISCOVER CARD (include card number, Interbank No., expiration date and signature.) TO: J&R MUSIC WORLD, 59-50 QUEENS-MIDTOWN EXPRESSWAY, DEPARTMENT BMO987, QUEENS, NY 11378 DO NOT SEND CASH. Personal and business checks must clear out Authorization Center before processing. \$25 MINIMUM ORDER. Shipping, Handling & insurance Charge is 5% of Total Order with a \$3.95 minimum. (Canadian Orders Add 15% Shipping, with a \$9.95 minimum charge.) For shipments by air, please double these charges. SORRY, NO C.O.D.'s. NEW YORK RESIDENTS PLEASE ADD SALES TAX. ALL MERCHANDISE SHIPPED BRAND NEW, FACTORY FRESH, AND 100% GUARANTEED. WE ARE NOT RESPONSIBLE FOR ANY TYPOGRAPHICAL ERRORS.

59-50 Queens-Midtown Expressway, Queens, NY 11378



Introducing Printer Control Worth Showing Off

DUET™

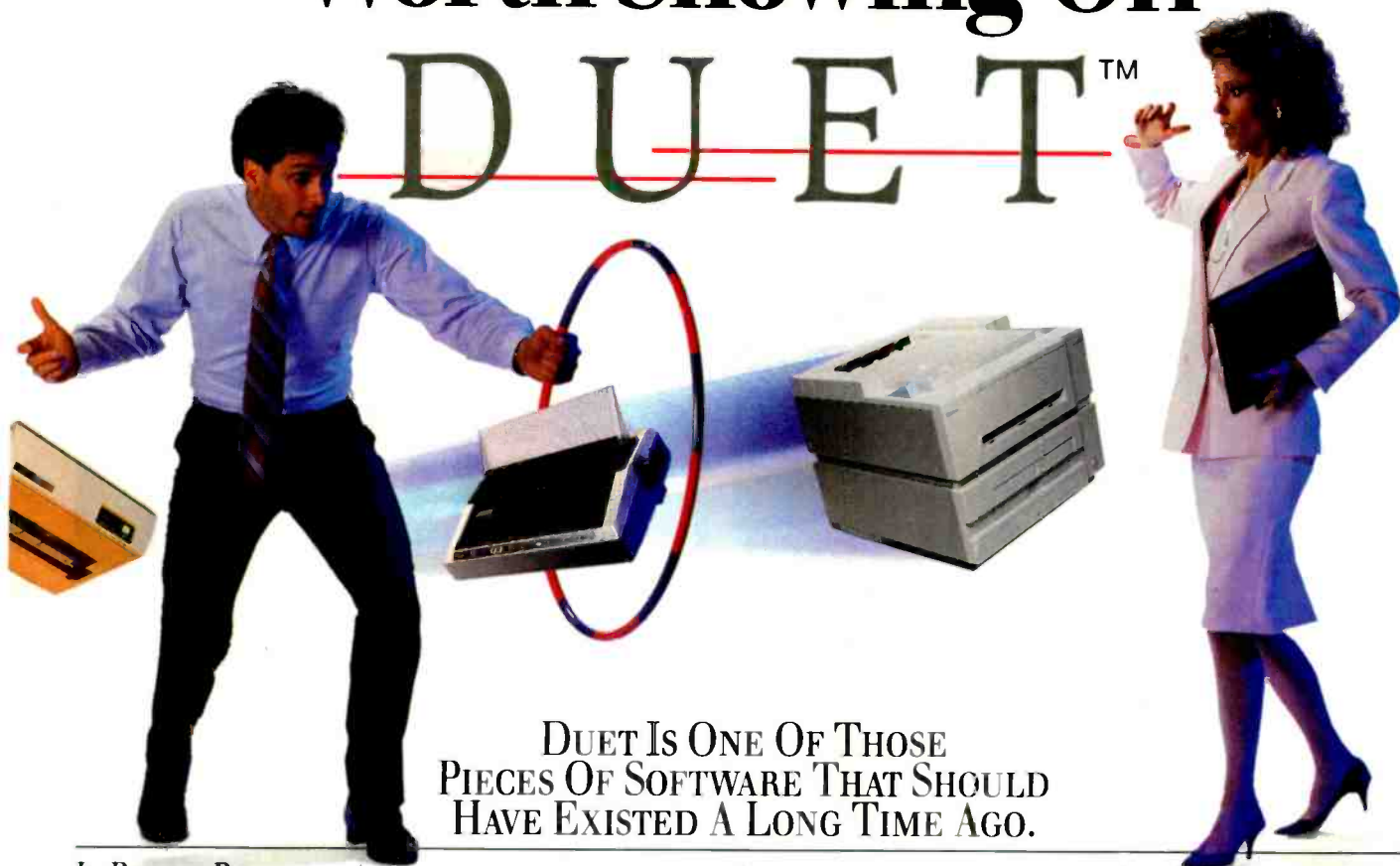

DUET IS ONE OF THOSE
PIECES OF SOFTWARE THAT SHOULD
HAVE EXISTED A LONG TIME AGO.

IT BEGINS BY
MAKING *RESIDENT*
ONSCREEN PRINTER
CONTROL A
REALITY... AND
THEN IT GOES
A WHOLE LOT
FURTHER.



Just because you need to
print something sideways...
doesn't mean you have to
turn your whole world
upside down!

We've out-sidewaysed Sideways™
...and that's only one part of
Duet! Duet decodes and prints
spreadsheets and text sideways
in the background...while you
and your computer go off in
other directions...together!

**When you swear at your printer...
does that help you remember how
to get it into compressed mode?**
Duet's pop-up menu allows you to select
compressed print or double width, letter
quality or draft. You can change spacing,
choose a font or easily command what-
ever else your printer has to offer. You
can even advance your paper a page or a
line at a time without having to approach
your hardware. On laser printers you
can choose between landscape and por-
trait modes, select paper tray and lots
more. And you'll never have to memorize
escape sequences to do it. Duet can make
your word processor, spreadsheet or
database report generator do things with
the printer it never knew was possible.

**When you need to stack up
a bunch of files to be printed,
do you ever feel like you're just
groping in the dark?**

With Duet, you can see a list of what's
waiting to be printed, any time you want.
You even have the ability to go in and
shuffle things around, cancel files and
individually configure print jobs for
sideways or normal print.

Power failure? Printer jam?
Anyone who's been around printers
for a while knows the feeling of groping
around for a power switch while paper
flies in all directions and the
print head bores a hole in your
masterpiece. That's why Duet
saves print queues to disk. When
you bring the power up again, or
clear the confetti out of your
printer, you'll be able to restart
wherever you left off...or even
back up a page or two if necessary.

**Have you ever been
forced out of your own office
because someone came to
visit while your printer was
hammering away?**

Duet lets you quiet your printer
with a keystroke, and then start up
again when it's convenient for you...
and you'll never miss a character.

With all of its power, Duet is so easy
to use that in five or ten minutes, it will
feel like an old friend. And like any true
friend, it's never intrusive. Depending
on how you configure it, Duet can occupy
as little as 60K of RAM.

\$89.95*

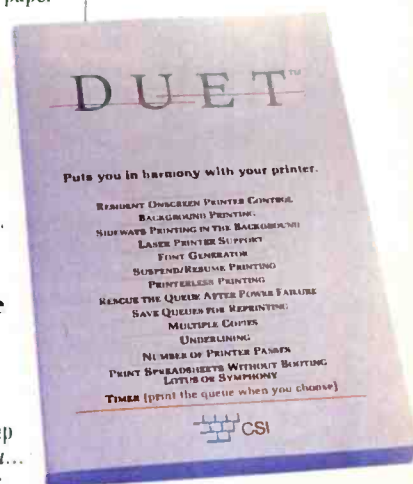

To order your copy of Duet direct, phone:
800-645-5501 or, in California dial
800-556-6699. Or mail us your name
and address along with a check, money
order, or your Visa, MasterCard or
American Express number and expira-
tion date. *California residents, please
add sales tax (6 1/2%). For orders outside
of the U.S. please add \$15. CSI, 736
Chestnut Street, Santa Cruz, CA 95060.

CSI is the original developer of The Spreadsheet Auditor, and the producer of the premier LAN electronic mail system: The Network Courier.

LOTUS AND SYMPHONY ARE TRADEMARKS OF LOTUS CORPORATION. SIDEWAYS IS A TRADEMARK OF PUNK SOFTWARE.

Inquiry 329

SEPTEMBER 1987 • B Y T E 227

Now Project Computer Data With Color.

Use color to clarify
your presentation and
excite your audience
for less than \$1600.



All you need is a personal computer, overhead projector and a new color MagnaByte II™ Electronic Imager to instantly share colorful computer data with a room full of people.

The MagnaByte II LCD display palette transforms the color data that appears on your monitor into an electronic "transparency" utilizing selected colors for added impact. Even if your computer system is monochromatic MagnaByte II will project in deep blue and yellow. When placed on an overhead projector, the data and graphics that were once confined to your small monitor are simultaneously projected onto any wall or screen. No additional hardware or software is required. Just connect the palette and remote control to the interface card provided with MagnaByte systems and turn on the computer. Exclusive MagnaByte circuitry provides quick, convenient setup including automatic image centering.



This new color MagnaByte II system can be used with IBM PC/XT/ATs and most IBM compatibles such as the Telex Intelligent Workstation. A monochromatic version of the MagnaByte is compatible with the Apple II family including the GS series.

Both models come with a multilingual software program allowing you to capture and assemble information onto your own presentation disc.

For a **free brochure** about this exciting new color LCD technology plus the name of your dealer, phone or write to: Telex Communications, Inc. 9600 Aldrich Av. So., Minneapolis, MN 55420.

Call Toll Free:
1-800-328-5727 ext. 8812.
In MN 1-800-742-5685 ext. 8812.

TELEX®

Strip-Buffer vs. Full-Page Bit-Map Imaging

As printer resolution increases, the cost of a full-page bit map goes up quadratically. Strip-buffer technology is a memory-thrifty alternative.

Bert Douglas

One of the jobs of a printer controller is to convert a page of two-dimensional objects (text characters and other shapes) into a sequence of dot rows that can be transmitted to the engine for printing. That job is getting harder as the number of dots increases.

With traditional full-page bit-map designs, the controller generates a bit-map image of the entire page to be printed; one bit in memory corresponds to one dot location on the printed page. The image is not sent to the print engine until the entire page is ready.

This method allows for virtually unlimited complexity on the page, but it also requires a lot of memory. At a resolution of 300 dots per inch, an 8½-by 11-inch image requires a megabyte of RAM; doubling the resolution to 600 dpi ups the memory requirement to 4 megabytes.

Time is another cost of the full-page

Bert Douglas is a senior design engineer with Office Automation Systems Inc. He can be contacted at OASYS, 8352 Clairemont Mesa Blvd., San Diego, CA 92111.

bit-map approach. The two-cycle mode of writing the image and then copying it to the print engine frequently results in waiting periods between pages, making it difficult for the system to meet the rated speed of the printer.

Strip-buffer imaging is an alternative technology that minimizes memory requirements while sacrificing some of the capacity for complexity. Another purpose of the design is to ensure that the controller drives the print engine to its throughput capacity, regardless of the contents of the pages.

Strip buffering is similar to the virtual-memory technique used in large computers to provide a logical address space larger than the available physical memory. The logical address space is the print drum, and the physical address space is the strip buffer (see figure 1).

The strip buffer is a narrow, horizontal bit matrix (typically 256 by 2550 bits). At any given time, the content of the strip buffer is a partial-page bit image.

The bit image can consist of any arrangement of predefined text characters

and graphics, with certain limitations. Each individual text character and graphic object must be able to fit entirely within the strip buffer. (However, some graphic elements, such as lines and boxes, can be larger than the size of the strip buffer.) The constraints in no way hinder the use of the system for general forms printing and word processing, but they might make it unsuitable for extremely complex graphic arts work.

Imaging a Page of Text

In the strip-buffer controller design, printing and imaging take place simultaneously. While one line of dots is being output to the print engine, another line is being written into the strip buffer. The top row of bits from the strip buffer is output to the print engine, the remaining lines of the buffer scroll up one row, and a new line of dots fills the bottom row of the strip buffer.

Printer software in the host computer sends a page of text in the form of a display list (i.e., a sequence of instructions for printing). The display list is a concise, high-level description of the page to be printed. A typical page-display list is only about 1 percent as large as a full-page bit-map description.

Inside the controller, a display-list interpreter (DLI) goes to work on the display list, generating rasterized data for the strip buffer.

To illustrate the operation of the DLI, I'll follow its handling of a hypothetical stream of commands from a simple display list. For the sake of simplicity, I'll reduce the dimensions of the output: Page size is 20 by 50 dots rather than the typical 3300-by 2550-dot page. The strip buffer is 10 dots deep rather than the usual 256 dots. The character matrix is 5

continued

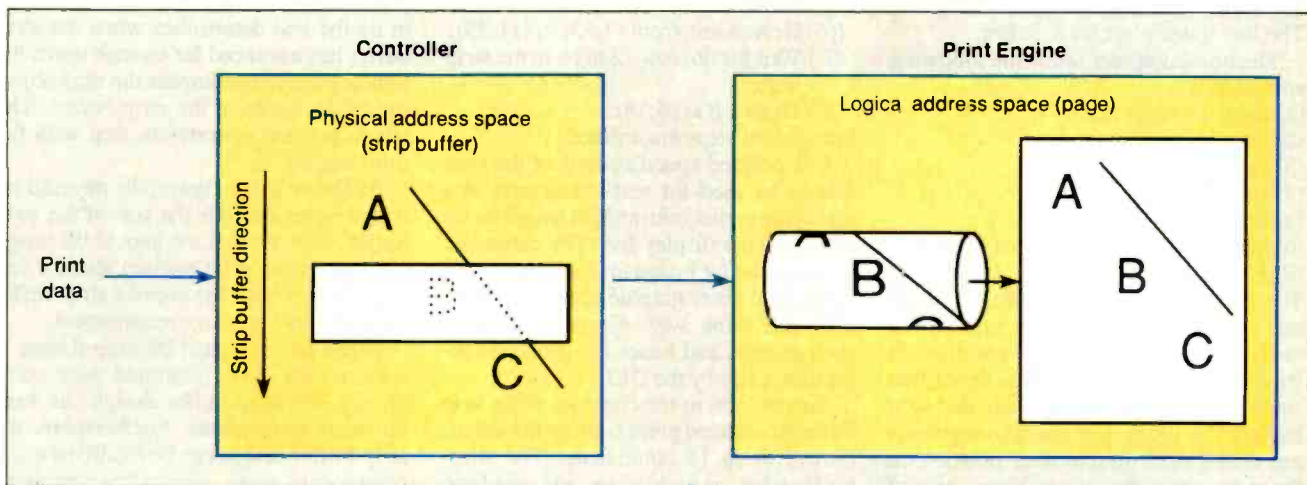

Figure 1: At any given time, the strip buffer contains only a partial-page bit image. In a process similar to virtual-memory techniques, the physical address space of the strip buffer scrolls across the much larger logical space of the printed page.

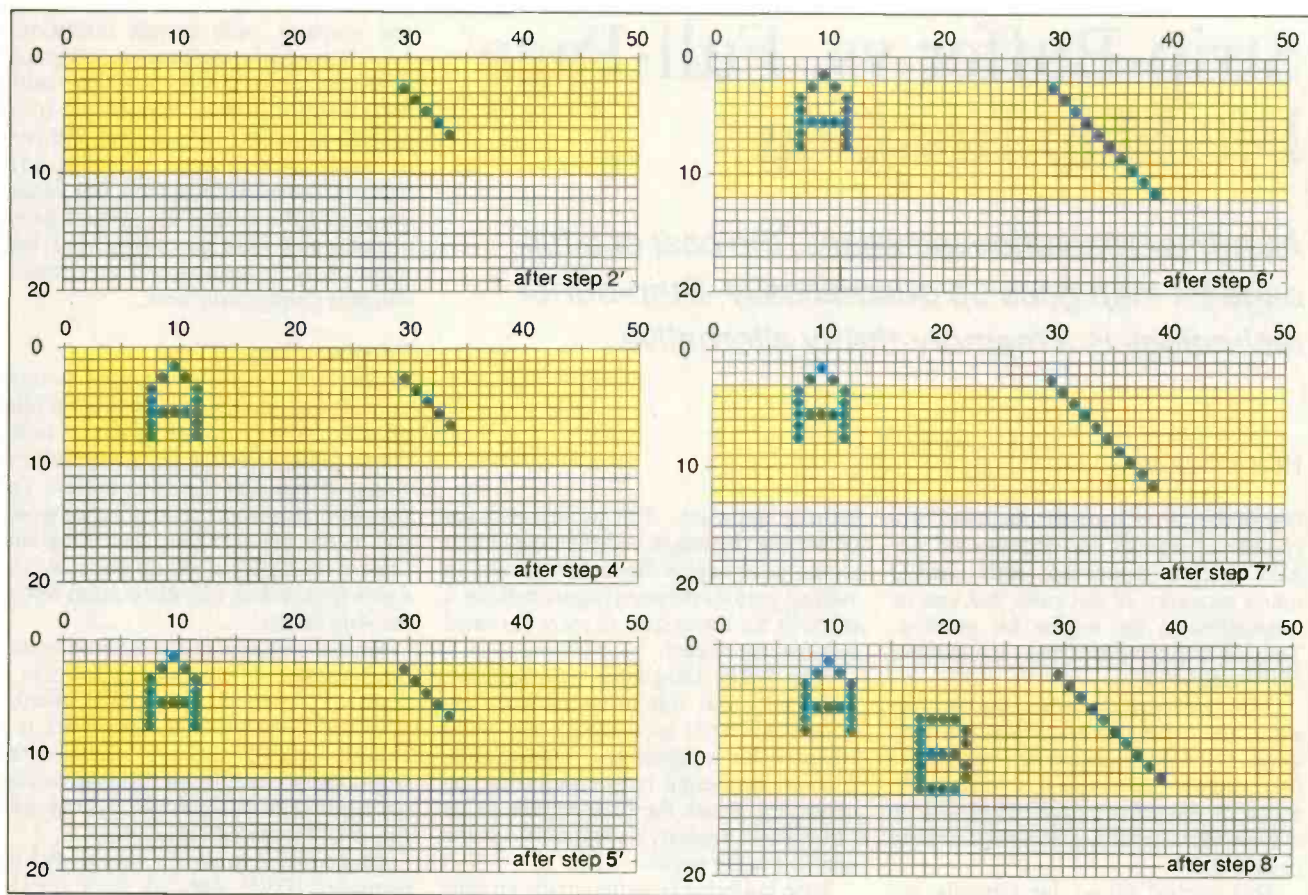

Figure 2: Step-by-step imaging of a simplified page using the strip-buffer technique. Not all steps are shown.

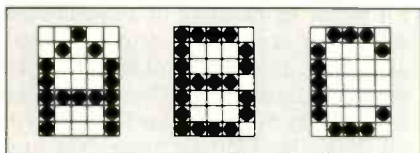

Figure 3: Character matrices.

by 7 dots rather than the typical 32 by 40. The line space is set for 5.5 dots.

The host computer sends the following commands:

- (1) Print the letter A.
- (2) Do a linefeed.
- (3) Print a B.
- (4) Do a linefeed.
- (5) Print a C.
- (6) Draw a line from (2,30) to (19,47).
- (7) Print the page.

The DLI scans through the list to find all the graphic elements that exceed the buffer size (such as the line specified in (6) above). These are broken down into smaller units that will fit into the strip buffer. The characters and line segments are sorted according to their position on the page, using the lowest dot position of each object as the sort key.

The DLI generates a new display list, inserting dot-row wait commands before

every object located at a dot row greater than that of the preceding object:

- (1') Wait for dot row 6 to be in the strip buffer.
- (2') Draw a line from (2,30) to (6,34).
- (3') Wait for dot row 7 to be in the strip buffer.
- (4') Draw an A at (1,8).
- (5') Wait for dot row 11 to be in the strip buffer.
- (6') Draw a line from (7,35) to (11,39).
- (7') Wait for dot row 12 to be in the strip buffer.
- (8') Draw a B at (6,18).

Subsequent steps are omitted.

I've omitted specifications of the type font to be used for text characters; in a real system, that information would be included in the display list. The controller looks up the bit image for each character. Logos and other graphic objects are handled the same way. Graphic elements such as lines and boxes are generated algorithmically by the DLI.

Figure 2 traces the contents of the strip buffer at selected points during the execution of these 15 commands. The strip-buffer rows are highlighted with shading. Note that the character reference point is the upper left corner of its matrix, as shown in figure 3.

Recall that I assumed a line spacing of 5.5 dots. The first linefeed moves the cursor down 5 dots, and the second one moves it down 6 dots. The DLI handles fractional line spacing by rounding to the nearest dot, while retaining the ideal fractional dot position for subsequent line-space calculations.

As dot rows in the strip buffer are printed, the DLI examines the next object in its list and determines when the strip buffer has advanced far enough down the logical page to encompass the next object inside the limits of the strip buffer. The whole process operates in step with the print engine.

As shown in the figure, the physical bit image never exceeds the size of the strip buffer, even though the logical bit image (written to the print engine) spans a full page. In this way, the use of a strip buffer ensures a low memory requirement.

While the full-page bit-map design is required for truly unlimited page complexity, the strip-buffer design can handle most applications. Furthermore, the strip-buffer design can be modified to accommodate more demanding graphics. As printer resolution increases, the strip-buffer approach may be an essential element in keeping printer costs down. ■

Recent PC
announcements
have left
Compaq
in an
enviable
position.

Compaq still

In the midst of the clamor surrounding the new IBM® PS/2 personal computers, one thing is perfectly clear to people who really know PC's. COMPAQ® personal computers still work better. They enhance your productivity *within* the industry standard, and give you maximum performance from the world's largest library of business software.

different storage devices on all COMPAQ desktops.

Examine compatibility. We let you use all the industry-standard software and expansion boards that you already own.



Demand for the 12-MHz COMPAQ DESKPRO 286 has nearly doubled since the PS/2 introduction.

Still the performance leader

COMPAQ personal computers prove superior in overall performance.

Take speed. The COMPAQ DESKPRO 286® runs your software up to 20% faster than its PS/2™ counterpart. And, the COMPAQ DESKPRO 386™ sets all records for speed in advanced-technology, industry-standard personal computers.

Consider flexibility. Compaq offers 5¼" diskette drives, and allows you to add 3½" drives. In fact, you can add up to four

Look at expandability. Our industry-standard slots enable you to add many extra functions. So you can configure your system exactly the way you want it.

Finally, compare portability. You can't. The 12-MHz 80286-based COMPAQ PORTABLE III™ is the undisputed leader. It offers the

performance of a desktop without any of the compromises you'll find

in other portables.

Compaq applies innovative technology within the industry standard, *without* sacrificing compatibility.

Earn higher returns on your investment

American business has \$80 billion invested in

The 12-MHz COMPAQ PORTABLE III is the smallest, most powerful full-function portable there is.

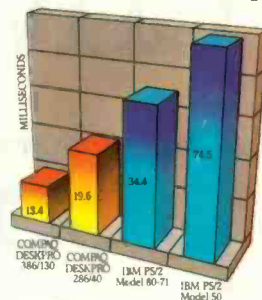

COMPAQ fixed disk drives can access data up to 2½ times faster than PS/2 drives.

It still simply works better.

works better.

Two-way compatibility

Compaq has become famous for its legendary compatibility and connectivity. Our personal computers will run thousands of pro-

grams, without modification, far faster than other computers. And they work with all the other compatible computers in your office, without time-consuming diskette conversions.

We don't burn bridges, we build them

At Compaq, advances are measured by our ability to push technology forward, without leaving you behind.

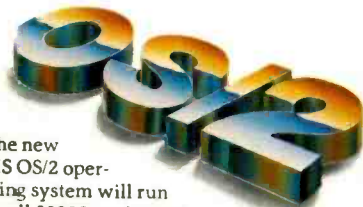

The new MS OS/2 operating system will run on all 80286- and 80386-based COMPAQ personal computers.

The COMPAQ DESKPRO 386 sets the standard for high-performance, advanced-technology desktop computing.

grams, without modification, far faster than other computers. And they work with all the other compatible computers in your office, without time-consuming diskette conversions.

As for the future, all 80286- and 80386-powered COMPAQ personal computers will run the new MS OS/2 operating system, allowing you to directly access up to 16 mega-

COMPAQ computers let you incorporate developing technology, and take advantage of the latest technology in a way that's fully compatible with the hardware, software and add-ons you already own. So Compaq protects your investment.

These are all reasons why recent surveys show COMPAQ owners are the most satisfied personal computer users.

Call 1-800-231-0900, operator 39, for information and the location of your nearest Authorized COMPAQ Computer Dealer. In Canada, call 416-449-8741.

the current PC standard, including 72 million software and hardware products, and hundreds of millions of hours in training.

Compaq designs its computers to protect your investment. And because they do more, they also maximize it.

COMPAQ[®]

This printer is planning a corporate takeover. The 24-pin C-815 Supra.

In the fast-paced world of corporate computing, one printer has been voted most likely to succeed.

The new 24-pin ProWriter C-815 Supra. From C. Itoh Digital Products. **Supra power.**

With its 8086 microprocessor, one megabit ROM and 64K RAM, the C-815 is the only printer that will match the power and speed of your PC for the demanding high-volume, multi-user environment of today's corporate departments.

For starters, it's one of the fastest 24-pin dot matrix printers on the market today. And at 53 dBA in normal mode and 51 dBA in quiet mode, it's also the quietest.

The unique diamond configuration of the Supra's 24-pin printhead allows the printer to race through drafts up to 570 characters per second, or attention-getting true letter quality proposals at an incomparable 162 cps (12 cpi) — over 60% faster than the Toshiba P351®

Many users? One printer.

The Supra is the printer to have at LAN's end. Because with its massive 42K buffer, there's no more waiting in

line for important documents. And with built-in emulations for the IBM ProPrinter XL®, Toshiba P351 and Qume Sprint 11,® and parallel/serial interfaces, it will run



with just about any system or software in your department.

Functions follow forms.

If multi-part forms are an important part of your business, nothing beats the Supra. In its Copy + mode, it will handle up to six copies — a third more than the competition. What's more, the Supra features advanced paper-handling like top, bottom and rear feed and a pull-type tractor standard. A bi-directional tractor and single- and dual-bin sheet feeders are also available.

Intelligent features include a handy Clear Buffer mode that automatically clears the buffer without turning off the printer. A unique Top of Form sensor also saves paper by actually overriding the software and not advancing to the next page, unless it's necessary.

Presentation graphics.

The Supra also prints bidirectional business graphics up to 180 x 360 dots per inch, including true circles (instead of ovals you get from other 24-pin printers). For eye-catching headings, users can also magnify characters up to eight times, horizontally and vertically.

With optional font cards, you can express yourself in a variety of typestyles. You can even create and permanently store your own typeface or logo using C. Itoh's optional download card and Font Master® software.

Corporate conqueror.

The new C. Itoh C-815 Supra is one of the fastest, quietest dot matrix printers on the market today. It's a master of capabilities that line and laser printers can't touch. And it's backed nationwide by C. Itoh Digital Products' one-year warranty.



The takeover has begun. Ask to see a Supra today.

Upgrade.



C. ITOH

C. Itoh Digital Products, Inc.

19300 South Hamilton Avenue • Suite 110
P.O. Box 9085, Torrance, California 90508
Telephone: (213) 327-2110 or (800) 423-0300

Toshiba P351 is a registered trademark of Toshiba America, Inc. IBM ProPrinter is a registered trademark of International Business Machines Corporation. Qume 11 is a registered trademark of Qume Corporation.

**Inquiry 70 for End-Users.
Inquiry 71 for DEALERS ONLY.**

Reviews

Reviewer's Notebook	236
<i>by Cathryn Baskin</i>	
The Kaypro 386	239
<i>by Ray Duncan</i>	
Mail-Order Performance	245
<i>by Frederick D. Davis</i>	
The NEC MultiSpeed	253
<i>by David Satz</i>	
The Micro Clipper Graphics Subsystem	257
<i>by Charles Weston</i>	
PC-MOS/386	263
<i>by Richard Grehan</i>	
Actor 1.0	266
<i>by Leonard Moskowitz</i>	
ALS Prolog	269
<i>by Alex Lane</i>	
Benchmarking dBASE III Plus Compilers	277
<i>by Malcolm C. Rubel</i>	
DESQview 2.00	281
<i>by John McCormick</i>	

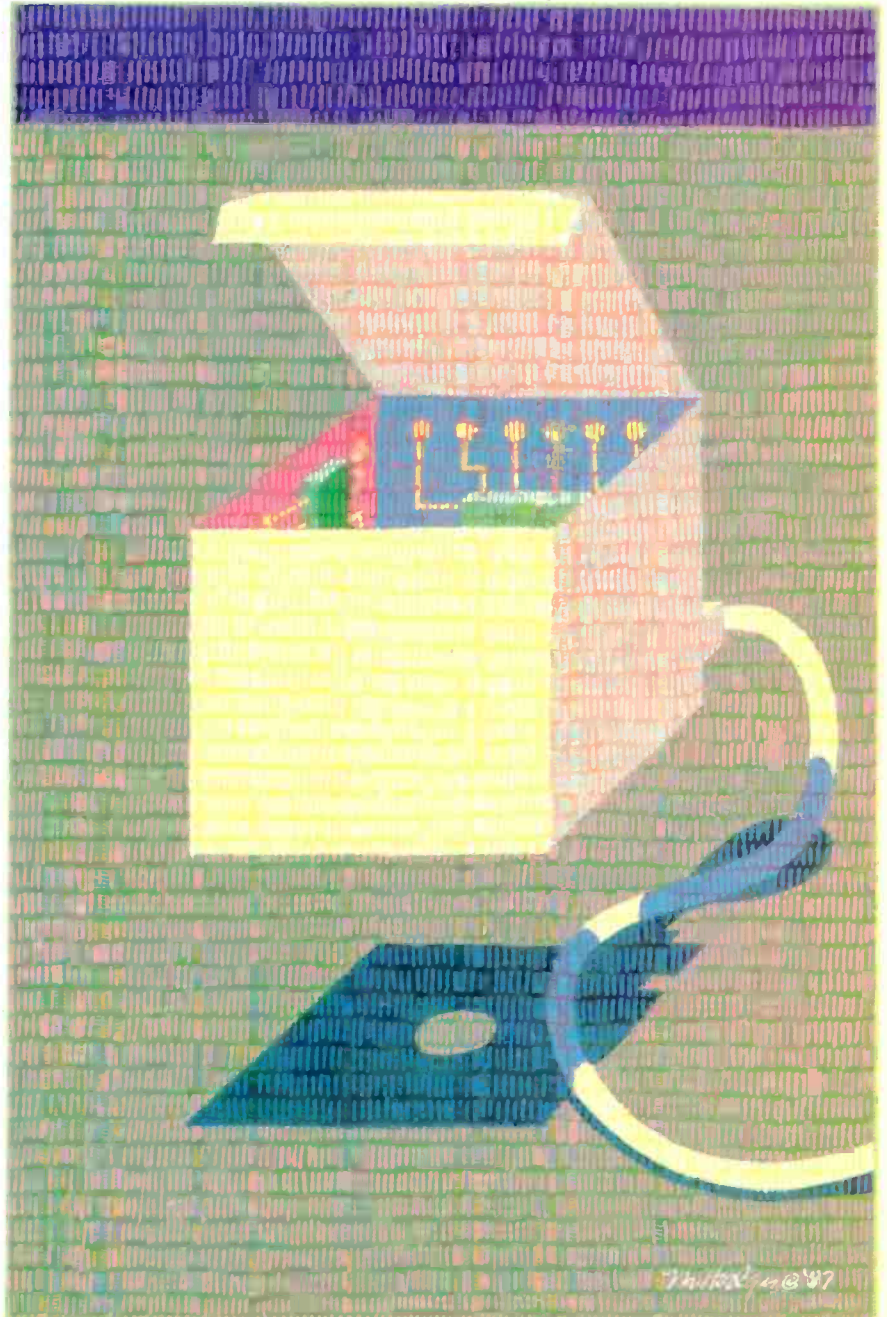

REVIEWER'S NOTEBOOK

On page 110 in this issue, you'll see comparative benchmarks for a variety of 80386 and 68020 systems. Take a look at the results achieved by Definicon Systems' DSI-780 coprocessor board. This board and its compiler, which we installed in an 8-megahertz IBM PC AT, turned in a performance better than that of any of the other 68000 and 68020 systems and compilers we tested, including the Arete. In half of the tests—the Fibonacci, Savage, and Sieve—the DSI board outperformed the Compaq Deskpro 386 and the IBM PS/2 Model 80.

The price you pay for this performance is \$3295, which gets you the DSI-780 with 16-MHz 68020 and 68881 microprocessors and 4 megabytes of RAM. Look for a full review of this board in the October issue. Definicon also sells other models, including the DSI-780+, which runs at 20 MHz and can hold up to 16 megabytes of RAM. With 1 megabyte, the DSI-780+ costs \$2295; with 4 megabytes, \$3595. You can contact Definicon Systems at 1100 Business Center Circle, Newbury Park, CA 91320, (805) 499-0652.

This month, beta versions of Microsoft's new Quick C and C 5.0 compilers arrived in our offices. BIX senior editor David Betz, who reported on Borland's Turbo C last month, offers his early impressions of both Microsoft compilers below.

—Cathryn Baskin
Senior Technical Editor, Reviews

Like Borland's Turbo C, Microsoft's Quick C (\$99) is a fast integrated C devel-

opment environment for IBM PCs, ATs, and true compatibles. Quick C provides a compiler, linker, editor, make facility, and source-level debugger, all within a single integrated environment.

For programmers who aren't comfortable with an integrated environment, Quick C also provides a command-line interface, as well as a stand-alone make facility, linker, and object-module librarian. Quick C supports four different memory models (small, medium, compact, and large) and mixing of models through the command-line interface. The integrated environment always uses the medium memory model.

The copy of Quick C I looked at was a beta release that I couldn't benchmark for either compile speed or execution speed. I was able to compile and run the same code that I used to benchmark the Turbo C compiler last month, but because the integrated environment supports only the medium memory model, I was unable to compare the results directly with those from Turbo C.

Running a program within the Quick C integrated environment causes an executable file to be created in the current directory. Unlike with Turbo C, this file can't be used outside the Quick C environment. The separate option that allows stand-alone programs to be built can be somewhat confusing because you can't run the stand-alone programs from inside the environment, and the programs generated to run in the environment can't be run as stand-alone programs.

The main advantages of Quick C over Turbo C are its source-level debugger and

compatibility with Microsoft C. Both products provide an easy-to-use user interface and a command-line interface for experienced programmers. Both are fast compilers that provide quick turnaround time for the edit/compile/link/execute cycle.

Microsoft will sell Quick C both alone and as part of the new C version 5.0 compiler (\$450). To compare version 5.0 with 4.0, I used the beta version of 5.0 that I received to run some of BYTE's standard benchmark programs (see table 1) on a Compaq Portable 286 with an 8-MHz 80286. To get an idea of how using the large memory model slows down program execution, I ran the Dhrystone with both the large and small memory models. I ran the remaining benchmarks with only the small memory model, and I ran each test with and without optimization. For the optimized versions, I used the compiler's `-ox` switch to get the highest level of optimization. For the unoptimized versions, I used the `-od` switch to disable all optimizations.

Using optimization caused some rather strange problems with some of the benchmarks. For instance, the Float benchmark consists of a series of floating-point operations whose values aren't used for anything. With optimization enabled, Microsoft C 5.0 recognized that the results weren't going to be used and eliminated all the computations. This kind of "dead code" elimination is good for a real application but invalidates benchmarks like this implementation of the Float test.

Quick C runs on the IBM PC and compatibles with 384K bytes of memory, MS-DOS 2.0 or higher, and one double-sided floppy disk drive. Microsoft C 5.0 will run on the IBM PC and compatibles with 384K bytes of RAM, MS-DOS 2.0 or higher, and a hard disk drive. For more information, contact Microsoft Corp., 16011 Northeast 36th Way, P.O. Box 97017, Redmond, WA 98073-9717, (800) 426-9400 or (206) 882-8088.

(Note: In July, I mentioned that Turbo C had a bug that prevented large-model programs from linking correctly. Borland has provided a fix for the problem that will be made available to any current owner of Turbo C on request.)

—David Betz
Senior Editor, BIX

Table 1: Benchmark results for Microsoft C 4.0 and the beta version of 5.0. `-ox` tests were run with the highest level of optimization; `-od` tests were run with no optimization. Numbers in parentheses indicate how many iterations were performed. All times are in seconds.

	5.0 (-ox)	5.0 (-od)	4.0 (-ox)	4.0 (-od)
Sieve (10)	1.63	3.30	2.78	4.14
Sort (10)	3.79	5.33	4.25	5.35
Fib (10)	11.73	22.96	12.85	23.14
Float	0.00	75.63	45.75	76.16
Savage (2500)	53.08	56.44	59.48	59.48
Dhrystone (small model)	2081.00	1261.00	1666.00	1209.00
Dhrystone (large model)	1630.00	1000.00	1363.00	986.00

GENICOM LASER PRINTERS



A classic combination of performance and value

Presenting the Genicom Laser Classics. Two laser printers that offer full Hewlett-Packard® LaserJet Plus emulation for today's growing desktop publishing applications. Plus a great deal more.

The first value in laser printing.

Searching for the most sensible laser printer for your personal computer? The PagePrinter 8 is the answer. It features the lowest consumables cost of any 8 page per minute laser, just 2.7 cents per page.

Now, add in a 300,000 page printer life. And more features than any laser in its price range. It's easy to see what makes the PagePrinter 8 a value leader.

The last word in laser printing.

If your business is ready for a reliable, high volume workhorse, you're ready for the Genicom 5010.

The 5010's full feature control panel puts the world of laser printing at your fingertips. Print everything from letters and legal size paper to transparencies in seconds. Select fonts and switch between portrait and landscape at the push of a button.

There's even a 32 character LCD performance and diagnostic readout that communicates in plain English.

The 5010 and the PagePrinter 8 from Genicom. Two classic examples of better laser printers for your money. For more information, call 1-800-4-GENICOM. In VA, 1-703-949-1170.

PagePrinter 8

Emulations: HP Laser Jet Plus, IBM® Graphics Printer, IBM Proprinter, Diablo® 630/630 ECS, Epson® FX-80

Speed: 8 pages per minute

Paper Handling: 100 in, 100 out uncollated

Genicom 5010

HP LaserJet Plus, IBM Graphics Printer, Diablo 630

10 pages per minute

200 in, 200 out collated, dual input trays, optional 50 sheet cassette

GENICOM

The Printers That Mean Business.
Genicom Drive, Waynesboro, VA 22980

PURCHASE TOMORROW'S OPERATING SYSTEM TODAY

WENDIN-DOS^{T.M.}

THE MULTITASKING, MULTIUSER MS-DOS REPLACEMENT

- RUNS ON ANY IBM-PC, XT, AT, 80386, OR TRUE COMPATIBLE
- RUNS MS-DOS PROGRAMS AND USES THE MS-DOS FILE SYSTEM
- FEATURES FILE SHARING AND FILE LOCKING
- PROVIDES TRUE CONCURRENT MULTITASKING AND TASK SWITCHING
- SUPPORTS MULTIPLE TERMINALS WITH NO EXTRA SOFTWARE NEEDED
- FEATURES A USER-CONFIGURABLE WINDOWING INTERFACE
- ALLOWS ADDRESSING OF EXTENDED MEMORY
- FEATURES A FILE PERMISSION SYSTEM
- SUPPORTS THE MS-DOS COMMAND LANGUAGE AND THEN EXTENDS IT WITH COMMANDS LIKE PROTECT, PRIV, SPAWN, AND KILL

ONLY \$99 diskettes and manual included **FROM WENDIN**, of course.

Don't Wait for OS/2!
Order Wendin-DOS today!!

TO ORDER CALL (509) 624-8088

And don't forget, Developers, to also order the Wendin-DOS Application Developer's Kit — The kit that gives you access to over 80 system services supported by Wendin-DOS — ONLY \$99. After all, you can't develop tomorrow's applications with yesterday's DOS.

SIMPLY SEND A BRIEF, WRITTEN REQUEST FOR INFORMATION ABOUT ANY WENDIN PRODUCT TO:

PLATINUM SERIES — WENDIN, INC.
FLEXIBLE DISKETTES P.O. Box 3888
Spokane, WA 99220-3888



We will send you an exciting full color catalog and a FREE product line demo diskette, while supplies last, compliments of Syncom Technologies, Inc., and Wendin, Inc. (509) 624-8088.

(System hardware recommendation — minimum 512K machine with at least the computing power of an IBM-AT.)



BOX 3888
SPOKANE, WA 99220-3888
Working beyond the horizon to develop the operating systems of tomorrow
© Copyright 1987 Wendin, Inc. (509) 624-8088

MS is a trademark of Microsoft.

Wendin is a registered trademark of Wendin, Inc.
Wendin-DOS and Wendin-DOS Application
Developers Kit are trademarks of Wendin, Inc.

DEALER INQUIRIES WELCOME
Foreign orders inquire about shipping.
Domestic orders add \$6.00/ 1st item, \$1.00
each additional item for shipping, handling, and
insurance. We accept Visa/MC, American
Express, C.O.D., and Bank Drafts drawn on
U.S. Banks.
Washington residents add 7.8% sales tax.



The Kaypro 386

Ray Duncan

*A solid contender
in the high-performance PC AT-
compatible arena*

The Kaypro 386 is an entrant in the newly emerging class of high-performance IBM PC AT compatibles. These machines have the general architecture of a PC AT but are based on an Intel 80386 32-bit microprocessor. In addition to a normal PC AT-compatible expansion bus, they also have a nonstandard 32-bit memory bus for increased performance.

The Kaypro 386's exterior appearance is similar to that of a PC AT, with the keylock, 1.2-megabyte floppy disk drive, disk- and power-indicator lights, connectors, and power switch all in their familiar locations. The computer is currently available in two models. The Model A (\$4495) comes with 512K bytes of RAM and no hard disk drive. The Model E comes with 2.5 megabytes of RAM and either a 40- or a 130-megabyte hard disk drive. The two configurations sell for \$5795 and \$8095, respectively. At the time of this writing, Kaypro announced that an additional model, the Model N, was expected to begin shipping this summer. It is intended for use as a network server, and it comes with 2.5 megabytes of RAM and either a 240- or a 330-megabyte hard disk drive. Prices for the two configurations are \$14,450 and \$19,450, respectively.

Standard equipment on the Model A and Model E includes a real-time clock, a parallel port, a serial port, a combination floppy disk and hard disk controller board that can handle up to two floppy disk drives and two hard disk drives, and a 102-key keyboard that is similar to the IBM 101-key enhanced keyboard, with 12 function keys across the top, a separate numeric keypad, and arrow and paging keys. The case has room for up to five half-height storage devices. The power supply is switch-selectable between 110

and 220 volts and is rated at 215 watts.

All three models of the Kaypro 386 use the same motherboard, the Intel iSBC 386 AT, which has a 16-MHz 80386 microprocessor and 512K bytes of 120-nanosecond RAM. [Editor's note: *The motherboard is similar in design to the ALR Access 386's motherboard, another Intel-derived design. For more information, see "The ALR Access 386 and the Compaq Deskpro 386" by Stanley J. Wszola and Curtis Franklin Jr. in the February BYTE.*] You can slow down the Kaypro 386's microprocessor to the equivalent of 6 MHz under software control (by inserting wait states) or by entering a special key sequence for use with timing-dependent programs. For expansion, the machine has two 8-bit IBM PC-compatible slots and four 16-bit PC AT-compatible slots, as well as two 32-

bit slots that can accept either 8-bit boards or special 2-megabyte 16-bit memory-expansion boards built by Intel and available from Kaypro for \$665; 8-megabyte boards may be available in the future. One of the Kaypro 386's 16-bit slots is occupied by the disk-controller card.

The expansion bus runs at 6 MHz for compatibility with older boards, except for the two 32-bit slots, which you can configure with jumpers on the motherboard to make them run at 16 MHz when 32-bit memory cards are present. A 68-pin grid-array (PGA) socket is present on the motherboard for installation of a 16-MHz 80387 numeric coprocessor (not yet available from Kaypro) or an Intel Math Coprocessor Module piggyback board (\$495), which adapts a 10-MHz 80287 40-pin DIP chip with some support circuitry to the 80387 PGA socket.

Two video display adapters are available as options for the Kaypro 386. One is the Kaypro Multi-Video Board, which can emulate the IBM Monochrome Adapter, the IBM Color Graphics Adapter, or the Hercules Monochrome Graphics Card. The other is the Kaypro Enhanced Graphics Adapter, which is based on the Chips and Technologies four-chip EGA set. Two optional monitors are available for the Kaypro 386: a 12-inch monochrome monitor and a 14-inch enhanced graphics monitor.

continued

Ray Duncan is a software developer for Laboratory Microsystems Inc. (3007 Washington Blvd., Suite 230, Marina del Rey, CA 90292) and author of Advanced MS-DOS: The Microsoft Guide for Assembly Language and C Programmers (Microsoft Press, 1986).



Kaypro 386

Company

Kaypro Corp.
533 Stevens Ave.
Solana Beach, CA 92075
(619) 481-3900

Size

21¼ by 16½ by 6½ inches; 42 pounds

Components

Processor: 32-bit Intel 80386 running at 16 MHz, switchable to 6 MHz; socket for Intel 80387 numeric coprocessor
Memory: 512K bytes on system board; optional 2-megabyte Intel MEM020 plug-in expansion board, expandable to 16 megabytes
Mass storage: One 1.2-megabyte high-density floppy disk drive (all models) and one 40- or 130-megabyte hard disk drive (Model E) or one 240- or 330-megabyte hard disk drive (Model N)
Keyboard: 102 keys; 12 function keys
I/O interfaces: Eight slots: two 8-bit IBM PC compatible; four 16-bit PC AT compatible; two 32-bit slots for special Intel MEM020 memory boards; one serial port with DB-9 connector; one parallel port with DB-25 connector

Software

Microsoft MS-DOS 3.21; GWBASIC 3.20; Quarterdeck Office Systems' QEMM-386 1.0; Storage Dimensions' SpeedStor hard disk utility package

Options

2-megabyte 16-bit memory-expansion board: \$665
2-megabyte 32-bit memory-expansion board: \$1145
Kaypro Multi-Video Board: \$210
Kaypro Enhanced Graphics Adapter: \$295
12-inch monochrome monitor: \$145
14-inch enhanced graphics monitor: \$595
360K-byte floppy disk drive: \$145
40-megabyte hard disk drive: \$1398
80-megabyte hard disk drive: \$1750
133-megabyte hard disk drive: \$3595
Kaypro 386 Technical Manual: \$125

Documentation

160-page *Kaypro 386 User's Guide*; 500-page *MS-DOS 3.2 User's Guide and Reference Manual*; 310-page *GWBASIC 3.1 Interpreter Manual*; 64-page SpeedStor operations booklet; 8-page QEMM-386 brochure

Price

Model A (does not include a hard disk drive): \$4495
Model E (with 40-megabyte hard disk drive): \$5795
Model E (with 130-megabyte hard disk drive): \$8095

DISK ACCESS IN BASIC (IN SECONDS)

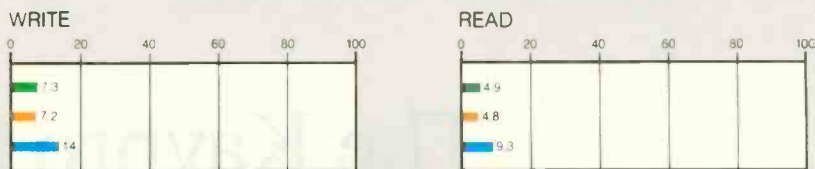

BASIC PERFORMANCE (IN SECONDS)



SYSTEM UTILITIES (IN SECONDS)

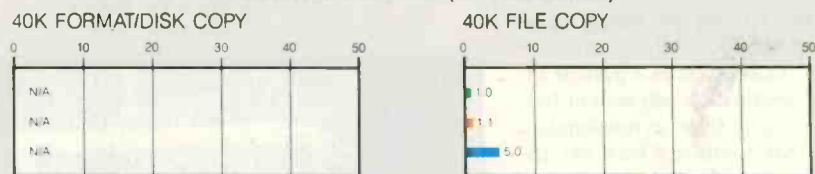

SPREADSHEET (IN SECONDS)



■ KAYPRO 386 ■ DESKPRO 386 ■ IBM PC AT (8 MHz)

The graphs for Disk Access in BASIC show how long it takes to write and then read a 64K-byte sequential text file to a hard disk. The Sieve graph shows how long it takes to run one iteration of the Sieve of Eratosthenes prime-number benchmark. The Calculations graph shows how long it takes to perform 10,000 multiplication and 10,000 division operations using single-precision numbers. The 40K Format/Disk Copy benchmark was not performed because the computers had only one floppy disk drive. The 40K File Copy graph shows how long it takes to copy a 40K-byte file from one location on the hard disk to another. The Spreadsheet benchmarks show how long it takes to load and recalculate a 100-row by 25-column spreadsheet in which each cell equals 1.001 times the cell to its left. (For the program listings, see *BYTE's Inside the IBM PCs*, Fall 1985, page 195.) All benchmark tests were run without any extended memory management, hard disk-driver, or disk-caching programs. Tests on the Kaypro 386 were done with MS-DOS 3.21 and GWBASIC 3.20; tests on the Compaq Deskpro 386 were done using Compaq DOS 3.1 and Compaq BASIC 3.11; and tests on the IBM PC AT were done with PC-DOS 3.2 and BASICA 3.2. All spreadsheet benchmarks were done using Multiplan 1.06.

Other options include additional 1.2-megabyte and 360K-byte floppy disk drives; 40-, 80-, and 133-megabyte hard disk drives; and internal and external 60-megabyte tape-backup units.

My review unit was a Model E with 2.5 megabytes of RAM, a Kaypro Enhanced Graphics Adapter and monitor, a 1.2-megabyte floppy disk drive, and a Priam ID40 42-megabyte hard disk drive with a rotary voice-coil head positioner and a claimed 30-millisecond average access time. The CORE International Coretest Disk Performance Test program recorded a data-transfer rate of 164K bytes per second, an average seek time of 24.8 ms, and a track-to-track seek time of 4.4 ms for the Kaypro 386's hard disk system. The disk-controller card uses Western Digital chips.

Essential Software

The Kaypro 386 comes with Microsoft MS-DOS 3.21 and GWBASIC 3.20. In addition, the computer comes with a set-up program for system configuration that is easy to use; Quarterdeck Office Systems' Expanded Memory Manager (QEMM-386) 1.0, which allows you to configure extended memory above 1 megabyte according to the Lotus/Intel/Microsoft Expanded Memory Specification (EMS); and Storage Dimensions' SpeedStor 4.02a hard disk utility package. SpeedStor includes the HARDPREP and PARTED programs, which are used to format and partition the hard disk, and HARDRIVE.SYS, an installable device driver that configures the partitions of a larger-than-32-megabyte hard disk drive for use as multiple logical volumes.

The Printed Word

The *Kaypro 386 User's Guide* describes the standard features and options of the computer's various models, unpacking and setting up the system, and configuration of the system for various options. It also covers the keyboard and use of the editing keys, some introductory material on MS-DOS commands and management of files, and instructions for using some of the Kaypro utility programs. Appendixes include an MS-DOS bibliography, a table of the extended character set, and charts of the system board jumpers and the pin-outs of the various connectors.

Also included with the Kaypro 386 are an *MS-DOS 3.2 User's Guide and Reference Manual* and a *GWBASIC 3.1 Interpreter Manual*. In addition, the Kaypro 386 comes with an 8-page glossy brochure about Quarterdeck's QEMM-386 1.0, which contains installation and operating instructions and a license and disclaimer of liability. The SpeedStor disk comes with a 64-page instruction booklet

from Storage Dimensions.

My review unit also came with an 84-page preliminary copy of the *Kaypro 386 Technical Manual*. This book contains some general descriptive material and a block diagram and jumper settings for the system board, pin-outs for the various connectors and power supply, a list of the interrupt numbers assigned to the BIOS functions and hardware controllers, and a fairly detailed summary of the disk controller's registers and commands. The preliminary manual has no schematics or BIOS listings.

Compatibility

To evaluate the Kaypro 386's hardware compatibility with the IBM PC and PC AT, I loaded the machine with various combinations of expansion boards, including Hercules and Vega EGA video adapters, an Intel Above Board/AT with 2 megabytes of RAM, a 3COM Etherlink network card, a Microsoft Mouse (bus version), a Hayes-compatible 1200-bit-per-second internal modem, and a Hitachi CDR-1502S CD-ROM drive and adapter. The Kaypro 386 worked flawlessly with all these boards.

To assess the machine's software compatibility, I tried running a broad variety of popular application packages, utilities, and programming tools on it. The software I tested included Morgan Computing's Trace86 debugger 2.00, Microsoft's SYMDEB 4.00 and CodeView 1.11 debuggers, Chris Dunford's ProCED command-line editor 1.02L, Datastorm's ProComm 2.4.2 (a telecommunications program), Revolution Software's Cruise Control 2.15 (a keyboard enhancer), Microsoft Word 3.1, MicroPro's WordStar 3.30, Microsoft Windows 1.03, Fifth Generation Systems' Fastback 5.13, Laboratory Microsystems' UR/Forth 1.01, Microrim's R:BASE System V 1.1, Quarterdeck's DESQview 1.3, and Lotus 1-2-3 2.0.

The only program that did not work as expected at 16 MHz was Lotus 1-2-3, which did not recognize its key disk. When I slowed the processor to 6 MHz by pressing Control-Alt-1, the copy-protection scheme functioned properly and the program loaded. I then resumed 16-MHz operation with the Control-Alt-2 key sequence.

Reliability and Performance

I used the Kaypro 386 for one month on a daily basis in my office along with a Compaq Deskpro 386 on a local area network for normal programming and word-processing tasks. During this time, the machine proved completely reliable, and I encountered no problems.

The results of the BYTE benchmark

tests show that the hard disk access times for the Kaypro 386 and the Compaq Deskpro 386 are basically equivalent. The floppy disk access times varied, with the results slightly favoring the Kaypro 386. This discrepancy may be because the Deskpro 386 automatically slows down to 8 MHz when accessing a floppy drive to provide automatic compatibility with most copy-protection schemes.

The BASIC Sieve and Calculations benchmarks and the Spreadsheet Recalculate test demonstrate a consistent 7 percent to 10 percent advantage in execution speed for the Deskpro 386. Since the microprocessor in both machines runs at 16 MHz, the speed difference seems to be due to the Deskpro 386's static memory chips and the more sophisticated 32-bit memory bus's access to those chips, in contrast to the Kaypro 386's dynamic RAM board.

I ran all the benchmark tests with no programs running in the background and with the extended memory management program, QEMM.SYS, and the program for use with the 40-megabyte hard disk drive, HARDRIVE.SYS, disabled. Thus, the benchmark results in the graph on page 240 reflect the performance of the raw hardware.

I tested these two 80386 machines further by writing two highly optimized assembly language implementations of the Sieve of Eratosthenes algorithm popularized by Jim Gilbreath. [Editor's note: *For more information, see "Eratosthenes Revisited: Once More through the Sieve" by Jim and Gary Gilbreath in the January 1983 BYTE. The listings are available on disk, in print, and on BIX. See the insert card following page 256 for details. Listings are also available on BYTEnet. See page 4.*]

The first implementation, SIEVE86, uses only 8086 instructions and can run on the Intel 8086/8088 or 80286/80386 microprocessors in real mode (i.e., the 8086 emulation mode used by these processors when running MS-DOS). I assembled and linked SIEVE86 into an .EXE file with the Microsoft Macro Assembler (MASM) and the Microsoft Object Linker, respectively. The second implementation, SIEVE386, uses the 80386's 32-bit registers and operations throughout. I assembled, linked, and debugged the program with Phar Lap's 386|ASM, 386|LINK, and MINIBUG 80386 programming tools. I then ran it for timing purposes under the control of the Phar Lap 386|DOS-Extender, which provides a 32-bit protected-mode runtime environment for programs. The 386|DOS-Extender tool loads a 32-bit application into extended memory (above

continued

the 1-megabyte boundary) for execution, leaving lower memory undisturbed and switching back to real mode as needed to perform MS-DOS function calls.

The Kaypro 386 ran the SIEVE86 and SIEVE386 programs in 48 and 56 seconds, respectively, while the Compaq Deskpro 386 ran each of the programs in 41 seconds. This confirms the Kaypro 386's significantly slower throughput in the BASIC benchmarks and demonstrates that the Kaypro's extended memory is slower than its conventional memory. This finding contradicts the statement in

the *Kaypro 386 Technical Manual*, which says that the access times to memory on cards in the 32-bit expansion slots are the same as the access times to the 512K bytes of RAM on the motherboard. When I called the company, Kaypro admitted that the access times for the 32-bit memory board are slower. [Editor's note: *The reason for the slowness of the memory board is that the memory is organized into two banks of 1 megabyte each, with one bank containing the even addresses and the other containing the odd addresses. Accessing successive odd and even*

addresses will usually cause one wait state per access.]

Picking Some Nits

The Kaypro 386 has some flaws, particularly when compared to the Compaq Deskpro 386. For example, the various option jumpers on the motherboard are spread from one end to the other instead of being centralized in one location as they are in the Deskpro 386. Similarly, the socket for the 80387 in the Kaypro 386 is buried under the edges of the hard disk drive and power supply in such a manner that it would be nearly impossible to add a numeric coprocessor chip or module without disassembling the computer.

The portions of the documentation that originate with Kaypro (i.e., the *Kaypro 386 User's Guide* and *Kaypro 386 Technical Manual*) are barely adequate. The user's guide is poorly organized, inconsistent, and often omits important information or provides information that is inaccurate or misleading. For instance, the key sequence to increase the volume of the key clicks is not documented; I discovered it to be Control-Alt-+ by trial and error. The procedure for making the hard disk bootable is located in Chapter 2 under "Hardware Installation," while the section in Chapter 3 entitled "Loading MS-DOS onto the Hard Disk" describes only how to copy MS-DOS files from the distribution floppies to drive C. The entire "Getting Started" section is oriented toward floppy disk-based systems, even though the typical 80386 system is hard disk-based. The page entitled "Redirecting Screens" discusses redirection of the standard output device; redirection of the standard input device is not mentioned at all.

Final Thoughts

The Kaypro 386 is a reliable personal computer that delivers two to three times the performance of the IBM PC AT. Its compatibility with standard 8086- and 80286-based PCs and software is excellent. Its performance is similar to that of the Compaq Deskpro 386. The deficiencies in its documentation and other minor inconveniences, such as the position of the jumpers on the motherboard and the layout of the keyboard, will be no great obstacles to experienced users.

If you need to run software applications at the fastest possible speed, or if you are prototyping 80386 software, the Kaypro 386 is perfectly suitable. As a slightly more economical alternative to the Compaq Deskpro 386, whether for software development or for crunching data, the Kaypro 386 appears to be a good buy. ■

MIRROR II™

WIBBLES II

THE BETTER CROSSTALK®

UPGRADE WITH THE

MONEY-BACK GUARANTEE!

Compare Before You Buy or Upgrade!

	\$245.00 Crosstalk Mk. 4	\$195.00 Crosstalk XVI	\$69.95 MIRROR II
Crosstalk XVI Compatibility	●	●	●
Features	●	○	●
Background Communications	—	—	●
Integrated Text Editor	●	—	●
Auto-Learn Mode	●	—	●
Site Licensing	—	—	●
60-Day Money-Back Guarantee	—	—	●

LEGEND: — Not Supported ○ Fair ● Good ● Better ● Best

\$20.00 Discount Exclusively For Owners of Crosstalk XVI®

If you own a copy of Crosstalk XVI and purchase a copy of MIRROR II from SoftKlone, we will give you a \$20.00 discount. In order to qualify, follow these simple steps when ordering by telephone or mail: provide us with your Crosstalk XVI serial number along with payment of \$49.95 plus \$3.00 for shipping and handling (\$8.00 for COD). Payment may be made by check, VISA, MasterCard or COD. Offer Expires November 30, 1987.

60-DAYS RISK FREE

Don't let their "New Flagship" leave you at the dock. Try MIRROR II for 60-Days, RISK FREE! Why sacrifice Crosstalk XVI compatibility, with an expensive voyage on the "New Flagship" and no guarantee of Free Passage if you don't like the trip.

To order call Toll Free: 1-800-634-8670 (In Florida call: (904) 878-8564)

\$69.95

VISA MC COD

Shipping/Handling \$5.00 (COD add \$3.00)
Overseas Orders \$18.00
Florida Residents add 5% Sales Tax

A Better Reflection™

SOFTKLONE™

336 Office Plaza Drive
Tallahassee, Florida 32301
(904) 878-8564
Telex: 6714280 KLON

Crosstalk, Crosstalk XVI and Crosstalk Mk. 4 are registered trademarks of Digital Communications Associates, Inc. / MIRROR, MIRROR II and SoftKlone are trademarks of SoftKlone Distributing Corporation. MIRROR II is available for IBM and compatible systems running MS-DOS 2.0 or higher including the IBM PS/2. When ordering, please specify 3.5" or 5.25" disk format.

KOH-I-NOOR PLOTTER PENS

Koh-I-Noor, the leader in providing highest quality hard copy for technical drawing, now combines many years of experience and long-term association with plotter manufacturers to provide pens for the business professional. Koh-I-Noor Fiber Tip and Disposable Liquid Ink Plotter Pens provide the highest quality, brightest appearing output for use on overhead projections, chart papers and graphic papers for the most effective presentations.

Koh-I-Noor Fiber Tip Plotter Pens are available for the most popular plotters, including Hewlett Packard and Houston Instruments. They are offered in two

line widths with up to ten brilliant colors. The pens provide excellent contrast and fill-in for overhead projections, reports and graphs.

DPP®—Disposable Plotter Pen™ is also available for the most popular plotters, including the new "S" Style DPP, which is used on Hewlett Packard's tabletop and similar plotters with liquid-ink capability. The DPP provides the highest quality output on chart paper and uncoated presentation paper. Line quality does not deteriorate over time, and the ink in the cartridge is waterproof and fade resistant. The pens are available in four precise line

widths and in up to ten colors.

Both the Koh-I-Noor Fiber Tip Plotter Pen and the Disposable Plotter Pen are designed for the easiest possible use. No maintenance or cleaning. Once activated, they are immediately ready for use. When they run out of ink, just throw them away. Koh-I-Noor Plotter Pens—for the best possible hard copy. For more information, see your dealer or send the coupon.

KOH-I-NOOR
RAPIDOGRAPH®
 a rotring company

Inquiry 330

For the most effective presentations—
 overhead projections
 and report graphs.



Pens shown oversized

Show me more, Koh-I-Noor
 Please send me your free Plotter Supplies Catalog No. 4.

NAME (please print or type) _____

TITLE _____

FIRM _____

PLOTTER MAKE _____ MODEL _____

ADDRESS _____

CITY _____ STATE _____ ZIP _____ B-9/87

Koh-I-Noor Rapidograph, Inc., 100 North St., Bloomsbury, NJ 08804.
 In Canada: 1815 Meyerside Drive, Mississauga, Ontario L5T 1G3.

Osborne/McGraw-Hill's

Indispensable Complete Reference Series



◀ 1-2-3®: The Complete Reference

by Mary Campbell

Every Lotus® 1-2-3® command, function, and procedure is thoroughly explained and demonstrated in "real-world" business applications. Includes money-saving coupons for add-on products. 892 pages.

\$22.95, A Quality Paperback,
ISBN 0-07-881005-1

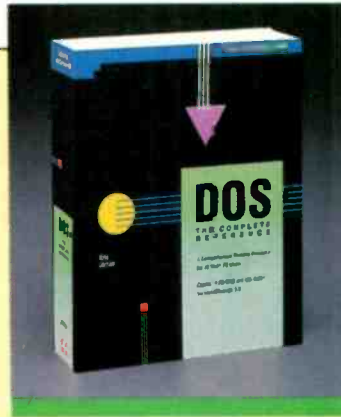

◀ DOS: The Complete Reference

by Kris Jamsa

Has all the answers to all your questions on DOS through version 3.X. This essential resource is for every PC-DOS and MS-DOS® user. 1045 pages.

\$24.95, A Quality Paperback,
ISBN 0-07-881259-3

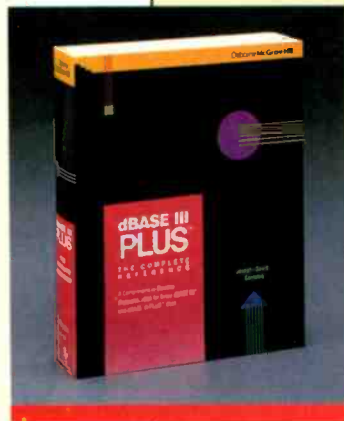

◀ dBASE III PLUS™: The Complete Reference

by Joseph-David Carrabis

Conveniently organized so you can quickly pinpoint all dBASE III® and dBASE III PLUS™ commands, functions, and features. 768 pages.

\$22.95, A Quality Paperback,
ISBN 0-07-881012-4

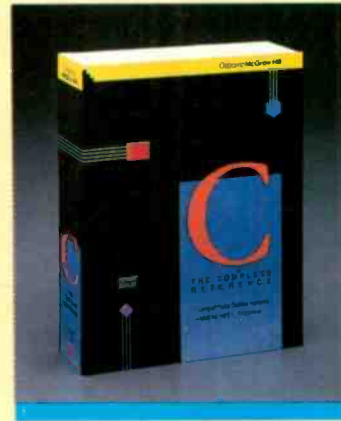

◀ C: The Complete Reference

by Herbert Schildt

For all C programmers, beginners and seasoned pros, here's an encyclopedia of C terms, functions, codes, and applications. Covers C++ and the proposed ANSI standard. 740 pages.

\$24.95, A Quality Paperback,
ISBN 0-07-881263-1



AVAILABLE NOW at Fine Book Stores and Computer Stores Everywhere.

Or Call Our Toll-Free Order Number **800-227-0900**
800-772-2531 (In California)

Available in Canada through McGraw-Hill Ryerson, Ltd. Phone 416-293-1911



Osborne **McGraw-Hill**

2600 Tenth Street
Berkeley, California 94710

Trademarks: Lotus and 1-2-3 are registered trademarks of Lotus Development Corp. dBASE is a registered trademark and dBASE III PLUS is a trademark of Ashton-Tate. MS-DOS is a registered trademark of Microsoft Corp.



Mail-Order Performance

Frederick D. Davis

Two high-speed PC AT compatibles with a catalog of options

The Proteus-286GT from Proteus Technology Corp. (\$2395) and the GV-286 from PC Designs (\$2920) offer a multitude of optional hard disks, monitors, display adapters, and keyboards. Although each improves on the performance of the IBM PC AT, each has a different way of doing so. As evidence of a growing trend, both of these 12-MHz dual-speed PC AT compatibles are available only by mail order from their respective companies.

Common Denominators

Because the Proteus-286GT and the GV-286 both have the same chassis, the computers look a lot alike, except for the front panels. The units I reviewed were both equipped with 30-megabyte Seagate ST4038 hard disk drives, each with a 40-millisecond average access time; 1 megabyte of 100-nanosecond RAM on the main board, 640K bytes below the 1-megabyte address and 384K bytes above; an EGA adapter based on the Chips and Technologies chip set; an NEC MultiSync monitor; and a 1.2-megabyte floppy disk drive. Both machines also had Western Digital disk controllers and were supplied with MS-DOS 3.2 and GWBASIC 3.2.

The chassis used for both machines is a sturdy 21¼- by 16½- by 6¼-inch steel case containing a 200-watt UL-approved 110/220-volt power supply. At the rear of the chassis are cutouts for three DB-25 connectors and two DB-9 connectors. These cutouts enable you to install up to five ports without taking up extra rear slot ends for connectors. The chassis incorporates five half-height drive slots with individual power and ground connectors and two floppy disk drive data connectors. The full-height hard disk



Proteus Technology's Proteus-286GT (left) and PC Designs' GV-286 (right).

drive occupies two of the five slots, and the 1.2-megabyte floppy disk drive takes up another slot.

The chassis also has a rear switched-power outlet for a monitor. This outlet is convenient, but it requires a plug with a special rectangular cross-section ground prong. The standard three-prong plug won't fit, and neither machine comes with an adapter.

Both computers have cylindrical vending machine-style locks for enabling and disabling their keyboards and retaining their covers. The motherboards of both systems have six 16-bit PC AT-compatible slots and two 8-bit PC-compatible slots. Neither motherboard has any visible rework on the top side. Unfortunately,

neither system filters its cooling air, and a heavy buildup of dust on high-performance chips can contribute to failure due to overheating.

Each machine I reviewed came with its own custom BIOS and two modes of operation: a high-speed microprocessor mode with a low-speed bus and a low-speed mode for both the bus and microprocessor. You can change speeds by internal switches or from the keyboard in MS-DOS by using special key combinations.

The Proteus-286GT

The Proteus-286GT has a 12.5-MHz Intel 80286 microprocessor that runs with one wait state. As an alternative, you can jumper-select either a 6-MHz or an 8-MHz clock rate with zero wait states. Under MS-DOS, you can select the microprocessor speed (but not the wait state) from the keyboard.

You select the wait-state condition via a jumper on the motherboard; however, the bus speed for both modes is 6 MHz to avoid problems with PC AT-compatible accessory boards. The computer has no fast slot for full-speed add-on memory boards; therefore, you must use the 6-MHz PC AT bus speed when you are using memory that is not on the motherboard. In addition, the Proteus-286GT has no indicator on the front panel to tell you when you are in high-speed mode.

The Proteus-286GT I reviewed had a 10-MHz 80287-10 math coprocessor installed and running at 10 MHz (a \$375 option). To accomplish this speed, the

continued

Frederick D. Davis (P.O. Box 427, Riverton, UT 84065) is a self-employed consultant and programmer/analyst.

SEPTEMBER 1987 • BYTE 245

iteration of the Sieve of Eratosthenes prime-number benchmark. The Calculations graph shows how long it takes to do 10,000 multiplication and 10,000 division operations using single-precision numbers. The 40K Format/Disk Copy benchmark was not performed because the computers had only one floppy disk drive. The 40K File Copy graph shows how long it takes to copy a 40K-byte file from the hard disk to the floppy disk using the system utilities. The Spreadsheet graphs show how long it takes to load and recalculate a 100-row by 25-column spreadsheet in which each cell equals 1.001 times the cell to its left. The spreadsheet used was Microsoft Multiplan 1.10.

drive, and two half-height floppy disk drive slots are on the front panel of the machine. Also on the front panel is a high-speed indicator light (next to the hard disk access light) and a reset button (located next to the vending machine-style lock).

The GV-286 comes with a 30-megabyte Seagate ST4038 hard disk drive, an

continued

SEPTEMBER 1987 • BYTE 247

80287 is mounted on a piggyback board with its own crystal. This setup outperforms a directly mounted 80287, which would have to run at the 6-MHz bus speed.

The system motherboard is socketed for up to 4 megabytes of RAM using 1-

Proteus-286GT

Company
Proteus Technology Corp.
377 Route 17, Airport 17 Center
Hasbrouck Heights, NJ 07604
(201) 288-8629

GV-286

Company
PC Designs Inc.
2500 North Hemlock Circle
Broken Arrow, OK 74012
(918) 251-5550

MULTI USER BBS

Off-the-shelf and custom systems for:

- ★ Multi-User Teleconferencing
- ★ Multi-User Electronic Mail
- ★ Multi-User File Upload/Download
- ★ Multi-User Order Entry
- ★ Multi-User Games and Amusements
- ★ Multi-User Database Lookup
- ★ Multi-User Online Expert Systems
- ★ Multi-User Catalog Scanning
- ★ Multi-User Classified Advertising
- ★ Multi-User Educational Services

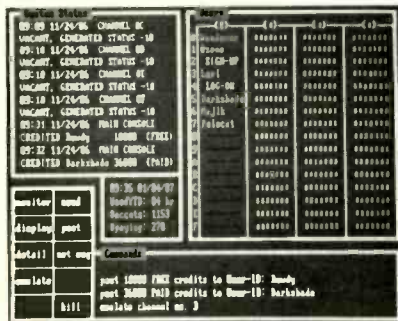

What do you need for your Multi-User Bulletin Board System?

	Us	Them
16 modems on one card	YES	?
Up to 64-user capability	YES	?
Runs under MS-DOS V3.1	YES	?
C source code available	YES	?
Menu-oriented operation	YES	?
Accounting w/audit-trail	YES	?
Extensive SYSOP displays	YES	?
Powerfail-protected data	YES	?
"Midnite cleanup" option	YES	?
1-year hardware warranty	YES	?

We sell hardware and software for the IBM PC family and compatibles. Our product line is centered around the GALACTICOMM BREAKTHROUGH, a single-slot card with 16 independent modems on it. You will simply have a cable coming out the back of your machine, going straight into the jacks in the wall installed by the telephone company. No external hardware needed.

Call our multi-user demo system with your modem, at (305) 922-3901. Then call (305) 472-9560, voice, for more information. Why not call right now?

GALACTICOMM
GALACTICOMM, Inc., 11360 Tara Drive, Plantation, FL 33325

REVIEW: MAIL-ORDER PERFORMANCE

The GV-286 is the clear winner in ease of reconfiguring the CMOS RAM.

EGA-compatible graphics board, and a serial/parallel port board, as well as the necessary documentation, all supplied by Everex. Also included with the machine is a detailed printout of the hard disk checkout data.

One of the GV-286's two serial ports terminates in a DB-25 connector mounted in a chassis cutout, and the other terminates in a DB-9 connector on the same slot cover with a single DB-25 parallel port connector. Everex's documentation about these ports is far more complete than the information that you would normally receive about them. You can configure the serial ports on this board as either data terminal equipment (DTE) or data communications equipment (DCE) by changing a jumper. A 9-pin-to-25-pin adapter cable is also included with the Everex serial/parallel port board.

Configuring CMOS RAM

Of the two machines, the GV-286 is the clear winner in ease of reconfiguring the CMOS RAM. Each time you power up the GV-286, you are given the chance to reconfigure it. The dialog box closely follows that of the IBM PC AT diagnostics, in which the default answers are your previous configuration data. The system automatically detects and configures the memory.

The Proteus-286GT comes with a program that clears parts of the CMOS memory, so you must reconfigure the CMOS RAM each time you boot up the machine. To add or delete memory data, you must disconnect the CMOS battery for about 30 minutes. The next time you boot up the computer, the memory is automatically resized and stored in CMOS RAM, and you must reconfigure everything in the CMOS memory area; there is no way to edit the information once it is in the CMOS memory.

Keyboards

I used two optional keyboards with the GV-286: a Maxi-Switch 101 and a Key Tronic KB101. Both of these enhanced keyboards have 12 function keys located in a row above the number keys and a numeric keypad to the right of the main keyboard. A separate small keypad, which contains the cursor-control keys and the function keys that are normally active

when the Num Lock is off, is located between the main keyboard and the numeric keypad. The Escape key is next to the number 1 key, 1 1/2 inches above its traditional left-hand position. Both keyboards interchange the normal positions of the Caps Lock and Control keys. The Num Lock, Scroll Lock, and Caps Lock keys on both of these keyboards all have LED indicators.

The Maxi-Switch 101 contains a switch that lets you swap the Control and Caps Lock keys. An alternate set of key caps is supplied with the keyboard, since the two keys are different sizes. This keyboard has maximum resistance in the first millimeter of key travel and then practically no resistance. The Key Tronic KB101 has a soft, linear resistance for the entire keystroke.

The Proteus-286GT I reviewed came with an 86-key IBM PC AT-style keyboard with 10 function keys and an even resistance over the full keystroke that is more crisp than that of the Key Tronic KB101 keyboard.

Operating Systems and Software Compatibility

Both of my review units were shipped with MS-DOS 3.2, GWBASIC 3.2, EGA board utilities, and hard disk utilities. The MS-DOS/GWBASIC combination is a separately priced option for both machines. The Proteus-286GT comes with several specific utilities that let you reset the date and time (although you can't do this when booting the computer), an EMS 3.2 memory simulator, and a program that moves a file from one directory to another. The GV-286 software package includes a utility for the Everex serial/parallel port board, a copy of PC-Write on the Everex I/O utilities disk, and a copy of Quarterdeck's DESQview multitasking program.

I tested the high-speed mode of both machines by running the DOS 3.xx versions of the following programs: Graph-in-the-Box 1.3, dBASE III, Story Teller, WordStar Professional 3.31, SuperCalc 3 2.1, Multiplan 1.06, and Boardroom Graphics 3.0. In addition, I tested Connect on the Proteus-286GT. All these programs worked fine.

I also tried three additional operating systems on each machine: Concurrent PC DOS 4.1 and Concurrent PC DOS XM 5.0, Microport Unix System V/286 1.3, and Digital Research's FlexOS 286 1.31, a new multiuser/multitasking, real-time, protected-mode operating system. Concurrent PC DOS 4.1 and Concurrent PC DOS XM worked fine on both machines most of the time. However, the GV-286 crashed twice while running Concurrent PC DOS 4.1 with Access Manager 1.1 as

a background task, a task running on one virtual console doing intensive disk I/O (through both Access Manager 1.1 and Concurrent PC DOS 4.1), and VEdit 1.3 running on a second virtual console while VEdit was apparently attempting disk I/O.

I say "apparently" because I may have caused the failure by entering disk I/O commands. Both failures occurred while I was using the Maxi-Switch 101 keyboard. I used three different keyboards (the Maxi-Switch 101, the Key Tronic KB101, and the Proteus-286GT's PC AT-style keyboard) on the GV-286 at various times. The two crashes occurred over a 30-hour period of mixed usage with Concurrent PC DOS 4.1 and various programs, but despite four more hours of purposely attempting to crash the system under the same circumstances, I was unable to do it.

I brought up Microport Unix System V/286 on both machines without any problems, but I couldn't extensively test the multitasking capabilities of this operating system due to a lack of suitable software. I installed 2.5 megabytes of additional memory on the Proteus-286GT and started up Digital Research's FlexOS, but it would not run. The Proteus-286GT

was able to read the boot track and load the operating system, but when it attempted to read in COMMAND.286 (the equivalent of COMMAND.COM), the system displayed an error message saying that COMMAND. couldn't be found.

The most significant incompatibility I encountered was with a 2.5-megabyte 70-millisecond RAM chip Cheetah memory board. When the GV-286's and Proteus-286GT's microprocessors were running at 12 and 12.5 MHz, respectively, neither machine could recognize and size the board correctly, even though both companies say that the buses run at 6 MHz. The Proteus-286GT couldn't find the board at all, while the GV-286 either couldn't find it or sized it incorrectly and detected errors in it. When I set both review machines up with the microprocessor and the bus at 6 MHz, however, they ran the Cheetah board flawlessly. This might be a timing problem caused by the difference between the microprocessor and bus speeds. I had no way to determine this, however.

Benchmarks

The GV-286 is from 15 percent to 23 percent faster than the Proteus-286GT on all microprocessor and memory bench-

marks; how much faster depends on the particular benchmark and the design of the two computers. The Disk Access in BASIC test results were mixed, since they don't depend on just microprocessor and memory speed.

The program and the data used for the Calculations benchmark will fit in cache memory concurrently and will therefore run with no wait states. The Sieve benchmark's data is a large array, so data has to be swapped in and out of cache memory along with the program and appropriate parts of GWBASIC. The GV-286 ran slower than a true zero-wait-state machine, but still faster than a machine without cache memory. The bottom line is that the Proteus-286GT is almost twice as fast as the 8-MHz IBM PC AT, while the GV-286 is a little more than twice as fast as the 8-MHz PC AT. The complete benchmark results are shown in the graph on page 247.

Documentation

Both machines come with a user's manual, an MS-DOS 3.2 user's guide, and a GWBASIC user's guide. In addition, the Proteus-286GT comes with the *MS-DOS Programmer's Reference*. The Proteus

continued

9 Track Tape Drives

For IBM PC/XT/AT and Compaq 386



Qualstar 1052

- 1600/3200 bpi
- 25/50 in./sec.
- Manual load
- Streaming

Subsystem price:
\$3,595.



Cipher Data F-880

- 1600/3200 bpi
- 25/100 in./sec.
- Auto load
- Start/Stop & Streaming

Subsystem price:
\$4,995.



Kennedy 9600A

- 800/1600/3200 bpi
- 50/100 in./sec.
- Auto load
- Start/Stop & Streaming

Subsystem price:
\$6,495.



Anritsu 2620

- 1600/3200/6250 bpi
- Cache buffered
- Auto load

Subsystem price:
\$9,495.

Let Overland Data match your specific application needs to one of its wide range of 9 Track Tape Subsystems for the IBM PC/XT/AT and Compaq 386. Subsystem prices include 9 track tape drive, interface board, cables, data interchange and backup software for MS-DOS or XENIX operating systems.

Interface boards are warranted for two years, parts and labor. Call for specific tape drive warranty information, and to find out about our special Demonstration Unit Program.

Let Overland Data's professional technical staff help you select the right tape drive for your personal computer system. Additional tape drive models available. Call today.



Overland Data, Inc.

5644 Kearny Mesa Road
San Diego, CA 92111
Tel. (619) 571-5555
Telex 754923 OVERLAND

IBM PC, XT, AT are Registered Trademarks of International Business Machines Corp.
XENIX and MS-DOS are Registered Trademarks of Microsoft Corp. Compaq 386 is a Registered Trademark of Compaq Computers, Inc.

Technology's version of the above manuals consists of four small softbound volumes in a single slipcase. The PC Designs' version comes in two miniature vinyl three-ring binders. The Proteus-286GT also comes with an additional *Introduction to the Proteus Environment*, which is tailored to the novice user and describes computer basics (e.g., floppy disks and graphics boards).

Both machine's user's guides include sections for the novice, with information on handling computer boards and removing and replacing the case and disk

drives. Beyond that, the Proteus-286GT user's manual has a weak technical section that is confined mostly to diagrams and annotations of items like connector pins and slot and socket locations. The manual gives little explanation of what is going on, and the diagram descriptions are weak. [Editor's note: *Proteus Technology says that it is now preparing a new user's manual.*]

The GV-286 user's manual is more complete and clearer on technical matters, such as definitions of the system interrupts and I/O address mapping, than

the Proteus-286GT manual. The material is also easier to find and understand in the GV-286 manual. In short, the GV-286 manual is adequate, but the Proteus-286GT's manual is not.

Warranty and Service

PC Designs provides a one-year repair or replacement warranty and one year of toll-free technical telephone support with the GV-286. The company also has a 30-day money-back (except for shipping charges) compatibility guarantee. All service is handled by PC Designs at its Broken Arrow, Oklahoma location.

Proteus Technology has a 30-day money-back satisfaction guarantee and a 15-month labor and parts warranty for the Proteus-286GT. During this period, service is provided by a third-party service supplier. Proteus provides the first 60 days of service at the customer's site for no additional charge. Proteus also has a technical-support number during business hours and operates a 24-hour on-line bulletin-board service for registered owners.

Assessing the Trade-Offs

Both of these machines offer substantial gains in microprocessor performance over the PC AT and many of its clones, and both exhibit good PC AT software compatibility. However, they both suffer some hardware compatibility problems when the microprocessor is running in fast mode with the bus at a PC AT-compatible speed.

PC Designs pays better attention to details, such as board layout, heat dissipation, CMOS reconfiguration, port placement, and documentation, with the GV-286 than Proteus Technology does with the Proteus-286GT. Proteus, on the other hand, offers better service if you can't afford downtime. The Proteus-286GT can also hold a full 4 megabytes of RAM on the motherboard, which may eliminate the need for an add-on board. [Editor's note: *Due to variations in price and availability of options, contact the companies for the latest configurations of these systems.*]

In either case, you should weigh the cost and performance advantages of a higher-speed hard disk drive for either of these systems. The Seagate ST4038 just isn't fast enough for the performance potential that these computers offer. Both machines are strong contenders for multi-tasking, and a faster hard disk drive can only improve this situation.

If you want a high level of performance in a moderately priced computer and you are willing to carefully check out the add-on boards, either of these machines is a good buy. ■



Fortron 80386 Beats the Systems

*Fortron provides
more of the features
you need!*



Cpu Mother Board
Assembled in U.S.A.



2 MB Memory Board
Intel iSBC 386/MEM 020 Compatible
Assembled in U.S.A.



Power Supply
Fortron FC5192
U.L. Listed
(CSA/UL Model Available)



Keyboard
MaxI-Switch 101-Key Enhanced

Compare Our Standard Features

- Intel iSBC 386 Compatible
- Standard 2 MB Memory (Expandable to 16 MB)
- 2 x 32 Bit Wide Data Bus
- Supports 80287 Math Coprocessor
- On-Board 2 serial/1 parallel port (Optional)
- Supports 80387 Math Coprocessor

Applications

Compatible with IBM PC/AT™ Ideal for CAD/CAE/CAM/CAT workstations, network file servers, multi-users UNIX/ZENIX.

Order the complete system or individual components.

Built with quality.

Corp. accounts and VARS welcome, too.



FORTRON

2380 Qume Dr. Ste. F
San Jose, CA 95131
Ph: (408) 432-1191
TX: 559291
FX: (408) 432-1303

Hours: Mon.-Fri.
7 a.m.-6 p.m. PST

Intel iSBC 386 is a registered trademark of Intel Corp

NEW AND ENHANCED IBM VGA COMPATIBLE

EGAWONDER™

Any Software. Any Monitor. Any Time.

800x560

640x480

Any Software On An RGB Monitor



Any Software On A Monochrome Monitor



Any Software On An EGA Monitor



Any Software On A Multisync Monitor

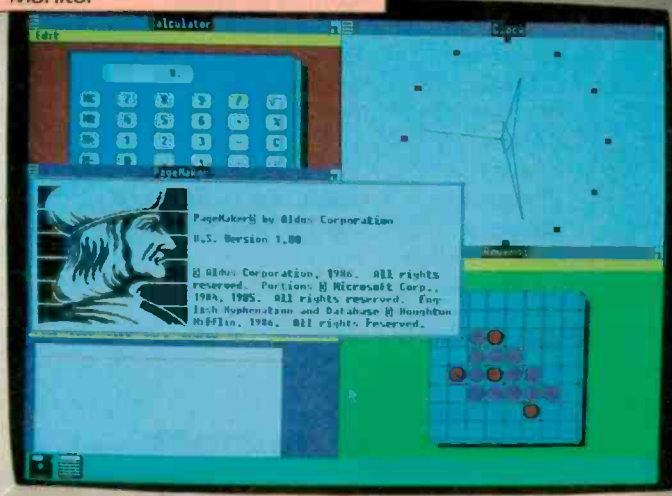

Now, EGA WONDER displays VGA on multi-sync monitors.

Without switching or having to take the system apart, without having to use specific monitors for specific programs, the EGA WONDER, with SoftSense Automatic Mode Switching, upgrades the EGA standard and maintains downward compatibility to older standards on any monitor.

EGA WONDER now runs the new IBM VGA⁵ graphics standard plus 800x560, 752x410 and 640x480 high resolution text and graphics on MultiSync type monitors and 752x410 resolution on 25kHz 400 line monitors providing a WYSIWYG display for popular desktop publishing software such as PageMaker and Ventura Publisher. With high resolution drivers to enhance Windows, AutoCAD, GEM, 1-2-3 and Symphony, EGA WONDER displays desktop publishing, computer aided design, spreadsheets and icon operating environments with up to twice the normal resolution of EGA on MultiSync monitors.

EGA WONDER's expanded 132 column capability allows Lotus users to display a year-at-a-glance of information on 1-2-3 and Symphony spreadsheets. Connectivity support to mini and mainframe computers is provided because EGA WONDER runs SmartTerm and VTerm in 132 columns. Word processing in 132 columns is fully supported on WordStar and WordPerfect.

EGA WONDER supports 800x560, 752x410 and 640x480 modes on MultiSync monitors, 752x410 on 25kHz 400 line monitors and EGA, CGA, MDA, Hercules and 132 column modes on MultiSync, EGA, 400 line 25kHz², RGB³, TTL Monochrome, Composite⁴, Compaq Portable⁵ and IBM PC Portable monitors.

EGA WONDER represents a new beginning for users of IBM PC/XT/AT, IBM Series 2 Model 30, or compatible computers and is now available from all major computer stores. Call us today at (416) 756-0711 for more information.

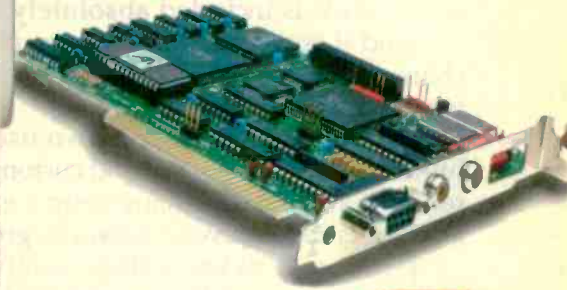

ATI Technologies Inc.
3761 Victoria Park Ave.
Scarborough, Ontario, Canada M1W 3S2
Tel: (416) 756-0711 Fax: (416) 756-0720
Tlx: 06-966640 (ATI TOR)

Technology you can Trust.

Trademarks: ATI, EGA WONDER - ATI Technologies Inc., IBM - International Business Machines Inc., Compaq - Compaq Computer Corp., MultiSync - NEC Home Electronics Inc., Windows - Microsoft Inc., GEM - Digital Research Inc., 1-2-3 - Symphony - Lotus Development Corp., Ventura Publisher - Xerox Corp., PageMaker - Aldus Corp., SmartTerm - Perisoft Inc., VTerm - Coefficient Systems Corp., AutoCAD - Autodesk Inc., Hercules - Hercules Computer Technology Inc.
(1) Any Software, Any Monitor: Any Time applies to IBM digital monitors, graphics, standards.
(2) 132 columns not available on 25 kHz monitor.
(3) EGA, MDA, Hercules software displayed via interlacing on RGB and Composite monitors. Flickering effect of interlacing reduced with anti-glare screen filter. All other modes are non-interlaced.
(4) Via optional Compaq Expansion Module - Suggested list price - \$99.
(5) Runs VGA Modes 11 & 12 on MultiSync Monitors.

Get a new handle on your business with SBT.



**Now Available
for SCO XENIX**

Now you can handle up to 254 users, all working in the same data files, with the SBT MultiNet Database Accounting Library. The accounting software written in dBASE III PLUS.

So whether your business is large or small, you can grow to the limits of the most advanced PC networks available.

When you want that special report, or your business needs something we didn't think of, you can quickly and easily modify our programs to meet your needs exactly (because our dBASE source code is included **absolutely free**).

And if you don't have time to make the changes yourself, there's a nearby consultant who can make them for you.

So if your company has two users or two hundred and fifty, you can add customers, update records, and have as many people enter orders as it takes to keep your business growing.

Isn't it nice to know there's software you can't outgrow? The SBT MultiNet Database Accounting Library.

Now you can get a new handle on your business.

Call today for our demo disk and brochure.

THE SBT DATABASE ACCOUNTING LIBRARY.

dProfessional	Time & Billing	\$395
dOrders	Sales Order Processing	\$295
dInvoice	Billing/Inventory Control	\$295
dStatements	Accounts Receivable	\$100
dPurchase	Purchase Order	\$295
dPayables	Accounts Payable	\$395
dPayroll	Payroll/Labor	\$395
dLedger	General Ledger/Finance	\$395
dAssets	Asset/Depreciation	\$295
dProject	Project/Job Accounting	\$395
dProperty	Tenant/Unit Management	\$395
dMaterials	Manufacturing Planning	\$395
dMenu/Backup	Menu/Backup	\$ 65

MultiNet versions \$200 additional per module

Call today for the name of the SBT consultant in your area.

One Harbor Drive
Sausalito, CA 94965 (415) 331-9900
Telex 9102404708

Macintosh, Atari and compiled versions are available. dBASE III PLUS is a registered trademark of Ashton-Tate, Inc. Macintosh is a trademark of Apple Computer, Inc. Atari is a registered trademark of Atari Corp. XENIX is a registered trademark of Microsoft Corp. SCO is an abbreviation of the Santa Cruz Operation. SBT Database Accounting Library and MultiNet are trademarks of SBT Corp. © 1987, SBT Corporation.



The NEC MultiSpeed

David Satz

*Portability, speed,
user-friendliness, a low price, but
with some flaws*

The NEC MultiSpeed tries to hold true to the adage that good things come in small packages. The MultiSpeed is a portable, battery-operated MS-DOS computer with 640K bytes of RAM and a supertwist LCD screen. It runs at both 4.77 and 9.54 MHz and comes with ROM-resident utility software and on-line help files. In addition to having two internal 720K-byte 3½-inch floppy disk drives, the MultiSpeed is capable of maintaining files in an internal, nonvolatile RAM disk. Its suggested retail price of \$2195 includes MS-DOS 3.20, the ROM-resident utilities, a set of four spiral-bound manuals, and an AC adapter. [Editor's note: NEC has introduced the MultiSpeed EL (\$2495). It has the same features as the original MultiSpeed plus an electroluminescent backlit LCD screen and a larger power supply.]



The Inner Sanctum

The MultiSpeed is built around NEC's V30 microprocessor, a CMOS chip that is compatible with Intel's 8086 but with a different internal architecture, giving faster performance even at the nominal 4.77-MHz clock rate. Normally, though, the computer boots up and runs at 9.54 MHz. You can select the slower speed by invoking a ROM-resident setup routine or by setting a rear-panel configuration switch. NEC claims that the MultiSpeed's microprocessor runs with zero wait states at either speed, except when the LCD screen is being updated. There are two empty ROM sockets in the underside of the computer, but no socket for a numeric coprocessor.

This 11-pound computer is not the most petite of laptop designs, but you can carry it comfortably by the slide-out aluminum handle. Its extra few cubic inches

provide keyboard features that will be reassuringly familiar to desktop computer users: a separate numeric/cursor-control keypad on the right-hand side (set above the main keyboard) and 10 function keys arranged in two columns along the left. The 85 full-size, full-stroke keys are cleanly designed with a moderately stiff spring action and very little play or wiggle; they touch bottom with a smart tap. The nonslip-textured key tops are comfortably contoured, with the *F* and *J* keys scooped out more deeply than the others. The layout of the main keyboard closely resembles that of the original IBM PC's keyboard, except for the addition of special Pop Up and Help keys. LED indicators are built into the Caps Lock and Num Lock keys.

The MultiSpeed is ready to run as soon as you check the four rear-panel config-

uration switches, install the main battery, connect its polarized three-pin cable connector, and switch the backup battery into operation. After turning on the main power switch and angling the screen into position, you can abort the power-on self-test RAM-check routine by pressing the space bar. A slider control to the right of the LCD screen adjusts the screen's contrast.

The reflective (nonbacklit) supertwist LCD screen has a 1.6-to-1 aspect ratio and good overall legibility. The screen can display 80 characters by 25 lines and either 320 by 200 or 640 by 200 pixels. Programs that require an IBM Color Graphics Adapter (CGA) can be indirectly displayed with differential shading of the LCD. The main character font is attractively designed with a single-dot line thickness in an 8 by 8 matrix. The pixels look like thin upright purple rectangles set against a vaguely greenish

metallic background. The contrast is distinctly greater than that of other LCD screen types. The screen is mounted in the lid of the unit, and you can remove it to facilitate the use of a CRT monitor if desired. No audible alarm or shut-off switch is provided to prevent the lid from closing when the battery power is still on.

The NEC MultiSpeed features a battery-backed RAM disk; its contents survive rebooting DOS, even after a crash due to main battery failure. You can set the RAM disk for any size up to 126K bytes. Usually, 2K bytes of battery-backed RAM is reserved for system setup parameters, so that even with no RAM

continued

David Satz (118 State St., Apt. C, Brooklyn Heights, NY 11201) is a classical musician and recording engineer.

disk allocated, the maximum memory space available for DOS and applications software is actually 638K bytes. (The KILL64R.COM program, which is available on the system disk or from NEC, will free up the remaining 2K bytes of RAM.)

Mass-storage facilities consist of two 3½-inch floppy disk drives that use the same 720K-byte double-sided, double-density format as that of the IBM, Toshiba, Zenith, Data General, Kaypro, Datavue, and Bondwell laptops. The disk drive openings, located along the right-hand side of the computer, are protected by spring-loaded door flaps. When you insert a disk, its window shutter is slid aside immediately to save a few moments during initial access. A front-panel LED shows when the drives are operating, although the drives are loud enough to remove any doubt.

You can set up the floppy disk controller (FDC) to draw its operating current either continuously or only during a disk operation. The *User's Guide* warns of a slight slowdown of initial disk access when this FDC Power Save mode is on, but I found it had no observable effect on disk performance either in the benchmark tests or during ordinary use.

The back panel has DB-25 connectors for the parallel and RS-232C serial ports and a DB-9 for the RGB color monitor. Also on the back panel are a tiny blue hardware reset button, a coaxial socket for an AC adapter or an optional automobile 12-volt adapter cord, four DIP configuration switches, and a backup power switch that controls an internal nickel-cadmium battery, which preserves the setup parameters and the RAM disk contents when the main battery is discharged or being exchanged. The MultiSpeed also has a 15-pin socket, labeled EXT FDC, that you can connect via an optional cable to the FDC port of an IBM PC or PC XT to allow the disks in the MultiSpeed's internal drives to be directly accessed by the other computer. This is partial compensation for the lack of any means of connecting external disk drives or expansion units. No access to the system bus is available from outside the computer.

The MultiSpeed's nickel-cadmium battery can run the computer for up to 4 to 6 hours following an 8-hour charge. The battery life varies with floppy disk usage. When the battery voltage begins to trail off, a red LED above the main keyboard blinks during disk operations and then glows steadily. After a few minutes, a beep is sounded, and this warning appears on the screen: Power failure has occurred. Save all data files immediately. Press any key to resume session. Saving data to a floppy disk re-

quires a lot of power, which often brings this message up repeatedly (e.g., between individual disk operations when you try to comply with its demands). On my first cycle, I was granted 45 minutes of continued use after the audible warning, but the next time around it was only 15 minutes before it crashed. You can use the nonvolatile RAM disk for saving files on short notice, but you must enable it beforehand because you can't set one up without rebooting; there wouldn't normally be enough juice left anyway.

The MultiSpeed's main battery is easily accessible from the top of the computer through an access cover. Owners might want to carry a spare; replacement batteries cost \$99. You can operate the computer while the battery is recharging, but the *User's Guide* warns that external power should not be connected while the computer is switched on. Therefore, to continue operating, you would have to save your data, power down, change to external power or a spare battery, and reboot. The battery-charging current automatically decreases after about seven hours of recharging. However, if a battery that still has some power left is connected to the computer's external power, it can become rather warm, whether the computer is running or not. According to NEC, too much overcharging can decrease the life of the battery.

Hits and Misses

The MultiSpeed can be fitted with an optional 300/1200-bps auto-dial/auto-answer internal modem, which operates to U.S. standards only. It responds to the Hayes-type AT command set and should be compatible with most communications software or with the built-in TELCOM program.

For instructions on overall operation, the *User's Guide* is helpful and clearly written. A brief (76-page) *Introduction to MS-DOS* explains the most rudimentary DOS commands for beginners. The two other volumes included with the MultiSpeed describe the operation of the ROM-resident programs. Nowhere is there any mention of the more advanced DOS utilities—not even an overview of their functions or a summary of their command syntax.

The overall construction of the computer is good, except for the faulty design of the screen-lid hinge mechanism. For it to work, you must set the lid into position in exactly a certain way. You must lift up the lid, set the angle, and press a button on the right side; it must never be re-adjusted backward unless you first release the hinge lock by pulling the lid forward, or you can damage the hinge. NEC has elected to exclude any such damage

from its warranty coverage.

The MultiSpeed has a one-year parts and labor warranty period, with an optional extended-service contract. According to NEC, MultiSpeed owners who need repairs can call a toll-free number, identify themselves, and give a credit card number, whereupon NEC will ship out a replacement computer and a return authorization. Owners then send the defective units to NEC.

Compatibility

The MultiSpeed's major obstacle to software compatibility is its inability to interface with external disk drives and use copy-protected software on 5¼-inch floppy disks. The availability of software on 3½-inch floppy disks has improved with the introduction of the IBM Personal System/2 computers. However, limiting a computer exclusively to 3½-inch disks is somewhat premature. The only hardware solution, slaving the MultiSpeed to an IBM PC or PC XT, does not overcome the copy-protection problem, and some users do not have access to suitable desktop computers at their convenience.

The machine's special features bring about another potential source of trouble. The interrupts that trigger the ROM-resident programs and on-line help (interrupts 80, 81, and 82), although officially reserved for BASIC, are occasionally used by applications programs. Such programs can run on the MultiSpeed only if the ROM-resident programs are disabled, which the SETUP program allows you to do by reclaiming their workspace in RAM. However, SETUP cannot disable itself. For drastic instances, you can disconnect the special keys entirely from their interrupts with the KILLPOP.COM program, available on disk with the system, from NEC dealers, or by downloading it from the NEC bulletin board. [Editor's note: You can obtain this program by calling 1-800-NEC-SOFT for information or 1-800-NEC-RBBS to access the NEC bulletin board.]

NEC claims that software that produces a conflict is rare. Despite my earnest attempts to make trouble, all my MS-DOS software ran well on the MultiSpeed, including Flight Simulator 2.13, Turbo Pascal 3.01A, SideKick 1.56A, MEX-PC 1.65A, Microsoft Word 3.1, and QuickBASIC 2.01 (once they were transferred to 3½-inch disks).

Resident Programs

The MultiSpeed's ROM-resident programs include SETUP, for the selection of system parameters, including RAM disk size, microprocessor clock speed, CGA emulation parameters, and the FDC Power Save mode; OUTLINER, for out-

NEC MultiSpeed

Company

NEC Home Electronics (U.S.A.) Inc.
Computer Products Division
1255 Michael Dr.
Wood Dale, IL 60191-1094
(312) 860-9500

Size

13½ by 12 by 3 inches; screen size: 9 by 4¾ inches; weight: 11 pounds

Components

Processor: Intel 8086-compatible
NEC V30, switchable between 4.77 and 9.54 MHz

Memory: 640K bytes of 150-ns CMOS and dynamic RAM (up to 126K bytes can be allocated to the nonvolatile RAM disk); 512K bytes of ROM; internal sockets for additional ROM

Mass storage: Two 720K-byte double-sided, double-density 3½-inch floppy disk drives

Display: 80-column by 25-row supertwist LCD; emulates IBM CGA to give 320 by 200 or 640 by 200 monochrome graphics

Keyboard: 85 keys; 10 function keys; separate numeric/cursor-control keypad
I/O interfaces: RS-232C serial port, male DB-25 connector; Centronics parallel printer port, female DB-25 connector; external floppy disk controller interface port, female DB-15 connector; IBM PC-compatible RGB video port; coaxial socket for DC operation and battery-charging current

Software

MS-DOS 3.20; Phoenix ROM BIOS; TELCOM, NOTEPAD, FILER, OUTLINER, DIALER, and SETUP programs; on-line help files

Options

300/1200-bps internal modem: \$399
External Transfer Kit (includes cable and software for slaving the MultiSpeed's internal disk drives to an IBM PC or PC XT FDC port): \$99
12-volt automobile power adapter cord: \$20
Carrying case: \$99

Documentation

User's Guide, 186 pages;
Introduction to MS-DOS, 76 pages;
TELCOM/DIALER User's Manual, 136 pages; OUTLINER/FILER/NOTEPAD User's Manual, 284 pages

Price

\$2195

DISK ACCESS IN BASIC (IN SECONDS)

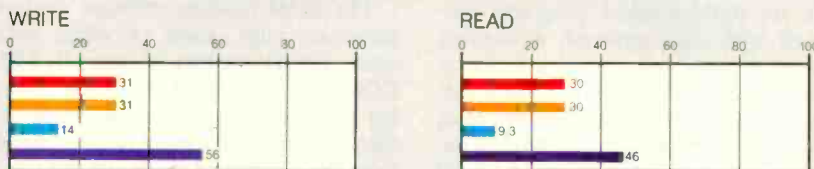

BASIC PERFORMANCE (IN SECONDS)

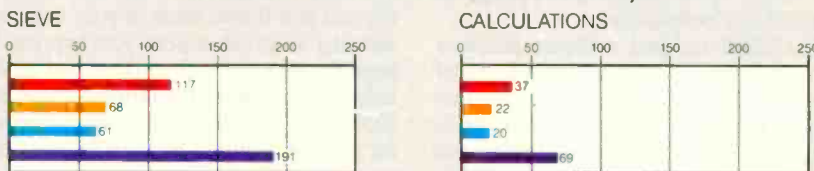

SYSTEM UTILITIES (IN SECONDS)

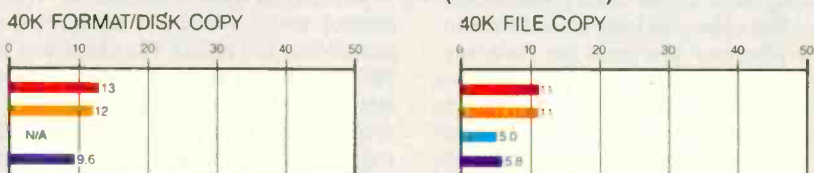

SPREADSHEET (IN SECONDS)



■ NEC MULTISPEED (4.77 MHz) ■ NEC MULTISPEED (9.54 MHz)
■ IBM PC AT (8 MHz) ■ IBM PC

The graphs for Disk Access in BASIC show how long it takes to write and then read a 64K-byte sequential text file to a blank floppy disk. (For the program listings, see *BYTE's Inside the IBM PCs*, Fall 1985, page 195.) The Sieve graph shows how long it takes to run one iteration of the Sieve of Eratosthenes prime-number benchmark. The Calculations graph shows how long it takes to do 10,000 multiplication and 10,000 division operations using single-precision numbers. The System Utilities graphs show how long it takes to format and copy a 40K-byte file using the system utilities. The 40K Format/Disk Copy test was not performed on the PC AT because the computer had only one floppy disk drive. The Spreadsheet graphs show how long it takes to load and recalculate a 25- by 25-cell spreadsheet in which each cell equals 1.001 times the cell to its left. The spreadsheet used was Microsoft Multiplan. Tests on the NEC MultiSpeed were done using MS-DOS 3.2, GWBASIC 3.2, and Multiplan 1.06. Because the MultiSpeed's software package does not include any programming language, all BASIC tests were run with a generic version of GWBASIC.

line processing; NOTEPAD, for basic word processing; FILER, for message filing; DIALER, for operation of the internal modem's dialing facility; and TELCOM, for telecommunications. You

call an overall menu onto the screen by pressing the Pop Up key for about 1 second, or you can invoke a particular routine by pressing the Pop Up key plus the first letter of the program's name. You

can also call ROM-resident programs by name from the DOS command line, and they can interrupt most applications and each other freely. NEC has designed a

continued

certain measure of data protection into the MultiSpeed: If you shut off the power switch or press Control-Alt-Delete while there are ROM-resident programs suspended with data unsaved, a warning message appears and gives you a chance to save the data. All unsaved data is lost when you reboot with the hardware reset switch. Also, changing the RAM disk parameters forces a cold start and the loss of all the RAM disk's previous contents; the exit menu from the SETUP program warns of this eventuality.

The ROM-resident software attempts to be self-documenting by means of menus and a context-sensitive on-line help facility. In a manner that is strikingly similar to Microsoft Multiplan and Word, the prompt/menu lines are always on-screen during program execution. Backing these up are more detailed messages that appear in large on-screen windows whenever you press the Help key. The messages are available whenever ROM-resident programs are run, even to remote users when TELCOM is operating the auto-answer modem. The message texts could stand to be proofread (e.g., Newline: Toggles whether or not a linefeed with follow each carriage return.). But they are thorough; if they don't tell you how to do something, you probably can't do it.

Impressions

The MultiSpeed was pleasant to operate as soon as I learned where to reach for the cursor-control keys. I also found the Shift and Enter keys too small and narrow for my taste. The LED indicator on the Num Lock key toggles when the key is pressed, regardless of the actual status-bit setting; when I ran SideKick, its calculator, which manipulates the status bit directly, was able to throw the indicator into the reverse of its proper function.

The supertwist LCD screen is easy to read under strong overhead lighting; I observed no ripple under 60-hertz fluorescent lighting. However, the single-dot thickness of the normal font characters makes reverse video very difficult to read. The slowness of the screen display, a characteristic of supertwist LCDs, is also bothersome at times. Still-standing screen messages waft gently into place; I found scrolling text difficult to read. I could not scan bulletin-board messages using an external 2400-bps modem, nor could I read screen listings using the DOS TYPE and DIR commands. Rapid typing is also a bit disorienting—I suffered "cursor anxiety" when deleting text with repeated backspaces. I did, however, like the screen's effect on animated displays and game programs. For example, it imparts an eerie, slithering motion to the

cells in Conway's Game of Life, and the screen objects in Flight Simulator seemed to rhythmically undulate.

The ROM-resident software contains numerous bugs, some of which could cause significant loss of data. In TELCOM, for example, if you begin capturing text within the Terminal mode and then suspend it, you must rename the file from the Command mode, or the file is never closed. If it is not renamed, you'll have a zero-length file in the disk directory, and you'll lose most of your data; no warning is given unless you happen to page through the various Terminal mode help screens. When operating without the XON/XOFF protocol, the pause needed for writing captured text to a floppy disk or to view the previous screen causes a loss of any incoming data.

NOTEPAD gets confused by ASCII control codes, which it interpreted as end-of-line and end-of-file characters the first time I tried to use it with preexisting text. When I gave the program a chance to originate a text file more to its own liking, I typed for a while and, long before the end of the available buffer space, it suddenly decided not to allow characters to be inserted. It signaled INTERNAL ERROR (which the on-line help explained as Severe internal error was detected) and asked whether I wanted to recover this file. I typed a Y and was greeted with the message: Document in memory cannot be recovered. Press any key to resume. The text file itself, which I had saved to disk a moment before the error message appeared, showed no irregularities, and I could edit it under SideKick. This error message came up each time I reloaded the file and attempted to insert a character. (When I contacted NEC about the problem, the company responded by saying that NOTEPAD was designed for general-purpose word processing with ASCII text files, and that files created with other word-processing programs that contain control codes embedded in text may not be compatible with it.)

Other details of NOTEPAD and TELCOM are poorly thought out. NOTEPAD starts in the Edit mode with an empty screen while displaying the Command mode menu, looking like it needs a command letter; the command letter goes, of course, into the text window, and you must delete it before hitting Escape to get to the actual Command mode. In Command mode, however, there is no prompt for getting back to the Edit mode; you have to ask for help to find out that you have to press Escape once again.

Benchmark Performance

The benchmark results for the NEC MultiSpeed show a level of microproces-

sor performance that puts it in the speed category of a slow PC AT-class machine; this is quite commendable for a computer with a list price of just over \$2000. By comparison, the similarly priced Zenith Z-181 takes over 205 seconds to run the Sieve test, while the MultiSpeed runs it in just under 140 seconds. The Core International Disk Performance Program gives average access times for the MultiSpeed in the neighborhood of 200 milliseconds, just slightly better than those obtained with the Toshiba T1100 Plus and the IBM PC Convertible. I obtained the MultiSpeed's benchmark times for the Disk Access in BASIC tests with the FDC Power Save mode off. This had no measurable effect on the benchmarks, since, in these tests, the disk drives run continuously. The complete benchmark results appear on page 255.

Final Impressions

The MultiSpeed is relatively inexpensive, highly portable, has a fast microprocessor, and is user-friendly. The keyboard is of good quality; for some users, the existence of a separate numeric keypad will justify the awkward position of the cursor-control keys. The nonvolatile RAM disk facility is a natural feature for a battery-operated computer.

The supertwist screen is nicer to look at than to use. Its qualitative advantage over the best conventional LCD screens should not be overstated; it is still critically dependent on ambient lighting (especially in reverse video), and, while its contrast ratio is higher than that of many other units, it is still a contrast between two dark colors. Furthermore, the supertwist pixels are a little slow, which can be irritating.

The lack of an external 5 1/4-inch floppy disk drive (or any hardware expansion at all) is a severe limitation. I'm sure most users would rather have the FDC socket rewired for this purpose. However, serial-port transfer programs, such as Brooklyn Bridge and LapLink, are available for file transfer via the RS-232C port.

The MultiSpeed's ROM-resident programs offer more than minimal functionality, but they also contain more than minimal bugs. The computer's software compatibility is infringed upon by these features, and some users may choose to disable them.

Despite its weak points, the MultiSpeed is a fast and easy-to-use computer. If you disregard the bugs in the ROM-resident software, the extra features and fast microprocessor could make this computer a favorite with first-time users, as well as experienced users who need portability and speed. ■

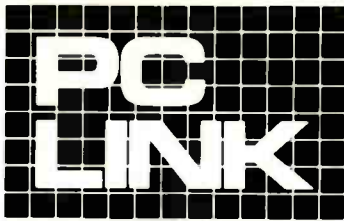

INDEPENDENT STORE IN NYC DEDICATED TO IBM PC SOFTWARE AND PERIPHERALS ONLY

If We Don't Have It, It's Probably Not Worth Having.

STORE HOURS: 9:00 A.M.-5:30 P.M. E.S.T. MON.-FRI.

SATURDAYS: 10:00 A.M.-4:00 P.M.

Terms, Conditions and Prices May Differ In Our Store.

CORPORATE ACCOUNTS WELCOMED.

PC LINK, CORP. 29 WEST 38TH STREET. 2ND FL., NEW YORK, NY 10018

CALL TOLL FREE 1-800-221-0343 All prices listed in this ad are effective September 1-31, 1987. All Brands are Registered Trademarks. IBM is a Registered Trademark of IBM Corp. IN NEW YORK CALL 1-212-730-8036

THIS MONTH'S SPECIALS—SEPTEMBER 1ST through SEPTEMBER 30TH.

JAVELIN SOFTWARE	GREAT PLAINS SOFTWARE	SEAGATE	XYQUEST
JAVELIN 89.00	EACH PACKAGE..... 499.00	ST225 (20MB)+WDC... 319.00	XY WRITE 111 279.00
BUSINESS SOFTWARE	IMSI DR. HALO 11 39.00	SEAGATE ST-238 30MB + ADAPTEK 479.00	SEAGATE ST-238 30MB + ADAPTEK 479.00
ADVANCE LOGIC	IMSI DR. HALO 11 (D.P.E.) 89.00	SEAGATE 20MB ST-4026 FOR AT 559.00	SEAGATE 20MB ST-4026 FOR AT 559.00
AL5 18C FINANCIAL CONSULTANT 75.00	LOTUS DEV. FREE LANCE + (SOLD IN STORE) CALL	SEAGATE 30MB ST-4038 FOR AT 695.00	SEAGATE 30MB ST-4038 FOR AT 695.00
ANSA PARADOX 359.00	MICROGRAFX WINDOWS DRAW 129.00	SYSGEM QIC FILE 60 EXT. BACKUP 1159.00	SYSGEM QIC FILE 60 EXT. BACKUP 1159.00
ASHTON-TATE	SOFTWARE PUBLISHING	SYSGEM SMARTIMAGE 60 EXT. BACKUP 895.00	SYSGEM SMARTIMAGE 60 EXT. BACKUP 895.00
DBASE 111 PLUS 1.1 CALL	PRESENTATION GRAPHICS 279.00	SYSGEM SMARTIMAGE 20 EXT. BACKUP 695.00	SYSGEM SMARTIMAGE 20 EXT. BACKUP 695.00
MULTIMATE ADVANTAGE 11 CALL	CLICK ART 129.00	TOSHIBA ND-04D 1/2 HT. 360KB 149.00	TOSHIBA ND-04D 1/2 HT. 360KB 149.00
BORLAND INT.	XEROX VENTURA DESKTOP PUBLISHER CALL	TOSHIBA ND-04DE-G 360KB FOR AT 159.00	TOSHIBA ND-04DE-G 360KB FOR AT 159.00
EUREKA 69.00	Z SOFT. PC PAINTBRUSH + 129.00	TOSHIBA ND-08DE-G 1.2MB FOR AT 199.00	TOSHIBA ND-08DE-G 1.2MB FOR AT 199.00
PROLOG 1.1 65.00	Z SOFT. PUBLISHER PAINTBRUSH 179.00		
REFLEX V1.1 79.00			
SIDEKICK UNPROTECTED 1.5 49.00	UTILITIES	EXPANSION BOARDS	64K 150NS RAM CHIPS CALL
SUPERKEY NON PROTECTED 69.00	COMPUSERVE STARTER KIT 25.00	256K 150NS RAM CHIPS CALL	256K 150NS RAM CHIPS CALL
TURBO BASIC 69.00	CORE INT. CORE FAST 119.00	AST SIXPAK PREMIUM 256 C/S/P 209.00	AST SIXPAK PREMIUM 256 C/S/P 209.00
TURBO C 69.00	EXECUSYSTEMS XTREE 39.00	AST MINI I/O 11 BOARD C/S/P 169.00	AST MINI I/O 11 BOARD C/S/P 169.00
TURBO LIGHTNING 55.00	5TH GENERATION FAST BACK 89.00	DCA IR-MA BOARD 699.00	DCA IR-MA BOARD 699.00
TURBO PASCAL WITH 8087 & BCD 75.00	FUNK SOFT. SIDEWAYS 3.1 49.00	HERCULES MONO GRAPHICS PLUS 209.00	HERCULES MONO GRAPHICS PLUS 209.00
BYTEL GENIEFOR FOR DBASE 111 + 229.00	MICROSOFT LEARNING DOS 39.00	INTEL ABOVE BOARD PS/286 512K 439.00	INTEL ABOVE BOARD PS/286 512K 439.00
CHIPSOFT TURBO TAX PERSONAL 55.00	NORTON UTILITIES V 4.0 59.00	INTEL ABOVE BOARD PS 64K/PC 319.00	INTEL ABOVE BOARD PS 64K/PC 319.00
CENSURENTIC DATA	NORTON UTILITIES ADVANCED 4.0 99.00	TALL TREE JRAM 3 0K (TO 2MB) 209.00	TALL TREE JRAM 3 0K (TO 2MB) 209.00
R & R REPORT WRITERFOR DBASE 111 + 129.00	NORTON COMMANDER 49.00	TALL TREE JRAM-AT3 0K (TO 2MB) 229.00	TALL TREE JRAM-AT3 0K (TO 2MB) 229.00
CROSSTALK COMMUNICATIONS	PERSONICS SMART NOTES 69.00	VIDEO 7 VEGA DELUX 359.00	VIDEO 7 VEGA DELUX 359.00
CROSSTALK MK 4 149.00	REVOLUTION CRUISE CONTROL 29.00		
CROSSTALK XV1 3.6 99.00	SIM/SCH TYPING TUTOR 111 39.00	MODEMS	HAYES SMARTMODEM 2400 499.00
REMOTE 1.3 99.00	SOFTCO PROTEC 185.00	HAYES SMARTMODEM 1200 299.00	HAYES SMARTMODEM 1200 299.00
TRANSPORTER + CROSSTALK 149.00	SOFT CRAFT FANCY WORD 109.00	HAYES 1200B + SMARTCOM 11 299.00	HAYES 1200B + SMARTCOM 11 299.00
FOX SOFTWARE	SOFT CRAFT FANCY WORD 149.00	HAYES 2400B + SMARTCOM 11 499.00	HAYES 2400B + SMARTCOM 11 499.00
FOX BASE PLUS V 2.0. 249.00	SOFT CRAFT FANCY FONT 149.00	MIGENT 1200 POCKET MODEM 149.00	MIGENT 1200 POCKET MODEM 149.00
FOX BASE + MULTIUSER 399.00	SOFTLOGIC CUBIT/DOUBLE DOS ea. 39.00		
GREAT PLAINS ACCOUNTING PACKAGES CALL	SOFTLOGIC DISK OPTIMIZER 39.00	DISKETTES	DYSAN HIGH DENSITY FOR PC/AT 55.00
HAYES SMARTCOMM 11 95.00	SOFTLOGIC SOFTWARE CAROUSEL 39.00	DYSAN DS/DD DISKETTES 29.00	DYSAN DS/DD DISKETTES 29.00
JANUS ASSOC.	TRANSEC UNLOCK A + B + ea. 45.00	3 M HIGH DENSITY FOR PC/AT 39.00	3 M HIGH DENSITY FOR PC/AT 39.00
LASER PRINT PLUS 3.02 279.00	WHITE CRANE BROOKLYN BRIDGE 99.00	3 M 3 1/2" DS/DS 135 TPI 29.00	3 M 3 1/2" DS/DS 135 TPI 29.00
LASER PRINT EXTRA 39.00	GRAPHIC TABLETS,KEYBOARDS,MICE	XIDEX DS/DD DISKETTES 12.00	XIDEX DS/DD DISKETTES 12.00
JAVELIN SOFT. JAVELIN 89.00	DATA DESK TURBO KEYBOARD 139.00		
LIFETREE SOFT. VOLKSWRITER 3 149.00	KEYTRONICS KB 5151 KEYBOARD 169.00	ACCESSORIES	CURTIS SYSTEM STAND 21.00
LOTUS DEV. CORP	LOGITECH C7 MOUSE + PC PAINTBRUSH 109.00	CURTIS MONO CABLE 35.00	CURTIS MONO CABLE 35.00
LOTUS 1-2-3(SOLD IN STORE) CALL	LOGITECH C7 MOUSE + PAINT + CAD 159.00	CURTIS COLOR EXTENSION CABLE 39.00	CURTIS COLOR EXTENSION CABLE 39.00
LOTUS HAL (SOLD IN STORE) CALL	LOGITECH C7 MOUSE + CAD 129.00	CURTIS KEYBOARD CABLE 30.00	CURTIS KEYBOARD CABLE 30.00
MANUSCRIPT(SOLD IN STORE) CALL	MICROSOFT SERIAL or PS/2 MOUSE ea. 135.00	CURTIS DISPLAY PEDESTAL 30.00	CURTIS DISPLAY PEDESTAL 30.00
SYMPHONY (SOLD IN STORE) CALL	MICROSOFT BUS MOUSE 130.00	CURTIS RUBY SURGE PROTECTOR 65.00	CURTIS RUBY SURGE PROTECTOR 65.00
MECA MANAGING YOUR MONEY 3.0 129.00	SUMMA 12X12 TABLET + PAINTBRUSH 389.00	DYSAN ANTI-GLARE SCREEN 35.00	DYSAN ANTI-GLARE SCREEN 35.00
MICRO PRO	PRINTERS	KALMAR TEAKWOOD 50 DISK FILER 29.00	KALMAR TEAKWOOD 50 DISK FILER 29.00
WORDSTAR 2000 + REL2 279.00	BROTHER TWINRITER 5 CALL	KALMAR TEAKWOOD 100 DISK FILER 45.00	KALMAR TEAKWOOD 100 DISK FILER 45.00
WORDSTAR PROFESSIONAL REL 4 279.00	BROTHER M-1709 240 CPS PAR/SER CALL	KENSINGTON MASTER PIECE 99.00	KENSINGTON MASTER PIECE 99.00
MICROMIM R BASE SYSTEM FIVE 379.00	BROTHER HR-20 20CPS DAISY 359.00	MICROCOMPUTER KEYBOARD DRAWER 75.00	MICROCOMPUTER KEYBOARD DRAWER 75.00
MICROSOFT	BROTHER HR40 DAISY 589.00	MICROCOMPUTER PC TOOL KIT 25.00	MICROCOMPUTER PC TOOL KIT 25.00
EXCEL CALL	EPSON FX-86/FX-286E CALL	PC COOLING TURBO COOL FOR PC/XT 65.00	PC COOLING TURBO COOL FOR PC/XT 65.00
PROJECT 329.00	HEWLET-PACKARD LASERJET 11 CALL	SMA PC DOCUMENT TEMPLATS 12.00	SMA PC DOCUMENT TEMPLATS 12.00
QUICK BASIC 69.00	OKIDATA 192 PLUS 399.00	TRI MAG 135 WATTS POWER PC/XT 99.00	TRI MAG 135 WATTS POWER PC/XT 99.00
WINDOWS 69.00	OKIDATA 193 PLUS 559.00	TRI MAG 150 WATTS POWER PC/XT 119.00	TRI MAG 150 WATTS POWER PC/XT 119.00
CHART 195.00	OKIDATA 292 519.00	TRIPP LITE BC450 450W UPS 499.00	TRIPP LITE BC450 450W UPS 499.00
COMPLERS CALL	OKIDATA 293 699.00	TRIPP LITE BC1000 1000W UPS 1079.00	TRIPP LITE BC1000 1000W UPS 1079.00
WORD VERSION 3.1 239.00	OUTPUT TECH OT-850XL 850 CPS CALL		
MIGENT	TOSHIBA P351 MODEL 11 995.00	NETWORKING	SERVER TECHNOLOGY
ABILITY 65.00	TOSHIBA P351C (COLOR) MODEL 11 1095.00	EASLAN STARTER KIT FOR 2 PC'S 199.00	EASLAN STARTER KIT FOR 2 PC'S 199.00
ENRICH 129.00	TOSHIBA P321SL 599.00	EASLAN EXPANSION KIT FOR 1 PC'S 99.00	EASLAN EXPANSION KIT FOR 1 PC'S 99.00
MONOGRAM DOLLARS & SENSE 119.00	PARALLEL PRINTER CABLE 15.00	SCANNERS	DEST PC SCAN PLUS CALL
NANTUCKET CLIPPER 379.00	HP LASER ACCESSORIES	HEWLETT PACKARD SCAN JET CALL	HEWLETT PACKARD SCAN JET CALL
SBT ACCOUNTING SOFTWARE CALL	HEWLET-PACKARD	COMPUTERS	PREMIUM 286 10MHZ, 0 WAIT STATE CALL
SSC SOFTWARE BRIDGE 139.00	FONT CARTRIDGES	AST	TOSHIBA
STSC	(A,C,D,E,G,H,I) EA 135.00	PREMIUM 286 10MHZ, 0 WAIT STATE CALL	T1100 PLUS 640KB ONE 3 1/2" D/D CALL
APL*PLUS 499.00	(B,F,J,K,L,M,N,P,Q,T,U,V,W,X,Y) EA 225.00	TOSHIBA	T3100 640KB ONE 3 1/2", 10MB HD CALL
POCKET APL 80.00	(R,Z) EA 300.00	T1100 PLUS 640KB ONE 3 1/2" D/D CALL	
STATGRAPHICS 649.00	SOFT FONTS EA 180.00	WYSE	
SOFTWARE GROUP ENABLE V 2.0 379.00	MEMORY BOARDS FOR LASERJET 11 ONLY	PC 286 1.2MB D/D 640KB 6/8 MHZ CPU,	
SOFTWARE PUBLISHING	1MB/2MB/4MB MEMORY BOARDS CALL	102-KEY KEYBOARD MS DOS 3.1 CALL	
HARVARD TOTAL PROJECT MANAGER11 369.00	MONITORS	WYSE	
P.F.S. GRAPH/PLAN ea. 89.00	AMDEK 1280 MONITOR 799.00	PC 386 (16MHZ) ZERO WAIT-STATES 1MB	
FIRST CHOICE 119.00	PQS MAX-12 (MONO MONITOR) 189.00	RAM, 1.2MB D/D, KEYBOARD, MS DOS 3.2	
PROFESSIONAL FILE/PLAN ea. 159.00	N E C JC1401 MULTISYNC EGA 569.00	(8MHZ) MODE, SERIAL/PARALLEL PORT... CALL	
PROFESSIONAL WRITE 139.00	SONY CPD-1302 MULTISCAN EGA CALL		
WALLSOFT	DISKDRIVES	THIS AD WAS PREPARED USING	
THE UI PROGRAMMER 249.00	I OMEGA 10+10MB BERNOULLI BOX 1559.00	XEROX VENTURA DESKTOP PUBLISHER	
THE DOCUMENTOR 249.00	I OMEGA 20+20MB BERNOULLI BOX 1995.00	AND PRINTED WITH	
WORDPERFECT CORP	I OMEGA TRI/PAK CARTRIDGES 10MB 179.00	HEWLETT-PACKARD LASER JET SERIES 11	
WORDPERFECT V 4.2 239.00	PLUS DEVELOPMENT 20MB HARD CARD CALL		
XYQUEST XY WRITE 111 V 3.1 275.00	PLUS DEVELOPMENT 40MB HARD CARD CALL		
GRAPHIC & DESK TOP PUBLISHING	SEAGATE ST-225 20MB WITH W/D 319.00		
ALDUS PAGE MAKER 499.00			
DECISION RESOURCES			
CHART/DIAGRAM/SIGN MASTER CALL			

TERMS AND CONDITIONS.

We reserve the right to repair, replace or return to manufacturer for repair, all goods acknowledged faulty or damaged on receipt by customer. Customer Must Call For Return Authorization Number Before Returning Any Goods. Prompt attention will be given to all damaged and faulty returned goods. Any goods returned for credit are subject to 20% restocking charge, plus shipping charge. No Returns For Credit On Any Software. Customer must deal directly with the manufacturer if the customer finds any false claims made by the manufacturer. All goods are shipped VIA U.P.S. ONLY. Shipping charges are 2% of the total purchase price or \$3.00, whichever is greater. Please call for shipping charges on Printers & Accessories. C.O.D. are shipped for Cash or Cashier's Check Only. Max \$1500.00. Please allow 7 to 10 working days for personal or corporate checks to clear. To expedite shipping send money order or cashier's check, or charge to your VISA OR MASTERCARD. WE DO NOT Add a Service Charge For Credit Card Usage. PRICES SUBJECT TO CHANGE WITHOUT NOTICE. NOT RESPONSIBLE FOR TYPOGRAPHICAL ERRORS.

ORIGINAL KEN GORDON PRODUCTIONS - OUR 8TH YEAR!

COMPUTER SHOWS SALES & FLEAMARKETS



HARDWARE - SOFTWARE - SUPPLIES - ACCESSORIES - PARTS - BOOKS
NEW - USED - SURPLUS - CLOSEOUTS - LIQUIDATIONS - SAVE 10-80%

September 12
Saturday 9 to 4
Admission \$7

NORTH JERSEY MICRO SHOW & SALE - 400 Tables
Meadowlands Hilton Hotel - Secaucus, New Jersey
1-Mile East of Giants Stadium off Route 3

October 4
Sunday 10 to 4
Admission \$7

LONG ISLAND MICRO SHOW & SALE - 200 Tables
Grand Royal Hotel - Clinton Ave. - Hempstead, NY
Lots of Free Parking at office building next door

October 11
Sunday 10 to 4
Admission \$7

IBM CLONE SHOW & SALE - No. Jersey - 200 Tables
Aspen Manor - Route 46 West - Parsippany, NJ
Near Interstates 80/280/287 - 20 Mi. West of NYC

December 5
Saturday 10 to 5
Admission \$7

NORTH JERSEY MICRO SHOW & SALE - 500 Tables
William Paterson College - Rec. Center - Wayne, NJ
I-80 to Route 23 North to Ratzer Road to College

SAVE \$1.00 PER ADULT ON ADMISSION / BRING THIS AD

FOR ADDITIONAL INFORMATION OR DIRECTIONS TO SHOW
CALL (201) 297-2526 OR OUTSIDE NEW JERSEY CALL TOLL FREE (800) 631-0062 **BYTE 9/87**

CTX 14" DISPLAY MONITORS



14" RGB COLOR DISPLAYS

- CGA: Resolution 640 x 200
 CTX 1410 .42 Dot Anti Glare
 CTX 1411 .38 Dot Black CRT
 CTX 1421 .31 Dot Anti Glare
- EGA: Resolution 640 x 200 / 640 x 350
 CTX 1422 .31 Dot Anti Glare

SPECIAL

- PRODUCT: CTX 1421LP - Long Persistence
 720 x 480, .31 Dot CRT
- CTX 1424 .39 - Hi-Res 640 x 400
 24 KHZ, .39 Dot CRT
- CTX 1424 .31 - As Above With .31 Dot

**TWO YEAR
WARRANTY!**

CTX 1400

- 14" TTL Monochrome
- 1000 Lines Resolution
- Swivel Tilt Base
- Green or Amber CRT
- Flat Screen Display

OEM, Distributor, Dealer Inquiries Invited.

USA Head Quarter
 CTX International
 260 Paseo Tesoro
 Walnut, CA 91789
 (714) 595-6146
 Fax: (714) 595-6293

Eastern Region
 Continental Technology
 300 McGaw Dr.
 Edison, NJ 08837
 (201) 225-7755

New England
 Micro-Rep (Manufacturer Rep.)
 141 Brooks St., Suite 1
 Brighton, MA 02135
 (617) 783-4877

COMMIX 32: A complete table-top network for PCs and minicomputer hosts. Optional Ethernet and Wide-area link modules, Print Buffer module, and MS-DOS® Network Utilities. Powerful Solutions for Small and Large Networks!

PC Networks: Do you need a PC LAN and multi-user file server, or just advanced communications?

Chances are your company's operations are managed on a mini or mainframe host; PCs are for personal productivity (word processing, spreadsheet analysis, etc.). So the interactive (operations) files reside on the multi-user host and PC users need to conveniently exchange files, share peripherals and access the host. So what do you need in a PC network? You need COMMIX 32, for ease of installation and use, you can't buy anything better! and COMMIX is priced at under \$125 per port.

COMMIX Software Utilities Provide Unsurpassed Productivity

ITRON has added exceptional value to COMMIX 32 with an MS-DOS® software package that includes background file transfer, electronic mail, terminal emulation and printer sharing utilities. The COMMIX utilities are configured and controlled from pop-up menus for ease of set-up and use. The printer sharing utility, CPS, while in background mode, intercepts print requests from DOS applications, rerouting through COMMIX to the printer of your choice. Background file transfer and E-mail utilities serve local and remote users while running most popular applications programs.

Ideal PC-PC and Mini-Host Communications

COMMIX 32 uses the popular "AT" modem protocol for connection command, treating each port or port group as a telephone extension number. This means that popular software such as Crosstalk® or Mirror® can be used to make connections, transfer files, or emulate a terminal when the connection is to a minicomputer host—at up to 19.2 kbps! Wide area calls can be made through an "AT" modem connected to a COMMIX port. The connection command from the PC software appears as an access code in front of the remote telephone number. Remote modem users can call into COMMIX via an attached modem and select any PC, mini-host port, or printer. COMMIX 32 converts speed, async format and flow control set-up parameters as required for each connection. This allows maximum sharing of printers, host computer ports, and PC data for local and remote users. An optional Ethernet link module provides distributed logic switching for larger or multiple host networks. The optional Wide Area link module provides a multi-channel, high speed synchronous bridge to other COMMIX systems or networks.

Mini Host Networks: Port contention and shared peripherals with universal connectivity.

COMMIX 32 is the ideal data switch for multi-user minicomputer hosts, such as the MicroVax®. Advanced switching features allow universal port contention or utilization with convenient printer sharing and modem pooling. COMMIX 32 provides an alternate "native" connection protocol that is convenient for terminal users. Port class and auto-queue features for port/peripheral contention provide additional functionality. An optional one megabyte print spooler module, managing two printers, frees your computer from print job delays. Other features, such as built-in diagnostics with fault reporting and console control of the network with statistical reporting, make COMMIX 32 your best PC network solution.

Call our toll free number for complete information today!

P.S. Yes, we do have a nationwide field service organization!



130 Gaither Drive
Suite 116
Mount Laurel, NJ 08054

(800) 423-8044
(609) 722-5575

COMMIX 32—Under \$125 per Port

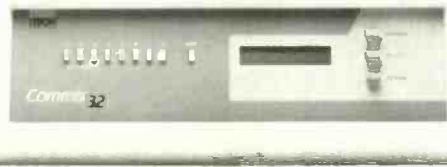

Universal Connectivity

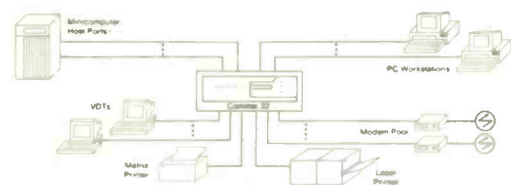

Standard or Thir Ethernet Links

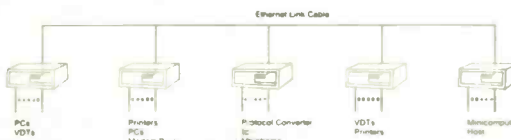

Data Switching Features

- Up to 32 async ports
- Expandable user I/O in 4-port module increments
- Port rates (ABR and preset) to 19.2 kbps
- Speed and async format conversion
- Flow control, selectable as bit-based or EIA signal type
- EIA control signal handshaking
- Local echo, selectable at any port
- Stored virtual circuits, and virtual call connections
- Camp-on queue for port contention
- Port class feature, allowing user to define one address for any of a group of ports
- Inactivity timeout, user selectable and programmable from 10 to 60 minutes
- Call/connection status screen
- Password security facilities, two levels
- Diagnostic facilities for port and link loopbacks, and test pattern generation to verify interfaces
- Optional synchronous channel module
- I/O interface compatible with popular modular wiring system for neat, versatile and highly functional premise wiring

Easy Installation—No Bulky Cables

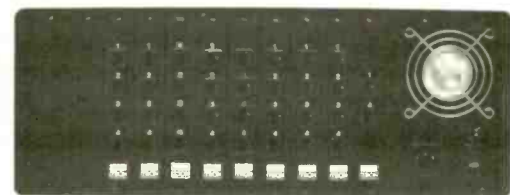

MS-DOS, Crosstalk, Mirror and MicroVax are registered trademarks of Microsoft, Inc., Digital Communications Associates, Inc., Software Distribution Corporation, and Digital Equipment Corporation respectively.

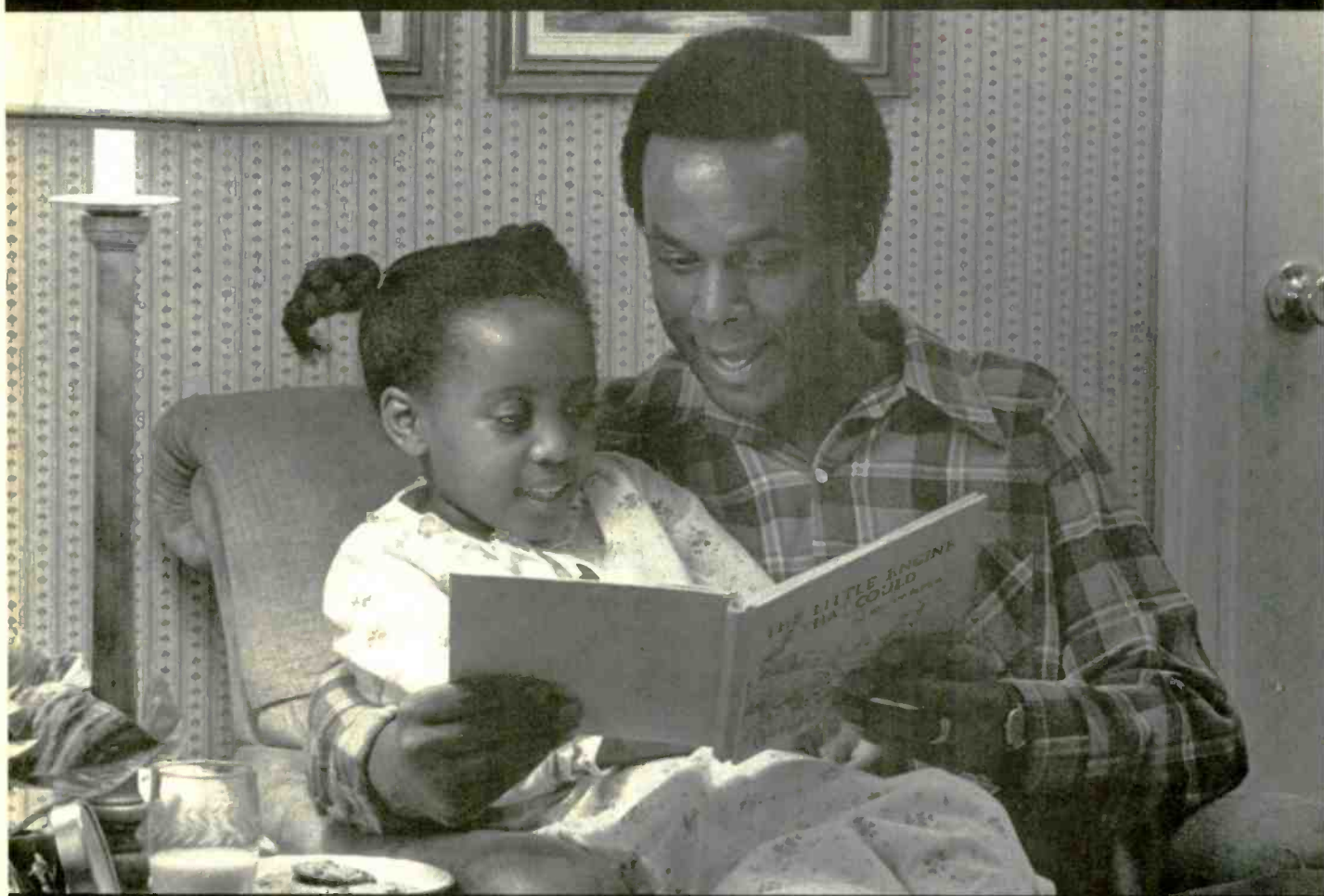

To 27 million Americans, this scene is a fairy tale.

That's because 27 million American adults can't read a child's bedtime story, can't read a street sign, can't read...period.

Functional illiteracy has become an epidemic, an epidemic that has reached 1 out of 5 American adults. It robs them of a decent living, it robs them of self-respect, it robs them of the simplest of human pleasures...like reading a letter from a friend or a fairy-tale to their children.

Tragic as that is, it's not the worst part. Because people like this could be taught to read, if we had more tutors to teach them. Sadly, we don't. Today, the waiting period for a tutor can be up to a year.

You can change that by joining the fight against illiteracy yourself. It takes no special

qualifications. If you can read, you can tutor or help us in countless other ways: You'll be trained to work in programs right in your own community. And you'll experience the greatest satisfaction of all...the satisfaction of helping people discover whole new lives.

So join the effort. Call the Coalition for Literacy at toll-free **1-800-228-8813**. Helping takes so little. And illiteracy robs people of so much.

**Volunteer Against Illiteracy.
The only degree you need
is a degree of caring.**

**Ad
Council**

 Coalition for Literacy

Our People and Technology make the Difference!

COMPUTER LIBRARY - SERIES 1800

8MHz 1 Wait State
10MHz 1 Wait State
10MHz 0 Wait State

**CALL
FOR LOW
PRICES**



STANDARD FEATURES

- Intel 80286 - 10MHz CPU
- Custom Written AMI BIOS
- 512K RAM Expandable to 1MB
- Dual Hard Disk/Floppy Controller
- Teac 1.2MB Floppy Drive
- AT style Keyboard
- 192 watt power supply
- Clock/Calendar with battery back up
- Complete Reference Manual
- Set up Utility Software

SERIES 1800 8/10MHZ 1 W/S SYSTEM PACKAGES

	8MHz	10MHz
• MONOGRAPHIC SYSTEM	\$899	\$1089
• MONOGRAPHIC WITH 20MB HD	\$1299	\$1389
• MONOGRAPHIC WITH 30MB HD	\$1559	\$1649
• EGA COLOR SYSTEM	\$1399	\$1489
• EGA COLOR WITH 30MB HD	\$1859	\$2049
• EGA COLOR WITH 40MB HD	\$2089	\$2179

ACCESSORIES

• 360K Floppy Drive	\$95
• 512K Memory	\$64
• Enhanced Keyboard Upgrade	\$35
• 80287-8 Math Co-processor	\$235
• MS DOS 3.2 + Basic	\$89
• Mini I/O Card	\$59
• Multifunction Card (0-2MB)	\$175
• 3MB Memory Card (0-3MB)	\$150

Made in
USA

COMPUTER LIBRARY INC.

(415) 659-8784 Sales

(415) 659-8887 Tech Support

42624 Christy Street
Fremont, CA 94538

8MHz TURBO XT SYSTEM

\$399



- Fully IBM compatible
- 4.77 & 8MHz Keyboard Selectable
- 360K Floppy Drive
- Floppy Drive Controller
- 256K Memory expandable to 640K
- Optional Math Co-processor
- 150W power supply
- AT style Keyboard

TURBO XT SYSTEM PACKAGES

• MONOGRAPHIC SYSTEM	\$560
• MONOGRAPHIC WITH 20MB HD	\$910
• COLOR GRAPHIC SYSTEM	\$740
• COLOR GRAPHIC WITH 20MB HD	\$1090

ACCESSORIES

• 360K Floppy Drive	\$85
• 8087 Math Co-processor	\$159
• 256K/64K RAM (9 pcs)	\$32/\$12
• Enhanced Keyboard Upgrade	\$35
• Mini I/O Card	\$59

OTHERS

• DOS 3.1	\$49
• MS DOS 3.2 + GW BASIC	\$89
• Everex 1200 Baud Modem	\$99
• Everex 2400 Baud Modem	\$189
• Everex 60MB Tape Backup INT/EXT	\$757/\$827
• Monographic Card	\$89
• Colorgraphic Card	\$89
• EGA Color Card	\$169
• NEC Multisync Monitor	\$599
• FUJITSU 360KB Floppy Drive	\$85
• TEAC 360KB Floppy Drive	\$95
• TEAC 1.2 MB Floppy Drive	\$136
• HD/Floppy Controller for AT	\$185
• Enhanced Keyboard AT/XT	\$89
• AT 10MHz Motherboard	\$450
• XT 8MHz Motherboard	\$145
• 150 Watt Power Supply	\$79
• CITIZEN 120D Printer	\$209

INTRODUCTION
SPECIAL

386 SYSTEM

\$2995

- Fully Compatible with COMPAQ 386
- Intel 80386 CPU - 16MHz
- Phoenix 386 BIOS
- Four Speed Selection - 16, 8, 6, 4.77MHz
- 1MB RAM Installed expandable to 10MB
- Eight expansion slots
- Compatible with 8MHz 80286 hardware and software



HARD DISK SUBSYSTEMS



• 20MB Seagate ST-225 w/controller (65 ms)	\$299
• 30MB Seagate ST-238 w/controller (65 ms)	\$329
• 20MB Seagate ST-4026 (40 ms)	\$549
• 30MB Seagate ST-4038 (40 ms)	\$529
• 40MB Seagate ST-251 (40 ms)	\$549
• 40MB Seagate ST-4051 (40 ms)	\$699
• 72MB Toshiba MK-56 7B (25 ms)	\$995
• 80MB Seagate ST-4096 (28 ms)	\$995

Call us about
our leasing program.

Seagate, Hercules, Hayes, Compaq, IBM are registered trademarks of their respective companies.



Terms: We accept MasterCard, Visa (3% surcharge), COD (Cashier check, cash, or approved check), Company/Institutional P.O. For returns and repairs, call for RMA number. A 15% restocking on all unauthorized returned items. No credit issued after 30 days from date of shipment. Copies of original sales order must accompany any return. Price subject to change.

"...Among the best of the data base management systems."

-BYTE Magazine, Nov. '86

- Powerful
- Easy-to-use

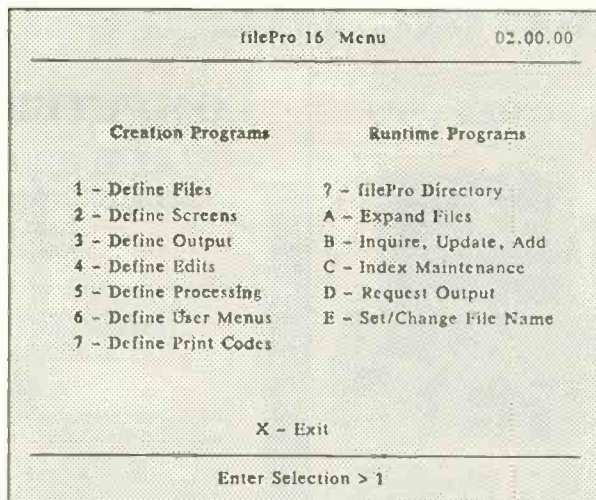

- Menu Driven
- User Friendly

● Not Copy Protected

In today's business environment, you need a system that adjusts to change fast. *filePro 16* is a flexible, easy-to-learn package you can build on. Start with a simple mailing list and design your way up to full accounting and inventory systems.

OVER 200,000 USERS WORLDWIDE



The Small Computer Company Inc.

41 Saw Mill River Road, Hawthorne, NY 10532, (914)769-3160

The Key Tronic 101. All Keyed Up And Ready To Go.

Here's a keyboard that's so reliable, it's backed with a three-year warranty.

The KB 101 has all the enhancements you want, plus the quality that has made Key Tronic the world's leading independent manufacturer of keyboards.



Best of all, it's available for immediate delivery.

The KB 101 works with standard and enhanced PCs, XT's, AT's and most compatibles. So it's the perfect choice for organizations that want to standardize on one board.

It also features a separate cursor and numeric pad for greater speed and accuracy in word processing and spread sheet operations.

The KB 101 from Key Tronic. It's your key to greater productivity.



SSE PRODUCTS INC.

791 Meacham Avenue, Elmont, N.Y. 11003

(516) 872-9001, (800) 632-2444

key tronic

The *Responsive* Input Company

The Key Tronic 101 Keyboard

SAVE 15%

on these new computer books and software from McGraw-Hill
CALL TOLL-FREE 1-800-2-MCGRAW

INTRODUCING PC-DOS AND MS-DOS

By T. Sheldon. 374 pp., illus., softbound Find out about the free advanced capabilities of DOS and how to use them. "Wonderfully enlightening . . . well-written . . . my pick for technical book of the year."—*Online Review* 056559-7. Regular Price: \$18.95. **Your Price: \$16.10.**

INTRODUCING UNIX™ SYSTEM V

By R. Morgan & H. McGilton. 480 pp., illus., softbound Guides you step by step through the facilities, commands, utilities, and applications of System V, AT&T's new version of the UNIX operating system. 043152-3. Regular Price: \$19.95. **Your Price: \$16.95.**

UNIX™ UTILITIES: A Programmer's Guide

By R. S. Tare. 640 pp., illus., softbound Save time and effort with popular UNIX utilities! Helps you write efficient, bug-free programs and significantly reduce turnaround time. 062884-X. Regular Price: \$24.95. **Your Price: \$21.20.**

HOW TO BE A SUCCESSFUL COMPUTER CONSULTANT

By A. R. Simon. 256 pp., illus., softbound Everything you have to know to set up and run your own computer consultant (or software development) business, full- or part-time. No business experience required! 057296-8. Regular Price: \$18.50. **Your Price: \$15.70.**

dBASE DEMYSTIFIED: dBase II/III/III Plus™ Applications and Solutions to Real Problems

By L. Barnes. 288 pp., 120 illus., softbound Covers the full range of dBase features and shows how to apply the various releases of dBase to real-world problems. 003844-9. Regular Price: \$19.95. **Your Price: \$16.95.**

BUILDING YOUR FIRST EXPERT SYSTEM

By T. Nagy, D. Gault, & M. Nagy. 293 pp., book/disk (IBM PC and compatibles) How to easily create your own working expert system. A book/disk combination ideal for beginning programmers. 912673-1. Regular Price: \$19.95. **Your Price: \$16.95.**

GETTING THE MOST OUT OF YOUR EPSON PRINTER

By D. A. Kater & R. L. Kater. 224 pp., 170 illus., softbound The A to Z of the popular Epson printer and how to make maximum use of it. Covers the full line. 033385-8. Regular Price: \$19.95. **Your Price: \$16.95.**

dBASE III PLUS™ TRAIL GUIDE

By H. Dickler. 350 pp., book/disk (IBM PC and compatibles) Follow this step-by-step trail and learn dBase III Plus in one week! With valuable programs you can modify and use over and over again. 912709-6. Regular Price: \$29.95. **Your Price: \$25.45.**

A COMPREHENSIVE GUIDE TO AI AND EXPERT SYSTEMS

By R. I. Levine, D. E. Drang, & B. Edelson. 256 pp., 99 illus., softbound All about artificial intelligence and how to utilize it on your personal computer. Gives you everything from basic concepts to sophisticated programming techniques. 037470-8. Regular Price: \$19.95. **Your Price: \$16.95.**

MICRO-EXPERT

By B. Thompson & W. Thompson. 74 pp., book/disk Become an instant expert with the world's most widely used expert system shell. Includes its own source code so you can tailor it to meet your needs. "Highly recommended."—*Online Today* IBM PC (and compatibles): 852109-2. Apple II (all models): 852110-6. Apple Macintosh: 852138-6. Regular Price (all versions): \$49.95. **Your Price: \$42.45.**

For fast service call TOLL-FREE
1-800-2-MCGRAW or use coupon below. 15-day
examination period.



McGraw-Hill Book Company
P.O. Box 400, Hightstown, NJ 08520

Please send me—at 15% off the regular price—the products whose code numbers (the number before the regular price in above blurb) I have checked below. I understand I have 15 days for free examination before I send payment for those products I want to keep (plus postage, handling, and local tax) and return any unwanted products postpaid.

- | | | |
|---|---|---|
| <input type="checkbox"/> 056559-7 \$16.10 | <input type="checkbox"/> 003844-9 \$16.95 | <input type="checkbox"/> 037470-8 \$16.95 |
| <input type="checkbox"/> 043152-3 \$16.95 | <input type="checkbox"/> 912673-1 \$16.95 | <input type="checkbox"/> 852109-2 \$42.45 |
| <input type="checkbox"/> 062884-X \$21.20 | <input type="checkbox"/> 033385-8 \$16.95 | <input type="checkbox"/> 852110-6 \$42.45 |
| <input type="checkbox"/> 057296-8 \$15.70 | <input type="checkbox"/> 912709-6 \$25.45 | <input type="checkbox"/> 852138-6 \$42.45 |

Name _____

Address _____

City _____ State _____ Zip _____



FREE!

Electronics... The Magazine That Gives You Technology With Perspective.

There's simply no other magazine like Electronics! It brings to your desk the comprehensive coverage and perspective you need, no matter what your job or responsibilities are. Electronics provides you with technical information on computers, data processors, peripheral equipment, office and business machines, communications equipment and semiconductors. Information that keeps you abreast of industry breakthroughs, trends and business directions. It gives you the savvy needed to compete.

Each issue focuses in on the meaningful technological developments and concerns driving the electronics industry.

Why Is Electronics Free to Professionals Like You?

By controlling circulation, we make our readership fit our editorial. Editorial for important people, like you, who need the important information only Electronics provides.

And it's yours, FREE...if you qualify. Simply fill out and return the adjacent card. If you qualify, we'll start your subscription with the very next issue of Electronics.



Electronics





The Micro Clipper Graphics Subsystem

Charles Weston

High-end graphics performance for your PC-based CAD application

Graphics performance has been the traditional stumbling block to truly productive IBM PC-based CAD systems. Specifically, the problems with running popular packages, such as AutoCAD, are low screen resolution and poor graphics throughput. However, at least one solution is now available.

Micro Clipper Graphics from Pixelworks (\$3295) is a two-board graphics subsystem for the IBM PC AT, RT, and compatibles that typically improves AutoCAD graphics performance by 5 to 10 times. The subsystem provides enhancement functions, such as continuous real-time pan and zoom and a split-window display. It also operates with other popular CAD packages, including EasyCAD, Personal Designer, and VersaCAD.

The subsystem features a 66-MHz internal clock, pipelined architecture, and direct memory access (DMA) to a locally generated graphics-display list.

It supports a "multisync" mode of 720 by 560 pixels with 4-bit planes, a 1020- by 816-pixel 4-bit-plane mode (these modes both provide 16 colors from a palette of 4096), and emulation of IBM CGA and EGA. The subsystem uses a 9-conductor NEC MultiSync-type (9-pin D to 9-pin D) cable. An optional jumper is available for CGA or EGA pass-through, allowing you to route your CGA or EGA adapter's signal through Micro Clipper Graphics to avoid switching monitor cables whenever you want to use your standard display adapter. Unfortunately, although you can use Micro Clipper Graphics as a CGA or EGA adapter, you have to manually toggle a switch on the board.

The Micro Clipper Graphics subsystem requires a host computer with two adjacent 16-bit slots (like those on an IBM PC AT or RT PC), 22.5 watts of 5-

volt power, and a 60-hertz noninterlaced 3-wire RGB monitor, such as the NEC MultiSync. All CAD programs recommend, and some require, a math coprocessor. RAM requirements vary, depending on the CAD package. Generally, you'll need enough RAM to satisfy not only the CAD software's basic needs, but also about double the amount of RAM you would normally need for the display list. This means that if you're processing 250K-byte AutoCAD drawings, at least another half megabyte of RAM is required. AutoCAD specifies a minimum of 512K bytes of RAM, but as the program "pages" a drawing from disk into RAM, the more memory you have, the more efficiently your system will run.

Pixelworks also offers a big brother to Micro Clipper Graphics, called Clipper Graphics (\$4500), that is designed pri-

marily for three-dimensional use. It has a 119-MHz clock, resolution of 1024 by 1280 pixels, and 256 simultaneous colors from a 4096-color palette. A 16.7-million color palette is available as an option. Its special three-dimensional functions include rotation, translation, perspective, and shading.

I evaluated Micro Clipper Graphics on a TeleVideo Tele-CAT-286⁸ equipped with an 8-MHz 80286 processor, 2 megabytes of RAM, an 80287 math coprocessor chip, a 30-megabyte hard disk drive, and an NEC MultiSync monitor.

Inside the Graphics Engine

The most interesting component of the Micro Clipper Graphics subsystem is the graphics engine. Its primary function is to manipulate "transformed vectors," which are the definitions of lines based on a coordinate system. The graphics engine accomplishes all scaling, rotation, zooming, and panning by matrix multiplication of these vectors.

A bus interface processor on the subsystem communicates with the host computer's bus. This processor is responsible for DMA, using a 16-bit DMA channel in Cascade mode to access nonsequential addresses. To increase the overall processing speed, Micro Clipper Graphics becomes the bus master, sourcing the addresses necessary to get the display-list data. (CAD drawing data is stored in hierarchical tree structures throughout the memory space.)

A display-list processor interprets the

continued

Charles Weston is a BYTE technical editor. He can be contacted at BYTE, One Phoenix Mill Lane, Peterborough, NH 03458.

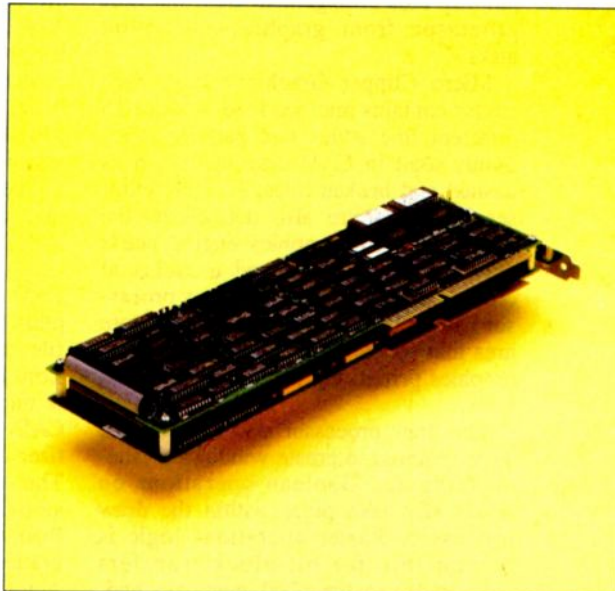

Micro Clipper Graphics**Type**

Graphics subsystem

Company

Pixelworks Inc.
225A Lowell Rd.
Hudson, NH 03051
(603) 880-1322

Size

Two 13½- by 4¾-inch boards; weight:
2 pounds

Features

Ten enhanced CAD functions, including Autopan and Zoom; CGA- and EGA-emulation modes; split screen; writable control store for user-defined graphics primitives; line, polyline, rubber-band, and drag support; 16 simultaneous colors from a palette of 4096; support for AutoCAD, VersaCAD, and other popular CAD packages; third-party software support for the GKS standard and Tektronix and DEC terminal emulation; comes with Pixelworks' drivers and diagnostics on two 5¼-inch floppy disks.

Hardware Required

IBM PC AT, RT, and compatibles with at least 512K bytes of RAM, a hard disk drive, and an NEC MultiSync-type RGB monitor capable of 720- by 560- or 1020- by 816-pixel resolution; math coprocessor and extra memory recommended

Software Required

MS-DOS or PC-DOS 3.0 or higher or GEM plus CAD application software package

Documentation

29-page user's manual

Price

\$3295

data coming from the DMA channel. The data can be of two types: branches (conditional or unconditional), which are based on some status change dictated by the drawing operation, or graphics commands (e.g., points, lines, and arcs), which are control points within a "modeling space." A modeling space can best be described as a virtual drawing. The modeling space on Micro Clipper Graphics theoretically can comprise 32,000 by 32,000 addressable points.

The control points interpreted by the display-list processor are then fed through the graphics engine's transform-and-clip processors, where they are translated from virtual-drawing coordinates to "screen-space" coordinates. The

screen space on Micro Clipper Graphics is 1020 by 816 pixels, but the actual display window for the NEC MultiSync comprises only 720 by 560 pixels.

The 720- by 560-pixel display-window area is actually a translated subset of the virtual drawing. The drawing is represented as a vector list, which describes the 32,000 by 32,000 points. To translate the vector list to the screen image, Micro Clipper Graphics multiplies the coordinates by a scale plus an added offset and then clips the image to the screen boundaries.

Without Micro Clipper Graphics, a CAD system running with a CGA, EGA, or other standard graphics interface forces the microprocessor to do all the vector computation. Micro Clipper Graphics, however, has a floating-point package implemented in microcode on the subsystem for doing the vector calculations. This arrangement frees the host processor from graphics-calculation tasks.

Micro Clipper Graphics's draw processor contains microcode to produce 16 different line styles and patterns commonly used in CAD drawings, such as dashed and broken lines. Circles, ellipses, and arcs are also defined by the microcode. The graphics engine needs only the center point and a radius to create arcs and circles. The draw processor has a 32K-byte writable control-store area that you can load with user-defined graphics primitives, such as custom text fonts.

The draw processor also contains the logic required to create windows. Plane-masking and Boolean operations on pixels also take place within the draw processor. Raster-operations logic is responsible for bit-block transfers (BIT/BLTs) to the pixel memory, and, ultimately, to the screen. The pixel memory contains the video RAMs that store the screen-space image, which is rasterized in the last stage of the viewing pipeline by the high-speed D/A converter (a Brooktree BT451 RAMDAC chip).

All text generated by the graphics engine is "stroke text"; that is, text made up of vectors arranged in head-to-tail fashion that compose the individual letters. This type of text has the advantage of being easier to scale and rotate than pixel-oriented fonts. To rescale the text, the graphics engine merely rescales the matrix of the endpoints that define the characters. Similarly, the graphics engine can rotate text—a time-consuming process with pixel-oriented text.

Panning Around

Before using Micro Clipper Graphics, you must configure the switches and

jumpers on the subsystem board set. I altered my system configuration to allow routing of the CGA/EGA board signals through the Micro Clipper Graphics subsystem to my MultiSync monitor.

The two high-end graphics resolutions are switch-selectable, and the DMA channel is jumper-selectable. Normally, the graphics subsystem uses DMA channel 6, but you can select channel 7 and change the corresponding interrupt vector by switch-selection to avoid conflicts with other boards in your system. Setting the switches and connecting the factory-supplied feed-through cable was no problem. I also ran the factory-supplied TESTME diagnostic, which indicated that the boards were functioning properly. I encountered difficulty in configuring AutoCAD and the software, however.

First, you must delete the ACAD.MNX and ACAD.MNU files from the AutoCAD directory and rename the Pixelworks ADI (AutoCAD device interface) driver file, which corresponds to your memory model, as DSCLIPPER.EXE and then add it to the directory. I used a simple 640K-byte nonextended memory model for this.

The next file that you need to copy into the AutoCAD directory is Pixelworks' DSCLIP.MNU. You must rename this file ACAD.MNU to replace the original AutoCAD menu file with it. AutoCAD compiles this file into a smaller executable file, called ACAD.MNX, which contains the icons that appear at the lower right corner of the screen. Then you enter the AutoCAD configuration and the type of digitizer used; I used a Logitech C7 Mouse. The version of AutoCAD that I used, version 2.6, contains the option for the Pixelworks ADI driver file in the configuration menu, and, once I selected it, AutoCAD came up in 720- by 560-pixel resolution with the six extra menu items that appear on the right edge of the AutoCAD display.

In short, installing Micro Clipper Graphics for use with AutoCAD is not for the fainthearted. The Pixelworks disks supplied with the subsystem contain the necessary software, but the user's manual is not explicit about the actual installation. According to Pixelworks, software-installation support is the responsibility of the application vendor. Nonetheless, Pixelworks has a hotline to call for troubleshooting information, and I made good use of it.

New Level of Functions

Micro Clipper Graphics adds a level of functions that are completely resident in the subsystem's hardware, and the CAD application software has no knowledge of

continued

WHO YA GONNA CALL? BUGBUSTERS!

This is how PROBE displays real-time trace data. Trace information includes C source code, assembly language and data which was read or written during instruction execution. PROBE software simplifies the display by tossing out prefetched but unexecuted instructions.

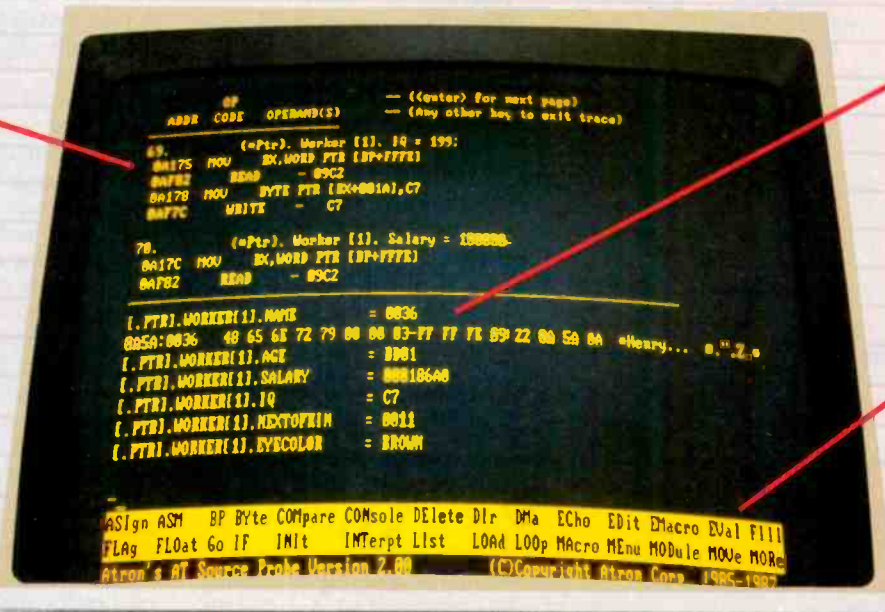

PROBE knows all about your local and complex variables. You can display and change an array of structures as easily as shown in this display.

PROBE's menu window means you do not have to look up debug commands in the manual. Entering the command name shows you command syntax.

"Real-time source-level debugging of very large programs simply can't be done without Atron's AT PROBE."

Ed Oates, Director of PC Software Development, Oracle Corporation

The good news with your new Microsoft 4.0 or Lattice* C compilers is that they're providing more symbolic debugging information than ever. The bad news is you can't fit your program, a software debugger and that monster symbol table into memory - at least at the same time.

The great news is that Atron's AT PROBE™ hardware-assisted software debugger not only has 1-MByte of onboard memory for debugger and symbol table, but it now supports local variables and complex data types.

The AT PROBE is a debugging tool that plugs into your PC AT and monitors everything the processor is doing. In real time.

REAL TIME DEBUGGING. SOONER OR LATER, YOU KNOW YOU'LL NEED IT.

The AT PROBE's hardware-assisted breakpoints trap on reading, writing, executing, inputting and outputting. On single or ranges of addresses, including particular variable values. All in real time. For a mere software debugger to attempt this, a 1 minute program would take 5 hours to execute.

OPTIMIZED CODE - GOOD, BAD AND UGLY

The good news is optimizing compilers generate very tight code. The bad news. The time to debug optimized code is inversely proportional to the quality of the optimizer. Figuring out how in the world you ended up somewhere gets ugly, fast.

With AT PROBE's real-time trace capability, program execution history is saved on-board, in real time. Once a hardware trap has occurred, PROBE displays the program execution in detail, including symbols and source code. Real-time trace can show you how out-of-range pointers got that way. And there's really no other way to debug interrupt-driven code.

AT PROBE OPTIMIZES THE OPTIMIZED

When the job of bugbusting is done, your AT PROBE becomes a performance analyzer. So you can have both reliability and performance. So you can send only the best software into the field.

CALL TODAY FOR YOUR FREE BUGBUSTING MANUAL

Nine of the top ten software packages were debugged using Atron tools. Our complete tutorial on state-of-the-art bugbusting is yours, free. Full of examples and illustrations, it will show you how to become a bugbuster yourself.

Call today. Bust bugs tomorrow.



BUGBUSTERS

A division of Northwest Instrument Systems, Inc.
20665 Fourth Street • Saratoga, CA 95070
408/741-5900

Inquiry 21

*Soon to be supported. Copyright © 1987 by Atron. AT PROBE is a trademark of Atron. IBM and Oracle own numerous registered trademarks.

Table 1: Benchmark results; all times are in seconds. Anomalies in timings for some tests, such as the $\times 25$ zoom, are due to the ability of high-resolution graphics boards to capture more detailed information in Zoom mode. Thus, more time is required to draw these images than would be expected.

AutoCAD nozzle drawing	QuadEGA + (CGA) (320 by 200 pixels)	QuadEGA + (EGA) (640 by 350 pixels)	Micro Clipper Graphics (720 by 560 pixels)	Clipper Graphics (1280 by 1024 pixels)
Redraw	1.25	1.58	0.267	0.320
$\times 5$ zoom	0.77	1.22	0.245	0.295
$\times 25$ zoom	0.51	0.64	0.228	0.273
PCB layout				
Redraw	13.95	16.59	1.92	2.15
$\times 5$ zoom	4.09	6.24	1.84	2.03
$\times 25$ zoom	2.60	3.03	2.04	2.22
CADSource Shootout drawing				
Redraw	9.65	15.08	1.15	1.33
$\times 5$ zoom	5.88	8.27	0.86	1.05
$\times 25$ zoom	5.25	6.84	0.53	0.64

whether any of the functions has been invoked, or even that they exist. Zooming in AutoCAD with Micro Clipper Graphics occurs entirely inside the graphics engine of the subsystem.

A small window in the upper left corner of the screen displays a scaled version of the complete drawing being edited with its own cross-hair cursor. The cursor position in the small window corresponds to the position of the working cursor. In Zoom mode, a lightened transparent block within the small window shows you where you are working in relation to the complete drawing. The level of detail in $\times 25$ zoom makes it difficult to see where you are without this indicator.

To change the zoom level, you use AutoCAD's Control-L command. Micro Clipper Graphics traps the command and controls the zoom from the graphics engine. Control-L steps continually among three zoom factors. The first time the function is invoked, the graphics subsystem will execute a $\times 5$ zoom; the next time, a $\times 25$ zoom; and the third time, a $\times 1$ zoom (a return to the original drawing scale). A zoom is not a pixel replication, but a total recalculation and scaling of the individual lines' endpoints described by the clipping rectangle.

The six "local" commands (so named because they execute on the subsystem) are AUTOPAN, ZMALL, SPLIT, SIZE, CLEANUP, and REDRAW. The most useful of these added features is AUTOPAN. In Zoom mode, you simply use the mouse to move the cross hair and the transparent window around the scaled drawing in the small window, and the rest of the screen displays a panorama of the drawing at the

zoomed magnification practically as fast as you can move the mouse.

The ZMALL function redraws the original picture without zooming or panning. SPLIT toggles the small window that displays the scaled drawing. The SIZE function prints out the current number of display-list pages in use at the bottom of the screen. The CLEANUP command erases all unnecessary dots, such as those for control points for circle and arc centers. The REDRAW function redraws an image. Although AutoCAD already has a REDRAW command, the function added by Micro Clipper Graphics is performed quickly by the subsystem.

Other functions offered by Micro Clipper Graphics include ZMWIND, LPAN, and LDRAG. The ZMWIND function, which you invoke from the command line, defines the zoom area, and it simplifies the DEF-WIND implementation in AutoCAD. The first selection of ZMWIND, done with the mouse or the cursor, sets the start corner of the area, or block, to be zoomed, and the second selection sets the opposite corner. The area is then enlarged to fill the entire view window of AutoCAD.

LPAN pans the screen to the current cursor position shown in the small window. LDRAG drags the current zoom window to a new point on the screen. LDRAG works whether the small window is in use or not, so you can zoom around a drawing even if you don't know the precise cursor position in relation to the complete drawing.

Graphics Performance

Graphics system performance is not easy to assess; comprehensive benchmarks for

graphics systems are still being evaluated and debated. The performance of Micro Clipper Graphics can best be measured by using some actual AutoCAD drawings. For the benchmark drawings, I selected the well-known AutoCAD nozzle drawing, a printed circuit board layout from The Great SoftWestern Company, and the CADSource Shootout (a drawing specifically designed to exercise CAD functions).

The tasks I timed were a redraw, a $\times 5$ zoom, and a $\times 25$ zoom. I created a script-command file and used AutoCAD's timing function to calculate the elapsed times for doing the assigned benchmark tasks. The script-command file started the AutoCAD timer, executed 100 iterations of each test function using the AutoCAD nozzle drawing, and then stopped the timer. I conducted the same tests using the CADSource Shootout and the printed circuit board layout, but I executed only two iterations because of the time required. I then divided the total elapsed time by the number of iterations to determine the time required for one iteration. The benchmark results of the AutoCAD system running on my Tele-Video TeleCAT-286⁸ with a Quadram QuadEGA + board in both CGA and EGA modes, with Micro Clipper Graphics, and with Clipper Graphics, are shown in table 1.

Time Caveats

The benchmark times for the CGA and EGA modes of the QuadEGA + board are close to those of the Micro Clipper Graphics subsystem for some of the zoom tests, but these results can be misleading. Due to the lower resolution of the CGA and EGA graphics modes, there is not much detail in the zoomed image, and therefore the images are drawn relatively fast. However, the lack of detail in a 320-by-200-pixel $\times 25$ zoomed image renders the drawing useless for all practical purposes—there are just not enough pixels to accurately represent the information. The slower-than-expected zoom times for Micro Clipper Graphics and Clipper Graphics is caused by the subsystems' higher resolution, which provides more detail than the CGA and EGA modes; the greater the number of pixels, the more processing required.

Overall, the benchmark tests show that the Redraw speed of Micro Clipper Graphics is several times faster than that of AutoCAD running with a math coprocessor. In addition, while its price at first seems prohibitive, the Redraw speed, enhanced resolution, and the ease with which you can zoom and pan around drawings makes Micro Clipper Graphics a useful graphics enhancement tool. ■

AutoSketch™

A Resource to Draw Upon



To get any job done, you need the right tools. Ideally, they should be extensions of your talents, freeing you to do what you do best. And speed, precision, flexibility, and consistency are always top priorities, no matter what the job. If communicating with drawings is part of your job, AutoSketch should be one of your resources.

AutoSketch from Autodesk, the developers of AutoCAD® is the precision drawing tool for professional use. It's fast, powerful, and simple to learn. The price is right, too.

With AutoSketch and your personal computer, you'll enter the world of computer-aided drawing with ease. You may never have designed with a PC before, and you may think it's bound to be complicated and time-consuming. Surprise! With AutoSketch, you'll probably be up and running in about an hour.

Despite its ease of use, AutoSketch is a full-function, object-oriented CAD program. Pull-down menus and dialog boxes help you each step of the way. With a click of the mouse, you can draw, then copy, mirror, or move objects, even create symbol libraries. AutoSketch automatically updates measurements whenever you stretch, scale, or rotate dimensioned objects. It even keeps track of everything you do, so that you can delete and restore parts of your drawing as easily as you change your mind, using successive undo or redo commands.



We know you'll be impressed with the professional results. So will your clients and colleagues.

AutoSketch runs on the IBM PC/XT/AT and compatible systems with a minimum of 512K RAM and either color or monochrome display. The standard version is yours for just \$79.95. If your PC has an 8087 or 80287 math coprocessor, this version operates about three times faster. The speed-enhanced version for \$99.95, requiring the coprocessor, is three times faster still.

Call 800-445-5415 for the name of the AutoSketch Dealer nearest you or more information on supported peripherals. To order direct with a credit card, call 800-772-9200, ext. 347.

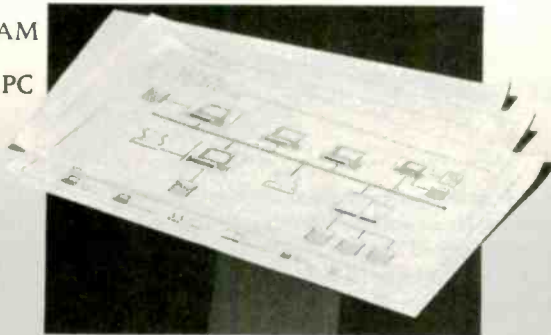

Touch all the bases.

Databases, that is.

Exactly the ones you need to remain competitive in a rapidly changing marketplace. Our magazine is here to coach business professionals in the online skills. Because tapping into the exciting new sources of business information can be the move that keeps you one step ahead of the competition.

It's a guaranteed way to put runs on the board. So whether you're a rookie in the online game or a veteran with years of experience, let *Online Access* magazine help make winning a little easier.

Touch all the bases.
With *Online Access*.

Call 800.922.9232
and subscribe today.

ONLINE ACCESS

The Gateway to Business Information



Yes, I want the power of online information at my fingertips. Please send me a 1-year subscription to *Online Access* for \$24.95. If ever I'm not satisfied with my subscription, I'll let you know – and will receive a refund on all unmailed issues.

Please bill me
Payment enclosed

Online Access
53 W. Jackson Blvd., Suite 1750
Chicago, IL 60604

Name

Company

Title

Address

City

State

Zip

U.S. funds only. Canadian residents add \$6.00.

TAB X



PC-MOS/386

Richard Grehan

A DOS-compatible multitasking, multiuser operating system for 80386-based hardware

PC-DOS just isn't cut out as an 80386 operating system, and new OSs are trickling out in an effort to fill the gap. One of the early arrivals is The Software Link's PC-MOS/386. Its design is ambitious: PC/MOS-386 attempts to retain compatibility with PC-DOS while adding a host of multitasking and multiuser capabilities, plus the ability to run protected-mode 80386 applications when they become available.

These goals, though, fall short in the execution. I tested PC/MOS-386 release 1.01 on two Compaq Deskpro 386s: one with an 80287 coprocessor, 2 megabytes of RAM, and a 20-megabyte hard disk drive, and the other with an 80387 coprocessor, 4 megabytes of RAM, and a 40-megabyte hard disk drive. In addition to a five-user version (\$595), PC-MOS/386 comes in two other forms: a single-user version (\$195) and a 25-user version (\$995).

A Promising Start

Installing PC-MOS/386 is as painless as it gets. I simply inserted the master disk in the floppy disk drive, booted the system, ran HDSETUP (analogous to PC-DOS's FDISK) to create a PC-MOS partition on the hard disk, ran FORMAT to format the hard disk, executed .MSYS C: to write boot information on it, and copied three files to it to get a bootable PC-MOS drive. The manual guided me step-by-step through all this, and I encountered no problems in getting the system operational.

Since PC-MOS lets you create a logical drive of up to 256 megabytes, I was able to use the entire 40-megabyte drive on one machine. PC-MOS has no trouble reading standard PC-DOS 360K- and 320K-byte floppies, so transferring files onto the hard disk was simply a matter of using the COPY command.

All the commands in PC-DOS for creating, deleting, copying, and renaming files and directories are available in PC-MOS/386, and most of them use the

same syntax. I found some differences that led to momentary confusion; for example, the PC-DOS CHKDSK command is called VERIFY in PC-MOS/386, and PC-DOS's VERIFY command is called WVER.

PC-MOS/386 uses a CONFIG.SYS file to define the operating system's environment at boot-up time. Several of the CONFIG.SYS directives are similar to those in PC-DOS. For instance, BUFFERS=nnn tells PC-MOS to set aside nnn (which can range from 1 to 999) 530-byte records in memory for disk buffers. DEVICE=<filename> directs PC-MOS to load <filename> as a device driver.

Other directives, listed below, have no PC-DOS counterparts.

- FREEMEM=*m,n* informs PC-MOS of free memory your system might have between 640K bytes and 1 megabyte; *m* and *n* specify the low and high boundaries, respectively.

- SLICE=nnn sets the time-slice size in units of $\frac{1}{8}$ second. The default is SLICE=1, in which case the processor will service a task for $\frac{1}{8}$ second before swapping in the next task.

- SMP SIZE=nnnK allots nnnK bytes to the system memory pool, which PC-MOS uses to track open files and created tasks. The default is 20K bytes, but as you anticipate running more tasks, you must increase the size.

- USERFILE=<path> \$\$USER.SYS tells PC-MOS/386 where to find the \$\$USER.SYS file, which holds security information.

You can specify a number of other driver files in CONFIG.SYS. For instance, DEVICE=\$CACHE.SYS nnnK installs a disk-caching system. If you include DEVICE=\$EMS.SYS nnnK, then at boot time PC-MOS installs driver code that emulates Lotus-Intel-Microsoft expanded

memory nnnK bytes long. Finally, DEVICE=\$PIPE.SYS <devname>, *n* installs a pipe with buffer size *n* that partitions can use to communicate with one another. Your tasks can access the pipe like any other device with the name <devname>.

And You'll Also Receive . . .

ED is PC-MOS/386's source-file editor, which, fortunately, does not adhere to the format of PC-DOS's Edlin. You can operate ED in one of two modes: a command mode, where you work a line at a time from a prompt line (similar to Edlin), and a visual mode, where ED becomes an easy-to-use screen-oriented editor. I found myself switching to the visual mode constantly, since I could figure out how to make changes with only rare forays to the manual.

DEBUG is the PC-MOS/386 equivalent to the PC-DOS version of DEBUG, with some handy enhancements. Not only does PC-MOS's DEBUG have all the commands of the PC-DOS version, but you can also set up to 10 breakpoints, access the registers of a math coprocessor, and use a remote terminal for your debugging session. Another clever addition is DEBUG's assemble/unassemble command (AU). Using AU when you can enter a machine-code source statement at a selected address, DEBUG will automatically echo your input and display the address and the hexadecimal bytes that the source code translates to.

At the time of this writing, only the user's manual for the operating system was available. Instructions for installation and for setting up various device drivers are clear. Whenever I had trouble with the system, I had no difficulty locating topics in the manual. Sometimes,

continued

Richard Grehan is a technical editor for BYTE. He can be reached at BYTE, One Phoenix Mill Lane, Peterborough, NH 03458.

PC-MOS/386 Modular Operating System version 1.01**Type**

Multitasking, multiuser operating system

Company

The Software Link
3577 Parkway Lane
Atlanta, GA 30092
(404) 448-5465

Format

Two 5¼-inch floppy disks

Computer

80386-based computers with 1 megabyte of RAM and a hard disk drive

Language

Assembly language

Documentation

349-page 8½-by-9-inch ring-bound user's guide

Price

Single-user version: \$195; five-user version: \$595; 25-user version: \$995

though, essential information is missing, as I'll describe later.

I would have liked to have a technical reference manual to experiment with the programming interface. Unfortunately, people at The Software Link said that one wouldn't be available until the early part of August. (One engineer described the programming interface as looking exactly like PC-DOS 3.x with NETBIOS. PC-MOS uses a NETBIOS emulation for task-to-task communications.)

Moving into Multitasking

PC-MOS/386 lets you execute more than one program at once by dividing extended memory (i.e., memory above 1 megabyte) into multiple partitions in which DOS applications execute. The maximum size of any partition is 640K bytes, and the size and number of partitions that you can have depends, of course, on the amount of RAM on your computer. When PC-MOS/386 first boots up, it sets up partition 0 in the memory region below 640K as attached to the main console.

To create a new partition, you use the ADDTASK command. This command lets you specify the partition's size, its task ID, its security class, and a start-up batch file name that's analogous to AUTO-EXEC.BAT in PC-DOS. By specifying these parameters, you create a second

task that is associated with the main console. To access a given partition, you simply press the Alt key and then type that partition's number on the numeric keypad.

To set up a multiuser configuration, you use the ADDTASK command as before, except you specify parameters that indicate the serial port the partition is associated with, the data rate of the port, and the device driver that PC-MOS/386 should use to talk to the remote terminal you're using. (You have your pick of PC-type, ADDS Viewpoint, TeleVideo 910, DEC VT-52, or Teletype terminals, among others.)

Once you've got multiple tasks running, you can call a number of task-maintenance commands. Many of these are grouped under the MOS utility command. They include:

- MAP, which displays a map of all the partitions currently defined, the address at which the partition starts in memory, the size of the partition, the serial port that it's associated with (if any), and more.

- DIS, which lets you disable any code in the current partition that polls the keyboard looking for input (since this could eat up processor time). If PC-MOS senses that a task is awaiting keyboard input, the task is suspended until an actual keyboard request is issued. As I'll discuss later, this may not work for some programs that must have direct access to the keyboard.

- USEIRQ *n*, for reserving control of interrupt vector *n* (where *n* can range from 2 to 7). This handles the situation where two or more tasks attempt to gain control of the same interrupt vector, say, for managing an I/O port. Once a task is completed, it can free whatever interrupts it has control of by using the MOS FREEIRQ *n* command.

Additional commands for managing partition parameters are available in the MOSADM utility command. These include commands for setting the time slice for the task in a partition, assigning a priority to a partition, and turning the system's disk-caching on or off.

Since PC-MOS/386 is a multiuser OS, there's an optional security system that you can install. Basically, it gives you 26 security classes and the ability to assign a class to each directory and file. A user's privileges for a particular directory or file depend on an access-level code associated with that class. This code ranges from 0 to 3 and is read from a user log file (\$\$USER.SYS) and attached to a user when logging onto the system. A 0 access level means the user has no access to a directory or file, a 1 grants execute-only privileges, a 2 grants read and execute

privileges, and a 3 means unrestricted access.

What Works and What Doesn't

I tried a number of popular IBM PC programs with PC-MOS, and the following is a brief description of what I encountered.

- XyWrite III (version 3.05): I loaded a document and did some simple editing. All went well until I tried to quit and received the File open, QUIT anyway? prompt, at which point the machine locked up completely. This is probably a case of an application that sidesteps the operating system and "talks" directly to the keyboard. The PC-MOS user's manual warns of problems with packages like this.

- Norton Commander (version 1.00): When I tried to execute this program, PC-MOS reported that a general software error had occurred and that it was attempting to terminate the application. It succeeded.

- WordStar (version 3.30): This worked fine. I loaded a file, did minor editing, and saved.

- SideKick (version 1.50): When I installed SideKick and attempted to activate it, the machine simply beeped at me four times.

- QuickBASIC (version 2.0): I used the BASIC version of BYTE's Sieve benchmark to test QuickBASIC and had no problem with the compiler.

- Turbo Pascal (version 3.01A): I used a number of the demo programs supplied with Turbo Pascal, and they all worked (including the spreadsheet demo). I also successfully compiled and ran the programs using the version of Turbo Pascal that includes 8087 support. Turbo Pascal's SOUND.PAS demo turned up an interesting effect, however. If I started the program (which causes the computer to sound like a ringing phone) in one partition and switched to another partition, sometimes the sound followed me across partitions. An engineer at The Software Link said that this was due to a program that fools with the system timer, which is a sensitive area to PC-MOS/386 since it uses the timer to generate task-switching interrupts.

- Turbo C (version 1.0): Using Turbo C's interactive environment editor, I recorded the timing routines for the BYTE C benchmarks to use Turbo C's `gettime()` function, recompiled, and executed the programs. I did not run any benchmarks that performed floating-point operations, due to problems with the math coprocessor that I'll discuss later.

- AutoCAD (version 2.6): AutoCAD worked until I attempted to load a drawing, at which time the screen flickered

strangely and I was returned immediately to the system prompt.

•Lotus 1-2-3 (version 2.01): This worked fine in partition 0, but when I created a second task in a 500K-byte partition and switched to the second partition, 1-2-3 simply killed the machine when I executed it. The company said that the version of PC-MOS/386 I was using lets you create a partition that is too big, and that a rule of thumb for maximum partition size was 640K bytes minus whatever size I had set the system-memory pool to. So I reduced the partition size to 400K bytes, and, sure enough, I could run 1-2-3 in both partitions simultaneously.

•Microsoft C (version 4.0): Microsoft C worked fine. However, it was while using this package that I first discovered that PC-MOS/386 and the 80387 didn't get along.

•MetaWare's High C (version 1.3): I really hoped I could execute this package, since it's currently the only C compiler that can generate 80386 code. However, you can run programs created by High C only under Phar Lap's RUN386, and RUN386 will not execute in PC-MOS/386. This is due to the fact that RUN386 attempts to create a protected-mode environment, and since PC-MOS/386 runs programs in virtual 8086 partitions, it won't let RUN386 take control of the 80386. A programmer at The Software Link informed me that the company was working on a fix to allow High C to execute under PC-MOS/386 but did not indicate when the fix would be available.

•GW BASIC (version 2.02): This version of GW BASIC worked like a champ. I used it to run the BASIC benchmarks. It was while running GW BASIC from a remote terminal that I encountered additional problems, however, which I'll discuss below.

Complaints

At the top of my list of gripes is the lack of a list of software that The Software Link has tested on PC-MOS/386. It would be helpful to know what programs you shouldn't even bother trying with this operating system.

I also ran into problems determining the proper setting for environment parameters as defined in the CONFIG.SYS file. Specifically, the manual gives little guidance for choosing a proper time-slice value, and no help at all in picking a proper system-memory-pool size. Your best method for zeroing in on a proper time-slice is experience, and you'll surely want to experiment with different values as the task load changes. However, the only way I could determine a system-memory-pool size that worked was by booting the sys-

tem, trying to add a second task, getting a Not enough memory message, editing the CONFIG.SYS file, rebooting the system, and repeating the process all over again.

I spent most of an afternoon trying to get an external terminal to work with PC-MOS. First I connected a Wyse terminal via a serial cable, but when I initialized a task associated with the serial port, PC-MOS would do nothing but transmit spaces to the monitor. Oddly enough, flow control worked—I could hit Control-S on the Wyse to halt the incoming characters and then use Control-Q, and they'd resume; but I could get no prompt, nor any way to send a command to PC-MOS from the terminal.

Next, I connected an IBM PC and started up the VTERM terminal-emulation program. I finally got things to work and started GW BASIC from the remote terminal. Scrolling was horribly slow, however, since the screen completely re-wrote itself for every new line that rolled in at the bottom. I'm certain that the scrolling was being done by VTERM, so I shouldn't fault PC-MOS for the lack of speed. But during rewriting of the remote terminal's screen, the task running on the main console simply came to a standstill. I could type characters at the console, and the type-ahead buffer would remember them; when scrolling on the terminal was completed, they would burst out onto the screen as the main console task sprang back to life. I contacted The Software Link about this problem and was told that they had not seen it happen before.

Benchmarks

To get a sense of how the operating system performed, I ran the standard BASIC and C benchmarks. The results of the BASIC benchmarks are in table 1. I tried the benchmarks with the time slice set to both 1 and 2 and with a second task (with a partition size of 600K bytes) sitting at the PC-MOS prompt on a remote terminal (i.e., quiescent). The alteration in timeslice size had little or no effect on the execution time. If you compare these results with those obtained running a Compaq Deskpro 386 under Compaq DOS 3.1 (see page 240), you'll see that PC-MOS has little effect on CPU-intensive operations when there's only one active task. Adding a second task added only minor overhead.

PC-MOS/386 runs the Calculation, Sieve, and Read tests as fast as, or only slightly slower than, MS-DOS on a Deskpro 386. However, PC-MOS's Write benchmark is nearly twice as slow. I think this is due to additional code that PC-MOS must run to coordinate multiple tasks accessing the same disk (code that

Table 1: (a) Byte's BASIC benchmarks run in partition 0 with no other partitions activated. (b) The same benchmarks, this time run in partition 0 with another task added (in partition 1) and sitting at the PC-MOS/386 system prompt. All times are in seconds.

a. 1 task in partition 0

	Slice = 1	Slice = 2
Write	10.4	10.4
Read	4.8	4.8
Calculation	7.0	7.0
Sieve	23.4	23.4

b. 2 tasks (1 active, 1 waiting at system prompt)

	Slice = 1	Slice = 2
Write	10.6	10.5
Read	4.9	4.9
Calculation	7.4	7.1
Sieve	24.5	24.0

Table 2: The BYTE C benchmarks run under PC-MOS/386 using Microsoft's C compiler version 4.0.

	No coprocessor	80287
Fibonacci	8.5	8.5
Float	22.7	4.4
Savage	41.7	2.8
Sieve	1.1	1.1
Sort	2.2	2.2
Fileio	128.0	128.0
(with cache)	114.0	113.0
Dhrystone	3125.0	3125.0

(Note: All times are in seconds, except the Dhrystone, which is in Dhrystones per second.)

executes even when you're only running one task).

To test the effects of running multiple tasks, I used the TIME\$ function in GW BASIC. I set up three 500K-byte partitions (in addition to partition 0), executed GW BASIC in each one, and loaded and executed the BASIC benchmark programs with the additional statement

```
50 IF TIME$ <> "13:00:00" GOTO 50
```

tacked on the front of each parameter. In this way, the system executed four copies of each benchmark simultaneously.

The average result for each benchmark

continued

was as follows: Write, 42.5 seconds; Read, 17.5 seconds; Calculation, 28.5 seconds; and Sieve, 97.5 seconds. Except for the Read benchmark, these times are approximately four times greater than the times for the benchmarks run in partition 0 with three additional quiescent partitions. The Read benchmark is only about three times greater. This makes sense: Since all tasks were reading from the same file, the system was most likely performing only one physical read per sector, so three of the four partitions could read the data from memory buffers.

Finally, I executed the standard BYTE C benchmarks. The times you see in table 2 were generated by programs processed by Microsoft C version 4.0. I tested the programs with and without the 80287 math coprocessor, and here's where I ran into another problem. One of our Deskpro 386s has an 80387 installed, and each time I tried executing a C program that made use of the math coprocessor, the machine froze. All these programs worked on the same machine under PC-DOS and executed fine on our other Deskpro 386, which has an 80287. A programmer at The Software Link in-

formed me that the company was aware of this problem and was working on a fix.

A Nice Idea

My most vivid memory of working with PC-MOS/386 is how many times I had to power the machine off and back on again after something I'd done had locked it up. Case in point: The manual clearly documents that the maximum partition size you can create using ADDTASK is "determined by the amount of free memory that is remaining on your computer and cannot be larger than approximately 640K," but I can't remember how many times I executed ADDTASK 600K (and even ADDTASK 500K) on a 4-megabyte machine only to have it lock up—and with only two partitions. The Software Link says it's working on a fix to keep the machine from freezing in such a situation.

Engineers at The Software Link also said they were aware of most of the other problems I had encountered, that they were working on fixes, and that users of PC-MOS/386 would receive free updates for them all. (I was told that the first update was due out in July.)

All in all, although PC-MOS/386 has a

great deal of potential, I cannot at this point recommend it. I wonder whether its multiuser capabilities make any sense in an application beyond, say, a means for a background task to control infrequent access to the system via a modem. And if you're interested only in multitasking, other packages on the market (Quarterdeck's DESQview, for example) provide this capability.

Admittedly, PC-MOS/386 offers an environment for executing protected-mode 80386 programs, and this might prove useful if you're developing 80386 code. But I was unable to use the only high-level 80386 development package that I had—High C—because of PC-MOS's incompatibility with RUN386. Even if The Software Link can get High C to work on this operating system, PC-MOS/386 carries with it the old PC-DOS restriction of a 640K-byte maximum partition size, so there's no way to experiment with larger address spaces.

The idea of a multitasking 80386 operating system with PC-DOS compatibility combined with advanced task communications is exciting. But PC-MOS's designers still have some work to do. ■

Actor 1.0

Leonard Moskowitz

Object-oriented programming languages (OOPL), of which the best-known is Smalltalk, ease program development and maintenance. Often, however, these languages are also slow, memory-hungry, and have a steep learning curve. Actor is an OOPL designed to be a fast, memory-efficient, easy-to-learn alternative to Smalltalk.

Actor version 1.0 (\$495) runs under the Microsoft Windows operating environment version 1.03 on IBM PCs and compatibles with MS-DOS 2.0 or higher. It requires a hard disk drive, a graphics display adapter, a mouse, and 640K bytes of memory. I ran Actor on a 6-MHz IBM PC AT with 640K bytes of memory, an EGA graphics adapter, a 30-megabyte hard disk drive, and a Mouse Systems optical mouse running under PC-DOS 3.2 and Microsoft Windows 1.03.

Actor achieves its speed through use of a token-threaded interpreter, optional early binding, and an incremental dynamic-memory garbage collector, as opposed to Smalltalk's byte-code interpreter, late binding, and various imple-

mentation-dependent garbage-collection schemes. Like Smalltalk, Actor is an interpreted language and provides a rich programming environment.

Actor differs from other object-oriented languages in that its syntax is similar to Pascal and C. Actor allows optional termination with semicolons to make Pascal programmers feel more at home. Assignment is via the := form, which, again, is much like Pascal. Blocks are enclosed in curly brackets, as in C, and the then can be left out of conditional forms. Although these points don't make object-oriented programming concepts any easier to absorb, they do ease the transition.

As with any new release of software, there are a few problems with Actor. A README file on the disk describes most of them and mentions that they will be fixed in the next version. An additional shortcoming is that in the 640K-byte limit of PC-DOS, Actor leaves little room for application code. Future releases of Actor will increase the amount of memory available to a programmer.

[Editor's note: *In the August 1986*

issue of BYTE, dedicated to the theme of object-oriented languages, Charles B. Duff, the author of the Actor language, discusses the philosophy behind its design. Other articles in that issue explain what an object-oriented language is and its advantages and disadvantages over more conventional programming languages, like C or Pascal.]

A Complete Environment

Actor provides a complete programming environment, familiar to the users of Smalltalk and Flavors, including browsers, inspectors, a workspace, and a file editor. Browsers are specialized edit windows designed to view and change Actor-class source code and immediately implement the changes. When you edit in a browser, text is automatically formatted. Inspectors, another kind of window editor, allow you to view an object, send it messages, or modify it. You can use inspectors to trace an object's inheritance of methods and instance variables. The Actor workspace is the developer's primary interaction window. In the workspace, you can write and interpret Actor source code (as you can in the browser and inspector windows), edit, select to browse or inspect, and check on certain system parameters.

Actor provides a solid base of programming code. It comes with more than 90 predefined object classes and hun-

dreds of methods, including various types of windows, collections (arrays, structures, bags, strings, symbols, sets, dictionaries, and graphic objects), associations (for making ordered pairs), characters, and numbers (16-bit signed integers, longs, and reals). One class, Behavior, lets you treat classes as objects and is used to implement inheritance. You can use the browser to explore the class-hierarchy source code for 92 of the classes and their methods. The source for primitive methods is not provided. Primitive methods perform basic operations required by Actor objects, and, in the interest of speed, are written in assembly language.

Two classes, Library and Proc, let you call library procedures from Microsoft languages such as C, FORTRAN, Pascal, and assembly language. You use the Library class to set the filename of the library, and then you add entries for each procedure in the library that you want to use. The Library class creates an instance (or object) of class Proc for each entry, which you can call by sending a pcall message to the Proc object that defines the procedure.

Not all the classes come already loaded into Actor; in some cases, you load them into the environment when you need them. For example, to use the file editor that comes with Actor, you must load in the FileWindow class. If you want the editor to be present each time you enter Actor, you can save a copy (or snapshot) of the environment that you've built up during a session for later use.

When using an editor within Microsoft Windows, such as Microsoft Write, I had to take Actor out of the system because Windows spent most of its time accessing the disk, compensating for the memory shortage. I used WordStar and PC-Write outside of Microsoft Windows, and both worked just fine.

Actor is tightly integrated with Microsoft Windows' mouse-and-menu operating environment, which gives it a familiar feel to those who have used Windows. Windows is slow and ungainly on PCs and XTs, but on an AT, response was timely as long as I was running only Actor and not too close to the memory limit.

Actor provides a full set of interface functions to Windows. You can define windows, menus, dialog boxes, accelerator keys, and icons and pass information between Actor and Windows. Each window becomes an Actor object, and you communicate with it and command it much as you do with any Actor object.

Speed Optimizations

Actor gives you the option of defining the type of a program's variable at compile

(early binding) rather than at run time (late binding). By using this option, you can substantially improve a program's run-time efficiency. As an example, running the Sieve of Eratosthenes with late binding took 6.6 seconds; with early binding, it took 5.4 seconds.

Early binding should be used only after the application is completely debugged and the algorithms are optimized. You can use the class PROF.ACT to profile your application to find which functions the application is spending the most time in. Once you have isolated the heavily used functions, you can specify early binding by explicitly assigning the class of the receiving object so that the compiler can search this class for the object pointer of the method.

[Editor's note: *The source code for both versions of the Sieve test are available on disk, in print, and on BIX. See the insert card following page 256 for details. Listings are also available on BYTEnet. See page 4.*]

In most languages that provide garbage collection, long pauses occur intermittently while the computer reclaims discarded memory. In Actor, however, garbage collection is interleaved with program execution; thus, Actor never stops for a noticeable interval. Actor's object memory is divided into static and dynamic areas. (You can adjust the size of each with parameters in the Microsoft Windows initialization file.) The garbage collector polices the dynamic memory; this memory contains volatile objects, such as strings and integers.

Static memory, which contains objects such as classes, methods, and symbols, rarely changes during run time. But it may fill up during the edit/modify/compile cycle of code development. Then you can explicitly evaluate the cleanup() object to invoke the static-memory garbage collector. The manual cautions that you should save the image of the system first; if Actor runs out of dynamic memory during the static-memory cleanup, you lose all the work done since the last snapshot. I found this out the hard way.

Using Actor

Actor comes on seven 5¼-inch floppy disks. Three hold the Actor files and an installation program, and the other four hold a run-time version of Microsoft Windows. Since I already had a complete version of Windows on my PC AT, I only had to run Actor's installation program. The program transfers the files from the floppy disks to the appropriate directories on your hard disk and adds Actor's static- and dynamic-memory-allocation variables to Windows's initialization file. The process takes under 5 minutes.

Actor 1.0

Type

Object-oriented programming language

Company Name

The Whitewater Group Inc.
Technology Innovation Center
906 University Place
Evanston, Illinois 60201
(312) 491-2370

Format

Seven 5¼-inch floppy disks; not copy-protected

Computer

IBM PC, XT, AT, or compatible with a hard disk drive, at least 640K bytes of RAM, a graphics display adapter, and a mouse

Software Required

MS-DOS 2.0 or higher

Documentation

500-page user's guide with tutorial

Price

\$495 with Microsoft Windows run-time support package; academic price: \$99

The Whitewater Group recommends that memory-resident programs not be used with Actor or Windows and mentions that you may have to delete device drivers and RAM disks to make enough space for Actor. The memory problems were apparent the first time I tried to run Actor: I met with a Not enough memory to run Actor message.

After I deleted all the graphics drivers from my AUTOEXEC.BAT and CONFIG.SYS files, Actor loaded up. I immediately checked to see how much memory was free by using the Microsoft Windows system menu about item (the run-time version supplied with Actor doesn't have this item); only 6K bytes was left. The Actor user's guide says that when less than 10K bytes is available, Actor is running critically short of memory and could crash, so I went back to my CONFIG.SYS and AUTOEXEC.BAT files and deleted the mouse drivers (superfluous under Microsoft Windows). I then had 40K bytes free.

Finally, I deleted my RAM disk driver and 3½-inch floppy disk driver, rendering my extended-memory RAM and the 3½-inch floppy drive useless. This freed up another 12K bytes, making a total of only 52K bytes available. (If I'd been running an IBM EGA board instead of

continued

my Vega video card, roughly another 8K bytes could have been reclaimed, for a total of 60K bytes).

Actor takes up over 350K bytes of memory. Adding Windows's RAM requirement (about 230K bytes in my system) leaves very little for the user. Multitasking under Windows with Actor installed is just about impossible. Even using Windows's spooler causes Windows to access the disk continuously, slowing the work pace to a crawl.

Quirks

Windows considerably eases the task of programming user interfaces, but it has its quirks. It is possible to move a window so that its control areas—size box, caption bar, and system menu—are inaccessible to the mouse. Then you have to remember the keyboard equivalents to the mouse commands to get the window back on the screen. Also, Windows's naming conventions conflict with those of Actor. Method names are lowercase in Actor unless the name is the concatenation of two English words, in which case the first letter of the second word is capitalized. Windows comes with predefined uppercase messages. In addition, Windows limits you to a maximum of five active display contexts at one time.

Actor's user interface is inconsistent. In the workspace window, if you want to execute a section of code, you can position the mouse at the end of the line and press Return. However, if you do this in an editor window (the file editor or the browser), the code is not executed; instead, a new line is inserted. To execute code in the editor or browser, you must select the text with the mouse and click on the DoIt! menu item. There is a hazard to this: Highlighting (inverse video) is used for both editing and execution. If you highlight a section of code to run it via the DoIt! command and then accidentally type some input, the highlighted code is deleted and cannot be retrieved.

There are other inconsistencies: In the workspace, you press Control-Return to insert a new line. In other windows, that does nothing. In some windows, the Control-A accelerator key highlights the entire text; in others, it doesn't. The Select All edit menu item doesn't work at all. Neither does the Undo menu item, which the documentation says will be implemented in a future release.

Cautions

As I mentioned earlier, Actor has a few serious bugs. Once I iconized (i.e., inactivated) a sample window that I'd built during a tutorial exercise. When I reactivated it and tried to close it via the system menu Close item, I received an error

message, and the machine locked up so tight I had to reboot, losing the environment I'd built up during the tutorial.

Another time, I ran the file editor provided with Actor. I selected Actor's parent directory and then its parent, my root directory. When I tried to edit a file, an error window popped up with the message: Dynamic memory is full. When I clicked on its confirmation, Actor exited to Windows and its icon was deleted, and again the environment was lost. This was due to the memory limitations.

On occasion, an error window would pop up claiming that Actor's stack overflowed. If I closed Actor's windows and attempted to reload, Windows would indicate an infinite wait. I could not correct this error, and the only alternative was to reboot. At other times, Actor would lock up for no apparent reason.

There are a few less serious bugs, too, including odd highlighting of areas in the Actor workspace window (the Whitewater Group now has a patch that fixes this), incompatibilities between long and integer objects, and the printing of returned results in inappropriate areas of the workspace. Error messages are printed to the Actor Display window, which is overwritable and not refreshed, so if you have a window overlaying the error message, you will never see it. If you move the window, the text is not restored. This, again, is due to the memory limitations. Other error messages, which are printed in the pop-up window, are truncated and often uninformative. When a file loads, and also when a program runs that prints out to the Actor Display window, other windows' caption lines get replicated over and over again up to the top of the display window. Once the program is loaded or finishes running, the garbage goes away.

Documentation

The Actor user's guide comes in a 500-page three-ring binder. It includes a review of all major classes; sections on memory management, calling external library procedures, accessing MS-DOS and Windows functions, and building applications; a class reference; a language description; a list of error messages; and a complete subcategorized index.

The documentation opens with a quick section on hardware requirements and installation, and then goes through a pleasant and thorough 74-page tutorial. The tutorial includes a short discussion of the Microsoft Windows user interface. Next is a clear description of what object-oriented programming is all about, including descriptions of classes, objects, methods, messages, instances, instance variables, and inheritance. This discus-

sion is highlighted by a short demonstration program implementing a LOGO-like turtle. The tutorial covers the use of inspectors, browsers, some of the primary programming constructs and classes, and it closes with a demonstration of Actor's facility with windows.

On the whole, the documentation is very effective. In some areas, though, it doesn't match the way the programs operate. The file-read method requires an integer argument, but the manual specifies a long-number argument in several places. Methods that the documentation says should return <A Turtle> return their message parameters instead (e.g., the message r(90) returns 90 instead of <A Turtle>).

Also, since Actor is case-sensitive, a user expects the documentation to be reasonably consistent about case. But when you type the message home(Sam), it returns <a Turtle>, which is not quite the same as the documentation's <A Turtle>. Later the manual shows that when you add an element to SortedCollection objects, they return the whole object. In fact, they don't; they return the element.

All in all, however, even with the minor hiccups, the documentation and demonstrations are well written and pleasant to use, and they serve their purpose.

Support

The Whitewater Group provides three levels of support. The first (Level 0) is free access to an Actor bulletin-board service for all registered users, three calls to The Whitewater Group Technical Support Hotline, a promised prompt response to mailed inquiries, and no penalty or charge for bug fixes or reports.

The next two levels of support are \$100 and \$250 options. Level One (\$100) support provides for up to 20 free calls per year to the Hotline, up to a 20 percent discount on future products, free access to a special section on the bulletin-board service, which has maintenance releases and small system enhancements, and interface for one user representative per unit purchased, up to a maximum of three. The Level Two support plan (\$250) provides unlimited phone support from the Technical Support Hotline, access to a developer's workshop on the bulletin-board service, and up to five user representatives. Serious software developers should consider this option. Special support plans are available for academic sites.

Other Considerations

As a development language for the Microsoft Windows operating environ-

ment, Actor has the potential to be a powerhouse, but this potential won't be realized in the cramped quarters of today's 8088/8086/80286-based MS-DOS machines. Actor will come into its own when OS/2 becomes available or when versions of Actor are developed for fast, large-memory-space machines, like the Apple Macintosh II, Commodore Amiga, Atari ST, or 80386-based machines. While it runs acceptably fast on the 80286-based PC AT, it fairly begs for expanded memory. The Whitewater Group says it plans to port Actor to multiple machine architectures and operating

systems and to implement a standard graphics layer. The next release of Windows will provide for expanded memory.

Although Actor 1.0 is expensive, it is also easy to learn and pleasant to use, and it provides strong development and runtime features. Actor's philosophy of appealing to C and Pascal programmers just might lure proceduralists to object-oriented programming. Subsequent releases will probably clean up the minor documentation errors and the software bugs; until then, however, let the user beware. ■

[Editor's note: Actor version 1.1 is now

available and, according to the company, is 60K bytes smaller than version 1.0. The static garbage collector now uses the hard disk as a temporary storage device instead of the dynamic memory region, and the window class hierarchy has been revised.]

Leonard Moskowitz (0-75 Morlot Ave., Fair Lawn, NJ 07410) heads a Research and Development group that applies artificial intelligence technology to the problems of maintenance and diagnostics at Allied Corporation's Bendix Test Systems Division.

ALS Prolog

Alex Lane

The ALS Prolog compiler from Applied Logic Systems is a Prolog language compiler for MS-DOS computers. It is available in two versions, the Professional version 1.0 (\$499) and the Personal version 1.0 (\$199), and requires an IBM PC or compatible with a minimum of 256K bytes of memory and one floppy disk drive. I reviewed both packages on an IBM PC XT with 640K bytes of memory and a 20-megabyte hard disk drive.

Compiling on the Fly

The heart of the ALS Prolog software is ALSPRO.EXE, which reads source files and compiles them on the fly into abstract machine instructions. The package provides object-code files of such instructions for the built-in predicates, a debugger, and a definite-clause-grammar (DCG) expander. The Professional version also provides source code for these predicates.

The Personal version of ALS Prolog comes with a number of examples, including the eight queens problem, the missionaries and cannibals problem, and a symbolic differentiator. The Professional version has a larger number of examples, including a couple of expert programs.

Other software in the ALS package includes VI.EXE, a full-screen text editor from Manx Software Systems that is similar to the Unix vi editor, and ALSKEY.EXE, a memory-resident keyboard-enhancement program.

How ALS Prolog Works

If you've worked with traditional compilers, you might expect ALS Prolog to

generate separate object modules that, when linked, form stand-alone programs independent of the ALS software. However, this is not the case.

The ALS Prolog compiler is an incremental interactive compiler, which means that when you consult Prolog source files, ALS Prolog reads in the consulted files statement-by-statement and compiles them into an intermediate code (as opposed to native 8086 machine language). When compilation is complete, the predicates of the consulted file are represented as a series of instructions for an abstract Prolog machine; these instructions are executed when you run the program. The result is a Prolog implementation that feels like an interpreter yet appears to run much faster than an interpreter, due in part to efficient garbage collection.

A major disadvantage of using intermediate code is that if you plan to sell Prolog applications written with the ALS compiler version 1.0, each of your customers must have a copy of the compiler; the intermediate code won't run without it. Furthermore, there is no way to hide predicates, so the source code for your application is available to anyone with a rudimentary knowledge of Prolog.

ALS automatically saves the abstract object code generated by the compiler in a file with an .OBP extension (unlike the .OBJ extension for object files in other languages) for future loading. If you make no changes to the source file, ALS saves compilation time by directly loading the object file the next time you consult the source file.

A make-like facility that is transparent

ALS Prolog 1.0

Type

Programming language

Company

Applied Logic Systems Inc.
Box 90, University Station
Syracuse, NY 13210
(315) 471-3900

Format

One (Personal version) or two (Professional version) 5¼-inch floppy disks

Computer

IBM PC, XT, AT, or compatible with at least 256K bytes of memory (512K bytes recommended for Personal version) and one floppy disk drive (hard disk drive recommended for Professional version)

Software Required

PC-DOS/MS-DOS 2.0 or higher

Compatible Software

Aztec C86 C compiler, version 3.2

Documentation

ALS Prolog Technical Reference Manual; Prolog Programming for Artificial Intelligence by Ivan Bratko (Reading, MA: Addison-Wesley, 1986)

Price

\$499 (Professional version)
\$199 (Personal version)

to the user decides whether to load existing .OBP instruction files or to read in and compile new source code. Its decision is based on the DOS date-time stamp on the file, so if you are one of those who never enter the correct date and time on

continued

8087 Potpourri

COPROCESSORS

8087 5 MHz	\$99
For the IBM PC, XT and compatibles	
8087-2 8 MHz	\$154
For Wang, AT&T, DeskPro, NEC, Leading Edge	
80287-3 5 MHz	\$159
For the IBM PC AT and 286 compatibles	
80287-6 6 MHz	\$179
For the 8 MHz AT and compatibles	
80287-8 8 MHz	\$259
For the 8 MHz 80286 accelerator cards and Compaq 386	
80287-10 10 MHz	\$395
80387-16 16 MHz	\$495
INTEL INBOARD	\$1250

All MicroWay 8087s include a one year warranty, complete MicroWay Test Program and installation instructions.

64K DRAM 150ns	\$10
256K DRAM 150ns	\$29
PC-PAL Programmer	\$395

287Turbo™ - 10/12

Boost your 80287 speed with 287Turbo and AT speed with 287TurboPlus. 100% software compatible. See our full color ad on page 114 for details.

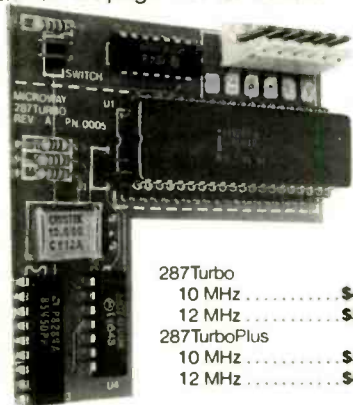

287Turbo	
10 MHz	\$450
12 MHz	\$550
287TurboPlus	
10 MHz	\$549
12 MHz	\$629

PC Magazine "Editor's Choice"

8087 SOFTWARE

MICROSOFT QUICK BASIC	\$79
87BASIC COMPILER PATCH	\$150
87BASIC/INLINE	\$200
87MACRO/DEBUG	\$199
MICROSOFT FORTRAN V4	\$299
RM FORTRAN	\$399
LAHEY FORTRAN F77L	\$477
GRAFMATIC Graphics	\$125
MS or LATTICE C	CALL
STSC APL★PLUS/PC	\$450
STSC STATGRAPHICS	\$675
87SFL Scientific Functions	\$250
87FFT	\$200
OBJ → ASM	\$200
PowerDialer for 1-2-3	\$79
EPSILON EDITOR	\$169

Call for technical information and our complete catalog.

MicroWay P.O. Box 79
Kingston, Mass.
02364 USA
(617) 746-7341

REVIEW: ALS PROLOG

your PC as you boot and reboot your system, beware. It is entirely possible for the ALS program to ignore your most recent changes to a Prolog source file and load old object code that has a "fresher" date.

ALS Syntax

By and large, ALS Prolog implements the standard Prolog syntax found in C-Prolog and Edinburgh Prolog, as published in *Programming in Prolog* by W. F. Clocksin and C. S. Mellish (New York: Springer-Verlag, 1982). ALS's one major extension (besides the use of uninterned atoms, discussed below) is the implementation of modules to support good software-engineering practice. The use of modules lets you isolate some procedures from others by judiciously placing them in separate modules with appropriate use declarations and export declarations.

After working with the software, I concluded that, aside from a few added features, such as an interface to the Aztec C compiler, the Professional version of ALS Prolog is basically the same program as the Personal version. One major difference, however, is that the Professional version supports both interned and uninterned atoms, while the Personal version supports only interned atoms. Thus, in the Professional version, atoms that seldom appear in the program text can be stored on the Prolog heap in memory instead of in the symbol table, thereby conserving valuable space in the table.

Another difference is that the Professional version has predicates that invoke the ROM BIOS services as well as the BIOS keyboard services. This gives programmers an opportunity to write procedures to manipulate the user's screen.

The biggest extra in the Professional package, however, is the ability to utilize the \$icode/4 predicate to access the code generator for the abstract machine instructions. This lets programmers experiment with compilation on the abstract machine or compile "roll-your-own" clauses. The ALS Prolog manual contains several examples of the use of the \$icode/4 predicate, and several more appear in the accompanying source files.

Documentation: Thin but Adequate

The basic ALS package consists of a three-ring IBM-style binder containing printed documentation, one disk of software for the Personal version or two disks for the Professional version, and a card entitling you to a free copy of Ivan Bratko's *Prolog Programming for Artificial Intelligence* (Reading, MA: Addison-Wesley, 1986). [Editor's note: See Alex Lane's review of Ivan Bratko's book in the August issue of BYTE.]

The core section of the ALS documentation is about 60 pages long, and most of those pages are devoted to a terse description of the language syntax and the built-in predicates. Another dozen or so pages discuss the example programs that come with the package. If you consider that ALS intends Ivan Bratko's book to serve as a language tutorial, the documentation is adequate.

The Professional version's documentation contains additional pages that discuss the use of the \$icode/4 predicate, the interface to the Aztec C compiler, and the extra example programs. Both versions include approximately 60 pages of documentation on the VI.EXE editor.

Page 101 of the Professional version manual catalogs a raft of arcane limitations for the package—compiled code is limited to 48K bytes, functors are limited to 15 arguments, the symbol table is limited to 907 entries, and so on. Other limitations were not included in the manual. For example, I learned early on to be leery of floating-point operations in ALS Prolog, such as

```
C is 1.0,
D is C/3.14159,
E is D/28,
F is E*3.14159,
G is F*28,
C := G.
```

This would very likely fail, because the actual value of G is something like 1.0000000000000001, rather than 1.0. However, the debugger would display

```
1 := 1 ?
```

and then calmly announce the failure of the test. This is a problem, because 1 := 1 must be true.

I liked the compact debugger implemented in ALS Prolog. It has the standard trace/1 and spy/1 predicates and a leash/1 predicate, which controls the debugger's prompts at the call, redo, fail, and exit points.

Editor Interface

The ALS package comes set up with the VI.EXE editor, although you can change the default editor using the change_editor/1 predicate. Thereafter, typing

```
edit <filename>
```

suspends operation of the ALS package and lets you use the default editor to edit whatever file you've indicated. If you don't supply a filename, the editor will call up the last file that you edited.

Upon leaving the editor, ALS Prolog "reconsults" the file you are working on;

that is, any predicates in that file overwrite existing predicates in memory. If the system finds any syntax errors while reconsulting the file, it flags them and displays the line number of the error on the screen. As with most compilers, this line number is only approximate. It reflects the line where the error was detected, which is not necessarily where it actually occurred.

Benchmarking ALS Prolog

I performed a series of benchmarks similar to those previously carried out on Borland's Turbo Prolog (see page 295 in the September 1986 BYTE). I did not measure the time required for compilation of code in memory, since this time never exceeded 10 seconds and usually was too short to be noticeable. For the sake of comparison, I also ran the tests on version 1.1 of Turbo Prolog. The results are shown in table 1.

The Math Functions test measures how fast Prolog can calculate the square root, natural logarithm, exponential, arctangent, and sine of a fixed argument 1000 times. The Floating Point test repeats a series of four basic operations 5000 times, while the Sieve extracts the prime numbers between 1 and 100.

The Disk Read and Disk Write tests are Prolog implementations of the standard BYTE benchmarks and measure the time required to perform the respective tasks 512 times on 128-byte atoms.

In my opinion, these benchmarks are of limited value because the power of

Prolog lies not in how fast it can calculate a transcendental function or in how quickly it can isolate primes, but in how rapidly it can manipulate symbols and make inferences. The conclusion to draw from these particular benchmarks is: If

continued

Table 1: Results of the benchmark tests run on the ALS Prolog Compiler and Arity Prolog. Tests were conducted on an IBM PC XT with 640K bytes of memory and a 20-megabyte hard disk drive. All times are in seconds.

Test	ALS Prolog 1.0	Turbo Prolog 1.1
List Reversal	13.79	11.27
Floating Point	201.91	30.83
Sieve	6.7	2.89
Math Functions		
Sqrt	30.81	5.19
Logs	31.25	13.58
Exp	29.0	24.24
Atan	30.21	15.46
Sin	35.05	16.18
Factorial	34.6	21.86
Tower of Hanoi		
5 rings	4.18	2.69
7 rings	19.06	10.87
10 rings	153.13	87.71
Disk Write	29.05	29.73
Disk Read	29.39	15.85



**Nothing Should
Come Between
Mainframe Mag Tapes
and Your dBASE or Lotus
Except**

Telebyte Tape Drives

TDX Mag 9-track 1/2" Tape Systems from Telebyte provide faster, error-free downloading of mainframe data into your PC. You control the start-stop tape drive either from the keyboard or with Telebyte's exclusive Dataverter software for faster file transfer — the equivalent of a 720,000 bit/second datalink.

Telebyte TDX tape drives are available at either 45 or 75 ips, feature dual density (800/1600 bpi) storage and back up processed files at 2 MB/minute (up to 10 times faster than other 9-track drive systems) as a bonus.



Enter data into dBASE® and Lotus® with no user programming. You do it in two easy steps because Telebyte's exclusive **Dataverter runs under both DOS 2.0 and Xenix™**. Dataverter will automatically convert packed, zoned and unsigned decimal field files, as well as labeled tapes, from EBCDIC to ASCII. The tape system is also supported by software languages in your PC, including C, BASIC, Fortran, Cobol, etc.

Only Telebyte offers such mainframe standards of reliability and IBM-compatible tape drive quality for so little money.

TELEBYTE
TECHNOLOGY, INC.

GSA Contract Number GS00K86AGS5301

1-800-835-3298

Telebyte Technology, Inc. • 270 E. Pulaski Road • Greenlawn NY 11740 • (516) 423-3232

dBASE® is a registered trademark of Ashton-Tate, Inc.; Lotus® is a registered trademark of Lotus Development Corporation; IBM® is a registered trademark of International Business Machine Corporation; Xenix™ is a registered trademark of MicroSoft.

you want a language that's suitable for numerical analysis, Prolog isn't it.

Other tests, however, do provide some evidence of the package's performance. These include the Factorial test, which uses simple recursion to measure how fast 10! can be calculated 1000 times; the List Reversal test, which measures the time required to reverse a list of 50 integers 30 times; and, to a lesser extent, the Tower of Hanoi program, which performs recursion and screen output.

I also performed the Peak System Performance and Nondeterministic Behavior benchmarks from the Logic Programming Group and the Computer Architecture Group of the European Industry Research Center in Munich. The Boresea performance benchmark consists of a sequence of 200 predicates having no arguments and no choice points. The results show the effect of pure calls, and the KLIPS (thousands of logical inferences per second) figure gives a rough idea of peak system performance. ALS Prolog ran 1000 iterations of the Boresea test in 5.66 seconds and performed 35.33 KLIPS. The Choice Point benchmark tests calls that invoke the creation of a branch point to which execution may possibly backtrack. The compiler ran 100 it-

erations of this test in 0.37 seconds and performed 5.40 KLIPS.

[Editor's note: *The benchmark programs are included in the file ALS-PRO.TXT, which is available on disk, in print, and on BIX. See the insert card following page 256 for details. Listings are also available on BYTEnet. See page 4. You will need an IBM PC and ALS Prolog or another compatible version of Prolog to run the tests.*]

ALS Prolog Version 1.1

Although the upcoming release of ALS Prolog version 1.1 was not part of the formal review, I did discuss it with Applied Logic Systems. Version 1.1 addresses some of the shortcomings of the current package, and the company said that all owners of version 1.0 will receive a free upgrade to 1.1.

As mentioned earlier, in version 1.0 the size of the compiled code is limited to approximately 48K bytes. According to the company, version 1.1 implements a virtual-memory scheme that will let you write much larger programs. Version 1.1 will also let you create stand-alone .EXE files and allow predicates to be hidden. In addition, an interface to the Microsoft C compiler will be provided.

Finally, the company told me that additional predicates will implement DOS function calls and destructive assignments (along the lines of LISP's RPLACA and RPLACD) to permit creation of Pascal-like data structures.

Nice Product, Some Shortcomings

ALS Prolog is a comfortable, competent package to work with. ALS's conformance to the Edinburgh syntax means that you don't have to master a "new, improved" variation of the language. Compilation is pretty much transparent to the user; if I hadn't been told that ALS Prolog was a compiler, I'd have assumed from the interactive response that it was an interpreter. Two features I particularly liked were the editor interface and the compact debugger.

In general, I liked the ALS Prolog compiler, but I think version 1.0 has too many shortcomings—such as the inability to develop salable applications and the limited clause space of 48K bytes for compiled code—to be worth the price. ■

Alex Lane (Reynolds, Smith and Hills, P.O. Box 4850, Jacksonville, FL 32201) is a senior software engineer and moderator of the Prolog conference on BIX.

12 MHz— NO WAITING!

Introducing the DP12/0 High Performance 100% AT Compatible Motherboard.

True Zero Wait-State design increases throughput up to 30% over competing products.

The DP12/0 design is optimized for demanding engineering and scientific applications... e.g. AutoCAD, Fortran.

- 8/12 MHz Zero Wait-State 80286-12 CPU—Fastest '286 performance available.
- 1 Mbyte CMOS Zero Wait-State RAM.
- 80287 Math Co-Processor socket with independent clock allows full 10 MHz 80287-10 operation.

- ZyMOS POACH/AT CMOS chip set reduces chip count for improved reliability and reduced power consumption.

- 8 expansion slots (6-16, 2-8 bit) with 8 MHz I/O clock to ensure reliable expansion board operation.

- AWARD BIOS with built-in setup utility.

- Quiet, fully socketed, multi-layer board design. 16 MHz ready.

- CMOS Clock Calendar/ Configuration File.

- Keyboard Controller.

- Made in U.S.A.

- One Year Warranty.

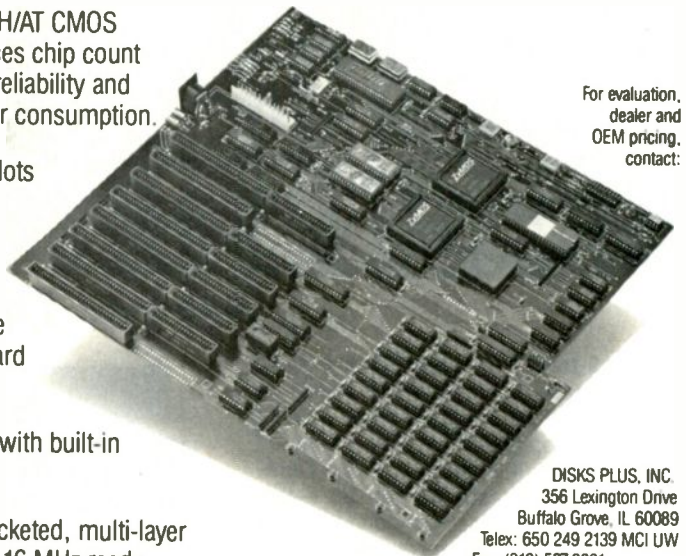

For evaluation, dealer and OEM pricing, contact:

DISKS PLUS, INC.
356 Lexington Drive
Buffalo Grove, IL 60089
Telex: 650 249 2139 MCI UW
Fax: (312) 537-8331

Technical and more info: (312) 537-7888
To order: 1 800 752-DISK

Trademarks: IBM PC-AT, International Business Machines Corp.; AutoCAD, Autodesk, Inc.; Poach/AT, ZyMOS Corporation.

DISKS PLUS
Microcomputers & Peripherals
Also refer to our ad, page 335

Increase your knowledge about all aspects of computers

An absolutely no-risk guarantee.

Select 5 Books for only \$3⁹⁵

More programs, projects, and ways to use your micro.
Keep well-informed about the latest books available—and get discounts of up to 50% off the publishers' prices!



2748 \$21.95



1990 \$24.95

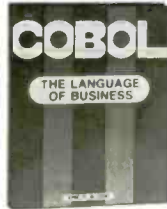

2690 \$24.95



1556P \$15.50



1848P \$15.95



2620 \$25.95



1939P \$17.95



2754 \$28.95
Counts as 2



2627P \$17.95

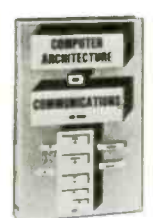

2870 \$24.95



1710P \$15.50



2808 \$27.95
Counts as 2



1643 \$19.95



2702 \$22.95



2855 \$24.95



1874 \$21.95

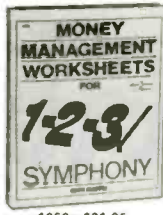

1968 \$21.95



2692 \$27.95
Counts as 2



2850 \$25.95



2680P \$14.95

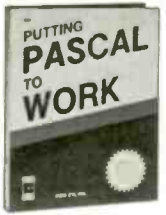

2691 \$23.95



2892P \$16.95

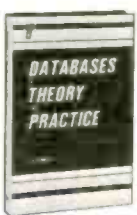

2600 \$28.95
Counts as 2

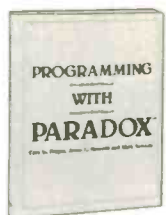

2906P \$19.95



1921P \$15.95



1993 \$21.95



2831 \$22.95



2588 \$26.95
Counts as 2



2749 \$22.95

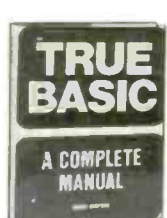

1970 \$22.95



2833 \$21.95



2738 \$29.95
Counts as 2

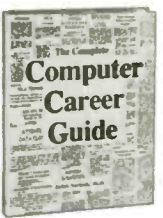

2654 \$18.95



2908P \$19.95



1966 \$26.95
Counts as 2



2757 \$24.95



1894 \$22.95



2771 \$25.95

(Publishers' Prices Shown)

All books are hardcover editions unless numbers are followed by a P for paperback.



The Computer Book Club®

Membership Benefits • Big Savings. In addition to this introductory offer, you keep saving substantially with members' prices of up to 50% off the publishers' prices. • **Bonus Books.** Starting immediately, you will be eligible for our Bonus Book Plan, with savings of up to 80% off publishers' prices. • **Club News Bulletins.** 14 times per year you will receive the Book Club News, describing all the current selections—mains, alternates, extras—plus bonus offers and special sales, with hundreds of titles to choose from. • **Automatic Order.** If you want the Main Selection, do nothing and it will be sent to you automatically. If you prefer another selection, or no book at all, simply indicate your choice on the reply form provided. As a member, you agree to purchase at least 3 books within the next 12 months and may resign at any time thereafter. • **Ironclad No-Risk Guarantee.** If not satisfied with your books, return them within 10 days without obligation! • **Exceptional Quality.** All books are especially selected by our Editorial Board.

If card is missing, use this address to join: THE COMPUTER BOOK CLUB®
P.O. Box 80, Dept. BY-987, Blue Ridge Summit, PA 17214

Inquiry 59

SEPTEMBER 1987 • B Y T E 273



Peter Norton. new programmer who hate

THE NORTON *On-Line Programmer's* GUIDES™

The ultimate productivity tool for programmers. ■ Puts volumes of cross-referenced data at your fingertips. ■ Replaces most manual searches with a few simple keystrokes. ■ Includes compiler for creating your own databases. ■ Also available in versions for BASIC, C and Pascal.



For the complete IBM® PC family and compatibles.

ASSEMBLY

Nobody ever said programming PCs was supposed to be easy.

But does it have to be tedious and time-consuming, too?

Not any more.

Not since the arrival of the remarkable new program on the left.

Which is designed to save you most of the time you're currently spending searching through the books and manuals on the shelf above.

The Norton On-Line Programmer's Guides™ are a quartet of pop-up reference packages that do the same things in four different languages.

Each package consists of two parts: A memory-resident Instant Access™ program. And a comprehensive, cross-referenced database crammed with just about everything you need to know to program in your favorite language.

And when we say everything, we mean everything.

Everything from information about language



Designed for the IBM® PC, PC-AT and DOS compatibles. Available at most software



announces a ng tool for people manual labor.

syntax to a variety of tables, including ASCII characters, line drawing characters, error messages, memory usage maps, important data structures and more.

How much more?

Well, the databases for BASIC, C and Pascal give you detailed listings of all built-in and library functions.

While the Assembly database delivers a complete collection of DOS service calls, interrupts and ROM BIOS routines.

You can, of course, find most of this information in the books and manuals on our shelf.

But Peter Norton—who's written a few books himself—figured you'd rather have it on your screen.

In seconds.

In full-screen or moveable half-screen mode.

Popping up right next to your work. Right where you need it.

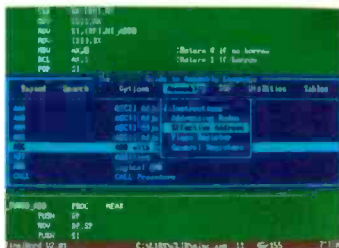

A Guides reference summary screen (shown in blue) pops up on top of the program you're working on (shown in green).

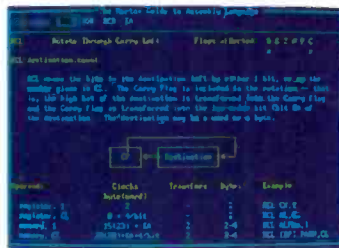

Summary data expands on command into extensive detail. And you can select from a wide variety of information.

This, you're probably thinking, is precisely the kind of thinking that produced the classic Norton Utilities.™

And you're right. But even Peter Norton can't think of everything.

Which is why there's a built-in compiler for

creating databases of your own.

And why all Guides databases are compatible with the Instant Access program in your original package.

So you can add more languages without spending a lot more money.

To get more information, call your dealer. Or call Peter Norton at 1-800-451-0303 Ext. 40.

And ask for some guidance.

Peter Norton
COMPUTING

With
all the
information
out to
clarify
the new
tax law,

this ought to clear things up.

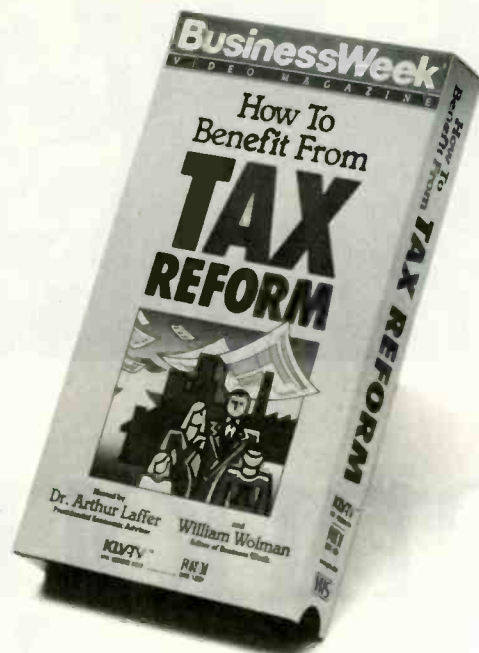

Choose Business Week Video Magazine's "How to Benefit From Tax Reform". Why? That's simple. It's co-hosted by Dr. Arthur Laffer, one of the fathers of tax reform, and an economic advisor to the President. And Business Week Editor William Wolman.

So pull up your chair. And let a panel of America's top tax and investment experts tell you what they know. With candor. Commentaries. Interpretations. The hour will fly by. With clips from the past. Tips for the future.

And most important, what you can do to start benefiting now!

Also included, get the "Business Week Personal Tax Planning Guide"—a comprehensive 48 page guide, prepared by Deloitte, Haskins & Sells—that complements the video. And helps you forecast your own 1987 and 1988 taxes.

Everything you need to know about tax reform. With that same insightful analysis that made Business Week the number one business magazine. The choice is clear. You can get your video somewhere else, but then it wouldn't be from Business Week.

To order now, just call toll-free: **1-800-523-5503** today. (In Illinois, call 1-312-250-9292.)

Or clip and mail in the coupon below.

DISTRIBUTED BY KARL LORIMAR HOME VIDEO IN ASSOCIATION WITH FORUM ENTERTAINMENT.

YES! Rush me *How to Benefit from Tax Reform* and my *Business Week Personal Tax Planning Guide* for only \$29.95 plus \$3.25 shipping & handling (Illinois residents add 7% sales tax).

Check one: Send VHS BETA
 My check (payable to Business Week Video) is enclosed.
 Charge my American Express Visa Mastercard

Acct. # _____

Exp. Date _____

Signature _____

Name (please print) _____

Address _____

City _____

State _____

Zip _____

Clip and Mail Today to: Business Week Video Magazine, PO Box 621, Elk Grove, IL 60009

276 B Y T E • SEPTEMBER 1987

BY-1



Benchmarking dBASE III Plus Compilers

Malcolm C. Rubel

Three packages that have extended features as well as a speed advantage

Quicksilver 1.1 from Wordtech Systems and Clipper (Autumn 1986 version) from Nantucket, two true compilers, and FoxBASE + 2.00 from Fox Software, a pseudocompiler, are all unique implementations of the dBASE III language. Each is a subset of the dBASE III Plus language as defined by Ashton-Tate, and each program has some commands, functions, and capabilities that are not contained in the other packages.

These three compilers are also supersets of dBASE III Plus, because each contains features that are not available in dBASE III. These programs take dBASE III instructions and compile them into more compact code that takes up less memory space and executes faster. Comparing these compilers to dBASE III is therefore a more complex task than simply measuring speed differences. Each program has its own strengths and weaknesses when compared to dBASE III Plus and to each other.

Each of these products supports networking. The network support is included with Clipper and Quicksilver; with FoxBASE +, it costs an additional \$200. Neither Nantucket nor Fox Software will say what local area networks their compilers will run on; they will only say that their compatibility relies on the LAN's proper adherence to using DOS function calls. Wordtech says that Quicksilver will run on the Novell, IBM, and Software 2000 LANs.

All three products support record- and file-locking, exclusive file use, and printer commands. Quicksilver also has an Automatic mode that lets applications run on a LAN without the user's having to go in and do all the programming manually.

Clipper and Quicksilver, the two true compilers, have the ability to integrate unique functions into applications compiled with their libraries. You can write the functions in dBASE, C, or assembly language and then link them to the appli-

cation when the load module is assembled. You can even include these routines in the working .PRG files or develop them as separate object modules. This capability gives both programs a decided edge over dBASE III Plus and FoxBASE +, in that you can develop or purchase custom extensions to the language for a specific purpose and include them as an integral part of the application.

To do this with dBASE III, you must fudge some of these features as a part of a procedure file or purchase one of the add-on packages that will enable you to gain access to the functions. Tom Rettig's Library (which is available in Clipper and dBASE III editions) and the dBASE Tools for C package enable you to perform this type of function, but both require you to use more programs and more memory. If you intend to distribute your final application, this also adds more files and more cost for the end user.

One negative aspect of both Clipper and Quicksilver is that neither permits access to the dBASE III Plus full-screen functions, including APPEND, BROWSE, CHANGE, and EDIT. This means that you must spend time programming replacements for these functions if you need them. This is not as great a loss as it would seem, however, as commercial-quality applications should not be using these functions anyway because they permit unrestricted access to the database without any edit checks.

Clipper

Nantucket's Clipper, the first of the native-code dBASE compilers, was released over two years ago and has undergone four major revisions. The current release, which is simply called the Autumn 1986 version, includes network

support, some new commands, and a better memory-management capability that includes support for expanded memory. Nantucket says that Clipper-compiled programs can use up to 1 megabyte of RAM for indexing, although I did not test this. In certain situations with large indexes, this should substantially improve the product's indexing speed.

Of the three compilers, Clipper is probably the least compatible with dBASE III Plus. Several commands, including box commands, READKEY, and Return to Master, are either not supported by Clipper or are supported in a different manner than that of dBASE III Plus. Clipper also has many commands and functions that are not available in dBASE III Plus. These include special help capabilities, memory variables, the ability to open multiple parent-child relationships at once, special menu-creation commands, the SAVE SCREEN command, arrays, FOR...NEXT loops, and the VALID function, to name a few.

The differences between Clipper and dBASE III can make Clipper more versatile than dBASE III, but they also make programming more difficult, as most people would use dBASE III for program development and then compile their applications with Clipper. Nantucket supports a CLIPPER public variable that enables developers to include Clipper-specific code in their development files that does not run when the file is executed on an interpreter such as dBASE III Plus. Unfortunately, as soon as you start including some of the more powerful Clipper commands, you must start writing

continued

Malcolm C. Rubel is president of Performance Dynamics Associates (305 Madison Ave., New York, NY 10165), a consulting firm specializing in office systems, and author of Programming the dBASE III Plus User Interface (Bantam Books, 1987).

	Clipper (Autumn 1986 version)	Quicksilver 1.1	FoxBASE + 2.00
Type	dBASE compiler	dBASE compiler	dBASE pseudocompiler
Company	Nantucket Inc. 12555 Jefferson Blvd. Los Angeles, CA 90066 (213) 390-7923	Wordtech Systems Inc. P.O. Box 1747 Orinda, CA 94563 (415) 254-0900	Fox Software Inc. 27493 Holiday Lane Perrysburg, OH 43551 (419) 874-0162
Format	Three 5¼-inch floppy disks	Eight 5¼-inch floppy disks	Two 5¼-inch floppy disks
Computer	IBM PC or compatible with at least 256K bytes of RAM to compile programs, two floppy disk drives (hard disk drive recommended), and DOS 2.0 or higher	IBM PC and most other MS-DOS computers with at least 256K bytes of RAM, two floppy disk drives (hard disk drive recommended), and DOS 3.1 or higher	IBM PC or compatible with at least 360K bytes of RAM, two floppy disk drives (hard disk drive recommended), and DOS 2.0 or higher
Language	C	C	C
Documentation	User's manual, 200 pages	User's manual, 452 pages	User's manual, 350 pages
Price	\$695	\$599	Single-user version: \$395 Multiuser version: \$595 Single-user run-time: (10/unlimited) \$300 / \$500 Multiuser run-time: (10/unlimited) \$500 / \$700

code solely for Clipper, because the code differences between Clipper and dBASE III quickly become a burden.

Clipper also supports many of dBASE III's functions in a slightly different manner than dBASE III does, so you must learn a slightly different language if you want to compile your applications with Clipper. For example, the Clipper VALID function as a part of the PICTURE template language provides a way for you to program direct access to HELP, lookup tables, or to other programs during the middle of a READ; dBASE III does not support this feature. To use the feature, you must learn how to program this function for Clipper, as well as how to write code that will execute under dBASE III during program development.

While there is a tremendous amount of information in the Clipper user's manual, it is sometimes not easy to find what you need (even with the index), and then you must read the information carefully. Nantucket should do some work to make the manual a more usable document. The manual is split into two different sections: the basic manual and the Autumn 1986 update. For a compiler that costs close to \$700, it is not too much to expect a better-quality manual.

Clipper comes with a custom version of Phoenix Computer Products' Plink86, so you can compile applications that are too large to fit into RAM as overlay programs. Unless you need to use the overlay capabilities of Plink86, however, the

DOS LINK program supplied with MS-DOS works just as well and is quicker. I used DOS LINK as a linker for Clipper for all the benchmark tests.

Unless specifically told otherwise, Clipper compiles the named program and all called programs into a single object file. You can then link that object file or files with the Clipper library to create an executable load module. Clipper lets you compile separate specified object modules using a special compiler file with a .CLP extension. Clipper will then compile only those files you specify. This feature can be used for reducing compile times during debugging and for creating overlays.

By press time, Nantucket had not yet released its Spring 1987 version of Clipper. I called the company, however, and received a description of the latest version's new features and enhancements. Nantucket says it has improved Clipper's indexing speed due to recoding and compatibility. Clipper indexes can be either Clipper- or dBASE-compatible. The compiler's sorting speed has also been improved due to recoding.

The Spring 1987 version of Clipper also has a number of new commands. The SET SOFTSEEK ON/OFF command allows "relative" seeking (i.e., if a record is not found, the pointer is set at the next logical record). The SET CURSOR command turns the cursor on or off, SET MESSAGE TO <expN> [CENTER] centers a message on the specified line, and the

MEMOLINE and MLCOUNT functions can format a memo for printing. In addition to these functions, the latest version of Clipper has a number of file-handling functions that are compatible with DOS 3.3. The program now provides for more than 150 open files and can handle strings up to 64K bytes long.

Quicksilver 1.1

Wordtech Systems advertises Quicksilver 1.1 as the first dBASE III Plus compiler. The compiler supports the dBASE III Plus language more closely than Clipper does, but if you use the full capabilities of Quicksilver, it is not compatible with dBASE III either. Although version 1.1 of Quicksilver is more compatible with dBASE III Plus than the original version was, it also implements some commands that take it further away from dBASE III Plus.

Quicksilver 1.1 supports FOR...NEXT loops and has an excellent help function that is part of the @GET command. A set of AUTOMEM functions provides a mechanism for creating, loading, and clearing memory variables with the same names as field variables, as well as replacing data-table fields with the contents of these memory variables.

Several of Quicksilver's functions bring it much closer to the extended capabilities of Clipper. The SET ORDER TO function enables you to have more than one index active at a time, FROW() and FCOL() position the cursor in an alternate

the product now runs faster than version 1.21 in all areas that I tested by an average of 23 percent. The program is memory-sensitive; I ran out of room running large indexes with under 480K bytes of free memory. This should not have happened, but at least Fox Software is up-front about this and will tell you that the program likes a lot of memory.

FoxBASE + has several capabilities, commands, and functions that look and act very much like Clipper's. The compiler also has some excellent dBASE III language extensions of its own. It sup-

ports UDFs and has a VALID function for data verification. UDFs can now be added as part of the VALID argument. The program handles arrays (with each element a separate MEMVAR that counts as part of the maximum number of variables), multiple children open to one parent file, and the ability to create bounce-bar menus, pop-up boxes, and save-and-restore screens.

FoxBASE + automatically converts dBASE III code to FoxBASE + code when you DO a program. You have the option of compiling code beforehand, which

speeds up program loading but not execution. You can also assemble up to 180 programs into a single procedure file with the FOXBIND utility before compilation. This way, you end up with a single .FOX file that you can execute using FoxBASE + or the optional FoxBASE runtime module.

FoxBASE +'s indexing is faster than dBASE III's, and its indexes are smaller. They are not dBASE-compatible, however. The index files in version 2.00 are a bit larger than those in version 1.21, but they are still smaller than those in dBASE III, Clipper, or Quicksilver.

Table 1: Execution benchmark results (from a 31K-byte test) for Clipper, Quicksilver, and FoxBASE +. Times for the dBASE III compiler are provided for comparison. The first set of results given for Quicksilver, .DBC, is for the d-code overlay program; the second set, Native, is for the speed-optimized native code. All times are in seconds.

Test	dBASE III	Clipper	Quicksilver (.DBC)	Quicksilver (Native)	FoxBASE +
SCREEN1	58	34	47	28	8
SCREEN2	97	125	62	33	13
SCREEN3	196	50	85	46	19
APPEND	36	207	137	142	14
CALC1	188	29	100	55	19
CALC2	59	5	17	9	4
CALC3	144	8	33	16	8
CALC4	32	51	22	17	6
CALC5	1000	135	237	132	70
LOCATE1	39	36	63	54	14
LOCATE2	26	25	52	41	13

Execution Benchmarks

One of the main reasons to compile dBASE III code is to make the code execute faster. Surprisingly, when subjected to a series of benchmark tests, both of the true compilers showed significant weaknesses when compared to dBASE III Plus in their ability to move speedily through a data table. Both compilers were fast on calculations, but they were slow when doing anything with an unindexed file. Both of the true compilers were also slow in the indexing benchmarks, averaging about 75 percent of the speed of dBASE III Plus.

Because Quicksilver 1.1 gives you the option of two different types of executable code, I've supplied two separate times for this compiler for each benchmark test. The first time given, .DBC, is

REVIEW: DESQVIEW 2.00

DESQview 2.00

Type

Concurrent, multitasking, windowing environment

Company

Quarterdeck Office Systems
150 Pico Blvd.
Santa Monica, CA 90405
(213) 392-9701

Format

One 5¼-inch floppy disk

Computer

IBM PC, XT, AT, or compatible, IBM PS/2 computer, or Compaq Deskpro 386 with 512K bytes of memory (640K bytes recommended), two floppy disk drives or one floppy disk drive and one hard disk drive, and a monochrome, CGA, EGA, VGA, or Hercules display adapter; mouse recommended

Software Required

PC-DOS or MS-DOS 2.0 or higher

Language

Assembly language

Options

Quarterdeck Expanded Memory Manager 386: \$59.95

Documentation

210-page user's guide; 14-page version 2.00 upgrade booklet

Price

\$129.95

contains more colorful graphics, more troubleshooting information, and a new guide to error messages. A section entitled "Programmer's Reference" explains how to interface programs with DESQview. Version 2.00 has 12 options that aid in custom-installing programs, and its help screens are context-sensitive.

Installation

During the normal installation procedure for hard disk operation, DESQview searches for programs it recognizes, such as Lotus 1-2-3 or Multiplan, and, at your option, it can automatically install its custom DESQview Program Information File (DVP) setup for these programs. This file contains information about the program it describes, such as the DOS command that starts it up, how much memory it needs, and the drive and directory that it is stored on. DESQview can also use IBM TopView Program Information Files (PIFs).

Installing a program that has a PIF file merely requires that you name the program and tell DESQview what directory it is located in. The rest of the setup information is included in that file. You can easily modify window characteristics (such as size, colors, and so forth) either permanently during setup or temporarily while in a window.

You can custom-install programs that don't come with a PIF file by specifying a set of parameters, such as how much memory the program will require, whether it uses graphics, whether it can be swapped to disk, whether it requires a key disk, and what key letters you want to use when calling it up.

Auto-dial settings and modem characteristics, as well as long-distance access codes, are also set during initial setup, as is the proportion of time spent in foreground and background processing and which, if any, mouse you will be using. If you have an earlier version of DESQview installed in your system, the custom installation features are retained when you upgrade to version 2.00.

Running Programs

WordStar, WordPerfect, and Lotus 1-2-3 run fine under DESQview and will even run in small windows because they have automatic custom installation available in DESQview's setup. Copy-protected programs requiring start-up disks are easier to operate using DESQview, because once they are started, you can switch to a program in another window and back again without having to shut down the copy-protected program and insert the key disk to start it up again.

Because DESQview enables you to window most nonresident programs, and

because DESQview provides its own macro key facility, your need for many memory-resident programs is greatly reduced. DESQview supports version 1.5 of SideKick, which should be started in its own window but will operate in all windows. Print spoolers and RAM disks should be loaded before DESQview.

While DESQview will operate in a system with only 512K bytes of memory, if you want to do multitasking you will quickly run out of memory when loading programs in different windows on a 512K-byte system. For instance, a copy of KnowledgeMan/2 will practically fill 640K bytes, and, if you want to run Lotus 1-2-3, DESQview will have to swap KnowledgeMan/2 to disk; if your system has only floppy disk drives, you will have a long wait, and even swapping to a hard disk takes about 15 seconds.

Using DESQview with EMS memory gives your programs more room, but, because you can't run programs completely in EMS memory, there is a limit to how much it can help. EMS memory provides a 64K-byte window onto a memory space above the 1-megabyte limit of DOS. Programs such as Lotus 1-2-3 Release 2.0, which are designed to use EMS memory for data storage, make use of the EMS memory regardless of the amount of memory assigned in the program setup (as long as enough regular memory is allocated to load the program). For programs that are not designed to specifically take advantage of EMS memory, you can use this memory as a RAM disk.

DESQview operates best when EEMS memory is available because, unlike EMS memory, you can run a larger part of programs from it. When using EEMS boards, you will want to remove or disable as much of your system memory as possible, setting the EEMS board to replace up to 640K bytes. DESQview uses EEMS memory as "shadow" memory (i.e., DOS doesn't know it exists) below the 640K-byte DOS limit. By having only 128K bytes of motherboard memory and the remainder derived from the EEMS board, DESQview can allocate 636K bytes to the first window you open and more than 600K bytes to each additional window until you run out of memory.

Only users who have large amounts of EEMS memory available in their systems will be able to take full advantage of DESQview 2.00's capabilities. Without EEMS memory, you have to spend a lot of time waiting for programs to be swapped on and off a disk or RAM disk when the regular memory is not sufficient to accommodate all the resident software. If you have about 5 megabytes of EEMS memory available, this completely eliminates the need for disk swap-

I installed and ran DESQview on two different machines. One was a 10-megahertz PS/2 Model 60 with 1 megabyte of RAM, one 1.44K-byte 3½-inch floppy disk drive, a 40-megabyte hard disk drive, parallel and serial ports, and a mouse. The other computer I used was a 4.77-MHz Tandy 1200 with a 10-megabyte hard disk drive, 640K bytes of memory, and an AST SixPakPremium Enhanced Expanded Memory Specification (EEMS) board with 2 megabytes of memory.

A big advantage for some users is that version 2.00 of DESQview enables you to run DOS programs, such as Format and Copy, in the background. The documentation for version 2.00 is nearly twice as long as that of older versions, and it also

ping, even if nine windows are open, since each window has nearly 640K bytes available to it, and any MS-DOS program will run in that amount of memory.

Background Processing

In addition to loading multiple programs simultaneously, DESQview will allow programs to continue to run in the background. The more time devoted to these background programs (such as a spreadsheet recalculation, for instance), the slower the foreground screen becomes. For tasks such as word processing, data entry, or other relatively slow operations, you can allocate a lot of time to the background, and the machine will not appear to run slowly. Allocating little time to the background will enhance the performance of the foreground program.

When running DESQview on the IBM PS/2 Model 60 with a fast (33-millisecond access time) hard disk drive, I found that it was practical to run several programs, even in a machine that did not have EEMS memory. Disk swapping was so much faster that it took an average of only 1.95 seconds to swap large programs. Even with 1 megabyte of standard memory, however, it was difficult to open more than 11 windows before run-

ning out of common memory.

Even if you are limited to only 640K bytes of regular memory, some programs that require only 60K bytes to run in a window, such as WordStar 3.31, let you load multiple copies with ease and switch between projects or files with two keystrokes and no wait for disk swapping.

For 80386 machines, the Quarterdeck Expanded Memory Manager 386 (\$59.95) is available as an option. It allows you to take advantage of the 80386 extended memory. DESQview also supports the virtual 80386 architecture on the Deskpro 386. The installation procedure is slightly different, but otherwise DESQview works as it does with other computers, using up to 5.5 megabytes of memory to run programs in windows as big as 624K bytes each. Version 2.00 supports virtual screens on 80386-based computers and takes advantage of the EGA screen's larger text capacity.

One ideal use of a multitasking system would be to run a communications program in the background for uploading or downloading while you work on something else in the foreground. When installing a communications program, you must be sure that it is never swapped to disk while operating. One communica-

tions program that I have found to work well in the background is HyperACCESS from Hilgraeve Inc.

What's It Good For?

I found DESQview to be particularly handy for use with copy-protected programs that require a key disk. I found it practical to always keep a copy of Lotus 1-2-3 running in one window because it is so easy to access when I don't have to deal with copy protection every time I want to reload it during a workday.

DESQview is suitable for users who need multitasking and can afford to slightly increase processing time for each program, or for users who need to switch between a number of programs quickly and often. If you run programs concurrently, however, they will all slow down (considerably, if your computer is running at 4.77 MHz). If you stick to programs that have PIF setup information or programs for which DESQview has a special setup, then DESQview will operate with no problems, and installation will be very simple. ■

John McCormick (RD #1, Box 99, Mahaffey, PA 15757) is a computer consultant and freelance writer.

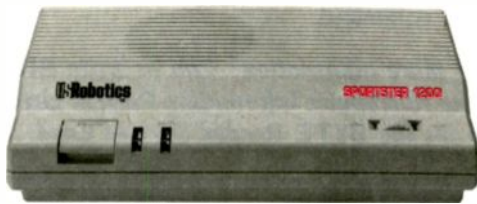

Computer communications made simple, made affordable. And made in America.

A new line of modems from \$139. At prices this low, you might expect a modem to come from across the ocean. But the beautifully compact Sportster 1200™ comes from USRobotics, a leading American manufacturer for over 10 years.



A Sportster internal or external modem teamed with your computer connects you to a world of information at 1200 or 2400 bps. Choose from three models.

\$139 to \$299. Easily the USA's best modem value.

1-800-DIAL-USR Ext. 29
In Illinois, call 312-982-5001



The Sportster features auto-dial, auto-redial and auto-answer. And it uses the industry standard AT command set, so it works with all data communication software.

For quick reference, the bottom panel contains a printed operations summary. You also get a 28-page user's guide, a two-year warranty, USR's Telpac™ Communications Software for IBM users, and a free subscription and connect time to the CompuServe® information service.

Call us today for your nearest dealer.

USRobotics™

The Intelligent Choice In Data Communications

BIX Microbytes: One of

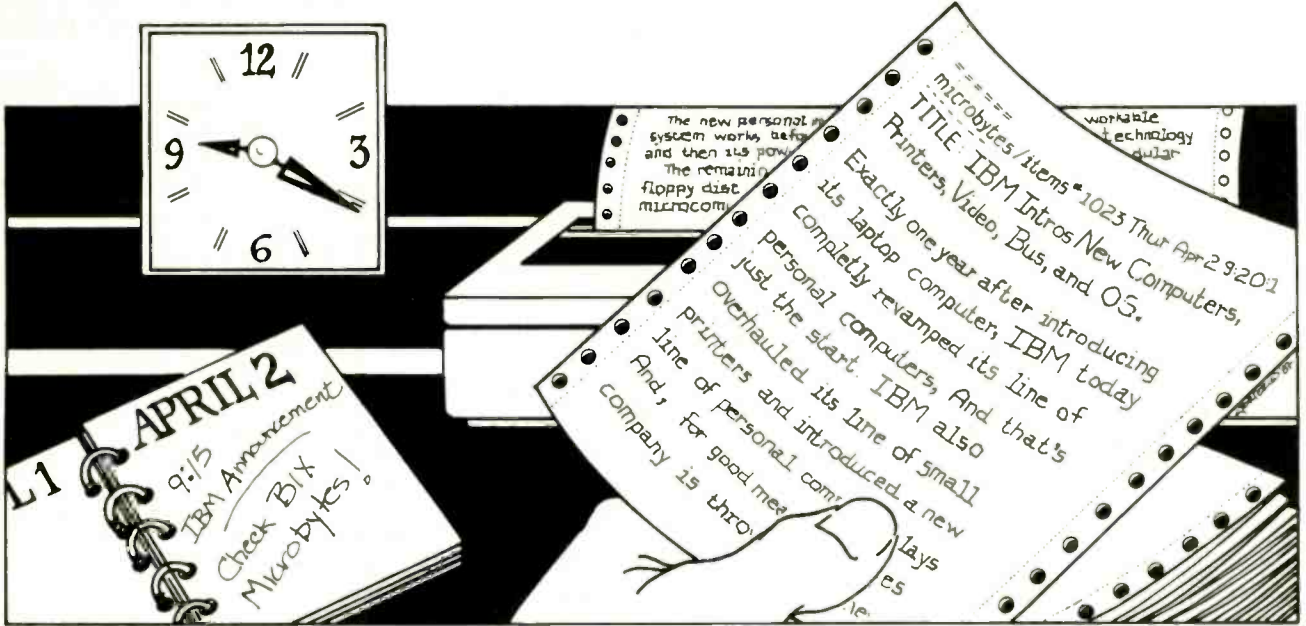

Timely and Detailed Computer-Related News and New Product Information Via Your Computer

—IBM unveils its new Personal System/2 Computers and OS/2 operating system. BIX begins providing detailed coverage to its 17,000 users worldwide, five minutes after the corporate unveiling.

—A spokesman for a major 386 chip manufacturer says the industry is turning to single-sourcing. BIX has the story and analysis, including a forecast of possible 386 chip shortages in the months ahead.

—Buyers of a major computer manufacturer's newest product report interface problems with some hard disk drives. BIX reports first on the problem and on the company's announcement of an update.

If information like this vital to you and to your company, you should know about Microbytes, one of six powerful services you get when you join BIX.

NEWS

Microbytes is a daily newswire of computer-related information, available to all BIX users. BYTE and BIX editors attend trade shows and press conferences, talk with industry leaders, researchers and product developers and scan thousands of press releases. Each day they file detailed reports, often exclusive, filled with information that's vital to you—new technologies and trends that will influence the products of the future, major speeches and events, acquisitions and more.

NEW PRODUCTS

Microbytes is new product information. BYTE and BIX staff analyze thousands of new computer-related products each month, and detail the most significant in specially organized hardware and software product listings.

DETAILED AND IN-DEPTH

Microbytes supplements BYTE's editorial coverage with additional articles, interviews and special product previews and reviews. You never miss important items because BIX remembers what you've read and takes you immediately to any new information posted since the last time you were on. And since important news is retained on-line, you can quickly locate past coverage of specific products or events using the powerful BIX search command.

Need more information? Call or write BIX and ask for the Microbytes Information Pack or circle number 425 on the BYTE Reader Service Card.

Join Microbytes Today

If you're unfamiliar with on-line services but interested in Microbytes, we've made things easy for you. Follow the procedures on the opposite page, but enter the word **micronews** in place of the word **new**. You'll be automatically joined to the free BIX learn conference (which teaches you how to use the system) and to Microbytes. (Other BIX services are yours whenever you want them. Once you've registered, BIX bills you only for the time you are connected...no minimum monthly charges or special fees.)

BIX Microbytes is one of six powerful services available to you when you join BIX.

Six great reasons to join **BIX** today

- **Over 140 microcomputer-related conferences:**

Join only those subjects that interest you and change selections at any time. Take part when it's convenient for you. Share information, opinions and ideas in focused discussions with other BIX users who share your interests. Easy commands and conference digests help you quickly locate important information.

- **Monthly conference specials:**

BIX specials connect you with invited experts in leading-edge topics—the IBM PS/2 family, OS/2, and more. They're all part of your BIX membership.

- **Microbytes daily:**

Get up-to-the-minute industry news and new product information by joining Microbytes.

- **Public domain software:**

Yours for the downloading, including programs from BYTE articles and a growing library of PD listings.

- **Electronic mail:**

Exchange private messages with BYTE editors and authors and other BIX users.

- **Vendor support:**

A growing number of microcomputer manufacturers use BIX to answer your questions about their products and how to use them for peak performance.

What BIX Costs. . How You Pay

ONE-TIME REGISTRATION FEE: \$25

Hourly Charges: (Your Time of Access)	Off-Peak 7PM-6AM Weekdays Plus Weekdays & Holidays	Peak 6AM-7PM Weekdays
--	--	-----------------------------

BIX	\$9	\$12
Tymnet*	\$2	\$8
TOTAL	\$11/hr.	\$20/hr.**

* Continental U.S. BIX is accessible via Tymnet from throughout the U.S. at charges much less than regular long distance. Call the BIX helpline number listed below for the Tymnet number near you or Tymnet at 1-800-336-0149

** User is billed for time on system (i.e., 1/2 Hr. Off-Peak w/Tymnet = \$5.50 charge.)

BIX and Tymnet charges billed by Visa or Mastercard. Call or write for other billing options.

BIX HELPLINE

(8:30 AM-11:00 PM Eastern Weekdays)

U.S. (except NH) and Canada—1-800-227-BYTE
Elsewhere (603) 924-7681

Inquiry 450



We'll
Send
You a

BIX User's Manual and Subscriber Agreement
as Soon as We've Processed Your Registration.
JOIN THE EXCITING WORLD
OF BIX TODAY!

JOIN BIX RIGHT NOW:

Set your computer's telecommunications program for full duplex, 8-bit characters, no parity, 1 stop bit OR 7-bit characters, even parity, 1 stop using 300 or 1200 baud.

Call your local Tymnet* number and respond as follows:

Tymnet Prompt

Garble or "terminal identifier"
login:
BIX Logo—Name:

You Enter

a
bix <CR>
new <CR>

After you register on-line, you're immediately taken to the BIX learn conference and can start using the system right away.

FOREIGN ACCESS:

To access BIX from foreign countries, you must have a packet switching account with your local Postal Telephone & Telegraph (PTT) company. From your PTT enter 310600157878. Then enter bix <CR> and new <CR> at the prompts. Call or write us for PTT contact information.

BIX

ONE PHOENIX MILL LANE
PETERBOROUGH, NH 03458
(603) 924-9281

News about the Microsoft Language Family

Microsoft® Macro Assembler Version 5.0

Microsoft Macro Assembler Version 5.0 has a host of exciting new features that make assembly language programming easier and more powerful than ever! Microsoft Macro Assembler Version 5.0 now includes the Microsoft CodeView® window-oriented debugger and can assemble instructions written for the Intel® 80386 CPU. Comprehensive documentation and example programs help you write assembly code subroutines that can be called from other Microsoft languages such as C, BASIC, FORTRAN, and Pascal. Microsoft Macro Assembler Version 5.0 also assembles your programs 25 - 40% faster than Version 4.0.

Now it's easy to write assembly language subroutines for high-level language programs

If you have always wanted to write fast assembly language subroutines to make your programs fly, now is the time to try Microsoft Macro Assembler Version 5.0. Version 5.0 comes with a completely new Mixed-Language Programming Guide, which describes in clear, step-by-step language how to write, assemble, and link an assembly language subroutine with your Microsoft BASIC, C, FORTRAN, or Pascal programs. The examples from this manual are provided on disk so you can use them as templates, filling in your own code and leaving the prologue and epilogue instructions that make the interface function correctly.

Now Microsoft Macro Assembler Version 5.0 makes segmentation easy. Our new "simplified segmentation" directives are short, straightforward, and intuitive: To declare the correct model for your subroutine, just use the .MODEL directive and choose the model you need: SMALL, MEDIUM, COMPACT, LARGE, or HUGE. To start your data segment, just add a .DATA directive; to set your stack, add a .STACK



Microsoft Macro Assembler's CodeView at Work.

directive; and to begin writing instructions, use the .CODE directive.

Microsoft Macro Assembler now includes the CodeView source-level debugger

CodeView, Microsoft's famous debugger for its C and FORTRAN languages, now comes to the world of assembly language programming. Source-level debugging

allows you to view your program just as you wrote it, including the comments and spacing that are especially important in helping you follow your program's execution. You can access variables by name, even if they aren't declared public, and see constants as names instead of as anonymous numbers.

Write programs for the 80386

Microsoft Macro Assembler Version 5.0 can assemble the new instructions available with the powerful 80386 CPU and the 80387 math coprocessor, as well as 80286 instructions that have been enhanced to work with 32-bit registers. You can also use the new 32-bit wide registers to write faster programs than ever by using such operations as 32-bit add and subtract and 32-bit multiply and divide without using multiple registers. For more powerful data access Microsoft Macro Assembler Version 5.0 allows you to choose any 32-bit register for indirect memory access, to use "scaling" for easy array access, and to move 32 bits of data directly from memory into a register and back.

For more information on the products and features discussed in the Newsletter, write to: Microsoft Languages Newsletter, 16011 NE

36th Way, Box 97017,
Redmond, WA 98073-9717.
Or phone: (800) 426-9400.
In Washington State and
Alaska, call (206) 882-8088.
In Canada, call (416)
673-7638.

Latest DOS Versions:

Microsoft C Compiler	4.00
Microsoft COBOL	2.20
Microsoft FORTRAN	4.01
Microsoft Macro Assembler	5.00
Microsoft Pascal	3.32
Microsoft QuickBASIC	3.00

Microsoft, the Microsoft logo and CodeView are registered trademarks of Microsoft Corporation. Intel is a registered trademark of Intel Corporation.

Kernel

**Computing at Chaos Manor:
In the Chips** 289
by Jerry Pournelle

**Applications Only:
Potpourri** 307
by Ezra Shapiro



CONNECT.



OCR SCANNING

Our "SCANNING CONNECTION" system can be used to read your paper documents into a PC. Pictures and graphs can be scanned and saved in various file formats for use by many word processing and desktop publishing systems. Text images can be converted to character text for use with most word processing and typesetting systems. Images can be sent over telephone lines to another PC or a facsimile machine.

We have developed a special controller card for high speed compression of images and for character recognition. Books, magazines, newsprint, reports and typed documents can be read by our OCR software. The software can be trained to recognize almost any font style. System prices including scanner and software start at \$1795.

9-TRACK TAPE

With our "TAPE CONNECTION" system you can read and write most 1/2" 9-Track magnetic tapes using your PC. Tapes can be 800, 1600, or 6250. Our file transfer software can process ANSI labeled tapes from most computer systems including DEC, HP, HONEYWELL, and IBM. Large files from multivolume tape reels can be transferred to a disk at rates up to 5 MB/min. Software is provided to use the system for backup of the hard disk on your PC.

With more than twenty years experience in working with tape drive systems, we can solve most PC tape conversion problems. We can supply more than ten different tape drive models. System prices including tape drive, controller card, and software start at \$3495.

DISKETTE CONVERSION

We specialize in conversion systems and can transport your documents or images to almost any computer, word processing, or typesetting system. With our "DISKETTE CONNECTION" system you can read and write most 8", 5 1/4", or 3 1/2" diskettes using your PC. We support systems from DEC, CPT, WANG, NBI, LANIER, HONEYWELL, and XEROX. We support most IBM systems including 3741, S/36, PC/36, 4300, and Displaywriter.

Since 1981 we have developed hundreds of software programs and designed many specialized diskette hardware products. With thousands of installations worldwide, we are probably the world leader in manufacturing diskette conversion systems. System prices including diskette drive, controller card, and software start at \$1195.



Inquiry 95 for End-Users.

Inquiry 96 for DEALERS ONLY.

1120 Kaibab • Flagstaff, AZ 86001 • 602-779-3341

Compusol-Europe • 12 Rue Rosenwald • 75015 Paris • Tel 530.07.37 • Telex 205431F



In the Chips

Jerry Pournelle

Fast Kat gets even faster with a math coprocessor, DESQview, and VOPT.

It was almost a quiet month. Of course, we did have to go to Atlanta for Spring COMDEX. Then there were publicity arrangements for *Janissaries III: Storms of Victory* and the new Niven/Pournelle/Barnes book *Legacy of Heorot*, and Niven and I have been hard at work on *The Moat Around Murcheson's Eye*, and we got a new puppy and had to persuade the cat not to leave home; but all in all, nearly quiet.

Fast Kat

It's official: the main machine at Chaos Manor is now Fast Kat. For the record, Fast Kat is a Kaypro 386 with built-in EGA color. Mine has accessories: the Intecolor Megatrend 19-inch EGA monitor, a DataDesk Turbo-101 keyboard, Xerox PC TypeRight in-line spelling checker box, and Amdek CD-ROM reader. They work together fine, and the system is *fast*. While I was changing over from *Zelda the Zenith Z-248* to Fast Kat, I did some rearranging. My desk is now completely surrounded by computers. One of these days I'm going to design some computer furniture; nothing I've seen makes really efficient use of the limited space near a desk.

Otherwise, I don't have a lot to report about Fast Kat that I didn't say last month. Once in a while I think I've found PC-compatible software Fast Kat won't run, but every time that has turned out to be my fault.

We did make one improvement since last month; we managed to install a math chip. It wasn't easy.

Math Chips

Last month's column featured a new round of tests with my matrix benchmark program. Examining the results gave me a surprise: no matter what the basic speed of the machine, for math-intensive programs like matrix operations, the really dominant factor is the presence of a math chip. There are differences between the 8087, 80287, and 80387, but they are

nothing compared to the difference between having a math chip and not having one.

Fast Kat didn't come with a math chip, but once I started playing with benchmarks, it became obvious he'd need one.

Intel makes a small adapter board about 3 inches square to adapt the 80287 math chip so that it can work with an 80386 CPU. The Intel people were kind enough to send me several of them for the various machines we have here. First to get one was the CompuAdd Standard 286-II with the Cheetah Adapter/386 board.

On opening the machine I found a minor problem: Cheetah makes its own adapter to accept an 80287. The solution was to pry the 287 from the Intel adapter. I'd heard the 287 doesn't have to run at the same speed as the 386 chip, and this seemed a good time to test it. We dropped the 6-megahertz 287 into the adapter in the Cheetah. It worked fine. For the past couple of weeks, Dave Moore has been using this as the development machine for fixing up FTL Modula-2, so the system has been getting a heavy workout; no problems.

After that, it was Fast Kat's turn. Since Intel makes the Kaypro 386's motherboard as well as the 287 chips and adapters I had, this should have been a snap, but it wasn't. Because of the geometry of the hard disk and power supply installations on the Kaypro 386, you physically cannot install the standard Intel 287 adapter.

A quick call to the Kaypro technical-support people established that Kaypro has a special version of the adapter board, and that they'd send me one. In a couple of days there appeared a box that was prominently marked Intel Singapore

Limited. The label said it was a "Single Board Computer," but actually it contained an adapter board with circuitry identical to the standard 287 adapter, but laid out differently; basically, all the components were rotated

90 degrees.

Now it'll be easy, I thought. The little chip assembly goes next to the power supply and under the hard disk cage; it looked like a tight fit, but I thought that would only be a matter of moving things.

Hah. It was no trouble to remove the front clips holding the hard disk and slide the disk forward; but then I found that the hard disk's cage doesn't come out. The bottom support of that cage is a piece of steel bent at a right angle; it's bent down far enough that it was impossible to slide the chip board under the disk cage. It was clear that if I could ever get the adapter board inserted into its socket I'd have plenty of room; but while the pins on the square gate-array socket are considerably more rugged than those on a standard chip, I didn't want to force things.

Eventually I took the vise grips to the cage-support bar; by bending that angle bracket so that it's about 60 degrees instead of 90 degrees, I haven't weakened it much (as all Kaypro stuff is, it's strong enough to resist 7.5 on the Richter scale); and that made just enough room to slide the assembly under the cage. I'd previously lubricated the pins with Stabilant (what I used to call Tweek), and it dropped right in.

After that, things went fast. Reassembly was no trouble, and everything works fine. A few days later, while talking to the Kaypro technicians about setup software, I mentioned the problem I'd had getting the math chip in.

"Gee," one said. "We didn't think you

continued

Jerry Pournelle holds a doctorate in psychology and is a science fiction writer who also earns a comfortable living writing about computers present and future.

could do that. We always take out the motherboard."

Sigh.

DESQview Yet Again

Yesterday morning, I got a beta-test developer's copy of Softguard's VM/386 virtual operating system for the 386. I haven't had a chance to do anything with it; at least it exists.

For the moment, though, the best way to get much of the power of the 386 is with Quarterdeck's DESQview. For those who've missed the past few

months' discussions, DESQview is a program that allows multitasking. In a 286 AT system, DESQview does this by swapping programs in and out of extended memory or, if need be, to disk or RAM disk files. It can do that on a 386, too, but, in fact, Quarterdeck's QEMM 386 Memory Manager program coupled with the 386's speed makes all that pretty well invisible.

DESQview isn't perfect. Far from it. It has DESQview Utilities consisting of a calculator, calendar, dialer, and notepad, and while they're all right, they're not as

easy or convenient (at least for me) to use as SideKick is. For example, I like to use SideKick to grab stuff from the BIX screen, edit and modify it, and then squirt it back to BIX through the modem. With SideKick, the importation is almost trivially easy. The export is tougher: first you do Control-K E, then tell it what key to trigger the squirt, then mark the beginning and end of the block to be squirted. I have a SuperKey macro that makes all that a great deal simpler.

For a while my SideKick upload procedure didn't work, and I thought it was something to do with the 386; but it turned out I'd copied my AUTOEXEC.BAT file wrong and invoked SideKick before SuperKey. SideKick has to be last, and if it isn't, not only can you mess up SideKick's ability to export stuff with the Control-K E command, but you can muck up other programs as well.

As an example, I've set up Brief, my favorite programming editor, in its own directory and put a path to that directory in the AUTOEXEC.BAT file. This works fine, unless you put SuperKey after SideKick. When you do that, if you call Brief from anything but its own subdirectory, the machine locks up. The first time that happened I thought it was Brief's fault, but it wasn't.

The moral of the story is that if you use memory-resident programs and get odd results from anything else, you'll probably want to check the memory residents before spending a lot of time in diagnostics.

Provided that SideKick is installed last, though, it really is convenient.

Alas, SideKick won't work with DESQview. If you invoke SideKick in its own window, DESQview won't let it have a communications port; if you invoke it in a batch file in the same DESQview window as, say, Crosstalk, your communications are going to be slow and jerky. I don't know why, but the effect is very real—and even if you were willing to put up with that, the SideKick export won't work anyway!

All of which means that if you use DESQview, you have to put up with the DESQview Mark, Cut, and Paste routine, which is awkward. The DESQview notepad editor uses mostly the same commands as WordStar, and they can be changed if you like, so it's not hard to use. But unless you invoke the DESQview notepad before you start any other job, the colors are so grimly horrible you can't believe them. In theory, it's easy to change colors in a DESQview window. In practice, it's one more thing to try to learn, and the colors for the notepad would *still* depend on when you opened

continued



Z80
68020 C
8051

RISE

to the finest **CROSS DEVELOPMENT** Software Available

- ▶ Does your cross compiler or assembler have limitations?
- ▶ Does it run out of symbols?
- ▶ Does it have trouble with large functions or files?
- ▶ Rise above those limitations and select a product that offers you **NO** limitations:

68020 + 68881 C Cross Compiler:
Powerful one-pass optimizing compiler that easily compiles functions and files of any size. Strong type-checking and excellent diagnostics help you meet your deadlines.

from \$995

Z80, 8051, 680X0 Macro Assemblers:
Extra long symbol names, unlimited number of symbols and powerful macro facilities are just some of the features you'll receive, and these are just a few of the chips we support; call for others!

from \$295

UniWare is a *complete*, fully-integrated package offering you a powerful linker, librarian, and many utilities.

Available **NOW** under MS-DOS, XENIX and UNIX

We are so confident of UniWare's capabilities that we will let you use UniWare *on your job without risk* for 30 days. You must be satisfied. If not, return it for a full refund.

Call Today.
(312) 971-8170

Developed and Supported by:
Software Development Systems, Inc.
3110 Woodcreek Drive
Downers Grove, Illinois 60515
USA

UniWare is a trademark of Software Development Systems, Inc.
MS-DOS and XENIX are trademarks of Microsoft Corporation
UNIX is a registered trademark of AT&T Bell Labs

THE PROGRAMMER'S SHOP

helps save time, money and cut frustrations. Compare, evaluate, and find products.

RECENT DISCOVERY

RTC PLUS by Cobalt Blue. Translate FORTRAN 77 and RATFOR to C except F77 I/O, FORTRAN character, and complex expressions. Some DEC F77 extensions. Library C Source. MS \$ 279

AI-Expert System Dev't

Arity Combination Package PC \$ 979
 System - use with C MS \$ 229
 SQL Dev't Package MS \$ 229
 Auto-Intelligence PC \$ 739
 CxPERT - shell for C MS \$ 295
 Experteach - Powerful, samples PC \$ 339
 Exsys PC \$ 309
 Runtime System PC \$ 469
 Insight 2+ MS \$ 379
 Intelligence/Compiler PC \$ 739
 T.I.: PC Easy PC \$ 435
 Personal Consultant Plus PC \$2589
 Personal Consultant Runtime PC \$ 85
 Turbo Expert-Startup(400 rules) PC \$ 129
 Corporate (4000 rules) PC \$ 359

AI-Lisp

Microsoft MuLisp 85 MS \$ 159
 PC Scheme LISP - by TI PC \$ 85
 Star Sapphire MS \$ 459
 TransLISP - learn fast MS \$ 79
 TransLISP PLUS
 Optional Unlimited Runtime \$ 139
 PLUS for MSDOS \$ 169
 Others: IQ LISP (\$239), IQC LISP (\$269)

AI-Prolog

APT - Active Prolog Tutor - build applications interactively PC \$ 49
 ARITY Prolog - full, 4 Meg
 Interpreter - debug, C, ASM PC \$ 229
 COMPILER/Interpreter-EXE PC \$ 569
 Standard Prolog MS \$ 77
 MacProlog Complete MAC \$ 269
 MicroProlog - Prof. Entry Level MS \$ 85
 MicroProlog Prof. Comp./Interp. MS \$ 439
 MPROLOG P550 PC \$ 175
 Prolog-86 - Learn Fast MS \$ 89
 Prolog-86 Plus - Develop MS \$ 199
 TURBO PROLOG by Borland PC \$ 69

Basic

BAS_C - economy MS \$ 179
 BAS_PAS - economy MS \$ 135
 Basic Development System PC \$ 105
 Basic Development Tools PC \$ 89
 Basic Windows by Syscom PC \$ 95
 BetterBASIC PC \$ 129
 Exim Toolkit - full PC \$ 45
 Finally - by Komputerwerks PC \$ 85
 Mach 2 by MicroHelp PC \$ 55
 QBase - by Crescent Software MS \$ 89
 QuickBASIC PC \$ 69
 Quick Pak-by Crescent Software PC \$ 59
 Stay-Res PC \$ 59
 Turbo BASIC - by Borland PC \$ 69

FEATURE

TP2C - Translate Turbo Pascal to formatted K & R C (proposed ANSI 85 standard). Include files, in-line code, nested procedures. 95 + % successful conversion. PC \$ 219

Free Literature Compare Products

Evaluate products. Compare competitors. Learn about new alternatives. One free call brings information on just about any programming need. Ask for any "Packet" or Addon Packet. C AI. ADA. Modula. BASIC. C. COBOL. Editors. FORTH. FORTRAN. PASCAL. UNIX. PC or Debuggers, Linkers.

Our Services:

- Programmer's Referral List
- Compare Products
- Help find a Publisher
- Evaluation Literature FREE
- BBS - 7 PM to 7 AM 617-740-2611
- Dealers Inquire
- Newsletter
- Rush Order
- Over 700 products
- National Accounts Center

C Language-Compilers

AZTEC C86 - Commercial PC \$499
 C86 PLUS - by CI MS \$359
 Datalight C - fast compile, good code, 4 models, Lattice compatible, Lib source, Dev's Kit PC \$ 77
 Datalight Optimum - C MS \$ 99
 with Light Tools by Blaise PC \$168
 Lattice C - from Lattice MS \$269
 Let's C Combo Pack PC \$ 99
 Let's C PC \$ 59
 Microsoft C 4.0- Codeview MS \$275
 Rex - C/86 by Systems & Software - standalone ROM MS \$695
 Turbo C by Borland PC \$ 69
 Uniware 68000/10/20 Cross Compiler MS Call

C Libraries-Files

C Index by Trio/PLUS MS \$319
 BTree by Soft Focus MS \$ 69
 CBTREE - Source, no royalties MS \$ 99
 CTree by Faircom - no royalties MS \$315
 rtree - report generation PC \$239
 dbQUERY - ad hoc, SQL-based MS \$129
 dbVISTA - pointers, network.
 Object only - MSC, LAT, C86 \$129
 Source - Single user MS \$389
 dBx - translator to library MS \$299

C-Screens, Windows, Graphics

C-Scape - capture Dan Bricklin PC \$179
 Curses by Aspen Scientific PC \$109
 dBASE Graphics for C PC \$ 69
 ESSENTIAL GRAPHICS - fast PC \$185
 GraphiC - new color version PC \$285
 Greenleaf Data Windows PC \$159
 w/source PC \$289
 Light WINDOWS/C-for Datalight CPC \$ 79
 Windows for C - fast PC \$189
 Windows for Data - validation PC \$319
 Vitamin C - screen I/O PC \$159
 View Manager - by Blaise PC \$179
 ZView - screen generator MS \$139

Atari ST & Amiga

We carry full lines of Manx & Lattice.

Call for a catalog, literature and solid value

800-421-8006

THE PROGRAMMER'S SHOP™
 Your complete source for software, services and answers

5-B Pond Park Road, Hingham, MA 02043
 Mass: 800-442-8070 or 617-740-2510

7/87

RECENT DISCOVERY

dB2C Toolkit V 2.0 by Software Connection. 220+ dBIII functions in C source, file handler, windowing, interface to db_VISTA, c-tree, dBC III, MS, Lattice, Instant C. No Royalties MS \$ 289

dBASE Language

Clipper compiler PC Call
 dBASE II MS \$329
 dBase III Plus PC \$429
 dBASE III LANPack PC \$649
 DBXL Interpreter by Word Tech PC \$139
 FoxBASE+ - single user MS \$349
 Quick Silver by Word Tech PC \$439

dBASE Support

dBase Tools for C PC \$ 65
 dBrief with Brief PC Call
 DBC ISAM by Lattice MS Call
 dFlow - flowchart, xref MS Call
 Documentor - dFlow superset MS Call
 Genifer by Bytel-code generator MS \$299
 QuickCode III Plus MS \$239
 Tom Rettig's Library PC \$ 89
 UI Programmer - user interfaces PC \$249

Fortran & Supporting

50:More FORTRAN PC \$ 95
 Forlib+ by Alpha MS \$ 59
 I/O Pro - screen development PC \$129
 MS Fortran - 4.0, full '77 MS \$279
 No Limit - Fortran Scientific PC \$109
 PC-Fortran Tools - xref, pprint PC \$165
 RM/Fortran MS Call
 Scientific Subroutines - Matrix MS \$129

Multilanguage Support

BTRIEVE ISAM MS \$185
 BTRIEVE/N-multiuser MS \$455
 Flash-Up Windows PC \$ 79
 GSS Graphics Dev't Toolkit PC \$375
 HALO Development Package MS \$389
 HALO Graphics PS \$209
 Infomnix 4GL-application builder PC \$789
 Infomnix SQL - ANSI standard PC \$639
 NET-TOOLS - NET-BIOS PC \$129
 Opt Tech Sort - sort, merge MS \$ 99
 PANEL MS \$215
 Pfinish - by Phoenix MS \$229
 Polyboost - speed I/O, keyboard PC \$ 69
 Prime Factor FFT - 8087/287 PC \$145
 PVCS Corporate-source control MS \$309
 PVCS Personal MS \$109
 QMake by Quilt co. MS \$ 79
 Report Option - for Xtrieve MS \$109
 Screen Machine PC \$ 59
 Screen Sculptor PC \$ 95
 SRMS - new version MS \$159
 Synergy - create user interfaces MS \$375
 VXM - multi-env. link MS \$195
 Xtrieve - organize database MS \$199
 ZAP Communications - VT 100 PC \$ 89

FEATURE

C Worthy Interface Library - Complete, tested human interface for MS C, Lattice or Turbo C. Full screens, Windows, DOS, Error handling, Menus, Messages. Source separate, no royalties. PC \$249

Note: All prices subject to change without notice. Mention this ad. Some prices are specials. Ask about COD and P.O. Formats: 3 laptop now available, plus 200 others. UPS surface shipping add \$3 item.

Subscription Problems?

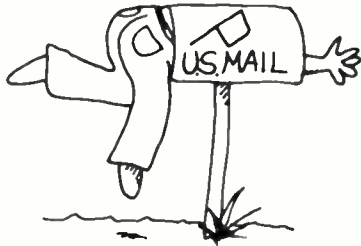

We want to help!

If you have a problem with your BYTE subscription, write us with the details. We'll do our best to set it right. But we must have the name, address, and zip of the subscription (new and old address, if it's a change of address). If the problem involves a payment, be sure to include copies of the credit card statement, or front and back of cancelled checks. Include a "business hours" phone number if possible.

BYTE
Subscriber Service
P.O. Box 6821
Piscataway, NJ 08854

its window. Unlike the SideKick editor, there's no way to set colors for the notepad itself.

Then, too, if I invoke the notepad first (and thus get the screen colors The Norton Utilities set for me on boot-up), odd things can happen. At least once I brought Fast Kat up in DESQview, opened the notepad as one window, opened Crosstalk as another, and connected to BIX. I used the Mark, Cut, and Paste routines to do some editing. All worked fine. Then I closed the Crosstalk window and went to bed, leaving the DESQview notepad as the sole surviving job.

The next morning the machine was locked up. I had to reset to get started.

That could, of course, be the result of a mini power failure or some kind of hardware glitch. I'd be more inclined to think so if similar things hadn't happened under DESQview, and not when DESQview was turned off. Of course, most of my problems have been due to insufficient spelunking of the DESQview manual; but some, I think, were just plain bugs.

For all that, I tend to use DESQview more and more. For one thing, Quarterdeck is quite responsive to bug reports; the DESQview you'll be able to buy when you read this will not be the same one I'm running. Also, DESQview has some really neat features, including a very nice keyboard swap and macro program similar to SuperKey. It's possible to build a customized file of keyboard macros that will be "automagically" invoked whenever you bring in the program they're associated with.

For example, when I bring in WordPerfect under DESQview, I also bring in a macro that redefines the backspace to "left-arrow delete left-arrow right-arrow." The "left-arrow delete" business is necessary because DESQview won't let you define a key recursively; and the "left-arrow right-arrow" monkey motion makes WordPerfect reformat the paragraph. I expect that would be a silly thing to do on a slower machine, but on the Kaypro 386, the operation is instantaneous.

The macros are neat, but mostly, DESQview is still the only way to do real multitasking; and that's quite often worth the problems DESQview can cause.

Swaps

I use DESQview a lot, but not always; often, it's just more convenient to have my usual bunch of memory-resident programs. Of course, I want them installed automatically; I also tend to want a different configuration of memory residents

continued

New! Code View? For Turbo Pascal?

T-DebugPLUS 2.0 brings powerful but easy-to-use symbolic run-time debugging to your fingertips -- the same power you'd expect to find in Microsoft's CodeView™. Debug Turbo Pascal programs faster with:

- ◆ Watch windows for variables
- ◆ Conditional breakpoints
- ◆ CGA, EGA & Hercules graphics



EDITOR'S
CHOICE

"T-DebugPLUS is the most important Pascal tool ...since Turbo itself."

PC Magazine, June 23, 1987



T-DebugPLUS is only \$60.

Call toll free for credit card orders.

1-800-538-8157 x 830

1-800-672-3470 x 830 in CA

Satisfaction Guaranteed or your money back within 30 days.

Also from TurboPower Software: Turbo OPTIMIZER, makes your compiled programs smaller and faster, only \$75.
Turbo EXTENDER, breaks the 64K barrier, only \$85.
TurboPower Utilities, only \$95 with source.

For other information call 408-438-8608, 9AM to 5PM PST. Shipping & taxes prepaid for US and Canadian customers, others please add \$6 per item. CodeView is a trademark of Microsoft Corporation. ©TurboPower Software, 1987

TurboPower Software 3109 Scotts Valley Dr., Suite 122 Scotts Valley, CA 95066

THE PROGRAMMER'S SHOP

Offers a 31 Day Money Back Guarantee on any product in this ad. Call Today.

NEW! From Sterling Castle... BASIC Development Tools™

Powerful "Automatic Programming" Tools
That Save You Hours of Valuable Time.

The novice or power programmer, can easily add these professional features.

- Screen Builder
- B+ Tree
- EZ Screen Pop-up Windows
- Help Message System



BASIC Development Tools™ (BDT™) is compatible with the newest, fastest compilers, including Microsoft QuickBASIC™ and Borland Turbo Basic™. In BDT you have four powerful aids that can be used separately or together.

Screen Builder System translates the painted screen image into BASIC code which then can be merged in your program.

B+Tree Data Manager is a very fast data file index system providing both direct and sequential access to data. Complete source provided.

EZ Screen Pop-up Window Manager, written in assembler, easily inserts menus, windows, notepads. Saves a portion of the screen to/from a buffer.

Help Message System allows the creation of context sensitive help messages in your application program.

With BDT you have four of the most popular programming aids for \$99. Includes two diskettes and 220 page manual.

60 DAY FREE TRIAL.
ORDER TODAY! (800) 722-7853
(213) 306-3020 in California

STERLING CASTLE™

Sterling Castle 712 Washington St. Suite 174
Marina del Rey, CA 90292

Inquiry 336

All trademarks are acknowledged.

#1 PROGRAMMABLE
EDITOR

VEDIT PLUS

FREE fully functional DEMO disk!

Stunning speed. Unmatched performance. Total flexibility. Simple and intuitive operation. The newest VEDIT PLUS defies comparison.

Other editors just don't offer this wide a range of features:

- 'Off the cuff' macros
- Built-in macros
- Keystroke macros
- Multiple file editing
- Windows
- Macro execution window
- Trace & Breakpoint macros
- Execute DOS commands
- Configurable keyboard layout
- 'Cut and paste' buffers
- Undo line changes
- Paragraph justification
- On-line calculator

VEDIT PLUS performed 10 times faster than its nearest competitor in a pattern matching search test and replaced patterns even faster.

Go ahead. Call for your free, fully functional demo today. You'll see why VEDIT PLUS has been the #1 choice of programmers, writers, and engineers since 1980.

Available for IBM PC's, MS-DOS, and CP/M.

Inquiry 337

List: \$185
Ours: \$125

CompuView

1955 Pauline Blvd., Ann Arbor, MI 48103 (313) 996-1299. TELEX 701821

PVCS *The Most Powerful & Flexible Source Code Revision & Version Control System*

The POLYTRON Version Control System (PVCS) allows programmers, project managers, librarians and system administrators to effectively control the proliferation of revisions and versions of source code in software systems and products. PVCS is a superb tool for programmers and programming teams. (A special LAN version is also available.) If you allow simultaneous changes to a module PVCS can merge the changes into a single new revision. If the changes conflict, the user is notified. Powerful capabilities include: Stores and retrieves multiple revisions of text; Maintains a complete history of revisions to act as an "audit trail" to monitor the evolution of a software system; Maintains separate lines of development or "branching"; Provides for levels of security to assure system integrity; Uses an intelligent "difference detection" to minimize the amount of disk space required to store a new version. Requires DOS 2.0 or higher. Compatible with the IBM PC, XT, AT and other MS-DOS PCs.

Sug. Retail Prog. Shop

Personal PVCS		
—For single-programmer projects	\$149	\$109
Corporate PVCS		
—For larger, multiple-programmer projects	\$395	\$309

Call POLYTRON at (503) 645-1150 for pricing on larger networks

POLYTRON
High Quality Software Since 1982

Call Today for FREE detailed information or try RISK-FREE for 31 days

800-421-8006

HOURS: 8:30 A.M.-8:00 P.M. E.S.T.

5 Pond Park Road, Hingham, MA 02043 Mass: 800-442-8070 or 617-740-2510 5/87

Inquiry 338

FREE*: Probe the Minds of 19 World-Class Programmers!

Programmers at Work is a fascinating collection of interviews with industry leaders like Jon Sachs, Wayne Ratliff, Dan Bricklin, and Bill Gates. "Prefaced by a short biography and including program doodles and samples of source code, each interview examines the forces, the events, and the personality traits that have influenced the programmers' work."

FREE* or Only \$14.95!

— from the jacket

NOW: Special OFFER!

via coupon (or mention this ad)

* Order any product on this page OR \$250 of any software and get **Programmers at Work FREE!**

Payment method: Check/MO MasterCard/VISA

Acct. # _____ Exp.: _____

Your Computer: _____ O/S: _____

Name: _____

Street: _____

City: _____

State: _____ Zip: _____

Item: _____ Price: _____

UPS Ground \$3/item, Air \$6/item. (except book):

(Call about other methods)

Total: _____

Offer expires 9/30/87.

The Programmer's Shop, 5 Pond Park Rd., Hingham, MA
02043-(800) 421-8006 or in MA (617) 740-2510

B

Inquiry 339

Even More Power & Flexibility

BRIEF 2.0

BRIEF easily conforms to your editing preferences and style, ensuring you are truly comfortable and productive.

Straight from the box, BRIEF is as much editor as most people will ever need — thanks to features like the real Undo, flexible windowing, and unlimited file size.

But BRIEF's hidden power is in its exclusive macro language. Customize BRIEF to include the commands and features YOU desire. It's fast and easy.

Users and industry press alike unanimously praise BRIEF. "Recommended." — Jerry Pournelle, Byte 12/86.



Now BRIEF 2.0 adds:

- Basic Features**
- Setup Program for easy installation and configuration. (Requires no macro knowledge).
 - Increased speed for sophisticated operations like Undo and Regular Expression Search.
 - All new documentation WITH tutorial on the Macro Language.
 - Command line editing (move cursor, add & delete characters, specify parameters).
 - Expanded Regular Expressions, with matching over line boundaries.
 - More block types, with marking by character, line or column.
 - Reconfigurable indenting for C files (supports most indenting styles).
 - Enhanced large display support, including wider displays.
 - Optional borderless windows.

Try BRIEF (\$195) for 30 days — if not satisfied get a full refund.
If you already own BRIEF, call for update info.

CALL 800-821-2492

In MA 617-337-6963

Solution Systems

541 Main Street, Suite 410B
So. Weymouth, MA 02190

And much, much more!

Requires an IBM PC, AT or compatible with 192K.

CHAOS MANOR

depending on which job I want to do. That used to take me more time than I like.

The solution to that seems obvious enough now, but I confess it took me a while to think of it. What I've done is make a series of batch files that copy specialized versions of AUTOEXEC.BAT and CONFIG.SYS. As an example, I have a file called MAKEREG.BAT that says

```
Echo off
Echo Setting up to make 'REGULAR'
Echo This installs Ready!, Super-
    Key, and SideKick
Echo on
Copy autoexec.reg autoexec.bat
Copy config.reg config.sys
Echo off
Echo NOW RESET SYSTEM
```

Similar batch files are MAKEDV.BAT, which sets things up to install DESQ-view; MAKEFRAM.BAT, which sets up to install Framework; and so on. Fast Kat resets very quickly, so it's no inconvenience. All of this is so obvious, I wonder why it took me so long to think of it.

Q&A

I've had Q&A version 2.0 for the 80386 for most of the month, and I like it a lot. There are more powerful database programs, and there are certainly better text editors; but I think there isn't a much better combination database and word processor, and each of them separately is a great deal better than good enough. The main attraction, though, is that there's nothing easier to use right out of the box.

Q&A isn't perfect. The original version ate memory like mad, and so does this version. This is because of an artificial intelligence routine called the Intelligent Assistant. There aren't any small and compact AI programs. If you run Q&A without the Intelligent Assistant, it's not much larger than other database programs. Q&A for the 386 is partly written in 386 native code, but it doesn't take much advantage of extended memory. Symantec says they'll change that.

Another problem with the new Q&A is the manual. Unlike the original, this one isn't loose-leaf. It's spiral-bound in two parts. That probably wouldn't be a problem for some people, but it is for me. The two volumes are very different in size. Volume II is quite thin. I'm always losing it—and it contains the index, so then it's nearly impossible to find anything in Volume I. This is a dumb way to organize material. I've ended up digging out the old loose-leaf manuals for version 1.2. They're not seriously out of date.

On the good side, Q&A for the 386 is

POWER TOOL.

Introducing 4x488™

see page 74

You get intelligent IEEE-488 and RS232 ports to make instrument programming fast and easy.

You can have up to 4 Mbytes of memory on the same board for your largest programs, RAM disks, and data acquisition tasks.

Compatibility is built-in so you can run your favorite programs or create new ones with our advanced programming tools.

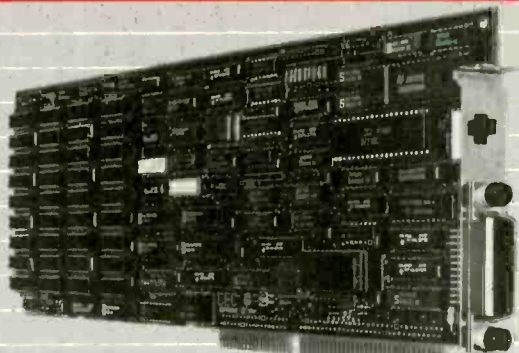

To get your FREE demo disk,—call 617-273-1818.

Capital Equipment Corp.
Burlington, MA 01803



The bottom line — IEEE-488, RS232, par. port, 4MB EEM LIM, runs DOS and OS/2.

CHAOS MANOR

blazingly fast. Moreover, it not only runs fine under DESQview, the DESQview script (key-swap and macro) capability lets you improve Q&A quite a lot. Q&A has a pretty powerful macro capability of its own, but it's not always as convenient to use as DESQview's.

For example, the Q&A people went to considerable trouble to make the backspace work differently when in type-over and insert mode. I'm not used to that; I want the backspace to be the Rubout key that both deletes the letter to the left of the cursor and sucks up the empty space formerly occupied. It was no great trick to use the DESQview macro capability to set things so the backspace does that all the time. Since Q&A's word processor automatically reformats paragraphs with every insert/delete, no monkey motions were needed.

The Q&A word processor is plenty good enough for just about everything I'm likely to do, but if that were all there was to the program, I'd never use it; TNT Software's MyWord and Bob Wallace's shareware PC-Write both pack more features and cost quite a lot less; and some of Q&A's editing features are not particularly easy to use.

As an example, to get a word count, you must go into search mode, then search on the wild card for "any word" (which happens, in Q&A, to be '..'). That uses a lot of keystrokes, and for what? Also, to get line counts, you have to do arithmetic; there's nothing corresponding to WRITE's command that tells you words, lines, and paragraphs before cursor, after cursor, and for entire document in one (almost instantaneously executed) command.

So: the word processor is easy to learn and better than adequate, but not spectacular. The big deal with Q&A is that it's an easy-to-use database.

It certainly is easy to learn. When Mrs. Pournelle decided to try organizing some of the flood of software that pours into Chaos Manor, she had to choose a database program to do it with. Heaven knows we have enough of them around here. She'd never before worked with a computer database, and I didn't have time to tell her anything. She was on her own.

She looked through the manuals of about a dozen and chose Q&A as the simplest to set up. First thing I knew about it was when I came downstairs and found one of the editorial assistants happily logging in software data.

A couple of weeks later, I got involved with Sundog, a computer game written originally for the Apple II by my friend and colleague Bruce Webster. Sundog has been ported to the Atari ST, and it's

The word processor with Q&A is easy to learn and better than adequate, but not spectacular. The big deal is that Q&A is an easy-to-use database.

my kind of game, which is to say there's a little arcade skill involved, but it's mostly strategy. Part of that strategy is commodity trading; and in Sundog that can be complex.

In fact, the game information was so complex I found myself wanting a database program to organize it; and since I needed a way to test Q&A for myself, this seemed a good way to do it.

A Database for Sundog

I had the same experience Mrs. Pournelle did, namely, that it took almost no time to get things set up. Q&A organizes records as "forms," and designing a form is literally no trick at all. Of course, I wasn't sure what information I wanted, or how to organize it, but that didn't turn out to be difficult, either.

Sundog is a complex game. There are about a dozen solar systems, each with one to four planets. Each planet has from one to seven cities. Each city has an exchange building located randomly inside its boundaries. The exchanges offer a variety of commodities, but not all commodities are offered at all exchanges.

Each commodity comes in grades A (best) through G (worst). Prices for commodities in various grades vary from planet to planet, and from city to city on each planet. You can get information about prices in a particular city only by visiting that city's exchange and either offering to sell something you've brought or waiting to see what's offered for sale.

One object of the game—or at least a necessary action—is to make money through buying commodities in one place, transporting them to another, and selling them. Of course, if you buy inappropriate items for the place you're going, you can lose money, especially since fuel isn't cheap.

To make things even more complicated, the game lets you engage in black-market trading of ship and computer parts. These don't come in grades (al-

continued

Now Your Computer Can See!

Two camera designs for scientific, engineering, art, graphics and OEM applications.

Plug one of these digitizing cameras into your personal computer, focus the lens, and produce immediate visual input. A binary image is instantly loaded into the MOS-sensor-based memory array, from which it can be reviewed and manipulated like any other binary file.

MicronEye™
\$295.00

Produce inexpensive digitized images for desktop publishing, graphics, drafting, signature recognition, animation and a variety of other applications. The MicronEye™ is extremely versatile for photographing flat and 3-dimensional subjects, and provides instantaneous response. Multiple exposure capability allows a range of gray scale values. Available now for IBM PC and compatibles, Apple II, Apple Macintosh and Commodore 64.



Idetix™
\$695.00

For rugged industrial applications, the high-speed Idetix™ camera offers enhanced still and multi-interval imaging capabilities that are ideal for process control, factory inspection and robotics applications. Available now for IBM PC and compatibles.



Each camera comes complete with lens, cable, interface board and introductory software. Custom engineering and applications assistance are available.

For Credit Card and C.O.D. orders, or for further information, phone toll free:

1-800-253-2226

In Idaho, phone (208) 939-0420

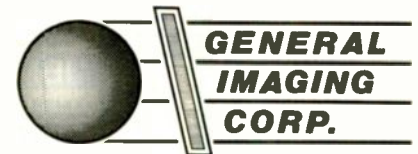

P.O. Box 9000 • Boise, Idaho 83707

MicronEye™ and Idetix™ are manufactured by
Micron Technology, Inc.

Shipped UPS—add \$10.00 for shipping and handling; \$1.90 C.O.D. charge; please add applicable sales tax.

IBM PC is a trademark of International Business Machines. Apple II and Apple Macintosh are trademarks of Apple Computer, Inc., Commodore 64 is a trademark of Commodore Corp.

Q&A is, after all, a file management program, and what I have here is a relational-database problem.

though you could consider them all to be of grade A) and aren't bought and sold in exchanges; to buy, you generally go to a parts store on a high-tech planet, and to sell, you generally go to a bar.

Finally, there is information about the cities themselves; information unrelated to any commodity. Things like, does the city have parts stores? What do they look like? Where is the exchange? (You can spend half an hour of real time looking for it if you haven't made notes.) What's the price of beer and hamburgers? (This gives a good indication of the general price levels for the city as a whole.)

This makes for a complicated database. When I started, I set it up so that a record consisted of the name of the star system; planet; city; commodity; grade;

price; and I left fields for comments. I certainly don't have information about all commodities or all grades for each city. On the other hand, if I find that in one city the price for grade D biochips is higher than the price for grade B in another city, I don't need to know more to get a handle on the profit to be made in that commodity.

Q&A is admirable for organizing information like that. Once I had my database established, I had it print out reports: one set was organized alphabetically by commodities, so that any time I needed to buy a given commodity, I could look up all the places that commodity might be available and the price I'd be likely to pay; and another report was organized by cities, so that I could look up for any given city what commodities I'd been offered and what they sold for.

Q&A could handle other information, but organizing it wasn't quite so simple. In fairness, what I have isn't a simple problem. For example, how to preserve general information not associated with commodities? Do I note the location of the exchange in a field on a typical form with commodity information, and thus have that blank field on most entries; or do I put it on a special form with the com-

modity information blank; or do I make a special file that contains only that information?

No database easily handles this kind of problem. What I really need is a pair of linked relational databases, as well as some ingenuity in modeling my data problems. Q&A certainly does this as well as most, and because it's comparatively easy to add new data fields, or even get the Intelligent Assistant to make new databases from your old one, I was able to work around the difficulty. Q&A is, after all, a file management program, and what I have here is a relational-database problem. More on this in the next few months.

Meanwhile, my main problem was that blanks are sorted to the beginning of a report, and sometimes my reports had un-aesthetic blank-line entries at the top when printed out.

Another example: suppose I know that in the city of DraheW I can buy grade C droids for 10,000 and grade E for 9000. A good guess would be that grade D sells for 9500; it would sure be nice if I could make the computer go through the database and fill in blanks everywhere through interpolation and averaging. Of

continued

UNINTERRUPTIBLE POWER SUPPLY

The SHIMON UPS-300W, UPS-400W and the UPS-600W provide high efficiency (80%), reliable battery back-up power protection for systems of all sizes. Made with internal lead-proof gel cells for safe office use. These units are the most reliable we have found, and we recommend them.

- UPS-300W.....\$239.95
- UPS-400W.....\$379.95
- UPS-600W.....\$675.00

1. High efficiency
2. Internal MC-8PILL test
3. Audible power loss
4. Fast transfer time
5. 2 outlet outlets
6. Transient filtering



Dealers welcome.....ASK

ASTEC 200W AT POWER SUPPLY



ASTEC 200W AT SUPPLY..\$129.95

We call the ASTEC AT power supplies because they are 100% good reliable units. With full FCC, UL and CSA approvals so you know they are good. After all why put a few thousand dollars of good USA made stuff on one of those EL-CHEAPO power supplies you see for a bit less money. Most of those have no +12V regulation, so they fry hard drives all the time. And the warranty is no good because it won't replace what was burned up. All they will do is give you another dog so you can burn up some more good stuff.

KEYTRONICS RT-101 KEYBOARD



100% AT/XT compatible
RT-101 \$99.95

Our reasons for selling the KEYTRONICS RT-101 keyboard are similar to those for selling the ASTEC power supply and the ATTACK-386 mother board. NO-ONE was ever burned by good quality merchandise. What can we say? Keytronics is the acknowledged world leader in keyboards. They run for-eva, they feel very good, they look very good, and they are only slightly more money than the TAIWAN junkies. Why is this? KEYTRONICS has a robot plant so their labour cost is as low as Taiwan's, the only one to good parts. And they are like good sets... no idiosyncrasy, have a nice feel.

AT SYSTEM KITS

DELUXE AT KIT.....\$999.95

Our AT system kits are made with the famous ATTACK-386 motherboard. What a deal. We send you our ASTEC-300W power supply, a nice PLURTOP AT case, an ATTACK-386 motherboard with 618K of RAM, a DTC hardfloppy drive controller, a PANABONIC 1.2M drive, and a KEYTRONICS RT-101 keyboard. This means you can have a full AT compatible system at a very low price.

STANDARD AT KIT.....\$799.95

We also have a lower cost kit for those of you who need to save as much money as possible. The only change in the keyboard will be a BTC 600K, the drive controller a 300K/1 floppy only controller, and with zero K RAM on board.

BASIC AT KIT.....\$599.95

And for those who want just the basics we have the basic AT kit. Just an ATTACK-386 motherboard, an ASTEC-300W Power Supply, and a great AT Flip-Top case.

Ten "MHz" option, add \$89.95 to above prices on each kit

XT SYSTEM KITS

COMPLETE 8MHz XT TURBO KIT BARE BONES 8MHz KIT

- * Flip-top case
- * 180W Power Supply
- * 8180 AT/XT Keyboard
- * 8MHz Turbo with 640K
- * Drive card & Cable
- * 2 Panasonic drives
- * Video card Cirronemo
- * Clock/calibrator ports
- * 10 diskette software
- * Full assembly manual.

This is a minimum system kit so you can pick and choose all the option cards you need.

\$599.95 \$249.00

All the above kits are made with good quality parts and are warranted for 30 days. The manual is very good and anyone can make a kit in an hour or less. Kit builders assume full responsibility for obtaining FCC approval for finished kits.

IBM PERIPHERALS

- NEW MULTI HD + VIDEO CARD, MAKES A SINGLE CARD KIT.....\$139.95
- A great new card with Drive, Clock, Bar Pin, Gamma, + Video/RGB/TL+horizo.....\$74.95
- NEW SHORT VIDEO-PRINTER CARD.....\$74.95
- A 7715B/C, with printer Hercules or RGB (optional), both same price.....\$399.95
- NEW BABY AT MOTHERBOARD 8-16888E.....\$299.95
- RT case, needs 1 MB, an AT case, AWARD BIOS, Flo XT case.....\$219.95
- BABY AT PLURTOP CASE + POWER SUPPLY.....\$219.95
- "MAAC" case, 14" case for small laptops, uses 2 floppy 1 HDD.....\$94.95
- NEW MULTI HD SHORT CARD WITH LSI CHIPS.....\$94.95
- 60 MO or 1.2 MB 100 Pin Clock, Cal, Gamma Drive, as you need for 2 card system.....\$249.95
- NEW ENHANCED GRAPHIC ADAPTOR.....\$249.95

AT/XT are reg trademarks of IBM Inc. Video Graphics Pr...\$89.95
Color graphics.....\$89.95
MULTI HD.....\$94.95
MultiFunction RAM \$79.95
Printer.....\$89.95
Parady drive card \$39.95
RS-232C.....\$94.95
RS-232C/Color/cal.....\$44.95
Game IO.....\$24.95
Clock/cal.....\$24.95

Computers For The Blind

Talking computers give blind and visually impaired people access to electronic information. The question is how and how much?

The answers can be found in "The Second Beginner's Guide to Personal Computers for the Blind and Visually Impaired" published by the National Braille Press. This comprehensive book contains a Buyer's Guide to talking microcomputers and large print display processors. More importantly it includes reviews, written by blind users, of software that works with speech.

Send orders to:

**National Braille Press Inc.,
88 St. Stephen Street, Boston, MA 02115
(617) 266-6160**

NBP is a nonprofit braille printing and publishing house.

COMPUTER PARTS GALORE INC CALL TOLL FREE
56 HARVESTER AVE BATAVIA
NY 14020 1-716-343-6133
IN CANADA 1-800-387-1385



USE THE BRAINS YOUR IBM WASN'T BORN WITH.

Right at your fingertips in CompuServe's IBM® Forums.

Our IBM Forums involve thousands of users worldwide who will show you just how easy it is to get the most from your IBM and IBM compatibles.

The IBM New Users Forum lets you ask basic questions of PC experts. The IBM Junior Forum is perfect for PCjr® users. Trade tips with other IBM PC and AT users in the IBM Software Forum. Ask questions and get answers directly from the manufacturers in the PC Vendor Support Forum. And if you're looking for a PC Bulletin Board, visit the IBM Communications Forum. Or try the IBM Hardware Forum for discussions on hardware topics and product updates.

Easy access to free software, including free uploads.

You can easily download first-rate,

non-commercial software and utility programs. Upload your own programs free of connect time charges. And take advantage of CompuServe's inexpensive weeknight and weekend rates, when forums are most active and standard online charges are just 10¢ a minute. You can go online in most areas with a local phone call. Plus, you'll receive a \$25.00 Introductory Usage Credit when you purchase your CompuServe Subscription Kit.

Information you just can't find anywhere else.

Use the Forum Message Board to send and receive electronic messages. Join ongoing, real-time discussions in a Forum Conference. Communicate with industry experts, including the programmers who write your favorite programs. Search Forum Data Libraries for non-commercial software and shareware.

Enjoy other useful services too, like electronic editions of popular computer magazines.

All you need is your IBM computer or IBM compatible computer (or almost any other personal computer) and a modem.

To buy your Subscription Kit, see your nearest computer dealer. Suggested retail price is \$39.95. To receive our free brochure, or to order direct, call 800-848-8199 (in Ohio and Canada, call 614-457-0802). If you're already a CompuServe subscriber, type GO IBMNET (the IBM Users Network) at any ! prompt to see what you've been missing.

CompuServe®

Information Services, P.O. Box 20212
5000 Arlington Centre Blvd.,
Columbus, Ohio 43220

800-848-8199

In Ohio, call 614-457-0802

An H&R Block Company

Inquiry 55

Now Available!
The Best of IBMNET
Nearly 600 software file listings
Type GO ORDER or call CompuServe



CLEO is your SNA or BSC Gateway

Remote Sites Communication

Whatever your industry, your remote computers need to share information with your mainframe. Or, they need to exchange data with other remotes. In either case, you need a total solution at the remote sites. You need software, hardware interfaces and modems that all work together smoothly. You need CLEO!

CLEO software products allow micro-computers to communicate with mini-computers and mainframes, and to emulate their workstations. Since 1981, CLEO has provided remote communications between micros and mainframes for the automotive, insurance, medical and banking industries. Today over 44,000 CLEO users worldwide are running on all major brands of micro-processors. The greatest number of these users run CLEO software on IBM Personal Computers and NETBIOS LANs.

Complete Software/Hardware Package

Every CLEO package contains all the software and hardware accessories needed at the remote site. Your selected CLEO SNA or BSC software is packaged with 1) an internal modem card for dial-up applications, or 2) an interface card and cable for use with your existing modem. There's no waiting for non-CLEO add-ons. And, you get prompt, single-source service.



Package prices range from \$795.00 for most stand-alone packages, up to \$2,995.00 for the 32-user SNA gateway.

Call us today to discuss your application.

CLEO Software
1639 North Alpine Rd.
Rockford, IL 61107
Telex 703639

Headquarters:

USA: 1-800/233-2536
Illinois: 1-800/422-2536
International: 815/397-8110

Sales and Distribution:

Benelux, Scandinavia: 31 (71) 899202
Canada, East: 800/361-3185
Canada, West: 800/361-1210
Canada, Montreal: 514/737-3631
Colombia, S.A.: 12875492
Denmark: 451 628300
Italy: (0331) 634 562
Mexico City: 203-0444

CLEO 

CLEO and 3780Plus are registered trademarks of CLEO Software. IBM is a registered trademark of International Business Machines Corporation.

course, I don't know any other program that can do that.

Finally, what I'm really looking for is the largest spreads. I don't really care what commodities I trade in; what I want is the largest profit for the shortest trip. Can I make the computer find me the best possible deals?

Intelligent Reports

As I mentioned earlier, Q&A has an AI routine—written originally in LISP, as a matter of fact—called the Intelligent Assistant. This makes report generation and database manipulation much easier. For instance, I can, with patience, tell the Assistant to go through and make new forms based on information derived from the old ones and present the information in interesting ways.

Intelligent Assistant can be taught all manner of things. It knows the difference between verbs and adjectives. You can teach it a new vocabulary, and since it has automatically learned a lot about the database the first time it's invoked, it's easy to give it synonyms. I can do a lot with the Assistant, and it's easier to use every time I try.

On the other hand, I haven't been able to get the Assistant to give me much help finding the most profitable deals. It's easier to print out the data organized in different ways and search through myself.

Q&A uses a menu system. The menus are one of the main reasons why Q&A is so easy to learn and use, and I wouldn't change them for the world, especially since there's context-sensitive on-line help at all stages, from database creation to report design. Sometimes, though, the menus get in the way when I'd like to jump from one place to another. Macros do only part of the job. Oh, well, you can't have everything.

I suppose it's a bit silly to complain on the one hand that Q&A is a memory hog, and on the other to wish for new features. Of course, it wouldn't be impossible to get Q&A smarter and effectively smaller by using the 386's capabilities.

Q&A is both easy to learn and easy to use. There are lots of features and utilities to help import data from other databases, including PFS:File, dBASE II and III, and Lotus 1-2-3, so the data can be re-organized. With Q&A, it's particularly simple to add new categories of information you didn't think of, and the Intelligent Assistant helps a lot. Q&A is fast. For most jobs, it's more than good enough. The next step up is something like Guru from Micro Data Base Systems, and that's complex, not easy for beginners to learn or use, and quite expensive. The bottom line is that Q&A is what I find myself using at Chaos Manor for

everything from games to organizing the files.

Fixing WordStar

There are a lot of new text editors out, but it's amazing how many people still use WordStar. Clearly, there's a dance in the old girl yet.

Serious WordStar users may want to get WordStar Professional 4.0, which fixes a number of complaints people had about version 3.3 and adds new features—but there are some disadvantages to that. When MicroPro married WordStar and NewWord to produce 4.0, they made some changes in the file, menu, and command structures. Most of the changes were trivial, but some weren't, so there can be some incompatibilities between old and new WordStar files.

For those who really like the look and feel of the old WordStar, there may be a better route. Over the years, user's groups have built a body of folklore on ways to customize WordStar by patching the code. Patching means using DDT, Debug, or a similar utility to modify a copy of the command file; it's simple enough to do, provided you know what has to be done.

You can find tips on how to modify

WordStar on both free and commercial bulletin boards, in user's group publications, or in conversations at computer club meetings. But if you want to go at it systematically, the simplest way is to get hold of the following two items.

The first is Stuart Bonney's *The Wordstar Customizing Guide* (Wordware Publishing, P.O. Box 1747, Plano, TX 75074, (214) 423-0090). This used to be called *Wordstar As You Like It*, and it features a pretty complete presentation of how to use Debug to customize WordStar. It has an excellent discussion of WordStar's hidden proportional spacing capability and goes into principles of printer installation. There's a supplementary section for CP/M users. If you use WordStar at all, this book is worth the price.

If you're really serious about patching WordStar, you need StarFixer by Stephen Manes and Paul Somerson (Bantam Books, but you can get your copy directly from the authors at Hard/Soft Press, P.O. Box 1277-B, Riverdale, NY 10471, (800) 222-9409). This package bills itself as "The Ultimate WordStar Enhancement." I suspect MicroPro would say that WordStar 4.0 has a better claim to that

continued

UTAH

COBOL™

NEW

VERSION 4.0

\$ 69.⁹⁵

For IBM®PC's, XT's, AT's and other DOS machines. This is the one you've heard so much about – with fast compile times, small object code modules, no royalties, and clear error messages. Version 4.0 is based upon ANSI-74 standards with new features including:

- Multi-key Indexed files with up to 24 keys. This advanced feature requires the software package Btrieve® which is optionally available.
- Windowing, pop-up's, color and overlays. This advanced feature requires the software package Saywhat?!™ which is optionally available.
- ACCEPT numerics with decimal point alignment, numeric checking, AUTO-SKIP, SECURITY, LENGTH-CHECK, EMPTY-CHECK.
- Fast memory mapped DISPLAY's (1, 5) ERASE, BEEP, ATTRIBUTE.
- Level 88's – READ INTO – WRITE/REWRITE FROM – and DELETE.
- An easy to use, COBOL source code EDITOR with auto line numbering, A-margin, B-margin tabbing with full screen cursor control.

Current customers can receive the new version by sending in their original diskette and \$30.00. This offer expires Dec. 31, 1987

Also available: Utah FORTRAN, Utah BASIC, Utah PASCAL, Utah PILOT, Btrieve and Saywhat?!. Used by 50,000 professionals, students and teachers in 40 countries.



SINCE 1977

ELLIS COMPUTING™

5655 Riggins Court, Suite 10

Reno, Nevada 89502

To order call:
(702) 827-3030

IBM is a registered trademark of International Business Machines, Inc. Btrieve is a registered trademark of Softcraft, Inc. SAYWHAT?! is a trademark of The Research Group. Utah COBOL is a trademark of Ellis Computing, Inc. © 1987 Ellis Computing Inc.

SAVE UP TO 70%

CAD

SOFTWARE & PRINTERS

PRINTERS & LASERS

Alps	Call	Nissho	Call
AST TurboLaser	Call	Okidata	Call
Citizen		Panasonic	
120 D	\$159	1080	\$153
MSP-10	\$249	10911	\$167
MSP-15	\$319	10921	\$289
MSP-20	\$279	1592	\$370
MSP-25	\$375	1595	\$399
Overture 110 Laser	\$1599	3131	\$250
Premiere 35	\$429	3151	\$275
Tribute 224	\$579	Toshiba	
Dicomax 150	\$289	321 SL	\$479
Fujiisu	Call	341 E	\$649
H-P Laser Jet 500	Call	341 SL	\$989
JDL	Call	351 II	\$688
NEC	Call	351 C	\$1029
CHIPS 64k, 256k, 8087, 80287			Call

MONITORS & TERMINALS

Amdek		124 A	\$95
1280	\$674	635 Ultra HiRes RGB	\$378
Goldstar		650 Ultra HiRes RGB	\$439
TTL	\$70	720 14" HiRes	\$315
RGB	\$229	770 14" MultiRes	\$559
RGB 31	\$289	Teknika Multi-Scan	\$469
Mitsubishi	Call	Thompson Ultrascan	\$569
Diamond Scan	Call	Verticom CO-5	\$1998
Others	Call	Viking 1 & 10	Call
NEC Multisync	\$529	Wyse	Call
Multisync Plus	Call	30	\$282
Multisync XL	Call	50	\$356
Sigma Designs		60	\$399
LaserView 15	\$1590	75	\$559
LaserView 19	\$1890	85	\$419
Sony Multiscan	Call	99GT	\$498
Taxan		700	\$674
123 G	\$85	Others	Call

SOFTWARE

Autocad	Call	Logitech Publisher	
AutoSketch	\$59	& Mouse	\$119
BoeingGraph	\$219	Lotus 123 2.01	\$296
CPA+ for Lotus 123	\$279	MathCad	\$189
Clipper	\$365	MemoryMate	Call
dBase III Plus	\$365	Microsoft Word 3.11	\$199
Diagram Windows	\$299	MSDOS 3.2 w/Basic	\$65
Drafix 1	\$289	NewViews	\$479
Drafix 1 Plus	Call	Paradox	\$369
Drafix Options	Call	PathMinder	\$49
Dr. Halo II (Hd qty)	\$29	Peachtree Accounting	\$159
EasyCad	\$279	Perspective 3D	\$159
Enable 2.0	\$355	PFS First Choice	\$81
Fast Forward	\$59	PFS First Publisher	Call
FastCad	\$1298	PFS Professional File	\$110
FastBack Backup	\$85	PFS Professional Plan	\$99
FullBack Backup	\$49	PFS Professional Write	\$87
Gen Publisher	\$299	R-Base 5000 Sys V	\$345
Generic Cadd 3.0	\$55	Tas-Books Accing & Dbase	\$85
Generic Opt	Call	V-EMM	\$68
Harvard Presentation		Ventura Publishing	\$479
Graph II	\$194	VersaCad & Libraries	\$479
Lighting Speedup	\$54	WordPerfect 4.2	\$192
LogiCadd & Mouse	\$119	WordPerfect & Library	\$235

DIGITIZERS & PLOTTERS

Calcomp		Hitachi	
1041	Call	Tiger 1111C	\$399
1043	\$6790	Others	Call
Digitizers	Call	H-P Plotters	Call
Enter		Ioline	Call
Sweet-p 600	\$639	JDL	Call
1000	\$2690	Kuria	Call
1200	\$2990	Mitsubishi Digitizers	
Houston Instruments		Grainet-01 8x12	\$260
DMP 41/42	\$2298	Grainet-02 13x16	Call
DMP 51/52	\$3298	Nunomics	Call
DMP 52MP	\$3698	Summagraphics	
DMP 56A	\$4098	Summa 12x12	\$339
MP Options	Call	Others	Call

COMPUTERS

AST Premium 286	Call	Toshiba	
Compaq	Call	T1100	Call
Cordata	Call	T1100/T3100	
IBM	Call	Modern H.M.	\$219
NEC	Multispeed Call	T3100	\$2755
Sperry IT (AT) Enhanced	Call	Wyse pc/286	\$1299
40 Meg	\$2599	Zenith 181 Laptop	\$1629

BOARDS & NETWORKS

Aristocats	Call	Others	Call
AST Boards	Call	NEC GB-1	\$299
ATI		Novell	Call
Graphics Solutions	\$169	Number 9	Call
EGA Wonder	\$219	Paradise	
Control Sys Artist	Call	AutoSwitch EGA 480	\$279
Genoa SuperEGA	\$318	Photon	Call
Hercules		Sigma Designs	
Color	\$139	EGA AutoCard 480	\$249
Graphics Plus	\$171	Color 400	\$289
InColor	\$359	Verticom	Call
Intel		Video 7	
Above Board AT	\$311	Vega Deluxe w/VGA	\$275
Above Board PS/AT	\$341	Others	Call
InBoard	386/AT \$1436		

DRIVES MODEMS FAX

Fujiisu 5.25 360k Drive	\$79	SmartModem 1200i	
Hayes	Call	& SW	\$85
MicroFax	Call	SmartModem 2400e	
Novell	Call	& SW	\$199
Modem T1100/T3100		Toshiba 35 XT/AT	
Z181	\$219	720k Drive	\$115
PhoneFlex	\$169	US Robotics	
Seagate		Courier 2400	\$329
ST225 20 w/Card	\$309	MicroLink 2400	\$326
ST238 30 w/Card	\$359		

MOUSE & ACCESSORIES

Logitech		MicroSoft Mouse	
Logimouse C7	\$65	w/Paint	\$115
Logimouse Bus	\$89	PC Mouse/Optimouse	
		w/Halo II	\$97

M.H.I. WAREHOUSE

5021 N. 20th Street #10261 • Phoenix, AZ 85064
TOLL FREE with order • 602-995-1134
Hours 8-5 MT M-F 9-2 SAT

Prices subject to change and are subject to change without notice. Components of products not guaranteed all returns are subject to a restocking charge. Payment in U.S. dollars only. All items are sold as-is. All prices are in U.S. dollars. All prices are in U.S. dollars. All prices are in U.S. dollars. All prices are in U.S. dollars.



Eureka is powerful enough to get most engineering and financial jobs done.

title, but it's not really misleading.

StarFixer comes with a disk of programs that will "automagically" do a lot of customization without having to load Debug. There's a Rescue program that will retrieve text if you exit WordStar without saving and a Filter program that will convert WordStar files into ASCII. Finally, there's a discussion of how to use Debug to do even more advanced modifications of WordStar.

Bonney's book has somewhat clearer discussions of what you're doing and why, while StarFixer is generally more complete, and its programs are easier to use. Both are just about indispensable for anyone doing professional work with WordStar. Recommended.

Eureka!

It used to be that if you got a small computer, you'd sooner or later be surrounded by scornful philistines demanding to know "What can you do with it that a calculator can't do?" It wasn't always easy to answer that question unless you were a programmer.

There have always been "math programs" for small computers, but they haven't been easy to learn. There's muMath, based on MIT's MACSYMA symbolic algebra program: extremely powerful, but complicated to get going and easy to forget if you didn't use it a lot. There was TK!Solver, not so powerful, but nearly as tough to learn. The ultimate, I suppose, was the language APL, which made child's play out of all kinds of hairy mathematical problems but was something between a hobby and a career to learn.

Now there's Borland's Eureka: The Solver. It's not as powerful as APL or muMath, but it will get most engineering and financial jobs done. It's very easy to use. The manual is clearly written, and there are plenty of examples. You can get Eureka up and running in about five minutes.

My first Eureka task was elementary planet design. As Poul Anderson put it in the old *SFWA Handbook*, "Far too many stories merely give us a planet exactly like Earth except for having neither geography nor history. Other stories, trying for the exotic, serve up an unbelievable mishmash." The remedy to that is to use

imagination but fit what you imagine into the equations that govern the real universe.

For example, the size of a sun pretty well determines both its color and brightness. The illuminance a planet will receive is determined by the solar luminosity and the distance to its star

$$i = L/R^2$$

(where i is illuminance received relative to what Earth gets from Sol, L is the star's luminosity relative to Sol, and R is distance to the star relative to Earth's distance from Sol). The planet's year is determined by that distance and also the star's mass ($MP^2 = R^3$, where M is stellar mass relative to mass of our sun, P is the period in years, and R is the distance relative to Earth's distance from the sun). The apparent size of the star as seen from the planet depends on distance and stellar diameter. And so forth.

To design a planet, you pick the numbers you want and stuff them into the equations, then solve for everything else. This isn't hard, but it used to be tedious. Eureka has changed all that.

When you invoke Eureka, you come up in the Borland editor that's used for nearly all their programs. You then write your equations using pretty standard notation (e.g., $M \cdot P^2 = R^3$ and $i = L/R^2$), then set the values you want fixed (e.g., by writing $i = 0.97$, $L = 0.93$, and so forth), then turn Eureka loose. It will give self-consistent values for every variable in your equations. If some of those values turn out not to your liking, you can change them. If you fix too many of the variables so that the system of equations is no longer self-consistent, Eureka will tell you that. The whole process is nearly instantaneous and completely painless.

Of course, you can use Eureka for a lot more than planet design. The manual gives examples of solving financial problems, like mortgage payments, ballistic problems, polynomials, charged particles in a gravitational field, and a whole bunch of other stuff.

Eureka can make graphs and generate reports. It doesn't require a math chip, but it will automatically use one if your computer has a math chip installed.

I've often said that if I could do arithmetic, I might well have become an astrophysicist. I understood high school and college physics, but I got lousy grades because, although I set up the equations right, I never got the right answers. If I'd had a PC and Eureka, I would have.

Borland's blurb says that "if you're a scientist, engineer, financial analyst, student, teacher, or any other professional

continued

From 360K to 70MB,
we've still got your number.

**NOW,
Even Lower Prices.**

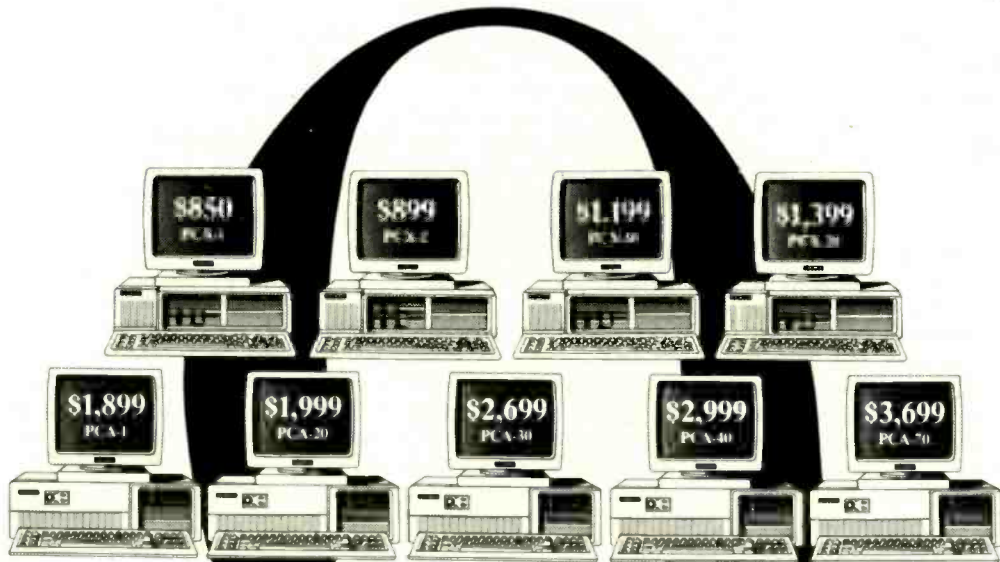

The best value in personal computing just got even better. We've added more standard features while lowering our prices* even further. Starting at an incredible \$850, our XT-compatible workstations now come with a standard dual video adapter and a serial port.

In our line of AT-compatibles there is a choice of five models, starting at a low \$1,899. And all come with additional standard features such as a powerful 1MB of main memory, a serial port and a parallel port. And at prices that are consistently around 40% less than our major competitors.

But a low price doesn't mean you have to sacrifice quality. Tandon personal computers are brought to you by a trusted manufacturer who has been an industry leader for over a decade.

For the Tandon dealer nearest you call toll-free 1-800-556-1234 ext. 171. In California call 1-800-441-2345 ext. 171.

Tandon Personal computers. With selection and price, we've still got your number.

Tandon
Price. Selection. Quality.

Please send me your Tandon Fact Pac, a comprehensive set of literature and product reviews.

Name _____

Position _____

Company _____

Address _____

City/State _____

Telephone _____

Tandon Computer Corporation
405 Science Drive
Moorpark, CA 93021
805/378-6104

BYTE 9/7

*Manufacturers suggested retail price. Monitor not included.

working with equations, Eureka: The Solver can do your algebra, trigonometry, and calculus problems in a snap." That's pretty well true. I'd add that eventually everyone has to deal with equations and numbers, and when it happens, Eureka will make it a lot easier. I'll go further: programs like this may go a long way toward correcting some of the deficiencies of our school system. A computer can't teach math, but with a PC and this program, you can learn to use math on your own.

Get Eureka. You won't regret it. Highly recommended.

Care and Feeding of Fixed Disks

Hard disks are wonderful, but after a while, reading and writing to them takes longer and longer. What happens is that when you start with an empty disk there's plenty of space available, and your files are written in one long string. As the disk gets full and you erase files, things get patchier and patchier until, finally, the space that's left is all chopped up, so that the disk controller has to keep looking for space, finding it, writing to it, and recording where it wrote it. This makes for a lot of head movement and takes time.

The remedy for that is to repack your disk every now and then. Several disk management programs are available, but

the one I use is Golden Bow's VOPT. This comes with VMAP, which paints a map of which disk sectors are in use and which are empty, and VOPT, which moves the files around so that everything that can be saved is saved in contiguous blocks. VOPT keeps track of how many files it has moved and how long it took; on the Zenith Z-248 and the Kaypro 386, that will typically be some 25 files moved in around 30 seconds.

It makes a real difference. As a test, I let my disk get cluttered and disorganized, then wrote an enormous text file to it, retrieved it, erased it, used VOPT to repack, and did all that again. Retrieving the file took about 16 percent less time after VOPT. Now I routinely use VOPT every couple of days.

VOPT comes with a jazzed-up version of the DOS utility CHKDSK, but for some reason the Golden Bow CHKDSK has never worked on either the Z-248 or the Kaypro 386. It hardly matters: VMAP and VOPT are what's important.

The other program you need is SpeedStor, which I mentioned last month. SpeedStor is a hard disk drive integration and diagnostic program that lets you install virtually any size hard disk in your system. I finally got around to partitioning Fast Kat's 40-megabyte hard disk, of which DOS could find only 32 mega-

bytes. Thanks to SpeedStor, it now has two 20-megabyte logical drives. (VOPT, incidentally, can operate on both of them with no difficulty.)

SpeedStor is especially useful if you're installing your first hard disk in a PC or XT. The manual is detailed, and since the program works automatically in batch mode for most hard disk installations, SpeedStor makes the installation fairly simple.

Winding Down

I'm out of time and space, and I haven't even got started on the pile I set out to write about.

I do want to mention Definicon's 68020 and graphics boards for the PC. Their boards drop into a PC and turn it into the fastest thing this side of a VAX; maybe faster. There's not a lot of software, but there are compilers. My matrix benchmark runs (in C) so fast you can't really measure it. Anyone doing serious software development ought to know about Definicon.

Then there's a flier from the good guys at The Software Toolworks reminding me that Chessmaster 2000 makes a great Christmas gift. I think they have a weird idea of BYTE deadlines, but, in fact, that's the best chess program I know of. There's a pile of stuff I collected at Spring COMDEX, including pc-ditto, which lets you run just about any PC program there is on your Atari ST. There's Borland's new C compiler and a big package of new stuff from Microsoft. It will all have to wait.

The game of the month (other than Sundog for the Atari ST) is Faery Tale Adventure for the Amiga. This has fabulous graphics and a pretty good story line. It's hard to get started—I kept getting killed in the first three minutes, so I never saw much of the scenery—but my son Phillip has definitely mastered the system and is able to romp about bashing bad guys.

The book of the month is Arthur Ferrill's *The Fall of the Roman Empire—The Military Explanation* (Thames and Hudson, 1986). Good reading and plenty of lessons for our time.

With any luck, by next month I'll have written some new text-handling benchmark programs. ■

Jerry Pournelle welcomes readers' comments and opinions. Send a self-addressed, stamped envelope to Jerry Pournelle, c/o BYTE, One Phoenix Mill Lane, Peterborough, NH 03458. Please put your address on the letter as well as on the envelope. Due to the high volume of letters, Jerry cannot guarantee a personal reply.

Items Discussed

Chessmaster 2000..... \$39.95 to \$44.95

The Software Toolworks
13557 Ventura Blvd.
Sherman Oaks, CA 91423
(818) 907-6789

DSI-785 68020 Coprocessor Board

12.5 MHz, 1 megabyte of RAM..... \$1094
20 MHz, 4 megabytes of RAM..... \$3295

Definicon Systems
1100 Business Circle Dr.
Newbury Park, CA 91320
(805) 499-0652

Eureka: The Solver..... \$99.95
Borland International
4585 Scotts Valley Dr.
Scotts Valley, CA 95066
(408) 438-8400

Faery Tale Adventure..... \$49.95
Micro Illusions
17408 Chatsworth St.

Granada Hills, CA 91344
(818) 360-3715

Kaypro 386..... \$5795
Kaypro Corp.
533 Stevens Ave.
Solana Beach, CA 92075
(619) 481-4300

pc-ditto..... \$89.95
Avant Garde Systems
381 Pablo Point Dr.
Jacksonville, FL 32225
(904) 221-2904

SpeedStor..... \$79
Storage Dimensions
981 University Ave.
Los Gatos, CA 95030
(408) 395-2688

VOPT..... \$49.95
Golden Bow Systems
P.O. Box 3039
San Diego, CA 92013
(619) 298-9349

Borland's Turbo Prolog, the natural introduction to Artificial Intelligence

Nothing says Artificial Intelligence has to be complicated, academic or obscure. Turbo Prolog® proves that. It's intelligent about Intelligence and teaches you carefully and concisely so that you soon feel right at home.

Which is not to say that Artificial Intelligence is an easy concept to grasp, but there's no easier way to grasp it than with Turbo Prolog's point-by-point, easy-to-follow Tutorial.

Turbo Prolog is for both beginners and professional programmers

Because of Turbo Prolog's natural logic, both beginners and accomplished programmers can quickly build powerful applications—like expert systems, natural language interfaces, customized knowledge bases and smart information-management systems. Turbo Prolog is a 5th-generation language that almost instantly puts you and your programs into a fascinating new dimension. Whatever level you work at, you'll find Turbo Prolog both challenging and exhilarating.

Turbo Prolog is to Prolog what Turbo Pascal is to Pascal

Borland's Turbo Pascal® and Turbo C® are already famous, and our Turbo Prolog is now just as famous.

Turbo Pascal is so fast and powerful that it's become a worldwide standard in universities, research centers, schools, and with programmers and hobbyists. Turbo Prolog, the natural language of Artificial Intelligence, is having the same dramatic impact.



Borland's new Turbo Prolog Toolbox adds 80 powerful tools

Turbo Prolog Toolbox™ includes 80 new tools and 8000 lines of source code that can easily be incorporated into your own programs. We've included 40 sample programs that show you how to put these Artificial Intelligence tools to work.

Already one of the most powerful computer programming languages ever conceived, Turbo Prolog is now even more powerful with the new Toolbox addition.

The Critics' Choice

“ I really wouldn't want to choose the most important MS-DOS product developed last year, but if I had to, I think it would be Borland's Prolog, which gives users a whole new way to think about how to use their computers.

Jerry Pournelle, 'A User's View,' InfoWorld

Turbo Prolog offers the fastest and most approachable implementation of Prolog.

Darryl Rubin, AI Expert ”

- Turbo Prolog Features:**
- ☑ A complete development environment
 - ☑ A fast incremental compiler
 - ☑ A full-screen interactive editor
 - ☑ Graphic and text window support
 - ☑ Tools to build your own expert systems
 - ☑ Full DOS access and support
 - ☑ A free Tutorial
 - ☑ The free GeoBase™ natural query language database
 - ☑ An easy-to-understand 200-page manual
- All this and more for only \$99.95!

- The new Turbo Prolog Toolbox includes:**
- ☑ 80 tools
 - ☑ 8000 lines of source code that can easily be incorporated into your own programs
 - ☑ 40 sample programs
 - ☑ Business graphics
 - ☑ File transfers from Reflex,* dBASE III,* 1-2-3* and Symphony*
 - ☑ Sophisticated user-interface design
 - ☑ Screen layout and handling—including virtual screens
 - ☑ Complete communications package including XMODEM protocol
 - ☑ Parser generation
 - ☑ Opportunity to design AI applications quickly
 - ☑ 5th-generation language and supercomputer power to your IBM®PC and compatibles
- Only \$99.95!



4585 SCOTTS VALLEY DRIVE
SCOTTS VALLEY, CA 95066
(408) 438-8400 TELEX: 172373

All Borland products are trademarks or registered trademarks of Borland International, Inc. or Borland/Analytica, Inc. Other brand and product names and trademarks or registered trademarks of their respective holders. Copyright 1987 Borland International

Inquiry 31 for End-Users.

BI-1120

Inquiry 32 for DEALERS ONLY.

For the dealer nearest you or to order by phone call
(800) 255-8008
in CA (800) 742-1133 in Canada (800) 237-1156

People who deal with "baud" of McGraw-Hill information.

Nobody understands the value of good information better than the people who work in computers and communications.

And for those people, no information carries more weight than McGraw-Hill's. We provide the databases, analyses and news that computer and communications professionals rely on to illuminate the workings of their industries.

Everyone in the business keeps up with the latest developments by reading McGraw-Hill maga-

zines. BYTE, Electronics and Data Communications are all required reading in the field. So are books from Osborne/McGraw-Hill.

For MIS/EDP and communications professionals, Datapro's print and on-line directories and reports cover every aspect of computer hardware and software, from mainframes to micros, as well as communications and office automation.

For people who manufacture or sell microcomputers and microsoftware, Future Computing is the

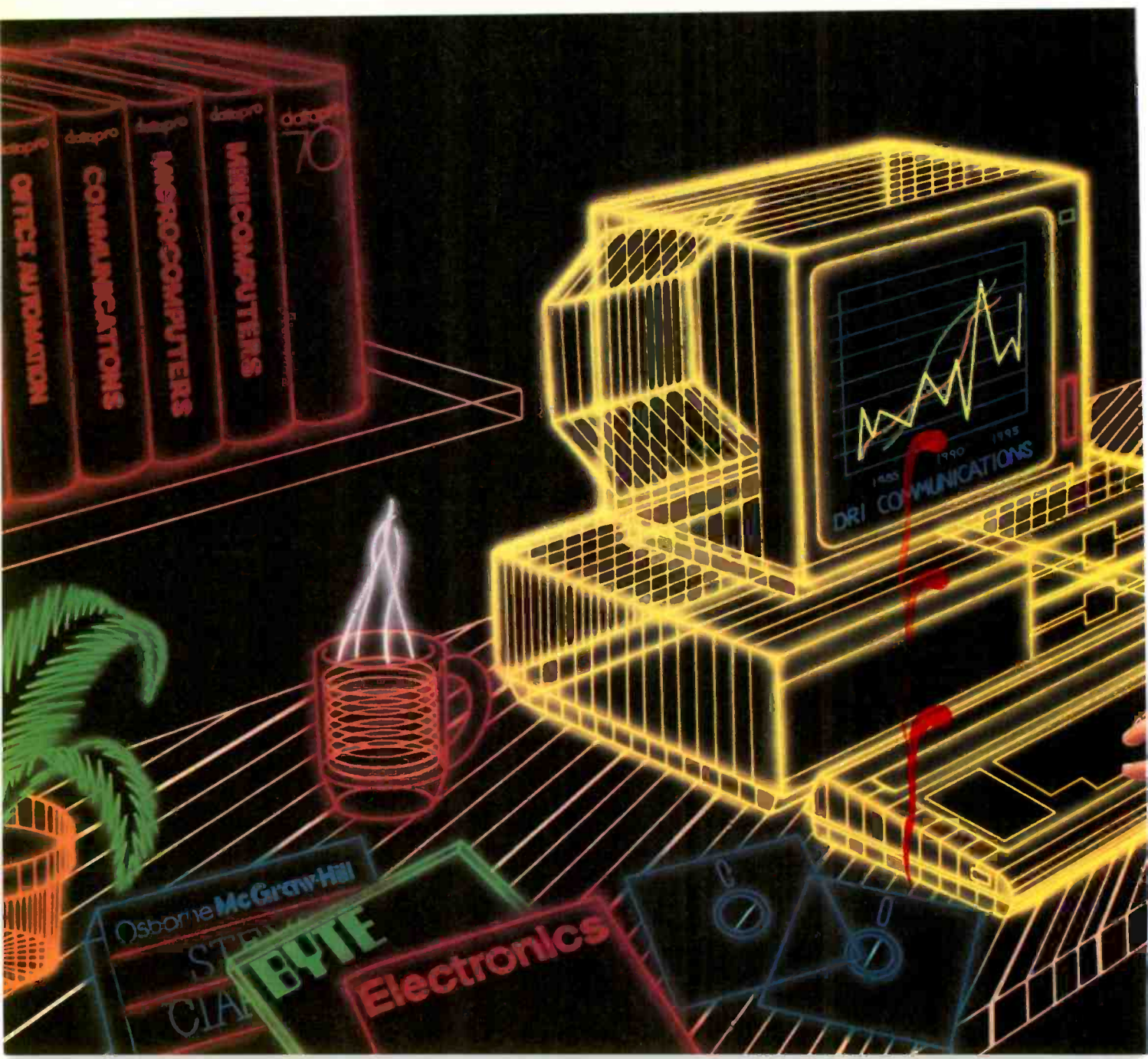

and "byte" use every bit

number one information source for product tests, analyses and comparisons.

People who specialize in communications are wired into CCMI/McGraw-Hill, to receive not only the hard facts on communications tariffs, but also in-depth analyses and bottom-line recommendations via print, software and on-line products.

And when telecommunications and computer companies plan for the future, they rely on DRI, Communications to provide them with forecasts

of economic forces and industry trends.

When it comes to turning megabytes into megabucks, nothing computes like McGraw-Hill information.

McGraw-Hill, Inc., 1221 Avenue of the Americas, New York, N.Y. 10020.

McGraw-Hill.
Information that leads to action.



Our Prices Are So Low They're Downright Embarrassing

TURBO XT

8088 - 4.77/8MHz
640K RAM, 8 slot multi I/O
Mono. monitor, graphics card
20 Mb hard drive, keyboard
1-360K floppy
150w Power
2 Yr. Lmtd. Warr. **\$795**

TURBO AT

80286 - 6/10 MHz
1 Mb RAM, 8 slot multi I/O
Mono. monitor, graphics card
40 Mb hard drive, floppy
Enhanced keybd.
200w Power
3 Yr. Lmtd. Warr. **\$1495**

MT 386

80386 - 4.77/6/8/10/16MHz
2 Mb RAM, 8 slot multi I/O
Mono. monitor, graphics card
80 Mb hard drive, floppy
Enhanced keybd.
200w Power
3 Yr. Lmtd. Warr. **\$2995**

Our low prices are leaving a lot of people red-faced.

Like manufacturers who charge twice as much for similarly-configured systems. And managers who paid twice as much for their company's computer equipment.

Our low prices include all the things that other manufacturers leave out — like monochrome monitors, graphics cards, and hard drives. SST Quantus business computers are complete, ready-to-run systems, featuring name-brand components. At unbelievably low prices.

So when you need high-performance computer systems at the right price, call SST. Anything else will leave you in the red.



QUANTUS

Scientific Storage Technology
One Butterfield Park, Spofford, NH 03462
(800) 255-0125 (603) 363-4564
(800) 356-9001

Potpourri

Ezra Shapiro

MemoryMate, Mirror II, Tracker, Oyster, Guide, and The Comic Strip Factory

I've bitten the bullet. The Macintosh Plus and the QMS laser printer live on, but my faithful Compaq is sitting in a corner gathering dust. I'm now running my MS-DOS programs on a Tandon AT clone, a PCA-40 to be exact, equipped with an EGA card and a Quimax monitor. The Tandon is not the slickest, fastest AT out there—it runs only at 6 or 8 megahertz—but I needed a stock machine for evaluating software in a clean environment. The "40" in the name indicates that this baby comes with a 40-megabyte, 40-millisecond hard disk drive.

So far, it has run like a dream, right out of the box. Nary a problem. The monitor is a little fuzzy, and it broadcasts annoying interference to the Mac two feet away, but that isn't Tandon's fault. I'm pleased with the machine.

I'm pointing this out for two reasons. First, I'll be able to look at software that requires AT speed and EGA graphics (such as desktop-publishing products). Look for some AT/EGA packages to hit this column in the next few months. Second, my estimates of software speed will now be based on 80286 performance levels rather than the old 8088. Bear that in mind when you're reading about MS-DOS programs here; if I say a program is merely a little slow, you'll know it's absolutely impossible on an 8088 machine.

Name Change

Last October, I wrote about a neat shareware MS-DOS text database product called Instant Recall. It's a great little data-retrieval system: simple, fast, and uncluttered. You can store up to 2 megabytes of free-form text records, each of which can be up to 60 lines by 80 characters. There are no field names as such; you can search on any word or phrase that appears anywhere in the database. Because the program can operate either as a stand-alone application or as a pop-up with cut-and-paste capabilities, I've been using it to store all sorts of fragments, in-

cluding notes about appointments, stray electronic-mail messages, and reference materials for this column.

I've been waiting for an update for some time, but nothing has happened. I suspect Michael Fremont, the program's creator, has been caught in the trap that catches many shareware authors: He's been too busy running a small business to spend much time improving the code.

The good news is that relief is in sight. By the time you read this, the product will have become a commercial offering from Broderbund, and Fremont will no longer have to worry about marketing and distribution. The program will be known as MemoryMate (a horrible name, but there's at least one other package on the market called Instant Recall, so a name change was inevitable), and it will sell for \$69.95.

The first release of MemoryMate will not be a major revision of the package. I've been told to expect a slightly different look to the program's menu and a method of shutting off the Control-key command triggers to avoid contention with keyboard macro programs, but not much else.

I'm hoping Fremont will finally have the freedom to work on enhancements; I'll report changes when they happen. In the meantime, though, I still recommend the basic product; it's a winner.

No Longer a Clone

When Mirror, an MS-DOS telecommunications package, entered the world, it did so as a copy of Crosstalk XVI. Sure, there were some enhancements, but Mirror was intended to appeal to those seeking a low-cost alternative to Crosstalk. It looked like Crosstalk, it acted like Crosstalk, and it read Crosstalk scripts.

As you would expect, there was a lawsuit. Mirror lost. Now we have Mirror II (SoftKlone, \$69.95), sporting a user interface that doesn't look anything like Crosstalk XVI. No more infringement. However, Mirror

II still reads Crosstalk script files, and the new interface causes hardly a moment's pause to anyone familiar with Crosstalk.

This is my favorite stand-alone communications program. It supports more protocols and emulates more terminals than I'll ever need. A "learn" mode automatically creates Crosstalk log-on scripts (a nifty technique—Mirror stuffs the last 10 characters received from the remote computer into a variable so it can tie your actions to the actual prompts). If you initiate a file transfer, you can lean on both Shift keys and send Mirror into the background and continue working in the foreground; I've noticed no performance degradation when I do this.

There's a built-in editor for creating scripts, mail messages, and so on. Command lines can be edited without retyping. You can monitor call progress if your modem supports the procedure. Mirror II can keep a time-stamped transaction log. And your old Crosstalk files can be run without modification.

I used Mirror for a year. I've been using Mirror II for a month. I have been, and still am, extremely happy with this package.

A Better Card File

Tracker (Adaptive, \$99) is the kind of software package that can best be termed a "no-brainer." Designed for businesspeople with little patience for intricate computer procedures, it's an MS-DOS

continued

Ezra Shapiro is a consulting editor for BYTE. Contact him at P.O. Box 146069, San Francisco, CA 94114. Because of the volume of mail he receives, Ezra, regretfully, cannot respond to each inquiry.

client/contact database from Australia that runs either as a memory-resident utility or as a stand-alone program. Nothing spectacular, but it's simple and handy for anyone who has to make a lot of phone calls.

The program presents you with a data-entry screen containing 15 predefined fields for name, address, telephone number, and so on. Though you can change the field names, you can't alter the length of the fields or the appearance of the screen. Perhaps the most useful items here are the three date fields, for first

contact, last contact, and next contact; one touch of a function key retrieves the records for all the calls you have to make today.

Tracker has two secondary windows for each record. The first lets you attach a list of up to 20 keywords; the second is a utilitarian editor for adding text notes. Notes are stored by date; you can have as many as you like, provided you enter no more than—ahem—64,000 lines per note per day. Records can be dredged up and reports printed, sorted on any field or the keywords. The program will dump out

text files delimited for mail merge into half a dozen of the most popular word processors. Tracker will also auto-dial your phone and print mailing labels.

Objections? In resident mode, Tracker is a glutton, gobbling more than 200K bytes of RAM, a total that puts it at the extreme fringe of acceptability. If you use large applications, Tracker is just too fat to use as a pop-up. My only other complaint is that the display is downright unattractive. I really don't need a half-inch logo to remind me of the program's name on every data screen.

The documentation is readable and thorough. Collectors of curiosities will appreciate the full-color photograph of an Australian aborigine on the disk itself.

Tracker is obviously limited, but it's functional. If you need exactly what it offers, I recommend it. If you need anything more flexible, try MemoryMate or the contact tracking systems that come as sample files with so many database managers these days.

Now here's a question: Do you call software from Australia "Down Underware," or is that something you buy from L. L. Bean to keep you warm in the winter?

Another Courseware Package

I suppose it's fate that just because I decided to write about Macintosh courseware-authoring systems last month, another product in that category arrived precisely a week after my deadline. Sigh. Oyster (Poseidon, \$79.95) is a straightforward development system for instructional materials.

While Oyster isn't as flexible as its more ambitious competitors, it is easy to learn and use. It produces self-contained files that can be run as independent applications, and it's roughly a quarter the price of either Course Builder or Guide. Oyster lacks administrative functions, so it's useless for testing, but it's quite effective for training and drilling.

The basic building block is the multiple-choice question. You create the question and responses with the built-in editor, then drag radio buttons (called "hot dots" by Oyster) into position on the screen. A student using the completed course clicks on a dot to indicate the answer. Oyster allows importation of graphics through the Clipboard and Scrapbook functions; dots can be placed on top of images, so you can develop picture questions.

Any response can be linked to another screen full of information or another question, so you can organize files in any order you like—branching, linear, or even circular. The program keeps track

continued

BE THE WORLDS FASTEST PROGRAMMER

WRITE A **RELATIONAL DATABASE APPLICATION** IN **TURBO PASCAL** IN **6 SECONDS** WITH:

SYSTEM BUILDER and **REPORT BUILDER**

SYSTEM BUILDER and **REPORT BUILDER** make for amazing savings in development time. Simply define the database application you want by giving the system your specifications and **SYSTEM BUILDER** will generate the appropriate **TURBO PASCAL** source code. This code is complete and ready to compile into a working application.

*****Thousands Sold in over 30 Countries*****

* Up to 16 data files and 256 indexes simultaneously open, automatically maintained indexes. * Full screen painting with control over colors, ASCII characters, copying, pasting, etc. * Automatic maintenance of relational links, true mother-daughter operation. * Flexible! Link your own code. * Multiple selection criteria in reports, multiple control breaks, up to 16 files per report, range screens.

SYSTEM BUILDER 149.95
REPORT BUILDER 129.95

To Order or for More Information Call:

1-800-654-7766

In California: (800)851-2555
Or : (916) 920-2412

ROYAL AMERICAN
Technologies Corporation™

Cash, Check, VISA,
MASTERCARD or AMEX
accepted
320 HARRIS AVE. STE. A
SACRAMENTO CA 95838

CAREER ASSURANCE.

Dow Jones News/Retrieval® Membership gives you instant online access to:

Breaking Business News
The Wall Street Journal
The Washington Post
Updates On Competition
Investment Analysts' Reports
Detailed Corporate Profiles
Financial Overviews
P/E Ratios

Current Stock Quotes
Historic Stock Quotes
Company vs. Industry Performance
Instant "Backgrounder" Research
10-K & 10-Q Data
SEC Insider Trading Activity
Earnings Reports and Forecasts
An Online Business Library

... Just a sample of the many business and financial services available.

How to entrench your present position and promote your future success—for only \$49.95.

Can a \$49.95 membership in Dow Jones News/Retrieval®—the premier online business and financial information service from Dow Jones & Company, Inc.—really help assure you a more successful career?

Judge for yourself.

Mail the Membership Enrollment Form at right. Within a few days your Membership Kit will arrive and you can go online, analyzing breaking news from a continuously updated business journal—before it hits the newsstand.

You'll also have instant access to leading investment analysts' comments on your business hunches and strategies, plus the ability to get detailed reports on nearly 10,000 companies within minutes.

And those are only three of our 40-plus services.

Look over the others when you go online.

To start your membership, fill out the Enrollment Form at right, drop it in the mail and give our service a try.

After all, making sure you have more current, more complete information is a very assuring career move.

Membership Enrollment Form

Show me how Dow Jones News/Retrieval® can help assure my career success.

Send me a Corporate Membership Kit, entitling me to 8 free hours* of online time, passwords for myself and my colleagues, a User's Guide, 12 months of *Dowline™* Magazine, and waiver of my first year's \$12 annual service fee—for \$49.95.

Send me a Personal Membership Kit: same as above but with 5 free hours* of online time and a single password for myself alone—for \$29.95.

Check enclosed

Charge to my: AmEx MC VISA Bill me later

Card No. _____ Exp. _____

Signature (required) _____

If you pay by credit card, all future charges will be billed to that account.

Name _____ Title _____

Company _____

Address _____

City/State/Zip _____

Daytime Phone _____

Computer make and model _____

Please send more information.

Mail to: DJNR Membership Kit, P.O. Box 186
Drexel Hill, PA 19026-9973

For faster service,

call 1-800-221-7700, Ext. 4181 today!

Dow Jones News/Retrieval®

The premier source of online business and financial information.

4181

*Per account. New domestic and Canadian subscribers only. Free time must be used within 30 days after receipt of password(s). Some additional fees apply on certain services.
© 1987 Dow Jones & Company, Inc. All rights reserved.

1	Exxon
2	General Motors
3	Mobil
4	Ford Motor
5	IBM
6	Texaco
7	E.I. du Pont
8	Standard Oil (Ind.)
9	Standard Oil of Cal.
10	General Electric
11	Gulf Oil
12	Atlantic Richfield
13	Shell Oil
14	Occidental Petroleum
15	U.S. Steel
16	Phillips Petroleum
17	Sun

27 million Americans can't read. And guess who pays the price.

Every year, functional illiteracy costs American business billions.

But your company can fight back...by joining your local community's fight against illiteracy. Call the Coalition for Literacy at toll-free **1-800-228-8813** and find out how.

You may find it's the greatest cost-saving measure your company has ever taken.

A literate America is a good investment.



of the structure with an outline, much like a table of contents, that appears in a window in the lower portion of the editing display.

The documentation is superb. It's well-written and logical, and it contains one of the best discussions on how to develop successful computerized training programs that I've ever seen.

Oyster is a solid package, fairly priced, and good at what it's supposed to do.

A Direct Port

The MS-DOS version of Guide (OWL International, \$199.95) is a mirror image of Guide on the Macintosh, running under Microsoft Windows. I've already written extensively about Guide in my April and August columns, so I won't go into much detail here. It's a hypertext system; sliding the cursor over a section of text or a graphics image will pop open a new layer of information. You can organize material in surprising ways because you're freed from the linear constriction of either flat text or outline format. I like the concept, and Guide is an excellent implementation of it.

Once again, though, I'm dismayed at the clunkiness of the Windows interface as opposed to that of the Mac. First, you'd better have a PC AT to run the program at acceptable speed. Second, the text characters are rather ugly, even with an EGA setup. Third, Guide changes the shape of the cursor to indicate hidden layers within a document. This works fine on the Mac, but the special cursors in Windows seem huge and misshapen; moving through a Guide document is rather like dialing a telephone with a baseball bat.

Guide itself runs fine, but I was disappointed at the lack of color, which seemed a natural addition to an MS-DOS version. The sample files included are quite helpful, and the documentation is excellent.

Beggars Can't Be Choosers Department: For reasons I can't fathom, Guide on the PC costs \$65 more than the same product on the Macintosh. What can I say? Go buy a Mac?

Funnies Program

Now that Mindscape's ComicWorks has grown up into GraphicWorks, a powerful artistic tool, I could argue that the world once again has room for a Macintosh program designed exclusively for the creation of comic books. However, after playing with The Comic Strip Factory (Foundation, \$89.95), I'm not so sure.

What we have here is a comic strip assembly program. To call it a graphics package would be a mistake; though there are a few features you might find in painting and drawing software, The Comic Strip Factory (TCSF) has little capacity for the creation of original graphics.

You start with a blank page, on which you lay out borders for comic strip boxes. Next, you paste in backgrounds. Then you add characters, or rather you build them from a storage file of MacPaint body parts. You move a torso into position, then you graft on the appropriate head and limbs. Finally, you add speech balloons. What this is, really, is an object-oriented toolkit for constructing comics from graphic elements. If you will, The Comic Strip Factory is a Page-Maker for the funny papers.

continued

Items Discussed

Guide	Oyster	\$79.95
MS-DOS	Poseidon Inc.	
Macintosh	14 Quail Hollow Rd.	
OWL International Inc.	North Falmouth, MA 02574	
14218 Northeast 21st St.	(617) 540-9530	
Bellevue, WA 98007		
(206) 747-3203	The Comic Strip	
MemoryMate	Factory	\$89.95
\$69.95	Foundation Publishing	
Broderbund Software Inc.	10301 Yellow Circle Dr.	
17 Paul Dr.	Minneapolis, MN 55343	
San Rafael, CA 94903	(612) 935-4230	
(415) 492-3200	Tracker	\$99
Mirror II	Adaptive (USA) Inc.	
\$69.95	3701 Birch St.	
SoftKlone Distributing Corp.	Newport Beach, CA 92660	
1210 East Park Ave.	(800) 543-4329	
Tallahassee, FL 32301		
(904) 878-8564		

Announcing

Two Dynamic New Imprints

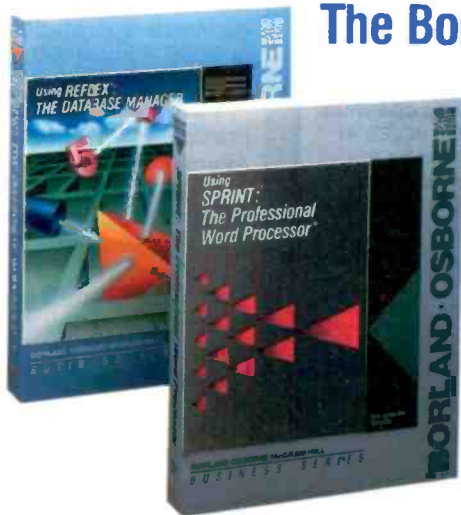

The Borland-Osborne/McGraw-Hill Business Series

- ◀ **Using REFLEX®: THE DATABASE MANAGER**
by Stephen Cobb
Features sophisticated SuperKey® macros and REFLEX Workshop™ applications.
\$21.95 paperback, ISBN 0-07-881287-9
- ◀ **Using SPRINT™: The Professional Word Processor**
by Kris Jamsa and Gary Boy
Take advantage of this fabulous new word processing system that is powerful, fast, and includes many desktop publishing features.
\$21.95 paperback, ISBN 0-07-881291-7

The Borland-Osborne/McGraw-Hill Programming Series



- ◀ **Using Turbo C®**
by Herbert Schildt
Here's the official book on Borland's tremendous new language development system for C programmers.
\$19.95 paperback, ISBN 0-07-881279-8
- ◀ **Advanced Turbo C®**
by Herbert Schildt
For power programmers. Puts the amazing compilation speed of Turbo C® into action.
\$22.95 paperback, ISBN 0-07-881280-1
- ◀ **Advanced Turbo Prolog® Version 1.1**
by Herbert Schildt
Now Includes the Turbo Prolog Toolbox™ with examples of spreadsheets, databases, and other business applications.
\$21.95 paperback, ISBN 0-07-881285-2
- ◀ **Turbo Pascal® Programmer's Library**
by Kris Jamsa and Steven Nameroff
Revised to cover Borland's Turbo Numerical Methods Toolbox™
\$21.95 paperback, ISBN 0-07-881286-0
- ◀ **Using Turbo Pascal®**
by Steve Wood
Featuring MS-DOS programs, memory resident applications, in-line code, interrupts, and DOS functions
\$19.95 paperback, ISBN 0-07-881284-4
- ◀ **Advanced Turbo Pascal®**
by Herbert Schildt
Expanded to include Borland's Turbo Pascal Database Toolbox® and Turbo Pascal Graphix Toolbox®
\$21.95 paperback, ISBN 0-07-881283-6



Osborne McGraw-Hill
2600 Tenth Street
Berkeley, California 94710

Inquiry 210

Available at Book Stores and Computer Stores.
OR CALL TOLL-FREE 800-227-0900
800-772-2531 (In California)

In Canada, contact McGraw-Hill Ryerson, Ltd. Phone 416-293-1911

Trademarks: SuperKey, REFLEX, Turbo BASIC, Turbo C, Turbo Pascal Database Toolbox, Turbo Pascal Graphix Toolbox, Turbo Pascal, Turbo Prolog, and Turbo Prolog Toolbox are registered trademarks of Borland International. REFLEX Workshop, SPRINT, and Turbo Pascal Numerical Methods Toolbox are trademarks of Borland International. WordPerfect is a registered trademark of WordPerfect Corp. WordStar is a registered trademark of MicroPro Int'l Corp. Copyright © 1987 McGraw-Hill, Inc.

McGraw-Hill
BORLAND-OSBORNE

IEEE-488

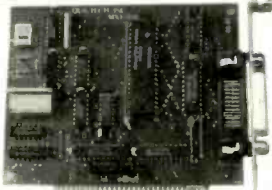

MXI-100

- GPIB controller board for IBM PC/XT/AT
- Control up to 14 Devices
- User friendly Software Commands
- DMA Transfer to 200k byte/sec.

QUA TECH, INC.

\$345.00 including software

478 E. Exchange St. Akron, OH 44304
(216) 434-3154 TLX: 5101012726

Inquiry 239

RS-422/232 CURRENT LOOP



DS-225

- Single channel async communication board for IBM PC/XT/AT
- Software selectable to be RS/422/485, 232 or Current Loop
- Selectable Address & Interrupt

QUA TECH, INC.

478 E. Exchange St. Akron, OH 44304
(216) 434-3154 TLX: 5101012726

Inquiry 240

RS-422 Communications Board

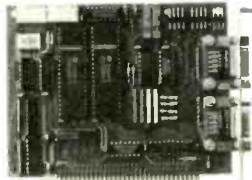

- For IBM-PC/AT/XT and compatibles
- Dual RS-422/RS-485 interface
- Differential drivers to 4000 ft.

Fast Delivery

QUA TECH, INC.

478 E. Exchange St. Akron OH 44304
(216) 434-3154 TLX: 5101012726

Inquiry 241

WAVEFORM SYNTHESIZER

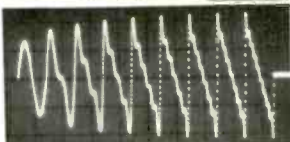

- For IBM-PC/XT/AT and compatibles
- Generates user-definable signal
- Up to 2000 points per envelope

QUA TECH, INC.

\$795.00

478 E. Exchange St. Akron OH 44304
(216) 434-3154 TLX: 5101012726

Inquiry 242

MODULAR DATA ACQUISITION



- For IBM & Compatibles
- Flexible and Inexpensive
- Money Back Guarantee
- Free Technical Support

Fast Delivery

QUA TECH, INC.

478 E. Exchange St. Akron OH 44304
(216) 434-3154 TLX: 5101012726

Inquiry 243

RS-232 Communications Board

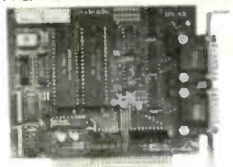

- For IBM-PC/XT/AT & comp.
- Dual RS-232C interface
- Optional software supports COM1, COM2, COM3, COM4
- Jumper selectable Interrupts

Fast Delivery

QUA TECH, INC.

478 E. Exchange St. Akron OH 44304
(216) 434-3154 TLX: 5101012726

Inquiry 244

The program is clear, simple to run, and its operations are all handled smoothly. You've got a pixel editor (similar to FatBits) for refining images and a separate utility called PartMaker for collecting objects from MacPaint files to be used in TCSF. I found no real bugs or anomalies when I built a few strips of my own.

The only problem I encountered was in printing, and that had more to do with the nature of laser printers than with TCSF. The Comic Strip Factory is really best at ImageWriter printing. When I forgot to disable smoothing, the poor QMS laser printer took forever to calculate the transition from 72 to 300 dots per inch. Printing was positively painful.

TCSF comes with a collection of six characters (actually a collection of their body parts) that you can combine into a comic strip. You get a moth-eaten wizard, a fantasy lizard with big teeth, a computer nerd with thick glasses (destined to offend anyone who's ever spent time with a computer), an elfin dancer with breasts and tiger stripes, and two cutesy insects. The insects are named, so help me, Broadway Bug and Sweet Patootie. It's easy enough to tell them apart—the male has a top hat; the female has eyelashes and a brassiere. Drawn by Trici Venola, they're proof that the Macintosh can be used to produce glib, trite comic art.

The four backgrounds provided with TCSF, by Kurt Wahlner, are much more neutral, and hence better. I admit that this is a judgment call, but if you've got any imagination, creativity, or self-pride, you won't want to use this stuff.

If you want to be original, you're going to have to use MacPaint to create your artwork, then chop it up with PartMaker so it can be digested by TCSF. In order to create a comic strip, you're going to be using three programs. Both SuperPaint and GraphicWorks are supersets of MacPaint, and not much tougher to learn. And those programs give you object orientation and rotation, as does TCSF, but you also get a full palette of graphics tools, editing at laser-printer resolution, and a host of other features lacking in TCSF. With a teeny bit more effort, you can create comics entirely within either program.

The Comic Strip Factory is fun to use, and it's well-documented. Its creators seem to be neat people. I wish I could justify the purchase of it for those reasons alone, but I can't. This is a limited graphics environment for the assembly of comic strips, priced roughly equivalent to superior graphics programs that can do everything that TCSF does and more. The Comic Strip Factory is just too little too late. ■

Choose ALR's 16-MHz 80386 system for less than \$2,000, or a blazing 20-MHz system for less than \$2,500.



Last year, Advanced Logic Research introduced the first 80386 systems. Now we're introducing the ALR 386/2™, the second generation.

Until now, if you wanted three times the speed of an AT™ you paid about three times the price of an AT. Now Advanced Logic Research announces second-generation 386 systems—designed to do to the price barrier what our first generation did to the performance barrier. Annihilate it.

Starting at \$1990, ALR's totally new 386/2 systems couple the power of 32-bit processing with true 32-bit memory. Even the system and graphics BIOS are implemented in a 32-bit architecture. That simply means your applications will run faster on a 386/2 than any other available computer. And ALR 386/2 systems let you use all the peripherals, graphics, enhancements and applications developed for the most widely adopted computer operating environment in history.

Which makes you wonder why others want thousands more for less flexible, first-generation 386 systems.

How to run circles around the competition.

Sure, Compaq and IBM use the fastest available hard

- Advanced Logic Research
- Compaq
- IBM



disks and controllers with 1:1 interleaving, just like Advanced Logic Research. But they don't buffer a full 17-sector hard disk track, settling for sector by sector buffering. Our way makes the fastest even faster where it counts— in the real world.

And with up to 2 MB of RAM on the motherboard, you get flexibility with your power.

Naturally the raw speed of the 80386 means the 386/2 series make great EGA graphic workstations for CAD/CAM. Or choose enhanced EGA™ or GA 786™ graphics from ALR and a variety of sources and get the most advanced resolutions available.



You can even run applications without memory limitations. Because all enhanced ALR systems include the Phoenix Control/386 Software utilities with 32 bit disk caching, Vdisk and EMS/EEMS Software.



The 386/2 series makes the best use of floor or desk space.

Speed to burn. Without having money to burn.

Read the reviews and compare the 386/2 to the others. Then compare more. If you find more power, flexibility and quality somewhere else, buy somewhere else.

You won't find a more competitive price anywhere else—the ALR 386/2 Model 10 delivers 80386 power and 1 MB of RAM for \$1990 and includes a 1.2 MB floppy disk drive and controller. Models with hard disk storage to 130 MB and included Control/386 software reaffirm ALR's ability to define leading edge performance. At leading edge prices.

A full range of high-performance communications, memory and storage enhancements are available from ALR.

- Advanced Logic Research \$4389
- IBM \$6995
- Compaq \$7094

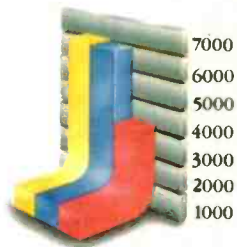

The ALR 386/2 Model 40 with EGA adapter is similar to the IBM Model 80-041 and Compaq Deskpro 386 Model 40 with EGA adapter. Except for a lower price and twice their standard RAM.

Advanced Logic Research. Faster, first.

Advanced Logic Research got its start designing high-performance microcomputers for customers that demanded more power than they could get off the shelf. We designed one of the first IBM PC-compatibles. Developed the enhanced performance AT-compatible *PC Magazine* called "... the most judicious choice..." And introduced the first 386 system, which *PC Tech Journal* said "... brings up-to-date technology to affordable 386 systems."

FREE
20-MHz OPTION
ON 386/2 Model 130
systems until November 1

Call Advanced Logic Research today for the name of your local ALR dealer. And discover the price of power isn't as high as it used to be.



Advanced Logic Research, Inc.

10 Chrysler, Irvine, CA 92718 (714) 581-6770
FAX: (714) 581-9240 TELEX: 5106014525.
Answer back Advanced Logic
From Asia or Europe call ALR/Wearnes Technology
Phone: (65) 2592521 TELEX: RS38113WRNTEC

Inquiry 340 for End-Users.
Inquiry 341 for DEALERS ONLY.



**“BOOST YOUR
PRODUCTIVITY
WITH A
BUNDLE OF
FAST,
POWERFUL
SCREEN AND
KEYBOARD
UTILITIES!”**

- Speed up your screen writing 2-6 times!
- Add zip to cursor keys 2-5 times!
- Get back up to 800 scrolled pages!
- Save valuable scrolled info to disk
- Free your eyes from scroll blinking
- No more annoying typeahead beep
- Prevent screen phosphor burnin
- Shorten that annoying bell
- Get 43 line EGA support
- Extend your ANSI.SYS to VT100
- Add many more escape sequences
- Over 60 useful options!
- Easy installation
- Works well w/ thousands of programs
- Used by thousands since 1984!

“The Best of the Best Utilities”
—PC Magazine Jun 23, 87 pg 281.

*“The implementation of all the services
are at least as good in Fansi-Console as
in any competitor”*
—Capital PC Monitor May 86 pg 25.

*“Another of those unheralded gems
I would not wish to live without”*
*“Clear, readable, highly professional
manual, excellently typeset”*
—Computing Canada Feb 5, 87 pg 25.

**ANSI-™
CONSOLE**

The Integrated Console Utility™

Pay Less and Get More!

ONLY \$75!

(plus \$4 s/h in 48 states)

400p Manual (w/slip case)
and 2 Copyable Disks

With No Risk, 60 Day Money-Back
Satisfaction Guarantee

CALL (313) 994-3259 NOW
to order with Visa/MC/AmEx

HERSEY MICRO CONSULTING, INC.
Box 8276, Ann Arbor, MI 48107

Circle 122 On Reader Service Card
To Get FREE Brochure w/Reprints
DEALER INQUIRIES INVITED

continued from page 32

“sleep”: You put a request to the system for a keypunch and then gracefully get out of the way of the CPU so other tasks can have more time. If you busy-wait, you hog the CPU and prevent some other tasks from running.

Another rule to follow is to go through the operating system for almost any procedure. Once programs start viewing the operating system as the resource manager, they are freed from the task of determining the exact configuration of the particular machine they are running on. Sure, there is an overhead for multitasking and for having to consult the operating system for resources. But the overall gain in productivity is a more important factor.

Programs written for the earlier 8-bit micros, and even for the IBM PCs, are for the most part assembly language hacks that attempt to get the most out of every byte and every microsecond. Thus, they tend to pay little attention to the operating system. In the 8-bit 1-MHz world, this sort of programming is acceptable. In the 16- or 32-bit 8-MHz world, it is not.

Unfortunately, the Atari ST has the body of a 16-bit computer but the mind of an 8-bit computer. As a result, the primitive and inflexible software practices for the Atari ST remain in the dark ages—even if it is easier to port to the ST than to the Amiga.

Ali Ozer
Stanford, CA

I suppose you're right. The fact is, though, that while I see very elegant stuff for the Amiga, I see five times as much software developed for the Atari ST.

Every now and then, too, I get a finished program that, when put in the Amiga, gives me a guru meditation. I've given up copying that long-number error message.

But it's a gorgeous machine, and I have no doubt you're right about its versatility.—Jerry

Dear Jerry,

Concerning the letter from Warren Block in the March Chaos Manor Mail and your subsequent response, I am inclined to think that both of you are, in fact, correct and that there should be no argument.

Version 1.1 of the Amiga's operating system is prone to the “quest for the guru,” and there is also a lot of irresponsible software out there in Amigaland. The reason for the slop in the available software may be partly due to the following problems: The Addison-Wesley manuals are fraught with ambiguities, errors,

and missing explanations; there is very little support for assembly language programming in comparison with the voluminous C support; and only low-level programming can keep a fairly firm grip on the reins of the operating system (yes, I know C is a systems language, but try writing interrupt code with it, or perhaps time-critical disk code).

Version 1.2 is more stable. Available software is rarely able to run correctly on both versions, however, and I find myself cataloging my software according to this phenomenon. Also, RAM expansions don't seem to be supported very well (if at all).

I think the Amiga is an excellent piece of hardware. But when it comes to software—both systems and applications—it fails the test. A multitasking system is fine for use within an application, but on a system of this size with so few physical devices (not to mention the fact that any application can usurp the system), I really don't see the point.

Most likely it will take a few more years before the Amiga is truly understood. When this happens, we may well see the appearance of some very phenomenal software. Until then we will just have to settle for being both amazed and disgruntled at the same time.

Michael N. McFarland
Little Rock, CA

Close to my own sentiments. Thanks.
—Jerry

Disk Could Be a Problem

Dear Jerry,

In the March Chaos Manor Mail, you stated in reply to Paul Horvick that “most of that stuff is on such cheap media that I won't even put them in my machine for fear it will mar the disk heads.” How can we identify disks that are likely to damage disk heads? Do some disks contain abrasive materials that cause this problem? As cheap disks are flooding the market now, I would appreciate some comments on how to select disks.

Harry H. Hull
Sun City Center, FL

In the old CP/M days, there were certainly disk brands I wouldn't put in my drives. I more than once found marks on the disk heads that mucked up both read and write operations. In those days I pretty well knew the cheap brands.

Now, I don't; but I do know the good brands, like Dysan, Scotch, and Maxell.

I'm probably too paranoid, but if a disk looks at all questionable—marks on the media, lack of high polish, etc.—I'll run it once, but only to copy what's on it.—Jerry ■

You don't have to be an Engineer to use CAD anymore!

We've made Computer Aided Design & Drafting so easy-to-use, affordable, and capable that now it's showing up virtually everywhere. In the office, on the job site, at school, and home.

Managers are using Generic CADD™ to generate reports, forms and flow charts. Tradespeople are using Generic CADD™ to make plans and change plans. Schools are using Generic CADD™ to change the way their students learn.

Professionals of all types now realize that Generic CADD™ gives the same kind of power over their drawing that spreadsheet programs gave them with numbers!

Generic CADD™ Just \$99.95
Not copy protected.
60-day money back guarantee.

Productivity Modules:
DotPlot™
AutoDimensioning™
Drafting
Enhancements 1™ & 2™
AutoConvert™
Generic IGES™



To order, call toll free:
1-800-228-3601
or 206-885-5307
8763 148th N.E.
Redmond, WA 98052

Inquiry 106 for End-Users.
Inquiry 107 for DEALERS ONLY.

Generic
SOFTWARE





Personal System/2
CAD/CAM
Desktop Publishing

Hands-on Classes
Show Specials
and Bargains
Vendor
Presentations

The 10th Northeast Computer Faire shows you how to get from Beantown to Boomtown.

With this year's special focus on the biggest vertical markets in Boston and throughout New England, the Northeast Computer Faire maps out the way to bigger business opportunities and higher productivity.

Highways to Success

Our Conference and exhibit floor will highlight computer products geared to fit your business needs in areas such as manufacturing, education, engineering, medicine and finance. And we'll be spotlighting software for CAD/CAM, Desktop Publishing, Communications, Business and Accounting.

Seminars Put You in The Passing Lane

In our exclusive Professional Development Seminars, top instructors will guide you through timely subjects such as IBM's Personal System/2, desktop publishing, and advanced programming techniques for dBASE III Plus.

The Freeway to Expertise

In our free hands-on classes, you can test drive desktop publishing systems, Lotus 1-2-3, MS-DOS, MultiMate and Wordstar.

Plus, vendor presentation sessions offer you in-depth new product introductions. Special demonstrations will feature exciting explorations into the world of computerized music, animation, video and other areas. And more show specials and bargains on products and services will be available than ever before. Get started on the road to Boomtown now by filling out and sending in the discount registration form below!

Or register on-line with Boston CitiNet. Dial (617) 439-5699 on your modem and enter GO FAIRE, or call (617) 439-5678, today!

THE 10TH NORTHEAST COMPUTER FAIRE

October 15-17, 1987 • World Trade Center, Boston
TO EXHIBIT CALL (617) 449-6600, EXT. 5077.

Inquiry 346

* IBM Personal System/2 is a registered trademark of International Business Machines Corporation. † Lotus 1-2-3 is a registered trademark of Lotus Development Corporation. ‡ MS-DOS is a registered trademark of Microsoft Corporation. § MultiMate is a registered trademark of MultiMate International Corporation. ¶ WordStar is a registered trademark of MicroPro International Corporation. dBASE III Plus is a trademark of Ashton-Tate Corporation.

ADVANCE
REGISTRATION
Beat Rush Hour
and save \$5.00!

Please send me more information about professional development seminars.

Name _____ Title _____

Company _____

Address _____

City _____ State _____ Zip _____

Phone (_____) _____

Advance registrations accepted only with full payment and each registrant's name and address. Tickets will be mailed to each individual separately. Fill out and send in this form with your check(s) postmarked by 10/01/87. Please photocopy to provide names and addresses of all registrants for whom you are enclosing a check.

Three day conference and exhibits \$10.00 in advance, \$15.00 at the door. Make check payable to "The Northeast Computer Faire." Mail to: Attendee Registration Department, The Northeast Computer Faire, The Interface Group, Inc., 300 First Avenue, Needham, MA 02194. BY987

The Best of BIX is a small sample of the type of one-on-one interaction that users of the BYTE Information Exchange enjoy regularly. If you'd like to take part, see the advertisement on page 285.	Apple	317
	Macintosh.....	318
	IBM PC	324

APPLE

The Apple section this month consists entirely of a long message from conference comoderator Morgan Davis about the results of his investigation into the virtually undocumented IIGS serial ports.

THE IIGS SERIAL PORT PROCESSOR: AN INVESTIGATION

apple/source #50, from mdavis (Morgan Davis, conference comoderator), Tue May 12 16:23:35 1987.

I've come to the conclusion that if one requires information about how to access certain features of the Apple IIGS, the one is left to one's investigative devices. This has been traditional for as long as I can remember, anyway.

With the emergence of the IIGS we were supposed to see a plethora of technical information being made available to anyone who could pay for it. Addison-Wesley is publishing the huge technical volumes on the IIGS's Toolbox, as well as a "suite" of other IIGS technical manuals. And anyone can walk down to the bookstore and pick up a copy.

One area where nobody seems to know what is going on is with the IIGS's serial port. Those of you who have had BIX accounts for at least eight months have seen many pleas for information about the ports, but so far, none of our knights in shining phosphor from Apple have been able to provide much assistance.

CAP ON, MAGNIFYING GLASS IN HAND

Being generally curious, finding out what the deal is with the ports has become more of an adventure for me than a real need. To start my investigation, I obtained a large "Components Data Book" for Zilog chips. As we all know, the two Apple IIGS ports are governed by a single Zilog 8530 serial communications controller (SCC) chip. From this, I've learned that the SCC in the IIGS is a very powerful and exciting chip to work with.

Without getting into the heavy technical descriptions of the features of this chip, let's just say that it does a lot of fancy stuff that the old 6551, used by the IIC and the Super Serial Card, never could have accomplished.

The 8530 has two channels, one for the printer port and the other for the modem port. They are labeled "Channel A" and "Channel B." In the peripheral I/O area of the IIGS (\$EOCCxx) are four locations that allow a program to directly access the 8530. They are:

- C038 - Channel B control and status register
- C039 - Channel A control and status register
- C03A - Channel B data register
- C03B - Channel A data register

For programmers, this arrangement makes it easy to access the register for the channel you require by using an indexed instruction. What's slick about this dual-channel system is that the same location can be used to obtain status information (by reading), or to control certain SCC modes (by writing). For passing data in and out of the SCC, you either read the data register to grab a character, or you write to the data register to send one out. Overall, a simple scheme.

Here's where it gets messy.

REGISTERS FOR DAYS

Unknown to most is that the 8530 has many internal 8-bit registers that correspond to a variety of functions and statuses. In all, the chip has nine read registers and 16 write registers!

Of the nine read registers, only four of them can actually be used for reading status information: RRO, RR1, RR10, and RR15. Read Register #8 (RR8) is the same as the associated channel's data register (\$C08A or \$C08B).

All the 16 write registers (WRO through WR15) can be accessed, and, like RR8, Write Register #8 is the data register, used for sending a character out of the port.

Some of you might wonder how one would access up to 16 independent registers on the 8530 when we're given just one location per channel in which to access the chip. This is done by selecting the register you want to work with. To select a register, you store the register's number (0 to 16) in the lower three bits of the appropriate channel's control register (either \$C038 or \$C039). The next time you access one of those two locations, you'll be accessing the 8530 register you specified by the initial write.

So, in order to read a certain register, it would require one write to select it, and then the read. Conversely, to write to a specific register, you must write once to select it, and then write again to make your change. As an example, the following will read RR12 from the monitor:

```
*c038:0c    ;Select register 12, Channel B
*c038
[RETURN]    ;Read RR12's value
```

One important note needs to be made. If you select, for example, Register #2 and then read \$C038 (Channel B status) twice in a row, you'll get two different values. This is because the 8530 will reset the selected register back to Register #0 (RRO or WRO) after you've either read or written to your selection. You'd read RR2 the first time, and then read RRO the second time.

(By the way, register selection is made by writing to WRO. If you're not sure if WRO is selected when you first want to access the 8530, you should read the status register first so that the 8530 will reset the register selection to #0 for you. This isn't written down anywhere, but I think it would be a safe thing to do).

HIGH LEVEL, HIGH ADVENTURE

For those of you who don't enjoy having to get down on your hands and knees to access the bare hardware, relax in knowing that you can talk to the 8530 through the serial port firmware on the Apple IIGS. You'll have to make extended calls to the firmware using GetSCC and SetSCC to reach the many registers of the 8530, but at least it keeps your clothes clean.

continued

As an example, the following routine, which can be typed into the monitor, will read RR12 (the low byte of the data-rate time constant).

```
]call-151      ;Enter the monitor
*!             ;Enter mini-assembler
!300: lda #80  ;A, X, and Y to point to parameters
! ldx #03      ;(the address is $00/0380)
! ldy #00
! jsr c214     ;Pascal 1.1 extended-call entry point
! rts
! [RETURN]    ;Exit mini-assembler
*380:04       ;Parameter count is 4
*381:08       ;Extended code is 8 = GetSCC
*382:00 00    ;Result space
*384:0c       ;Oc = RR12
*385:00       ;Value from RR12 is returned here
*300G         ;Call our routine at 300
*385 [RETURN] ;View contents of RR12
```

This shows how to make an extended call to the Pascal 1.1 firmware for slot 2 (usually the modem port). It's hardcoded to \$C214, but you should look at the byte at \$C212 to find the low-byte offset into \$C200 for the extended-call entry point.

WRANGLING WREGISTERS

By now, you're probably wondering what each of the read and write registers do, and which bits control what. Sorry, I'm not going to type in the settings for 200 bits. If you're really interested in this stuff, I strongly recommend that you order a data sheet from Zilog or pick up a components manual. Why the spec sheet for the 8530 was not included with all the other data sheets in the Apple IIGS Hardware Reference is beyond me. Then again, there are many things Apple does that are beyond the grasp of rational comprehension. :-)

If interest is high, perhaps I can type in descriptions of what I consider to be the few most useful registers. Until then, good luck with your own investigations, and I'll be sure to post any other pertinent information on this subject when I uncover more.

--Morgan ("Real Programmers Don't Need Manuals") Davis

MACINTOSH

Nobody's perfect, as shown by a BIXen's look at the typos inside a Macintosh SE. That discussion eases into a hot debate on the SE's cooling fan. There's a discussion on the apparent fragility of the SE, and a how-to on hooking up MultiSync/Multiscan monitors to the Macintosh II. And how compatible is the Mac II NuBus anyway?

THE GREAT MAC SE TYPO-AND-FAN SAGA

macintosh/mac.se #220, from bmg (Raines Cohen), Fri May 22 08:32:41 1987.

For the curious, while disassembling a Mac SE, I noticed the following:

- >> The analog card is labeled "MATINTOSH," with a T!
- >> The video card is marked "ALADDIN VIDEO CARD," and a wire label reads "ORANGE."
- >> There is a spot for a resistor just below the fan. Perhaps to slow and quiet it down?

macintosh/mac.se #221, from lloeb (Larry Loeb, conference moderator), Fri May 22 10:06:49 1987. A comment to message 220.

The Billy Steinberg solution for the fan:

"100 ohms at 1/2 watt."

macintosh/mac.se #225, from nz__mhamel (Michael Hamel), Sun May 24 00:44:23 1987. A comment to message 221.

Speaking of the fan, surely some thoughtful hardware person (coughing violently and pointing to self) could, if they had an SE (more coughing), make the fan thermostatically controlled. I mean, it must be designed to cool a fully loaded SE with hard disk, external drive, and something in the slot at ambient temperatures of 35c or so. So most of the time it's running much too fast. A temperature sensor coupled to a proportioning control should ensure it only comes on when it has to and at whatever speed it has to to keep things cool. Probably it would just start to make enough noise to be annoying after you had worked at the SE long enough to be really irritated by it, eh?

macintosh/mac.se #226, from wbeck (Warren Beck), Sun May 24 01:51:11 1987. A comment to message 225.

On the fan, also, has anyone else noticed that when the hard disk in the SE is reading in a long file, such as an application, that the speed of the fan changes. I mean to say, the pitch of the whine goes lower transiently and then returns to its normal continuous-wave whine. Does this mean that the power supply is being taxed such that the voltage on the fan drops a little when the hard disk is turning? Sounds like the power supply is a little too close to the specifications for the hardware being powered. Which means that the fan is really needed to keep the SE from becoming a baked apple (which the Mac Plus I use at work has done twice), since a larger power supply was not used, apparently owing to heat constraints.

macintosh/mac.se #228, from lloeb, Sun May 24 08:33:48 1987. A comment to message 226.

I've had two review machines in here and BOTH fans never changed pitch under any load or disk operation.

The Sony power supply is 100 watts up from 60 watts on the "Classic" Mac.

I think there is AMPLE margin designed in this time; and would disagree with your thoughts on this.

macintosh/mac.se #230, from rsimonsen (Redmond Simonsen), Mon May 25 01:29:29 1987. A comment to message 228.

Could be a harmonic that is changing the sound of the fan rather than a slowdown due to stressing the power supply.

macintosh/mac.se #233, from bohannan (Bruce Bohannan), Fri May 29 23:56:54 1987. A comment to message 226.

I have the same problem (attribute?) with my SE fan. . . about once an hour, the pitch rises and then falls back to normal. It sounds like some sort of harmonic distortion to me.

macintosh/mac.se #229, from bvanantwerp (Bill Vanantwerp), Sun May 24 15:13:10 1987. A comment to message 225.

Trouble is that a true pid-type controller costs more than it's worth, I would think. My solution on a Plus was to install a

continued

SAY CHARGE IT!
AMERICAN SEMICONDUCTOR
CHARGE CARD



American Semiconductor

Gives you the prices and products that have quickly made them,



TOP GUN

Complete systems for Less than ANYBODY!
And we can FINANCE YOU!

Our revolving charge makes owning the system you want easy!
Over a \$BILLION of FINANCING AVAILABLE!!
NOT A LEASE ★ YOU OWN IT!

★ FREE!!
FLIGHT SIMULATOR LIMITED TIME OFFER!!
WITH ANY COMPUTER PURCHASE

\$29.^{mo.}

TURBO XT MODEL #5301

- Selectable 4.77 & 8 MHz Processing Speed • 640K RAM Memory • Bios • One 360K Floppy Drive • Floppy Controller w/Cable • Eight Expansion Slots • PC/XT Compatible Keyboard

RETAIL VALUE 1099.
OUR PRICE 499.

\$39.^{mo.}

TURBO XT MODEL #5302

- Selectable 4.77 & 8 MHz Processing Speed • 640K RAM Memory on Main Board • Bios • 16 Bit 8088-2 CPU • One 360K Floppy Drive • Multi I/O (w/Floppy Controller, Clock/Calendar, Parallel, Serial, & Game Port) • Eight Expansion Slots • PC/XT Compatible Keyboard

RETAIL VALUE 1699.
OUR PRICE 739.

\$45.^{mo.}

TURBO XT MODEL #5303

- Selectable 4.77 & 8 MHz Processing Speed • 640K RAM Memory on Main Board • Bios • 8088-2 CPU • One 360K Floppy Drive • Multi I/O (w/Floppy Controller, Clock/Calendar, Parallel, Serial, & Game Port) • Eight Expansion Slots • One 10MB Hard Drive (w/Controller) • PC/XT Compatible Keyboard

RETAIL VALUE 1999.
OUR PRICE 1019.

\$49.^{mo.}

TURBO XT MODEL #5304

- 8 MHz Processing Speed • 640K RAM Memory on Main Board • Bios • 16 Bit 8088-2 CPU • Two 360K Half-Height Floppy Drives • Multi I/O (w/Floppy Controller, Clock/Calendar, Parallel, Serial, & Game Port) • One 20MB Hard Drive (w/Controller) • TURBO/Normal Mode Either Software or Hardware Selectable • Eight Expansion Slots • PC/XT Compatible Keyboard

RETAIL VALUE 2499.
OUR PRICE 1295.

\$49.^{mo.}

TURBO XT MODEL #5305

- 8 MHz Clock Speed • 640K RAM Memory on Main Board • Bios • 16 Bit 8088-2 CPU • Two 360K Half-Height Floppy Drives • Multi I/O (w/Floppy Controller, Clock/Calendar, Parallel, Serial, & Game Port) • 30MB Hard Drive (w/Controller) • TURBO/Normal Mode Either Software or Hardware Selectable • Eight Expansion Slots • PC/XT Compatible Keyboard

RETAIL VALUE 2499.
OUR PRICE 1479.

\$59.^{mo.}

TURBO XT MODEL #5306

- 8 MHz Processing Speed • 640K RAM Memory on Main Board • Bios • 16 Bit 8088-2 CPU • Two 360K Half-Height Floppy Drives • Multi I/O (w/Floppy Controller, Clock/Calendar, Parallel, Serial, & Game Port) • 30MB Hard Drive (w/Controller) • TURBO/Normal Mode Either Software or Hardware Selectable • Eight Expansion Slots • PC/XT Compatible Keyboard • IBM Compatible Enhanced Graphics Adapter (EGA) • High Resolution EGA Monitor

RETAIL VALUE 3899.
OUR PRICE 1949.

\$5.^{mo.}

VIDEO GRAPHIC PACKAGES

MONOCHROME COLOR EGA ENHANCED
WITH MOST SYSTEM PURCHASES

HARD DRIVE KITS from 10 mb. to 360 mb.

\$69.^{mo.}

TURBO AT MODEL #5503

- 10 MHz Clock Speed • 812K RAM Memory (1MB Option Available) • Bios • Intel 80286 Microprocessor • 1.2MB Half-Height Floppy Drive • 40MB Hard Drive (w/Controller) • Eight Expansion Slots • Serial/Parallel Adapter • AT Compatible Keyboard • Performance 16, 12, 10, 8, 6 MHz Available

RETAIL VALUE 2999.
OUR PRICE 2099.

\$59.^{mo.}

BABY AT TURBO MODEL #5507

- 8-10 MHz Processing Speed • 8 MHz • 640K (Expandable to 1MB on Main Board) • Bios • 80286 Based CPU • 360K Half-Height Floppy Drive • Hard Drive (w/Controller) • Multi I/O (w/Floppy Controller, Clock/Calendar, Parallel, Serial, & Game Port) • 20 MB Hard Drive (w/Controller) • AT Style Keyboard

RETAIL VALUE 3099.
OUR PRICE 1759.

\$59.^{mo.}

TURBO AT MODEL #5501

- 812K RAM Memory (Expandable to 1MB on Main Board) • 80286 Based CPU • Bios • 1.2MB Half-Height Floppy Drive • 20MB Hard Drive (w/Controller) • Eight Expansion Slots • Parallel Adapter • AT Style Keyboard • Performance 16, 12, 10, 8, 6 MHz Available

RETAIL VALUE 3099.
OUR PRICE 1719.

\$69.^{mo.}

TURBO AT MODEL #5502

- 10 MHz Clock Speed • 812K RAM Memory (1MB Option Available) • Bios • Intel 80286 Microprocessor • 1.2MB Half-Height Floppy Drive • 30MB Hard Drive (w/Controller) • Eight Expansion Slots • Serial/Parallel Adapter • AT Compatible Keyboard • Performance 16, 12, 10, 8, 6 MHz Available

RETAIL VALUE 4499.
OUR PRICE 1959.

NEW 386

MODEL #5701

- 16 MHz Processor Speed • Intel 80386 Micro Processor • 32 Bit architecture • Compatible with 8 MHz 80286 Hardware & Software • Phoenix 386 Bios • Four Speed Selection (16, 8, 6, 4.77 MHz) • Relocation of Bios • EGA Bios to 32 Bit High Speed RAM for Lightning Execution • Real Time Clock • 4, 8 or 10 MHz 80287 Co-processor Socket • Standard 32 Bit High Speed Memory Board 1MB of RAM Memory Installed, Connectors For Attaching Up to 10MB of Memory • 1.2MB Half-Height Floppy Drive • Eight Expansion Slots • Serial/Parallel Adapter • AT Compatible Keyboard

RETAIL VALUE 8999.
OUR PRICE 3272.

\$59.^{mo.}

AT PORTABLE TURBO MODEL #5509

- XT 640 RAM Memory • AT 512 RAM Memory • 1/2 High 360 Floppy disk drive • 8088 CPU/80286 CPU • RAM 840K • Operating system, CP/MS-DOS & UCSD-P+ interface cards; multi 16 card, color graphics card or monochrome card • Dual frequency monitor or monochrome monitor • Pioneer 135W power supply (for XT) 200W power supply (for AT) • AT/XT detachable keyboard (Cherry Switch) • Size: 48 cm (H) x 44 cm (D) x 19 cm (W) • Weight: 14 kgs

RETAIL VALUE 2995.
OUR PRICE 1749.

INSTANT CREDIT NOW!
Even if you have a computer... We'll sell you add-ons from our **TOP QUALITY** products, and **FINANCE** them too!

CHEAPER PRICES? AMERICAN SEMICONDUCTOR had to make a choice between building our products as cheaply as possible and selling it as a 'get-by' product, or building quality into our products for service, durability and your long lasting enjoyment. We know you would prefer to deal with a company that puts every thing possible into its product, to make it the best. The best things are never the cheapest, and cheap things are seldom the best. NO OTHER COMPANY CAN OFFER YOU A 9 YEAR WARRANTY ON ITS XT & AT TURBO MOTHER BOARDS. AND INSTANT CREDIT BESIDE! *Our direct control, from R&D component selection to final assembly, enables us to maintain quality throughout the complete manufacturing process. THAT'S WHY WE SELL SO MANY!

President, American Semiconductor, Inc. *Anthony R. O'Neill*

MONITORS ARE ADDITIONAL. SURGE PROTECTOR/POWER DISTRIBUTION CENTERS ARE OPTIONAL AND AVAILABLE FOR ONLY \$39.95

3 YEAR CHARGE IT!
ADD 3.95%
ORDER TOLL FREE!
1-800-237-5758 EXT. 823
CUSTOMER SERVICE (813) 961-5584
IMPORT EXPORT
(813) 961-9444
OPEN MON - FRI 8 AM - 7 PM
OPEN SATURDAY 9 AM - 5 PM (EST)
CORPORATE HEADQUARTERS: 16520 N. FLORIDA AVE., LUTZ, FLORIDA 33549, (813) 961-9444

DEALERS! call for the up to minute prices for **DRAM'S, 3087's, EXPANSION CARDS, IC'S** and much, much more!

NORTHEAST REGIONAL SALES OFFICE 1-301-933-3523 WASHINGTON, D.C. AREA 1-800-942-9488

1-800-825-SAVE

OFFICES NOW OPEN: TAMPA - MIAMI - LOS ANGELES - WASHINGTON, D.C. - TAIPEI, TAIWAN - TOKYO, JAPAN
PRICES SUBJECT TO CHANGE DUE TO AVAILABILITY AND MARKET FLUCTUATIONS. VOID WHERE PROHIBITED. \$25.00 CREDIT APPLICATION FEE

fan with a switch that I turned on only when I wasn't within earshot. Works like a dream. Inside my Plus rarely gets to be more than 30c.

FRAGILE SE: HANDLE WITH CARE

macintosh/mac.se #235, from tom__thompson (Tom Thompson, BYTE), Mon Jun 8 08:47:03 1987.

Well, we just got our SE back from COMDEX, and it turns out that they don't take to being hauled about too well. Case in point:

A key on the keyboard was broken off. I managed to reattach it by *very* carefully using epoxy cement. One foul-up and the key could have been glued permanently into the "on" position, but with a lot of care and a little luck I managed it. This reaffirms my previous opinion about the new keyboard - a tad too frail for my liking, especially when compared to the classic Mac keyboard. (We've shipped some of these Macs to various shows, and I've yet to hear of a keyboard problem.)

The video display didn't work. This provoked a number of four-letter runic incantations, after which I switched the SE off. Turning it back on, I could see that the internal hard disk seemed to run through a typical boot sequence. So I stuck in a formatted floppy, which the SE appeared to read properly. Now the test: I hit Command-E on the keyboard and phwang, out pops the floppy. Now that we know the CPU is OK, it's time to open the case and take a look at the analog board. I did this and discovered the connector to the rear of the video tube had popped off. It seems there's this thick grounding cable or some such with very little slack that can yank the connector off the tube when the SE gets jarred. Apple needs to put some slack in that wire: I've heard of this happening to another SE user.

At any rate, fixing that problem was simply a matter of plugging the connector back on. The hard disk seems OK, and I'm using the SE now to file this comment. But be advised: I don't think the SE is nearly as shippable as the classic Macs. Be careful!

macintosh/mac.se #238, from wbeck, Wed Jun 10 01:08:39 1987. A comment to message 235.

How did you ship the SE? Did you use a special shipping container, or just the standard box the SE comes in?

Another question: Have you heard any stories of the hard drive being damaged by carrying the SE from home to work, etc.? I do this two or three times a week with my SE, and I am a little scared that the disk will crash eventually. So far, I haven't had any problems at all in the month that I've had my SE (and I am hoping that my luck will remain on track. . .).

macIntosh/mac.se #239, from tom__thompson, Wed Jun 10 09:28:08 1987. A comment to message 238.

I also had the experience of shipping the SE as regular baggage in its canvas bag. The baggage guys mashed it so bad the main power cords were loosened. The internal hard disk didn't lose a byte. I dunno how without parking. Apple says it's because it's a low-mass head.

macintosh/mac.se #241, from reviews6 (Joel West), Thu Jun 11 21:18:10 1987. A comment to message 239.

A techie at a company that makes internal hard disks showed me the internal 20 and commented on the lack of shock mounting. The Apple is much less than the norm for a transportable (e.g., as on a Compaq), but since he's a software type, he wasn't sure if it really mattered.

HOOKING A MULTISYNC/SCAN TO THE MAC II

macintosh/mac.ii #196, from reviews6, Fri May 15 18:49:15 1987.

A local dealer kindly provided me with the manual for the NEC MultiSync. It provides a detailed pin assignment and advice for use with non-IBM drivers. The information seems pretty clear on hooking one up to a Mac II, although, according to Apple's shipment desk, if a developer hasn't received one yet, the next batch is a month away.

continued

8051
8048

SIMULATORS - CROSS ASSEMBLERS - PROGRAMMERS - SIM51 and SIM48 Software Simulators run on IBM-PC, CP/M-80, MS-DOS. Designed for validation & debugging application software. Simulation includes all on chip functions plus expansion chips. \$250, one year **FREE** updates. Formats: PC-DOS 2.x DSDD, CP/M-80 8" SSSD, many 5 1/4" formats. Cross Assemblers and EPROM pgmrs also available. **Logical Systems Corp.** 6184 Teal Station, Syr., NY 13217. (315) 478-0722.

Logical Systems

Inquiry 157

AC/FORTRAN™ **AMIGA**

Mainframe quality, full feature **ANSI FORTRAN 77** compiler includes **Debugger**, **Linker**, **Library Manager**, **Runtime Library**, **IEEE math**, and **C interface**. Supports **Complex numbers**, **Virtual arrays**, **Overlays** and **Dynamic Linking**. Not copy protected. Available now. \$295. Turbo Amiga version also available.

AC/BASIC™

From the authors of **Microsoft BASIC** compiler for Macintosh, comes **AC/BASIC** for the Amiga. Companion compiler to the **Amiga BASIC** interpreter. Has more features and includes a **Debugger**, includes **BLOCK IF**, **CASE** statement, and **STATIC** keyword extensions and executes up to **50x** faster. **AC/BASIC** is the new BASIC reference for **MEGABYTE** based personal computers. Not copy protected. \$295.

Telephone orders welcome

abs:ft

Scientific Engineering Software
2781 Bond St., Auburn Hills, MI 48057, (313) 853-0050
Amiga trademark of Commodore Amiga
Microsoft trademark of Microsoft Corp.

ATARI

Inquiry 3

TERMINAL EMULATIONS

NEW SOFTERM PC, RELEASE THE LEADER IN EXACT TERMINAL EMULATIONS

- * OVER 30 EMULATIONS
- * KEYBOARD MACROS
- * VIRTUAL DISK CAPABLE
- * KEYBOARD TRANSLATE
- * CAPTURE FILES TO DISK OR PRINT
- * FILE TRANSFERS WITH 7 PROTOCOLS (I.E. KERMIT-SERVER, HAYES, XMODEM, ETC.)
- * CONCURRENT AND BACKGROUND COMMUNICATIONS AND MORE!!!

A COMPLETE EMULATION & COMMUNICATION PACKAGE

SEIFTRONICS
800/225-8590
CALL FOR INFORMATION
(303)593-9540

TELEX 450236

Inquiry 269

SATELLITE ELECTRONICS



**Catch the Excitement!
Today, High-Tech Job
Opportunities are
Everywhere!**

Now you can take control of your future with NRI's newest hands-on training and carve out your own place in today's electronics world. Select a new career field or start a business of your own. Now the choice is yours. And only NRI gets you where you're going with the *latest* professional instruments and test equipment you build and keep as you learn at home.

No other school of its kind has prepared so many people for successful careers in electronics. For over 70 years, NRI technical engineers and educators have demonstrated a unique ability to spot and anticipate the important technological trends, then develop state-of-the-art training that's prepared over 1.3 million ambitious people for successful careers in each new emerging field.

Now NRI presents *three* new state-of-the-art training opportunities in today's fastest growing electronics fields.

Build Your Own IBM-Compatible Computer as You Learn Digital Electronics Servicing.

A brand new course for an exciting new field... servicing computer peripherals (disk drives, printers, display terminals, modems, etc.) and the latest digital equipment found in industry today. Job opportunities for the trained digital technician have never been greater. It takes skilled personnel to keep today's digitally automated production lines and manufacturing equipment rolling. NRI trains you to be a high-demand digital technician or prepares you for your own independent service business.

As you learn, you get practical hands-on experience building your own 256K, IBM-compatible NRI Model XT computer—complete with disk drive and monitor. When you add NRI's exclusive diagnostic software, you transform your computer into a dedicated digital testing device for troubleshooting video displays

ROBOTICS

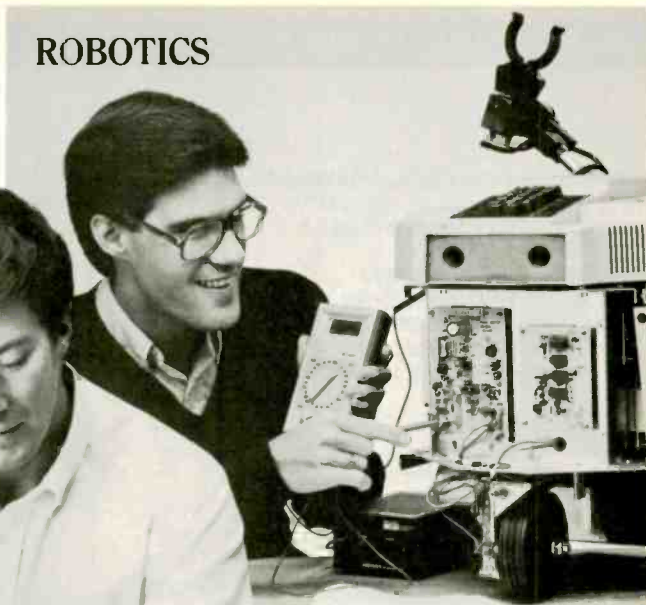

mobile robot. You get professional instruments and up-to-date training to prepare you to handle the technology that's changing the face of industry today.

Install and Troubleshoot Your Own Home Satellite TV Equipment as You Learn Satellite Electronics.

You've seen them in backyards, beside motels, atop office buildings, and in military installations—those sensitive dishes reaching out for TV programs, computer transmissions, data signals, and messages of all kinds from the growing number of satellites stationed 22,300 miles above the earth. Now NRI training can get you in on the ground floor of a new career or even a business of your own in this exciting new growth field.

NRI trains you to service consumer TVRO systems, as well as the larger commercial and military equipment used to transmit and receive worldwide communications: news, weather, national security & defense transmissions and all types of voice, data and video signals.

Learn to install satellite systems... adjust, troubleshoot and repair dishes, amplifiers, converters, antennas and receivers. And get "hands-on"

experience as you install your own satellite TVRO system that will bring TV signals from around the world into your home.

Send for Free Catalog of High-Tech Career Opportunities.

Now you, too, can catch the excitement. Just send for your free copy of the 100-page NRI High-Tech Electronics Careers catalog. See the future open up for you as you explore exciting new opportunities for higher pay, advancement—even your own business. Review the complete descriptions of the training you get, the equipment that makes each opportunity come to life. Send today and get your start on tomorrow. If the card is missing, write to us.

DIGITAL ELECTRONICS SERVICING

Only NRI trains you for so many careers on the leading edge of today's electronics revolution.

and terminals, disk drives, and more!

You also build and learn to use and service your own triggered-sweep oscilloscope, digital logic probe, and digital multimeter... instruments used by today's digital electronics professionals.

When you select NRI training in Digital Electronics Servicing, you'll be preparing yourself to move into one of today's hottest electronics careers!

Build an Operating Robot as You Learn Robotics and Industrial Control.

Already, advanced robotics systems are producing everything from electronic circuits to automobiles. By 1990, over 100,000 "smart" robots will be in use, creating over 30,000 new technical jobs.

NRI trains you to operate, program, service and troubleshoot industrial robots as you build your own remote controlled, programmable

NRI School of Electronics

McGraw-Hill Continuing Education Center
3939 Wisconsin Avenue
Washington, DC 20016

We'll Train You For Tomorrow.



SPECS

NEC MultiSync JC-1401P3A, primarily designed as an EGA-compatible TTL (digital RGB) monitor, includes IBM Professional Graphics Adapter compatibility.

Resolution: 800x560
 Analog 0.6V p-p 75 Ohm
 Video bandwidth: 30MHz
 Synchronization: Horizontal 15.5-35KHz
 Vertical 56-62 KHz, noninterlace

SETTINGS

Analog/TTL: Analog
 Manual: On

CABLE

NEC DE9 Description Apple video card ("DB"-15)

1	Red	2 Red
2	Green	5 Green
3	Blue	9 Blue
4	Composite Sync	3 CSync
5	V. Sync	N/C or 1 Ground
6,7,8,9	Ground	1 Ground

macintosh/mac.ii #212, from reviews6, Thu May 21 22:01:55 1987.

The Sony Multiscan, like the NEC MultiSync, is a monitor designed for compatibility with several IBM standards. It handles PGA and VGA.

It also works very nicely with the Mac II. I'm told that it looks identical to the Apple monitor except for the case. (Apple has acknowledged using a Sony tube; other differences are unclear.)

I also heard that only the late-model NECs can handle the Mac's scan rate.

A LOOK AT NUBUS COMPATIBILITY

macintosh/mac.ii #205, from murdock (Albert Sousa), Mon May 18 22:06:27 1987.

Will TI NuBus cards work on the Mac II? I'm referring to the LISP processor card on the Explorer and the memory, CPU, and peripheral cards from the Business Pro. Also, a magazine made reference to a new Mac in alpha. It said this new Mac was as big a jump over the Mac II as the II was over the Plus. Any comments?

macintosh/mac.ii #210, from nwallach (Naor Wallach), Thu May 21 19:48:48 1987. A comment to message 205.

Looking at the pictures from AST for its 286 card, I believe that Apple has developed its own form factor for its cards. I do not believe that it has followed the NuBus spec in its mechanical design. Therefore, no NuBus card compatibility. Electrically, Apple used NuBus though.

macintosh/mac.ii #216, from tom__thompson, Tue May 26 14:12:26 1987. A comment to message 210.

I think it's the other way around: Apple has followed the form-factor (mechanical) specs from the NuBus doc, but it's only partially compatible electrically. If the card requires the -5.2V that the Apple NuBus doesn't supply. Except for this one change, the Mac II follows the NuBus electrical specs closely and should work.

macintosh/mac.ii #233, from nwallach, Sun May 31 21:03:48 1987. A comment to message 216.

The spec I have mentions a form factor that is identical to VMEbus. I'll check my spec if someone will post the mechanical dimensions for their Apple NuBus cards.

macintosh/mac.ii #240, from tom__thompson, Mon Jun 1 09:06:56 1987. A comment to message 233.

Just a guess, but what version of the NuBus spec do you have? I had spec. 1.6, which only *mentioned* the VME form factor. Things didn't look too pleasant electrically, either. However, when I received my copy of the NuBus spec, I found out it's now in draft version 2.0. Apple is pretty well in order with the electrical definitions (except for the -5.2V), and a "PC" form-factor card was introduced. The dimensions for the PC form factor are:

101.6mm (4.0") in height
 327.03mm (12.875") in length max.

Length shall vary on left side of card; minimum length is 177.8 mm (7.0").

Connector is a Eurocard type C connector; specifically, 603-2-IEC-C096-M.

This is probably the form factor Apple is using for the boards (certainly not the VME form factor!).

macintosh/mac.ii #243, from nz__mhamel, Tue Jun 2 04:17:46 1987. A comment to message 240.

I thought Apple was a bit more deviant than that from the NuBus spec: Hasn't A31, which was a ground, become an interrupt line, IRQ*? And Apple doesn't support block transfers (or is that optional now?)

macintosh/mac.ii #244, from jmonti, Tue Jun 2 04:37:39 1987. A comment to message 243.

Yes, upgrading the video card is just a matter of putting in the chips. I saw it done and it took about 2 minutes, maybe 3. And the chips weren't even from Apple. I believe \$41 is a reasonable price if bought in quantity through a user's group co-op or something.

macintosh/mac.ii #247, from tom__thompson, Tue Jun 2 09:04:53 1987. A comment to message 243.

No, A31 is an address/data line, it can't be a ground. The interrupt request is row RQST*, which can be busd or non-busd (Apple chose the latter route, so that each card could have its own dedicated interrupt). No, the Mac II doesn't support block transfers, and they are optional in version 2.0 of the spec.

macintosh/mac.ii #249, from nwallach, Tue Jun 2 19:29:58 1987. A comment to message 240.

Hmmmmmmmmmm!

My spec. is document #TI-2242825-0001, published by Texas Instruments. You know, the people who developed NuBus.

Of course, there is nothing to say that they are perfect. Thanks anyway.

macintosh/mac.ii #250, from sjones (Scott Jones), Tue Jun 2 19:36:06 1987. A comment to message 249.

You're wrong! TI didn't develop the NuBus. Some of my

continued

Compose Yourself!

Now create superb sounding music on your IBM® PC. Ad Lib™ makes it easy.

Just when you thought you'd heard it all, along comes Ad Lib.

And with it comes rich, room-filling music like you've never heard from a PC before. With rumbling bass, crystal clear highs, up-front mid-range. All of it composed and performed on the first complete PC music system for people like you — long on desire, a little short on experience.

The heart of the system is the Ad Lib Music Synthesizer Card™. An electronic sound synthesizer based on the same digital technology found in professional keyboards and the finest music computers.

Just plug it into your PC and get clean, powerful music through high fidelity headphones, bookshelf speakers, even your home stereo. It'll handle up to eleven different instrument sounds playing at once, so it's perfect for anything from a solo to a symphony.

There's also Ad Lib Visual Composer™, about the most instinctive composition software ever devised. Simply draw lines to indicate notes, using the on-screen piano keyboard as a guide. Change instruments, tempo and volume with a couple of keystrokes. Cut, copy and paste portions of your music in a snap.

Included with the program is Composition Projects™ #1, a step-by-step guide to creating all kinds of music, including classical, jazz, bossa nova, ragtime, and more. Just the thing for an ever-expanding repertoire.

Visual Composer is worth \$89.95 if purchased separately, but it's yours free when you buy the system.

Then play back all of your creations, as well as several pre-programmed selections, on the Juke Box™ playback software, also included with your system.

Look for the Ad Lib Personal Computer Music System™ at selected computer and music stores, or order direct from Ad Lib with your check, Visa or MasterCard.

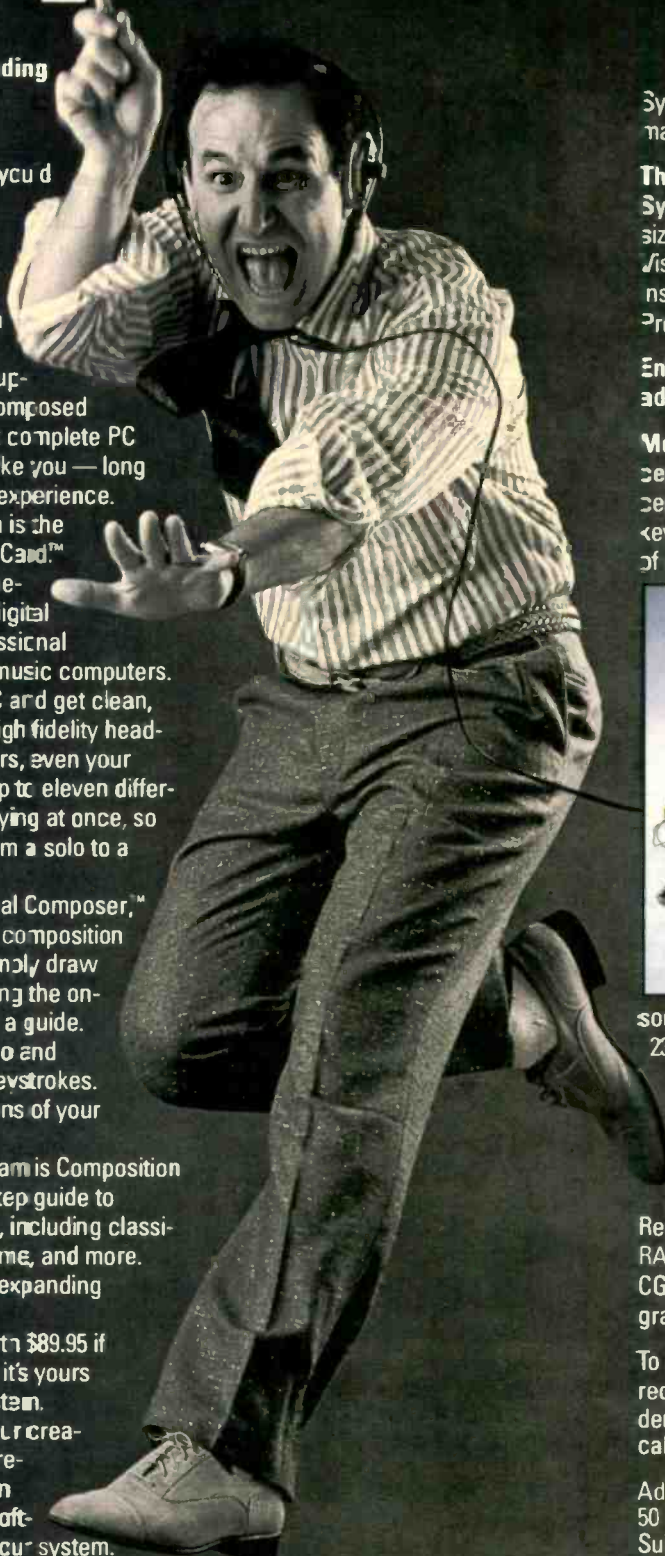

The Ad Lib Personal Computer Music System. At last you have what it takes to make great-sounding music.

The Ad Lib Personal Computer Music System. Includes the Ad Lib Music Synthesizer Card, Juke Box playback software, free Visual Composer software with 50 pre-set instrument sounds and Composition Projects #1 \$245.00

Enhance your system further with this additional Ad Lib software:

Music Championship™ #1 — Basic Concepts. Learn to identify basic musical concepts, including tempo, mode, rhythm and key. Perfect for all ages. The first in a series of music training programs combining syn-



thesized music with exciting computer game competition . . . \$39.95

Instrument Maker™ software. Lets you create and save new instrument

sounds for use with Visual Composer. Alter 23 sound characteristics like attack, sustain and decay. Modeled after professional music synthesizer software . . . \$49.95

Look for more Ad Lib music software titles coming soon.

Requires IBM PC, XT, AT or compatible, 256K RAM, DOS 2.0 or higher, CGA, EGA or monochrome graphics adapter.

To place your order, or to request your free demonstration recording, call us toll-free today.

Ad Lib Inc.
50 Staniford Street
Suite 800
Boston, MA 02114



AdLib
Personal Computer
Music System

1-800-463-2686

Inquiry 334

299

Ad Lib, Ad Lib Personal Computer Music System, Visual Composer, Juke Box, Composition Projects, Instrument Maker and Music Championship are trademarks of Ad Lib Inc. IBM is a registered trademark of International Business Machines Corporation.

professors at MIT developed it a number of years ago. TI just licensed the NuBus from them! I was surprised to hear that Apple had chosen it for the Mac II. I still have some course notes describing the bus-arbitration protocol that the professors had designed [from a class called 6.032].

macintosh/mac.ii #251, from tom__thompson, Tue Jun 2 21:27:15 1987. A comment to message 250.

What's the date on that thing? I've got the IEEE P1196 specification, draft 2.0, dated December 15, 1986. It's also an unapproved draft, but since it's still in the proposal stage (hence the "P" with the spec number), no big deal. No idea when it'll be finalized, but this document's the latest I've seen.

macintosh/mac.ii #252, from paul.hoffman (Paul Hoffman), Wed Jun 3 00:15:09 1987. A comment to message 250.

Ah, 6.032. Course name: Computers for Masochists. Brings back memories.

macintosh/mac.ii #253, from microprose (MicroProse Software), Thu Jun 4 22:36:58 1987. A comment to message 252.

Lord, 6.032! Haven't thought about that in years! Guess I took it before NuBus was created (Fall '80). . .

macintosh/mac.ii #254, from sjones, Thu Jun 4 23:53:31 1987. A comment to message 253.

Hmmm, all these MIT types coming out of the woodwork!

I do wish that Apple had kept in some of the features of the NuBus. Like the fast block transfers.

IBM PC

Can you use a single-sided 3 1/2-inch floppy disk in one of the new 1.4-megabyte PS/2 drives? It seems so at first glance. But wait, there's more. If that isn't enough to pique your interest, you can read all about the stuttering ROM BIOS or the nonfunctioning alternate Alt. In the realm of the more contemporary PS/2 systems, there's a discussion of the pros and cons of the Micro Channel bus and bus ID numbers. This month's IBM PC section finishes up a thread on how EXEC does temporary exits to DOS.

THE DANGERS OF SINGLE-SIDED DISKS

ibm.ps/model.50 #214, from swnev (Scott Neville), Mon Jun 8 23:59:02 1987.

I had an old single-sided 3 1/2-inch disk laying around, and, just for kicks, I decided to see if it would format properly. I used the FORMAT command without any parameters, and lo and behold! It formatted fine and showed a full 1.4 megs of available space!

I confirmed this with CHKDSK. I couldn't believe it, so I copied over a meg of data onto the disk (actually programs and ASCII files). I used the /v (verify) option with the copy and got no errors. Every program I run off the disk works without a hitch. The ASCII files are complete and unadulterated!

Is there a mega\$\$\$ conspiracy afoot? Am I being overcharged for high-density disks, when any old 3 1/2-inch disk will work? Is there a difference in reliability between these disks? Anyone have any suggestions?

ibm.ps/model.50 #215, from barryn (Barry Nance), Tue Jun 9 00:01:04 1987. A comment to message 214.

Good question. Even with a discount, the 3 1/2-inch disks we bought at work cost about \$60 per box. And that's too much.

ibm.ps/model.50 #216, from swnev, Tue Jun 9 00:09:23 1987. A comment to message 215.

I have some Sony single-sided disks. I'll try them next. The store I bought my Model 60 from wanted \$100 for the hard disks! I finally found them for \$65. Seems way overpriced. I chalked it up to new technology, but now I begin to wonder!!

ibm.ps/model.50 #217, from barryn, Tue Jun 9 00:11:48 1987. A comment to message 216.

Well, just watch out for the single-sided disks. . . "single-sided" means that the disks failed the certification tests on one surface but not the other. There could be a very slight flaw on the bad side. . . or there could be a large one.

ibm.ps/model.50 #220, from grr (George Robbins, Commodore Business Machines), Tue Jun 9 04:56:58 1987. A comment to message 217.

This is an open issue that has been explored elsewhere at great length. It boils down to personal preference. Some people are happy to save a buck at some increased risk; others are willing to pay more for some assurance of better data reliability.

The details of certification, finishing, testing, and whatnot vary between manufacturers and over time. There isn't a single answer.

ibm.ps/model.50 #227, from matt.trask (Matt Trask), Tue Jun 9 11:32:59 1987. A comment to message 217.

Single-sided means a statistically meaningful sample from the production run failed on one surface and not the other - not necessarily every disk. DOS should be able to handle any bad sectors that are found during format of a single-sided disk for double-sided use.

STUTTERING ROM BIOS

ibm.ps/model.50 #230, from barryn, Tue Jun 9 21:03:42 1987.

I dumped the ROM BIOS of my Model 60 out to disk earlier today, just so I could do some spelunking. Here's a picture of the front end of the file:

```
-d 100
9900XX66881158
((CC))CCOOPPYRRIIGGHHTT
IIBBMM CCOORRPPPOORPAATTIIOONN
11998811,, 11998877
AALLLL RRIIGGHHTTSS
RREESSEERRVVEEDD
```

ibm.ps/model.50 #231, from greenber (Ross Greenberg), Tue Jun 9 21:33:57 1987. A comment to message 230.

WWhhaatt' 's wwrroonngg wwiithh tthhaatt??

Barry, what do you get if you output that as a direct image to the screen, using the alternate bytes as attribute bytes? Must look pretty funny.

continued

DANCE IN THE AISLES

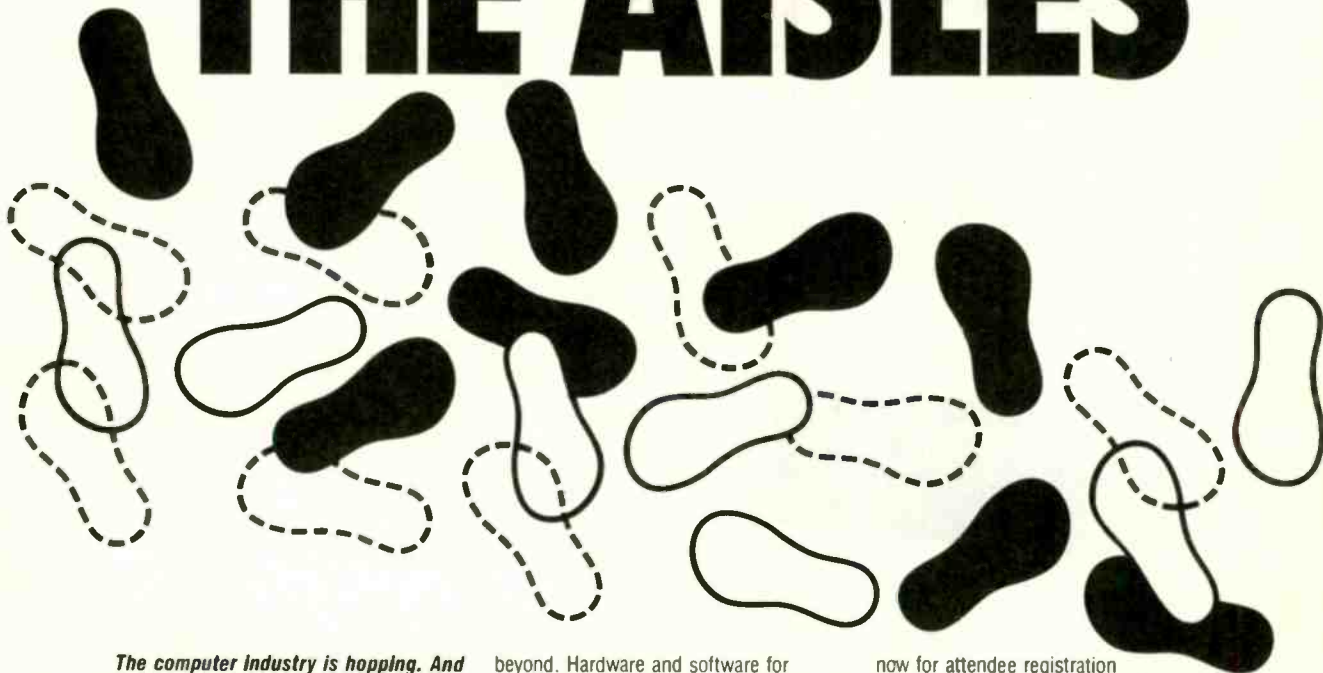

The computer industry is hopping. And COMDEX/Fall '87 is the place to roll back the rug, kick up your heels, and get down to business with more than 1300 exhibitors in a "sold out" show.

COMDEX/Fall '86 and COMDEX/Spring '87 proved that the industry had regained its form. The former signaled the resurgence, and the latter became the most successful Spring show ever, with over 52,000 attendees.

The perfect partner for VARs, VADs, distributors, OEMs, and other resellers, COMDEX/Fall '87 pairs you with suppliers of the newest products and services that will vitalize your sales for 1988 and

beyond. Hardware and software for communications, CAD/CAM and desktop publishing, multi-user systems, micro-mainframe integration, workstations, local area networks—you can take a turn with all the liveliest opportunities of the season.

And you'll step up your sales momentum through such Conference exclusives as field reports from users and resellers on IBM's new generation of desktop machines, Apple's Macintosh series, and through seminars on desktop publishing, CAD/CAM and corporate connectivity.

COMDEX/Fall '87 is where the industry is hopping. Fill out and send in the coupon

now for attendee registration information. Or write to COMDEX/Fall '87 Attendee Registration, 300 First Avenue, Needham, MA 02194.

COMDEX/Fall has me dancing in the aisles!

- Send me complete attendee information, including registration form, hotel and travel discounts.
- Send me exhibitor wait list information.
- Have a Sales Representative call me.

Name _____

Title _____

Company _____

Address _____

City _____ State _____ Zip _____

Return to: COMDEX/Fall '87 Attendee Registration
300 First Avenue, Needham, MA 02194

BY987

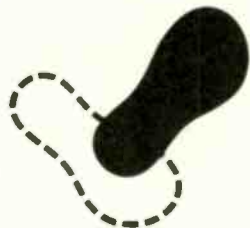

COMDEX®/Fall '87

November 2-6, 1987 • Las Vegas • Nevada

Produced by THE INTERFACE GROUP, Inc.

©1987 The Interface Group, Inc. C0206

Rack & Desk PC/AT Chassis

A Fresh Approach

Integrand's new Chassis/System is not another IBM mechanical and electrical clone. Appearance, power, thermal, reliability and EMI problems that plague other designs have been solved. An entirely fresh packaging design approach has been taken using modular construction. At present, over 40 optional stock modules allow you to customize our standard chassis to nearly any requirement. Integrand offers high quality, advanced design hardware along with applications and technical support *all at prices competitive with imports.* Why settle for less?



Rack & Desk Models

Accepts PC, XT, AT Motherboards
and Passive Backplanes

Doesn't Look Like IBM

Rugged, Modular Construction

Customize with over 40 Stock Panels

Excellent Air Flow & Cooling

Optional Card Cage Fan

Designed to meet FCC

204 Watt Supply, UL Recognized

145W & 85W also available

Reasonably Priced

Made in USA

INTEGRAND
RESEARCH CORP.

Call or write for descriptive brochure and prices:
8620 Roosevelt Ave. • Visalia, CA 93291
209/651-1203

TELEX 5106012830 (INTEGRAND UD)

EZLINK 62926572

We accept BankAmericard/VISA and MasterCard

IBM, PC, XT, AT trademarks of International Business Machines.
Drives and computer boards not included.

• BEST OF BIX • **BIX** • BEST OF BIX • BEST

ibm.ps/model.50 #232, from barryn, Tue Jun 9 21:37:27 1987. A comment to message 231.

I can try it when I get to work tomorrow. I wonder if it'll blow up the machine (hope, hope).

ibm.ps/model.50 #233, from mced (Edward McNierney, Number Nine Computer Corp.), Tue Jun 9 22:52:42 1987. A comment to message 232.

Ge, these software guys don't know much about hardware, do they?

Actually, I've wondered about that BIOS stuttering for years (you can find it in every PC from the very first one) until I started working for a hardware company. You see, ROMs are usually organized as "by 8," meaning that they can be accessed 8 bits at a time. Since 16-bit accesses are much faster if you don't have to read the same ROM twice, IBM (and most everyone else) arranges ROMs as two 8-bit ROMs with their addresses interleaved. In other words, all the even-numbered bytes are in one ROM and all the odd-numbered bytes are in the other. Most software for burning ROMs comes with a "byte-split" utility, which takes your object code and splits it into two files, one for each ROM.

So, all IBM is doing is making sure that the complete text of the copyright message is stored in each ROM!

ibm.ps/model.50 #234, from barryn, Tue Jun 9 22:59:42 1987. A comment to message 233.

Well, that *does* make sense. Thanks, Ed.

ibm.ps/model.50 #237, from barryn, Wed Jun 10 02:56:19 1987. A comment to message 232.

Does anyone have a clone that has a "stuttering" BIOS footprint like that? Mine doesn't; its front end is a perfectly readable copyright message (maybe this means that the low-byte ROM chip is not copyrighted unless it's treated as a set along with the high-byte chip, and vice versa?).

ibm.ps/model.50 #239, from matt.trask, Wed Jun 10 11:44:14 1987. A comment to message 237.

I suppose they could protect their rights by only copyrighting every other byte. Any 16-bit machine (8086, 80286, . . .) should exhibit this same stutter.

THE NONFUNCTIONING ALTERNATE ALT

ibm.ps/model.50 #259, from swnev, Sun Jun 14 12:30:36 1987.

The second Alt key (to the right of the space bar) isn't recognized by any of my programs. The second Control key (also to the right of the space bar) functions normally. Do I need to trade in my keyboard? Or did IBM just do something different with the second Alt key? Also, does anyone know how to make use of the F11 and F12 function keys? I don't have the Tech Ref yet; do they use special return codes?

ibm.ps/model.50 #265, from kkonnerth (Karl Konnerth), Mon Jun 15 01:40:15 1987. A comment to message 259.

We haven't had many problems with the Alt keys on our 50s and 60s. Occasionally, a program will reject one of the Alt keys, but it happens so infrequently that I can't remember which program was affected! Have you run the diagnostics yet? Note bene: You can access the advanced diagnostics by pressing Control-A at the main menu for the Reference Disk.

continued

THIS IS BB^x.™

THE MOST WELL KNOWN PROGRAMMING LANGUAGE YOU'VE NEVER HEARD OF.

If you're in the business of programming business solutions, you need to know about BB^x.

Throughout the world, the industry's best and brightest programmers are discovering the power that BB^x brings to Business BASIC.

And the numbers are growing. This year, over 30,000 copies of BB^x are performing across the United States, Canada, Europe, Asia and South America.

BB^x IS GOOD COMPANY WITH SOME GOOD COMPANIES.

The BB^x name is well known to some of the most well respected names in the computer industry.

Open Systems, Altos and State of the Art have adopted the BB^x language for their accounting packages. NCR selected BB^x as their standard Business BASIC offering.

These diverse companies, with very different needs, depend on the wide-ranging capabilities of BB^x and the availability of over 1,000 BB^x vertical application packages ranging from hospitality to waste management.

IT MATTERS THAT YOU'RE RUNNING BB^x. IT SELDOM MATTERS WHAT COMPUTER.

The power of BB^x is unique in its enhancement of the Business BASIC language. You'll discover, though, that there need not be anything special about the computer you're programming.

BB^x will make you a believer on most every major computer brand available today. And BB^x is portable. With BB^x, you have guaranteed portability of your application across all supported operating environments. This means a program written on a single-user PC can run with NO modification on over 35 different UNIX computers!

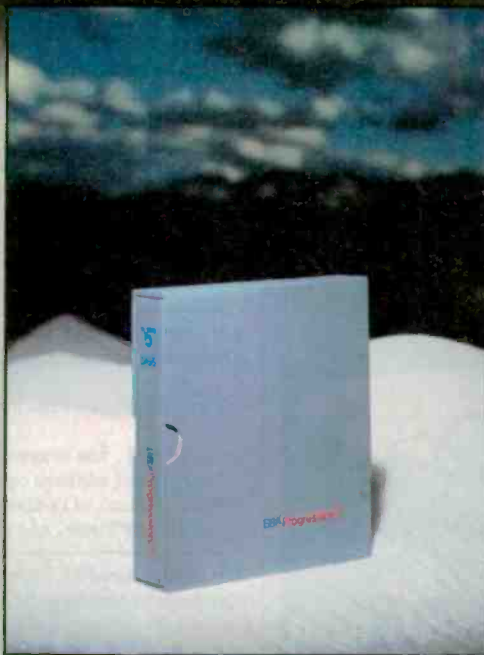

BB^x IS THE SINGLE BIGGEST STEP YOU CAN MAKE TO OPTIMIZE YOUR BUSINESS BASIC LANGUAGE.

And it begins with this step. Call us at BASIS Incorporated. Find out how you can stay in step with the thousands of BB^x programmers and bring an entire new dimension to your business applications.

We'll send you information on our just released BB^x Progression/2, the newest, most advanced programming language from BASIS.

BB^x Progression/2 will do much more than add personality to your language. That's not the half of it.

BB^x Progression/2 will give your Business BASIC a whole new character.

To order BB^x Progression/2
in the United States please
call TOLL FREE directly,
1-800-423-1394

In Canada, 1-416-494-0472

For technical support or more information,
1-505-821-4407

To order BB^x Progression/2 in
Europe please contact one of our
European distributors,

EDIAS, Hans Kirchhoff, Pfingstbornstrasse 25
6200 Wiesbaden, West Germany
Phone: (0 61 22) 2016 Telex: 418 25 63 edia d

PI Informatique, 8 rue Benjamin Constant
75019 Paris, France

Phone (1) 40.05 10.65 Telex: 214.582
MULTISYS A S, Torgeir Vraas Plass 5A
3044 Drammen, Norway
Phone: (03) 83 86 05 FAX: (03) 89 02 59

BASIS Incorporated
P.O. Box 20400
Albuquerque, New Mexico USA 87154
Electronic Bulletin Board 1-505-821-2933
MCI Mail, Basis (255-8242)
Telex 6502558242 mci

BB^x is available on most popular UNIX, DOS and Network environments. Please call for assistance with your particular requirements.

UNIX is a trademark of Bell Laboratories
NCR is a trademark of NCR Corporation.
Altos is a trademark of Altos Computer Systems
Xenix is a trademark of Microsoft Corporation.

BB^x IS SETTING NEW STANDARDS WITHIN A 15-YEAR STANDARD.

BB^x is simply the most contemporary implementation of one of the most traditional products in computer programming.

Features like pop-up windowing on dumb terminals, device independent graphics, multi-keyed files, string arrays, long variable and function names, trigonometric functions, matrix arithmetic, and others are simpler and swifter than you ever thought possible.

There are many other examples of BB^x excellence like its callable business graphics utility set that makes graphics presentation of your data easy.

BB^xProgression/2™

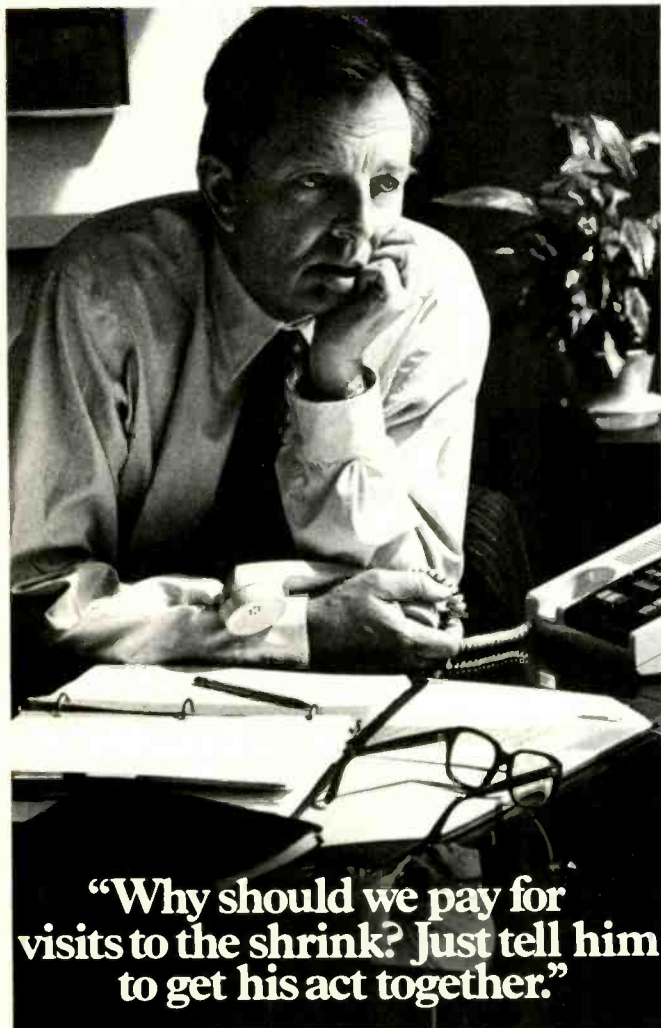

“Why should we pay for visits to the shrink? Just tell him to get his act together.”

In companies where professional treatment for mental illness is still viewed negatively, everybody suffers.

The employee, fearing how it will look on his record, suffers by not seeking treatment.

And the company suffers. From increased absenteeism and loss of productivity.

But you can help change all that. By recognizing that mental illness is a medical illness that requires medical treatment. And by looking into medical insurance coverage that encourages employees to seek professional treatment without fear or hesitation.

Today, many companies have successfully improved employee performance by structuring their health plans to include long and short term treatment.

Learn more. For an informative booklet, write: The American Mental Health Fund, P.O. Box 17700, Washington, D.C. 20041. Or call toll free: 1-800-433-5959. In Illinois, call: 1-800-826-2336.

Learn to see the sickness. Learning is the key to healing.
THE AMERICAN MENTAL HEALTH FUND



BTW, not many programs used F11 and F12 when that keyboard was offered with the XT and AT, and not many use it now. I seem to recall that they require a separate BIOS call to read.

A LOOK AT THE MICRO CHANNEL BUS

ibm.ps/the.bus #50, from greenber, Tue Jun 9 09:03:50 1987.

Well, now that the smoke has cleared a bit (and now that I finally have my Tech Ref so I understand the answers!):

Q: What makes the Micro Channel superior to the old XT bus? To the old AT bus? To other buses put out by other companies?

Q: These IDs that IBM promises to give to everybody: Is that the only way to get them, or can manufacturers make a deal and split a given number in some way between themselves?

Q: What peripherals might be uniquely suited to the PS/2 and why? In fact, why isn't the motherboard, and the CPU on it, considered a peripheral?

Q: When the Model 80 comes out, will the real power of the 386 shine through on the Micro Channel? Or will the Micro Channel start to shine when powered by the 386?

Well, now that I can follow what the heck people are gonna say, I'll try to translate a bit as required.

ibm.ps/the.bus #51, from matt.trask, Tue Jun 9 11:38:28 1987. A comment to message 50.

yes yes yes no yes size 9 yes maybe yes

Well, anyway, the reason the CPU is not a peripheral is because guest masters on the bus cannot control the watchdog timer - control will always return to it. Of course, if the CPU disables the timer, all bets are off.

ibm.ps/the.bus #52, from greenber, Tue Jun 9 11:46:42 1987. A comment to message 51.

Now, since I'm just starting to wade through the tech spec, perhaps you can help me out:

What the heck *is* the watchdog timer, and should I care that it exists?

ibm.ps/the.bus #53, from matt.trask, Tue Jun 9 12:02:31 1987. A comment to message 52.

It is a programmable timer that normally would be reset by the BIOS on each timer tick. It can be set for 0 to 255 ticks. If the preset number of ticks occurs without a reset to this timer, it yanks down on the NMI line. This NMI is *_not_* maskable by the normal NMI mask register, and because the timer's ports are below 100h, they are not visible over the bus to other bus masters. This allows the planar CPU to always regain control of the bus from rude bus riders.

ibm.ps/the.bus #54, from greenber, Tue Jun 9 15:42:32 1987. A comment to message 53.

Sounds like there are a lot of nifty things you could do with a decent NMI interrupt-service routine, eh?

What kind of stuff is loaded in there now??

ibm.ps/the.bus #56, from matt.trask, Tue Jun 9 17:27:12 1987. A comment to message 54.

The normal NMI services, such as parity check (yechh!) and NDP error, are implemented through the NMI vector in the normal

continued

MICROMINT'S Gold Standard in Single Board Computers & Controllers

Announcing DT01/DR01 Serial Digital Imaging System

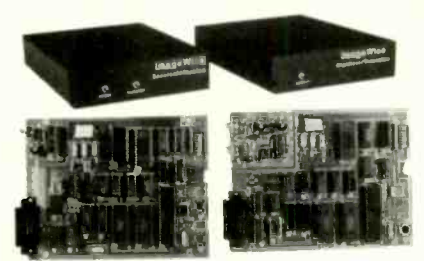

MICROMINT INTRODUCES A STAND-ALONE SERIAL DIGITAL IMAGING SYSTEM. The MICROMINT ImageWise™ Serial Digital Imaging System is the most cost effective and versatile high performance graphics video digitizing system on the market today. The ImageWise system has been designed to function as a standalone digitizer or as an integral component of a complete tele-imaging system. ImageWise™ is serially bit mapped digitized pictures give it almost universal compatibility with any computer capable of attaching to a modem or terminal. It is ideally suited for CAD/CAM, Desktop Publishing, automatic inspection, and security applications. Critical System functions such as image resolution and picture update can be controlled and commanded remotely. Images are transmitted and received serially either compressed or uncompressed, and can be displayed, transmitted, stored, edited, or processed for use in a variety of industry standard application software.

- ### IMAGEWISE SYSTEM SPECIFICATIONS
- NOT bus dependent — can function standalone
 - True frame grabber — uses a high speed Flash A/D converter and 64K bytes of static RAM to capture an image in 1/60th second
 - Accepts any 5V or color NTSC video signal
 - Stores pictures as 644 lines of 640 pixels — 64 levels grayscale
 - Resolution of transmitted image software selectable; all images are represented in 64 levels of gray scale
 - Selectable Resolutions:
 - High 320x484x2
 - Med 192x160x2
 - Low 64x160x2
 - Video Input: 1 wire peak-to-peak B/W or color 75 ohm termination
 - Video Output: 75 Ohm 1.5V peak-to-peak NTSC composite
 - Serial Input/Output: RS-232 — 8 bit, one stop bit, no parity 300 bps — 31.6Kbps select cable data rate — Xon/Xoff Handshaking Switch selectable data compression (optional)
 - Modem compatible: Easy functions as a video telephone to send video images anywhere
 - Video processing, disk upload/download, and display utilities provided for PC-DOS and MS-DOS machines

Optional PC Utilities Disk converts ImageWise™ files for use with popular Desktop and Paint Programs.

DT01 ImageWise Digitizer / Transmitter \$349.00
 DR01 ImageWise Receiver / Display \$349.00



Announcing OEM-286 — \$775.00 complete PC/AT-CPU



Low Power! Expansion Card Form Factor! 100% AT Compatible!

MICROMINT'S OEM-286 is a complete PC/AT-CPU and more. The OEM-286 is the first low power, 100% AT compatible which has been specifically designed for OEM use within the industrial and business sectors. The OEM-286 features the Zymos CMOS PENTIUM set and 100% compatible Award BIOS. The development of the PENTIUM chip set has allowed the 100 IC's on a standard AT to be reduced to 30 IC's and 100 SMMAs. What this means for you is:

- 1) The overall size of a standard AT/PCU has been condensed into the expansion card form factor, (3 1/2" x 3 1/2")
- 2) Power requirements are less than 1 A @ 5 volts
- 3) OEM-286 plugs into a passive backplane for easy connection to other expansion peripherals

The OEM-286 is available in both 8 and 10 MHz versions and comes with the Award BIOS

- ### OEM-286 FEATURES
- 100% AT compatible
 - 80286 Microprocessor @ 8 or 10 MHz
 - 80287 Co-Processor optional
 - 64 Kbytes of ROM, can accommodate 128 Kbytes
 - 512 Kbytes of RAM
 - Keyboard Controller
 - Expansion card size factor
 - Standard interface to the System Expansion Bus
 - Battery backed real time clock
 - Award BIOS included

OEM-286/8	8 MHz AT/PCU	\$775.00
OEM-286/10	10 MHz AT/PCU	\$825.00
OEM-286/10	8 SLOT PASSIVE BACKPLANE	\$118.00

SB180FX — \$409.00 Single Board Computer

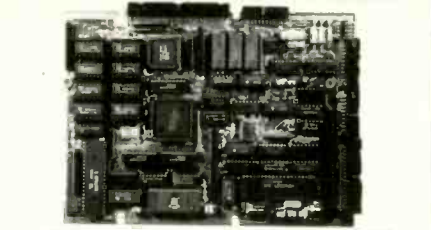

- ### SB180FX TECHNICAL SPECIFICATIONS
- PROCESSOR**
- Intel 80286 10 or 8 MHz CPU in a 40 pin BCC package
 - Support of 2MB instruction set including hardware multiply
 - Integrated Memory Management Unit with 512K bytes address space
 - Dynamic RAM refresh
 - Bus state generator
 - Clocked serial I/O port
 - 8 channel Direct Memory Access Controller
 - 8 channel Asynchronous Serial Communication Interface
 - 8 channel in-line Programmable Keyboard Timer
 - 12 interrupts
 - Dual bus interface to 4MB and 800K support chips
 - 4 16MB, 8 8MB, and 16 800KHz memory operation
- MEMORY**
- 3.1K bytes dynamic RAM on board
 - Memory externally expandable to 4 Mbytes RAM
 - Refreshes at 60, 120, 180, 240, or 300 nsecs EPROM usable
 - Full function 8K ROM resident monitor
- INPUT/OUTPUT**
- Console RS-232 serial port with auto hand raise select to 300 baud
 - Peripheral RS-232 serial port, full hand shaking, 300-3000 baud
 - Line printer parallel I/O port
 - 64 bit bi-directional parallel I/O
 - 16-bit address decoding I/O port decod ring and dual bus interface brought out to expansion bus connector
 - Can be directly attached to DT180 640 x 480 color graphics adapter
 - Fully implemented SCSI hard disk and communications bus interface
- FLOPPY/HARD DISK INTERFACE**
- Uses Standard microprocessors, serial disk controller
 - Compatible with NEC 785A controller
 - On-chip digital data separator
 - Can control 5 1/4", 5 1/4", and 8" floppy disk drives — up to 4 on any combination
 - Handles both FAT encoded single density and MFAT encoded double density data
 - NEC 5320 SCSI bus controller for hard disk or network communication
- SOFTWARE COMPATIBILITY**
- IBM, ZDROS, ZCPDS Compatible

SB180FX-1	SB180FX — 6.144 MHz computer board populated w/ 256K bytes RAM, 8K byte ROM monitor, without SCSI chip. Add \$30.00 for 9 MHz.	\$409.00
SB180FX-1-50	SB180FX-1 computer board as described above with 2 System software including ZDROS, ZCPDS, editors, utilities, ZAS assembler, and ZIM debugger; BIOS and ROM monitor sources, and BIOS for SCSI hard disk. Supplied on five 5 1/4" SB-180 format 5.25DD disks.	\$499.00

SB180 — \$299.00 Single Board Computer

- SB180-1 SB180 — 6.144 MHz single board computer w/ 256K bytes RAM and ROM monitor. Add \$30.00 for 9 MHz. \$299.00
- SB180-1-20 Same as above w/ ZCPDS, ZDROS, BIOS and ROM sources \$389.00
- COMM180-S SCSI Hard Disk Interface \$150.00
- SB180-1 OEM 100 QUANTITY PRICE \$195.00

GT180 — \$395.00 Graphics Display System

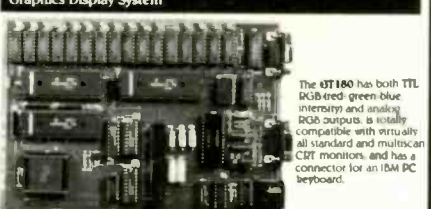

The GT180 offers these features:

- Advanced graphics controller provides intelligent link between computer and display
- Only 3 1/2" x 8" — plugs back on either an SB180 or SB180FX computer
- High resolution at 1 line resolution at 400 x 480 with 4000 dots per inch
- Hardware drawing commands: LINE, RECTANGLE, POLYLINE, POLYGON, CIRCLE, ELLIPSE, ARC, FILLED RECTANGLE, POINT, PATTERN, WINDOW, and COPY to name just a few
- Automatic translation of logical X-Y coordinates to physical frame buffer addresses
- Fast drawing speed of 8 million pixels per second
- Provides fully programmable horizontal split screens and window screen
- Fully supported by GT180 Graphics Toolbox written in Modula 2

GT180-1	Graphic Display Expansion Board (TTL RGB only)	\$395.00
GT180-2	Graphic Display Expansion Board (TTL RGB and Analog RGB)	\$449.00

SB180 Software and Accessories

SB180-U	Uniform Disk Format Conversion Software	\$ 69.95
SB180-ZMSOFTBBS	Z-MSG Bulletin Board Software	\$100.00
SB180-MOD2	Turbo Modula 2	\$ 99.00
SB180-MOD2G	Turbo Modula 2 w/ Graphics Toolbox	\$ 99.00
SB180-CAUSE	Four half height 5 1/4" drive enclosures w/ power supply, mounting brackets and hardware for the SB180 or SB180FX	\$197.00
SB180-CABLE	Set of 4 cables including power, term, disk and print	\$ 79.00

BCC22 — \$249.00 Term-Mite Smart Terminal

Why pay \$500 or more for a smart terminal? The TERM-MITE ST offers you all of the following on a single board for less than 1/4 the price:

- Dimensions 4" x 6 1/2"
- 128 displayable characters
- 64 lines x 80 characters
- 81 escape functions
- Separate transmit & receiver baud rates (110-19200bps)
- CRT refresh at 30-60 Hz
- Supports scanned and encoded keyboards
- 11 Graphic characters
- 25th line reverse video status display
- 14 control functions
- Directly drives composite video or separated sync monitor
- All functions are firmware controlled. Source code available

EDITING FEATURES: typeover, clear to screen to space or null, erase to end of page, erase to end of line, absolute cursor addressing

VIDEO ATTRIBUTES: reverse video, half intensity, double height, double width, underlined, blinking and blink

BUS CONFIGURATION: MICROMINT BCC compatible or no bus connection necessary for stand-alone operation with parallel keyboard

BCC22	TERM-MITE Smart Terminal Board	\$249.00
BCC22K	PARALLEL Encoded ASCII KEYBOARD	\$ 79.00

BCC52 — \$199.00 BASIC 52 Computer/Controller

The MICROMINT BCC52 Computer/Controller is a stand-alone single board microcomputer which needs only a power supply and terminal to become a complete system programmable in BASIC or machine language. The BCC52 uses the Intel 8059AH BASIC microprocessor which contains a ROM resident 8K byte floating point BASIC interpreter. It contains sockets for up to 48K bytes of RAM/EPROM an "Intelligent" 2764/128 EPROM programmer, 3 parallel ports, a serial terminal port with auto baud rate selection, a serial printer port.

BCC52* Basic 52 Computer/Controller \$199.00
 OEM 100 QUANTITY PRICE \$149.00

BCC53 Multi Function Expansion Board w/ 6K add 6 ports and 69K bytes \$160.00

*NOW AVAILABLE IN INDUSTRIAL TEMPERATURE RANGE — CALL FOR INFORMATION

BCC11 — \$139.00 Basic Controller

Features:

- Uses 28 single chip microcomputer
- On board 1MB basic interpreter
- On board parallel ports & serial port
- 4 interrupts (4 external)
- Just connect a CRT and write control programs in basic
- 6K Bytes of RAM or EPROM memory on board
- Data and address bus available for 50K memory and I/O expansion
- Consumers only 1.5 watts at +5, +12 & -12V

BCC11* BASIC System Controller \$139.00

*NOW AVAILABLE IN INDUSTRIAL TEMPERATURE RANGE — CALL FOR INFORMATION

BCC40 — \$159.00 Power I/O Expansion Board

The MICROMINT BCC40 POWER I/O Expansion Board provides on/off control and monitoring of eight 115 VAC or 3-48VDC devices. Up to 16 POWER I/O boards may be used in a system for a total of 64 inputs and 64 outputs.

BCC40 POWER I/O Expansion Board (with no power modules) \$159.00

with 8 Output Modules \$249.99

with 8 Input Modules \$229.99

BCC52 & BCC11 Software and Accessories

BCC52-ROM A	ROM A Utilities-BASIC extensions	\$ 49.95
BCC52-ROM A/B	ROM A and B Utilities	\$100.00
BCC52/41	BASIC extensions and Assembler ROM C Utilities-Real Time Clock and Power I/O firmware	\$ 34.00
BCC52-0K-CLK	SMARTIME BCC52 Clock and ROM C	\$ 69.00
BCC52-8K-CLK	SMARTIME BCC52 Clock w/8K RAM and ROM C	\$ 79.00
BCC53	Multi Function Exp. Board w/8K — adds 6 ports and 69K Byte	\$160.00
BCC00	Serial I/O Expansion Board	\$149.00
BCC09	RS-232 to 20ma Converter	\$ 35.00
BCC13	8 Bit, 8 channel A/D Board	\$129.00
BCC30	18 Bit, 16 channel A/D Board	\$197.00
BCC25-4	4x80 LCD Display	\$199.00
BCC25-8	8x40 LCD Display	\$299.00
BCC22K	Parallel Encoded ASCII keyboard	\$ 79.00

OTHER BOARDS — CARD CAGES — POWER SUPPLIES

MB02	5 Slot mini-mother board (not compatible with CC01, CC09)	\$ 69.00
MB08	8 Slot full mother board (compatible with CC01/CC09)	\$ 85.00
MB44	44 pin gold card edge connector	\$ 6.00
CC01	10 inch Card Cage for one MB08	\$ 99.00
CC02	19 inch Card Cage for two MB08s	\$ 179.00
UPS11	Universal Power Supply — used for single board applications	\$ 79.00
UPS05	9A @ 5V, 3A @ +12V and 1A @ -5V Card Cage Power Supply — designed for 8 or 3 board system	\$ 79.00
UPS10	1A @ 5V, 3A @ +12V, 1A @ -12V Heavy Duty Switching Power Supply — used for an entire BCC system	\$ 69.00
UPS21	5.5A @ 5V, 17A @ +12V, 3A @ -12V 91 Watt Programming Power Supply — used for EPROM programming on the BCC52	\$ 49.00

To order call **1-800-635-3355** for technical information 1-(203)-871-6170 TELEX: 643331



fashion - they are still maskable via the NMI mask register. The new bus time-out mechanism and watchdog timers also cause NMI but can't be masked by this method. (Pause while I shuffle through a TRM - oh well, I saw it somewhere.) There is some method other than the PC NMI mask to shut off the watchdog timer. I thought it was via the BIOS, but now I can't find it. AHA! There it is: For PS systems (except the 30, of course), Int 15h with AH=C3h AL=00h disables the watchdog, and AL=01h enables it with BX=count. This would be subject to protection with a real OS so temporary masters would not be able to seize the bus forever.

ibm.ps/the.bus #55, from grr, Tue Jun 9 16:48:33 1987. A comment to message 52.

When your machine craps out, this gives it a more effective kick in the butt than the keyboard reset. Of course, if the software is the problem as opposed to a hardware glitch, you might get to reboot anyway, but at least you don't have to toggle the red switch. I don't know how well this works; the guy at the seminar said the machines were shipped with this feature disabled.

ibm.ps/the.bus #57, from matt.trask, Tue Jun 9 17:30:09 1987. A comment to message 55.

> When your machine craps out . . .

The bus time-out feature is supposed to save you in this situation. Presuming a real OS that knows about it, this is used to regain control from failed adapter cards that can then be shut off via the POS mechanism. This is also useful with intelligent devices that become bus masters and then crash while running on-board firmware/software.

ibm.ps/the.bus #58, from greenber, Tue Jun 9 19:23:42 1987. A comment to message 57.

Hmmm. So I could set up an NMI intercept, which polls each card to see which one caused a crap-out, and disable it as required. . . .very interesting. . . .

ibm.ps/the.bus #59, from matt.trask, Wed Jun 10 11:49:07 1987. A comment to message 58.

> I could set up an NMI intercept . . .

That is probably the domain of an OS, not some TSR. It is also possible in software to "probe" a board via its slot address and get back a response (assuming the board is working, of course).

ibm.ps/the.bus #60, from greenber, Wed Jun 10 12:22:12 1987. A comment to message 59.

Well, that aspect (probing a board by its slot address) sounds like the real reason for all that board-numbering stuff.

ibm.ps/the.bus #61, from tmarshall (Trevor Marshall, Definicon Systems), Wed Jun 10 23:08:03 1987. A comment to message 60.

I got a call from the IBM address-allocation department today. They wanted ME to suggest a number, which, if it were free, they would allocate it. The catch was that unless I had a manual (which I don't think has been released yet) I couldn't look up the numbers. I told the guy to go recruit some other add-on developers.

ibm.ps/the.bus #62, from dmick (Dan Mick), Thu Jun 11 10:46:29 1987. A comment to message 61.

I guess I would, too. Geez, he wouldn't even give you any suggestions?

ibm.ps/the.bus #65, from tmarshall, Thu Jun 11 23:58:03 1987. A comment to message 62.

Nope. I asked him and he got very upset. You know, the usual "I only work here answering the phone" bit.

ibm.ps/the.bus #63, from matt.trask, Thu Jun 11 11:45:22 1987. A comment to message 61.

IBM reserves 0-32767 for internal use; you can choose from 32768-65535.

ibm.ps/the.bus #64, from jfleming (Jon Fleming), Thu Jun 11 20:57:21 1987. A comment to message 63.

But what about collisions?

ibm.ps/the.bus #70, from matt.trask, Sat Jun 13 08:55:28 1987. A comment to message 64.

In theory, if two boards have the same ID, they'd better be functionally identical. Matter of fact, the IBM guy said that we were welcome to use IDs from their boards if we develop clones. The gotcha is that software is allowed to make assumptions about boards based on the ID number.

ibm.ps/the.bus #78, from jfleming, Sun Jun 14 16:41:15 1987. A comment to message 70.

But let's say that three years from now I design a superfast MITS Altair emulation board or something that *nobody else in the world* is going to be functionally identical to; how do I pick a number that *nobody* else has ever grabbed? Is IBM going to maintain a register?

ibm.ps/the.bus #80, from grr, Sun Jun 14 19:23:10 1987. A comment to message 78.

At the tech seminar at COMDEX, the IBM guys sounded like they *would* register numbers and warn of any collisions. I'm not sure why they don't want to assign numbers; perhaps some political stance.

ibm.ps/the.bus #81, from matt.trask, Mon Jun 15 10:26:11 1987. A comment to message 78.

That's the theory. Actually, at the seminar, the guy said that they would maintain the number list "for awhile," the implication being that they would like someone else to volunteer their services. Sounds like a great opportunity for one of those companies that publishes lists of products - it'd give them a monopoly on knowing everything out there.

If there is a collision between two boards on IDs, the system can't recover; it uses the ID to "sleep" boards with conflicting port and memory needs. I guess they'd both just go to sleep.

ibm.ps/the.bus #66, from tmarshall, Thu Jun 11 23:58:43 1987. A comment to message 63.

Thanks, Matt. I wonder if he will still call me back?

ibm.ps/the.bus #82, from villi (Vilhjalmur Thorsteinnsson), Tue Jun 16 00:12:39 1987. A comment to message 66.

It seems to me you're in a prime position to pick a good ID. . . say 40,000. And IBM has indeed officially said that it will keep the ID number register.

continued

Announcing BYTE's New Subscriber Benefits Program

Your BYTE subscription brings you a complete menu of the latest in microcomputer technology every 30 days. The kind of broad-based objective coverage you read in every issue. *In addition*, your subscription carries a wealth of other benefits. Check the check list:

BONUSES

- ✓ **Annual Separate Issues:** In addition to BYTE's 12 monthly issues, subscribers also receive our annual IBM PC issue free of charge, as well as any other annual issues BYTE may produce.
- ✓ **BYTE Deck:** Subscribers receive five BYTE postcard deck mailings each year—a direct response system for you to obtain information on advertised products through return mail.
- ✓ **Reader Service:** For information on products advertised in BYTE, circle the numbers on the Reader Service card enclosed in each issue that correspond to the numbers for the advertisers you select. Drop it in the mail and we'll get your inquiries to the advertisers.
- ✓ **TIPS:** BYTE's Telephone Inquiry System is available to subscribers who need *fast response*. After obtaining your Subscriber I.D. Card, dial TIPS and enter your inquiries. You'll save as much as ten days over the response to Reader Service cards.
- ✓ **BYTE's BOMB:** BYTE's Ongoing Monitor Box is your



direct line to the editor's desk. Each month, you can rate the articles via the Reader Service card. Your feedback helps us keep up to date on your information needs.

- ✓ **Subscription Service:** If you have a problem with, or a question about, your subscription, you may phone us during regular business hours (Eastern time) at our toll-free number: 1-800-423-8912 (in N.J., 201-981-1963). You can also use Subscription Service to obtain back issues and editorial indexes.

PAID SERVICES

- ✓ **BIX:** BYTE's Information Exchange puts you on-line 24 hours a day with your peers via computer conferencing and electronic mail. All you need to sign up is a microcomputer, a modem, and telecomm software. For further information and cost call 1-800-227-BYTE.

- ✓ **Program Listings:** Listings of programs that accompany BYTE articles are now available on BIX, on disks or in quarterly printed supplements (see reply cards in this issue for cost information), or call 1-800-258-5485.
- ✓ **Microform:** BYTE is available in microform from University Microfilm International in the U.S. and Europe. See Contents page for cost information.

DISCOUNTS

- ✓ 13 issues instead of 12 if you send payment with subscription order.
- ✓ One-year subscription at \$22 (50% off cover price).
- ✓ Two-year subscription at \$40.
- ✓ Three-year subscription at \$58.
- ✓ One-year group subscription for ten or more at \$18.50 each. (Call or write for details.)

TOLL-FREE NUMBERS FOR YOUR CONVENIENCE:

Subscriptions & Back Issues:
1-800-423-8912 (in N.J.,
201-981-1963)

BIX: 1-800-227-BYTE

Program Listings Orders:
1-800-258-5485

*And . . . welcome to
BYTE country!*

BYTE
THE SMALL SYSTEMS JOURNAL



THE CASE OF EXEC AND THE TEMPORARY DOS EXIT

ibm.pc/software #2739, from nickbaran (Nick Baran, BYTE), Tue May 19 12:58:43 1987.

A lot of programs these days provide a function for temporarily exiting to DOS. My understanding is that when you exit to DOS, a new copy of COMMAND.COM is loaded into memory. When you exit DOS *back* to your program, you type "Exit" at the DOS prompt. So, here's the question. What is the specific function in DOS for performing this operation, and, is there a "programmer's" term for it?

ibm.pc/software #2740, from rduncan (Ray Duncan), Tue May 19 13:13:08 1987. A comment to message 2739.

There isn't a specific operation in DOS to provide a new command processor; it's just a special case of the EXEC function (Int 21h Fn 4Bh). Your program must look in the environment for the COMSPEC string to find the disk location of COMMAND.COM, and then feed that to EXEC (after making sure enough unowned memory is available in the system so that COMMAND.COM can run).

ibm.pc/software #2748, from condorwizard (Jim Morgan), Wed May 20 02:48:33 1987. A comment to message 2740.

While we are talking about the EXEC function, I notice that any changes to the environment are not maintained after you exit each copy of COMMAND. How can you maintain a new variable across command-processor loads? I'd like to let my software know that something happened out there and set some new parameter to pass back to the lower- (or higher-) level processor. When I

try it, it goes away with EXIT. Even when I put a dummy value in or change the dummy value to a real value, EXIT does not work.

ibm.pc/software #2749, from dmick, Wed May 20 03:09:33 1987. A comment to message 2748.

You can't. EXECing a program passes a copy of the environment, as Ray noted; EXITing the COMMAND.COM or terminating the child program loses the environment. There are ways to hunt for the "root" environment. . . take a look at tech.support/synopsis, somewhere in the first couple of messages, for one way. You can also look at the "snoop" code Ray Smith just uploaded recently (or will soon) or the MAPMEM.PAS module of the trsrc21.arc file for a clue as to how to locate COMMAND.COM and its environment (the first copy). This has to be the most common question on BIX, though, and it's all due to the half-usefulness of the environment under DOS.

Since I know it's a Unix feature, is there a way, oh Unix gods, to set the root environment from a child in that system?

ibm.pc/software #2750, from mjguz (Mark Guzdial), Wed May 20 09:00:37 1987. A comment to message 2749.

> set the root environment from a child in that system?

I took the Bell Labs shell programming course some time ago, and at least at that time, it was impossible. At least in the Bourne shell, all scoping is downward - you can change anything you want at a lower level, but everything bounces back to its original shape as you come back up.

continued

THE BEST MOST COST-EFFECTIVE STATISTICS PACKAGE AVAILABLE



Whether for industry, education, or pure research, no other statistics package can compare to Microstat when it comes to areas of coverage, accuracy, ease of use, and

value. In the past three years, Microstat has been requested by name on more military contracts than any other statistical package. Some of its features are:

- Data Management Subsystem for file creation and management.
- Data transformations (make new variables from old ones)
- Hypothesis Tests
- Three types of ANOVA
- Simple, Multiple, and Step-wise Regression (files can be larger than memory)
- 11 Nonparametric Tests
- Factorials, Permutations, and Combinations
- Interactive or Batch mode
- Can be run on floppy disk systems
- Read external files (e.g., Lotus, ASCII, dBaseII)
- Descriptive Statistics
- Scatterplots
- Correlation Analysis
- Time Series
- 8 Probability Distributions
- Crosstabs and Chi-Square
- Frequency Distributions
- User's Manual

1-800-952-0472 (orders)
1-317-255-6476 (info)

Microstat is available for MSDOS, PCDOS, CP/M80, and CP/M86. The price is \$375.00. Multiple copy discounts are available. To order call or write:

ECOSOFT INC.

6413 N. College Ave. ■ Indianapolis, IN 46220



InfoWorld		Unacceptable
Software Report Card		Poor
MICROSTAT	Functionality	Good
ECOSOFT	Documentation	Fair
	Ease of Use	Good
	Error Handling	Good
	Support	Excellent

InfoWorld, March 15, 1987

ECOSOFT



In the company cafeteria, a \$104,100 purchase is taking shape.

During lunch, electronics engineers, Bill Pearce and T.C. Patch, are discussing the pros and cons of various computer printers. Their final selections and purchases will range from pin-matrix to laser printers in order to satisfy a variety of requirements and environments throughout their company. Overall, Bill and T.C. are responsible for purchasing a new micro system worth \$513,616 for their company. The choice is theirs because they are experts in microcomputer technology, "Power Users" of computers at work and at home.

Bill and T.C. read *BYTE*, the magazine for "Power Readers," those computer pros who need in-depth technical knowledge about developments throughout the micro industry.

BYTE readers have real clout where they work. For example, during the next 12 months, *BYTE* subscribers with engineering titles like Bill's and T.C.'s will buy or influence their companies' average purchases of \$370,000 for micros and peripherals and \$143,616 for software. It's a fact... the *BYTE* reader is the "Power Buyer."

In terms of buying influence, our "Bill Pearce" and "T.C. Patch" typify average *BYTE* readers with engineering titles, according to the *1986 Hardware and 1987 Software Purchasing Influence Studies*.

Are you putting the "Power of *BYTE*" to work for your micro products? To find out how... call your *BYTE* Advertising Sales Consultant today.

BYTE means business.



BYTE

THE SMALL SYSTEMS JOURNAL

One Phoenix Mill Lane
Peterborough, NH 03458
(603) 924-9281



ibm.pc/software #2751, from rimorrisjr (Richard Morris), Wed May 20 13:10:28 1987. A comment to message 2750.

> Setting environment in Unix

Far as I know, that's right. Environment is singular. I suppose that a Supreme Kernel Hacker 3rd Class could track back through the PIDs of a process to find the root process.

ibm.pc/software #2752, from dmick, Wed May 20 15:56:57 1987. A comment to message 2751.

Well, at least it wasn't MS's boo-boo then. Seems like a universally accessible environment would be of more use.

ibm.pc/software #2753, from patwood (Patrick Wood), Wed May 20 17:53:39 1987. A comment to message 2752.

Unix, being a multiuser system, allows the environment to be changed for a user at log-in time via the .profile. This fixes only that user's environment for all his or her processes.

ibm.pc/software #2754, from dmick, Wed May 20 19:16:02 1987. A comment to message 2753.

Better than nothing, surely, but still it would be nice to have programmatic control of a system-reserved and system-used parameter area like the environment. A wonderful way to pass parameters that don't warrant file overhead.

ibm.pc/software #2741, from jlonie (Joseph Lonie), Tue May 19 16:21:03 1987. A comment to message 2739.

> Exiting to DOS. . .

This operation is often referred to as "shelling" to DOS. When you use Int 21h Fn 4Bh to load and run a second (or third, or fourth. . .) copy of COMMAND.COM, DOS in effect isolates you from the task you shelled from, giving you a *copy* of the environment area to play with. That is, the descendant COMMAND.COM task inherits the environment from the parent task; any changes the descendant task performs to the environment (e.g., via the SET command) affect only the descendant's copy, not the parent's copy. Rduncan's point on making sure there is enough free memory is very important if you're writing software that will provide a shell operation. Many older compiler/linkers (and some new ones!) put a word in the .EXE file header that instructs DOS that this task uses all available memory. DOS will believe this, whether it is true or not, and you will have to free up some memory via int 21h Fn 4Ah or you will trash the system-memory arena, as the Tech Ref puts it.

ibm.pc/software #2744, from dmick, Tue May 19 18:23:35 1987. A comment to message 2741.

Actually, you can't do an EXEC if you don't have the memory, I believe. Also, the .COM files use all available memory by default. You can do a direct shrink with .EXE files or use the MAXALLOC field (see the /CPARMAXALLOC option for the linker for more info).

ibm.pc/software #2758, from geary (Michael Geary), Thu May 21 05:14:36 1987. A comment to message 2739.

If you would like some sample code for the EXEC function, take a look at tech.support/long.messages #9 and #10. It's a MASM program that demonstrates using the EXEC function, both to run COMMAND.COM and to run other programs.

These names do get confusing - assembler types tend to call the function EXEC, but if you write some C code, don't try to use the execx() functions in the C library to do that - they do something else entirely! The C functions for this operation are called spawnxx(), where xx is different for the various flavors of the function. ■

Mini-AT Enclosure

Ideal for Plug-In AT CPU Boards.



Use with:
 • MICROMINT CCAT (OEM-286) Board (See "Circuit Cellar" Sept. '87)
 • SIGMA DESIGNS CPU 386 Board Set • And others

- Five 8/16 bit full-length expansion slots
- Three 1/2 height drive slots w/ drive mounting rails
- 100 Watt power supply w/ high surge capacity & fan
- Keyboard connector & cable
- Four serial/parallel connector punchouts
- Dimensions: 6.25" H x 11.75" W x 15.25" D
- \$239.00

DISKS PLUS, INC.
 356 Lexington Drive
 Buffalo Grove, IL 60089
 Telex: 650 249 2139 MCI UW
 Fax: (312) 537-8331

Technical and more info:
 (312) 537-7888
 To order:
 1 800 752-DISK

Registered: IBM PC, All International Business Machines Corp., CCAT and OEM-286, The Micromint, Inc., CPU 386, Sigma Designs, Inc.

DISKS PLUS
 Microcomputers & Peripherals

Also refer to our ad, page 272

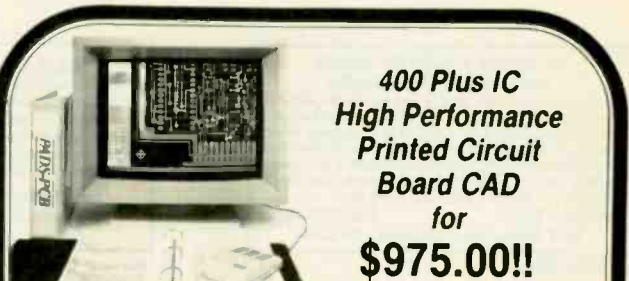

400 Plus IC High Performance Printed Circuit Board CAD for \$975.00!!

All the features of Engineering Workstation CAD, on XT, AT or 386 Personal Computers—and at an affordable price!

- Inputs from FutureNet™, Orcad™ and Schema™ and others
- Design-On-The-Fly at CRT without schematic input
- 1 mil database, 32" x 32" area, up to 30 layers & 250-400 IC's
- Automatic and Interactive Placement aids, including Dynamic Rubberbanding, Connection Length Minimization and Auto Part Swapping
- Interactive Routing on any grid from 1 mil upwards, i.e., 5, 10, 15, 20, 25, 50, etc.
- Thru, Blind and Buried Vias of Standard and Micro size.
- True width tracks and pads at the CRT.
- Fine Line Design-2 and 3 tracks between IC's. Track Segment thickening. Angles at 90, 45 and down to 1 degree.
- Auto Routing (optional)
- 2-D Documentation capability
- Full SMD and Analog Board design supported
- Plotting on matrix printer and ink plotter (Gerber Optional)
- Air Gap Checking
- TTL/CMOS Library included

PADS-PCB \$975.00

Additional options available

Evaluation Package of all Software on 3 Disks with Manual \$50.00

CAD Software, Inc.

P.O. Box 1142, Littleton, MA 01460 (617) 486-9521

THE BUYER'S MART

A Directory of Products and Services

THE BUYER'S MART is a monthly advertising section which enables readers to easily locate suppliers by product category. As a unique feature, each BUYER'S MART ad includes a Reader Service number to assist interested readers in requesting information from participating advertisers.

RATES: 1x—\$475 3x—\$450 6x—\$425 12x—\$375
Prepayment must accompany each insertion. VISA/MC Accepted.

AD FORMAT: Each ad will be designed and typeset by BYTE. Advertisers must

furnish typewritten copy. Ads can include headline (23 characters maximum), descriptive text (250 characters maximum), plus company name, address and telephone number. Do not send logos or camera-ready artwork.

DEADLINE: Ad copy is due 2 months prior to issue date. For example: October issue closes on August 1. Send your copy and payment to THE BUYER'S MART, BYTE magazine, 1 Phoenix Mill Lane, Peterborough, NH 03458. For more information call Mark Stone at BYTE 603-924-3754.

ACCESSORIES

FREE CATALOG

Thousands of parts and new surplus electronic parts at super low prices. FAST ORDER PROCESSING AND SHIPPING (95% of all orders shipped within 48 hours)

CALL OR WRITE FOR A FREE CATALOG.

ALL ELECTRONICS CORPORATION

POB 20406, Los Angeles, CA 90006-0406

1-800-826-5432

Inquiry 650.

ACCESSORIES

FREE CATALOG

Diskettes & Acc • Dust Covers • Furniture • Data Cartridges • Plotter Pens • Clean'g Supl • Tapes & Acc • Ribbons • Printers • Computer Paper • Copier Supplies • Surge Prot • Cables & Acc • Print Wheels • MUCH MORE!

Call, write or circle inquiry card for a FREE Catalog

GAAN COMPUTER SUPPLIES

186 B East Sunnyside, Campbell, CA 95008

(800) 523-1238, In Calif. (408) 370-6747

Inquiry 655.

BAR CODE

DATA INPUT DEVICES

Bar Code & Magnetic Stripe Readers for microcomputers & terminals, including IBM, DEC, AT&T, CT, Wyse, Wang. All readers connect on the keyboard cable & are transparent to all software. Low cost bar code print programs & magnetic encoders are also available. GSA approved.

TPS Electronics

4047 Transport, Palo Alto, CA 94303

415-856-6833 Telex 371-9097 TPS PLA

Inquiry 660.

SOFTWARE PACKAGING, DISKS

Cloth binders & slips like IBMs. Vinyl binders, boxes, and folders—many sizes. Disk pages, envelopes & labels. Low qty. imprinting. Bulk & branded disks. Much More! Low prices. Fast service. Call or write for FREE CATALOG.

Anthropomorphic Systems Limited

376-B East St. Charles Road
Lombard, IL 60148

1-800-DEAL-NOW (312) 629-5160

Inquiry 651.

BAR CODE

BAR CODE LABEL PRINTING

PrintBar II is a unique and powerful memory resident program that prints Code 39, 2 of 5 and UPC bar codes on Epson, IBM graphics and HP LaserJet printers. Print directly from any program including dBASE III, clipper, Lotus, Wordstar, without copying data to special print files. Superb documentation. \$295. PC compatible bar code readers \$395.

BEAR ROCK SOFTWARE CO.

6069 Enterprise Dr., Placerville, CA 95667(916) 622-4640

Inquiry 656.

IBM PC Labeling Software

Print Labels with Large Text and/or bar codes on PC with Epson/Okii/IBM LaserJet printers. Text to 1"x1" reads at 50 ft. Bar Codes: Code 39, 2 of 5, UPC/EAN, MIL-STD, ALAG. Flexible format/size, Reversals. File Input, Menu-driven \$279. Other menu-driven programs for bar codes \$49-\$129.

Worthington Data Solutions

417-A Ingalls St., Santa Cruz, CA 95060

(408) 458-9938

See our ad on page 193

AT LAST! A RIBBON INKER JUST FOR YOUR EPSON

Why buy new ribbons when you only use the ink? For just pennies each inking, this motorized inker provides perfect print quality. For any Epson compatible fabric ribbon. FREE 4 oz. bottle black ink, roller & cover. Epson Ribbon Inker \$52.95 Imagewriter I & II Inker \$49.00. Ship 24 Hr. Moneyback Guarantee. Check/M.O. Visa/MC. \$1.50 S&H. Ohio add 6.5% tax.

BEDE TECH 800-772-4536

8327 Clinton Rd., Cleveland, OH 44144

Inquiry 652.

BAR CODE DIRECTORY

The Automatic Identification Manufacturers and Services Directory contains over 350 listings from every major supplier of bar code products... companies that market complete bar code systems, scanners, printers, data collection terminals, film masters, labels, software, seminars and consultants. \$49.95

Helm Publishing

174 Concord St., Peterborough, New Hampshire

(603) 924-9631

Inquiry 657.

BAR CODE READERS

PC/XT/AT Bar Code Reader attaches as 2nd keyboard, reads bar codes as keyed data. One model converts to external mounting via velcro or slot mounting in PC — \$385. RS-232 Model—\$399. Rugged metal wand, reads UPC, EAN, 2 of 5, Code 39, etc. Same day ship. 1 year warranty. 30 day \$5 back guarantee.

Worthington Data Solutions

417-A Ingalls St., Santa Cruz, CA 95060

(408) 458-9938 See our ad on page 193

Self-Inking Printer Ribbon

For users of Okidata and other open spool ribbon printers. Controlled Printout Devices are a new kind of printing ribbon that re-ink themselves, and will last 15 times longer than the ribbon you are now using. For further information please call or write.

CONTROLLED PRINTOUT DEVICES, INC.

POB 869, Baldwin Rd., Arden, NC 28704

(704) 684-9044

Inquiry 653.

BAR CODE MADE EASY

PERCON® E Z READER™ keyboard interfaces and multuser RS-232 models make it easy to add bar code to virtually any computer/terminal WITHOUT SOFTWARE MODIFICATION. Immediate shipping. Two year warranty. Bar code printing software available. Call for details on fast, accurate, easy data entry. Substantial reseller discounts.

PERCON®

2190 W. 11th St., Eugene, OR 97402

(503) 344-1189

Inquiry 658.

BAR CODES/BIG TEXT FROM YOUR PROGRAM

Add bar codes and/or big graphics text to your program. Print from inside of dBASE, BASIC, C, any MS-DOS language or even a word processor. Bar codes: UPC-A, UPC-E, 2 of 5, and Code 39. Big text in wide and narrow sizes 5", 3" and 2" tall. Prints on Epson/Okii/IBM LaserJet printers \$179-\$239.

Worthington Data Solutions

417-A Ingalls St., Santa Cruz, CA 95060

(408) 458-9938

See our ad on page 193

COMPUTER PROTECTION

• UPS • LINE CONDITIONERS • ISOLATORS
• MODEM PROTECTORS
• AC POWER INTERRUPTERS
— HUNDREDS OF HINTS & PRODUCTS —

FREE CATALOG 1-800-225-4876

ELECTRONIC SPECIALISTS, INC.

171 So. Main St., POB 389, Natick, Mass 01760

1-800-225-4876

Inquiry 654.

READ & PRINT BAR CODES

Internal unit (short-card for IBM PC/XT/AT/compatibles) or RS-232 Dual Port unit; both work with all keyboards and software. Includes stainless steel wand or LASER gun. User-friendly Bar Code and Text printing software with format/size flexibility.

Seagull Scientific Systems

601 University Ave., Suite 150, Sacramento, CA 95825

(916) 386-1776

Inquiry 659.

BUSINESS OPPORTUNITIES

WANTED

Instrumentation consultants

in all parts of the U.S.

We want to refer potential clients to local consultants for PC-based instrumentation solutions.

Respond to:

P.O. Box 9565, New Haven, CT 06536.

Inquiry 661.

THE BUYER'S MART

BUSINESS OPPORTUNITIES

EATEN ANY GOOD CHIPS LATELY?

We eat, drink and sleep hardware and love describing the results. We're looking for others who have built unique projects and can write articles about them. If you've got a great project ready for a chapter in our book, write us now. We're already in the business and we pay top dollar!

Microservices

67 Scott Drive, South Windsor, CT 06074

Inquiry 662.

CAD/CAM

CADalyst™

FINALLY! — CAD Technology that compares with High-Tech Industry CAD systems. ONLY \$65.00!

• TEMPLATE • DIMENSIONING • LINE TYPING
• ROTATION • EPSON OR PROPRINTER PLOTTING
IBM PC or Compatible, 512K, mouse or joystick recommended IBM Color, EGA or Hercules graphics card required.
(800) 255-5604 MC/VISA (314) 346-4909

COMPUTER GRAPHICS RESEARCH
Rt. 1, Box 714, Camdenton, MO 65020

Inquiry 663.

LOGIC SIMULATION

Now you can have state of the art logic simulation for only \$98. Dynamic and static simulation with concurrent faults, propagation delay as a function of loading, knowledge based ATPG, interactive plotting, user friendly. (MADS vers. 4) IBM XT/AT

MICRO-ANALYTIC

2860 Hudson Ave., Corona, CA 91719
(714) 371-5703

Inquiry 664.

COMMUNICATIONS

3780RJE FOR PCs

Complete \$249 — Save over \$500

Talk to mainframes, minis, PCs
• Bisynd 2780/3780 word emulation • 19.2 Kbps thruput
• RJE card rd/punch, printer • PC-to-PC file transfer
Satisfaction Guaranteed. Call for prompt delivery.

1-800-523-8396, ext. 210
In CA 415-345-6666.

COD fr. prepaid, offer limited to stock on hand.
Intelligent Technologies
737 Lincoln Ctr. Dr., Foster City, CA 94044

Inquiry 665.

MULTI-USER BBS (FOR IBM PC AT)

TEAMate — a mainframe quality BBS. A mini CompuServe. Full screen cursor-controlled interface, topic outline structure, public and private topics, audit trails, xmodem, integrated mail, content retrieval and more. MS-DOS, XENIX and UNIX versions.

MMB Development Corporation

1021 No. Sepulveda Blvd., Suite K, Manhattan Beach, CA 90266
(213) 545-1455

Inquiry 666.

COMPUTER BOOKS

BORLAND

Osborne — McGraw Hill

COMPUTER BOOKS

• ADVANCED TURBO C 325 pgs. \$22.95 • TURBO PASCAL
Programmers Library 625 pgs. \$21.95 • USING TURBO C
350 pgs. \$19.95 • ADVANCED TURBO PROLOG Version 1.1
350 pgs. \$21.95

Add \$3.00 per book shipping. Check, Visa, MC, AX
FREE CATALOG ON COMPUTER BOOKS

MEDIA PUBLICATIONS (415) 968-3600
2166-B8 Old Middlefield Way, Mountain View CA 94043

Inquiry 667.

COMPUTER BOOKS

Computer Books Catalog

Attn: Computer Professionals! Order *The 1987 Prentice Hall Professional/Technical/Reference Catalog: Books for Computer Scientists, Computer/Electrical Engineers and Electronic Technicians* for only \$2.00 and receive \$5.00 off your first book purchased from this catalog!

Prentice Hall Publishers

College Marketing Dept., Englewood Cliffs, N.J. 07632
Attn: Mary Colt (201) 767-5937

Inquiry 668.

NEW COMPUTER BOOKS

Clipper Connection • *dBASE III/Clipper Prog. Guide*
• *dBASE III Plus: Things the Manual Didn't Tell You*
• *Working with MS-DOS* • *Working with SideKick*
• *The WordStar Handbook* • *Working with Pick*
• *Lisp Prog. Guide* • *Turbo Pascal Prog. Guide*
• *Excel: Using Macros* • *Catalogue Available*

WEBER SYSTEMS INC.

(800) 851-6818; orders only MC/VISA/AMEX
8437 Mayfield Road, Chesterland, OH 44026

Inquiry 669.

COMPUTER INSURANCE

COMPUTERS + INSURANCE = SAFEWARE
Call toll free for information

- LEASED COMPUTERS
- HOME COMPUTERS
- OVERSEAS COMPUTERS
- BUSINESS COMPUTERS
- COMPUTERS LEASED TO OTHERS
- COMPUTERS TAKEN TO SHOWS
- COMPUTERS HELD FOR SALE
- OTHERS' COMPUTERS IN YOUR CARE

SAFEWARE

The Insurance Agency Inc.
1-800-848-3469 IN OHIO (614) 262-0559

Inquiry 670.

CROSS ASSEMBLERS

WHY PAY MORE? THREE ASSEMBLERS FOR LESS THAN THE PRICE OF ONE

Quality cross assemblers for DOS computers. INTEL • ABSOLUTE HEX format or BINARY format file output. Complete error checking and reporting. Data string, offsets and equates capability. Multiple origins and data definitions. Each assembler comes complete with documentation and "showfile" utility.

disk #: 8080/8085 — 6800 — 6502

\$15.95 MN residents add 6% sales tax.

ANPRI SYSTEMS

P.O. Box 26036, St. Paul, MN 55126 (612) 347-1211
• INTEL is a trademark of INTEL CORPORATION
other assemblers available, call or write.

Inquiry 671.

CROSS ASSEMBLERS for VAX VMS and PC/MS DOS

Faster Version 2.1 Now Available
Relocatable Macro Cross Assemblers,
Linkers, Librarians
Targeted to almost all Microprocessors

ENERTEC, INC.

BOX 1312, Lansdale, PA 19446
215-362-0966 MC/VISA

Inquiry 672.

ASSEMBLERS & TRANSLATORS

Over 20 high quality, full function, fast relocatable and absolute macro assemblers are available immediately. Source language translators help you change microcomputers. Call for info about MS/DOS, CPM/80, ISIS versions.

RELMS™

P.O. Box 6719
San Jose, California 95150
(408) 265-5411
TWX 910-379-0014

Inquiry 673.

CUSTOM SOFTWARE

CUSTOM SOFTWARE

To your specifications!

Specializing In: BIT-slice microprogramming applications and design.

High-level: MS/DOS based 'C'.
Documentation: Other than well-commented listings is OPTIONAL for an additional fee.

E & J Enterprises, Inc.

P.O. Box 817, Henderson, Nevada 89015

Inquiry 674.

DATA CONVERSION

MEDIA CONVERSION/DATA TRANSLATION

More than just a straight dump or ASCII transfer!
Word Processing, DBMS, and Spreadsheet data on Disks or Tapes transferred directly into applications running on Mainframes, Minis, Micros. Dedicated Word Processors, Typesetters, and Electronic Publishing systems.
IBM PS/2 & Macintosh supported
#1 in the translation industry!

CompuData Translators, Inc.

3325 Wilshire Blvd., Suite 1202, Los Angeles, CA 90010
(213) 462-6222

Inquiry 675.

DATA/DISK CONVERSION

Disk/Disk • Tape/Disk • OCR

Over 1,000 formats! 3 1/2", 5 1/4", or 8 inch disks; 9 track mag tape; 10 MB Bernoulli cartridge. Data base and word processor translation. Specialists in Government Sensitive Data. Call for free consultation.

Computer Conversions, Inc.

We take the hassle out of data conversion...
9580 Black Mt. Rd., Ste J, San Diego, CA 92126
(619) 693-1697

Inquiry 676.

DISK CONVERSIONS

Media transfer to or from: IBM, Xerox, DEC, Wang, Lanier, CPT, Micom, NBI, CT, also WP, WS, MS/WRD, DW3, MM, Samna, DEC DX, MAS 11, Xerox-Writer, ASCII.

FREE TEST CONVERSION CONVERSION SPECIALISTS

531 Main St., Ste. 835, El Segundo, CA 90245
(213) 545-6551 (213) 322-6319

Inquiry 677.

DISK/DISK or TAPE/DISK CONVERSIONS — AUTOMATICALLY

Bought a new computer? Convert your data in just 1-2 days. **SAVE TIME • SAVE MONEY!**
DISK/DISK or TAPE/DISK Conversions start as low as \$15.00 for IBM, CPM, MS-DOS, UNIX, XENIX & most other systems. (Apple, Macintosh, Commodore conversions start at \$25.00). Call or write today for a cost saving quotation to fill your disk-to-disk or tape-to-disk data conversion needs.

CREATIVE DATA SERVICES

1210 W. Latimer Ave., Campbell, CA 95008
(408) 866-6080

Inquiry 678.

DISK AND TAPE CONVERSIONS

High quality conversion services & OCR scanning for Dedicated Word Processors, Mini and Micro computers. Over 1000 3 1/2", 5 1/4", and 8" formats, 800-1600BPI tape. Conversion between Wang, NBI, CPT, DEC, Vydec, Lanier, OS/6, Xerox, Linolex, Lexitron, MemoryWriter, Editwriter, CompEdit, Exxon 500, Exxon Qyx, IBM Sys/34/36/38/55/20, MAC, Victor, TRS, Apple II & III, NSTAR, IBM PC/AT/3 1/2", HP, and most other Micros. Conversion directly into word processing software such as DW3, WP, MS/WRD, WS, Samna, MM, PFS, & many others.

DATA FORMATS, INC. (408) 629-1088

Inquiry 679.

THE BUYER'S MART

DATA/DISK CONVERSION

IBM PC \leftrightarrow to \leftrightarrow HP

IBM PC to HP File Copy allows IBM PCs and compatibles to read and write files written by Hewlett Packard Series 70, 80, 200, 300, 1000, 9000 computers. Call for information on this and other HP file copy programs and program translators.

Oswego Software 312/554-3567
507 North Adams St. Fax 312/554-3573
Oswego, Illinois 60543 Telex 858-757

Inquiry 680.

CONVERSION SERVICES

Convert any 9 track magnetic tape to or from over 800 formats including 3 1/2", 5 1/4", 8" disk formats & word processors. Disk to disk conversions also available. Call for more info. Introducing OCR Scanning Services.

Pivar Computing Services, Inc.
165 Arlington Hgts. Rd., Dept. #B
Buffalo Grove, IL 60089 (312) 459-6010

Inquiry 681.

dBASE III COMPILERS

FREE dBASE III + COMPILER DEMO DISK

Don't buy Clipper™ until you see our FREE dBASE Compiler Evaluation Kit. Includes DEMO DISK with 8 PRG's and results of compiling with Clipper, Quicksilver & FoxBASE+. Also 15 benchmark tests, complete magazine reviews, and detailed brochures about all 3 compilers FREE. No obligation. Call 24 hours, 7 days.

dataBASE Specialties (415) 652-2790
P.O. Box 2975, Oakland, CA 94618

Inquiry 682.

DEMOS/TUTORIALS

INSTANT REPLAY II

Build Demos, Tutorials, Prototypes, Presentations, Music, Timed Keyboard Macros, and Menu Systems. Includes Screen Maker, Keystroke/Time Editor, Program Memorizer, and Animator. Rec'd Great Reviews! Simply the BEST! Not copy protected. No royalties. 60 day satisfaction money back guar. IBM and Compatib. \$149.95 U.S. Chk/Cr. Crd. Demo Diskette \$5.00.

NOSTRADAMUS, INC.
3191 South Valley Street (ste 252)
Salt Lake City, Utah 84109 (801) 487-9662

Inquiry 683.

DESKTOP PUBLISHING

RED PENCIL

The only PC markup and correction program for document editing/review cycles. Make editing marks and comments, set text, all on-screen. Automatic update. Save on typesetting, proofreading. Requires IBM PC 128K, CGA, composite or RGB monitor, 2 drives. \$199.

Capsule Codeworks
9024 132nd Place SE, Renton, WA 98056
(206) 235-7099

Inquiry 684.

QMS KISSLASER + W/TWO MEGABYTES \$2,575
CANNON IX-12 SCANNER \$795
JLASER + AT 2MB \$799
VENTURA PUBLISHER FROM XEROX \$569

THE RAM EXPLOSION (703) 941-9006
"We also carry a complete line of MEGAMEMORY BOARDS."
5119A Leesburg Pike, Suite 260, Falls Church, VA 22041
Dealer Inquiries Invited
VISA/Mastercard An Authorized Tall Tree Dealer

Inquiry 685.

DUPLICATION SERVICES

SOFTWARE DUPLICATION

- One Stop Shopping • Technical Support
- Custom Packaging • Drop Shipping
- Copy Protection • Fast Turnaround
- Competitive Pricing

SATISFACTION GUARANTEED
800-222-0490 NJ 201-462-7628

MEGASoft

P.O. Box 710, Freehold, NJ 07728

BLANKET SERVICES

Diskette duplication • Packaging • Stocking/Drop shipping • 48 hour delivery • SUPERLOK copy protection • No mastering fee • No charge for standard labels •

Star-Byte, Inc.

713 W. Main St., Lansdale, PA 19446
215-368-1200 800-243-1515

Inquiry 686.

ENTERTAINMENT

NFL CHALLENGE UPDATE

PROROSTR™ increases the realism of your NFL Challenge game by providing you with an easy way to update player data files. Prints a formatted printout of the player names and data. Includes PRODATA™ the complete 1985 player roster and statistics. Requires IBM type NFL CHALLENGE (copyright XOR Corp.). PROROSTR \$32 ppd. PRODATA may be purchased separately \$22 ppd. Check, MO, MC, VISA

HD&S Software

Box 924183, Houston TX 77292
(713) 688-9102

Inquiry 687.

LOTTO NUMBER ANALYZER

Use your PC to help you win the Lotto. This fun-to-use program for most home computers will quickly tell you which numbers are "due" any patterns and trends, what groups to play and more! Make your selections based on the laws of probability and INCREASE your chances of winning! Only \$24.95 + \$2 s/h.

SOFT-BYTE COMPUTER PROGRAMS

P.O. Box 556, Dayton, OH 45405
(513) 233-2200

Inquiry 688.

USE YOUR PC TO PLAY LOTTO!

Increase your chances of winning big! LOTTO-LUCK is a computer program, designed by a computer scientist using the latest techniques of Geometrical, Kabalism and Random Relationships of numbers to give you an opportunity to predict possible winning PICK/6 lotto numbers. LOTTO-LUCK will work on any lottery, in any state or country. Runs on IBM PC, C-64 and Apple II. Send \$29.95 + \$3 S/H to:

WIN\$WARE SYSTEMS

P.O. Box 8130 H, Sacramento, CA 95818
(916) 457-5535

Inquiry 689.

FLOW CHARTS

FLOW CHARTING II+ HELPS YOU!

Precise flowcharting is fast and simple with Flow Charting II+. Draw, edit and print perfect charts: bold and normal fonts, 24 shapes—95 sizes; fast entry of arrows, bypasses & connectors; Fast Insert Line; shrink screen displays 200-column chart; 40 column edit screen for detail work, much more!

PATTON & PATTON

81 Great Oaks Blvd., San Jose, CA 95119
1-800/672-3470, ext. 897 (CA residents)
1-800/538-8157, ext. 897 (Outside CA)
408/629-5044 (Outside the U.S.A.)

Inquiry 690.

FLOW CHARTS

STRUCTURED FLOW CHART

NSChart creates Nassi-Shneiderman (structured) flowcharts from a simple PDL. Keywords define structures & text strings appear in the chart. Easy to create, even easier to revise! Automatic chart sizing, text centering. Translators from many languages available. For Mac and IBM PC.

SILTRONIX, INC.

P.O. Box 82544, San Diego, CA 92138

1-800-637-4888

Inquiry 691.

HARD DISKS

BYTE SPECIAL !! Avg. 60MB for \$599

An ST 251 with our special software installed yields about 60MB, average. Our special Hard Disk Solution Series software can also speed your system up dramatically (50% or more) and protects you from data loss. Plain ST 251 40MB drive—\$499!! Ask about other drive models.

Call us now at 1-800-MEG-5001
In Florida 813-461-2011
MEGAMEDIA INTERNATIONAL
1479 S. Greenwood Ave., Suite A, Clearwater, FL 33516

Inquiry 692.

HARDWARE

68020 SUPER MICROCOMPUTERS

Up to 14.5 Mbyte RAM, 256K ROM, 34 users, floppy and hard drive (SCSI) w/DMA, calendar/clock w/bat. backup, timer, real time, multi-tasking, multi-user Professional OS-9™ op. sys. w/BASIC 09™, "C" compiler, assembler, screen editor, linking loader, utilities. Fits PC type cabinets. Mem. prod. & graphics options, more. From \$2195.00.

Other 68XXX computer systems from \$995.00.
AAA Chicago Computer Center
120 Chestnut Lane - Wheeling, IL 60090
(312) 459-0450

Inquiry 693.

ANDY'S COMPUTERS

PO Box 6096, Austin, TX 78762
1 (800) 521-2283 for ordering
1 (512) 478-9803 for info
Prices include Amber Monitor (TTL), 640K M/B, 256K Installed Case, Power Supply, Keyboard, Printer, Port, Disk Turbo XT 4.77BMZ \$500 AT 286 Mini 6.12 \$964
AT 286 610MZ \$958 386 16MZ \$2775
Hard Disks Add: 20 MEG \$330
Portable XT \$749 Portable XT \$759
Portable AT \$1190 Portable 386 \$3200
Other equipment and configurations available at similar savings.

Inquiry 694.

INDUSTRIAL COMPUTERS

68008-68020, STD Bus I/O

OS9 PRO op. sys., STD Bus and single board CPUs, SCSI, VME I/O channel, ARCNET interface to STD Bus I/O, ROM and Disk systems. Programming and hardware design services. Code conversion 680x, Z80, 8085 to 68000. Specialists in meeting industrial I/O requirements.

Bill West Inc.

Box 4347, Stamford, CT 06907
203/322-4033

Inquiry 695.

DIGITAL SIGNAL PROCESSOR

The Model 10 for the IBM PC/XT/AT is based on the TI TMS32010 and is designed for applications in communications, instrumentation, speech, and numeric processing. A 1K complex FFT takes 90 ms. Offered with 12 bit 80 KHz A/D and D/A and continuous data acquisition & playback option, \$650 and up.

DALANCO SPRY

Suite 241, 2900 Connecticut Ave. NW,
Washington DC 20008
(202) 232-7999

Inquiry 696.

THE BUYER'S MART

HARDWARE

CHIP CHECKER

- 74/54 TTL + CMOS • 8000 Nat. + Signetics
- 14/4000 CMOS • 9000 TTL
- 14-24 Pin Chips • 3" + .6" IC widths

Tests/Identifies over 650 digital chips with ANY type of output in seconds. Also tests popular RAM chips IBM compatible version \$259. C128 + C64 version \$159.

DUNE SYSTEMS

2603 Willa Dr., St. Joseph, MI 49085

(616) 983-2352

Inquiry 697.

SINGLE BOARD SOLUTION

Industrial strength computer has optimum features for monitor + control applications: 16 Chan A/D 8 Opto INs 8 Hi Drive OUTs RS232 Port Timer 5.25 x 8.0. Options: Resident FORTH 79 OS with Target Compiler, Editor, Assembler + Auto Load/Start; 5 MHz 8085 Battery Backed RAM/Clock *Expansion Boards *IBM/CPM Support

E-PAC 1000 \$229. E-PAC 2000 \$399

EMAC INC.

PO Box 2042, Carbondale IL 62902

(618) 529-4525

Inquiry 698.

IBM CLONES — NOT STRIPPED

80386 w/512K RAM, 60 MB, 25 MS hard disk, 1.2 MB floppy, EGA, monitor, clock, parallel & serial ports ... \$4,495

XT w/20 MB hard disk, floppy, graphics, monitor, 640K RAM, clock, parallel & serial ports ... \$1,095

JKL

717 Ellsworth Dr.
Silver Spring, MD 20910

301-587-3232 1-800-JK3-0386

No charge for credit cards.

Inquiry 699.

POWERLINE GREMLINS?? POWER FAILURES??

The MEIRICK STANDBY POWER SYSTEM is the TOTAL SOLUTION to your powerline problems.

400 watt system - \$449;
800 watt system - \$795

MEIRICK Inc., POWER SYSTEMS DIV.

Box 298, Frisco, CO 80443 303-668-3251

Inquiry 700.

ADDCARD PUTS 8 SLOTS IN THE 5 SLOT IBM-PC FOR ONLY \$79.00.

Fits inside system • 100% IBM Compatible • Uses existing motherboard • Accepts many boards including Turbo, RAM, tape backup, modem, floppy or hard disk controllers & others, • Visa/MC/COD • Call or write for orders or brochure:
1-800-231-4310 Ext. 768 / 313-562-9768

Merak Ind. • 8704 Edna • Warren MI 48093

Inquiry 701.

PC WHOLESALE CENTER

Hyundai TTL Amber Monitor \$ 72.00
Hyundai TTL Green Monitor \$ 70.00
AT Compatible Bare Bone System (10 MHz) \$490.00
Motherboard, Case, 200W Power Supply
XT Compatible Bare Bone System (8 MHz) \$170.00
Motherboard, Case, 150W Power Supply
MGP Card—\$ 46.00 Mult II—\$ 56.00

SANFORD SYSTEM INC.

10413 Rockley Rd., Houston, TX 77099

(713) 879-0068

Inquiry 702.

HARDWARE

NEW/USED APPLES & STUFF

MACINTOSH \$800. + up

Imagewriters I & II \$275

Apple II+ & IIE — Call

Mac accessories—hard drives Call
We buy, sell & horse-trade — Apple, IBM.

SHREVE SYSTEMS

845 Lark Ave., Shreveport, LA 71105

318-865-6743 4-9 p.m. C.S.T. VISA/MC

Inquiry 703.

SANYO 550/555 USERS

TURBO BOARD 7.2 MHZ \$ 89.95
20 MEG EXTERNAL HARD DISK SYSTEM \$599.00
VIDEO BOARD \$149.95
RS-232 BD. \$ 39.95
HARD DISK CONT W/CABLES & SOFT (ST-506) \$139.95
768K MEM. CLK. & EXPANSION BD.
(FREE RAMDISK, SPOOLER, & SOFTVIDEO-RUNS
IBM PROGRAMS) \$189.95

TAMPA BAY DIGITAL

1807 Gulf-to-Bay Blvd., Clearwater, FL 33575

813-443-7049

Inquiry 704.

Advanced DYNAMIC SPEED CONTROL 1.25MHz AT Clone

Doesn't simply increase frequency, offers AUTO speed switching between 8 & 12.5MHz. Avoids any down caused by add-on cards designed to run at the standard 8MHz. Delivers very impressive performance but problem free from 12.5MHz.
TEC286-12 80286, DSC 12.5/8 or fixed 12.5 settable 1M RAM, PHOENIX BIOS, TOD clock/calendar w/bat, FDHD controller, 1.2M FD metal case, keyboard, 200wps
TEC286-12 + Mono Graphic w/Printer Port + Hi-res Monitor \$1450
TEC286-12 + EGA w/printer port (256K) + EGA Hi-res monitor \$1898
Other Config System and parts Call
One Year Limited warranty 30-day satisfaction guarantee.

TEXAS EXPRESS COMPUTER

11802 Charing Clock Rd., Austin, TX 78759 (512) 258-4607

Inquiry 705.

USA WHOLESALE

1200/2400	EVEREX MODEM	\$89/\$189
EMS/EGA	EVEREX CARDS	\$99/\$159
SERIAL/BUSS	LOGITECH MOUSE	\$72/\$89
20MB/30MB	HARD DRIVE KIT	\$299/\$359
3.2/6MHz/8MHz	DOS/8087	\$75/\$99/\$139
6/8/10/MHZ	80287	\$159/\$239/\$289

214-418-0017

P.O. Box 819058-590, Dallas, Texas 75381

Inquiry 706.

HARDWARE/ADD-ONS

APPLE COMPATIBLE 1 MEG RAM BOARDS!

One Year Warranty! Other Products Available!

1 Meg/80 Col Board, w/256K & SFWR (Ile) \$99.
1 Meg RAM Board for IIGS w/256K \$88.
Cooling Fans (IIGS \$25) (II+Ile \$29)
A/B Switchbox Parallel or RS-232 \$29.

Add \$3 Shipping, COD + \$2. MC/VISA OK.
UNIVERSITY & SCHOOL PQ's WELCOME!

NEXO DISTRIBUTION (619) 589-7928

914 East 8th St., Ste. 109, National City, CA 92050
Monday - Friday, 10 a.m. - 6 p.m.

Inquiry 707.

Z80™ / HD64180/CP/M™ CO-PROCESSORS

Plug-In co-processors for PC, PC/AT.

Blue Thunder Z80 co-processors

6 MHz \$249.95 10 MHz \$399.95

12.5 MHz \$599.95

HD64180 co-processors \$295 and up

All co-processors with CP/M emulator. Software only

emulator ZS-12M only \$99.95.

Z-WORLD 408-980-1678

2065 Martin Ave. #110, Santa Clara, CA 95050

See Ad Page 370.

Inquiry 708.

HARDWARE/COPROCESSOR

PC MINI-SUPERCOMPUTER

Up to 36 MIPS In Your PCI

Fit your PC/XT/AT with 1 to 6 PC4000 boards for a high speed PC/RISC system. The PC4000 uses the NC4016 RISC Engine which executes high level Forth in silicon. Each PC4000 is a general purpose parallel coprocessor that delivers speeds in the 5 to 7 MIPS range... over a 100 times faster than a PC, K & R standard C and Forth available. From \$1295

SILICON COMPOSERS (415) 322-8763

210 California Ave., Suite 1, Palo Alto, CA 94306

Inquiry 709.

HARDWARE/PERIPHERALS

GM CAR COMPUTER READ-out

- Read engine computer data
Is sensor data reasonable?

Are status switches set?

Are any trouble codes set?

- Make disk records of car packets
- Let your PC be automotive.

EXECUTIVE ELECTRONICS, INC.

938 Main St., Dept. B, Yarmouthport, MA 02675

(617) 362-3694

Inquiry 710.

INVESTMENT

CAPTOOL!™ \$59

Multiple portfolio manager. Stocks, bonds, funds, dpr. assets. True ROI before/after taxes. DJ/Com-
puserve pricing. Batch & client features. Stock & bond evaluators. Beats all others! IBM PC or PS/2.
\$3 S&H. Chk/VISA/MC.

TECHSERVE inc.

P.O. Box 70056, Bellevue, WA 98007

800-826-8082 or 206-747-5598

Inquiry 711.

LAND SURVEY

L-PLOT

L-PLOT... A Metes & Bounds program to plot/print plats of Any scale—Any description—use Any measurement! Calc. areas, error of closure, plots multi tracts. IBM/compat with monographics, CGA or EGA capability. \$190. \$15 working demo. Visa/MC/Chk.

LAN/SCAN, INC.

P.O. Box 6863, Abilene, TX 79608

(214) 824-6419

Inquiry 712.

LAPTOP COMPUTERS

LAP-LINK

The ultimate solution for linking laptop computer with any IBM compatible desktop PC. 115, 200 baud transfer rate—faster than any other product available. No installation necessary, easy to use split screen design. Includes incredible "universal cable" that connects any two computers. Transfer entire disks faster than a DOS copy command! Only \$129.95 including universal cable and both 3 1/2" and 5 1/4" disks. "Bridge" owners can trade in for only \$89.95 w/o cable.

Traveling Software, Inc.

19310 North Creek Parkway, Bothell WA 98011

1-800-343-8080 (206) 483-8088

Inquiry 713.

MAILING LIST PROGRAMS

Professional List Management

ArcList — mainframe mailing list management for the XT/AT/386. Capacity 20 million names, automatic zip and state verification, print any label, custom charts and reports, merge-purge with excellent near-dupe recognition, match codes, postal presorting of all classes of mail, Nitn sampling, much more \$595. Save thousands of dollars. Call for free 16 page booklet.

Arc Tangent, Inc.

923 Olive St., POB 2009, Santa Barbara, CA 93120

800-843-5928 (In CA. 805-965-7277)

Inquiry 714.

THE BUYER'S MART

NETWORKING

Multiple Users Under PC DOS

PC-MOS/386 and Multilink Advanced turn DOS into a powerful multiuser O/S. Connect inexpensive CRT terminals to serial ports on XT/AT/386.

- Complete line multiuser hardware/software
- Custom system configurations available.

Call Today for Free Consultation

201-222-6363

DATATRUST

379 Westwood Ave., Long Branch, NJ 07740

Inquiry 715.

PROGRAMMER'S TOOLS

Modula-2

REPERTOIRE is an integrated DBMS, window/forms/menu generator, multi-window text editor, and expression evaluator designed specifically for M2. Only \$89 with full (600K) source code and 320p printed manual. Complete manual for this and many other M2 tools available on free demo disk. MC/VISA/AMEX/POC/D.

PMI 4536 SE 50th, Portland, OR 97206
(503) 777-8844; BIX: pmi

Inquiry 716.

FREE PRICE GUIDE

Call or write for our FREE comprehensive price guide containing hundreds of languages, utilities and books specifically for IBM personal computers and compatibles. We're the world's leading independent dealer of programmer's development tools because we provide sound advice, low discount prices, fast delivery, FREE U.S.A. shipping and no hidden charges.

Programmer's Connection 800-336-1166 USA
216-877-3781 OH & AK (Collect) 216-877-3781 OH & AK (Int'l)
136 Sunnyside St. 800-225-1166 Canada
Hartville, OH 44632 9102406879 Telex

Inquiry 717.

DO YOU WRITE SOFTWARE?

EZ-INSTALL helps you CLEANLY distribute software applications or products to users! Get control—stop messing with .BAT files. Check available disk, memory, file sizes, time stamps, drives, directories, DOS versions, etc. "Bullet-proof" installation routines can be yours! Only \$99! (M/C, VISA).

The Software Factory, Inc.
15301 Dallas Pkwy, LB 44, Dallas, TX 75248
(214) 490-0835

Inquiry 718.

PUBLIC DOMAIN

\$3 SOFTWARE FOR IBM PC

Public Domain & User Supported Software. Hundreds to choose from, wordprocessors, data bases, spreadsheets, assorted games for all ages, communications, business, music, art, programming language and useful utilities for making your computer easier to learn. Most programs have documentation on the disk. Write for your FREE catalog today!

BEST BITS & BYTES

P.O. Box 5332, Dept B, North Hollywood, CA 91616
(818) 893-6304

Inquiry 719.

PUBLIC DOMAIN SOFTWARE

Over 3000 disks covering PC/MOS-Dos, CP/M, Macintosh, Atari and Amiga. Priced from \$6/disk by mail or download by modem from our 19 remote systems. (300-9600 baud. 600+ Megabytes online) for flat annual charge of \$50 (US). Fast service, shipped around the world. Call or circle inquiry #720 for our FREE 40 page minicatalog of highlights.

CANADA REMOTE SYSTEMS LIMITED
(1-416-231-2383)

Inquiry 720.

340 B Y T E • SEPTEMBER 1987

PUBLIC DOMAIN

RENT SOFTWARE \$1/DISK

Rent Public Domain and User Supported Software for \$1 per diskfull or we'll copy. IBM, Apple, C-64, Sanyo 550 and Mac. Sampler \$5. VISA/MC. 24 hr. Info/order line. (619) 941-3244 or send #10 SASE (specify computer) Money Back Guarantee!

FutureSystems

Box 3040 (T), Vista, CA 92083
office: 10-6 PST Mon.-Sat. (619) 941-9761

Inquiry 721.

SALES/MARKETING TOOLS

SALES MAGIC

Software solutions for better selling from **MARKET POWER INC.**

computer Innovations

We are proud to have helped these companies: Navistar, Westinghouse, Kodak, Chemical Bank, Chrysler, Canadian National Hotels, and more...

Whether you are a company or an individual, we can help you. Call or write. **(916) 432-1200**

101 Providence Mine Rd., Suite 106 A FREE
Nevada City • California 95959 DEMO DISK

Inquiry 722.

SOFTWARE/ACCOUNTING

dBASE BUSINESS TOOLS

- * General Ledger
- * Accounts Recvbl.
- * Order Entry
- * Sales Analysis
- * Purch Ord/Inventory
- * Accounts Payable
- * Job Costing
- * Job Estimating

\$99 EA + s&h w/dBASE 2, 3 or 3+ SOURCE CODE

dATAMER SYSTEMS Cr. Crd/Chk/COD
4876-B Santa Monica Ave.
San Diego, CA 92107 (619) 223-3344

Inquiry 723.

SOFTWARE/A.I.

NEW INTEGRATED ENVIRONMENT AI FOR THE IBM PC

TOPS! IS A FULL VERSION OF OPSS WHICH RUNS UNDER MS-DOS, UNIX OR CP/M. A FAST, EFFICIENT EXPERT SYSTEM DEVELOPMENT TOOL.

PROTOTYPING: \$125 PRODUCTION: \$250
PROFESSIONAL: \$375 SHIPPING: ADD \$5

DYNAMIC MASTER SYSTEMS

POB 566456, Atlanta, GA 30356
(404) 565-0771 Telex #282923

Inquiry 724.

SOFTWARE/BASIC

CUT 80% CODE & HASSLE

- 1) Utilities to manage reliably screens, menus, times, files (Isam, Vasm, HCode).
- 2) Complete BASIC library to use them easily. With EPI-Tools, you are the only one at the helm. Only \$69 (introductory offer) — Money back guarantee. Visa/MC/AmEx/MO/Chk — \$4 Demo disk — Free details.

Alexis RIGO & associates (E.P.I.)

USA EUROPE
13607 Runney Meade Dr. Rue de l'Echelle, 253
Sugar Land, TX 77478 B4100 SERAING BELGIUM
(713) 242-6371 Telex (046) 42037 lpcmb

Inquiry 725.

COMPILED BASIC TOOLS

We now carry a complete line of libraries and tools for Compiled BASIC in addition to our FINALLY! series. Get our catalog of top brand products for Compiled BASIC, by calling 1-800-423-3400 (9:00 AM to 8:00 PM EST)

KOMPUTERWERK, INC.

851 Parkview Blvd., Pittsburgh, PA 15215
PA & AK call (412) 782-0384

Inquiry 726.

SOFTWARE/BUSINESS

DATA ENTRY SYSTEM

Heads down data entry with two-pass verification for the PC/XT/AT & compatibles. Loaded with features like: Auto dup & skip, verify bypass, range checks, & table lookups. Fully menu driven only \$395. Call for free 30 day trial period.

COMPUTER KEYS

21929 Makah Rd., Woodway, WA 98020
(206) 776-6443

Inquiry 727.

TSA88-TRANSPORTATION

A general-purpose system for solving transportation, assignment and transhipment problems. Solves transportation problems with up to 510 origins and/or destinations by applying the Transportation Simplex Algorithm. Menu-driven with features similar to LP88. Requires 192K, \$149 with 8087 support user's guide. VISA/MC.

EASTERN SOFTWARE PRODUCTS, INC.
P.O. Box 15328, Alexandria, VA 22309
(703) 360-7600

Inquiry 728.

dFELLER Inventory

Business Inventory programs written in modifiable dBASE source code.

dFELLER Inventory \$150.00

Requires dBASE II or III, PC-DOS/CPM

dFELLER Plus \$200.00

with History and Purchase Orders

Requires dBASE III or dBASE III Plus (For Stockrooms)

Feller Associates

550 CR PPA, Route 3, Ishpeming, MI 49849
(906) 486-6024

Inquiry 729.

Smith's Text Checker

Express your ideas clearly and more forcefully with Smith's Text Checker. Business people, engineers, and students need it to improve their reports, letters, and memos. For the IBM PC with 128K & disk drive. Not copy protected. \$20 ppd; checks OK.

SMITH CONSULTING

Route 1 Box 213, Greensburg, IN 47240
(812) 663-7470

Inquiry 730.

SOFTWARE/CHURCH

PowerChurch Plus™

Fast, friendly, reliable church administration system. Full fund accounting, mailing lists, membership, contributions, attendance, word processing, accts. payable, payroll, multi-user support, and much more - all for \$495 complete. Demo version, \$10

F1 SOFTWARE

P.O. Box 3096, Beverly Hills, CA 90212
(213) 854-0865

Inquiry 731.

ROMAR CHURCH SYSTEMS™

Membership-61 fields plus alternate address; labels, letters, reports any field(s). Offering-256 funds; optional pledge; statements; post to 255 y/year. Finance-G/L with budget; up to 500 sub-totals & 99 depts; month & YTD reports anytime for any month. Size 2000 people/flop-py. 25000/10 meg. Ad too short! Write!

Romar Church Systems, Attn: BMB

P.O. Box 4211, Elkhart, IN 46514
(219) 262-2188

Inquiry 732.

THE BUYER'S MART

SFTW./COMMUNICATION

SPECIAL BBS OFFER FOR IBM
IDEA-TREE Multi-topic system. Public/private msg. areas, file transfer, Xmodem, database, more \$99
PC-DATE Matchmaking system. Modifiable questionnaire, public/private msgs., pref. screening \$79
BAUDCAST Message distributor for announcements, news or any text to remote receiving stations \$59

ProtoSoft
 P.O. Box 16756, Seattle, WA 98116
 (206) 932-5310 (voice) or (206) 932-7125 (BBS)
 VISA/MC

Inquiry 733.

SOFTWARE/EDUCATION

THE GMAT COURSE (PC/XT/AT)
 Covers every type of exam question with instant feedback, solutions, timed tests, personalized score analyses, math and grammar reviews. All material is on the screen. Designed by MBA's, the program has improved students' scores by as much as 250 pts. Includes 5 disks + manual. \$59.95

COMWELL SYSTEMS, INC.
 P.O. Box 41852, Phoenix, AZ 85080
 (info & orders) (602) 869-0412
 (orders only) (800) 255-2789

Inquiry 734.

SOFTWARE/ENGINEERING

Affordable Engineering Software
 CALL OR WRITE FOR FREE CATALOG
 Circuit Analysis • Root Locus • Thermal Analysis • Plotter Drivers • Graphics • Signal Processing • Filter Design • Report Proof-reader • Transfer Function Analysis • PC/MSDOS • Macintosh • CP/M. VISA/MC.

BV Engineering • (714) 781-0252
 2200 Business Way Suite 207, Riverside, CA 92501

Inquiry 735.

Engineer's Aide

Join the Desktop Engineering Revolution!

- Pipeline/Ductwork Sizing
- Office/Control Valve Sizing
- Pump/Fan/Compr. Sizing
- Project Financial Analysis
- Heat Exchanger Sizing
- Conversion Calculator
- Fluid Properties Library
- Specification Writer

Above programs in one stand alone integrated package for \$695. For IBM PC & Macintosh.
Engineering Programming Concepts
 1-800-367-3585 (24 hr) 1-805-484-5381 (Ca)

Inquiry 736.

TIMEPLOT

Save hours! Draw, edit and print timing diagrams having 32 logic "signals" or time waveforms on a color IBM computer and Epson/IBM printer.
 \$39.50 ea. / 5+ @ \$33.00 ea. / 10+ @ \$27.50 ea.
 add 6% in NJ / \$3 per order outside US and Canada

CHK/MO/no PO's

Kenneth Curtis
 Box 539 RD2 Woodland Drive, Califon, NJ 07830

Inquiry 737.

Scientific Plotting Pkg.

Engineers/scientists prepare publication quality plots with F-CURVE. A few of F-CURVE's features: Plot-data, smooth curve through data, regression curves (linear or nonlinear). Draw linear, log, inverse, or power axis. Label plot. You have total control. For MS-DOS and HP Plotters.

\$59.95 VISA/MC/check

LEDS Publishing Co., Inc.
 P.O. Box 12847, Research Triangle Park, NC 27709
 (919) 477-3690

Inquiry 738.

SOFTWARE/ENGINEERING

Engineering/Scientific Journal
ACCESS is the only journal devoted to meeting the needs of engineers/scientists using microcomputers. If you are interested in numerical analysis, statistics, modeling, expert systems, or other technical applications, subscribe to ACCESS. \$21/yr.
 VISA/MC/check.

LEDS Publishing Co., Inc.
 P.O. Box 12847, Research Triangle Park, NC 27709
 (919) 477-3690

Inquiry 739.

Servo Design with CCAP

Powerful stability analysis tool for XT, AT and compatibles. High Res Bode, Nichols, Nyquist and root locus plots. Build and solve system models using up to 50 equations. S-plane, Z-plane and W-plane. Interactive transfer function databases. Menu-driven user interface. Analyze 60th order transfer functions. Read NASTRAN modal output to include mechanical resonances in model.

Lewis Engineering Software
 P.O. Box 55-BV, Andover, MA 01810
 (617) 975-5509

Inquiry 740.

FINITE ELEMENT ANALYSIS

MSC, the leader in FEA technology, markets a full line of FEA tools for personal computers. Starting at \$45 for MSC/pal INTRO on either the IBM PC or the Apple Macintosh, our products are designed to be complete and easy to use. Interfaces for most CAD systems available.

The MacNeal-Schwendler Corporation
 815 Colorado Blvd., Los Angeles, California 90041
 (213) 259-3888

Inquiry 741.

SIMULATION WITH GPSS/PC™

GPSS/PC™ is an IBM personal computer implementation of the popular mainframe simulation language GPSS. Graphics, animation and an extremely interactive environment allow a totally new view of your simulations. Simulate complex real-world systems with the most interactive and visual yet economical simulation software.

MINUTEMAN Software
 P.O. Box 1717, Sioy, Massachusetts, U.S.A.
 (617) 897-5662 ext. 540 (800) 223-1430 ext. 540

Inquiry 742.

ENGINEERING SOFTWARE

You will save hours of development time with our library of integrated programs.

- Graph Plotting
- Simultaneous Equations
- Pop Up Calculator
- Top Down Designer
- Equation Processing
- Complex Arithmetic
- Fourier Transforms
- and more...

For a FREE CATALOG write:
Pulse Research
 Dept Eng S, P.O. Box 696, Shelburne, VT 05482
 (802) 955-2928

Inquiry 743.

HI-RES GRAPHS & STATS

Join scientific, educational, research & engineering institutions across the country analyzing data provided by user-friendly packages.

ENGINEERING TOOL KIT **STATS TOOL KIT**
PROCESS CONTROL CHART TOOL KIT
BIOMEDICAL RESEARCH CHART TOOL KIT
IBM/Macintosh \$99-\$129 ea.

SOFTWARE TOOLS
 P.O. BOX 8751, BOISE, IDAHO 83707
 (208) 343-1437

Inquiry 744.

SOFTWARE/ENGINEERING

PC HYPER-CALCULATOR

Pop-up MS-DOS emulation of HP-11C scientific and HP-12C financial calculators. Two-way transfer, program & data files, alpha prompts, hex/oct/bin arithmetic, 100 registers, 1000 program steps. Free 8087 version, utility programs. \$49.95 + \$3 s&h.

SUNDERLAND SOFTWARE ASSOCIATES
 P.O. BOX 7000-64
 REDONDO BEACH, CA 90277
 CALL TOLL FREE 800-628-2828 ext. 502

Inquiry 745.

ELECTRONIC CIRCUIT ANALYSIS

ECA-2 is a PC based high performance analog circuit simulator w/AC, DC, Transient, Fourier, Worst Case and Monte-Carlo analysis. ECA-2 will handle circuits of approx. 500 nodes and 2500 components. In addition to value and tolerance, the component parameters include Bandwidth, Temperature Coefficient, Delay, Phase Angle and continuous or piecewise non-linearities. Includes component sweeping for optimization. Demo disk available. ECA-2 \$675. One year update service \$120.

TATUM LABS
 1478 Mark Twain Cl., Ann Arbor, MI 48103
 (313) 663-8810

Inquiry 746.

SOFTWARE/GENERAL

3 VANISHING POINTS

- 3-D Perspective Processor: Moving realistic view with complicated rotation capability. \$99** + \$4** S&H.
- Secured Communication System: Conceal information from any level of unauthorized access; Indecipherability is assured by advanced Number Theory. \$349** + \$4** S&H.
- Both require IBM PC or compatible (256K up).

bp-Coding Systems
 2445 University Heights Ave., Boulder, CO 80302
 telephone (303) 442-1943 • facsimile (303) 442-1967

Inquiry 747.

WOULD YOU LIKE TO KNOW?

Your I.Q.? Memory Level? Response Time? Coordination? Visual Perception?

Expand your mind with MENTOR™—software that lets you explore your hidden talents. 58 psychometric exercises, incl. 25 I.Q. tests.

IBM PC/Compatibles • 256K • \$49.95 • VISA/MC

Heuristic Research, Inc.
 3112-A West Cuthbert Ave., Midland, TX 79701
 800-443-7380 (In TX, collect 915-694-5938)

Inquiry 748.

SAVE 90% ON SOFTWARE!

Shareware programs compare favorably to commercial programs costing \$200 and up! EZ Forms, PC Key Draw, PC Outline, PC Accounting, over 170 others to choose from all for \$6.95 or less per disk! Money-back guarantee. IBM PC, Jr, or compatibles. Send today for FREE catalog.

SHAREWARE EXPRESS
 31877 Del Obispo, Suite 102M, San Juan Capistrano, CA 92675

Inquiry 749.

SOFTWARE/GEOLOGICAL

FREE CATALOG!

Geological and scientific software for all applications: log plotting, gridding/contouring, hydrology, digitizing, 3-D solid modelling, synthetic seismogram, fracture analysis, image processing, scout ticket manager, over 50 programs in catalog. Macintosh too!

RockWare, Inc.
 7195 W. 30th Ave., Denver, CO 80215 USA
 (303) 238-9113

Inquiry 750.

SOFTWARE/GRAPHICS

PC TECHNICAL GRAPHICS

TEKMAR is a graphics library for the EGA or Tecmar Graphics Master. Similar to PLOT-10, includes WIN-DOW, VIEWPORT, AXIS. Support for HP, HI plotters. Curve fitting, complete plotting program. Log, semi-log, multi-axis, 3-D, contours. Jerry Pournelle (Aug 86 Byte): "As good as any I have ever seen..." Demo disks, literature available.

Advanced Systems Consultants
21115 Devonshire St. #329, Chatsworth, CA 91311
(818) 407-1059

Inquiry 751.

POPULAR HGRAPH™

SCIENTIFIC 2D & 3D graphic routines for IBM PC and VAX. Powerful, easy to use. Multiple fonts, device and machine independence. Uses max resolution. Links with FORTRAN, Pascal, Turbo Pascal, Logitech Modula 2.

\$79.00 Custom software development.
Graphics editor available soon.

HeartLand Software, Inc.

234 S. Franklin, Ames, IA 50010
(515) 292-8216

Inquiry 752.

GRAPHICS PRINTER SUPPORT

AT LAST! Use the PrtSc key to make quality scaled B&W or color reproductions of your display on any dot matrix, inkjet, or laser printer. GRAFPLUS supports all versions of PC or MS-DOS with IBM (incl. EGA), Tecmar, and Hercules graphics boards \$49.95.

Jewell Technologies, Inc.

4740 44th Ave. SW, Seattle, WA 98116

800-628-2828 x 527 (206) 937-1081

Inquiry 753.

FORTRAN PROGRAMMER?

Now you can call 2-D and 3-D graphics routines within your FORTRAN program.

GRAF-MATIC: 75 callable routines for screen output. \$135.
PLOT-MATIC: Pen plotter driver. \$135.
For the IBM PC, XT, AT and compatibles. We support a variety of compilers, graphics boards and plotters.

MICROCOMPATIBLES

301 Prelude Drive, Dept. B

Silver Spring, MD 20901

(301) 593-0683

Inquiry 754.

PC-KEY-DRAW TRY IT \$15

Comprehensive, high-power graphics editor, CAD, paint, slide show program. Over 160 standard functions plus macros, 64 pages/layers, zoom printer. 600+ patterns, novice/expert modes. \$15 includes manual, software, quick ref. card. Register \$100 for support, updates complete printed manual, from library disks. Shareware. Version 3.27.

OEDWARE

P.O. Box 595
Columbia, MD 21045-0595
(301) 997-9333

Inquiry 755.

GRAPHICS/PICTURE DISKS

* Fabulous * new graphics for PRINT SHOP, PRINT MASTER, NEWSROOM, NEWSMASTER, MACPAINT, PC PAINT, WINDOWS, and PERSONAL PUBLISHER. Available in IBM, Apple, C64 and Kaypro CPM formats. Catalog and demo disk \$9.95 + \$2.50 S/H.

Specify one pgm and one disk format.

Steele Publishing

Dept. B1, P.O. Box 5493, Concord, CA 94524
(415) 685-7265

Inquiry 756.

SOFTWARE/GRAPHICS

CGA → Hercules™ Graphics

Mode-MGA™ allows you to use business graphics, games, BASICA graphics and other CGA specific software with your Hercules™ Monochrome Graphics adaptor and monochrome monitor. Works with all CGA programs. \$79.95 (+ \$5 s&h) for the 3k-TSR version. 30-day money back guarantee. Call or write.

T.B.S.P. Inc.

2265 Westwood Blvd., Suite 793, Los Angeles, CA 90064
(213) 312-0154

Inquiry 757.

SOFTWARE/INVENTORY

SUPER RETAILER™ Is HERE!

Find out why over 500 purchases a second are made on the finest point of sale program. Ultra-flexibility-cash, returns, credit, debts. Control your bus. Keep track of your money. Inventory module. \$99. Become a Super Dealer. Modules for acting integrate automatically. 60 Day Money Back Guarantee. VISA/MC. IBM & compats.

PMC

100 East 2nd Street, Mineola, NY 11501
800-DIAL-PMC in NY 516-294-1400

Inquiry 758.

SOFTWARE/LANGUAGES

Minnesota SNOBOL4.2 Language

Powerful string & data handling facilities. Improved speed, I/O & functions. Interpreter compatible with mainframe SNOBOL4. 64K strings, 32 bit integers, 8087 for float & large memory model. Sample pgms include ELIZA. For > 256K IBM PC & DOS > 2.0. Definitive "green" book by Griswold et al recommended. Programmer's Guide + 5 1/4" SSDS diskette. \$59.95
"Green" book ISBN 0-13-815373-6. \$28.95
Postpaid in USA. In NY add tax. VISA/MC (914) 271-5855

BERSTIS INTERNATIONAL

P.O. Box 441, Millwood, NY 10546

Inquiry 759.

THE PL/M CONNECTION

- Your link to the IBM PC from PL/M 86
- Write programs—Create utilities
- Build application systems
- Complete system interface libraries
- Dos 1, Dos 2, Dos 3, Bios, Graphics
- Large and compact memory modules
- 200 page Technical Reference Manual
- Complete source in PL/M 86 and Assembler
- Demonstration utilities with source

CompuFirm Corporation

7841 Balboa Ave., Ste 210, San Diego, CA 92117
(619) 571-0228

Inquiry 760.

MACINTOSH DEVELOPERS

Speed up application development and PC to MAC porting with compiled libraries. • PROGRAMMER'S EXTENDER VOL. 1 — menus, windows, dialogs, text edit — VOL. 2 — Printing, graphics, lists. • COMMUNICATIONS EXTENDER — serial port support, emulation, file transfer.

Inventory Software Corp.

P.O. Box 3168, Ann Arbor, MI 48106

(313) 996-8108

Inquiry 761.

SCRUTINY

- An advanced symbolic debugger for all MS-DOS computers
- Compatible with Turbo Pascal, Microsoft Assembler, others
- Packed with features. Including support for graphics and 80386 debug registers

M STREET SOFTWARE

5400 E. Mockingbird Lane, Suite 114, Dallas, TX 75206

214-827-4908

Information also available via our 24 hr. 300/1200 modern: 214-669-1882

Inquiry 762.

SOFTWARE/LANGUAGES

POWER with MasterFORTH

MasterFORTH is a complete programming environment for the IBM PC family, the Apple II family, the Macintosh & others. It includes a macro-assembler, full file interface, string package, & resident debugger. Programs can also be optimized with the optional target compiler. \$100-125.

MicroMotion (213) 821-4340

8726 S. Sepulveda Blvd. #A171, Los Angeles, CA 90045

Inquiry 763.

Turbo.ASM

The only package designed to I/F Turbo Pascal and MASM.

Make MASM calls without affecting code space. Pass data back and forth. Learn internals of Turbo Pascal. Use Turbo Pascal to learn MASM! Includes source & more!

PM Tools (415) 366-2062

748 Holly Hill, Redwood City, Ca. 94061 \$45.00

Inquiry 764.

SOFTWARE/MUSIC

SongWright III

Music Processor for IBM Compatibles. Prints quality lead sheets, songs, scores with text and symbols, multiple staves; transposes to any key; plays tunes. Screen graphics editor; IBM/Epson/Star printers. Send \$49.95, \$2 s&h or write for free sample output.

SongWright Software

Route 1, Box 83, Lovettsville, VA 22080

(703) 822-9068

SOFTWARE/REAL ESTATE

MANAGEMENT & ANALYSIS

REAL PROPERTY MANAGEMENT II. . . . \$395/\$595 for apt., shopping centers. . . . Records and budgets income/expense by month/account/unit. Writes checks, invoices, 1099 forms, allocates costs, P&L and cash flow by property and owner.
REAL ANALYZER. . . . \$195 for detailed analysis of residential & commercial properties. Easy "WHAT IF?" 30-day money-back guarantee.

REAL-COMP, INC.

P.O. BOX 1263, CUPERTINO, CA 95015

408-996-1160

Inquiry 765.

SOFTWARE/SCIENTIFIC

DATA ACQUISITION AND ANALYSIS ON PC'S

• MEASURE for Data Acquisition directly to Lotus 123 • FOURIER PERSPECTIVE II advanced Digital Signal Analysis • PRIME FAC TOR FFT subroutines library. Call from Turbo Pascal, C, Fortran, Basic. Up to 65,520 data points. 2D Interface available. Rectangular FFTs now possible in a multitude of dimensions • TURBO PASCAL science/engineering tools from Quinn-Curtis • 2 & 3D scientific graphic packages with plotter support from Golden Software • MATHCAD by Mainsort creates & edits equations • 8087 Math Coprocessors. all varieties • Data Acquisition & Control Boards from Metrabyte.

LOW prices — FREE Customer Service — Satisfaction GUARANTEED

ALLIGATOR TECHNOLOGIES

P.O. Box 11388, Costa Mesa, CA 92627

(714) 722-1842

Inquiry 766.

ORDINARY/PARTIAL DIFFERENTIAL EQU SOLVER

FOR THE IBM PC & COMPATIBLES

MICROCOMPATIBLES INC.

301 Prelude Dr., Silver Spring, MD 20901

(301) 593-0683

Inquiry 767.

THE BUYER'S MART

SOFTWARE/SCIENTIFIC

SCI-GRAF and SCI-CALC

SCI-GRAF produces huge hi-res graphs thru easy menus or linkable C libraries. Supports log scales, error bars, screen and printer output.

SCI-CALC is a pop-up calculator with complete expression editing, scientific, statistical, and logic functions.

Prices start at \$79.95.

Microcomputer Systems Consultants

Box 747, Santa Barbara, CA 93102

(805) 963-3412

Inquiry 768.

FitAll

NONLINEAR REGRESSION ANALYSIS

★ TurboPascal v3 source for PC/XT/AT with CGA

★ Menu of 20 user-definable functions (models)

★ Multiple independent variables ★ Weighting

★ 2D plots ★ Manual on disk

★ \$45US (\$60Can) + \$5US outside USA & Canada

MTR Software

P.O. Box 13, Irlington A, TORONTO, Ontario M9A 4X1 Canada

Inquiry 769.

Linear Programming

MATRIX CALCULATOR reads and writes LOTUS WKS files, performs linear programming, linear regression, solve system of equations, and other matrix operations. Requires 8087. \$60 includes free source. \$120 w/Turbo Pascal source code plus more.

SoftTech Inc.

14640 LaBelle, Oak Park, MI 48237

1-313-544-8544

Inquiry 770.

SOFTWARE/SORT

OPT-TECH SORT/MERGE

Extremely fast Sort/Merge/Select utility. Run as an MS-DOS command or CALL as a subroutine. Supports most languages and filetypes including Btrieve and dBASE. Unlimited filesizes, multiple keys and much more! MS-DOS \$149. XENIX \$249.

(702) 588-3737

Opt-Tech Data Processing

P.O. Box 678 - Zephyr Cove, NV 89448

Inquiry 771.

SOFTWARE/TOOLS

What is Turbo GhostWriter?

An Application Generator for Turbo Pascal™ Complete Database in Minutes!

Draw & paint screens with our tools. Tell Turbo GhostWriter how to retrieve your data. Screen Editor/Painter, FABS PLUS B-Tree File Manager, Multiple fields/key, Multiple keys/index, Application Generator produces Context Sensitive Help & Documentation. All for only \$200! 60-day money back guarantee. MC/VISA/PO/COD-Company Check. In NC (919) 782-7703

Info/orders call 800-227-7681

ASCII-Automated Software Concepts International, Inc.
3239 Mill Run, Raleigh, NC 27612-4135

Inquiry 772.

LAN TOOLBOX FOR TURBO PROGRAMMERS!

Have a special application database that's restricted to one computer at a time? Do you need to share that database using record locking and unlocking commands? Are you frustrated with the limitations of Turbo Pascal file handling routines when DOS 3.X have those capabilities? If you answered yes to any of these questions, this package is definitely worth the money. After all, this is the year of the LAN. \$99.95. VISA/MC accepted.

Night Owl Computer Services

Software & Consulting

P.O. Box 138037, Toledo, OH 43613 (419) 474-9248

Inquiry 773.

SOFTWARE/TOOLS

SCREEN MANAGER

MENU, WINDOW, and DATA ENTRY Support for the Professional Programmer! Interfaces to most languages. BASIC, C, FORTRAN, COBOL, PASCAL, ASSEMBLER. 100 Page Manual. Thirty day money back guarantee. No Royalties.

from \$79. Visa/MC

The West Chester Group

P.O. Box 1304, West Chester, PA 19380

(215) 644-4206

CALL FOR FREE DEMO

Inquiry 774.

STATIONERY

Custom PC Stationery

Continuous printed letterheads w/micro perf edges. Matching window or regular envelopes. Numerous colors. Inks & papers at lowest prices. Fast delivery & top quality. We'll print your present design or set type for your new design.

Call toll free 800-624-2961 (TN: 901-756-7010) for free samples & price info. or write:

PerFORMS Press

8456 Lofton Cove, Cordova, TN 38018

Inquiry 775.

STATISTICS

PRO ☆ CAST

FORECAST SALES, INVENTORIES, etc.

Complete time series analysis — trend, seasonality, exponential smoothing, Box Jenkins, and more. Great graphics! Exchange data with other programs. \$150. 30-day m/b guarantee. Demo \$10. IBM-PC or compatible.

FLEMING SOFTWARE

P.O. Box 528 • Oakton, VA 22124 • (703) 591-6451

Inquiry 776.

STATISTICS CATALOG!

If you need statistics for IBM PC or Apple II, call us and let our technical advisors help you find the statistics programs you need.

Write or call now to get a FREE catalog of statistics and quality control software.

HUMAN SYSTEMS DYNAMICS

9010 Reseda Blvd., Ste. 222

Northridge, CA 91324

(800) 451-3030 (818) 993-8536 (CA)

Inquiry 777.

NUMBER CRUNCHER STAT SYS

Menu-driven. Multiple & stepwise regression, ANOVA, time series, discriminant cluster and factor analysis, principal components, scatter plots, histograms, t-tests, contingency tables, non-parametrics. Import export data. Spreadsheet, sort, join, merge. \$99. MS-DOS. Quantity discount.

NCSS-B

865 East 400 North, Kaysville, UT 84037

801-546-0445

Inquiry 778.

STATISTIX™ II

Comprehensive, powerful and incredibly easy-to-use. Full screen editor, transformations, linear models (ANOVA, regression, logit, PCA, etc.), ARIMA, most standard stat procedures. Clear, well organized documentation. Satisfaction guaranteed. \$169 PC DOS. \$99 Apple II.

NH ANALYTICAL SOFTWARE

P.O. Box 13204, Roseville, MN 55113

(612) 631-2852

Inquiry 779.

STATISTICS

SL-MICRO

Tabulate survey results or analyze experimental data using SL-MICRO. It has Frequencies with statistics, Crosstabs, Anova, T-Test, Multiple Regression & Correlation. Data Editor & Data Transformations.

Only \$250 for PC-DOS, MS-DOS or CP/M

QSC, Box 778, East Lansing, MI 48826

(517) 641-4428

Inquiry 780.

RATS! Version 2.1

Best selling econometrics program. Over 4000 copies sold. OLS, 2SLS, logit, probit and much more! Forecasting with ARIMA, VAR. Exponential smoothing. Model simulations. Support for daily/weekly data. High quality graphics to screen, plotter, printer. \$200-\$300. VISA/MC Demo available.

VAR Econometrics, Inc.

P.O. Box 1818, Evanston, IL 60204-1818

(312) 864-8772; (800) 822-8038

Inquiry 781.

StatPac Gold™

StatPac Gold is the high-powered statistics and forecasting package that delivers! It's fast, flexible, easy to use and dependable. Time-tested and loaded with features. It's all here! Unlike any other. Get the facts! Call now for your FREE brochure.

1-800-328-4907

Walonick Associates, Inc.

6500 Nicollet Ave. S., Minneapolis, MN 55423

(612) 866-9022

Inquiry 782.

Spreadsheet Statistics

NEW! 23 comprehensive statistics and forecasting modules for analyzing LOTUS worksheets. Low cost \$24.95 each. Easy to use. Includes tutorial. Basic and advanced statistics with graphics and many user-definable options. Compare. Free brochure.

Walonick Associates, Inc.

6500 Nicollet Ave. S., Minneapolis, MN 55423

(612) 866-9022

Inquiry 783.

TERMINAL EMULATORS

Datapoint Terminal Emulators

Increase the usefulness of your personal computer and Datapoint investment. Connect your PC or PC clone with any Datapoint computer. Full terminal emulation, file transfer, and MS/DOS hot key, while using DOS or RMS. Requires only IBM compatible and async comm adaptor. Full source code available. 8242, 8220 or 3600 terminal emulators \$179.95 ea.

MC/Visa/COD (206) 391-3725

LAN Comp Systems

14524 Issaquah-Hobart Road, Issaquah, Washington 98027

Inquiry 784.

UTILITIES

SOURCE CODE LIBRARIAN & VERSION CONTROL SYSTEM

TLIB™ keeps ALL versions of your program in ONE compact library file, even with hundreds of revisions.

- 5 times faster than SCCS • LAN compatible
- Free public domain MAKE (with source) by L. Dyer
- MS/PC-DOS 2.x & 3.x. \$99.95 + \$3 S&H. VISA/MC

BURTON SYSTEMS SOFTWARE

POB 4156, Cary, NC 27511

(919) 469-3068

Inquiry 785.

THE BUYER'S MART

UTILITIES

ASSEMBLY LANGUAGE PRE-PROCESSOR

Add high level features to any assembler for any micro. Supports "begin," "while," "repeat," "until," "if," "switch," and other constructs as efficiently as hand-coded assembler. Checks program integrity and eliminates bugs. Create manuals with tables of content from comments in your programs with our DOCUMENT EXTRACTOR. Call for more info: Pre-processor \$29.95, Document Extractor \$19.95, BOTH for \$39.95. Includes manual.

HADDICK & HADDICK

P.O. Box 1586, Mexia, TX 76667 817-582-3444

Inquiry 786.

UTILITIES

PAL FOR SIDEKICK!

Personal Appointment Locator automatically shows coming appointments, searches your file, maintains to-do list, automatically repeats appointments, examines multiple files. Resident alarm too! Only \$49.95. Cheap at twice the price!

PAL SOFTWARE

Ste. 12B 110 Green St., New York, NY 10012
(Voice Line) 914-762-5322
(BBS) 914-762-8055

Inquiry 790.

WORD PROCESSING

NEW WORD

A WordStar clone, but better.
Act now—limited quantities available
For CP/M-80 — \$69.00
Includes WORD Plus by Oasis. Specify disk format
Add \$4.30 S/H, CA residents add 6% tax.
Check/MO, Visa, MC/COD

ANAPRO

213 Terf Sue Lane, Dept. B, Buellton, CA 93427
805-688-0826

HEBREW / GREEK / ARABIC

Russian and European Languages. Full featured, multi-language word processor supports on-screen foreign characters with no hardware modifications. \$350 (dot matrix) or \$500 (laser) + \$5 s/h. Or send \$15 + \$4 s/h for demo. Req. 512K/graphics

Gamma Productions, Inc.

710 Wilshire Blvd., Suite 609, Santa Monica CA 90401
(213) 394-8622

Inquiry 794.

PEP Your Data to MS-DOS!

PEP ("Printer Emulation Package") is a unique software product which makes your MS-DOS system appear to be an intelligent serial printer. Converting your data from another operating system is as easy as printing it! Diskette plus 90 page typeset manual, \$64.95 U.S. (Not copy protected.) Specify 5 1/4 or 3 1/2 inch diskette size; add \$5 for both formats.

Intelpro

13 Saratoga Dr., Kirkland, Quebec, Canada H9H 3J9
(514) 694-6862

Inquiry 787.

Recover deleted files fast!

Disk Explorer now includes automatic file recovery. You type in the deleted file's name. Disk Explorer finds and restores it. Disk Explorer also shows what's really on disk; view, change or create formats, change a file's status, change data in any sector. MS-DOS \$75 U.S. Check/Credit card welcome.

QUAD SOFTWARE LIMITED

45 Charles St. E. 3rd Fl.
Toronto, Ontario, Canada M4Y 1S2
(416) 961-8243

Inquiry 791.

DuangJan 1.3

Bilingual word processor for English and one of these: Armenian, Bengali, Euro/Latin, Greek, Hindi, Khmer, Lao, Russian, Tamil, Telugu, Thai, Viet, . . . or create your own language with font editor. \$69 + \$4 s/h (+\$10 for) LaserJet + \$49. Demo \$5. IBM compatible.

MegaChomp Company

3524 Cottman Avenue, Philadelphia, PA 19149-1606
(215) 331-2748/8138

Inquiry 795.

EditingTools 2.1

Now you can have a slick full-screen multifile text editor for only \$35. Enjoy the ease of editing many files at once and the freedom of moving text among files. File sizes are limited only by memory. With an easily reconfigurable keyboard and a convenient multidirectory DOS shell. Add \$4 for s/h.

Jou Laboratories

P.O. Box 460969, Garland, TX 75046
214-495-8862

Inquiry 788.

PC-Write™ Shareware Ver. 2.71

Fast, full featured word processor/text editor for IBM PC. With spell check, screen clip, mailmerge, split screen, ASCII files, macros. Easy to use. Supports 400 printers - LaserJet+ and PostScript. Software, User Guide, and Tutorial on 2 disks for \$16. Try it, then register with us for only \$89 and get User Manual, 1 year tele-support, newsletter and 2 upgrades. 90-day guarantee. VISA/MC.

Quicksoft (206) 282-0452 CALL TODAY!
219 First N., #224-BYTC, Seattle, WA 98109

Inquiry 792.

HANDS OFF™ PC SECURITY

- Locks Hard Disk. - Restricts Floppy Use.
- Protects Subdirectories.
- Normal Use of DOS Commands and Application Software.
- IBM PC, XT, AT and True Compatibles.
- DOS V2.0 and Higher. Hard Disk System.
- Keep Other People's HANDS OFF Your System

\$89.95

SYSTEM CONSULTING, INC.

314 Canterbury Dr., Pittsburgh, PA 15238
(412) 963-1624

Inquiry 793.

ADVERTISE YOUR COMPUTER PRODUCTS HERE

for as little as \$375 in
THE BUYER'S MART

For more information call
Mark Stone at BYTE

603-924-3754

ATs DON'T NEED 360KB DRIVES

The 1.2mb drive has long been known to READ but NOT reliably WRITE on 360KB floppies. With "CPYAT2PC"™ 1.2mb drives CAN reliably WRITE 360KB floppies saving a slot for a second hard disk or backup tape. "CPYAT2PC"™ (Not Copy Protected) offers the preferable SOFTWARE SOLUTION. ONLY \$79 + \$4 S/H VISA/MC/COD UPS B/R

MICROBRIDGE COMPUTERS

655 Skyway, San Carlos, CA 94070
Order toll free 1-800-621-0851 x777
415-593-8777 (CA) 212-334-1858 (NY)
TELEX EZLNK 62873089 Dealer Inquiries Invited

Inquiry 789.

TRI STATE COMPUTER

160 BROADWAY, NEW YORK, NY 10038

(Bet. Maiden Lane and Liberty St.)

(212) 349-3134 • Open weekdays 9-6, Sunday 10-4

CALL TOLL FREE ORDERS ONLY 1-800-221-1926

PRINTERS

Leading Edge Model D

- 512K Dual Floppy
- Keyboard \$899⁹⁵
- Monitor \$1149⁹⁵
- w/20 MB

NEC Power Mate I

- AT Compatible
- 640K 80286 8 MHz
- 1.2 FD. DOS
- HD controller card \$1299⁹⁵

SUPER SPECIALS

Seagate ST 225 w/cont. 299.95
Plus 20 MB 579.95

MODEMS

EVEREX 1200B 99.95
EVEREX 2400B 179.95
EXTERNAL 1200 129.95
EXTERNAL 2400 249.95

HP Laser Jet Series II

w/toner 1649.95

IBM Pro Printer XL \$509.95
IBM Pro Printer II \$354.95
Epson LX 800 CALL
Epson FX 86E \$299.95
Epson FX 286E \$419.95
Epson LQ 800 \$414.95
Epson LQ 1000 \$349.95
Epson EX 800 \$384.95
Epson EX 1000* \$829.95
Epson LQ 2500 \$349.95
Panasonic KXP 1080i \$154.95
Panasonic KXP 1091i \$264.95
Panasonic KXP 1592 \$344.95
Panasonic KXP 1595 \$374.95
Panasonic KXP 3131 \$223.95
Panasonic KXP 3151 \$349.95
OKI ML 293e \$474.95
OKI ML 292e \$349.95
OKI ML 192 \$259.95
OKI ML 192 Plus \$289.95
OKI ML 193 Plus \$439.95
NEC P6 \$399.95
NEC P7 \$569.95
NEC P9 \$999.95
Toshiba 341-SL \$649.95
Toshiba 351-2 \$799.95
Toshiba 321 SL \$459.95

AT&T 6300

6300 1 - 360K FD
• 640K RAM, • Graphics Card
• Clock/Calendar
• Keyboard \$849⁹⁵
w/20 MB HD \$1149⁹⁵

Epson Equity I Plus

- 640K Dual Floppy
- Parallel Serial Ports
- DOS & Basic
- Keyboard, • Video Board
- Mono Monitor \$949⁹⁵
- w/20 MB \$1199⁹⁵

Epson Equity II

- 640K 1-360K FD
- Parallel Serial Ports
- DOS & Basic
- Keyboard, • Video Board
- Mono Monitor \$949⁹⁵
- w/20 MB \$1249⁹⁵

* after mfg. rebate

MC & VISA ACCEPTED
NO ADDITIONAL CHARGE

Laptop Computers

Toshiba T3100 2649.95
Sharp PC 7100 1849.95
Zenith Z-181 1599.95
Zenith Z-183 2299.95
NEC Laptop 1349.95
Brooklyn Bndge 89.95

Apple Computers

Apple II GS 709.95
Apple RGB Monitor 399.95
Macintosh Plus 1599.95
Mac SE Dual Floppy 2149.95
Mac SE Hard Drive 2799.95
SE Keyboard 109.95
Imagewriter II 439.95

MX 286 TURBO

- AT Compatible
- 80286 6 & 10 MHz
- 1.2 FB. • 0 Wait State
- Phoenix Bios
- 1 year warranty \$949⁹⁵

MX TURBO XE

- 640K 1-360K FD
- Serial & Parallel Port
- Game Port, • Video Board
- Mono Monitor \$569⁹⁵



IBM XTs & Sys/2 Mod. 50's

- ENH XT — (Model 286)
- 640K 80286 6 MHz.
- 1.2 Drive IBM 20 MB HD
- IBM Keyboard \$1649⁹⁵

System 2 Model 50

- 80286 10MHz processor
- 1MB RAM standard
- Built-in parallel & serial ports
- 20MB hard disk
- 1.4MB 3 1/2" drive
- Enhanced keyboard \$2649⁹⁵

Enhanced AT 339

- 512K 1.2 FD
- IBM 30MB HD
- IBM Keyboard \$3299⁹⁵

COMPAQ Portable III

Model 20
• 640K 1.2 FD 12 MHz \$3749⁹⁵
• 20 MB 40
Mod. 40 w/40 MB HD \$4299⁹⁵

All items subject to availability and price changes. Mail and phone orders C.O.D., MC and VISA, S&H extra. Not responsible for typographical errors. All systems fully tested and installed by Tri State Computer. Printer price w/purchase of cable only.

Special to BYTE readers — Full Size Printer Stand \$12.95

Inquiry 297



Compu\$ave

Call Toll Free: 1-800-624-8949

BOARDS

ATI EGA Wonder	244	Artist 1	1249
Genoa EGA Hi-Res	332	Chauffeur HT	152
Hercules Graphics +	175	NEC GB-1	292
Graphics Solution	135	Paradise 480	265
Ramquest 50/60	CALL	Sigma 400	275
STB Multi-Res II	229	Vega Deluxe	282
Alloy & Advanced Digital Slave Boards	SAVE		
Quadram Ultra VGA & Future Card	CALL		
Panasonic FAX Partner	649		
Taxan 560 EGA Auto-Switch (Paradise)	179		
Awesome I/O Card (More & Faster)	CALL		
AST/Boca BNW/Everex/#9/Orchid/Persyst	CALL		
PGX/Talltree/Teclmar/Iseng/Verticom/VMI	CALL		

MONITORS

Amdek 1280 W/Card	679	Amdek 410	148
Genius 402 W/Card	1295	IC 19' EGA	1395
Mitsubishi Multi	479	PGS LM300	489
NEC Multisynch	525	PGS MAX-12	138
NEC Multisynch +	899	Taxan 770	535
NEC Multisynch XL	2065	Taxan 980	CALL
Sigma Laser 19"	1729	Conrac	CALL
Wyse 700 W/Card	689	Thomson 450A	152
Microvitek Autosynch; 19"/1360 x 880	1695		

IMAGE SCANNERS

AST Turbo-Scan With Sheet Feeder	1699
Dalacopy Model 730	1275
PGS LS-300 With OCR Soft. & Adapter	985
Panasonic FX-RS 505	1029

COMPUTERS

IBM-PS 2 30	1495	AST Model 80	1465
IBM-PS 2 50	3095	AST Model 90	1849
IBM-PS/2 80	6095	AST Model 120	2199
NEC Multispeed	1395	AST Model 140	2495
Toshiba T-1000	845	AST Model 170	2899
AT&T 6300; 640K/1 Drive/Monitor	1165		
Cordata CS40; 8 MHz/2 Drives/Monitor	839		
Televideo 386; 16 MHz/2M/1.2M Drive	2595		
Multitech 1100; 80386/44M Drive	3145		
Multitech 1100-B8; 80386/80M Drive	3825		
Sharp Portables & Laptops	CALL		
Sperry IT; 1M/44M Drive/Keyboard	2799		
Toshiba T1100 + /T1200/T3100	SAVE		
Wyse 286; 10 MHz/640K/1.2M Drive	1339		
Wyse 2108; 8 MHz/512K/1.2M Drive	1149		
Wyse 2212; 12.5 MHz/1M/1.2M Drive	1619		
Wyse 386; 16 MHz/1M/1.2M Drive	2695		
Wyse + Turbo; 640K/2 Drives	975		
Multitech 1100-B13; 80386/130M Drive	5195		
Altos/Compaq/Bondwell/ITT/Zenith	CALL		

TERMINALS

Adds 2020	415	Oume 101 +	319
Ampex 220	399	Wyse 30	282
IBM 3151	CALL	Wyse 50	355
Kimtron KT70	339	Wyse 60	399
Televideo 905	285	Wyse 85G	422
Televideo 955	389	Wyse 99GT	CALL
Altos/Hazeltine/Liberty/Link/Visual	CALL		

PLOTTERS

Houston PC595	499	Houston 41/42	2325
Houston PC695	585	Houston 51/52	3325
Houston DMP29	1625	Houston 56A	4175
Houston DMP40	859	Roland 880	945
Houston 51/52MP	3745	Roland 885	1195
Calcomp 1042GT	8195	Roland 980	1199
Enter SP600	729	Roland 2000	4095
Ioline 4000	4195	Roland 3300	5345
Numonics/Taxan/Other Makes & Models	CALL		

DIGITIZERS

Calcomp 44 x 60	4995	GTCC 24 x 36	2099
Hitachi 11 x 11	459	Kurta 12x12	355
Hitachi 15 x 15	1045	Kurta 8.5 x 11	299
Houston TG1011	495	Kurta 12 x 17	559
Kurta IS Series	CALL	Numonics 2020	1245
MS BUS Mouse	109	Summa 12 x 12	365
Mouse Sys. Serial	99	Summa 12 x 18	642
Scriptel/Mouse Systems/Other Mice	CALL		

MODEMS

Novation Parrot	105	Hayes 1200	279
Prometheus 2400G	219	Hayes 1200B	262
Ven-Tel 2400 +	368	Hayes 2400B	395
Ven-Tel 2400 i	292	Zoom 2400ST	329
Multitech 224E; (#1 Rated)	388		
Practical Half-Card 1200; W Software	99		
Racal-Vadic 2400-VP; (#1 Rated)	398		
US Robotics 2400; Internal	185		
US Robotics HST 9600	669		
Anchor/Avatex/Case/Migent/Prentice/UDS	CALL		

PRINTERS

Alps ALQ-224	475	Citizen 1200	162
Citizen Premier 35	455	Citizen MSP20	295
Panasonic 1524	595	C. Itoh C715	975
Toshiba 351C II	1019	Diconix 150	295
Citizen Tribute	609	Fujitsu 3400	669
Panasonic 1080i	154	NEC P660	422
Panasonic 1091i	168	NEC CP660	519
Panasonic 1092i	294	NEC P760	592
Panasonic 1592	385	NEC CP760	682
Panasonic 1595	418	NEC P9XL	1119
Star NP10	142	Okidata 192 +	312
Citizen MSP50/55	CALL	NEC P5XL	985
Data Prod/Data So/Epson/OTC/Seikoshu/TI	CALL		
Buffers/Sheet Feeds/Switches/Tractors	SAVE		

LOW PRICES FOR LASER PRINTERS

Citizen Overture	1749	AST Turbo	2895
Ok Laserline 6	1379	Canon 8-II	1689
Panasonic 4450	1375	D. Prod. 1230	2695
Quadram Quadlaser	2665	NEC LC860 +	2025
Toshiba Page 12	2445	Qume L10 +	2465

DISK DRIVES

Miniscribe 20M Card	389	Apple Drives	99
Mountain 30M Card	565	Maxtor 190M	2565
Plus Hardcard 40	865	Miniscribe 80M	819
Seagate 20M Kit	279	Miniscribe 40M	425
Seagate 30M Kit	345	Seagate 40M	485
Toshiba 3.5 Kit	112	Seagate 4096	865
Alloy/CDC/Irwin/Maynard/Newbury/Pnam	CALL		
Rodime/Tallgrass/Teac/Teclmar/W. Digital	CALL		

**HOURS: MON-FRI 7AM-6PM/SAT 9AM-2PM
IN ARIZONA CALL (602) 437-4855**

CompuSave: 4207 S. 37th St., Phoenix, AZ 85040/Prices Reflect Cash Discounts And Are Subject To Change Without Notice. Major Credit Cards And Selected PO's Are Accepted. We Cannot Guarantee Compatibility. CompuSave Is A Division Of Adlanko Corporation.

OUR REPUTATION WAS BUILT ON SUN-286 PLUS

80286 COMPUTER

(Sun-286 Plus)

IBM PC/AT COMPATIBLE



1 YEAR WARRANTY
(PARTS & LABOR)

\$895.

- ✓ 8/6 MHz 80286 CPU (OPTION 10/6 MHz)
- ✓ OPERATING SPEED SELECT BY KEYBOARD
- ✓ ZERO WAIT-STATE STANDARD
- ✓ AT COMPATIBLE PHOENIX BIOS
- ✓ 20% LESS SPACE THAN PC/AT
- ✓ KEYLOCK, POWER & TURBO LED ON FRONT
- ✓ 72 HOURS BURN-IN
- ✓ 7 EXPANSION SLOTS (5-16 BIT, 2-8 BIT)
- ✓ CLOCK CALENDAR W/BATTERY BACK-UP
- ✓ 8/6 MHz CPU W/ 512 K RAM
- ✓ 1.2 MB FLOPPY DISK DRIVE
- ✓ FLOPPY/HARD DISK COMBINATION CONTROLLER
- ✓ 185 WATT POWER SUPPLY
- ✓ AT STYLE KEYBOARD
- ✓ FULLY ASSEMBLED & TESTED

EGA SYSTEM

\$1510.

- STANDARD SYSTEM WITH...
- ✓ EGA CARD (EGA+CGA+MDA) W/256K RAM
 - ✓ EGA MONITOR (14" RGB, 0.31mm DUAL SCAN)
 - ✓ SERIAL, PARALLEL PORT
- W/20 MB (65 MS).....\$1825.
W/30 MB (40 MS).....\$2140.

MONO SYSTEM

\$1040.

- STANDARD SYSTEM WITH...
- ✓ MONOGRAPHIC CARD
 - ✓ W/PARALLEL PORT
 - ✓ TTL 12" GREEN MONITOR
- W/20 MB (65 MS).....\$1355.
W/30 MB (40 MS).....\$1670.

XT TURBO 10 Mhz

(SUN-ST Plus)

TWICE AS FAST AS PC/XT

- 1 MEG RAM (640K/384K EMS)
- 2 FDD
- MONO G. CARD
- TTL 12" MONITOR
- 150W P.S.
- AT STYLE KEYBOARD

\$795.

XT TURBO 8 Mhz

(SUN-ST)

- 640K, 2 FDD
- MONO G. CARD
- TTL 12" MONITOR
- 150W P.S.
- AT STYLE KEYBOARD
- 1 YEAR WARRANTY

ASLOW AS \$639.

CALL FOR OTHER CONFIGURATIONS

SUNTRONICS

1-800-421-5775
(213) 644-1140

12603 CRENSHAW BLVD., HAWTHORNE, CA 90250

©1988 VISA MasterCard Plus Discover. Good Cash or Certified Check (VISA or MC Ref. Standard) School & Corp. Contractor P.O. Enclosed Shipping & H.C. \$4.00 for 3 lbs plus \$4.00 per each additional lb. CA Residents & so CA Sales Tax. \$10.00 minimum order. WARRANTY: System 1 Year Warranty, Labor, Parts Replacement Only. Components 90 Days Warranty. IBM, PCAT, MICROVITEK, NEC, BALL, EPSON, OHP & TCC/NEC/ODK, are all registered trademarks of their respective companies.

QUALITY, COMPATIBILITY, & SERVICE ... PROVEN BY ROCKWELL INT'L CORP.

Mail-Order Electronics

FOR ORDERS ONLY 415-592-8097 ALL OTHER INQUIRIES 415-592-8121

NEC V20 & V30 CHIPS

Replace the 8086 or 8088 in Your IBM-PC and Increase Its Speed by Up to 40%!

Part No.	Price
UPD70108-5 (5MHz) V20 Chip	\$ 9.95
UPD70108-8 (8MHz) V20 Chip	\$11.95
UPD70108-10 (10MHz) V20 Chip	\$34.95
UPD70116-8 (8MHz) V30 Chip	\$14.95
UPD70116-10 (10MHz) V30 Chip	\$34.95

7400

Part No.	1-9	10+	Part No.	1-9	10+
7400.	29	19	7485.	65	55
7402.	29	19	7486.	45	35
7404.	35	25	7489.	2.05	1.95
7405.	39	29	7490.	49	39
7406.	39	29	7493.	45	35
7407.	39	29	74121.	45	35
7408.	35	25	74123.	59	49
7410.	35	25	74125.	55	45
7414.	49	39	74126.	75	65
7416.	45	35	74143.	4.05	3.95
7417.	45	35	74150.	1.35	1.25
7420.	35	25	74154.	1.35	1.25
7430.	35	25	74158.	1.59	1.49
7432.	39	29	74173.	85	75
7438.	39	29	74174.	65	55
7442.	45	35	74174.	65	55
7445.	79	69	74176.	99	89
7446.	89	79	74181.	1.95	1.85
7447.	89	79	74189.	2.05	1.95
7448.	2.05	1.95	74193.	79	69
7472.	75	65	74198.	1.85	1.75
7473.	35	25	74221.	99	89
7474.	45	35	74273.	2.05	1.95
7475.	49	39	74365.	69	59
7476.	45	35	74367.	69	59

74LS

74LS00.	29	19	74LS165.	75	65
74LS02.	29	19	74LS166.	99	89
74LS04.	35	25	74LS173.	59	49
74LS05.	35	25	74LS174.	49	39
74LS06.	1.09	99	74LS175.	49	39
74LS07.	1.09	99	74LS189.	4.59	4.49
74LS08.	29	19	74LS191.	59	49
74LS10.	29	19	74LS193.	79	69
74LS14.	49	39	74LS221.	69	59
74LS27.	35	25	74LS240.	79	69
74LS30.	29	19	74LS243.	79	69
74LS32.	35	25	74LS244.	79	69
74LS42.	49	39	74LS245.	89	79
74LS47.	99	89	74LS259.	99	89
74LS73.	39	29	74LS273.	89	79
74LS74.	35	25	74LS279.	49	39
74LS75.	39	29	74LS322.	4.05	3.95
74LS76.	55	45	74LS365.	49	39
74LS85.	59	49	74LS366.	49	39
74LS86.	35	25	74LS367.	49	39
74LS90.	49	39	74LS368.	49	39
74LS93.	49	39	74LS373.	79	69
74LS123.	59	49	74LS374.	79	69
74LS125.	49	39	74LS393.	89	79
74LS138.	49	39	74LS590.	6.05	5.95
74LS139.	49	39	74LS624.	2.05	1.95
74LS154.	1.09	99	74LS625.	2.29	2.19
74LS157.	45	35	74LS640.	1.09	99
74LS158.	45	35	74LS645.	1.09	99
74LS163.	59	49	74LS670.	1.09	99
74LS164.	59	49	74LS688.	2.05	1.95

74S/PROMS*

74S00.	29	74S188*	1.29
74S04.	35	74S189.	1.69
74S08.	35	74S196.	2.49
74S10.	39	74S240.	1.49
74S32.	35	74S244.	1.49
74S74.	45	74S253.	1.79
74S85.	1.79	74S287*	1.49
74S86.	35	74S288*	1.49
74S124.	2.95	74S373.	1.49
74S174.	79	74S374.	1.49
74S175.	79	74S472*	2.95

74F

74F00.	39	74F139.	.89
74F04.	39	74F157.	.95
74F08.	39	74F193.	3.95
74F10.	39	74F240.	1.39
74F32.	39	74F253.	.99
74F47.	49	74F253.	.99
74F86.	59	74F373.	1.39
74F138.	89	74F374.	1.39

CD-CMOS

CD4001.	.19	CD4076.	.65
CD4008.	.89	CD4081.	.25
CD4011.	.19	CD4082.	.25
CD4013.	.29	CD4093.	.35
CD4016.	.39	CD4094.	.89
CD4017.	.55	CD40103.	2.49
CD4018.	.59	CD40107.	-.69 39
CD4020.	.59	CD40109.	-1.49 79
CD4024.	.49	CD40110.	.69
CD4027.	.35	CD40111.	.75
CD4030.	.29	CD40120.	.35
CD4040.	.65	CD40122.	.79
CD4049.	.29	CD40138.	.79
CD4050.	.29	CD40141.	.69
CD4051.	.59	CD40143.	.79
CD4052.	.59	CD40153.	4.95
CD4053.	.39	CD40155.	1.79
CD4053.	1.95	CD40159.	7.95
CD4056.	.29	CD40166.	2.49
CD4057.	2.39	CD40183.	.89
CD4069.	.25	CD40584.	.39
CD4070.	.25	CD40585.	.89
CD4071.	.25	MC14411P.	8.95
CD4072.	.25	MC14490P.	4.49

MICROPROCESSOR COMPONENTS

MISCELLANEOUS CHIPS		6500/6800/68000 Cont.		8000 SERIES Cont.	
Part No.	Price	Part No.	Price	Part No.	Price
D765AC	4.49	6845.	2.95	822B.	2.49
WD9216.	9.95 6.35	6850.	1.49	8237-5.	4.95
Z80, Z80A, Z80B SERIES					
Z80-CTC.	1.25	6852.	9.95 2.49	8243.	2.25
Z80-DART.	4.95	MC68000LB.	11.95	8250A.	5.49
Z80-Pi0.	1.79	MC68000L10.	14.95	8250B (For IBM).	6.95
Z80A.	1.35	MC68010L10.	49.95	8251A.	1.75
Z80A-CTC.	1.49	MC68020RC12B.	199.95	8253-5.	4.95
Z80A-DART.	4.95	MC68681 RC12A.	199.95	8254.	1.95
Z80A-Si0.0.	4.95	8000 SERIES			
Z80B.	2.95	8031.	2.95	8255A-5.	1.69
Z80B-CTC.	3.49	80C31BH.	14.95 10.95	8257-5.	2.49
Z80B-Pi0.	4.29	8035.	1.49	8259-5.	1.95
6500/6800/68000 SER					
6502.	2.25	8073.	29.95	8272.	4.49
6502C (CMOS).	6.95	8080A.	2.49	8273-5.	2.95
6520.	1.75	3085A.	2.29	8741.	10.95
6522.	2.95	8086.	6.95	8748B (25V).	9.95
6532.	6.49	8086-2.	8.95	8748H (HMOS) (21V).	10.95
6551.	3.29	8087 (5MHz).	125.00	8749.	9.95
65C202 (CMOS).	19.95	8087-2 (8MHz).	158.95	8751.	39.95
6800.	1.75	8088.	6.49	8755.	14.95
6802.	3.49	8088-2.	8.95	DATA ACQUISITION	
6810.	1.25	8116.	4.95	ADC0804LCN.	3.19
6821.	1.29	8155.	1.95	ADC0808CCN.	5.95
6840.	3.95	8155-2.	2.49	ADC0809CCN.	3.95
MICROPROCESSOR SALE!					
Part No. Price					
MC68000L8	16-Bit MPU (8MHz)	\$ 11.95			
MC68000L10	16-Bit MPU (10MHz)	\$ 14.95			
MC68000L12	16-Bit MPU (12MHz)	\$ 17.95			
MC68008L8	32-Bit MPU (8-Bit Data Bus)	\$ 19.95			
MC68010L10	16-Bit MPU (10MHz)	\$ 49.95			
MC68020RC12B	32-Bit MPU (12MHz)	\$ 199.95			
MC68701	8-Bit EPROM Microcomputer	\$ 9.95			
MC68705U3L	8-Bit EPROM Microcomputer	\$ 10.95			
MC68881RC12A	Floating Point Co-processor	\$ 199.95			

MICROPROCESSOR SALE!

Part No.	Price
MC68000L8	16-Bit MPU (8MHz) \$ 11.95
MC68000L10	16-Bit MPU (10MHz) \$ 14.95
MC68000L12	16-Bit MPU (12MHz) \$ 17.95
MC68008L8	32-Bit MPU (8-Bit Data Bus) \$ 19.95
MC68010L10	16-Bit MPU (10MHz) \$ 49.95
MC68020RC12B	32-Bit MPU (12MHz) \$ 199.95
MC68701	8-Bit EPROM Microcomputer \$ 9.95
MC68705U3L	8-Bit EPROM Microcomputer \$ 10.95
MC68881RC12A	Floating Point Co-processor \$ 199.95

COMMODORE CHIPS

Part No.	Price	Part No.	Price	
4116-15	16,384 x 1 (150ns)	89	WD1770.	14.95
4128-20	13,072 x 1 (200ns) (Pgyback)	3.25	SI-3052P.	5.95
4164-120	65,536 x 1 (120ns)	1.75	6502.	2.25
4164-150	65,536 x 1 (150ns)	1.15	6504A.	1.95
4164-200	65,536 x 1 (200ns)	.95	6507.	3.49
TMS4416-12	16,384 x 4 (120ns)	3.75	6510.	9.95
8118	16,384 x 4 (120ns)	.69	6520.	1.75
41256-120	262,144 x 1 (120ns)	3.75	6522.	2.95
41256-150	262,144 x 1 (150ns)	2.75	6525.	4.95
50664-15	65,536 x 4 (150ns) (4464)	4.95	6526.	14.95
511000P-10	1,048,576 x 1 (100ns) 1 Meg	27.95	6529.	2.95
514256P-10	262,144 x 4 (100ns) 1 Meg	29.95	6532.	6.49
STATIC RAMS				
2016-12	2048 x 8 (120ns)	1.69	6545-1.	2.49
TMM2018D-45	2048 x 8 (45ns)	6.95	6551.	3.29
2102-2L	1024 x 4 (250ns) Low Power	1.95	6560.	10.95
2114N	1024 x 4 (450ns)	.99	6567.	14.95
2114N-2L	1024 x 4 (200ns) Low Power	1.49	6569.	10.95
21C14	1024 x 4 (200ns) (CMOS)	.49	6572.	10.95
2149	1024 x 4 (450ns)	3.49	6581 (12V).	14.95
5101	256 x 4 (450ns) CMOS	1.95	6582 (9V).	14.95
6116P-3	2048 x 8 (150ns) CMOS	1.89	8360.	10.95
6116LP-3	2048 x 8 (150ns) LP CMOS	1.95	8501.	10.95
6264LP-12	8192 x 8 (120ns) LP CMOS	4.25	8502.	5.95
6264P-15	8192 x 8 (150ns) LP CMOS	3.59	8563.	15.95
6264LP-15	8192 x 8 (150ns) LP CMOS	3.75	8564.	12.95
6514	1024 x 4 (350ns) CMOS	3.95	8566.	15.95
43256-15L	32,768 x 8 (150ns) Low Power	17.95	8701.	9.95
EPROMS				
1702A	256 x 8 (1µs)	6.95	8721.	14.95
TMS2516	2048 x 8 (450ns) 25V.	4.95	8722.	7.95
TMS2532	4096 x 8 (450ns) 25V.	6.95	'251104-04.	10.95
TMS2532A	4096 x 8 (450ns) 21V.	6.49	318018-03.	15.95
TMS2564	8192 x 8 (450ns) 25V.	8.95	318019-03.	15.95
2708	1024 x 8 (450ns)	4.95	318020-04.	15.95
TMS2716	2048 x 8 (450ns) 3 Voltage	9.95	325302-01.	15.95
2716	2048 x 8 (450ns) 25V.	3.75	'325572-01.	24.95
2716-1	2048 x 8 (350ns) 25V.	4.95	'82S100PLA**	13.95
2716-2	2048 x 8 (450ns) 25V (CMOS)	6.49	901225-01.	11.95
2732	4096 x 8 (450ns) 25V.	3.95	901226-01.	11.95
2732A-20	4096 x 8 (200ns) 21V.	4.25	901227-03.	11.95
2732A-25	4096 x 8 (250ns) 21V.	3.95	901229-05.	15.95
2732C	4096 x 8 (450ns) 25V (CMOS)	6.49	*No specs available	
2764-20	8192 x 8 (200ns) 21V.	4.25	**Note 82S100PLA = U17 (C-64)	
2764A-25	8192 x 8 (250ns) 21V.	3.75		
2764A-25	8192 x 8 (250ns) 12.5V.	3.49		
2764.45	8192 x 8 (450ns) 21V.	3.29		
27C64-15	8192 x 8 (150ns) 21V (CMOS)	6.49		
27128-20	16,384 x 8 (200ns) 21V.	5.95		
27128-25	16,384 x 8 (250ns) 21V.	5.25		
27128-25	16,384 x 8 (250ns) 12.5V.	4.95		
27C128-25	16,384 x 8 (250ns) 21V (CMOS)	5.95		
27256-20	32,768 x 8 (200ns) 12.5V.	6.95		
27256-25	32,768 x 8 (250ns) 12.5V.	5.95		
27256-25	32,768 x 8 (250ns) 12.5V (CMOS)	8.95		
27512-25	65,536 x 8 (250ns) 12.5V.	16.95		
68764	8192 x 8 (450ns) 25V.	15.95		

Worldwide • Since 1974

• QUALITY COMPONENTS • COMPETITIVE PRICING
• PROMPT DELIVERY

Mail Order Electronics - Worldwide
Jameco
ELECTRONICS

Jameco General Purpose NEW! Prototype PC Boards

- Wire Wrap
- Component Testing
- Point-to-Point Wiring
- 31/62 Connection

JE417 (Pictured)
JE411 (6 1/2", No Pads, Gen. Purp.) . . . \$12.95
JE415 (6 1/2", No Pads, PC/XT) . . . \$14.95
JE417 (6 1/2", Plated w/Pads, PC/XT) . . . \$19.95

Extender Boards Designed for Troubleshooting and Testing

JE419 (5 1/2" Extender, 22/44 Connector) . . \$19.95
JE421 (4 1/2" Extender, 31/62 Connector) . . \$19.95

Commodore VIC-20 and C-64 Motherboards

CV64
May have to troubleshoot or just use for spare parts.
CV20 Includes: (1) 6560, (2) 6522, (1) 6502, (2) 6116P-4, and much more!
CV64 Includes: (1) 6567, (1) 6581, (1) 6510, (1) 82-S100PLA, (1) 901227-03, (2) 6526, and much more!

CV20 (VIC-20 Motherboard) . . . \$14.95
08903-3 (SAMS VIC-20 Schematics) . . . \$19.95
CV64 (C-64 Motherboard) . . . \$49.95
08906-8 (SAMS C-64 Schematics) . . . \$19.95

Additional Commodore Accessories

*CM-1 (300B Modem VIC-20, C-64) . . \$19.95
*JE232CM (RS232 Inter. VIC-20, C-64) . . \$39.95
CPS-10 (C-64 Power Supply) . . . \$39.95
CPS-128 (C-128 Power Supply) . . . \$59.95

ZUCKERBOARD TANDY 1000 Expansion Memory Half Card

Expand the memory of your Tandy 1000 (128K Version) to as much as 640K. Also includes DMA controller chip.
TAN-EM512K Includes 512K RAM . . . \$119.95
TAN-C Plug-in Clock option chip (only) \$39.95

SALE! 20Meg Hard Disk **SALE!**
T20MB 20MB Hard Disk Drive Board for Tandy 1000 . . \$579.95 \$494.95
SX20MB 20MB Hard Disk Drive Board for Tandy 1000SX \$589.95 \$499.95

TANDY 1000 Multifunction Board with Clock Calendar

Expand the memory on your Tandy 1000 (128K Version) to as much as 640K. Complete with an RS232 port, clock/calendar, RAM Disk, Printer Spooler and on-board DMA controller chip.
MTAN-512K Includes 512K RAM . . \$199.95

INTRODUCING JAMECO'S NEW COMPUTER KITS!!

Jameco's IBM™ AT Compatible Kit! Mini-286 6/8/10/12 MHz Kit!

Part No.	Description	Price
JE1015	XT/AT Style Keyboards	\$ 59.95
41256-120	512K RAM (18 Chips)	\$ 71.10
JE1012	Baby AT Flip-Top Case	\$ 79.95
JE1032	200W Power Supply	\$ 99.95
JE1022	5 1/4" High Density Disk Drive	\$119.95
JE1045	Hard Disk/Floppy Controller	\$199.95
JE1003	Baby AT Motherboard (Zero-K RAM-incl. Award BIOS ROM)	\$449.95

NEW! Regular List \$1,080.80
SAVE \$105.85!

JE1008 IBM™ AT Compatible Kit \$974.95
JE1059 EGA Monitor & Card **SAVE \$30.00** . . \$569.95

Jameco's IBM PC/XT Compatible Kit

Part No.	Description	Price
4164-150	128K RAM (18 Chips)	\$20.70
IBM-FCC	Floppy Controller Card	\$34.95
IBM-Case	Flip-Top Case	\$34.95
JE1015	XT/AT Style Keyboard	\$59.95
JE1030	150 Watt Power Supply	\$69.95
JE1050	Mono/Graph. Crd. w/Port	\$69.95
JE1020	5 1/4" DSDD Disk Drive	\$99.95
IBM-MON	12" Mono. Green Monitor	\$99.95
IBM-MB	XT Motherboard (Zero-K RAM-incl. DTK/ERSO BIOS ROM)	\$99.95

SAVE \$90.35
FREE! QUICKSOFT PC WRITE WORD PROCESSING SOFTWARE INCLUDED!

Regular List \$590.30
JE1004 (IBM™ PC/XT Compatible Kit) \$499.95

Jameco's 4.77/8MHz Turbo IBM Compatible Kit

Same as JE1004 except comes with 640K RAM, TURBO 4.77/8MHz motherboard, JE1071 multi I/O with controller and graphics, and AMBER monitor.

SAVE \$146.50 Regular List \$746.45
JE1005 (IBM™ PC/XT Turbo Compatible Kit) . \$599.95

IBM Compatible Motherboards

• 4.77/8MHz operation (Turbo only)
• 8087 Math Co-processor capability
• BIOS ROM included

TURBO 4.77/8MHz . . \$129.95 \$119.95
IBM-MB 4.77MHz . . . \$109.95 \$ 99.95

Additional Add-Ons Available!

Color Graphics Card for PC/XT/AT
• Text: 40 or 80 x 25 • Graphics: 320 or 640 x 200 • Manual included
JE1052 \$59.95

I/O Cards for PC/XT/AT
• Printer Port
• RS232 Port
• Game Port
• Manual included
JE1060 (Pictured) I/O for XT . . . \$69.95
JE1065 I/O for AT . . . \$69.95

EGA Card for PC/XT/AT
• Graphics: 720 x 348 • 16 out of 64 colors
• Manual included
JE1055 \$199.95

Multi I/O w/Controller & Graphics for PC/XT
• Printer port • RS232 port • Floppy controller
• Graphics • Manual included
JE1071 \$159.95

Jameco Solderless Breadboard Sockets

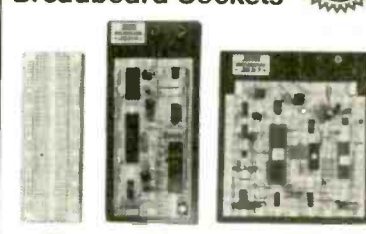

Part No.	Dim. L" x W"	Contact Points	Binding Posts	Price
JE20	6 1/2" x 3/8"	100	0	\$ 2.49
JE21	3 1/4" x 2 1/8"	400	0	\$ 4.95
JE22	6 1/2" x 1 3/8"	630	0	\$ 6.49
JE23	6 1/2" x 2 1/8"	830	0	\$ 7.49
JE24	6 1/2" x 3 1/8"	1,360	2	\$13.95
JE25	6 1/2" x 4 1/8"	1,660	3	\$24.95
JE26	6 1/2" x 5 1/8"	2,390	4	\$29.95
JE27	7 1/4" x 7 1/2"	3,220	4	\$39.95

Jameco Extended 80-Column Card for Apple IIe

• 80 Col./64K RAM • Doubles amount of data your Apple IIe can display as well as its memory capacity • Ideal for word processing • Complete with instructions

JE864 \$59.95
ADD-12 (Disk Drive II, II+, IIe) \$99.95

Additional Apple Compatible Products Available

NEW! Seagate 20, 30 & 40MB Half Height Hard Disk Drives

Part No.	Description	Price
ST225	20MB Drive only (PC/XT/AT)	\$274.95
ST225K	20MB w/Controller (PC/XT)	\$339.95
ST238K	30MB w/Cont. (PC/XT/AT)	\$399.95
ST251X	40MB w/Cont. Card (PC/XT)	\$599.95
ST251AT	40MB w/Cont. Card (AT)	\$659.95

Jameco PC/XT & AT Compatible Disk Drives

JE1020 (360K Drive, PC/XT/AT) . . . \$ 99.95
JE1022 (1.2MB, AT Compatible) . . . \$119.95

DATA BOOKS

30003	National Linear Data Book (82)	\$14.95
30005	Logic Data Book • Vol. II (84)	\$14.95
30009	Intersil Data Book (86)	\$ 9.95
30032	National Linear Supplement (84)	\$ 6.95
210830	Intel Memory Handbook (87)	\$17.95
230843	Intel Microsystem Hndbk. Set (87)	\$24.95

MUFFIN/SPRITE-STYLE FANS

MUF60	\$9.95
Torn Industries (4.68" sq, 60 cfm)	
SU2A1	\$8.95
EG&G Rotron (3.125" square, 20 cfm)	

\$20 Minimum Order — U.S. Funds Only
Shipping: Add 5% plus \$1.50 Insurance

California Residents: Add 6%, 6 1/2% or 7% Sales Tax
IBM is a registered trademark of International Business Machines

Data Sheets — 50¢ each
Prices Subject to Change

Send \$1.00 Postage for a
FREE Seasonal Flyer
FAX 415-592-2503
9/87



Send \$1.00 Postage for a
FREE 1988 CATALOG
Telex: 176043
©1987 Jameco Electronics

1355 SHOREWAY RD., BELMONT, CA 94002 • FOR ORDERS ONLY 415-592-8097 • ALL OTHER INQUIRIES 415-592-8121

TIMELINE INC.

20 MILLION I.C.'S IN STOCK!
Minimum I.C. Order: \$200.00

Continental U.S.A. **ORDER DESK ONLY** Inside California
(800) 872-8878 (800) 223-9977

L.A. & Technical Info
(213) 217-8912

OEM INQUIRIES WELCOME

"They say you can tell the men from the boys by the price of their toys. This is what they were talking about."

This amazing Laser array consists of a red (beam) light emitting Helium/neon gas filled laser. The laser tube is 15.5" long and 1.75" in diameter. The power supply for the laser outputs 12K volts at a maximum output power of 10 milliwatts. The laser beam is electronically modulated through an acoustic-optic modulator which causes it to scan back and forth by a rotating (500mph) polygonal mirror which is filtered through a special coated lens. The beam is directed by (5) special surface mirrors, (2) beam splitters and (3) special lenses. All parts are attached by optical mounts on a 18.5 lb. precision cast aluminum plate.

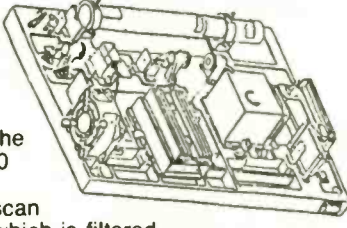

LASER ARRAY

FOR OPTICAL RESEARCH, DESIGN, ENGINEERING and EXPERIMENTER'S FANTASY

- | | |
|---------------------------------|--------|
| 1. LASER - (10 milliwatt) | 150.00 |
| 2. LASER Power Supply | 49.00 |
| 3. MIRRORS (5) SILVER | 79.00 |
| 4. LENSES (3) | 79.00 |
| 5. BEAM SPLITTERS (2) | 20.00 |
| 6. POLYGON MOTOR, LENS & DRIVER | 99.00 |
| 7. A-O MODULATOR A-O DRIVER | 99.00 |
| 8. LASER BRACKETS (2) | 15.00 |
| 9. SENSOR (2) | 10.00 |

\$499.00 KIT PRICE

ORIGINAL ASSEMBLY COST OVER \$5,000.00 FOR THIS LASER DECK

WARNING: Protective measures should be taken when using this equipment. **AVOID DIRECT EYE CONTACT AND EXPOSURE TO BEAM.** Buyers under 21 years of age are not allowed. I.D. necessary for purchase.

SEIKO 8650 Hard Disk Drives
10Mb FULL HEIGHT



\$89.00
10 Mb Formatted
8.2 Mb Unformatted

WITH OPTIONAL CONTROLLER CARD .. **\$169.00**
WITH RLL CARD **\$199.00**
(Comes out 12Mb Formatted with RLL CARD)
WITH SCUZI CONTROLLER..... **\$189.00**

FOUR PEN COLOR PLOTTER \$159.00
Ideal for architectural applications, CAD and graphic design. This color plotter will connect to the serial port of most microcomputers. The four color pens draw various shapes using ASC II commands. Enlarging and reducing is possible. A \$500.00 value. ONLY 30 available so call now.

"THE RETURN OF THE SPY IN THE SKY" **\$39.95**
4,096 Element Linear Image Sensor Driver Board Available

FULL HEIGHT HARD DISK DRIVES		
511-5 HITACHI \$499.00 53 Mb Unformatted 42 Mb Formatted 33 ms — average access time	3046 ATASI \$450.00 46 Mb Unformatted 39 Mb Formatted 33 ms — average access time	60 Mb Tape Backup FULL HEIGHT WANGTEK Model 5099EG24 \$249.00

FLOPPY DISC DRIVES	
TANDON — TM 55-4 96 t.p.i DS/DD, 5 1/4" \$69.00	REMEX — RFD480 2/3 ht., 360K DS/DD \$35.00
QUME — Track 142 1/2 ht. 360K DS/DD 5 1/4" \$65.00	SEIKO — 8640 Full Height 640K DS/DD (reads & writes 360K disks) \$35.00

IBM — Compatible Keyboards..... \$39.95
ZENITH — Green screen composite monitor (able to switch from 40 to 80 column and back)..... \$59.95
ASTEC — 65W switching power supply 5V @ 6A, + 12V @ 1.5A + 12V @ 2.1A, — 12V @ .25A..... \$29.00
PANAFLO — DC Brushless/0.12 Amps, 12 Volt Fan, 2-3/8" long by 1-1/4" deep, Model #FBP-06B12L..... \$12.95

HEWLETT-PACKARD/HBCS 4300/4500 Sapphire Tipped Industrial Digital Bar Code Wand. Hand held scanner. Reads all common bar code formats..... **\$69.00**

TRACKBALL — Ideal for use with Autocad. Downloadable parameters, Hi-Resolution (200 b.p.i.) Emulates: Summagraphics, Houston Instruments, Microsoft & Tektronix mouses. Features: Alternate cursor, downloadable auto-scaling and five general-purpose switches (instead of two)..... **\$89.00**

THE BEST COLOR GRAPHICS BUY OF THE CENTURY



\$699.00

INCLUDES: EGA CARD, MONITOR, CABLES & SOFTWARE
Call for Dealer Prices (10 or more)

BOARD FEATURES:
• Multiple Modes:

- CGA: 320 x 200 · ENHANCED TO 640x400
- EGA: 640 x 350 · ENHANCED TO 640x400
- **PGA RESOLUTION: 640x480** USING MICROSOFT WINDOWS, LOTUS, AUTOCAD, P CAD, ETC.
- HERCULES: 720x350
- AUTOSWITCH
- PARALLEL PRINTER PORT

MONITOR FEATURES:

- 13" DIAGONAL VIEWING AREA/NON-GLARE SCREEN
- MATRIX PITCH: 0.31mm/BLACK MATRIX
- ADDRESSABILITY: 640 HORIZONTAL x 480 VERTICAL
- PGA COMPATIBLE- OPERATES WITH SEPERATE RED, GREEN & BLUE ANALOG SIGNALS AND CAN SUPPORT AN INFINITE NUMBER OF COLORS.

If this monitor looks familiar, you have probably discovered one of the reasons why this is the best deal of the century. This incredibly built display was manufactured by the most prestigious company in the industry. Along with Classic Technology's™ new EGA adapter using Paradies™ single chip (PEGA II)™ combined with Paradies'™ BIOS, we are able to bring to market the most spectacular EGA package in the industry.

Imagine your CGA Software running at better than EGA Resolution

1490 W. ARTESIA BLVD., GARDENA, CA. 90247
Continental U.S.A. Inside California L.A. Area & Technical Info
(800) 872-8878 (800) 223-9977 (213) 217-8912
15% Restocking fee for returned orders
Inquiry 295

Minimum Order: \$25.00. Shipping & handling charges via UPS Ground: \$.50c/lb. UPS Air: \$1.00/lb. Minimum Charge: \$4.00. We accept cashiers checks, MC or VISA. No personal check COD's. Items reflect 5% cash or check discount. California residents add 6 1/2% sales tax. We are not responsible for typographical errors. All merchandise subject to prior sale. Phone orders welcome. Foreign Orders require special handling Prices subject to change without notice.



Why waste time?
ACCELERATE with VCACHE™

HARD DISK ACCELERATOR
 • Caching eliminates repetitive disk accesses
 • Use up to 15 Mb of extended/expanded or 500 Kb of standard memory

DISKETTE ACCELERATOR
SCREEN ACCELERATOR

FAST — FRIENDLY — SAFE

VCACHE
GOLDEN BOW SYSTEMS

\$49.95

Add \$3 for shipping/handling
 California residents add 6% sales tax



2870 Fifth Avenue Suite 201
 San Diego, CA 92103
619/298-9349

Inquiry 111

FIND THE WIDEST RANGE OF DP WORKSTATIONS, ACCESSORIES & SUPPLIES IN THIS FREE GLOBAL GUIDE



...all at **HUGE SAVINGS!**

The GLOBAL GUIDE offers more variety than any office equipment, computer or software dealer; plus, toll-free order convenience. Use the Reader Service Number or dial 1-800-8-GLOBAL (That's 1-800-845-6225).

GLOBAL
 COMPUTER SUPPLIES

45 South Service Road, Plainview, NY 11803

Inquiry 110

PC/XT USERS!

- COGTREE Utilities by Cogitate \$129.95
- LYNC by Norton-Lamber \$199.95
- DATAFLEX by Data Access... Varies
- RMICOBOL by Ryani
 McFarland Varies
- Universe by Omnitrend... \$ 98.50
- Blue MacI by Cogitate... \$599.00
- CadPower+ by Trilex... \$995.00
- Softest Teaching Aids... \$ 95.00
- PrintSet by Cogitate... \$ 79.95
- CogITAPE by Cogitate... CALLII
- Anti-Static Products... Varies
- Uninterruptible Power Backups... Varies
- TeleVideo Software... CALLII

COGITATE
 "A Higher Form of Software"
 24000 Telegraph Road
 Southfield, MI 48034
 (313) 352-2345/Telex 386581

VISA/MASTERCARD ACCEPTED
 Dealer Inquiries Welcomed

Inquiry 49

SCR The Smart Cash Register

- Cash Register/Point of Sale/Inventory
- 100% dBASE III data files
- Import into 1-2-3, Accounting, and most other programs
- Interface to Bar Code, Receipt Printer, Cash Drawer, Register

WE CARRY ALL HARDWARE, TOO!!!

ORDER NOW
 (915) 837-7180

SCR — Box 714
Alpine, TX 79831

Inquiry 258



UNIVERSAL EPROM PROGRAMMER KIT FROM \$95!!

- * On board power supply, 110/220 VAC;
- * Menu selection; No personality modules;
- * Built in monitor for easy I/O debugging;
- * User friendly softw; Full tech. support
- * Detailed 50 page manual with schematics;
- * Quick pulse algorithm: 27256 under 60 sec
- * All 24/28 pins to 27011 & CMOS E(E)PROMS
- * Micros: 8741, 2, 8748, 48H, 49, 49H & CMOS
- * Auto baud RS232 to 19.2k; Free PC drivers
- * Offset/split Hex, Binary, Intel & Motorola 8, 16 & 32 bit files; Cased unit \$495!

B&C Microsystems
 355 W. Olive Ave., Sunnyvale, CA 94086
 * Ph 408-730-5511 Visa & MC

Inquiry 36

SAVE ON

9 TRACK TAPE SYSTEM
 FOR IBM PC/XT/AT



- * Mainframe to PC Data Transfer
- * High Speed Backup
- * All Software, Complete System
- * Service and Support, easy Installation

call (818) 343-6505 or write to:
CONTECH Computer Corp.
 P.O. Box 153 Tarzana, Calif. 91356

CONTECH

Inquiry 67

maxell
 FLOPPY DISKS

5 1/4"	5 Box	10 Box
S-Side D-Den.	795	760
	<small>MIN 3 Bx</small>	730
D-Side D-Den.	995	930
	<small>MIN 3 Bx</small>	875
HIGH Density	1795	1700
	1660	

S-SIDE 96TPI	2 Box	15 ⁹⁵	D-SIDE 96TPI	2 Box	19 ⁹⁵
--------------	-------	------------------	--------------	-------	------------------

3 1/2" S-Side	10 ⁸⁰	(3 1/2")	3 1/2" D-Side	15 ⁹⁵
---------------	------------------	----------	---------------	------------------

S-Side	19 ⁹⁵	(8")	D-Side	21 ⁹⁵
D-Den.			D-Den.	

Old Number: Delaware 1-800-451-1849
 P.O. BOX 10247, WILMINGTON, DE 19800
 Oklahoma 1-800-654-4058
 P.O. BOX 1074, BE THANY, OK 73008
 Nevada 1-800-621-6221
 P.O. BOX 12398, LAS VEGAS, NV 89112

Minimum Order \$25.00. Visa, MasterCard accepted. C.B. orders add \$3.00 Surface Shipping. * \$3.00 S.S. add \$3.00 per 100 disks. * \$4.00 per 100 disks. * \$5.00 delivery only. U.S. only for 5 1/4" FPK, 8", 8" or 5 1/4" add an additional 5% for P&H. Prices subject to change without notice!

Verbatim.

5 1/4"	5 BOX	10 BOX
S-Side D-Den.	795	780
	<small>MIN 3 Bx</small>	775
D-Side D-Den.	995	930
	<small>MIN 3 Bx</small>	895
High Den.	1795	1700
	1660	

3 1/2" Diskettes
 S-Side 11⁹⁵ D-Side 16⁵⁰

8" Diskettes
 S-Side 15⁴⁰ S-Side 17⁹⁵ D-Side 20⁹⁵
 S-Den. D-Den.

Old Number: Delaware 1-800-451-1849
 P.O. BOX 10247, WILMINGTON, DE 19800
 Oklahoma 1-800-654-4058
 P.O. BOX 1074, BE THANY, OK 73008
 Nevada 1-800-621-6221
 P.O. BOX 12398, LAS VEGAS, NV 89112

Minimum Order \$25.00. Visa, MasterCard accepted. C.B. orders add \$3.00 Surface Shipping. * \$3.00 S.S. add \$3.00 per 100 disks. * \$4.00 per 100 disks. * \$5.00 delivery only. U.S. only for 5 1/4" FPK, 8", 8" or 5 1/4" add an additional 5% for P&H. Prices subject to change without notice!

3M

5 1/4"	5 Box	10 Box
S-Side D-Den.	795	780
	<small>MIN 3 Bx</small>	775
D-Side D-Den.	995	930
	<small>MIN 3 Bx</small>	875
HIGH Den.	1795	1700
	1660	

S-Side 96tpi	1575	D-Side 96tpi	1995	LANIER NP	2595
--------------	------	--------------	------	-----------	------

3 1/2" S-Side	1195	DC 100A	12.95	8" S-Side	1540
		DC 1000	12.95	S-Den.	
3 1/2" D-Side	1650	DC 2000	17.50	8" S-Side	1895
		DC 300A	16.50	D-Den.	
3 1/2" H-Den.	4995	DC 300 XLP	19.75	8" D-Side	2095
		DC 800 A	21.95	D-Den.	

Old Number: Delaware 1-800-451-1849
 P.O. BOX 10247, WILMINGTON, DE 19800
 Oklahoma 1-800-654-4058
 P.O. BOX 1074, BE THANY, OK 73008
 Nevada 1-800-621-6221
 P.O. BOX 12398, LAS VEGAS, NV 89112

Minimum Order \$25.00. Visa, MasterCard accepted. C.B. orders add \$3.00 Surface Shipping. * \$3.00 S.S. add \$3.00 per 100 disks. * \$4.00 per 100 disks. * \$5.00 delivery only. U.S. only for 5 1/4" FPK, 8", 8" or 5 1/4" add an additional 5% for P&H. Prices subject to change without notice!

DIGITAL and ANALOG I/O

for the

IBM PC, XT, AT

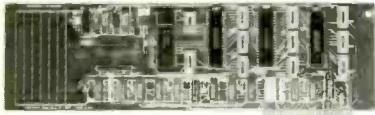

UNIVERSAL I/O

This board has three 8255 VIA's that make up the nine 8 bit I/O ports. That's 72 I/O lines! This board also has 16 ANALOG inputs. Each input has a 0 to 5 volt range, 8 bit resolution (256 steps), 20 meg input impedance. Conversion time is 200 us per channel. A DIP switch is used to select the I/O address. This board also has a prototype area.

ORDER part # 83-064A \$229.95



PARALLEL I/O

This board has two 8255 VIA's that make up six 8 bit parallel I/O ports. That's 48 I/O lines!

ORDER part # 86-108A \$99.95

Free Catalog!

To get a FREE CATALOG of JBE products send a label with your name and address and I will stick it on a catalog and send it to you. I also make I/O boards for Apple computers and single board control computers.



JOHN BELL ENGINEERING, INC.
400 Oxford Way, Belmont, CA 94002
(415) 592-8411 9am to 4pm Pacific time.

VT220 Emulation Software and Keyboard

A Complete VT220 Work Station Upgrade for the IBM PC/XT/AT

PowerStation™ 220 \$289

KEA Systems Ltd.
#412 - 2150 West Broadway
Vancouver, B.C. Canada V6K 4L9
Support (604) 732-7411
TELEX 04-352848 VCR FAX (604) 732-0715
Order Desk (800) 663-8702 Toll Free
30 day money back guarantee. MC/VISA

Inquiry 145

PAL Programmer

- Works with PC XT/AT
- Programs 20 & 24 pin MMI, NS TI PAL
- Support JEDEC format
- Security Fuse Blow
- DIR, LOAD, SAVE, EDIT, BLANK CHECK, READ, WRITE, VERIFY FUNCTION
- High yield, very reliable
- S/W Included

\$395

*EPROM programmer (1, 4, 8 socket) \$195
Supports 24-32 pin EPROM, CMOS EPROM, EEPROM
-27(C)16-27(C)512, 27513, 271000, 27301, 2864A
-Program 27C256 only 30 sec with Outclk-pulse
-Vcc=5, 6, 6.25V Vpp=5, 12.5, 12.75, 13, 21, 25V

*8741/42/48/49 programmer \$245
*TTL IC & MEMORY TESTER \$245
*BIPOLAR ROM programmer \$395
*68000 Single Board Computer \$395

XELTEK
(408) 727-6995

473 Sapena Ct. CA residents add 6.5% tax.
Unit 24 Add \$5 for S/H
Santa Clara, CA 95054

Inquiry 319

The **GRANDSTAND** PRINTER STAND AND TRAY

- Folds & Stacks Automatically
- Fits ALL Popular Micro Printers
- Space Saving Operation
- Routes Cables Neatly

Grand Union
Micro Systems
P.O. Box 1880
Fallbrook, CA 92028
(619) 723-0882

Inquiry 114

ENHANCED VT220 \$150

System by **KEA**

The most complete VT220 emulation available for your PC/XT/AT or compatible.

- HIGH PERFORMANCE to 38.4K BAUD
- TRUE DOUBLE HIGH/DOUBLE WIDE
- TRUE 132 COLUMN MODE ON MOST EGA'S
- COLOR EXTENSIONS/DOWNLOADABLE FONTS
- SOFTKEY/MACROS, DOS ACCESS
- XMODEM/KERMIT FILE TRANSFERS plus many more extensions!

ZSTEMpc™-VT220 Emulator \$150.
with PowerStation™220 layout keyboard \$289
EGAmate™ option for true EGA 132 column \$399
ZSTEMpc™ - 4014 option \$99

KEA Systems Ltd.
#412 - 2150 West Broadway
Vancouver, B.C. Canada V6K 4L9
Support (604) 732-7411
TELEX 04-352848 VCR FAX (604) 732-0715
Order Toll Free (800) 663-8702
30 day money back guarantee. MC/VISA

Inquiry 146

PROUDLY PRESENTS

- **Dual SIO Serial Interface.** Two independent 8250/16450 ports, COM1-N, versatile, RTS and CTS. RS-232/ 422/ 485/ 449 compatible.
- **ACB-II Advanced Communications Board.** SYNC/ASYNC to 880K, OMA, 82530 SCC, RTS, CTS, RXC, TXC signals. RS-232/ 422/ 485/ 449 compatible.

SEALEVEL SYSTEMS INC.
PO BOX 1808
EASLEY, SC 29641 USA
(803) 855-1581

Inquiry 261

PC-AT TURBO COMPLETE SYSTEM \$1139.00
640K RAM/1.2M floppy drive/HDD-FDD controller/Monochrome card/Monochrome monitor/200W powersupply/AT style keyboard.

PC XT TURBO COMPLETE SYSTEM \$659.00
640K RAM/2 floppy drives/Monochrome monitor/Monochrome card/150W powersupply/AT style keyboard/Phoenix Bios

PC-XT TURBO W/20MB HARD DRIVE \$927.00
640K RAM/1 floppy drive/Monochrome monitor/Monochrome card/150W power supply/AT style keyboard/Phoenix Bios

FREE SOFTWARE WITH PURCHASE OF HARDDRIVE SYSTEM

ORDERS
Nationwide Toll Free 1-800-331-0488
Inquiries/Support 1-305-296-6083

Sai Systems Laboratories, Inc.
103 Fitzpatrick Street
Key West, Fla. 33040

Inquiry 255

The Amazing A-BUS

NEW

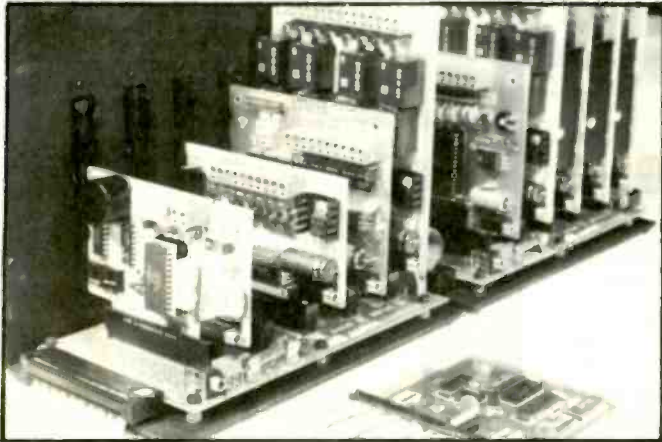

An A-BUS system with two Motherboards
A-BUS adapter (IBM) in foreground

Plug into the future

With the A-BUS you can plug your PC (IBM, Apple, TRS-80) into a future of exciting new applications in the fields of control, monitoring, automation, sensing, robotics, etc.

Alpha's modular A-BUS offers a proven method to build your "custom" system today. Tomorrow, when you are ready to take another step, you will be able to add more functions. This is ideal for first time experimenting and teaching.

A-BUS control can be entirely done in simple BASIC or Pascal, and no knowledge of electronics is required!

An A-BUS system consists of the A-BUS adapter plugged into your computer and a cable to connect the Adapter to 1 or 2 A-BUS cards. The same cable will also fit an A-BUS Motherboard for expansion up to 25 cards in any combination.

The A-BUS is backed by Alpha's continuing support (our 11th year, 50000 customers in over 60 countries).

The complete set of A-BUS User's Manuals is available for \$10.

About the A-BUS:

- All the A-BUS cards are very easy to use with any language that can read or write to a Port or Memory. In BASIC, use INP and OUT (or PEEK and POKE with Apples and Tandy Color Computers)
- They are all compatible with each other. You can mix and match up to 25 cards to fit your application. Card addresses are easily set with jumpers.
- A-BUS cards are shipped with power supplies (except PD-123) and detailed manuals (including schematics and programming examples).

Relay Card

RE-140: \$129

Includes eight industrial relays (3 amp contacts, SPST) individually controlled and latched. 8 LED's show status. Easy to use (OUT or POKE in BASIC). Card address is jumper selectable.

Reed Relay Card

RE-156: \$99

Same features as above, but uses 8 Reed Relays to switch low level signals (20mA max). Use as a channel selector, solid state relay driver, etc.

Analog Input Card

AD-142: \$129

Eight analog inputs. 0 to +5V range can be expanded to 100V by adding a resistor. 8 bit resolution (20mV). Conversion time 120us. Perfect to measure voltage, temperature, light levels, pressure, etc. Very easy to use.

12 Bit A/D Converter

AN-146: \$139

This analog to digital converter is accurate to .025%. Input range is -4V to +4V. Resolution: 1 millivolt. The on board amplifier boosts signals up to 50 times to read microvolts. Conversion time is 130ms. Ideal for thermocouple, strain gauge, etc. 1 channel. (Expand to 8 channels using the RE-156 card).

Digital Input Card

IN-141: \$59

The eight inputs are optically isolated, so it's safe and easy to connect any "on/off" devices, such as switches, thermostats, alarm loops, etc. to your computer. To read the eight inputs, simply use BASIC INP (or PEEK).

24 Line TTL I/O

DG-148: \$65

Connect 24 input or output signals (switches or any TTL device) to your computer. The card can be set for input, latched output, strobed output, strobed input, and/or bidirectional strobed I/O. Uses the 8255A chip.

Clock with Alarm

CL-144: \$89

Powerful clock/calendar with battery backup for Time. Date and Alarm setting (time and date); built in alarm relay, led and buzzer; timing to 1/100 second. Easy to use decimal format. Lithium battery included.

Touch Tone® Decoder

PH-145: \$79

Each tone is converted into a number which is stored on the board. Simply read the number with INP or POKE. Use for remote control projects, etc.

A-BUS Prototyping Card

PR-152: \$15

3 1/2 by 4 1/2 in. with power and ground bus. Fits up to 10 I.C.s

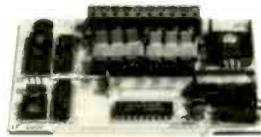

ST-143

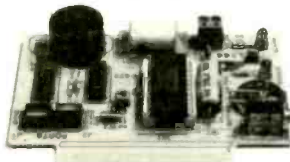

CL-144



RE-140

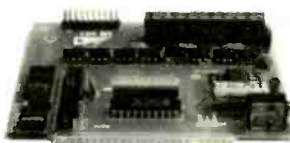

IN-141

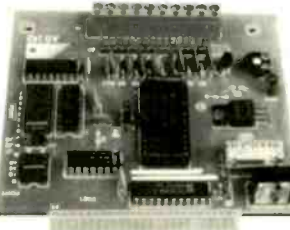

AD-142

Smart Stepper Controller SC-149: \$299

World's finest stepper controller. On board microprocessor controls 4 motors simultaneously. Incredibly, it accepts plain English commands like "Move arm 10.2 inches left". Many complex sequences can be defined as "macros" and stored in the on board memory. For each axis, you can control: coordinate (relative or absolute), ramping, speed, step type (half, full, wave), scale factor, units, holding power, etc. Many inputs: 8 limit & "wait until" switches, panic button, etc. On the fly reporting of position, speed, etc. On board drivers (350mA) for small steppers (MO-103). Send for SC-149 flyer.

Remote Control Keypad Option RC-121: \$49
To control the 4 motors directly, and "teach" sequences of motions.

Power Driver Board Option PD-123: \$89

Boost controller drive to 5 amps per phase. For two motors (eight drivers).

Breakout Board Option BB-122: \$19

For easy connection of 2 motors, 3 ft. cable ends with screw terminal board.

Stepper Motor Driver ST-143: \$79

Stepper motors are the ultimate in motion control. The special package (below) includes everything you need to get familiar with them. Each card drives two stepper motors (12V, bidirectional, 4 phase, 350mA per phase). **Special Package: 2 motors (MO-103) + ST-143: PA-181: \$99**

Stepper Motors MO-103: \$15 or 4 for \$39

Pancake type, 2 1/4" dia. 1/4" shaft, 7.5"/step, 4 phase bidirectional, 300 step/sec. 12V, 36 ohm, bipolar, 5 oz-in torque, same as Airpak K82701-P2.

Current Developments

Intelligent Voice Synthesizer, 14 Bit Analog to Digital converter, 4 Channel Digital to Analog converter, Counter Timer, Voice Recognition.

A-BUS Adapters for:

IBM PC, XT, AT and compatibles. Uses one short slot	AR-133...\$69
Tandy 1000, 1000 EX & SX, 1200, 3000. Uses one short slot	AR-133...\$69
Apple II, II+, IIe. Uses any slot	AR-134...\$49
TRS-80 Model 102, 200. Plugs into 40 pin "system bus"	AR-136...\$69
Model 100. Uses 40 pin socket (Socket is duplicated on adapter).	AR-135...\$69
TRS-80 Mod 3.4.4 D. Fits 50 pin bus (With hard disk use Y-cable).	AR-132...\$49
TRS-80 Model 4P. Includes extra cable. (50 pin bus is recessed).	AR-137...\$62
TRS-80 Model I. Plugs into 40 pin I/O bus on KB or E/I.	AR-131...\$39
Color Computers (Tandy). Fits ROM slot. Multipak or Y-cable.	AR-138...\$49

A-BUS Cable (3 ft, 50 cond.) CA-163: \$24

Connects the A-BUS adapter to one A-BUS card or to first Motherboard. **Special cable for two A-BUS cards: CA-162: \$34**

A-BUS Motherboard MB-120: \$99

Each Motherboard holds five A-BUS cards. A sixth connector allows a second Motherboard to be added to the first (with connecting cable CA-161: \$12). Up to five Motherboards can be joined this way to a single A-BUS adapter. Sturdy aluminum frame and card guides included.

Add \$3.00 per order for shipping. Visa, MC, checks, M.O. welcome. CT & NY residents add sales tax. C.O.D. add \$3.00 extra. Canada: shipping is \$5. Overseas add 10%



ALPHA Products

242-B West Avenue, Darien, CT 06820

Technical info: (203) 656-1806
Orders only 800 221-0916
Except in CT
Connecticut orders: (203) 348-9436
All lines open weekdays 9 to 5 Eastern time

DiskMASTER[®]
The Ultimate
Diskette Value ...



Discover the
Difference ...

2 FOR 1 LIFETIME WARRANTY

- ✓ Backed by 2 for 1 Lifetime Warranty
- ✓ 100% tested and certified
- ✓ Made to exceed A.N.S.I. specs by 62.5% with a guaranteed clipping level of 65% or above
- ✓ Packaged in 6 different colors, bulk or boxed
- ✓ Includes tyvek envelopes (not paper), write protect tabs and user labels
- ✓ Brand-name quality at affordable prices

NOW IN
COLOR

.49 BULK
COLOR
OR GRAY **1.09**

.59 BOXED
COLOR **1.19**

5-1/4" - 48 TPI DS-HD 96 TPI
DS-DD IBM-AT Compatible

Simply top Brand-Name Quality, made in the U.S.A. by a leading manufacturer. Factory polybagged in lots of 20 (min order 40)

YCENTECH[®] America's
Premium Quality
Color Diskettes

- ✓ TIMELESS WARRANTY
- ✓ Performance exceeds A.N.S.I. spec. by 88%
- ✓ Each disk 100% tested and certified
- ✓ 14 COLORS for data organization
- ✓ Pkgs. of 10 tyvek sleeves, w/p tabs, & ID labels

5-1/4" - 48 TPI DS-HD 96 TPI
DS-DD IBM-AT Compatible

.97 PLASTIC STORAGE BOX
COLOR **1.85**

.77 BULK
COLOR **1.75**

3-1/2" Color, DS, 135 TPI
Plastic Storage Box **1.79**

3M America's No. 1
Name-Brand
Diskettes



5-1/4" - 48 TPI DS-HD 96 TPI
DS-DD IBM-AT Compatible

.84 **1.77**

With FREE Platen Cleaner

Nashua

5-1/4" - 48 TPI DS-HD 96 TPI
DS-DD IBM-AT Compatible

.54 **1.45**

BULK

32¢ 5-1/4" DS/DD 48 TPI
Exceeds ANSI specifications
+ 6¢ FOR TYVEK

ORDERING INFORMATION

TERMS: Free use of VISA, Mastercard, and American Express. P.O. orders accepted from recognized corporations rated 3A2 or better, government and schools on net 30. **SHIPPING:** U.S. orders add \$3.00 per 100 diskettes or fraction thereof, add \$5.00 for COD orders.

PRICE PROMISE: We will better any lower delivered price on the same products and quantities advertised nationally.

Toll Free Order Line: **1-800-233-2477**
Information Line: **1-801-561-0092**



199 COTTAGE AVE.
SANDY, UTAH 84070
HOURS: 8 AM TO 5 PM
(MTN. TIME)

**EASY TESTING & REWIRING
OF RS-232 INTERFACES!
B & B ELECTRONICS "BUDGET
BREAK-OUT BOX"**

- opens signal lines
- monitors RS-232 signals
- re-wires lines

\$49.95



Ideal for troubleshooting, Break-out Box Model 232MAB incorporates nine 2-color LED's for monitoring TD, RD, RTS, CTS, DSR, CD, and DTR, plus 2 spare LED's.

Includes one male and one female RS-232 connector, requires no AC power or batteries. Also includes 24-page instruction manual. Order direct from Manufacturer **TODAY and SAVE!** **SAME-DAY SHIPMENT! MONEY-BACK GUARANTEE!**

Request your **FREE B & B ELECTRONICS Catalog**, with a complete line of RS-232C interface and monitoring equipment.

*Terms: Visa, MC, cash orders postage. PO's from qualified rates. Terms accepted. & residents add 5% tax.



1502J Boyce Memorial Drive • P.O. Box 1008 • Ottawa, IL 61350
Phone: 815-434-0846

ORDER
TODAY!

Inquiry 35

**Scientific Subroutine and
Graphics Libraries**

Turbo Pascal, Lightspeed Pascal and Modula 2
IBM PC, AT's and Macintosh

FFT's — Forward, inverse, 2-D, power spectrum and Hamming, Hanning, Welch, Parzen and Blackman windows
Roots — Bisection, Brent's and Newton's methods
Eigenvalues and vectors — Cyclic Jacobi
Complex Number Math — Simultaneous equations, matrix math, polar conversion

Curve Fitting — Polynomial and cubic splines
Special Functions Library — Hyperbolic trig, Error, Gamma, Beta, Hermite, Laguerre, Jacobi, Chebyshev, Legendre, Bessel and many more

Differential Equations — Runge-Kutta-Fehlberg
Statistics, Matrix Math, Solution of Equations
Integration, Multiple Regression and Linear Programming

Engineering Graphics — Line plots, bargraphs, scatter plots with linear, semilog and full log scaling, Automatic graph scaling with arbitrary x and y axis intercepts. Also includes 3-D plotting, (CGA, EGA hires, Hercules compatible on IBM machines).

Includes manual and source code

IBM PC, AT Versions	Model #	Price
Turbo Pascal	IPC-TP-006	\$75.00
Logitech Modula 2	IPC-M2-006	\$75.00

Apple Macintosh Version
Turbo Pascal, Lightspeed Pascal MAC-LP-006 \$75.00
Order any two for \$125

To Order: Call (617) 444-7721 or write Quinn-Curtis, 49 Highland Ave., Needham, MA 02194. Mastercard, Visa, Company PO's, Personal checks and COD orders accepted. Add \$5 for shipping outside of North America. Send for our free catalogue of software products.

Inquiry 248

**REAL WORLD I/O
For PC/XT/ATs**

AD200 - 4 channel, 12-bit A/D board, 10 kHz sampling rate, instrumentation amp front end. \$239



ADA300 - 8 channel, 8-bit A/D; single D/A; 24 programmable digital I/O lines. \$239

AD500 - 8 channel, 12-bit A/D board. Software programmable gains of 1, 10, and 100. Highly accurate integrating converter. 7 digital I/O lines. High-Z inputs. \$239

AD100 - Single channel version of AD500. 10 digital I/O lines. Same accuracy and programmable gains. \$149

DA600 - Fast settling 12-bit dual D/A converter. \$169

DG24 - Digital I/O board with 24 TTL lines configurable in software. \$95

XB40 - Easy connect extender/prototype board with terminal strips. \$49

OEM discounts available.

Real Time Devices, Inc.



1930 PARK FOREST AVENUE
P.O. BOX 906
STATE COLLEGE, PENNSYLVANIA 16804

(814) 234-8087

68020

QT 20x, the low cost 68020 based multi-user, multi-tasking computer that supports from 2 to 30 users and .5 to 14.5 megabytes of RAM is now available!!!

The *QT 20x* has a 12.5 MHz 68020 microprocessor with 2 serial ports, 1 parallel port, a real time clock with battery backup, 68881 math co-processor option and full SCSI interface with DMA and floppy controller with DMA. Bundled software includes OS9/68020 Professional Operating System with Basic and C plus backup and communications. Up to seven plug-in boards with 2 Megabyte RAM and 4 serial ports each can be installed.

Prices start at \$2195.00 Board level to complete systems are available.

FRANK HOGG LABORATORY, INC.
770 JAMES STREET
SYRACUSE, NEW YORK 13203
315/474-7856 TELEX 646740

Inquiry 102

**Motion Control &
Data Acquisition**



On your IBM PC or Apple II and all compatibles

Smart 2 Axis Motion Controller: For many types of motors & encoders. New I.C. (from HP) allows changes & monitoring on the fly. Optically isolated. V/SOFTWARE \$400.

Four Axis Stepper Driver: With SOFTWARE & motor for instant automation. \$95.

Fast A/D Board: With programmed gain, 650 KHz, 4 inputs, \$220. Complete Scope hardware & SOFTWARE \$500. Also: 12 Bit A/D, Relay Driver, Real Time Clock. Circuit developers Project Book \$25.

How do you do it? Use our Local Applications Bus, LAB 40. One host adapter (\$150) supports up to 8 boards, like those above, on a 50 ft. ribbon cable.

Please call (415) 755-1978 for free literature.

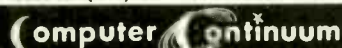

75 Southgate Ave., Suite 6
Daly City, CA 94015 (415) 755-1978

BIG MOUTH[™]

REAL VOICE Digital Recording
for your PC, XT, AT or Compatible

- ◆ **Dynalite Answering Machine**
- Toll-saver, message forw., wake-up calls, touchtone remote and much, much more
- ◆ **Timesaving Voice Mail System**
- ◆ **Hooks Up To Alarm & Detec. Systems**
- Instantly alerts authorities
- ◆ **Built-in Autodialer with Database**
- No modem necessary
- ◆ **Voicepad™**
- Voice memos & dictation at your fingertips
- ◆ **Bull's-Eye Telemarketing**
- ◆ **Optional Programmer's Toolkit**
- Voice & Sound Effects for your programs, demos and tutorials

Complete with Hardware 1/2 card, software, phone cable, and external speaker

\$239⁰⁰ + \$5 s/h
(415) 339-TALK

Talking Technology, Inc.
6558 Lucas Ave. Suite 301
Oakland, CA 94611

California Digital

17700 Figueroa Street • Carson, California 90248



\$129

PLOTTER

The Sweet "P" 100 was private labeled for the Epson corporation under the Comex Brand. This plotter makes short work of translating financial and numeric data into a graphic presentation. Many ready to run programs such as AutoCAD and Lotus 1-2-3 already support this plotter.

The Sweet "P" 100 features programmable paper sizes up to 8 1/2 by 120 inches, 6 inch per second plot speed and 0.004" step size. Easy to implement Centronics interface allows the Sweet "P" 100 immediate use with the printer port of most personal computers.

This is your opportunity to purchase a plotter which was originally priced at \$795 for only \$129.

Also available is a support package which includes demonstration software, interface cable, a multicolor pen assortment and a variety of paper and transparency material.

Model	Price	Model	Price
Bestall "P" 100 Comex 8 1/2 by 120"	\$129	Richard DYN 880 11 by 17 multi-pan	\$129
Houston Instruments DMP750 11 by 17	\$795	ColComp 104001 11 by 17	\$129
Houston Instruments DMP70 11 by 17 8 1/2 by 38	\$795	Hewlett Eiger Tablet 11 by 17	\$69
Houston Instruments DMP111 8 1/2 CD 24 by 38	\$795	Summagraphics Burnmaster 12" 4 button	\$119
Houston Inst. DMP100 11 by 17 8 1/2 by 38	\$695	Summagraphics Burnmaster 100 line	\$89
Houston Instruments DMP111 8 1/2 by 38 by 44	\$795	Microsoft serial mouse with spare track	\$39
Houston Inst. PC386 11 by 17 multi-pan	\$79	Microsoft serial mouse opto-ergonomic brush	\$29



\$1595

20/20 Bernoulli Box

California Digital has purchased these 20/20 Bernoulli systems from Iomega. The units needed some minor alignment and had to be sent back to Iomega. These have to sold as an accident/used... but for all practical purposes they are new and come with a one year Iomega factory warranty.

The 20/20 Bernoulli Box features removable cartridges, and delivers reliability, expandability, transportability, security and speed in one versatile subsystem. It lets you transfer megabytes of information safely and swiftly for primary or backup storage. Or combine several software programs onto a single cartridge for easy switching from one to another.

Reliable... the Box has incredible resistance to shock and vibration... completely eliminating the possibility of head crash.

Security essential?... Don't lock up your system... just lock up the cartridges.

20+20 Subsystem... \$1595; Non bootable controller... \$159;
Bootable controller... \$189; 20 Megabyte Cartridges... \$69.



\$35

We have them again... The Remex 480 was a sell out two years ago but we located an additional 10,000 units and are offering these 2 3/4 height IBM/PC compatible 360K/Byte drives at only \$35 each at quantity two.

\$115

The Panasonic 475 is jumper selectable between 96 TPI format and 1.2 Megabyte as used in the IBM/AT computer.

Suggested price of the 475 is \$189 but California Digital located a computer manufacturer that had to liquidate stock making available 1000 of these choice drives. Quantity two \$115 each.

	One	Two	Ten
REMX 480 3/4 height for PC	39	35	call
TANDON 65L/2 360K, 1/2 ht.	79	75	72
MITSUBISHI 4853 96 TPI.	99	95	92
MITSUBISHI new 501 half ht.	119	109	105
MITSUBISHI 504A AT comp.	149	139	135
TEAC FD55BV half height	109	99	89
TEAC FD55FV 96 TPI, half ht.	119	109	105
TEAC FD55GF for IBM AT	149	139	135
PANASONIC 455 Half Height	109	99	89
PANASONIC 475 1.2 Meg./96	119	115	109
Switching power supply			49
Dual enclosure for 5 1/4" drives			59



SONY

\$139

The Sony 53W is a 3 1/2 inch double sided double density disk drive. The drive can be connected to your existing floppy controller but will require MS/DOS 3.2 to properly operate in the PC and compatibles. The 53W is similar to the drive being used in the PC portable.



Free Interface Kit

~~\$2495~~ **\$759**

80 Character Daisy Wheel Printer

These Fujitsu Daisy Max 830 were manufactured for Motorola's Computer Division. The purchase order was canceled and Fujitsu was forced to liquidate these 80 character per second daisy wheel printers at "fire sale" prices.

Features: bullet proof construction, serial RS-232C interface, Diablo 830 wheels and commands, programmable line spacing in increments of 1/96" and column spacing of 1/120". The printer is also capable of underscoring, bold overprint, shadow print, centering and justifies along with vector plotting.

Factory suggested price of the Daisy Max 830 was \$2495. California Digital is offering this liquidated special at only \$759 and including FREE a serial card kit with cable. Also available: tractor and sheet feeders.

PRINTERS

IBM Thermal printer, 80 cps, serial	\$39	Panasonic P1582 15" x 180 cps	239
Fujitsu D630 80 cps, daisy wheel serial	759	Star Gemini NX10, 120 cps 15" NLO	239
Silver Reed EXP-800 136 cps, 40 cps	729	Star Gemini NX15, 120 cps 15" NLO	259
Julia 6300 daisy wheel 40 cps	819	Toshiba 321, 24 wire head 216 cps, NLO	579
NEC 8850 Superwriter daisy wheel 55 cps	1159	Toshiba 341, 24 wire head 216 cps, 15"	629
NEC PB/660P 10" 216 cps NLO	469	Printronic P300 dot matrix, 300 LPM	3995
NEC P7760P 15" 216 cps NLO	659	Printronic P800 dot matrix, 600 LPM	5795
Epson FX80E NLO 10" 240 char./sec.	299	DataProducts 8800/3 hard pt, 600 LPM	6985
Epson FX286E NLO 15" 240 char./sec.	539		
Epson EX1000 300 cps, NLO/54 cps	599		
Citizen MSP-10 160 cps 10"	299	Apple Laser Writer Plus; Postscript	4295
Citizen MSP-15 160 cps 15"	449	AMS PS/800 2 meg Postscript, 8 pgs.	4295
Okidata 162 80 column, part I	239	Hewlett Packard Series II laser printer	1795
Okidata 182+ 136 column, part I	345	Texas Instr. OmniLaser 2108 P/S, 8 pgs.	4295
Okidata 252 136 column, parallel	469	Texas Instr. OmniLaser 2115 P/S, 16 pgs	5595
Panasonic P1080L 10" 120 cps	229	Quadram QuadLaser 5 Megabytes	2995
Panasonic P1091L 10" 160 cps	299	AST TurboLaser, 8 pages/minute	3195



HEWLETT PACKARD

LASER JET II

\$1795

Standard features of the new Hewlett Packard Series II Laser printer: 512 K byte memory expandable to 4 Megabytes, both serial and parallel ports. List price \$2495; California Digital price \$1795. Memory upgrade, type fonts and toner cartridges available.

Other Laser Printers available:

Texas Instruments • Okidata • Apple • Ricoh
Gume • AST Research • OMS • Xerox • Canon
Quadram • Centronics • CIE C.Itoh • DataProducts



COLOR GRAPHICS TERMINAL

\$3995

\$659

The Lear Siegler 7107 color graphics terminal is both DEC (VT-100 / VT-51) and Tektronix (4010/4014) compatible. The terminal offers a palette of 4,096 colors with a resolution of 640 by 480 pixels on a 13 inch non-glare black screen. Horizontal pan and image zoom, to 16 times original size, are standard features of this color graphics terminal. The 7107 is the ideal terminal for CAD/CAM applications.

NOW YOUR COMPUTER CAN READ!

Omni-Reader... the first optical character reader designed and priced for the small computer

\$159

COPY:
- Manuscripts - Contracts - Articles
- Forms - Invoices

APPLICATIONS:
- Mailing Lists - Editing - Data Base Management
- Transferring information between incompatible systems

Uses a standard RS-232 serial port hookup to interface easily with your computer.



21 Megabyte Gold Card

\$459

Also available 31 Megabytes at only \$559.

The fastest, lowest powered, lowest warranted, most durable, highest capacity, most reliable, lowest priced HARD-DISK-ON-A-CARD available in the world today.

1.6ms Access Time - Fastest Available • Automatic Head Unloading - Protects Heats and Motor • 25 Sector Buffer • Progress System Throughput • High Rotational 28,000 Hz. MFR. No one else even close • 1.5 Watt Power Consumption - Lowest Available • 2 Year Warranty. Longest Available.



Seagate 30 MEGABYTE WINCHESTER HARD DISK KIT

\$495

\$459

U.S. Robotics 2400

\$189

The US Robotics Micro 2400 modem is one hundred percent Hayes compatible, auto dial, auto answer, auto everything, loud-speaker included. A super value at only \$189.



Smarteam 2400

\$259

The Smarteam 2400 offers all the features of the Hayes Smart Modem 2400 for a fraction of the price. Now is your opportunity to purchase a 2400 baud modem for only \$259.

Also available: The Smarteam 1200 at only \$119

Model	Price
Aviatex 1200 baud internal Hayes	99
Hayes Smartmodem 2400 baud modem	529
Smarteam 2400 Hayes Compatible	259
Team 1200 Hayes Compatible 300/1200	119
Smarteam 1200B IBM 1200 baud card	119
Ultralink 1200 data and voice, 8K 292	99
Prometheus 1200 super feature	289
Prometheus 1200B internal PC	199
Signatrim Mark VI, 300 baud internal PC	35



Five Inch Winchester Disk Drives

Model	Price	each	two +
SEAGATE 225 20 Meg. 1/2 Ht.	269	259	
SEAGATE 238 30 Meg. RLL	299	289	
SEAGATE 4026 26 M. 35mS.	559	539	
SEAGATE 4051 51 M. 35mS.	695	659	
SEAGATE 4096 96 M. 35mS.	959	829	
FUJITSU 2242 55 M. 35mS.	1399	1329	
FUJITSU 2243 85 M. 35mS.	1895	1819	
RODIME RO-202E 27 Meg.	495	479	
RODIME RO-203E 40 Meg.	695	659	
RODIME RO-204E 53 Meg.	995	959	
CONTROL DATA 94155-86 M.1829	1779		
MAXTOR XT1140 140 Meg.	2595	2529	
TOSHIBA MK5670 M.30mS.	1789	1729	

- Winchester Controllers for IBM/PC
 - XEBEC 1220 with floppy controller 229
 - OTC 5150CX 139
 - DMTI 5520 half card 129
 - DMTI 5527 RLL controller 159
 - ADAPTEC 2070 RLL controller 179
 - ADAPTEC 2010A 159
 - WESTERN DIGITAL WD/1002WX2 119
- SCSI/SASI Winchester Controllers
 - XEBEC 1410A 5 1/4" foot print 219
 - WESTERN DIGITAL 1002-05E 5 1/4" 289
 - DMTI 20L 119
- Winchester Accessories
 - Installation Kit with manual 10
 - Winchester enclosure and supply 139
 - Dual 20/34 cable set 25
 - Switching power supply 49

Shipping: First five pounds \$3.00, each additional pound \$.50
Foreign orders: 10% shipping, excess will be refunded.
California residents add 6 1/2% sales tax. • COD's discouraged.
Open accounts extended to state supported educational institutions and companies with a strong "Dun & Bradstreet" rating.

VISA

master charge

TeleFax (213) 217-1951

TOLL FREE ORDER LINE (800) 421-5041

TECHNICAL & CALIFORNIA (213) 217-0500

Own your own computer and office supply business!

I'm Jerry Saperstein, founder and President of DISK WORLD!, Inc. Since 1983, I've earned more than \$ 250,000 a year selling computer and office supplies.

And so can you.
Enter a major industry without major capital!

More than twenty-two billion dollars worth of office and computer supplies will be sold this year...most of it on a local level from small stores and independent agents.

Through mail order advertising, I can't capture the interest of most of the 20,000,000 businesses who need and buy office and computer supplies...but you can because you are local to them...and you can do it far more economically than I could through national advertising.

And that situation creates an opportunity for you.

A money making opportunity!

I'd like you to explore the possibilities of establishing your own part or full time computer and office supply business.

It can be operated easily out of your own home.

You'll be offering more than 25,000 commonly used office and computer supply items at substantial discounts from list price, easily offering better bargains than local suppliers...but still making a profit for yourself.

Let me show you how...

I've prepared a complete business plan called "Making Money In Office and Computer Supplies".

It shows you everything you need to know...including advice on how to avoid failure.

The business plan costs \$ 24.95...and you can read it for 10 days and return it for a full refund for any reason within that time.

Or you can get our FREE expanded information package.

The choice is yours.

I'd like to see you in the office and computer supply business because it would be good for both of us.

You would make some money...and so would I...and so would thousands of businesses who could save money on all their computer and office supply needs.

Take advantage of this offer today and order "Making Money In Office And Computer Supplies" WITHOUT RISK or ask for the FREE expanded information package.

Office & Computer Supplies, Inc.
P. O. Box 1415
Highland Park IL 60035

Office and Computer Supplies, Inc.
P. O. Box 1415
Highland Park IL 60035

Yes! Enclosed is my check or money order for \$ 24.95. Please send me a copy of "Making Money In Office And Computer Supplies". I understand that I may return it within 10 days for a full refund for any reason whatsoever.

Well, I'm not quite ready to buy the business plan yet, but please send me the FREE expanded information package.

Name: _____

Address: _____

City: _____ State: _____ ZIP: _____

Please PRINT or TYPE all information!



APPLIED MICRO TECHNOLOGY
IMPORTER - EXPORTER
P.O. BOX 24783, LOS ANGELES, CA 90024
800 458-0070 (NA)/213 474-0070 (CA)
TLX: 263220 AMT UR



MEGA
BERNOULLI TECHNOLOGY

20+20 \$1895
Single 20 \$1334
10+10 \$1569
Single 10 \$995
Tri-pac 10/20 199/250
Interface pc2/pc2B \$149/195

FREE
CARTRIDGE
PER
SYSTEM



All electronic components and computer parts. International orders welcome.

Inquiry 18



CROSS-16 META ASSEMBLER

- Table based 8/16 bit cross-assembler.
- Uses manufacturer's assembly mnemonics.
- Tables & Example Source files are included for ALL of the following processor families:

1802	3870	64180	6502
65816	6801	6805	6809
6811	68000	7000	8048
8051	8085	8086	8096
COP800	SUPER8	Z8	Z80

- Users may modify or create new tables for additional processors.
- Produces listing, symbol table, and 8/16 bit binary, Intel and Motorola hexcode.
- 5" DSDD for PC/MS-DOS 2.0 or greater.
\$99.95 US \$ 139.95 CDN
- Portable C sourcecode is available.

Worldwide shipping (AIRMAIL) & handling included. Credit Card orders (\$139.95 CDN) please specify: Card number, name on card and expiry date



Universal Cross-Assemblers
P.O. Box 384, Bedford, N.S.
Canada B4A 2X3

Inquiry 300

NEW!



SafeSkin™
KEYBOARD PROTECTOR

Remains in place during keyboard use. Prevents damage from liquid spills, dust, ashes, etc. Fits like a second skin, excellent feel. Available for: IBM-PC, AT, Apple (all), Compaq, Model 100, NEC 8201, C64, Zenith 150, DEC, Kaypro, KB5151, AT&T 6300, WYSE 50 and many others. Send \$29.95, check, M.O., Visa & MC include exp. date. Specify computer type. Dealer inquiries invited. Free brochure avail.

Merritt Computer Products, Inc.
4561 S. Westmoreland, Dallas, Texas 75237
(214) 339-0753

Inquiry 175



6805/6305 SINGLE CHIP MICROCOMPUTER DEVELOPMENT SYSTEMS

Two systems allow the IBM PC/XT/AT to be used as a complete development system for the MOTOROLA 6805 series single chip microcomputers. Model MCPM-1 supports the MC68705P3, P5, U3, U5, R3, & R5 chips. Model MCPM-2 supports the MC1468705F2 & G2 cmos versions. Both systems are priced at \$495 and include a cross assembler program, a Simulator/Debugger program and a programming circuit board with driver software. A system is also avail. for the HITACHI 63705 ZTAT micro.

THE ENGINEERS COLLABORATIVE
P.O. Box 53, West Glover, VT 05875
(802) 525-3458

Inquiry 90

DON'T BUY A BBS!

Until you've seen DLX

- Electronic mail
- XMODEM
- Multiple choice questions
- Essay questions
- Database query system
- User-to-user chatting
- Easily customized
- Up to 9 phone lines
- 2-line version: \$200

Requires IBM PC/XT/AT or clone, DOS 2.0 or later

Inner Loop Software
5456 McConnell Ave., Suite 120
Los Angeles, CA 90066
(213) 822-2800 (voice)

Inquiry 130

TEXT TO SPEECH



SMART SPEAKER \$229.95

The most advanced text to speech converter for your computer

- ★ Connect to ANY COMPUTER having parallel or RS 232 port
- ★ Will work with ANY SOFTWARE that can drive a printer
- ★ No additional slot or I/O required
- ★ Built in AB switch shares your printer port
- ★ Built in speaker + audio amplifier
- ★ Facility to connect external speaker
- ★ Can drive external amplifier, VCR, cassette, phone answering systems etc.
- ★ Optional 1200 Baud Modem with touch tone decoder and software for hooking up as order processing system...

SWISSCOMP inc
5312-56th Commerce Park, Tampa, FL 33610
Info: (813) 628 0906
Orders: (800) 888 0304 extension 45

Inquiry 282

FEDERAL
FREE WHEN YOU PAY
GROUND RATES!



S=100

"THE PC PEOPLE"

10th Anniversary Specials

PC COMPATIBLE SYSTEMS



AST
Premium
286™

AST PREMIUM/286 - Model 140 with 44 Mb 28mSEC Drive, 10MHz 80286 with 11.5 Norton, 1Mb 100nSEC RAM, Serial & Parallel Ports, Clock/Cal. RT-Style Keyboard, 3-G Plus Card with EGA-CGA-HGC and 256K RAM, and MS-DOS, GW-BASIC..... **\$65./mo.***

This ad produced on an AST Premium Publisher.
* 1 to 5 year leases available to qualified businesses.

WYSE

WYPC-286 10 MHz, 640K, S, P, 1.2 Floppy **\$1,488**
WYPC-286-85 w/72 Mb 20mSEC Hard Disk... **\$2,498**
WYPC-286-20 w/20 Mb Hard Disk..... **\$1,759**

INDTECH

5170 Basic System - 12 Slots, 80286, 512K, 238W P/S, WD-WA2 Controller, 1.2Mb Floppy Drive, Keyboard, MS-DOS 3.2 & GW-Basic, Manual & Set-Up. **Will Run Novell Non-Ded 286!!!**..... **\$1,195**

MONITORS & TERMINALS

AST WYSIWYG Full Page Monitor & Ctrl. **\$1,197**



SAMSUNG ONE YEAR WARRANTY AND 30 DAY D.O.A. SWAP-OUT!

Samsung EGA Tilt 'n' Swivel, 14" Monitor..... **\$365**
Samsung 14" Tilt 'n' Swivel Color Hi-Res..... **\$249**
Samsung 12" TTL Tilt 'n' Swivel Amber..... **\$ 79**

TATUNG

Tatung CM-1365 RGB 13" 5-Color Text Switch... **\$319**
Tatung CM-1380F EGA 13" 640x350 G/A Switch **\$429**
Tatung MM-1422 Dual Frequency 14" Grn/Amb. **\$125**
NEC Multisync Monitor..... **CALL**



WYSE 30..... **\$329**
WYSE 50..... **\$388**
WYSE 60..... **\$419**
WYSE WY700 1280 x 800..... **\$749**

POWER SYSTEMS & ACCESSORIES

CACO P-15 Monitor Base..... **\$ 75**
PowerSavers mfg by TOPAZ - Sine Wave UPS, 400, 800, 1000 Watt Models..... **FROM..... \$459**



10MHz

The ALL "NEW" EasyData™ SUPERturbo XT

"AT-Style" Case and Keyboard, 10 MHz 8088-1, 120nSEC RAM 640K, 150 Watt Power Supply 360K Floppy. All "FCC" Approved with one year parts and labor warranty..... **\$ 439.00**

MGP - Mono, Graphics, Printer Board... **\$ 48.00**
CGP - Color, Graphics, Printer Board... **\$ 59.00**
EGA with CGA, MDA..... **\$ 135.00**
Monitors..... **See Samsung**
Fujitsu 360K Grey Floppy..... **\$ 85.00**
20 Mb Seagate and Controller..... **\$ 295.00**
IOC - Floppy, S, P, Game, Clock Ctrl... **\$ 75.00**
MUL - 0-384K, S, P, Game, Clock..... **\$ 79.00**
RT-Style Keyboard..... **\$ 69.00**
New Word like WordStar 4.0 w/System **\$ 149.00**

Call for Free brochure on EasyData.

MODEMS

CTS 2424 ADH ASYNCH/SYNCH (Hayes)..... **\$248**
CTS 2424 AMH Class 4 MNP Error Correct..... **\$328**
CTS Half-Pak 24 1/2 Card w/Dyna-Mite..... **\$219**

EasyData™ Modems.

Hayes compatible and more!

EasyData 1200 PC Half Card with PC-Talk..... **\$ 88**
EasyData 2400 PC Full Card with PC-Talk..... **\$178**
EasyData 1200D - External..... **\$ 97**
EasyData 2400D - External..... **\$187**
MultiTech..... **CALL**
ProModem 1200B with Mirror Software..... **\$115**



6-PAK Premium/256K..... **\$159**
RAMPAGE-286-512K..... **\$378**
HotShot 286-10XT Accel. Board **\$369**
RAMvantage 128K-2 Mb..... **\$188**
ADVANTAGE-128K..... **\$325**
3G-PLUS 256K, HGC, CGA, EGA. **\$225**

Intel Above Board/286-512K 4020..... **\$349**

CONNECTIVITY

WE ARE ONE OF THE OLDEST AND MOST EXPERIENCED NETWORK DEALERS IN THE NATION!
CALL OUR EXPERT SALES & TECH STAFF WITH YOUR CONSULTATION AND INTEGRATION QUESTIONS.

WESTERN DIGITAL

StarLab/Novell Starter Kit - **\$1,095**
StarHub 10 Active Ports..... **\$ 329**
StarCard..... **\$ 165**
StarCard Plus - No DMA Needed... **\$ 198**
StarLink Card w/Active Hub..... **\$ 215**
EtherCard Plus..... **\$ 265**

LASER PRINTERS

OKIDATA LASERLINE 6
Ricoh Engine, 6 Pages per min.
128K RAM (expands to 512K)
Perfect for Text Intensive
Applications..... **\$1,488!**



H. P. LaserJet Plus Series 2..... **\$ 1,888**
Cordata LP-300 Laser Printer..... **\$ 1,649**

QMS - PS-800 Plus..... **CALL**
Texas Instruments..... **CALL**
XERCX 4045 Model 50-512K-1.5 Mb, Serial/Para. I/F, 10 Pgs/Min., Copier & 90 days on-site service... **\$ 3,595**
AST TurboLaser Ricoh Engine, 8 pages per min, 300x300 DPI, Fast Graphics..... **\$ 2,695**

PRINTERS & PLOTTERS

brother M-1709 \$425

FREE Freight in the U.S.

Xerox/Diablo 635 with Parallel Interface..... **\$749**
Panasonic..... **CALL**
Toshiba P351 Model 2..... **\$969**
houston instrument DMP 41/42..... **\$ 2,398**
DMP 51/52..... **\$ 3,499**
DMP 56A..... **\$ 4,399**



Ventura Ver. 1.1 **\$488**

NewWord - Like WordStar v4.0..... **ONLY..... \$159**

DRIVES



ID130 133Mb, 20mSEC with Installation Hardware/Software (XT-1140 Compatible)..... **\$ 2,195**
ID75 74Mb, 20mSEC..... **\$ 1,079**
ID100 103Mb, 20mSEC w/AT RLL Controller... **\$ 1,239**
ID230 233Mb, 20mSEC w/software & RLL Ctrl\$ **2,888**
V150 43Mb..... **\$699**
Everex 601 60Mb Internal Tape..... **\$759**
Irwin 20Mb Internal Tape..... **\$465**

MICROPOLIS

Micropolis 85Mb 28 mSEC..... **\$898**
Mitsubishi MF501 48TPI... **\$ 91 /MF504 96TPI... \$129**
Seagate 20 Mb PC Subsystem with ST-225 and Controller..... **\$ 279**
Seagate 30 Mb PC Subsystem w/ST-238 & Ctrl\$ **388**
Seagate ST-251 51Mb HH Hard Drive..... **\$525**
Teac FD-55-BV 48TPI Floppy Drive..... **\$ 89**
Fujitsu 360K Floppy Drive..... **\$ 85**

3-User Network Special — **\$127/Mo.***



Server/Work Station:

INDTECH 6/8 MHz 286, 12 slots, 238Watt P/S, Serial & Parallel Ports, Monitor, 1.2 Mb Flpy & 360K Flpy, 1 Mb RAM, 71 Mb @ 28mSEC H.D.

NOVELL Non-Dedicated NetWare 286

ArcNet 4-Port Passive Hub

3 ArcNet Cards and Cables upto 100 Feet Each.

2 EasyData SUPERturbo XT 640K, 10MHz, 8088-1, & "AT-Style" Keyboard, "FCC" Approved.
3-Amber Monitors Included.

**** A COMPLETE NETWORK ****

RETAIL..... **\$9,258** NOW ONLY..... **\$5,395**

*Leasing available to qualified businesses.

ArcNet Starter Kits with Novell Software

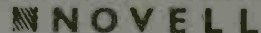

Complete Kit..... **\$1,949**

With Advanced NetWare 286 v2.0A

3 CompuPro PC ArcNet Cards and Cables

1 CompuPro 4-Port Passive Hub

EtherNet Kit with File Server Card, Two

Work Station Cards & NetWare 286... **\$2,095**

intercontinental Micro Systems - MS-CPS-PC PC/XT/
AT Slave CPU Card and Graphics Terminal with
Software to Install in Novell Environment..... **\$1,095**

ArcNet Compatible Fast Card..... **\$175**

ArcNet 8-Port Active Hub..... **\$395**

ArcNet 4-Port Active Hub PC/Card..... **\$195**

ArcNet 4-Port Passive Hub..... **\$ 35**

800-528-3138 Orders Only 602-991-7870 Customer Service

S-100 DIV./696 CORP. 14455 NORTH 79TH ST. SCOTTSDALE AZ 85260

TELEX 9103806778 SONEHUND FAX 602-483-0920

Advised prices are cash, prepaid, VISA or M/C Only! Customers qualifying for terms calculate addl charges in the following way. P.O.'s & AMEX + 95. C.O.D.'s + 99. Shipping first 6 lbs. min. \$5.00. *Free FedX only applies to orders from 1-9 lbs & over \$50. Sales tax AZ res. only. All returns subject to a restocking fee or full credit towards a future purchase. All prices subject to change without notice.

Inquiry 284 for End-Users. Inquiry 285 for DEALERS ONLY.

SEPTEMBER 1987 • B Y T E 355

DISK-KING®

COLOR DISK - 3M or BASF

WHY RISK THE UNKNOWN... when you can get premium quality disks from the Leader and Inventor of magnetic media... for less!!

- ★ 100% tested & certified at 65% or higher clipping level★
- ★ 10 mil sturdy jacket ★ LIFETIME WARRANTY ★

5.25" Diskettes: Color Disk 3M/BASF

DS-DD-48 TPI Bulk	.48	.54/.43
DS-DD-48 TPI Boxed	.55	.61/.50
DS-HD-96 TPI-Bulk	1.08	1.05
DS-HD-96 TPI-Boxed	1.15	1.12

3.5" Diskettes:

DS-135 TPI Bulk	1.49	1.20
DS-135 TPI Boxed	1.59	1.29

All 5.25" diskettes are supplied with Tyvek® sleeves, color-coded ID labels, w/p tabs. Color Disks In Rainbow Assortment.

DISK-COTECH® presents DISK-COTECHnicolor®

- Warranted Forever
- Exceeds ANSI Specs
- 100% tested & certified
- 14 color options
- Clipping level-75%
- Tyvek® & labels

DS-DD-48 TPI	5.25"	DS-HD-96 TPI
.69	COLOR BULK	1.59
.84	Plastic Library Box Color	1.74
3.25" DS/135 TPI, 12 Colors	Plastic Library Box	1.69

3M FREE SCOTCH!!!

DS-DD	"bonus product & rebate inside while supplies last.	DS-HD
.81	5.25"	1.65
1.63	3.50"	4.80

SS-DD-RH	3M's Highland Diskettes	DS-DD-RH
.49	5.25" 10/bx Tyvek, labels, w/p tabs	.50

DC-1000	12.75	DC-300XL/P	18.95
DC-2000	17.25	DC-600A	21.65
3M Headln Kit for 5.25"	6.99	for 3.5"	10.99
3M Mag. Tape 2400'			12.40
3M Mag. Tape 1200'			9.40
3M 8" DS-DD	2.06	3M 8" SS-DD	1.89

BASF *FREE! Color-Coded Modular Flexy Files a \$19.95 value!

5.25" DS-DD in *Minidex/6083
3.50" DS-DD in Microdex/25	...	1.49
5.25" DS-DD in Plastic Library81
3.50" DS/DD in Plastic Library Box/10	...	1.45

Nashua BULK DISKETTES 5.25" DS/DD

5.25" DS-DD	.53	100% Certified Error Free
5.25" DS-HD-AT	1.39	Exceeds ANSI Specs
5.25" DS-DD96TPI	1.29	Lifetime Warranty
3.50" DS-DD	1.39	USA Made for Tyvek® & labels

RIBBONS STORAGE

Epson MX/RX/FX70/80/85	2.89	3M Discover 50	7.95
Epson MX/RX/FX 100/185	3.75	3M D/Defender 07D w/key	14.95
Epson LQ1000	3.99	3M Data Defender 50	14.99
Epson LQ1500	3.99	SRW Minidex/60	9.95
Okidata Twin Spool	1.19	SRW Microdex/25	9.50
Okidata 182/192/193	3.45	Plastic Library Case	1.50
Apple Imagewriter	2.75	Micro Library Case	1.75
IBM Printer	3.99		
Brother HR 15/25 M/S	4.45	ACCESSORIES	500 1000
Panasonic KXP	4.99	Tyvek® envelopes	...055 039
NEC 3500 M/S	4.05	Color-Coded ID label	...035 019

TERMS: No surcharge on VISA, Mastercard or AMEX. COD add \$3.00. Prepaid deduct 2% cash discount. POs accepted from recognized institutions. Shipping: \$4/100 or fewer disks. Reduced shipping on larger quantities.

TELEX - 9102404712
1-800-523-9681 TOLL FREE 1-801-572-3589

DISK-COTECH DISKCO TECHNOLOGIES, INC.
P.O. Box 1339 Sandy, Utah 84092
356 B Y T E • SEPTEMBER 1987

IEEE488

Technology that hits the mark

- For IBM-PC/XT/AT/IC/RT6150 and all other compatible computers
- For PHILIPS PC :YES
- HP commands (enter, clear etc.) implemented
- SRQ/ASYST compatible
- 64 kByte memory capacity
- DMA and INTERRUPT can be activated by simple commands
- HELP functions, SYNTAX monitoring in clear text
- BASIC, BASIC(compiled), TURBO-BASIC, (TURBO-) PASCAL, MODULA-2, FORTRAN, C, ASSEMBLER

DEALER + OEM WELCOME



ines GmbH
Neuenhofer Allee 45
5000 Köln 41
West-Germany
Phone: +49-221-438659
Teletex: +2627-221-4237 glzkn
FAX: +49-221-491871

Inquiry 129

SPECIAL EPROM PROGRAMMER

APROTEK 1000 ONLY \$225.00

COMPLETE WITH PERSONALITY MODULE

117 AC POWER-RS-232 CONNECT - 8 BAUD RATES - HANDSHAKE TO HOST ALLOWS READ, WRITE, VERIFY & COPY

Comes complete with IBM-PC, Apple IIe, or CPM (Specify Computer) Driver Program on Disc.

Programs the following 5 Volt 24 or 28 pin devices: 2716 series through 27512, 25xx series, 68764 plus others. Please Specify Personality Module desired with order. Additional Personality Modules only \$15.00 ea. Full 1 year warranty.

TO ORDER: CALL 1-800/962-5800 OR WRITE APROTEK 1071 A AVENIDA ACASO Adkl CAMARILLO, CA 93010 \$4.00 Shipping USA Info (805) 987 2454 VISA or MC Add 3% We Accept Govt., School & Large Corp. P.O.s

Inquiry 19

COMPUTER RECEIPT CASH DRAWER/PRINTER

Single RS 232 interface controls both

M-S CASH DRAWER
10711 Flower St., Stanton, CA 90680
(800) 544-1749
In California Call:
(714) 821-1133

Inquiry 191

6809 Single Board Computer

6809 MPU, 2 serial ports, 4 parallel ports, RAM, EPROM, real-time clock, watchdog timer, 44-pin 4.5" x 6.5" PCB

EXPANSION MODULES: RAM, EPROM, CMOS RAM/battery, analog I/O, serial I/O, parallel I/O, counter/timer, IEEE-488, EPROM programmer, floppy disks, cassette, breadboard/display.

Wintek Corp.
4801 South Street
Lafayette, IN 47904
317-742-6428

Inquiry 315

DATA ACQUISITION TO GO INTERFACE FOR ANY COMPUTER

FREE IBM SOFTWARE

Connects via RS-232. Fully IBM compatible. Built-in BASIC. Stand alone capability. Expandable. Battery Option. Basic system: 16 ch. 12 bit A/D, 2 ch. D/A, 32 bit Digital I/O. Expansion boards available. Direct Bus units for many computers.

(201) 299-1615
P.O. Box 246, Morris Plains, NJ 07950

ELEXOR

Inquiry 88

NOW, AN EASY WAY TO SHARE YOUR PRINTER!

Share any number of PC's and printers without cables, switches, or waiting. Just plug PAMCO's Lil' Devil into the printer port of your PC. Works like a printer buffer and saves the data on a removable RAM cartridge. At your convenience, plug the RAM cartridge into another Lil' Devil attached to your shared printer. Easy!

Allows you to work anywhere. Frees your PC and Printer. Even a floppy disk can't do all that PAMCO's Lil' Devil can.

Comes complete with power supply, standard parallel printer port receptacle, standard parallel printer cable and plug, one RAM cartridge and instructions for only \$149.95.

Call for more information 1-800-255-6265
N.C. 704/529-1593
PAMCO 920 Blairhill Rd., Suite 101
Charlotte, NC 28217

Inquiry 213

ACP's Software Sale!

ASHTON TATE dBase III Plus 1.1 Framework II 1.1 Multimate Advantage II	CALL CALL CALL
BORLAND Turbo Tutor 2.0 Turbo database Toolbox 1.2 Turbo Lightning 1.0 Turbo BASIC 1.0 Sidekick 1.5 Eureka 1.0 Turbo C 1.0 Reflex 1.1 Superkey 1.1	\$25.00 41.00 58.00 58.00 50.00 59.00 59.00 86.00 59.00
BRODERBUND Graphics Library 1 Graphics Library 2 Print Shop	\$23.00 23.00 34.00
CROSSTALK COMM. Crosstalk XIV.v 3.61	\$95.00

DAC DAC Easy Payroll DAC Easy Accounting	\$33.00 45.00
GENERIC Generic CADD 3.0	\$68.00
JAVELIN Javelin 1.1	\$138.00
MICROPRO Wordstar Professional Rel. 4 Wordstar 2000 Plus Rel. 2	\$257.00 288.00
MICRORIM Rbase Graphics 1.0 Rbase System V 1.1	\$160.00 415.00
MICROSOFT Window 1.03 Multiplan 3.02 Project 3.01 Word Quick BASIC 2.01	\$64.00 122.00 240.00 225.00 62.00

MIGENT Ability Plus	SALE
MONOGRAM Dollars & Sense	\$110.00
QUARTERDECK Desqview 2.0	\$63.00
SOFTWARE PUBLISHING Harvard Prof. Publisher First Choice 1.0	\$405.00 109.00
SYMANTEC Q & A 2.0	\$219.00
WORDPERFECT Wordperfect 4.2 Library 1.1	\$245.00 65.00

EGA SPECIALS
• EGA Monitor plus EGA Card
• NEC Multisync plus EGA Card
**\$519.
\$719.**



VALUES SINCE 1976!

SHOWN WITH OPTIONAL MONITOR AND SECOND DISK DRIVE
\$899.
...retail value over \$2995!
GUARANTEED!

SHARP "AT" Model 7501K...
(Made by the same Mfg. as Epson Equity III)
• 80286 6/8 Mhz Switchable
• 512K RAM Expandable to 640K
• Hard Disk Controller • 84 key AT Keyboard
• 1.2Mb Floppy w/Controller 8 1/2 Slots
• Serial and Parallel Ports
• MS-DOS 3.1 & GW Basic included FREE
PLUS SPECIAL OFFER...
AST "ADVANTAGE AT" ... List \$1745.00
w/3Mb **ONLY \$469.00**

That's right... get a 3Mb factory populated AST Advantage card plus serial/parallel I/O, tested! — With purchase **ONLY \$469**

PLUS...
FREE Software including SIDEKICK*, DESQVIEW* and SUPERPAK*
FACTORY WARRANTY INCLUDED



SALE!
SHOWN WITH OPTIONAL MONITOR
SUPER VALUE!
\$499.
Advanced PC/XT
... over 4000 Satisfied Customers!

Manufactured by Toshiba. This is the finest IBM compatible manufactured today... we can prove it!
• FCC/UP Approved
• Serial/Parallel/LCD
• Mouse & Keyboard
• 256K easily Expandable to 640K
• 10Mb Hard Disk/Add \$275
• (1) 360K Floppy
• Composite Video
• RGB Color Graphics
• 20Mb/Add \$350



BARE BONES! PRICE!!!
\$299.
Advanced
8 Mhz XT Turbo
• 4.77/8MHz Switchable
• Zinc-lined FCC Case
• OK, expandable to 640K
• 150W Power Supply
• XT/AT Deluxe Keyboard
• Phoenix BIOS
• Runs all Major software written for IBM
90 DAY WARRANTY

IBM COMPATIBLE CARDS

AM200 "Diamond-Pak" (HGA, FD, (2)S, P, C, G) All-In-One	\$139.95
AM210 Color/Printer/CGA	69.95
AM230 CGA/TTL/Printer/132 Col.	79.95
AM240A Mono/Printer/Herc. (1/1/2)	69.95
AM250 Mono/Printer/132 Col.	69.95
AM271 EGA w/256K RAM (1/2)	169.95
AM273 EGA (Genoa Comp.) (1/2)	189.00
AD340 MIO w/Floppy	69.95
AD410 (2) Floppy I/O w/cables	29.95
AC340 Game Card PC/XT/AT	39.95
AC511 Parallel Port PC/XT/AT	39.95
AC530 Serial Port PC/XT/AT	49.95
AR319 OK Multi-function (6 Pk.)	69.95
AM640 Floppy-Hard Controller/AT	189.95
AS956 XT Turbo Motherboard/OK	99.95
AS949 AT Turbo Motherboard/OK	379.95
AS951 Baby AT Motherboard/OK	379.95
1200 Hayes Modem (int. or ext.)	79.98
2400 Ha. Modem (int. or ext.)	239.00

ACCESSORIES

NC100 256K Printer Buffer (par.)	\$149.95
NC101 Parallel to Serial Converter	89.95
NC102 Serial to Parallel Converter	89.95
NC205 Switch Box 3636-AB	34.95
NC201 Switch Box 2525-AB	34.95
Buffalo SX Multi-Connection	499.95

HARDWARE SPECIALS!!!

AST - 2 Yr. Warranty	
Advantage AT w/1.5Mb	SALE \$389.95
Advantage AT w/3.0Mb	SALE 499.95
Rampage AT w/512K	SALE 269.95
Preview I/O XT/AT	189.95
AST MP II 64K exp. to 384K w/cik	98.95
AST Mini Pak 1/2 card w/384K	99.95
Combo Plus w/OK ser. par. clock	69.95
Sixpack Premium w/256K	299.95
Advantage Premium 512K	CALL
Knight Security Software (Sixpack)	99.95
AST Turbo Laser	3995.00
AST Premium 286 Model 170	CALL

EVEREX

Evercom II 1200 Baud Modem (int.)	\$119.00
Evercom II 2400 Baud Modem (int.)	198.00

HAYES (2 Yr. Warranty)

1200 RS-232 External	\$366.00
1200B w/SMARTCOM (int.)	344.00
2400 RS-232 External	569.00
2400 w/SMARTCOM II (int.)	499.00

HERCULES

Hercules Incolor Card	CALL
Hercules Plus Graphics	188.00

INTEL (5 Yr. Warranty)

Above Board AT/128K	\$349.00
Above Board 286/512K	435.00
Inboard 386/AT	1488.00
8087 Coprocessor	105.00
8087-2	145.00
80287-6	165.00
80287-8	260.00
80287-10	449.00

KEYTRONICS

5151 Deluxe Keyboard	\$189.95
5153 Deluxe Keyboard w/pad	285.95
ACP 5150 Keyboard	58.95
ACP 5151 Deluxe Keyboard	79.95
ACP 5160 AT/XT Keyboard	66.95
ACP 5152 XT/AT Keyboard	79.95

MEMORY

64K/150ns	\$1.19
64K/120ns	1.49
256K/150ns	3.29
256K/120ns	3.49
256K/100ns	4.99
1Mb Chip 100ns Ea. 33.95	

BERNOULLI BLOWOUT

Dual 20Mb top of the line (refurb)	Retail \$3540
\$1499	

MIGENT (1 Yr. Warranty)

Pocket Modem 1200B w/software	\$159.00
-------------------------------	----------

MOUSE SYSTEMS (3 Yr. Warranty)

PC Mouse w/Pop-ups	\$99.00
Torrington Mouse	\$89.00

NEC (2 Yr. Warranty)

Multisync EGA Monitor	\$589.00
GB-1 Adapter Card (640 x 480)	365.00
Multispeed Laptop Computer	CALL

ORCHID (2 Yr. Warranty)

Turbo EGA	CALL
Tiny Turbo 286	439.00
PC Turbo 286E/1Mb	788.00
Jet 386 PC to 386	866.00

QUADRAM

Silver Quadboard PC/XT	\$129.95
Liberty PC/XT OK	169.00
Liberty 2Mb	408.00
Quadprint PC/XT Accelerator	166.00
Quad EMS I/O • 256K	339.00

PRINTERS

BROTHER

M2024L (24 Pin)	CALL \$699.00
M1109 100 cps	239.00
M1409 45 cps NLO	359.00
M1509 45 cps NLO	489.00
M1709 50 cps NLO	589.00

EPSON

LX-800 New! (80 col. 180 cps. 9 pin)	\$199.
EX-800 (80 col. 300 cps.)	\$407.00
EX-1000 (136 col. 300 cps. 9 pin)	535.00
FX-286e (136 col. 200 cps. 9 pin)	475.00
FX-86e (80 col. 200 cps. 9 pin)	345.00
LO-800 (80 col. 180 cps. 24 pin)	495.00
LO-1000 (136 col. 180 cps. 24 pin)	599.00
GO-3500 Laser Printer	1488.00
LO-2500 (136 col. 400 cps. 24 pin)	988.00

TOSHIBA

P321SL 24 Pin LO Printer	\$499.00
P341SL 24 Pin/216 cps	659.00
P351-C Color	999.00
T1000	CALL
T1100 & T3100	CALL

MONITORS

Princeton MAX-12 TTL	179.00
Samsung TTL IBM Green/Amber	88.00
TECO CGA Monitor	299.00
TECO EGA Monitor	399.00

AMDEK (2 Yr. Warranty)

Video 410A TTL/Amber	\$166.00
Color 722 EGA Color Monitor	488.00

TAXAN

760 EGA Monitor 14"	CALL
660 EGA Monitor 12"	CALL
560 EGA Card w/Autoswitch	CALL

3-1/2" DRIVES HARD DISKS

20Mb 3-1/2" LaPine LT200	\$299.00
30Mb 3-1/2" LaPine LT300	359.00

ALPHAMICRO

AlphaMicro VCR Backup Card	\$399.00
----------------------------	----------

FLOPPY DISK DRIVES

ACP IBM Drives DS	\$ 69.00
Toshiba FDD4403 3-1/2" w/Klt	129.00
Toshiba ND04D PC/XT 360K	95.00
Toshiba ND04E-G AT 360K	105.00
Toshiba ND08DE-G 1.2Mb	129.00
TEAC FD-55B	99.00

DISKETTES (BOX OF 10)

DS/DD for PC/XT (40tpi)	\$ 6.00
• ACP Generic	14.95
• Verbatim Datalife	14.95
• Maxell MD-2	14.95
• Fuji	14.95
DX/Hi-Density for AT (96tpi)	
• Verbatim	26.95
• Maxell	26.95
• Fuji	26.95
SS/DD for Apple II/etc.	
• Verbatim/Maxell/Fuji	9.95
Macintosh/IBM Conv. 3-1/2"	
• Maxell MI-2DD	26.95
• Fuji MF-2DD (135tpi)	26.95

MORE ACCESSORIES

Flip-Soft (holds up to 75 disks)	14.00
ACP 5-1/4" Disk Holder	9.00
ACP 3-1/2" Disk Holder	12.00
Head Cleaner 5-1/4" or 8"	9.00
PERFECT COMPUTER CARE Kit	19.95

CLOSEOUTS! SUPPLY LIMITED!

Epson Equity I	\$599.00
SHARP PC5000 Laptop	199.00
3M DC100A Data Cartridge	12.85
3M DC300A Data Cartridge	14.85
Quadboard II w/ 64K	89.95
Orchid PC NET Blossom w/ 64K	195.00
Q & A IBM Software/New Vers.	219.00
Epson Equity II	899.00
Bare Bones XT Fliptop	199.00
Persyst SB-III Multi-I/O	119.00
Persyst EG-8 EGA Card	99.00
Persyst Mono or Color Combo	99.95

★ Advanced Computer Products Inc.

TOLL FREE
800-854-8230
CA Residents 714-558-8813

OUR POLICY Inquiry 5
•No Surcharge for VISA or Mastercard.
•Volume purchasing agreements available.
•Orders subject to availability. •Supply limited on certain items.
•Pricing subject to change without notice.
•ACP Retail Store pricing may vary. Not responsible for typos.

Mail Order: P.O. Box 17329 Irvine, CA 92713
Retail: 1310 B E. Edinger, Santa Ana, CA 92705

CORPORATE BUYERS - CALL
CON, GILLES, PHIL, MIKE or DAVE

MAXELL

100% CERTIFIED
BULK DISKS

5 1/4" DS/DD **64¢**

5 1/4" DS/HD **1.64**

Price based on quantity of 300
Includes sleeves, labels and tabs.

SATISFACTION GUARANTEED

800-222-0490

In NJ 201-462-7628

• 24 Hour Shipment •

MEGAsoft

P.O. Box 710, Freehold, NJ 07728
Full service duplication facility

Inquiry 173

DATAFLEX™

- Multi-user Database!
 - Powerful!
 - Multiple Operating System Compatibility!
 - Attractive Dealer Pricing!
 - Full Dealer Support!
- Dataflex is a trademark of Data Access
Dealer Inquiries Invited

COGITATE

24000 Telegraph Road
Southfield, Michigan 48034 USA
(313) 352-2345

Inquiry 50



Sure it's insured?

SAFWARE® Insurance provides full replacement of hardware, media and purchased software. As little as \$39/yr. covers:

- Fire • Theft • Power Surges
- Earthquake • Water Damage • Auto Accident

For information or immediate coverage call:
1-800-848-3469

In Ohio call 1-614-262-0559

SAFWARE

SAFWARE. The Insurance Agency Inc.

Inquiry 254

WHY WAIT?

Run QNX now and do it all...
true networking, multi-tasking,
and multi-user systems.

SEE **QUANTUM** AD IN THIS ISSUE
QNX™ TOP RATED
NETWORKING
SYSTEM

We are QNX users and sell only QNX and QNX compatible products including wide area networking, nodes and bridges.

Call about our complete line of passive and active hubs.
Call or write for our catalogue.

T & T COMPUTER PRODUCTS

P.O. Box 33213 Tulsa, Oklahoma 74153
(918) 663-1879 MC/VISA Accepted
QNX is a registered trademark of Quantum

Inquiry 299

MOTION CONTROL DREAM

\$75 per axis

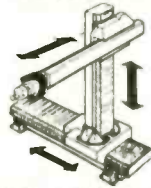

4 AXIS VERY SMART STEPPER CONTROLLER

- 49 high level commands in plain English.
- Macros. Battery backup for memory.
- Learn mode with optional "Teach Pendant"
- 4 axis simultaneous control. You select the ramps units, speeds, drive types...
- Input for Limit Switches, Panic button, etc.
- On board multitasking compiler.
- Works with any computer with a Centronics port or with the Alpha Products A-BUS system

See page 351 for details of the SC-149

ALPHA Products

Inquiry 10

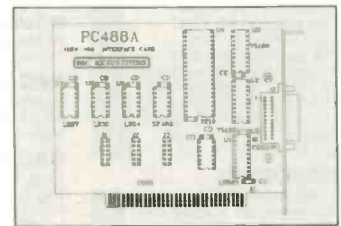

PC488

\$195

**LOW COST PC/XT/AT INTERFACE
FOR IEEE-488 (GPIB/HPIB)**

- SHORT CARD FOR PC/AT/XT & COMPATIBLES
- 1 OF 6 INTERRUPT LEVELS
- 1 OF 2 DMA CHANNELS
- UP TO 4 BOARDS / COMPUTER CONTROLLER / TALKER / LISTENER
- QUANTITY DISCOUNTS
- COMPATIBLE WITH MOST SOFTWARE PACKAGES

B & C MICROSYSTEMS

355 West Olive Ave, Sunnyvale, CA 94086
Phone (408) 730-5511 Visa & MC

Inquiry 37

"D" SIZE PLOTTER

\$1495⁰⁰



\$2295⁰⁰
RETAIL

Model PC 34/36
Pen Plotter:

(415) 490-8380

ZERICON

655 John Muir Drive • Suite 416
San Francisco, CA 94132

NEWS RELEASE

Inquiry 321

16-BIT RESOLUTION ANALOG-TO-DIGITAL CONVERTER

**12,000 SAMPLES/SEC
for IBM PC, XT & AT
SINGLE PIECE PRICE
\$475**

We manufacture a broad line of data acquisition and control hardware and software for Apple and IBM computers.

Call for quotes on custom hardware or complete systems.

LAWSON LABS, INC.

5700 RAIBE ROAD
COLUMBIA FALLS, MT 59912
406-387-5355

Inquiry 151

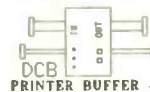

! not only a
printer buffer !

THIS IS THE MOST SOPHISTICATED
PRINTER BUFFER - MULTIPLEXOR - SWITCH

WITH TWO SEPARATE INPUTS (SERIAL AND PARALLEL) AND TWO SEPARATE OUTPUTS (SERIAL AND PARALLEL) CAN BE USED LIKE STANDARD BUFFER WITH ANY INPUT TO ANY OUTPUT BUT ALSO YOU CAN CONNECT 2 COMPUTERS TO 1 PRINTER OR 1 COMPUTER TO 2 PRINTERS OR 2 COMPUTERS AND 2 PRINTERS... AND MORE... 1 COMPUTER TO 3 PRINTERS OR 3 COMPUTERS TO 1 PRINTER
HIGH CAPACITY - 64 KB TO 256 KB AND - 256 KB TO 1 MB (MODELS A AND B) PAUSE COPY AND RESET FUNCTIONS SERIAL PORTS WITH 7 OR 8 BITS WORD LENGTH, 1 OR 2 STOP BIT, PARITY, XON/XOFF, DTR, RTS

DCB-A-64K \$ 195 DCB-B-256K \$ 255 (**)

(**) Power supply and parallel cables are included

ALSO, WE HAVE THE MOST COMPLETE DATA CONVERTER UNIT CONVERTS RS232 SERIAL TO CENTRONICS PARALLEL OR VICE VERSA, JUST BY MOVING JUMPERS BAUD RATE AND PROTOCOL FULLY PROGRAMMABLE FROM 150 TO 19200 BAUDS INCLUDES DTR, RTS, XON/XOFF, PARITY, etc

DCU \$ 80 (**)

(**) Power supply and cables NOT included



serial < > parallel
bi-directional converter



INTECTRA Inc. - Dept 272

2520 TERMINAL BLVD

MOUNTAIN VIEW - CA 94043

(415) 967-8818 TX 345545

Inquiry 131



Computer Valley

800-225-8216 (orders only) 408-739-3400 (CA res. & info.)
 1290 Oakmead Parkway, Suite 111 • Sunnyvale, CA 94086
 New England
 617-664-6994 • 1-800-648-7411 212 Main Street N. Reading, MA 01864

80386 PERSONAL COMPUTER

IDEAL FOR CAD/CAE/CAM/CAT WORKSTATIONS

- 2MB Memory Expandable to 16MB
- 2 Serial Parallel Ports
- On Board Socket for 80287
- 101 Keys Enhanced Keyboard
- FORTRON® 230 Watt Power Supply UL Listed
- 5 Drives Capacity Heavy Duty Cabinet
- 1.2MB TEAC Floppy Drive
- Western Digital Controller
- DOS 3.2 / GW Basic
- One Year Warranty

Intel iSBC
386 Compatible

Made in U.S.A.



\$2,590

2MB 32 BIT WIDE DATA BUS Memory Exp. Board (for Intel iSBC & compatible 80386 system)



\$590 each
w/2MB On Board

PACT-286-8 \$995

- 8 MHz ZERO WAIT STATE
- IBM AT Compatible • 6/8 mhz 0 Wait State, Norton S/I 9.2
 - 512K Installed, Expandable to 1MB On Board Memory
 - 1.2MB Floppy Drive • Floppy and Hard Disk Drives Controller
 - 230 Watt (max.) UL Listed Power Supply • DOS 3.2 GW Basic
 - Clock/Calendar with Battery Back Up
 - Optional: 2 Serial and 1 Parallel Port • Math Co-Processor 80287-8
 - 5 Half-Height Drives Capacity Chassis
 - One Year Warranty

PACT-286-10 \$995

10 MHz ONE WAIT STATE*

PACT-286-12 \$1,195

6/12 MHz DUAL CLOCK SPEED*

Same configuration as PACT-286 with 640K memory installed.

- Prices subject to change without notice.
- Intel iSBC is a trademark of Intel Corporation.
- IBM XT, AT is a trademark of International Business Machines.

TERMS:

- Shipping and handling charge starting from minimum \$6.00 each shipment.
- 15% restocking charge is required for nonauthorized return merchandise.

VIDEO BOARD

MGP \$69 Monographics adapter with printer port	EGA \$149 IBM® EGA, CGA, MDA compatible	SUPER EGA \$219 132 Column • Alphanumeric IBM® EGA, CGA, MDA comp. Super hi-res. 640x480 640x350, 720x348
TAPE BACK UP 20MB Internal \$459 20MB External \$559 60MB Internal \$550 60MB External \$650	DISK DRIVES TEAC 360K Floppy \$ 85 TEAC 1.2MB Floppy \$109 TEAC 40MB H.D.D. \$675 Chino 1.2MB Floppy \$ 99 Seagate ST-225 Kit \$299 Seagate ST-4038 Kit \$625 Seagate ST-4051 Kit \$725	MATH CO-PROCESSOR 8087 (5 MHz) \$105 8087-2 (8 MHz) \$152 80287-6 (6 MHz) \$174 80287-8 (8 MHz) \$245 80287-10 (10 MHz) \$300 80387-16 (16 MHz) \$590
KEYBOARDS MAXI SWITCH Enhanced 101 Key \$75.00 XT/AT 84 Key \$65	PANASONIC PRINTER CX-P108H 120cps NLQ \$195 CX-1091H 180cps / 32cps NLQ \$245 CX-1092 180cps / 32cps NLQ \$285 CX-1592 180cps / 38cps NLQ \$409 CX-1595 240cps / 51cps NLQ \$530 CX-P313 17cps Dotsybevel \$245 CX-P315H 22cps LQ Parallel Printer \$382	POWER SUPPLY DIRECT REPLACEMENT IBM XT, AT 200W AT Power Supply \$139 150 W XT Power Supply \$ 89

WHOLESALE PRICE TO PUBLIC!

10 MHz TURBO XT COMPUTER



- 640K RAM On Board
- 2 360K Floppy Disk Drives
- Disk Controller
- 150W Power Supply - 110/220V
- Full Function 'AT' Keyboard
- 8 IBM I/O Slots
- 8088-2 Micro Processor
- Front Panel w/LED and Keylock
- 10MHz/4.77MHz Clock Selectable

Fully Assembled & Tested
 1 Year Parts & Labor Warranty **\$49900**

PINECOM 'AT' 286 COMPUTER



13
MHZ
SPEED
TEST*

- 6/10MHz Clock Selectable
- 80286-10 CPU, 0 Wait State
- 220W Power Supply
- 1.2Mb Floppy Disk Drive
- Hard Disk/Floppy Disk Controller
- 512K RAM On Board (Exp to 1Mb)
- Clock Calendar w/Battery Backup
- AT Style Keyboard

Fully Assembled & Tested
 1 Year Parts & Labor Warranty **\$89900**

*The Land Mark Speed Test, Landmark Software Inc.



pinecom™

SPECIAL SALE PRICES

- SEAGATE ST-225 20Mb Hard Drive w/W.D. Controller \$299.00
- SEAGATE ST-238 30Mb Hard Drive w/RLL Controller 359.00
- SEAGATE ST-4038 30Mb Hi-Speed Hard Disk for AT 515.00
- SEAGATE ST-251 40Mb Hi-Speed Hard Disk - Half Height 440.00
- FUJI 30Mb Hard Drive 3.5" Light Weight w/Mounting 290.00
- Monochrome Graphic Card (Hi-Speed) w/Printer Port .. 65.00
- RGB Color Graphic Card w/Printer Port 65.00
- EGA Color Graphic Card w/256K RAM/Printer Port 160.00
- ATI EGA Wonder Card 220.00
- SAMSUNG TT_ Mono Amber 12" Monitor - 12SS 80.00
- SAMSUNG TT_ Mono Amber 12" Flat Screen Monitor 95.00
- MISUBA 14" Flat Screen Mono Monitor w/Base 120.00
- SAMSUNG 14" RGB Color Monitor - CD-1464W 250.00
- SAMSUNG 14" EGA Color Monitor 360.00
- TAXAN 12" EGA Color Monitor (640x400) - TX-660 380.00
- NEC Multisync EGA 14" Hi-Res Color Monitor 550.00
- Copy II PC Option Board (Copies all prot. software) ... 85.00
- LOGITECH C7+ Mouse w/Software (3 Buttons) 79.00
- 4 Serial Ports Card for AT (Com 1 to Com 8) 125.00
- 4 Serial Ports Card for XT (Com 1 to Com 8) 85.00
- EPSCN Printe FX-86E 240cps Dot Matrix 80 Col. NLQ 360.00
- EPSCN Printe FX-286E 240cps Dot Mat 132 Col. NLQ 495.00
- EPSCN Printe LQ-1000 180cps 24 Pin NLQ 132 Col. 670.00
- OKIDATA Printer ML182 120cps 80 Col Dot Mat NLQ 245.00
- OKIDATA Printer ML192 200cps 80 Col. Dot Mat NLQ 366.00
- OKIDATA Printer ML193 200cps 132 Col Dot Mat NLQ 529.00
- CITIZEN Printer 120D 120cps 80 Col. Dot Matrix NLQ .. 185.00
- Internal Modem 300/1200 Baud w/LED Panel (Misuba) 85.00
- External Modem 300/1200 Baud w/LED Panel (Misuba) 95.00

★ NEW ITEM ★ MINI VIDEO/AUDIO TRANSMITTER



Transmits Video/Audio signal from your computer, VCR or camera to a TV set (Ch 15 UHF) as far as 150 feet away. You can watch the same video tape from different TV set in different room or use your TV set as a remote monitor for your computer. AC adaptor included.

Only **\$4995**

PINE COMPUTER INC.

9690 TELSTAR AVENUE, EL MONTE, CA 91731
 STORE HOURS: MON - SAT 9:00 AM - 6:00 PM

PHONE ORDERS WELCOME: **(818) 575-1882**



TERMS: VISA or Mastercard accepted. COD order on Cashiers Check only. Check shipping charges when ordering. 3% surcharge for all credit card purchases.

Inquiry 232
 TELEX: 5106017376 PINECOM

Re-ink ANY FABRIC RIBBON automatically for LESS THAN 5 CENTS with



MAC INKER™

Over 11,000 cartridges and spools supported!

- MAC INKER IMAGEWRITER I AND II \$42.00
- UNIVERSAL (cartridge or spool) \$68.50
- MULTICOLOR IMAGEWRITER \$80.00
- MULTICOLOR ADAPTER ONLY \$40.00

Shipping (first unit) \$3.00

■ Lubricated DM INK EXTENDS PRINT-HEAD LIFE! Black, blue, brown, red, green, yellow, purple, orange—2 oz. bottle \$3.00; pint \$18.50. Gold, silver, indelible and OCR inks available. Heat transfer MacInkers and ink available plus a complete range of accessories for special applications.

■ Top quality, GUARANTEED, double density ribbon cartridges and reloads available.

■ DEDICATED MAC INKERS AVAILABLE FOR EXTRA LARGE OR SPECIAL CARTRIDGES.

**A BUFFER AND A DATA SWITCH!
PROTEUS™**

The "Siamese" Buffer



- 64K—\$199.00
- 256K—\$299.00
- Cable—\$10.00
- Shipping \$4.00

■ Proteus directs two printers working simultaneously, and frees your computer for other applications.

■ Now you can merge a form letter with your mailing list, set up one printer with letterhead, the other with envelopes, press "START" and RELAX while

PROTEUS DOES IT ALL—ALL AT ONCE!

■ Compact ■ 2 parallel ports ■ Multiple copy capability ■ "Flexible Capacity" buffer for each port.

1986 "Best Buy of the Year" Award!—Computer Shopper

PRINTER SHARING IN THE PC ENVIRONMENT!

KEYDEX™
"The Solution"



Priced
\$139.00—\$360.00

Shipping \$6.00

UG403 shown

- 4 PC's share up to two printers.
- Manual or automatic printer selection.
- Multiple copy capability.

All Keydex products are designed to "PLUG IN AND PRINT." There are no special drivers to add to your system and no complex routines to learn, so little time is lost while users adapt to the new system.

MERCURY MODEM

*100% Hayes™ compatible!



\$149.00

Shipping \$4.00

- 24 month warranty ■ Status lights ■ Speaker
- 300/1200 baud ■ Call progress detection.

Quick Link Communications software:
MS DOS and Macintosh—\$29.95
with modem—\$15.00 cable—\$15.00

*Hayes is a trademark of Hayes Microproducts.

DATA SWITCHES

- 2 Port—\$46.00
- 4 Port—\$59.00
- Shipping \$4.00

Parallel, serial, 2 or 4 way, crossed, etc.

CABLES: We carry cables for all common computers and peripherals. Rapid turn-around on custom orders. Competitively priced.

ORDER TOLL-FREE

1-800-547-3303

In Oregon (503) 626-2291 (24 hour line)

We are and always will be

Computer Friends®

14250 N.W. Science Park Drive
Portland, OR 97229, Telex 4949559
Dealer Inquiries Welcome.

	1985	1986	1987
Jan.	\$4.25		\$4.25
Feb.	\$4.25	\$4.25	\$4.25
March	\$4.25	\$4.25	\$4.25
April	\$4.25		\$4.25
May	\$4.25		\$4.25
June	\$4.25	\$4.25	\$4.25
July		\$4.25	\$4.25
Aug.	\$4.25	\$4.25	\$4.25
Sept.	\$4.25	\$4.25	
Oct.	\$4.25	\$4.25	
Nov.	\$4.25		
Dec.	\$4.25	\$4.25	

BACK ISSUES FOR SALE

SPECIAL ISSUES and INDEX

BYTE '83-'84 INDEX	\$1.75
BYTE 1985 INDEX	\$2.00
1984 SPECIAL GUIDE TO IBM PCs (VOL. 9, No. 9)	\$4.75
1985 INSIDE THE IBM PCs (VOL. 10, No. 11)	\$4.75

Circle and send requests with payments to:

BYTE Back Issues
P.O. Box 328
Hancock, NH 03449

Check enclosed *Payments from foreign countries must be made in US funds payable at a US bank.*

VISA MasterCard

CARD # _____ EXP. DATE _____

SIGNATURE _____

The above prices include postage in the US. Please add \$.50 per copy for Canada and Mexico; and \$2.00 per copy to foreign countries (surface delivery). Please allow 4 weeks for domestic delivery and 12 weeks for foreign delivery.

NAME _____

ADDRESS _____

CITY _____ STATE _____ ZIP _____

**BEST SELECTION
OF SOFTWARE TOOLS.**

Solving your scientific and engineering problems just got simpler.

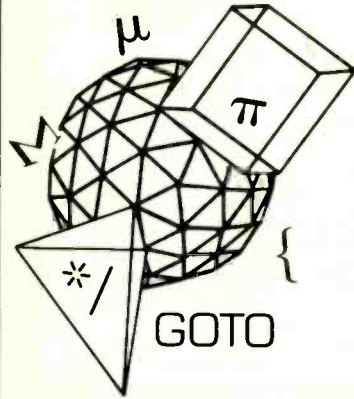

Science & Engineering Software Co. is the only source with all the software you need to solve your specialized problems: Statistical data analysis, circuit design, data acquisition and signal analysis, solving complex equations, 3D CAD/CAM design, high-tech graphics, technical word processing and more. Whether you're writing your own program or looking for a specific application, our experts can help you choose the best programs for your needs.

Call today and get our solutions working for you.

- No one offers you more variety.
- If you don't see a title, we'll special order it.
- If you don't know the publisher, we'll find it.
- Over 300 programs available.
- We offer a 30-day, money-back guarantee.*

CIRCUIT DESIGN

ECA-2	Tatum Labs	\$ 629
HiWire	Wintek Corp.	849
MICRO-CAP II	Spectrum Software	759
PADS PCB CAD Software		925
w/PADS-Route		1,639
smARTWORK	Wintek Corp.	849
TangoPCB	ACCEL Tech.	495
Tango Route	ACCEL Tech.	495

DATA ACQUISITION/SIGNAL ANALYSIS

Asyst 2.0	Macmillan Software	\$2,179
Asyst Modules 1,2,3		1,989
Asyst Modules 1,2,4		1,989
Asyst Modules 1,2		1,609
ASYSTANT	Macmillan	469
ASYSTANT+	Macmillan	849
DADISP	DSP Systems	750
Feurier-PERSPECTIVE II	Alligator Transform	329
ILS-PC1	Signal Tech.	995
ILS-PC2	Signal Tech.	1,495
LabTrac II	Laboratory Microsystems	CALL
LabTrac Plus		CALL
LMS Mech. Test. Pkg.	Laboratory Microsystems	CALL
LMS Thermal Analysis		CALL
LMS Capillary Melt Rheometry		CALL
Lotus Measure		445
Metabyte D.A. & Control Tools		89
Quinn-Curtis		139
Prime Factor FFT	Alligator Transform	139
QED D.A. and Control	Hart Scientific	799
Snapshot Storage Scope		495
HEM Data Corp.		295
Snap FFT	HEM Data Corp.	295
Turbo Pascal S&E Tools		69
Quinn-Curtis		69
UnbelScope Level 2+		529
Unbel Software		329
UnbelScope Level 1		329
UnbelScope Junior		119

EQUATION SOLVERS

Eureka: The Solver	Borland	\$ 69
MathCAD	MathSoft	199
muMATH	Microsoft	185
SolveIt!	Structured Scientific Software	79
TKSolver Plus	Universal Technical Systems	395

FIRMWARE DEVELOPMENT

GENELINK	Genesis Microsystems	\$ 495
GENESCOPE/TARGET	Genesis	1,395
LINK & LOCATE	Systems & Software	329
RDmpac	Computer Innov.	219
PC LOCATE	Alda Systems	229
SOFTPROBE II/IX	Systems & Software	695

GRAPHICS/CAD

AutoESL	Systems Unlimited of California	\$ 279
AutoSHAPES	Systems Unlim.	189
Being Graphics		279
CADKEY	Micro Control Sys.	2,559
Cadfix Plus	Foresight	CALL
EASY CAD	Evolution Computing	139
FAST CAD	Evolution Comp.	1,849
FSIMPLEX	Systems Unlim.	89
Generic CADD		89
HALOVISION A	Media Cybernetics	399
HALOVISION D		399
HALOVISION		399
HYPERPLOT	JHM Int'l	459
In-A'vision	Micrografz.	239
PC MAP II	Peerless Engineering Service	949
PERSPECTIVE	Three[D] Graphics	229
ProDesign II	American Small Bus. Computers	219
TECH*GRAPH*PAD	binary engineering	259
3D CAD	CAD Soft.	315
Turbo View	Sublogic Corp.	449
Windows Clip Art	Micrografz.	79
Windows Convert	Micrografz.	79

SCIENTIFIC TEXT PROCESSING

CHEM-TEXT	Molecular Design Ltd.	\$1,500
For Mech	Shantha Software	379
Lotus Manuscript		445
PC TEX	Personal TEX	229
T ³ Scientific Word Proc. Sys.		
Software Res.		499
T ³ Graphics Font Sets		89
T ³ Laser Printer Support		79

STATISTICS

Microstat	Ecosoft	\$ 319
NMA Quality Analyst	Northwest Analytical	419
NMA STAPAK	Northwest	419
SYSTAT		499
LARGE 512K Version		CALL
Report Writer		CALL
Econometrics		CALL
Test Scoring & Analysis		CALL
File Transfer		CALL

ADDITIONAL S&E PRODUCTS

Engineer's Aide	Engineering Programming Concepts	\$ 649
LABTECH Notebook	Laboratory Tech. Corp.	759
LABTECH Real Time Access		269
LABTECH CHROM		709
PC-Matlab	The Math Works	659
POINT FIVE	Pacific Crest	279
The System Identification Toolbox	The Math Works	279

APL LANGUAGE

APL+PLUS/PC STSC		\$ 439
APL+PLUS/PC Spreadsheet Mgr.		145
APL+PLUS/PC Tools Vol 1		199
APL+PLUS/PC Tools Vol 2		65
ATLAS*GRAPHICS	STSC	339
Financial/Statistical Library	STSC	199
Packet APL	STSC	79
SCREEN ACE	ACE Software	165
STATGRAPHICS	STSC	599

BASIC LANGUAGE

BetterBASIC	Summit	\$ 139
BetterBASIC Add-ons		CALL
B7 Software Pak	Hauptauge	149
EXIM Services Toolkit		45
Finally	Komputerwerks	89
Inside Track	MicroHelp	55
MACH 2	MicroHelp	59
MicroHelp Utilities		49
Peet's a Pokes	MicroHelp	69
Professional BASIC	Morgan	75
8087 Math Support		45
Quick-Tools	BC Associates	109
QuickPak	Crescent Software	59
Scientific Subroutine Library	Peerless	99
Screen Sculptor	Software Bottling	95
Stay-Bus	MicroHelp	75
True Basic w/Run-Time		179
True Basic		105
Turbo BASIC	Borland	65

C COMPILERS

Lattice C		\$ 275
Microsoft C		269
Quick C	Microsoft	69
Turbo C	Borland	65

C UTILITIES/LIBRARIES

ADVANTAGE Graphics	Lifeboat	\$ 235
Asynch Manager	Blaise	135
CADKEY	Software Plus	249
C Tools Plus	Blaise	135
C Utility Library	Essential Software	129
Essential Comm Library		139
Essential Graphics		195
Greenleaf Functions		129
Greenleaf Comm		129
Greenleaf Data Windows		159
w/Source		299
PforCo	Phoenix	225
Pre-C	Phoenix	159
QuickScreen	Lifeboat	179
TimeSlicer	Lifeboat	275
w/Source		CALL
Vitamin C	Creative Programming	169
VC Screens		85
Windows for C	Vermont Creative	199
Windows for Data	Vermont Creative	319

FORTRAN LANGUAGE

ACS Time Series		
Alpha Computer Service		\$ 395
DIFF-EQ	Microcompatible	445
B7 SFL	Microway	239
Essential Graphics		195
For-Winds	Alpha Computer	75
Forlib-Plus	Alpha Computer	59
FORTLIB	Subrsoft	119
FORTRAN Addendum	Impulse Engr.	89
FORTRAN Addenda	Impulse	149
GRAFLIB	Subrsoft	169
HALD	Media Cybernetics	215
I/D PRO	MEF Environmental	139
Grafmatic/Pictomatic		
Microcompatibles		119
Lahy FORTRAN		CALL
Lahy Personal FORTRAN		409
Math Pac	Systemic Systems	445
Meta Window	Metagraphics	169
Meta Window Plus		239
Microsoft FORTRAN w/CodeView		279
No Limit	MEF Environmental	119
PANEL	Lifeboat	215
PANEL Plus	Lifeboat	409
PLOTMI	Subrsoft	169
PLOTMP	Subrsoft	169
RM/FORTRAN	Ryan-McFarland	409
RM/Screens	Ryan-McFarland	339
RTC PLUS	Cobalt Blue	299
Source Print	Aldebaran	85
SSP/PC	Lattice	279
Statistician	Alpha Computer	245
Strings & Things	Alpha	55

GAUSS

GAUSS Programming Language		
Aptech Systems		\$ 189
GAUSS Math & Stat Modules		
Aptech Systems		45
GAUSS Math & Stat System		339

PASCAL COMPILERS

Microsoft Pascal		\$ 189
Pascal-2	Oregon Software	369
Turbo Pascal	Borland	69

TURBO PASCAL ADD-ONS

DOO/BIOS & Mouse Tools		\$ 69
Quinn-Curtis		69
FirstTime	Spruce Technology	75
Flash-up	Software Bottling	69
Flash-up Toolkit		45
Inside Track	MicroHelp	55
MACH 2	MicroHelp	59
Metabyte D.A. Tools	Quinn-Curtis	39
Peet's a Pokes	MicroHelp	69
Report Builder	Royal American	75
S&E Tools	Quinn-Curtis	69
Screenplay	Flepus	89
Speed Screen	Software Bottling	119
System Builder	Royal American	119
Turbo Numerical Methods	Borland	89
TP2C	BISS of Louisiana	215
TURBO-ASM	BCSoft	95
Turbo Plus	TurboPower Software	49
Turbo ASYNCH PLUS	Blaise	79
Turbo Database Toolbox	Borland	49
Turbo Editor Toolbox	Borland	49
TurboEXTENDER	TurboPower Software	69
Turbo Graphics Toolbox	Borland	49
Turbo Magic	Sophisticated Software	69
Turbo Master	Hawaiian Village Software	89
Turbo Optimizer	TurboPower	115
w/Source		78
Turbo POWER TOOLS PLUS	Blaise	78
Turbo Professional	Sunny Hill Software	49
TurboHalo	IMSI	99
TurboPower Utilities	TurboPower	79

OBJECT-ORIENTED LANGUAGES

Actor	White Water Group	CALL
ADVANTAGE C++	Lifeboat	\$ 479
PforC++	Library, Phoenix	225
SmallTalk V	DigitalTalk	85

CROSS TOOLS

CASM-6502 C X-COMPILER	RELMS	\$1,299
CASM-80 C X-COMPILER	RELMS	1,299
CASM-280 C X-COMPILER	RELMS	1,299
Lattice 68000 C X-COMPILER		439
Lattice 280 C X-COMPILER		129
MICROTEC MCC68K C X-COMPILER		CALL
MICROTEC X-ASM		CALL
PASM-68K PASCAL X-COMPILER		1,489
PASM-80 PASCAL X-COMPILER		1,299
PASM-280 PASCAL X-COMPILER		1,299
RelMS		1,299
Quele 68000/68010 X-ASSEMBLER		509
RELMS X-ASMS		CALL
Uniwarc 8-bit X-ASMS SOB		265
Uniwarc 16/32-bit X-ASMS		355
Uniwarc C68020 C X-COMPILER		895

DISK/DOO/KEYBOARD UTILITIES

Norton Utilities		\$ 59
Advanced Norton Utilities		109
Keyworks 3.0	ALPHA SOFTWARE	89
Keyworks Advanced		269
Quid Analyzer		99
Bookmark	Intellisoft	79
PDisk	Phoenix	89
ADVANTAGE Disassembler	Lifeboat	275
Command Plus	ESP Software	69
FANSI-CONSOLE	Hershey Micro	65
Intelligent Backup	Sterling Software	135
Norton Commander		55
OPAL	Software Factory	89
OPART		69
O-DOS II	Gazelle Systems	59
Scroll & Recall	Opti-Tech Data	59
Taskview	Sunny Hill Software	55
Back-It	Gazelle Systems	89
Disk Optimizer	Softlogic Systems	55
FASTBACK	5th Generation Sys	135
XenoCopy-PC	XenoSoft	99

Ordering Information

We accept AMERICAN EXPRESS, MC, VISA and PERSONAL CHECKS. There is no charge on credit card or C.O.D. New York State residents must add sales tax. Shipping and handling \$3 per item. Rush service is available.

- International orders add \$10 for export preparation.
- Prices and policies may change without notice.
- Corporate Buyers call for special rates.

*Ask for details before you buy, since manufacturers won't take returns if disk seals are broken.

In the U.S. CALL
1-800-333-3141
International Orders
914-332-0756

Science & Engineering SOFTWARE CO.
55 South Broadway, Tarrytown, NY 10591

P-tral
BASIC to Pascal

\$179

TRANSLATOR

Translate your BASIC source programs to Pascal source. P-tral, now available for the IBM PC and compatibles, will translate MS-BASIC/BASICA to Turbo Pascal (Req Dos 2.0 or later w/ANSI.SYS).

Also available for the Apple II series (incl. IIGS) and converts Applesoft to Apple Pascal.

(212) 206-6490 / 924-0576
WOODCHUCK INDUSTRIES
340 WEST 17TH STREET (#2B)
NEW YORK, NY 10011

Inquiry 316

SIBEC II



The ideal solution for embedded control applications and stand alone development.

- 8052 Basic CPU
- PROM Programmer
- ISBX* Expansion Bus
- Highest Quality
- 1 Year Warranty

\$228.00 QTY 1

Call Now! (603) 469-3232

Inquire about our 8051 product development kit for the IBM PC/XT/AT.



Binary Technology, Inc.

Main St., P.O. Box 67 Meriden, NH 03770

*ISBX is a trademark of Intel Corporation.

Inquiry 26

Serial Parallel



Convert What You Have
To What You Want!

- RS232 Serial
- 8 Baud Rates
- Latched Outputs
- Centronics Parallel
- Handshake Signals
- Compact 3/4 x 4 1/2 x 1 1/2

No longer will your peripheral choices be limited by the type of port you have available! Our new High Performance 700 Series Converters provide the missing link. Based on the latest in CMOS technology, these units feature full baud rate selection to 19.2K, with handshake signals to maximize transfer efficiency. Detailed documentation allows simplified installation. Order the Model 770 (Ser/Par) or Model 775 (Par/Ser) Today!

Buffer Products Coming Soon!



only \$89.95

Connector Option \$10.00
CA Residents 8% tax
UPS Shipping \$3.00

2734-C Johnson Dr.
Post Office Box 297
Ventura, California 93006

CALL (805) 658-7466 or 658-7467

For FAST Delivery

Inquiry 294

DYNAMIC RAMS

1Mbit	100ns	\$22.00
41256	100ns	\$ 4.15
41256	120ns	\$ 3.15
✓41256	150ns	\$ 2.75
4464	150ns	\$ 3.35
✓4164	150ns	\$ 1.20

PROCESSORS		E PROMS	
8087-2	8MHz \$147.00	27812	250ns \$ 9.50
8087	8MHz \$107.00	27C256	250ns \$ 8.50
80287-6	8MHz \$166.00	27256	250ns \$ 4.75
80287-8	8MHz \$249.00	27128	250ns \$ 4.68
V-20	8MHz \$ 12.75	27C64	200ns \$ 4.95
V-30	8MHz \$ 12.75	2764	250ns \$ 3.50
STATIC RAMS		2732A	250ns \$ 3.95
6241P-15	150ns \$ 2.95	8002's (Parts in stock)	

I.C. EXPRESS

15358 Valley Blvd., City of Industry, CA 91746
Phone: 818-369-2688 (Mon-Fri • 8-5)

ORDER TOLL FREE

(800) 892-8869 • (800) 882-8181

Outside California inside California

CALL FOR CURRENT PRICES & VOLUME DISCOUNTS.

Prices Shown for Cash • MasterCard/VISA add 3% more

Prices are subject to change. Minimum order \$10.00.

California residents must add 6.5% sales tax.

Shipping & Handling: UPS Ground \$5.00, UPS Air \$7.00 (under 1 lb.)

ALL MERCHANDISE IS 100% GUARANTEED.

Inquiry 134

HARD DISK CONTROLLERS

ADAPTEC	
PC-XT Controller ST506/412	\$85
2070 PC/XT RLL	\$109
3530 SCSI to Tape QIC 36	\$99
4000 SCSI to ST506/412	\$109
4000A SCSI to ST506/412	\$129
4070 SCSI to ST506/412 RLL	\$129
4520 SCSI to ESDI	\$139
5500 SCSI to ST506/412	\$255
5580 SCSI to SMD	\$450
OTHERS	
Xebec S1410	\$109
OMTI 20C. L	\$99
DTC 510A	\$99
Shugart 1610-1, 3 or 4	\$79
W/D 1002-SHD Xebec Compatible	\$109



- Call for cable prices.
- Controller manuals \$8 each.

Computer Surplus Store "WE

Phone 408-434-1060 BUY

FAX 408-434-0931 AND

Telex 1561447 SELL"

MC/VISA/Discover/COD's (cash or certified check)

Inquiry 63

DATA SWITCHES



- High quality rotary switch
- Gold plated contacts
- All pins switched
- Fully shielded metal case
- Anti-skid feet
- Female connectors
- Ninety day warranty

RS232 TYPE (25 PIN)

#38610	TWO POSITION	27.95
#38615	FOUR POSITION	39.95
#38650	X-TYPE	43.95

CENTRONICS TYPE (36 PIN)

#38640	TWO POSITION	28.95
#38695	FOUR POSITION	42.95
#38655	X-TYPE	45.95

AUTO SWITCH

#38710	FOUR POSITION	148.50
#38760	EIGHT POSITION	198.85

WE ALSO CARRY CABLES, PRINT BUFFERS & MANY OTHER ACCESSORIES

Please call or write for our free catalog

DALCO ELECTRONICS

(513) 435-1058 • (800) 445-5342

P.O. BOX 494
FRANKLIN, OH 45005

MC/VISA Accepted

Mail Orders Please

Add \$3.00 For Shipping

Inquiry 72

FREE OFFER
of source code
if purchased before
Sept. 30, 87

AMX 86

KADAK's
engineers bring
years of practical real-time
experience to this mature

MULTI-TASKING SYSTEM (version 2.0)

for the IBM® PC, PC/XT and PC/AT

- No royalties
- IBM PC DOS® support
- C language support
- Preemptive scheduler
- Time slicing available
- Inter-task message passing
- Dynamic operations
 - task create/delete
 - task priorities
 - memory allocation
- Event Manager
- Semaphore Manager

AMX86™ operates on any 8086/88, 80186/88, 80286 system.

Demo package \$25 US
Manual only \$75 US
AMX 86 system \$295 US
(shipping/handling extra)

KADAK Products Ltd.
206-1847 W Broadway
Vancouver B.C., Canada
V6J 1Y5
Telephone: (604) 734-2796
Telex: 04-55670

Also available for 8088 / 80 / 80000

PC + MIDI = MUSIC

It's a simple equation. To plug your PC or PC-compatible into the modern world of music-making, use the complete line of MIDI software and hardware from VOYETRA TECHNOLOGIES.

- SEQUENCER PLUS: 65-track total MIDI recorder/editor.
- CONVERSION PLUS: file converter for music notation programs.
- PATCH MASTER: network organizer and sound librarian.
- OP-4001: PC/MIDI interface card.

"I've never seen a more powerful, easy-to-use music and recording system... bug-free"

(PC COMPANION)

For more information contact VOYETRA TECHNOLOGIES, Dept. PC, 426 Mt. Pleasant Avenue, Mamaroneck NY 10543, or call (914) 698-3377.

Inquiry 307

AT LAST!

ACQUIRE AND GENERATE WAVEFORMS ON YOUR PC

Sample rate: 82.000kHz
Serial: 2.000/div
Horizontal: 88.90ns/div
Channel: A A B
Display: low res.
Sample Mode: mem.

- Plug-In Waveform Acquisition and Arbitrary Generator Board (WAAG)
- Your PC becomes a dual-channel scope, as well as an arbitrary waveform signal generator
- 20 MHz to 2 KHz sample/clock rate
- Transfer data to/from disk file
- \$895.00 complete

MARKENRICH
1812 Flower Avenue
Durham, CA 91010
(818) 358-9190
TLX: 288727
MRK UR

Inquiry 170

Inquiry 144

Expand your options!

DISK UPGRADE BIOS

for ATs

Forget Drive Table Limits!

- Use any Compatible Drive on the AT Controller
- For DOS, UNIX, XENIX...
- Plug-in Installation
- Includes set-up and low-level format

DUB-14

GOLDEN BOW SYSTEMS

\$95
\$3 shipping/handling
California orders add 6%

2870 Fifth Avenue
Suite 201
San Diego, CA 92103
619/298-9349



Inquiry 112

Get the whole story on graphics terminal emulation.



To find out more about software that lets your PC emulate TEKTRONIX™ 4105/6/7/9 and DEC VT100™ terminals, call or write:

GRAFFPOINT

4340 Stevens Creek Blvd., Suite 280,
San Jose, CA 95129 (408) 249-7951

Inquiry 113

8051, 8096, 68HC11, 68008 SINGLE BOARD COMPUTERS

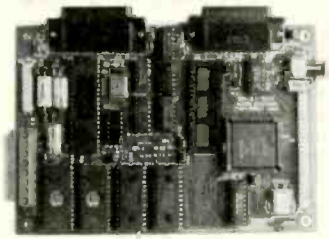

We feature a series of single board computers for process control applications. Available as bare boards or assembled and tested. Optional EPROM resident System Monitors and BASIC interpreters are also available.

ALLEN SYSTEMS
2151 Fairfax Road
Columbus, Ohio 43221
614-488-7122

IBM PC/VT220

EM220 • VT220, VT102 emulation
\$169

- File Transfer
- 132 Column modes
- Color Support
- Hot Key

TEK 4010/4014

EM4010 • Tektronix 4010 emulation
\$249

- VT220, VT102 emulation
- Picture files
- High resolution hardcopy
- Supports IBM, IBM Enhanced, Hercules, Tecmar and AT&T.

DCS
3775 Iris Ave., Suite 1B
Boulder, CO 80303
(303) 447-9251

Trademarks: VT100 - Digital Equipment; IBM PC, XT - IBM Corp.

Inquiry 82

IEEE 488

(GPIB/HPIB)

- Controllers
- Buffers
- Converters
- Extenders
- Interface Boards



for PCs, Macintosh, HP plotters, instruments, printers, etc.

Call or send for your **FREE Technical Guide**

LOtech (216) 439-4091

23400 Aurora Road
Cleveland, Ohio 44146

Inquiry 133

ICs PROMPT DELIVERY!!!

SAME DAY SHIPPING (USUALLY)
QUANTITY ONE PRICES SHOWN FOR JULY 26, 1987

OUTSIDE OKLAHOMA: NO SALES TAX

DYNAMIC RAM		
1Mbit	1000Kx1	100 ns \$26.50
1Mbit	256Kx4	120 ns 32.00
51258	*256Kx1	100 ns 6.95
4464	64Kx4	150 ns 3.50
41256	256Kx1	80 ns 4.95
41256	256Kx1	100 ns 4.40
41256	256Kx1	120 ns 3.30
41256	256Kx1	150 ns 3.20
4164	64Kx1	150 ns 1.50
EPROM		
27512	64Kx8	200 ns \$11.25
27C256	32Kx8	250 ns 6.65
27256	32Kx8	250 ns 5.50
27128	16Kx8	250 ns 4.75
STATIC RAM		
43256L-12	32Kx8	120 ns \$12.75
5565PL-15	8Kx8	150 ns 3.30

640K MOTHERBOARD UPGRADE: Zenith 150, IBM PC, XT, Compaq Portable & Plus, hp Vectra

8087-2 \$160.00
80287-8 \$250.00
80287-8 80387-16 \$540.00

OPEN 6 1/2 DAYS, 7:30 AM-10 PM SHIP VIA FED-EX ON SAT.

SUNDAYS & HOLIDAYS: SHIPMENT OR DELIVERY VIA U.S. EXPRESS MAIL

SAT DELIVERY INCLUDED ON FED-EX ORDERS RECEIVED BY 7:30 AM '87 \$4.95 FR. P.T. \$10.50/2 lbs

MasterCard VISA or UPS CASH COD

Factory New, Prime Parts **µP** MICROPROCESSORS UNLIMITED, INC.
24,000 S. Peoria Ave. (918) 267-4961
BEAGS OK 74421

No minimum order. Please note that prices are subject to change. Shipping & insurance extra. It is up to you for packing materials. Orders received by 9 PM CST can usually be delivered the next morning, via Federal Express Standard Air at \$4.00, or guaranteed next day Priority One at \$10.50! All parts guaranteed.

Inquiry 177

TURBO 10MHz 1MB AT/XT

30-DAY GUARANTEE

FULLY IBM COMPATIBLE

PHOENIX BIOS

OPEN 7 DAYS

AT \$1,150

11800 SE SEAGATE ST 251-4048

486 RES (720x350) AMBER MONITOR • INTEL 80286 670 MHz • ONE 1MB RAM ON BOARD • PHOENIX BIOS • HERCULES EMUL. HIGH GRAPHICS CARD • PRINTER PORT • SERIAL PORT • OPERATES MS-DOS 2.05 • KEYB. UNIQ. ON BOARD • 4 3.5" DISK • HD CONTROLLER 2FD2HD • ENHANCED KEYBOARD W/LED • 200 W. POWER • ON BOARD CLOCK CAL. ENDOR • 1.2MB floppy • HARDWARE RESET • SPEAKER • 80287 SOCKET • ACCEPTS ALL IBM PARTS • OPT. I/O ADD-ON • MULTITASKING • FULLY SUPPORTED • MANUALS • ONE YEAR PARTS LABOR

XT \$650

9900 SE SEAGATE ST 251-4048

486 RES (720x350) AMBER MONITOR • INTEL 80286 4.77MHz • OPTIONAL HD 200 OR 400MB • PHOENIX BIOS FASTER THAN IBM PC • 64KB ON BOARD • PHOENIX BIOS • 150 W. • HERCULES EMULATION GRAPHICS CARD • PRINTER PORT • OPERATES MS-DOS 3.0 • SERIAL PORT • HD CONTROLLER 2FD2HD • 2 FD CONTROLLER PRINTER GAME SERIAL PORTS • TIME CAL. ENDOR • 40 KEYPAD W/LED • 1.2MB 360K FLOPPY DRIVES • 80287 SOCKET • SPEAKER • 8 3.5" DISK • ACCEPTS ALL IBM PARTS • FULLY SUPPORTED • MANUALS • ONE YEAR PARTS LABOR

386 S & MULTI USER SYSTEMS PLEASE CALL

PORTABLE AT&T SYSTEMS TOO

PC PRIME SYSTEMS, INC
800-451-5278
VISA/MC/AE

59 PRINCE ST. BROOKLINE, MA 02146 (800) 451-5278

135 W. 26TH ST. 8TH FL. NEW YORK, N.Y. 10001 (212) 627-4485

6951 WARRIOR ST. SUITE 294 HUNTINGTON BEACH, CA 92647 (800) 451-5279

Inquiry 218

2400 baud

300 1200 2400 MODEM **\$160**

XT/AT, Apple, Atari, Commodore &

*Fully Hayes compatible
*Auto dial, auto answer, w 8 LED, speaker, Aluminum case



(SAME AS ABOVE)

300 1200 **\$99**

300 1200 for XT AT INTERNAL MODEM **\$69**

*Add 7% shipping. 10 days money back guarantee (less \$15 ea for restocking & shipping charge)

FOSTER TECHNOLOGY:
*#4, 222 H St., Blaine, WA 98230
Phone: (206) 332-5081
*Phone: (604) 684-2368 CANADA
(Add 16% for Canadian Orders)

Inquiry 324

RAMport™ Expand Retrofit Test

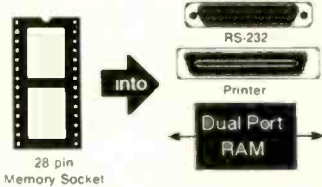

28 pin Memory Socket

Existing Memory IC

Ribbon Cable

RAMport Socket

I/O Modules

RS-232 Printer

Dual Port RAM

“the last minute problem solvers”
(619) 566-1892
HiTech Equipment
9560 Black Mountain Rd., San Diego, CA 92126

Inquiry 124

END OF SUMMER CLEARANCE SALE

SUMMER CLEARANCE SPECIALS



CAT™ 4.77

BASE SYSTEM

- 256K (Optional 640K)
- 150 watt Power Supply
- AT Style Keyboard
- FDC w/360K Floppy
- 8087 Socket

\$34900

4.77 Mhz

OPTION A	OPTION B	OPTION C
Base System Plus Amber Mono Monitor Graphics Compatible Mono Card Parallel Printer Port	Base System Plus Color RGB Monitor Graphics Compatible Color Card Parallel Printer Port	Base System Plus Amber Mono Monitor Graphics Compatible Mono Card Parallel Printer Port 20Meg Hard Drive
\$49700	\$68800	\$78900



ARCHIVE Tape Backup

- 40 Meg
- AT or XT
- Cassette Software

\$39500

40Meg Hard Drive

- 33 Mil. Sec.
- 6 Month Warranty

\$43900

Add \$10 for Cables, Rails & Manual

TANDON 20 Meg

- 1/2 HT
- 1 Year Warranty
- Omti Controller

\$27900

HYUNDAI Monitor

- 12" Amber
- Hi-Res Tilt & Swivel

\$7900

150 Watt Powr Supply

UL Approved
Direct PC Replacement

\$5900

EVEREX EGA

- Autoswitch
- Short Card
- EGA or Mono

\$15900



CAT™ 8MHZ

- #### BASE SYSTEM
- 256K (Optional 640K)
 - 150 Watt Power Supply
 - AT Style Keyboard
 - 4.77 or 8 MHZ
 - Keyboard Selectable
 - FDC w/360K Floppy
 - 8087 Socket

\$39900

4.77 or 8 Mhz

OPTION A	OPTION B	OPTION C
Base System Plus Amber Mono Monitor Graphics Compatible Mono Card Parallel Printer Port	Base System Plus Color RGB Monitor Graphics Compatible Color Card Parallel Printer Port	Base System Plus Amber Mono Monitor Graphics Compatible Mono Card Parallel Printer Port 20Meg Hard Drive
\$53700	\$72800	\$82900



Hard Drives	Floppy Drives
<p>Seagate</p> <p>20Meg ST225 ... \$31900 30Meg ST238 ... \$35900</p> <p>Above Drives come with WD Controllers & Cables</p> <p>40Meg ST251 40 Mil. w/partioning software \$48900</p> <p>WESTERN DIGITAL</p> <p>WA2 FDC/HDC for AT \$16900 WX2 HDC for XT \$8900 27X HDC (RL) for XT \$10900</p> <p>Hard Disk Controller Cables \$50 AT Mounting Rails & Screws \$50</p>	<p>TOSHIBA</p> <p>720K 3 1/2 w/mounting \$12900</p> <p>Tandon</p> <p>TM100-2 360K full HT. \$8900 IBM Logo 360K 1/2 HT \$8900</p> <p>Fujitsu</p> <p>1.2 Meg \$10900</p> <p>TEAC</p> <p>55 BV 360K \$9400</p>

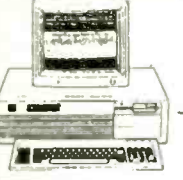

CAT™ 10MHZ

- #### BASE SYSTEM
- 256K (Optional 640K)
 - 150 Watt Power Supply
 - AT Style Keyboard
 - 360K Floppy w/Controller
 - AT Style Case w/Reset & Turbo Switch

\$44900

4.77 or 10 Mhz

OPTION A	OPTION B	OPTION C
Base System Plus Amber Mono Monitor Graphics Compatible Mono Card Parallel Printer Port	Base System Plus Color RGB Monitor Graphics Compatible Color Card Parallel Printer Port	Base System Plus Amber Mono Monitor Graphics Compatible Mono Card Parallel Printer Port 20Meg Hard Drive
\$59700	\$78800	\$88900



Coprocessors & Memory	Tape Backups	Modems
<p>intel</p> <p>8087-3 5Mhz \$9900 8087-2 8Mhz \$14400 80287-6 6Mhz \$17900 80287-8 8Mhz \$23900 80287-10 10Mhz \$28800 80387 16Mhz \$47400</p> <p>SAMSUNG</p> <p>41256 120ns Set of 9 \$3600 41256 150ns Set of 9 \$2600 4164 150ns Set of 9 \$1300 41256 100ns \$15600</p>	<p>EVEREX™</p> <p>Excel-Stream 60 Meg \$59500 120 Meg \$114500</p> <p>Add 150% for External Versions—Software Incl.</p> <p>IRWIN</p> <p>10 Meg 110D \$27800 20 Meg 120D \$38800 40 Meg 145D \$49800</p> <p>Extra Cartridge \$2900 Software Included</p>	<p>EVEREX™</p> <p>1200Baud Internal \$9700 2400Baud Internal \$19700</p> <p>XT & AT Hayes Compatible Software & Cables Incl.</p> <p>Expansion Memory</p> <p>intel</p> <p>Above 286 w/512K-2MB \$35900 Above Pent/Ser 286 512K-2MB \$38800 Above Piggy Back 512K-2MB \$29900</p>

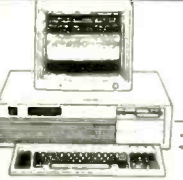

CAT™ 286-10

- #### BASE SYSTEM
- 640K (120 NS)
 - 200 Watt Power Supply
 - AT Style Keyboard
 - Western Digital Controller
 - Toshiba 1.2 meg Floppy
 - Legal Bios w/manuals
 - Systems Documentation
 - 1 Year Warranty

\$99900

6Mhz or 10Mhz

OPTION A	OPTION B	OPTION C
Base System Plus Amber Mono Monitor Graphics Compatible Mono Card Parallel Printer Port 30Meg 40Meg	Base System Plus Color RGB Monitor Graphics Compatible Color Card Parallel Printer Port 30Meg 40Meg	Base System Plus EGA H/RS Monitor EGA Interface Card Parallel Printer Port 30Meg 40Meg
\$1585 \$1722	\$1781 \$1931	\$2043 \$2188



Printers	Monitors
<p>CITIZEN™</p> <p>120D 120CPS w/NLO \$17900 MSP10 160CPS \$27900 MSP15 160CPS 15" Carriage \$35900 MSP20 200CPS \$31900 TRIBUTE 224 24 pin 200CPS \$63500</p> <p>Panasonic</p> <p>10801 120CPS w/NLO \$17900 10901 160CPS w/NLO \$20900 10921 180CPS w/NLO \$33900</p> <p>TOSHIBA</p> <p>321SL 24 pin \$54900</p> <p>EPSON™ CALL</p>	<p>SAMSUNG/Hyundai</p> <p>1252 Amber Monochrome \$7900 Color RGB 640X200 \$25900 EGA 640X350 \$36800</p> <p>NEC</p> <p>Multisync \$54900 w/GB1 Card \$88800</p> <p>MONITOR INTERFACES</p> <p>Everex EGA w/par \$19800 Mead EGA w/par \$14900 ATI EGA Wonder \$25900 Hercules Compatible \$6800 Mono or Color</p> <p>Everex EGA (Autoswitch) \$15900</p>

CALL FOR CUSTOM CONFIGURATION OF ALL SYSTEMS
Guarantee Lowest Price With Highest Quality Systems & Service

ALL TRADEMARKS ARE REGISTERED
with their respective companies

800-654-7762

SALES
7AM—6PM PST

702-294-0204

Customer Service • Order Status
9AM—4PM PST



1000 Nevada Highway • Unit 101
Boulder City, Nevada 89005

NO SURCHARGE FOR MC/VISA

TERMS:
MC • VISA • COD • CASH
Purchase Orders from Qualified Firms
Personal Checks • AE add 4%



SHIPPING:
UPS • Federal Express

Incredible!
64K Printer Buffer
 with cable

30-day money back guarantee plus 1-year warranty

\$69 Plus \$3 shipping & handling

Limited Offer-Order Today



Works with any standard Centronics parallel interface • Reset button • Multiple copy repeat function • Auto diagnostics • Self-test

Order by Check/MO or VISA/MC/AX

CENTRAL
COMPUTER PRODUCTS

Call Toll Free
 USA: 800-533-8049
 CA: 800-624-5628

330 Central Avenue • Fillmore, CA 93015

Inquiry 44

PAL/EPROM PROGRAMMER CARD
 For PC/XT/AT Systems

NEW -- VERSION 2 OF SOFTWARE AND HARDWARE

-Programs 20 and 24 Pin MM1, NS, TI, AMD, ALTERA, CYPRESS, RICOH, and PANATEC PALS. Supports EPLO, polarity, RA, and shared product term types. Functions include: Read, Write, Verify, Protect, Edit, Print, and File load and save of program. JEDEC supported. -Software Included

\$475



100MHZ LOGIC ANALYZER CARD
 For PC/XT/AT Systems

\$1199

24 Channels at 25KHz-25MHz
 4 Channels at 100 Mhz
 Internal Clock up to 100 Mhz
 External Clock up to 25 Mhz
 Threshold Voltage TTL, ECL, or variable from -10 to +10v
 Can Stack Multiple Boards
 All Software Included

CALL NOW FOR ORDERS AND TECHNICAL INFO (201) 994-6669

Link Computer Graphics, Inc. 4 Sparrow Dr., Livingston, NJ 07039. TLX: 910249305 LINK COMPUTER

Inquiry 154

Presto!
A Link to Mainframe Graphics



Find out how our whole family of EMU-TEK graphics terminal emulation software makes good sense for the work you do. Call today for more information.

FTG DATA SYSTEMS

(714) 995-3900
 (800) 962-3900 (800) 972-3900 (Calif.)
 10801 Dale St., Suite M-2
 Stanton, CA 90680

Inquiry 104

DISKETTE

BOXED **33¢** BULK **26¢**

Boxed Diskettes are prod 10 to a plain white box and include sleeves, labels, & Hub ring 100% error free. Lifetime warranty. Major US Mfrs.

5 1/4 DSDD Sleeves 2¢ Labels & Tabs 2¢

Your cost **\$3.30/box** Add \$3 per 100 diskettes for shipping & handling

5.25HD .99
 3.50SS .99
 3.50DS .99

(213) 479-0345

Data Bureau Inc.
 1731 So. LaCienega Blvd., Los Angeles, CA 90035

Please call as prices change. We will beat any advertised price on diskettes.

Inquiry 347

IBM PC * Relay Control Card



Control All Types Of Electrical/Electronic Devices

- Motors & Heaters
- Solenoids & Lamps
- Security Devices
- Temperature Controls
- Fans/Blowers
- Energy Controls

Fully Addressable
 Demo Disk Available
 Solid State Relays (8)
 1 Amp/280 VAC

ORDER NOW
 Type 8603 \$149.00
 Fuses and LED Indicators Optional

42 Pleasant Street
 Stoneham, MA 02180
 (617) 438-5300

EI&S

*Registered Trademark of IBM Corp.

Inquiry 348

PC → IEEE
ONLY \$99.95!

Now you can use an IEEE printer or plotter with your PC compatible without having to buy an expensive IEEE card! The IBM to IEEE Printer Port Adaptor from Omnitronix, Inc. is a cable and disk which reconfigures your PC parallel port to operate as an IEEE compatible printer port. You don't need to buy a new card at all! Great compatibility with all software! There is no better deal anywhere for interfacing your IEEE printers and plotters! Call us today at (206) 624-4985 to order or for more information. 30 day money back guarantee. VISA, MC, COD. Dealers, distributors, and OEMs welcome. Omnitronix is an experienced custom developer and welcomes the opportunity to quote on any custom applications or projects.

Omnitronix, Inc.
 760 Harrison St.
 Seattle, WA 98109

Inquiry 202

Add-Ons for the Blind

What you add on to your computer, if you're a blind operator, is almost more important than the computer itself.

Scanners, modems, braille printers, speech synthesizers, braille output devices and a host of other peripherals are described in "Add-Ons: The Ultimate Guide to Peripherals for the Blind Computer User."

The product reviews contained in this book are written by those who know them best—blind computer users.

\$16.95 for braille or cassette
 \$19.95 for print.

Send orders to:

National Braille Press Inc.
 88 St. Stephen Street, Boston, MA 02115
 (617) 266-6160

NBP is a nonprofit braille, printing and publishing house.

Inquiry 251

ROSE ELECTRONICS DATA SWITCHES



SHARE computers, printers, any parallel or serial device
 ELIMINATE cable swapping
 INEXPENSIVE way to network
 COMPATIBLE with all computers
 Businesses, Schools, Homes

WE ALSO OFFER:
 Data Buffers, Line Drivers, Modems, Protocol Converters, Parallel - Serial Converters, Cables, Computers, Printers, Disk Drives, and more

AUTOMATIC - CARETAKER is ideal for a business or school to share a printer or modem among many computers. Operation is fully automatic with no software required. Parallel or Serial 4 channels - \$295 8 channels - \$395

MANUAL - HARD SWITCH is operated with the flip of a switch. 2.2 and 2.4 models allow simultaneous communication.
 Serial 1-2 - \$59 1-4 - \$99 2-2 - \$109 2-4 - \$169
 Parallel 1-2 - \$79 1-4 - \$139 2-2 - \$119 2-4 - \$199
 LED and spike protection on serial models add \$20.

CODE ACTIVATED - PORTER connects one computer to multiple peripherals. A software code selects the peripheral. Parallel or Serial 4 channels - \$295 8 channels - \$395
 Buffer option 64K - \$100 256K - \$250

REMOTE - TELEPATH connects multiple computers to multiple peripherals. A selector at each computer or terminal chooses up to 4 peripherals and displays busy status.
 4-4 - \$495 4-8 - \$795 selector - \$39.

Give a Rose to your computer

ROSE ELECTRONICS (713) 933-7673
 P.O. BOX 742571 MC & VISA Accepted
 HOUSTON, TX 77274 Dealer Inquiries Invited
 CALL US FOR ALL YOUR INTERFACE NEEDS

Inquiry 84

Dynamic Electronics CO. *Where the CUSTOMER Comes First!*

8087 - 5, 8, 10 MEG
80287 - 6, 8, 10 MEG
80387 - 16, 20 MEG
64K • 256K • 128K
V20 • V30

No refund, only exchange
 Exchange good for 30 days unless manufacturer warranties merchandise longer.

Phone: (714) 582-1224
FAX: (714) 582-3780

Authorized

COMB

Liquidator

XEROX 6064 PERSONAL COMPUTER

XEROX... They Set The Standards!

For over 20 years Xerox has been the world leader in office products and copying equipment. They have set standards that others can only imitate. The Xerox 6064 Personal Computer was designed to meet the demands of business, professional, and personal computing today, and into the future! We are proud to offer this complete Xerox System at a remarkably **LOW price**. Compare for yourself... then buy your Xerox 6064 from C.O.M.B.!

Get the Xerox Advantage! The Xerox PC offers you the advantage of running IBM™ compatible MS™-DOS, so you can run the hundreds of business and professional software programs available today! And the Xerox PC is easy to use! It's designed to get you up and running as quickly as possible with computer-aided instruction and superior documentation covering all aspects of personal computing.

Xerox... Service You Can Count On! If you're considering an IBM™-compatible, don't be misled by price alone! The system we are offering is a **complete system**... very easy to hook up and use... and very affordable. But more than that, each system we sell is backed by Xerox service and support. When you buy this system, your name and computer's serial number is automatically registered with Xerox. Should you need service or advice, a network of over 150 service centers stands ready to help you. Before you buy... compare! Xerox is your best value! Check all these features:

- IBM™-PC/XT Compatibility.
- 256KB Memory Features an 8MHz Intel 8086-2 Microprocessor for Faster Speed, Less Waiting Time.
- Two 5¼" Floppy Disk Drives, 360K Each.
- Seven Expansion Slots, Plus a Serial Port for Communications or Printer, and Parallel Printer Port.
- High-Resolution 640 x 400 Pixels Monochrome Monitor, with 12" Diagonal Non-Glare Screen, Swivel and Tilt Base.
- Standard 83-Key PC Keyboard with Mouse Interface (Mouse Not Included.)
- Comes with ScreenMate™, a User Friendly Guide to the Functions of the MS™-DOS Operating System. ScreenMate™ is Menu Driven... No Need to Remember Complicated Commands!



Lets You Select from a Menu and Provides Clear On-Line Instructions If You're Confused About Your Next Step.

Complete Tutorial Software and Manuals Included:

- "Getting Started" Booklet.

- Four Reference Guides.
- Four Software Programs: Two X-Cel™ Training Disks, Two Diagnostic Disks, GW™-BASIC Interpreter, and MS™-DOS/ScreenMate™ Operator's Guide.
- Twenty Blank Disks.

Over 150 Service Centers Nationally.

Manufacturer's Limited 90-Day Warranty on Parts/Labor.

List Price **\$2224.80**

\$999

Priced At Only

Item H-2730-7129-232 Shipping, handling: \$49.00 ea.

Memory Expansion Board for Xerox 6064 Personal Computer: Expands the memory to 640K.

List: **\$249.00**
Priced At **\$129**

Item H-2730-7128-978 Shipping, handling: \$3.50 ea.

XEROX, ScreenMate™ and the identifying numbers herein are trademarks of Xerox Corporation. IBM™, IBM™ PC, and PC™-DOS are trademarks of International Business Machines Corporation. MS™-DOS is a trademark of Microsoft Corporation.

Toll-Free: 1-800-328-0609

Credit Card customers can order by phone, 24 hrs. a day, 7 days a week.



SEND TO: Item H-2730
 C.O.M.B. Direct Marketing Corp.
 1405 Xenium Lane N/Minneapolis, MN 55441-4494
 Send Xerox Personal Computer(s) Item H-2730-7129-232 at \$999 each, plus \$49 each for ship, handling.
 Send Xerox Memory Expansion(s) Item H-2730-7128-978 at \$129 each, plus \$3.50 each for ship, handling.
 (Minnesota residents add 6% sales tax. Sorry, no C.O.D. orders.)
 My check or money order is enclosed. (No delays in processing orders paid by check.)
 Charge: VISA® MasterCard® DiscoverSM American Express®
 Acct. No. _____ Exp. / _____

PLEASE PRINT CLEARLY

Name _____
 Address _____
 City _____
 State _____ ZIP _____
 Phone (____) _____
 Sign Here _____

Sales outside the 48 contiguous states are subject to special conditions. Please call or write to inquire.

COMB COMB COMB COMB COMB COMB COMB COMB COMB

JADE COMPUTER



Continental U.S.

(800) 421-5500

Inside California

(800) 262-1710

Technical Support

(213) 973-7707

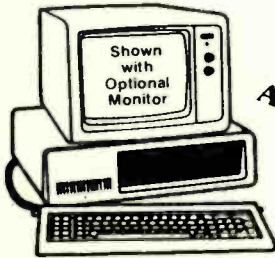

F.C.C. APPROVED

TURBO-AT

- 640K of RAM
- 4.77 or 8 MHz
- 150 Watt Power Supply
- Deluxe keyboard
- 360K Disk Drive
- 8 Expansion Slots
- 8087 Socket
- One Year Warranty

- 640K of RAM Expands to 1 MB
- 200 Watt Power Supply
- AT-Style Keyboard
- Hard Disk Controller
- 1.2 MB Disk Drive
- One Year Warranty

\$998

SATISFACTION GUARANTEED OR YOUR MONEY BACK!
8 MHz TURBO-XT

\$398

- OPTION A**
- High Resolution Amber Flat Screen
 - High Resolution Graphics Card
 - Parallel Printer Port

ADD \$148

- OPTION B**
- Hi-Res RGB Color Monitor
 - High Resolution Graphics Card
 - Parallel Printer Port

ADD \$298

- OPTION C**
- 21.3 Megabyte Hard Disk Drive
 - Dual Hard Disk Controller Card

ADD \$298

NEW!

IBM PS/2

\$1338
List Price \$1695

HARD DISK DRIVE

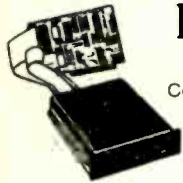

Hard Disk, Controller (PC) and Cables

20 MB 1/2 Ht Kit **\$298**

30 MB 1/2 Ht. Kit **\$349**

30 MB for AT...\$499 40 MB for AT...\$559

10 MB Full Ht Kit

\$199

HARD DISK ON A CARD

21 MB Card

\$358

- 21.3 MB Formatted
- Lowpower

40 MB Card

\$498

- Head Park Zone
- Plated Media
- Light 2.4 Lbs.

360K DISK DRIVE

Built By Alpine Electronics to IBM Specifications, same as Qume 142

\$65



- 360K
- 48 TPI
- Double-sided
- Double density
- Half Height

3 1/2" DISK DRIVE

FOR YOUR PC/XT/AT

720K Disk Drive for Mass Storage or for Down Loading to your Lap-Top or New IBM PS/2. Requires DOS 3.20

\$149

Includes Free Mounting Kit

360K DISK DRIVE

Tandon TM100-2 Full Ht. Replacement Drive for Your IBM PC or XT

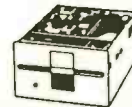

\$78

DISK DRIVE FOR YOUR APPLE

AS LOW AS **\$119**



- 20 MB Hard Disk _____ \$799
- Iic 1/2 Hard Disk Drive _____ \$119
- Ile 1/2 High Disk Drive _____ \$119
- Ile, II+ Disk Drive _____ \$129
- Grappler Printer Card _____ \$89
- II+ 16K RAM card _____ \$39
- 1 MB RAM Card w/OK _____ \$129
- II+, Ile Printer Card & Cable _____ \$49
- Serial Board _____ \$69

1200 BAUD MODEM

- Internal 1200 Baud Card with Software _____ \$78
- External 1200 Baud _____ \$119
- Internal 2400 Baud Card with Software _____ \$199
- External 2400 Baud _____ \$199
- Hayes 1200B Internal Card w/o Software _____ \$329
- Hayes 1200B Internal Card w/Smartcom II _____ \$359

\$78

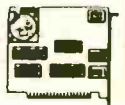

- Hayes Smartmodem 1200 _____ \$389
- Hayes 2400B Internal Card w/Smartcom II _____ \$549
- Hayes Smartmodem 2400 _____ \$589

MICROSOFT MS-DOS 3.21

Including GW-BASIC Supports 3 1/2" Drive

\$88

DELUXE KEYBOARD DRAWER

Ball-Bearing Slides with Ergonomic Palm Rest

\$48

Samsung Hi-Res MONOCHROME FLAT SCREEN

Amber or Green Monitor with Free Tilt-N-Swivel Base

\$98

MicroSpeed Fast 88 7 MHz Turbo Board For Your Turbo

\$99

EPSON® PLOTTER FOUR PEN/FOUR COLOR

\$198

LIST PRICE \$599

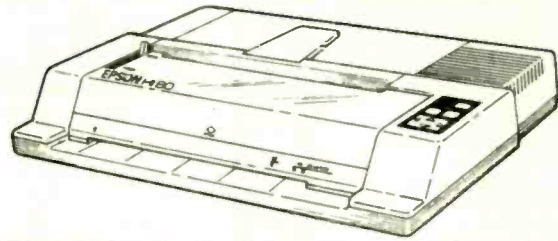

- 4 Waterbase Pens\$5
- 4 Oil Base Pens\$5
- 4 Ball Point Pens\$8
- 100 Sheets Coated Paper\$5
- 10 Sheets Overhead\$5
- Transparency Film\$6
- Top Rated Business Graphics Software Package for PC\$29
- Parallel PC Cable\$19
- Serial Kit\$89



"The Epson Hi-80 is the final choice. It makes a name for itself at the low end of the price scale (\$599) and the top end of the performance scale."
PC MAGAZINE

- Fast - 9 Inch Per Second
- Accurate - .1 mm Step Size
- Four Pen/Four Color
- Automatic Pen Capping
- Standard Parallel Interfacing
- Accepts Paper or Transparencies
- One Year Epson Warranty

EPSON® PRINTER

\$148

LIST PRICE \$299

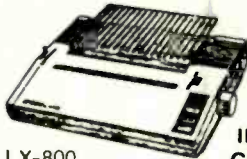

Limited Quantity

FX-86e EX-800 LQ-800 LX-800
FX-286e EX-1000 LQ-1000 LQ-2500

IN STOCK
Call for Our
Low Low Prices

hp HEWLETT PACKARD LaserJet II

\$1748

List Price \$2495



- New Improved Model
- 512K RAM up to 4 MB

- 8 Page Per Minute
- 300 DPI Graphics

HI-RES RGB MONITOR

\$289

LIST PRICE \$699

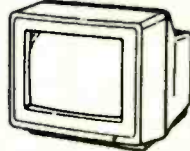

- Samsung 14" Monitor
- 640 x 240 Non-glare Tube

- 16 Color .41 mm Dot Pitch
- Free Tilt & Swivel Base

EGA PACKAGE CARD & MONITOR

\$499

LIST PRICE \$999

Hi-res EGA video card...\$149
Hi-res EGA monitor...\$369

- Samsung Dual Mode Monitor
- Non-glare .31 mm Dct Pitch
- 640 x 350, 640 x 200
- EGA, CGA, MDA & HGA
- 100% IBM Compatible
- 256K of Video RAM

NEC MULTISYNC

\$529

13" Color Monitor

NEC MULTISPEED

\$1488

Lap-Top Computer

DAISYWHEEL PRINTER LETTER QUALITY

Limited Quantity

\$198

LIST PRICE \$499

- 22 cps. Intelligently Bi-directional
- Diablo 630 Compatibility
- Proportional Spacing Plus 10, 12, 15 Pitch
- Built-in 2K Buffer Expands to 6K
- Uses Standard Ribbon and Wheel

Parallel & Serial Option.....\$50

MOUSE With Pop-up Menus

\$69



Software Options

Dr. Halo Desktop Publishing \$18
Graphics \$64

40 MB TAPE BACK-UP

\$378

LIST PRICE \$795

No-Slot Clock

For Your PC-XT (Clone) or Apple

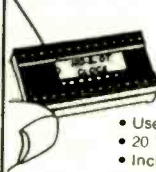

\$49

- Uses No Slots
- 20 Year Battery
- Includes Software

Plug-in Clock Board for PC.....\$49

INTEL

Math Co-Processor

8087-3 (5 MHz)	\$109
8087-2 (8 MHz)	\$159
8087-1 (10 MHz)	\$205
80287-6 (6 MHz)	\$185
80287-8 (8 MHz)	\$255
80287-10 (10 MHz)	\$305
80387	\$588

JADE COMPUTER

4901 W. Rosecrans Ave. Box 5046
Hawthorne, CA 90251-5046



Prices at our seven store locations will be higher.
We accept cash, checks, credit cards or purchase orders from qualified firms and institutions. Minimum prepaid order \$15.00.

PLACE ORDERS TOLL FREE!

Continental U.S.A. (800)421-5500

Inside California (800)262-1710

Ca. & Tx. residents add sales tax. Prices & availability subject to change without notice. Shipping & handling charges via UPS Ground 50¢/lb. UPS Air \$1.00/lb. Minimum charge \$3.00.



UNIVERSAL EPROM PROGRAMMER \$495!!

- * Built in timer eraser optn; foam pad area
- * Menu selection; No personality modules
- * User friendly softw; Complete help menu
- * Direct tech. support; Full 1 yr. warranty
- * Stand alone duplication & verify;
- * Quick pulse algorithm: 27256 under 60 sec
- * All 24/28 pins to 27011 & CMOS E(EPROMS
- * Micros: 8741, 2, 4, 8, 9, 51, 52, 55, 9761 & CMOS
- * Auto baud RS232 to 19.2k; Free PC drivers
- * Offset/split Hex, Binary, Intel & Motorola
- 8, 16 & 32 bit files; Kits from \$95!

B&C Microsystems
355 W. Olive Ave., Sunnyvale, CA 94086
* Ph 408-730-5511 Visa & MC

Inquiry 38

NEW IMPROVED EPROM PROGRAMMER

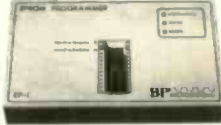

STILL JUST \$349

- Now supports over 250 specific EPROM's and EEPROM's from AMD, Intel, SEEQ, TI, Fujitsu, Hitachi, Toshiba, and 21 others.
- Programs 87C51, 8749, 8741A, 8742 and other microcontrollers with optional heads
- Splits 16- and 32-bit files
- 30 day money back guarantee.
- Free PCDOS software runs up to 38,400 baud.
- Gold Textool ZIF socket.
- Same day shipment.

CALL TODAY FOR MORE INFORMATION
BP MICROSYSTEMS
10681 Haddington, #190 / Houston, TX 77043
(713) 461-9430 (800) 225-2102
Telex: 1561477

Inquiry 33

Intel RUN ISIS Very Fast
12.5 MHZ Clock Speed!



Our co-processor card plugs into your PC or PC/AT. With the included software you can run your ISIS-II development tools, such as ASM80, PLM51, etc. Serial communications program for PC-Intel file transfer included. \$495 gets you a complete 6 mhz system. Clock speeds of 10 and 12.5 mhz also available. We have the best and fastest products in this area.

Z-World
2065 Martin Ave #110
Santa Clara, CA 95050
(408) 980-1678

In Germany: iSystem Tel: 08131/1687

Inquiry 322

UPS - DEPOT

WE SPECIALIZE IN PRODUCTS THAT CORRECT AC POWER PROBLEMS SUCH AS HIGH VOLTAGE, LOW VOLTAGE, TOTAL POWER FAILURE, LINE NOISE, LINE TRANSIENTS OR ANY COMBINATION OF THE ABOVE. WE DISTRIBUTE UPS-TECH, MINUTE MAN, EMERSON AND RTE DELTEC PRODUCTS, AMONG OTHERS.

STAND-BY POWER SYSTEMS
FROM 200 VA TO 2 KVA

UNINTERRUPTABLE POWER SYSTEMS
FROM 1 KVA TO 45 KVA

AC LINE CONDITIONERS
FROM 500 VA TO 3 KVA

SURGE PROTECTORS WITH EMI/RFI FILTER
4 OUTLETS AND 6 OUTLETS

"COMPARE THESE INTRODUCTORY PRICES"

- UPS-TECH STAND-BY 500 VA \$ 499.00
- UPS-TECH CONTINUOUS TYPE UPS 1 KVA \$1,499.00
- UPS-TECH STAND-BY 300 VA \$ 399.00
- SURGE PROTECTOR WITH EMI/RFI FILTER 6 OUTLETS \$ 35.00

• **DEALER INQUIRIES WELCOMED**
• **EXPORT PRICES**

CASH PRICES INDICATED. ALL ITEMS CARRY MANUFACTURERS GUARANTEE. SHIPPING AND HANDLING CHARGES ARE SEPARATE. FLORIDA RESIDENTS ADD 5% SALES TAX. PRICES SUBJECT TO CHANGE W/O NOTICE.

UPS-DEPOT 1-800-648-2334/(305)591-2640
FAX (305) 477-7830 • TELEX 910 250 1011 UPS DEPOT
8725 N.W. 18 TERR, SUITE 100, MIAMI FL 33172
ALL TRADEMARKS ARE REGISTERED WITH THEIR RESPECTIVE COMPANIES

Inquiry 6

4GL

Fourth Generation Development DataBase/Applications Generator

Sculptor

40 Times Faster Than Other Fourth Generation Languages

Cut Your Software Development Time by Up To... **80%**

Completely portable for more than 90 combinations of machine and operating systems including MS-DOS, Unix, Xenix, VMS, OS9, QNX and more.

Test drive Sculptor on your MS-DOS system with our complete evaluation system for only \$45.00. (Includes a 5% discount coupon!)

FHL
770 JAMES STREET
SYRACUSE, NEW YORK 13203
315/474-7856 TELEX 646740
Since 1976

Inquiry 103

C See how well you can program for

Z80 or HD64180

This professional, IBM-PC based, compiler is a complete implementation of the "C" language for the Z80 or HD64180 microprocessor. Includes features such as: function prototyping, 31-character names, single precision floating point, full library source, M80-L80 and SLR Systems compatibility, etc. Hi-Tech™ "C" has been established for years in Australia. Pricing from \$195.00. We also have Z80/HD64180 co-processor cards for IBM-PC and PC/AT. Call for full catalog of Microprocessor development tools.

Z-World
2065 Martin Av #110
Santa Clara, CA 95050
(408) 980-1678

In Germany: iSystem Tel: 08131/1687

Inquiry 323

Advertise your computer products through

BYTE BITS
(2" x 3" ads)

For more information call Dan Harper at 603-924-6830

BYTE
70 Main St.
Peterborough, NH 03458

Inquiry 351

Quelo 68000 Software Development Tools

First release 1983 - MOTOROLA compatible - produces ROMable code, S-records, extended TEK hex, UNIX COFF. Portable SOURCE CODE. Native and cross versions on: ATARI ST, AMIGA, Masscomp, Sun, Apollo, Charles River, VAX VMS and UNIX.

68020 Cross Assembler Package
Supports 68000, 68010, 68020, 68021, 68021 and 68021
For CP/M 800 and MS/PC-DOS - \$750

68000/68010 Cross Assembler Package
For CP/M 800, 808, 808 and MS/PC-DOS - \$395

68000 "C" Cross Compiler
For MS/PC-DOS by Lattice, Inc. - \$500

N	68020 Disassembler	N
E	Supports 68000, 68010, 68020, 68021, 68021	E
W	For CP/M 800 and MS/PC-DOS - \$495/295	W
I	Amiga and Atari ST - \$1187/9; CRDS UNIX - \$995/985	I
T		T
E	68000/68010 Software Simulator	E
M	For MS/PC-DOS by Big Bang Software, Inc. - \$265, VAX - \$1800	M
S		S

Call Patrick Adams today:
Quelo, Inc.
2464 33rd West, Suite #173
Seattle, WA USA 98199
Phone 206/285-2528
COD, Visa, MasterCard
Telex: 910-333-8171

TM: Quelo, Inc. MS: Microsoft Corporation. CP/M: Digital Research

Inquiry 247

9-TRACK MAG. TAPE SUBSYSTEM FOR THE IBM PC/XT/AT AND...



For information interchange, backup and archival storage, IBEX offers a 9-track, IBM format-compatible 1/2" magnetic tape subsystem for the IBM PC, featuring:

- IBM format 1600/3200 and 800 cpl.
- Software for PC-DOS, MS-DOS.
- Also for DEC, VAX, VME, S-100, RS-232, IEEE 488.

IBEX
IBEX COMPUTER CORP
20741 Marilla St
Chattworth, CA 91311
(818) 708-8100
TWX: 910-493-2071

Write, phone or TWX for information.

Inquiry 128

BUILD A SYSTEM FOR LESS THAN \$500!

XT COMPATIBLE

\$499¹⁵!

- ★ 360K FLOPPY DISK DRIVE AND CONTROLLER
- ★ MONOCHROME MONITOR AND GRAPHICS ADAPTOR
- ★ XT STYLE KEYBOARD
- ★ PARALLEL PRINTER PORT
- ★ COMPLETE INSTRUCTIONS

OVER 10,000 SOLD!



ORDER THE FOLLOWING:

XT COMPATIBLE MOTHERBOARD, 256K OF RAM, 135 WATT POWER SUPPLY, XT STYLE FLIP-TOP CASE, MCT-5150 XT STYLE KEYBOARD, 1/2 HEIGHT 360K 5 1/4" FLOPPY DRIVE AND CONTROLLER, HYUNDAI MONOCHROME MONITOR AND GRAPHICS ADAPTOR.

WHY BUY A SYSTEM FROM JDR?

- ★ BUILD IT YOURSELF AND SAVE!
- ★ QUALITY COMPONENTS AND COMPETITIVE PRICES
- ★ ANYONE CAN ASSEMBLE A SYSTEM IN 2 HOURS USING A SCREWDRIVER AND OUR EASY-TO-FOLLOW INSTRUCTIONS
- ★ TOLL FREE TECHNICAL SUPPORT IN THE U.S. OR CANADA
- ★ MONEY BACK GUARANTEE (ASK FOR DETAILS)

I am very pleased with the computer system I purchased from you and all the outstanding support and courteous people on your staff. Your company's attitude and commitment to customer satisfaction is exceptional and makes it a pleasure to participate in mail order purchases. YOUR ATTITUDE SHOULD BE INDUSTRY STANDARD!

Daryl Hammond

AT COMPATIBLE

\$1046¹⁵!

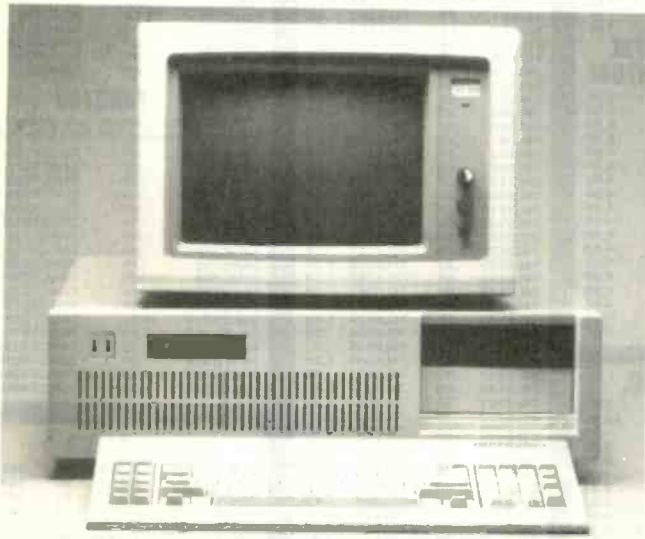

- ★ 1.2M FLOPPY DISK DRIVE & FLOPPY/HARD CONTROLLER
- ★ MONOCHROME MONITOR AND GRAPHICS ADAPTOR
- ★ AT STYLE KEYBOARD
- ★ PARALLEL PRINTER PORT
- ★ COMPLETE INSTRUCTIONS

ORDER THE FOLLOWING:

6/8 M.Hz AT COMPATIBLE MOTHERBOARD, 256K OF RAM, 220 WATT POWER SUPPLY, AT STYLE SLIDE TYPE CASE, MCT-5060 AT STYLE KEYBOARD, 1/2 HEIGHT 1.2MB 5 1/4" FLOPPY DRIVE AND FLOPPY/HARD CONTROLLER, HYUNDAI MONOCHROME MONITOR & GRAPHICS CARD.

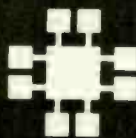

Visit our retail store located at 1256 S. Bascom Ave. in San Jose, (408) 947-8881

JDR Microdevices

110 Knowles Drive, Los Gatos, CA 95030

Toll Free 800-538-5000 • (408) 866-6200

FAX (408) 378-8927 • Telex 171-110

COPYRIGHT 1987 JDR MICRODEVICES

PLEASE USE YOUR CUSTOMER NUMBER WHEN ORDERING
TERMS: Minimum order \$10.00. For shipping and handling include \$2.50 for UPS Ground and \$3.50 for UPS Air. Orders over 1 lb. and foreign orders may require additional shipping charges—please contact our sales department for the amount. CA residents must include applicable sales tax. All merchandise is warranted for 90 days unless otherwise stated. Prices are subject to change without notice. We are not responsible for typographical errors. We reserve the right to limit quantities and to substitute manufacturer. All merchandise subject to prior sale. A full copy of our terms is available upon request. Items pictured may only be representative.

THE JDR MICRODEVICES LOGO IS A REGISTERED TRADEMARK OF JDR MICRODEVICES. JDR INSTRUMENTS AND JDR MICRODEVICES ARE TRADEMARKS OF JDR MICRODEVICES. IBM IS A TRADEMARK OF INTERNATIONAL BUSINESS MACHINES CORPORATION.

20 MEG HARD DISK DRIVE ON A CARD

\$349!

STATIC RAMS / DYNAMIC RAMS

2101	256x4	(450ns)	1.95
2102L-4	1024x1	(450ns)(LowPower)	.99
2112	256x4	(450ns)	2.99
2114	1024x4	(450ns)	.99
2114L-4	1024x4	(450ns)(LP)	1.09
2114L-2	1024x4	(150ns)(LP)	1.49
2114L-15	1024x4	(150ns)(LP)	1.95
TMS4044	4096x1	(450ns)	1.95
TMM2016-150	2048x8	(150ns)	1.49
TMM2016-100	2048x8	(100ns)	1.95
HM6116-4	2048x8	(200ns)(CMOS)	1.79
HM6116-3	2048x8	(150ns)(CMOS)	1.85
HM6116LP-4	2048x8	(200ns)(CMOS)(LP)	1.85
HM6116LP-3	2048x8	(150ns)(CMOS)(LP)	1.90
HM6116LP-2	2048x8	(120ns)(CMOS)(LP)	2.45
HM6264P-15	8192x8	(150ns)(CMOS)	3.89
HM6264LP-15	8192x8	(150ns)(CMOS)(LP)	3.95
HM6264LP-12	8192x8	(120ns)(CMOS)(LP)	4.49
HM43256LP-15	32768x8	(150ns)(CMOS)(LP)	12.95
HM43256LP-12	32768x8	(120ns)(CMOS)(LP)	14.95
HM43256LP-10	32768x8	(100ns)(CMOS)(LP)	19.95
4116-250	16384x1	(250ns)	.49
4116-200	16384x1	(200ns)	.89
4116-150	16384x1	(150ns)	.99
4116-120	16384x1	(120ns)	1.49
MK4332	32768x1	(200ns)	6.95
4164-150	65536x1	(150ns)	1.29
4164-120	65536x1	(120ns)	1.55
MCM6665	65536x1	(200ns)	1.35
TMS4164	65536x1	(150ns)	1.95
4164-REFRESH	65536x1	(150ns)(PIN 1 REFRESH)	2.95
TMS4416	16384x4	(150ns)	3.75
41128-150	131072x1	(150ns)	5.95
TMS4464-15	65536x4	(150ns)	4.95
41256-150	262144x1	(150ns)	2.95
41256-120	262144x1	(120ns)	3.95
41256-100	262144x1	(100ns)	4.95
HMS1258-100	262144x1	(100ns)(CMOS)	6.95
1 MB-120	1048576x1	(120ns)	19.95
1 MB-100	1048576x1	(100ns)	24.95

★★★★ HIGH-TECH ★★★★★

80387 \$495.00

- ★ 16 MEGAHERTZ MATH CO-PROCESSOR IN A PIN GRID ARRAY
- ★ FOR INTEL INBOARD AND OTHER 80386 BASED COMPUTERS
- ★ GET ALL THE SPEED AND POWER YOUR MACHINE CAN DELIVER
- ★ GREAT ADDITION FOR CAD, SPREADSHEET AND OTHER POWER PROGRAMS

★★★★ SPOTLIGHT ★★★★★

U.S. AND CANADA ORDER TOLL FREE 800-538-5000

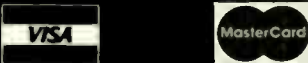

EPROMS

2708	1024x8	(450ns)	4.95
2716	2048x8	(450ns)(5V)	3.49
2716-1	2048x8	(350ns)(5V)	3.95
TMS2532	4096x8	(450ns)(5V)	5.95
2732	4096x8	(450ns)(5V)	3.95
2732A	4096x8	(250ns)(5V)(21V PGM)	3.95
2732A-2	4096x8	(200ns)(5V)(21V PGM)	4.25
2764	2048x16	(250ns)(5V)(CMOS)	4.95
2764	8192x8	(450ns)(5V)	3.49
2764-250	8192x8	(250ns)(5V)	3.69
2764-200	8192x8	(200ns)(5V)	4.25
MCM68766	8192x8	(350ns)(5V)(24 Pin)	15.95
27128	16384x8	(250ns)(5V)	4.25
27C256	32768x8	(250ns)(5V)(CMOS)	7.95
27C256	32768x8	(250ns)(5V)	5.95
27C512	65536x8	(250ns)(5V)	11.95
27C512	65536x8	(250ns)(5V)(CMOS)	12.95

SPECTRONICS CORPORATION EPROM ERASERS



Model	Timer	Capacity Chip	Intensity (uW/Cm ²)	Unit Price
PE-14T	NO	9	8,000	\$83.00
PE-14T	YES	9	8,000	\$119.00
PE-24T	YES	12	9,600	\$175.00

8000

8035	1.49
8039	1.95
8052AH BASIC	34.95
8080	2.95
8085	2.49
8087 5MHz	129.00
8087-2 8MHz	169.95
8088	6.95
8088-2	9.95
8155	2.49
8748	7.95
8755	14.95
80286	129.95
80287 6MHz	199.95
80287-8 8MHz	299.95
80287-10 10MHz	399.95

V 20 SERIES

V20 ⁺ 5 MHz	8.95
V20 ⁺ 8 MHz	10.95
V20 8 MHz	13.95

*Replaces 8088 to speed up your PC by 10 to 40%

CRT CONTROLLERS

6845	4.95
68B45	8.95
6847	11.95
HD46505SP	6.95
MC1372	2.95
8275	26.95
7220	19.95
CRT5027	12.95
CRT5037	9.95
TMS9918A	19.95

8200

8205	3.29
8212	1.49
8216	1.49
8224	2.25
8237	4.95
8237-5	5.49
8250	6.95
8251	1.69
8251A	1.89
8253	1.89
8253-5	1.95
8255	1.69
8255-5	1.89
8259	1.95
8259-5	2.29
8272	4.95
8279	2.49
8279-5	2.95
8282	3.95
8284	2.95
8286	3.95
8288	4.95

DISK CONTROLLERS

1771	4.95
1791	9.95
1793	9.95
1795	12.95
1797	12.95
2791	19.95
2793	19.95
2797	29.95
8272	4.95
UPD765	4.95
MB8876	12.95
MB8877	12.95
1691	6.95
2143	6.95
9216	7.95

Z-80

Z80-CPU 2.5 MHz	1.69
4.0 MHz	
Z80A-CPU	1.79
Z80A-CTC	1.89
Z80A-DART	5.95
Z80A-DMA	5.95
Z80A-PIO	1.89
Z80A-SIO 0	5.95
Z80A-SIO 1	5.95
Z80A-SIO 2	5.95

BIT RATE GENERATORS

MC14411	9.95
BR1941	4.95
4702	9.95
COM8116	8.95

6.0 MHz

Z80B-CPU	3.75
Z80B-CTC	4.25
Z80B-PIO	4.25
Z80B-DART	14.95
Z80B-SIO 0	12.95
Z80B-SIO 2	12.95
Z8671 ZIO/2	19.95

UARTS

AY5-1013	3.95
AY3-1015	4.95
TR1022	3.95
2651	4.95
IM6402	6.95
IM6403	9.95
INS8250	6.95
NS16450	15.95

6500

1.0 MHz	
32768 KHz	9.95
1.0 MHz	2.95
1.8432	2.95
2.0	1.95
2.097152	1.95
2.4576	1.95
3.2768	1.95
3.279545	1.95
4.0	1.95
4.032	1.95
5.0	1.95
5.0688	1.95
6.0	1.95
6.144	1.95
6.5536	1.95
8.0	1.95
10.0	1.95
10.738635	1.95
12.0	1.95
14.31818	1.95
15.0	1.95
16.0	1.95
17.4430	1.95
18.0	1.95
18.432	1.95
20.0	1.95
22.1184	1.95
24.0	1.95
32.0	1.95

2.0 MHz	
8502A	2.95
6520A	2.95
6522A	5.95
6532A	11.95
6545A	7.95
8551A	6.95

3.0 MHz

6502B	6.95
-------	------

CRYSTALS

CRYSTAL OSCILLATORS	
1.0MHz	
1.8432	5.95
2.0	5.95
2.4576	5.95
2.0	4.95
4.0	4.95
5.0688	4.95
6.0	4.95
6.144	4.95
8.0	4.95
8.0	4.95
12.0	4.95
12.480	4.95
15.0	4.95
16.0	4.95
18.432	4.95
20.0	4.95
24.0	4.95

2.0 MHz	
68800	4.95
68802	5.95
68809E	6.95
68809	6.95
68821	3.95
68845	6.95
68850	2.95
68854	7.95

MISC.

MAX232	7.95
TMS99532	19.95
ULN2003	.79
3242	7.95
3341	4.95
MC3470	1.95
MC3480	8.95
MC3487	2.95
11C90	19.95
2513-001 UP	6.95
AY5-2376	11.95
AY5-3600 PRO	11.95

74LS00

74LS00	.16
74LS01	.18
74LS02	.17
74LS03	.18
74LS04	.16
74LS05	.18
74LS08	.18
74LS09	.18
74LS10	.16
74LS11	.22
74LS12	.22
74LS13	.26
74LS14	.39
74LS15	.26
74LS20	.17
74LS21	.22
74LS22	.23
74LS23	.23
74LS28	.26
74LS30	.17
74LS32	.18
74LS33	.28
74LS37	.26
74LS38	.26
74LS39	.39
74LS47	.75
74LS48	.85
74LS51	.17
74LS73	.29
74LS74	.24
74LS75	.29
74LS76	.29
74LS86	.49
74LS85	.49
74LS86	.22
74LS90	.39
74LS92	.49
74LS93	.39
74LS95	.49
74LS107	.39
74LS109	.36
74LS112	.29
74LS122	.45
74LS123	.49
74LS124	2.75
74LS125	.39
74LS126	.39
74LS132	.49
74LS136	.39
74LS138	.39
74LS148	.99
74LS151	.39
74LS153	.39
74LS154	1.49
74LS155	.59
74LS156	.49
74LS157	.35
74LS158	.39
74LS160	.29
74LS161	.39
74LS162	.49
74LS163	.39
74LS164	.49

74LS00

74LS165	.65
74LS166	.95
74LS169	.95
74LS173	.39
74LS174	.49
74LS175	.39
74LS191	.49
74LS192	.69
74LS193	.69
74LS194	.69
74LS195	.69
74LS196	.59
74LS197	.59
74LS211	.59
74LS241	.69
74LS242	.69
74LS243	.69
74LS244	.69
74LS245	.79
74LS251	.49
74LS253	1.79
74LS256	1.79
74LS257	.69
74LS258	.69
74LS259	1.29
74LS260	.49
74LS266	.39
74LS273	.79
74LS279	.39
74LS280	1.98
74LS283	.59
74LS289	.89
74LS293	.89
74LS299	1.49
74LS322	3.95
74LS323	2.49
74LS364	1.95
74LS365	.39
74LS367	.39
74LS368	.39
74LS373	.79
74LS374	.79
74LS375	.95
74LS377	.79
74LS378	1.18
74LS390	1.19
74LS393	.79
74LS541	1.49
74LS544	1.95
74LS640	.99
74LS645	.99
74LS669	1.29
74LS670	.99
74LS682	3.20
74LS683	3.20
74LS684	3.20
74LS688	2.40
74LS783	22.95
31LS95	1.49
31LS96	1.49
31LS97	1.49
31LS98	1.49
25LS251	2.80
25LS252	2.80
26LS31	1.95
26LS32	1.95

HIGH SPEED CMOS

EGA CARD AND MONITOR NOW \$499!

CMOS

4001	.19	14419	4.95
4011	.19	14433	14.95
4012	.25	14497	6.95
4013	.35	4503	.49
4015	.29	4511	.69
4016	.29	4516	.79
4017	.49	4518	.85
4018	.69	4522	.79
4020	.59	4526	.79
4021	.69	4527	1.95
4024	.49	4528	.79
4025	.25	4529	2.95
4027	.39	4532	1.95
4028	.65	4538	.95
4035	.69	4541	1.23
4040	.69	4553	5.79
4041	.75	4585	.75
4042	.59	4702	12.95
4043	.85	74C00	.29
4044	.69	74C14	.59
4045	1.98	74C74	.59
4046	.69	74C83	1.95
4047	.69	74C85	1.49
4049	.29	74C95	.99
4050	.29	74C150	5.75
4051	.69	74C151	2.25
4052	.69	74C161	.99
4053	.69	74C163	.99
4056	2.19	74C164	1.39
4060	.69	74C192	1.49
4066	.29	74C193	1.49
4069	.19	74C221	2.49
4076	.59	74C240	1.89
4077	.29	74C244	1.89
4081	.22	74C374	1.99
4085	.79	74C905	10.95
4086	.89	74C911	8.95
4093	.49	74C917	12.95
4094	2.49	74C922	4.49
14411	9.95	74C923	4.95
14412	6.95	74C926	7.95

7400/8000

7400	.19	74147	2.49
7402	.19	74148	1.20
7404	.29	74150	1.35
7406	.29	74151	.55
7407	.29	74153	.55
7408	.24	74154	1.49
7410	.19	74155	.75
7411	.25	74157	.55
7414	.49	74159	1.65
7416	.25	74161	.69
7417	.25	74161	.69
7420	.19	74164	.95
7423	.29	74165	.85
7430	.19	74166	1.00
7432	.29	74175	.89
7433	.29	74177	.75
7442	.49	74178	1.15
7445	.69	74181	2.25
7447	.89	74182	.75
7470	.35	74184	2.00
7473	.34	74191	1.15
7474	.33	74192	.79
7475	.45	74194	.85
7476	.35	74196	.79
7483	.50	74197	.79
7485	.59	74199	1.35
7486	.29	74221	1.35
7489	2.15	74246	.95
7490	.39	74247	1.25
7492	.50	74248	1.85
7493	.35	74249	1.95
7495	.55	74251	.75
7497	2.75	74265	1.35
74100	2.29	74273	1.95
74121	.29	74278	3.11
74123	.49	74367	.65
74125	.45	74368	.65
74141	.65	9368	3.95
74143	5.95	9602	1.50
74144	2.95	9637	2.95
74145	.60	96S02	1.95

74800

74500	.29	74S163	1.29
74502	.29	74S168	3.95
74503	.29	74S174	.79
74504	.29	74S175	.79
74505	.29	74S188	1.95
74508	.35	74S189	1.95
74510	.29	74S195	1.49
74515	.49	74S196	2.49
74530	.29	74S197	2.95
74532	.35	74S226	3.99
74537	.69	74S240	1.49
74538	.49	74S241	1.49
74574	.49	74S244	1.49
74585	.95	74S257	.79
74586	.35	74S253	.79
74S112	.50	74S258	.95
74S124	2.75	74S280	1.95
74S138	.79	74S287	1.69
74S140	.55	74S288	1.69
74S151	.79	74S299	2.99
74S153	.79	74S373	1.69
74S157	.79	74S374	1.69
74S158	.95	74S471	4.95
74S161	1.29	74S571	2.95

VOLTAGE REGULATORS

TO-220 CASE

7805T	.49	790ET	.59
7808T	.49	790ET	.59
7812T	.49	7912T	.59
7815T	.49	7915T	.59

TO-3 CASE

7805K	1.59	790K	1.69
7812K	1.39	7912K	1.49

TO-93 CASE

78L05	.49	79L05	.69
78L12	.49	79L12	1.49

OTHER VOLTAGE REGS

LM323K	5V 3A	TO-3	4.79
LM338K	Adj. 5A	TO-3	6.95

LINEAR

TL066	.99	LM733	.98	
TL071	.69	LM741	.29	
TL072	1.09	LM747	.69	
TL074	1.95	LM748	.59	
TL081	.59	MC1330	1.89	
TL082	.99	MC1350	1.19	
TL084	1.49	MC1372	6.95	
LM301	.34	LM1414	1.59	
LM309K	1.25	LM1458	.49	
LM311	.59	LM1488	.49	
LM311H	.89	LM1489	.49	
LM317K	3.49	LM1496	.85	
LM317T	.95	LM1812	8.25	
LM318	1.49	LM1889	1.95	
LM319	1.25	ULN2003	.79	
LM320	***	7900	XR2206	3.95
LM322	1.95	XR2211	2.95	
LM323K	4.79	XR2240	1.95	
LM324	.49	MPQ2907	1.95	
LM331	3.95	LM2917	1.95	
LM334	1.19	CA3046	.89	
LM335	1.79	CA3081	.99	
LM336	1.39	CA3082	.99	
LM337K	3.95	CA3086	8.80	
LM338K	6.95	CA3130E	.99	
LM339	.59	CA3146	1.29	
LM340	***	7800	CA3160	1.19
LM350T	4.60	MC3373	1.29	
LF353	.59	MC3470	1.95	
LF356	.99	MC3480	8.95	
LF357	.99	MC3487	2.95	
LM358	.59	LM3500	.49	
LM380	.89	LM3909	.98	
LM383	1.95	LM3911	2.25	
LM386	.89	LM3914	2.39	
LM393	.45	MC4024	3.49	
LM394H	5.95	MC4044	3.99	
TL494	4.20	RC4136	1.25	
TL497	3.25	RC4558	.69	
NE555	.29	LM13600	1.49	
NE556	.49	75107	1.49	
NE558	1.29	75110	1.95	
NE564	1.95	75150	1.95	
LM565	.95	75154	1.95	
LM566	1.49	75188	1.25	
LM567	.79	75189	1.25	
NE570	2.95	75451	3.99	
NE590	2.50	75452	.39	
NE592	.98	75453	.39	
LM710	.75	75477	1.29	
LM723	.49	75492	.79	
M-TO-5 CAN.	K-TO-3 T.	T-TO-220		

EDGE CARD CONNECTORS

100 PIN ST	S-100	.125	3.95
100 PIN WW	S-100	.125	4.95
62 PIN ST	IBM PC	.100	1.95
50 PIN ST	APPLE	.100	2.95
44 PIN ST	STD	.156	1.95
44 PIN WW	STD	.156	4.95

36 PIN CENTRONICS

ICDN36	RIBBON CABLE	6.95
CEN36	SOLDER CUP	4.95
ICDN35/F	RIBBON CABLE	7.95
CEN36/C	RT ANGLE PC MOUNT	4.95

INTERSIL

ICL7106	9.95
ICL7107	12.95
ICL7660	2.95
ICL8038	4.95
ICM7207A	5.95
ICM7208	15.95

IC SOCKETS

8 PIN ST	1.99	100+
14 PIN ST	.11	.10
16 PIN ST	.12	.10
18 PIN ST	.1E	.13
20 PIN ST	.1E	.15
22 PIN ST	.1E	.12
24 PIN ST	.2C	.15
28 PIN ST	.22	.16
40 PIN ST	.3C	.22
64 PIN ST	1.9E	1.49

ST-SOLDERTAIL

8 PIN WW	.5E	.69
14 PIN WW	.6E	.52
16 PIN WW	.6E	.58
18 PIN WW	.9E	.90
20 PIN WW	1.0E	.98
22 PIN WW	1.3E	1.28
24 PIN WW	1.4E	1.35
28 PIN WW	1.6E	1.49
40 PIN WW	1.9E	1.80

WW-WIREWRAP

16 PIN ZIF	4.9E	CALL
24 PIN ZIF	5.9E	CALL
28 PIN ZIF	6.9E	CALL
40 PIN ZIF	9.9E	CALL

ZIF-TEXTOL

(ZERO INSERTION FORCE)

DIP CONNECTORS

DESCRIPTION	ORDER BY	CONTACTS								
		8	14	16	18	20	22	24	28	40
HIGH RELIABILITY TOOLED ST IC SOCKETS	AUGATxxST	.62	.79	.89	1.09	1.29	1.39	1.49	1.69	2.49
HIGH RELIABILITY TOOLED WW IC SOCKETS	AUGATxxWW	1.30	1.80	2.10	2.40	2.50	2.90	3.15	3.70	5.40
COMPONENT CARRIES (DIP HEADERS)	ICCxx	.49	.59	.89	.99	.99	.99	.99	1.09	1.49
RIBBON CABLE DIP PLUGS (IDC)	IDPxx	---	.95	.95	---	---	---	---	1.75	2.95

DATA ACQ INTERFACE

ADC0800	15.55	8T26	1.29
ADC0804	3.49	8T28	1.29
ADC0809	4.49	8T95	.89
ADC0816	14.95	8T96	.89
ADC0817	9.95	8T97	.59
ADC0831	8.95	8T98	.89
DAC0800	4.49	DM8131	2.95
DAC0806	1.95	DP8304	2.25
DAC0808	2.95	DS833	2.25
DAC1020	8.25	DS8835	1.99
DAC1022	5.95	DS8836	.99
MC1408L	2.95	DS8837	1.65

DIODES/OPTO/TRANSISTORS

1N751	.25	4N26	.69
1N759	.25	4N27	.69
1N4148	25/1.00	4N28	.69
1N4004	10/1.00	4N32	1.19
1N5402	.25	4N37	.69
KBPO2	.55	MCT-2	.59
KBUBA	.95	MCT-6	1.29
MDA990-2	.35	TIL-111	2.25
N2222	.25	2N3906	10.10
PN2222	.10	2N4401	.25
2N2906	.50	2N4402	.25
2N2907	.25	2N4403	.25
2N3055	.79	2N6045	1.75
2N3904	.10	TIP-31	.49

D-SUBMINIATURE

DESCRIPTION	ORDER BY	CONTACTS						
		9	15	19	25	37	50	
SOLDER CUP	MALE	DBxxP	.82	.90	1.25	1.25	1.80	3.48
	FEMALE	DBxxS	.95	1.15	1.50	1.50	2.35	4.32
RIGHT ANGLE PC SOLDER	MALE	DBxxPR	1.20	1.49	---	1.95	2.65	---
	FEMALE	DBxxSR	1.25	1.55	---	2.00	2.79	---
WIRE WRAP	MALE	DBxxPWW	1.69	2.58	---	3.89	5.60	---
	FEMALE	DBxxSww	2.76	4.27	---	6.84	9.95	---
IDC RIBBON CABLE	MALE	IDBxxP	2.70	2.95	---	3.98	5.70	---
	FEMALE	IDBxxS	2.92	3.20	---	4.33	6.76	---
HOODS	METAL	MHOODxx	1.25	1.25	1.30	1.30	---	---
	GREY	HOODxx	.65	.65	---	.65	.75	.95

MOUNTING HARDWARE \$1.00

MTG HDWR	ICD37P
HOOD25	IDB37P
HOOD37S	IDB37P
HOOD50	IDB50

LED DISPLAYS

FND-357(359)	COM CATHODE	362"	1.25
FND-500(503)	COM CATHODE	5"	1.49
FND-507(510)	COM ANODE	5"	1.49
MAN-72	COM ANODE	3"	.99
MAN-74	COM CATHODE	3"	.99
TIL-313	COM CATHODE	3"	.45
TIL-311	4x7 HEX W/ LOGIC	.270"	9.95

IDC CONNECTORS

DESCRIPTION	ORDER BY	CONTACTS					
		10	20	26	34	40	50
SOLDER HEADER	IDHxxS	.82	1.29	1.68	2.20	2.58	3.24
RIGHT ANGLE SOLDER HEADER	IDHxxSR	.85	1.35	1.76	2.31	2.72	3.39
WW HEADER	IDHxxW	1.86	2.98	3.84	4.50	5.28	6.85
RIGHT ANGLE WW HEADER	IDHxxWR	2.05	3.28	4.22	4.45	4.80	7.30
RIBBON HEADER SOCKET	IDSxx	.79	.99	1.39	1.59	1.99	2.25
RIBBON HEADER	IDMxx	---	5.50	6.25	7.00	7.50	8.50
RIBBON EDGE CARD	IDExx	1.75	2.25	2.65	2.75	3.80	

MODEM 1200 BAUD \$79.95

FOR IBM WITH SOFTWARE

MODEM 2400 BAUD \$179.95

BARGAIN HUNTERS CORNER

HYUNDAI MONOCHROME MONITOR

- ★ 12" NON-GLARE AMBER SCREEN
- ★ IBM COMPATIBLE TTL INPUT
- ★ ATTRACTIVE CASE WITH TILT & SWIVEL BASE

ONLY \$69.95

SPECIAL ENDS 10/31/87

PAGE WIRE WRAP WIRE PRECUT ASSORTMENT IN ASSORTED COLORS \$27.50

100ea: 5.5", 6.0", 6.5", 7.0"
250ea: 2.5", 4.5", 5.0"
500ea: 3.0", 3.5", 4.0"

SPOOLS
100 feet \$4.30 250 feet \$7.25
500 feet \$13.25 1000 feet \$21.95

Please specify color:
Blue, Black, Yellow or Red

WIRE WRAP PROTOTYPE CARDS FR-4 EPOXY GLASS LAMINATE WITH GOLD-PLATED EDGE-CARD FINGERS



XT
BOTH CARDS HAVE SILK SCREENED LEGENDS AND INCLUDES MOUNTING BRACKET

IBM-PR1 WITH +5V AND GROUND PLANE \$27.95
IBM-PR2 AS ABOVE W/DECODING LAYOUT \$29.95

EXTENDER CARDS

IBM-PC \$29.95
IBM-AT \$39.95



AT

IBM-PRAT LARGE +5V & GROUND PLANES \$29.95

S-100
P100-1 BARE - NO FOIL PADS \$15.15
P100-2 HORIZONTAL BUS \$21.80
P100-3 VERTICAL BUS \$21.80
P100-4 SINGLE FOIL PADS PER HOLE \$22.75

APPLE
P500-1 BARE - NO FOIL PADS \$15.15
P500-3 HORIZONTAL BUS \$22.75
P500-4 SINGLE FOIL PADS PER HOLE \$21.80
7060-45 FOR APPLE II₆ AUX SLOT \$30.00

SOCKET-WRAP I.D.™

- SLIPS OVER WIRE WRAP PINS
- IDENTIFIES PIN NUMBERS ON WRAP SIDE OF BOARD
- CAN WRITE ON PLASTIC, SUCH AS IC #

PINS	PART #	PCK. OF	PRICE
8	IDWRAP 08	10	1.95
14	IDWRAP 14	10	1.95
16	IDWRAP 16	10	1.95
18	IDWRAP 18	5	1.95
20	IDWRAP 20	5	1.95
22	IDWRAP 22	5	1.95
24	IDWRAP 24	5	1.95
28	IDWRAP 28	5	1.95
40	IDWRAP 40	5	1.95

PLEASE ORDER BY NUMBER OF PACKAGES (PCK. OF)

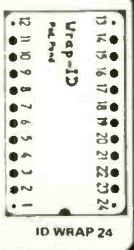

FRAME STYLE TRANSFORMERS

12.6V AC CT	2 AMP	5.95
12.6V AC CT	4 AMP	7.95
12.6V AC CT	8 AMP	10.95
25.2V AC CT	2 AMP	7.95

25 PIN D-SUB BENDER CHANGERS \$7.95

CAPACITORS

TANTALUM

1.0µf	15V	.35	47µf	35V	.45
6.8	15V	.70	1.0	35V	.45
10	15V	.80	2.2	35V	.65
22	15V	1.35	4.7	35V	.85
.22	35V	.40	10	35V	1.00

DISC

10µf	50V	.05	680	50V	.05
22	50V	.05	.001µf	50V	.05
27	50V	.05	.002	50V	.05
33	50V	.05	.005	50V	.05
47	50V	.05	.01	50V	.07
68	50V	.05	.02	50V	.07
100	50V	.05	.05	50V	.07
220	50V	.05	.1	12V	.10
560	50V	.05	.1	50V	.12

MONOLITHIC

.01µf	50V	.14	.1µf	50V	.18
.047µf	50V	.15	.47µf	50V	.25

ELECTROLYTIC

RADIAL		AXIAL			
1µf	25V	.14	1µf	50V	.14
2.2	35V	.15	10	50V	.16
4.7	50V	.15	22	16V	.14
10	50V	.15	47	50V	.20
47	35V	.18	100	35V	.25
100	46V	.18	220	25V	.30
220	35V	.20	470	50V	.50
470	25V	.30	1000	16V	.60
2200	16V	.70	2200	16V	.70
4700	25V	1.45	4700	16V	1.25

DATARASE EPROM ERASER \$34.95

- ERASES 2 IN 10 MINUTES
- COMPACT-NO DRAWER
- THIN METAL SHUTTER PREVENTS UV LIGHT FROM ESCAPING

1/4 WATT RESISTORS

5% CARBON FILM ALL STANDARD VALUES FROM 1 OHM TO 10 MEG. OHM

10 PCS	same value	.05	100 PCS	same value	.02
50 PCS	same value	.025	1000 PCS	same value	.015

RESISTOR NETWORKS

SIP	10 PIN	9 RESISTOR	.69
SIP	8 PIN	7 RESISTOR	.59
DIP	16 PIN	8 RESISTOR	1.09
DIP	16 PIN	15 RESISTOR	1.09
DIP	14 PIN	7 RESISTOR	.99
DIP	14 PIN	13 RESISTOR	.99

SPECIALS ON BYPASS CAPACITORS

.01 µf CERAMIC DISC	100/\$5.00
.01 µf MONOLITHIC	100/\$10.00
.1 µf CERAMIC DISC	100/\$6.50
.1 µf MONOLITHIC	100/\$12.50

WISH SOLDERLESS BREADBOARDS

PART NUMBER	DIMENSIONS	DISTRIBUTION STRIPS)	TIE POINTS	TERMINAL STRIPS)	TIE POINTS	BINDING POSTS	PRICE
WBU-D	.38 x 6.50"	1	100	---	---	---	2.95
WBU-T	1.38 x 6.50"	---	---	1	630	---	6.95
WBU-204-3	3.94 x 8.45"	1	100	2	1260	2	17.95
WBU-204	5.13 x 8.45"	4	400	2	1260	3	24.95
WBU-206	6.88 x 9.06"	5	500	3	1890	4	29.95
WBU-208	8.25 x 9.45"	7	700	4	2520	4	39.95

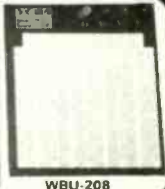

LITHIUM BATTERY AS USED IN CLOCK CIRCUITS

3 VOLT BATTERY \$3.95
BATTERY HOLDER \$1.49

MUFFIN FANS

3.15" SQ 14.95 3.63" SQ 14.95
3.18" SQUARE 16.95

6' LINE CORDS

2 conductor .39 3 conductor .99
3 conductor w/female socket 1.49

EMI FILTER \$4.95

2 VOLUME SET IC MASTER

THE INDUSTRY STANDARD

\$129.95

NEW STORE HOURS! M-F: 9-7, SAT: 9-5 & SUN: 12-4

Visit our retail store located at 1256 S. Bascom Ave. in San Jose, (408) 947-8881

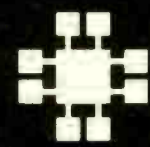

JDR Microdevices
110 Knowles Drive, Los Gatos, CA 95030
Toll Free 800-538-5000 • (408) 866-6200
FAX (408) 378-8927 • Telex 171-110

PLEASE USE YOUR CUSTOMER NUMBER WHEN ORDERING

TERMS: Minimum order \$10.00. For shipping and handling include \$2.50 for UPS Ground and \$3.50 for UPS Air. Orders over 1 lb. and foreign orders may require additional shipping charges—please contact our sales department for the amount. CA. residents must include applicable sales tax. All merchandise is warranted for 90 days unless otherwise stated. Prices are subject to change without notice. We are not responsible for typographical errors. We reserve the right to limit quantities and to substitute manufacturer. All merchandise subject to prior sale. A full copy of our terms is available upon request. Items pictured may only be representative.

COPYRIGHT 1987 JDR MICRODEVICES

THE JDR MICRODEVICES LOGO IS A REGISTERED TRADEMARK OF JDR MICRODEVICES. JDR INSTRUMENTS AND JDR MICRODEVICES ARE TRADEMARKS OF JDR MICRODEVICES. IBM IS A TRADEMARK OF INTERNATIONAL BUSINESS MACHINES CORPORATION. APPLE IS A TRADEMARK OF APPLE COMPUTER.

EGA CARD AND MONITOR NOW \$499!

MONITOR STANDS

MODEL MS-100 \$12.95
 • TILTS AND SWIVELS
 • STURDY ABS PLASTIC CONSTRUCTION

MODEL MS-200 \$39.95
 • TILTS AND SWIVELS
 • BUILT-IN POWER STATION
 INDEPENDANTLY CONTROLS UP TO 5
 120 VOLT AC OUTLETS
 • BUILT-IN SURGE SUPPRESSOR
 • UL APPROVED



CRT MONITORS FOR ALL APPLICATIONS



CASPER EGA MONITOR

- EGA & CGA COMPATIBLE
- SCANNING FREQUENCIES: 15.75 / 21.95 KHz
- RES: 640 x 200 / 350
- .31mm DOT PITCH, 25 MHz
- 16 COLORS OUT OF 64
- 14" BLACK MATRIX SCREEN

\$399.95



CASPER RGB MONITOR

- COLOR: GREEN, AMBER
- SWITCH ON REAR
- DIGITAL RGB-IBM COMPATIBLE
- 14" NON-GLARE SCREEN
- RESOLUTION: 640H x 240V
- .39mm DOT PITCH
- CABLE FOR IBM PC INCLUDED

\$279.95



FORTRONICS MONOCHROME

- IBM COMPATIBLE TTL INPUT
- 12" NON-GLARE SCREEN
- VERY HIGH RESOLUTION, 1100 LINES (CENTER)
- 25 MHz BANDWIDTH
- CABLE FOR IBM PC INCLUDED
- AMBER OR GREEN AVAILABLE

\$99.95

SOLDER STATION

JDR PART #: 168-2C

- FULLY ADJUSTABLE HEAT SETTING WITH TEMP. ERRATURE READOUT
- QUICK HEATING AND RECOVERY
- VARIETY OF REPLACEMENT TIPS ARE AVAILABLE
- RANGE: 200°-900°F
- UL APPROVED

\$49.95



DISK DRIVES FOR APPLE COMPUTERS

AP-150 \$99.95

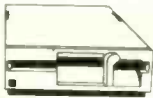

- 1/2 HT, DIRECT DRIVE
- 100% APPLE COMPATIBLE
- SIX MONTH WARRANTY

AP-135 \$129.95



- FULL HT SHUGART MECHANISM
- DIRECT REPLACEMENT FOR APPLE DISK II
- SIX MONTH WARRANTY

AD-3C \$139.95

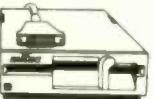

- 100% APPLE IIc COMPATIBLE, READY TO PLUG IN, W/ SHIELDED CABLE & MOLDED 19 PIN CONNECTOR
- FAST, RELIABLE SLIMLINE DIRECT DRIVE
- SIX MONTH WARRANTY

DISK DRIVE ACCESSORIES

- FDD CONTROLLER CARD \$49.95
- IIc ADAPTOR CABLE \$19.95
- ADAPTS STANDARD APPLE DRIVES FOR USE WITH APPLE IIc

APPLE COMPATIBLE INTERFACE CARDS

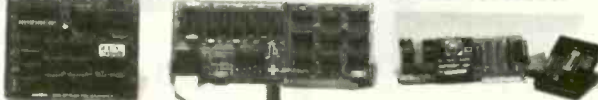

EPROM PROGRAMMER

- DUPLICATE OR BURN ANY 27xx SERIES EPROM (2716 TO 27128)
- MENU DRIVEN SOFTWARE
- HIGH SPEED WRITE ALGORITHM

RP-525 \$59.95

16K RAMCARD

- FULL 2 YEAR WARRANTY
- EXPAND YOUR 48K MACHINE TO A FULL 64K OF MEMORY
- CAN BE USED IN PLACE OF THE APPLE LANGUAGE CARD

RAM-CARD \$39.95

IC TEST CARD

- QUICKLY TESTS MANY COMMON ICs
- DISPLAYS PASS OR FAIL
- TEST 4000 & 74HC SERIES CMOS, 7400, 74LS, 74L, 74H & 74S

IC-TESTER \$129.95

20 MEGABYTE HARD DISK CARD



- SAVES SPACE AND REDUCES POWER CONSUMPTION
- IDEAL FOR PCs WITH FULL HEIGHT FLOPPIES
- LEAVES ROOM FOR A HALF LENGTH CARD IN ADJACENT SLOT

NOW \$349

MOLDED INTERFACE CABLES

6 FOOT, 100% SHIELDED, MEETS FCC



- IBM PARALLEL PRINTER CABLE CENTRONICS (MALE TO FEMALE) 15.95
- CENTRONICS (MALE TO MALE) 14.95
- MODEM CABLE (FOR IBM) 7.95
- RS232 SERIAL (MALE TO FEMALE) 9.95
- RS232 SERIAL (MALE TO MALE) 9.95
- KEYBOARD EXTENDER (COILED) 7.95
- APPLE II JOYSTICK EXTENDER 4.95

G. ITOH BITE MAN II PRINTER



- 160 CPS DRAFT, 32 CPS NLQ
- 9 x 9 DOT MATRIX
- SUPPORTS EPSON/IBM GRAPHICS
- FRICTION AND PIN FEEDS
- VARIABLE LINE SPACING AND PITCH

\$219.95

- IBM PRINTER CABLE \$9.95
- REPLACEMENT RIBBON CARTRIDGE \$7.95

SWITCH BOXES

ALL LINES SWITCHED, GOLD PLATED CONNECTORS, QUALITY SWITCHES

2 WAY \$39.95

- CONNECTS 2 PRINTERS TO 1 COMPUTER OR VICE VERSA

AB-P (CENTRONICS PARALLEL)
 AB-S (RS232 SERIAL)



3 WAY \$99.95

- CONNECTS 3 PRINTERS TO 1 COMPUTER OR VICE VERSA

SWITCH-3P (CENTRONICS PARALLEL)
 SWITCH-3S (RS232 SERIAL)



KB-1000 \$79.95

CASE WITH KEYBOARD FOR APPLE TYPE MOTHERBOARD

- USER DEFINED FUNCTION KEYS
- NUMERIC KEYPAD W/ CURSOR CONTROL
- CAPS LOCK
- AUTO-REPEAT

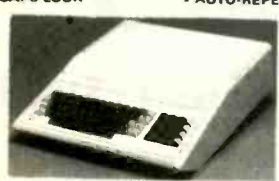

JOYSTICK GC-10 \$19.95

- SET X-Y AXIS FOR AUTO CENTER OR FREE MOVEMENT
- FIRE BUTTON FOR USE WITH GAME SOFTWARE
- ATTRACTIVE, SOLID, PLASTIC CASE
- INCLUDES ADAPTOR CABLE FOR IBM, APPLE II, IIc



POWER STRIP \$9.95

JDR PART #: POWER-STRIP

- 15 AMP CIRCUIT BREAKER
- 6 RECEPTACLES
- 6 FOOT POWER CORD
- PILOT SWITCH

WITH SURGE PROTECTION

JDR PART #: MT-080

\$12.95

NASHUA DISKETTES

NASHUA DISKETTES WERE JUDGED TO HAVE THE HIGHEST POLISH AND RECORDED AMPLITUDE OF ANY DISKETTES TESTED (COMPARING FLOPPY DISKS, BYTE 9/84)

- N-MD2D DS/DD 5 1/4" SOFT \$9.90
- N-MD2F DS/QUAD 5 1/4" SOFT \$19.95
- N-MD2H DS/HD 5 1/4" FOR AT \$24.95
- N-FD1 SS/DD 8" SOFT \$27.95
- N-FD2D OS/DD 8" SOFT \$34.95

BULK DISKETTE SALE

5 1/4" SOFT SECTOR, DS/DD W/ TYVEC SLEEVES & HUB RINGS

\$9.90 **69¢ ea** **59¢ ea**
 BOX OF 10 BULK QTY 50 BULK QTY 250

DISKETTE FILES

- 5 1/4" DISKFILE HOLDS 70 \$8.95
- 3 1/2" DISKFILE HOLDS 40 \$8.95

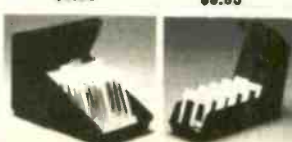

Seagate

5 1/4" HARD DISK DRIVES

- ST-225 HALF HT 20MB 65ms \$275
- ST-238 HALF HT 30MB 65ms (RL) \$299
- ST-251 HALF HT 40MB 40ms \$469
- ST-277 HALF HT 60MB 40ms (RL) \$649
- ST-4038 FULL HT 30MB 40ms \$559
- ST-4096 FULL HT 80MB 28ms \$1195

1/2 HEIGHT FLOPPY DISK DRIVES

- 5 1/4" TEAC FD-56B DS/DD \$109.95
- 5 1/4" TEAC FD-56F OS/QUAD \$124.95
- 5 1/4" TEAC FD-56GFV DS/HD \$154.95
- 5 1/4" MITSUBISHI OS/HD \$119.95
- 3 1/2" FDD KIT DS/DD \$149.95

KIT INCLUDES MOUNTING HARDWARE TO FIT 5 1/4" SLOT, AT & XT VERSIONS AVAILABLE

DISK DRIVE ACCESSORIES

- TEAC SPECIFICATION MANUAL \$5.00
- TEAC MAINTENANCE MANUAL \$25.00
- 1/2 HT MNTG HARDWARE FOR IBM \$2.95
- MOUNTING RAILS FOR IBM AT \$4.95
- "Y" POWER CABLE FOR 5 1/4" FDDs \$2.95
- 5 1/4" FDD POWER CONNECTORS \$1.19

DISK DRIVE ENCLOSURES WITH POWER SUPPLIES

- CAB-23V5 DUAL SLIMLINE 5 1/4" \$49.95
- CAB-1FH5 FULL HT 5 1/4" \$89.95
- CAB-23V0 DUAL SLIMLINE 8" \$209.95
- CAB-2FH0 DUAL FULL HT 8" \$219.95

BUILD STEVE GIARCIA'S INTELLIGENT EPROM PROGRAMMER

AS SEEN IN BYTE, OCT. 85

- STAND-ALONE OR RS-232 SERIAL OPERATION
- MENU SELECTABLE EPROM TYPES - NO CONFIGURATION JUMPERS
- PROGRAMS ALL 5V 27XXX EPROMS FROM 2716 TO 27512
- READ, COPY OR VERIFY EPROM
- UPLOAD/DOWNLOAD INTEL HEX FILES
- PROGRAMMER DRIVER USER MODIFIABLE

Kit includes PCB & all components except case & power supply

\$199

20 MEG HARD DISK DRIVE ON A CARD

\$349!

TOTAL SYSTEM CONTROL FROM A SINGLE SLOT

SAVE THOSE VALUABLE SLOTS FOR SPECIALITY CARDS

MCT-MGMIO \$119.95

- HERCULES COMPATIBLE MONO-GRAPHICS, 720 x 384 PIXELS
- GAME PORT
- PARALLEL PORT & CLOCK / CALENDAR
- SERIAL PORT INCLUDED, OPTIONAL 2nd SERIAL AVAILABLE
- SUPPORTS BOTH DS / DD & DS / QD USING DOS 3.2 OR HIGHER



QUALITY IBM COMPATIBLE MOTHERBOARDS

TURBO 4.77 / 8 MHZ \$109.95

JDR PART #: MCT-TURBO

- 4.77 OR 8 MHZ OPERATION WITH 8088-2 & OPTIONAL 8087-2 CO-PROCESSOR
- DYNAMICALLY ADJUSTS SPEED DURING DISKETTE OPERATION FOR MAXIMUM THROUGHPUT AND RELIABILITY
- CHOICE OF NORMAL / TURBO MODE OR SOFTWARE SELECT PROCESSOR SPEED

STANDARD MOTHERBOARD \$97.95

JDR PART #: MCT-XTMB



80286 6 / 8 MHZ \$379.95

JDR PART #: MCT-ATMB

- 8 SLOT (2 EIGHT BIT, 6 SIXTEEN BIT) AT MOTHERBOARD
- HARDWARE SELECTION OF 6 OR 8 MHZ
- 1 WAIT STATE
- RESET SWITCH, FRONT PANEL LED INDICATOR AND KEYLOCK SUPPORTED
- SOCKETS FOR 1 MB OF RAM AND 80287 ON BOARD
- ON BOARD BATTERY BACKED CLOCK OPERATES WITH PC-DOS OR MS-DOS

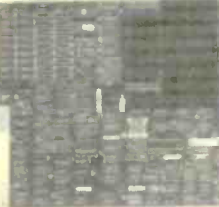

IBM COMPATIBLE 3 1/2" FDD KIT

JDR PART #: FDD-3.5 KIT

- 720K FORMAT, DOS 3.2 COMPATIBLE
- ALLOWS DATA INTERCHANGE WITH NEW IBM MACHINES
- MOUNTING HARDWARE FOR 5 1/4" SLOT
- BOTH AT & XT VERSIONS AVAILABLE

\$149.95

IBM COMPATIBLE FLOPPY DISK DRIVE

JDR PART #: FDD-380

- GOOD QUALITY DRIVES BY MAJOR MANUFACTURERS SUCH AS QUME, TANDON & CDC
- 5 1/4" HALF HEIGHT
- 360K STORAGE CAPACITY
- DS / DD
- 48 TPI

\$69.95

IBM XT STYLE COMPUTER CASE

AN ATTRACTIVE STEEL CASE WITH A HINGED LID. FITS THE POPULAR PC/XT COMPATIBLE MOTHERBOARDS



- SWITCH CUT-OUT ON SIDE FOR PC/XT STYLE POWER SUPPLY
- CUT-OUT FOR 8 EXPANSION SLOTS
- INCLUDES SPEAKER
- ALL HARDWARE INCLUDED

\$34.95

XT STYLE SLIDE TYPE CASE \$39.95
AT STYLE SLIDE TYPE CASE \$89.95

NICKEL EXPRESS PC/XT SPEED UP KIT FROM RIM ELECTRONICS

- INCREASE THE SPEED OF YOUR PC / XT OR CLONE BY 67% OR MORE!
- SIMPLE NO-SLOT INSTALLATION
- SOFTWARE OR HARDWARE SPEED SELECTION
- 8 MHZ V20 PROCESSOR & SOFTWARE INCLUDED
- SELECT FOR 3 TURBO FREQUENCIES
- EXTERNAL RESET SWITCH
- OPTIONAL 8088 8 MHZ PROCESSOR AVAILABLE
- KIT INCLUDES CABLING, TEST CLIP AND SWITCHES

\$69.95

PLEASE NOTE: Certain early PCs may not run at 8 MHz; these machines may be switched to one of the slower speeds: 6.66 MHz-40% 7.37 MHz-56% 8.0 MHz-67%

IBM COMPATIBLE KEYBOARDS

MCT-5060 \$59.95

- IBM AT STYLE LAYOUT
- SOFTWARE AUTOTENSE FOR XT OR AT COMPATIBLES
- EXTRA LARGE SHIFT & RETURN KEYS
- LED INDICATORS FOR SCROLL, CAPS & NUMBER LOCK
- AUTO REPEAT FEATURE

MCT-5339 \$79.95

- IBM ENHANCED STYLE LAYOUT
- SOFTWARE AUTOTENSE FOR XT OR AT COMPATIBLES
- 12 FUNCTION KEYS
- EXTRA LARGE SHIFT & RETURN KEYS
- LED INDICATORS FOR SCROLL, CAPS & NUMBER LOCK
- AUTO REPEAT FEATURE
- SEPARATE CURSOR PAD

MCT-5150 \$49.95
XT STYLE LAYOUT

MCT-5151 \$69.95
KBS151" EQUIVALENT

EASYDATA MODEMS

All models feature auto-dial/answer/redial on busy, Hayes compatible, power up self test, touchtone or pulse dialing, built-in speaker, PC Talk III Communications software, Bell Systems 103 & 212A full or half duplex and more.

INTERNAL

EASYDATA-12H \$79.95
1200 BAUD HALF CARD

EASYDATA-12B \$99.95
1200 BAUD 10" CARD

EASYDATA-24B \$179.95
2400 BAUD FULL CARD

EXTERNAL

NO SOFTWARE INCLUDED
EASYDATA-12D \$119.95
1200 BAUD

EASYDATA-24D \$219.95
2400 BAUD



MCT DISPLAY CARDS

MCT-EGA

100% IBM COMPATIBLE, PASSES IBM EGA DIAGNOSTICS

- COMPATIBLE WITH IBM EGA, COLOR GRAPHICS AND MONOCHROME ADAPTORS
- TRIPLE SCANNING FREQUENCY FOR DISPLAY ON EGA, STANDARD RGB OR HIGH RESOLUTION MONOCHROME MONITOR
- FULL 256K DR VIDEO RAM ALLOWS 640 x 350 PIXELS IN 16 OF 64 COLORS
- LIGHT PEN INTERFACE

\$149.95



MCT-CG

COMPATIBLE WITH IBM COLOR GRAPHICS STANDARD

- SHORT SLOT CARD USES VLSI CHIPS TO INSURE RELIABILITY
- SUPPORTS RGB, COMPOSITE MONOCHROME & COLOR AND AN RF MODULATOR OUTPUT
- 320 x 200 COLOR GRAPHICS MODE
- 640 x 200 MONOCHROME MODE
- LIGHT PEN INTERFACE

\$49.95



MCT-MGP

COMPATIBLE WITH IBM MONOCHROME AND HERCULES GRAPHICS STANDARDS

- SHORT SLOT CARD USES VLSI CHIPS TO INSURE RELIABILITY
- PARALLEL PRINTER PORT, CONFIGURABLE AS LPT1 OR LPT2
- 720 x 348 GRAPHICS MODE
- LOTUS COMPATIBLE
- CAN RUN WITH COLOR GRAPHICS CARD IN THE SAME SYSTEM

\$59.95



MCT DEVELOPMENT TOOLS

MCT-PAL

PAL PROGRAMMER

\$269.95

ONE ARRAY LOGIC CHIP CAN REPLACE 4-5 TTL ICs

- PROGRAMS 20 & 24 PIN PALS FROM TL, NSC & MMI
- EASY TO USE MENU-DRIVEN SOFTWARE ALLOWS PROGRAMMING, VERIFICATION READING, MAP BUILDING & BURNING THE SECURITY FUSE
- READ AND SAVE BURN PROFILES IN JEDEC FORMAT ON YOUR DISK

CUPL STARTER KIT \$49.95



MCT-MP

MICROPROCESSOR PROGRAMMER

\$199.95

PROGRAMS 8741/2/8/9 PROCESSOR CHIPS

- EASY TO USE MENU-DRIVEN SOFTWARE SUPPORTS READ, WRITE, BLANK CHECK AND VERIFY OPERATIONS
- PORT ADDRESS SELECTION IS USER CONFIGURABLE
- SAVE AND RESTORE PROGRAM IMAGES ON DISK
- INCLUDES SOFTWARE FOR STANDARD HEX AND INTEL HEX FORMATS



MCT-EPROM

EPROM PROGRAMMERS

\$129.95

PROGRAMS 27xx AND 27xxx SERIES EPROMS UP TO 27512

- SUPPORTS VARIOUS MANUFACTURERS FORMATS WITH 12.5, 21 AND 26 VOLT PROGRAMMING
- MENU-DRIVEN SOFTWARE ALLOWS EASY MANIPULATION OF DATA FILES
- SPLIT OR COMBINE THE CONTENTS OF SEVERAL EPROMS OF DIFFERENT SIZES
- READ, WRITE, COPY, ERASE CHECK AND VERIFY WITH EASY ONE KEY SELECTION
- INCLUDES SOFTWARE FOR STANDARD HEX AND INTEL HEX FORMATS

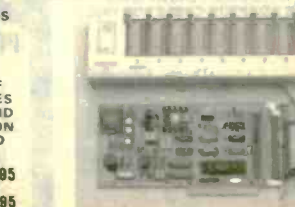

4 GANG PROGRAMMER \$189.95
10 GANG PROGRAMMER \$299.95

MCT PRODUCTS CARRY A ONE YEAR WARRANTY

INQUIRY 141 COPYRIGHT 1987 JDR MICRODEVICES

MODEM 1200 BAUD \$7995

FOR IBM WITH SOFTWARE

MODEM 2400 BAUD \$17995

MULTIFUNCTION CARDS

FROM MODULAR CIRCUIT TECHNOLOGY

MCT-MF \$79.95

ALL THE FEATURES OF AS TS SIX PACK PLUS AT HALF THE PRICE!

- 0-348K DYNAMIC RAM USING 4164s
- INCLUDES SERIAL PORT, PARALLEL PRINTER PORT, GAME CONTROLLER PORT AND CLOCK/CALENDAR
- SOFTWARE FOR A RAMDISK, PRINT SPOOLER AND CLOCK/CALENDAR



MCT-ATMF \$139.95

ADDS UP TO 3 MB OF 1 BIT RAM TO THE AT

- USER EXPANDABLE TO 1.5 MB OF ON-BOARD MEMORY (NO MEMORY INSTALLED)
- FLEXIBLE ADDRESS CONFIGURATION
- INCLUDES SERIAL PORT AND PARALLEL PORT
- OPTIONAL PIGGYBACK BOARD PERMITS EXPANSION TO 3 MB



ATMF-SERIAL 2nd SERIAL PORT \$249.95

MCT-ATMF-MC \$299.95

PIGGYBACK BOARD (ZERO K INSTALLED)

MCT-MIO \$79.95

A PERFECT COMPANION FOR OUR MOTHERBOARD

- 2 DRIVE FLOPPY DISK CONTROLLER
- INCLUDES SERIAL PORT, PARALLEL PORT, GAME PORT AND CLOCK/CALENDAR WITH BATTERY BACK-UP
- SOFTWARE FOR A RAMDISK, PRINT SPOOLER AND CLOCK/CALENDAR



MIO-SERIAL 2nd SERIAL PORT \$159.95

MCT-IO \$59.95

USE WITH MCT-FH FOR A MINIMUM OF SLOTS USED

- SERIAL PORT ADDRESSABLE AS COM1, COM2, COM3 OR COM4
- PARALLEL PRINTER PORT ADDRESSABLE AS LPT1 OR LPT2 (x378 OR x278)
- CLOCK/CALENDAR WITH A BATTERY BACK-UP



IO-SERIAL 2nd SERIAL PORT \$159.95

MCT-ATIO \$59.95

USE WITH MCT-ATFH FOR A MINIMUM OF SLOTS USED

- SERIAL PORT ADDRESSABLE AS COM1, COM2, COM3 OR COM4
- PARALLEL PRINTER PORT ADDRESSABLE AS LPTA OR LPTB (x378 OR x278)
- GAME PORT
- USES 16450 SERIAL SUPPORT CHIPS FOR HIGH SPEED OPERATION IN AN AT



ATIO-SERIAL 2nd SERIAL PORT \$249.95

RAM CARDS

FROM MODULAR CIRCUIT TECHNOLOGY

MCT-RAM \$59.95

A CONTIGUOUS MEMORY SOLUTION FOR YOUR SHORT OR REGULAR SLOT

- SHORT SLOT, LOW POWER PC COMPATIBLE DESIGN
- CAN OFFER UP TO 576K OF ADDITIONAL MEMORY
- USER SELECTABLE CONFIGURATION AMOUNTS OF 192, 384, 512, 256 & 576K USING COMBINATIONS OF 64 & 256K RAM



MCT-EMS \$129.95

2MB OF LOTUS/INTEL/MICROSOFT COMPATIBLE MEMORY FOR THE XT

- CONFORMS TO LOTUS/INTEL/EMS
- USER EXPANDABLE TO 2 MB
- USES 64K OR 256K DYNAMIC RAM (NO MEMORY INSTALLED)
- USE AS EXPANDED OR CONVENTIONAL MEMORY, RAMDISK OR SPOOLER
- SOFTWARE INCLUDES EMS DEVICE DRIVERS, PRINT SPOOLER AND RAMDISK



MCT-ATEMS \$139.95

CAN BE USED FOR CONVENTIONAL, EXPANDED OR EXTENDED MEMORY

- A FINE EXAMPLE OF FLEXIBILITY: OFFERS EXTENDED (AT MEMORY) OR EXPANDED (LIM/EMS) MEMORY AS WELL AS THE ABILITY TO FILL OUT CONVENTIONAL (640K) MEMORY
- 2 MEGABYTE CAPACITY IN A SINGLE SLOT
- RAMDISK, PRINT SPOOLER AND LIM/EMS SOFTWARE INCLUDED
- SPECIAL MEMORY MAP ANALYSIS INCLUDED



MCT-ATEMS-MC \$349.95

PIGGYBACK BOARD (ZERO K INSTALLED)



HALF HEIGHT HARD DISK DRIVES
40 MB 60 MB

Model ST-251 5 1/4" half height FAST 40ms access time

Model ST-277 5 1/4" half height FAST 40ms access time (FLL)

\$469

\$649

HALF HEIGHT HARD DISK SYSTEMS

20 MB 30 MB
\$299 \$329

Systems include half height hard disk drive, hard disk drive controller, cables and instructions. All drives are pre-tested and warranted for one year.

DISK CONTROLLER CARDS

FROM MODULAR CIRCUIT TECHNOLOGY

MCT-FDC \$29.95

QUALITY DESIGN OFFERS A FLOPPY CONTROL IN A SINGLE SLOT

- INTERFACES UP TO 4 FDDs TO AN IBM PC OR COMPATIBLE
- INCLUDES CABLING FOR 2 INTERNAL DRIVES
- USES STANDARD DB37 CONNECTOR FOR EXTERNAL DRIVES
- SUPPORTS BOTH DS/DD AND DS/3D WHEN USED WITH DOS 3.2 OR JFORMAT



MCT-HDC \$79.95

HARD DISK CONTROL FOR WHAT OTHERS CHARGE FOR FLOPPY CONTROL

- IBM XT COMPATIBLE CONTROLLER SUPPORTS 16 DRIVE SIZES INCLUDING 5, 10, 20, 30 & 40MB
- OPTIONS INCLUDE THE ABILITY TO DIVIDE 1 LARGE DRIVE INTO 2 SMALLER, LOGICAL DRIVES
- INCLUDES CABLING FOR 1 INTERNAL DRIVE



MCT-RLI \$119.95

GET UP TO 50% MORE STORAGE SPACE ON YOUR HARD DISK

- INCREASES THE CAPACITY OF PLATED MEDIA DRIVES BY 50%
- RLL 2, 7 ENCODING FOR MORE RELIABLE STORAGE
- TRANSFER RATE IS ALSO 50% FASTER: 750K/sec vs 500K/sec
- USE WITH ST-238 DRIVE TO ACHIEVE 30+ MB IN A HALF HEIGHT SLOT



MCT-FH \$139.95

STARVED FOR SLOTS? SATISFY IT WITH THIS TIMELY DESIGN

- INTERFACES UP TO 2 FDDs & 2 HDDs
- CABLING FOR 2 FDDs & 1 HDD
- FLOPPY INTERFACE SUPPORTS BOTH DS/DD & DS/3D WHEN USED WITH DOS 3.2 OR JFORMAT
- ALL POPULAR HDD SIZES ARE SUPPORTED, INCLUDING 5, 10, 20, 30 & 40MB
- CAN DIVIDE 1 LARGE DRIVE INTO 2 SMALLER, LOGICAL DRIVES



MCT-ATFH \$149.95

FLOPPY AND HARD DISK CONTROL IN A TRUE AT DESIGN

- AT COMPATIBLE, CONTROL UP TO 2 360K/720K OR 1.2MB FDDs AS WELL AS 2 HDDs USING THE AT STANDARD CONTROL TABLES
- SUPPORTS AT STYLE FRONT PANEL LED TO INDICATE HD ACTIVITY
- 16 BIT BUSS PROVIDES RAPID DATA TRANSFERS
- FULLY SUPPORTED BY AT BIOS



JDR Microdevices

110 Knowles Drive, Los Gatos, CA 95030

Inquiry 141

Toll Free 800-538-5000 • (408) 866-6200 • FAX (408) 378-8927 • Telex 171-110

THE JDR MICRODEVICES LOGO IS A REGISTERED TRADEMARK OF JDR MICRODEVICES. JDR INSTRUMENTS AND JDR MICRODEVICES ARE TRADEMARKS OF JDR MICRODEVICES. IBM IS A TRADEMARK OF INTERNATIONAL BUSINESS MACHINES CORPORATION.

BOMB

YOU CHOOSE THE BEST ARTICLE EACH MONTH

BYTE's ongoing monitor box (BOMB) lets you rate each article you've read in BYTE as excellent, good, fair, or poor. Each month, you can mail in the BOMB card found in the back of the issue. We tally your votes, total the points, tell you who won, and award the two top-rated nonstaff authors \$100

and \$50, respectively. An additional \$50 award for quality goes to the non-staff author with the best average score (total points divided by the number of voters). If you prefer, you can use BIX as your method of voting. We welcome your participation.

ARTICLE#	PAGE	ARTICLE	AUTHOR(S)	ARTICLE#	PAGE	ARTICLE	AUTHOR(S)
1	37	Microbytes	staff	15	199	Print Quality	Jansson
2	45	What's New	staff	16	209	Taming the Hot Heads	Davenport
3	68	Ask BYTE/Circuit Cellar Feedback	Ciarcia	17	215	Matrix-Line Printing	Hohneker
4	81	Book Reviews	Hoffman, Webber, Arndt	18	221	Color Thermal-Transfer Printing	Guardado
5	101	A Programmer's Introduction to OS/2	Duncan	19	225	Designing a High-Speed Page Printer Controller	Ellison
6	110	A Closer Look	Grehan	20	229	Strip-Buffer vs. Full-Page Bit-Map Imaging	Douglas
7	115	Ciarcia's Circuit Cellar: Build the Circuit Cellar AT Computer, Part 1: AT Basics	Ciarcia	21	239	The Kaypro 386	Duncan
8	123	Programming Project: Crafting Reusable Software in Modula-2	Oktaba, Berber	22	245	Mail-Order Performance	Davis
9	129	Programming Insight: Teaching Old Screens New Tricks	Sorens	23	253	The NEC MultiSpeed	Satz
10	137	Constructing an Associative Memory	Kosko	24	257	The Micro Clipper Graphics Subsystem	Weston
11	146	Karmarkar's Algorithm	Rockett, Stevenson	25	263	PC-MOS/386	Grehan
12	163	Color Printing	Luft	26	266	Actor 1.0	Moskowitz
13	177	Vector-to-Raster Algorithms	Pountain	27	269	ALS Prolog	Lane
14	187	Page Printers	Cook	28	277	Benchmarking dBASE III Plus Compilers	Rubel
				29	281	DESQview 2.00	McCormick
				30	289	Computing at Chaos Manor: In the Chips	Pournelle
				31	307	Applications Only: Potpourri	Shapiro
				32	317	Best of BIX	BIXen

BOMB RESULTS

The winning entries for June indicate that our readers have a great deal of interest in new IBM products. First place goes to the BYTE editorial staff for "First Impressions: The IBM PS/2 Computers." In second place is "Microsoft's New DOS" (aka OS/2) by Eva White and Richard Grehan of BYTE's editorial staff. "Puttering with Yin and Yang," the activity that took place at Chaos Manor, gave third place to Jerry Pournelle. It wasn't only new IBM products that garnered attention. What's New from the BYTE staff took the fourth-place award. Ciarcia's Circuit

Cellar for June wound up in the fifth position. In it, Steve showed how to "Build a Gray-Scale Video Digitizer, Part 2: Digitizer/Transmitter." The BYTE staff shows up again in sixth place, this time for Microbytes. In seventh place overall, and winner of \$100 as the highest nonstaff vote gatherer, is William G. Hood for his Programming Insight, "Polynomial Curve Fitter." In eighth place, and winner of \$50, is Paul D. Bourke for his Programming Project, "A Contouring Subroutine." Mr. Hood wins the \$50 bonus award for quality. Congratulations to all.

COMING UP IN BYTE

Features:

A survey of application packages that run under OS/2; Jef Raskin's new Cat "information appliance"; Acorn debuts the world's first commercial RISC machine, and Dick Pountain looks at it.

Circuit Cellar:

The concluding section on building an IBM PC AT clone.

Programming Insight:

An algorithm for deriving Xmodem cyclic redundancy checks.

Theme:

Heuristic algorithms includes articles on zero-knowledge proofs, back propagation and general learning

rules, compiler optimization heuristics, a search strategy for common sense, PRESS—the Prolog equation solver system, and an introduction to neural networks.

Reviews:

The Macintosh II, the GRiDLite Portable, and the new Wang Portable are system reviews. Definicon's DSI-780 and a survey of four laser printers cover peripherals. Language reviews include three libraries of windowing menu design and data-form entry routines, as well as a comparison of two low-cost, low-functionality C-language packages. Application software reviews include an examination of Guide and a comparison of MathCAD, Eureka: The Solver, and Point Five equation-solving programs. We'll also have a review of a package said to be based on forward- and backward-chaining techniques, Personal Consultant Plus.

EDITORIAL INDEX BY COMPANY

Index of companies covered in articles, columns, or news stories in this issue.
Each reference is to the first page of the article or section in which the company name appears.

COMPANY	PAGE	COMPANY	PAGE	COMPANY	PAGE
A.I. ARCHITECTS	45	FOUNDATION PUBLISHING	307	OFFICE AUTOMATION SYSTEMS	229
ACADEMIC INFORMATION SYSTEMS	37	FOX SOFTWARE	277	ON! SYSTEMS	45
ADAPTIVE	307	FUJITSU AMERICA	45	OWL INTERNATIONAL	307
ADOBE SYSTEMS	187	GENERAL COMPUTER	45	PC DESIGNS	245
ADVANCED COLOR TECHNOLOGY	163	GENERIC SOFTWARE	37	PC'S LIMITED	257
ADVANCED LOGIC RESEARCH	239	GOLDEN BOW SYSTEMS	289	PERSONAL COMPUTER SUPPORT	
ADVANCED MICRO DEVICES	245	GRAPHIC SOFTWARE SYSTEMS	37	GROUP	45
ALDUS	37	GREAT SOFTWESTERN	257	PHOENIX COMPUTER PRODUCTS	277
ALTOS COMPUTER SYSTEMS	45	HAYES MICROCOMPUTER		PIXELWORKS	257
AMDEK	289	PRODUCTS	239, 253	POSEIDON	307
APIAN SOFTWARE	45	HECHT-NIELSEN NEUROCOMPUTER	37	POTOMAC ELECTRIC POWER	37
APPLE COMPUTER	37, 187, 307	HERCULES	239, 277	PRIAM	277
APPLIED LOGIC SYSTEMS	263	HEWLETT-PACKARD	45, 163	PRINTRONIX	215
APPLIED RESEARCH	45	HITACHI	239	QMS	45, 307
ASHTON-TATE	277	HOWTEK	163	QUADRAM	45, 277
AST	277	HUMAN DEVICES	37	QUARTERDECK OFFICE	
AT&T	277	IBM	37, 101, 115, 177, 187, 239, 245, 253, 257, 277	SYSTEMS	239, 245, 277, 289
ATARI	187	IDS	257	RICOH	225
AVANT GARDE SYSTEMS	289	INTECOLOR	289	RODIME	45
BENSON	163	INTEL	37, 101, 239, 245, 289	SABA TECHNOLOGIES	45
BIOSCAN	45	KAYPRO	239, 253, 289	SAM FENSTER	45
BITSTREAM	187	KEY TRONIC	245	SAMSUNG	257
BLYTH SOFTWARE	37	KYOCERA	187	SEAGATE	245
BONDWELL	253	LABORATORY MICROSYSTEMS	239	SOFTKLONE DISTRIBUTING	307
BORLAND INTERNATIONAL	263, 289	LASERPORT	187	SOFTLOGIC SOLUTIONS	45
BRODERBUND SOFTWARE	307	LIVING VIDEOTEXT	37	SOFTWARE 2000	277
C LTD.	45	LOGITECH	257, 277	STORAGE DIMENSIONS	239, 289
C. ITOH	187	LOTUS DEVELOPMENT	239, 245	STRATEGIC SIMULATIONS	37
CALCOMP	221	MARTINGALE RESEARCH	37	SUPRA	45
CANON	225	MAXI-SWITCH	245	TALLTREE	187
CCI	115	MAYNARD	277	TANDON	307
CHEETAH INTERNATIONAL	245, 289	MEASUREMENT TECHNOLOGY	45	TAXAN USA	187
CHIPS AND TECHNOLOGIES	239, 245	MEGAHERTZ	45	TEAC	245
CHORUS DATA SYSTEMS	187	MICRO ILLUSIONS	289	TELE-WARE WEST	245
COMMODORE BUSINESS MACHINES	37	MICROGRAFX	45	TELEVIDEO	257
COMPAQ	239, 257, 263, 277	MICROMINT	115	TEXAS INSTRUMENTS	37, 45, 177
CONWAY DATA	253	MICROPORT SYSTEMS	45, 245	THE SOFTWARE LINK	263
CONWAY DATA	253	MICROPRO	239	THE SOFTWARE TOOLWORKS	289
CORE INTERNATIONAL	239	MICROPRODUCTS	45	THE WHITEWATER GROUP	263
CRAY	37	MICRORIM	239	TOSHIBA	253
DATA GENERAL	45, 253	MICROSOFT	101, 239, 245, 263	TRILLIUM	45
DATAMEDIA	45	MICROSOLUTIONS COMPUTER		ULTRA	37
DATASTORM	239	PRODUCTS	45	VARITYPER	187
DATAVUE	253	MIRROR TECHNOLOGIES	45	VIDEO-7	239, 245
DATEK INFORMATION SERVICES	163	MODERN GRAPHICS	45	VISION	277
DEFINICON SYSTEMS	289	MORGAN COMPUTING	239	WESTERN DIGITAL	245
DIGITAL RESEARCH	245	MOTOROLA	101, 255	WINTECH	245
DP-TEK	187	MSB MUSIC SOFTWARE	45	WORDTECH SYSTEMS	277
ELECTRONIC FORMS SYSTEMS	187, 225	MULTI-TECH SYSTEMS	45	XEROX	177, 187, 225, 289
EPSON AMERICA	257	NANTUCKET	277	ZENITH DATA SYSTEMS	253, 289
EVEREX	245	NEC HOME ELECTRONICS	245, 253, 257	ZYMOS	115
FACIT	199	NEURAL SYSTEMS	45		
FIFTH GENERATION SYSTEMS	239	NEURONICS	37		
FLAGSTAFF ENGINEERING	45	NEWBURY DATA RECORDING	209		
		NOVELL	277		

Limited Edition **BYTE** Collector Prints

#A



Intelligent Reflections

#B

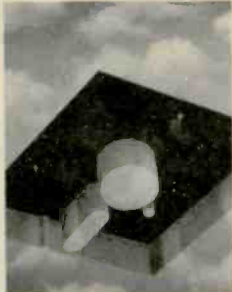

Storage Space



Technological Breakthrough



Number Crunching

#C

#D

Popular *Byte* cover artist Robert Tinney proudly offers these flawless art prints, each individually signed and numbered, and part of an edition strictly limited to 1000 prints. Each is printed on 16" x 20", museum grade acid-free stock to ensure brilliance and flexibility for decades to come. The color separations for these sumptuous prints are made *directly from the original paintings*, helping to guarantee accurate reproduction. Robert

Tinney himself personally inspects, signs and numbers each individual print, along with a Certificate of Authenticity which certifies the number limit and the destruction of the press plates.

The price of these beautiful limited editions is just \$55, or \$45 each if you order two or more. Your prints will be shipped flat via UPS Blue Label (2-day delivery), and carry an unconditional 30-day guarantee. VISA, MasterCard or AmEx orders may call 1-504-272-7266 daytime or evenings. Order now!

ORDER FORM

Send me the following Prints at \$55, or \$45 each for 2 or more.

QTY	Title and #	Amount
_____	_____	\$ _____
_____	_____	\$ _____
_____	_____	\$ _____
\$4 postage & handling (\$15 overseas)		\$ _____
Total		\$ _____

- I have enclosed check or money order to Robert Tinney Graphics.
 Please send my prints C.O.D. (UPS --- Include street address).
 Bill my VISA MasterCard American Express account.

Card No.: _____ Expires: _____

Name: _____

Address: _____

City: _____ State: _____ Zip: _____

- Please send me your
FREE color brochure.



ROBERT TINNEY GRAPHICS
1864 N. Pamela Dr.
Baton Rouge, Louisiana 70815

BYTE ADVERTISING SALES STAFF:

Dennis J. Riley, Advertising Sales Manager, One Phoenix Mill Lane, Peterborough, NH 03458, tel. (603) 924-9281

NEW ENGLAND

ME, NH, VT, MA, RI,
ONTARIO, CANADA & EASTERN CANADA
Paul McPherson Jr. (617) 262-1160
McGraw-Hill Publications
575 Boylston Street
Boston, MA 02116

ATLANTIC

NY, NYC, CT, NJ (NORTH)
Leah G. Rabinowitz (212) 512-2096
McGraw-Hill Publications
1221 Avenue of the Americas—
39th Floor
New York, NY 10020

Dick McGurk (203) 968-7111
McGraw-Hill Publications
Building A—3rd Floor
777 Long Ridge Road
Stamford, CT 06902

EAST

PA, KY, OH, NJ (SOUTH),
MD, VA, W.VA, DE, D.C.
Daniel Ferro (215) 496-3833
McGraw-Hill Publications
Three Parkway
Philadelphia, PA 19102

NORTHEAST MAIL ORDER AND RETAIL ACCOUNTS

Bill Watson (603) 924-7255
One Phoenix Mill Lane
Peterborough, NH 03458

SOUTHEAST

NC, SC, GA, FL, AL, TN
Carolyn F. Lovett (404) 252-0626
McGraw-Hill Publications
4170 Ashford-Dunwoody Road
Suite 420
Atlanta, GA 30319

MIDWEST

IL, MO, KS, IA, ND, SD, MN, WI,
NB, IN, MI, MS
Bob Denmead (312) 751-3740
McGraw-Hill Publications
Blair Building
645 North Michigan Ave.
Chicago, IL 60611

SOUTHWEST, ROCKY MOUNTAIN

CO, WY, OK, TX, AR, LA
(214) 644-1111
McGraw-Hill Publications
8111 LBJ Freeway—Suite 1350
Dallas, TX 75251

SOUTH PACIFIC

SOUTHERN CA, AZ, NM, LAS VEGAS
Jack Anderson (714) 557-6292
McGraw-Hill Publications
3001 Red Hill Ave,
Building #1—Suite 222
Costa Mesa, CA 92626

Tom Harvey (213) 480-5243

McGraw-Hill Publications
3333 Wilshire Boulevard #407
Los Angeles, CA 90010

NORTH PACIFIC

HI, WA, OR, ID, MT, NORTHERN CA,
NV (except LAS VEGAS), UT,
W. CANADA
Mike Kisseberth (415) 362-4600
McGraw-Hill Publications
425 Battery Street
San Francisco, CA 94111

Bill McAfee (415) 349-4100

McGraw-Hill Publications
951 Mariner's Island Blvd.—3rd Floor
San Mateo, CA 94404

The Buyer's Mart (1x2)

Mark Stone (603) 924-3754
BYTE Publications
One Phoenix Mill Lane
Peterborough, NH 03458

BYTE BITS (2x3)

Dan Harper (603) 924-6830
BYTE Publications
One Phoenix Mill Lane
Peterborough, NH 03458

BYTE Deck Mailings

National
Ed Ware (603) 924-6166
BYTE Publications
One Phoenix Mill Lane
Peterborough, NH 03458

A/E/C Computing Deck

Mary Ann Goulding (603) 924-9281
BYTE Publications
One Phoenix Mill Lane
Peterborough, NH 03458

International Advertising Sales Staff:

Mr. Hans Csokor
Publimedia
Reinaserstrasse 61
A-1037 Vienna, Austria
222 75 76 84

Mrs. Gurlt Gepner
McGraw-Hill Publishing Co.
PO Box 2156
Bat Yam, 59121 Israel
3 866 561 321 39

Mr. Fritz Krusebecker
McGraw-Hill Publishing Co.
Liebigstrasse 19
D-6000 Frankfurt/Main 1
West Germany
69 72 01 81

Mrs. Maria Sarmiento
McGraw-Hill Publishing Co.
Iberia Mart I
Madrid 4, Spain
1 45 52 891

Mr. Gert Moberg
Andrew Karnig & Associates
Finnbodavagn
S-131 31 Nacka, Sweden
8-44 0005

Mr. Alain Faure
McGraw-Hill Publishing Co.
128 Faubourg Saint Honore
75008 Paris
France
(1) 42-89-03-81

Mr. Arthur Scheffer
McGraw-Hill Publishing Co.
34 Dover St.
London W1X 3RA
England 01 493 1451

Manuela Capuano
McGraw-Hill Publishing Co.
Via Flavio Baracchini 1
20123 Milan, Italy
02 86 90 617

Seavex Ltd.
400 Orchard Road, #10-01
Singapore 0923
Republic of Singapore
Tel: 734-9790
Telex: RS35539 SEAVEX

Seavex Ltd.
503 Wilson House
19-27 Wyndham St.
Central, Hong Kong
Tel: 5-2601-49
Telex: 60#04 SEVEX HX

Hiro Morita
McGraw-Hill Publishing Co.
Overseas Corp.
Room 152B
Kasumigaseki Bldg.
3-2-5 Kasumigaseki,
Chiyoda-Ku
Tokyo 100, Japan
3 581 9811

Mr. Ernest McCrarty
Empresa Internacional de
Comunicacoes Ltda.
Rua da Consolacao, 222
Conjunto 103
01302 Sao Paulo, S.P., Brasil
Tel: (11) 259-3811
Telex: (100) 32122 EMBN

READER SERVICE

To get further information on the products advertised in BYTE, fill out the reader service card by circling the numbers on the card that correspond to the inquiry number listed with the advertiser. This index is provided as an additional service by the publisher, who assumes no liability for errors or omissions.

* Correspond directly with company

Alphabetical Index to Advertisers

Inquiry No.	Page No.	Inquiry No.	Page No.	Inquiry No.	Page No.	Inquiry No.	Page No.
328 3M COMPANY	112,113	68 CUSTOM SOFTWARE	183	198 LASERPRO	186	152 PROGRAMMER'S PARADISE	88,89
3 ABSOFT	320	69 C-COR ELECTRONICS	125	199 LASERPRO	186	234 PROGRAMMER'S SHOP	291
334 AD LIB INC.	323	70 C. ITOH	234	150 LATTICE INC.	44	336 PROG'S SHOP/STERLING CASTLE	293
4 ADOBE	203	71 C. ITOH	234	151 LAWSON LABS	358	337 PROG'S SHOP/COMPUVIEW	293
5 ADVANCED COMP. PROD.	357	72 DALCO ELECTRONICS	362	153 LIFEBOAT ASSOCIATES	207	338 PROG'S SHOP/POLYTRON	293
340 ADVANCED LOGIC RESEARCH	313	347 DATA BUREAU	366	154 LINK COMP. GRAPHICS	366	339 PROGRAMMER'S SHOP	293
341 ADVANCED LOGIC RESEARCH	313	73 DATA TRANSLATION	73	155 LOGICAL DEVICES	70	236 PROTEUS TECHNOLOGY CORP.	55
7 ALBERTO-CULVER CO.	22	82 DCS	364	156 LOGICAL DEVICES	70	239 QUA TECH	312
8 ALF PRODUCTS	94	75 DICONIX	100	157 LOGICAL SYSTEMS CORP.	320	240 QUA TECH	312
* ALLEN SYSTEMS	364	76 DIGITAL PRODUCTS	26	158 LOGITECH	59	241 QUA TECH	312
9 ALPHA PRODUCTS	351	77 DIGITALK INC.	93	159 LOGITECH	59	242 QUA TECH	312
10 ALPHA PRODUCTS	358	78 DISKOTECH	356	160 LOGITECH	61	243 QUA TECH	312
11 ALPS AMERICA	66,67	79 DISKETTE CONNECTION	349	161 LOGITECH	61	244 QUA TECH	312
12 ALPS AMERICA	66,67	58 DISKMASTER	352	162 LOGITECH	63	* QUAID SOFTWARE	86
352 ALSYS LTD.	10,11	80 DISKS PLUS	272	163 LOGITECH	63	335 QUANTUM SOFTWARE LTD.	136
14 AMDEK CORPORATION	132,133	81 DISKS PLUS	335	* LOTUS DEVELOPMENT	76,79	245 QUBIE	80
* AMER. DESIGN COMPONENTS	363	* DOW JONES NEWS/RETRIEVAL	309	* LOTUS DEVELOPMENT	139	246 QUBIE	80
16 AMERICAN SEMICONDUCTOR	319	83 DRESSELHAUS COMP. PROD.	120	164 MACMILLAN SOFTWARE CO.	29	247 QUELO INC.	370
17 AMERICAN SMALL BUSN. COMP.	91	84 DYNAMIC ELECTRONICS CO.	366	165 MANX SOFTWARE SYSTEMS	121	248 QUINN-CURTIS	352
* AMPRO COMPUTER INC.	201	85 EASTMAN KODAK CO.	53	166 MANX SOFTWARE SYSTEMS	169	249 RADIO SHACK	CIV
* ANTHRO CORP.	14	86 ECHELON	82	167 MARK WILLIAMS CO.	20	* RAIMA CORP.	16
18 APPLIED MICRO TECH	354	87 ECOSOFT	332	168 MARK WILLIAMS CO.	21	250 REAL TIME DEVICES	352
19 APROTEK	356	348 EI & S	366	169 MARK WILLIAMS CO.	23	251 ROSE ELECTRONICS	366
238 ARITY CORPORATION	85	88 ELLEXOR INC.	356	170 MARKENRICH CORP.	362	252 ROYAL AMERICAN TECHN.	308
* AST RESEARCH	128A1-6	89 ELLIS COMPUTING	299	* MAXELL DATA PRODUCTS	7	253 RYAN MCFARLAND CORP.	191
331 ATI TECHNOLOGIES	251	90 ENGINEERS COLLABORATIVE	354	* MCGRAW-HILL INFO. SERV.	304,305	254 SAFEWARE	358
21 ATRON CORPORATION	259	91 EVEREX SYSTEMS	19	* MCGRAW-HILL NRI SCHOOLS	321	255 SAI SYSTEMS LABS	350
22 ATRONICS INT'L. INC.	217	92 EVEREX SYSTEMS	19	171 MEAD COMPANY	365	256 SBT CORPORATION	252
23 AUTOSKETCH INC.	261	93 FACIT AB	159	172 MEDIA CYBERNETICS	77	344 SCIENCE & ENGINEERING SW	361
24 AVOCET SYSTEMS INC.	208	103 FHL	370	173 MEGASOFT	358	258 SCR CORPORATION	349
342 BASIS INC.	327	95 FLAGSTAFF ENGINEERING	288	174 MEGATEL COMPUTER TECH	158	259 SEAGATE TECHNOLOGY	150,151
343 BASIS INC.	327	96 FLAGSTAFF ENGINEERING	288	175 MERRITT COMP. PRODS.	354	260 SEAGATE TECHNOLOGY	150,151
25 BAY TECHNICAL ASSOC.	165	99 FORTRON CORPORATION	250	176 MICROCOM SYSTEMS	72	261 SEALEVEL SYSTEMS	350
* BEST WESTERN	120	324 FOSTER TECHNOLOGY	364	* MICROMINT	329	262 SILICON SPECIALTIES	87
26 BINARY TECHNOLOGY INC.	362	101 FOX SOFTWARE	109	177 MICROPROCESSORS UNLTD	364	263 SILICON SPECIALTIES	87
425 BIX/MICROBYTES	284	102 FRANK HOGG LABORATORY	352	178 MICROSERVE	176	264 SOFTCRAFT INC. (TX)	31
450 BIX	285	104 FTG DATA SYSTEMS	366	179 MICROSERVE	176	265 SOFTCRAFT INC. (WI)	98
29 BORLAND INT'L.	CII,J	* GALACTICOMM INC.	248	182 MICROSOFT CORP.	56,57	266 SOFTCRAFT INC. (WV)	98
30 BORLAND INT'L.	CII,J	105 GENERAL IMAGING CORP.	295	* MICROSOFT CORP.	64B1-4	267 SOFTKONE DISTRIBUTING	242
31 BORLAND INT'L.	303	106 GENERIC SOFTWARE	315	180 MICROSOFT CORP.	69	* SOFTLINE CORPORATION	95
32 BORLAND INT'L.	303	107 GENERIC SOFTWARE	315	181 MICROSOFT CORP.	69	269 SOFTRONICS	320
33 BP MICROSYSTEMS	370	108 GENICOM	237	* MICROSOFT CORP.	179	270 SOFTWARE DEVLPMNT. SYS.	290
* BUSINESS WEEK	276	109 GENOA SYSTEMS	47	* MICROSOFT CORP.	286	325 SOFTWARE LINK, THE	25
* BUYER'S MART	336-344	110 GLOBAL COMP. SUPPLIES	349	* MICROWAY	270	326 SOFTWARE LINK, THE	25
* BYTE BACK ISSUES	360	111 GOLDEN BOW SYSTEMS	349	184 MICROWAY	114	272 SOLUTION SYSTEMS	294
351 BYTE BITS	370	112 GOLDEN BOW SYSTEMS	364	185 MINORITY HIGH TECH IND.	300	273 SOURCE ELECTRONICS	94
* BYTE CIRCULATION	331	113 GRAFPOINT	364	186 MITSUBISHI ELECTRONICS	171	274 SPECTRUM SOFTWARE	213
* BYTE MARKETING	334	114 GRAND UNION MICRO SYS.	350	187 MITSUBISHI ELECTRONICS	171	275 SPSS INC.	214
* BYTE SUB. MESSAGE	207	* HARMONY COMPUTERS	30	188 MITSUBISHI ELECTRONICS	173	257 SST/QUANTUS	306
* BYTE SUB. SERVICE	292	115 HAYES MICROCOMP. PROD.	42,43	189 MITSUBISHI ELECTRONICS	173	276 STAR MICRONICS	185
34 BYTEK CORPORATION	172	116 HERCULES COMPUTER TECH.	153	190 MIX SOFTWARE	105	277 SUBLOGIC CORP.	51
35 B & B ELECTRONICS	352	117 HERCULES COMPUTER TECH.	153	* MOTOROLA SEMICNDTR.	218,219	278 SUNCOAST SYSTEMS INC.	84
36 B & C MICROSYSTEMS	349	118 HERCULES COMPUTER TECH.	155	191 M-S CORP.	356	279 SUNCOAST SYSTEMS INC.	84
37 B & C MICROSYSTEMS	358	119 HERCULES COMPUTER TECH.	155	192 NANTUCKET	39	280 SUNTRONICS CO. INC.	345
38 B & C MICROSYSTEMS	370	120 HERCULES COMPUTER TECH.	157	193 NANTUCKET	39	281 SUPERSELL SOFTWARE INC.	33
39 CAD SOFTWARE	335	121 HERCULES COMPUTER TECH.	157	194 NATIONAL INSTRUMENTS	28	282 SWISSCOMP INC.	354
* CALIFORNIA DIGITAL	353	122 HERSEY MICRO CONSULTING	314	196 NEC HOME ELECTR. USA	134,135	283 S'NW ELECTRONICS	184
40 CANON U.S.A.	196	123 HEWLETT-PACKARD	206	197 NEC INFORMATION SYS.	C111	284 S-100 DIV/696 CORP.	355
41 CANON U.S.A.	197	124 HITECH EQUIPMENT	364	200 OFFICE & COMP. SUPPLIES INC.	354	285 S-100 DIV/696 CORP.	355
42 CAPITAL EQUIPMENT	74	125 HOOLEON COMPANY	160	201 OLYMPIA U.S.A. INC.	75	286 TALKING TECHNOLOGY	352
43 CAPITAL EQUIPMENT	294	126 HOOLEON COMPANY	160	202 OMNITRONIX INC.	366	287 TANDON	301
44 CENTRAL COMPUTER PROD.	366	127 HOUSTON INSTR./AMETEK	27	345 ONLINE ACCESS	262	288 TANDON	301
45 CENTRAL POINT SOFTWARE	184	128 IBEX COMP. CORP.	370	203 ORCHID TECHNOLOGY	36	289 TDK ELECTRONICS CORP.	103
* CITICORP/DINER'S CLUB	167	129 INES GMBH	356	204 ORCHID TECHNOLOGY	36	290 TELEBYTE TECHNOLOGY	271
47 CITIZEN AMERICA	17	130 INNER LOOP SOFTWARE	354	207 ORIENTAL PRECISION CO.	82	291 TELEX COMMUNICATIONS	228
* CLEO SOFTWARE	298	131 INTECTRA	358	208 ORION INSTRUMENTS	220	292 TELEX COMMUNICATIONS	228
48 CLUB AT	34,35	132 INTEGRAND RESEARCH	326	209 OSBORNE/MCGRAW-HILL	244	293 TIGERTRONICS	158
* CODEX CORPORATION	122	346 INTERFACE GROUP	316	210 OSBORNE/MCGRAW-HILL	311	294 TIGERTRONICS	362
49 COGITATE	349	350 INTERFACE GROUP	325	211 OVERLAND DATA INC.	249	295 TIMELINE	348
50 COGITATE	358	133 IO TECH	364	212 OVERLAND DATA INC.	249	* TINNEY, ROBERT GRAPHICS	279
* COMB. DIRECT MKTG. CORP.	367	134 I.C. EXPRESS	362	213 PAMCO	356	* TINNEY, ROBERT GRAPHICS	333
52 COMPACT DISC PRODS. INC.	202	135 JADE COMPUTER	368,369	214 PATTON & PATTON	18	* TINNEY, ROBERT GRAPHICS	380
* COMPAQ	231-233	136 JAMECO ELECTRONICS	346,347	216 PCPI	49	* TOSHIBA AMERICA INC.	8,9
53 COMPETITIVE EDGE	160	137 JDR INSTRUMENTS	223	217 PCPI	49	* TOSHIBA AMERICA INC.	143
54 COMPUSAVE	345	138 JDR MICRODEVICES	371	218 PCPRIME SYSTEMS	364	* TOSHIBA AMERICA INC.	198
55 COMPUSERVE	297	139 JDR MICRODEVICES	372,373	221 PECAN SOFTWARE SYS.	108	296 TRIGGS DATA SYSTEMS INC.	90
59 COMPUTER BOOK CLUB	273	140 JDR MICRODEVICES	374,375	222 PERMA POWER ELECTRONICS	196	297 TRI-STATE COMPUTER	344
* COMPUTER CONTINUUM	352	141 JDR MICRODEVICES	376,377	223 PERMA POWER ELECTRONICS	196	298 TURBOPOWER SOFTWARE	292
60 COMPUTER FRIENDS	360	333 JOHN BELL ENGINEERING	350	225 PERSONAL TEX	92	299 T & T COMPUTER PROD.	358
* COMPUTER MAIL ORDER	161A1-12	143 J & R MUSIC WORLD	226	226 PERSTOR SYSTEMS INC.	74	300 UNIVERSAL CROSS-ASSEMBLRS.	354
62 COMPUTER PARTS GALORE	296	144 KADAK PRODUCTS LTD.	362	227 PERSTOR SYSTEMS INC.	74	301 UNIVERSAL DATA SYSTEMS	83
63 COMPUTER SURPLUS STORE	362	145 KEA SYSTEMS	350	228 PETER NORTON	41	6 UPS-DEPOT	370
64 COMPUTER VALLEY	359	146 KEA SYSTEMS	350	229 PETER NORTON	41	302 USROBOTICS INC.	283
65 COMPUTER WAREHOUSE	224	147 KEITHLEY/DAC	24	230 PETER NORTON	274,275	303 USROBOTICS INC.	283
66 COMPUTER WAREHOUSE	224	330 KOHI-NOOR RAPIDOGRAPH	243	231 PETER NORTON	274,275	304 VEN-TEL CORP.	13
67 CONTECH	349	148 KORTEK	96,97	232 PINECOM COMP. INC.	359	305 VICTORY ENTERPRISES	197
329 CSI	227	149 LABORATORY TECHNOLOGY	175	233 PIXELAR	210	306 VISIONICS CORP.	84

READER SERVICE

To get further information on the products advertised in BYTE, fill out the reader service card by circling the numbers on the card that correspond to the inquiry number listed with the advertiser. This index is provided as an additional service by the publisher, who assumes no liability for errors or omissions.

* Correspond directly with company

Index to Advertisers by Product Category

Inquiry No.	Page No.	Inquiry No.	Page No.	Inquiry No.	Page No.	Inquiry No.	Page No.
HARDWARE							
9 ALPHA PRODUCTS	351	328 3M COMPANY	112,113	301 UNIVERSAL DATA SYSTEMS	83	* COMB DIRECT MKTG. CORP.	367
10 ALPHA PRODUCTS	358	52 COMPACT DISC PRODS. INC.	202	302 USROBOTICS INC.	283	* COMPAQ	231-233
22 ATRONICS INT'L. INC.	217	67 CONTECH	349	303 USROBOTICS INC.	283	53 COMPETITIVE EDGE	160
42 CAPITAL EQUIPMENT	74	95 FLAGSTAFF ENGINEERING	288	304 VEN-TEL CORP.	13	102 FRANK HOGG LABORATORY	352
43 CAPITAL EQUIPMENT	294	96 FLAGSTAFF ENGINEERING	288	MONITORS			
90 ENGINEERS COLLABORATIVE	354	109 GENOA SYSTEMS	47	14 AMDEK CORPORATION	132,133	174 MEGATEL COMPUTER TECH	158
116 HERCULES COMPUTER TECH.	153	128 IBEX COMP. CORP.	370	331 ATI TECHNOLOGIES	251	196 NEC HOME ELECTR. USA	134,135
117 HERCULES COMPUTER TECH.	153	* MAXELL DATA PRODUCTS	7	186 MITSUBISHI ELECTRONICS	171	207 ORIENTAL PRECISION CO.	82
118 HERCULES COMPUTER TECH.	155	211 OVERLAND DATA INC.	249	187 MITSUBISHI ELECTRONICS	171	218 PCPRIME SYSTEMS	364
119 HERCULES COMPUTER TECH.	155	212 OVERLAND DATA INC.	249	188 MITSUBISHI ELECTRONICS	173	245 QUBIE'	80
120 HERCULES COMPUTER TECH.	157	290 TELEBYTE TECHNOLOGY	271	189 MITSUBISHI ELECTRONICS	173	246 QUBIE'	80
121 HERCULES COMPUTER TECH.	157	306 VISIONICS CORP.	84	275 SPSS INC.	214	249 RADIO SHACK	CIV
350 INTERFACE GROUP	325	MISCELLANEOUS				255 SAI SYSTEMS LABS	350
133 IO TECH	364	25 BAY TECHNICAL ASSOC.	165	257 SST/QUANTUS	306	280 SUNTRONICS CO. INC.	345
333 JOHN BELL ENGINEERING	350	45 CENTRAL POINT SOFTWARE	184	287 TANDON	301	288 TANDON	301
154 LINK COMP. GRAPHICS	366	69 C-COR ELECTRONICS	125	* TOSHIBA AMERICA INC.	143	* TOSHIBA AMERICA INC.	198
* MICROMINT	329	72 DALCO ELECTRONICS	362	309 WELLS AMERICAN	15	313 WHOLE EARTH ELECTRONICS	32
194 NATIONAL INSTRUMENTS	28	73 DATA TRANSLATION	73	TERMINALS			
203 ORCHID TECHNOLOGY	36	80 DISKS PLUS	272	146 KEA SYSTEMS	350	SOFTWARE	
204 ORCHID TECHNOLOGY	36	81 DISKS PLUS	335	APPLE2/MAC LANGUAGES			
226 PERSTOR SYSTEMS INC.	74	91 EVEREX SYSTEMS	19	165 MANX SOFTWARE SYSTEMS	121	ATARI/AMIGA LANGUAGES	
227 PERSTOR SYSTEMS INC.	74	92 EVEREX SYSTEMS	19	166 MANX SOFTWARE SYSTEMS	169	3 ABSOFT	320
233 PIXELAR	210	105 GENERAL IMAGING CORP.	295	ATARI/AMIGA UTILITIES			
261 SEALEVEL SYSTEMS	350	124 HITECH EQUIPMENT	364	247 QUELO INC.	370	IBM/MS-DOS APPLICATIONS— Business/Office	
307 VOYETRA TECH	362	125 HOOLEON COMPANY	160	49 COGITATE	349	340 ADVANCED LOGIC RESEARCH	313
DRIVES							
85 EASTMAN KODAK CO.	53	126 HOOLEON COMPANY	160	50 COGITATE	358	341 ADVANCED LOGIC RESEARCH	313
259 SEAGATE TECHNOLOGY	150,151	129 INES GMBH	356	329 CSI	227	* ALLEN SYSTEMS	364
260 SEAGATE TECHNOLOGY	150,151	132 INTEGRAND RESEARCH	326	101 FOX SOFTWARE	109	22 ATRONICS INT'L. INC.	217
293 TIGERTRONICS	158	134 I.C. EXPRESS	362	192 NANTUCKET	39	26 BINARY TECHNOLOGY INC.	362
HARDWARE PROGRAMMERS							
19 APROTEK	356	330 KOH-I-NOOR RAPIDOGRAPH	243	193 NANTUCKET	39	48 CLUB AT	34,35
33 BP MICROSYSTEMS	370	175 MERRITT COMP. PRODS.	354	214 PATTON & PATTON	18	SYSTEMS	
34 BYTEK CORPORATION	172	191 M-S CORP.	356	221 PECAN SOFTWARE SYSTEMS	108	340 ADVANCED LOGIC RESEARCH	313
36 B & C MICROSYSTEMS	349	202 OMNITRONIX INC.	366	* RAIMA CORP.	16	341 ADVANCED LOGIC RESEARCH	313
37 B & C MICROSYSTEMS	358	213 PAMCO	356	256 SBT CORPORATION	252	* ALLEN SYSTEMS	364
154 LINK COMP. GRAPHICS	366	222 PERMA POWER ELECTRONICS	196	258 SCR CORPORATION	349	22 ATRONICS INT'L. INC.	217
155 LOGICAL DEVICES	70	223 PERMA POWER ELECTRONICS	196	281 SUPERSSELL SOFTWARE INC.	33	26 BINARY TECHNOLOGY INC.	362
156 LOGICAL DEVICES	70	251 ROSE ELECTRONICS	366	296 TRIGGS DATA SYSTEMS INC.	90	26 BINARY TECHNOLOGY INC.	362
INSTRUMENTATION							
* COMPUTER CONTINUUM	352	278 SUNCOAST SYSTEMS INC.	84	PRINTERS/PLOTTERS			
348 EI & S.	366	279 SUNCOAST SYSTEMS INC.	84	11 ALPS AMERICA	65,67	11 ALPS AMERICA	65,67
88 ELEXOR INC.	356	282 SWISSCOMP INC.	354	12 ALPS AMERICA	65,67	12 ALPS AMERICA	65,67
147 KEITHLEY/DAC	24	291 TELEX COMMUNICATIONS	228	* AST RESEARCH	128A1-6	* GALACTICOMM INC.	248
151 LAWSON LABS	358	292 TELEX COMMUNICATIONS	228	40 CANON U.S.A.	196	286 TALKING TECHNOLOGY	352
208 ORION INSTRUMENTS	220	294 TIGERTRONICS	362	41 CANON U.S.A.	197	NETWORK HARDWARE	
239 QUA TECH	312	6 UPS-DEPOT	370	44 CENTRAL COMPUTER PROD.	366	76 DIGITAL PRODUCTS	26
242 QUA TECH	312	305 VICTORY ENTERPRISES	197	47 CITIZEN AMERICA	17	* GALACTICOMM INC.	248
244 QUA TECH	312	MODEMS/MULTIPLEXORS				40 CANON U.S.A.	197
250 REAL TIME DEVICES	352	* CLEO SOFTWARE	298	44 CENTRAL COMPUTER PROD.	366	41 CANON U.S.A.	197
		* CODEX CORPORATION	122	47 CITIZEN AMERICA	17	44 CENTRAL COMPUTER PROD.	366
		324 FOSTER TECHNOLOGY	364	70 C. ITOH	234	47 CITIZEN AMERICA	17
		131 INTECTRA	318	71 C. ITOH	234	70 C. ITOH	234
		240 QUA TECH	352	75 DICONIX	100	71 C. ITOH	234
		241 QUA TECH	312	83 DRESSSELHAUS COMP. PROD.	120	75 DICONIX	100
		243 QUA TECH	312	93 FACIT AB	159	83 DRESSSELHAUS COMP. PROD.	120
				108 GENICOM	237	93 FACIT AB	159
				123 HEWLETT-PACKARD	206	108 GENICOM	237
				127 HOUSTON INSTR./AMETEK	27	123 HEWLETT-PACKARD	206
				198 LASERPRO	186	127 HOUSTON INSTR./AMETEK	27
				199 LASERPRO	186	198 LASERPRO	186
				197 NEC INFORMATION SYS.	CIII	199 LASERPRO	186
				201 OLYMPIA U.S.A. INC.	75	197 NEC INFORMATION SYS.	CIII
				216 PCPI	49	201 OLYMPIA U.S.A. INC.	75
				217 PCPI	49	216 PCPI	49
				276 STAR MICRONICS	185	217 PCPI	49
				* TOSHIBA AMERICA INC.	8,9	276 STAR MICRONICS	185
						* TOSHIBA AMERICA INC.	8,9
				SCANNERS/DIGITIZERS			
				95 FLAGSTAFF ENGINEERING	288	SCANNERS/DIGITIZERS	
				96 FLAGSTAFF ENGINEERING	288	95 FLAGSTAFF ENGINEERING	288
				SYSTEMS			
				340 ADVANCED LOGIC RESEARCH	313	SYSTEMS	
				341 ADVANCED LOGIC RESEARCH	313	340 ADVANCED LOGIC RESEARCH	313
				* ALLEN SYSTEMS	364	341 ADVANCED LOGIC RESEARCH	313
				22 ATRONICS INT'L. INC.	217	* ALLEN SYSTEMS	364
				26 BINARY TECHNOLOGY INC.	362	22 ATRONICS INT'L. INC.	217
				48 CLUB AT	34,35	26 BINARY TECHNOLOGY INC.	362
						48 CLUB AT	34,35

READER SERVICE

Advertising Supplements included with this issue:
Priority One Electronics (US Subscribers)
Computer Mail Order/CMO (Selected US Subscribers only.)

Inquiry No.	Page No.	Inquiry No.	Page No.	Inquiry No.	Page No.	Inquiry No.	Page No.
IBM/MS-DOS APPLICATIONS—							
Miscellaneous							
334 AD LIB INC.	323	162 LOGITECH	63	64 COMPUTER VALLEY	359	335 QUANTUM SOFTWARE LTD.	136
87 ECOSOFT	332	163 LOGITECH	63	65 COMPUTER WAREHOUSE	224	299 T & T COMPUTER PROD.	358
277 SUBLOGIC CORP.	51	167 MARK WILLIAMS CO.	20	66 COMPUTER WAREHOUSE	224	310 WENDIN INC.	238
IBM/MS-DOS APPLICATIONS—							
Scientific/Technical							
149 LABORATORY TECHNOLOGY	175	168 MARK WILLIAMS CO.	21	78 DISKCOTECH	356	311 WENDIN INC.	238
164 MACMILLAN SOFTWARE CO.	29	* MICROSOFT CORP.	56,57	79 DISKETTE CONNECTION	349		
170 MARKENRICH CORPORATION	362	182 MICROSOFT CORP.	64B1-4	58 DISKMASTER	352		
225 PERSONAL TEX	92	180 MICROSOFT CORP.	69	84 DYNAMIC ELECTRONICS CO.	366		
248 QUINN-CURTIS	352	181 MICROSOFT CORP.	69	99 FORTRON CORPORATION	250		
252 ROYAL AMERICAN TECHN.	308	* MICROSOFT CORP.	179	110 GLOBAL COMP. SUPPLIES	349		
344 SCIENCE & ENGINEERING SAW	361	* MICROSOFT CORP.	286	* HARMONY COMPUTERS	30		
274 SPECTRUM SOFTWARE	213	180 MIX SOFTWARE	105	135 JADE COMPUTER	368,369		
298 TURBOPOWER SOFTWARE	292	253 RYAN MCFARLAND CORP.	191	136 JAMECO ELECTRONICS	346,347		
IBM/MS-DOS—CAD							
17 AMERICAN SMALL BUSN. COMP.	91	IBM/MS-DOS—UTILITIES					
23 AUTOSKETCH INC.	261	21 ATRON CORPORATION	259	21 JDR MICRODEVICES	371		
39 CAD SOFTWARE	335	52 COMPACT DISC PRODS. INC.	202	139 JDR MICRODEVICES	372,373		
106 GENERIC SOFTWARE	315	329 CSI	227	140 JDR MICRODEVICES	374,375		
107 GENERIC SOFTWARE	315	68 CUSTOM SOFTWARE	183	141 JDR MICRODEVICES	376,377		
236 PROTEUS TECHNOLOGY CORP.	55	111 GOLDEN BOW SYSTEMS	349	143 J & R MUSIC WORLD	226		
314 WINTEK CORP.	5	112 GOLDEN BOW SYSTEMS	364	171 MEAD COMPUTER	365		
IBM/MS-DOS COMMUNICATIONS							
82 DCS	364	122 HERSEY MICRO CONSULTING	314	173 MEGASOFT	358		
113 GRAFFPOINT	364	157 LOGICAL SYSTEMS CORP.	320	176 MICROCOM SYSTEMS	72		
115 HAYES MICROCOMP. PROD.	42,43	169 MARK WILLIAMS CO.	23	177 MICROPROCESSORS UNLTD.	364		
130 INNER LOOP SOFTWARE	354	228 PETER NORTON	41	178 MICROSERVE	176		
145 KEA SYSTEMS	350	229 PETER NORTON	41	179 MICROSERVE	176		
148 KORTEK	96,97	230 PETER NORTON	274,275	184 MICROWAY	114		
287 SOFTKLONE DISTRIBUTING	242	231 PETER NORTON	274,275	* MICROWAY	270		
269 SOFTRONICS	320	* QUAD SOFTWARE	86	185 MINORITY HIGH TECH IND.	300		
325 SOFTWARE LINK, THE	25	264 SOFTCRAFT INC. (TX)	31	232 PINECOM COMPUTER INC.	359		
326 SOFTWARE LINK, THE	25	270 SOFTWARE DVLPMNT. SYS.	290	152 PROGRAMMER'S PARADISE	88,89		
312 WHITE CRANE SYSTEMS	90	272 SOLUTION SYSTEMS	294	234 PROGRAMMER'S SHOP	291		
IBM/MS-DOS—GRAPHICS							
104 FTG DATA SYSTEMS	366	312 WHITE CRANE SYSTEMS	90	336 PROG'S. SHOP/STERLING CAS.	293		
172 MEDIA CYBERNETICS	77	OTHER—LANGUAGES					
IBM/MS-DOS—LAN							
165 MANX SOFTWARE SYSTEMS	121	342 BASIS INC.	327	262 SILICON SPECIALTIES	87		
166 MANX SOFTWARE SYSTEMS	169	343 BASIS INC.	327	263 SILICON SPECIALTIES	87		
IBM/MS-DOS—LANGUAGES							
352 ALSYS LTD.	10,11	86 ECHELON	82	* SOFTLINE CORPORATION	95		
238 ARITY CORPORATION	85	103 FHL	370	283 S'NW ELECTRONICS	184		
24 AVOCET SYSTEMS INC.	208	165 MANX SOFTWARE SYSTEMS	121	284 S-100 DIV. 696 CORP.	355		
31 BORLAND INT'L	303	166 MANX SOFTWARE SYSTEMS	169	285 S-100 DIV. 696 CORP.	355		
32 BORLAND INT'L	303	300 UNIVERSAL CROSS-ASSEMBLERS	354	295 TIMELINE	348		
77 DIGITAL INC.	93	OTHER—UTILITIES					
87 ECOSOFT	332	* AMPRO COMPUTER INC.	201	297 TRI-STATE COMPUTER	344		
89 ELLIS COMPUTING	299	86 ECHELON	82	308 WAREHOUSE DATA	71		
103 FHL	370	103 FHL	370	DESKTOP PUBLISHING			
150 LATTICE INC.	44	165 MANX SOFTWARE SYSTEMS	121	4 ADOBE	203		
153 LIFEBOAT ASSOCIATES	207	166 MANX SOFTWARE SYSTEMS	169	158 LOGITECH	59		
		300 UNIVERSAL CROSS-ASSEMBLERS	354	159 LOGITECH	59		
		MAIL ORDER/RETAIL					
		5 ADVANCED COMP. PROD.	357	160 LOGITECH	61		
		* AMER. DESIGN COMPONENTS	363	161 LOGITECH	61		
		16 AMERICAN SEMICONDUCTOR	319	* LOTUS DEVELOPMENT	78,79		
		18 APPLIED MICRO TECH	354	* LOTUS DEVELOPMENT	139		
		* BUYER'S MART	336-344	265 SOFTCRAFT INC. (WI)	98		
		* CALIFORNIA DIGITAL	353	266 SOFTCRAFT INC. (WI)	98		
		53 COMPETITIVE EDGE	160	OPERATING SYSTEMS			
		54 COMPUSAVE	345	144 KADAK PRODUCTS LTD.	362		
		60 COMPUTER FRIENDS	360				
		* COMP. MAIL ORDER	161A1-12				
		62 COMPUTER PARTS GALORE	296				
		63 COMPUTER SURPLUS STORE	362				

ON-LINE SERVICES

425 BIX	284
450 BIX/MICROBYTES	285
55 COMPUSERVE	297
* DOW JONES NEWS/RETRIEVAL	309
273 SOURCE ELECTRONICS	94

EDUCATIONAL/ INSTRUCTIONAL

* BYTE BACK ISSUES	360
351 BYTE BITS	370
* BYTE CIRCULATION	331
* BYTE MARKETING	334
* BYTE SUB MESSAGE	207
* BYTE SUB. SERVICE	292
59 COMPUTER BOOK CLUB	273
* MCGRAW-HILL NRI SCHOOLS	321
209 OSBORNE/MCGRAW-HILL	244
210 OSBORNE/MCGRAW-HILL	311

MISCELLANEOUS

7 ALBERTO-CULVER CO.	22
8 ALF PRODUCTS	94
* ANTHRO CORP.	14
* BEST WESTERN	120
* BUSINESS WEEK	276
35 B & B ELECTRONICS	352
38 B & C MICROSYSTEMS	370
* CITICORP/DINER'S CLUB	167
347 DATA BUREAU	366
114 GRAND UNION MICRO SYS.	350
346 INTERFACE GROUP	316
* MCGRAW-HILL INFO. SERVICE	304,305
200 OFFICE & COMP. SUPPLIES INC.	354
345 ONLINE ACCESS	262
254 SAFEWARE	358
289 TDK ELECTRONICS CORP.	103
* TINNEY, ROBERT GRAPHICS	279
* TINNEY, ROBERT GRAPHICS	333
* TINNEY, ROBERT GRAPHICS	380

RECRUITMENT

* MOTOROLA SEMICONDUCTOR 218,219

* Correspond directly with company.

DON'T WASTE TIME WITH DESKTOP PUBLISHING.



You won't have to with our new Silentwriter™ LC890 page printer.

It's the desktop publishing printer with more than twice as much memory as an Apple® Laserwriter,™ for example. Which means it puts information together faster—and saves valuable minutes every time you create a new page of graphics or text. And the more complex the page, the more time saved.

The Silentwriter LC890 is also one of the least expensive printers that uses Adobe PostScript® page description language. Which lets you combine text, line art, and even digitized photographs on the same page.

Of course, you may not need all this pizzazz for

your printed pages. Then you should look into our Silentwriter LC860 Plus or our Silentwriter LC850, which are ideal for text and less complex graphics applications.

Our Silentwriter series will also keep you from wasting time with breakdowns and service. Because every Silentwriter printer has a life of about 600,000 pages—more than twice as much as ordinary lasers.

So if you want to make the most out of desktop publishing, don't waste a minute. Call 1-800-343-4418 (in MA 617-264-8635). Or write: NEC Information Systems, Dept. 1610, 1414 Massachusetts Ave., Boxborough, MA 01719.

**NEC PRINTERS. THEY ONLY STOP
WHEN YOU WANT THEM TO.**

C&C Computers and Communications

NEC

NEC Information Systems, Inc.

Inquiry 197

Tandy Computers:
Because there is
no better value.TM

The New Tandy[®] 4000

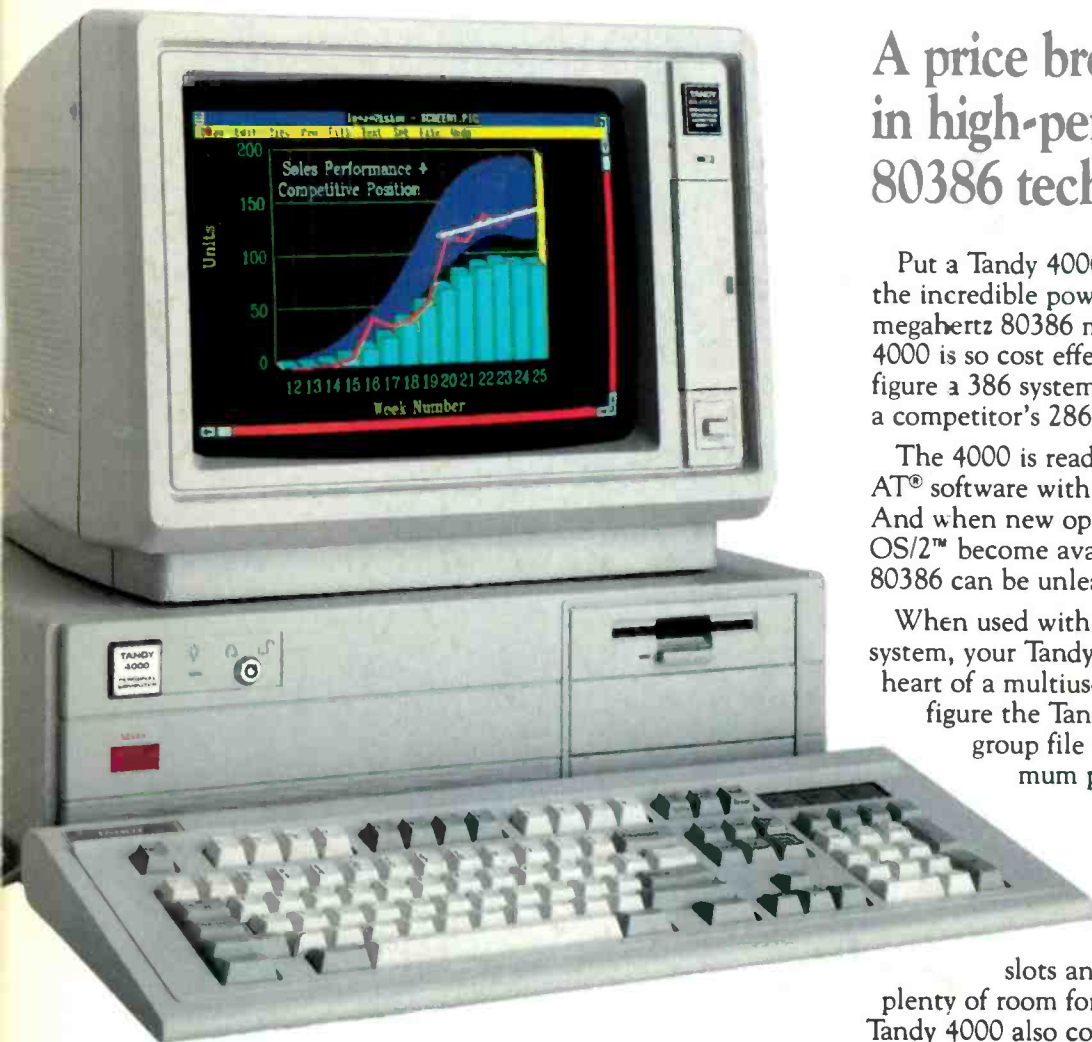

A price breakthrough
in high-performance
80386 technology.

Put a Tandy 4000 on your desk and unleash the incredible power of the 32-bit, 16-megahertz 80386 microprocessor. Our Tandy 4000 is so cost effective you can actually configure a 386 system for less than you'd pay for a competitor's 286 model.

The 4000 is ready to run current PC and AT[®] software with incredible new speed. And when new operating systems such as OS/2[™] become available, the full potential of 80386 can be unleashed.

When used with the XENIX[®] operating system, your Tandy 4000 can become the heart of a multiuser office system. Or configure the Tandy 4000 as a 3Com[®] work-group file server to achieve maximum productivity.

A built-in, high-capacity 3 1/2" disk drive lets you store up to 1.4 million characters on pocket-sized diskettes. Six AT slots and two XT[™] slots give you plenty of room for system expansion. The Tandy 4000 also comes with serial and parallel ports, a 101-key enhanced keyboard, and a keylock with chassis-lock mechanism for system protection.

Come into your local Radio Shack Computer Center today and see the new Tandy 4000—only \$2599. (25-5000)

Radio Shack[®]
COMPUTER CENTERS

A DIVISION OF TANDY CORPORATION

Inquiry 249

Price applies at Radio Shack Computer Centers and participating stores and dealers. Monitor, video display and operating systems sold separately. XENIX/Reg. TM and OS/2/™ Microsoft Corp. 3Com/Reg. TM 3Com Corp. AT/Reg. TM and XT/™ IBM.