

# BYTE

THE SMALL SYSTEMS JOURNAL

APRIL 1985 VOL. 10, NO. 4

\$3.50 IN UNITED STATES  
\$4.25 IN CANADA / £2.10 IN U.K.  
A MCGRAW-HILL PUBLICATION  
0360-5280

## ARTIFICIAL INTELLIGENCE

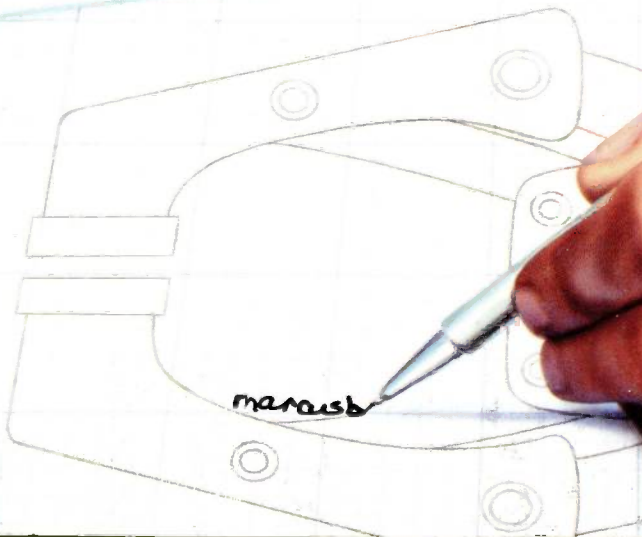



# Introducing The All you have to



You can also add other printers besides LaserWriter to The Macintosh Office. Including our stand-alone ImageWriter printer you see here, as well as letter-quality daisywheel printers you don't see here.

The LaserWriter printer has its own built-in type styles and sizes, and it can be shared by everyone in The Macintosh Office.

Right now, IBM PC's can use our new LaserWriter printer. Later this year, we'll be introducing the AppleTalk card that fits into an IBM PC, allowing it to trade information with Macintosh and access file servers. As well as serve as a gateway between the IBM PC network and our AppleTalk network.

The AppleLine protocol converter lets you talk directly to your mainframe via 3270 emulation.

Our entry-level workstation in The Macintosh Office is, naturally enough, the Macintosh 128K.

\* Manufacturer's suggested retail price © 1985 Apple Computer, Inc. Apple, the Apple logo, AppleTalk and ImageWriter are trademarks of Apple Computer, Inc. Macintosh is a trademark licensed to Apple Computer, Inc. Microsoft is a registered trademark of Microsoft Corporation. ThinkTank is a trademark of Living Videotext Inc. Jazz and Lotus are trademarks of Lotus Development Corporation. IBM is a registered trademark of International Business Machines Corporation. For an authorized Apple dealer nearest you call (800) 538-9696. In Canada, call (800) 268-7796 or (800) 268-7637.



# Macintosh Office. add is people.



Macintosh XL, up to a full megabyte of RAM and a built-in 10 MB hard disk.

No, not computer systems people to help you design it. Or computer experts to show you how to use it.

But the kind of people who already make up most of your office.

Managers and professionals. People who spend most of their time selling products, services or, most importantly, ideas.

Because, unlike traditional office computer solutions, we didn't design The Macintosh™ Office around a mainframe. We designed it around an idea.

The idea that people, not mainframes, are the most important information centers in an office. And that most things in business are really accomplished by teams of 5 to 25 people who need to share information with each other. What we call the *workgroup*.

That's why we put Macintosh at the heart of The Macintosh Office. Its powerful, 32-bit technology reduces the time it takes to become productive with a computer from well over a work week, to just under a lunch hour.

For the first time, the people who could really use a computer — managers and professionals — had a computer they could really use. In their choice of sizes: Macintosh 128K, Macintosh 512K and Macintosh XL.

Then we designed a network solution for workgroups of 5 to 25. Instead of buildings of 500 to 2,500.

We call it the AppleTalk™ Personal Network. It's as easy to hook together as an extension cord. And almost as cheap. Less than \$50\* a desk, versus up to \$1,200 for a typical network system.

Since the number one product of business is still paper, we found a way to make every sheet count. A breakthrough in printed communications called the LaserWriter printer. It produces publication-quality text and graphics. Making your

presentations, reports and overheads more persuasive.

We've even found a way for The Macintosh Office to share offices with IBM.® An AppleTalk card that slips into an IBM PC, allowing it to trade information with Macintosh and access file servers.

Third party developers are also working on The Macintosh Office. Next month,

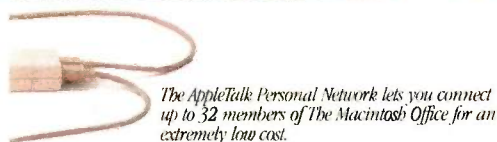

The AppleTalk Personal Network lets you connect up to 32 members of The Macintosh Office for an extremely low cost.

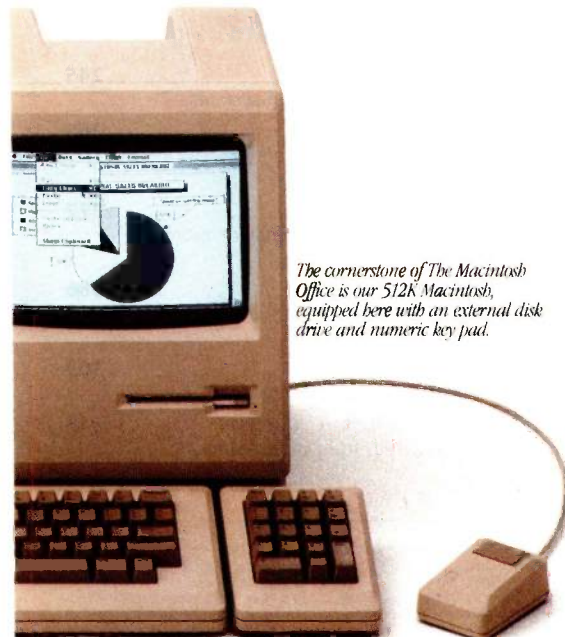

The cornerstone of The Macintosh Office is our 512K Macintosh, equipped here with an external disk drive and numeric key pad.



Our LaserWriter produces publication-quality text and graphics.

they'll be offering shared storage devices that let your workgroup share information. And they're writing a whole new generation of business software to go along with the 350 programs Macintosh already runs. Including Microsoft® Word, ThinkTank™ 512 and the new Jazz™ from Lotus.®

Now, there's only one more thing we'd like to add to this ad: call 800-446-3000.

We'll tell you how to get everything you need to turn your office into a Macintosh Office.

People not included.





# C·O·N·T·E·N·T·S



100

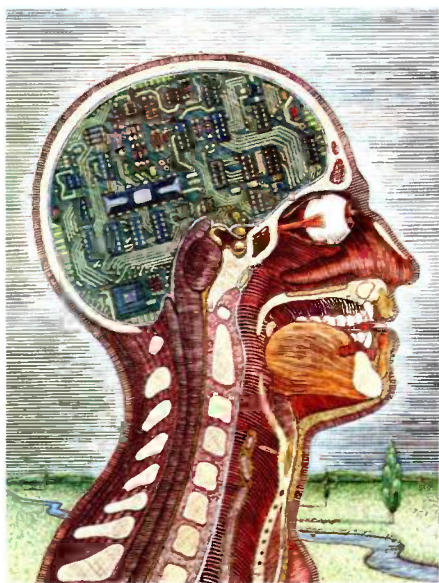

124

## FEATURES

- INTRODUCTION** ..... 100
- CIARCIA'S CIRCUIT CELLAR: BUILD THE HOME RUN CONTROL SYSTEM**  
**PART I: INTRODUCTION** *by Steve Ciarcia* ..... 102  
 Steve returns to the field of home control in this first part of a three-part series.
- COPROCESSING IN MODULA-2** *by Colleen Roe Wilson* ..... 113  
 This method lets you cooperatively process information by interleaved execution on a single computer.
- A MILLION-POINT GRAPHICS TABLET** *by James Hawley* ..... 120  
 Build a graphics pad for less than \$200 using the KoalaPad for input.

## THEMES

- INTRODUCTION** ..... 124
- COMMUNICATION WITH ALIEN INTELLIGENCE** *by Marvin Minsky* ..... 126  
 It may not be as difficult as you would think.
- THE QUEST TO UNDERSTAND THINKING**  
*by Roger Schank and Larry Hunter* ..... 143  
 It begins not with complex issues but with the most trivial of processes.
- THE LISP TUTOR** *by John R. Anderson and Brian I. Reiser* ..... 159  
 The system described offers many of the advantages of a human tutor in teaching LISP programming.
- PROUST** *by W. Lewis Johnson and Elliot Soloway* ..... 179  
 This LISP program automatically debugs the efforts of novice Pascal programmers.
- ARCHITECTURES FOR AI** *by Michael F. Deering* ..... 193  
 The right combination of hardware and software is necessary for efficient processing.
- THE LISP REVOLUTION** *by Patrick H. Winston* ..... 209  
 The language is no longer limited to a lucky few.
- THE CHALLENGE OF OPEN SYSTEMS** *by Carl Hewitt* ..... 223  
 Current logic programming methods may be insufficient for developing the intelligent systems of the future.
- VISION** *by Dana H. Ballard and Christopher M. Brown* ..... 245  
 Technology is still being challenged to create reliable real-time vision systems.
- LEARNING IN PARALLEL NETWORKS** *by Geoffrey E. Hinton* ..... 265  
 The author presents two theories of how learning could occur in brain-like networks.
- CONNECTIONS** *by Jerome A. Feldman* ..... 277  
 Massively parallel computational models may simulate intelligent behavior more closely than models based on sequential machines.
- REVERSE ENGINEERING THE BRAIN** *by John K. Stevens* ..... 286  
 The brain's circuitry can serve as a model for silicon-based designs.
- THE TECHNOLOGY OF EXPERT SYSTEMS**  
*by Robert H. Michalsen, Donald Michie, and Albert Boulanger* ..... 303  
 There's more than one way to transplant expert knowledge to machines.
- INSIDE AN EXPERT SYSTEM** *by Beverly A. Thompson and William A. Thompson* ..... 315  
 The authors trace the development of a rule-based system from index cards to a Pascal program.

BYTE (ISSN 0360-5280) is published monthly by McGraw-Hill Inc. Founder: James H. McGraw (1860-1948). Executive, editorial, circulation, and advertising offices: 70 Main St., Peterborough, NH 03458; phone (603) 924-9281. Office hours: Mon-Thur 8:30 AM-4:30 PM; Friday 8:30 AM-1:00 PM; Eastern Time. Address subscriptions to BYTE Subscriptions, POB 590, Martinsville, NJ 08836. Postmaster: send address changes: USPS Form 3570, undeliverable copies and fulfillment questions to: BYTE Subscriptions, POB 596, Martinsville, NJ 08836. Second-class postage paid at Peterborough, NH 03458 and additional mailing offices. Postage paid at Winnipeg, Manitoba. Registration number 9321. Subscriptions are \$21 for one year, \$38 for two years, and \$55 for three years in the USA and its possessions. In Canada and Mexico \$23 for one year, \$42 for two years, \$61 for three years, \$69 for one year air delivery to Europe, 17,100 yen for one year surface delivery to Japan, \$37 surface delivery elsewhere. Air delivery to selected areas at additional rates upon request. Single copy price is \$3.10 in the USA and its possessions, \$3.95 in Canada and Mexico, \$4.50 in Europe, and \$5 elsewhere. Foreign subscriptions and sales should be remitted in United States funds drawn on a US bank. Please allow six to eight weeks for delivery of first issue. Printed in the United States of America.



## REVIEWS

<b>INTRODUCTION</b> .....	<b>334</b>
<b>REVIEWER'S NOTEBOOK</b> by Glenn Hartwig .....	<b>337</b>
<b>THE ITT XTRA</b> by John D. Unger .....	<b>338</b>
An IBM PC-compatible system with telecommunications software.	
<b>INSIGHT—A KNOWLEDGE SYSTEM</b> by Bruce D'Ambrosio .....	<b>345</b>
Software to help you build an expert system and learn about artificial intelligence.	
<b>REVIEW FEEDBACK</b> .....	<b>348</b>
Readers respond to previous reviews.	

## KERNEL

<b>INTRODUCTION</b> .....	<b>353</b>
<b>COMPUTING AT CHAOS MANOR: OVER THE MOAT</b> by Jerry Pournelle .....	<b>355</b>
As construction workers descend on Chaos Manor, Jerry battles the flu to look at more new items.	
<b>CHAOS MANOR MAIL</b> conducted by Jerry Pournelle .....	<b>373</b>
Jerry's readers write, and he replies.	
<b>BYTE WEST COAST: LASERS, OFFICE PUBLISHING, AND MORE</b> by John Markoff and Phillip Robinson .....	<b>379</b>
Our West Coast editors report on Interleaf's OPS-2000 and TPS-2000 and on FastFinder for the Macintosh.	
<b>BYTE U.K.: NEW DATABASE IDEAS</b> by Dick Pountain .....	<b>389</b>
I.D.E.A.S. is a commercial database-generator package in which all data items are related by a system of coordinates abstracted from the real world.	
<b>BYTE JAPAN: THE FIFTH GENERATION IN JAPAN</b> by William M. Raike .....	<b>401</b>
Our Japan correspondent takes note of the International Conference of Fifth Generation Computer Systems, the new Hitachi supercomputer, and software development in the country.	
<b>CIRCUIT CELLAR FEEDBACK</b> conducted by Steve Ciarcia .....	<b>408</b>
Steve answers project-related queries from readers.	

EDITORIAL: GOLFERS AND HACKERS .....	<b>6</b>	EVENT QUEUE .....	<b>83</b>
MICROBYTES .....	<b>9</b>	WHAT'S NOT .....	<b>96</b>
LETTERS .....	<b>14</b>	BOOKS RECEIVED .....	<b>414</b>
FIXES AND UPDATES .....	<b>33</b>	PROGRAMMING INSIGHT .....	<b>429</b>
WHAT'S NEW .....	<b>39, 440</b>	UNCLASSIFIED ADS .....	<b>493</b>
ASK BYTE .....	<b>48</b>	BYTE'S ONGOING MONITOR BOX, BOMB RESULTS .....	<b>494</b>
CLUBS & NEWSLETTERS .....	<b>58</b>	READER SERVICE .....	<b>495</b>
BOOK REVIEWS .....	<b>65</b>		

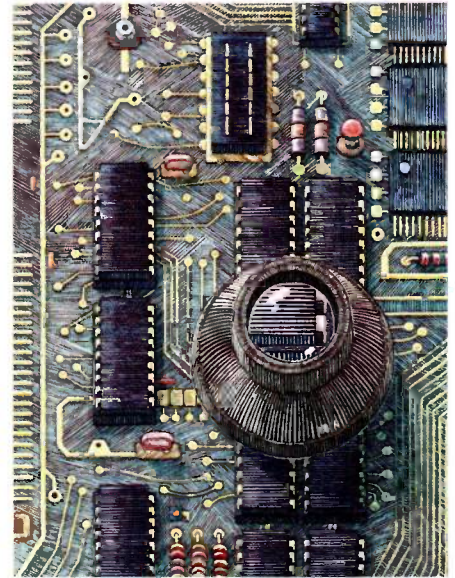

334

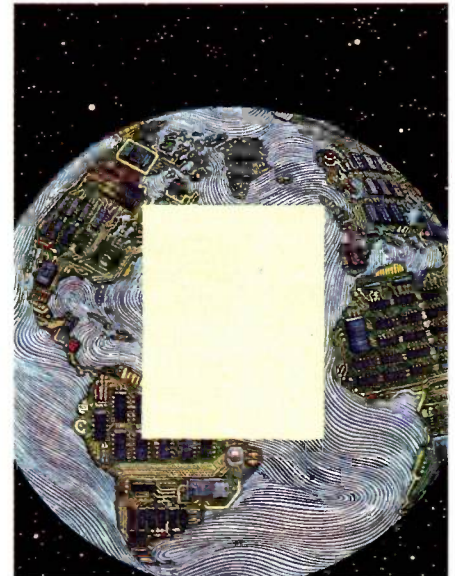

353

Address all editorial correspondence to the Editor, BYTE, POB 372, Hancock, NH 03449. Unacceptable manuscripts will be returned if accompanied by sufficient first-class postage. Not responsible for lost manuscripts or photos. Opinions expressed by the authors are not necessarily those of BYTE. Copyright © 1985 by McGraw-Hill Inc. All rights reserved. Trademark registered in the United States Patent and Trademark Office. Where necessary, permission is granted by the copyright owner for libraries and others registered with the Copyright Clearance Center (CCC) to photocopy any article herein for the flat fee of \$1.50 per copy of the article or any part thereof. Correspondence and payment should be sent directly to the CCC, 29 Congress St., Salem, MA 01970. Specify ISSN 0360-5280/83 \$1.50. Copying done for other than personal or internal reference use without the permission of McGraw-Hill Inc. is prohibited. Requests for special permission or bulk orders should be addressed to the publisher. BYTE is available in microform from University Microfilms International, 300 North Zeeb Rd., Dept. PR, Ann Arbor, MI 48106 or 18 Bedford Row, Dept. PR, London WC1R 4EJ England. Subscription questions or problems should be addressed to: BYTE Subscriber Service, POB 328, Hancock, NH 03449





# MicroTime



800 - MICRO 84

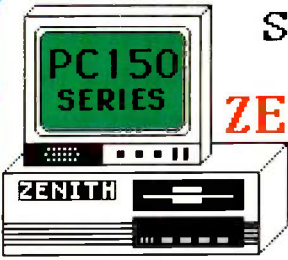

SAVE ON ZENITH

THE BEST IBM COMPATIBLE

PC 160 PORTABLE



SANYO COMPUTERS ALL MODELS AVAILABLE



FREE SOFTWARE

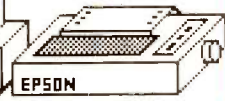

WE HAVE ALL EPSON PRINTERS IN STOCK AT LOW PRICES

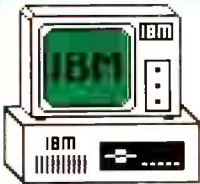

IBM PC



BERNOULLI BOX

20 MEGABYTE ULTRA FAST REMOVABLE STORAGE

CORVUS JUKI TOSHIBA

CITOH OKIDATA BROTHER DIABLO

WE SPECIALIZE IN SYSTEM SALES

CALL US FOR THE LOWEST PRICES ON ALL COMPUTER PRODUCTS

800-642-7684 IN ARIZONA 602-791-9030

IBM is a registered trademark of International Business Machines, Corp.

411 West Grant Road Tucson, Arizona 85705



# BYTE

**EDITOR IN CHIEF**

PHILIP LEMMONS

**MANAGING EDITOR**

GENE SMARTE

**CONSULTING EDITORS**

STEVE CIARCIA  
JERRY POURNELLE

**SENIOR TECHNICAL EDITORS**

G. MICHAEL VOSE, *Themes*  
GREGG WILLIAMS

**TECHNICAL EDITORS**

THOMAS R. CLUNE  
ION R. EDWARDS  
RICHARD GREHAN  
GLENN HARTWIG, *Reviews*  
RICHARD KRAIEWSKI  
KEN SHELDON  
RICHARD S. SHUFORD  
JANE MORRILL TAZELAAR  
EVA WHITE  
STANLEY WSZOLA

MARGARET COOK GURNEY, *Associate*

ALAN EASTON, *Drafting*

**WEST COAST EDITORS**

EZRA SHAPIRO, *Bureau Chief, San Francisco*  
JOHN MARKOFF, *Senior Technical Editor, Palo Alto*  
PHILLIP ROBINSON, *Senior Technical Editor, Palo Alto*  
DONNA OSGOOD, *Associate Editor, San Francisco*  
BRENDA McLAUGHLIN, *Editorial Assistant, San Francisco*

**NEW YORK EDITOR**

RICHARD MALLOY, *Senior Technical Editor*

**MANAGING EDITOR**

**ELECTRONIC PUBLISHING AND COMMUNICATIONS**

GEORGE BOND

**USER NEWS EDITOR, EAST COAST**

ANTHONY J. LOCKWOOD, *What's New*

**USER NEWS EDITOR, WEST COAST**

MARK WELCH, *Microbytes*

**CONTRIBUTING EDITORS**

DENNIS ALLISON, *at large*  
MARK DAHMKE, *video operating systems*  
MARK HAAS, *at large*  
RIK IADRNICIK, *CAD, graphics, spreadsheets*  
MARK KLEIN, *communications*  
ALAN MILLER, *languages and engineering*  
JOHN C. NASH, *scientific computing*  
DICK POUNTAIN, *U.K.*  
WILLIAM M. RAIKE, *Japan*  
PERRY SAIDMAN, *computers and law*  
ROBERT STERNE, *computers and law*  
BRUCE WEBSTER, *software*

**COPY EDITORS**

BUD SADLER, *Chief*  
DENNIS BARKER  
ELIZABETH COOPER  
ANNE L. FISCHER  
NANCY HAYES  
LYNNE M. NADEAU  
PAULA NOONAN  
JOAN VIGNEAU ROY  
WARREN WILLIAMSON

**ASSISTANTS**

PEGGY DUNHAM  
MARTHA HICKS  
BEVERLY JACKSON  
LISA JO STEINER

**ART**

ROSSLYN A. FRICK, *Art Director*  
NANCY RICE, *Assistant Art Director*

**PRODUCTION**

DAVID R. ANDERSON, *Production Director*  
DENISE CHARTRAND  
MICHAEL I. LONSKY  
JAN MÜLLER  
SHERRY MCCARTHY, *Chief Typographer*  
NAN FORNAL  
LEN LORETTE  
KATHY QUIST  
DONNA SWEENEY

**SENIOR VICE PRESIDENT PUBLISHER**

HARRY L. BROWN  
**ASSISTANT PUBLISHER**  
MICHELE P. VERVILLE  
**PUBLISHER'S ASSISTANT**  
DORIS R. GAMBLE  
**REPRINTS AND PERMISSIONS**  
FAITH A. KLUNTZ

**ADVERTISING SALES**

J. PETER HUESTIS, *Sales Manager*  
SANDRA FOSTER, *Administrative Assistant*

**ADVERTISING**

LISA WOZMAK, *Supervisor*  
ROBERT D. HANNINGS, *Senior Account Manager*  
MARION CARLSON  
KAREN CILLEY  
LYDA CLARK  
MICHELE GILMORE  
DENISE PROCTOR

**ADVERTISING/PRODUCTION**

WAI CHIU LI, *Quality Control Director*  
JULIE NELSON, *Advertising/Production Coordinator*  
LINDA J. SWEENEY, *Advertising/Production Coordinator*

**CIRCULATION**

GREGORY SPITZFADEN, *Director*  
ANDREW JACKSON, *Subscriptions Manager*  
CATHY A. R. DREW, *Assistant Manager*  
LAURIE SEAMANS, *Assistant Manager*  
SUSAN BOYD  
PHIL DECHERT  
MARY EMERSON  
LOUISE MENEGUS  
AGNES E. PERRY  
JENNIFER PRICE  
JAMES BINGHAM, *Single-Copy Sales Manager*  
LINDA RUTH, *Assistant Manager*  
CAROL AHO  
CLAUDETTE CARSWELL  
KAREN DESROCHES

**MARKETING COMMUNICATIONS**

HORACE T. HOWLAND, *Director*  
VICKI REYNOLDS, *Marketing Production Manager*  
PRISCILLA ARNOLD, *Marketing Assistant*  
STEPHANIE WARNESEY, *Marketing Art Director*  
SHARON PRICE, *Assistant Art Director*  
DOUG WEBSTER, *Director of Public Relations*  
WILBUR S. WATSON, *Operations Manager, Exhibits*  
PATRICIA AKERLEY, *Research Manager*  
CYNTHIA DAMATO SANDS, *Reader Service Coordinator*

**ACCOUNTING**

DANIEL RODRIGUES, *Business Manager/Controller*  
KENNETH A. KING, *Assistant Controller*  
VICKI WESTON, *Accounting Manager*  
LINDA SHORT, *DIP Manager*  
EDSON WARE, *Credit*  
MARIE CAGGIANI  
MARILYN HAIGH  
DIANE HENRY  
VERN ROCKWELL  
JOANN WALTER

**BUILDING SERVICES/TRAFFIC**

ANTHONY BENNETT, *Building Services Manager*  
BRIAN HIGGINS  
MARK MONKTON

**RECEPTIONISTS**

L. RYAN MCCOMBS  
CHERYL CASTRO, *Assistant*

**PERSONNEL**

CHERYL A. HURD, *Office Manager*  
PATRICIA BURKE, *Personnel Coordinator*

**BYTE BUSINESS PHONES**

PETE HUESTIS, 603-924-6137; HORACE HOWLAND, 603-924-3424  
DOUG WEBSTER, 603-924-9027; BRAD BROWNE, 603-924-6166  
ADVERTISING, 603-924-6448; CIRCULATION, 800-258-5485

**Editorial and Business Office:** 70 Main Street, Peterborough, New Hampshire 03458 (603) 924-9281.

**West Coast Offices:** McGraw-Hill, 425 Battery St., San Francisco, CA 94111, (415) 362-4600.

McGraw-Hill, 1000 Elwell Court, Palo Alto, CA 94303, (415) 964-0624.

**New York Office:** 1221 Avenue of the Americas, New York, NY 10020, (212) 512-2000.

Officers of McGraw-Hill Information Systems Company: President: Richard B. Miller; Executive Vice Presidents: Frederick P. Iannotti, Construction Information Group; Russell C. White, Computers and Communications Information Group; J. Thomas Ryan, Marketing and International Senior Vice Presidents; Francis A. Shinal, Controller; Robert C. Violette, Manufacturing and Technology; Senior Vice Presidents and Publishers: Harry L. Brown, Computers and Communications; David J. McGrath, Construction; Group Vice President: Peter B. McCuen, Communications; Vice Presidents: Fred O. Jensen, Planning and Development; Margaret L. Dagner, Human Resources.

Officers of the Corporation: Harold W. McGraw, Jr., Chairman; Joseph L. Dionne, President and Chief Executive Officer; Robert N. Landes, Senior Vice President and Secretary; Ralph J. Webb, Treasurer.



# CROMEMCO COMPUTERS: DESIGNED TO MAKE UNIX SYSTEM V EVEN BETTER...

UNIX System V, the new standard in multi-user microcomputer operating systems, gives you high performance features along with the portability and flexibility of a standard.

Cromemco computers can make UNIX System V even better. Because our systems are designed with UNIX in mind. First of all, we offer UNIX System V with Berkeley enhancements. Then, our hardware uses advanced features like 64K of on-board cache memory and our high speed STDC controller to speed up disk operations - very important with UNIX.

### **More capability and expandability**

We have a high-speed, 68000-based CPU that runs at 10 MHz, coupled with a memory manager that uses demand-paging and scatter loading to work with UNIX, not for it.

We provide room for expanding RAM to 16 megabytes - with error detection and correction - for running even the most sophisticated and advanced microcomputer programs. And the power to accommodate up to 16 users - all with plenty of memory.

But we give you even more.

### **A complete solution**

We give you a choice in systems: the System 100 series, expandable up to 4 megabytes of RAM, and the System 300 series, expandable to 16 megabytes. A high speed 50 megabyte hard disk drive is standard on the systems. And you can expand the hard disk capacity up to 1200 megabytes using standard SMD drives. You can add floating point processing. High resolution graphics. Video digitizing and imaging. Communications through

standard protocols. Mail frame interface.

And software support is here to meet your needs. We offer major programming languages, database management systems, communications software, including SNA architecture, X.25 protocol, and Ethernet; even a program to interface to an IBM PC if you need to. And, of course, access to the broad range of standard UNIX applications programs that is growing dramatically every day.

### **Easy to use.**

We also make our systems easier to use, because we install the operating system before we ship your computer. No complicated installation procedures. And the Berkeley enhancements give you the standard UNIX System V operating system, but with the added convenience of these widely acclaimed improvements.

Cromemco's System 100 and System 300 computers: designed to be the highest performance UNIX systems available anywhere.

Just call or visit one of our UNIX System V Official System Centers to see for yourself. They'll also give you a copy of our new publication, "What you should know before you buy a UNIX system." Or contact us directly.

We'll be glad to show you how to get a better UNIX system.

Corporate Headquarters: Cromemco, Inc.,  
280 Bernardo Avenue, P.O. Box 7400, Mountain  
View, CA 94039. (415) 969-4710. In Europe:

Cromemco  
GmbH, 6236  
Eschborn 1,  
Frankfurter Str.  
33-35, P.O. 5267,  
Frankfurt Main,  
Germany.



UNIX is a trademark of Bell Laboratories.  
IBM is a trademark of International Business Machines Corp.

**Cromemco**®



## GOLFERS AND HACKERS

It must no longer go unremarked that many of the criminals who threaten the foundations of our society are golfers. Golfers persist in attacking our personal, financial, and military security. Many golfers, like the famous one caught in the act in photo 1 (Spiro Agnew), have been involved in extortion, bribery, or other forms of corruption.

Some golfers have been known to hit out of bounds as a pretext for trespassing in residential communities. Such forays easily turn into incidents of voyeurism and burglary.

## VIOLENCE

Other golfers use the harmless-looking little white balls to inflict injuries on bystanders, propelling the dangerous projectiles at speeds in excess of 120 miles per hour. The danger of head injuries is obvious. Golf's careless disregard for the safety of other people hardens our children to violence. The idea that shouting a single, obscure word makes it all right to bop some innocent person on the head with a hard projectile has brought our society to the brink of savagery. Last week in a major American city a thug shouted "Fore!" and then mugged a grandmother as if it were the most natural thing in the world.

## GOLFING ARCADES

Perhaps the most distasteful thing about golfers is their use in recent years of golfing arcades. These so-called "driving ranges" allow addicts to rent baskets containing dozens or even hundreds of golf balls so that the addicts can bombard surrounding land at rates previously unthinkable. Although the fences sometimes used around these golfing dens may protect people outside from physical in-

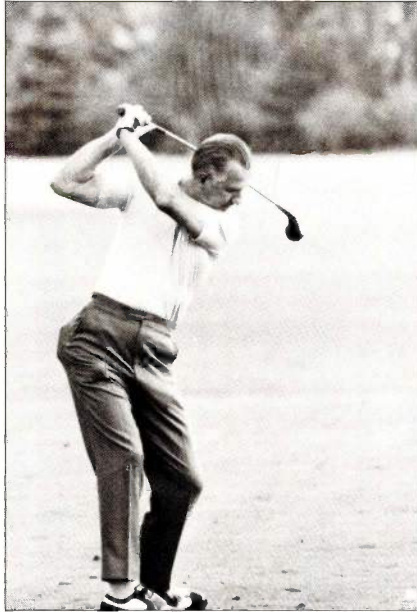

jury, the fences do nothing to stop the spread of the moral rot associated with the trancelike concentration of the golfer on the little white ball. That little ball means more to the golf addict than honor, mother, or country.

The money squandered at golfing arcades, golf courses, and pro shops could buy a personal computer for every child in America or pay off the national debt, depending on national priorities.

## NATIONAL SECURITY IMPLICATIONS

The parliament of King James II of 1457 banned golf because its addicts neglected to practice the use of the crossbow, then the chief means of national defense. Today in this country, golfers neglect the most advanced weapons systems in history. This neglect could nullify all the technical progress recently seen in weapons research. What good is an orbital-beam weapon if the operator is busy selecting a club?

It doesn't take a genius to see that avoidance of golf is a cornerstone of Soviet military strategy. This gives the Soviets a tremendous advantage in daytime warfare. If the Soviets launch an attack at 3 p.m. EST on a weekday in June, approximately 20 percent of American manpower will be uselessly deployed in fairways, sandtraps,

and rough. Even those in bunkers will be in the wrong kind of bunkers. At 3 p.m. on a weekend, as much as 50 percent of our manpower might be trying to avoid bogies rather than to shoot them down.

## CALL TO ACTION

Because of the threats that golfers pose to national security and our moral fiber, we are proposing that all golfers be arrested as soon as possible.

## UNFAIR?

If the foregoing attack on golfers seems unfair (and, of course, the analogy is not perfect), it is little more so than the attack in the general press on hackers of another kind—computer hackers. Some national publications have used the term "hacker" incorrectly as a synonym for "criminal." Hackers are people who play with computers at a technical level because they enjoy doing so. There are many thousands of hackers in North America. A few hackers use their computer skills for pranks, and fewer still use their skills to commit crimes. But the chances are excellent that far more hackers are helping build defenses around databases than trying to penetrate them. If even one percent of hackers started trying to invade our databases, problems would be far more serious than those sensationalized in the general press.

It wasn't being a golfer that got Spiro Agnew into trouble. Just being a hacker won't get anyone into trouble, either. Hackers are as entitled to the presumption of innocence as golfers and other common special-interest groups. Hackers are also entitled to the continued correct use of the authentic, distinctive, and colorful name that they gave themselves.

—Phil Lemmons, Editor in Chief





# Maxell Gold.

The 3 1/2" microdisk that gives Macintosh™ more to chew on and helps the HP® Touchscreen PC tap your deepest memories.

Whether you're in search of primeval wisdom, or polishing up financial projections, Maxell makes the Gold Standard microdisk for your computer. In fact, there's a Gold Standard for virtually every computer made. Maxell floppys are industry leaders in error-free performance. Each comes with a lifetime warranty. And each microdisk is perfectly compatible with your 3 1/2" drive.

**maxell.**  
IT'S WORTH IT.

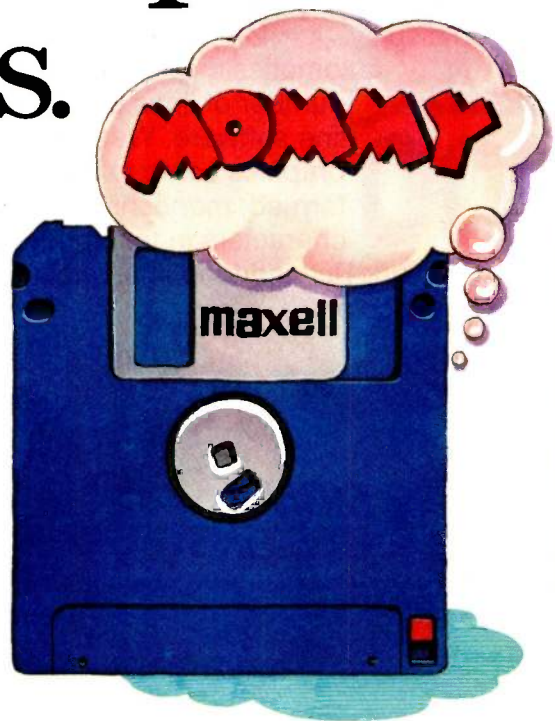

Macintosh is a trademark licensed to Apple Computer, Inc.

Maxell Corporation of America, 60 Oxford Drive, Moonachie, N.J. 07074



# Princeton Graphic Systems and Sigma Designs team up to give you a brighter, sharper display.

**SR-12 and Color 400. A brilliant combination for super-high resolution graphics and a crisp character display.** For a brighter, sharper display with all your IBM PC-compatible software here's a team that can't be beat. The SR-12 super-high resolution RGB monitor from Princeton Graphic Systems and Color 400, the advanced color graphics adapter card from Sigma Designs.



SR-12

**Turn on SR-12 for the impressive results.** The SR-12 displays your Color 400 image with unmatched clarity and brilliant color. Because the SR-12 combines a .31mm dot pitch tube and a non-glare screen with an incredible 640 x 400 non-interlaced resolution, you get a flickerless image that's as crisp and clean as a personal computer can produce.

**Snap in Color 400.** Begin by snapping Color 400 in to your IBM PC, XT, or AT. No switches to set. No cables to confuse. Color 400 gives you a razor sharp 640 x 400 display. It

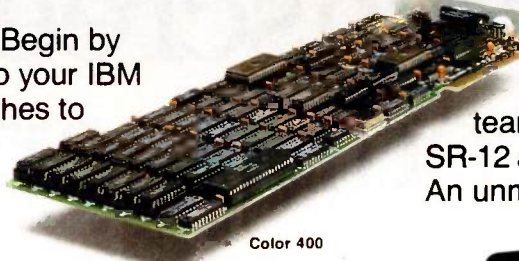

Color 400

See how impressive this state-of-the-art image can be on your own PC system. Visit your local retailer today and ask about this new color graphics team. Princeton Graphic System's SR-12 and Sigma Designs' Color 400. An unmatched, brilliant combination.

**COLOR 400**

automatically *doubles* the number of lines on standard 200 line software. Watch your graphics come to life. Enjoy fully formed, monochrome-quality characters in text mode. Just turn on your PC and tune in a whole new world of vibrant color.

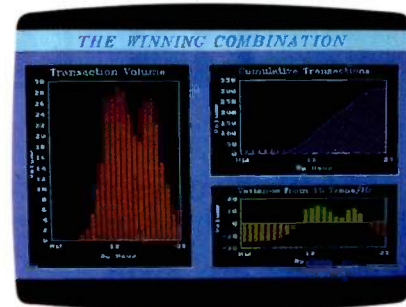

SIGMA DESIGNS, INC., 2023 O'Toole Avenue, San Jose, CA 95131  
(408) 943-9480 Telex: 171240



Princeton Graphic Systems, 601 Ewing Street, Bldg. A, Princeton, N.J. 08540  
(609) 683-1660, Telex: 821402 PGS PRIN, (800) 221-1490 Ext. 204



## ..... **Macintosh Users Get IBM PC Emulator** .....

Dayna Communications, Salt Lake City, UT, has announced MacCharlie, a hardware-and-software system that allows Macintosh users to run IBM PC software. Two hardware components are included: one adds 10 function keys and an 18-key numeric keypad/cursor pad to the Macintosh keyboard; the other has one or two 5¼-inch disk drives, memory, an IBM-compatible ROM chip, and an 8088 processor, as well as serial and parallel ports and a bus-extender port for an optional expansion chassis. Also included is a Macintosh program that handles all keyboard and display processing—and it can still be used to access the Mac's desk accessories from within IBM PC applications. MacCharlie emulates all features of the IBM monochrome graphics card except for light-pen support.

The Macintosh can be set atop the matching MacCharlie unit, which adds four inches to the Macintosh's width and one inch to its height. The Macintosh keyboard fits into the keyboard extender; the numeric keypad can be used as a standard Macintosh numeric keypad when in Macintosh mode. The bus-extender port allows use of an optional expansion chassis so that IBM cards can be installed; with an additional cable, IBM's expansion chassis can be used. With one 5¼-inch disk drive and 256K bytes of memory, MacCharlie is \$1195; with two drives and 640K, it's \$1895.

## ..... **New Mac Products Shown** .....

Several companies unveiled new products for the Macintosh at the MacWorld Expo in San Francisco. While many new software titles were demonstrated, memory-expansion and hard-disk-drive exhibits drew much attention.

Micro Conversion, Arlington, TX, and Levco Enterprises, Del Mar, CA, both offer complete 512K-byte upgrades for \$400, including installation, and also sell uninstalled kits. Levco also sells a \$60 kit with all necessary parts except the 256K-byte chips.

In addition to already-announced hard-disk products, new drives from Paradise Systems Inc. and Micro-Design were shown in prototype form. Not surprisingly, most exhibitors used hard disks and 512K-byte Macs to demonstrate their software.

Hayden Software showed Ensemble, an integrated package for the 128K-byte Mac. Database, spreadsheet, graphics, and text-processing features are included in the \$300 program, which was developed in France. A number of new database programs were also exhibited at the show.

Paragon Courseware, Del Mar, CA, offers two font sets: a \$50 Scientific Typing font and a \$100 Electronic Circuits font.

Micro Focus Inc. now offers MacCOBOL, a COBOL development system.

## ..... **Microsoft Releases Its Own C Compiler** .....

Microsoft has released Microsoft C version 3.0, which replaces the Lattice-developed C previously sold by Microsoft for the IBM PC. Microsoft's C compiler provides file-sharing and record-locking features for use in network environments; a separate Windows Toolkit will help C programmers develop applications to run under Microsoft Windows. Microsoft says that source and object code can be linked to run directly under MS-DOS or XENIX without modification. Microsoft C is \$395.

## ..... **New LCD Portables Use Backlit Display** .....

Zenith Data Systems is expected to introduce a lap-top portable computer with a backlit liquid-crystal display (LCD). The 16-pound Z-175 will include one or two 5¼-inch disk drives, 256K bytes of RAM, and an 80C88 processor for less than \$3000.

To counter the viewing angle and lighting problems caused by LCDs, Morrow Design also changed the 16-line by 80-character display on its Pivot computer, switching to backlit LCDs rather than relying on room light, despite the extra power consumed by the backlighting.

*(continued)*



## Proteon Adds 80-megabit-per-second Network

Proteon, which markets the ProNET token-passing star/ring hybrid local-area network, now offers a faster network. While ProNET used a 10-megabit-per-second data rate, ProNET-80 transfers information at 80 megabits per second. Proteon expects it to be used in applications using multiple minicomputers and mainframes or in connecting graphics workstations with large file sizes. The network will be available for Unibus and Multibus systems for about \$8000 per node.

## Intel Will Sell CalTech's Hypercube Multiprocessor Computer

Intel has licensed the hypercube computer design from the California Institute of Technology and will sell a computer based on that multiprocessor architecture. The computer consists of a multiprocessor cube and a cube manager. The cube includes 32, 64, or 128 computational nodes, each of which includes an 80286 processor, an 80287 math coprocessor, and 512K bytes of memory. Each node in the cube can communicate with five adjacent nodes and with the cube manager through 10-megabit-per-second communications channels. The cube manager is an Intel 286/310 microcomputer with 2 megabytes of RAM and a 40-megabyte hard-disk drive. Intel claims a performance range from 2.5 to 10 million floating-point operations per second with an efficiency of 80 to 99 percent. Prices range from \$150,000 to \$520,000.

## Torus Prepares to Launch LAN Software

Torus Systems Inc., Redwood City, CA, plans to introduce icon-based user-interface software for IBM PC network environments this month. The product will be based on Icon, the network software it says it has been selling since July in England for systems using 3Com's Ethernet network cards.

The program will include intranetwork electronic mail, telecommunications, file locking and sharing, and other network software features; users will also be able to run standard MS-DOS programs under the environment, either from local disks or from a file server.

## NANOBYTES

While announcing the Macintosh Office in late January (see February BYTE, page 120), **Apple** also announced the Macintosh XL, which is simply the Lisa renamed. . . . **Software Publishing Corporation** has added XMODEM file-transfer and remote computer access features to its \$140 pfs:Access program. . . . **Kensington Microware**, which advertised its Quick Cursor and Printer Buffer for Apple's Macintosh last year, has canceled development of those products. The company will continue to sell other "Maccessories". . . . **Mostek**, **Toshiba**, **Hitachi**, and **AT&T's Bell Labs** presented papers on CMOS 1-megabit RAM chips at the International Solid State Circuits Conference (ISSCC) in February; **IBM**, **NEC**, **Mitsubishi**, **Toshiba**, and **Fujitsu** discussed NMOS 1-megabit RAMs. Image-sensor chips were discussed by **Mitsubishi** and **Sharp**, and engineers from **AT&T's Bell Labs** discussed the development of a 32-bit floating-point digital-signal-processing chip. . . . **Mother Jones' Son's Software**, Reno, NV, is selling MJ, a set of background utility programs. In addition to redefining the PC's keys, MJ expands the IBM's keyboard buffer from 16 to 1000 keys, permits the cursor speed to be changed, and includes a password protection option. MJ costs \$30, or \$70, including source code. . . . **Digital Equipment Corporation** acknowledged in February that it had stopped manufacturing the Rainbow personal computer but said it will continue to ship from inventory and plans to announce a new version later this year. . . . **Syntech**, Canoga Park, CA, has announced a MIDI (musical instrument digital interface) adapter card for IBM, Apple, and Commodore computers. For the Apple or Commodore, the card is \$100; for the IBM PC, it's \$195. . . . **The Library Corporation**, Washington, DC, is selling a complete CD ROM system for the IBM PC, including a disc with records for a million English-language books, for \$2930. . . . **Corvus Systems Inc.**, San Jose, CA, has replaced its line of Omnidrive hard-disk drives with a single model that can be used with IBM PC; Apple II, III, and Macintosh; DEC Rainbow; and Zenith Z-100 computers. Corvus also dropped prices by about 30 percent. An 11-megabyte drive is now \$1995. . . . **Hammer Computer Systems Inc.**, Larkspur, CA, announced E-Z-DOS-IT, a \$200 program that allows up to eight MS-DOS programs to execute concurrently. . . . **Gold Hill Computers** has enhanced its Golden Common LISP interpreter and will also offer a GC LISP compiler in the summer. A large-memory-model version will also be available for the IBM PC AT.



The TI 855 is  
the only printer  
with letter quality,  
draft speed,  
graphics,  
plug-in font  
modules...  
all for under  
\$1000. (suggested retail price)



## Finally, the printer for all PC needs.

The TI 855 printer. The printer for all major PC's. See for yourself today. Call 1-800-527-3500 for the dealer nearest you.



  
**TEXAS  
INSTRUMENTS**  
Creating useful products  
and services for you.



# interact with a Genius



## **SUPER XT SYSTEM PLUS®**

Ultra-High resolution color card.  
Ultra-High (720x400) resolution color monitor.  
Gives excellent text resolution.  
10x16 character cell.

## **SUPER XT OFFICE SYSTEM PLUS®**

TTL monochrome monitor.  
Gives you easy-on-the-eyes viewing.

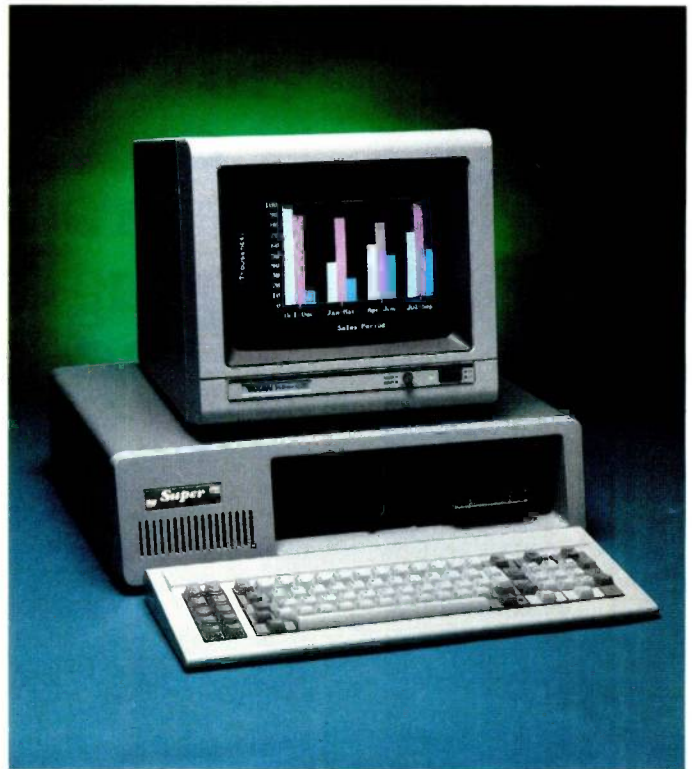

## **SUPER XT COLOR SYSTEM PLUS®**

High resolution color card and color monitor (640x200).  
16 colors.

## **SUPER XT STARTER SYSTEM PLUS®**

Composite monochrome monitor.  
Includes color graphics card.  
Gives you flexibility to run color and monochrome software.





# ... and feel the Power!

## SUPERPOWER 135

Hard Disk ready +12V at 4.5A max +5V at 15A max Same dimension and plug compatible W/IBM PC/XT. 3 Power outputs for 2 Floppies and a Hard Disk

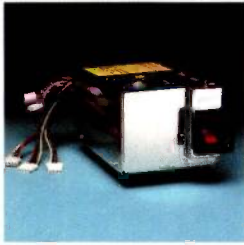

## SUPER CONTROLLER

Controls up to 4 Floppy drives Comes W/Cables for 2 Drives

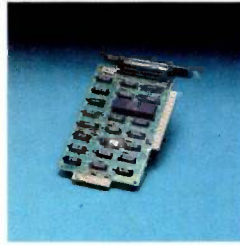

## SUPERBOX

Fully BUS compatible Adds 10 slots. 135 W Power supply for Hard Disk and Add-Ons External color same as IBM



## KEYBOARD

IBM PC, XT Plug compatible Corrected (left) "shift" key Color compatible W/IBM case



## SUPER DISK + I/O

Disk Controller Parallel & Serial ports Saves a slot in Motherboard

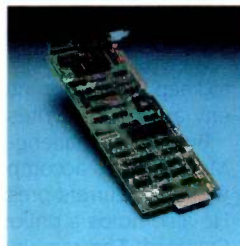

## HARD DISK CONTROLLER

Controls up to 2 hard disks Configurable for 5, 10, 20 and 33 Mb hard disks

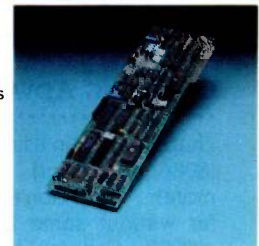

## SUPER MOTHERBOARD

Single layer double sided board Same dimensions as IBM motherboard Up to 256K Ram on-board memory 8 I/O slots

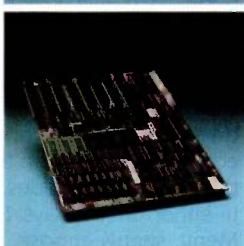

## SUPERSEVEN +

Disk Controller and cable. Clock/calendar Parallel, Serial and Game ports. RAM Disk emulator. Super Spooler software

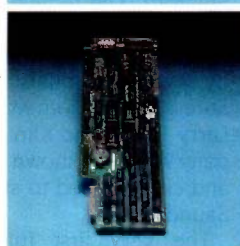

## HARD DISK ASSEMBLY

10 Mb formatted Fixed disk 5 Mb or 10 Mb formatted removable cartridge Unlimited storage Bootable from either fixed or removable hard disk



## MULTIFUNCTION CARD

Serial, Parallel, Game ports and Clock/Calendar W/memory expansion of added 384K RAM disk and print spooler software included

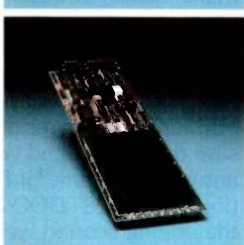

## SUPERBUFFER +

Does not use User's memory. Can be used as regular printer port W/O 64K buffer memory installed. Second parallel port included. Configurable as LPT1 or LPT2. Use Computer and print at the same time



## TAPE BACKUP

Backs up 10 Mb within 3 minutes Uses regular floppy controller



## TAXAN 555\* COLOR CARD

10x16 character cell to give the best text resolution in color (720x400) Graphic resolution (640x200) Operates Taxan 440\* monitor

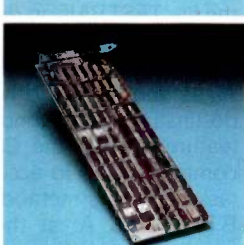

## SUPERCOLOR CARD

16 Colors on medium resolution 16K display memory Composite output W/RGB



## SUPERMONO CARD

720x348 resolution TTL output Printer port



## The Ultimate in PC/XT<sup>®</sup> compatibles and peripherals!

The Super XT Plus Series<sup>®</sup> computer offers the maximum alternatives in the PC/XT compatible market. Alternatives which exceed current PC/XT configurations. **Standard features on all Super XT Plus Series computers include:** Full Compatibility with IBM PC/XT<sup>®</sup> machines, 256K expandable to 640K bytes of parity checked memory, Eight (8) Slots, Two (2) Half-Height Floppy disk drives, 10 Mb Hard Disk,

Parallel, Serial, Game port and Clock/Calendar. **Options include:** 5 Mb Removable Hard Disk, 10 Mb Removable, Tape Backup System, Memory upgrade to 640K. With years of experience in manufacturing and distribution throughout the world—Super Computer gives you the buyer exceptional quality, reliability, and price on all Systems and Peripheral products. Super Computer warrants all Systems and

Products for a period of one year. The Super XT Plus Series computers and Peripherals expand to your requirements long after purchase. With features like this you are assured that the right choice is Super Computer. And the right choice is the Super XT Plus Series.

The Super XT Plus Series. Interact with the Genius of Super Computer.



**SUPER COMPUTER**  
Manufacturer/Distributor  
17813 South Main St. Suite 123, Gardena, CA 90248  
213/532-2133

© 1985 Super Computer, Inc.

**DEALER AND OEM INQUIRES INVITED**

**FAX 213/532-6342**  
**TELEX 3719484 SUPER**

Super XT System Plus, Color System Plus, Office System Plus, and Starter System Plus are registered trademarks of Super Computer, Inc.

IBM PC/XT is a registered trademark of International Business Machines, Corp.

Taxan is a registered trademark of Taxan Corp.

SEE US AT COMDEX-LOS ANGELES

APRIL 1985 • BYTE 13



## COVERING ADVANCED SYSTEMS

I have now been using a Fujitsu Micro 16s (8086 processor) for the past eight months, and I don't know how I got this far without some kind of micro. I am already planning for my next system, which will have either a 68020, a 16032, or a 32032 processor running UNIX.

Along with Jay Steinbrunn (Letters, August 1984, page 23), I too would like to see BYTE raise its sights and start to cover this future marketplace. Tell us what's happening out there so I can start putting money into my "purchase" account. I've seen a few inklings of this advanced micro technology at some of the shows, namely Saber Technology's use of the NS32032.

There are probably more of us out there that are interested in these advanced systems than you realize.

WILLIAM H. MESTLER  
Tarzana, CA

*Phil Lemmons replies:*

*We will keep an eye out for real 32-bit microcomputers at reasonable prices.*

## AN APPLE FOR BYTE

I want to compliment you on your special articles on the Apple computers (*The BYTE Guide to the Apple Personal Computers*, December 1984). The length of the articles showed that your company spent many hours choosing articles that would be enjoyed by the majority of readers. The articles were not only enjoyable, but they were also very informative. They showed an extreme amount of quality, which was the biggest impression I had after reading them. I commend your writers and company on a job well done.

KEVIN HOEKMAN  
Lakewood, CA

## WHERE CREDIT IS DUE

I have just read your December 1984 issue. I was impressed by "High-Speed Dial-up Modems" by Kim Maxwell (page 179). I found the article very informative and timely. Kim Maxwell's writing style is always very informative. He also manages

to keep the reader interested throughout any articles he writes.

But I must challenge the description of Mr. Maxwell's accomplishments. Mr. Maxwell is the current president of Racal-Vadic. He also holds a philosophy degree from Stanford. The remainder of the description is not correct.

Racal-Vadic was founded in April 1969 by seven individuals: Ted Saunders, Bob Stires, Jay Tutt, Tom McShane, Jim Barrick, Larry Taylor, and Kim Maxwell. The company was then known as Vadic. The ideas and circuits used to start Vadic were Ted Saunders's.

The very first full-duplex 1200-bps modem was invented and designed by John A. C. Bingham in 1972 during his employment at Vadic. Bingham must be given credit where credit is due. Mr. Bingham's talents and contributions need to be recognized.

This is not meant to take anything away from Kim Maxwell. It is just to set the record straight. Mr. Maxwell's contributions to the world of data communications are numerous, too numerous to list. He has peers in this group, but very few.

An engineer and investor at Vadic from November 1969 to November 1984, I saw most of the events during that period and was party to many. I also worked for both men and admire their talents and contributions to data communications.

DUANE MARCROFT  
San Carlos, CA

## WORDSTAR'S .BAK EXTENSION

I read Vincent Alfieri's "WordStar as a Programming Tool" (November 1984, page 505) with some enjoyment. I have long used WordStar for both program development and correspondence, and I agree with Dr. Alfieri's verdict that it is a program hard to beat in power and versatility. Even after several years of using WordStar, including writing patches and modifications to the program itself, it still manages to surprise me with its power.

I know that the problem that Dr. Alfieri has experienced with limited disk space is frustrating; I used to have the same problem myself. While my ultimate solu-

tion was to move to 8-inch disks, there are more immediately applicable fixes. The problem stems from the fact that WordStar saves the old version of an edited file, changing the file extension to .BAK. Having rescued program files from otherwise hopeless oblivion by the use of this feature, I am quite willing to put up with its rather extravagant use of disk space.

It is an almost undocumented feature of WordStar that allows you to specify a disk drive to receive all work files and the final edited file other than the drive on which the original file resides. This can be done in either of two ways. From the Opening Menu, simply choose "D" or "N," as appropriate, and when asked for the name of the file to edit, reply with the filename, but follow it with a space and a drive designator. For example, to edit the file TEST.DOC, which resides on drive B:, and save the final, edited version on drive A:, answer the "Name of file to edit?" question with B:TEST.DOC A:. When you end the editing session, you will be left with the file TEST.BAK on drive B:, and the file TEST.DOC on drive A:. For subsequent editing, it will be necessary to use drive A: as the source drive and B: as the destination. The second way to invoke this feature is from the CP/M (or MS-DOS) command line. To accomplish the same task using this method, simply type WS B:TEST.DOC A: at the A> operating-system prompt. You can change the mode (document or nondocument) to which WordStar will default using this method by using WINSTALL.COM.

If this still leaves you with insufficient room on the A: drive, WordStar can be run without the file WSMGS.OVR on the

(continued)

LETTERS POLICY: To be considered for publication, a letter must be typed double-spaced on one side of the paper and must include your name and address. Comments and ideas should be expressed as clearly and concisely as possible. Listings and tables may be printed along with a letter if they are short and legible.

Because BYTE receives hundreds of letters each month, not all of them can be published. Letters will not be returned to authors. Generally, it takes four months from the time BYTE receives a letter until it is published.



# *Hard Drives*

## *You Can Forget About.*

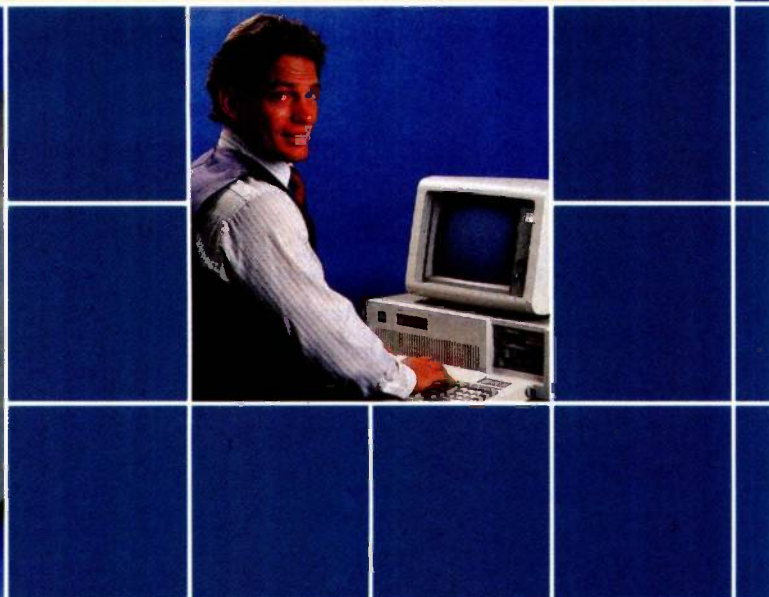

The nicest thing about Maynard's hard drives is their humility. They never draw attention to themselves. They simply do what you tell them to do, so you can keep your mind on your work, not your hardware. Unsurpassed performance. Versatile design. Superb reliability. We give you an awful lot to forget about.



*Internal, external, or portable  
hard drives from 10 to 30MB.*



**Maynard Electronics**

430 E. SEMORAN BLVD., CASSELBERRY, FL 32707

305/331-6402

Inquiry 253



FINALLY! MAIL ORDER SERVICE YOU CAN DEPEND ON!

# EXPRESS

BUSINESS SOFTWARE

PROFESSIONAL SUPPORT PLUS RELIABLE PERSONALIZED SERVICE  
AND WE'LL STILL BEAT MOST PRICES IN THIS MAGAZINE!

<b>WORDSTAR PROPAC</b>	<b>SYMPHONY</b>	<b>SIDEKICK (C.P.)</b>	<b>SUPERCALC 3</b>	<b>TAX WIZARD</b>	<b>LOTUS 1-2-3</b>
<b>\$243</b>	<b>\$409</b>	<b>\$35</b>	<b>\$193</b>	<b>\$59</b>	<b>\$295</b>

<b>AID</b> Typequick <b>ALPHA SOFTWARE</b> Data Base Manager 2 <b>ANDERSON-BELL</b> Abstat <b>ASHTON-TATE</b> D Base II D Base III Framework Friday <b>ATI</b> Training Word Star Training dBase III <b>BORLAND INTERNATIONAL</b> Toolbox Turbo Pascal <b>COEX</b> Advanced Lotus 1-2-3 <b>CHANG LABS</b> Rags to Riches Ledger <b>CONDOR</b> Condor 3 <b>CONTINENTAL SOFTWARE</b> Home Accountant Plus <b>DIGITAL MARKETING</b> Writers Pak Milestone (PC) Datebook II Proofreader <b>ENERTRONICS</b> Energraphics Plotter Option <b>FOX &amp; GELLER</b> DGraph dUtil Quickcode II or III <b>FUNK</b> Sideways <b>HARVARD SOFTWARE</b> Harvard Project Mgr <b>HERITAGE</b> Smart Key	85 295 395 495 695 695 295 75 75 54 54 70 99 650 150 250 250 150 50 350 100 295 99 295 60 395 90	85 169 267 265 363 169 45 45 35 35 45 79 239 89 165 165 98 38 259 55 155 58 145 40 230 65	<b>IUS</b> Easy System II General Ledger Accounts Payable <b>KOALA</b> Touch Tablet (PC) MacVision <b>LEXISOFT</b> Spellbinder <b>LIFETREE</b> Volkswriter Deluxe <b>LIVING VIDEO TEXT INC.</b> Think Tank (IBM) Think Tank (Mac) <b>MDBS</b> Knowledgeman K Paint K Graph <b>MECA</b> Managing Your Money <b>MICROGRAFX</b> P C Draw <b>MICROPRO</b> WordStar SpellStar CorrectStar MailMerge InfoStar WordStar 2000 WordStar 2000 Plus <b>MICRORIM</b> R Base 4000 Extended Report Writer Clout <b>MICROSOFT</b> Multiplan Word/Mouse Chart (MAC) Project <b>MICROSTUFF</b> Crosstalk	395 595 595 150 400 495 295 195 150 500 100 225 199 395 350 99 145 99 495 CALL CALL 495 150 250 195 475 125 250 195 98	184 295 295 95 250 239 158 109 99 275 65 145 119 290 179 55 55 248 CALL CALL 259 109 135 139 299 99 179 98	<b>MONOGRAM</b> Dollars and Sense (IBM) Dollars and Sense (Mac) <b>MULTIMATE INTERNATIONAL</b> Multimate <b>OASIS</b> Word Plus Punctuation and Style <b>PEACHTREE</b> Peachtext 5000 Calendar Management Decision Manager Business Graphics System Peachpak 4 <b>PETER NORTON</b> Norton Utilities (Vers. 3.0) <b>PRENTICE-HALL</b> Execuision <b>PRO TEM SOFTWARE</b> Notebook II Footnote <b>ROSESOFT</b> Prokey <b>SAMNA</b> All Products <b>SORCIM</b> SuperCalc 2 Super Project <b>SOFTWARE PRODUCTS INT'L</b> Open Access <b>SOFTWARE PUBLISHING</b> PFS File or Write SSI Word Perfect <b>TELOS</b> Filevision (Mac) <b>TYLOG</b> dBase Window <b>WARNER SOFTWARE INC.</b> The Desk Organizer <b>WOOLF SYSTEMS</b> Move It	179 149 495 253 150 150 425 195 625 295 395 100 395 299 189 99 130 79 CALL 295 219 695 349 140 85 495 249 195 249 155 195 129 150 85
--	--	--	---	---	---	---	---

Free UPS shipping on orders over \$1,000.00  
CALL FOR PRODUCTS YOU DON'T SEE HERE!  
CALL FOR OUR FREE CATALOG

TO ORDER CALL TOLL-FREE:  
(800) 235-3020 (USA)  
(800) 235-3021 (CA)  
(415) 382-9085



448 IGNACIO BLVD., STE. 332  
NOVATO, CA 94947

**TERMS:**

- Call for shipping charges and support policies
- Full guarantee against manufacturers defects
- Allow 3 weeks for checks to clear
- Prices may change
- Call for availability
- No cash refunds!
- Due to our low prices, all sales final.

- SAME DAY SHIPMENT ON MOST ORDERS
- Prompt UPS service
- Authorized purchase orders accepted
- Dealer, institutional and quantity discounts available
- No surcharge for credit card purchases
- VISA & Mastercard accepted
- COD

LETTERS

system disk. All messages, including menus, will appear as "@@@@" in the upper left-hand corner of the screen, but if you have sufficient knowledge of WordStar's command structure, that shouldn't be more than an inconvenience.

As I mentioned, this feature is not well documented and, I must admit, it is of limited usefulness, except in certain situations when it makes the impossible possible.

NICK BURKITT  
Long Beach, CA

As someone who uses WordStar professionally on nearly a daily basis, both at work (as a technical writer) and at home (as a freelance writer), I was flabbergasted at several pieces of misinformation and bad advice offered by Dr. Vincent Alfieri in "WordStar as a Programming Tool."

Late in the article, Dr. Alfieri describes WordStar's "strange habit of keeping a backup file every time you edit an existing file. This means, in effect, that you must maintain a great deal of disk space for the necessary backup files."

So backup files (denoted by the .BAK extension) are bad, since they eat up disk space. Or are they?

Dr. Alfieri's attitude toward the WordStar backup procedure is perplexing, especially since one can justify WordStar's backup procedure by simply providing a better solution to a problem "solved" by Dr. Alfieri early on in the article. There, he recommends that, if you have recently saved and accidentally delete an important line of code, you can use the ^KQ (quit without saving file) command. He is silent on what to do if you haven't, which is frequently the case if you are on a roll.

However, thanks to WordStar's backup procedure, the situation isn't bad at all, even if you've got an hour's work behind you in the current file with no saves at all. All you really have to do is use ^KD (quit and save file). Following this, you will find that WordStar has created a file with a .BAK extension on the disk.

You can then edit this file (after changing or removing the .BAK extension). This allows you to find the missing text and block write it to disk. You can then reedit the original file, find the location of the missing text, and read it off the disk. This procedure is quick, easy, and involves no loss of text.

But even WordStar with its powerful backup feature cannot defeat those who work to defeat it, as Dr. Alfieri does when he suggests using files distinguished solely

(continued)



# ProModem 1200... **HOT-LINE**

## Our ProModem 1200 Makes Smart Modems Look Dumb



ProModem 1200 (RS-232)



ProModem 1200M (Macintosh)

### Send Or Receive 50 Pages Of Text Without Tying Up Your Computer

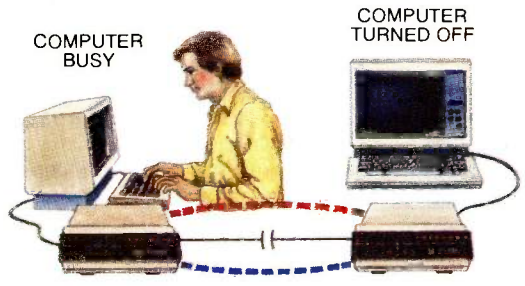

No wonder Smart Modems, Cats, and Maxwells cringe when compared to our \$495 ProModem 1200, an expandable 1200/300 baud modem for use with all personal computers. It costs less, but is smarter than the rest.

And when you add our \$99 Communications Buffer and Alphanumeric Display options, ProModem 1200 becomes a veritable genius!

Imagine, you unplug your computer, take it home for the weekend, and while you're gone, ProModem 1200 answers the phone, collects messages up to 50 pages long, sends out electronic mail, and displays all events with the exact time of each. Thanks to ProModem 1200, expensive, hard-to-use communications software isn't needed. The communications is in the modem, and electronic mail becomes a background function, where it belongs.

### Simple To Install And Use

Our Communications Buffer is a 4 by 6 card that plugs into the ProModem 1200 motherboard. It comes with 2K of CMOS battery backed-up memory, expandable to 64K. Part of the memory is used as a dialing directory with the balance reserved for storage. For \$99 more, a front panel Alphanumeric Display can be added to show time, date, and 24 status and help messages. These two powerful options can be included at time of purchase, or can be added later.

### Hayes Compatible

ProModem 1200 is Hayes compatible but that's where the resemblance ends. Our standard \$495 modem includes a real-time clock/calendar. Hayes charges hundreds more for a Smart Modem with a time-base. Nor do they have electronic mail capability at any price.



ProModem 1200 contains a battery backed-up real-time clock/calendar, a large dialing directory and can send or receive messages up to 50 pages long without tying up the computer.

Send for complete details and the name of the Prometheus dealer nearest you.



*The Hot Line*

**PROMETHEUS PRODUCTS INCORPORATED**  
4545 Cushing Pkwy. • Fremont CA 94538

Call Now For Complete Info...  
**415/490-2370**



**New Release  
4.1**



We've continually improved Microstat since it was introduced in 1978, and the latest release includes many new features you've wanted.

Interactive and Batch Processing  
Expanded Data Management Subsystem with New Data Transforms  
Reading data files created by other programs  
3 types of Analysis of Variance  
Time Series  
Crosstabs and Chi-Square  
Factorials, Permutations, and Combinations  
Hypothesis Tests

Data sets that can exceed memory  
Multiple Regression (including Stepwise)  
Scatterplots (including best fit regression)  
Correlation Analysis  
12 Nonparametric tests  
8 Probability Distributions  
Descriptive Statistics  
Easy Installation

Microstat's algorithms have been designed to prevent numeric overflow errors and yield unsurpassed accuracy. Microstat's price is \$375.00 including the user's manual and is available for the Z80, 8086, 8088 CPU's and CP/M80, CP/M86, MS-DOS, and PC-DOS. To order, call or write.



6413 N. College Ave. • Indianapolis, IN 46220  
(317) 255-6476



Trademarks: Microstat (Ecosoft), CP/M (Digital Research), MS-DOS (Microsoft), PC-DOS (IBM), Z80 (Zilog), 8086, 8088 (Intel).

**LETTERS**

in terms of extensions (he suggests "P.1," "P.2," "P.3," etc.). Yes, in this case WordStar will keep only one backup for each of those files. That's great, if you're sure you'll never need a backup of any but the most recently edited file. I, for one, am not so confident.

Obviously, I think there are good reasons for backup files. Dr. Alfieri reminds us to keep *separate* backup files, but I know from nearly 10 years of working with computers and six years of working with WordStar that most people forget to back up their work, especially if they haven't lost any work lately. We WordStar users tend to be less sorry than most.

Finally, I am puzzled by Dr. Alfieri's contention that "You can actually get *more* pages on a disk with many small files than with one large file." This isn't entirely true, of course, except during an actual editing session.

Every file has overhead, and many systems allocate disk space in 2K-byte increments, including a minimum 2K-byte file size. Thus, it's easy to eat up disk space by having numerous files with somewhere between a few bytes and 2K bytes of unused bytes per file. Let's say that it's 1K byte on the average.

Then, if you take our example 180K-byte disk again and put 30 files of nominally 4K bytes each on it, it adds up to 120K bytes "used" and 60K bytes "free." The truth, however, is that about 30K bytes of disk space is eaten up in overhead. That's about 15 pages of text! If your system allocates in 1K-byte increments, that's still 15K bytes!

When you're editing a backed-up file, WordStar can require about three times the capacity of the file on the disk (one old backup, one working backup, and the file being edited). This means that on a disk with 180K bytes (formatted), you might want to avoid editing a file of 55K bytes or greater, especially if you expect to be expanding it by much.

The best solution is probably to work on one disk and keep a separate disk for file saves. If you save to this disk after each edit, then you can delete the .BAK files as you go, meaning that on a 180K-byte disk, you can safely edit a much larger file of 80K bytes or more.

THOMAS H. HUNSCHER  
Tigard, OR

**NEWS FOR SORCERER OWNERS**

May I suggest that BYTE try to mention the many orphans that have arisen in the

(continued)

**TOTAL CONTROL:**

**FORTH: FOR Z-80®, 8086, 68000, and IBM® PC**

Complies with the New 83-Standard

**GRAPHICS • GAMES • COMMUNICATIONS • ROBOTICS  
DATA ACQUISITION • PROCESS CONTROL**

● **FORTH** programs are instantly portable across the four most popular microprocessors.

● **FORTH** is interactive and conversational, but 20 times faster than BASIC.

● **FORTH** programs are highly structured, modular, easy to maintain.

● **FORTH** affords direct control over all interrupts, memory locations, and i/o ports.

● **FORTH** allows full access to DOS files and functions.

● **FORTH** application programs can be compiled into turnkey COM files and distributed with no license fee.

● **FORTH** Cross Compilers are available for ROM'ed or disk based applications on most microprocessors.

Trademarks: IBM International Business Machines Corp., CP/M, Digital Research Inc., PC/Forth+ and PC/GEN, Laboratory Microsystems, Inc.

**FORTH Application Development Systems** include interpreter/compiler with virtual memory management and multi-tasking, assembler, full screen editor, decompiler, utilities and 200 page manual. Standard random access files used for screen storage, extensions provided for access to all operating system functions.

**Z-80 FORTH** for CP/M\* 2.2 or MP/M II, \$100.00;

**8080 FORTH** for CP/M 2.2 or MP/M II, \$100.00;

**8086 FORTH** for CP/M-86 or MS-DOS, \$100.00;

**PC/FORTH** for PC-DOS, CP/M-86, or CCPM, \$100.00; **68000 FORTH** for CP/M-68K, \$250.00

**FORTH+ Systems** are 32 bit implementations that allow creation of programs as large as 1 megabyte. The entire memory address space of the 68000 or 8086/88 is supported directly.

**PC FORTH+** \$250.00

**8086 FORTH+** for CP/M-86 or MS-DOS \$250.00

**68000 FORTH+** for CP/M-68K \$400.00

**Extension Packages** available include software floating point, cross compilers, INTEL 8087 support, AMD 9511 support, advanced color graphics, custom character sets, symbolic debugger, telecommunications, cross reference utility, B-tree file manager. Write for brochure.



**Laboratory Microsystems Incorporated**  
Post Office Box 10430, Marina del Rey, CA 90295  
Phone credit card orders to (213) 306-7412





# AST makes modems Short 'n Sweet

## Introducing Reach!™

Our new intelligent 1200 baud modem fits where the old standard can't—into a single short slot on the IBM® PC-XT or Portable. Or any available expansion slot on the PC, AT and PC-compatibles. And it's packed with advanced features.

The Reach! half-card design is about a half a pound lighter too.



So it makes a much nicer traveling companion than old fashioned external modems or heavier, long slot internal modems.

Tapping into services such as news from Dow Jones® information from THE SOURCE™ and electronic mail delivery from MCI Mail™ and performing PC-to-PC data transfer has never been more convenient.

AST's reputation is built on quality products, quality support and quality service. Our com-

plete documentation makes Reach! exceptionally easy to install and use, but if it's not enough we're always here to help.

Reach! from AST—the short and sweet solution to your telecomputing needs. Call our Customer Information Center (714) 863-1333 Ext. 5249 for more information and dealer locations. Or write, AST Research, Inc., 2121 Alton Ave., Irvine, CA 92714 TWX: 753699AST UR.



**AST** RESEARCH INC.

## Sweet Performance

### Crosstalk XVI® Software:

*The industry's best async communications software and its excellent documentation is included at no extra charge.*

**High Noise Immunity And Low Bit Error Rate:** *Insures data integrity even at 1200 bps over noisy, low-grade phone connections, eliminating the inconvenience and cost of retransmission because of noise-induced data errors.*

**On-Board Speaker:** *Lets you hear all the signals, just as if you were dialing the phone yourself, a convenient indication of proper operation.*

**Remote Digital Loopback:** *Used with a remote site, these diagnostics provide "real world" data transmission testing over the phone line.*

**Hayes® Compatibility:** *Opens up a world of popular, immediately available software to you.*

### Telecommunications

**Flexibility:** *Enjoy a choice of 110, 300 or 1200 baud speeds, Bell 103, 113 and 212A compatibility, automatic-dial, answer and speed selection, and both half- and full-duplex communications.*

### Call Progress Monitoring:

*Provides complete knowledge of communications progress, monitors dial tone (important in offices where you must dial "9" first), ringing, busy signal and automatically disconnects no answer calls.*

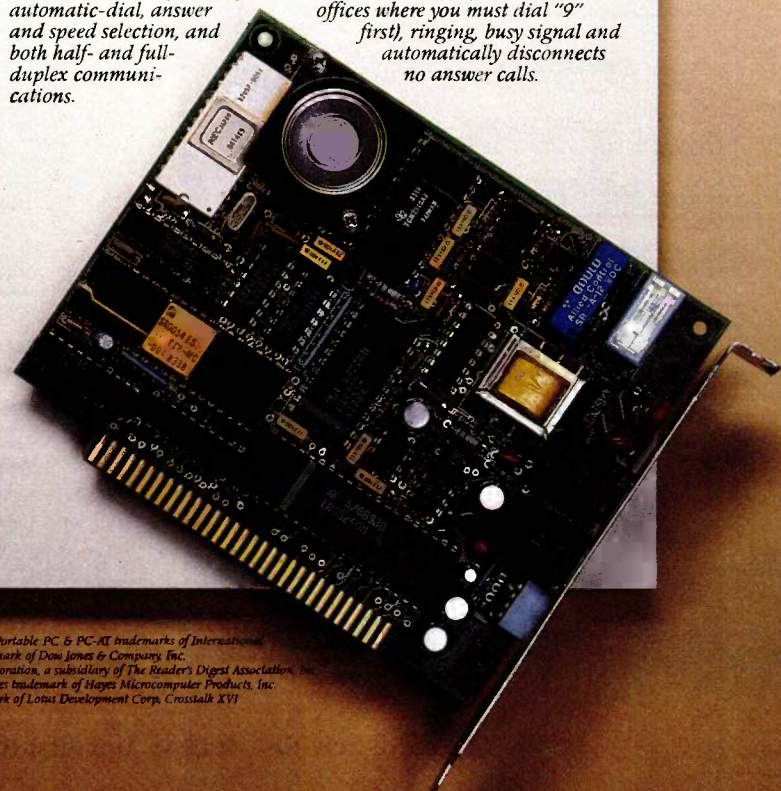

Reach! trademark of AST Research, Inc. IBM, PC, PC-XT, Portable PC & PC-AT trademarks of International Business Machines Corp. Dow Jones News/Retrieval trademark of Dow Jones & Company, Inc. THE SOURCE service mark of Source Telecomputing Corporation, a subsidiary of The Reader's Digest Association. MCI Mail trademark of MCI Communications Corp. Hayes trademark of Hayes Microcomputer Products, Inc. Prusnetwork trademark of Ashton-Tate. Symphony trademark of Lotus Development Corp. Crosstalk XVI trademark of Microsoft, Inc.



# Quick doesn't have to

Before Microsoft® Word you had to choose between quick and clean. Producing professional looking documents meant going through draft after draft after draft after draft.

The new Microsoft Word is different. You don't have to practice to make perfect. You can use the full power of the IBM® PC to eliminate the drafts. And give your ideas sudden impact.



## Quick quality.

With Word, what you see on the screen is what you'll see on the page. You can preview and design documents. And instantly see the effect of your changes. (No more playing blindman's bluff between the screen and the printer.) Now you can breathe vitality into blocks of lifeless text.

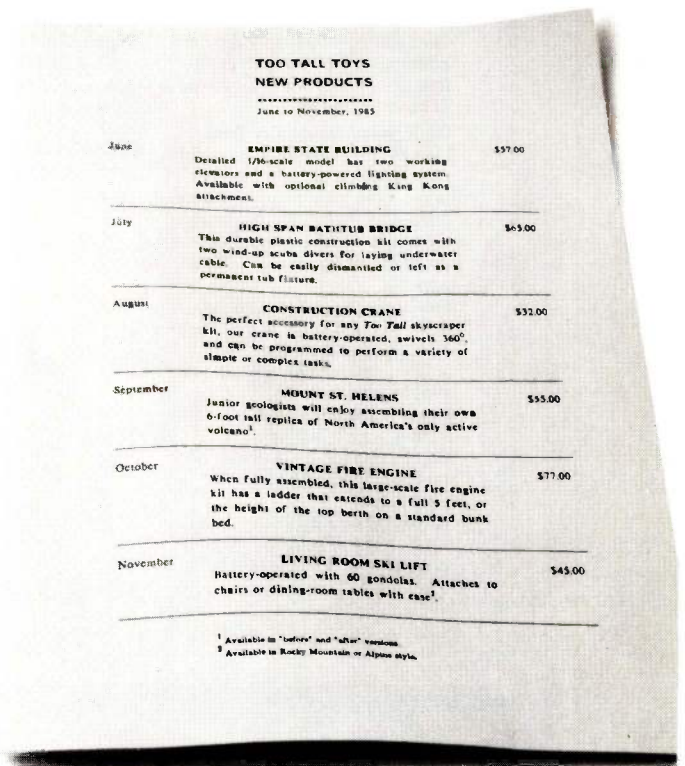
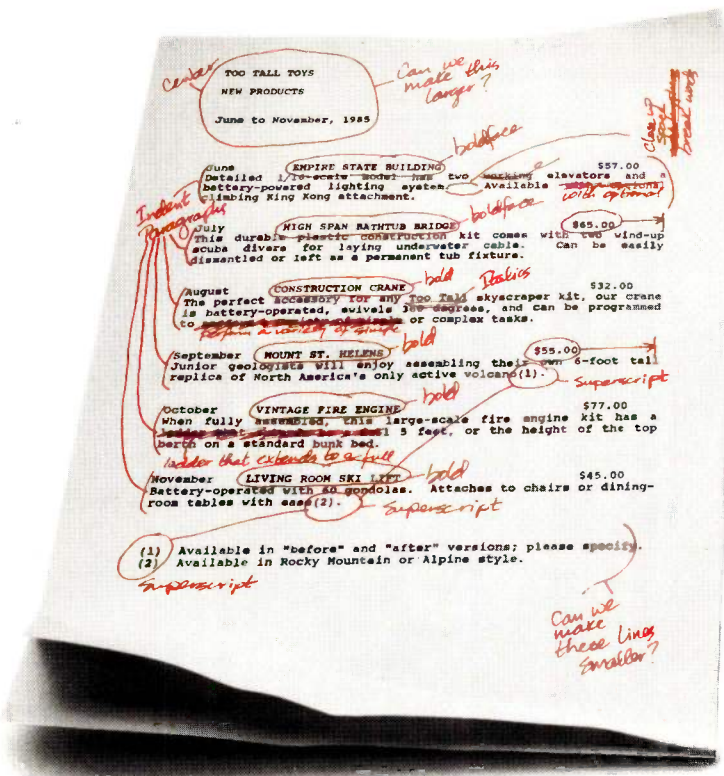

Their first draft vs. our first draft.



# be dirty.

Highlight pithy phrases, flag important words, drive home conclusions. With **boldface**, underline and *italics*, <sup>superscript</sup> and <sub>subscript</sub>. (No more hieroglyphic codes.)

Microsoft Word gets unmatched professional quality from dot matrix, daisy wheel and ink jet printers. And on the new laser printers, it produces stunning results.

It lets you execute commands and edit text faster, with simple keystrokes or the optional Microsoft Mouse. And, **MICROSOFT** The High Performance Software<sup>®</sup> Word has windows so you can have multiple documents on the screen, and you can easily cut and paste between them.

Word also includes a computer-based training disk that gets you up to speed quickly. Plus, a new comprehensive manual.

## 100% money-back guarantee.

You don't have to take our word about Word. Buy the new Microsoft Word from a participating dealer and if you're not satisfied for any reason, return it to the dealer within 30 days and he'll give you your money back.\*

How do we get higher performance out of the PC? Simple, our MS-DOS<sup>®</sup> operating system tells the IBM PC how to think. And our BASIC is the language spoken by nine out of ten microcomputers worldwide.

So, if you want to clean up your act, act quick. Call (800) 426-9400. In Washington State, Alaska, Hawaii and Canada, call (206) 828-8088. And ask for the name of your nearest Microsoft dealer.

Microsoft and MS-DOS are registered trademarks and The High Performance Software is a trademark of Microsoft Corporation. IBM is a registered trademark of International Business Machines.

\*Offer good in the United States on IBM PC versions of Microsoft Word purchased on or before August 31, 1985.

A hand is shown from the bottom right, holding a large, bold, black logo that reads 'MSOFT'. The logo is partially obscured by the hand and appears to be a stylized representation of the Microsoft logo.



computer field. There are many micros that have no support now, and users who still have them are looking for help.

Ah, nostalgia! Remember Superbrain, TRS Model 1, IMSAI, Videobrain, and Exidy Sorcerer? Some people still have them but think they are frozen in time.

For some machines, that is not so.

The Exidy Sorcerer was still being made in 1984, under license in Holland. And there are still many fan magazines with software and hardware notes being published.

For the Exidy Sorcerer here are some of the magazines being published. (Write for subscription rates and possibility of back issues.)

**European Sorcerer Club**

Back issues only  
Died with issue 43 in June 1984  
Index in issue 26

Colin Morle  
32 Watchyard Lane  
Formby  
Near Liverpool L37 3JU  
England

**Sorcerer Group International**

c/o Don Gottwald  
POB 33  
Madison Heights, MI 48071  
U.S.A.

Back issues from Gottwald at:  
19967 Rosin Dr.  
Mt. Clemens, MI 48044  
U.S.A. (about \$18 per volume for vols. 2 to 5)

now **Sorcerer Group International**  
(8 times a year)

Tommy Stokes (or Ed King)  
Route 1, Box 121  
Everton, AR 72633  
U.S.A.

**Sorcerer Computers Users of Australia**

(12 a year/Airmail)  
Box 2402  
Melbourne, Victoria 3001  
Australia

**Southern California Sorcerer Users Group**

(4 to 6 a year casually)  
c/o Cary E. Stewart  
529 South Beachwood Dr.  
Burbank, CA 91506  
U.S.A.

**ISIS** (12 a year)  
c/o Maurice Dow  
84 Camberley Crescent  
Brampton, Ontario L6V 3L4  
Canada

**Sorcerer User Group of South Australia** (12 a year)

c/o Don Ide  
14 Scott Rd.  
Newton, South Australia 5074  
Australia (index in issue 51)

**Exidy Sorcerer Gebruikers Group**

(6 a year)  
Published in Dutch with full English cover-to-cover translation a month later  
Index in issue 15

**Redactie ESGG**

P/a Postbus 510  
NL-1000 Amsterdam  
The Netherlands

**Sorcerer User Group Schweiz**

Monthly/in German  
  
CH 3038 Kirchlindach  
Switzerland (index in issue 50)

**Sorcerer Computer Users of New Zealand**

Monthly, some Sorcerer material  
  
c/o Selwyn Arrow  
POB 6210  
Auckland, New Zealand

I won't give prices since they will change and many of the above don't know rates to the U.S. since no one has asked before. Here are some software sources for the Sorcerer that you might want to keep on file:

**Arrington (Ensign) Software**

7337 Northview  
Boise, ID 87304  
U.S.A.

**Howard Arrington**

Suite E, 2312 North Cole Rd.  
Boise, ID 87304  
U.S.A. (This is an old address.)

**COMTRO Software Development**

Rec. Bonsel Str. 10  
NL-6433 EP Hoensbroek  
The Netherlands

**Roger Hagan**

1146 Fairview Ave. North  
Seattle, WA 98109

**System Software**

1 Kent St.  
Bicton, Western Australia 6157  
Australia

**Nigel Yeo**

24 Bodmin Ave.  
Macclesfield, Cheshire  
England

**Calcom BV**

Nijverheidsstraat 22  
NL-2802 AL Gouda  
The Netherlands

**Softdeal**

Postbus 85  
NL-1135 ZJ Edam  
The Netherlands

**Computer Collectief**

Amstel 312 (t.o. Carre)  
NL-1017 AP Amsterdam  
The Netherlands

And some hardware help, firmware, and repair services:

**B. J. (Bob) Freeman**

414 Olive Way  
Seattle, WA 99202  
or  
POB 1258  
Seattle, WA 98111-1258  
U.S.A.

**Ion Weather**

Morristown Municipal Airport  
Morristown, NJ 07960  
U.S.A.

**Tercentennial Technical**

70 Tercentennial Dr.  
Billerica, MA 01821  
U.S.A.

**South Valley Electronics Inc.**

Suite E, 2110 Walsh Ave.  
Santa Clara, CA 95050  
U.S.A.

**Mentzer Electronics**

590 South Hill Boulevard  
Daly City, CA 94014  
U.S.A.



**The Brothers Van Montfort**

(Gebroeders van Montfort)  
Smedestraat 13  
NL-6411 CR Heerlen  
The Netherlands

DANIEL SAY  
Vancouver, BC, Canada

**APPLE II BLUES**

I happened on Mr. Dennis Doms's letter ("A Call for Better Apple Support," September 1984, page 14) and but for near-identical circumstances, I would have dismissed it as one of those individual quirks in product support. I fully endorse Mr. Doms's comments. His perceptiveness of the ProDOS documentation problem is particularly commendable when one considers the fact that he is experienced in DOS 3.3!

In early March of this year our information-processing group decided that a small "user-friendly" micro might provide quick turnaround for some of our project record-keeping applications. Although the senior program manager was a Kaypro owner, he carefully avoided imposing his own preference on the organization. An Apple II+ owner made a seemingly sound recommendation that we get an Apple IIe with duodisk and a small dot-matrix printer.

Two days later, the Apple IIe arrived with its display, an Epson printer, and the duodisk. VisiCalc and two PFS packages also were provided to get things started. A seeming ton of books accompanied the units. A quick pilot run with VisiCalc and PFS was made, and a short training session was held for floor engineers and project managers.

People experienced losses of whole files, mutilation of data, and I/O errors using PFS. The possibility of human error was explored, and new data backup procedures were instituted. Repair of the duodisk decreased the variety of I/O errors but did not eliminate them. Substitution of the duodisk with two stand-alone drives did not help. The Apple technician blamed the problem on PFS. The salesman who had originally sold us the Apple and the software then sold us Appleworks. The users read Appleworks documentation, more training sessions were held, new files were established, data was reentered. Within a day there were more I/O errors and losses of data reported. The Apple dealer then replaced the main logic board and again worked on

(continued)

# More terminals without more computer

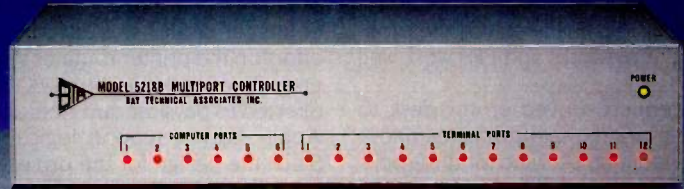

The advantages are clear. A BayTech port contender adds more users to your computer and does it at a price that's far less than expensive hardware or software modifications. A Model 5218B, for example, doubles your users by allowing 12 terminals to contend for 6 ports. Simple to set up and use, with easy-to-understand messages, the port contenders feature protocol conversion; user queue; disconnect by operator, computer or time-out; hardware or X-ON/X-OFF handshaking; and more. **(800) 523-2702**  
Seven models, \$629 to \$1,750.



**BayTech®**

DATA COMMUNICATIONS PRODUCTS

Bay Technical Associates, Hwy. 603, P.O. Box 387, Bay Saint Louis, Mississippi 39520  
(601) 467-8231 Telex: 9103331618 (BAY TECH)

# Share printers easily and automatically



Instead of adding more printers, get maximum use of the printers you have by adding a BayTech multiport controller. A versatile D-series multiport allows several RS-232C devices to share printers or plotters. No cable-switching, knobs to turn, or software to add. These printer sharers work automatically; just hook them up and they're ready to use. Features include custom power-up default configuration, protocol conversion, buffer, and your choice of hardware or X-ON/X-OFF handshaking. **(800) 523-2702**  
Seven models, \$319 to \$629.



**BayTech®**

DATA COMMUNICATIONS PRODUCTS

Bay Technical Associates, Hwy. 603, P.O. Box 387, Bay Saint Louis, Mississippi 39520  
(601) 467-8231 Telex: 9103331618 (BAY TECH)



the duodisk. This finally solved the problem (both Appleworks and PFS work well now).

A task request arrived on my desk to write some printer set-up utilities and a project accounting package for the Apple. Coming from a CP/M-86, TRSDOS, and IBM-VS background, I didn't instantly see the relationship between the Apple DOS and BASIC. The undocumented "loading

of Integer BASIC" was disturbing. My first effort on the printer routines worked well enough (after I found that I/O had to be directed to physical card slots and that the Apple did not support logical devices!). Since the design for the project accounting task involved multiple files and several large arrays, I broke out the books.

As in Dennis Doms's case, we had received a ProDOS users manual and an

Apple IIe owners manual. These had no substantive information that documented the machine or Apple's software. The paper quality was nice; the indexes and tables of contents had errors. The ProDOS manual talked about differences from DOS 3.3 and seemed aimed at people familiar with Apple DOS. The ton of books also included books for the 80-column card, the Apricot printer card, a duodisk manual, a pamphlet for the display, and several excellent manuals for VisiCalc, PFS, and the Epson printer.

I called our dealer and was told that we deserved a ProDOS *Programmer's Manual* since it had been out of stock when we bought the machine. He did not have one but would special-order one for us. I described my needs for documentation and was told I would need the Applesoft and DOS 3.3 manuals and that these were extra-cost items. I was told to ignore all references to Integer BASIC since it was an "archaic tongue" and no documentation was in print for it. (Undocumented modules of an operating system bother me!) The pricing was confused, but a total of \$70 plus tax finally went on our purchase order. We soon received a bill. Two trips to the dealer and multiple phone calls over a six-week period failed to produce the manuals. There was talk of them being in a warehouse, then being back-ordered from Apple, then being out of print. Finally, with a Friday promise that they would be mailed on Monday, Accounting paid the bill. Two weeks later the dealer produced an explanation that the required manuals were unavailable from Apple and there was no projected delivery date.

Two months after the first phone call about documentation, our "free" ProDOS *Programmer's Manual* arrived. It was much as Mr. Doms describes—dependent on the DOS 3.3 and Applesoft documentation. The senior program manager visited the Apple dealer and with some hostility offered an invitation to small-claims court. The salesman then gave us his personal copies of the DOS 3.3 and Applesoft manuals. We then considered that the purchase order had been filled!

Our company's purchasing agent will ensure that no more business is directed to the Apple dealer who sold us the IIe. Apple's viability in the microcomputer business is doubted by every engineer, project manager, and technician who has been associated with our IIe. We now have three more Kaypro owners. At the office I'm pleased by the Displaywriter with its

(continued)

## If lightning still scares you, you're using the wrong file manager.

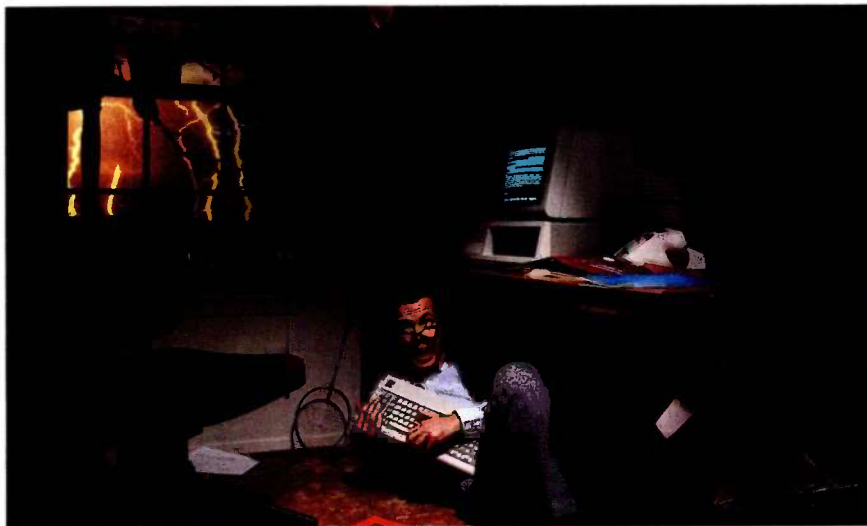

### Be sure. Btrieve™.

Lightning may strike. But it doesn't have to destroy your database.

Btrieve™ file management offers automatic file recovery after a system crash. So accidents and power failures don't turn into database disasters. Your Btrieve-based applications will come up when the lights come back on.

**Fast.** Btrieve is lightning fast, too. It's written in Assembly language especially for the IBM PC™. And based on the b-tree file indexing system, with automatic balancing and electrifying access speed.

**The standard for networking.** Ptrieve/N (network version) sets the standard for the industry's most popular LANs, including IBM's PC Network.

**Fully-relational data management.** SoftCraft's entire family of products

gives you a complete, fully relational database management system. Rtrieve™ adds report writing capabilities. Xtrieve™ speeds users through database queries with interactive menus.

**For professional programmers.** Btrieve is the fast, reliable answer for all your application development. In any development language—BASIC, Pascal, Cobol, C, Fortran, and APL. With Btrieve, you can develop better applications faster. And know they'll be safe if lightning strikes.

**SC** SoftCraft Inc.

P.O. Box 9802 #917 Austin, Texas 78766  
(512) 346-8380 Telex 358 200

Suggested retail prices: Btrieve, \$245; Btrieve/N, \$595; Xtrieve, \$195; Xtrieve/N, \$395; Rtrieve, \$85; Rtrieve/N, \$175. Requires PC-DOS or MS™-DOS 1.X, 2.X, or 3.X. Btrieve, Xtrieve, and Rtrieve; IBM; and MS are trademarks of SoftCraft Inc.; International Business Machines; and Microsoft Inc.



# If you don't have a Hercules Graphics Card, you could end up looking like this:

"I know, because one day it happened to me . . .

"I was running some routine tests on a non-Hercules monochrome graphics card when I was struck by a severe case of *low resolutionitis*. I'm the president of Hercules and that's me exhibiting the symptoms of the disease in its advanced stages. Not a pretty sight, is it?

"What causes *low resolutionitis*? Experts point to ordinary monochrome graphics cards with coarse, hard-to-read graphics. A bad case of eyestrain may develop if action is not taken immediately.

"Fortunately for me, a Hercules Graphics Card was nearby. A quick change brought soothing 720 x 348 graphics. That's twice the resolution of ordinary 640 x 200 graphics cards.

"Which means better graphics for Lotus™ 1-2-3™, Symphony™, Framework™, pfs:Graph™, Microsoft® Chart and Word, SuperCalc3™, AutoCad™, and dozens of other programs.

"Including Microsoft Flight Simulator, now Hercules compatible!

"Oh, and don't forget that a parallel printer port is standard on the Hercules Graphics Card, not an extra cost option.

"Now, if you're worried about buying a new product that hasn't had all the bugs

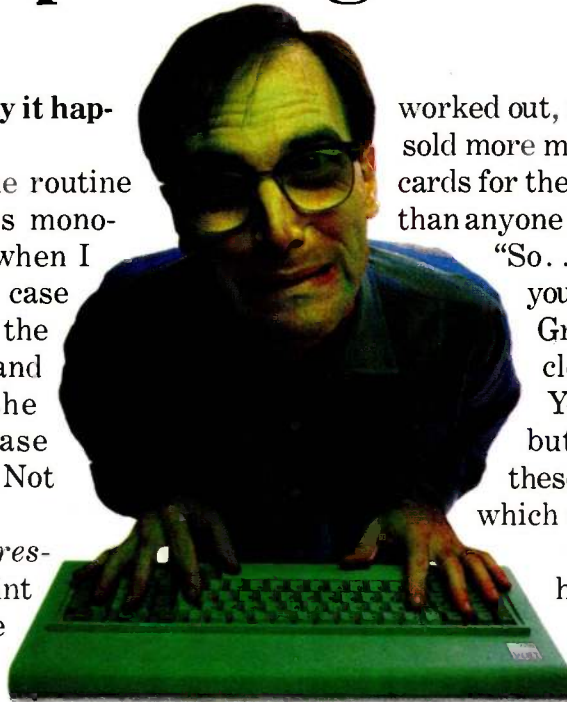

worked out, relax. Hercules has sold more monochrome graphics cards for the IBM® PC, XT™ and AT™ than anyone else in the world.

"So . . . you're convinced that you should buy a Hercules Graphics Card. Now, steer clear of cheap imitations. You may save a few bucks, but you won't get all of these five essential features which only Hercules has:

"1) A safety switch that helps prevent damage to your monitor, 2) the ability to keep an IBM or Hercules Color Card

in your system, 3) the ability to use the PC's BASIC to do graphics, 4) a Hercules designed chip that eliminates 30% of the parts that can go wrong, and 5) a two year warranty, because we think reliability is something you should deliver and not just talk about."

Call 1-800-532-0600 Ext 408 for the name of the Hercules dealer nearest you and we'll rush you our free info kit.

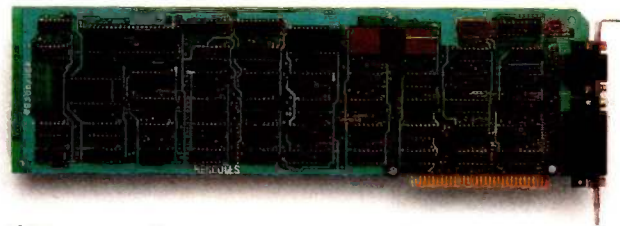

## Hercules. We're strong on graphics.

Address: 2550 Ninth St., Berkeley, CA 94710 Ph: 540-6000 Telex: 754063 Trademark/Owners: Hercules/Hercules Computer Tech; IBM, XT, AT/IBM; Lotus 1-2-3, Symphony/Lotus Development; Framework/Ashton-Tate; Microsoft/Microsoft; pfs:Graph/Software Publishing; SuperCalc 3/Sorcim-IUS; AutoCad/AutoDesk.



p-System. I am quite happy with my TRS-80 at home. Recent clamorings by my offspring for Macintoshes coincided with the IIe problems. Both kids and their friends understand why I hesitated then made another choice for them.

This is my first experience with an Apple. I have no personal need to make it more detailed or extended in time. I find the documentation to be shallow, the I/O implementation crude (even when measured against 1980 standards), and the service haphazard. I more carefully assess what Apple owners and users have to say about their machines.

My feelings might not be quite so strong if only the hardware or the documentation had been screwed up. The infant mortality in the hardware combined with documentation hassles have heavily underscored the flaky sales support and the mediocrity of the operating system and language. Color Apple with a worm in it!

By contrast, Digital Equipment Corporation provides us with singularly outstanding support for our Rainbow. That system is supported by an excellent certification

program for third-party software. If DEC says that a particular package such as CTOS or Lotus 1-2-3 will run on the Rainbow, you can bet the company has tried it and within the range of their tests has found no implementation bugs. Our IBM Displaywriters use CP/M-86 and UCSD p-Systems that have outstanding support from D/R and Softtech as well as IBM. My TRS-80 came with a language reference manual and DOS manual as well as owners/operators manuals. The additional technical reference manuals were readily available from the dealer at nominal charges. Every Tandy manual was well written, pretty much stand-alone, and had a good reference appendix. The indexes and table of contents did not contain errors in page numbers.

Just out of curiosity, I priced documentation at our local Commodore dealer and at a nearby Tandy Computer Center. Much of it is free with the system, and the prices on the remainder are moderate—what's more, it's readily available.

PAUL M. HINE  
San Diego, CA

When a manufacturer sells a computer and withholds information on that computer, the computer's worth is in direct proportion to the amount of information one receives. No information means the computer is worthless. A computer is unique in this regard. If you buy a car, someone can always drive it or fix it without a shop manual. Try programming a computer to do something you want it to do without information on the I/O ports or the memory map. Try getting a computer fixed that no one has schematics for. Of course, somebody can always charge you three or four hundred dollars and replace the entire main circuit board when only a twenty-cent chip may be defective. You don't need a schematic to do that. After all, the manufacturer makes a lot of money selling you a new circuit board for \$400 when you don't need one.

I have an Apple IIc. I was originally interested in the compact Apple IIc because of its built-in disk drive and its ability to be powered from a 12-volt car battery. Apple computer promised some day Real

(continued)

2 YEAR WARRANTY ON CARD AND DRIVE

# 10 Mbyte

## SATISFACTION GUARANTEED

Suggested retail price \$1095

**\$945** SPECIAL SALE PRICE

100% refundable within 30 days.

For IBM PC\* & compatibles. 2 Years Warranty on disk drive and controller card.

- Half-height drive with controller card
- Low error rate
- Low power
- High performance and reliability
- Easy installation

**20 Mbyte for \$1,495.**

**TO ORDER SEND CHECK OR MONEY ORDER TO:**

**Linde Technology, Inc.**  
8820 S. Sepulveda Blvd.,  
Suite 204  
Los Angeles, CA 90045

**OR CALL TOLL FREE:**

1 (800) 227-2400 ext. 974

In California call

1 (800) 772-2666 ext. 974

Visa and MasterCard accepted.

California residents add 6½% sales tax.

**For dealer inquiry and more information call: (213) 215-9484**

\*IBM is a registered trademark of International Business Machines Corp.

**Yes, send me more information on:**

- 10 Mbyte Disk Drive  
 20 Mbyte Disk Drive

**Linde Technology, Inc.**

8820 S. Sepulveda Blvd., Suite 204  
Los Angeles, CA 90045

NAME \_\_\_\_\_

ADDRESS \_\_\_\_\_

CITY \_\_\_\_\_ STATE \_\_\_\_\_ ZIP \_\_\_\_\_





# A few smart reasons to buy our smart modem:

Features	Ven-Tel 1200 PLUS	Hayes
1200 and 300 baud, auto-dial, auto-answer	Yes	Yes
Compatible with "AT" command set	Yes	Yes
Can be used with CROSSTALK-XVI or Smartcom II software	Yes	Yes
Regulated DC power pack for cool, reliable operation	Yes	<b>No</b>
Eight indicator lights to display modem status	Yes	Yes
Speaker to monitor call progress	Yes	Yes
Attractive, compact aluminum case	Yes	Yes
Two built-in phone connectors	Yes	<b>No</b>
Compatible with The Source and Dow Jones News Retrieval	Yes	Yes
Unattended remote test capability	Yes	<b>No</b>
Phone cable included	Yes	Yes
Availability	Now	
<b>Price</b>	<b>\$499</b>	<b>\$699</b>

The Ven-Tel 1200 PLUS offers high speed, reliable telecommunications for your personal computer or terminal. Whether you use information services or transfer data from computer to computer, the Ven-Tel 1200 PLUS is the best product around. Available at leading computer dealers and distributors nationwide.

Also from Ven-Tel: internal modems for the IBM and HP-150 Personal Computers with all of the features of the 1200 PLUS.

**You choose. The Ven-Tel 1200 PLUS—the smartest choice in modems.**

**Ven-Tel Inc.**  
2342 Walsh Avenue  
Santa Clara, CA 95051  
(408) 727-5721

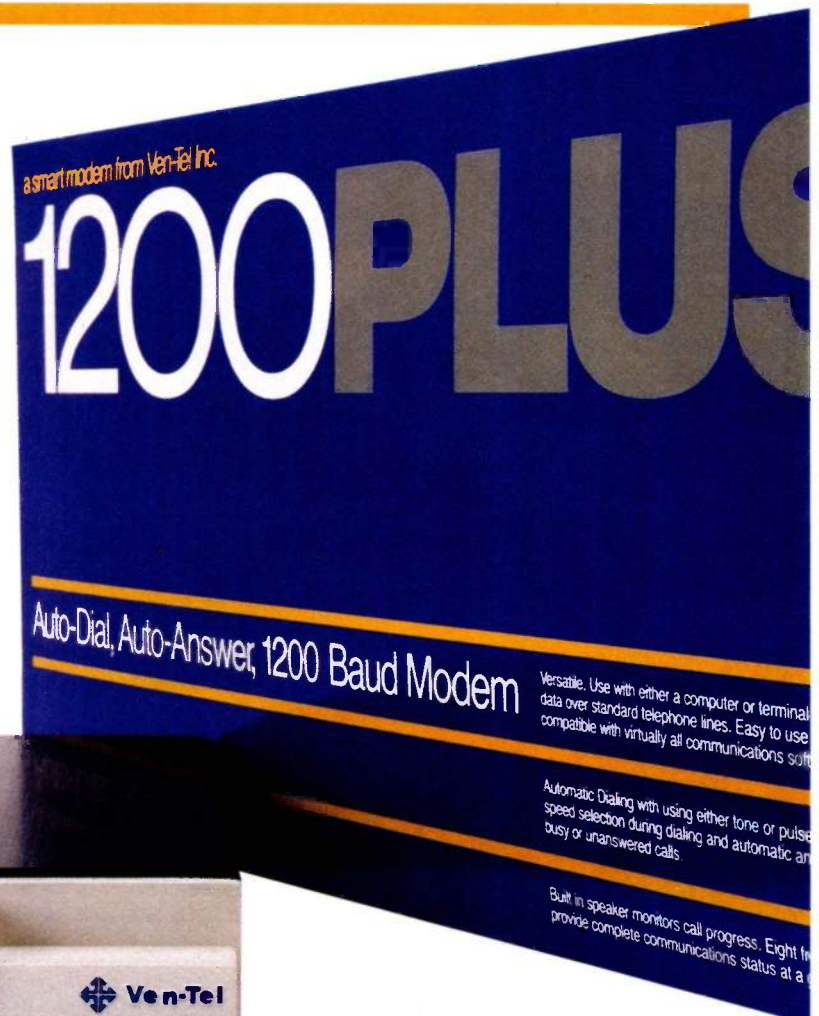

Crosstalk is a trademark of Microstuf; Hayes and Smartcom II are trademarks of Hayes Microcomputer Products.



# SIDEKICK





# Borland's SideKick Software Product of the Year

SideKick is InfoWorld Software Product of the Year. It won over Symphony. Over Framework. Over ALL the programs advertised in this magazine. Including, of course, all the "fly-by-night" SideKick imitations. **SideKick . . . Simply the best.**

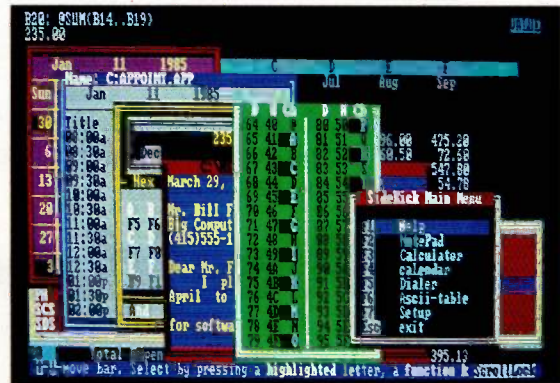

Here's SideKick running over Lotus 1-2-3. In the SideKick Notepad you'll notice data that's been imported directly from the Lotus screen. In the upper right you can see the SideKick Calculator.

All the SideKick windows stacked up over Lotus 1-2-3. From bottom to top: SideKick's "Menu Window", ASCII table, Notepad, Calculator, Appointment Scheduler/Calendar, and Phone Dialer. Whether you're running WordStar, Lotus, dBase, or any other program, SideKick puts all these desktop accessories instantly at your fingertips.

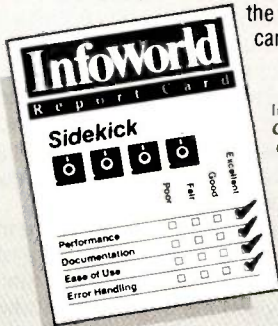

InfoWorld Report Card 1984 by Popular Computing, Inc., a subsidiary of CW Communications Inc. Reprinted from InfoWorld, 1060 Marsh Road, Menlo Park, CA 94025.

**Jerry Pournelle, BYTE:** "If you use a PC, get SideKick. You'll soon become dependent on it."

**Garry Ray, PC Week:** "SideKick deserves a place in every PC."

**Charles Petzold, PC Magazine:** "In a simple, beautiful implementation of WordStar's block copy commands, SideKick can transport all or any part of the display screen (even an area overlaid by the notepad display) to the notepad."

**Dan Robinson, InfoWorld:** "SideKick is a time-saving, frustration-saving bargain . . ."

**BORLAND INTERNATIONAL** Software's Newest Direction  
4113 Scotts Valley Drive  
Scotts Valley, California 95066  
TELEX: 172373

## SIDEKICK

NOT COPY-PROTECTED

Available at better dealers nationwide. Call (800) 556-2283 for the dealer nearest you. To order by Credit Card call (800) 255-8008, CA (800) 742-1133

Yes, I want the Best.  
Please send me SideKick!

SideKick Copy Protected  
Quantity: \_\_\_\_\_ at \$54.95

SideKick Unprotected  
Quantity: \_\_\_\_\_ at \$84.95\*

Name: \_\_\_\_\_

Shipping Address: \_\_\_\_\_

City: \_\_\_\_\_ Zip: \_\_\_\_\_

State: \_\_\_\_\_ Telephone: \_\_\_\_\_

Amount: (CA 6% tax) \_\_\_\_\_

Payment: VISA MC BankDraft Check

Credit Card Expir. Date: \_\_\_\_\_

Name on Card: \_\_\_\_\_

Card #: \_\_\_\_\_

S 15

COD's and Purchase Orders WILL NOT be accepted by Borland. California residents: add 6% sales tax. Outside USA: add \$10 and make payment by bank draft, payable in US dollars drawn on a US bank.

Symphony, Lotus & Lotus 1-2-3 are trademarks of Lotus Development Corp. dBase & Framework are trademarks of Ashton-Tate. WordStar is a trademark of Micropro International Corp. SideKick is a trademark of Borland International.



# Planning to deduct your PC? The IRS just made it tougher.

According to the Tax Reform Act of 1984, if you want to take a business deduction for your personal computer, you now must prove you use it more than half the time for business. And that proof must be in the form of a daily log.

You can waste valuable time each day recording your use. Or you can use WorkLog to do the job in seconds.

Considering how much your time is worth, isn't \$59.95 a worthy investment?

To order call (206) 526-0711. Or ask for our brochure that describes the power and elegance of this state-of-the-art software. WorkLog makes it easy.

## WorkLog

The essential time-saver.

*For IBM-PC, -XT, -AT, and compatibles. Requires 128k and any version of PC-DOS.  
WyssWare/5207 Ravenna Ave. N.E./Seattle, WA 98105*

## LETTERS

Soon Now to have a liquid-crystal display that would draw very little power and operate from a battery.

The first snag I ran into was when I tried to find out from the Apple IIc manuals what the pin connections were for the nonstandard serial-port connector. No luck. Nowhere in the manuals that came with the computer could I find the connections for the serial interface.

The next thing I did was call Apple long distance. I was put on hold for five minutes listening to some music. Needless to say, it was not high-fidelity. Finally, Patty came on the line and told me I had to call another long-distance number in another part of the country. Get this, I am in L.A. Well, I called that number, and an answering machine came on the line telling me to leave my name and phone number and my question and they would get back to me within 24 hours. Since I am in and out of the office all day and no one else at my office is knowledgeable enough to ask intelligent technical questions about RS-232C interfaces, that might be a problem. If Apple personnel happened to call back while I was out of the office, at least another 24 hours would go by before I could ask the first question. At this rate, a year or more would go by before I could write this assembly-language program to talk to the Apple IIc. The answering machine also advised me to contact my nearest dealer.

We have a lot of Apple dealers here in L.A. I contacted three of them. None of them knew anything more about it than I did. One advised me to go to all of the bookstores and get a book on the Apple IIc. I did just that; in fact, I bought three books. So far, I have spent at least 40 hours of my valuable time, \$40 on books, and \$50 on long-distance phone calls. I now know the pinouts on the connectors, but that is all the useful information those three books could tell me. Absolutely nothing else of any value. No memory locations for setting up the RS-232C interface chip or how to write code to send or receive data from the RS-232C interface in assembly language or BASIC. Nothing.

Has Apple management grown so greedy that it doesn't want people to buy any device to hook up to an Apple IIc unless they buy it from Apple? Does Apple want anyone to write and sell software other than Apple Computer? Is Apple management so paranoid that someone will copy the IIc that it is afraid to document the ROM? Why does Apple have an army of lawyers ready to sue

*(continued)*

© 1985 Best Western International

## The right place at the right price.



Make reservations at any Best Western,  
see your travel agent, or call

1-800-528-1234.

"World's largest chain of independently owned and operated hotels, motor inns, and resorts"



# NEW PRODUCT NEWS FROM TELETEK

**Systemmaster II.** Responding to market demand for speed and increased versatility, Teletek is proud to announce the availability of the next generation in 8-bit technology — the new Systemmaster II! The Systemmaster II will offer two CPU options, either a Z80B running at 6 MHz or a Z80H running at 8 MHz, 128K of parity checked RAM, two RS232 serial ports with on-board drivers (no paddle boards required), two parallel ports, or optional SCSI or IEEE-488 port. The WD floppy disk controller will *simultaneously* handle 8" and 5¼" drives. A Zilog Z-80 DMA controller will provide instant communications over the bus between master and slave. Add to the DMA capability a true dedicated interrupt controller for both on-board and bus functions, and the result is unprecedented performance.

Systemmaster II will run under CP/M 3.0 or TurboDOS 1.3, and fully utilize the bank switching features of these operating systems.

## TELETEK

4600 Pell Drive  
Sacramento, CA 95838  
(916) 920-4600  
Telex #4991834  
Answer back — Teletek

Inquiry 382

**SBC 86/87.** As the name indicates, Teletek's new 16-bit slave board has an Intel 8086 CPU with an 8087 math co-processor option. This new board will provide either 128K or 512K of parity checked RAM. Two serial ports are provided with individually programmable baud rates. One Centronics-compatible parallel port is provided. When teamed up with Systemmaster II under TurboDOS 1.3, this 5MHz or 8MHz multi-user, multi-processing, combination cannot be beat in speed or feature flexibility!

**Teletek Z-150 MB.** Teletek is the first to offer a RAM expansion board designed specifically for the Z-150/Z-160 from Zenith. The Teletek Z-150 MB is expandable from 64K to 384K. Bring your Z-150 up to its full potential by adding 320K of parity checked RAM (or your IBM PC, Columbia, Compaq, Corona, Eagle, or Seequa to their full potential). The Teletek Z-150 MB optionally provides a game port for use when your portable goes home or a clock/calendar with battery backup!

Evaluate the Systemmaster II, SBC 86/87 or Teletek Z-150 MB for 30 days under Teletek's Evaluation Program. A money-back guarantee is provided if not completely satisfied! All Teletek products carry a 3-year warranty.

(Specifications subject to change without notice.)

IN BRAZIL: Danvic S.A  
R. Conselheiro Nebias, 1409  
01203 São Paulo, Brazil  
Tel: 221-6033 (P A B X)  
Telex: 1123888 CICP BR

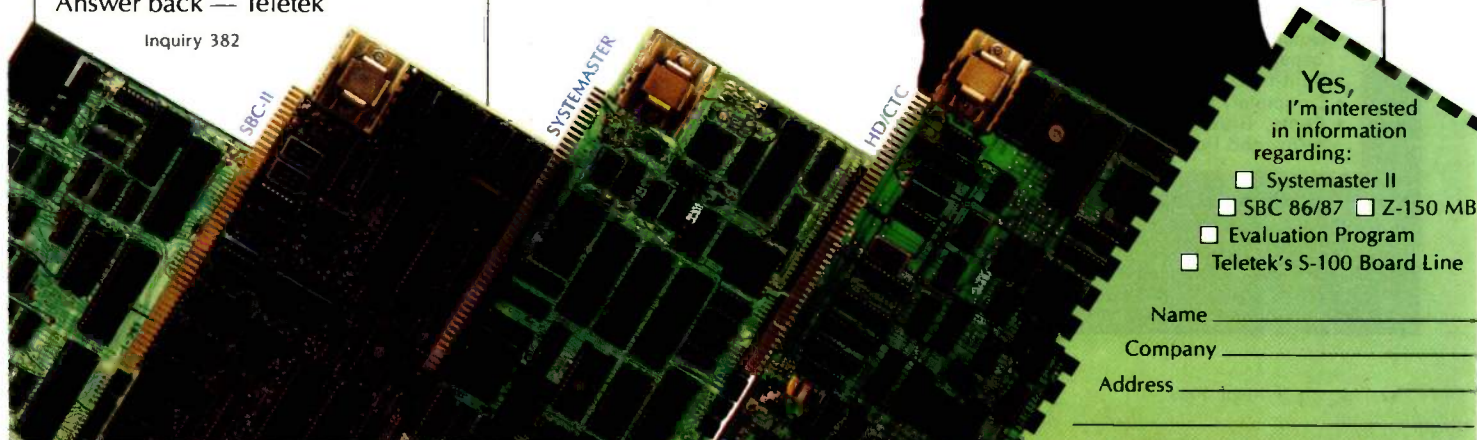

Yes, I'm interested in information regarding:

- Systemmaster II
- SBC 86/87  Z-150 MB
- Evaluation Program
- Teletek's S-100 Board Line

Name \_\_\_\_\_

Company \_\_\_\_\_

Address \_\_\_\_\_



anyone if the company even hints of manufacturing a machine that will run Apple software? Hasn't Apple management learned that the more information you supply in the box with the computer, the less money it takes to support the product? Is the well-documented IBM PC outselling Apple everything?

One would think that Apple had learned its lesson with the Apple III. The Apple

III came with no real documentation as well. We all know what happened to the Apple III. From what I have seen of the Macintosh documentation, the Mac is in the same boat. I would not use a Mac if you gave me one.

The next problem I found was that the RS-232C data-transmission rate in the Apple IIc was off frequency by just enough to prevent the RS-232C from working prop-

erly. Apparently Apple divided down the microprocessor clock crystal to save the \$3 cost of a data-transmission rate crystal. If the IIc had a schematic in the owners manual, any competent computer technician would know about the transmission-rate problem before purchasing the computer. I guess that is one of the reasons Apple did not put a schematic in the owners manual in the first place. The man on the Apple hotline told me to take the IIc into any Apple computer dealer, who would fix it at no cost. None of the three dealers I contacted had heard of this repair program, nor would they do it at no cost.

If you buy an Apple other than the IIc, you need your head examined.

A Commodore 64, although it costs much less than the Apple IIc, is worth at least 100 times as much because you can use it. You can get a vast quantity of programming and technical information on the Commodore 64 in great detail. Information that is necessary to program and interface all the things that people need a microcomputer for.

I now own a \$1200 paperweight.

PAUL LAMAR  
Redondo Beach, CA

### WHERE ARE APPLE'S MANUALS WHEN YOU NEED THEM?

.....  
Last night I tried to order an *Apple IIc Reference Manual* at my local dealer. I was told that the manual costs \$50, could be ordered only in boxes of five, and if I would order five that they would be glad to handle my order. Of course I thought that I would go elsewhere.

When I arrived home, some back issues of *Apple Assembly Line* had come in the mail. I discovered that Texas Apple dealers had the same policy and that it extended to ProDOS and IIe manuals as well. Eventually I learned that these manuals could be ordered by mail from a dealer in New York (212-512-4100).

Providing access to the fundamental hardware manuals for the machine is the most minimal level of dealer support possible. Perhaps K-Mart does not provide access to manuals for the computers it sells, but every self-respecting computer dealer must do this.

The poor availability of these manuals must in part stem from the fact that they are seen as manuals only a hacker or professional software developer would want or need. Apparently Apple believes that its customers are not likely to grow in

(continued on page 436)

## Graphics Takes A Quantum Leap Forward!



### THE INOVION PERSONAL GRAPHICS SYSTEM FEATURES:

- The most advanced color mapping capabilities available.
- 250,000 simultaneously displayable colors.
- A palette of 2.1 million colors.
- Frame Grabber/Digitizer to capture TV, VCR or Video Camera pictures.
- Quality three-dimensional texture capabilities.
- Built-in Icon/Menu software.
- Completely Mouse/Trackball driven.
- Fonts, Brushes, Microscope, Patterns, and Rotations.
- A complete stand alone system.
- A 19" enhanced color monitor.
- 780K Graphics Memory.
- 512 x 480 pixel display with 24 bits per pixel.
- RS232C port allows access to all system functions and memory.
- NTSC composite video and NTSC RGB signal.
- 1-year warranty on graphics generator and 90-day warranty on enhanced monitor.
- Special introductory 30-day satisfaction guarantee.
- **Complete system for \$4,495**

**INOVION**

195 East Gentle Street  
Layton, Utah 84041  
(801) 546-2850



# F·I·X·E·S A·N·D U·P·D·A·T·E·S

## UPDATE

### C Changes Quickly

Our December 1984 article "C-Language Development Tools" by G. Michael Vose (page 119) brought several new C interpreter vendors out of the woodwork. We also learned of a name change for one of the article's previewed products.

The Safe C Compiler from Catalytix Corporation (55 Wheeler St., Cambridge, MA 02138) is now called the Safe C Runtime Analyzer. The product's functions have not changed, only the name, to distinguish it from production compilers.

Catalytix also announced the release of its Safe C Standalone Interpreter. The interpreter is a complete C implementation that allows the use of any text editor and source-code formatting or cross-referencing utilities. Code interactively written and debugged within the interpreter can subsequently be compiled into executable files, using any compiler that conforms to the Kernighan & Ritchie (K&R) C-language specification. Currently available for the IBM PC and other MS-DOS machines, the Safe C Standalone Interpreter sells for

\$400. A Macintosh version is under development.

Age of Reason Company (318 East 6th St., New York, NY 10003) has announced the availability of RUN/C—a C interpreter for MS-DOS computers. Distributed by Lifeboat Associates (1651 Third Ave., New York, NY 10128), RUN/C costs \$150.

RUN/C features a built-in line editor similar to the Microsoft BASIC editor, plus the capability to use an outside editor. You can even compile your C programs from *within* the RUN/C interpreter. RUN/C fully implements the K&R specification for C, but this interpreter has a limit of 2000-line programs.

Gimpel Software (3207 Hogarth Lane, Collegeville, PA 19426) markets a C interpreter called C-terp, also for the IBM PC and work-alikes using MS-DOS 2.x. C-terp costs \$300; a demonstration disk is available for \$45. C-terp also fully implements the Kernighan & Ritchie C-language specification, includes an editor, and offers batch-mode operation. C-terp sup-

ports small or large memory models.

Lastly, Computer Innovations (980 Shrewsbury Ave., Tinton Falls, NJ 07724), purveyors of the C86 C Compiler, offers Introducing-C, a C interpreter designed to help the programming novice learn C as her/his first language.

Introducing-C does not fully implement the K&R C specification, but it documents the differences in a 10-page appendix. For example, Introducing-C does not support multidimensional arrays, `#defines`, struct and union data structures, the typedef declaration, and several other components of C. Future revisions to the interpreter will provide many of the features currently missing. Introducing-C's interpreter is upward-compatible with the C86 compiler.

Computer Innovations claims that Introducing-C is suitable for learning structured programming and most of C and for developing "medium-sized, non-scientific programs." Available for the IBM PC, Introducing-C costs \$95.

## FEEDBACK

### Printer Buffer Messaged

In the June 1984 BYTE there were several errors in the article "Build a Printer Buffer" by John Bono (page 142). Richard Carlsen from Upton, New York, built the printer buffer, encountered and overcame some difficulties, and wrote us about his travails. Here are some excerpts from his letter:

I noticed corrections in the November 1984 BYTE on the ROM listings (page 34), but I haven't seen any hardware updates, so here are some suggestions for improving John Bono's project.

In listing 1 on page 453 (June BYTE), line 13 should show EQU OFFFFH (zero, not "oh") and line 17 should be A, OFFH.

In the schematic on page 450, IC 14 is incorrectly labeled 74LS00 at the top of the page. IC 14 is a 74LS367A. (I should also note that I tried both the 74LS367s and 74LS367As, and they both work fine.)

Input pins 4 and 10 of IC 14 should be tied high or at least not left floating as those sections are unused. Floating leads are not good practice and could cause some occasional errors.

On the middle left on page 450 the data lines are in inverse order. D0 should be D7, D6 should be D1, and so on until D7 is D0. They are labeled correctly at the Z80 and 2716.

A useful item to add is a reset switch across the 68- $\mu$ F (microfarad) cap on pin 26 of the Z80. I added a 47-ohm resistor in series with the switch so discharge of the 68- $\mu$ F cap is a little more gentle.

At the lower right on page 452 you'll find IC 13 and IC 24 (printer acknowledge FF). A signal is missing (G6) at IC 13, pin 9. Remove pin 4 of IC 24 from +5 V. Leave IC 24, pin 2 connected to +5 V. Now connect pin 4 of IC 24 to pin 9 of IC 13. This

will allow D306 at line 26 on page 453 to reset the printer's acknowledge flip-flop.

On page 452, data lines, strobe, busy, and acknowledge to the left of IC 9 should be labeled "TO COMPUTER." At the right of IC 15 they should be labeled "TO PRINTER."

Be aware that all 4164 RAM chips are not created equal. They come in different speeds usually designated by a -2 or -3 suffix. I have had no trouble with either. However, some companies require 128 refresh cycles over a 2-microsecond period. Others may require 256 refresh cycles over a 4-microsecond period. I used NEC 4164-2 chips and Mostek 4564-2 chips successfully, both of which require 128 cycles. Others requiring 256 refresh cycles gave me occasional errors.

Another pointer: Watch the power wir-

(continued)



# MidWest Micro-Peripherals

Save with Confidence

Let us earn your trust as we  
have that of others, such as:

Goodyear • General Motors • US Navy • etc.  
Ask for: Sue, Marianne, Kathy, Tim, Nick or Roger

List Our Price

### PRINTERS

Star Gemini 10X (120 CPS)	\$399	\$219
Star Gemini SG-10 (NEW)	299	229
Star Gemini 15X	549	349
Star Gemini SG-15 (NEW)	499	379
Star Delta 10 / Delta 15 (160 CPS)		SCALLS
Star Radix 10 / Radix 15 (200 CPS)		SCALLS
Epson RX 80 (100 CPS)	399	229
Epson RX-80 F/T + Series (NEW)	499	289
Epson FX-80 + Series (NEW)	689	389
Epson FX-100 + Series (NEW)	995	599
Epson JX 80 Color	799	SCALLS
Epson LQ 1500 (200 CPS)	1495	SCALLS
Okidata 92P (80 Col, 160 CPS)	599	379
Okidata Apple Imagewriter Compatible	699	449
Okidata 93P (136 Col, 160 CPS)	999	599
Okidata Pacemark 2410P (150 CPS)	2495	SCALLS
Panasonic 1091 (120 CPS)	499	299
Panasonic 1090, 1092, 1093		SCALLS
Toshiba 1340P (54 CPS)	985	769
Toshiba 1351P (100 CPS)	1855	1299

### DAISYWHEEL PRINTERS

Brother HR-15XL (17 CPS)	599	359
Brother HR-25 (23 CPS)	895	619
Brother HR-35 (32 CPS)	1245	839
Silver Reed EXP 400	399	279
Silver Reed EXP 500 (16 CPS)	599	359
Silver Reed EXP 550 (19 CPS)	699	439
Silver Reed EXP 770 (36 CPS)	1295	829
Star PowerType (18 CPS, Bi-Dir)	499	328
Juki 8100 (18 CPS, Bi-Dir)	599	399
Juki 6300	999	749
Daisywriter 2000 (40 CPS)	1495	899

### IBM PC SYSTEMS

PC's and PCXT's

Complete Systems  
Call and Save!



### EXPANSION CARDS

AST Six Pac Plus 64K, S/PIC+S/W	395	269
QUADRAM Complete Line		SCALLS
MEMORY CHIP kit-64K 150ns-9 chips	99	49

### DISK DRIVES

Teac Half Heights	299	149
Teac 2 Drive Kit - Complete	499	299
Tandon 100-2 (IBM Standard)	399	159
Maynard - 10 Meg. Internal Drive	1395	SCALLS
Maynard 20MB Tape Backup	1895	SCALLS
Tallgrass Drives w/Tape Backup		SCALLS
Turbo 10 10 MB Internal Hard Drive		SCALLS

### MODEMS

Hayes Smartmodem 300	289	219
Hayes Apple 2c Modem Pkg w/Software	399	269
Hayes Apple 2E Modem Pkg w/Software	399	239
Hayes Smartmodem 1200	699	469
Hayes Smartmodem 1200B w/IBM Software	599	399

### MONITORS

Amdek 300, 310; Color 500, 600, 700		SCALLS
Princeton Graphics 4 x 12 Maxi 2		SCALLS

### SOFTWARE

Lotus 1-2-3, Symphony & Hundreds More		SCALLS
---------------------------------------	--	--------

### SANYO SYSTEMS

Complete Sanyo  
Systems  
Lots of  
Free Software



LOW  
AS  
\$899

### OUR PRICE COMMITMENT

MidWest will try in good faith to beat  
any nationally advertised price.

Prices subject to change and type errors



FREE CARD USE



Call Today!

Information - Ordering  
1-800-423-8215

In Ohio 1-800-321-7731

CUSTOMER SERVICE (513) 663-4992

CASH PRICES: Cert. Check, Money Orders, VISA or MC  
CODs (Add \$5) AMEX (Add 4%) P.O.s (Add 5%)

MidWest Micro-Peripherals  
(Division of Infotel, Inc.)  
135 South Springfield St.  
St. Paris, Ohio 43072

## FIXES & UPDATES

ing to these RAM chips. Pin 16 is ground and pin 8 is +5 V. This is not as you would usually expect with 16-pin chips, and I sure got caught wiring these wrong.

On my unit I used a crystal oscillator at 1 MHz hooked to pin 6 of the Z80. If you do this, a 1K pull-up resistor or so at pin 6 will ensure that the "1" levels are 4.0 to 4.5 V as the Z80 requires there.

Not all printers and computers handle Centronics interfacing in the same manner. My Kaypro 2, for example, does not use the ACK signal. The buffer works fine with my Okidata 92 with the Kaypro using just the busy signal. Your computer may also use other signals such as the "Paper Out" line. Consult your printer and computer manuals or dealer about your printer and computer parallel ports before starting this project. In most cases you should be able to work things out with the available signals supplied by the buffer.

Some new ideas have been suggested by other readers of this article for improving the project and I'll pass them on.

1. Multiple dumps by the use of a repeat printout switch would be useful. This

would allow extra copies of a document to be printed from the buffer's memory without disturbing the computer. Recoding of the RAM and some minor hardware additions would be necessary.

2. Self-check of memory. This would also require some additional ROM coding.

3. A printer code preloader, which would let you change printer functions (such as compressed print mode, character pitch, or near letter quality) by sending the printer prewritten codes stored in the printer-buffer ROM. These could be selected by thumb-wheel switch and entered to the printer by a push-button switch using the remaining port 7 select at G7 pin 7 of IC 13 as a means of addressing this feature.

If anybody has completed these or other features, please write in to BYTE and let the rest of us in on it. This is a great project when it's working. I would like to thank John Bono for writing this article and for his patience with my questions. I wish also to thank other readers for their time on the phone and exchange of ideas, and BYTE for acting as the intermediary.

## BYTE'S BUGS

### Communication on Modem Gets Garbled

In the What's New section of the *Guide to the Apple Personal Computers*, a special supplement to the December 1984 BYTE, we inadvertently published the wrong picture and supplied some incorrect information.

The picture on page A136 does not depict Multi-Tech Systems' internal modem card for the Apple II, but rather it shows Multi-Tech Systems' MultiModem 1200/300-bps external modem.

The single-board MultiModem IIe, shown here, fits entirely inside Apple II series computers and does not require a serial card. It operates at 110/300 bps, features auto-answer and auto-dial, and comes with communications software. The list price is \$229, which includes free-time and subscription discounts to a number of database networks, such as Dow Jones News/Retrieval Service and the Instant



Yellow Page Service.

The MultiModem 1200/300 stores up to six 31-digit telephone numbers, detects dial and busy tones, and can continuously redial busy numbers. It lists for \$549.

Both modems come with two-year warranties. Multi-Tech Systems Inc. is headquartered at 82 Second Ave. SE, New Brighton, MN 55112, (612) 631-3550.

### Corrections from Commodore

The model number of Commodore's new 128K-byte computer was incorrectly stated in the February What's New section (page 40).

The computer is known as the Commodore C128. Also, it uses the 8502 microprocessor to run Commodore software

and its Z80 coprocessor runs at 4 MHz.

The article also described a new high-speed disk drive that works with both the C128 and the C64. In its C64 mode, the drive transfers data at 300 cps. While in its C128 or CP/M modes, the data rate is 5200 cps. ■



# DATA SAFE by AFTTEK

## THE HIGH PERFORMANCE RANDOM ACCESS TAPE BACK-UP ! THE NEXT GENERATION OF TAPE DRIVES.

### DATA SAFE STAND ALONE UNIT

- C/W cable (chains off DB-37 connector on rear of computer)
- Has its own booster power supply
- Is easy to install

### DATA SAFE INTERNALLY MOUNTED UNIT

- Is daisy chained off the existing floppy controller
- Requires IBM plug compatible bus and internally selected 4 channel select floppy disk controller
- No additional slots needed

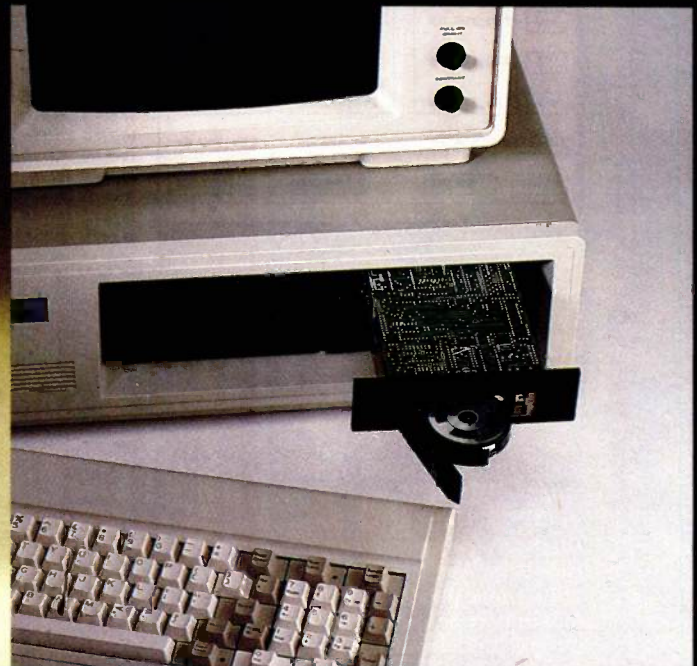

- For IBM XT's and compatibles
- Incorporates main frame micro reel technology
- Random access
- Use of PC DOS and MS DOS commands (tree, path, etc.)
- MTBF - 20,000 hrs.
- Reliable (150,000 load and unload failsafe tested by an independent laboratory)
- C/W software device drivers
- C/W cable
- Extremely fast back-ups
- 10 meg available only
- Priced less than **50% less** than the nearest rival
- **ONE YEAR WARRANTY**



The **DATA SAFE** uses industry standard 1/4" tape on a self threading 2.2" spool

1050 Clinton St.  
Buffalo, New York  
14206

Tel.: (716) 694-5366 Telex: 916428

Inquiry 17



**Business Machines Inc.**

PRIME DEALER DISTRIBUTOR TERRITORIES AVAILABLE. OEM CALLS INVITED.

762 Gordon Baker Rd.  
Willowdale, Ontario  
Canada M2H 3B4  
Tel.: (416) 497-0531 or toll free  
1-800-268-5412 Telex: 06-986133

IBM IS THE REGISTERED TRADE MARK FOR INTERNATIONAL BUSINESS MACHINES INC.



# You have wanted to do something, but the door has been closed . . .

	REGION 1	REGION 2	REGION 3
W1	\$12,779.22	\$15,175.90	\$9,765.88
W2	\$10,253.89	\$13,020.19	\$13,786.33
W3	\$20,145.50	\$22,998.00	\$14,995.43
W4	\$6,778.05	\$43,332.00	\$25,790.00
TOTAL	\$49,956.66	\$94,526.09	\$64,337.64
% GOAL	99.9%	94.5%	107.2%

Helix is a data-based system, so that once you enter information you can use it for anything – reports, lists, analyses, mail merge printouts, or even relational look-ups to other data-bases within Helix.

**Requires:** an external drive or hard disk  
**Runs on:** 512K Macintosh • Lisa with MacWorks  
**Supports:** Hard disks • Keypad • 15" Imagewriter  
**Includes:** Helix Program disk • Helix Guided Tour disk • Helix Resource/Work disk • User Manual • 18-ring project binder • Reference pad for custom documentation • Registration card for support & updates  
**Offers:** Modeless input, interactive query, editing, & report generation • Text-formatting • Calculations between fields & across records • Object-oriented, icon-based design • Relational Look-ups • List management • Mail merge • Clipboard & ASCII file transfer • Special Template tools for form design • User defined, automatically updated Indexes • Unrestricted length & number of fields • Complete printing options • Vertical and horizontal autoscroll • Visual building blocks for arithmetic, date, text & Boolean operators, functions, & values.

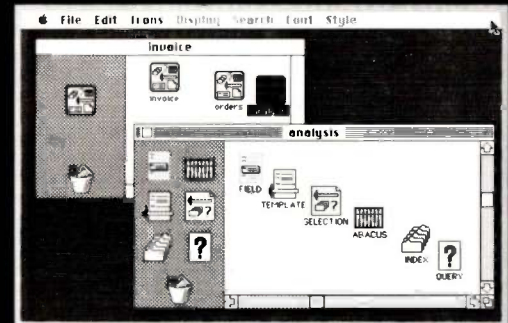

The full functionality of Helix lies within its six basic icons. You can "learn by doing" with Helix, since it does not get in your way with imposed structure or restrictions. You don't have to worry about parameters, command codes, or "modes".

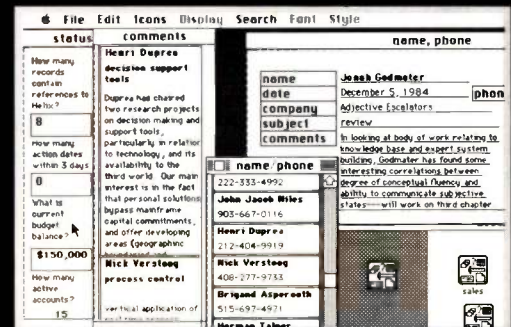

All open windows are updated automatically. Used here to simultaneously enter project notes, see synopses, get phone numbers, and display important "global" statistics.



See us at  
 Georgia World Congress Center  
 Atlanta, Georgia  
 Sunday-Wednesday  
 March 31 to April 3, 1985  
 10 am to 5 pm daily  
 Booth 1427

© 1985 Odesta Corp.  
 Odesta Helix is a trademark of Odesta Corporation  
 Apple, Lisa, and Macintosh are trademarks of  
 Apple Computer, Inc.



# Odesta Helix opens the door.

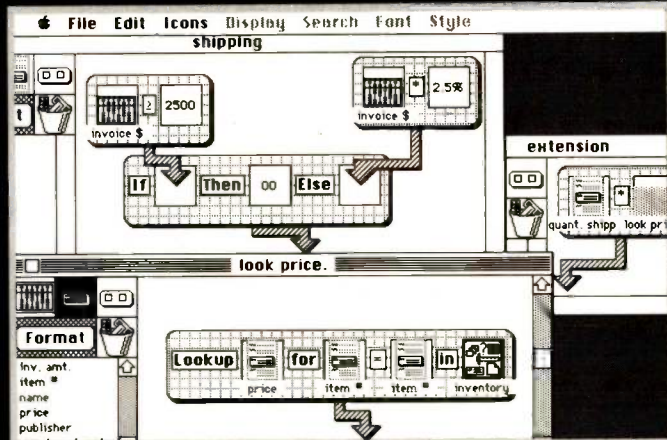

Now, you don't have to learn a programming language or worry about "relational algebra". Except for the three numbers you see, no typing was used to create these calculations: "If invoice amount is equal to or greater than \$2500, then don't charge for shipping, otherwise charge 2.5% of the invoice amount" . . . "Look up the price for the item in the inventory data-base" . . . "Multiply the item's price by how many were shipped" . . .

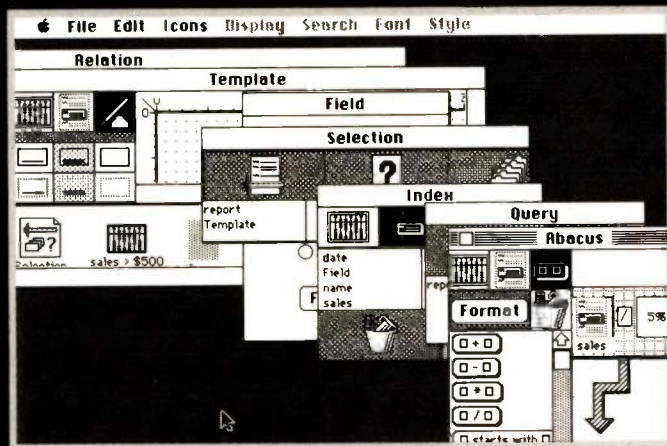

Helix combines powerful functions with a design that gives you direct control.

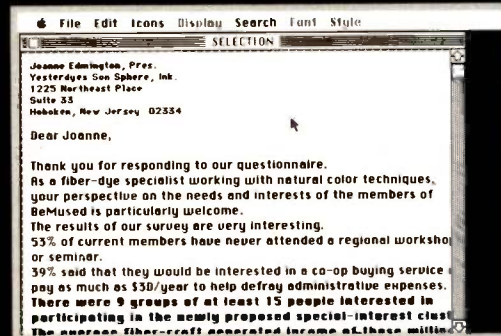

Built-in text formatting lets you combine information in a new way for mail merge letters, memo's, reports or free-form comments.

Helix provides a unique place to work because it takes a different approach.

It is based on the idea that we discover the important questions, relationships, and connections between things by working with them.

(So we need to be able to work with words and numbers in many different forms).

That our own experience, perception, and understanding are the basis of true "knowledge work".

And that this process can be both productive and playful, intently serious and intensely enjoyable.

(So we need a technology that is flexible, accommodating, and directly responsive to our actions and style of dialogue).

Inquiry 287

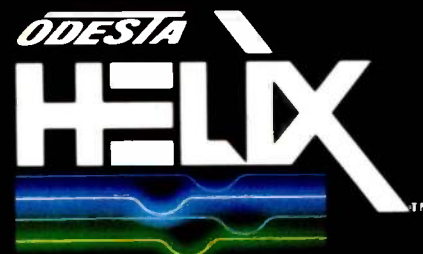

A Data-Based Information Management & Decision Support System



# ANNOUNCING ANOTHER KING-SIZE ADVANTAGE C.ITOH HAS OVER OTHER PRINTERS!

The biggest name in printers might be a name you don't even know. C. Itoh.

But people who do know C. Itoh printers know that they've always had a big edge in speed. And an edge in reliability.

And an edge in support, with service centers nationwide and the backing of a worldwide \$60 billion parent company.

And now, C. Itoh ProWriter™ dot matrix and StarWriter™ daisy wheel printers have a big edge in price, too.

We've been able to reduce our retail prices an average of 30%, because we've reduced our distribution costs by selling directly to our dealers.

It's given us a price advantage of \$80 to \$1,000 over what the competition has to offer.

Take a look.

DOT MATRIX	BRAND	MODEL NO.	SPEED LINES PER MINUTE	PRICE MFG. SUGG. RETAIL
	C. ITOH	7500	54	\$ 289
EPSON	RX-80FT	44	369	
STAR	GEMINI 10X	48	399	
IBM	5152	36	494	

DAISY WHEEL			CHARACTERS PER SECOND	
	C. ITOH	A10-20S	29	\$ 669
QUME	LP20	20	799	
NEC	2010	20	950	
DIABLO	620	20	995	
C. ITOH	F10-55	58	1,449	
DATA PRODUCTS	DP55	55	1,895	
QUME	1155	55	1,995	
NEC	7700	55	2,495	

C. Itoh. The best selling printers in the world, with 1.7 million printers sold in 1984 alone, now have the best prices, too.

For more information call toll-free 1-800-423-0300. Or write C. Itoh Digital Products, Inc. 19750 South Vermont Avenue, Suite 220, Torrance, CA 90502.

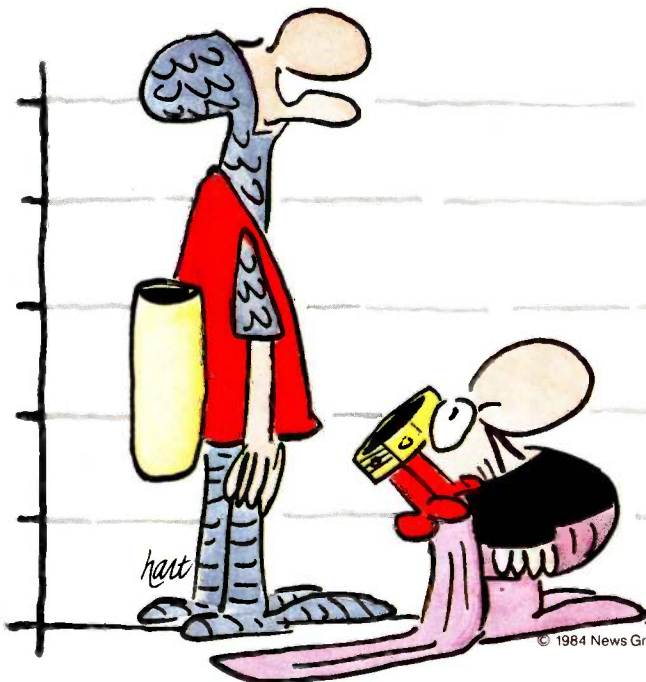

THEIR  
PRICES

OUR  
PRICES



ProWriter & StarWriter are Trademarks of C. Itoh Digital Products, Inc.  
© 1985 C. Itoh Digital Products, Inc.



## Thermal Printer Has Full Graphics Ability

**G**eneral Electric recently announced the Model 3-8100, a \$300 thermal-transfer letter-quality printer with full graphics capability. Although the printer comes standard with a Centronics-type parallel connector, GE will also sell two compatibility modules for \$89.95. One allows direct connection to the Atari 400/800 computers and Commodore's 64 and VIC-20; the other module permits direct connection to the IBM PCjr.

The Model 3-8100 prints at two speeds: 50 cps in draft mode and 25 cps in letter-quality mode. At both speeds, the printer is quiet. A 16-dot print head provides high-resolution dot-matrix output.

The Model 3-8100 can use single-sheet, roll, or 9½-inch-wide fanfold paper. It prints



The General Electric 3-8100 dot-matrix printer.

on thermal paper if you remove the cartridge. Each ribbon cartridge costs about \$6 and provides about 100,000 characters.

The manufacturer's suggested retail price for the

Model 3-8100 is \$299.95. Contact General Electric Co., Consumer Electronics Business Operation, POB 4840, Electronics Park, Syracuse, NY 13221, (315) 456-3304. Inquiry **600**.

## Keyboard Enhancement Has Macros, Data Encryption

**B**orland International's SuperKey is a RAM-resident keyboard-enhancement program featuring macros and automatic data encryption. This program lets you define, edit, save, load, and recall macros on your IBM PC in real time.

SuperKey has a memory-resident full-screen macro editor that can be pulled down on top of a currently running program. The program supports single-key macros, user-definable macro titles, help menus, date/time information, alternate arrow-key definition, key-click switching, keyboard lock/unlock, sound effects, and color control.

With SuperKey, you can recall from a command stack the last 20 commands entered. These are displayed in a menu window that lets you select, edit, and reuse the commands at the DOS command level or in a program. SuperKey has a cut-and-paste capability that permits any data to be copied from the screen, stored within SuperKey under any key, and then moved into another application.

The SuperKey data-encryption function lets you encode files in two modes. In the first mode, no second file is created, thus saving disk space. In the second

mode, you can encrypt binary files by transforming them into ASCII. This lets you transmit these files over telephone lines. The recipient of the files decrypts them using a special "key."

Also featured is a display burn-in protection capability that automatically switches off a monitor's video signal when no activity is detected for a reasonable length of time. The display is automatically reactivated when any key is pressed. The program is priced at \$69.95. Contact Borland International, 4113 Scotts Valley Dr., Scotts Valley, CA 95066, (408) 438-8400. Inquiry **601**.

## GE TVs Also Serve As Monitors; Modem Unveiled

**T**wo new television sets from General Electric can also serve as your computer monitor. The Model 13BC5509 is a 13-inch color monitor, and the Model 12XR5204 is a 12-inch black-and-white monitor.

Both units handle 80-character-per-line displays and feature a display width-reduction capability that prevents character loss at the screen's edge. They accept composite-video input as well as standard antenna connectors and are compatible with most home computers from Apple, Atari, Commodore, IBM, and other manufacturers.

Suggested retail price is \$489.95 for the color monitor and \$129.95 for the black-and-white unit.

In a concurrent announcement, GE introduced the Model 3-8200 direct/acoustic modem. This 300-bps modem has a standard RS-232C cable, and optional cables are available for direct connection to Atari or Commodore computers.

The 3-8200 has automatically switchable answer/originate modes and once tied into a database, it automatically adjusts for full- and half-duplex operation.

The Model 3-8200 modem has a suggested retail price of \$119.95. Contact General Electric Co., Consumer Electronics Business Operation, POB 4840, Electronics Park, Syracuse, NY 13221, (315) 456-3304. Inquiry **602**.

(continued)



### Kaypro's 286i Is an IBM PC AT Compatible

Kaypro's 286i, scheduled for formal introduction last month, is compatible with IBM's Personal Computer AT. It features a 6-MHz 80286 processor, two parallel ports, one serial port, and two 1.2-megabyte 5¼-inch floppy-disk drives. The system's main board comes with 512K bytes of

RAM, expandable to 640K bytes; expansion cards can supply an additional 15 megabytes of RAM to the system.

Three of the system's eight IBM-compatible expansion slots are occupied, leaving five for additional peripherals or memory. The 286i's 84-key keyboard is also

functionally compatible with the PC AT's.

Standard with the system are color graphics (RGB and composite, both of which are compatible with the IBM graphics-display card) and a clock/calendar with battery backup. Software bundled with the system includes Micropro's WordStar, Mail-

Merge, InfoStar, CalcStar, tutorials, and Microsoft's GW-BASIC interpreter.

The Kaypro 286i has a suggested list price of \$4550. For more information, contact Kaypro Corp., 533 Stevens Ave., Solano Beach, CA 92075. (619) 481-4300. Inquiry 603.

### 130-cps Printer Is Compatible with Epson RX-80

The Aero from Alphacom is a 130-cps dot-matrix printer that's compatible with existing software and graphics supporting Epson's RX-80 series printing protocols. Alphacom has optimized the Aero's print speed with the inclusion of path-seeking logic and a 2K-

byte buffer.

Aero produces the standard 96-member ASCII character set, and it lets you define up to 96 characters for custom applications. It forms 6- by 8-dot characters with true descenders in a 6- by 9-dot matrix grid using a 9-wire print head. The print

head outputs either 480 or 960 dots per line in either alphanumeric or bit-image modes.

Manuscripts printed out on the Aero can display any mixture of superscripts, subscripts, double-strike, enlarged and emphasized type, underlining, text, and graphics on the same line. Aero will print out an original and three copies using perforated or regular-bond paper.

Indicators for power-on, on-line, paper-out, and ready are located on the top right side of the Aero along with its operator controls. Aero comes with a self-test feature, and it uses standard Epson ink cartridges.

RS-232C and Centronics-type parallel versions of Aero are available. The suggested retail is \$249.95. Contact Alphacom Inc., 2323 South Bascom Ave., Campbell, CA 95008, (408) 559-8000. Inquiry 604.

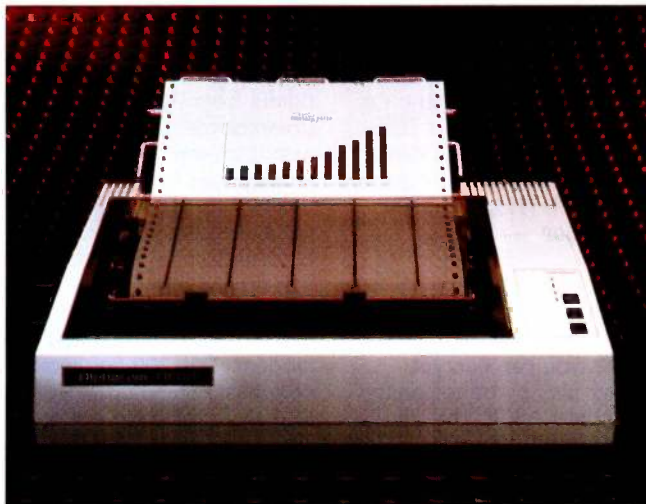

Alphacom's Aero is compatible with Epson's RX-80.

### ALL Card Allows 4 Megabytes RAM in IBM PC

ALL Computers' ALL Card AT1 features a custom CMOS memory-management unit (MMU) processor, in addition to other memory and interface enhancements, on a single IBM PC expansion card. The AT1 comes with a clock/

calendar, a serial port, the MMU, and room for 1 megabyte of on-board memory using 256K-byte chips. You can add up to a total of 4 megabytes to the system.

With 256K bytes of memory, the AT1 ALL Card

is \$1295. Without the MMU, it's \$795. A version with neither memory nor the MMU is \$395. Contact ALL Computers Inc., Suite 501, 110 Bloor St. W, Toronto, Ontario M5S 2W7, Canada, (416) 960-0111. Inquiry 605.

### Internal Hard Disk for PC AT

Control Data Corporation is now shipping a 30-megabyte hard-disk drive that fits inside IBM's PC AT. Called the StorageMaster 630, this drive has a typical access time of 30 milliseconds, which is reported to be approximately 25 percent faster than the native IBM drive.

The StorageMaster 630 uses the PC AT's resident disk controller and is shipped with adaptive software that lets you tweak it for operation with PC-DOS 3.0. The software gives you the ability to logically partition and format the disk, and includes diagnostic routines.

A pair of StorageMaster 630s can be tucked side-by-side within the PC AT's cabinet. Installing the StorageMaster 630 into the PC AT housing is said to require less than one hour.

Disk image or selected file-backup capabilities for the StorageMaster 630 are available through use of Control Data's 45-megabyte StorageMaster 745 ¼-inch cartridge streaming-tape backup system.

The suggested list price for the StorageMaster 630 is \$2145. Contact Control Data Corp., 8100 34th Ave. S, POB 0, Minneapolis, MN 55440, (800) 328-3390. Inquiry 613.

(continued)



# They said it couldn't be done. Borland Did It. Turbo Pascal 3.0

## The industry standard

With more than 250,000 users worldwide Turbo Pascal is the industry's de facto standard. Turbo Pascal is praised by more engineers, hobbyists, students and professional programmers than any other development environment in the history of microcomputing. And yet, Turbo Pascal is simple and fun to use!

COMPILATION SPEED
EXECUTION SPEED
CODE SIZE
BUILT-IN INTERACTIVE EDITOR
ONE STEP COMPILE (NO LINKING NECESSARY)
COMPILER SIZE
TURTLE GRAPHICS
BCD OPTION
PRICE

TURBO 3.0	TURBO 2.0	MS PASCAL
8 sec.	16 sec.	206 sec.
9 sec.	13 sec.	20 sec.
12 K	12 K	35 K
YES	YES	NO
YES	YES	NO
YES	35K	300K+
35K	NO	NO
YES	NO	NO
YES	NO	\$295 <sup>00</sup>
YES	\$54 <sup>95</sup>	
\$69 <sup>95</sup>		

## The best just got better: Introducing Turbo Pascal 3.0

We just added a whole range of exciting new features to Turbo Pascal:

- First, the world's fastest Pascal compiler just got faster. Turbo Pascal 3.0 compiles twice as fast as Turbo Pascal 2.0! No kidding.
- Then, we totally rewrote the file I/O system, and we also now support I/O redirection.
- For the IBM PC versions, we've even added "turtle graphics" and full tree directory support.
- For all 16 Bit versions, we now offer two additional options: 8087 math coprocessor support for intensive calculations and Binary Coded Decimals (BCD) for business applications.
- And much much more.

### The Critics' Choice.

**Jeff Duntemann, PC Magazine:** "Language deal of the century . . . Turbo Pascal: It introduces a new programming environment and runs like magic."

**Dave Garland, Popular Computing:** "Most Pascal compilers barely fit on a disk, but Turbo Pascal packs an editor, compiler, linker, and run-time library into just 29K bytes of random-access memory."

**Jerry Pournelle, BYTE:** "What I think the computer industry is headed for: well documented, standard, plenty of good features, and a reasonable price."

## Portability

Turbo Pascal is available today for most computers running PC DOS, MS DOS, CP/M 80 or CP/M 86. A XENIX version of Turbo Pascal will soon be announced, and before the end of the year, Turbo Pascal will be running on most 68000 based microcomputers.

## An Offer You Can't Refuse

Until June 1st, 1985, you can get Turbo Pascal 3.0 for only \$69.95. Turbo Pascal 3.0, equipped with either the BCD or 8087 options, is available for an additional \$39.95 or Turbo Pascal 3.0 with both options for only \$124.95. As a matter of fact, if you own a 16 Bit computer and are serious about programming, you might as well get both options right away and save almost \$25.

## Update policy

As always, our first commitment is to our customers. You built Borland and we will always honor your support.

So, to make your upgrade to the exciting new version of Turbo Pascal 3.0 easy, we will accept your original Turbo Pascal disk (in a bend-proof container) for a trade-in credit of \$39.95 and your Turbo87 original disk for \$59.95. This trade-in credit may only be applied toward the purchase of Turbo Pascal 3.0 and its additional BCD and 8087 options (trade-in offer is only valid directly through Borland and until June 1st, 1985).

(\* Benchmark run on an IBM PC using MS Pascal version 3.2 and the DOS linker version 2.6. The 179 line program used is the "Gauss-Seidel" program out of Alan R. Miller's book: *Pascal programs for scientists and engineers* (Sybex, page 128) with a 3 dimensional non-singular matrix and a relaxation coefficient of 1.0.

TURBO PASCAL

NOT COPY-PROTECTED

Available at better dealers nationwide. Call (800) 556-2283 for the dealer nearest you. To order by Credit Card call (800) 255-8008, CA (800) 742-1133

YES! I want the Best! Quantity

Please send:

Pascal 3.0	\$ 69.95	_____
Pascal w/8087	\$109.90	_____
Pascal w/BCD	\$109.90	_____
Pascal w/8087 & BCD	\$124.95 (SAVE \$24.90)	_____

\*These prices include shipping to all U.S. cities. All foreign orders add \$10 per product ordered.

Trade-in Credit Claimed: \_\_\_\_\_

Amount: (CA 6% tax) \_\_\_\_\_

Payment: VISA MC BankDraft Check

Credit Card Expir. Date: \_\_\_\_\_

Name on Card: \_\_\_\_\_

Card #: \_\_\_\_\_

For update: original Turbo disk must accompany order

Carefully Describe your Computer System!

Mine is: \_\_\_ 8 bit \_\_\_ 16 bit \_\_\_ MS-DOS \_\_\_ CP/M 86  
I Use: \_\_\_ PC-DOS \_\_\_ CP/M 80 \_\_\_ CP/M 86

My computer's name/model is: \_\_\_\_\_

The disk size I use is:  
 5 1/4"  8"  3 1/2"

Name: \_\_\_\_\_

Shipping Address: \_\_\_\_\_

City: \_\_\_\_\_ Zip: \_\_\_\_\_

State: \_\_\_\_\_ Telephone: \_\_\_\_\_ 15

CPD's and Purchase Orders WILL NOT be accepted by Borland. California residents: add 6% sales tax. Outside USA: add \$10 and make payment by bank draft, payable in US dollars drawn on a US bank.

**BORLAND**  
INTERNATIONAL

Software's Newest Direction  
4113 Scotts Valley Drive  
Scotts Valley, California 95066  
TELEX 172373

Inquiry 47

Turbo Pascal is a registered trademark of Borland International, Inc.



### S-100 Graphics Cards Produce TV-Quality Images

The S-Series of color-graphics products lets you produce images to the maximum resolution of NTSC and PAL television standards on Cromemco's 68000-based S-100 computer systems. The S-Series comprises the previously announced SDD Color Digitizer Interface, plus four new S-100 (IEEE-696 standard) bus cards.

The SVID Color Video Generator Board works with the SDMA Video Memory Controller card to generate color images by panning over a virtual 1024- by 1024-pixel image. The NTSC version displays 756 by 484 pixels, while the PAL card set generates a 756- by 577-pixel image. Depending on graphics memory, up to 8 bits of data can be allocated per pixel to select up to 256 colors from a palette of 256,000.

The 256KTP card comes

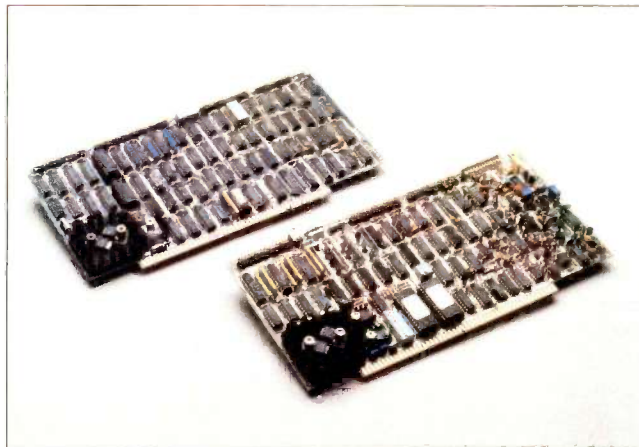

S-Series color-graphics cards from Cromemco.

with 256K bytes of two-ported memory; four 256KTP cards are required to take advantage of the full 1024- by 1024-pixel, 256-color capability of the S-Series. The SDCM Color Modulator Board converts red-green-blue signals to broadcast-type composite

signals meeting either the NTSC or PAL standards.

The S-Series cards allow computer-generated or digitized graphics to be overlaid on other broadcast images. A zoom feature allows up to 4-to-1 enlargement of screen areas, while a pan feature can be used

to move through the 1024 by 1024 image area either displaying edges or wrapping around to the opposite side of the image. Image input and output are possible using a wide range of devices: Any composite-video image can be digitized by the SDD card, while the other cards combine to provide output in RGB and NTSC and PAL composite-video formats.

The SVID video-generator board costs \$795, while the SDCM modulator card is \$995. Both are available in either NTSC or PAL versions. The SDMA controller board is \$795, and each 256KTP memory card is \$1995. The SDD digitizer card, for either NTSC or PAL versions, is priced at \$995. Contact Cromemco Inc., 280 Bernardo Ave., POB 7400, Mountain View, CA 94039, (415) 964-7400. Inquiry 606.

### TI's Arborist, Decision-Tree Analysis Software, Supports IBM

Texas Instruments' Arborist, a decision-tree analysis software package, runs on both the TI Professional Computer and IBM's Personal Computer. Arborist brings quantitative decision-making techniques to planners using these desktop computers.

In decision-tree analysis, a series of multiple chance events and possible decisions is represented by a tree structure. If the planner can estimate the outcome and probability of each individual decision or event, Arborist can then determine the best choice at each decision point.

Arborist is intended primarily for people who have at least a basic understanding of decision-tree analysis. It uses a graphical display of deci-

sion-tree structures to aid in the decision-making process. The program accommodates color or monochrome displays and the 8087 numeric coprocessor.

Arborist sells for \$595. For further details, contact Texas Instruments Inc., POB 80963, Dallas, TX 75380-9063, (800) 527-3500. Inquiry 607.

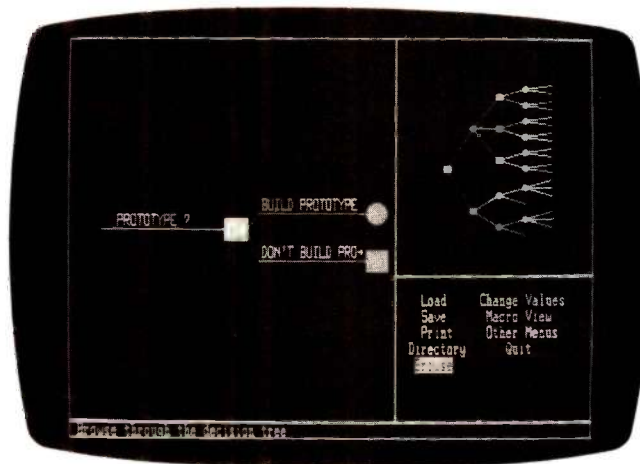

A decision tree created by TI's Arborist.

### XL/Serve for Macs

XL/Serve permits the Macintosh/XL (formerly the Lisa 2/10) to function as a disk and print server in an AppleTalk Personal Network. It lets distributed Macintoshes share disk storage and Imagewriter printers.

XL/Serve includes disk and printer software that runs concurrently on a host Macintosh/XL under MacWorks, driver software for individual Macintoshes, and a backup and restore utility.

You can partition the host disk into individual volumes, and users can be granted read-only or read-write status.

XL/Serve is \$200. Contact Infosphere Inc., 4730 Southwest Macadam Ave., Portland, OR 97201, (503) 226-3515. Inquiry 608.

(continued)



# Borland Does It Again: SuperKey \$69.95

Sure, ProKey™ is a nice little program. But when the people who brought you Turbo Pascal and SideKick get serious about keyboard enhancers, you can expect the impossible . . . and we deliver.

SuperKey	ProKey
ALL FEATURES RESIDENT IN RAM AT ALL TIMES	NO
RESIDENT PULL-DOWN MACRO EDITOR	NO
RESIDENT FILE ENCRYPTION	YES
PROKEY COMPATIBILITY	NO
DISPLAY PROTECTION	NO
ABILITY TO IMPORT DATA FROM SCREEN	NO
PULL-DOWN MENU USER INTERFACE	NO
CONTEXT-SENSITIVE ON-LINE HELP SYSTEM	NO
DISPLAY-ONLY MACRO CREATION	NO
ENTRY AND FORMAT CONTROL IN DATA FIELDS	NO
COMMAND KEYS REDEFINABLE "ON THE FLY"	NO
PRICE	129 <sup>95</sup>

**Total ProKey compatibility.** Every ProKey Macro file may be used by SuperKey *without change* so that you may capitalize on all the precious time you've invested.

**Now your PC can keep a secret!** SuperKey includes a resident file encryption system that uses your password to encrypt and decrypt files, even while running other programs. Two different encryption modes are offered:

**1. Direct overwrite encryption** (which leaves the file size unchanged) for complete protection. At no point is a second file that could be reconstructed by an intruder generated. Without your secret password, no one will ever be able to type out your confidential letters again!

**2. COM or EXE file encryption** which allows you to encrypt a binary file into an ASCII file, transmit it through a phone line as a text file and turn it back again into an executable file on the target machine (only of course if your correspondent knows the secret password!). Now, you will even be able to secretly exchange programs through Public Bulletin Board Systems or services such as CompuServe.

**Totally memory resident at all times,** gives SuperKey the ability to create, edit, save and even recall new or existing macro files anytime, even while running another program.

**Pull down macro editor.** Finally, a sensible way to create, edit, change and alter existing macro definitions. Even while using another application, a simple keystroke instantly opens a wordprocessor-like window where you're allowed to see, edit, delete, save and even attach names to an individual macro or file of macros, and much more.

## Sorry ProKey !

### Superb software at reasonable prices!

There is much more to SuperKey. Maybe the best reason to buy SuperKey is that it is a Borland International Product. Each one of our products is the best in its category. We only believe in absolutely superb software at reasonable prices!

### An offer you can't refuse.

Whether you are a ProKey user or you've never used a keyboard enhancer before, your boat has come in: until June 1st 1985 you can get your copy of SuperKey at this special introductory price.

### Get your PC a SuperKey today!

SuperKey is available now for your IBM PC, XT, AT, jr. and truly compatible microcomputers.



**Software's Newest Direction**  
4113 Scotts Valley Drive  
Scotts Valley, California 95066  
TELEX 172373

Inquiry 48

IBM is a registered trademark of International Business Machine Corporation. ProKey is a trademark of RoseSoft. SuperKey and SideKick are trademarks of Borland International, Inc.

SuperKey

NOT COPY-PROTECTED

Available at better dealers nationwide. Call (800) 556-2283 for the dealer nearest you. To order by Credit Card call (800) 255-8008, CA (800) 742-1133

Introductory Offer  
\$69.95\*

\*Introductory Offer valid until:  
June 1st, 1985

YES! Please rush SuperKey to me  
Send me \_\_\_\_\_ copies

Amount: (CA 6% tax) \_\_\_\_\_

Payment: VISA MC BankDraft Check

Credit Card Expir. Date: \_\_\_\_\_

Name: \_\_\_\_\_

Shipping Address: \_\_\_\_\_

Name on Card: \_\_\_\_\_

Card # \_\_\_\_\_

City: \_\_\_\_\_ Zip: \_\_\_\_\_

State: \_\_\_\_\_

Telephone: \_\_\_\_\_

K 15

COD's and Purchase Orders WILL NOT be accepted by Borland. California residents: add 6% sales tax. Outside USA: add \$10 and make payment by bank draft, payable in US dollars drawn on a US bank.

## Hayes Offers Smartcom II for the Macintosh

**H**ayes Microcomputer Products has announced Smartcom II for the Macintosh. The program, originally written for the IBM PC, has been redesigned to take advantage of the Macintosh graphical user interface.

Smartcom II is compatible with Hayes's existing stand-alone modems and with its recently introduced 2400-bps Smartmodem. Smartcom II can handle communications between computers in a hard-wired configuration at speeds of up to 19,200 bps.

Smartcom II has an "autopilot" feature that can be programmed to automatically perform such functions as logging onto remote systems, sending or receiving

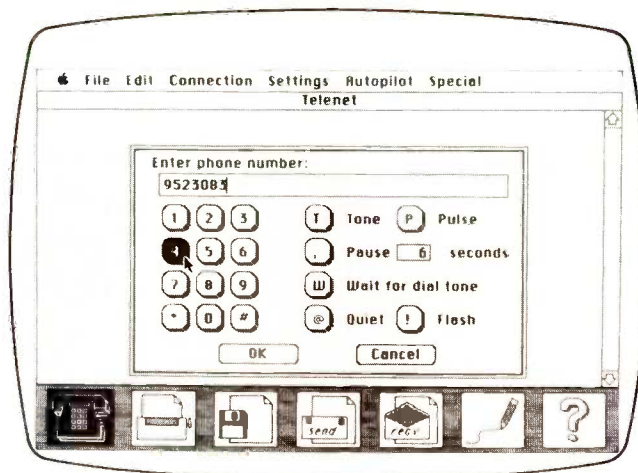

Smartcom II exploits the Mac's graphical user interface.

files, and performing database operations. It supports both the Hayes Verification

Protocol and the XMODEM protocol for file transfers. It also lets you switch back

and forth between voice and data during a communications session.

Hayes reports that the Smartcom II program will permit two Macintosh computers to exchange graphical images in real time using conventions similar to those in MacPaint. An image created on one screen is automatically reproduced on the remote screen. The second user can "take over" the drawing and make changes and additions.

The retail price for the Smartcom II software for the Macintosh is \$149. For more information, contact Hayes Microcomputer Products Inc., 5923 Peachtree Industrial Blvd., Norcross, GA 30092, (404) 449-8791. Inquiry **609**.

## Multuser Board for IBM Based on 68000

**T**he Multi-PC/68 from LinkData is a multiuser 68000 microprocessor board for the IBM Personal Computer. This two-board combination runs UNI-DOS, a DEC-like operating system that lets the PC run multiuser software written for the DEC PDP-11 family of minicomputers.

When equipped with Multi-PC/68, the IBM PC XT can support four terminals and run five concurrent programs written in the DIBOL or CADOL minicomputer languages. The IBM PC AT can support up to eight terminals and run nine programs. In addition, both the XT and AT can run MS-DOS

applications concurrently with UNI-DOS applications.

The dealer price of the Multi-PC/68 system, including UNI-DOS, ranges from \$2000 to \$4000, depending on how much memory and how many RS-232C ports are included. LinkData will also make available to dealers a \$200 DEC-like

word processor, a series of accounting packages (\$295 each), and a line of vertical-market applications packages with price tags spanning from \$750 to \$1000. For more information, contact LinkData, 2005 Route 22, Union, NJ 07083, (201) 964-6090. Inquiry **610**.

## Harmony Comes to Mac

**H**armony is a set of productivity tools that runs as a desk accessory on the 512K-byte Macintosh or as an application program on the 128K-byte Macintosh.

Harmony offers a full database in which each record can hold up to 18 information fields. Harmony has a time-manager module with a calendar, an appointment book with project-management features, a memo writer, and a print-spooler application that spools files from MacWrite and Micro-

soft Word.

Other features include a telecommunications application with auto-dial capabilities. Harmony can work in concert with Jazz from Lotus Development Corporation and other Macintosh programs. Intermatrix says that the program will be available in mid-April and that it will be priced at \$195. Contact Intermatrix, 5547 Satsuma Ave., North Hollywood, CA 91601, (818) 509-0474. Inquiry **611**.

## Harris Announces PC Network/File Server

**T**he Harris 9300 network/file server can link up to 16 IBM PC-compatibles, 3270 terminals, Harris PCs, or printers with a high-capacity hard-disk drive and a local-area network.

Devices are linked by a coaxial cable with a data-flow rate of 1 megabit per second. The 9300 uses an 80286 chip for network processing and supports up to 80 megabytes of hard-disk storage and 2 megabytes of memory. An optional Z80B runs word-processor and

office-automation programs developed by Lanier, a subsidiary of Harris.

The system with 1 megabyte of memory, 37 megabytes of hard-disk storage, and hardware for connection to the network is about \$11,000. Adapter cards for personal computers are \$1050 each. Deliveries are expected to begin in June. Contact Harris Corp., Melbourne, FL 32919, (305) 727-9100. Inquiry **612**.

(continued on page 440)



# Speed, Power, Price.

## Borland's Turbo Pascal Family.



**The industry standard.** With more than 250,000 users worldwide Turbo Pascal is the industry's de facto standard. Turbo Pascal is praised by more engineers, hobbyists, students and professional programmers than any other development environment in the history of microcomputing. And yet, Turbo Pascal is simple and fun to use!

**Jeff Duntemann, PC Magazine:** "Language deal of the century . . . Turbo Pascal: It introduces a new programming environment and runs like magic."

**Dave Garland, Popular Computing:** "Most Pascal compilers barely fit on a disk, but Turbo Pascal packs an editor, compiler, linker, and run-time library into just 29K bytes of random-access memory."

**Jerry Pournelle, BYTE:** "What I think the computer industry is headed for: well documented, standard, plenty of good features, and a reasonable price."

**Portability.** Turbo Pascal is available today for most computers running PC DOS, MS DOS, CP/M 80 or CP/M 86. A XENIX version of Turbo Pascal will soon be announced, and before the end of the year, Turbo Pascal will be running on most 68000 based microcomputers.

**\$69.95**

### High resolution monochrome graphics for the IBM PC and the Zenith 100 computers

**Dazzling graphics and painless windows.** The Turbo Graphix Toolbox will give even a beginning programmer the expert's edge. It's a complete library of Pascal procedures that include:

- Full graphics window management.
- Tools that will allow you to draw and hatch pie charts, bar charts, circles, rectangles and a full range of geometric shapes.
- Procedures that will save and restore graphic images to and from disk.
- Functions that will allow you to precisely plot curves.
- Tools that will allow you to create animation or solve those difficult curve fitting problems, and much, much more . . . . .

**No sweat and no royalties.** You may incorporate part, or all of these tools in your programs, and yet, we won't charge you any royalties. Best of all, these functions and procedures come complete with commented source code on disk ready to compile!



**\$54.95**  
**NEW**

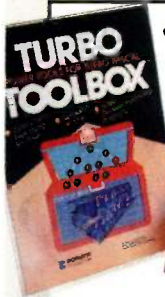

### Searching and sorting made simple

**The perfect complement to Turbo Pascal.** It contains: **Turbo-Access**, a powerful implementation of the state-of-the-art B+ tree ISAM technique; **Turbo-Sort**, a super efficient implementation of the fastest data sorting algorithm, "Quicksort on disk". And much more.

**Jerry Pournelle, BYTE:** "The tools include a B+ tree search and a sorting system; I've seen stuff like this, but not as well thought out, sell for hundreds of dollars."

**Get started right away: free database!** Included on every Toolbox disk is the source code to a working data base which demonstrates how powerful and easy to use the Turbo-Access system really is. Modify it to suit your individual needs or just compile it and run.

**Remember, no royalties!**

**\$54.95**

**From Start to Finish in 300 pages.** Turbo Tutor is for everyone, from novice to expert. Even if you've never programmed before, Turbo Tutor will get you started right away. If you already have some experience with Pascal or another programming language, Turbo Tutor will take you step by step through topics like data structures and pointers. If you're an expert, you'll love the sections detailing subjects such as "how to use assembly language routines with your Turbo Pascal programs."

**A must.** You'll find the source code for all the examples in the book on the accompanying disk ready to compile. Turbo Tutor might be the only reference on Pascal and programming you'll ever need.

**\$34.95**



## TURBO PASCAL FAMILY

Available at better dealers nationwide. Call (800) 556-2283 for the dealer nearest you. To order by Credit Card call (800) 255-8008, CA (800) 742-1133

Carefully Describe your Computer System!  
 Mine is:  8 bit  16 bit  
 I Use:  PC-DOS  MS-DOS  
 CP/M 80  CP/M 86  
 My computer's name/model is: \_\_\_\_\_

The disk size I use is:  
 5 1/4"  8"  3 1/2"

Name: \_\_\_\_\_

Shipping Address: \_\_\_\_\_

City: \_\_\_\_\_ Zip: \_\_\_\_\_

State: \_\_\_\_\_ Telephone: \_\_\_\_\_

Pascal 3.0 \$ 69.95  
 Pascal w/8087 \$109.90  
 Pascal w/BCD \$109.90  
 Pascal w/8087 & BCD \$124.95

Turbo Toolbox \$ 54.95  
 Turbo Graphics \$ 54.95  
 Turbo Tutor \$ 34.95

\*These prices include shipping to all U.S. cities. All foreign orders add \$10.

Amount: (CA 6% tax) \_\_\_\_\_

Payment: VISA MC BankDraft Check

Credit Card Expir. Date: \_\_\_\_\_

Name on Card: \_\_\_\_\_

Card #: \_\_\_\_\_

COD's and Purchase Orders WILL NOT be accepted by Borland. California residents: add 6% sales tax. Outside USA: add \$10 and make payment by bank draft, payable in US dollars drawn on a US bank.

**BORLAND INTERNATIONAL**

**Software's Newest Direction**  
 4113 Scotts Valley Drive  
 Scotts Valley, California 95066  
 TELEX: 172373

Inquiry 49

Turbo Pascal is a registered trademark of Borland International, Inc.



# Introducing PC software the right way to do

IBM's new Personal Decision Series. A powerful team of business programs designed for exceptional flexibility.

There's rarely one best way of doing anything.

Rather, lots of very good ways: a reality that IBM's Personal Decision Series handily accommodates.

More than any software we know of, it gives you choices. You tailor it to your

needs, instead of vice versa.

You begin with *Data Edition*, a program that not only manages huge amounts of information, but lets you take it from a surprising variety of sources: data banks, mainframes, even files created by other PC programs.

And you can retrieve your data in nearly any form you like, without a lot of headscratching. You can begin producing real work in a couple of hours.

Add *Reports+* and you can create

your own style documents, pulling facts from up to 6 *Data* files at a time, in formats you can design, for applications you can invent.

*Graphs* gives you a choice of 13 graph styles, with over 20 variations. And you can update old graphs without

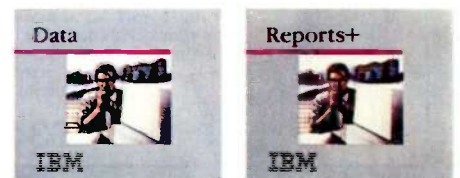

With IBM's new Personal Decision Series, you start with *Data Edition*, adding others, like *Reports+* or *Plans*, as you like.

For even more help, you can add *Appoint-*





# based on the curious notion that things is any way you want to.

having to make new ones.

There's also *Plans+* for financial modeling and spreadsheets, and *Words* for putting your sentences, numbers and graphs all together.

The Personal Decision Series can even take information from a number of

non-Series programs. So if you already have a favorite spreadsheet or writing program, you may still be able to use it.

You can even use files from an IBM System/36 or System/370 computer, by adding an *Attachment/36* or */370 Edition*.

All of which is perfect for people

who insist on doing things their way.

Do you know somebody like that?

To learn more, call an IBM marketing representative, or visit an IBM Product Center or authorized IBM PC dealer.

For the store nearest you, and a free brochure, call 800-447-4700. (In Alaska and Hawaii, 800-447-0890.)

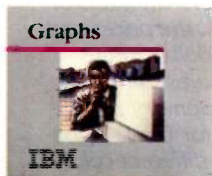

*ment Calendar, Client Time/Cost Accounting, and Prospect Tracking Editions.*

Also, the Personal Decision Series works with data from IBM's new *Business Management*

*Series*, a powerful family of accounting programs.

And ask about IBM Extended Support services, a way to get software updates and telephone assistance direct from IBM.

**IBM**

Personal Computer Software

## Conducted by Steve Ciarcia

### ELEMENTARY INFORMATION

Dear Steve,

Can you tell me where I can get specific and in-depth answers to elementary questions about computers and electronics? I know that you answer questions, but I also know that you couldn't be expected to give very lengthy answers to my beginner's questions.

CHARLES F. PORTER  
Cedar Rapids, IA

*The Ask BYTE column addresses hardware-related questions of general interest but is not meant for the beginner. BYTE's sister publication, Popular Computing, caters to a less technical audience, and its Ask Popular column addresses questions related to computers in general. Both publications may answer your specific question, but the turnaround time is lengthy.*

*If you need specific answers to specific questions in a reasonable amount of time, try a local computer club. There is usually an "expert" available on almost any topic. Failing that, the local bookstore will feature many books on computers and computer-related material.—Steve*

### S-100 SWITCHING SUPPLY

Dear Steve,

Will you be doing an article on a switching power supply for the S-100 bus?

I hear that switching supplies are less expensive to build than linear supplies; the selling prices I have seen are not less. Could Micromint offer a power-supply kit for this purpose?

ERNEST A. KNIPP  
Houston, TX

*A switching power supply for S-100-type computers is a good idea, and I will consider it for a future article.*

*The cost of switching-type power supplies is usually less than linear-regulated supplies of comparable power because smaller capacitors and inductors are used and can be packaged in a smaller volume. They also generate less heat and are easier to cool, resulting in a lower*

*overall installed cost.*

*If you want to build your own switching supply, my article in the November 1981 BYTE provides the basics. "Switching Power Supplies: An Introduction" covers the fundamentals of design and describes a workable unit. This article isn't a do-it-yourself S-100 power-supply project, but it should give you most of the basics.*

*Several  $\pm 12$ -V, 5-V switching supplies are available commercially, including the MPX-10 (from Micromint, 561 Willow Ave., Cedarhurst, NY 11516), which powers the MPX-16 computer. Others are available from Kepco Inc., 131-38 Sanford Ave., Flushing, NY 11352; Lambda Electronics, 515 Broad Hollow Rd., Melville, NY 11747; and Sorensen, 676 Island Pond Rd., Manchester, NH 03103.—Steve*

### GRAPHIC-ARTS COMPUTER

Dear Steve,

I would like to do graphic-arts work with a computer capable of producing a minimum of about 800 by 800 pixels and at least 100 simultaneously displayable colors. I have seen ads for various color boards or dedicated graphics computers, but they either don't match my specs or they are too expensive.

I'd like to build my own color add-on board for the Commodore 64 or a complete computer. I'd appreciate any suggestions.

LES KOHUTH  
Syosset, NY

*High-resolution graphics systems are expensive and seem overpriced in comparison to the graphics systems available on microcomputers. To understand this high cost, let's look at the components of a high-resolution graphics system.*

*To display the resolution that you mentioned, a monitor with a video bandwidth of at least 18 to 20 MHz is needed to distinguish individual pixels, or dots. This requirement can be understood if we look at the makeup of one scan line of the picture.*

*The normal scan rate is 15,750 scans per second, and at 800 pixels of hori-*

*zontal resolution, this is 12,600,000 pixels per second. However, the case where all the pixels are lit results in a zero-bandwidth requirement, and a DC voltage is all that is required. In the worst case, when every other pixel is lit, a clear display of 6 million pixels per second is needed. This appears to require only a 6-MHz bandwidth, but bandwidth is usually defined as the frequency where the signal (or gain) is reduced by 3 dB, or 50 percent of the normal level. Such a bandwidth would result in low brightness and contrast in picture areas where fine detail is shown. To display sharp images at this resolution, it is necessary to approximate a square wave at 6 MHz, and the first component of a square wave above the fundamental is the third harmonic, or 18 MHz. This is the minimum acceptable, and a noticeable improvement should be seen if the bandwidth is extended to the next component, which is the fifth harmonic (30 MHz).*

*The standard television sweep frequencies generate 525 horizontal lines per frame in two vertical scans (interlaced). A limit of about 400 lines within this region is required for good linearity. Most microcomputer graphics systems provide 200 or so lines by using the so-called noninterlace mode, displaying the same information on adjacent pairs of lines. This can be doubled by using twice as much memory and reprogramming the video controller. Getting to 800 lines requires twice as many horizontal sweeps per frame (and half the frame rate), which is not within the capabilities of the popular \$500 RGB monitors. Monitors of this type are available, but the prices are in the several-thousand-dollar range.*

*800 by 800 pixels requires 640K bits, or about 80K bytes, of memory to give one color (we get black for free). If you want to be able to assign different colors to each pixel, rather than define characters within a block of 8 by 8 contiguous pixels, the memory is arranged in layers. One 80K-byte layer gives black and white, two layers doubles this to four colors (three colors plus black), another layer doubles again, etc., for as many colors as we want, or can afford. Your spec of*

(continued)



*Four score and seven years ago our fathers brought forth, upon this continent, a new nation, conceived in liberty, and dedicated to the proposition that "all men are created equal."*

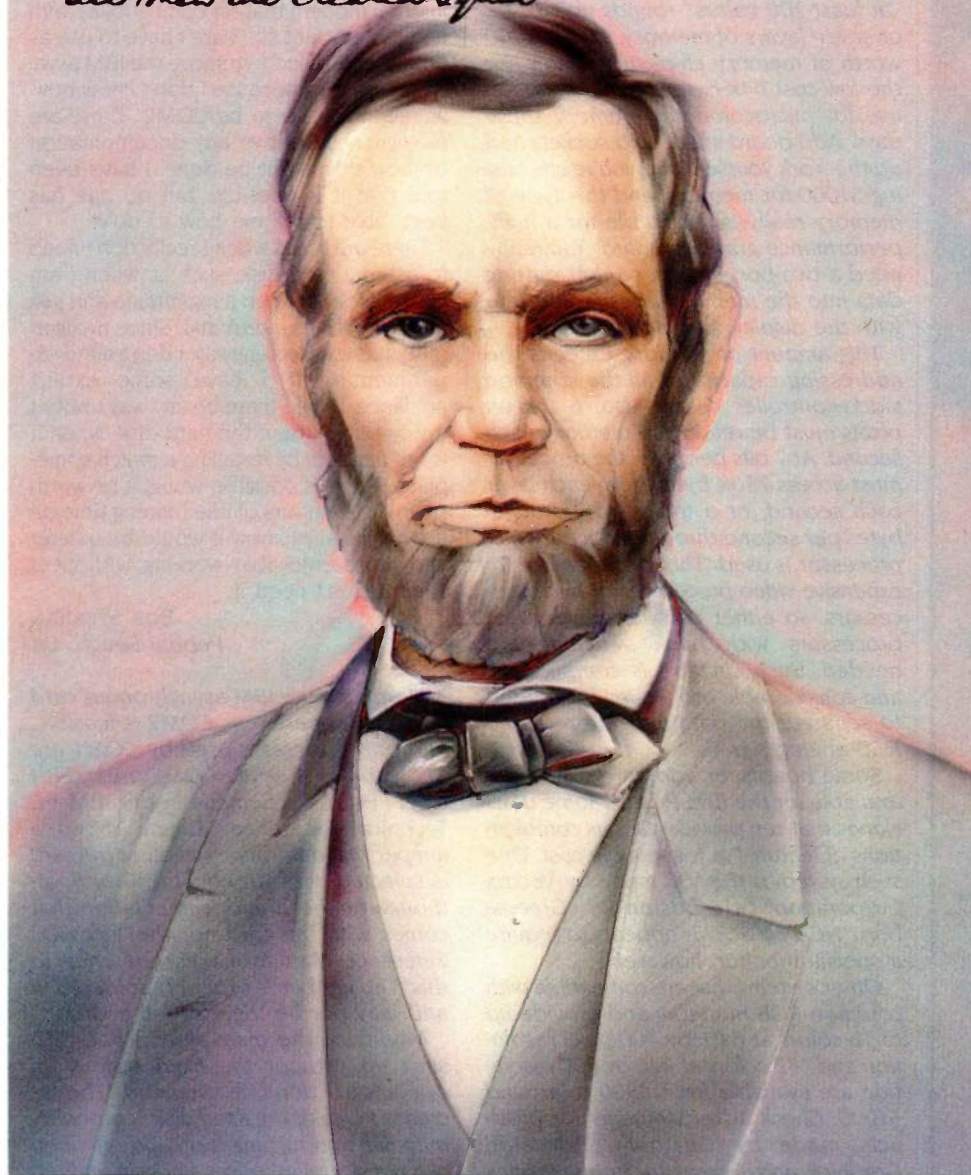

The picture in this ad is actually an 18" by 24" collector's item—an originally commissioned museum-quality print. This month, the Gettysburg print is yours, absolutely free, at most computer stores that carry Leading Edge Word Processing.

For the name of the dealer nearest you, give us a call.

800-343-6833,  
(617) 828-8150.



LEADING EDGE™

Leading Edge Products, Inc.  
Systems and Software Division  
225 Turnpike Street, Canton, MA 02021

## WORD PROCESSORS AT THE LEADING EDGE

Ah, the great ones . . .

They organized their ideas, their intuitions, their idioms. They set them down, sorted them out, arranged them and re-arranged them till they came out right.

They used small scraps of paper to record huge hunks of Truth; primitive tools to produce profound prose. But when the words finally went forth, they

made indelible marks on all who read them.

The amazing thing is that these monumental processors of words, did it without the benefit of monumental help.

Like Leading Edge Word Processing; the easiest to use, yet most potent piece of software ever created to take full advantage of all the power inherent, but until now un-tapped, in today's

most sophisticated personal computer. (Like the IBM® PC and the even faster and more powerful Leading Edge™ PC.)

The heart and soul of it is a 5 1/4" floppy disk, elegantly logical instruction manual and documentation . . . everything. And what you end up with is word processing at the leading edge.

### LEADING EDGE™ WORD PROCESSING FROM \$100

IBM IS A REGISTERED TRADEMARK OF INTERNATIONAL BUSINESS MACHINES CORPORATION  
LEADING EDGE IS A TRADEMARK OF LEADING EDGE PRODUCTS, INCORPORATED





# GPIB <sup>2</sup>

IEEE-488 Interfaces and Bus Extenders For:

**IBM PC, PCjr & COMPATIBLES**

**DEC UNIBUS, Q-BUS & RAINBOW 100**

**MULTIBUS, VMEbus STD & S-100**

Full IEEE-488 functionality, with the most comprehensive language and operating system coverage in the industry. It takes experience to make IEEE-488 systems work with nearly 4000 devices available from more than 500 different manufacturers, and experience is what enables National Instruments to take the GPIB to the second power and beyond.

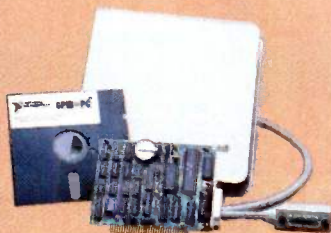

**2** Your personal guarantee of unsurpassed customer support and satisfaction. CALL 1-800-531-GPIB for instant access to 100+ man-years of GPIB experience.

**NATIONAL INSTRUMENTS**  
 12109 Technology Blvd.  
 Austin, TX 78727  
 1-800-531-5066 512/250-9119  
 Telex: 756737 NAT INST AUS

IBM and PCjr are trademarks of International Business Machines, MULTIBUS is a trademark of Intel, DEC, UNIBUS, Q-BUS, and Rainbow 100 are trademarks of Digital Equipment Corporation

## ASK BYTE

*"at least 100 colors" rounds up to 128, or seven layers of memory. This is \$700 worth of memory chips, if you can use the low-cost 64K-byte chips in common use for microcomputer memory these days. Add board space and sockets and do the work yourself, and you're still talking \$1000 for memory, and this type of memory really isn't suitable for a high-performance graphics board. You really need a two-port system so that putting data into the memory doesn't interfere with the display and vice versa.*

*This amount of memory exceeds the addressing capacity of all the common video-controller chips. Also, 6 million pixels must be read from memory each second. At 7 bits per pixel, the processor must access 750K bytes from each layer each second, or a total of 5.25 megabytes per second throughput if only one processor is used. This is too fast for inexpensive video processors, or microprocessors, so either parallel or very fast processors with bank switching are needed. Such circuitry is complicated, and considerable processing is required to separate the data into the required RGB analog signals.*

*Some boards, or add-on systems, are available for the IBM PC and some of its clones that can provide various combinations of features at reasonable cost. One such system is the VX, made by Vectrix Corporation, 1416 Boston Rd., Greensboro, NC 27407. This appears to require a special monitor, however.*

*Other systems that are compatible with common RGB monitors and provide up to 16 colors at 640-by-400-pixel resolution and 132 colors at 320 by 200 resolution are available from \$300 to around \$1000. Check advertisements for products made by Quadram, Princeton Graphics, and Tecmar Inc. in magazines like BYTE to find some that might represent a satisfactory compromise. Another good source for information on this subject is Electronic Imaging magazine.*  
 —Steve

internal modem that for compatibility with some important software I have to use as COM1. I have had to remove the IBM asynchronous card because I don't know how to reconfigure it to be COM2. There are no switches on it or any documentation on how this might be done. I have been told that it is possible, but no one has been able to tell me how to do it.

There are times when I really don't need to use my hard disk, such as when I am working for hours on a mainframe and just using my XT as a terminal. Since my warranty has expired anyway, I don't mind experimenting if I have some expert guidance. Would there be any way to boot my system without the hard disk, when it is not needed, by installing a switch somewhere? If this is possible, would it be worth saving a few hours of idle running time on the hard disk? I know it would be quieter and more enjoyable working without it when I don't need it.

BOB STEPHAN  
 Pebble Beach, CA

*Modifying the IBM asynchronous card to make it operate as COM2 is feasible. The port addresses used by COM1 are 3F8H to 3FFH, while COM2 uses 2F8H to 2FFH. The schematic in the IBM PC Technical Reference Manual shows a jumper that determines whether the card is selected with A8 equal to 0 or 1, although neither the documentation that comes with the card nor the Technical Reference Manual makes reference to this. The jumper is probably soldered in and may not be there on all boards.*

*Modifying the main system board to start up without the fixed disk is an operation I don't recommend. The increase in life of the fixed disk is probably minimal, and turning it on and off when you need it might offset any gain realized by not running it full time. I also suspect, based on my experience with IBM PCs, that the fan makes as much noise as the disk, so there is little to be gained.*—Steve

### RECONFIGURING THE PC XT

Dear Steve,

I have two questions that I would like to have answers for. They both relate to the IBM PC XT. After devouring your most interesting articles and answers in BYTE, I believe you can answer them.

The XT comes equipped with an asynchronous communications card configured as COM1. I have installed a Hayes

### READING LATCH OUTPUTS

Dear Steve,

I have a Sinclair 1000 that I'm trying to use in a security system. In my system, octal latches monitor infrared beams. When a beam is broken, my program addresses a latch at an address above RAM and uses a POKE to put a 1 in the latch to ring the bell. This works fine. The problem is when I try to check the octal latches

(continued)



# HOW TO CONTROL THE RISE AND FALL OF POWER.

Your small business computer can give you the power to raise your productivity. But first you have to control the power you give it. Because even the slightest dip or surge of electricity can result in a shocking surprise. An instant loss of important data or misinformation. Even worse, a total power line failure can create department devastation... a total system crash. You can't afford errors, delays and other problems. After all, you've invested in a computer to increase efficiency. But now there's a solution you can afford The Sola SPS. This economical, UL listed Standby Power System is designed to protect personal, micro and mini computers from AC line disturb-

ances and failures. Sola SPS provides clean, regulated AC power to your computer when your power line experiences irregular voltage. Line dips or line surges are immediately converted to proper voltage. When the AC line is present, the SPS filters power to eliminate electrical noise. And when the AC line fails, the SPS goes into full action, providing precise AC power to the load from its internal battery. So the only noise you'll hear is the sound of performance. There's no maintenance. No installation. No kidding. Just plug it in and turn it on. Why let your productivity rise and fall with your power? The solution is as simple as SPS. The standby system that Sola stands behind.



Write for free literature. 1717 Busse Hwy., Elk Grove Village, IL 60007 (312) 439-2800

Inquiry 356

- Multiple color, high-resolution raster & bit image Prism™ graphics.
- 200 cps data processing mode.
- 110 cps text quality mode.
- 35 cps letter quality mode.
- 10 ips graphics print speed.
- Serial and parallel interfaces.
- 5000-byte buffer.

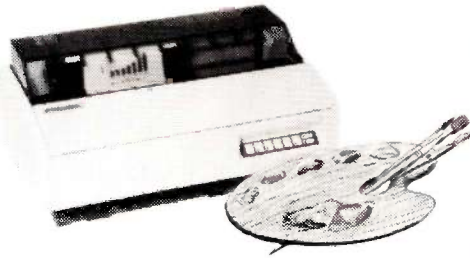

**Color your graphics with the Dataproducts 8050.  
For sale, lease or rent from MTI.**

The Dataproducts Model 8050 printer is one of the most economical yet highly versatile color printers available for use in today's professional microcomputer applications environment.

Whether you buy, rent or lease, MTI is the one source for all computer printers. And our prices are hard to beat. Call MTI and save.



A SUBSIDIARY OF DUCOMMUN INCORPORATED

**Computer & Data Communications Equipment  
Sales / Leasing / Service / Systems Integration**

Digital Equipment Corp., Intel, Texas Instruments, Hewlett-Packard\*Qume, Dataproducts, Diablo, Epson, Lear Siegler, Esprit, Wyse, Link, C. Itoh, PCI, Racal-Vadic, MICOM, Ven-Tel, Develcon, U.S. Design, Digital Engineering.

New York:	New Jersey:	Ohio:	Kentucky:
212/226-2337	518/449-5959	201/227-5552	216/464-6688
718/767-0677			502/426-1497
516/621-6200		Pennsylvania:	800/521-0167
		California:	412/931-9351
			513/891-7050
			818/883-7633

\*In MTI areas only.

All other areas: 800/645-6530

**ASK BYTE**

with the PEEK command, instead of seeing the latch, it reads garbage. I have tried addresses just above RAM all the way up to address 65535, and I still read garbage.

It appears that when you check an address that is above RAM it mirrors back to a RAM or ROM address. Can you tell me how I can address and see my octal latches instead of mirroring back to RAM? Thanks for your help.

DAN GROGAN  
San Pedro, CA

*It appears that your Sinclair 1000 is not reflecting your PEEK commands back into low memory. As I interpret your letter, you have a set of latches that are supposed to put data on the bus to tell the computer that a detector has been tripped, and you are having trouble reading the latch outputs.*

*Are you sure that the address decoder on the latch board is set to the address to which you are writing? Is it properly timed to put the data on the bus at the right time or hold it there long enough to be recognized by the processor? The fact that you can write a bit into the bell latch seems to indicate that you are able to address the high memory, but the timing in writing data into the latch could be a lot less critical than reading data.*

*Have you looked at the signals at the latch outputs and on the data bus to be sure that they are putting out the correct voltage levels? How about signal quality? The level is fairly easy to get with TTL or CMOS chips if the power-supply voltage is at the required 5 volts, but if the wiring connecting the latches to the computer bus isn't properly dressed, you can do horrible things to the normally clean square waves put out by the latches.*  
—Steve

**A/D FOR Z-100**

Dear Steve,

I have a Zenith Z-100 computer with two disk drives and with 192K bytes of memory. Now I am thinking of providing an A/D interface for the serial input so that I can feed in analog signals from various instruments, such as a spectrophotometer, pH meter, etc. Looking through the journals I located a few suppliers, though mostly of rather fancy multichannel data-acquisition units I do not need. At the most, I need four channels of input without any specialties attached. I would appreciate it if you could let me know of any

(continued)

**To get a lot  
out of your  
printer, you  
need a lot of  
programs,  
right?**

**Wrong.**  
Sure, you could buy one package to change type sizes, another to create fonts, and still another to print sideways.

Or you could get one simple program to do it all!

**Printworks.™  
It's loaded.**



SoftStyle, Inc. 7192 Kalaniana'ole Hwy. Suite 205  
Honolulu, Hawaii 96825 Phone (800) 367-5600  
\$69.95 Enhances over 30 dot matrix printers, including  
Epson and Okidata IBM PC or compatible





# The Most Powerful C

for the IBM AT • MACINTOSH • MS DOS • CP/M-80 • ROM APPLICATIONS  
IBM PC/XT • APPLE II • CP/M-86 • TRSDOS • CROSS DEVELOPMENT

## Why Professionals Choose Aztec C

AZTEC C compilers generate fast, compact code. AZTEC C is a sophisticated development system with assemblers, debuggers, linkers, editors, utilities and extensive run time libraries. AZTEC C is documented in detail. AZTEC C is the most accurate and portable implementation of C for microcomputers. AZTEC C supports specialized professional needs such as cross development and ROM code development. MANX provides qualified technical support.

### AZTEC C86/PRO

#### — for the IBM AT and PC/XT

AZTEC C86/PRO provides the power, portability, and professional features you need to develop sophisticated software for PC DOS, MS DOS AND CP/M-86 based microsystems. The system also supports the generation of ROM based software for 8088/8086, 80186, and 80286 processors. Options exist to cross develop ROM code for 65xx, 8080, 8085, and Z80 processors. Cross development systems are also available that target most micro computers. Call for information on AZTEC C86/PRO support for XENIX and TOPVIEW.

**POWERFUL** — AZTEC C86/PRO 3.2 outperforms Lattice 2.1 on the DHRYSTONE benchmark 2 to 1 for speed (17.8 secs vs 37.1) while using 65% less memory (5.8k vs 14k). The AZTEC C86/PRO system also compiles in 10% to 60% less time and supports fast, high volume I/O.

**PORTABLE** — MANX Software Systems provides real portability with a family of compatible AZTEC C software development systems for PC DOS, MS DOS, CP/M-86, Macintosh, CP/M-80, APPLE II+, IIe, and IIc (NIBBLE - 4 apple rating), TRSDOS (80-MICRO - 5 star rating), and Commodore C64 (the C64 system is only available as a cross compiler - call for details). AZTEC C86/PRO is compatible with UNIX and XENIX.

**PROFESSIONAL** — For professional features AZTEC C86/PRO is unparalleled.

- Full C Compiler (8088/8086 - 80186 - 80286)
- Macro Assembler for 8088/8086/80186/80286
- Linkage Editor with ROM support and overlays
- Run Time Libraries - object libraries + source DOS 1.x; DOS 2.x; DOS 3.x; screen I/O; Graphics; UNIX I/O; STRING; simulated float; 8087 support; MATH; ROM; CP/M-86
- Selection of 8088/8086, 80186, or 80286 code generation to guarantee best choice for performance and compatibility

- Utility to convert AZTEC object code or libraries to Microsoft format. (Assembly + conversion takes less than half the time as Microsoft's MASM to produce MS object)
- Large memory models and sophisticated memory management
- Support products for graphics, DB, Screen, & ...
- ROMable code + ROM support + separate code and data + INTEL Hex Converter
- Symbolic Debugger & Other Utilities
- Full Screen Editor (like Vi)
- CROSS Compilers are available to APPLE II, Macintosh, CP/M-80, TRSDOS, COMMODORE C64, and ROM based 65xx, and 8080/8085/Z80
- Detailed Documentation

AZTEC C86/PRO-AT ..... \$500  
(configured for IBM AT - options for 8088/8086)

AZTEC C86/PRO-PC/XT ..... \$500  
(configured for IBM PC/XT - options for 80186/80286)

AZTEC C86/BAS includes C compiler (small model only), 8086 MACRO assembler, overlay linker, UNIX, MATH, SCREEN, and GRAPHICS libraries, debugger, and editor.

AZTEC C86/BAS ..... \$199  
 AZTEC C86/BAS (CP/M-86) ..... \$199  
 AZTEC C86/BAS (DOS + CP/M-86) ..... \$299  
 UPGRADE to AZTEC C86/PRO ..... \$310  
 C-TREE Database with source ..... \$399  
 C-TREE Database (object) ..... \$149

### CROSS COMPILERS

Cross Compilers for ROM, MS DOS, PC DOS, or CP/M-86 applications.

VAX -> 8086/80xxx cross ..... \$5000  
 PDP-11 -> 8086/80xxx cross ..... \$2000

Cross Compilers with PC DOS or CP/M-86 hosts are \$750 for the first target and \$500 for each additional target. Targets: 65xx; CP/M-80; C64; 8080/8085/Z80; Macintosh; TRSDOS; 8086/8088/80186/80286; APPLE II.

### AZTEC C68K

#### — for the Macintosh

For power, portability, and professional features AZTEC C68K-c is the finest C software development system available for the Macintosh.

The AZTEC C68K-c system includes a 68000 macro assembler, a linkage editor, a source editor, a mouse based editor, a SHELL development environment, a library of UNIX I/O and utility routines, full access and support of the Macintosh TOOLBOX routines, debugging aides, utilities, make, diff, grep, TTY simulator with upload & download (source supplied), a RAM disk (for 512K Mac), a resource maker, and a no royalty license agreement. Programming examples are included. (Over 600 pages of documentation).

AZTEC C68K-c requires a 128K Macintosh, and two disk drives (frugal developers can make do with one drive). AZTEC C68K supports the 512K Macintosh and hard disks.

AZTEC C68K-c (commercial system) ..... \$500  
 AZTEC C68K-p (personal system) ..... \$199  
 AZTEC C68K-p to AZTEC C68K-c upgrade ..... \$310

Mac C-tree database ..... \$149  
 Mac C-tree database with source ..... \$399  
 Lisa Kit (Pascal to AZTEC C68k object converter) .. \$ 99

### AZTEC C85

#### — for the APPLE II

"...The AZTEC C-system is one of the finest software packages I have seen..." NIBBLE review, July 1984.

The only commercial C development system available that runs native on the APPLE II+, IIc, and IIe, the AZTEC C65 development system includes a full floating point C compiler compatible with UNIX C and other MANX AZTEC C compilers, a 6502 relocating assembler, a linkage editor, a library utility, a SHELL development environment, a full screen editor, UNIX I/O and utility subroutines, simple graphics, and screen functions.

AZTEC C65 (Apple DOS 3.3) ..... \$199  
 AZTEC C65/PRO (Apple DOS + ProDos) ..... \$350  
 (call for availability)

### AZTEC C II/PRO

#### — for CP/M-80

The first member of the AZTEC C family was the CP/M-80 AZTEC C compiler. It is "the standard" compiler for development on CP/M-80. The system includes the AZTEC C II C compiler, an 8080 assembler, a linkage editor, an object librarian, a full library of UNIX I/O and utility routines, CP/M-80 run time routines, the SMALL library (creates modules less than 3K in size), the fast linker for reduced development times, the ROM library, RMAC and M80 support, library source, support for DRI's SID/ZSID symbolic debugger, and more.

AZTEC C II/PRO ..... \$349  
 AZTEC C II/BAS ..... \$199  
 C-TREE Database with source ..... \$399  
 C-TREE Database in AZTEC object form ..... \$149

### AZTEC C80

#### — for TRSDOS (Radio Shack Model III & 4)

"I've had a lot of experience with different C compilers, but the Aztec C80 Compiler and Professional Development System is the best I've seen." 80-Micro, December, 1984, John B. Harrell III

This system has most of the features of AZTEC C II for CP/M. It is perhaps the best software development system for the Radio Shack Model III and IV.

AZTEC C80 model 3 (no floating point) ..... \$149  
 AZTEC C80 model 4 (full) ..... \$199  
 AZTEC C80/PRO (full for model 3 and 4) ..... \$299

To order or for information call:

# 800-221-0440

(201) 530-7997 (NJ and outside U.S.A.). Or write: MANX SOFTWARE SYSTEMS, P.O. Box 55, Shrewsbury, N.J. 07701.



TRS 80 RADIO SHACK TRS DOS is a trademark of TANDY.  
APPLE DOS MACINTOSH is a trademark of APPLE.

For Technical Support  
(Bug Busters) call: 201-530-6557

SHIPPING INFORMATION - Standard U.S. shipment is UPS ground (no fee). In the U.S. one day shipment is \$20, two days is \$10. Canadian shipment is \$10. Two days shipment outside the U.S. is by courier and is freight collect.



# STOP DATA LOSS.

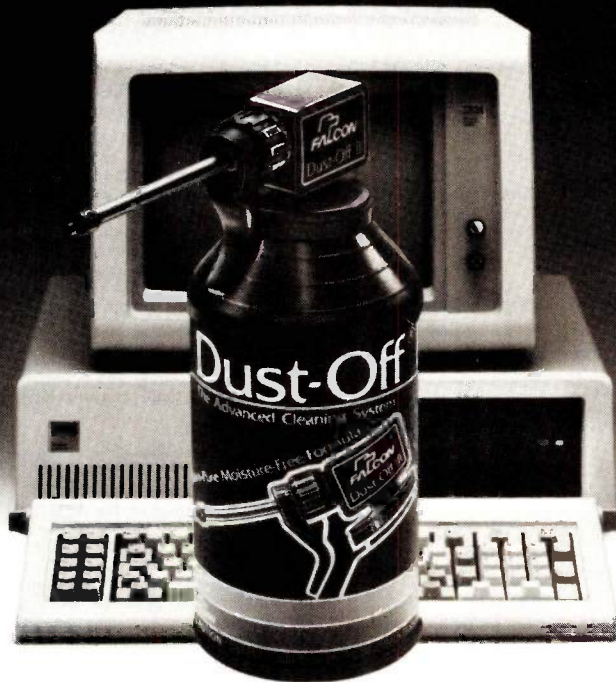

## CLEAN THE MACHINE!

There's enough to worry about without the headache of your computer's downtime or the loss of valuable data caused by dust.

Before dust affects your computer's operation do what a rapidly growing number of computer users do: use Dust-Off® II. Don't just move dust—remove



STAT-OFF II® neutralizes dust-holding static electricity from media and machines.

it. Unlike liquid cleaners, Dust-Off II is a safe, dry "canned air" cleaning system for your computers, printers, disk and tape drives, diskettes, CRTs, media storage containers and modems. In fact, it works on everything that works in the office.

Dust-Off II's patented valve gives you pinpoint fingertip-control to blast away pollutants before they cause aggravating downtime. Add the Stat-Off® II accessory, and you have the only dry, non-contact method for eliminating

dust-holding static electricity. The Dust-Off II system also includes the Dual Extender and the Mini-Vac vacuum for eliminating hard-to-reach dust.

Get Dust-Off II at your local computer or office supply dealer. Or send \$1.00 (postage and handling) for a 3 oz. trial size and literature.



**Dust-Off II**  
THE SAFE, DRY, "CANNED AIR" CLEANING SYSTEM.

## ASK BYTE

such units on the market.

HERBERT JONAS  
St. Paul, MN

Analog Devices (2 Technology Way, Norwood, MA 02062, (617) 329-4700) makes the  $\mu$ MAC-4000 series data-acquisition systems that provide up to 12 channels of 13-bit A/D input/output and serial communication, priced at \$995 and up.

Two other units that interface through RS-232C are the 16-channel, 12-bit ADC-1 from Remote Measurement Systems Inc., POB 15544, Seattle, WA 98115, (206) 525-3369. It's advertised at \$369. Also available is the BUSter D16 8-bit, 16-channel unit from Connecticut micro-Computer. The address is 36 Del Mar Dr., Brookfield, CT 06804, (203) 775-4595.

All three of the above units accept digital inputs as well as analog.

Since your Z-100 uses the S-100 bus, you might also want to consider the plug-in AIM-12 S-100 board from Dual Systems Corp., 2530 San Pablo Ave., Berkeley, CA 94702, (415) 549-3854. This unit provides for 16 channels of input with 12-bit conversion, priced at \$775.

—Steve ■

Between Circuit Cellar Feedback, personal questions, and Ask BYTE, I receive hundreds of letters each month. As you might have noticed, at the end of Ask BYTE I have listed my own paid staff. We answer many more letters than you see published, and it often takes a lot of research.

If you would like to share the knowledge you have on microcomputer hardware with other BYTE readers, joining the Circuit Cellar/Ask BYTE staff would give you the opportunity. We're looking for additional researchers to answer letters and gather Circuit Cellar project material.

If you're interested, let us hear from you. Send a short letter describing your areas of interest and qualifications to Steve Ciarcia, POB 582, Glastonbury, CT 06033.

IN ASK BYTE, Steve Ciarcia answers questions on any area of microcomputing. The most representative questions received each month will be answered and published. Do you have a nagging problem? Send your inquiry to

Ask BYTE  
c/o Steve Ciarcia  
POB 582  
Glastonbury, CT 06033

Due to the high volume of inquiries, personal replies cannot be given. All letters and photographs become the property of Steve Ciarcia and cannot be returned. Be sure to include "Ask BYTE" in the address.

The Ask BYTE staff includes manager Harv Weiner and researchers Bill Curlew, Larry Bregoli, Dick Sawyer, and Jeannette Dojan.



# Now Showing In Black And White

**i**f you own an IBM-PC or PC work-alike, Roland's new MB-142 monitor lets you show off your text and graphics in today's hottest colors—black and white. That's right! The MB-142 gives you black characters on a paper-white background—just like people have been reading for centuries. You can also have white characters on a black background with just the touch of a button.

Both of these black and white display formats are easier on the eyes and less fatiguing than the green or amber phosphor used in standard monochrome monitors. The MB-142's large 14-inch screen, combined with its ultra-high 720 x 350 resolution, can display characters that are larger and more legible than what you can get with ordinary monochrome monitors. Another great plus is that the MB-142 plugs directly into the monochrome board of your IBM or compatible—just like your present monochrome monitor, with nothing more to buy.

Because of the MB-142's advanced electronic circuitry, you even have the ability to mix graphics and text on the same display when using graphics and text boards from leading manufacturers such as Persyst, STB, Paradise, Hercules, AST and many others. What makes it all possible? The same sophisticated technology used in color monitors.

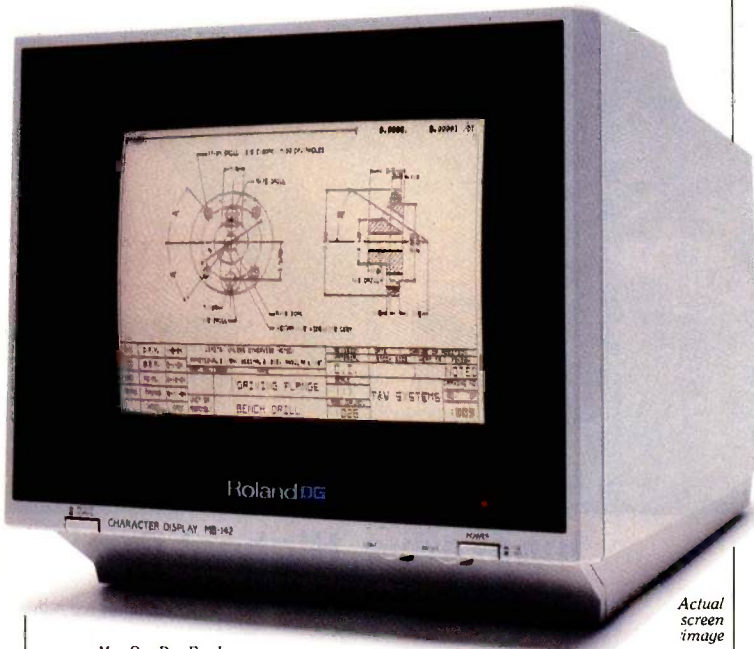

Actual screen image

M O D E L  
MB-142



**t**he MB-142 supports all the winning cards



**P**ush a button for instant reverse screen

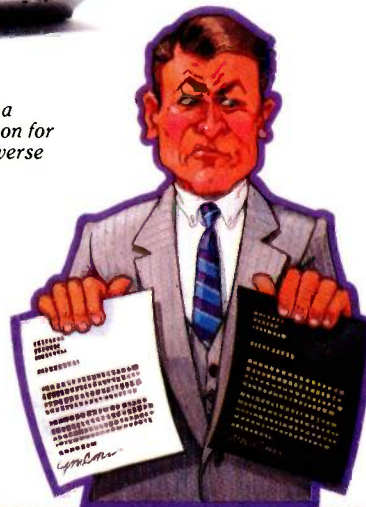

**f**or business, black and white makes more sense than green and black

**t**he big difference is that the MB-142 monitor does the job for significantly less money. The MB-142 is designed to interface economically, too. Imagine seeing your favorite business graphics or CAD/CAM packages, such as Lotus 1-2-3, Energraphics, Chart-Master, AutoCAD, CADDraft and VersaCAD, in ultra-high resolution black and white. Also, take full advantage of your program's windowing capability using the large 14-inch screen.

Take a good look at the differences that set the MB-142 apart from the rest. No other monochrome monitor gives you the fatigue-free black and white viewing, text and graphics capabilities and easy interface. Naturally enough, the MB-142 is from Roland DG—the new computer peripherals company that's pointing the way to the future. Look for this and other Roland products at fine computer dealers everywhere.

For more information, contact: Roland DG, 7200 Dominion Circle, Los Angeles, CA 90040. (213) 685-5141.

The software programs listed are trademarks of the following companies: AutoCAD, AUTODESK, Inc.; CADDraft, Personal CAD Systems, Inc.; Chart-Master, Decision Resources, Inc.; Energraphics, Enertronic Research, Inc.; Lotus 1-2-3, Lotus Development Corp.; VersaCAD, T&W Systems, Inc.

**Roland DG**



# EVEREX, EVER F

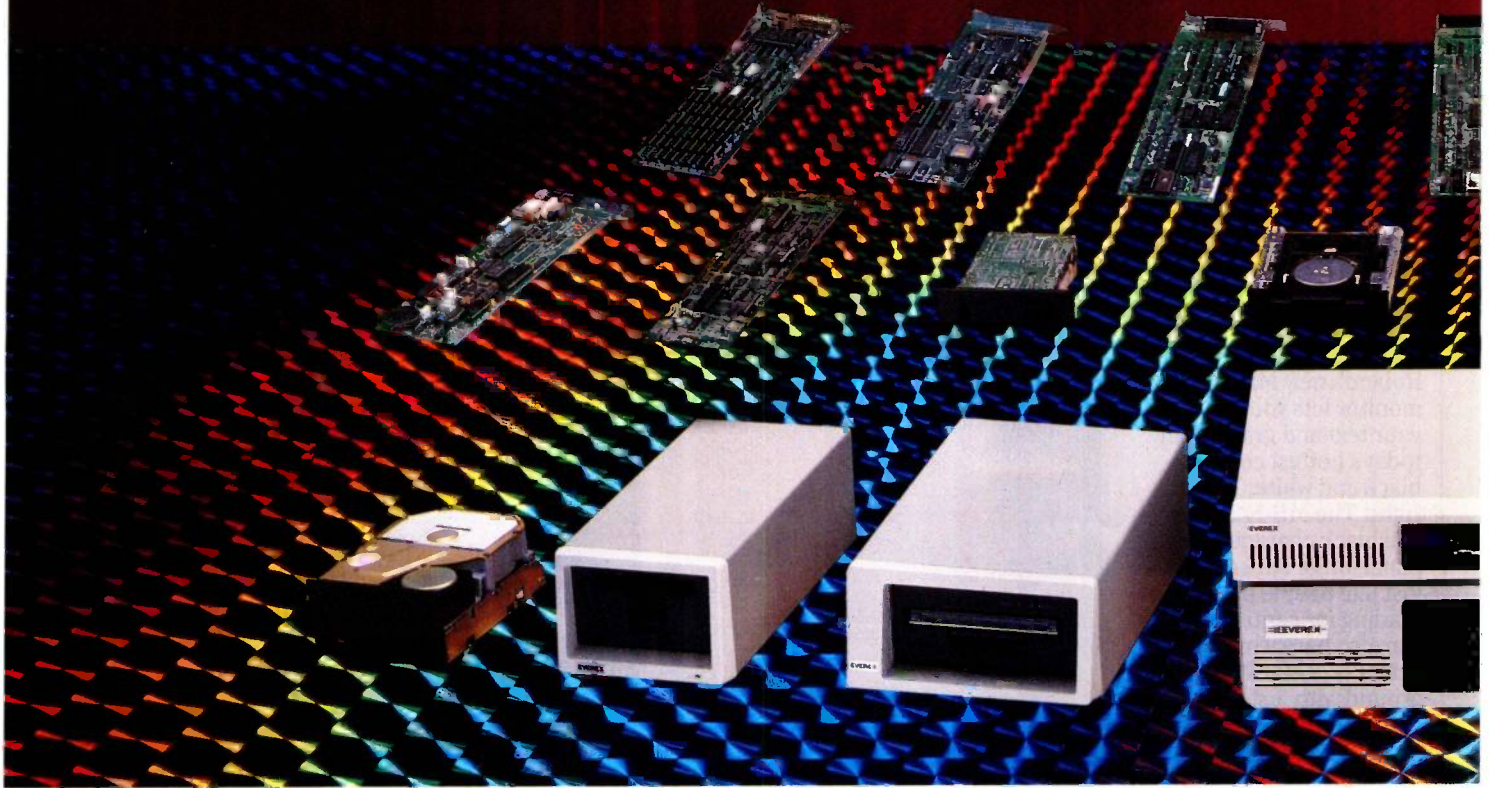

## Innovative, Highest Quality Products From

### BACKUP SYSTEMS

#### Internal

- Streaming Tape
- Cassette
- Floppy Tape

#### External

A selection of Streaming Tape, Cassette and Floppy Tape systems in either individual units or combined with hard disk drives and expansion slots.

#### Unique Features:

- Space-saving half-height internal systems
- Backup capacities up to 100 MB
- Fast image backup—ten megabytes backed up in minutes
- File-by-file and mirror image backup and restore
- EXCLUSIVE file-by-file restore from a fast mirror image backup
- Easy to use software, simply press a key—no complex commands
- Largest selection of backup/retrieve options

### EXPANSION SYSTEMS

#### Everex offers a complete line to choose from...

- Full-Size system with eight expansion slots and room to add up to four storage/backup systems.
- Half-Size system with three expansion slots and space for two storage/backup systems.
- Slimline system, only 2½-inches high with three full-size, one half-size expansion slots and room for two storage/backup systems.
- All Expansion systems are available with any combination of Everex hard disk drive and backup systems.

Replace the clumsy flat ribbon cable with Everex's *shielded, round* cable.

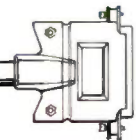

#### Unique Features:

- Advanced design eliminates "wait states" for faster data transmission
- Highest quality round cables (as IBM) instead of flat ribbon cables

### HARD DISK DRIVE SYSTEMS

Choose from a wide selection of models to meet your needs:

- space-saving internal systems
- external systems with extra expansion slots
- Capacities from 10 to 32 megabytes
- Factory tested for trouble-free operation

### GRAPHICS PRODUCTS

Everex offers a complete line of graphics products to choose from...

#### The Edge Color/Monochrome adapter

- Runs color software on your IBM monochrome display with a FULL SCREEN in 16 shades, no software patches needed
- High resolution, 720x348, monochrome graphics
- Operates Lotus 1-2-3, Symphony and other popular programs in an extended 132 column by 44 or 25 row display in HIGH resolution monochrome
- Printer connection

#### Graphics Edge Color/Monochrome adapter

Similar features as the Edge but also offers:

- More high resolution colors: 16 in 640x200 graphics



# OR EXCELLENCE



## The Company That Stands For Excellence...

- Displays the same information on a color AND monochrome monitor simultaneously

### **Dual Graphics** Color/Monochrome adapter

- Works with high resolution color AND monochrome displays
- Operates Lotus 1-2-3, Symphony and other popular programs in an extended 132 column by 44 or 25 row display
- More exciting colors: 16 colors in 640x200 and 320x200 graphics
- Printer connection

### **Graphics Pacer** Monochrome adapter and Floppy Disk Controller

- Runs sharp, high resolution monochrome graphics
- Operates up to four floppy disk and floppy tape drives
- Printer connection
- Uses only one expansion slot

### **Evergraphics** Monochrome adapter

- Operates crisp, high resolution monochrome graphics
- Includes printer and light pen connections

## **COMMUNICATIONS AND MULTIFUNCTION**

### **Evercom** Internal Modem

Gives you all of the features found in modems costing hundreds more:

- Fully Hayes and Bell 103/212A compatible
- Data transmission speeds in either 300 or 1200 bps
- Automatic dial and answer
- Works with tone and pulse phone systems
- Voice AND data communications
- Built-in speaker with software volume control
- Includes powerful, easy to use software

### **MagicCard** Multifunction adapter

- Adds more memory to your computer—up to 384K
- Serial connection for modems, printers, plotters and more
- Printer connection
- Game paddle/joystick connection
- Reliable clock/calendar with battery back-up
- FORM MANAGER electronic filing system and form creator
- PC WRITE easy to use word processing program
- With printer spooler, electronic disk drive and more

Excellence is the standard at Everex—it's in our name, our products, in everything we do. When you look for the best for your computer—you'll find Everex products.

Visit your local Everex dealer today and ask to see Everex products in action. For the name of your nearest Everex dealer, please call (415) 498-1111.

Dealer Hotline: (800) 821-0806. In CA (800) 821-0807.

Address: 47777 Warm Springs Blvd., Fremont, CA 94539 (415) 498-1111.

IBM, PC, XT and AT are registered trademarks of International Business Machines Corporation.

Excel, The Edge, Dual Graphics, Graphics Edge, Graphics Pacer, Evergraphics, Evercom and MagicCard are trademarks of Everex Systems Inc.

Form Manager is a trademark of BIT Software Inc.  
PC Write is a trademark of Quicksoft Inc.

**EVEREX**  
EVER for EXcellence



# CLUBS & NEWSLETTERS

## ● FUTURE INTELLIGENCE

A monthly newsletter devoted to tracking future computing technologies emphasizes research and business. Areas covered include artificial intelligence, supercomputers, parallel processing, expert systems, natural language, and voice/speech/pattern recognition and synthesis. An annual subscription is \$295. Contact Ed Rosenfeld, *Intelligence*, POB 20008, New York, NY 10025.

## ● BASED IN THE BAY

A nonprofit users group for Sanyo computerists, the Bay Area Sanyo Enthusiast (BASE) welcomes anyone interested in computers. Regular meetings are held. Contact Lee Swearingen at (813) 788-7865 or Dave Robbins at (813) 886-7751 or write BASE, POB 260517, Tampa, FL 33685.

## ● CHUGGING ALONG

The Capitol Heath Users Group (CHUG) meets on the third Monday of every month at the Fairfax High School in Virginia. Members operate two 24-hour bulletin boards at (703) 759-2072 and (703) 360-3812. CHUG sponsors an annual conference, houses special-interest groups, and produces a monthly newsletter, *CHUG*, which is included in the annual \$12 membership fee. Call John Roach in the evening at (703) 971-4930 or write CHUG, POB 10515, Alexandria, VA 22310.

## ● STANDARDS' BBS

The National Bureau of Standards' (NBS) Institute of Computer Sciences and Technology (ICST) has

established a BBS at (301) 948-5718. Open to the public, its purpose is to exchange information that assists federal agencies in the efficient selection of software and hardware. Among topics discussed are security and interfacing. For details on the project, contact Ted Landberg at ICST, NBS, 225 Room #A266, Gaithersburg, MD 20899, (301) 921-3485.

## ● JOIN CP/M EFFORT

CP/M SIG assists members in the technical aspects of CP/M and related software through monthly meetings, a monthly newsletter, and a 24-hour RCP/M system at (303) 465-1313. Article submissions are welcome. public-domain software is available, and lectures educate members on areas of interest. Discounts on hardware and software and a subscription to the newsletter are provided with payment of \$12 a year. Contact CP/M SIG Inc., POB 633, Broomfield, CO 80020-0633.

## ● GERMAN MAC RULES

At least once every two months, members of Club-mac (Europe) submit an article to the newsletter on anything about the Mac or their membership is not renewed. The result is a newsletter that keeps members up to date with latest developments, reviews new programs and hardware, and solves members' com-

puting problems. The annual membership fee is £25 per annum. Contact K. Leslie, Clubmac, Triererstrasse 8, D-5511 Wincheringen, West Germany.

## ● BCS GOES REGIONAL

The Monadnock Region IBM PC Users Group, a subgroup of the IBM PC Users Group of the Boston Computer Society (BCS), gathers in Keene, New Hampshire, to see demonstrations and meet with other users. By joining, you benefit from a software exchange, group-purchase discounts, a monthly newsletter, and automatic BCS membership with access to the BCS BBS. Contact Susy Thielen, 45 Kelleher St., Keene, NH 03431, (603) 352-0971.

## ● CALL THE AMATEURS

The bulletin board of the New York Amateur Computer Club (NYACC) is up and running. The bimonthly newsletter contains NYC users group meetings and contacts, a NYACC directory, events, articles, letters, and news. Meeting times and locations of several users groups are announced on a hotline at (212) 864-4595. The membership is \$15 annually; students pay \$10. Write the NYACC, POB 106, Church Street Station, New York, NY 10008.

## ● DOWN UNDER THE

TRS-80—Members of the Sydney TRS-80 Users Group

(SYDTRUG) share knowledge about hardware, software, and education, business, and related applications for TRS-80 computers. Communication occurs through the monthly newsletter containing news and reviews, plus lectures, demonstrations, and the 24-hour BBS (CLUB-80) in Australia on (02) 332-2494. The BBS features messages, group news, and the exchange of public-domain software. Meetings are held on the second and third Saturdays of each month in Botany, New South Wales. Write SYDTRUG, POB 43, Erskineville 2043, New South Wales, Australia, tel: (02) 772-2009.

## ● ENGINEERS ANALYZE

STRUCTURE—The Structural Analysis Programs Association (SAPA) upgrades the skills of engineers who use microcomputers to analyze and design buildings. Structural software and computer services that address this issue are discussed in the quarterly newsletter, *SAPA NEWS*, and in seminars held one full day in eight-month intervals. The annual membership fee is \$100. Contact J. Jeff Davies, SAPA, Suite D2, 30 Southeast Seventh St., Boca Raton, FL 33432, (305) 392-6597.

## ● BBS IN FOX RIVER

FORMS CLUB—Simplified Computer Solutions in Wisconsin has helped to form the Green Bay/Fox River Valley's bulletin-board service, SCS ABBS. The SCS Users Group evolved from the BBS and provides members with access to a library, group purchasing,

(continued)

.....  
*CLUBS & NEWSLETTERS is a forum for letting BYTE readers know what is happening in the microcomputing community. Emphasis is given to electronic bulletin-board services, club-sponsored classes, community-help projects, and other activities. We will continue to list new clubs and newsletters. Allow at least four months for your club's mention to appear. Send information to BYTE, Clubs & Newsletters, POB 372, Hancock, NH 03449.*



# PERSONALITY PROBLEM?

UNIX™ and DOS™ At the Same Time!

Looking at an IBM PC/AT? Happy with DOS but want UNIX? Happy with UNIX but want DOS? Want them working together?

## Get The Connector!™

The Connector is a revolutionary product that allows DOS applications to run on the IBM PC/AT or XT under VENIX/86 (the first licensed AT&T UNIX operating system for the IBM PCs) or PC/IX. That means you can add one or more terminals to your AT which run programs using multi-user VENIX/86 to share the disk and printer. Switch between UNIX and DOS at the console with a single command. And run more than one task simultaneously. Like running a spelling check in the background while you print a report and run Lotus 1-2-3™ or dBaseII™.

Get yourself an AT and load it with VENIX. Collect your DOS and/or UNIX applications. We'll supply The Connector. The right solution to your software personality problems.

Call for complete details.

Unisource Software Corp., Department 4109,  
71 Bent Street, Cambridge, MA 02141.  
Telex 92-1401/COMPUMART CAM.  
**617-491-1264**

Also  
available  
on the  
PC/XT and  
compatibles.



**Getting UNIX Software  
Down to Business**

\* UNIX is a trademark of AT&T Technologies, Inc. DOS is a trademark of Microsoft, Inc. PC/AT and PC/XT are trademarks of IBM. The Connector is a trademark of Uniform Software Systems, Inc. VENIX/86 implementation by VenturCom, Inc. 1-2-3 and LOTUS are trademarks of Lotus Development Corp. dBaseII is a trademark of Ashton-Tate.





COMPUTERBANC

# BANC ON U\$

GET SERIOUS. STOP PAYING HIGH PRICES NOW!

THOUSANDS OF AVAILABLE ITEMS. CALL FOR COMPLETE PRICING.

### SYSTEMS

**IBM PC**  
256K, Two 360KB Disk Drives, Color Graphics/Monochrome Graphics board, Parallel Printer Port, Monochrome Display (Amber/Green), DOS 2.1.  
LIST PRICE \$2950.00 — ONLY \$2095.00  
SUPER XT 10 Meg Upgrade ..... \$2795.00  
IBM AT ..... 11% OFF

### IBM SOFTWARE

LOTUS 1-2-3 ..... \$289.00  
LOTUS Symphony ..... 425.00  
MICROPRO Wordstar ..... 249.00  
ASCII Express For IBM ..... 125.00  
Wordstar Professional ..... 359.00  
Infostar ..... 249.00  
Multimate ..... 269.00  
MICROSOFT Word ..... 229.00  
Word W/Mouse ..... 279.00  
Multiplan ..... 139.00  
Project ..... 159.00  
ASHTON TATE Friday ..... 179.00  
dBASE II ..... 280.00  
dBASE III ..... 349.00  
Framework ..... 359.00  
LIFETREE SOFTWARE Volkswriter ..... 119.00  
Volkswriter Deluxe ..... 169.00  
FOX & GELLER Quickcode ..... 139.00  
dUtil ..... 59.00  
dGraph ..... 149.00  
MICRORIM Rbase: 4000 ..... 295.00  
PFS Write ..... 89.00  
File ..... 89.00  
Report ..... 89.00  
Proof ..... 79.00  
Access ..... 79.00  
ENERGRAPHICS ..... 269.00

### IBM HARDWARE

AST Six Pack Plus 64K ..... 259.00  
MegaPlus II ..... 259.00  
PC Net 1 Starter Kit ..... 830.00  
QUADRAM Quadboard O-K ..... 219.00  
Quadcolor 1 or Microfazer 64K ..... 205.00  
Quadlink ..... 479.00  
MICROSCIENCE  
10MB Winchester ..... 679.00  
FRANKLIN TELECOM  
10 Meg Harddisk ..... 719.00  
22 Meg Harddisk ..... CALL  
Cartridge backup ..... CALL  
HERCULES Mono Graphics ..... 329.00  
Color Card ..... 199.00  
ORCHID Turbo ..... CALL  
PC Net Starter Kit ..... CALL  
PLANTRONICS Colorplus ..... 389.00  
STB Rio plus 64K ..... 249.00  
Super Rio ..... 259.00  
Graphix + II NEW ..... 309.00  
AT Hardware ..... CALL  
TEAC 55B ..... 124.00  
55F ..... 180.00  
TANDON TM 100-2 ..... 179.00  
IBM Floppy 1.2 Meg ..... CALL  
TALL GRASS 12MB W/Tape ..... 2395.00  
RAM 64K upgrade set 9 ..... 35.00  
MOUSE SYSTEMS Optical Mouse ..... 189.00  
ALSO — XCOMP, PERSYST, ORCHID, TITAN AND OTHERS

### PRINTERS

BROTHER HR-15 ..... 369.00  
HR-25 ..... 619.00  
HR-35 ..... 859.00  
2024LQ ..... 915.00  
JUKI 6100 ..... 429.00

NEC 2030 ..... 659.00  
2050 ..... 799.00  
3530 ..... 1229.00  
3550 ..... 1539.00  
STAR MICRONICS Gemini 10X ..... 259.00  
Gemini 15X ..... 389.00  
EPSON RX-80 F/T ..... 329.00  
FX-80 ..... 349.00  
FX-100 ..... 649.00  
LQ1500 ..... 1299.00  
OKIDATA 92A ..... 389.00  
93A ..... 649.00  
84A ..... 949.00  
PANASONIC 1091 ..... CALL  
TOSHIBA 1350-P ..... 1399.00

### MONITORS

AMDEX 300 ..... 129.00  
300A ..... 145.00  
310A ..... 169.00  
Color I+ ..... 269.00  
Color II ..... 459.00  
TAXAN Composite Amber ..... 119.00  
121/122 ..... 149.00  
420 (RGB) ..... 439.00  
415 (RGB) ..... 489.00  
PRINCETON GRAPHICS HX-12 ..... 469.00  
SR-12 ..... 625.00  
MAX-12 ..... 189.00  
ZENITH ZVM-122 Amber ..... 95.00  
ZVM-123 Green ..... 95.00  
NEC 1201 Hi Res Green ..... 115.00  
1205 Hi Res Amber ..... 115.00  
1206 Green ..... 79.00  
JC1215 Composite Color w/audio ..... 215.00  
JC1216 Color RGB ..... 329.00

### MODEMS

HAYES 1200 ..... 469.00  
1200B ..... 389.00  
300 ..... 199.00  
Micromodem //e ..... 219.00  
ANCHOR Mark X ..... 109.00  
Mark XII ..... 249.00  
Volkmodem ..... 59.00  
NOVATION Smart Cat Plus ..... CALL  
Access 1-2-3 ..... 419.00  
Apple Cat II ..... 239.00  
J-Cat ..... 99.00  
PROMETHEUS Promodem 1200 ..... 329.00

### APPLE PRODUCTS

MICRO SCI A2 drives ..... 179.00  
RANA ELITE 1 ..... 219.00  
TEAC drive ..... 189.00  
APPLE Compatible drive ..... 169.00  
WESPER Interface ..... 69.00  
BUFFERED 16K ..... 139.00  
SYSTEMS SAVER Fan ..... 69.00  
MICROSOFT Premium //e ..... 279.00  
Softcard CP/M ..... 229.00  
Multiplan ..... 129.00  
MAC Multiple (Macintosh) Basic (Macintosh) ..... 129.00  
109.00  
APRICORN Serial Card ..... 69.00  
Z-80 Card ..... 59.00  
ASCII Express Professional ..... 89.00  
DISKETTES S/S ..... 12.00  
D/S ..... 19.00  
KOALA Touch Tablet ..... 79.00  
HAYES Mach III JoyStick ..... 39.00  
THUNDERCLOCK ..... 119.00  
APPLEMOUSE II ..... 129.00  
VIDEX Ultraterm ..... 179.00  
80 COLUMN/64K Interface//e only ..... 99.00  
80 COLUMN Card II+ only ..... 59.00

WE SUPPORT THESE FINE SYSTEMS: Apple, Compaq, IBM, and many more.

## CLUBS & NEWSLETTERS

conferencing on the BBS, and a monthly newsletter. The annual dues are \$10. Contact Don Sanderfoot, SCS, 2175 Wildwood Dr., Little Suamico, WI 54141.

### ● BUSINESS BBS

The Tulane University Business Bulletin Board (TUBBB) system combines business researchers, faculty, alumni, and students on line to share ideas, data, and programs. Contact John Page, A. B. Freeman School of Business, Tulane University, New Orleans, LA 70118.

### ● JOIN LONE STAR

The Lone Star Computer Club of Racine, Wisconsin, a group of users of all kinds of computers, meets at 7:30 p.m. on the second Thursday of each month at the Douglas Avenue Park Community House. The monthly newsletter, *President's Newsletter*, combines articles, software reviews, regular features, and library and system notes with applications. Contact H. S. Kanecki, Lone Star Computer Club, POB 93, Kenosha, WI 53140.

### ● VICTOR 9000 IN NW

The Victor 9000 Users Group serves users in Oregon and southern Washington state by meeting regularly to discuss the merits of the Victor 9000 business computer. A monthly newsletter, discount purchases, software demonstrations, and support for new users are group benefits. Contact Alan Bergen, 11765 Southwest Ebberts Court, Beaverton, OR 97005.

### ● KAYPRO IN BALTO

The Kaypro Users of Baltimore (KUB) meet at 7:30 p.m. on the first and third Wednesdays of every month at Loch Raven Middle School in Baltimore, Maryland. *The Bear Facts Newsletter* contains further in-

formation. The annual fee is \$12 and requires a blank disk as an initial contribution. Newsletter subscriptions are an additional \$6. Write KUB, POB 23510, Baltimore, MD 21203.

### ● ZORBA IN U.S.

The Zorba Equipment Users Society (ZEUS), a source of information and support for Zorba owners nationwide, maintains a public-domain library. The newsletter, *Oracle of Zeus*, is produced six times a year on disk and contains up to 30 files of relevant information. The \$25 annual membership fee covers a subscription to the newsletter. Contact Randy Brook, ZEUS, POB 1112, Athens, OH 45701.

### ● EXPLORING THE STARS

Users of MicroPro's WordStar and InfoStar can subscribe to two Stargazer newsletters, *Exploring WordStar* and *Exploring InfoStar*. Designed to unlock the potential of the programs, they supply information for solving application questions and clarifying documentation through a practical, hands-on approach. Members are encouraged to submit articles and can benefit from group-purchase discounts. Subscriptions are \$24 annually per newsletter or \$40 for both. Contact HI-Tech, Department B, 4 Harwood Dr., Glen Cove, NY 11542.

### ● MAC GETS TECHNICAL

A Macintosh Programming Journal, *MacTech*, reviews software development and programming exclusively for the Mac. Each month articles written by a panel will build on previous columns, enhancing readers' understanding of how to best apply Macintosh software technology. The subscription rate is \$24 a year. Contact *MacTech*, POB 846, Placentia, CA 92670. (714) 993-9939. ■

TELEX #550757 / ANSWER BACK — COMPUTERBANK UD



### Orders Only

## 800/332-BANC

OUTSIDE CALIFORNIA



## COMPUTERBANC

16783 Beach Blvd., Huntington Beach, CA 92647

714/841-6160

Inquiry 89

Cash prices indicated. All products are in factory sealed packages. We guarantee all items for 30 days, unless this period, effective merchandise returns must be accompanied by BANC order. All other returns will be subject to a 10% restocking fee. For dressed orders, there will be a 3% shipping charge, 5% for UPS Blue Label, \$5.00 minimum, all orders outside U.S.A. at 15% shipping.



# THE SIMPLE APPROACH IS THE SYMBOL APPROACH.

```
10 S=0
20 FOR I=1 TO 100
30 INPUT X
40 IF X = 0 GOTO 70
50 S=S+X
60 NEXT I
70 PRINT S/(I-1)
```

## BASIC

*A program to calculate averages...*

```
REAL X(100)
READ*,N,(X(I),I=1,N)
S=0
DO 10 I=1,N
10 S=S+X(I)
PRINT *,S/N
END
```

## FORTRAN

*just shrunk from seven lines...*

$(+ / X) \rightarrow \rho X \leftarrow \square$

## POCKET APL

*to one.*

## INTRODUCING POCKET APL™

Pocket APL, a new PLUS★WARE™ product, symbolizes a whole new way to solve problems. Faster than Fortran. Simpler than Basic. And at a cost much less than Cobol and many other programming languages. Its use of symbols makes it concise and efficient—powerful and productive.

### WORKING IN SHORTHAND = WORKING FASTER, SMARTER.

Pocket APL allows you to shrink the length of your programs. Because just a few symbols say what takes lines and lines to say in other programming languages. So Pocket APL cuts the drudgery and need for tedious sub-routines and long lists of commands.

### GET FLEXIBILITY > WITH CANNED SOFTWARE.

Pocket APL is a complete APL implementation with enhancements like online HELP, windowing, report formatting, dual file system, and debugging aids. It's also a powerful online calculator. So you don't have

to switch back and forth between programs or from your hand-held calculator to the computer.

And the symbols? Simple. You'll learn them fast. They'll become as second nature to you as +, -, ×, and ÷. Once you start using them, you'll be programming four to 10 times faster than with conventional languages. And as your needs grow, you can easily upgrade to STSC's APL★PLUS®/PC

System for even more features—like communications and graphics.

### POCKET APL COSTS MUCH < YOU'D EXPECT.

Pocket APL makes programming easy. And priced at just \$95, it's easy on the budget, too. It works with IBM PC's and compatibles and requires only 128K. So if problem-solving is taking up too much of your time, the answer is symbol. Pocket APL.

To order, or for more information, call 800-592-0050. In Maryland, call (301) 984-5123.

Or write STSC, Inc., 2115 East Jefferson St., Rockville, MD 20852. All major credit cards accepted.

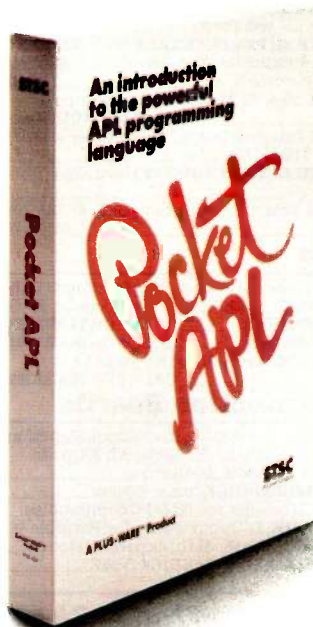

**Problem-solving at the speed of thought.**

**STSC**  
A Contel Company

Pocket APL uses a soft character set for computers with IBM-compatible graphics board or color monitor; keywords for computers with monochrome. Optional character generating ROM can be ordered for IBM PC monochromes or Hercules monochrome boards.

PLUS★WARE and Pocket APL are trademarks of STSC, Inc. APL★PLUS is a service mark and trademark of STSC, Inc., registered in the U.S. Patent and Trademark Office and in other countries.



# THE MAINFRAME

When one of twenty Micro Mart Sales Pros answers a call, he's ready at his PC.

Micro Mart's Ten Million Dollar Inventory is on-line with our IBM Mainframe, so answers are fast and accurate.

With PC to Mainframe Inventory, this Micro Mart Salesman verifies his stock, quotes his best price and makes the sale.

HELLO. THIS IS MICRO MART MAY I HELP YOU?

YESSIR! YOU WANT 85 OF THEM? I'M CHECKING OUR INVENTORY. ONE MOMENT, PLEASE...

THEY'RE IN STOCK! CAN I LOCK THEM IN FOR YOU? THANK YOU, SIR! WOULD YOU LIKE THEM TOMORROW?

## Computers

**CANON** Athena PC, Color or Monochrome Systems. AT INTRODUCTORY LOW PRICES **LEADING EDGE** Complete systems. FROM \$1495 **THE COMPUTER SPECIAL OF THE MONTH!** CALL FOR DETAILS!

## Networking / Protocol Conversion

**SNA & BISYNG** 3780, 5251 Mod 12 & Mod 11, 3274, 3278.  
**PC TURBO 186** by ORCHID, 80186 coprocessor board. \$799  
**IRMA** Complete line. FROM \$799  
**FORTEGRAPH** for IRMA, upgrades IRMA to 3279 S3G graphics.  
**IRMAPRINT** Enhances IRMA graphics.  
**PCnet** By ORCHID, complete line. FROM \$299  
**TECHLAND SYSTEMS** Blue Lynx 5251 Mod 12 & 3276 Emulators and 3270 Keyboards.  
**SANTA CLARA** PC Partner & PC Terminal. CALL

## Printers & Plotters

We have thousands in stock. **THE PRINTER SPECIAL OF THE MONTH!** CALL FOR DETAILS!

## HOUSTON INSTRUMENTS Plotters & Digitizers. Dot Matrix

**EPSON FX80 Plus/100 Plus.**  
**EPSON LX80/100.**  
**EPSON LQ1500.**  
**EPSON JX80,** color printer.  
**COMREX 420,** 400 cps. Epson compatible. \$1795  
**OKIDATA 92 & 93, ML84,** (200 cps.), w/opt. IBM PROMS, *Pacemark 2410* (350 cps.)  
**OKIDATA** Color printers. Complete line.  
**CANON** Color printers. Complete line.  
**TOSHIBA P-1351 & 1340.**  
**DATA PRODUCTS P. Series 8050 Color & 8070,** 132 col. 200 cps.  
**STAR MICRONICS** Complete line.  
**TEXAS INSTRUMENTS 855, 865 & 850XL.** FROM \$729

## Letter Quality

**NEC Spinwriters 2050, 3550, 8850.**  
**JUKI 6100/6300.** \$419 / \$749  
**C-ITOH Starwriter** (40 cps), *Printmaster*, (55 cps). \$899 / \$1299  
**COMREX CR35.**

We carry a full range of form handling options. Call for our unadvertised LQ Printers!!

## Floppy Disk Drives

**TANDON TM 100-2, DD/DS, 360K.** \$149  
**1/2 HEIGHT DISK DRIVES:** SHUGART, MITSUBISHI, TEAC. PC, XT & AT comp. FROM \$119  
**SPECIAL!** Two 1/2 H.DD "Y" cables & brackets. \$229



## Hard Discs

Micro Mart carries all the major brands. If you don't see it—ask for it.  
**PEACHTREE PERIPHERALS P-10, 20, 30 & 50,** internal & external. For your PC, XT, AT, AT&T, COMPAQ or others. FROM \$695  
**SYSGEN 10 & 20 Meg w/ streamer tape.** **NEW MODELS—CALL!**  
**SYSGEN Image & Quickfile,** streamer tape back-up for your IBM XT & AT. CALL  
**BERNOULLI TECHNOLOGY** Hard Disc Subsystems. \$2595  
**DAVONG** New line of hard discs. 21 & 32Mb w/tape. Start @ \$2495

## Chips

We guarantee the lowest price for chips!! Call us!!  
**INTEL 8087, 80287** High speed coproc. FROM \$129  
**64K RAMCHIPS.** CALL FOR MARKET PRICE  
**256K RAMCHIPS.** CALL FOR MARKET PRICE  
**128K PIGGY-BACK** Chips for your AT. CALL FOR MARKET PRICE

## Multifunction Boards

We have a complete line of multifunction boards compatible with the Portable, AT, XT, & Jr.  
**SIX PACK 64-384K,** multifunc.  
**MEGAPLUS 64-512K,** max. 8 func.  
**MPII RAMboards,** for PC & PC compatibles. CALL  
**1/0 MINNIE,** I/O shortboard for Portable & AT.  
**ADVANTAGE 128K-3Mb,** expansion for AT. CALL  
**QUADRAM QUADBOARD, 64-384K.** \$259

**QUAD Jr.** Expansion for PCjr.  
**TECMAR CAPTAIN, 0-384K** multifunc. \$199  
**TECMAR CAPTAIN Jr.,** Multifunction for Jr.  
**TALLTREE J-RAM II, 0-512K,** w/software.  
**TALLTREE J-RAM IIX, 0-512K,** w/software. \$129  
**STB RIO GRANDE & GRANDE BYTE,** Expansion for AT, 128K. FROM \$259  
**LEGACY** Complete line of expansion products for Jr. **THE BOARD SPECIAL OF THE MONTH!** CALL FOR DETAILS

## Graphic Cards

**PREVIEW** Monochrome graphics. Hercules look-alike for less. CALL  
**HERCULES Mono & color** graphics cards, supports Lotus.  
**PLANTRONICS ColorPlus + HiRes** color board, par. port w/software. **New low price!**  
**TECMAR Graphics Master,** HiRes color & mono supports Lotus. \$459  
**QUADRAM Quadcolor I & II,** color cards.  
**PARADISE SYSTEM** Multi-display or Mod. Graphics Cards, color & mono, par. port. FROM \$299

## Software

**ASK ABOUT THE SOFTWARE SPECIAL OF THE MONTH!**  
**Accounting**  
**SORCIM / IUS** Complete line including windows. FROM \$279 / EA.  
**BPI ACCOUNTING** Complete line.

**MICRO MART HAS OVER 20 STORE LOCATIONS. CALL FOR THE ONE NEAREST YOU.**

# (404) 449-8089

Prices are subject to change without notice and are similar, but may vary at Micro Mart Retail Stores.

### Service & Repairs

- On-Site—We have hundreds of service locations nationally.
- Depot—Our National Service Center is one of the fastest in the U.S.
- We Have—A wide variety of services available. Please call us.



orders only

# EVENT. 1-800-241-8149.

As the order is processed, each product is thoroughly tested before shipping.

Micro to Mainframe Order Entry and Processing is fast... then we can ship by Federal Express for next day delivery.

The result? Some very satisfied Micro Mart Customers!



GREAT JOB GETTING THAT PC STUFF, DOCTOR!

## Modems

**HAYES Smartmodem 300, 1200, 1200B & 2400.** The best stock in the U.S. **CALL PROMETHEUS Modems.**

**ANCHOR AUTOMATION Signalman Mk XII. \$259**  
**VEN-TEL 1200 BAUD 1/2 Card** for IBM Port. & XT.  
**POPCOM Popcom, Int. & ext.** w/voice and data comm.

## Miscellaneous

**DYSAN DISKETTES, PC, XT, & AT compatible.** GUARANTEED LOWEST PRICE IN THE U.S. **CALL!**

**MOUSE SYSTEMS PC** Mouse, optical w/ software.  
**MICROSOFT MOUSE** Bus or serial mechanical mouse w/ mouse menu software.

**KEYTRONICS 5150 & 5151.** PC and Jr. Keyboards  
**KENSINGTON MICROWARE** Master Piece. **\$119**  
**CURTIS** Accessories. Pedestals, cables, etc.  
**EDP** Best selling line of surge protectors. **FROM \$35**

## Spreadsheets & Integrated Packages

**ASHTON-TATE Framework.**  
**LOTUS Symphony and Lotus.** **\$299 / \$429**  
**MICROSOFT MultiPlan, w/ templates.**  
**MDBS Knowledge Man.**  
**SORCIM / IUS SuperCalc 3, vers. 2.0.** **NEW LOW PRICE!**

**SPI Open Access.**

## Enhancements & Utilities

**FOX & GELLER** Complete line of enhancements for dBase II, III & Rbase 4000.  
**NORTON Utilities 3.0.** **\$69**  
**ROSESOFT ProKey 3.0.** **\$89**  
**CENTRAL POINT SOFTWARE Copy II PC.** **\$35**  
**ATI Training** **\$55**  
**SOFTSTYLE Set Fx + and Printworks.** Printer control pkgs.  
**SIDEWAYS** Inverts printout. **\$45**  
**BORLAND Sidekick.**  
**LIVING VIDEO TEXT Think Tank.** **\$125**

## Compilers & Language Tools

**LATTICE C-Compilers.** **\$299**  
**MICROSOFT Complete line.**  
**WORDTECH The dBase compiler.**  
**DIGITAL RESEARCH Complete line.**  
**BORLAND Turbo Pascal, Turbo Toolbox and more.** **FROM \$35 / EA.**

## Graphics & CAD

Micro Mart carries all the major CAD packages. Call if you don't see it.  
**Zsoft PC Paint Brush, mouse driven graphics.** **\$95**  
**DECISION RESOURCES ChartMaster / Sign-Master pkgs.**  
**MICROPRO ChartStar.**  
**MICROSOFT Chart.**

## Communications

**MICROSTUF CROSSTALK XVI.** Latest version. **\$99**  
**HAYES SMARTCOM II.**

## Word Processors

**MULTIMATE w/ Spelling checker & tutorial.** **\$259**  
**SAMNA +** word processor.  
**MICROSOFT Word.** New version.  
**LIFETREE Volkswriter Deluxe.** **\$169**  
**SSI WordPerfect.** New version.  
**WORDMARC Wordmarc.**

## Office & Project Planning

**HARVARD Total Project Manager.** **\$299**  
**SORCIM / IUS Super Project.**  
**MICROSOFT Project.**

## Data Base Managers

**MICROIM 4000 or 6000, Report Writer & Clout** options. **New low price!**  
**WARNER SOFTWARE** The desk organizer. **\$145**  
**ASHTON-TATE dBase II & III.** AT compatible.  
**MICROSTUF Infoscope.**

**HAYES Mach II & Mach III Joysticks.**  
**QUADRAM Microfazer.** Printer buffer 8-128K. **FROM \$129**  
**TRIPPELITE** Back-up power supply. 200-1000 watts, and **ISOBAR** surge protectors. 4 & 8 plug.  
**RUTISHAUSER** Sheet feeders for all major brands.  
**POLAROID Palette.**

## Monitors and CRT's

**PGS Max12, Amber, 720h x 350v.** Monochrome. **PGS SR-12 690h x 480v, w/ dual scan cd.**  
**PGS HX-12, 690 Dot RGB.**  
**QUADRAM Quadochrome, 690 Dot RGB.** **\$439**  
**QUADRAM Amberochrome, Amber mono.** **\$159**  
**AMDEK Color 300, 500, 600, 700, 710, 722.** New complete line of HiRes RGB's with new low prices.  
**AMDEK 300A/300G Composite mon.** **\$129 / \$119**  
**AMDEK 310A, Amber w/3 yr. warranty.** **In Stock!**  
**WYSE Terminals, 100, 75, 50.** Entire line in stock.  
**TAXAN RGB Color Monitors.** Complete line at low, low prices. **CALL!**

© Copyright Micro Mart 1985  
 Technology Corporate Campus  
 3159 Campus Drive  
 Norcross, Georgia 30071

America's PC Specialist.

# MICRO MART

IBM is a registered trademark of International Business Machines Corporation.

YOUR PERSONAL BLUE CHIP CARD



1234 567 890 123

Micro Mart has financing options available. Ask for a Micro Mart Blue Chip Credit Card application, today.



# THE FASTEST LINK

FROM MICRO

TO MAINFRAME



## BARR/HASP: POWERFUL, VERSATILE, EASY TO USE for the IBM PC, XT, AT and compatibles includes software, synchronous adapter board and manual

The BARR/HASP Intelligent Communications package provides more than just a connection—it's powerful enough to drive multiple high-speed printers for volume printing, yet versatile enough to print checks and invoices on any size printer. With the menu-driven software, you can perform all program functions accurately, easily, and without lengthy training.

BARR/HASP emulates a full function IBM 3777-2 and HASP on the 360/20. Print speeds on single and multiple printers range from 30 cps to beyond 2,400 lpm (7,000 lpm on the PC AT). Line speeds range from 1,200 to 9,600 Baud on dial-up and to 19,200 Baud on a dedicated line. With the PCAT, you can achieve a new speed record for a micro-computer—56,000 Baud—and drive even the fastest laser printers at maximum efficiency.

All tasks—printing, plotting, sending jobs, and using the console—operate simultaneously from a single PC. Such high performance translates into instant savings. BARR/HASP now replaces expensive, cumbersome Remote Job Entry workstations—and does it for a fraction of the cost.

You'll find the BARR/HASP manual complete and refreshingly intelligible. But should you have a question, BARR's technical experts are just a toll-free phone call away.

### FREE 30-DAY TRIAL

See for yourself how the BARR/HASP Link can work for you. For a free 30-day trial, call

**800-BARR-SYS**  
**(800-227-7797)**

in NC, call 919-782-4462



Host Systems:	MVS/JES2 MVS/JES3	VM/RSCS VS1/RES	NOS/RBF MVT/HASP
Requires:	128K synchronous modem		



**BARR SYSTEMS, INC.**

2500 Blue Ridge Road, Suite 315  
Raleigh, NC 27607



# B·O·O·K R·E·V·I·E·W·S

BUILD YOUR OWN  
EXPERT SYSTEM  
Chris Naylor  
John Wiley & Sons  
New York: 1985  
246 pages, \$13.95

ARTIFICIAL  
INTELLIGENCE IN BASIC  
Mike James  
Focal Press  
Stoneham, MA: 1984  
122 pages, \$14.95

THE COGNITIVE  
COMPUTER: ON  
LANGUAGE, LEARNING,  
AND ARTIFICIAL  
INTELLIGENCE  
Roger C. Schank  
with Peter G. Childers  
Addison-Wesley  
Reading, MA: 1984  
282 pages, \$17.95

---

BUILD YOUR OWN  
EXPERT SYSTEM  
Reviewed by  
Ramachandran  
Bharath

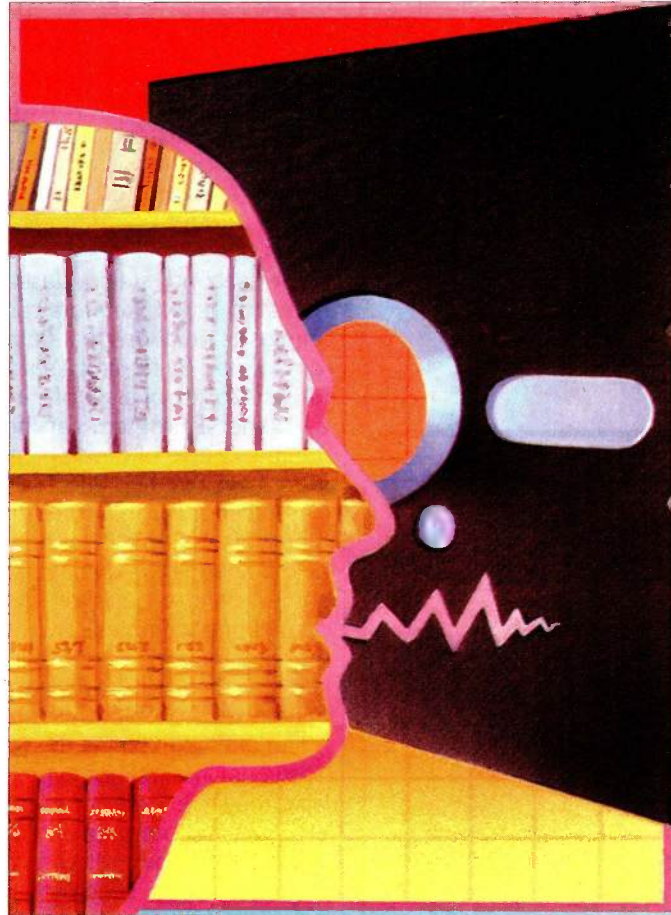

An increasing number of comprehensive introductions to expert systems—computer programs that emulate the decision making of human experts—have been published recently. Two examples are *Building Expert Systems* by Frederick Hayes-Roth (Reading, MA: Addison-Wesley, 1983), and *A Practical Guide to Designing Expert Systems* by Sholom M. Weiss and Casimir A. Kulikowski (Totowa, NJ: Rowman and Allanheld, 1984).

But the object of Chris Naylor's book, *Build Your Own Expert System* (originally published in the United Kingdom in 1983), is to help home computer users write expert systems that learn.

John F. Sowa, author of *Conceptual Structures: Information Processing in Mind and Machine* (Reading, MA: Addison-Wesley, 1983), groups expert systems into three categories based on the kinds of problems they address: classification (such

as diagnosis of disease), design (of chips, for example), and decision support. Naylor's book is aimed essentially at teaching readers about classification problems.

Naylor begins with a good discussion of the general advantages and limitations of current expert systems. He follows this with a chapter on statistical and probability theories; he provides the essentials of elementary probability theory and discusses revising initial estimates of probabilities in light of relevant additional information. (The technique for such revision of initial estimates is known as Bayes' theorem.) Naylor introduces these concepts extremely well by relating them to an expert system the reader might want to build: a program for forecasting weather using information on current conditions of fog, humidity, temperature, etc.

After providing this background, the author leads the reader through the process of developing a general BASIC program that can solve a broad range of classification problems. The process includes a BASIC program that asks the user questions regarding the variables relevant to the problem and the outcomes possible in the problem. The program then must be given examples of the different outcomes and of the values of the associated variables. The program can handle any problem that has these characteristics: a set of variables relevant to the problem; different outcomes distinguished by a different pattern of values for the variables; and the pattern of values of the variables indicates which outcome would result.

A concrete example of this abstract definition is medical diagnosis. Here, the pattern (symptoms) tells the doctor

(continued)



## COMPUTER COURSES:

"Structured Programming in BASIC" for IBM PC

"Microprocessing Essentials" includes Microtrainer 2, four interface boards, and power supply.

Both are university level courses.

## TEACHING HARDWARE:

Microtrainer 2: 6800-based single board computer  
 Microtrainer 68K: 68000-based single board computer  
 Interface Boards: Demonstrate practical digital circuits  
 EPROM Programmer  
 Power Supply: 5V regulated 1.5A bench supply  
 6800 Assembler, runs on IBM PC  
 68000 Assembler, runs on IBM PC  
 Classroom Logic Trainer and Student Supplies  
 Write or phone for free brochures. Quantity discounts available.



Waterloo Distance Education  
 279 Weber St. N., Unit 17  
 Waterloo, Ont. Canada N2J 3H8  
 (519) 884-4340

Waterloo Distance Education  
 1051 Clinton St.  
 Buffalo, N.Y.  
 14206

## BEFORE YOU BUY CABLE ASSEMBLIES,

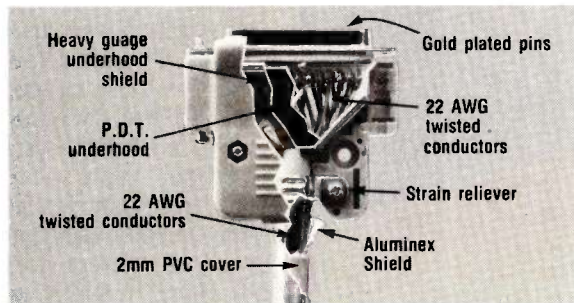

## CHECK UNDER THE HOOD!

DATA SPEC™ cable assemblies are the very best. Each cable is fully shielded to exceed FCC EMI/RFI emission requirements. The unique P.D.T. technique, introduced by DATA SPEC™ and employed beneath the hood shield, insures maximum integrity under the most adverse conditions. DATA SPEC™ has interface cables for all your requirements: Printers, Modems, Monitors, Disk Drives, and much more. And all DATA SPEC™ cable assemblies carry a lifetime warranty. Insist on DATA SPEC™ cables in the bright orange package. Available at better computer dealers everywhere. For more information, call or write:

# DATA SPEC™

A Division of Alliance Research Corporation

20120 Plummer Street • Chatsworth, CA 91311 • (818) 993-1202

Copyright © 1984 by Alliance Research Corporation

Patent PND.

## BOOK REVIEWS

which outcome (disease) is indicated. The pattern is represented by a set of variables: a 1 in a particular variable means the symptom that variable represents is present; a 0 stored means it is not. Another example is a fault-diagnosis problem to test Naylor's expert program. In this problem, the possible variables are the faults you might observe in a cassette recorder: no lights; tape won't move; unit won't record; intermittent sound; distorted sound; erratic speed; and hum. Depending on which subset of these seven variables is operative, you can determine which outcome (or fault) you should diagnose, such as the switch is off, the tape jammed, the tape was inserted wrongly, the head is dirty, or there's a problem with the amplifier. (An optional extension of this is incorporated in a listing.) Using the diagnosis as the input, the extension offers as output a suggested remedial action—clean the head, switch on the recorder, etc.—that is, it is a two-node (or two-stage) classification problem.

The second stage classifies the faults to produce remedial action. Readers can come up with their own examples of situations that fit this general classification-problem format. By finding a suitable problem that relates different subsets of a set of variables to different outcomes, the general program can be used for diagnosis.

In the course of developing this general program, Naylor introduces the theoretical concepts underlying the general classification problem, referred to in texts on statistical theory as multiple discriminant analysis (the problem of discriminating or distinguishing between different outcomes on the basis of information regarding the discriminating variables). By the time readers work through the explanations of each line of the program and what it does, they will have learned useful statistical theory related to a problem that holds their interest.

The author explains the fundamental basis of all diagnostic or classification-type expert systems. He illustrates how they are essentially a set of IF (set of symptoms) THEN (corresponding outcome or diagnosis) statements. These are usually referred to as "production rules." He discusses major successful expert systems, like MYCIN, for medical diagnosis; Prospector, for geological prospecting; and DENDRAL, for chemical analysis. The book is worth reading just for this lucid explanation of the basis of current systems and for the discussion of making a program so specific to a particular problem area that it cannot be easily adapted to a different problem area. In contrast, the programs Naylor teaches readers to build are of the learning type; that is, on the basis of examples of different types of problems, they can learn to diagnose problems in different areas. He points out that the disadvantage of this is that such a general program would not be as efficient as one built for a specific purpose.

### SUMMARY

I highly recommend this book for several reasons. It provides a simple yet insightful discussion of extant successful

(continued)





Not long ago, *PC Magazine* called MDBS III "The most complete and flexible data base management system available for microcomputers." That's a powerful statement. But then, MDBS III is an amazingly powerful software package. So powerful, in fact, that it lets you build mainframe-quality application systems on your micro or mini. MDBS III is not for beginners. It's for application developers with large data bases or complex data interrelationships who want to define data base structures in the most natural way—without resorting to redundancy or artificial constructs. It's for professionals who can appreciate its extensive data security and integrity features, transaction logging, ad hoc query and report writing capability and its ability to serve multiple simultaneous users. And if you want the power and the glory that only the world's most advanced data management system can provide, MDBS III is for you. For information on MDBS III and our professional consulting services, write or call Micro Data Base Systems, Inc., MDBS/Application Development Products, 85 West Algonquin Road, Suite 400, Arlington Heights, IL 60005. (800) 323-3629, or (312) 981-9200. **MDBS III. ABSOLUTE POWER.**

Inquiry 258

# WE'LL GIVE YOU THE POWER.

# YOU TAKE THE GLORY.





## ONLY PUBLIC DOMAIN SOFTWARE

is uncopyrighted, so no license fees to pay to anyone! Thousands of useful dbase, spreadsheet, word processors, games, utilities and business programs you can copy yourself from our User Group rental libraries. Join hundreds of companies and users enjoying a wealth of inexpensive software!

<b>RENTAL LIBRARIES FOR CP/M</b>	
SIG/M UG (New Jersey Area Computer Club)	
216 Disk Sides .....	\$125.00
<b>CP/M UG (New York Area Computer Club)</b>	
92 Disk Sides .....	\$45.00
<b>PICONET (Bay Area User Group)</b>	
34 Disk Sides .....	\$25.00
<b>KUG (Charlottesville Kaypro User Group)</b>	
25 Disk Sides .....	\$25.00
<b>NATIONAL EPSON UG</b>	
32 Disk Sides .....	\$35.00
<b>PD DIRECTORY CATALOG DISK</b>	
<b>SPECIAL SALE</b> —includes CP/M, SIG/M UG & PNET ..	\$5.00 pp
<b>RENTAL LIBRARIES FOR IBM PC DOS</b>	
<b>PC-BLUE (NYACC)</b>	
82 Disk Sides .....	\$85.00
<b>IBM-PC SIG (Santa Clara Group, others)</b>	
230 Disk Sides .....	\$250.00
<b>RENTAL LIBRARIES FOR COMMODORE 64</b>	
28 Disk Sides .....	\$25.00
<b>PD DIRECTORY BOOKLET</b> .....	\$12.00 pp

Rental is for 7 days after receipt. 3 more days grace for return. Use your credit card — NO DISK DEPOSIT! Most formats available—even Apple! Specify. Software also available for sale, \$6.00 per disk full.

24 hr., 3 minute info. recording

(619) 727-1015

**NATIONAL PUBLIC DOMAIN RENTAL CENTER**

1533 Avohill Dr., Vista, CA 92083

(619) 941-0925 Orders



## BOOK REVIEWS

expert systems. It teaches the basic principles of statistical theory, production rules, learning algorithms, and so forth in a practical way and provides a technical summary at the end of the book for reference. The book contains a program for an expert system that is based on an application of Bayes' theorem.

Running the program in chapter 7 helped immensely in following Naylor's explanations. Also, verifying that the sample program produced the results indicated by the author confirmed that I was on the right track. The programs are given in Apple II and Spectrum versions of BASIC. The reader with access to a different system (I had to modify the learning program for the IBM Personal Computer) becomes painfully aware of the difficulty of understanding the logic of another person's BASIC program when it is written in a version that uses only single-letter names for variables. Naylor mentions the unsuitability of BASIC for these types of programs; his choice was based on the fact that it is the language most commonly available for home computers. Now that microcomputer versions of a more suitable language, Prolog, are becoming available, I hope Naylor's next edition of the book will provide micro-PROLOG listings as well.

*Ramachandran Bharath is a professor in the Department of Management, Marketing, and Data Processing at Northern Michigan University (Marquette, MI 49855).*

### ARTIFICIAL INTELLIGENCE IN BASIC

Reviewed by Norman J. Chaplin

The artificial intelligence (AI) invasion that was once predicted has now arrived. In fact, this intelligence has established itself in the areas of intelligent games, decision analysis, and expert systems, in addition to programs that correct spelling and grammar.

Mike James, the author of *Artificial Intelligence in BASIC*, believes the best way to comprehend the scope of AI is to gain experience in it. He recommends using BASIC, which is both widely understood and easily read.

To illustrate different techniques, James uses a few simple problems that are repeated in various branches of AI. He provides practical programs that can be entered without prohibitive effort from a keyboard. His BASIC dialect is a standard Microsoft version without special features; it can be adapted readily to most home computers.

James uses a heuristic attack on the familiar nine-square problem (arrange 8 numbered tiles in numerical order within a 3 by 3 array). He defines a heuristic rule as one that, when applied, tends to make the result move closer to the solution. With a heuristic, as opposed to an algorithm, there is no guarantee that a solution will be found. The path of the heuristic may be diverted into a closed loop of repeating positions. The program prints the board position to the screen every two to four moves and prints out the total number of moves taken to reach

## NOW... SEE SPEED YOU'VE NEVER SEEN BEFORE ON THE HP 150 PERSONAL COMPUTER HP 150 with COPROCESSOR



- Precise high-speed computation.
- Enhanced with **8087** numeric data coprocessor that provides up to 100 times the performance of the standard 8088 CPU alone.
- Add-on cards provide analog-to-digital and digital-to-analog capability for wide variety of applications in science, industry, and medicine.
- Graphics capability enables HP 150 to be used as digital oscilloscope for real time signal display.

For more information contact:  
**CLINICAL MICROSYSTEMS, INC.**

P.O. Box 36-1055  
Melbourne, Florida 32936  
**(305) 723-5475**

a solution. Although many of my attempts ended in continual cycling through a particular sequence of moves, I generally solved the problem in twenty to sixty moves, and sometimes in as few as seven or eight.

**MAN AND MACHINE**

The opening chapter discusses "Your Computer's IQ," "Computer-Aided Intelligence," and "What is Intelligence?" In the sections on pattern recognition and speech production and recognition, James admits that these subjects are too much for BASIC and are best handled with dedicated hardware. A discussion of grammar leads to an example of English generated by a computer. "Thinking, Reasoning, and Problem Solving" deals with mathematical theorem proving, cybernetics, and human associative memory.

Man teaches machine in chapters 4, 5, and 6. Man instructs the program Aardvark to recognize animals. To accomplish this, Aardvark asks a series of questions to build up its inventory of identifiable animals until it becomes an expert in animal identification. Aardvark is rudimentary, but with some expansion it could become a practical program, useful in fields such as mineral identification. I used it for bird identification.

"Structure of Memory" discusses the problem of memory-recall and explains computer solutions such as relational stores and conceptual databases. James fully illustrates the conceptual database problem with the Tom the Cat program, which solves the recall problem using a number of corresponding matrices. If you enter TOM IS A CAT: CAT HAS FUR: and then inquire, Does Tom have fur? the program answers YES. (Tom wouldn't run until I eliminated its bugs.)

**LANGUAGE AND PHILOSOPHY**

Another chapter deals with language: syntax, parsing, and semantics. Several pages cover Eliza, the psychotherapy program. There is also a listing and description of a BASIC program, Chat, that generates English sentences.

The last chapter is about philosophy. Can a computer program be intelligent? Or merely very clever? What about awareness? Should the Turing test be modified to measure artificial intelligence? The theme of this book could be summarized in James's words: "There is nothing very different about intelligent programs and they can be understood without any difficult theory." Neurophysiology shows us how small groups of neurons work, functions that we can duplicate electronically. Psychology, however, is so general that it can provide little practical guidance. James emphasizes that the third-generation software beginning to appear is characterized by the assumption that any misunderstandings are the program's fault, and the program will attempt to correct its mistake by learning the meaning of the new input from the user. This could be interpreted as intelligent behavior. I loaded a Commodore 64 with the Chat program, made a few changes, and found

(continued)

High performance to cost ratio...

**Programming Chips?**

Projects develop profitably with development hardware /software from GTEK.



**MODEL 7956** .....  
 (with RS232 option) .... \$1099.  
**MODEL 7956** (stand alone) \$ 979.  
 GTEK's outstanding **Gang Programmer** with intelligent algorithm can copy 8 EPROMS at a time! This unit is used in a production environment when programming a large number of chips is required. It will program all popular chips on the market through the 27512 EPROMS. It also supports the Intel 2764A & 27128A chips. It will also program single chip processors.



**MODEL 7228 - \$599**  
 This model has all the features of Model 7128, plus **Intelligent Programming Algorithms**. It supports the newest devices available through 512Kbits; programs 6x as fast as standard algorithms. Programs the 2764 in one minute! Supports Intel 2764A & 27128A chips. Supports Tektronics, Intel, Motorola and other formats.

EPROM & PAL

**PROGRAMMERS**

—These features are standard from GTEK—

Compatible with all RS232 serial interface ports • Auto select baud rate • With or without handshaking • Bidirectional Xon/Xoff • CTS/DTR supported • Read pin compatible ROMS • No personality modules • Intel, Motorola, MCS86 Hex formats • Split facility for 16 bit data paths • Read, program, formatted list commands • Interrupt driven — program and verify real time while sending data • Program single byte, block, or whole EPROM • Intelligent diagnostics discern bad and/or erasable EPROM • Verify erasure and compare commands • Busy light • Complete with Textool zero insertion force socket and integral 120 VAC power (240 VAC/50Hz available) •



**MODEL 7324 - \$1199**  
 This unit has a built-in compiler. The Model 7324 programs all MMI, National and TI 20 and 24 pin PALs. Has non-volatile memory. It operates stand alone or via RS232.



**MODEL 7128 - \$429**  
 This model has the highest performance-to-price-ratio of any unit. *This is GTEK's most popular unit!* It supports the newest devices available through 256Kbits.

**MODEL 7316 Pal Programmer** ..... \$ 599  
 Programs Series 20 PALs. Built-in PALASM compiler.

**DEVICES SUPPORTED**

by GTEK's EPROM Programmers

	NMOS	NMOS	CMOS	EEPROM	MPU'S
2758	2764A	2508	68764	27C16	5213 12816A 8748 8741H
2716	27128	2516	8755	27C16H	5213H 12817A 8748H 8744
2732	27128A	2532	5133	27C32H	52B13 8749H 8751
2732A	27256	2564	5143	27C64	X2816 8741 68705
2764	27512	68766	27C256	48016	8742H

**UTILITY PACKAGES**

GTEK's **PGX Utility Packages** will allow you to specify a range of addresses to send to the programmer, verify erasure and/or set the EPROM type. The **PGX Utility Package** includes **GHEX**, a utility used to generate an Intel HEX file.

**PALX Utility Package** — for use with **GTEK's Pal Programmers** — allows transfer of **PALASM**® source file or ASCII HEX object code file.

Both utility packages are available for CPM,® MSDOS,® PCDOS,® ISIS® and TRSDOS® operating systems. Call for pricing.

**AVOCET CROSS ASSEMBLERS**

These assemblers are available to handle the 8748, 8751, Z8, 6502, 68X and other microprocessors. They are available for CPM and MSDOS computers. When ordering, please specify processor and computer types.

**ACCESSORIES**

Model 7128-L1, L2, L2A	Call for pricing	XASM (for MSDOS) .....	\$250.
(OEM Quantity)	\$259.	U/V Eraser DE-4 .....	\$ 80.
Model 7128-24	\$329.	RS232 Cables .....	\$ 30.
Cross Assemblers	\$200:	8751 Adapter .....	\$174.
		8755 Adapter .....	\$135.
PGX Utilities	Call for pricing	48 Family Adapter .....	\$ 98.
PALX	Call for pricing	68705 Programmer .....	\$299.



Development Hardware/Software  
 P.O. Box 289, Waveland, MS 39576  
 601/467-8048  
 , INC.

GTEK, PALASM, CPM, MSDOS, PCDOS, ISIS, and TRSDOS are all registered trademarks.



## 64K S100 STATIC RAM

**\$159<sup>00</sup>**  
KIT

**NEW!**

LOW POWER!  
150 NS ADD \$10



BLANK PC BOARD  
WITH DOCUMENTATION  
\$49.95

SUPPORT ICs + CAPS  
\$17.50

FULL SOCKET SET  
\$14.50

FULLY SUPPORTS THE  
NEW IEEE 696 S100  
STANDARD  
(AS PROPOSED)

FOR 56K KIT \$145

ASSEMBLED AND  
TESTED ADD \$50

### FEATURES: **PRICE CUT!**

- \* Uses new 2K x 8 (TMM 2016 or HM 6116) RAMs.
- \* Fully supports IEEE 696 24 BIT Extended Addressing.
- \* 64K draws only approximately 500 MA.
- \* 200 NS RAMs are standard. (TOSHIBA makes TMM 2016s as fast as 100 NS. FOR YOUR HIGH SPEED APPLICATIONS.)
- \* SUPPORTS PHANTOM (BOTH LOWER 32K AND ENTIRE BOARD).
- \* 2716 EPROMs may be installed in any of top 48K.
- \* Any of the top 8K (E000 H AND ABOVE) may be disabled to provide windows to eliminate any possible conflicts with your system monitor, disk controller, etc.
- \* Perfect for small systems since BOTH RAM and EPROM may co-exist on the same board.
- \* BOARD may be partially populated as 56K.

**256K S-100 SOLID STATE DISK SIMULATOR!**  
WE CALL THIS BOARD THE "LIGHT-SPEED-100" BECAUSE IT OFFERS AN ASTOUNDING INCREASE IN YOUR COMPUTER'S PERFORMANCE WHEN COMPARED TO A MECHANICAL FLOPPY DISK DRIVE.

### PRICE CUT!

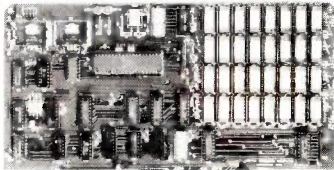

BLANK PCB  
(WITH CP/M\* 2.2  
PATCHES AND INSTALL  
PROGRAM ON DISKETTE)  
\$69.95  
(8203-1 INTEL \$29.95)

#### FEATURES:

- \* 256K on board, using + 5V 64K DRAMS.
- \* Uses new Intel 8203-1 LSI Memory Controller.
- \* Requires only 4 Dip Switch Selectable I/O Ports.
- \* Runs on 8080 or Z80 S100 machines.
- \* Up to 8 LS-100 boards can be run together for 2 Meg. of On Line Solid State Disk Storage.
- \* Provisions for Battery back-up.
- \* Software to mate the LS-100 to your CP/M\* 2.2 DOS is supplied.
- \* The LS-100 provides an increase in speed of up to 7 to 10 times on Disk Intensive Software.
- \* Compare our price! You could pay up to 3 times as much for similar boards.

**\$229<sup>00</sup>**

#LS-100 (FULL 256K KIT)

## THE NEW ZRT-80 CRT TERMINAL BOARD!

A LOW COST Z-80 BASED SINGLE BOARD THAT ONLY NEEDS AN ASCII KEYBOARD, POWER SUPPLY, AND VIDEO MONITOR TO MAKE A COMPLETE CRT TERMINAL. USE AS A COMPUTER CONSOLE, OR WITH A MODEM FOR USE WITH ANY OF THE PHONE-LINE COMPUTER SERVICES.

#### FEATURES:

- \* Uses a Z80A and 6845 CRT Controller for powerful video capabilities.
- \* RS232 at 16 BAUD Rates from 75 to 19,200.
- \* 24 x 80 standard format (60 Hz).
- \* Optional formats from 24 x 80 (50 Hz) to 64 lines x 96 characters (60 Hz).
- \* Higher density formats require up to 3 additional 2K x 8 6116 RAMS.
- \* Uses N.S. INS 8250 BAUD Rate Gen. and USART combo IC.
- \* 3 Terminal Emulation Modes which are Dip Switch selectable. These include the LSI-ADM3A, the Heath H-19, and the Beehive.
- \* Composite or Split Video.
- \* Any polarity of video or sync.
- \* Inverse Video Capability.
- \* Small Size: 6.5 x 9 inches.
- \* Upper & lower case with descenders.
- \* 7 x 9 Character Matrix.
- \* Requires Par. ASCII keyboard.

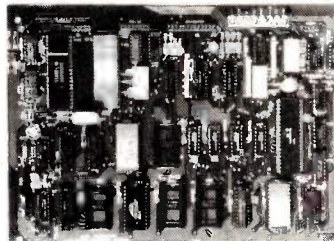

BLANK PCB WITH 2716  
CHAR. ROM, 2732 MON. ROM

**\$49.95**

SOURCE DISKETTE - ADD \$10  
SET OF 2 CRYSTALS - ADD \$7.50

WITH 8 IN.  
SOURCE DISK!  
(CP/M COMPATIBLE)

**\$99.95** (COMPLETE KIT,  
# ZRT-80 2K VIDEO RAM)

## Digital Research Computers

P.O. BOX 461565 • GARLAND, TEXAS 75046 • (214) 225-2309

Call or write for a free catalog on Z-80 or 6809 Single Board Computers, SS-50 Boards, and other S-100 products.

TERMS: Add \$3.00 postage. We pay balance. Orders under \$15 add 75¢ handling. No C.O.D. We accept Visa and MasterCard. Texas Res. add 5-1/8% Tax. Foreign orders (except Canada) add 20% P & H. Orders over \$50 add 85¢ for insurance.

the answers from such a short program to be thought-provoking. The program generates ideas, which is a form of creativity. But is it creativity from the machine that arranges the word symbols, or from the man who interprets those symbols? Or both? Is this machine-aided creation? The sentences generated by Chat are enigmatic, but that could be changed by programming some restrictions on word association. The meaningless sentences would be reduced by this and further suppressed by a supervisory censor. We could even program it to learn from human prose. But would we then be restricting creativity?

If you are already competent in AI, *Artificial Intelligence in BASIC* is not for you unless you would like to instruct others. It could be a useful text for a short laboratory course in which the existing programs could be extended as exercises, or it could serve as a practical supplement to more theoretical material. It is superb as an introductory text for study at home. The programs are short enough that you could enter most in less than half an hour.

The knowledge attained from these short BASIC programs is readily transportable to other, more efficient languages, where it can become a tool for construction of large, more practical AI programs.

*Norman J. Chaplin (3155 South Dr., Allentown, PA 18103) is a retired designer in VLSI now acting as a writer and consultant.*

## THE COGNITIVE COMPUTER

Reviewed by Darrow Kirkpatrick

Roger Schank, director of Yale University's Artificial Intelligence Project, has succeeded in writing a clear, exciting report on the nature of human intelligence and the implications of machine intelligence. Explaining his research, Schank tells us how much we must know about computers, what we can learn about intelligence from the development of understanding computers, and how intelligent computers will affect our world.

## SETTING THE RECORD STRAIGHT

Schank risks distilling his 20 years of research into one nontechnical book about artificial intelligence. This is his attempt to set the record straight. Along the way we can learn a little about how computers work and a great deal about how human beings think, learn, and understand. Schank thinks learning about AI research is more important for an understanding of computers than learning to program in BASIC (or any of the other computer-literacy skills in vogue). AI research has the potential to transform our lives through the creation of new machines that can do things never done before.

## COGNITIVE UNDERSTANDING

If we want to build understanding computers, first we must understand ourselves; we must be familiar with human

*(continued)*

ALL SALES SUBJECT TO THE TERMS OF OUR 90 DAY LIMITED WARRANTY. FREE COPY UPON REQUEST.

---

Amazing  
what goes  
into  
Macintosh  
these days.

---



# IBM PC software, for instance.

Macintosh and IBM PC software. Compatible at last, thanks to MacCharlie, a rather innovative coprocessing system.

And imagine the consequences.

Nearly 10,000 IBM PC software programs designed for general business and specific applications in real estate, insurance, law, medicine, banking, etcetera, can now join forces with Macintosh's own popular programs.

And, the myriad of IBM PC-compatible software adopts Macintosh's many beloved features, including desktop utilities such as the clipboard and the calculator.

In addition, MacCharlie allows

IBM PC and Macintosh data files to be exchanged. Talk about flexibility.

But the good news gets better.

You see, MacCharlie delivers hardware compatibility, as well. For example, IBM letter-quality printers can be easily used with Macintosh.

Furthermore, MacCharlie

now allows Macintosh to perform virtually any networking an IBM PC can perform. Even to the extent of tying in with IBM mainframes.

In other words, your networking capability goes beyond the Apple family.



The Macintosh keyboard slides right into MacCharlie's keyboard. About as easy as slipping a letter in an envelope.

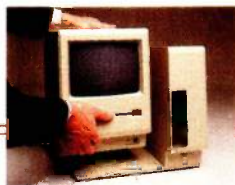

Macintosh sets snugly beside MacCharlie, on a custom-fit pedestal.



Once you plug in MacCharlie's power and keyboard cords, you're ready to enjoy a very happy marriage.



How does it happen? As easily as slipping on penny loafers.

In mere moments, MacCharlie combines the best features of the world's premier personal computers.

And despite the fact that it

turns one computer into two, MacCharlie adds but a handful of square inches to Macintosh's physique.

In short, one of life's most perplexing decisions—whether to buy a Macintosh or an IBM PC—

can now be made with the greatest of ease.

Ask for MacCharlie at your local computer store. Or, for more information, call toll-free, 1-800-531-0600. (In Utah, call 801-531-0600).

MacCharlie offers 256K RAM, with optional upgrade to 640K RAM; 360KB disk drive, and optional second disk drive.

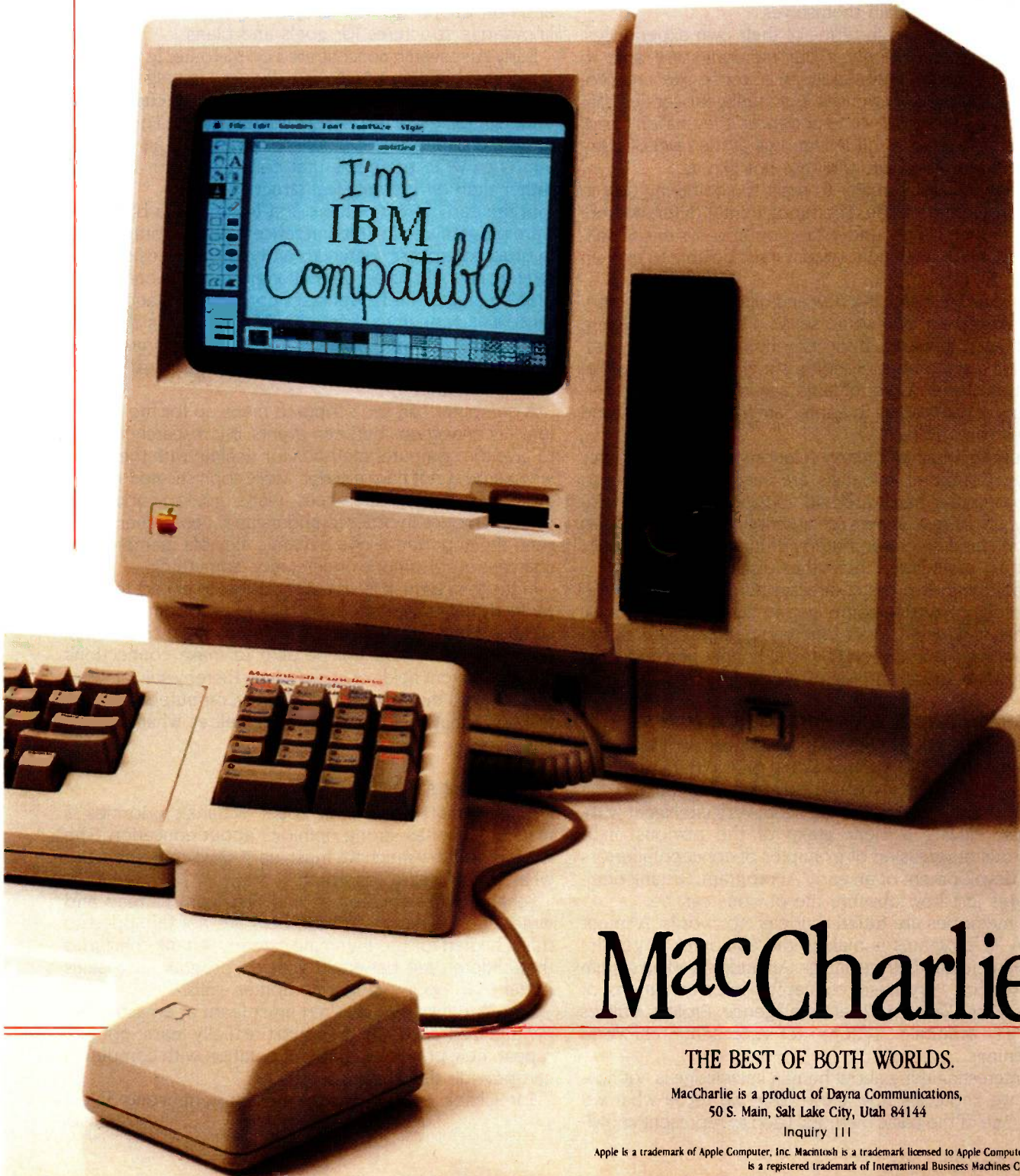

# MacCharlie™

THE BEST OF BOTH WORLDS.

MacCharlie is a product of Dayna Communications,  
50 S. Main, Salt Lake City, Utah 84144

Inquiry 111

Apple is a trademark of Apple Computer, Inc. Macintosh is a trademark licensed to Apple Computer, Inc. IBM is a registered trademark of International Business Machines Corporation.



thought processes before we can program an understanding computer. Schank defines three levels of understanding: making sense, cognitive understanding, and complete empathy. Current AI research is concerned mostly with cognitive understanding. Cognitive computers will be able to learn, relate the present to the past, formulate new information, and explain themselves.

People understand in terms of their own experiences. We can understand only if our memories are able to change to match a situation. In a sense, we are programmed by our experiences. But intelligent entities can, at best, "make sense" of experiences they haven't had. Computers will never understand us at the level of complete empathy because they are not like us.

Intelligence is the ability to react to something new in a nonprogrammed way. The fundamental difference between imitation and understanding in a system is self-knowledge. An intelligent system must be able to explain itself.

Because AI research is a new and different science, every major AI project is in some sense a failure at modeling human intelligence. Each success shows only what is missing. AI is a steady but plodding study of the impossible. As it asks questions about language, reading, and understanding, it can lead us to appreciate human qualities and abilities even more.

AI research has an uneasy relationship with computer science. Computer scientists are searching for ways to make computer hardware and software work more efficiently, but AI researchers are attempting to raise the level of understanding of computers. Ultimately, Schank feels, AI will be assimilated into other disciplines.

Schank defines product-directed AI as concerning the technology of getting computers to do intelligent things, and theory-directed AI as concerning the representation of knowledge, learning, and human thought processes. Expert systems are examples of product-directed AI.

### LANGUAGE AND KNOWLEDGE STRUCTURES

Until recently, the representation of abstract ideas and concrete events has been possible only with natural languages. Computers also must be able to handle abstract concepts, but a system will not seem very intelligent without also having a clear grasp of the obvious. In a humorous progression of examples of conceptual errors in the development of an early AI program, Schank demonstrates just how obscure the obvious can be.

Our memories are tuned to ideas, not words. A major task in AI programs is making the computer forget the words and retain their meanings. An understanding system must rely on very basic conceptual representations of events. The Yale Artificial Intelligence Project utilizes only 11 primitive actions to represent real-world happenings.

An interesting thing about human knowledge is not how much we know, it's how effortlessly we recall what we know. One of the basic methods used to represent knowl-

edge in AI programs is the "script." Scripts enable computers to deal with everyday, stereotypical situations by using a group of connected possibilities, or "slots," and rules for filling these slots.

But if computers are to understand more than stereotypical situations, they must have some knowledge of why and how people do what they do. Computers must have knowledge structures for goals and plans.

Early AI research concentrated on the outer form of language by building parsers to dissect language into its grammatical elements. Current research is occupied with understanding the *content* of communication. For Schank and others, language is a vehicle rather than an end; the aim is to write programs that concentrate on meaning rather than on grammatical structure.

In the early 1970s Schank and his students built software programs called the Inferencer and the Paraphraser. In order to process sentences and make conclusions, the Inferencer could parse, draw inferences, and generate natural language. The Paraphraser could understand a sentence well enough to restate it in different ways, from different perspectives. However, to understand large pieces of text, computers must draw inferences from many connected sentences.

A computer can use scripts to make up for the lack of logical connections between events, but researchers have to give the computer methods for dealing with the world when it does not have a script. More sophisticated AI programs use beliefs, inferences, plans, goals, scripts, and prior memories in order to understand. Researchers have seen the importance of a dynamic, flexible memory that changes every time it understands something.

In the long term, it is unrealistic for us to expect to build perfectly general knowledge structures into computers. Instead we must give them the ability to learn. This is the only way computers will be able to make connections across different fields of knowledge—thereby solving what Schank calls the "domain problem." Computers will have to know what they don't know as well as what they do know.

### AI IN EDUCATION

I suspect that first among Roger Schank's priorities is teaching. He has strong opinions about education. The issue is not how much we must learn *about* computers but what we can learn *from* them.

Schank thinks children should first learn to read and write. Public schools and teachers are not equipped to train children for programming careers. Schank concludes that children are better off with no programming skills rather than poorly taught computer skills.

Schank thinks that children must learn at an active, individualized pace. Children must actually learn, not just repeat, new principles. Experimentation with computers can provide this kind of learning.

For Schank, education is the most important and poten-

(continued)

# Where **Giants** Fear To Tread



For five years NESTAR has ventured where giants have feared to tread—local area networking. In fact, NESTAR has installed more large local area networks in large institutions than any other manufacturer.

Soon the giants will be involved in networking and that will ensure broad industry support. NESTAR's products will be totally compatible and complementary to the systems sold by the giants. That way you receive the advanced technology and responsiveness of NESTAR today with the comfort that compatibility with giants brings.

Call or write for your copy of:  
"Executive Briefing"  
2585 East Bayshore Road,  
Palo Alto, CA 94303 • (415) 493-2223

**Local Area Networks  
For Large Organizations**

# NESTAR





7400

74F00

NEW

74ALS00

DISK CONTROLLERS

Table with columns: Part No., Pkts, Price. Lists various 7400 series components like inverters, NAND gates, and decoders.

Table with columns: Part No., Pkts, Price. Lists various 74F00 series components like NAND gates and multiplexers.

Table with columns: Part No., Pkts, Price. Lists various 74ALS00 series components like inverters and NAND gates.

Table with columns: Part No., Pkts, Price. Lists various 74ALS00 series components like NAND gates and multiplexers.

Digitalker™ DT1050 - Application: Teaching aids, interfaces, clocks, address, communications, language translators, etc.

DT1050 Digitalker™ Processor Chip... \$34.95 ea. DT1057 - Exports the DT1050 vocabulary from 12K to over 260K words, 2.0MB and specs.

MICROPROCESSOR COMPONENTS

New Super Low Prices! New Super Low Prices!

Table with columns: Part No., Pkts, Price. Lists microprocessor chips (8080, 8085, 8088, 8086) and dynamic RAMs (1103, 1104, 1105).

Table with columns: Part No., Pkts, Price. Lists various 74LS00 series components like inverters and NAND gates.

Table with columns: Part No., Pkts, Price. Lists various 74ALS00 series components like inverters and NAND gates.

Table with columns: Part No., Pkts, Price. Lists various 74ALS00 series components like NAND gates and multiplexers.

Table with columns: Part No., Pkts, Price. Lists various 74ALS00 series components like NAND gates and multiplexers.

74HC High Speed CMOS 74HC00 - 74HC138. Lists various CMOS logic components.

30009 1983 INTERSIL Data Book (1986 pg.) \$9.95. Lists various CMOS logic components like 74HC00, 74HC01, etc.

Table with columns: Part No., Pkts, Price. Lists various 74S00 series components like inverters and NAND gates.

Table with columns: Part No., Pkts, Price. Lists various 74ALS00 series components like inverters and NAND gates.

Table with columns: Part No., Pkts, Price. Lists various 74ALS00 series components like NAND gates and multiplexers.

Table with columns: Part No., Pkts, Price. Lists various 74ALS00 series components like NAND gates and multiplexers.

Table with columns: Part No., Pkts, Price. Lists various 74C00 series components like inverters and NAND gates.

Table with columns: Part No., Pkts, Price. Lists various CA-LINEAR components like op-amps and comparators.

Table with columns: Part No., Pkts, Price. Lists various CD-CMOS components like memory chips.

Table with columns: Part No., Pkts, Price. Lists various SPECIAL FUNCTION components like timers and converters.

Table with columns: Part No., Pkts, Price. Lists various DATA ACQUISITION components like ADCs and DACs.

Table with columns: Part No., Pkts, Price. Lists various 74C00-C/MOS components like inverters and NAND gates.

Table with columns: Part No., Pkts, Price. Lists various LINEAR components like op-amps and comparators.

MasterCard amecore ELECTRONICS VISA. 1355 SHOREWAY ROAD, BELMONT, CA 94002. 4/85 PHONE ORDERS WELCOME - (415) 592-8097 - Telex: 176043



## Commodore® Accessories

### RS232 ADAPTER FOR VIC-20 AND COMMODORE 64

**RS232 Interface**

The JE232CM allows connection of standard serial RS232 printers, modems, etc. to your VIC-20 and C-64. A 4-pole switch allows the inversion of the 4 control lines. Complete installation and operation instructions included.

Plugs into User Port • Provides Standard RS232 signal levels • Uses 6 signals (Transmit, Receive, Clear to Send, Request to Send, Data Terminal Ready, Data Set Ready).

**JE232CM \$39.95**

### VOICE SYNTHESIZER FOR APPLE AND COMMODORE

**Plug-In - Talking in Minutes!**

JE520CM

JE520AP

• Over 250 word vocabulary - affixes allow the formation of more than 500 words • Built-in amplifier, speaker, volume control, and audio jack • Recreates a clear, natural male voice • Plug-in user ready with documentation and sample software • Case size: 7 1/4" L x 3 3/4" W x 1-3/8" H

APPLICATIONS: • Security Warning • Telecommunication • Teaching • Handicap Aid • Instrumentation • Games

Part No.	Description	Price
JE520CM	For Commodore 64 & VIC-20	\$114.95
JE520AP	For Apple II, II+, and IIe	\$149.95

All Major Manufacturers Not Micron

### Computer Memory Expansion Kits

#### IBM PC, PC XT and Compatibles

Most of the popular Memory Boards (e.g. Quadram™ Expansion Boards) allow you to add an additional 64K, 128K, 192K or 256K. The IBM64K Kit will populate these boards in 64K byte increments. The kit is simple to install - just insert the 9 - 64K RAM chips in the provided sockets and set the 2 groups of switches. Complete conversion documentation included.

**IBM64K (Nine 200ns 64K RAMs)..... \$33.49**

#### IBM PC AT

Each kit comes complete with nine 128K dynamic RAMs and documentation for conversion.

**IBM128K (Nine 250ns 128K RAMs)..... \$199.95**

#### APPLE IIe

Extended 80-Column/64K RAM Card. Expands memory by 64K to give 128K when used with programs like VisiCalc™. Fully assembled and tested.

**JE864..... \$99.95**

#### TRS-80 MODEL I, III

Each Kit comes complete with eight MM5280 (UPD416/411) 16K Dynamic RAMs and documentation for conversion. Model I: 16K equipped with Expansion Interface can be expanded to 48K with 2 Kits. Model III: Can be expanded from 16K to 48K using 2 Kits. Each Kit will expand computer by 16K increments.

**TRS-16K3 200ns (Model III)..... \$6.29**  
**TRS-16K4 250ns (Model I)..... \$5.49**

#### TRS-80 MODEL IV & 4P

Easy to install Kit comes complete with 8 ea. 4164N-20 (200ns) 64K Dynamic RAMs and conversion documentation. Converts TRS-80 Model IV computers from 16K to 64K. Also expands Model 4P from 64K to 128K.

**TRS-64K-2..... \$29.95**

(Converts the Model IV from 16K to 64K or will expand the Model 4P from 64K to 128K)

**TRS-64K2PAL (Model IV only)..... \$49.95**

(8 - 4164's with PAL Chip to expand from 64K to 128K)

#### TRS-80 COLOR AND COLOR II

Easy to install Kit comes complete with 8 ea. 4164N-20 (200ns) 64K Dynamic RAMs and documentation for conversion. Converts TRS-80 Color Computers with D, E, ET, F and NC circuit boards to 32K. Also converts TRS-80 Color Computer II to 64K. Flex DOS or OS-9 required to utilize full 64K RAM on all computers.

**TRS-64K-2..... \$29.95**

#### INDUSTRIES

### PROTECT YOURSELF... DATASHIELD® Surge Protector

Eliminates voltage spikes and EMI/RFI noise before it can damage your equipment or cause data loss. 6-mo. warranty. Power dissipation (100 microsecond): 2,000,000 watts

Model 100

PART NO.	DESCRIPTION	PRICE
MODEL 75	4 Sockets, On/Off Switch.....	\$49.95
MODEL 85	6 Sock. Super Filters, On/Off Switch.....	\$59.95
MODEL 100	6 Sock. Super Filters, Low Volt. Alarm.....	\$69.95
MODEL 110AMS	5 Sockets, Super Filters.....	\$69.95
	Auto. Master Switch.....	\$99.95

### DATASHIELD® Back-Up Power Source

Protect your computer from blackouts, brown-outs, power surges and line noise. P11's PC200 is designed for PCs with floppy disk memory, the XT300 for hard disk memory and the AT300 for multi-user systems. A typical compatible PC for each of these standbys will be supported for 15 to 25 minutes after power is lost. Weight (PC200: 24 lbs.) - (XT300: 37.5 lbs.) - (AT300: 63 lbs.) - (AT300: 63 lbs.)

**PC200 (200 Watt Rating)..... \$299.95**  
**XT300 (300 Watt Rating)..... \$399.95**  
**AT300 (500 Watt Rating)..... \$699.95**  
**AT800 (800 Watt Rating)..... \$799.95**

## ProModem 1200 and Options



### Intelligent 300/1200 Baud Telephone Modem with Real Time Clock/Calendar

The ProModem™ is a Bell 212A (300/1200 baud) intelligent stand-alone modem. Full featured expandable modem. Standard features include Auto Answer and Auto Dial, Help Commands, Programmable Intelligent Dialing, Touch Tone™ and Pulse Dialing & More. Hayes command set compatible plus an additional extended command set. Shown w/ alphanumeric display option.

Part No.	Description	Price
PM1200	RS-232 Stand Alone Unit.....	\$349.95
PM1200A	Apple II, II+ and IIe Internal Unit.....	\$369.95
PM1200B	IBM PC and Compatible Internal Unit.....	\$269.95
PM1200BS	IBM PC & Comp. Int. Unit w/ProCom Software.....	\$319.95
MAC PAC	Macintosh Package.....	\$399.95

(Includes PM1200, Cable, & ProCom Software)

### OPTIONS FOR ProModem 1200

PM-COM	(ProCom Communication Software).....	\$79.95
	Please specify Operating System.....	
PM-OP	(Options Processor).....	\$79.95
PMO-16K	(Options Processor Memory - 16K).....	\$10.95
PMO-32K	(Options Processor Memory - 32K).....	\$20.95
PMO-64K	(Options Processor Memory - 64K).....	\$39.95
PM-ALP	(Alphanumeric Display).....	\$79.95

**PM-Special (Includes Options Processor, 64K Memory and Alphanumeric Display)..... \$189.95**

## KEYBOARDS



13 1/8" L x 4 1/4" W x 1 1/4" H

#### Mitsumi 54-Key Unencoded All-Purpose Keyboard

• SPST keyswitches • 20 pin ribbon cable connector • Low profile keys • Fast keys: cursor controls, control, caps (lock), function, enter and shift keys • Color (keycaps): grey • Wt. 1 lb. • Pinout included

**KB54..... \$14.95**

New!



#### 82-Key ASCII Cherry Keyboard

• 7-bit parallel ASCII • 11-key numeric keypad • Cursor keypad • SPST mechanical keyswitches • 4 illuminated keys • 26-pin header connector • Color: white • Size: 16" L x 6 1/2" W x 1 1/4" H • Spec included

**KB8201..... (1700 avail.)..... \$29.95**

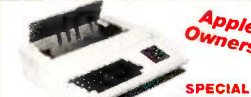

Apple Owners!

SPECIAL FUNCTIONS!

#### Apple Keyboard and Case for Apple II and II+

Keyboard: 68 keys • 15-key keypad • Direct connection with 16-pin ribbon connector • 26 special functions • Size: 14 1/2" L x 5 1/2" W x 1 1/2" H

Case: Accommodates KB-A68 • Pop-up lid for easy access • Fits power supply and motherboard too • Size: 15 1/2" L x 18 D x 4 1/4" H

Part No.	Description	Price
KB-EA1	Apple Keyboard and Case (pictured above).....	\$134.95
KB-A68	68-Key Apple Keyboard only.....	\$ 79.95
EAEC-1	Expanded Apple Enclosure Case only.....	\$ 59.95

## POWER SUPPLIES



#### Power/Mate Corp. REGULATED POWER SUPPLY

• Input: 105-125/210-250 VAC at 47-63 Hz • Line regulation: ±0.05% • Three mounting surfaces • Overvoltage protection • UL recognized • CSA certified

Part No.	Output	Size	Weight	Price
EMAS/6B	5V@3A/6V@2.5A	4 1/4" L x 4" W x 2 1/4" H	2 lbs.	\$29.95
EMAS/6C	5V@6A/6V@5A	5 1/4" L x 4 1/4" W x 2 1/4" H	4 lbs.	\$39.95



#### KEPCO/TK 4-OUTPUT SWITCHING POWER SUPPLY

• Ideal for disk drive needs of CRT terminals, microcomputers and video games • Input: 115/230VAC, 50/60Hz • Output: 5V @ 5 Amp, +12V @ 1.8 Amp, +12V @ 2 Amp, -12V @ 0.5 Amp • UL recognized • CSA certified • Size: 7 1/2" L x 6 3/16" W x 1 1/4" H • Weight: 2 lbs.

**\$59.95 each or \$99.95**

**MRM 174KF..... 2 for \$99.95**



#### Switching Power Supply for APPLE II, II+ & IIe™

• Can drive four floppy disk drives and up to eight expansion cards • Short circuit and overload protection • Fits inside Apple computer • Fully regulated +5V @ 5A, +12V @ 1.5A, -5V @ 5A, -12V @ 5A • Direct plug-in power cord included • Size: 9 1/2" L x 3 1/2" W x 2 1/4" H • Weight: 2 lbs.

**KHP4007 (SPS-109)..... \$59.95**



#### 4-CHANNEL SWITCHING POWER SUPPLY

• Microprocessor mini-computer, terminal, medical equipment and process control applications • Input: 90-130VAC, 47-440Hz • Output: +5VDC @ 5A, -5VDC @ 1A, +12VDC @ 1A, -12VDC @ 1A • Line regulations: ±0.2% • Ripple: 30mV p-p • Load regulation: ±1% • Overcurrent protection • Adj. 5V main output • 10% • Size: 6 1/2" L x 1 1/2" W x 4-1/5/16" H • Weight: 1 1/2 lbs.

**FCS-604A..... \$69.95**



#### IBM PCXT EQUIVALENT 130 WATT POWER SUPPLY

• Upgrade your PC! • Input: 100V-130V/200V-260V selectable @ 47 to 63Hz • Output: +5VDC @ 15A, -5VDC @ 0.5A, +12VDC @ 4.2A, -12VDC @ 0.5A • Plug compatible connectors • Fits into IBM PC • Weight: 6 lbs.

**IBM-PS..... \$169.95**

\$10.00 Minimum Order - U.S. Funds Only  
 California Residents Add 6 1/2% Sales Tax  
 Shipping - Add 5% plus \$1.50 Insurance  
 Send S.A.S.E. for Monthly Sales Flyer!

Spec Sheets - 30¢ each  
 Send \$1.00 Postage for your  
 FREE 1985 JAMECO CATALOG  
 Prices Subject to Change



1355 SHOREWAY ROAD, BELMONT, CA 94002

4/85 PHONE ORDERS WELCOME - (415) 592-8097 Telex: 176043

## Apple® Accessories

### 5 1/4" APPLE™ Direct Plug-In Compatible Disk Drive and Controller Card

The ADD-514 Disk Drive uses Shugart SA390 modules - 143K formatted storage - 35 tracks - Compatible with Apple Controller & ACC-1 Controller. The drive comes complete with connector and cable - just plug into your disk controller card • Size: 6" L x 3 1/2" W x 8-9/16" D • Weight: 4 1/2 lbs.

**ADD-514 (Disk Drive)..... \$169.95**  
**ACC-1 (Controller Card)..... \$ 49.95**

### More Apple Compatible Add-Ons...

APP-1	(Cooling Fan with surge protection).....	\$39.95
KHP4007	(Switching Power Supply).....	\$59.95
JE614	(Numeric/Aux. Keypad for IIe).....	\$59.95
KB-A68	(Keyboard w/Keypad for II & II+).....	\$79.95
MON-12G	(12" Green Monitor w/safe stand).....	\$99.95
JE864	(80 Col. +64K RAM for IIe).....	\$99.95
ADD-12	(5 1/4" Half-Height Disk Drive).....	\$179.95

NEW!

### ADDITIONAL APPLE™ ADD-ONS AVAILABLE

ARC-16K	(16K RAM Card for Apple II & II+).....	\$39.95
AEB-2	(EPROM Burner for Apple II, II+ & IIe).....	\$69.95
	Allows copy of standard EPROMs 2708, 2716, 2732, 6264	
ASSC-P	(Super Serial Card for Apple II, II+ & IIe).....	\$99.95
ADD-IIc	(5 1/4" Half-Ht. Disk Drive for Apple IIc).....	\$189.95

## DISK DRIVES



Documentation Included

MP151S	(MPI 5 1/4" SS full-ht.).....	\$ 89.95
RFD480	(Remex 5 1/4" DS full-ht.).....	\$109.95
TM100-2	(Tandon 5 1/4" DS full-ht.).....	\$159.95
FD55B	(Teac 5 1/4" DS half-ht.).....	\$149.95
SA455	(Shugart 5 1/4" DS half-ht.).....	\$159.95
FDD100-8	(Siemens 8" SS full-ht.).....	\$119.95
PKC-5	(5 1/4" Power Cable Kit).....	\$2.95
PKC-8	(8" Power Cable Kit).....	\$3.95

## UV-EPROM Eraser

8 Chips - 21 Minutes	
1 Chip - 15 Minutes	

Erases all EPROMs. Erases up to 8 chips within 21 minutes (1 chip in 15 minutes). Maintains constant exposure distance of one inch. Special conductive foam liner eliminates static build-up. Built-in safety lock to prevent UV exposure. Compact - only 9 00" L x 3 70" W x 2 60" H. Complete with holding tray for 8 chips.

**DE-4 UV-EPROM Eraser..... \$74.95**

**UVS-11EL Replacement Bulb..... \$16.95**

### JE664 EPROM PROGRAMMER

See Our New IBM Communications Program! 24 & 28 PIN PACKAGES

8K to 64K EPROMs



REQUIRES NO ADDITIONAL SYSTEMS FOR OPERATION  
 Programs and validates EPROMs • Checks for properly erased EPROMs • Emulates PROMs or EPROMs • Loads data in RAM by keyboard • Changes data in RAM by keyboard • Loads RAM from an EPROM • 64K RAMs can be used for external microprocessor development • Compares EPROMs for content differences • EPROM Programmer • Input: 115VAC @ 60Hz • Assembled and tested • Size: 15 1/2" L x 5 1/2" W x 3 1/2" H • Wt. 2 1/2 lbs. • 2716 Module included

**JE664-ARS EPROM Programmer..... \$995.00**

**JE665-RS232C INTERFACE OPTION** - This option implements computer access to the JE664's RAM, allowing computer to manipulate, store and transfer EPROM data to and from the JE664. Sample program listing is supplied in MIBASIC for CP/M computers. Documentation provided to adapt the software to both formats. Program is ideal for keeping archives of master EPROMs on disk. The program is compatible for all EPROMs listed with the JE664. Computer requirements: IBM-PC, XT (or eq.) with at least 128K RAM and one serial port. Optional: One parallel port for printer.

**JE664-ARS-CP..... \$1195.00**

**JE664-ARS COMMUNICATION PROGRAM FOR IBM-PC or XT and Compatibles**

• Fast compiled BASIC program • Easy to use, menu-driven • Print hard copies of EPROM data • View data in HEX and ASCII

**NEW!**

The JE664-ARS Communication Program was written for quick interfacing between the JE664-ARS EPROM Programmer and the IBM-PC computer and compatibles. Menu-driven program allows user to Load and Save EPROM data to and from the computer or floppy disk. Data entered by the computer can be viewed in Hex & ASCII formats. Printed hard-copies are also displayed in both formats. Program is ideal for keeping archives of master EPROMs on disk. The program is compatible for all EPROMs listed with the JE664. Computer requirements: IBM-PC, XT (or eq.) with at least 128K RAM and one serial port. Optional: One parallel port for printer.

**JE664-ARS-CP..... \$49.95**

**JE664-ARS Communications Program (5 1/4" Disk and User's Instructions)**

**JE664-CP CABLE..... \$29.95**

Cable for IBM-PC to JE664-ARS Program (5 Shielded Cable & Connectors)

**JUMPER (Personality) MODULES** - Jumper (Personality) Modules for 8K, 16K, 32K, and 64K EPROMs. Please specify EPROM and manufacturer.

**JUMPER (Personality) MODULE..... \$14.95 each**



**FRIENDLY SERVICE AT A FRIENDLY PRICE**  
**Friendly Computer Center, Inc.**  
 1381 Coney Island Avenue, Brooklyn, New York 11230

Must Have It Immediately! Ask For GREEN LIGHT SERVICE For Same Day Shipment!

<p><b>FRIENDLY COMPUTER</b> Satisfaction Guarantee 14 days return shipping refunded in original MINY CONDITION with all options (ask shipped)</p> <p><b>C.I.TOH PROWRITER</b> ALL AVAILABLE w/I.B.M. ROM</p> <p>7500 105 C.P.S. 219.00                  8510 120 C.P.S. 289.00                  1550 120 C.P.S. 15" 449.00                  8600 180 C.P.S. 569.00</p> <p><b>STARWRITER</b> F-10-40P 849.00 A-10-20 479.00</p> <p><b>IBM</b></p> <p>IBM® HARD DISK SYSTEM                  IBM® PC 256K                  10 MEG W/1 DS FLOPPY                  IBM MONO CARD &amp; MONITOR  <b>\$3249 complete</b></p> <p><b>DISK DRIVES-FOR IBM</b> Teac 10.5 ht. DS/DO 149 Rana 2000 IBM 149</p> <p><b>ADD ON BOARDS</b> FOR IBM</p> <p>AST Six Pack Plus 64K 249.00                  Quadram Expanded Quadboard w/64K 259.00                  Hercules Graphics Board 319.00                  Hercules Color Card w/Parallel Port 179.00                  Koala Speed Key System 149.00                  Mouse Systems Mouse w/Mouse w/P.C. Paint and Menu 159.00                  Hayden Saragon III Chess 34.90                  Microsoft Flight Simulator II 137.90                  Hayden Saragon III for Mac 39.90                  De Base III 349.00                  Framework 379.00                  SYMPHONY CALL                  Star Accounting Partner 2 749.00                  Wordstar 2000 249.00</p>	<p><b>PRINTERS SPECIAL!</b></p> <p><b>OKIDATA</b> Microline 84-200 C.P.S. 669.00 Microline 82-120 C.P.S. 225.00 Microline 92 359.00 Microline 92 w/Mac Compatible 459.00 Microline 93 589.00</p> <p><b>TOSHIBA</b> New Toshiba-1340 699.00 Toshiba-1351 1249.00</p> <p><b>Juki</b> Juki-6100 379.00 Juki-6300 call Juki Tractor 6100 109.00</p> <p>New Gemin SG Series Call</p> <p><b>SUPER SPECIALS!</b></p> <p><b>Peripherals by Apple</b>                  Apple Drive IIc \$289                  Apple IIc Mouse with paint \$99                  Apple IIe Mouse with paint \$139                  Apple 1200/300 Baud Modem \$389                  APPLEWORKS for IIc or IIc \$219  <b>Apple IIe Professional System</b>                  • Apple IIe 128K Computer                  • Apple Dual Disk Drive w/controller card                  • Apple Extended 80 column Display Card                  • Apple Monitor II - 12" tilt/green                  • Pro-Dos Operating System  <b>Special \$1439</b></p> <p>Apple IIc with Monitor and Stand Mac-Mania Special \$975.00                  Macintosh 512K with Imagerwriter Special \$2649</p> <p><b>MONITORS</b> Princeton HK-12 Graphics 459.00 New Amdek Color 300 269.00 Amdek 310A 175.00</p> <p><b>TAXAN</b> T115 12" Green 119.00 T116 12" Amber 129.00 T127 12" Green I.B.M. 149.00 T122 12" Amber I.B.M. 159.00 210 R.G.B. Color 259.00</p> <p><b>MODEMS</b> Hayes 1200B IBM 379.00 Hayes 1200 RS232 459.00 Hayes 300 RS232 195.00 Micromodem IIe 235.00 HAYES 300 - for IIc 239.00 New Hayes 2400 CALL</p> <p><b>PRENTICE POPCOM</b> 1200 External 349.00 1200 Internal 329.00 Compuerve Starter Kit 28.95 The Source Starter Kit CALL Grappier Buffer Plus 16K w/cable 149.00</p> <p><b>LETTER QUALITY PRINTERS</b> ONE TIME SPECIAL - LIMITED QUANTITY C.I.TOH - Leading Edge 25 cps 15" Daisy Wheel \$449 1 YEAR WARRANTY C.I.TOH Tractor 129.00</p>
---	--

**HIGH QUALITY SET OF 64K (9 chips) only \$29.90 Min 6 sets**

FOR MAIL ORDERS: Send Money Order, Certified Check, Mastercard, VISA gladly accepted. Add estimated price for shipping, handling and insurance. WE WILL SHIP ORDERS AT THE ADVERTISED PRICES GUARANTEED UNTIL APRIL 30 '85. Apple is a registered trademark of Apple Computer, Inc. IBM is a registered trademark of International Business Machines.

**TO ORDER CALL (800) 258-5805** FOR INFORMATION CALL **(718) 252-9737**

**Friendly Computer Center, Inc.**  
1381 Coney Island Avenue Brooklyn, New York 11230

BOOK REVIEWS

tially beneficial application of computers. Schools should be paying attention to computers not because they will take over our lives or because everyone has to be a programmer but because computers are part of the solution to education problems.

**THE FUTURE**

Computers will be really useful to the average person only when they can be used with no training at all. Schank sees advisory systems in areas such as finance, medicine, and law becoming available within the next few years. Sophisticated learning systems, with cognitive abilities, will be available within a decade, Schank says. And within 50 years, he predicts, there will be integrated world-knowledge systems capable of learning about new domains; their most effective role will be as librarians and consultants, figuring out what we need to know about a subject and the right way to explain it to us.

AI may change the way we look at ourselves. One of its by-products will be the opportunity for an informed public. People lack the information they need because they don't want to appear stupid, bother an expert, or pay lots of money for advice. In the future, people will be able to obtain expert advice of all kinds, easily, quickly, and inexpensively from computers. Of course, we should evaluate computer advice as carefully as we would that from any other advisor with a stake in our decision.

**CRITICISM**

Schank is best, and worst, when hypothesizing. He has made a career out of playing mind games, and most of those he presents are fascinating. However, he occasionally slips into an overly optimistic view of computers and the future. He says that machines will take over the most unpleasant human jobs and will provide people with the information they need to run their daily lives. I think this will be more a function of what people seek rather than simply what computers can provide.

**AUDIENCE**

*The Cognitive Computer* is not for those people who are interested in the engineering behind AI programs. Schank does not include details on how AI programs go together, what languages they are written in, and what kinds of hardware they run on. His contribution is to put thinking computers in perspective and show us where we can go with them.

It is a credit to his science of understanding how humans understand that Schank writes with such clarity. He demonstrates a genuine concern for how computers and their AI software will affect human lives. Schank has a healthy perspective on scientific progress: he doesn't believe that every aspect of human thought can or should be modeled on computers. ■

Darrow Kirkpatrick is an applications engineer at Development Associates Controls (POB 1049, Carpinteria, CA 93013).

**COMPARE AND SAVE**

**Sp COMPUTERS INC.**  
COMPARE AND SAVE

**WE SHIP OVERSEAS**  
**TEL: (415) 340-1006**  
 851 Burlway Road No. 303  
 Burlingame, CA 94010  
 U.S.A. Telex: 470477 Mons

<p><b>WORD PROCESSING</b></p> <p>Word Star 2000 \$264                  Wordperfect 4.0 252                  Volkswriter Deluxe 169                  PFS: Graph 84                  PFS: Write 84                  Easywriter II 195</p> <p><b>DATA BASE MANAGEMENT</b></p> <p>Knowledgeman 275                  dBase II 286                  dBase III 369                  Friday 179                  Pfs: File report pk 162                  R:Base 4000 295                  Quikcode II 155                  Infostar 282</p> <p><b>SPREADSHEETS</b></p> <p>Framework 369                  Multiplan 124                  Supercalc 3 199                  Visicalc IV 172                  Thinktank 109                  Calstar 87                  TK Solver 269</p>	<p><b>ACCOUNTING</b></p> <p>IUS - GL/AP/AR ea \$295                  Peachpak 4 249                  Open Sys. ea 399                  State of Art ea 399                  BPI - AR/AP/GL ea 395                  Great Plains Software ea 479</p> <p><b>HOME &amp; RECREATION</b></p> <p>The Print Shop 34.99                  Bankstreet Writ. 49.99                  Dollars &amp; Sense 64.99                  Fit Simulator 35.00                  Facemaker 23.99                  MindProber 36.99                  Mastertype 29.99                  Zargon II 16.99</p> <p style="text-align: center;"><b>SPECIALS</b></p> <p>Sidekick (pro) 37.99                  Sidekick (unpro) 54.99                  Turbo Pak: 74.99                  Pascal-Tutor-Toolbox                  Taxadvantage 49.99                  64K/9 chips 25.99                  Paperback Writer 29.99                  Executive Writer 54.99</p>
---	---

Payment: Mastercard, Visa, COD, Money Order or Check. Purchase Orders welcomed from qualified institutions. Prices subject to change. No surcharge for Visa/Mastercard. Shipping UPS surface per item \$4.00 within USA. Calif. Residents add sales tax.

**COMPARE AND SAVE**

# You can buy a less expensive diskette and not save a thing.

One can understand the temptation to buy a less expensive diskette.

Rather than a Dysan® diskette.

After all, the less expensive diskette is probably almost as good. And should you run into a bad one, well, it didn't cost that much, anyway.

Right? Not quite.

You see, a less expensive diskette is by definition less diskette. And the few pennies you save are worth a great deal less than what you have to lose.

Namely, your data.

That's why it makes more sense to spend a bit more for a Dysan diskette.

Every Dysan diskette you buy will record and retain all your data all the time.

You can be sure of that because every Dysan diskette is certified 100 percent error free and backed by our lifetime warranty.\*

So next time you're tempted to buy a less expensive diskette, ask yourself this question.

Can you really afford it?

For the name of the Dysan dealer nearest you, call toll free (800) 551-9000.

Dysan Corporation, 5201 Patrick Henry Drive, P.O. Box 58053, Santa Clara, CA 95050.

## Dysan®

Inquiry 131

Somebody has to be better than everybody else.

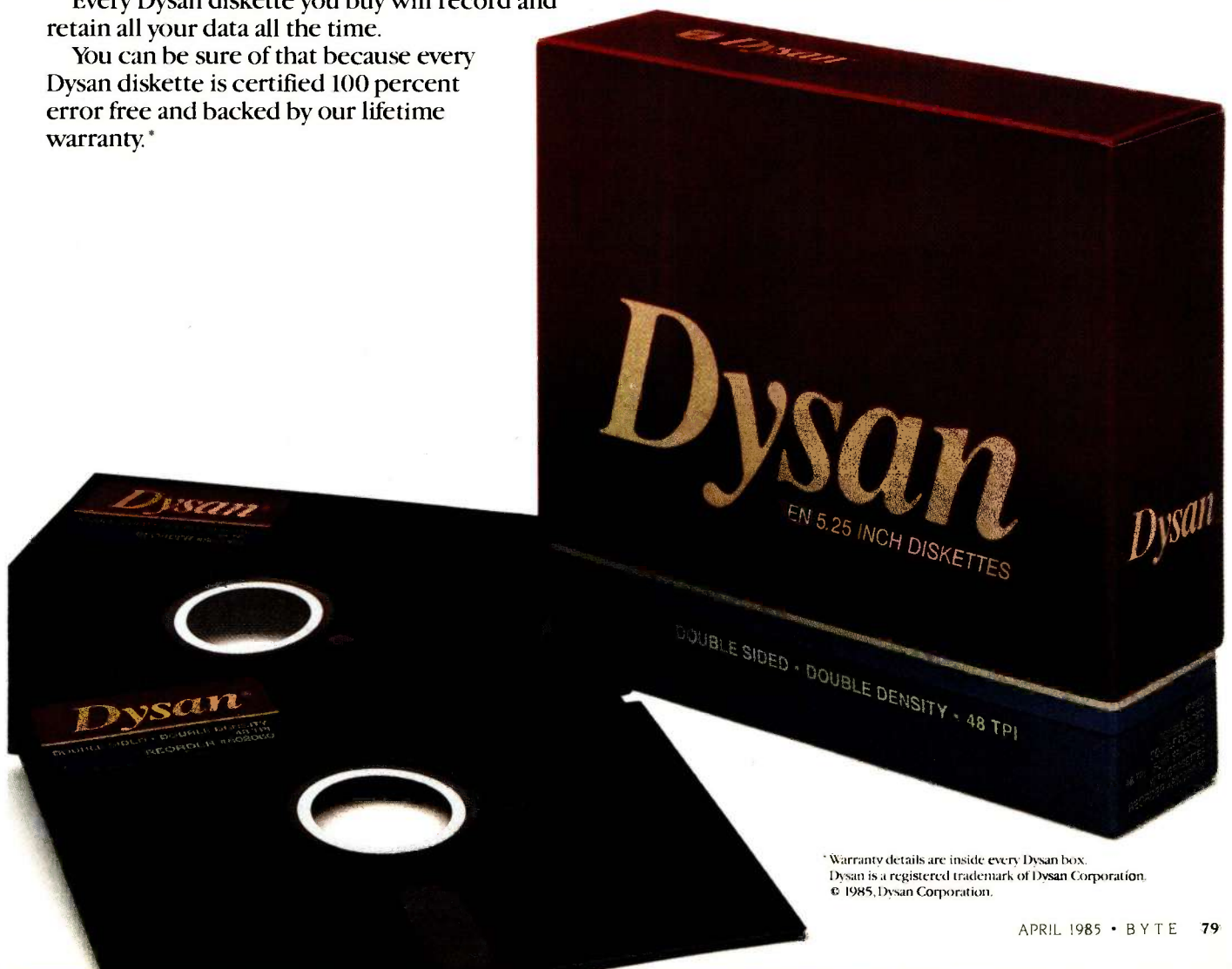

\*Warranty details are inside every Dysan box.  
Dysan is a registered trademark of Dysan Corporation.  
© 1985, Dysan Corporation.



*Give people the tools they need,  
and there is no limit to what they achieve.*

*Announcing the first major  
breakthrough in word processing  
technology since WordStar.*

*Now, state-of-the-art  
comes easy.*

Introducing WordStar 2000, a totally new word processing program from the makers of WordStar.

WordStar 2000 removes all limits from word processing. From what you can create. From what you can achieve.

Because WordStar 2000 lets you do everything.

Easily.

---

**From windows, to undo,  
to spelling correction, WordStar 2000  
does it all. And more.**

---

WordStar 2000 gives you the works. "Windows" allows you to work on different documents—simultaneously. "Undo" lets you replace text you mistakenly removed. A built-in spelling corrector checks and corrects misspellings from over 97% of the most commonly used words.

WordStar 2000 also has a "typewriter mode" to fill in forms or envelopes easily. Plus "format sheets," which give you ready-made

headings, tabs and margins at the touch of one key. It can even create and update footnotes.

---

**Finally, a truly integrated  
word processing system.**

---

WordStar 2000 goes well beyond words. It comes with a built-in five function math. A built-in mail merge enables you to mass produce form letters. Get our special Plus package and you also get a built-in mail list data base that allows you to create, update and sort your own mailing lists. Also a built-in indexer. Not to mention built-in telecommunications capabilities.

All integrated together, so you never have to leave the program.

---

**The only word processing program  
that interacts with you on your level,  
whatever your level.**

---

Before we created WordStar 2000, we studied the way people worked, and thought. We also drew from our experience with over 1,250,000 WordStar owners.



As a result, the keys you press are the keys you'd expect to press ("c" for copy, "p" for print, etc.). You may also use your computer's function keys. Menus have been uniquely designed for easy access to all functions. And MicroPro's exclusive "tutor-in-your-computer"™ makes learning fast and fun.

WordStar 2000 is the easy word processing program you'll never outgrow. Of course, the original WordStar and WordStar for PCjr will continue to provide substantial and proven word processing capability for those with more modest budgets.

See your local MicroPro dealer today or call (800) 227-6703 [in CA (800) 632-7979] for the dealer nearest you.

So you can remove all limits from what you can achieve.

*Now available for IBM PC®/AT®/XT® and compatibles with 256K RAM. Upgrade from WordStar to WordStar 2000 through your dealer, or call MicroPro Customer Update (800) 227-5609, 9am-3pm P.S.T.*

**WORDSTAR®**  
**2000**

*Now there are no limits.™* **MicroPro.**



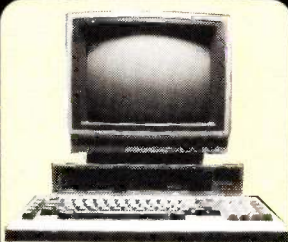

## A Custom System For Less Than a Clone

The Silver Fox™ will run most of the best-selling programs for the IBM-PC like the PFS series, Wordstar Multiplan, dBASE II, Flight Simulator, and Lotus 1 2 3.

But the basic Silver Fox gives you more hardware than other 8088 systems including 256K of RAM, 4 video outputs, a 12" high-resolution monitor, a full 25x80 display, and a superior keyboard with a big return key.

Also included as standard equipment is the best free software bundle in the business including:

MS-DOS 2.11	HAGEN-DOS
Color BASIC	GW BASIC
Wordstar 3.3	Easy Writer
Spell	Mail Track
FILEBASE	PC File III
CalcStar	Games, Graphics
PD Disk	OS Tutor

But the big feature the IBM-PC and its clones can't match is the Silver Fox 1.6 megabytes of storage. Even though the Silver Fox drives can store more than twice as much information, they can also read and write to standard 160K, 320K, and 360K formats.

Because the Silver Fox is born on a totally automated line in Japan, it is simply more reliable than PC's that are assembled by hand. So we back each Silver Fox with a limited one year warranty.

If you didn't think your

**\$1397**

would buy you this much computer simply dial

**1-800-FORAFox**

and leave your name and address at the beep. We'll rush you our Silver Fox catalog that will tell you how it can.

### PRINTERS

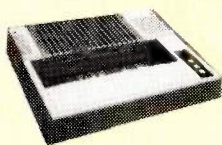

Epson FX-80+	<del>\$\$\$</del> \$180 off
Epson RX-80FT	<del>\$\$\$</del> \$100 off
Tally Spirit 80	\$254
Okidata 92	\$125 off
Okidata 93	\$210 off
Okidata 84	Call
Star SG-10	\$229
Star SR-15	\$599
Dataproducts 8050 "loaded"	\$1344
Tally 160L	\$589
Panasonic 1091	\$298
Toshiba 1340	\$695
Toshiba 1351	\$1198

### LETTER QUALITY

Powertype	\$299
Juki 6100	\$389
Juki 6300	\$719
Silver Reed 400	\$249
Silver Reed 500	\$299
Silver Reed 550	\$409
Silver Reed 770	\$724
NEC's	Call
Daisywriter 2000	\$824
Diablo 620	\$715
Diablo 630 API	\$1499

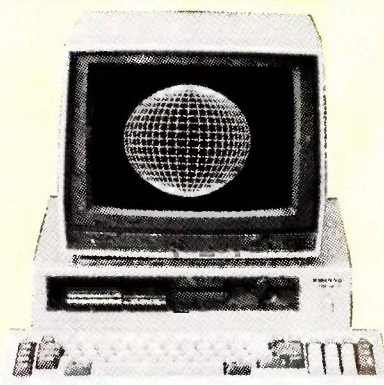

### \* More Free Software \*

Along with all the free great software you get with a Sanyo MBC 550, Scottsdale Systems includes 3 extra disks with: (1) OS Tutor. Teaches you everything you need to know about the operating system right on your system. (2) 15 games for the Sanyo 550 - a \$29 (retail) value. (3) Datemate - an appointment keeper with a perpetual calendar. (4) IS Manager. Allows you to change the structure of existing InfoStar files. (5) PC File. (6) 10 public domain games. (7) diagnostics and utilities, and (8) Sketch - A graphics/drawing program written in Sanyo Color Graphics BASIC.



## Columbia's

If you're looking for maximum compatibility, minimum prices, and nationwide service, you should consider buying a Columbia from Scottsdale Systems. Each system comes with a huge software bundle including MS-DOS 2.1, Basic, Perfect Writer, Perfect Calc, Perfect Filer, Perfect Speller, Fast Graphs, Home Accountant, Plus, Space Commanders, All Tutorials, and T.I.M. IV. We have the lowest prices on all Columbia computers including the new 4220 desktop with 256K, 2220 portable with a built-in 9" monitor. Your choice:

**\$1698**

### Altos Systems... big discounts, local installation



## Scottsdale Systems Ltd.

617 N. Scottsdale Road, Suite B, Scottsdale, Arizona 85257



**(602) 941-5856**



Call 8-5 Mon.-Fri.



We participate in arbitration for business and customers through the Better Business Bureau of Maricopa County.

### SINCE 1980

TELEMARKETING ONLY: If you plan to visit please call first for an appointment. Prices listed are for cash and include a 3% discount. We sell on a Net 30 basis to Fortune 1200 companies and universities. No C.O.D.'s or A.P.O.'s. P.O.'s add 2%. Visa, Mastercard add 3%. Az. residents add 6%. Prices subject to change, product subject to availability. Personal/company checks take 3 weeks to clear. All items listed are new with manufacturer's warranty, 0-20% restocking fee for returned merchandise. Shipping extra-products are F.O.B. point of shipment. Software is not warranted for suitability. Registered trademarks: Televideo-Televideo Systems, Inc., Silver Fox™, HAGEN-DOS-Scottsdale Systems, Ltd., Commuter-Visual Computer Incorporated.

## WYSE

50's	\$499
75's	\$575



## Houstin Instruments

DMP-29	\$1795
DMP-40	\$745
DMP-41	\$2340
other models	call

## Sanyo 555-2's

If you plan to purchase a Sanyo MBC 555-2 or a single drive MBC 550-2 you've made an excellent choice. The Sanyo MBC 550 series is the lowest priced 8088, MS-DOS system bar none. Plus with the single drive 550-2 systems you receive MS-DOS 2.11, Sanyo Color Graphics BASIC, Wordstar 3.3, CalcStar, and Easy Writer I.

With the 555-2 systems you also receive your choice of DataStar, ReportStar, SpellStar, and MailMerge, or Easy Writer II, Easy Mailer, Easy Planner, and Easy Filer.

We have sold more Sanyo microcomputers than any other dealer in the United States. Our prices have also been the lowest or among the lowest in the country and are presently too low to advertise.

But we wouldn't have become the largest Sanyo dealer in the country if all we offered was low prices. We include more free software than other dealers, we can install boards or extra memory for a modest charge, and we stock reference manuals for our customers.

Our sales staff knows the Sanyo system because they use Sanyo computers themselves, and unlike others who sell the Sanyo system we're an authorized Sanyo service center with techs on staff. If you plan to buy a Sanyo give us a call, we'll offer you a great price and a great deal more.

## While they last complete systems Sanyo 1100's

Our lowest price ever on a complete dual drive system. Each 280 based Sanyo 1100 system includes built-in 320K (formatted) disk drives, a cooling fan, a built-in 12" 25x80 green phosphor monitor, a parallel port and a serial port, and a great keyboard with 15 special function keys (enabled under both WordStar and BASIC) and a built-in palm rest.

Plus each system comes with CP/M, Sanyo BASIC and a complete MicroPro series of software including Wordstar 3.3, MailMerge, SpellStar, DataStar, ReportStar, and CalcStar. We pretest each system, and they're backed by over 75 service centers nationwide.

As someone who wrote us put it: "My local dealer says you couldn't possibly sell this whole package for \$888 because he sells the WordStar alone for \$495."

Well the local dealer is partially correct because while they last we're selling the whole package for:



**\$848**

### OLYMPIA NP



## IS IT SICK TO LOVE A PRINTER?

If you love your Okidata 92 or Epson FX-80 don't read any further because the new Olympia NP is rated as faster, is noticeably quieter, and has a near letter quality mode that is much superior to anything in its price class.

Plus unlike the Okidata or the Epson the Olympia comes with adjustable tractor feed (as well as friction feed) as standard equipment. The tractor feed is the "push-type" and the NP has a rear bar so that it works great with continuous forms.

The NP uses standard Epson type ribbons, comes with the quality that has made Olympia a world leader in typewriters and is backed by nationwide service.

To quote PC magazine: "The (NP) printer is a sure thing if it falls into your price range and even if it doesn't, it may be worth considering."

If you're considering the purchase of an Okidata, an Epson or even a Toshiba, give us a call and let us send you an actual print sample from the Olympia NP and additional information.

Because if you were to buy an Epson FX-80+ or an Okidata 92 with tractors at the lowest advertised price anywhere you would be paying about \$100 more for an inferior printer. Scottsdale Systems sells the Olympia NP with a 10' shielded cable for a mere:

**\$344**



# E·V·E·N·T· Q·U·E·U·E

## April 1985

### ● BUSINESS SHOW

Business-Expo, various sites throughout the U.S. This show features exhibits and services related to office technology. Contact International Business Expositions Inc., 200 East Northland Towers, 15565 Northland Dr., Southfield, MI 48075-5378, (313) 569-8280. *April-May*

### ● ROBOTICS, MATHEMATICS, COMPUTER

LECTURES—Robotics Lecture Series and Colloquium Series, Room W-117, Mathematics & Science Building, Montclair State College, Upper Montclair, NJ. Monthly lecture series featuring experts in computer science, mathematics, and robotics. Contact Gideon Nettler, Department of Mathematics and Computer Science, Montclair State College, Upper Montclair, NJ 07043, (201) 893-4294 or (201) 893-5132. *April-May*

### ● INTELLIGENT MACHINES

Machine-Intelligence Classes, Turing Institute, Glasgow, Scotland. Among the classes offered are "Foundations of Artificial Intelligence" and "Cognitive Modeling as a Basis for Expert Systems." Contact The Turing Institute, George House, 36 North Hanover St., Glasgow G1 2AD, Scotland; tel: 041-552-6400. *April-June*

### ● MEMORY CARDS

STUDIED—Memory-Card Technology, Columbus, OH. Business, industrial, and technological concerns will be addressed. Panel discussions and exhibits. The fee is \$495. Contact Phil Wells, Battelle Memorial Institute, 505 King Ave., Columbus,

OH 43201-2693, (614) 424-7249. *April 10-11*

### ● SYSTEMS DEVELOPMENT AND FOURTH

GENERATION—Structured Techniques Using Fourth Generation Languages, Chicago, IL. This seminar explains how to use fourth-generation languages in a structured systems development environment. Contact Digital Consulting Associates Inc., 6 Windsor St., Andover, MA 01810, (617) 470-3870. *April 10-12*

### ● COMMUNICATIONS TECHNOLOGY FOR THE

NONVERBAL—The Fourth Annual Conference on Communication Technology: Technology and Nonspeaking Children, Joseph Stokes Auditorium, Children's Hospital of Philadelphia, PA. Up-to-the-minute information on the use of technology with nonverbal children will be presented. Concurrent sessions will address ongoing research, computers, and treatment strategies. The registration fee is \$95. Contact Joan Bruno, Children's Seashore House, 4100 Atlantic Ave., POB 4111, Atlantic City, NJ 08404, (609) 345-5191, ext. 278. *April 12-13*

### ● MAC IS FEATURED

MacFair, Creese Student Center, Drexel University, Philadelphia, PA. Seminars, demonstrations, and exhibits. Student-sponsored. Contact MacFair, The DUsers, Creese Student

Center, Drexel University, Philadelphia, PA 19104, (215) 895-2573. *April 13*

### ● COMPUTERS AND PEOPLE—CHI '85: Human

Factors in Computing Systems, Hyatt Regency at Embarcadero Center, San Francisco, CA. Contact ACM Conference Management, 11 West 42nd St., New York, NY 10036, (212) 869-7440. *April 14-18*

### ● OPTICAL STORAGE

INVESTIGATED—The 1985 Materials Research Society Symposium D, Golden Gateway Holiday Inn, San Francisco, CA. The mass-storage technologies symposium will investigate optical data storage. Areas to be addressed include write-once and erasable media, read-only technology, substrates, and lasers. Contact D. H. Davies, Symposium Co-Chair, 3M, 420 North Bernardo Ave., Mountain View, CA 94043. *April 15-18*

### ● SEMINAR CONSIDERS

CAD—Computer-Aided Design, Ramada Inn, Rochelle Park, NJ. A seminar featuring PCAD and AutoCAD products. Contact Compu-Sales Corp., 1096 Goffle Rd., Hawthorne, NJ 07506, (201) 427-5949. *April 16*

### ● BUCKEYE SHOW

The Ninth Annual Computer Fair, University of Dayton Arena, OH. Terminals, microcomputers, and word processors to be displayed.

Contact Dan Schumacher, University of Dayton, 300 College Park Ave., Dayton, OH 45469, (513) 229-3511. *April 16-17*

### ● DBM AND FOURTH

GENERATION—Database Management Systems and Fourth Generation Languages for Personal Computers, Atlanta, GA. Topics include approaches for managing data, operational considerations, and management issues. The fee is \$795. Contact Software Institute of America Inc., 8 Windsor St., Andover, MA 01810, (617) 470-3880. *April 17-19*

### ● OFFICE, DP EQUIPMENT

CeBIT '85, Hannover, West Germany. More than 1300 exhibitors from more than 25 countries will display office equipment and data-processing technology. Held in conjunction with the Hannover Fair. Contact Hannover Fairs Information Center, Route 22 East, POB 338, Whitehouse, NJ 08888, (800) 526-5978; in New Jersey, (201) 534-9044. *April 17-24*

### ● NETWORK CONTROL

AND MANAGEMENT—Network Management/Technical Control, Marriott Copley Place, Boston, MA. Diagnostic and test instruments will be among the products displayed. Contact Louise Myerow, Registration Manager, CW/Conference Management Group, 375 Cochituate Rd., POB 880, Framingham, MA 01701, (800) 225-4698; in Massachusetts, (617) 879-0700. *April 18-19*

.....  
IF YOU WANT *your organization's public activities listed in BYTE's Event Queue, we need to know about them at least four months in advance. Send information about computer conferences, seminars, workshops, and courses to BYTE, Event Queue, POB 372, Hancock, NH 03449.*

(continued)





Bulgarian Academy of Sciences, Institute of Industrial Cybernetics and Robotics, 113 Sofia, Acad. G. Bonchev St., Bl. 12, Bulgaria; tel: 72-46-98; Telex: 22836 ITRK BG. April 23-26

● **EXPERT SYSTEMS**  
Expert Systems and Knowledge Engineering, Gottlieb Duttweiler Institute, Ruschlikon/Zurich, Switzerland. The theme is "Essential Elements of Advanced Information Technology." Contact Dr. T. Bernold, Gottlieb Duttweiler Institute, CH-8803, Ruschlikon/Zurich, Switzerland. April 25-26

● **MICROS IN EMPIRE STATE**—The Fourth Annual New York Computer Show and Software Exposition, Nassau County Coliseum, Uniondale, NY. Contact Ann Katcef, CompuShows, POB 3315, Annapolis, MD 21403, (800) 368-2066; in Annapolis, (301) 263-8044; in Baltimore, (301) 269-7694; in the District of Columbia, (202) 261-1047. April 25-28

● **VIRGINIA COMPUTING**  
The Fourth Annual Virginia Computer Show and Software Exposition, Pavilion, Virginia Beach, VA. Contact Ann Katcef, CompuShows, POB 3315, Annapolis, MD 21403, (800) 368-2066; in Annapolis, (301) 263-8044; in Baltimore, (301) 269-7694; in the District of Columbia, (202) 261-1047. April 25-28

● **EQUIPMENT SALE**  
Produx 2000: Wholesale Expo '85, Civic Center, Philadelphia, PA. Six hundred booths of computers, communications devices, and business equipment for sale. Contact Vertical Marketing Corp., POB 557, Bala Cynwyd, PA 19004, (215) 457-2303. April 26-28

● **SPRING WITH COMMONERS**—COMMON's Spring '85 Conference,

Louisville, KY. More than 250 presentations are planned. Contact COMMON, Spring '85 Conference, Suite 1717, 435 North Michigan Ave., Chicago, IL 60611, (312) 644-0828. April 27-May 1

● **INTELLIGENT VISION**  
Intelligent Vision Systems, Holiday Inn, Monterey, CA. The technical and marketing aspects of intelligent vision will be covered. Contact Richard D. Murray, Institute for Graphic Communication Inc., 375 Commonwealth Ave., Boston, MA 02115, (617) 267-9425. April 28-30

● **INTRO TO UNIX**  
Introduction to the UNIX System, Atlanta, GA. The pros and cons of UNIX will be covered. Contact Digital Consulting Associates Inc., 8 Windsor St., Andover, MA 01810, (617) 470-3870. April 29-30

● **C FOR ENGINEERS**  
C Programming for Engineers, University of Michigan, Dearborn. A short course and workshop. Contact Professor R. E. Little, University of Michigan, 4901 Evergreen Rd., Dearborn, MI 48128, (313) 593-5241. April 29-May 3

● **KNOWLEDGE ENGINEERING**—Knowledge Engineering: A Short Course, University of Tennessee Space Institute, Tullahoma. Contact Professor Moonis Ali, University of Tennessee Space Institute, Tullahoma, TN 37388-8897, or call the Short Course Office at (615) 455-0631, ext. 278. April 29-May 3

● **COMMERCIAL AI, HIGH-TECH CONFERENCE**—AI 1985: Artificial Intelligence and Advanced Computer Technology Conference/Exhibition, Convention Center, Long Beach, CA. More than 20 technical sessions as well

(continued)

# "There's no magic to using your personal computer for data acquisition."

Fred Molinari, President

There's no trick to it. Just take your choice of our new single board plug-ins and bring complete analog and digital I/O capabilities to your personal computer.

Whether you're working in laboratory research or industrial process control, our single boards can give you measurement and control capabilities without having to spend big bucks.

And who knows that better than the leading supplier of low cost data acquisition boards, systems, and software?

Our boards include A/D with programmable gain, D/A, digital I/O, clock and direct memory access capabilities. With power and performance to match your PC, our analog interfaces provide 12 or 16-bit A/D resolution and direct connection for high or low level signal inputs.

And these boards just plug into the PC's backplane. No messy external boxes or cables. User input connections are simple with our compatible line of screw terminal panels.

Comprehensive user manuals with many programming examples get you up and running fast.

So why look any further? No other analog I/O systems can offer PC users such quality, power and performance for

such a reasonable price.

After all, making data acquisition easy is what we're all about.

And that's no illusion.

Call (617) 481-3700,



DATA ACQUISITION FOR PC'S					
	12-BIT A/D	12-BIT D/A	DIGITAL I/O	PROG CLOCK	SOFTWARE LIBRARY
IBM PC™	X	X	X	X	X
APPLE II™	X			X	
T1 PROFESSIONAL™	X	X	X	X	X
DEC RAINBOW™	X	X	X	X	X
COMPAQ™ Portable	X	X	X	X	X



Data Translation is the leading supplier of personal computer hardware and software for data acquisition and control.

## DATA TRANSLATION

World Headquarters: Data Translation Inc., 100 Locke Dr., Marlboro, MA 01752 (617) 481-3700 Tlx 951-646.  
European Headquarters: Data Translation, Ltd., 430 Bath Rd., Slough, Berkshire SL1 6BB England (06286) 3412 Tlx 849-952.  
In Canada: (416) 625-1907.  
IBM PC is a registered trademark of IBM. Apple II is a registered trademark of Apple Computer Corp. T1 Professional is a registered trademark of Texas Instruments, Inc. DEC Rainbow is a registered trademark of Digital Equipment Corp. COMPAQ is a registered trademark of COMPAQ Computer Corp.







# THE PROFESSIONAL'S CHOICE

Lotus 1-2-3 <b>\$299</b>	Lotus Symphony <b>\$419</b>	dBase III <b>\$339</b>	FrameWork <b>\$339</b>	MultiMate <b>\$259</b>	WordStar 2000+ <b>\$319</b>
--------------------------------	-----------------------------------	---------------------------	---------------------------	---------------------------	-----------------------------------

## Software

### Word Processing Editors

EASYWRITER II	\$219
SYSTEM	\$139
FANCY FONT	\$189
FINAL WORD	\$239
MICROSOFT WORD	\$289
W/MOUSE	\$259
MULTIMATE	\$ 95
PFS: WRITE	\$Call
SAMNA WORD III	\$159
VOLKSWRITER	\$309
DELUXE	\$105
VOLKSWRITER	\$249
SCIENTIFIC	\$319
THE WORD PLUS	\$199
(OASIS)	\$269
WORD PERFECT	\$319
WORDPLUS W/BOSS	\$199
WORDSTAR	\$269
WORDSTAR 2000	\$319
WORDSTAR 2000+	\$259
WORDSTAR	\$229
PROFESSIONAL	
XYWRITE II+	

### Spreadsheets/

Integrated Packages	
ELECTRIC DESK	\$209
ENABLE	\$459
FRAMEWORK	\$339
LOTUS 1-2-3	\$299
MULTIPLAN	\$135
OPEN ACCESS	\$299
SMART SYSTEM	\$559
SPREADSHEET	
AUDITOR	\$ 79
SUPERCALC 3	\$199
SYMPHONY	\$419
TKI SOLVER	\$269

### Desktop

Environments	
DESK ORGANIZER	\$129
GET ORGANIZED	\$159
SIDEKICK	\$ 45
SPOTLIGHT	\$109

### Communications/

Productivity Tools	
CROSSTALK	\$105
PROKEY	\$ 89
RELAY	\$ 99
SMARTCOM II	\$109

### Database Systems

ALPHA DATA BASE	\$179
MANAGER II	\$139
CLOUT V 2.0	\$299
CONDOR III	\$259
DBASE III	\$339
DBASE III	\$319
INFOSTAR+	\$269
KNOWLEDGEMAN	
PFS: FILE/PFS:	\$169
REPORT	\$219
POWERBASE	\$169
QUICKCODE III	\$259
R BASE 4000	

### Languages/Utilities

CONCURRENT DOS	\$189
C86 C COMPILER	\$299
DIGITAL RESEARCH	
C COMPILER	\$219
DR FORTRAN 77	\$219
LATTICE C COMPILER	\$Call
MICROSOFT C	
COMPILER	\$309
MS BASIC COMPILER	\$249
MS FORTRAN	\$239
NORTON UTILITIES—	
NEW	\$Call
TURBO PASCAL	\$45

### Project

Management	
HARVARD PROJECT	
MANAGER	\$219
HARVARD TOTAL	
PROJECT MANAGER	\$299
MICROSOFT	
PROJECT	\$159
SCITOR PROJECT	
5000 W/GRAPHICS	\$289

### Professional

Development	
MANAGEMENT EDGE	\$159
SALES EDGE	\$159
THINK TANK	\$119

### Home/Personal

Finance	
DOLLARS AND	
SENSE	\$119
FINANCIER II	\$119
HOWARD TAX	
PREPARER 85	\$195
MICROTAX	\$Call
MANAGING YOUR	
MONEY	\$129

### Graphics/Statistics

ABSTAT	\$279
AUTOCAD	\$Call
BPS BUSINESS	
GRAPHICS	\$229
CHARTMASTER	\$239
CHARTSTAR	\$209
DR DRAW	\$199
ENERGRAPHICS W/	
PLOTTER	\$279
EXECUVISION	\$259
GRAPHWRITER	
COMBO	\$389
MS CHART	\$159
OVERHEAD	
EXPRESS	\$139
PC DRAW	\$259
PC PAINTBRUSH	\$ 89
PFS: GRAPH	\$ 95
SIGNMASTER	\$179
STATPRO	\$Call
STATPAK-NWA	\$329
STATPAC-WALONICK	\$299

### Accounting Modules

BPI	\$329
GREAT PLAINS	\$479
IUS EASYBUSINESS	\$309
MBA	\$369
OPEN SYSTEMS	\$399
PEACHTREE	\$299
REAL WORLD	\$469
STATE OF THE ART	\$389
STAR ACCOUNTING	
PARTNER	\$249
STAR ACCOUNTING	
PARTNER II	\$599

## Hardware \*

### Multifunction Boards

AST ADVANTAGE	\$Call
AST 6 PAK PLUS (64K)	\$249
AST 6 PAK PLUS	
(384K)	\$449
AST MEGAPLUS II (64K)	\$269
AST MEGAPAK (256K)	\$349
QUADBOARD (64K)	\$269
QUADBOARD (256K)	\$399
QUADBOARD EXP.	
(64K)	\$269
QUADBOARD EXP.	
(384K)	\$469
QUAD 512+ (64K)	\$269
ORCHID BLOSSOM	\$Call
PERSYST	\$Call
TECMAR CAPTAIN(64K)	\$279
TECMAR WAVE (64K)	\$209

### Display Boards

AST MONOGRAPH PLUS	\$Call
EVEREX GRAPHICS	
EDGE	\$419
HERCULES GRAPHICS	
CARD	\$329
HERCULES COLOR	
CARD	\$179
PARADISE MODULAR	
GRAPHICS CARD	\$285
PARADISE	
MULTIDISPLAY CARD	\$285
PERSYST	\$Call
PLANTRONICS	
COLORPLUS	\$419
PRINCETON SCAN	
DOUBLER	\$Call
STB GRAPHICS	
PLUS II	\$309
TECMAR GRAPHICS	
MASTER	\$489
TECMAR VIDEO VAN	
GOGH	\$259
TSENG ULTRA PAK	\$449

### Displays

AMDEK 300G/300A	\$139/149
AMDEK 310A	\$179
AMDEK COLOR II +	\$459
PRINCETON HX-12	\$469
PRINCETON MAX-12	\$179
PRINCETON SR-12	\$Call
QUADRAM	
AMBERCHROME	\$179
ZENITH 124 AMBER	\$145
ZENITH 135 COLOR	\$Call

### Modems

AST REACH 1200	\$Call
HAYES 1200	\$459
HAYES 1200B	\$399
HAYES 2400	\$Call
VENTEL 1200	
HALF CARD	\$Call

### Accessories

CURTIS SURGE	
PROTECTORS	\$Call
EPD SURGE	
PROTECTORS	\$Call
GILTRONIX A/B SWITCH	\$Call
MICROBUFFER INLINE	
(64K)	\$264
MICROFAZER INLINE	
(64K)	\$219
64K RAM SET	\$40
256K RAM SET	\$Call
8087 MATH	\$150

### Printers/Plotters

AMPLIT II	\$859
C. ITOH	\$Call
COMWRITER II	\$Call
COMWRITER 420	\$Call
DIABLO 620/630	\$Call
EPSON FX-100+	\$Call
EPSON LQ-1500	\$Call
EPSON JX-80	\$419
JUKI 6100	\$899
NEC P3	\$769
NEC 2050	\$1399
NEC 3550	\$729
OKIDATA 84P	\$619
OKIDATA 93P	\$1569
QUME SPRINT 1155	\$1279
TOSHIBA P1351	
SWEET P 6 PEN	
PLOTTER	\$899

### Emulation Boards

ASTPCOX	\$949
AST 3780	\$609
AST SNA	\$689
AST BSC	\$ 29
BLUE LYNX	\$Call
CXI 3278/9	\$Call
IRMA	\$869
IRMALINE	\$999
IRMAPRINT	\$Call
QUAD 3278	\$949

### Input Devices

KEYTRONIC 5151	\$189
MICROSOFT	
MOUSE	\$139
PC MOUSE W/PAINT	\$159

### Mass Storage

ALLOY PC-BACKUP	
20MB	\$1649
ALLOY PC-DISC	
20MB	\$1769
OMEGA 10+10 MB	\$2895
MAYNARD WS-1 10MB	\$Call
SIGMA	\$Call
SYSGEN IMAGE	\$Call
TALLGRASS HARDFILE	
+ TAPE	\$Call
TEAC HALF HEIGHT	\$159

### Networks

AST PC NET	\$Call
CORVUS NET	\$Call
DIGITAL RESEARCH	
STARLINK	\$1199
ORCHID PC NET	\$Call

\*CALL FOR SHIPPING COSTS

Samna  
Word III  
**\$CALL**

Chart-Master  
**\$239**

AST 6 Pak  
Plus  
**\$249**

Quad Board  
Expanded 64K  
**\$269**

Smartmodem  
1200B  
**\$399**

Smartmodem  
1200  
**\$459**



## LOWEST PRICE GUARANTEE!!

We will match current nationally advertised prices on most products. Call and compare.

*free!*

Diskette Library Case with your order



# 1-800-221-1260

In New York State call (718) 438-6057

### TERMS:

Checks—allow 14 days to clear. Credit processing—add 3%. COD orders—cash, M.O or certified check—add \$3.00. Shipping and handling UPS surface—add \$3.00 per item (UPS Blue \$6.00 per item). NY State Residents—add applicable sales tax. All prices subject to change.



MON.-THURS. 9:00 AM-8:00 PM  
SUN. & FRI. 9:00 AM-4:00 PM

# Softline

Softline Corporation  
P.O. Box 729, Brooklyn, N.Y. 11230  
TELEX: 421047 ATLN UI



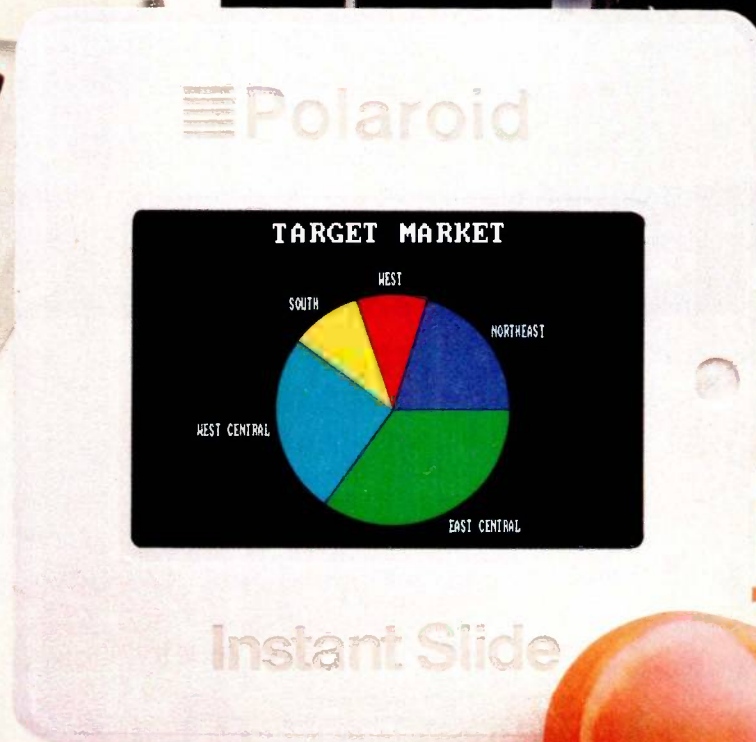
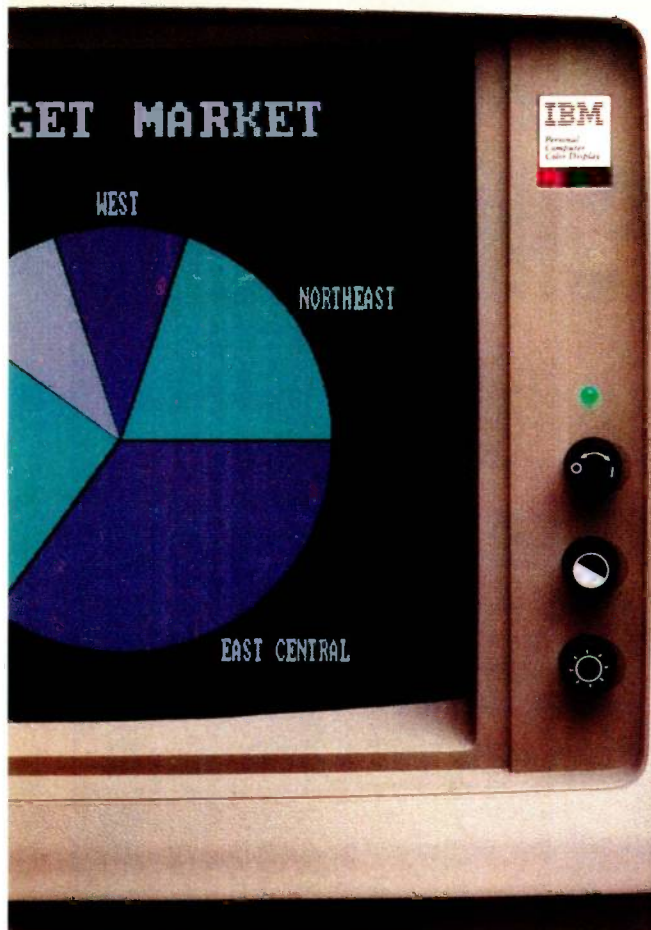

A black border may appear around the Palette slide image, which will be imperceptible when projected.

# Now last minute presentations can be made from your personal computer. In color. In house. In minutes.

## Introducing Polaroid Palette.

Whether your presentation is in 30 minutes or 30 days, the new Polaroid Palette Computer Image Recorder will make it easier. Priced at under \$1800\*, it lets you make Polaroid instant 35mm slides or prints from personal computer-generated data. Right at your desk. So now you can create a presentation in minutes. Without sending out for processing, paying premiums for rush service or risking the security of your confidential information.

**Works with the graphics packages of the IBM PC or XT, DEC Rainbow or PRO, Apple IIe or II+ and AT&T 6300.**

The Polaroid Palette is designed to work with many graphics software packages. In fact, when using such popular programs as Graphwriter, Chart-Master, Sign-Master, DR Draw and DR Graph, Palette can virtually double both the horizontal and vertical resolution of your monitor. Plus, a

"backfill" feature reduces raster lines for a smoother, more finished appearance. The result—presentation quality slides. On-the-spot.

**Color 35mm slides, even from a black and white CRT**

Think of it as an artist's palette. Because Palette "paints" your graphs, charts and text. You're choosing from up to 72 colors. If you don't want red, press a few keys—it's green. And if you're not the artistic-type, Polaroid has developed a menu of color sets: combinations of colors that have been specially coordinated to complement your presentations. And all of this is yours, even if you have a black and white monitor.

**Lets you make last minute changes or add up-to-the-minute information.**

The Polaroid Palette is the fast, convenient, low-cost way to prepare slides for your presentation. And perhaps

even more important, Palette allows you to keep confidential information confidential. You won't have to send your work out to anyone again.

So why wait until the last minute to find out about Polaroid Palette? Call this toll-free number or return this coupon. Because with Palette you'll make your deadlines, in no time.

For a demonstration, call toll-free, or mail the coupon to Polaroid Corp., E.I. Marketing, Dept. 604, 575 Technology Sq., Cambridge, MA 02139.

**CALL 1-800-225-1618**

Send information.  Have representative call.

Name \_\_\_\_\_ Title \_\_\_\_\_

Company \_\_\_\_\_

Address \_\_\_\_\_

City \_\_\_\_\_ State \_\_\_\_\_ Zip \_\_\_\_\_

Telephone (\_\_\_\_) \_\_\_\_\_

PC make and model \_\_\_\_\_

 **Polaroid**

B-4/85

\*Suggested list price. Polaroid\*



pean Conference on Integrated Optics, Berlin, Federal Republic of Germany. More than 250 engineers and scientists from Europe, Japan, and the United States will discuss the potential of optics for communication, signal processing, and instrumentation. Contact ECIO '85 Conference Secretariat, Frau I. Weber-Zuckarelli, Heinrich-Hertz-Institut Berlin GmbH, Einsteinufer 37, D-1000 Berlin 10, Federal Republic of Germany. *May 6-8*

● **SPRING COMDEX**  
COMDEX Spring, Atlanta, GA. More than 750 companies will exhibit. Contact The Interface Group Inc., 300 First Ave., Needham, MA 02194, (800) 325-3330; in Massachusetts, (617) 449-6600. *May 6-9*

● **MAPLE LEAF COMPUTING**—The 1985 Canadian High Technology Show, Civic Centre, Ottawa, Ontario, Canada. Product displays, speakers, and tutorials. Contact Canadian High Technology Show, Suite 214, 2487 Kaladar Ave., Ottawa, Ontario K1V 8B9, Canada, (613) 731-9850. *May 7-8*

● **MEMORY CARDS STUDIED**—Memory-Card Technology, Crowne Plaza, San Francisco, CA. See April 10-11 for details. *May 8-9*

● **PC DISPLAYS**  
PC Expo, Convention Centre, Montreal, Quebec, Canada. Contact PC Expo, 20 But-terick Rd., Toronto, Ontario M8W 3Z8, Canada, (416) 252-7791. *May 8-10*

● **TOPICS IN COMPUTER LAW**—The Sixth Annual Computer Law Institute, Los Angeles, CA. Topics on the docket include proprietary rights issues in the design of compatible products, product distribution, and anti-

trust and copyright issues. Contact Cheryl Litrenta, University of Southern California Law Center, University Park, Los Angeles, CA 90007, (213) 743-2582. *May 9-10*

● **C CONVOCATION**  
C85: The First International Conference on the C Programming Language, Ramada Renaissance Hotel, San Francisco, CA. A forum for programmers and developers using or considering the use of the C language. Sessions on ANSI X3J11 standard, portability, programming tools, and applications. Contact Lifeboat Associates, 1651 Third Ave., New York, NY 10128, (800) 847-7078; in New York, (212) 860-0300. *May 13-15*

● **GRAPHICS FOR ENGINEERING, DRAFTING**  
Computer Graphics for Engineering/Drafting Practice and Computer Graphics Workshop, University of Texas, Austin. These short courses stress learning the principles of computer graphics and seek to develop the ability to prescribe computer graphics equipment for engineering applications. Contact College of Engineering, University of Texas, Austin, TX 78712, (512) 471-3506. *May 13-17*

● **PROFESSIONAL TUTORIALS**—Tutorials for Professional Development, Hyatt Hotel, Los Angeles, CA. A series of all-day seminars on software, logic programming, and communications. Contact Gerry Segal, Association for Computing Machinery, 11 West 42nd St., New York, NY 10036, (212) 869-7440. *May 13-17*

● **TEST, MEASUREMENT EXPO**—The 1985 Test and Measurement World Expo, Convention Center, San Jose, CA. Conferences and technology exhibits. Contact

Meg Bowen, Test and Measurement World Expo, 215 Brighton Ave., Boston, MA 02134, (617) 254-1445. *May 14-16*

● **MODULA-2 ENGINEERING**—Software Engineering with Modula-2, Atlanta, GA. A course emphasizing methods for building large-scale software systems in Modula-2. Prerequisite: knowledge of Ada or Pascal. The fee is \$495. Contact Elaine Hadden Nicholas, Department of Continuing Education, Georgia Institute of Technology, Atlanta, GA 30332-0385, (404) 894-2547. *May 15-17*

● **OK SHOW**  
The Eighth Annual Show & Tell Microcomputer Conference, University of Oklahoma, Norman. Micro-computer fans of all ages and levels of expertise come together to share ideas and demonstrate applications and hardware. Contact Richard V. Andree, Show & Tell Computer Conference, Mathematics Department, University of Oklahoma, 601 Elm St., Norman, OK 73019. *May 18*

● **MANAGEMENT CONGRESS**—Update '85, Sheraton Hotel, Brussels, Belgium. A briefing covering technological developments for those in the information management and micro-graphic industries. Contact Update '85, International Information Management Congress, POB 34404, Bethesda, MD 20817, (301) 983-0604. *May 20-22*

● **CAD TECHNOLOGY**  
CAD 2001: The Countdown, Dallas, TX. Presentations on the future of computer-aided design. The fee is \$900. Contact CAD Seminars Inc., Suite 400, 150 East Riverside, Austin, TX 78704, (512) 445-7342. *May 22-24*

● **SOFTWARE AND HUMAN DEVELOPMENT**  
Computer Software and Human Development Conference, Royal York Hotel, Toronto, Ontario, Canada. Held in conjunction with the Third Annual Software Panorama, this conference will examine the impact of software development on business, education, health, and agriculture. Contact Reuben Lando, The Software Developers Association, Suite 500, 185 Bloor St. E., Toronto, Ontario M4W 1C8, Canada, (416) 922-1153. *May 22-24*

● **DISK STORAGE EXPO**  
The 1985 International Videodisc, Optical Disk, and CD-ROM Conference and Exposition, London West Hotel, London, England. Workshops, presentations, and exhibitions. Contact Angela Suter, Meckler Communications, 11 Ferry Lane W, Westport, CT 06880, (203) 226-6967; in England, Alice Taylor, Meckler Communications, c/o Eurospan, 3 Henrietta St., London WC2E 8LU, England; tel: 01 240-0856. *May 29-31*

● **MANAGE PROGRAMS**  
Configuration Management of Software Programs, Washington, DC. Methods for controlling the costs of development, maintenance, and operation of software. Contact Stod Cortelyou, Continuing Engineering Education, George Washington University, Washington, DC 20052, (800) 424-9773; in the District of Columbia, (202) 676-8520. *May 29-31*

● **COMPUTER INTER-FACING**—Personal Computer and STD Computer Interfacing for Scientific Automation, Virginia Polytechnic Institute and State University, Blacksburg. A hands-on workshop with participants wiring and testing interfaces. The fee is \$450. Contact Dr.

## EVENT QUEUE

Linda Leffel, C.E.C., Virginia Polytechnic Institute and State University, Blacksburg, VA 24061, (703) 961-4848. *May 30-June 1*

### June 1985

● **LEARN TO BUILD PROGRAMS**—First North American Summer School on Program Construction, Newport, RI. Methods for the effective construction of software will be taught. Contact Teleprocessing Inc., 60 State St., Boston, MA 02109, (617) 367-6227. *June 3-12*

● **INTERFACES FOR SCHOOL LABS**—Interfacing for School Laboratories, Miami University, Oxford, OH. A workshop for secondary-school and college teachers on the construction and use of interfaces for laboratory instrumentation. Contact Bill Rouse, 301 McGuffey Hall, Miami University, Oxford, OH 45056, (513) 529-2141. *June 3-14*

● **COMPUTER MAINTENANCE**—Independent Computer Maintenance, Halloran House, New York, NY. Contact Carol Every, Frost & Sullivan Inc., 106 Fulton St., New York, NY 10038, (212) 233-1080. *June 5-6*

● **OPTICAL-STORAGE CONFERENCE**—First Annual Conference on Optical Storage for Small Systems, Biltmore Hotel, Los Angeles, CA. Contact Technology Opportunity Conference, POB 14817, San Francisco, CA 94114-0817, (415) 626-1133. *June 5-7*

● **COMPUTERS FOR SALE**—Computer Supermarket, San Mateo County Fairgrounds, San Mateo, CA. Retailers, manufacturers, and distributors will be selling hard-

ware and software. Admission is \$7; children \$3. Contact Microshows, Suite 203, 1209 Donnelly Ave., Burlingame, CA 94010, (415) 340-9113. *June 8-9*

● **COMPUTER VISION CONFERENCE**—Computer Vision and Pattern Recognition Conference, Cathedral Hill Hotel, San Francisco, CA. Submitted and invited technical papers. Contact Computer Vision and Pattern Recognition, POB 639, Silver Spring, MD 20901, (301) 589-8142. *June 9-13*

● **MUMPS MEETING**—The Fourteenth Annual Meeting of the MUMPS Users' Group, McCormick Center Hotel, Chicago, IL. Tutorials, workshops, site visits, discussions, and exhibits. Contact MUMPS Users' Group, Suite 510, 4321 Hartwick Rd., College Park, MD 20740, (301) 779-6555. *June 10-14*

● **ROBOTIC STRATEGIES**—Robot Manipulators, Computer Vision, and Intelligent Robot Systems, University of Stirling, Stirling, Scotland. A short course for professionals emphasizing the development of strategies for the solution of robotic-sensing, spatial-reasoning, and manipulation problems. Contact Director of the Summer Session, Massachusetts Institute of Technology, Room E19-356, Cambridge, MA 02139. *June 10-14*

● **NETWORK CONTROL AND MANAGEMENT**—Network Management/Technical Control, Santa Clara Marriott, Santa Clara, CA. See April 18-19 for details. *June 12-13*

● **CLINICAL COMPUTING**—Computing in Clinical Laboratories: The Fifth International Conference, Stuttgart, Federal Republic of

(continued)

# CAN YOURS DO THIS?

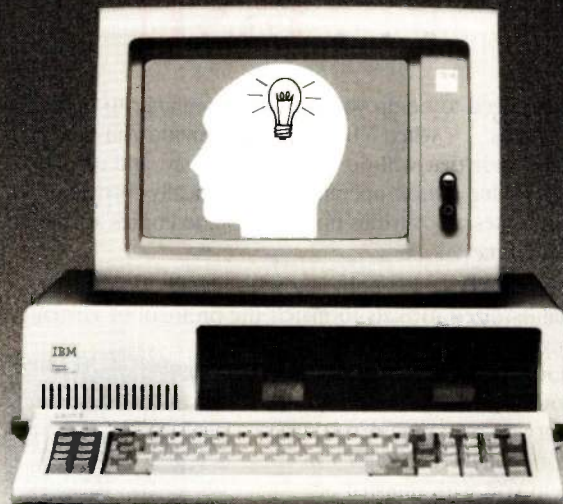

## DISCOVER muLISP™ The Artificial Intelligence Package for Micros.

muLISP includes:

- An integrated environment for A.I. program development.
- A high performance, pseudo-code compiler and interpreter for the LISP programming language.
- A resident, screen-oriented LISP editor and debugging system.

Available for your IBM PC™, MS-DOS™, CP/M™, and Apple™ II SoftCard computers.

We also offer muMATH™, the symbolic math calculator for micros.



Soft  
Warehouse INC

Founded 1979

P.O. Box 11174, Honolulu, HI 96828-0174 • (808) 734-5801 (Afternoon PST)  
MC/VISA MCI ID: 241-7437 © 1985 Soft Warehouse

**YES!** I'd like to know more about muLISP and muMATH. Please send me more information today.

Name \_\_\_\_\_

Address \_\_\_\_\_

City \_\_\_\_\_ State \_\_\_\_\_ Zip \_\_\_\_\_

Company \_\_\_\_\_

Position \_\_\_\_\_



# 100% FLAWLESS COPIES . . .

. . . **FAST!**

No need to tie up your valuable computer to duplicate diskettes . . . when VICTORY can provide you with a duplicator that will do the job flawlessly, and much faster. One button operation automatically formats, duplicates and verifies up to 8 diskette copies at the same time.

VICTORY can supply you with literally dozens of standardized formats to match the protocol of virtually any current computer. In addition, built-in utilities enable you to read or devise any format you may require. If that's not enough, VICTORY can help you with unusual or unique formatting, serializing or copy-protecting problems.

VICTORY duplicators are designed to be reliable. Each of the copy drives has a separate controller to increase copying throughput and ensure maximum uptime. VICTORY Duplicators use industry proven drives combined with 100% digital technology . . . there are no analog circuits to slowly drift out of tolerance.

Let us help free you from your disk-duplicating bottleneck at a surprisingly attractive price. Write or call: VICTORY ENTERPRISES TECHNOLOGY, INC., 8910 Research Blvd., Suite B2, Austin, Texas 78758—(512) 450-0801.

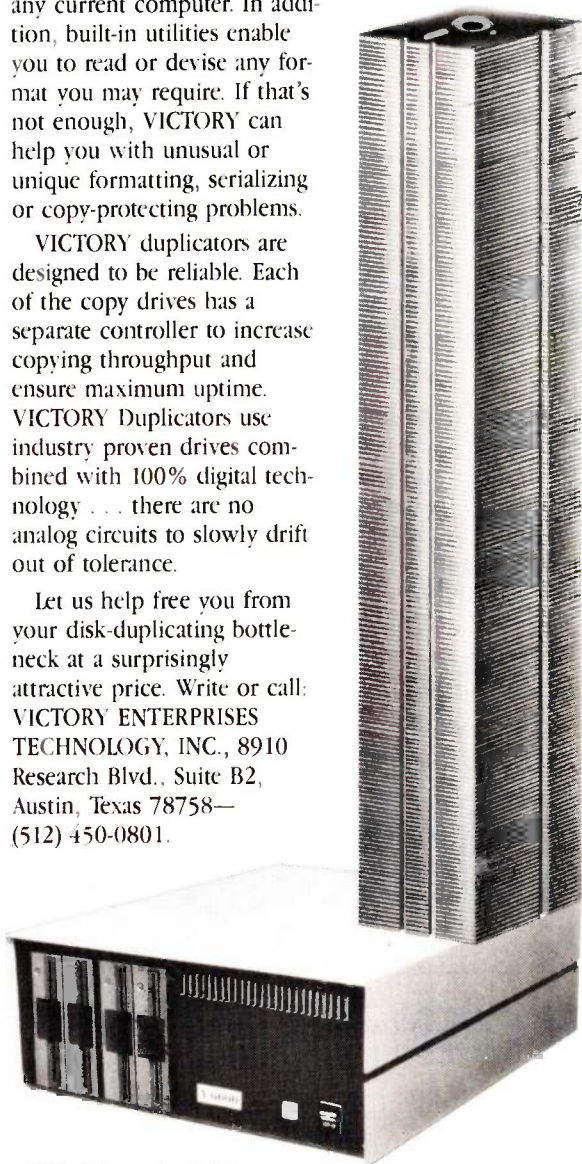

**VICTORY  
ENTERPRISES**  
Technology, Inc.

## EVENT QUEUE

Germany. Topics on the agenda include databases, data presentation, and expected developments. Demonstrations and exhibits. Contact PD Dr. Chr. Trendelenburg, Katharinenhospital KCI, Kriegsbergstrasse 60, D-7000 Stuttgart 1, Federal Republic of Germany; tel: (07 11) 20 34-482. *June 12-14*

● **COMPUTERS IN CLINICAL LABS**—Clinical Laboratory Computers, Symposium 1985, The Towsley Center, University of Michigan, Ann Arbor. Contact Dove Margenau, Office of Continuing Medical Education, The Towsley Center, Box 057, The University of Michigan Medical School, Ann Arbor, MI 48109-0010, (313) 763-1400. *June 12-14*

● **INFO MANAGEMENT EXPO, CONFERENCE** Info/West: The Western Information Management Exposition and Conference, Convention Center, Anaheim, CA. Trade show for executives and data-processing and management-information system managers. Contact Info/West, 999 Summer St., Stamford, CT 06905, (203) 964-8287. *June 12-14*

● **FORTH CONFERENCE** The 1985 Rochester FORTH Conference, University of Rochester, Rochester, NY. The focus will be on software engineering and management. Contact Ms. Maria Gress, Institute for Applied FORTH Research, 70 Elmwood Ave., Rochester, NY 14611, (716) 235-0168. *June 12-15*

● **LOGICAL MACHINES CONFERENCE**—The Second Annual Conference on Logic, Logic Machines, and Public Education, University of Houston-Clear Lake, Houston, TX. Formal and informal sessions, symposia, and

workshops. Contact the Institute for Logic and Cognitive Studies, University of Houston-Clear Lake, Box 269, Houston, TX 77058, (713) 488-9274. *June 13-15*

● **INTERNATIONAL SHOW** The International Computer Show, Trade Fair Center, Cologne, West Germany. More than 350 manufacturers from more than 18 countries are expected to display their wares. Contact Messe- und Ausstellungs-Ges.m.b.H. Köln, Messeplatz, Postfach 210760, D-5000 Köln 21, West Germany; tel: (0221) 821-1; Telex: 8 873426 mua d. *June 13-16*

● **PC IN BIG APPLE** PC Expo, Coliseum, New York, NY. Seminars and product displays. Contact PC Expo, 333 Sylvan Ave., Englewood Cliffs, NJ 07632, (800) 922-0324; in New Jersey, (201) 569-8542. *June 17-19*

● **SOFTWARE FOR ENGINEERING**—Engineering Software: Engsoft '85, The Fourth International Conference and Exhibition, Kensington Exhibition Centre, London, England. Exhibits and sessions of software for engineering. Contact Elaine Taylor, Computational Mechanics Centre, Ashurst Lodge, Ashurst, Southampton SO4 2AA, England; tel: (042 129) 3223; Telex: 47388 Attn. COMPMECH. *June 18-20*

● **GRAPHICS IN SUNSHINE** Computer Graphics '85 West, Los Angeles, CA. Contact National Computer Graphics Association, 8401 Arlington Blvd., Fairfax, VA 22031, (703) 698-9600. *June 25-27*

● **CAD TECHNOLOGY** CAD 2001: The Countdown, Boston, MA. See May 22-24 for details. *June 26-28* ■

# Our multi-mode HERMES printers shake hands with all kinds of computers. Even some you've never heard of.



And for your IBM-PC™, we have created the fully compatible multi-mode HERMES PC-PRINTER 1.

Troquer Adverteam

Fully compatible with your IBM-PC™, tested with Easywriter™, Multiplan™, Lotus 1-2-3™ and other software packages, the HERMES PC-PRINTER 1 allows you to convert your personal computer to a heavy duty professional system. IBM-PC™ users who only pick the best will also appreciate:

**Its speed.** Bi-directional, shortest path printing. 200 cps Data, 100 cps Near Letter Quality (single pass).

**Its resolution.** Finest print quality available on a matrix printer. So good you can even print signatures. Bit mapping graphics in single, double and triple density modes.

**Its quality.** Swiss high quality construction. Very high reliability for heavy duty use.

**Its versatility.** Choice of printing styles with the complete IBM™ character set tables (226 chars.). Wide range of automatic sheet-feeders with 1 or 2 bins + envelopes, single document inserter, roll-holder and tractor.

**Its ease of use.** Plug'n play installation. Plug it in, switch it on yourself.

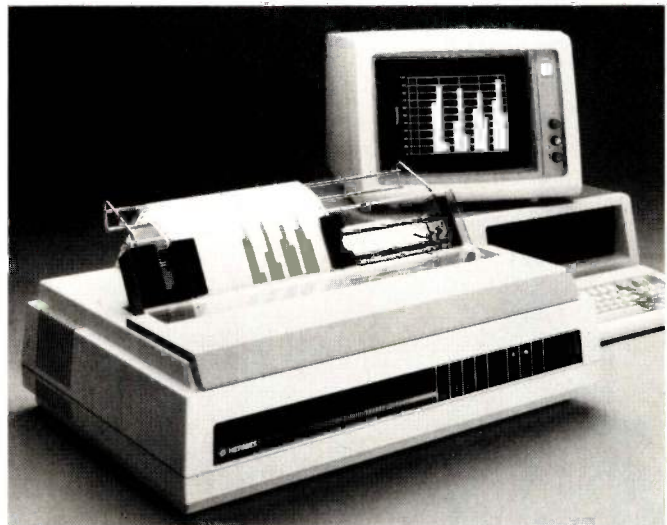

To receive a sample of the finest quality matrix print-out and additional information on the HERMES PC-PRINTER 1, please return the coupon below.



**HERMES®**  
The impressive printers

Manufactured in Switzerland by HERMES PRECISA INTERNATIONAL, CH-1401 Yverdon.

HERMES printers are distributed in Australia, Austria, Canada, Cyprus, Finland, France, Greece, Hong-Kong, Indonesia, Jordan, Kuwait, Lebanon, Macao, Malaysia, New-Zealand, Philippines, Saudi Arabia, Singapore, South Africa, South Korea, Spain, Sweden, Switzerland, Taiwan, Thailand, United Kingdom, USA, West Germany.

Contact factory direct for OEM sales of print-heads and printer mechanisms.

Please send me more documentation about your PC-PRINTER 1.

Name \_\_\_\_\_ Title \_\_\_\_\_  
 Company \_\_\_\_\_  
 Street \_\_\_\_\_ City \_\_\_\_\_  
 State \_\_\_\_\_ Zip \_\_\_\_\_ Phone ( ) \_\_\_\_\_

Send to: HERMES PRODUCTS, Inc. – Printer Division  
 1900 Lower Road, LINDEN, NJ 07036, (201) 574 0300



**Three more firsts  
from the people who  
invented the wheel.**



**Xerox Advantage  
D-80IF Diablo Printer**



**Xerox  
Advantage  
D-36 Diablo  
Printer**





# XEROX

From day one, Xerox and Diablo have been known as the two best names in daisywheel printers. And now there are three more in the Xerox line to choose from.

The Xerox Advantage D-25 Diablo printer turns out letter quality documents quickly and quietly. And it does all that for the price of a dot matrix printer.

At 80

c.p.s., the D-80IF is the fastest daisywheel printer ever made by Xerox. It has a built-in double bin sheet feeder. As well as the capacity to handle up to 16 computers at once.

And the D-36 spells reliability. It averages 4,000 hours of printing between maintenance calls.

But Xerox didn't stop there. Each of these new machines is compatible with most computers on the market, including the IBM-PC. And they're all easy to use.

They're also a part of Team Xerox, so they can be serviced by the national Xerox service force and authorized service locations across the country.

So if you're looking for the latest in daisywheel printing technology, go with the people who've been in the business the longest. Call 1-800-833-2323, ext. 25, your local Xerox office, an authorized Diablo or Xerox dealer or send your business card to Xerox Corporation, Dept. 25192, P.O. Box 24; Rochester, NY 14692.

For more information from Xerox, circle 405 on the Reader Service card.



Xerox Advantage  
D-25 Diablo Printer



# W·H·A·T'S N·O·T

## Knife the Mac

**E**nnui Associates has announced MacKnifer, a hardware attachment that mounts on the side of your Macintosh and sharpens knives, scissors, lawn-mower blades—anything in your home that needs sharpening. With MacKnifer's patented double-action grinding wheel, you can easily sharpen any utensil in less time than it takes the Mac to open a file. According to the manufacturer, MacKnifer is so easy to use that you can operate it within 30 minutes of taking it out of the box. Turn your spare computing time into



extra cash with a knife-sharpening business on the side . . . of your Macintosh. For more information on

MacKnifer, contact Ennui Associates, 52502 Marginal Ave., Somnolencia, CA 90541.

## Nouveau-Chic Luggage

**T**he Spike Untermyer Luggage Company manufactures hollow replicas of the most popular lap-size and transportable personal computers for use as travel

bags by status-conscious travelers. For example, the Untermyer Executive Portfolio resembles a Tandy Model 100, complete with movable (nonfunctional)

keys. The Executive Portfolio flips open to reveal enough space for a pad, appointment calendar, several pens and pencils, or a couple of peanut butter and jelly sandwiches for that quick executive snack. The Untermyer Overnighter, easily confused with a Compaq, TI, or IBM portable computer, is perfect for that sudden business trip.

Untermyer luggage is painfully authentic. The Overnighter is exactly half an inch too large to fit under the average coach airline seat, and the bottom of the case is heavily weighted to ensure that nasty crack on the shins when you maneuver past the flight attendant.

For more information, contact the Spike Untermyer Luggage Company Inc., 442 Glenwood Ave., Prosaic, NJ 22104.



## One for the Road

**H**onda Corporation has announced the Transporter, the first truly transportable computer. With a few simple twists, you can transform the Transporter from a portable computer (with full keyboard, 24-line by 80-column display, and two microfloppy-disk drives) into a single-passenger automobile.

The Transporter runs on 32 D-cell batteries (not included) with additional one-year battery backup for the ignition, which is in ROM (ride-only memory). Thus, if the Transporter won't start on a chilly winter morning, you can simply give it a cold boot to jog its memory.

Although the Transporter is somewhat heavier than other portable computers, you can easily drive it through airport terminals. Service will be available through AAA (American ASCII Association), which provides pickup and delivery with no tote-charges.

Options include the TP-100 Printer Trailer, the 300-BeePS Modem, and a genuine Naugahyde keyboard cover. Honda has also announced plans to release the SemiPortable, a 20-megabyte hard-disk system that transforms into an 18-wheel tractor/trailer (assembly required).

The Transporter is 100 percent compatible with the popular Toyota Corolla and runs on most operating roads. The cost is \$5995. For more information, contact Honda Corporation Ltd., 2 Duryea Drive, Minikin, MI 48101.

## New Arrival

**C**elebrity Software, maker of the Howard Cosell Word Processor and the Michael Jackson Spreadsheet, has announced the Princess Di Database. If your data is a royal mess, this hierarchical database will arrange things in a neat succession for you. You can obtain output from the system every nine months, with three levels of security: Mum's the Word, Rumor City, and Tell the World.

Available at supermarket checkout counters, the Princess Di Database is priced at \$49.95 from Celebrity Software, 135 Pachelbel Canyon, San Regales, CA 90342.

## New Mag

**H**igh Press Technologies (HipTech) has announced a new publication, *Personal Photocopying*. Designed to make photocopiers less threatening for the average person, the magazine will be written in nontechnical language that explains PRINT, PAUSE, and CANCEL in language that a layperson can understand.

Articles in the first issue of PPC will include "1001 Ways to Make Money with Your Photocopier," "Paper Jam—Deadly Threat to Your Business," and "Big Gray: The Xerox Story."

Based on research done in its own offices, HipTech has also announced *Constant Coffeemaking*. For a one-year subscription to either magazine, send \$25 to POB 123123, South Banausic, WI 03458.

## Home on the Database

**T**hinkFast Software has introduced a revolutionary natural-language database designed for home management. MOM, the Model Management program, is a matriarchal database of home-related subjects that responds to plain-English queries. After entering information about your home, age, eating habits, and shoe size, you enter search phrases in the

format "Where is the screwdriver?" After a quick pass through its files, MOM responds, "Right where you left it—behind the TV set." Enter the search phrase, "Where are my sneakers?" and MOM responds with lightning speed, "I don't know where your sneakers are; I don't wear your sneakers."

ThinkFast has also announced a product for in-

tegration with MOM, one that provides personal advice and guidance. Decisions and Declarations (DAD) responds to the traumas of everyday living with such plain-English messages as, "You want to cry? I'll give you something to cry about!" and "Ask MOM."

MOM and DAD are priced at \$99 each from ThinkFast Software, Duitmy Way, Homeville, NC 28210.

## A Taste of Security

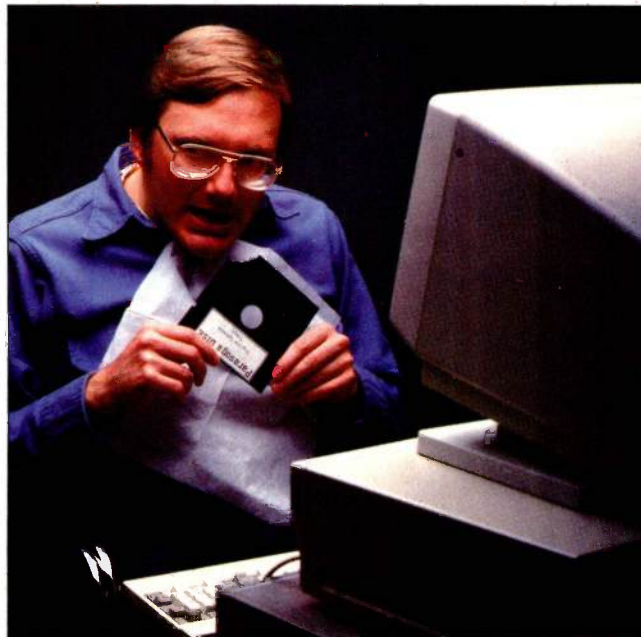

**I**f merely erasing sensitive data is not enough for you, Soy cure Systems of Tokyo has developed the ultimate in disk security. Made entirely of processed soybeans, Parasoja Disks are writable, readable, and edible. Parasoja disks contain 84 percent more pro-

tein than average floppy disks and are available in 5¼-inch (regular) and 3½-inch (crunchy) formats.

Available at computer and health stores everywhere, Parasoja Disks are priced at \$50 per 10-pack from Soy cure Systems, 1 Tufchuying, Tokyo, Japan.

## Keeping Time to Yourself

**I**ncognito, a low-profile time-management program for MS-DOS computers, combines an appointment calendar with 200 stock excuses for breaking or avoiding social engagements.

The Incognito calendar's avoidance categories include: My Mate and I; The Car; Kids, Pets, and Relatives; Let Me Check With My . . . (accountant, boss, etc.); I'm Coming Down With . . . ; and Previous Engagement.

Incognito's Fib-Jogger utility reminds you what you said to whom and tells you when you've ducked someone more than a set number of times. The program also generates fake itineraries, resumes, and credit references.

For your copy of Incognito, send \$395 to ApresHeures Computing, 70 Main St., Paulsboro, NH 03458, (800) 123-4567. Call after 6 p.m. Please allow 10, maybe 12 weeks for delivery.



# Texas Instruments announces Dr. L.S. Montejo Professional

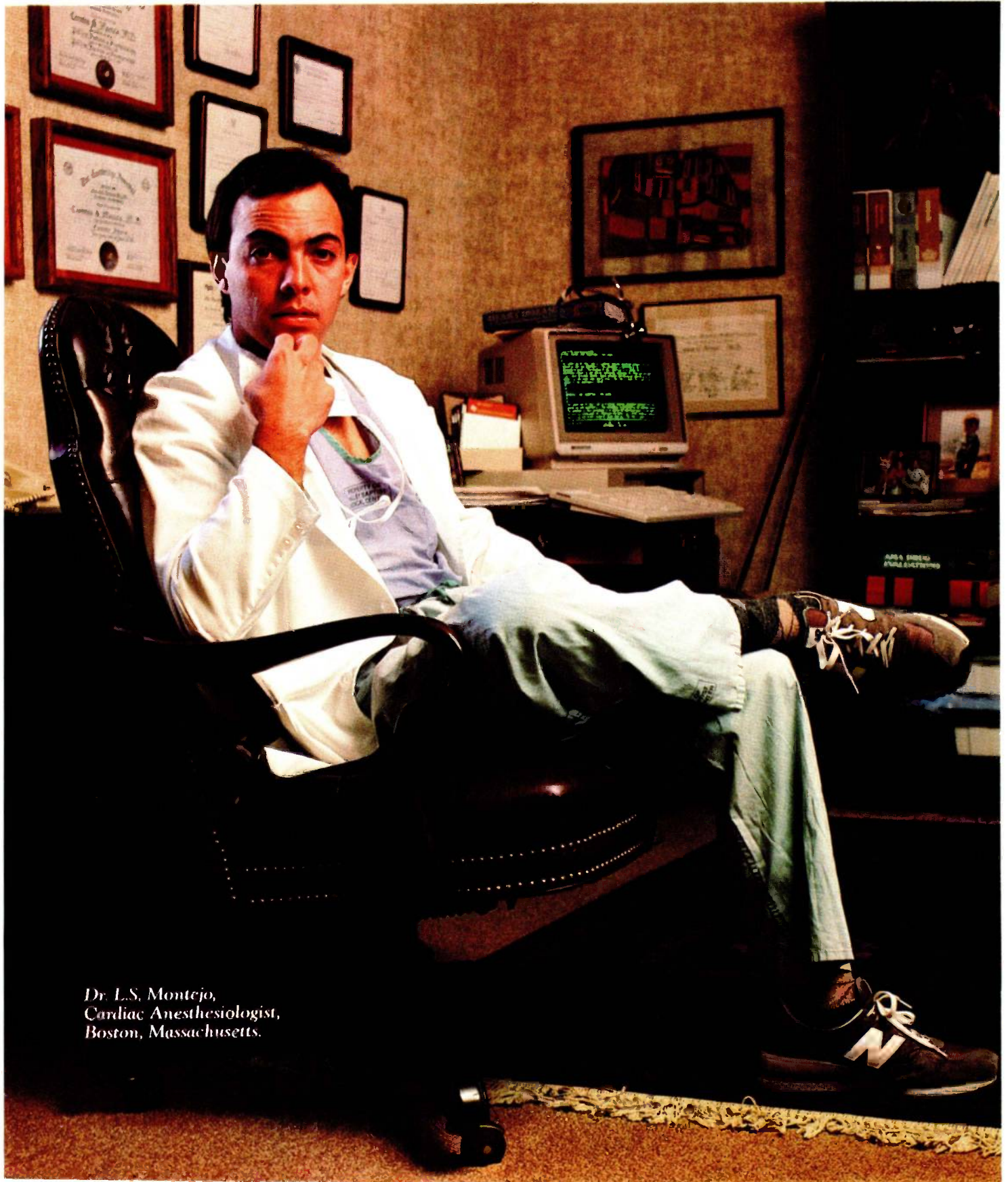

*Dr. L.S. Montejo,  
Cardiac Anesthesiologist,  
Boston, Massachusetts.*



# the Computing System.



No two individuals work alike. TI had unique answers to help Dr. L. S. Montejo keep his patients and his business healthy.

"I used to walk out of the operating room with a clipboard and a chart," says Dr. L. S. Montejo. "Now I walk out with a floppy disk."

Dr. Montejo is a prominent anesthesiologist who is pioneering the use of personal computers in heart surgery. His unique idea for making quicker, more informed decisions led to a unique solution from TI: a portable PC he could talk to. Configured to his exact needs from the wide range of TI options.

"Using TI's Speech Command," he says, "I can respond to drug reactions faster, with the PC making calculations as I speak to it. And my hands are free to do other things.

**"The information just flies by.** But the computer organizes it, and by calling up color charts, I can make better decisions at a glance. It lets me provide better medical care."

In his office, Dr. Montejo uses a desktop TI Professional Computer to keep the business side of his practice operating smoothly.

"Having to wait on a computer is a waste of valuable time," he says. "TI runs software fast. And the TI screen has a lot better resolution than other monitors."

His TI 855 printer also speeds up the paperwork. "We can use it to go from draft to letter quality immediately, and change typefaces very quickly by using the control panel instead of software commands."

TI had what the doctor ordered to put together a complete PC system for his specific needs. Including a solution for a budding computer genius in his family. "My daughter," he says, "loves her Speak & Spell."

## TI has the right answers for the way you work.

With TI's broad line of versatile computer products, you can put together a system unique enough to put your own name on it. Your TI dealer can provide you with just the right combination of hardware, software, service and support for your special needs. For more information and the location of your nearest TI dealer, call 1-800-527-3500.

  
**TEXAS  
INSTRUMENTS**  
Creating useful products  
and services for you.



From desktop, portable and briefcase PCs to minicomputers and a full line of printers, you can assemble a TI system as unique as you are.

2775-06  
© 1985 TI



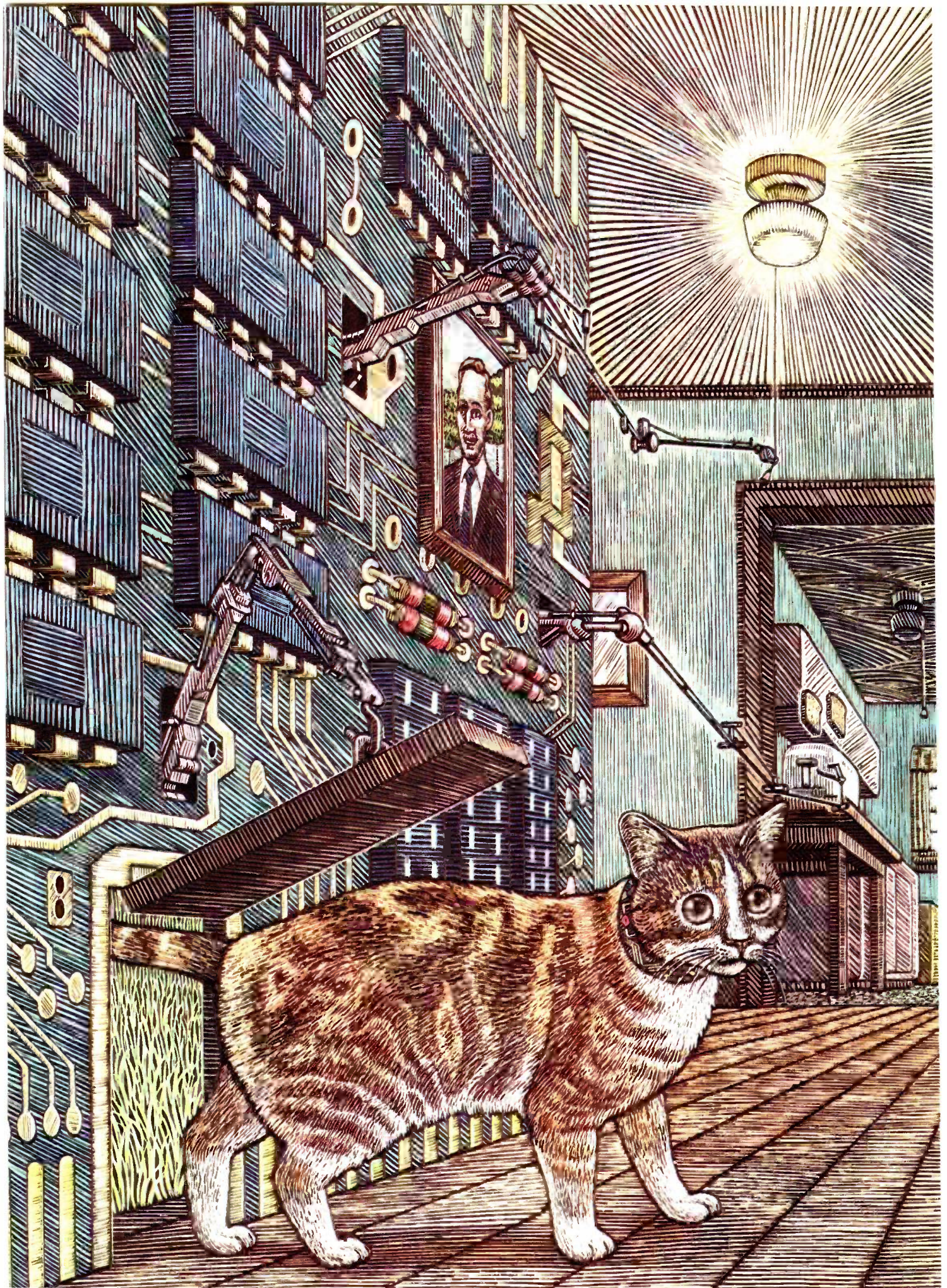



# Features

---

<b>CIARCIA'S CIRCUIT CELLAR: BUILD THE HOME RUN CONTROL SYSTEM, PART 1: INTRODUCTION</b> <i>by Steve Ciarcia</i> .....	102
<b>COPROCESSING IN MODULA-2</b> <i>by Colleen Roe Wilson</i> .....	113
<b>A MILLION-POINT GRAPHICS TABLET</b> <i>by James Hawley</i> .....	120

---

IN JANUARY WE PRESENTED a real feast in the Features department; because we had no theme section, we were able to publish 11 articles on a wide variety of topics. This month, the significance of our theme on artificial intelligence and the depth of coverage it required limited the space we had available for features. Next month we'll return with our usual number.

As we hinted in the March Features introduction, this month Steve Ciarcia begins a three-part project that he's wanted to build for some time. The Circuit Cellar Home Run Control System takes up where Steve's first project of this type left off some years ago (see "Build a Touch Tone Decoder for Remote Control," December 1981, page 42). Imagine full programmable control over just about any outlet in your home. Lights can turn on and off automatically as you enter and leave a room. You can design a complex surveillance and security system that includes automatic emergency dialing. And you can phone home, check system status, and make modifications to the control system to suit your schedule. All in all, Steve was pretty happy with his original 1981 design, but with recent technological advances and his eye for improvement, he developed the Home Run Control System to be a lot friendlier and deliver a lot more.

In August 1984 the BYTE theme was Modula-2. Heralded by many as the language of the future, it also has detractors, some of whom point out that Modula-2 is only an upgrade of its Pascal ancestor with problems of its own. Colleen Roe Wilson's "Coproprocessing in Modula-2" describes Modula-2's facility for the development of concurrent programs, one of its significant differences with Pascal.

If you have a Zenith Z-100 and are interested in exploiting its graphics capabilities, you might want to build "A Million-Point Graphics Tablet" based on Koala Technologies' KoalaPad. James Hawley shows you how to add the appropriate components and interface it to the Z-100's S-100 bus. With his graphics tablet, you can use a stylus instead of a light pen for pinpoint control over your drawings.

—Gene Smarte, *Managing Editor*



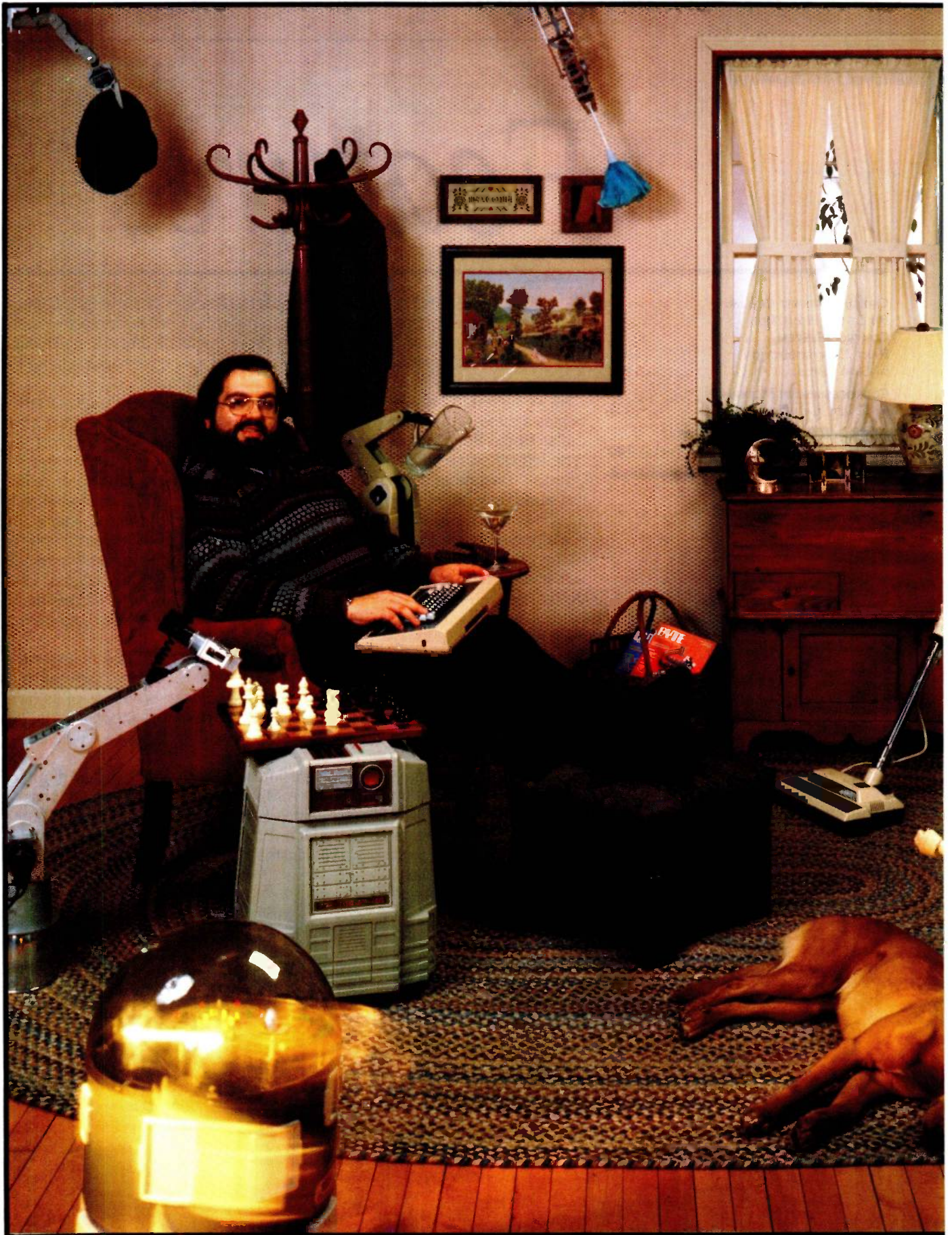



## BUILD THE HOME RUN CONTROL SYSTEM

### PART 1: INTRODUCTION

BY STEVE CIARCIA

*Energy management, convenience,  
and security in one package*



Six years ago I presented an article on building a computer-controlled security system using an SDK-85 experimenters board. To this day, I still get letters asking for software and material sources. Since home/industrial energy and security management have been and still are a major interest (and little has been published since then), that article remains a popular reference for students and experimenters.

As I look back on it now, I realize that my first home-control computer was engineered properly but was about as user-friendly as ENIAC. It's time to re-address the subject, bring the design up to date, and make this home-control system a real friend.

I conceive of this project as a simple computer control system equally applicable in the home or factory. The choice of input sensors and output controls designates its primary application.

Whether for industrial or home use, control systems function similarly. Specific input data is analyzed and compared to a predetermined set of action parameters. If a favorable comparison exists, the designated task is performed. For example, if a light is to be turned on at 2:00 p.m., the control system sees a negative request-affirmation comparison until that time. At that instant, the output of the control system turns on the light and then continues with the next request. In a control system configured as an alarm, the inputs would be from contact closures, and the outputs would be to bells, automatic dialers, and other such items.

Whatever the application, control systems are designed to be either open loop or closed loop in function. An open-loop controller simply outputs its decision and forgets about it. Industrial control systems, on the other hand, require more assurance that the action has been performed. They close the loop by analyzing feedback signals from the operation being controlled. If

*(continued)*

*Steve Ciarcia (pronounced "see-ARE-see-ah") is an electronics engineer and computer consultant with experience in process control, digital design, nuclear instrumentation, and product development. He is the author of several books about electronics. You can write to him at POB 582, Glastonbury, CT 06033.*





a heating element is turned on, a current sensor in series with the element's power source or a temperature sensor next to the element indicates positively that the action has been performed.

It is this open-loop versus closed-loop configuration that, for most applications, defines whether a controller is consumer or industrial quality. I beg to differ with the trend, however, and feel that it is about time a system successfully bridged the gap. The Circuit Cellar Home Run Control System (HCS) is the result.

My intention is not to directly address the industrial market with my HCS. Rather, I will apply some of my industrial process-control experience to produce a design that offers flexibility and reliability as a home-control and energy-management system. If you are in the process-control busi-

ness, you will soon realize that its sophistication and cost-effectiveness make it ideal for dedicated industrial-control applications where you might ordinarily use an expensive programmable controller.

### HOME RUN CONTROL SYSTEM

Practically all commercial home-control systems use BSR X-10 remote-control power modules. They are sold under a variety of trademarks: Plug-N-Power, Sears Home Control, BSR X-10, and GE HomeMinder. These remotely controlled power switches turn the power on or off to lights and appliances that are plugged into them. A separate controller activates the individual switches by transmitting a coded command sequence through the power lines. Command controllers are available that perform timed or telephone-designated activations.

The Plug-N-Power or Sears Home Control system is quite adequate for most open-loop applications. An attic fan that needs to run two hours a day to keep the attic cool could use a timer-activated BSR module. Simply set the command unit to turn the fan on from 1:00 to 3:00 every afternoon, for example. Of course, on really hot days the attic fan will need to run longer, and on rainy days you'll be wasting power. If you compensate (close the loop) by changing the run time each day, it is hardly a home-control system. Instead, it is merely a more convenient manual power switch.

The solution is to use a true closed-loop control. By adding a 120- to 135-degree thermostatic switch in the attic, the control system can know when the attic is hot and has to be exhausted. A 90-degree thermostatic

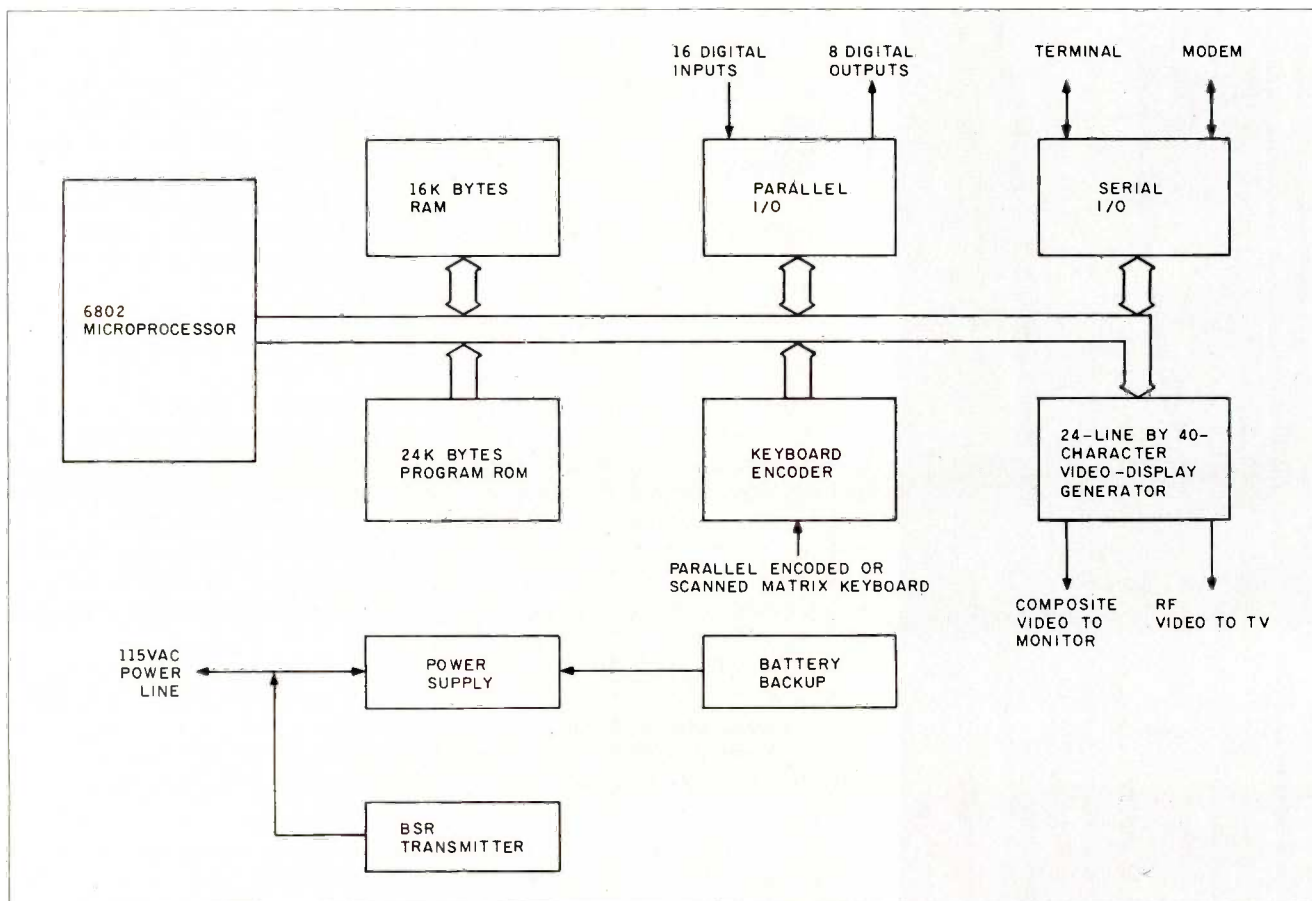

Figure 1: A block diagram of the Circuit Cellar Home Run Control System.



switch is also wired in. When the attic temperature reaches 135 degrees, the fan turns on. It turns off when it gets to 90 degrees. The BSR control modules could still provide the on/off power to the fan, but the control decision is more adequately defined by directly monitoring the temperature with heat sensors than by simple timed activation. This way, the fan will stay on as long and often as needed. On cloudy or rainy days, the fan might not come on at all. (I am aware that special thermostatically controlled attic-fan switches can accomplish this specific task without a computer. I am not trying to find a specific solution but rather to demonstrate the two control approaches as they apply to general-purpose control systems.)

The immediate answer to open-loop BSR control is to add more intelligence in the form of a computer. Presently, many control systems on the market use personal computers. Using the parallel I/O (input/output) and display capabilities of the personal computer with a specialized BSR transmitter card installed, many companies have successfully designed just the kind of home-control system I'd want. However, such a seemingly economical approach uses the entire function of the computer. You can have a \$2500 Apple II home controller or suffer when the entire system grinds to a halt because you've loaded a word-processing program. Besides, it can cost \$10 a month just to run an IBM PC 24 hours a day—and don't forget the cost of the uninterruptible power supply.

Ultimately, successful computer-based energy-management and home-control systems must have completely dedicated functions. Trying to time-share tasks among games, word processing, and environmental control is simply more complicated than it's worth. The age of specialized computers is at hand.

The Circuit Cellar HCS is designed specifically for that task. It is a single-board microprocessor-based controller that uses a combination of both open- and closed-loop control design. It takes advantage of the cost-

effective BSR control modules and fully duplicates any of the manual, automatic, or timed functions presently supported in the BSR product line.

The Circuit Cellar HCS closes the control loop with 16 hard-wired digital input and 8 TTL (transistor-transistor logic)-compatible hard-wired output lines. Relays, contact closures, motion detectors, and thermostatic switches can be connected to these I/O lines for direct "sense and respond" activities. It can also accommodate 48 BSR modules. Figure 1 is a block diagram of the HCS.

The 6802-based HCS is a stand-alone control unit (see photo 1) complete with battery backup. Photo 2 shows the prototype circuit board that

mounts inside the control unit. The HCS communicates with the user through either a serial terminal or video monitor and keyboard. In the terminal mode, RS-232C communication is at 75 to 4800 bits per second (bps).

The HCS optionally supports an integral video-display generator to provide a 24-line by 40-character display either directly to a composite video monitor or to a television set. A keyboard encoder allows connection of either an Apple II-compatible parallel-encoded keyboard or an unencoded scanned-matrix keyboard. Finally, the HCS can communicate with other systems. An additional con-

*(continued)*



Photo 1: Home Run Control System stand-alone control unit.

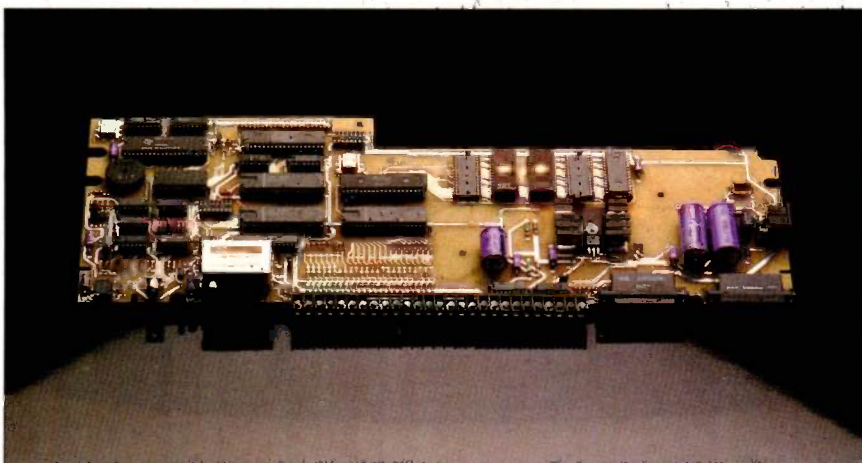

Photo 2: HCS prototype circuit board.



necter has been provided to which an auto-answer modem can be attached (such as the Hayes 300 or 1200). When the modem answers and the

CTS line is activated, the HCS switches its display to the modem data rate and allows the remote calling terminal to access and control the HCS. Unlike

auto-answer BSR units that allow command input only, this option lets you view the complete status of all I/O and make program changes as well.

The HCS can schedule to turn outputs on or off based on combinations of the following conditions:

- a. time of the week (e.g., Tuesday at 4:32)
- b. time of the month (e.g., 22nd at 11:20)
- c. input line going high
- d. input line going low
- e. turn off after time delay (e.g., remain on for 15 minutes)
- f. one-time action triggered by specific input or time

When you want to create an event, various combinations of inputs and time can be specified. They are

1. ON at specified time  
OFF at specified time
2. ON at specified time  
OFF when specified input occurs
3. ON when specified input occurs  
OFF at specified time
4. ON when specified input occurs  
OFF when specified input occurs  
or  
ON while specified input occurs
5. ON when specified input occurs  
OFF after period of time

Lights can be dimmed to one of 16 levels. This allows mood control, night light, or power conservation operation. Text messages of variable size can be scheduled as announcements or reminders. And the HCS uses less than 5 watts (W).

The processor and clock continue to operate during a power failure; scheduled events are noted in memory. When AC power is restored, the HCS restores all modules to the state they would be in if power weren't interrupted.

The on-time of desired modules, usually lights, tracks the sunset. This alleviates having to adjust the schedule many times per year as the sunset changes. Included is a com-

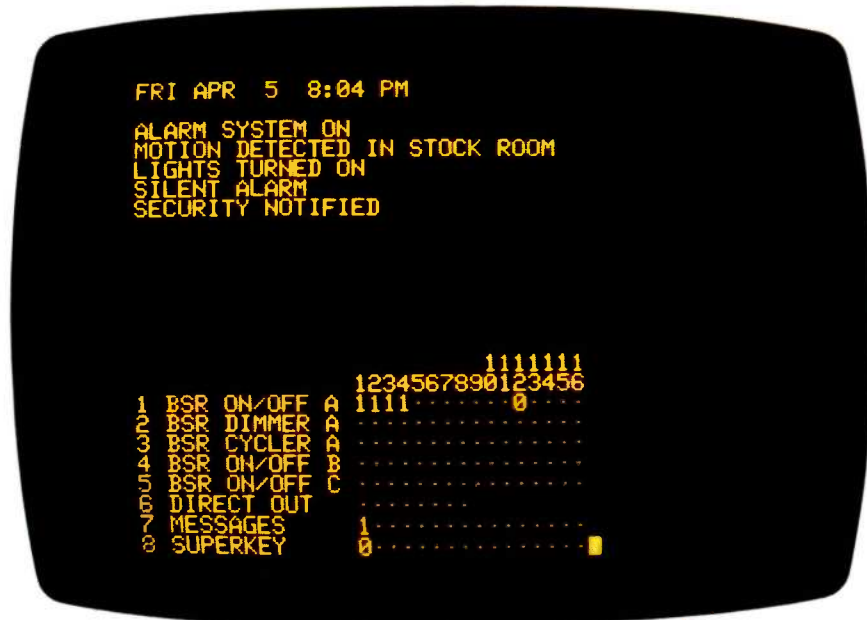

Photo 3: A typical status-display screen. At the top, the screen shows that an alarm has been triggered and that several preprogrammed actions have taken place. The bottom half of the screen indicates the status of all the output drivers.

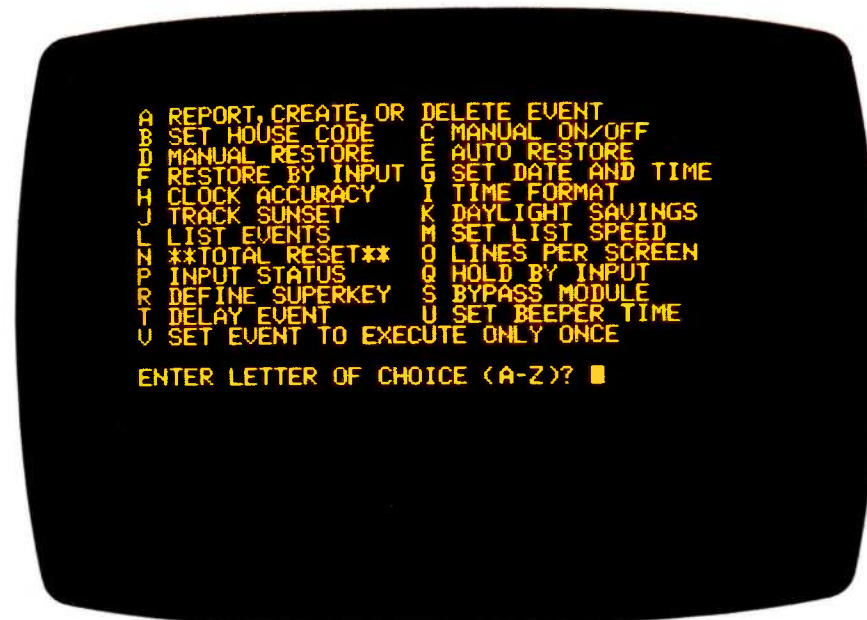

Photo 4: The editing menu. You reach this screen from the status-display screen by pressing the space bar. All the functions will be explained in subsequent articles.



mand to compensate sunset times for daylight saving.

The HCS can optionally restore the status of all modules every four minutes. This is useful in commercial applications where a module may be turned off by a transient or non-HCS-generated command. Restore can also be triggered by an input line.

Modules can be bypassed on a selected interval (up to 44 days). This can be used for vacations or holidays. It also allows an input occurrence to lock out specified modules. Clock accuracy can be adjusted by software to within one second per day. And, finally, the entire event schedule can be listed to the serial port. The speed of the listing can be controlled to allow for printing of the schedule.

The HCS is designed to communicate in English and not in a programming language. All control sequences are prompted through menus, and any input errors simply cause the system to revert back to the status display or the option menu.

The HCS is designed around the concept of an "event." An event has four elements: the type of event, the device on which the event will operate, the trigger that starts the event, and the trigger that ends the event. The type of event is defined in terms of its "driver." These include Message Driver, BSR On/Off Driver, BSR Cycle Driver, BSR Dimmer Driver, Direct Output Driver, and Superkeys.

The Message Driver displays a message on the terminal. The BSR On/Off Driver turns a BSR control module on or off. The BSR Cycle Driver causes a specified BSR module to cycle on and off periodically at a rate determined by the user. The BSR Dimmer Driver changes the brightness of a BSR lamp module. The Direct Output Driver sets the output level on the eight direct output lines. Superkeys are 16 function keys that, when selected by a three-button sequence, trigger a predefined event sequence (such as turning on specific BSR modules, displaying particular messages, or setting specific outputs). The quantity of events is limited only by

(continued)

Figure 2: Programming the HCS to turn the attic fan on.

FRI APR 5 10:09 PM

```

                                1111111
                                1234567890123456
1 BSR ON/OFF A -----
2 BSR DIMMER A -----
3 BSR CYCLER A -----
4 BSR ON/OFF B -----
5 BSR ON/OFF C -----
6 DIRECT OUT -----
7 MESSAGES -----
8 SUPERKEY -----
    
```

(When using a terminal, the raised-dot graphics character is printed as a " - " instead)

(a space entered on the keyboard brings up the editing menu)

```

A REPORT,CREATE,OR DELETE EVENT
B SET HOUSE CODE   C MANUAL ON/OFF
D MANUAL RESTORE  E AUTO RESTORE
F RESTORE BY INPUT G SET DATE AND TIME
H CLOCK ACCURACY  I TIME FORMAT
J TRACK SUNSET    K DAYLIGHT SAVINGS
L LIST EVENTS     M SET LIST SPEED
N **TOTAL RESET** O LINES PER SCREEN
P INPUT STATUS    Q HOLD BY INPUT
R DEFINE SUPERKEY S BYPASS MODULE
T DELAY EVENT
U SET EVENT TO EXECUTE ONLY ONCE
    
```

ENTER LETTER OF CHOICE (A-Z)? A

\* MEANS EVENTS ARE SCHEDULED

```

                                1111111
                                1234567890123456
1 BSR ON/OFF A -----
2 BSR DIMMER A -----
3 BSR CYCLER A -----
4 BSR ON/OFF B -----
5 BSR ON/OFF C -----
6 DIRECT OUT -----
7 MESSAGES -----
8 SUPERKEY -----
    
```

(No events are presently scheduled)

ENTER DRIVER NUMBER (1-8)? 1

ENTER MODULE NUMBER (1-16)? 1

THIS DRIVER/MODULE NOT IN USE

CREATE OR DELETE EVENT (C/D)? C  
374 CHARACTERS AVAILABLE

ENTER NAME OF MODULE

ONE RETURN STARTS NEW LINE  
AND TWO RETURNS ENDS  
?ATTIC FAN

- 1 ON AT SPECIFIED TIME  
OFF AT SPECIFIED TIME
- 2 ON AT SPECIFIED TIME  
OFF WHEN SPECIFIED INPUT OCCURS
- 3 ON WHEN SPECIFIED INPUT OCCURS  
OFF AT SPECIFIED TIME

(continued)



*By selecting  
different options  
you can program  
the HCS to perform  
specific tasks.*

the available RAM (random-access read/write memory). (Even though the Superkeys, messages, and outputs are not BSR devices, I refer to each of their separate events as modules to be consistent with BSR terminology.)

The HCS has two display modes: status and editing. The status display, shown in photo 3, is the normal operating display of the HCS. At the top is the current date and time. Below that is an area where any messages will be displayed when activated. At the bottom is the actual real-time status of all output drivers presented as an 8-driver by 16-module display matrix. If no action has been defined for a particular module, a raised dot is displayed. If an event has been programmed for a particular module, a "0" indicates that it is currently off; a "1" indicates that it is currently on. The display updates in real time as the modules change state or the clock updates.

Pressing the space bar displays the editing menu (see photo 4). By selecting the different options presented in the menu, you can program the HCS to perform the specific tasks you wish. Controlling the attic fan with two thermostatic switches attached to input lines 1 and 2 respectively is a relatively simple procedure. Figure 2 shows what appears on the display screen as we program that event.

The fan will start when input line 1 goes low (it can be redefined for reverse polarity) and will go off when line 2 goes low. Perhaps you want to know when the fan is on (besides remembering that driver 1/module 1 is the fan and looking at the status display), so we'll add a message defined

```

4 ON WHEN SPECIFIED INPUT OCCURS
  OFF WHEN SPECIFIED INPUT OCCURS
(Entering the same input # for
both the ON and OFF trigger
in Item 4 results in "ON WHILE
SPECIFIED INPUT OCCURS")

5 ON WHEN SPECIFIED INPUT OCCURS
  OFF AFTER PERIOD OF TIME

ENTER NUMBER OF ON/OFF
COMBINATION (1-5)? 4

ENTER INPUT # FOR ON (1-16)? 1
ENTER INPUT # FOR OFF (1-16)? 2

ATTIC FAN
  1 INPUT# 1 INPUT# 2

ENTER INPUT # FOR ON (1-16)? (More inputs can be added to specify
the same BSR module function; to exit,
simply enter a return and the status
display will resume)

FRI APR 5 10:11 PM

1111111
1234567890123456
1 BSR ON/OFF A 0-----
2 BSR DIMMER A -----
3 BSR CYCLER A -----
4 BSR ON/OFF B -----
5 BSR ON/OFF C -----
6 DIRECT OUT -----
7 MESSAGES -----
8 SUPERKEY -----
(Status display now
shows driver 1 module
1 programmed but
inactive)

```

Figure 3: Programming the HCS to print a message when the fan is on.

\* MEANS EVENTS ARE SCHEDULED

```

1111111
1234567890123456
1 BSR ON/OFF A *-----
2 BSR DIMMER A -----
3 BSR CYCLER A -----
4 BSR ON/OFF B -----
5 BSR ON/OFF C -----
6 DIRECT OUT -----
7 MESSAGES -----
8 SUPERKEY -----

ENTER DRIVER NUMBER (1-8)? 7
ENTER MODULE NUMBER (1-16)? 1
THIS DRIVER/MODULE NOT IN USE
CREATE OR DELETE EVENT (C/D)? C

1 ON AT SPECIFIED TIME
  OFF AT SPECIFIED TIME

```

(continued)

- 2 ON AT SPECIFIED TIME  
OFF WHEN SPECIFIED INPUT OCCURS
- 3 ON WHEN SPECIFIED INPUT OCCURS  
OFF AT SPECIFIED TIME
- 4 ON WHEN SPECIFIED INPUT OCCURS  
OFF WHEN SPECIFIED INPUT OCCURS
- 5 ON WHEN SPECIFIED INPUT OCCURS  
OFF AFTER PERIOD OF TIME

ENTER NUMBER OF ON/OFF  
COMBINATION (1-5)? 4

ENTER INPUT # FOR ON (1-16)? 1

ENTER INPUT # FOR OFF (1-16)? 2

502 CHARACTERS AVAILABLE

ENTER MESSAGE

ONE RETURN STARTS NEW LINE  
AND TWO RETURNS ENDS  
?

THE ATTIC FAN IS ON

1 INPUT# 1 INPUT# 2

THE ATTIC FAN IS ON

ENTER INPUT # FOR ON (1-16)? (just return to exit)

FRI APR 5 10:12 PM

```

                                1111111
                                1234567890123456
1 BSR ON/OFF A 0-----
2 BSR DIMMER A -----
3 BSR CYCLER A -----
4 BSR ON/OFF B -----
5 BSR ON/OFF C -----
6 DIRECT OUT   -----
7 MESSAGES    0-----
8 SUPERKEY    -----
    
```

(The two zeros indicate that the  
modules are defined but OFF)

(If we close the contact on input line #1, the following happens:)

FRI APR 5 10:15 PM

THE ATTIC FAN IS ON

```

                                1111111
                                1234567890123456
1 BSR ON/OFF A 1-----
2 BSR DIMMER A -----
3 BSR CYCLER A -----
4 BSR ON/OFF B -----
5 BSR ON/OFF C -----
6 DIRECT OUT   -----
7 MESSAGES    1-----
8 SUPERKEY    -----
    
```

(This listing is spaced to show  
the full 24-line display)

*As I use the HCS  
and find certain  
functions or displays  
I want revised, some  
of them may change.*

to trigger from the same events to say "the fan is on."

We can create an event at this point by simply typing "A." The display that results is shown in figure 3.

There is a lot more to this control system than the simple example in figure 3 illustrates. You probably noticed functions such as Restore, Sunset Adjust, Delay, Bypass, and Hold in the editing menu. Eventually, I'll get to explaining them all and illustrating their use.

#### ONE PARTING COMMENT

The HCS is an evolving design. This is a three-month project that is being written over the course of three months. While the hardware design is fixed and printed-circuit boards are checked out, software is constantly evolving and more features are being added. Photos of the menus, status displays, and other items are taken at a specific time in the evolution of the software. As I use the HCS and find certain functions or displays that I want revised, some of them may change.

User-friendliness is one area. In reviewing some of the higher-volume but lower-functioning control systems such as GE's HomeMinder, the emphasis is on graphics and simple user interfacing. If you want to control a lamp on the HomeMinder, you look for the picture of a lamp and manipulate it on the screen.

I configured HCS to be a high-level controller with much less emphasis on pretty graphics. However, many of the professional software people who have seen HCS believe it would have

(continued)



a much wider audience if it had some "paint-by-numbers" appearance. Consequently, they plan to support it independently. A HomeMinder-like graphics package is presently being written for the IBM PC by third parties. It will connect to the HCS through the terminal I/O port. Hopefully, I'll have a picture of it in operation by the third month.

While I'll live without Alice-in-Wonderland control software, I was bitten by the large-system interface bug and decided to take advantage of big-system functions. The HCS optionally includes an upload/download capability to the IBM PC (eventually for other computers). The complete command and control sequence resident in the HCS can be uploaded serially to the PC for storage on disk. A download provision reprograms the HCS with that control sequence.

This storage capability allows the user to run the HCS with various control sequences loaded from disk. A "training" session debugs the sequence and then it is stored on disk for later retrieval. Industrial users who change program sequences frequently are the prime beneficiaries, but new tools often produce new applications. This function is also accessible via the HCS's modem port, and Home Run can be completely reprogrammed by telephone. (Perhaps you have a vacation home. Simply call ahead and let the HCS make it a warm and cozy arrival.)

**EXPERIMENTERS AND OEM USERS**

As always, I try to support the computer experimenter by providing sources for many of the components. The Circuit Cellar Home Run Control System is a single-board design suitable for OEM applications as well. It is available in various configurations that are all ultimately upgradable to the same potential.

If you plan on building the unit from scratch, good luck and take heart. Send me a picture of your board, and I'll send you a free hexadecimal dump (16K bytes) of the control software, provided it is for noncommercial

private use. I'll supply the code on two 2764 EPROMs (erasable programmable read-only memories) and a manual for \$32 (postpaid in the U.S.). Add \$7 for overseas.

**CIRCUIT CELLAR FEEDBACK**

This month's feedback begins on page 408.

**NEXT MONTH**

This is a three-part article. Next month, I'll describe the hardware in detail, hopefully to the extent that you can build your own HCS. The third part will emphasize the software and demonstrate a typical control application. ■

ROBOTIC PROPS (counterclockwise from upper left): 1. **CYBOT INC.**, 12510 128th Ave. NE, Kirkland, WA 98034. 2. **MICROBOT INC.**, 453 Ravendale Dr., Mountain View, CA 94043. 3. **HAIKATO ROBOTICS LTD.**, 1580 Lincoln St., Suite 950, Denver, CO 80203. 4. **HEATH Co.**, Hilltop Rd., St. Joseph, MI 49085. 5. **RB ROBOT CORP.**, 14618 West 6th Ave., Golden, CO 80401. 6. **RSI INC.** (Robotics Systems International Ltd.), 9865 West Saanich Rd., RR2, Sydney, British Columbia V8L 3S1, Canada. 7. **HUBOTICS INC.**, 6352-D Corte Del Abeto, Carlsbad, CA 92008. 8. **RHINO ROBOTS INC.**, POB 4010, Champaign, IL 61820.

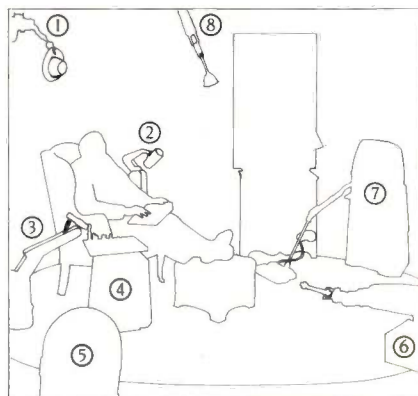

SET PROPS: **STURBRIDGE YANKEE WORKSHOP INC.**, Kettleford Korner, Bedford, NH 03102. **BRITCHES OF CONCORD INC.**, 1 Eagle Square, Concord, NH 03301. **GENIE VACUUM CLEANER CO.**, 93 South Maple St., Manchester, NH 03103.

*Special thanks to Bill Summers and Leo Taylor for their software expertise.*

The following items are available from

The Micromint Inc.  
25 Terrace Dr.  
Vernon, CT 06066  
(800) 635-3355 for orders  
(203) 871-6170 for information

1. Home Run HCS—Complete assembled system with enclosure and Apple-compatible keyboard. . . . . HCS01, \$589
2. Home Run HCS—Populated PC board. Assembled and tested PC board. No enclosure or keyboard. . . . . HCS02, \$429
3. Home Run HCS—Video-based kit. Includes PC board and all components except enclosure, keyboard, and serial-interface components (IC16, IC17, IC20, and two DB-25 connectors). . . . . HCSV05, \$329
4. Home Run HCS—Terminal-based kit. Includes PC board and all components except video-display processor (IC22, IC25, and IC26). No keyboard, enclosure, or RF modulator. . . . . HCST06, \$289
5. 8K-byte static-RAM upgrade. Increases RAM to 16K bytes. . . . . HCS20, \$35
6. Apple II-compatible ASCII-encoded keyboard. . . . . HCS21, \$79
7. Wall transformer/transmitter module (available separately). . . . . HCS22, \$40

All kits and assembled units include operators manual, power supply with wall transformer/transmitter module, and 8K bytes of RAM. All units are supplied without keyboard encoder chip (not necessary when using encoded keyboard, IC18—optionally available). All item numbers that list enclosures also include backup battery holder (6 "C" cells), less batteries. Serial-port and video-display-processor upgrades for items 3 and 4 and various other components are also available.

Please include \$8 for shipping and handling in the continental United States, \$12 elsewhere. New York residents please include 8 percent sales tax. Connecticut residents please include 7.5 percent sales tax.

**Editor's Note:** Steve often refers to previous Circuit Cellar articles. Most of these past articles are available in book form from BYTE Books, McGraw-Hill Book Company, POB 400, Hightstown, NJ 08250.

*Ciarcia's Circuit Cellar, Volume I* covers articles in BYTE from September 1977 through November 1978. *Volume II* covers December 1978 through June 1980. *Volume III* covers July 1980 through December 1981. *Volume IV* covers January 1982 through June 1983.

To receive a complete list of Ciarcia's Circuit Cellar project kits, circle 100 on the reader-service inquiry card at the back of the magazine.

# The new HERCULES Color Card gives you the parallel port IBM forgot-for \$1 more.

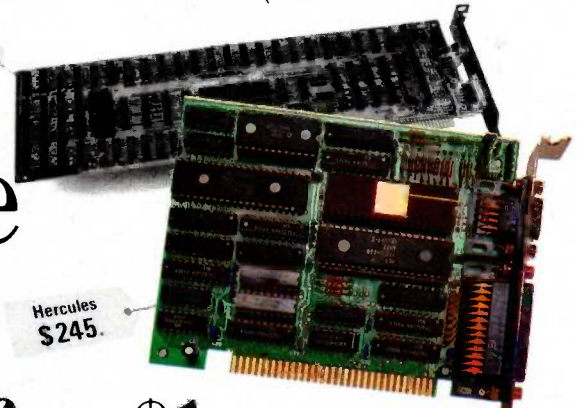

The new Hercules Color Card gives you these five important features in a color graphics card.

1. Full IBM color card compatibility.<sup>1</sup> Any program that runs on IBM's color card will run on the new Hercules Color Card at the same resolution.

2. A parallel printer port—standard on the Hercules Color Card, but forgotten by IBM on theirs.

3. It's short. The pint-sized Hercules Color Card fits in the short slot in an XT or *Portable*.<sup>2</sup> And it's AT™ compatible.

4. It can work in your system at the same time as the famous high resolution Hercules Graphics Card.<sup>3</sup> And it will continue to work backed by our 2 year warranty.

5. Low price. At a suggested list price of \$245, the Hercules Color Card is only \$1 more than IBM's card.<sup>4</sup> And our Graphics Pak™ saves you even more money when you buy both Hercules cards at the same time.

Call 1 800 532-0600 Ext 432 for the name of the Hercules dealer nearest you. See why the company that made the first graphics cards for the IBM PC still makes the best.

	IBM Mono Display Compatible	IBM Color Display Compatible	Hi-Res Text	720 × 348 Hi-Res Graphics	320 × 200 Color Graphics	640 × 200 B&W Graphics	Parallel Printer Port
Hercules Color Card		•			•	•	•
Hercules Graphics Card	•		•	•			•
IBM Mono Card	•		•				•
IBM Color Card		•			•	•	

**Hercules.  
We're strong  
on graphics.**

Address: Hercules, 2550 Ninth St. Berkeley, CA 94710 Ph:415 540-6000 Telex:75-1063 Foreign distributors: Compuserve/Canada; Reflex/U.K.; Computer 2000/W. Germany; Edisoft/France; Imagineering/Australia; Holland Info Products/Holland; DataTeam/Scandinavia Trademarks/Owners: Hercules, Graphics Pak/Hercules Computer Technology; IBM, AT/ International Business Machines Notes: (1) An adapter is supplied for composite video. (2) The IBM Color/Graphics Monitor Adapter must be removed from the *Portable* before the Hercules Color Card is installed. (3) Model GB101 or later. (4) Based on the list price as of 7.1.84 for the IBM Color/Graphics Monitor Adapter.



*Imagine  
dBASE III™  
running up  
to 20 times  
faster.*

*The time  
for Clipper  
has arrived.*



## *Clipper introduces you to the time of your life.*

Time is your most valuable commodity. Because how you spend your time, is how you live your life.

At Nantucket, we believe you should live life to the fullest.

Clipper, the first true compiler for dBASE III™ is a timely example. Now, dBASE compiled by Clipper runs 2 to 20 times faster than dBASE with its standard interpreter.

A dBASE interpreter painstakingly checks and executes your source code one line at

a time, every time you run a program. With Clipper, once you've debugged your source code, it's compiled into more efficient machine code. Your program runs without the time consuming overhead of redundant translation. Clipper compiles all your existing and future dBASE III programs.

Developing a compiler for dBASE III was just a matter of time. Call your dealer or our toll free 800 number and ask for Clipper.

Then go make the most of your life time.



nantucket

# COPROCESSING IN MODULA-2

*The key to writing  
concurrent programs  
is coordination*

One of the main differences between Modula-2 and its ancestor, Pascal, is that Modula-2 contains specific programming constructs to permit the development of real-time concurrent programs. Thus, you can use Modula-2 to write operating systems and other low-level software instead of using assembly language, the language in which operating systems are traditionally written.

## CONCURRENCY

Truly concurrent programs execute at exactly the same instant in time—implying the use of separate computers. True concurrency occurs in

distributed processors such as those found in control systems and other real-time applications.

When several people use a single computer, however, concurrency refers to interleaved execution. Such programming is at the heart of large time-sharing systems, where many users on a single computer can run programs at the same time. Each person perceives only the execution of his own program, while the operating system performs a juggling act partitioning the processing power among the users. Interleaved execution, then, is the seeming concurrency of many processes running on one processor.

Whether we call it true concurrency or not, the problems inherent in writing this type of program are much the same. The main problem is timing. Concurrent programs must deal with nondeterministic events that occur at arbitrary times.

Suppose you have two computers connected by some kind of communications link. You want to write a program so that two people sitting in two different places can exchange messages by typing at their respective keyboards. Each computer must perform this basic sequence of actions:

- When a key is struck on computer A's keyboard, A must retrieve that key's value and send it to computer B.
- When a character arrives at computer A from computer B, A must

*(continued)*

Colleen Roe Wilson (RR 1, Campbellville, Ontario L0P 1B0, Canada) is a member of the technical staff at Allied Canada in Mississauga, Ontario. She has a B.S. and an M.S. in mathematics and enjoys gourmet cooking, gardening, and hiking.

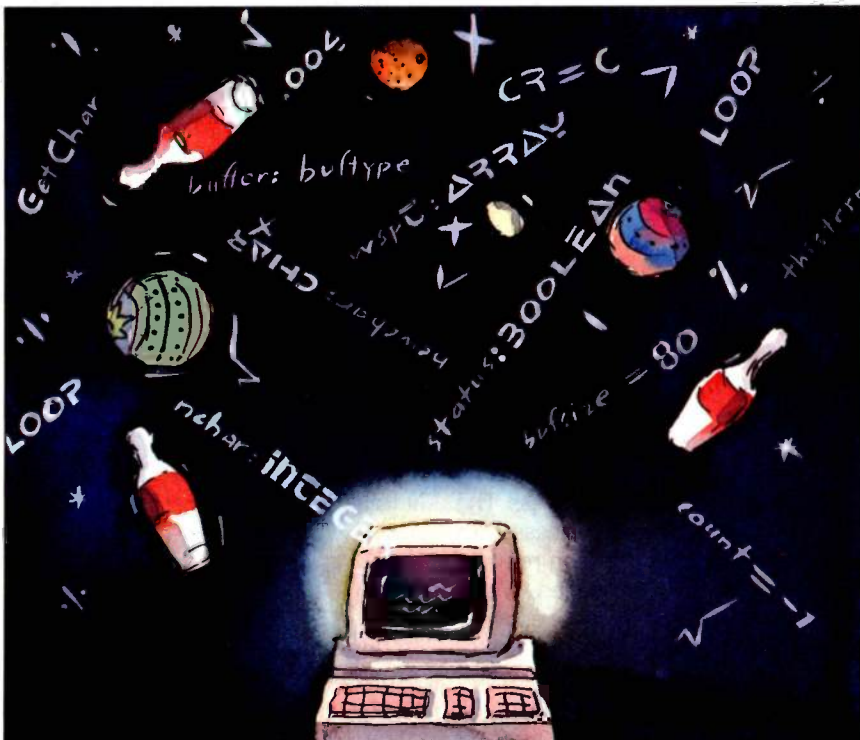



display it in the next free position on its screen.

Does this sound simple enough? Let's take a look at what can happen. If you stop and think about how you type at a keyboard, it becomes obvious that you can't expect a fixed pattern to the keyboard input and the arrival of data on the link. Two users might carry on a question-and-answer conversation so that only one person types at a time. On the other hand, two users might argue and type simultaneously. Either way, the program needs to know what to do. This nondeterministic activity differentiates real-time programs from typical application programs with fixed read/write interfaces. You can't predict how many reads (input from the keyboard) or writes (output to the link) the program will have to deal with or how they will be ordered.

The nondeterministic nature of concurrent programming leads to some interesting problems—deadlock or "deadly embrace" being the best known. Suppose a time-sharing system is trying to run two programs. Both programs need exclusive use of the computer's tape drive and a particular printer to run. The operating system starts program A, which acquires the tape drive. Having used its time slot, program A is suspended while the operating system starts program B. Program B immediately acquires the printer and is suspended. When A starts up again, it attempts to acquire the printer and fails, so its execution is suspended until the printer is freed. When B starts up again, it attempts to acquire the tape drive and is likewise suspended until the drive is freed. The two programs are deadlocked. Neither can proceed until the other frees the resource needed.

The key to writing successful concurrent programs is coordination. You must make sure that programs that are either cooperatively or independently executing interact with each other in a constructive—or at least nondestructive—manner. Modula-2 has programming constructs dealing

with concurrency to aid in this coordination.

### COPROCESSES

Coprocessing is a technique that helps you implement coordination when writing concurrent programs. For example, suppose you write two programs to execute as coprocesses—Text and Disk. Text prompts you to enter text from the keyboard for disk storage (it could be an editor). Disk is a low-level driver program that interacts with the disk to read and write records. The two coprocesses interact as follows:

- Text prompts you for keyboard input and puts the characters into a buffer as it receives them until it finds the record terminator.
- Text signals Disk that a record is ready in the buffer and suspends execution.
- Disk retrieves the record and writes it to the disk.
- Disk signals Text that the record has been written and suspends its execution.
- Text resumes execution at the point of suspension and prompts you for more input.

Thus, Text and Disk coprocess the information by passing it back and forth. This producer(Text)/consumer(Disk) relationship is the classic relationship between coprocesses.

You can expand this concept to include more than two processes. Suppose you want various processes to exchange messages during execution. They need to be able to send messages to other processes and to receive the same—a sort of electronic interprocess mail scheme. One special process is the postmaster. It receives and stores messages and then distributes them as requested by the designated receiving process. The postmaster acts as a coprocess with the other processes that can request to send or receive messages. When sending, the requesting process suspends execution while the postmaster picks up the message in its buffer and resumes when the postmaster is done. When receiving, the requesting

process suspends while the postmaster fills its buffer with the message and then continues.

### WRITING COPROCESSES IN MODULA-2

Two essential mechanisms are needed to implement the mechanics of coprocessing: first, a means of identifying and executing a program that establishes it as a process; second, a method so that two coprocesses can signal each other to coordinate their activities. Modula-2 has facilities for these mechanisms imbedded within it. Modula-2 programmers do not have to get around the language to write coprocesses; the language directly supports this kind of programming.

The most fundamental support of coprocesses provided in Modula-2 is the data type PROCESS, which can be imported from the module SYSTEM. We expect languages to support our abstract number systems with such data types as REAL and INTEGER, but this is something new: a process materialized in a data type. The need for it is obvious: a language that manipulates processes must be able to refer to them in a concrete manner.

Coprocesses use these PROCESS variables to communicate with each other. Therefore, when you create a coprocess, you must bind it to one of these variables. Likewise, when these programs pass control to one another, they must use PROCESS variables to indicate their targets. Modula-2 contains two procedures that provide this control: NEWPROCESS and TRANSFER, both of which are imported from the module SYSTEM.

NEWPROCESS, which creates a coprocess within the system and binds it to a PROCESS variable, is called by

```
NEWPROCESS(p: PROC,a:  
ADDRESS,s: CARDINAL,VAR c:  
PROCESS);
```

In this statement, *p* is the name of a procedure that contains the code you want to constitute the process, *a* is the

(continued)





## Combine VISION with PC Graphics



**Captures  
Anything You Can See.**

**IMIGIT adds icon-  
selected Graphic  
Functions, text, and  
textures with a full  
palette of vibrant colors.**

**Together You Enjoy  
Unparalleled Economy  
and Applications  
Flexibility.**



*The illustration incorporates line art, photos, text, textures and color elements. You can do the same with this icon-driven, user-friendly system.*

For \$695.00 you get the PC-EYE™ video digitizer board and IMIGIT™ graphics software. PC-EYE allows you to capture real-life images with an ordinary video camera or VCR and produce them on your personal computer. IMIGIT is an icon-oriented graphics software package which allows you to modify the camera image by adding text, patterns, colors, lines and shapes. By using cut and paste features with multiple video images, you can store images for later retrieval and print images from the screen.

You get this Exciting Tool for integrating video images with graphics created by other software packages like Lotus 1-2-3\*, Graftalk\*, CAD and business presentation packages. Imagine combining a real-life camera image, text and a pie chart generated by Lotus into one picture. It's really as easy as 1, 2, 3.

### IMIGIT Supports . . .

High Resolution - up to 640 x 512 pixels with 16 colors or gray scale (64 with 6-bit PC-EYE). Flexibility - to support the most popular graphics cards and printers for convenient display and hardcopy output. Speed - less than 2/10 of a second to capture an image in the IBM-compatible 320 x 200 mode. All in all, a powerful but easy-to-use package that allows you to develop sophisticated and dramatic graphic presentations.



**CHORUS is the Single Source** for your graphics and imaging needs. Complete solutions in both hardware and software. Call us for other low cost/high performance imaging products such as Dr. Halo\* and Halo\* graphics software; video cameras and accessories; and graphic adapter cards. You can expect prompt delivery, technical support and complete OEM design assistance.

**CALL 1-800 OCHORUS or  
603-424-2900.**

*PC-EYE and IMIGIT are trademarks of  
Chorus Data Systems, Inc.*

\*Dr. Halo and Halo are trademarks of Media Cybernetics, Inc.  
Graftalk is a trademark of Redding Group, Inc.  
Lotus 1-2-3 is a trademark of Lotus Development Corporation.  
Inquiry 66

# CHORUS



address of a storage area that serves as the working space for the process (local data and context are stored in it), *s* is the size of the working space, and *c* is a PROCESS variable that NEWPROCESS sets to the value of the coprocess it creates.

TRANSFER is the procedure that transfers control from the calling coprocess to the one called. It is invoked by

```
TRANSFER(VAR
  thisprocess,coprocess:
  PROCESS);
```

When a TRANSFER takes place, the calling coprocess is suspended and its context (data values, current program counter, etc.) saved. When the called coprocess executes the reverse TRANSFER, the calling program resumes execution at the point immediately following its just-executed TRANSFER statement. This is the significant difference between procedural calls and TRANSFERs. Each time you call a procedure, execution returns to the beginning of the program and local storage is reallocated. Coprocesses maintain context between TRANSFERs.

The actual implementation of the data type PROCESS and the procedures NEWPROCESS and TRANSFER varies with each machine and compiler. However, you need not be concerned with this. The data abstraction provided by Modula-2 lets you merely manipulate the PROCESS variables with these procedures. Your interface is constant across machines. Contrast this with assembly-language programming, where you need significant knowledge of the operating-system internals to manipulate the data structures representing processes.

### CODING AN EXAMPLE

Now that we've established what facilities exist in Modula-2 to program coprocesses, let's look at an example. Starting at the top of the module definition of TermHandler (see listing 1), you import the needed concurrency structures from SYSTEM: the data types PROCESS, ADDRESS, and WORD, and the procedures NEW-

Listing 1: An example of coprocesses coded in Modula-2.

```
MODULE TermHandler;
  FROM SYSTEM IMPORT ADDRESS, PROCESS, NEWPROCESS, TRANSFER,
    WORD, ADR, SIZE;
  FROM SYSIO IMPORT GetChar, PutDisk;
  CONST bufsize = 80;
    nterm = 16;
    CR = 13C;
  TYPE buftype = ARRAY[0..bufsize - 1] OF CHAR;
  VAR buffer: buftype;
    nchar: INTEGER;
    wspT: ARRAY[0..nterm - 1],[1..200] OF WORD;
    wspD: ARRAY[1..200] OF WORD;
    D,C: PROCESS;
    T: ARRAY[0..nterm - 1] OF PROCESS;
    thisterm: INTEGER;
  PROCEDURE TextIn;
    VAR newchar: CHAR;
      status: BOOLEAN;
      localbuf: buftype;
      count: INTEGER;
  BEGIN
    count = - 1;
  LOOP
    GetChar(thisterm,newchar,status);
    IF status THEN
      CASE newchar OF
        CR: nchar = count;
          buffer = localbuf;
          TRANSFER(T[thisterm],D);
          count = - 1
        ELSE
          INC(count);
          localbuf[nchar] = newchar;
          IF count = bufsize - 1
            THEN
              nchar = count;
              buffer = localbuf;
              TRANSFER(T[thisterm],D);
              count = - 1
            END
          END
        END;
      TRANSFER(T[thisterm],C)
    END;
  END TextIn;
  PROCEDURE TextToDisk;
  BEGIN
  LOOP
    PutDisk(buffer,nchar);
    TRANSFER(D,T[thisterm])
  END
  END TextToDisk;
  BEGIN
    NEWPROCESS(TextToDisk,ADR(wspD),SIZE(wspD),D);
    FOR thisterm = 0 TO nterm - 1 DO
      NEWPROCESS(TextIn,ADR(wspT[thisterm]),
        SIZE(wspT[thisterm]),T[thisterm])
```

(continued)

## COPROCESSING IN MODULA-2

```

END;
thisterm: = 0;
LOOP
  TRANSFER(C, T[thisterm]);
  thisterm: = thisterm + 1 MOD nterm
END
END TermHandler.
    
```

PROCESS, TRANSFER, ADR, and SIZE. ADDRESS and WORD are self-explanatory primitive data types, ADR is a function that returns the initial address of the variable passed to it, and SIZE is a function that returns that variable's storage allocation size. Assume the existence of a module named SYSIO, from which you import GetChar and PutDisk. In the CONST section you define the buffer size (bufsize) and the record terminator CR (carriage return). In the VAR section you define the shared buffer (buffer) and the shared character count (nchar). In addition, you define working spaces for the two coprocesses you will create (wspT and wspD).

Suppose you want to handle keyboard-to-disk transfers for a number of terminals—an order-entry system, for example. Listing 1 shows an array of processes (T) and working spaces (wspT). The procedure GetChar is passed a terminal-port number (thisterm) and returns a status (true means new character returned while false means the opposite) as well as the keyboard character (newchar). If a character has arrived since the last GetChar call, it is returned; otherwise the status reports the failure. The reason will become clear in a moment.

As the main body of code for TermHandler begins, process D is created, followed by the nterm terminal processes. Then the program enters a loop continually coprocessing with each of the individual terminal handlers. Each one manages its own character count (count) and buffer (localbuf). When a handler detects a CR or a full buffer, it moves its own buffer and count to the global buffer (buffer) and global count (nchar) and transfers to process D to dump the record. (Although it is more common for coprocesses to share pointers to

variables than actual variables, these examples use them to make the code more readable.) You can see that if GetChar waited for a character to arrive—in other words, if it did not use the status—a single terminal could hold up all the others if it produced no input.

What does coprocessing achieve in this example? First, when a specific terminal handler issues a TRANSFER back to process C, its context is saved in its workspace. Therefore, the next time it is activated, the values of count and localbuf are appropriately set. This would not be true if you used procedural calls instead of coprocesses.

Second, because each handler maintains its own data structures, the overall program is kept fairly simple. You don't have to manage an array of buffers and counters. Each handler is concerned with only a single buffer and counter, and the code is recycled nterm times. You also gain flexibility. A more sophisticated version of TermHandler could associate processing priorities with some terminals and choose to ignore others. In fact, in a coprocessing situation TermHandler could create new terminal handlers on request (instead of using a fixed number) or only transfer to a specific handler on certain conditions.

### CONCLUSION

Coprocesses cooperatively process information by interleaved execution on a single computer. You must be careful to ensure that processes interact constructively, and Modula-2 automatically contains the programming constructs to aid in this coordination. These coprocesses provide a means of passing control between programs without losing the desired execution sequence or the context. ■

**\*FREE 3M  
Flip 'n' File™  
Offer...**

One less  
thing to  
worry  
about.™



### Lifetime Warranty

SS-DD **\$1.52\*** 5 1/4 QTY. 20 **\$2.05** DS-DD  
~~\$2.25~~ ← 96 TPI → ~~\$2.84~~  
~~\$2.80~~ ← 3-5" SS-135 TPI  
 \*With FREE 3M Flip 'n' File

If it's worth remembering, it's worth Scotch. Factory fresh and prepacked with 10-5 1/4" 3M diskettes in 3M Flip 'n' File. Includes Tyvek envelopes, reinforced hubs, user ID labels and write-protect tabs.

### Special Bonus Offer

As an introductory offer, for every box of 3M-5 1/4" diskettes you order you get FREE, 3M's new Flip 'n' File™. 50% more storage capacity, sturdy and with compact design that swings open to an easel-type work station in one quick motion. A moveable front panel and see-through window in front and back feature index cards. Holds very comfortably 15-5 1/4" diskettes. From a tradition of excellence—now comes disk storage. A \$10.00 value is offered free of charge while supply lasts.

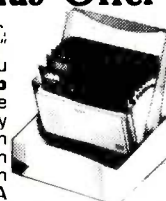

### 3M Headcleaning Kit

Without disassembly or mess, without abrasion worries. 3M Headcleaning Kit has everything you need for 10 headcleaning operations. **\$7.95**

### Disk Storage

Amaray Media Mate 50 (Holds 50-5 1/4" diskettes) ... **\$9.95**  
  
 Disk Minder II-75 (Holds over 75 5 1/4" diskettes) ... **\$11.95**  
 Micro Disk Minder 36 (Holds 36-3 1/2" micro diskettes) ... **\$8.75**

PRINTER RIBBONS	EA.	DZ.
Epson MX-70/80 .....	<del>\$3.53</del>	<b>\$4.00</b>
Epson MX-100 .....	<del>\$4.90</del>	<b>\$5.55</b>
Okidata-80/82/83/92 .....	<del>\$1.45</del>	<b>\$1.71</b>
Okidata-84 .....	<del>\$3.50</del>	<b>\$4.11</b>

### Price Promise

We will better any lower delivered price on the same products and quantities advertised nationally!

**TERMS:** FREE USE OF VISA & MASTERCARD. American Express also accepted. COD orders add \$3.00 handling charge. **Shipping:** Add \$3.00 per 100 diskettes or fraction thereof. **Other Items:** Add \$2.00 for disk storage or headcleaning kit or each multiple of 8 ribbons. P.O. accepted. Utah residents add 5% sales tax. Minimum order \$30.00.

**TOLL FREE ORDER LINE:**  
**1-800-233-2477**  
**(1-800-AFFAIRS)**  
**INFORMATION AND INQUIRIES:**  
**1-800-942-6717**  
 HOURS: 9AM - 5 PM M-F (MT. STATE TIME)





Scrolling down Fifth Avenue.





Step beyond the limits of personal computing, and through the doors of the world's finest stores. Or right into the action on Wall Street. Browse, buy, sell or trade. Stocks, information, Maine lobster, Oregon seedlings, Italian luggage, airline tickets. Without leaving your chair.

With an Avatex™ modem, your personal computer can take you wherever you want to go, on your schedule. As far, as fast, as often as you like, at a price that won't stop you in your tracks.

Avatex gives you the power, speed and intelligence of a serious piece of communications equipment, streamlined so anyone can use it easily and productively. Immediately.

So with Avatex the possibilities are astronomical, but the price of owning one is not: Avatex 300—\$64.95\*, Avatex 600—\$99.95\*, Avatex 1200—\$299.95\*

For the name of the Avatex dealer nearest you, call 800-4-AVATEX.

## *Avatex™ Modems*

*The next step in personal computing.*



Avatex™ is a trademark of E+E DataComm. U.L. C.S.A. & FCC Part 15 and 68 approved. Copyright 1985 by E+E DataComm. \*Suggested retail price.



BY JAMES HAWLEY

# A MILLION-POINT GRAPHICS TABLET

## How to build low-cost graphics for the Z-100

The following is a list of the parts used in this project and the price paid for each. This project can be built for less than \$180.

1 KoalaPad.....	\$99.00
1 S-100 Proto card.....	15.00
2 ADC1001 A/D converter ICs*.....	60.00
2 20-pin sockets.....	.50
2 14-pin sockets.....	.50
1 16-pin socket.....	.25
1 74LS20 dual 4 input nand.....	.50
1 74LS04 hexadecimal inverter.....	.50
1 7805 +5-volt regulator.....	.75
1 100- $\mu$ F capacitor.....	.50
1/4-watt resistors:.....	1.00
2 10k ohm	
1 8.2k ohm	
1 1.5k ohm	
1 330 ohm	

\$178.50

\* available from: **DIGI-KEY**  
Highway 32 South  
POB 677  
Thief River Falls,  
MN 56701  
(800) 346-5144

**T**he need for a graphics tablet is quickly apparent if you try to do high-resolution drawings from a keyboard. Although you can create complex pictures with the control keys and cursor, you will soon want a true drawing machine because of the directional and speed limitations of keyboard drawing.

The Zenith Z-100 is truly a graphics computer with 640 by 225 pixels in three planes (eight colors). The machine devotes 64K bytes to each plane and has the ability to create 640 by 480 pixels in eight colors. The ZBASIC graphics commands offer a quick method of creating custom graphics programs.

To attain true graphic creativity you need to use a stylus for input. You can draw with a light pen but it is often awkward to use vertically and difficult to tell exactly where the pen is pointing on a pixel-by-pixel basis. A graphics tablet solves these problems.

There are many methods of interfacing analog input to a microcomputer's bus but it is simplified by

*James Hawley (4272 Queens Ave. South, Minneapolis, MN 55410) is the president of Laminar Flow Inc. in Minneapolis. He enjoys flying gliders and designing computer-graphics hardware and software.*

bus-compatible analog-to-digital (A/D) converters. The National Semiconductor ADC1001 enables you to interface a 10-bit digital (1024-point) signal to the Zenith S-100 bus with only two support chips.

The graphics pad described here uses Koala Technologies' KoalaPad for the analog  $x, y$  input that feeds the two ADC1001s connected to the S-100 bus. To modify the KoalaPad, you open it by unscrewing the screws on the bottom, holding the unit together and flipping it over, and then lifting the pad away from the circuit board. Remove the black and blue wires from the bottom of the board and, with wire-wrap wire, solder them onto pins 4 and 9 (respectively) of the chip on the lower left side of the circuit board (next to resistor number 23). These two lines will now carry the 0-3-volt analog signal (see photo 1). Tape the wires out of the way and gently replace the pad. Then put on the cover, turn the unit over, and screw it back together. The KoalaPad is now ready to plug into the empty socket on the S-100 card. A brief description of the circuit is shown in figure 1. You can use the wire-wrap wire-and-solder method to build the board but the 3M press-pin method is easier. It allows rapid assembly and disassembly. The 3M socket and insertion tool make up

the 3M wiring system, which is sold as the Whiz Kit by Ragon Inc. of Minneapolis, Minnesota. Its ease and speed justify the high cost of the sockets.

Listing 1 gives you all the programming necessary to get the  $x, y$  values you need for drawing or cursor movement from the circuit board. If you intend to compile the program, it is a good idea to repeat the OUT and INP routines and compare the values you get. This error checking is helpful because the KoalaPad can generate some bogus values because of the execution speed of compiled code.

If the ZBASIC language were changed to take full advantage of the interface mode, then Zenith would be able to offer true high-resolution color graphics at the lowest price in the industry. ■

**Listing 1:** This program is all you need to access the KoalaPad.

```

10 'LISTING #1
20 OUT 1270 'START CONVERSION
30 A = INP(127) 'INPORT TOP 8 BITS
40 B = INP(127) 'IN BOTTOM 2 BITS
50 A = A*4:B = B/64:X = A + B '10 BITS
60 OUT 1260 'START CONVERSION
70 A = INP(126) 'INPORT TOP 8 BITS
80 B = INP(126) 'IN BOTTOM 2 BITS
90 A = A*4:B = B/64:Y = (A + B)/4

```

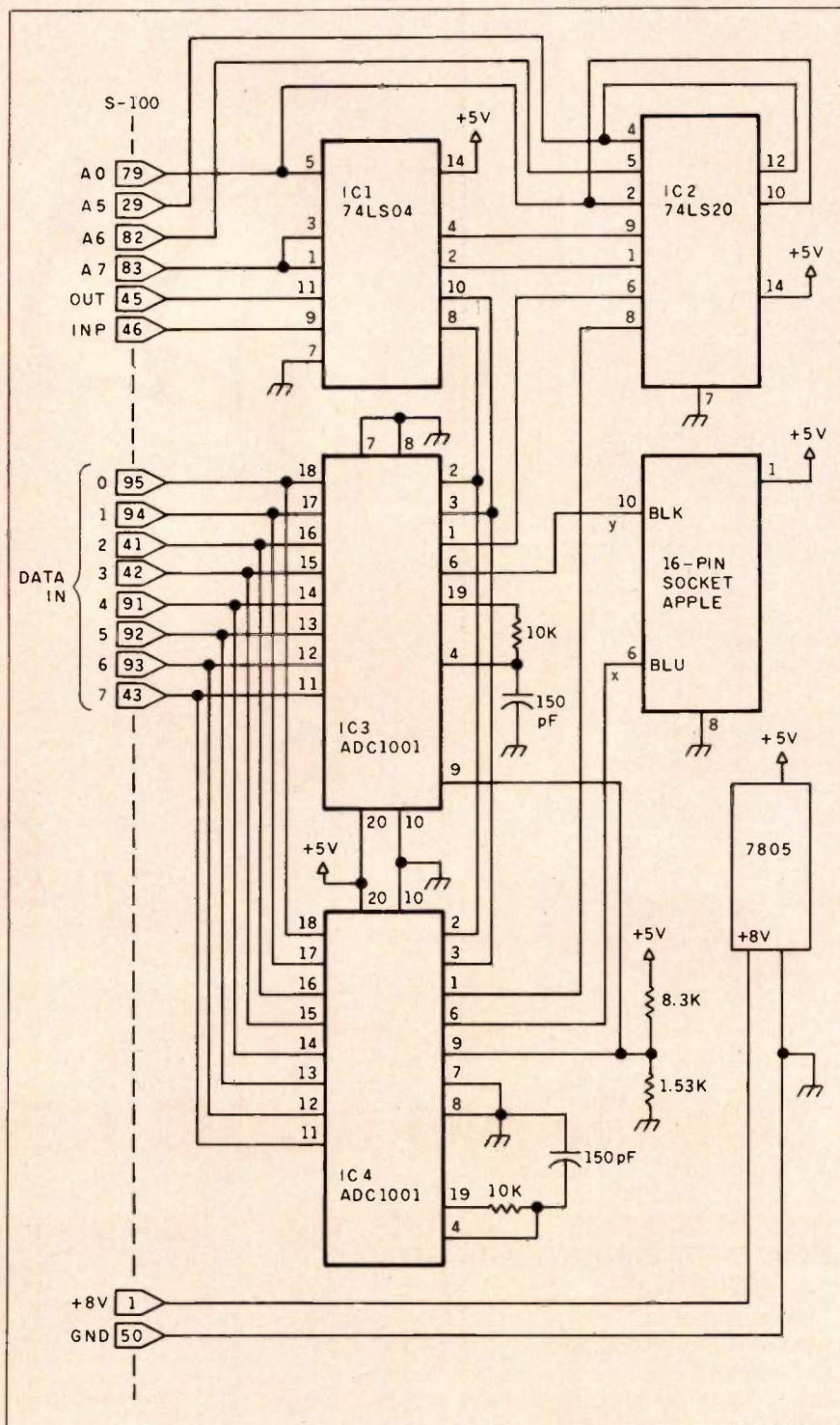

**Figure 1:** The 74LS04 inverts address signals to the 74LS20 to create two chip-select signals for the two ADC1001s (U3 and U4). It also inverts the OUT and INP lines and sends their signals to U3 and U4 as  $\overline{WR}$  and  $\overline{RD}$ . The clocks on pins 19 and 4 of the ADC1001s use a resistor capacitor circuit, and reference voltage for the circuit comes from resistors across GRD and +5.



# THE ADVENTURE CONTINUES . . .



**\$49<sup>95</sup>**

## SOMETHING BRAND NEW

**INSTANT DATABASES . . . BECAUSE THAT'S HOW MOST OF US NEED INFORMATION . . . INSTANTLY!**

Homebase provides you instant access to a whole realm of databases. Just hit the hotkey to freeze whatever software you're working in, and you're ready to find, insert or manipulate data.

This is much more than a simple cardfile or mini-database. You'll be able to set up your own templates, define parameters such as the length of a field, and do rapid key searches. You can have thousands of records in a database. And numerous databases on your menu.

## THE TOOLS YOU NEED.

We've included a powerful set of tools that will save you time and help you organize information, schedule, calculate and a whole lot more. All within a quick keystroke . . . regardless of the software you're running!

You may find a few of these in some "desktop" products . . . but nothing else approaches the power of Homebase!

- Instant Databases
- Phone Message Pad
- Rolodex™
- Appointment Calendar
- Calculator
- Notepad
- Time and Expense Diary
- Programmable Hotkey (You choose the key that gets you to your Homebase)
- Electronic Mail (as an automatic multi-task)
- Tables and Pages (for those things you always need to look up)
- Alarm Clock (including Musical Snooze Alarm)
- To-Do List
- Quickterm Terminal (available even when you're working in another program)
- Autodialer
- Template Maker (for designing your own databases)
- DOS Services
- Rolodex Card Printer
- Mailing Label Printer
- Data Transfer (between databases or your other software)
- Cut and Paste (great for putting together an Electronic Mail letter that combines a chunk of spreadsheet, some text from a document, and a few notes)



# THE EXCITEMENT IS BACK

With the Electronic Mailbag of Your Dreams

ELECTRONIC MAIL THAT TAKES CARE OF ITSELF . . . IN THE BACKGROUND

(While you're running WordStar, Lotus, dBase, a compiler or whatever)

We wanted electronic mail that could take care of itself while we were busy on the computer doing something else.

We always felt that there was something strange about having to play postman every time a piece of electronic mail was due. It was always a case of loading up a communications package and either waiting for the mail or going out to fetch it.

Now, we've got it! And you can have it, too. With HOMEBASE, Electronic mail can arrive while you're working in another piece of software. Up in the corner of your screen, a signal lets you know that there's incoming mail. You can read it as it comes in, if you want. Or you can ignore it, and your mail will automatically file itself . . . to be read at your leisure.

When you're sending Electronic Mail, it's just as easy. Once you've written and addressed your letter, the rest is done for you, automatically, while you're back working in another piece of software.

## CHECK THE DIFFERENCE IN VALUE!

### WHY ARE YOU GETTING SO MUCH SOFTWARE FOR SUCH A SMALL PRICE?

Amber Systems makes tools for programmers including VSI—The Window Machine. We make mouse drivers, asynchronous drivers and electronic mail packages for a number of companies. Now, we've decided to use these tools, plus some new ones that aren't yet on the market, to produce new concepts in software. Because we make the tools ourselves, our costs, and consequently yours, are the lowest possible . . . with never a compromise in quality.

**YES! Site licenses are available** for companies . . . large and small. If you would like to order a single copy, now, to examine and show around your company, its cost can be deducted, later on, from your site license.

For further information on site licenses call 408-996-1883.

Inquiry 22

<b>HOMEBASE</b>	<b>SIDEKICK</b>	<b>POLY WINDOWS</b>	<b>SPOTLIGHT</b>
Notepad Autodialer Appointment Calendar DOS Services Calculator Rolodex Rolodex Card Printer Tables and Pages Alarm Clock Template Maker Instant Databases Data Transfer Cut and Paste Programmable HotKey Phone Message Pad Time and Expense Diary To-do List Electronic Mail Quickterm Terminal Mailing Label Printer	Notepad Autodialer Calendar Calculator ASCII Table Rolodex	Notepad Keyboard Macros Calendar Calculator Game Alarm File Cards	Notepad Calendar DOS Services Calculator Rolodex File Cards
<b>\$49.95 !</b>	<b>\$49.95</b>	<b>\$49.95</b>	<b>\$149.95</b>

Sidekick is a trademark of Borland International, Inc. Poly Windows is a trademark of Polytron Corp. Spotlight is a trademark of Software Arts.

**ORDER YOUR COPY OF HOMEBASE TODAY!**

**For VISA and MasterCard Orders Call Toll Free : 800-538-8157 Ext. 824**

**In CA 800-672-3470 Ext. 824**

**Call Mon. - Fri. 6 A.M. to 12 P.M., Sat. & Sun. 6 A.M. to 8 P.M. (P.S.T.)**

or fill in this ORDER FORM and enclose a check, money order or your VISA or MasterCard number.

**HOMEBASE** is available for the IBM PC, XT and true compatibles  
 \$49.95 + \$5 for shipping and handling\*

NAME \_\_\_\_\_  
 TITLE \_\_\_\_\_  
 COMPANY NAME \_\_\_\_\_  
 ADDRESS \_\_\_\_\_  
 CITY \_\_\_\_\_ STATE \_\_\_\_\_ ZIP \_\_\_\_\_  
 HOME PHONE ( ) \_\_\_\_\_ WORK PHONE ( ) \_\_\_\_\_  
 CHECK  MONEY ORDER  VISA  MASTERCARD Card # \_\_\_\_\_ Exp. date \_\_\_\_\_

**30-day money-back guarantee!**

SEND TO:

**AMBER**  
 AMBER SYSTEMS, INC.  
 1171 S. Saratoga-Sunnyvale Road  
 San Jose, CA 95129

\*California residents add 6% sales tax. Outside U.S. please add \$15. Checks must be on a U.S. bank and in U.S. dollars. Sorry, no C.O.D. or purchase orders.  
 For dealer and site license information, call 408 996-1883.



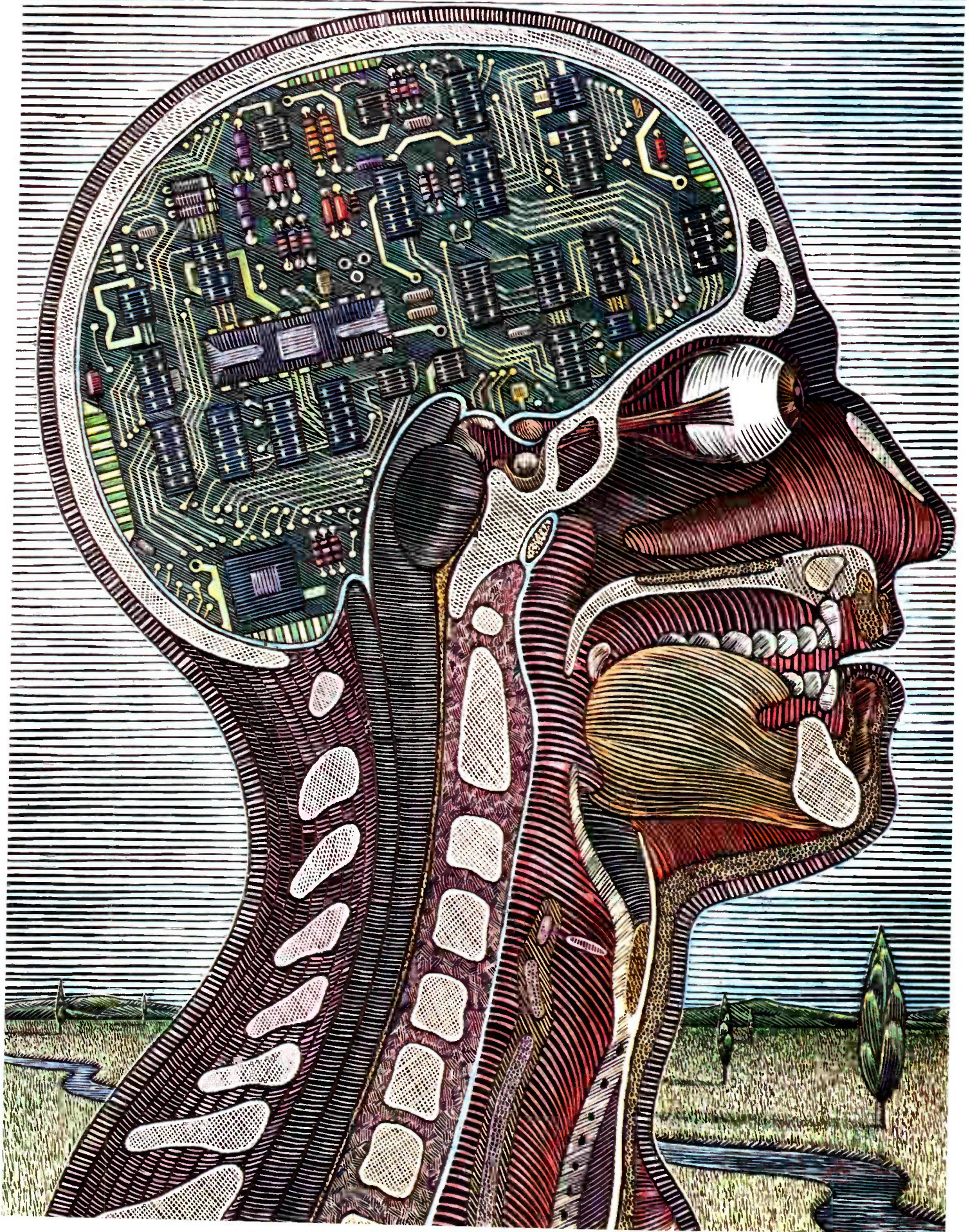



# Artificial Intelligence

---

<b>COMMUNICATION WITH ALIEN INTELLIGENCE</b> <i>by Marvin Minsky</i> . . . . .	<b>126</b>
<b>THE QUEST TO UNDERSTAND THINKING</b> <i>by Roger Schank and Larry Hunter</i> . . . . .	<b>143</b>
<b>THE LISP TUTOR</b> <i>by John R. Anderson and Brian J. Reiser</i> . . . . .	<b>159</b>
<b>PROUST</b> <i>by W. Lewis Johnson and Elliot Soloway</i> . . . . .	<b>179</b>
<b>ARCHITECTURES FOR AI</b> <i>by Michael F. Deering</i> . . . . .	<b>193</b>
<b>THE LISP REVOLUTION</b> <i>by Patrick H. Winston</i> . . . . .	<b>209</b>
<b>THE CHALLENGE OF OPEN SYSTEMS</b> <i>by Carl Hewitt</i> . . . . .	<b>223</b>
<b>VISION</b> <i>by Dana H. Ballard and Christopher M. Brown</i> . . . . .	<b>245</b>
<b>LEARNING IN PARALLEL NETWORKS</b> <i>by Geoffrey E. Hinton</i> . . . . .	<b>265</b>
<b>CONNECTIONS</b> <i>by Jerome A. Feldman</i> . . . . .	<b>277</b>
<b>REVERSE ENGINEERING THE BRAIN</b> <i>by John K. Stevens</i> . . . . .	<b>286</b>
<b>THE TECHNOLOGY OF EXPERT SYSTEMS</b> <i>by Robert H. Michaelsen, Donald Michie, and Albert Boulanger</i> . . . . .	<b>303</b>
<b>INSIDE AN EXPERT SYSTEM</b> <i>by Beverly A. Thompson and William A. Thompson</i> . . . . .	<b>315</b>

---

YOU AWAKE ONE MORNING to find your brain has another lobe functioning. Invisible, this auxiliary lobe answers your questions with information beyond the realm of your own memory, suggests plausible courses of action, and asks questions that help bring out relevant facts. You quickly come to rely on the new lobe so much that you stop wondering how it works. You just use it. This is the dream of artificial intelligence. In this issue of *BYTE*, a group of distinguished authors, including leading researchers, examine the state of this challenging field. While the auxiliary lobe is a distant dream, some of these articles show that AI has won a place on personal computers.

Understanding artificial intelligence requires understanding intelligence itself. Marvin Minsky of MIT explores the concept of intelligence and considers whether we will be able to communicate with extraterrestrial intelligence when we encounter it. Some of the conceptual structures needed to make computers perform operations natural to the human mind are covered by Roger Schank and Larry Hunter of Yale.

Computer science is among the first fields to benefit from AI. John Anderson and Brian Reiser of Carnegie-Mellon describe their interactive LISP program that teaches people to program in LISP, while Yale's Lewis Johnson and Elliot Soloway explain the operations of their LISP program that finds nonsyntactic bugs in Pascal programs.

If we are to have powerful AI on personal computers, we must have efficient hardware and software. Michael Deering of Schlumberger Research surveys some efficient architectures for AI. After noticing the recent flowering of LISP on personal computers, MIT's Patrick Winston provides an introduction to the language. Carl Hewitt, developer of an early logic programming language, questions whether logic programming will be able to develop intelligent systems for complex applications in the real world.

In their article, Dana Ballard and Chris Brown of Rochester University explain how the miracle of vision rests on hierarchical representations of information as well as on parallel processing. Parallelism is explored further by Geoffrey Hinton of Carnegie-Mellon, who presents two theories of how learning could occur in brain-like networks. Jerome Feldman of Rochester elaborates on key issues in massive parallelism in both natural and artificial intelligence. John Stevens of the University of Toronto takes a bold and intriguing look at the possibilities of copying the brain's own circuitry directly. He starts with the device physics of the brain and goes on to discuss silicon-based designs.

The methods for building expert systems discussed by Robert Michaelsen, Donald Michie, and Albert Boulanger include not only those based on rules but also those based on deeper representations of knowledge. Beverly and William Thompson explain a rule-based expert system written in Pascal.

Space limitations prevented the inclusion of Michael Fichtelman's expert system in Logo and Phillip Robinson's description of a custom AI chip developed at Syracuse University. Look for these articles in forthcoming issues.

Many of the technical terms used in the context of AI involve subtle variations on the traditional computer science definitions. Please consult the glossary on page 138 for definitions of several of these terms.

—Phil Lemmons, Editor in Chief







# COMMUNICATION WITH ALIEN INTELLIGENCE

BY MARVIN MINSKY

---

*It may not be as difficult as you think*

WHEN FIRST WE MEET those aliens in outer space, will we and they be able to converse? I believe that, yes, we will—provided they are motivated to cooperate—because we'll both think in similar ways. I propose two kinds of arguments for why those aliens may think like us, in spite of having very different origins. These arguments are based on the idea that all intelligent problem solvers are subject to the same ultimate constraints—limitations on space, time, and materials. For animals to evolve powerful ways to deal with such constraints, they must have ways to represent the situations they face, and they must have processes for manipulating those representations. These two requirements are:

*Economics: Every intelligence must develop symbol systems for representing things, causes, and goals, and for formulating and remembering the procedures it develops for achieving those goals.*

*Sparseness: Every evolving intelligence will eventually encounter certain very special ideas—e.g., about*

*arithmetic, causal reasoning, and economics—because these particular ideas are very much simpler than other ideas with similar uses.*

The economics argument is that the power of a mind depends on how it manages the resources it can use. The concept of *thing* is indispensable for managing the resources of space and the substances that fill it. The concept of *goal* is indispensable for managing how we use the time we have available—both for what we do and what we think about. Aliens will use these notions too, because they are both easy to evolve and because there appear to be no easily evolved alternatives for them.

The sparseness theory tries to make this more precise by showing that almost any evolutionary search will soon find certain schemes that have no easily accessible alternatives, that is, other different ideas that can serve the same purposes. These ideas or processes seem to be peculiarly isolated in the sense that the only things that resemble them are vastly more complicated. I will discuss only

the specific example of arithmetic and conjecture that those other concepts of objects, causes, and goals have this same island-like character.

*Critic: What if those aliens have evolved so far beyond us that their concerns are unintelligible to us and their technologies and conceptions have become entirely different from ours?*

Then communication may be infeasible. My arguments apply only to those stages of mental evolution in

*(continued)*

*Artificial-intelligence pioneer Marvin Minsky is Donner Professor of Science in the Department of Electrical Engineering and Computer Science at Massachusetts Institute of Technology (545 Technology Square, Cambridge, MA 02139). In the late 1950s, Minsky, together with John McCarthy (now at Stanford), created MIT's AI Laboratory, of which Minsky was the director for several years. Minsky has long been interested in SETI (the Search for Extraterrestrial Intelligence) and participated in the important 1971 conference on communication with extraterrestrials, held in Soviet Armenia and organized by Carl Sagan.*



*A distinctive aspect  
of intelligence is  
the ability to solve  
new, different problems.*

which beings are still concerned with surviving, communicating, and expanding their control of the physical world. Beyond that, we may be unable to sympathize with what they come to regard as important. Yet even then we can hope to communicate with the mental mechanisms they use to keep account of space and time; these could remain as sorts of universal currency.

*Critic: How can we be sure that things like plants and stones or storms and streams are not intelligent in other ways?*

If you can't say in what respects their intelligence is similar, it makes no sense to use the same word. They certainly don't seem good at solving the kinds of problems that challenge our intelligence.

*Critic: What's so special about solving problems? Please define intelligence precisely so that we'll know what we are discussing.*

It's not one author's place to tell other people how to use a word that they already understand. Let's just use intelligence to mean what people usually mean: the ability to solve hard problems—like how to build spaceships and long-distance communication systems.

*Critic: Then please define what a hard problem is. For instance, we know that human intelligence was involved in building the pyramids—yet coral-reef animals build things on an even larger scale. Should we therefore be able to communicate with them?*

No. Humans do indeed solve such problems, but it is only an illusion that coral-reef animals do. An important factor is speed. No single bird dis-

covers how to fly: Evolution used a trillion bird-years to find out how—yet man learned to fly in tens of human-years. And while a person might take several years to find a way to build a structure like an oriole's nest or a beaver's dam, no oriole or beaver could ever learn to do such things at all without exploiting the ancient nest-machines their genes construct inside their brains. A distinctive aspect of what we call intelligence is this ability to solve a wide range of new, different kinds of problems. This is why it makes sense to try to communicate with an individual animal that can learn quickly how to solve new hard problems.

What enables us to solve hard problems so quickly? Here are some ingredients that seem to me so essential that I would expect intelligent aliens to use them, too:

*Subgoals—to break hard problems into simpler ones*

*Subobjects—to make descriptions based on parts and relations*

*Cause-symbols—to explain and understand how things change*

*Memories—to accumulate experience about similar problems*

*Economics—to efficiently allocate scarce resources*

*Planning—to organize work before filling in details*

*Self-awareness—to provide for the problem solver's own welfare*

Still, aren't these only a few of the myriads of other possibilities? Why can't our aliens do all such things in completely alien ways? I believe that these problem-solving schemes are not as arbitrary as they seem.

**THE SPARSENESS PRINCIPLE**

Why does it seem so obvious to us that two and two equal four? Such mysteries have long concerned philosophers—why certain concepts seem to come into our minds as though they need no prior experience or evidence. My answer is that this may be due, at least in part, to the following *computational phenomenon*.

*The Sparseness Principle: Whenever two relatively simple processes have*

*products that are similar, those products are likely to be completely identical.*

Because of this, we can expect certain a priori structures to appear, almost always, whenever a computational system evolves by selection from a universe of possible processes. The ideas of number and arithmetic are examples of this, and my conjecture is that this may be why different people can communicate so perfectly about such matters, although their minds may differ in many other ways. This may apply to aliens, too. Let me explain the sparseness principle by recounting two anecdotes. One involves a mathematical experiment, the other a real-life experience.

**A Mathematical Experiment**—I once set out to explore the behaviors of all possible processes—that is, of all possible computers and their programs. There is an easy way to begin that search: you just list all possible finite sets of rules, one by one. This is easy to do using methods that Alan Turing described in 1936; these are what today we call "Turing machines." Naturally, I didn't get very far because the variety of such processes grows exponentially with the number of rules in each set. However, with the help of my student, Daniel Bobrow, I managed to examine the first few thousand of such machines—and we found that among them there were only a few distinct kinds of behaviors. Some of them simply stopped without accomplishing anything. Many of the others just erased their input data and did nothing else. Most of the remainder quickly got trapped in circles, senselessly repeating the same steps over again. There were only a few left that did anything interesting at all—and these were all essentially the same: Each of them performed a counting operation that repeatedly increased by one the length of a string of symbols. In honor of their ability to do what resembles a fragment of simple arithmetic, let's call these *A-machines*. Let's think of this exploration as exposing parts of some infinite

*(continued)*



Golden  
Common  
LISP

# Gold Hill Computers brings the language of Artificial Intelligence to Your Personal Computer.

## Why every Computer Professional should know COMMON LISP.

You know how frustrating it is to deal with programs that are stupid and inflexible like those buried inside automated bank teller machines and airline reservation systems. You also know how frustrating it is to engineer solutions to today's information-processing problems with languages designed mainly for number crunching. *It doesn't have to be this way.*

Programs based on the ideas of Artificial Intelligence and implemented in COMMON LISP can be intelligent, flexible, and human-like. When you use COMMON LISP in combination with artificial intelligence techniques, you will be able to *solve problems you could never solve before*. You will be able to write powerful programs that can accommodate naive computer users who want intelligible answers to questions quickly.

The best way to get started is to buy GOLDEN COMMON LISP™, the first COMMON LISP for personal computers.

## GOLDEN COMMON LISP: The AI Tutor

GOLDEN COMMON LISP makes it easy for you to learn to use COMMON LISP, on your personal computer, by yourself, at your own pace. The San Marco LISP Explorer™, a 1000-frame interactive software slide show developed by Patrick H. Winston and San Marco Associates, takes you through COMMON LISP and exciting *artificial intelligence applications* like expert systems, intelligent data-access systems, and natural language interfaces.

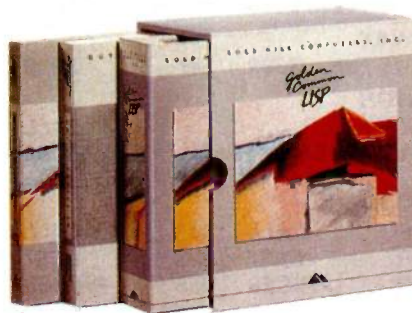

## GOLDEN COMMON LISP: The Complete Lisp Environment

The GOLDEN COMMON LISP package includes:

- the GCLISP interpreter
- the GMACS editor
- the San Marco LISP Explorer
- the On-line Help system
- LISP, 2nd edition by Winston and Horn
- the COMMON LISP Reference Manual by Steele
- the GOLDEN COMMON LISP User's Manual

## GOLDEN COMMON LISP: The Powertool for Personal Computing

GOLDEN COMMON LISP is an extensive subset of COMMON LISP, supporting more than 400 LISP primitives. Advanced features of GOLDEN COMMON LISP include co-routines for multi-tasking, macros for code clarity, streams for I/O, closures for object-centered programming, and multiple-value-returning functions for efficiency.

GOLDEN COMMON LISP requires an IBM, PC XT, PC AT, or 100% IBM PC compatible computer with 512K bytes of memory and PC-DOS 2.0 or higher. More memory is recommended for applications development.

**ORDER GCLISP TODAY** using the coupon below. Or call our Sales Department at:

**617-492-2071**

Gold Hill Computers BI-85  
163 Harvard Street  
Cambridge, MA 02139

Name \_\_\_\_\_  
 Title \_\_\_\_\_  
 Department \_\_\_\_\_  
 Organization \_\_\_\_\_  
 Address \_\_\_\_\_  
 Phone \_\_\_\_\_ Today's Date \_\_\_\_\_

Type of computer \_\_\_\_\_  
 Enclosed is a check to Gold Hill Computers for GCLISP.  
 Please bill my  MasterCard  VISA card.

Card # \_\_\_\_\_ Expiration Date \_\_\_\_\_

Quantity	Description	Unit Price	Total Price
	GOLDEN COMMON LISP	\$495	
Subtotal			
MA residents add 5% Sales Tax			
Total Amount			

We welcome inquiries about volume discounts, dealer discounts, and educational discounts for university-affiliated purchasers.  
 Please send me more information.

**G O L D H I L L C O M P U T E R S**

163 Harvard Street, Cambridge, Massachusetts 02139

Inquiry 167

GOLDEN COMMON LISP and GCLISP are trademarks of Gold Hill Computers. The San Marco LISP Explorer is a trademark of San Marco Associates. LISP is copyrighted by Addison-Wesley Publishing Company, Inc. The COMMON LISP Reference Manual is copyrighted by Digital Equipment Corporation. IBM PC, PC XT, PC AT, and PC-DOS are trademarks of International Business Machines.



# COMPUTER HUT™

COMPARE  
OUR  
SERVICE & PRICE!

## SPECIAL OF THE MONTH

IBM-PC, XT & AT  
CALL FOR  
PRICE

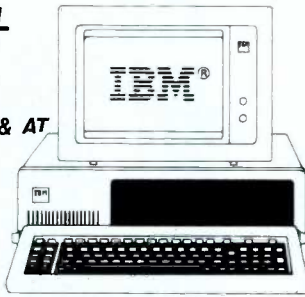

## DISK DRIVES

<b>Tandon</b> TM100-2 DS/DD	\$165
<b>MATSUSHITA</b> JA 551	\$149
<b>TEAC</b> FD-55B Slimline	\$149
<b>SHUGART</b> SA-455 half-high	CALL

## HARD DISKS/TAPE

<b>MAYNARD</b>	
WSI	\$895 WS2 \$1095
EVEREX, SYSGEN, MOUNTAIN	CALL

<b>ME MAYNARD ELECTRONICS</b>	
Floppy Disk Controller	\$129
FDC w/Par. Port or Ser Port	\$179/189
SANDSTAR SERIES	CALL

<b>QUADRAM</b>	
Quadboard 64K exp. to 384K	\$279
Quadcolor I & II	CALL

<b>AST RESEARCH</b>	
SixPak Plus 64K	\$279
MegaPlus II 64K	\$279
I/OPlus II	\$129
<b>STB</b>	CALL

<b>MICROLOG</b>	
Baby Blue II 64K	\$489

## GRAPHICS BOARDS

<b>TECMAR</b>	
Graphics Master	\$489

<b>HERCULES</b>	
Hi Res Mono Graphics	\$329
Color Graphics w/Par Port	\$185

<b>PARADISE</b>	
Modular Graphics	\$299

ANY PRODUCT NOT  
LISTED? CALL

## MODEMS

<b>Hayes</b>	
Smartmodem 1200	\$469
Smartmodem 1200B	\$409
<b>BIZCOMP</b>	
PC Intellimodem	\$359
PC Intellimodem-ST	CALL
<b>NOVATION</b>	
SmartCat	\$359

## PRINTERS

<b>EPSON</b>			
FX-80	CALL	FX-100	CALL
RX-80	CALL	RX-100	CALL
JX-80	CALL	LQ-1500	CALL

<b>brother</b>			
HR-15 Par	\$399	Ser	\$399
HR-25	\$649	HR-35	\$839

<b>DYNAX</b>			
DX-15 Par	\$399	Ser	\$399

<b>C-ITOH</b>			
PROWRITER			CALL
STARWRITER F-10P			\$1095

<b>OKIDATA</b>			
84P	CALL	84S	CALL
92P	BEST	92S	BEST
93P	PRICES	93S	PRICES

<b>NEC</b>			
Spinwriter 2050			\$699
3550	\$1449	8850	\$1995
Pinwriter P2	\$689	P3	\$895

<b>TOSHIBA</b>			
P1351	\$1399	P1340	\$775

<b>DAISYWRITER</b>			
2000 w/48K Buffer			\$849

<b>DATAPRODUCTS</b>			CALL
---------------------	--	--	------

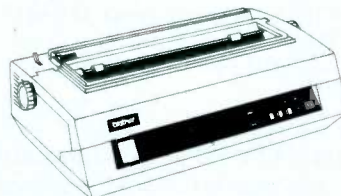

ASK ABOUT OUR  
TRAINING & REPAIR  
SERVICES.

## COMPUTERS

<b>COLUMBIA</b>	
DATA PRODUCTS, INC	
<b>COMPAQ</b>	CALL

## MONITORS

<b>AMDEK</b>			
Video 300G	\$135	300A	\$145
Video 310A			\$179
<b>PGS</b>			
HX12 Hi Res RGB monitor			BEST
MAX-12 Hi Res Mono			PRICES
SR-12 Super Hi Res RGB			



## SOFTWARE

<b>WORDPROCESSING</b>			
MS Word	\$239	with mouse	\$299
Volkswriter Deluxe			\$169
PFS: Write	\$89	PFS: Proof	\$69
WordPerfect	\$269	WordStar	CALL
Multimate	\$269		

<b>DATABASE/INTEGRATED</b>			
dBase III	\$389	Quickcode III	\$179
RBase 4000	\$279	Clout 2.0	\$169
LOTUS 1-2-3 & Symphony			CALL
Framework			CALL

<b>UTILITIES/COMPILERS</b>			
Crosstalk	\$109	Smartcom II	\$109
Sideways	\$49	Norton Utilities	\$59
Sidekick	\$45	Turbo Pascal	\$45
LIFEBOAT Lattice C			\$299
MS Basic	\$259	MS Fortran	\$239

<b>BUSINESS</b>			
MICROSOFT Project	\$159	Chart	\$159
STAR Acct. Partner I & II			CALL
BPI SYSTEMS			CALL
PFS: File	\$89	PFS: Graph	\$89
PFS: Plan	\$89	Multiplan	\$139

<b>OTHER</b>			
Mastertype	\$35	Typing Tutor III	\$39
Math Blaster			\$39
Flight Simulator			\$45
Managing your money			\$135

AND LOTS MORE

## EAST COAST

**COMPUTER HUT**  
OF NEW ENGLAND INC.

101 Elm St. Nashua, NH 03060

**(603) 889-0666**

For Orders Only — (800) 525 5012

## CANADA

**MICROCONTEXT**

AUTHORIZED DEALER

5253 Ave Du Parc  
Montreal Que H2V4P2.

**(514) 279-7291**

## MID-WEST

**COMPUTER HUT INC.**

524 S. Hunter  
Wichita, Kansas 67207

**(316) 681-2111**

For Orders Only — (800) 572 3333

All products usually in stock for immediate shipment and carry full manufacturers' warranty. Price subject to change — this ad prepared two months in advance. You get the lowest price. We honor personal checks — allow 10 days to clear. COD up to \$300 add 2%. Visa, MasterCard add 2%. For shipping & insurance add 2% or \$5.00 min. for small items and \$10 min for monitors, printers, etc. We accept company checks and P.O.'s from Fortune 1000 Companies.

IBM is a trademark of IBM Corp.

Return authorization and order status call information line

Inquiry 83



"universe of possible computational structures." Then this tiny fragment of evidence suggests that such a universe may look something like figure 1.

The Xs represent those useless processes that scarcely do anything at all, while the As represent those little counting machines, which in effect are all identical. Little processes like these, inside our minds, could be seeds of our more mature ideas about arithmetic. My point is that it seems inevitable that somewhere in a growing mind some A-machines must come to be.

Now, possibly, there are some other really different ways to count. So there may appear much later some of what we represent as *B-machines*, which are processes that act in ways that are similar but not identical to the ways A-machines behave. But our experiment hints that even the simplest possible B-machine will be so much more complicated that it is unlikely any brain would discover one before it first found many A-machines.

I think of this little thought experiment as resembling an abstract version of those first experiments in which Stanley Miller and Harold Urey set out to explore with real chemicals the simplest combinations of constituents. They started with a few elements like hydrogen, oxygen, nitrogen, carbon, and phosphorus and found that those chemicals react first to make simple molecules and then go on to form peptides, sugars, nucleotides, and whatnot. Of course, we would have to wait much, much longer before the appearance of tigers, woodpeckers, or Andromedans.

**A Real-Life Episode**—Once, while I was still a child in school, I heard that *minus times minus is plus*. How strange it seemed that negatives could cancel out—as though two wrongs could make a right, or "this statement lies" could be a truth. I wondered if there could be something else, still like arithmetic but having yet another sign. Why not make up some number things, I thought, that go not just two ways, but three? I searched for days,

making up new little multiplication tables. Alas, each system ended either with impossible arithmetic (e.g., with one and two the same), with no signs at all, or with an extra sign. Eventually, I gave up. If I had had the courage to persist, as Gauss did, I might have discovered the arithmetic of complex numbers or, as Pauli did, the arithmetic of spin matrices. But no one ever finds a three-signed imitation of arithmetic because, it seems, it simply doesn't exist.

Try, for example, to make a new number system that's like the ordinary one except that it *skips* some number—say, 4. It just won't work. Everything will go wrong. You'll have to decide what 2 plus 2 is. If you say that this is 5, then 5 will have to be an even number, and so also must 7 and 9. Then, what's 5 plus 5? Is it 8, or 9, or 10? You'll find that to make the new system at all like arithmetic you'll have to change the properties of all the other numbers. Then, when you're done, you'll find that you have changed only those numbers' names and not their properties at all.

Similarly, you could try to make two different numbers be the same—say, 139 and 145. But then, to make subtraction work, you'll have to make 6 the same as 0 and 4 plus 5 equal to 3. Suddenly, you'll find that the sum of two positive numbers is smaller than either of them—and that scarce-

ly resembles arithmetic at all. (In fact, this leads to *modular arithmetic*, which has a certain usefulness in abstract mathematics but is worse than useless for keeping track of real things.) And so it goes.

There is just no way to take a single number out or put another one in. Nor can you change a single product, sum, or prime.

What gives arithmetic this stark and singular rigidity? You cannot make the smallest hole in it or make it stretch or bend the slightest bit. You have to take it as it stands, the whole thing, all or nothing, unchangeable, because it's isolated as an island in that universe of processes. That selfsame A-machine exists, immutably complete, as part of every other process that can generate an endless chain of different things.

I sometimes wonder if it's dangerous to make our children dwell so long on arithmetic since, when seen this way, it leads to such a singularly barren world. True, some children find in it a universe of different things to do. Most children, though, just find it dull—a source of endless rote and pointless pain; it's like the tedium of working clay too cold to mold into any other shape.

From all this, I conclude that any entity who searches through the simplest processes will soon find frag-

(continued)

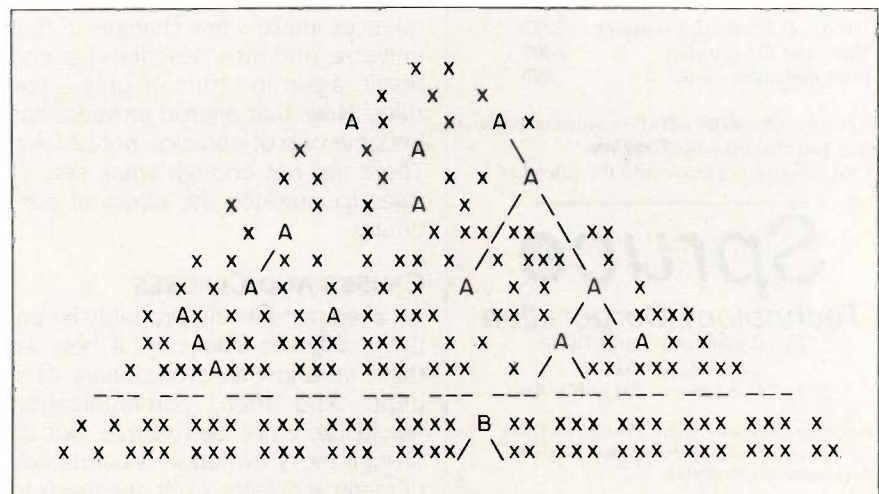

Figure 1: A universe of possible computational structures.



# Pascal and C Programmers

Your programs can  
now compile the

## ***FirstTime™***

*FirstTime* is an intelligent editor that knows the rules of the language being programmed. It checks your statements as you enter them, and if it spots a mistake, it identifies it. *FirstTime* then positions the cursor over the error so you can correct it easily. *FirstTime* will identify all syntax errors, undefined variables, and even statements with mismatched variable types. In fact, any program developed with the *FirstTime* editor will compile on the first try.

### More than a syntax checker!

*FirstTime* has many unique features found in no other editor. These powerful capabilities include a zoom command that allows you to examine the structure of your program, automatic program formatting, and block transforms.

If you wish, you can work even faster by automatically generating program structures with a single key-stroke. This feature is especially useful to those learning a new language, or to those who often switch between different languages.

**Other Features:** Full screen editing, horizontal scrolling, function key menus, help screens, inserts, deletes, appends, searches, and global replacing.

Programmers enjoy using *FirstTime*. It allows them to concentrate on program logic without having to worry about coding details. Debugging is reduced dramatically, and deadlines are more easily met.

<b>FirstTime</b> for PASCAL	\$245
<b>FirstTime</b> for C	\$295
Microsoft PASCAL Compiler	\$245
Microsoft C Compiler	\$395
Demonstration disk	\$25

Get an extra **\$100 off** the compiler when it is purchased with **FirstTime**. (N.J. residents please add 6% sales tax.)

# Spruce

## Technology Corporation

110 Whispering Pines Drive  
Lincroft, N.J. 07738  
(201) 741-8188 or (201) 663-0063

Dealer enquiries welcome. Custom versions for computer manufacturers and language developers are available.

*FirstTime* is a trademark of Spruce Technology Corporation.



## COMMUNICATION

ments that do not merely resemble arithmetic but are arithmetic. It is not a matter of inventiveness or imagination, only a fact about the geography of the universe of computation, a world far more constrained than that of real things.

*Thesis: All processes or formalisms that resemble arithmetic are either identical to it or else unthinkably complicated. This is why we can communicate perfectly about numbers.*

What has this to do with aliens? Only that they too must have evolved by searching through some universe of possible processes, and any evolutionary process must first consider relatively simple systems and thus discover the same isolated islands of efficiency.

Finally, we ought to ask why processes occur that way without some similar ones nearby? It is hard to formulate this precisely, because the meaning of *similar* depends on what you want to use it for. One way to explain it is to point out that a small set of rules can generate a vast world of implications and consequences. But there is no converse because usually a small set of rules can't describe a large and complex thing. This is simply a matter of arithmetic: There just aren't enough small sets of rules to go around! And that explains why we cannot take some set of rules, use it to generate a universe of consequences, make a few changes in that universe, and then describe that end result, again in terms of only a few rules. Now, that altered universe has become one of miracles, not of laws. There are not enough small sets of rules to produce the effect of continuity.

### CAUSES AND CLAUSES

An alien mind would probably be entirely different from ours if how we think were just an evolutionary accident. And then, communication would likely not be feasible. But although every evolution is composed of many accidents, each one tends to first try relatively simple ways at every stage. Since we're the first on earth to

develop complex languages, and since these languages probably employ many relatively simple principles, it is likely that alien species will share many of these. I propose this in a form so strong that it may seem entirely preposterous at first: I believe that many aspects of our language/grammar forms may be almost inescapable.

Why do we say things like "It soon will start to rain?" Why must we always postulate some agent-cause even when there is no actor on the scene? It doesn't matter if we're right or wrong; we'll find a cause or imagine one. I claim we seek some cause for every difference, move, or change. Sometimes our language syntax forces this on us, but I claim it is not merely a matter of verbal form; it stems from deeper causes in the ways we think. My guess is that even before our ancestors began to speak, they first developed special brain machinery for representing objects, differences, and causes, and our language/grammar later reflected these. Specifically, I suspect that many of our thought processes are based on using the following kinds of mental symbol representations:

*Object-symbols representing things, ideas, or processes—In languages, they often correspond to nouns. Our minds tend to describe every situation, real or mental, in terms of separate object-things and the relations between them.*

*Difference-symbols representing differences between, or changes in, objects—In languages, they often correspond to verbs. When any object undergoes a change or two objects are compared, the mind ascribes some differences to them.*

*Cause-symbols—When any difference is conceived, the mind finds a cause for it, a something that is held responsible. And we use a clever mental trick to represent causes in much the same ways that we represent objects.*

*Clause-structures—For describing complicated situations, we have a trick that lets us treat any expression*

(continued)



# ShareIT™

## Multiuser database management for local area networks

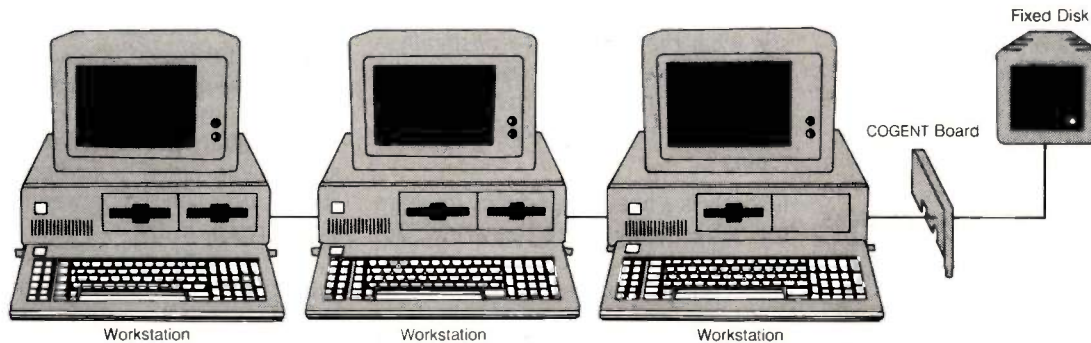

The best-performing multiuser database manager is here today with ShareIT, part of the ITSeries from Martin Marietta. ShareIT offers a unique combination of software and hardware to deliver the performance you need.

### What is the ShareIT software?

KeepIT Plus™, a multiuser version of KeepIT™, the menu-driven relational database manager that forms the centerpiece of the ITSeries of integrated software.

### What is the ShareIT hardware?

The COGENT Database Machine™, a board that provides the interface between KeepIT Plus and the database.

### How are the PCs networked?

Using any of the standard network boards: PCnet, the Novell Gateway adapter card, or IBM's Sytek LAN card. No need for added-cost network operating system software.

### Why does ShareIT work so well?

Because the COGENT Database Machine board provides the hardware performance of a dedicated file server using:

- An 80186 co-processor and disk controller that handle all file access.
- Cache memory for faster buffered access to the database.
- Additional random-access memory for index file processing.
- Firmware for flat file access, B-tree indexing, and record lock.

And KeepIT Plus provides:

- Index file management on the COGENT board without the need to transfer index files across the network.
- Easy-to-use, yet comprehensive, database management.

For more information or the name of the ITSeries dealer nearest you, call 800/222-0592 or 609/799-7500.

For IBM, IBM-compatible, and MS-DOS microcomputers.

The Database Machine is a trademark of COGENT Data Technologies, Inc. PCnet is a trademark of Orchid Technology, Inc. ShareIT, KeepIT, and KeepIT Plus are trademarks of ITSoftware, Inc.

**MARTIN MARIETTA**  
Martin Marietta Data Systems



*or description, however complicated, as though it were a single component of another description. In languages, this corresponds to using embedded phrases and clauses.*

It is that final self-embedding trick of representing prior thoughts as things that gives our minds their awesome power. For this permits us to re-use the same brain machinery over and over again, at each step replacing an entire conceptualization by a compact symbol. That way, we can build up gigantic structures of ideas as easily as our children build great bridges and towers from simple separate blocks. That way, we can build new ideas from old ones—and that is what enables us to think. This applies to our computers as well.

This must be why our languages also have structures that we can re-use: Our thoughts themselves must use the same machinery repeatedly. That's how our thoughts extend themselves to infinite variety. And, unless aliens do that too, they cannot turn their thoughts to the prior products of their thoughts. Without this trick of turning symbols on themselves, you can't have general intelligence, however excellent your repertoire of other skills may be.

*Critic: You might as well argue that the aliens will speak English if you claim they too use nouns and verbs and compound embedded sentences. But what if they don't think in terms of objects and actions at all?*

I don't think it's an accident that we think in terms of thing and cause. Whatever may occur, that form of representation leads us always to wonder who or what is responsible. And so, this evolutionary trick leads us to search to find dependencies that help predict—and hence control—not just the world outside but also what may happen in the mind. Perhaps it's also why we all grow up believing in a *self*: perhaps that "I" in "I just had a good idea" stems from that same machinery. Because if you are compelled to find something to cause the things you do, that something needs to have

a name. You call it "me." I call it "you."

*Critic: But what's so great about dependencies? Why can't some aliens perceive entire scenes as wholes instead of breaking them down into those clumsy parts? Why not, instead, see what there really is, holistically—a steady flow of flux in space in time, instead of arbitrary form-filled mind-made fragments of approximations to reality?*

It surely is a healthy tendency to yearn for better ways to see the world. But worshipping as-yet-undiscovered transcendental schemes can blind us to the power we draw from our usual ways of separating things. Each animal must pay a corresponding price in energy and nourishment for each machine it carries in its brain. Just as clause structure in language lets us focus our entire word machine on each part of a description, our concept of seeing separate things lets us factor situations into parts and then apply our whole mind machine to each part of the problem. Enthusiasts of holism have never understood the hidden cost a mind would have to pay to "see everything at once." We'd never be able to see anything clearly at all.

There have been many speculations on how brains might use something like holograms for memories. But on one side there is no evidence for this; on the other there are few advantages to it. Holograms store no more information than other methods, and computer scientists know other, better ways to add redundancy to memory to make it robust and injury resistant. It is true that holograms can simplify certain kinds of recognitions, for instance, deciding whether a picture contains copies of some specific other picture. But that also makes it much more difficult to make most other kinds of decisions, to say whether a picture contains two sub-pictures that share some specified relationship. In fact, a hologram may be almost the worst possible way to represent relations among the things it represents, because memory and

learning are useful only when they inform us about relations that are at least partially predictable. We do not want our memories to give equal weights to every arbitrary feature of a situation. If a scene contains 50 features, you don't want to equally consider all the quadrillion possible subsets of those features. And so we need some methods for isolating and grouping that can emphasize the most usefully predictable subsets. In short, without the additional constraints on relations between features, which result in the concept of an *object*, we'd simply never see the same thing twice. Then we'd have no way to learn from our experience. No knowledge could accumulate.

## CAUSES AND GOALS

How does having memory help—when no two problems are ever quite the same in all respects? Our past experience would seem to have no relevance unless we had some ways to see which aspects of the world remain the same, while others change. This is why knowledge cannot have much use unless expressed in terms of relations between *predictable* features and the actions that we can take. But given these it then may become possible to predict which actions might cause undesirable features to disappear.

To say that "*y* happened because of *x*" is, in effect, to say that *x* can help you to predict which actions can lead to *y*. It helps to control its environment if an animal can find such *causes*—fragments of predictability that work better than chance. But such predictions aren't useful when too many small effects add up. What are causes anyway? The very concept of a cause involves a certain element of style: A causal explanation must be brief. Unless an explanation is compact, we cannot use it to predict. We would agree that *x* is a cause of *y* if we see that *y* depends much more on *x* than on most other things. But we wouldn't call *x* a cause if it were a discourse that carried on and on, mentioning everything else in the

*(continued)*



# BASF QUALIMETRIC™ FLEXYDISKS.® A GUARANTEED LIFETIME OF OUTSTANDING PERFORMANCE.

*BASF Qualimetric FlexyDisks feature a unique lifetime warranty,\* firm assurance that the vital information you enter on BASF FlexyDisks today will be secure and unchanged tomorrow. Key to this extraordinary warranted performance is the BASF Qualimetric standard... a totally new set of criteria against which all other magnetic media will be judged.*

*You can count on BASF FlexyDisks because the Qualimetric standard reflects a continuing BASF commitment to perfection in magnetic media. One example is the unique two-piece liner in our FlexyDisk jacket. This BASF feature traps damaging debris away from the disk's surface and creates extra space in the head access area for optimum media-head alignment. The result is a guaranteed lifetime of outstanding performance.*

*For information security that bridges the gap between today and tomorrow, look for the distinctive BASF package with the Qualimetric seal. Call 800-343-4600 for the name of your nearest supplier.*

Inquiry 40

\*Contact BASF for warranty details.

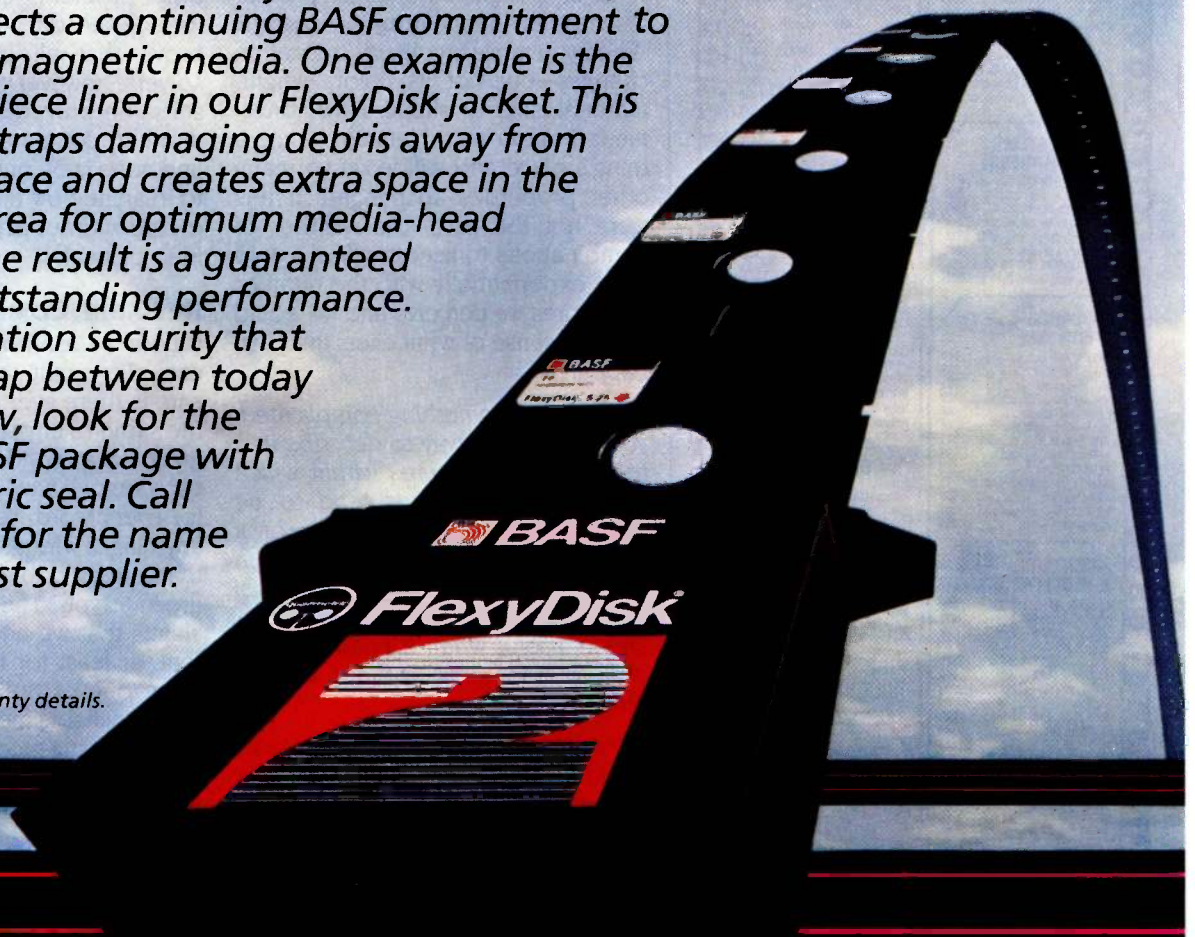

ENTER TOMORROW ON BASF TODAY.

© 1983 BASF Systems Corp., Bedford, MA



**BASF**



# Olden

• COMPUTERS  
• VIDEO  
• PHOTOGRAPHIC  
• ELECTRONICS

FOR INFO CALL (212) 725-1234 **TOLL FREE** FOR ORDERS (800) 221-3160

The Largest Selection - We Stock It All  
50 YEARS Of Reliable Mail Order Service At  
The Lowest Prices

<h3 style="text-align: center; margin: 0;">IBM PC &amp; COMPAT.</h3> <p>IBM PC w/drive, monitor..... Call IBM PC w/256k (2) 360 drives, key board, monitor &amp; monitor adaptor Call IBM PC As Above w/RGB Color Monitor..... Call IBM PC XT w/256k..... Call IBM AT Enhanced..... Call PC JR w/28k..... Call CANON Athena..... Call LEADING EDGE PC w/28k (2) 360 disc drives, monitor &amp; adapter, basic DOS 2.11..... 1499 LEADING EDGE PC w/256k as above but RGB Color..... 1995 LEADING EDGE PC w/256k (1) 360 &amp; (1) 10Mb hard disc, RGB Color Adapter, DOS 2.11 &amp; Basic..... 2795 ZENITH ZF 151 52 w/(2) 369k Disc Drives, 320k RAM, IBM Compatible, w/Free Microsoft Word &amp; Free Microsoft Multiplan &amp; Color Graphics Ready..... 2099</p> <h3 style="text-align: center; margin: 0;">LAP COMPUTERS</h3> <p>COMPAQ PORTABLE w/256k (2) 360 disc drives, DOS, basic..... 2099 COMPAQ PLUS..... Call COMPAQ Desk Pro..... Call HP 110 w/272k RAM, Lotus 123, 80 Col Display, 9.5Lbs..... Call MORROW w/(2) 360k, 13Lbs, Disc Drives, 256k, IBM Compatible Call SANYO 550 2..... 699 SANYO 555 2..... 979</p> <h3 style="text-align: center; margin: 0;">SYSTEMS COMPUTERS</h3> <p>APPLE IIe w/drive..... 849 APPLE IIc..... 899 APPLE Macintosh..... 1699 DEC RAINBOW 100 w/256k (2) disc drives, monitor, keyboard, CPM, select word processor..... 1995 DEC RAINBOW 350 As 100 Except, w/10mb Hard Disc &amp; (1) Floppy 2995</p> <h3 style="text-align: center; margin: 0;">BOARDS FOR IBM</h3> <p>AMOEK MIA..... 389 AST 6 Pak Plus..... 219 AST mega Plus..... 269 AST I/O Plus..... 139 Game port adapter..... 44 KOLA game controller..... 44 STB GRAPX Plus II..... 349 PERSYST mono board..... 174 PERSYST color..... 169 HERCULES graphic card for TTL mono monitor..... 324 HERCULES color card..... 199 QUABOARD w/4k..... 269</p> <h3 style="text-align: center; margin: 0;">PRINTERS &amp; PLOTTERS</h3> <p>OKIDATA 82..... 259 92..... 355 84..... 679 ..... 575 2410..... Call SILVER REED: 400..... 269 500..... 329 550..... 449 770..... 769 DAISY WRITER 2000..... 799 EPSON: RX 80..... 234 LQ 1500..... 1069 OLYMPIA RD..... 349 NEC 3550..... 1449 JUKI 6100 399 6300..... 799 GEMINI STAR 10X..... 239 15X..... 369 HP Laser Printer..... 2795 HP Plotter..... Call Sweet Pea Plotter..... Call</p>	<h3 style="text-align: center; margin: 0;">SOFTWARE 1/IBM</h3> <p>IBM Topview..... 129 Framework or dBase III..... 399 Lotus 123..... 299 Symphony..... 419 Flight Simulator..... 39 Word Star..... 189 WordStar Pro..... 269 Turbo Star..... 289 Multimate..... 249 Word w/Mouse..... 289 Turbo Pascal..... 39 Sidekick..... 39 PC Paintbrush w/Mouse..... 149 NORTON utilities..... 49 Copywrite..... 48 Enable..... 299 Sideways..... 59 Sargon III..... 39 Zork..... 29 R Base 4000..... 254.95 Managing Your Money..... 119 Typing Tutor III..... 34 Master Type..... 34</p> <h3 style="text-align: center; margin: 0;">MONITORS</h3> <p>AMOEK 310A..... 159 GORILLA Green..... 89 LEADING EDGE RGB Color..... 399 PRINCETON GRAPHICS HX 12..... 459 Max 12..... 149 SANYO CRT 30..... 99 CRT 36..... 129 CRT 70..... 549 TAXAN 290 RGB..... 219 TAXAN 410 IBM RGB..... 549 TAXAN 420 Hi Res RGB IBM 419 TTL Green..... 139 TTL Amber 149 XTRON 1000 Lines Hi Res Amber IBM TTL..... 149 ZENITH 122..... 89 123..... 98 124 IBM Compatible..... 139 133 RGB..... 900 135 RGB..... Call</p> <h3 style="text-align: center; margin: 0;">MODEMS</h3> <p>HAYES 1200..... 445 1200B w/Smartcom II..... 409 SMARTCOM II..... 99 2400..... Call NOVATION SMARTCAT Internal..... 369 Extn..... 375 US ROBOTICS Password 1200 349 ACCESSORIES Disc Bank holds 50..... 14 HEAD disc drive cleaner..... 13 VERBATIM drive analyzer..... 29 SURGE PROTECTORS Network cube w/RF filter..... 29 Network 4 outlet w/RF filter..... 59 C-mini outlet w/RF filter..... 59</p> <h3 style="text-align: center; margin: 0;">DISKETTES</h3> <table border="1" style="width: 100%; border-collapse: collapse; font-size: 0.7em;"> <tr> <td>SS/DD</td> <td>DS/DD</td> </tr> <tr> <td>Verbatim Data Life (100)1</td> <td>24</td> </tr> <tr> <td>FIL (10)</td> <td>29</td> </tr> <tr> <td>MAXELL (10)</td> <td>18</td> </tr> <tr> <td>BA5F (10)</td> <td>17</td> </tr> <tr> <td>IBM (10)</td> <td>22</td> </tr> <tr> <td>FAMOUS MAKE</td> <td>13</td> </tr> <tr> <td>SPECIALI TDK</td> <td>19</td> </tr> </table> <p>Quantities of 100 ea 1.35 ea 1.55</p> <h3 style="text-align: center; margin: 0;">TYPEWRITERS</h3> <p>CANON Typestar 5..... 156 CANON Typestar 6..... 256 BROTHER CE 58..... 458 OLYMPIA Compact II..... 399 SMITH CORONA 350M..... 318*</p> <p><small>*After Manufacturer's Rebate</small></p> <h3 style="text-align: center; margin: 0;">CANON COPIERS</h3> <p>PC 10..... 479 PC 20..... 689 PC 25..... 989 4 Black Cartridges..... 199 Color Cartridge..... 64 PC Copier Stand..... 99</p>	SS/DD	DS/DD	Verbatim Data Life (100)1	24	FIL (10)	29	MAXELL (10)	18	BA5F (10)	17	IBM (10)	22	FAMOUS MAKE	13	SPECIALI TDK	19
SS/DD	DS/DD																
Verbatim Data Life (100)1	24																
FIL (10)	29																
MAXELL (10)	18																
BA5F (10)	17																
IBM (10)	22																
FAMOUS MAKE	13																
SPECIALI TDK	19																

<h3 style="text-align: center; margin: 0;">IBM PC</h3> <p>W/4k (1) 360 Disc Drive &amp; Keyboard..... 1499 IBM PC w/256k (2) 360 Disc Drives, Graphics Monitor, Card, Mon, Keyboard &amp; Software Kit 1995 IBM PC AT..... Call</p> <h3 style="text-align: center; margin: 0;">LEADING EDGE PC</h3> <p>W/28k, Leading Edge Monitor, Keyboard, Monitor &amp; Printer Adapter..... 1499</p> <h3 style="text-align: center; margin: 0;">ZENITH ZF 151-52</h3> <p>W/2) 360k Disc Drives, 320k RAM, Microsoft Word, Multiplan, Keyboard, &amp; 90 Day On Sight Service..... 2099</p>	<h3 style="text-align: center; margin: 0;">SANYO 550-2</h3> <p>Now Runs Lotus 123! IBM PC Compatible. 360k Disc Drive, 128k RAM, Word Star Calc, Star &amp; Easy Writer SERIAL CARD..... 699 ..... 189</p> <h3 style="text-align: center; margin: 0;">OLYMPIA RO</h3> <p>Letter Quality, 14 Cps w/Parallel &amp; Serial Ports w/Built In Tractor Feed ONLY!..... 349.95</p> <h3 style="text-align: center; margin: 0;">COMPAQ</h3> <p>Portable W/2) 360k Disc Drives, DOS &amp; Basic Keyboard..... 2199 COMPAQ Plus w/Hard Disc..... In Stock</p>
---	--

1265 Broadway at 32nd St., New York, 10001

CORPORATE ACCOUNTS WELCOME  
TELEX NUMBER 47882 SPWPA  
VISA, MasterCard, Discover, American Express, and New York State Thruway Authority are accepted.  
Some Prices Mail Order Only.  
We Reserve the Right to Limit Quantities.  
Prices Effective April 1985-May 1985

## COMMUNICATION

whole world and never coming to any point. This applies to objects too.

*There can't be any objects, things, or causes in worlds where everything that happens depends, more or less equally, on everything else that happens.*

It makes no sense to talk about a *thing* in such a world, because our very notion of a thing assumes some constellation of properties that stays the same or changes ways we can predict, when other things around it change. When you move an object, its location changes—but not its color, weight, material, size, or shape. How convenient that our world lets us change a thing's place and still leave so many other properties unchanged. If this were not the case, the number of combinations to keep track of would grow exponentially with the number of features we perceive and we would have no sense of what *causes* things to happen.

*To deal with something complicated, you must find a way to describe it in terms of substructures within which the effects of actions tend to be localized. To know the cause of a phenomenon is to know, at least in principle, what can change or control it without changing everything else. This is useful when it enables us to change one thing without making other things worse.*

For a mind to discover causes in its world, it must have sensors that detect changes that are predictably related to the actions it can take. Fortunately, evolution tends automatically to select just such matched sets of sensors and effectors, because in virtually any environment an animal's survival is enhanced if its actions are based on good predictions. So we can expect evolutionary processes to accumulate mechanisms that reflect the causal laws that operate in their environments. And it would seem that the most powerful methods are those that let you make predictions about the effects of contemplated action for plans.

Problems seem hard when their solutions aren't obvious. The most general way we know to solve problems is to set up systems that have some way to make "progress toward a goal." In the late 1950s, A. Newell and H. A. Simon worked out a theory of what they called the "General Problem Solver." This is a theory of how to reach a goal by *making progress*—finding actions that can replace each other problems, each of which has a lower-level difficulty. No one can prove that all intelligent problem solvers, however alien, must use this selfsame principle. But until we find another, comparably general idea—and none is on our horizon—it is hard to imagine how an intelligence could evolve without exploiting some such idea of goal.

### RELIABLE COMMUNICATION

Before we ask how aliens communicate, we ought to ask how humans can. Is there ever a word that means the same to any two of us? Everyone must have wondered once, "Could two persons have different meanings for every word, yet never sense that anything is wrong?" What if each thing that's green or blue to me is blue and green to you? The sparseness theory claims that we need have no fear of that, at least for technical concepts, since one of the two outwardly indistinguishable meanings would probably be vastly more complicated than the other and would never have been conceived in the first place. Sparseness means we can trust one another.

We know very little of where that idea might lead because we know so little about how sparseness isolates any particular concept. But the general idea does seem to support the mathematical and physical intuitions proposed by Hans Freudenthal in *LINCOS*, his book on alien communication, perhaps even in regard to the miniature models he suggests for discussing social and administrative subjects. There is one problem though: Introspection is a poor guide for guessing which of our common-

(continued)



# The fastest micro in the world



No micro in its right mind would want a showdown with Pinnacle.

Its awesome fire power is provided by the superb Motorola 68000 charging along at 12MHZ with no wait states (giving about 3MIPS).

And Pinnacle's ammo belt is just bristling with high powered options to give rapid fire to all seven users.

P-System, Unix,<sup>™</sup> CP/M-68K,<sup>™</sup> Mosys, BOS, Mirage, Tripos all obey instantly – along with their armies of applications.

Up to 8 Megabytes of directly addressable RAM and 110 Megabytes of Winchester storage dance when Pinnacle barks its sharp orders.

And that's just for starters. There's also the Pinnacle IX with TWO 68000's, DMA, and Memory Management hardware. Ideal for disk intensive operating systems like Unix<sup>™</sup> and Pick.

And a Pinnacle LX expansion chassis allowing nine 68000 processors to network 56 users.

A micro's gotta do what a micro's gotta do.

And starting at under \$4000 Pinnacle's just the fastest there is.

**PINNACLE**  
The accessible peak of performance

US DISTRIBUTORS **Pinnacle Systems Inc.** 10410 Markinson Road, Dallas, Texas 75238. Tel. (214) 340-4941. Telex 88-8442

ELECTRONIC MANUFACTURING/SERVICE **Lamtech Electronics Corporation**, 620 Easy Street, Garland, Texas. Tel. (214) 272-3504

INTERNATIONAL SYSTEMS GROUP **ISG Pinnacle**, Dallas, Texas. Tel. (214) 340-4941. (Distributor enquiries invited).

VERTICAL MARKET SYSTEMS **VMS Pinnacle**, Dallas, Texas. Tel. (214) 340-4941.

EUROPEAN DISTRIBUTORS **TDI Pinnacle Ltd**, 29 Alma Vale Road, Bristol BS8 2HL, England. Tel. (0272) 742796. Telex 444653.

UNIX is a Registered Trade Mark of Bell Labs. CP/M-68K is a Registered Trade Mark of Digital Research.

Inquiry 302



sense concepts are really simple, because many things we find easy to do use brain machines whose complexity we cannot sense. For example, we find it easy to stand on two feet, but some aliens might find that quite astonishing.

What other ideas are likely to be universal in the sense of being islands in that sea of possible ideas? Surely the mathematical notions of utility, linear approximation, probability, and the simplest program-like processes are. These could serve to communicate much about trade and commerce, basic facts of biology, and even many principles of mental life—e.g., about objects, goals, and memories. At some point, though, sparseness must fail, because things that are more complicated will have all kinds of variations and alternatives, and

communication will encounter obstacles of every sort.

**THEREFORE**

There is little more that I can say today with any scientific certitude. Tomorrow there could be more, perhaps because of soon-to-come gains in computational power that could let us explore a little further into the mysterious ocean of all possible simple machines. There we might find a few more ideas isolated enough to share with other minds. Such explorations also might tell us more about the origin of life itself by showing us the simplest schemes that could support the simplest forms of evolutionary search. ■

**BIBLIOGRAPHY**

Ernst, G., and Allen Newell. *GPS: A Case*

*Study in Generality and Problem Solving*. New York: Academic Press, 1969.

Freudenthal, Hans. *LINCOS: Design of a Language for Cosmic Intercourse*. Amsterdam: North-Holland, 1960.

Lenat, Douglas. "The Nature of Heuristics," *Artificial Intelligence*, vol. 19, 1982.

Turing, Alan. "On Computable Numbers, With an Application to the Entscheidungsproblem," *Proceedings of the London Mathematical Society*, vol. 2, 1937; reprinted in Martin Davis (ed.), *The Undecidable*. New York: Raven Press, 1965.

**ACKNOWLEDGMENT**

This article is an adapted version of a paper by Marvin Minsky in *Extraterrestrials: Science and Alien Intelligence*, edited by Edward Regis Jr. and published by Cambridge University Press. Copyright March 13, 1984, revised December 10, 1984. The book will be available in the summer of 1985. Reprinted with permission of the editor and Cambridge University Press.

## A GLOSSARY OF ARTIFICIAL-INTELLIGENCE TERMS

**AND, OR, AND STREAM PARALLELISM:** different techniques for implementing parallel operations, based on *and*, *or*, and pipelined execution hierarchies.

**BAGS:** formal mathematical objects that differ from sets in that they allow duplicate items.

**BLACKBOARD:** used in systems composed of independent modules as a means of communication. The blackboard is a common area of memory containing system-state data that all modules can access.

**FRAME:** a knowledge structure (or database) used to describe the attributes that an object possesses, arranged in a "slot and filler" format. Each slot and its contents carry information about a particular aspect of the object.

**GRAIN SIZE:** when used in conjunction with parallel processing, grain size refers to the complexity of the

code chunks allocated to each processor. For example, if processor A is assigned to perform an addition operation while processor B is assigned to perform a sort operation, the grain size of the code assigned to processor A is smaller than that assigned to processor B.

**HEURISTIC:** a technique that improves the efficiency of a problem-solving process, even though its use cannot be strictly justified. In AI, heuristics are typically used to reduce the time required to solve extremely complex search problems.

**KNOWLEDGE ENGINEER:** an AI programmer who constructs expert systems.

**PREDICATES AND DEMONS:** a predicate is a type of function that tests for some condition involving its arguments. A demon is a procedure that activates automatically in response to recognizing a predefined state.

**SCRIPT:** a frame-like knowledge structure used to represent related sequences of events. The slots in a script contain information concerning an event (where the event occurs, people involved, objects manipulated, etc.), and the events are linked in a causal chain.

**SEMANTIC NET:** a graph of nodes and connecting links; the nodes represent objects, and the links represent relationships. A family tree is a good example of a semantic net.

**TAGGED MEMORY ARCHITECTURE:** in AI applications, tagged memory architectures use part of each memory word to convey information about the data stored in the remaining bits of that word, including the data type and format.

**UNIFICATION:** a pattern-matching method; the result of a unification is the assignment of values to the variables of two patterns so that both patterns become identical.



ACCOUNTANTS TO  
ZOO KEEPERS NEED  
DATABASE APPLICATIONS.

HOW CAN I SPEAK  
THEIR LANGUAGE?



## HERE'S HOW: dBASE III™ SOFTWARE

Whether you're keeping track of accruals or zebras, dBASE III™ will easily create specialized applications which speak your customers' language.

You can quickly write applications for your customers because dBASE III contains a high-level language of plain-English commands that's powerful and easy to use. And, because we understand that your customers' needs often change, we made it easy to modify the structure of your database.

Let's say you've set up a database application for a zoo keeper. After using the application for six months, he discovers that he needs to specify the sex of all his animals, an item he forgot to ask for when you created the applica-

tion. You've got 1,397 records entered, but you have to change the structure of the database.

These commands:

**USE ANIMALS**

Selects the database.

**MODIFY STRUCTURE**

Move the cursor to the place where you want to insert the new field.

**Ctrl N** Adds the new field.

The new field will be inserted above the cursor position.

**SEX ← ← 1 ←**

Specifies that the new field is titled "SEX", has the default

value of a character field, and is one column wide.

**Ctrl W** ends your input.

**←** confirms that you're satisfied with what you've done.

Now, your customer is ready to identify his zebras as boys or girls using the program you created for him.

dBASE III makes your programming effort quick and productive because it's an English-language exercise whether your customer is keeping track of cash flow or feeding schedules.

For a dealer near you call (800) 437-4329, ext. 232.

In Colorado (303) 799-4900, ext. 232.



dBASE III and Ashton-Tate are trademarks of Ashton-Tate. ©Ashton-Tate 1985. All rights reserved.

Software from

# ASHTON-TATE™

We'll put you in control.

ronment of the modern office.

It's also free, when you buy a specially marked package of 10 double or

worry about now is when this limited special offer sells out.



Offer available from participating distributors, personal computer dealers and office supply dealers.

Which, if you don't



# Buy 10 flo stop worrying

## Introducing Expert Ease.™ The First Practical Expert Systems Generator For Your IBM PC.

Are you ready to join the Artificial Intelligence revolution?

*Expert system — Type of artificial intelligence program that allows the computer to be taught, using English sentences, to solve a problem.*

You're an Expert. And you're someone who's thought about writing your own expert systems program for quite awhile. The only thing holding you back is that you haven't had the big bucks to buy a mainframe. Now, with Expert Ease™ you can easily create your own expert system on your own IBM PC.

*"Expert Ease is a fascinating new software package that, for the first time, allows experts in any field to create problem-solving expert systems on a microcomputer. . . One of the most interesting, thought provoking programs to come along in quite some time."*

PC Magazine

### Make Your Knowledge Work For You.

Expert Ease is the first practical AI system generator that's just waiting to become as smart and as savvy as you are. It learns as you learn. Simply

*"In a demonstration test, Expert Ease proved to be extremely simple to follow. . . The potential applications are significant."*

The Artificial  
Intelligence Report

### Expert Ease Can Approve Loans Or Load Airplanes.

The applications and uses for Expert Ease are virtually unlimited. You can do something as straightforward as loan approvals or something as complex as recommending the most efficient way to balance the cargo on an airplane. Expert Ease can trouble shoot car problems or diagnose medical problems. You can update, modify, improve, refine or enhance your expert system at any time. In short, anything you can do, it can do as well.

*"Expert Ease can codify any discipline, decision process, or set of rules, policies or procedures. . . Using Expert Ease is simple. . . The approach is like one of a mentor instructing an apprentice."*

Electronics

### Join The Next Generation Of Expert Programmers

written to improve quality control and productivity. Tutorial programs will be developed as learning aids. And experts from all walks of life will be sharing their thoughts in ways that have yet to be conceived.

Human Edge Software Corporation will remarket selected Expert Ease applications. When you develop your million dollar system, contact us first.

If you have an expertise you need Expert Ease. Order now and save \$100!

*"The most intriguing product I saw during the past year was Expert Ease, . . . this early glimpse into what may be next year's hottest software category left me hungry for more. Once you've worked with software that reflects your own thinking, it's hard to be satisfied with anything less."*

Mike Edelhart, Executive Editor  
PC Magazine

### SAVE \$100.

Pay only \$595.  
If your dealer doesn't have Expert Ease yet, order direct point. Order by Master Card or VISA, or call 1-800-624-5227 (in California 1-800-824-7325)

Name \_\_\_\_\_

Address \_\_\_\_\_

City \_\_\_\_\_

State \_\_\_\_\_



# THE QUEST TO UNDERSTAND THINKING

BY ROGER SCHANK AND LARRY HUNTER

*It begins not with complex issues  
but with the most trivial of processes*

ARTIFICIAL INTELLIGENCE, or AI, takes as its subject matter some of the most daunting questions of our existence. What is the nature of mind? What are we doing when we are thinking, feeling, seeing, or understanding? Is it possible to comprehend how our minds really work? These questions have been asked for thousands of years, but we've made little tangible progress at answering them.

AI offers a new tool for those pursuing the quest: the computer. As anyone who has used one can attest, computers often create more problems than they solve. But for probing the issues of mind and thought, that is just what we need.

The fundamental use of computers in helping us understand cognition is to provide a testbed for our ideas about what the mind does. Theories of mind often take the form of process descriptions. For example, a theory of question answering might claim that people first translate a question into an internal representation, use that representation as an index into memory, translate the recalled memory into an appropriate

form for an answer, and then generate the words to communicate it. (This example is offered not as a real theory of question answering but as an example of what a process theory of mind might look like.)

Process theories seem to be a good way of describing what might go on inside the brain. One problem with them, however, is that all too often what looks like a good description really isn't specific enough to make the theory clear. "Use the representation as an index into memory" isn't a good explanation of the processes behind remembering a fact. How are facts recalled? How is the memory organized? What happens when memory gets very large? What if a fact isn't directly encoded in memory but can be inferred from something that is? A researcher trying to write a program that embodies the above simplistic theory would run into all of these problems and more. That's why we need to write programs. Programming forces us to be explicit, and being explicit forces us to confront the problems with our theories.

Not long ago, AI researchers like

ourselves focused on what they considered to be manifestations of highly intelligent behavior: playing chess, proving mathematical theorems, solving complex logical puzzles, and the like. Many AI researchers devoted a lot of energy to these projects and found powerful computational techniques for accomplishing such "intelligent" tasks. But we discovered that the techniques we developed are not the same ones that people actually use to perform these tasks, and we have instead begun to concentrate on tasks that almost any adult finds trivial: using language, showing common sense, learning from past experiences.

## LANGUAGE

We began studying these "trivial" tasks by trying to write programs that

*(continued)*

Roger Schank is chairman of the computer science department at Yale University. Larry Hunter is a graduate student in computer science at Yale. Both authors can be reached at the Yale University Artificial Intelligence Laboratory, 10 Hillhouse Ave., New Haven, CT 06520.



*People understand  
a great deal more  
than the lexical content  
of an utterance.*

could use English (or other natural languages) in a useful way. We wanted such programs to be able to understand the written word well enough to summarize it, translate it into another language, or answer questions about it. We were immediately confronted with the fact that people understand a great deal more than just the immediate lexical content of an utterance. For example, most people would agree that the sentence "John bought a new car" contains a reference to money, even though the word "money" does not appear in the sentence. Any program that understands that sentence would have to be able to answer "Yes" to the question "Did John spend money?"

How could a program know that? One approach might be to associate "money" with the word "bought," claiming that "buy" means "trade money for." This method uses the meanings of the various words in the sentence to build up a representation of the meaning of the whole sentence. That is more or less the right approach, but it has some problems. For one, words are ambiguous, and the inferences we make about their meanings can easily be wrong. "Buy," for example, doesn't always mean money changes hands, as in: "John bought Mary's argument." Ambiguity is so widespread that any program dealing with natural language must have powerful methods for handling it.

Another problem is that often underlying meanings do not come from the definitions of any particular word. Consider the following story: "John went to a restaurant. He ordered a sandwich. The waiter brought it quickly, so he left a large tip." The meaning of this story obviously includes the fact that John ate

the sandwich and paid for it. However, those actions are not implicit in any particular word in the story. How might a computer program infer them? It would have to know about what goes on in restaurants. A person could also conclude that John probably looked at a menu, that he sat at a table, that a cook made the sandwich, and so on. The program needs to be able to fill in the unmentioned gaps in a text with information about the events being described.

There is a solution to both problems: The program must be constantly generating expectations about what will happen next. Ambiguity is rarely noticed by human speakers because the context makes clear which meaning is correct. For a program to be able to resolve ambiguity, it must build up a "context" as well. In other words, the program must have some idea of what will happen next, based on what has happened previously and what it already knows about these kinds of situations. Expectations are very helpful in resolving ambiguity; the expected sense of an ambiguous word is the one that should be assumed. The expectations set up by "The bartender poured scotch on . . ." makes it easy to use the proper sense of "the rocks."

Expectations also help fill in the gaps in a story. They commonly come in bunches or *packages*. When we hear about a restaurant, we expect to hear about a variety of objects, events, and people. There should be a menu, the patron should look at the menu, pick something, tell the order to a waiter or waitress, wait for a while, be served, eat the food, have the table cleared, get a check, pay the check, leave a tip, and depart. As is obvious from this example, expectation packages can be temporally ordered, which makes it possible to infer that "John ate his sandwich" in the earlier example. When an expectation is satisfied, the program can infer that the expectations temporally prior to it are probably also satisfied. People know about common sequences of actions in the world and use that knowledge to generate expectations. There is no way to

understand language without knowing something about the subject matter under discussion.

To build programs that test these ideas, we had to figure out what kinds of expectations exist and specifically how they are used. First, we looked to human behavior to guide us. People constantly generate expectations at many different levels of specificity. We have expectations about what syllable sounds are likely to be heard next that help us resolve ambiguous sounds into words. We have lexical expectations about what words or classes of words will come next. We have expectations of events that are likely to occur. We also have a variety of expectations about other things, like the kinds of goals that various people may have, plans and counterplans involved in pursuing those goals, and emotional reactions to various events.

Then we thought about how a program might handle this. In some sense, every natural-language parser uses expectations. The difference between a traditional, strictly syntactic parser and a more conceptual parser is the source of its expectations. A syntactic parser uses only knowledge about grammar. A conceptual parser uses information from many sources, grammatical and otherwise. While a traditional parser sees syntactic analysis as a preliminary process for other analyses, a conceptual parser sees syntax as only one of many sources of information used simultaneously to understand text.

Many of the low-level expectations of our parsers come from the vocabulary used to represent meaning. Some of our programs have used conceptual dependency (CD) to represent meanings (see reference 1). The basic CD form has slots for an action, an actor, an object, and a directional component (from or to). Each CD action has associated semantic constraints on the kinds of entities that can fill its slots. For example, the CD action *ingest* requires that its object be edible and its actor be alive. When any word that refers to "ingest" appears in a

(continued)



# TATUNG

The giant is awake.



TVT-7220  
(VT-220 emulation)



CM-1370  
13" RGBI High Resolution

Since 1918 we've been quietly designing, manufacturing, and distributing a broad range of products for industry, business, and consumers all over the world. And so we've quietly grown to be a multinational company with almost a billion in sales from the world's toughest markets. Markets that demand quality, performance, and reliability. Which is why Tatung terminals and monitors have become the choice of important systems designers.

Tatung *monitors* are compatible with virtually all popular computer systems. Each model offers superior resolution and CRT color imagery, along with controls for precise picture "tuning". Tatung *terminals* offer operational flexibility, compatibility with all popular systems, and day-in-day-out reliability. But, no matter which model you choose, no other terminal or monitor offers as much...for so little.



**TATUNG**

Inquiry 379

For complete information  
call toll free: 1-800-421-2929.  
In California, call (213) 979-7055.  
TATUNG COMPANY OF AMERICA, INC.  
2850 El Presidio, Long Beach, CA 90810.

Tatung Monitors are available at:  
WESTERN MICRO SYSTEMS  
A Quality Distributor  
Serving the 13 Western States  
Western States 1-800-544-0020  
In California 1-800-338-1600



What every Apple owner  
should know about

# WORD JUGGLER.™

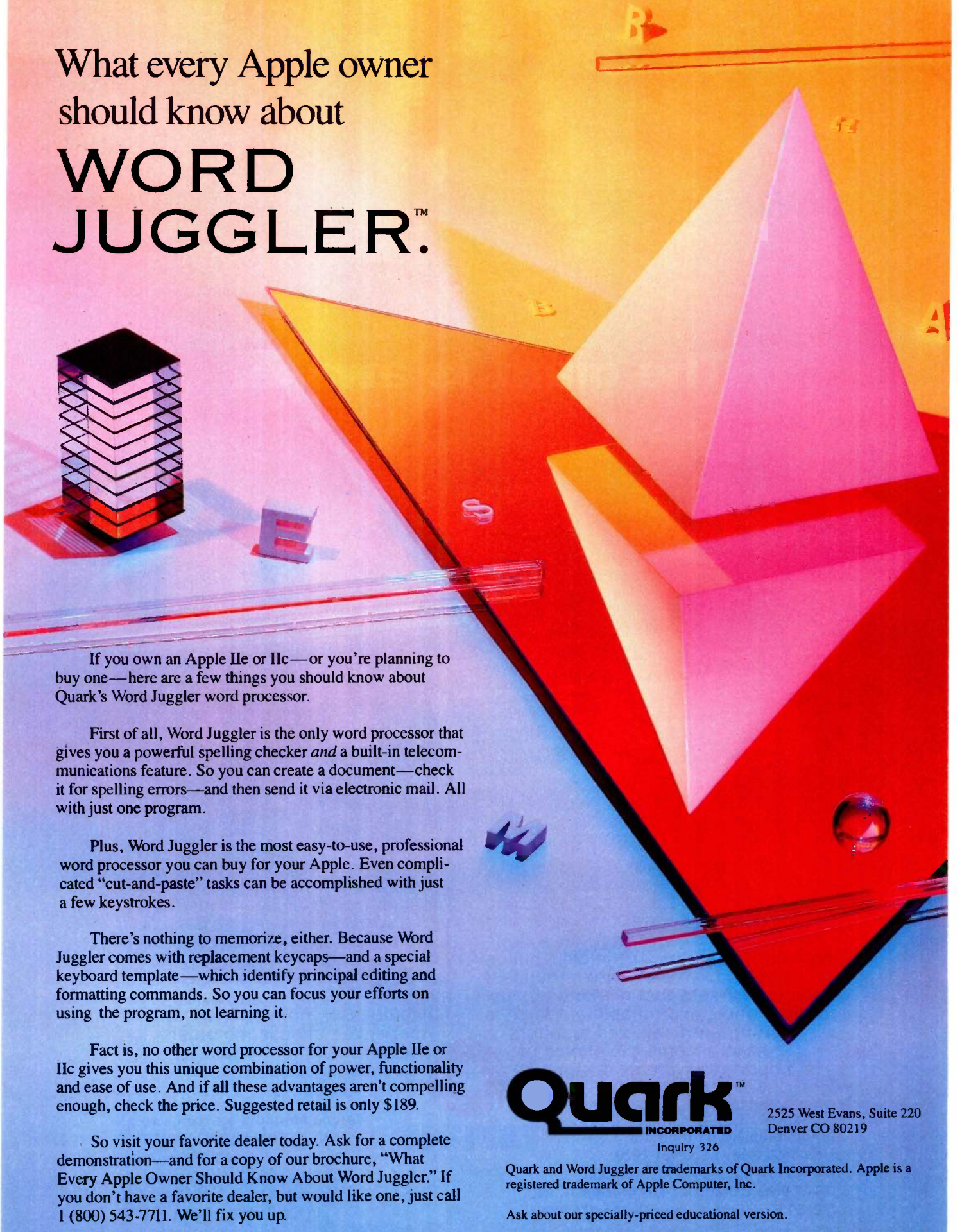

If you own an Apple IIe or IIc—or you're planning to buy one—here are a few things you should know about Quark's Word Juggler word processor.

First of all, Word Juggler is the only word processor that gives you a powerful spelling checker *and* a built-in telecommunications feature. So you can create a document—check it for spelling errors—and then send it via electronic mail. All with just one program.

Plus, Word Juggler is the most easy-to-use, professional word processor you can buy for your Apple. Even complicated “cut-and-paste” tasks can be accomplished with just a few keystrokes.

There's nothing to memorize, either. Because Word Juggler comes with replacement keycaps—and a special keyboard template—which identify principal editing and formatting commands. So you can focus your efforts on using the program, not learning it.

Fact is, no other word processor for your Apple IIe or IIc gives you this unique combination of power, functionality and ease of use. And if all these advantages aren't compelling enough, check the price. Suggested retail is only \$189.

So visit your favorite dealer today. Ask for a complete demonstration—and for a copy of our brochure, “What Every Apple Owner Should Know About Word Juggler.” If you don't have a favorite dealer, but would like one, just call 1 (800) 543-7711. We'll fix you up.

**Quark**™  
INCORPORATED

Inquiry 326

2525 West Evans, Suite 220  
Denver CO 80219

Quark and Word Juggler are trademarks of Quark Incorporated. Apple is a registered trademark of Apple Computer, Inc.

Ask about our specially-priced educational version.



text, expectations are generated to hear about an edible object (generally after the word meaning "ingest") and a living actor (generally before "ingest"). Notice that the expectations generated are both semantic (predicting a word or meaning) and syntactic (predicting where the word might be found). Of course, even the CD action may be ambiguous. One way to clear up the ambiguity in such cases is to generate the expectations from both possible meanings and pick the action whose expectations are met by the remaining words in the story. This technique could be used to clarify the meaning of "buy" in the earlier example; "buy" would generate two sets of expectations, one predicting a valuable object and the other predicting an opinion. When one expectation set was satisfied, the program could deactivate the other.

There are many other ways to clear up ambiguities. More complex expectation schemes can provide better information. Consider the restaurant story above. The sentence "The waiter brought it quickly, so he left a large tip" has an ambiguous pronoun, "he." Standard rules for pronoun reference fail here; sex and number don't differentiate, and "he" does not refer to the most recent agreeing antecedent, "waiter." The only way to clarify the meaning of this pronoun is by the expectation that patrons leave tips for servers. You might try associating this information with the appropriate meaning for the word "tip," but patron and server are not just semantic restrictions on slot fillers. John might be a patron in this episode, but he might act as a server in some other situation. The patron/server/tip expectation and the identification of John as a patron must come from a package of expectations about restaurants.

When we began to use packages of expectations in programs, we discovered a few things about packages. First, any story will refer to many packages, and the packages can relate to each other in many different ways. Packages can be grouped together themselves (date = drive, restaurant, drive, movie, drive) or can fill slots in

some other package (the "pay" slot of restaurant might be filled by "wash dishes"). They can occur at the same time (eating and taking an airplane) or be incompatible (driving an automobile and taking an airplane). Packages can also have word senses associated with them. In the restaurant package, "tip" is more likely to mean "money" than "end point." This kind of associated lexicon doesn't solve the problem of ambiguity, but it is a helpful tool.

We also ran into some problems with packages. How could a program figure out which package to use at any given time? It is reasonable to add activation conditions to a package that specify the situations in which that package might be relevant. Early programs just looked at each package to see if its conditions had been met. As the number of packages increased, their organization had to improve. We

needed some way of finding the right set of expectations at the right moment, without looking at every package. As we built programs that used packaged expectations and gave them real stories (taken verbatim from the UPI newswire), we noticed that sometimes expectations failed. These failures were often very interesting events. We began working on ways to determine the difference between a failed expectation and an unresolved one that should be inferred.

Another problem was picking what was to be a package and what wasn't. There are many things about *eating at home* that are like *going to a restaurant*. Do the expectations about eating at home come from the same package or a totally different one? How about eating in different restaurants? We needed a theory of how to organize and find groups of expectations.

(continued)

## NEW AMBER CRT'S

- Eliminates strobe, flicker, and eye fatigue
- Made with Lead/Strontium impregnated glass that stops X-ray emission
- Available in slow decay green or medium decay "European Amber" (the standard in Europe)
- High-contrast double dark face glass that also cuts U.V. radiation
- Tube face is etched to stop glare
- Ideal for word processing and programming, yet fast enough for games and graphics
- Warranted for one full year against manufacturing defects or tube failure

- Comes with a 30 day money back guarantee
- Easily installed (comes with pre-mounted hardware)

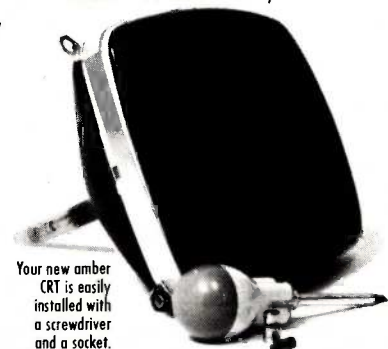

Your new amber CRT is easily installed with a screwdriver and a socket.

Now, you can easily upgrade your monitor to exceed European standards for persistence and color with the installation of a Langley-St. Clair Soft-View™ CRT! Available for the TRS-80™, TeleVideo™, Kaypro™, Heath™, DEC™, Zenith™, IBM PC™, Apple III™ and a wide variety of other monitors.

Call now to order your Soft-View™ CRT from Langley-St. Clair—\$99.95 Plus \$7 for packing and UPS Shipping (\$17 for Overseas, Parcel Post, or UPS Blue Label). Add sales tax where applicable. Visa/MasterCard orders welcomed.

••• Langley-St. Clair  
Instrumentation Systems, Inc.  
132 W. 24th St., New York, NY 10011  
In New York call 212 989-6876

# TO ORDER: CALL 800 221-7070



# 1st PLACE

COMPUTER SYSTEMS  
13422 N. CAVECREEK RD.

PHOENIX, AZ. 85022

OTHER INFORMATION: 602-867-9897



Free shipping is on UPS ground only.

Send cashier's check or money order ..... all other checks will delay shipping two weeks.

Prices & availability subject to change without notice.



Hi - I'm Joan,  
Thank you for the fine response I've had to my ad.

I'd like to mention that prices change very quickly in this business, (keeping in mind that our prices include shipping) so if a price seems high, call me and maybe we can adjust it.

May spring time be the beginning of a beautiful summer for all of you.

Thanks again and God bless

Joan

## FREE SHIPPING

WEST OF MISSISSIPPI  
EAST - 1/2 UPS CHARGES

CALL FREE  
1-800-841-2748

### PRINTERS COMPUTERS

ALTOS 580-20	\$3350
ALTOS 586-20	\$5350
IBM PC	\$CALL
LEADING EDGE PC	\$CALL
NEC 8201	\$329
SANYO 550-555	\$CALL

### TELEVIDEO

803	\$1769	803H	\$2549
1605			\$CALL

ABATI LQ.	\$339
BROTHER HR 25P.	\$655
DAISYWRITER 48K.	\$799
EPSOM	\$CALL
STAR SG10	\$235
JUKI 6100.	\$399
OKIDATA (LOW PRICES)	\$CALL
TOSHIBA 1340P	\$709

### CITOH

8510	\$309	1550P	\$449
F10-40C PS	\$889	F1055	\$1089

### DIABLO

620	\$699	630API	\$1529
-----	-------	--------	--------

### NEC

3550	\$1359	3510	\$1215
7710	\$1635	2030	\$599

### TERMINALS - MONITORS

ALTOS II	\$749
QUME 102G.	\$425
WYSE 50.	\$485
TELEVIDEO 950.	\$895
AMDEK 300G.	\$129
PRINCETON MAX 12	\$165
PRINCETON HX12	\$459

### DISK DRIVES - MODEMS

INDUS APPLE	\$259
INDUS ATARI	\$299
PROMODEM 1200	\$314
PROMODEM 1200B	\$259
PROMODEM 1200A	\$289
SMARTMODEM 1200	\$419
SMARTMODEM 1200B	\$379

## THINKING

Briefly, we began by looking at language. We wanted to generate a program that would read a few sentences and answer questions about them. We have found that, in order to do this, we need to build expectations about the subject matter of the text. Those expectations come from many diverse sources of knowledge and are bundled together into packages. We then have to consider what kinds of packages there are and how we can organize and use them. What began as a study of language has turned into a study of knowledge and knowledge organization—in other words, a study of memory.

### MEMORY

Where do predictions come from? How do we know what to expect next? We use relevant previous experiences to help us understand. Newborns can't comprehend restaurant stories, and people who have worked in restaurants can read more into seemingly insignificant events. We encode what we see in terms of what we have already experienced. That is why two people can see the same event and yet understand it very differently—they each bring different beliefs and expectations to bear. Our ability to understand a situation comes from our ability to compare it to relevant previous situations. The knowledge we gain from experience—episodic memory—is the same knowledge we use to understand—semantic memory.

How does this relate to our prediction packages? The first thing we noticed was that using packages might be an efficient way to remember episodes. Instead of having to store every event in an experience, a program could just save a pointer to the prototype (*restaurant*, for example) along with those parts of the experience that weren't part of the package (for example, the patron was John, the food was a sandwich, the tip was large). Memory need only register those parts of an episode that differentiate it from the prototype. Since packages contain what we expect in a situation, they are effectively pro-

totypes; hence, they can serve to organize memory of events. Our packages now have another role to play: They should accomplish the functions of event memory as well as provide the expectations that aid in understanding.

If packages are to function as memory as well as processing structures, they have additional requirements. First and foremost, a memory system must be dynamic. The memory must be altered by its experiences. A memory system that fails to respond to new inputs and learn from its experiences is not very useful. A memory system that produces expectations must be able to respond to expectation failures by reorganizing itself to provide better expectations in the future. Second, a memory system must be able to find what it knows. This may not seem very hard, but it is. The task of memory is to take a given event and find related events. But what constitutes a "related" event, and how do we know where to look for one? These two goals—remembering and learning—drive our theorizing about the structure of memory. We need to understand how knowledge is structured and how it can change.

We also have a powerful technique with which to investigate the structure of human memory: reminding. Reminding is a ubiquitous phenomenon; people are constantly reminded of one thing by another. You can be reminded of an object, a person, or a situation. In the course of normal conversation, people are often reminded of previous events. During the mental processing of that conversation, some memory is activated to help understand the new input. The fact that one experience reminds us of another indicates that we are using the same structure to process one as to remember the other. By examining the process of reminding, we can explore the structure of memory.

Armed with our new conception of memory structures, let's return to our restaurant example. Suppose that when John received the bill, the waiter

(continued)



# Innovation

A modem that  
won't let your computer  
talk to strangers.

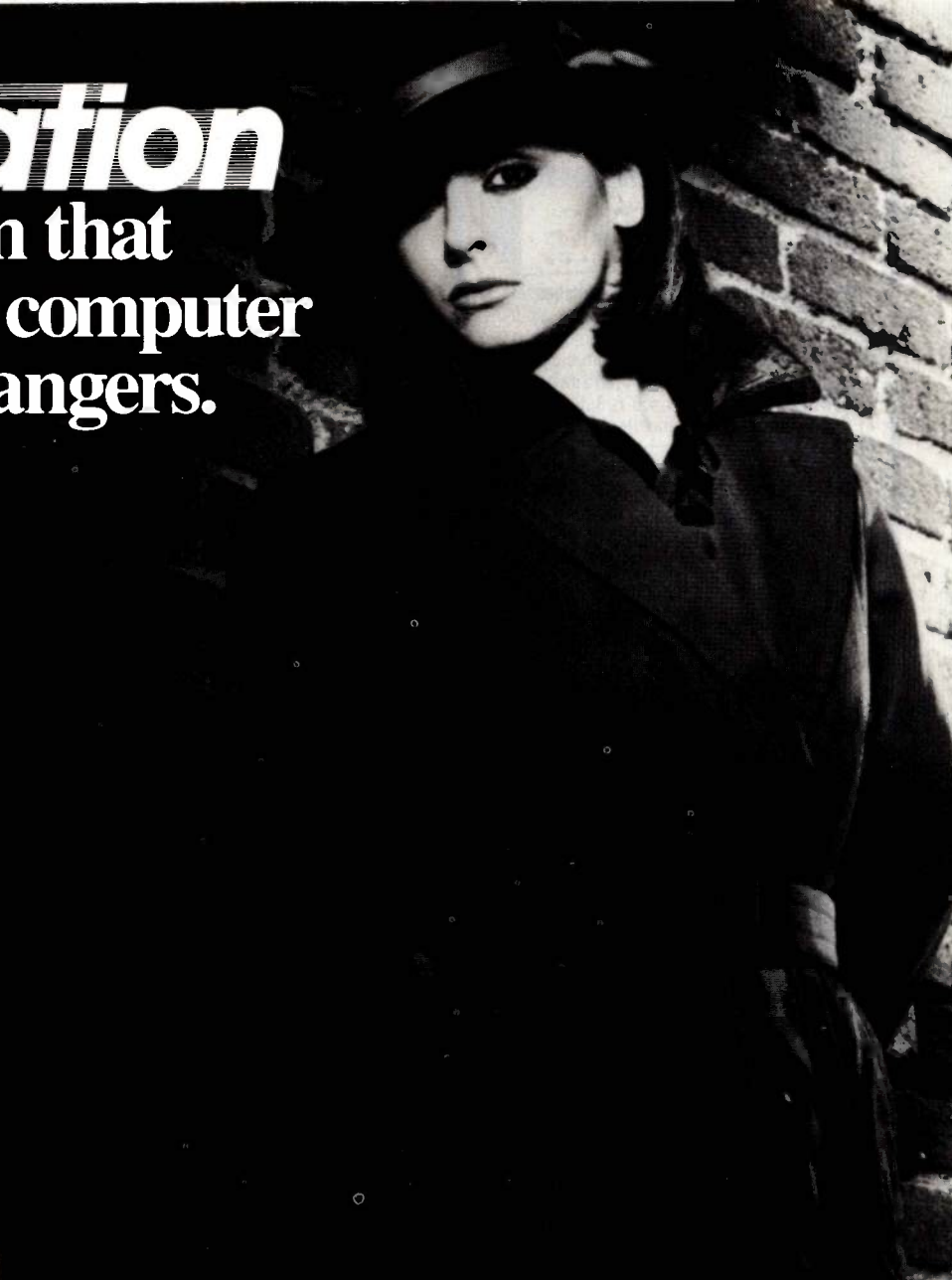

© Lockheed-GETEX 1985

## GTX-100. Computer security so advanced, it could even foil Mata Hari.

If the World War I spy Mata Hari were around today, she'd probably be into computers. Maybe into yours.

Computer espionage is a growing threat these days. With just one phone call, a thief can tamper with data stored in your computer: confidential correspondence, meeting transcripts, employee records, and privileged client files.

Computer intruders can

steal information like that. Or erase it. Or alter it to their advantage.

That's why your computer needs the protection of GTX-100. It's a new kind of security subsystem developed from Lockheed's years of experience with high technology and strict security.

GTX-100 puts an electronic wall around your sensitive files and prevents your computer from talking to strangers.

Send us the coupon for more information plus the name of your nearest dealer or distributor. He can demonstrate why GTX-100 won't yield your secrets to even the cleverest of computer spies.

### Mail to:

Lockheed-GETEX, Suite 945,  
1100 Circle 75 Parkway, Atlanta,  
GA 30339. (404) 951-0878.

### Please send me:

- GTX-100 brochure.
- The name of my nearest dealer/distributor.

Name \_\_\_\_\_

Title \_\_\_\_\_

Company Name \_\_\_\_\_

Address \_\_\_\_\_

City \_\_\_\_\_ State \_\_\_\_\_ Zip \_\_\_\_\_

 **Lockheed-GETEX**  
Giving shape to imagination.



# Multi-function RS-232 Switches

MFJ-1240  
\$ 79 95  
Choice of  
8 models

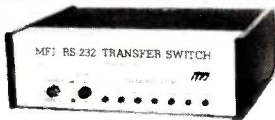

Multi-function RS-232 transfer switches let you switch your computer among printers, modems, terminals, any RS-232 peripherals; monitor data/line failure, protect data lines from surges, and use as null modem for less cost than a switch alone.

**Switches 10 lines** (2, 3, 4, 5, 6, 8, 11, 15, 17, 20). LED data/line indicators monitor lines 2, 3, 4, 5, 6, 8, 20. Metal oxide varistors protect data lines 2, 3 from voltage spikes and surges. Push button reverses transmit-receive lines (2,3). PC board eliminates wiring, crosstalk, line interference. Connects any one input to any one output.

Model	Price	In	Out	Model	Price	In	Out
MFJ-1240	\$79.95	1	2	MFJ-1244	\$139.95	3	3
MFJ-1241	\$99.95	2	2	MFJ-1245	\$169.95	3	5
MFJ-1242	\$119.95	2	3	MFJ-1246	\$199.95	5	5
MFJ-1243	\$119.95	1	4	MFJ-1247	\$99.95	1	2

switches 20 lines

# Printer Switch for IBM PC Computer

MFJ-1248  
\$ 99 95



Share a parallel printer between 2 IBM PCs with the push of a button. Eliminate trouble and confusion caused by re-routing cables. Save the cost of a second printer. Features 3 female connectors like those on the IBM PC parallel printer port.

Quality PC board construction eliminates wiring, crosstalk and line interference. All lines switched. Printer switch is bi-directional. 8x2x6 inches.

# Parallel Printer Switch

MFJ-1249  
\$ 99 95



2 in, 1 out, bi-directional switching. All lines switched except 15, 18 and 34. PC board construction. 3 female Centronics type connectors. 10 1/2x2x6 inches.

# AC Power Centers

MFJ-1108 MFJ-1108, \$99.95. Add conven-

ience, prevent data loss, head bounce, equipment damage. Relay latches power off during power transients. Multi-filters isolate equipment, eliminate interaction, noise, hash. MOVs suppress spikes, surges. 3 isolated, switched socketpairs. One unswitched for clock, etc. Lighted power, reset switch. Pop-out fuse. 3 wire, 6 ft. cord. 15A, 125V, 1875 watts. Aluminum case. Black. 18x2 1/4x2 in. MFJ-1107, \$79.95. Like 1108 less relay. 8 sockets, 2 unswitched. MFJ-1109, \$129.95. Like 1107 but intelligent. Switch on device plugged into control socket and everything else turns on. Others available.

Order from MFJ and try it. If not delighted return within 30 days for refund (less shipping). One year unconditional guarantee.

Order yours today. Call toll free 800-647-1800. Charge VISA, MC or mail check. money order for amount indicated plus \$4.00 each shipping.

**CALL TOLL FREE... 800-647-1800**

Call 601-323-5869 in Miss. outside continental USA, tech/repair info. Telex 53-4590 MFJ STKV

Write or Call for FREE Catalog!

**MFJ ENTERPRISES INCORPORATED**

921 Louisville Rd., Starkville, MS 39759

## THINKING

*Common sense is knowing about a lot of things and using what you know in a variety of situations.*

had made an arithmetic error and charged him too much. John noticed this and complained. The waiter was apologetic and not only fixed the error but offered John a free dessert. John—or any dynamic memory system trying to understand what is happening—should record this deviation from the expected routine. If he were later to notice a similar error while buying auto parts, he might be reminded of his experience in the restaurant. He might then expect compensation from the store to make up for the mistake. How can an experience in an auto-parts store remind you of an experience in a restaurant? There must be some memory structure that is used to understand both experiences. In addition, by storing information about expectation failure (and its results) in the shared structure, we automatically make an appropriate generalization.

What does this tell us about the organization of memory? Surely not all the expectations are the same across these events; John doesn't expect to see a menu or be served a lobster dinner in the auto-parts store. But some expectations are indeed the same: He expects to find out what is available, to tell someone what he wants, to receive it, to get a bill for what he has ordered, and to pay the bill. Some major scenes happen in one event and not in the other; there is no equivalent to being directed to a table by a hostess in the auto-parts store. Also, the specifics added to the generalized scenes are different. For example, in an auto-parts store you find what you want by looking through fat catalogs of numbered

parts sorted by model and year; in a restaurant, you look at the menu.

We can draw several conclusions about memory structures. Packages are nested, that is, packages have sub-packages. In AI terminology, the packages are called MOPs (for memory organization packages), and the sub-packages, scenes. Scenes are shared—most appear in many MOPs. Examples of scenes might be *pay* and *order*. It is important to note here that there is no "correct" list of packages. The packages that any dynamic memory system uses at any particular time depend on its own prior experiences. Furthermore, a MOP contains information about the specific details of its own scenes. These details are called *colorations*; for example, the restaurant MOP might color the pay scene by specifying the acceptable types of payment in a restaurant (cash, credit, dishwashing, etc.).

The ability to share scenes provides a mechanism for making useful generalizations. When there is an expectation failure and the source of the expectation is part of a shared structure, the failure and any new expectations based on that failure are stored in that structure. When a similar situation occurs, even in a different package, the previous failure comes to mind (is reminded) because it is stored in the shared scene. Then it can be used to help guide processing. A program using this system might learn to count its change in the auto-parts store after being shortchanged in the restaurant, since both use the pay scene. This combination of failure-driven learning and shared memory structures is quite powerful. Expectation failure can also be used to build new MOPs from old ones by changing the colorations or the order of scenes (for example, in fast-food restaurants, you pay before you eat).

Many more kinds of memory and processing structures are used in our AI theories and programs than we can describe here, but the basic requirements of a useful memory organization should be clear. (For more information, see references 2 and 3.) What

(continued)



# MULTI-USER REQUEST: THE DBMS THAT MAKES GREAT MINDS THINK ALIKE.

Now there's multi-user software to go with your multi-user hardware—including the new IBM PC/AT.®

Now there's reQuest.

reQuest is the database management system that can support just one PC, or an entire Local Area Network.

It gives your top managers the individual computing power to build high-performance applications. Plus the networking power to share their thoughts with your company's other great minds.

**No executive is an island.**

Think of the possibilities:

When everyone shares the same database, decision-making becomes more consistent, company-wide.

Sales can keep in touch with Production.

Property can compare notes with Finance.

Reports will be more accurate.

Strategies will be more cohesive.

And you'll finally realize the full potential of your executive PCs.

**Proven, guaranteed performance.**

reQuest has been proven in hundreds of major government and business applications.

It works with a wide variety of hardware, including IBM PC® and PC compatibles, Burroughs, A. B. Dick, NCR, Hewlett-Packard, and many others.

It has the capacity to download information from your mainframe, process it, and send it back. And the versatility to serve as the foundation for dozens of popular programs, including LOTUS 1-2-3,™ Multiplan,® and WordStar.®

Yet, its menu-driven format is so easy that even the most computer-shy managers can quickly build and operate their own applications. And reQuest is backed by full money-back satisfaction guarantee.

**Request reQuest, today.**

Call or write now for a free brochure or our \$9.95 sample diskette: **1-800-321-DBMS.**

You'll see how much more your company can do when you connect with reQuest.

## reQuest®

### POWER TO SHARE

System Automation Software, Inc.  
8555 Sixteenth Street, Silver Spring, MD 20910  
301-565-9400

Inquiry 376

Trademark Acknowledgements:

IBM, PC, and PC/AT: International Business Machines Corp.,  
A. B. Dick: A. B. Dick Company, Burroughs: Burroughs Corporation,  
Hewlett-Packard: Hewlett-Packard Co., NCR: NCR Corp.,  
Lotus and 1-2-3: Lotus Development Corp., Multiplan: Microsoft Corp.,  
WordStar: Micropro Corp. reQuest is a trademark of System Automation Corporation.

© 1984 System Automation Software, Inc.





## TOUGH LOCAL NETWORK PROBLEM:

"How can our department get our six computers and three printers to work together efficiently? We also want to be able to access outside data services and our future company LAN."

## SIMPLE \$2995\* SOLUTION: NetCommander

NetCommander is a smart, small Local Area Network manager. It lets you link from four to 40 computers and peripherals — in any mix of models and makes. A 50K buffer (expandable to 250K) makes sure that productivity is high — keeping fewer printers humming — while computer and PC users do their thing, without waiting for a printer, modem, or shared disk. Those devices can be specified with names defined by users — and allocated on the basis of availability and capability. And NetCommander handles multiple protocols and different baud rates simultaneously — without modifications to hardware or software. It will also tie into your company's LAN. The latest in a family of products in use since 1979, NetCommander is a smart, small, efficient network manager.

For more information, call or write:

## NetCommander

Digital Products Inc. • The Simple Network Solution Company  
600 Pleasant Street • Watertown, MA • 02172  
(617) 924-1680 • Outside Mass., call 1-800-243-2333  
And check out our 30-day trial evaluation.

\*For 16 ports

## SuperSoft Programmer Utilities When Performance Counts

## Star-Edit and Disk-Edit

Star-Edit is the professional programmer's text editor with an outstanding list of commands tailored to program development. It can greatly simplify all your editing tasks — moving and reproducing text or code, viewing two files simultaneously through separate windows, moving text or code between different files, searching forward or backward, and moving to the beginning or end of any word, sentence, paragraph, parentheses, or curly brackets. Virtual memory makes Star-Edit ideal for extremely large files; and because it never uses over 128K, it is well suited for multiple process and windowing environments. (PC DOS, MS DOS, CP/M-86, CP/M-80, UNIX, or XENIX): \$225.00

To order call: 800-762-6629  
In Illinois call: 217-359-2112  
or write to SuperSoft.

Disk-Edit is the uniquely powerful disk utility for programmers which gives you access to every bit of information on your disk. It lets you read disk data in both HEX and ASCII, "text edit" any information on your disk, restructure disk information, and save lost or scrambled data. Imagine scrolling through your disk data, jumping between HEX and ASCII windows, and editing information anywhere on your disk. For all floppy and hard disk systems. (PC DOS, MS DOS, CP/M-86, CP/M-80, UNIX, or XENIX): \$100

## SuperSoft

1713 S. Neil St., P.O. Box 1628  
Champaign, IL 61820  
telex:270365

## THINKING

may not be clear is how important memory and its organization are to nearly all cognitive activity. Getting just the right piece of knowledge at the right moment from our huge and constantly changing memory is not only crucial for language understanding but crucial for exhibiting common sense (which is really just knowing about a lot of things and being able to use what you know in a variety of situations), for applying expert knowledge, for writing interesting stories, and for accomplishing a host of other tasks. Being able to learn from experience and apply that knowledge in relevant situations is an important step toward actual intelligence.

### WHAT IS AI?

The term "artificial intelligence" has been much abused of late, and we would like to try to clarify what we mean by it. Programs that manifest theories of knowledge do interesting, sometimes even impressive feats. But many programs that are not attempting to model cognition also do impressive things. The public perception of AI has focused on the *artificial*. Computers are indeed doing things we never imagined machines could do. Computer scientists and engineers are constantly expanding the usefulness and power of their machines. That is important science and engineering, but it is not AI. AI focuses on *intelligence*, something that remains mysterious and elusive. Most good AI programs aren't terribly useful, and many very useful, "smart" programs aren't AI at all. If this distinction were understood, we could avoid a lot of confusion and disappointment.

So-called expert systems are a case in point. These programs, more accurately dubbed "rule-based," do not attempt to reason the way a human expert would. They often do very useful tasks, and that's great, but they are not model theories of intelligence. A human expert is not someone who is just following the rules. He has the *experience* to know when he is seeing an exceptional case, and he can recall relevant past cases to help him figure

(continued)



Resource Technology — What's it all about?

# IT'S ABOUT TIME!

...and Time is relative. In business, time is profitability!

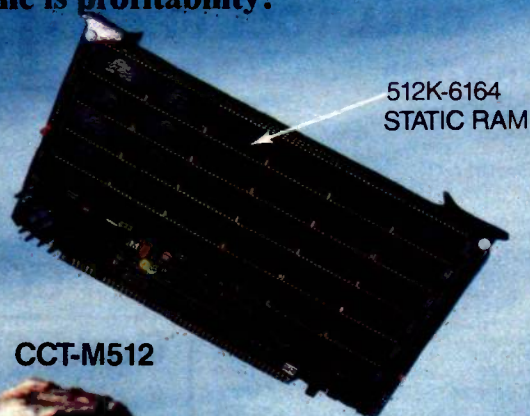
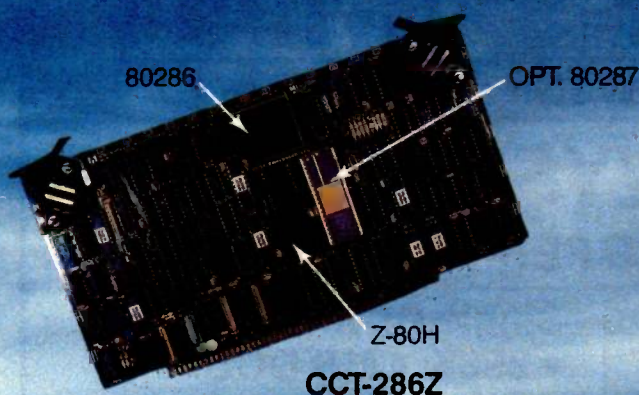

Given enough time, an end result of the desired quality may be finally attained - (see natural examples). In business, however, the bottom line is directly proportionate to the quality of, and the time consumed by, the tools employed - (see digital examples).

CCT teams up with MACROTECH to bring these ultimate speed and power tools to the serious business/scientific market. State-of-the-art processors, with super high-speed/high-density memory boards, form the basis for CCT machines with bottom-line computing power PCs can't touch.

## CCT Implements Tomorrow's Technology Today!

Join some of the serious CCT clientele: U.S. Dept. of State, Uniroyal, Miles Labs, Univ. of Massachusetts, UCLA, Teledyne Semiconductor, UC Berkeley, U.S. EPA, Proctor & Gamble, MIT, Lockheed, Corps of Engineers, U.S. Navy, U.S. Coast Guard, Jet Propulsion Labs, Hallmark, McGraw-Edition, Sperry, International Paper, 3M, Beech Aircraft, LSI, Eastman-Kodak, Western Electric, Nat'l. Bureau of Standards, USC, Cornell University, British Cable and Wireless, USAF, and thousands more, worldwide.

For further details, see our technical ad on page 449 of this issue, or contact our technical staff at (602) 282-6299. For system quotations and ordering only, call our sales building at (800) 222-8686.

**CUSTOM COMPUTER TECHNOLOGY / 1 CCT PLAZA / SEDONA, AZ 86340**

Photograph: Sedona's famous Red Rock Crossing, taken with Nikon FE-2 and Nikkor 35-105mm lens, at 40mm, at f11-1/60th, with special Kodak 5294 movie film-ASA 320.



# COMPUTER WAREHOUSE

CALL TOLL FREE **1-800-528-1054**

## PRINTERS

<b>Anadex</b>	
9625B	\$1129
WP6000	\$2039
DP6500	\$2259
<b>Brother</b>	
DX-15	\$ 355
DX-15XL	\$ 365
HR-25	\$649
HR-35	\$875
<b>C-Itch</b>	
A-10-30	\$459
F-10 Parallel or Serial	\$859
55 CPS Serial or Parallel	\$1019
8510 Parallel (Prowriter)	\$299
8510 SP	\$385
8510 SCP	\$459
8510 BPI	\$309
<b>Comrex</b>	
CR-2E	\$ 375
CR-4	Call
420	Call
<b>Datasouth</b>	
DS180	\$1089
DS220	\$1315
<b>Diablo</b>	
620	\$694
630 API	\$1499
630 ECS	\$1669
630 ECS/IBM	\$1669
Series 36	\$1139
80 IF	\$2649
P12CQI	\$529
P32CQI	\$759
S32CQI	\$839
P38	\$1639
S38	\$1719
C150	\$999
<b>Epson All Printer Models</b>	Call
<b>Inforunner</b>	
Riteman w/Tractor	\$244
Riteman 15	\$499
Riteman Blue w/Tractor	\$299
<b>Juki</b>	
5500	Call
6100	\$385
6300	\$699
<b>NEC</b>	
2010, 2015, 2030	\$639
2050	\$669
3510, 3515, 3530	\$1215
3550	\$1359
8810, 8815, 8830	\$1665
8850	\$1779
P2, P3	Call
<b>Okidata All Printer Models</b>	Call
<b>Panasonic</b>	
1091	\$265
1092	\$395
1093	\$595
KXP3151	\$459
<b>Silver Reed</b>	
EXP400	\$235
EXP500 Parallel or Serial	\$289
EXP550 Parallel or Serial	\$399
EXP770 Parallel or Serial	\$689
<b>Star Micronics</b>	
All Printer Models	Call
<b>Tally</b>	
Spirit 80	\$245
<b>Toshiba</b>	
P1340 Parallel or Serial	\$665
P1351 Parallel or Serial	\$1165
<b>PLOTTERS</b>	
<b>Enter</b>	
Sweet-P600	\$780
<b>BOARDS</b>	
<b>AST</b> Six Pack Plus	\$259
<b>Paradise</b>	
Modular Graphic 06-1	\$275
Five Pak	\$159
<b>DISKETTES</b>	
<b>Maxell</b>	
MD-1 (Qty 100)	\$175
MD-2 (Qty 100)	\$199
<b>KEYBOARDS</b>	
<b>Keytronics</b>	
5151	\$179
5151 Jr.	\$179

\*\*\* YOUR WYSE CHOICES \*\*\*

## WYSEpc

### IBM-COMPATIBLE PERSONAL COMPUTER

**Dual Drive**

- 256K • MS DOS
- GW Basic

**Single Drive - 10 Megabyte**

- 256K • MS DOS
- GW Basic

Wy-500 Green Monitor • Wy-600 Color Monitor • Wyse 50 • Wyse 75

# SAVE UP TO 30%

## VIDEO TERMINALS

<b>ADDS</b>	
A-2 Green	\$469
A-3	\$469
<b>Altos</b>	
Smart II	\$699
<b>Qume</b>	
QVT 102 Green	\$399
QVT 102 Amber	\$419
QVT 103 Green	\$816
QVT 103 Amber	\$850
QVT 108 Green	\$449
QVT 108 Amber	\$519
<b>Televideo</b>	
800	\$1225
800A	\$ 979
910	\$ 425
910+	\$ 559
921	\$ 449
922	\$ 755
924	\$ 639
925	\$ 699
925E	\$ 599
<b>Wyse</b>	
50	\$489
75	\$565
<b>Zenith Z-22</b>	\$469
Z-29	\$599
Z-49	Call

## MODEMS

<b>Anchor Automation</b>	
Anchor Express	Call
Mark XII	\$239
<b>Hayes</b>	
Smartmodem 300 Baud	\$190
Smartmodem 1200 Baud	\$455
Smartmodem 1200B (IBM)	\$385
Micromodem IIE (Apple)	\$219
<b>Novation</b> Smart Cat Plus	\$315
<b>Prometheus</b> All models	Call
<b>Racal-Vadic</b> All Models	Call
<b>US Robotics</b> Password 1200	\$219

## COMPUTERS

<b>Altos</b> All Computer Models	Call
<b>Columbia</b>	Call
<b>NEC</b>	
PC-8201 Computer	\$315
PC-8201A-90 Battery Pack	\$15
PC-8206A 32K Ram	\$215
PC-8271A-01 AC Adapter	\$16
PC-8271A-02 AC Adapter	\$16
PC-8281A Recorder	\$89
<b>Northstar</b>	
All Computer Models	Call
<b>Sanyo</b> MBC-775 Portable	Call
MBC-550 System	Call
MBC-555 System	Call
MBC-550-2 System	Call
MBC-555-2 System	Call
MBC-885	Call
<b>Televideo</b>	
803	\$1915
804	\$3429
1605D	\$1909
1605C	\$2299
1605H	\$3459
1605CH	\$3549
TPC-1	\$755
TPC-2 Single Drive	\$1509
TPC-2 Dual Drive	\$1749
<b>Visual</b> Commuter	From \$1469
<b>Zenith</b>	
Z-150 Single Drive	Save 25%
Z-150 Dual Drive	Save 25%
Z-150 W/10 Megabyte	Save 25%
Z-160 Single Drive	Save 25%
Z-160 Dual Drive	Save 25%
<b>TEC MAR</b>	
Graphics Master	\$449
126K Dynamic Memory	\$225
256K Dynamic Memory	\$299
Captain 128K	\$299
Captain 256K	\$399

## MONITORS

<b>Amdek</b> All Monitors	Call
<b>Princeton Graphic</b> HX-12	\$479
<b>Sanyo</b>	
CRT-30	\$99
CRT-36	\$149
CRT-50	Call
CRT-70	\$549
<b>Taxan</b>	
121 Green	\$125
122 Amber	\$134
420 RGB	\$399
425 RGB/Green	\$410
<b>Zenith</b>	
ZVM-122 Amber	\$95
ZVM-123 Green	\$95
ZVM-124	\$129
ZVM-130	Call
ZVM-133 Color/RGB	\$410
ZVM-135 Color/RGB W/Audio	\$459
ZVM136	\$575
<b>DISK DRIVES</b>	
<b>Alpha Omega</b> Turbo 10	\$739
<b>Iomega</b>	
Bernoulli Box for IBM	
10 Megabyte	\$1950
20 Megabyte	\$2660
<b>Rana</b>	
Elite I	\$179
Elite II	\$339
Elite III	\$405
Elite 10H/Apple	\$1080
Controller (W/Drive Only)	\$69
1000 W/DOS for Atari	\$305
<b>Tallgrass</b>	
TG-3020	\$2289
TG-3135	\$3689
TG-4060	\$1469



Order Line: 1-800-528-1054 Order Processing & Other Information: 602-954-6109

2222 E. Indian School Rd.  
Phoenix, Arizona 85016

Store Hours: Mon-Fri 10-5:30 Saturday 9-1  
Order Line Hours: Mon-Fri 8:30-5:30 Saturday 9-1



Prices reflect 3% to 5% cash discount. Product shipped in factory cartons with manufacturer's warranty. Please add \$8.00 per order for UPS shipping. Prices & availability subject to change without notice. Send cashier's check or money order... all other checks will delay shipping two weeks.



out what to do. AI theories of expert behavior must describe how an expert knows when something doesn't fit his general rules and what to do about it. AI theories need to account for how experts change and add to the rules they use, based on the success or failure of those rules.

Artificial intelligence is a much more basic science than is popularly believed. Many of our best AI ideas require a great deal of work before they can become useful applications. And when an AI idea is turned into a useful system, in some sense it isn't AI anymore. The construction of such a system requires all kinds of non-AI programming effort—to make the idea work in a real environment, on real computers, in some useful way. Such a system is made possible by the AI idea, but the program's merit comes from its functionality, not its heritage. The fact that a program is based on an AI idea is no way to judge its functionality.

Are there any applications of AI? We think so. If we are gaining insights into how people think, then our findings should help people think better. Perhaps AI's most important applications will not be the programs that we write but the newfound ability to understand how people think. As we find out more about how people read, understand, and create, we may be able to help them do those things better. Perhaps AI's most promising applications are in education—helping to teach people how to read, remember, and think based on a fundamental knowledge of those processes.

Let's consider the problem of teaching children—or adults—to read. In trying to write programs that can read, we have learned a great deal about the reading process. Perhaps we can transfer some of this into improved techniques for teaching reading. Of course, this is not always a straightforward task, but we believe it is possible. Expectations play a central role in understanding text. As children build up expectations about words and stories, they become better readers. Language ability is strongly tied to knowing the content of the

material, so the books children read should relate to what they know. We may be able to write better reading textbooks by using expectation packages that children know about. We can write textbooks that encourage them to use their knowledge to fill in the details behind the text, to make inferences. Since AI has focused on language for most of its existence, it has a lot to contribute to reading education. But that's not all AI has to offer; its promise extends throughout education and beyond. AI should eventually provide insights into how to learn and remember better, how to improve explanatory faculties, and even how to extend creativity.

Artificial intelligence is part of the grand attempt to understand thinking. We believe it is making important contributions to that endeavor, and that is the goal of our science. The programs we write are experiments, not

results. Our interest is intelligence, not artifact. As we make progress, our results may prepare the way for the automated companions that could become an indispensable part of everyday life. These will not be our real results, though. The real results will be a new kind of understanding of ourselves, an understanding that is ultimately much more valuable than any program. ■

REFERENCES

1. Schank, Roger C. *Conceptual Information Processing*. Amsterdam: North-Holland, 1975.
2. Schank, Roger C. *Dynamic Memory: A Theory of Reminding and Learning in Computers and People*. Cambridge: Cambridge University Press, 1982.
3. Schank, Roger C., and Christopher K. Riesbeck. *Inside Computer Understanding: Five Programs Plus Miniatures*. Hillsdale, New Jersey: Lawrence Erlbaum Associates, 1981.

## Robotic Development System Using IBM PC/Apple IIe

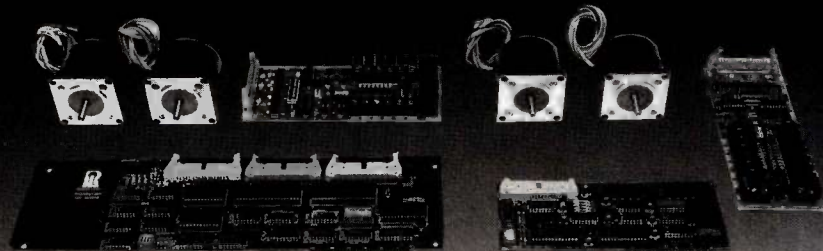

**Complete 2 axis systems using 2 size 23 stepper motors with R2D23 dual-axis driver; cable & powerful system software, expandable to 4 axis.**

**IBM PC/XT Version \$792      Apple II/IIe Version \$420**

- 1 432 I/O stepper controller
- A6 T/D stepper controller
- 32 digital I/O
- 32 digital I/O available

Digital I/O accessories, power supply and higher power size 34 stepper motor system are available.

**ROGERS LABS**

2727-E So. Croddy Way, Santa Ana, CA 92704

(714) 751-0442

TELEX 681393



COMPROY

TELEX 910 380 3980

ALL MAIL: 12060 SW Garden Place, Portland, OR 97223

FOR YOUR APPLE

Table with columns: COMPUTERS, SYSTEMS IN STOCK, FLOPPY DISK DRIVES, HARD DISKS, OTHER HARDWARE. Includes Apple logo and various computer models like MICRO-SCI, TEAC, RANA, VIDEO TECH, QUARK, CCS, KENSINGTON, KEY TRONIC, KOALA, M&R, MICROSOFT, ORANGE MICRO, PAYMAR, RH ELECTRONICS, TITAN.

Table with columns: OTHER HARDWARE, TRACKHOUSE, CENTRAL POINT, CONROY-LAPOINTE, CONTINENTAL, CREATIVE SOLUTIONS, DOW JONES, HAYDEN, HUMAN EDGE, KENSINGTON, LIVING VIDEOTECH, LOTUS, MAIN STREET, MAXELL, MEGAHUS, MICROSOFT, MILES, MONOGRAM, NOVATION, ODESTA, PENGUIN, PROMETHEUS, PROVUE, SCARBOROUGH, SIMON & SCHUSTER, SOFTW. PUB., STONEWARE, TELOS, T/MAKER, VIDEK.

Table with columns: BUSINESS SOFTWARE, LIST PRICE, CONROY PRICE. Includes software like ALS, APPLIED SOFT TECH, ARKRONICS, ARTSCI, ASHTON-TATE, BPI, BRODERBUND, CONTINENTAL, CDEX, DOW JONES, HAYDEN, HUMAN EDGE, LIVING VIDEOTECH, MECAHUS, MICRO PRO, MICROSOFT, OSBORNE COMIX, PEACHTREE, QUARK, SIERRA, SIMON & SCHUSTER, SOFTWARE PUBL., STONEWARE.

Table with columns: UTILITIES SOFTWARE, LIST PRICE, CONROY PRICE. Includes software like BEAGLE, BORLAND, CENTRAL POINT, EINSTEIN/ALISON, EPSON, FUNK, HAYES, MICROSOFT, OMEGA, PENGUIN, PHOENIX, QUALITY, UNITED SWI, UTILICO. Also includes HOME & EDUCATIONAL and RECREATIONAL SOFTWARE sections.

Table with columns: DISKETTES, CONROY-LAPOINTE, GENERIK. Includes various diskette products like CONROY-LAPOINTE, CDC, DYSAN, MAXELL, MEMOREX, VERBATIM.

Table with columns: MODEMS, MONITORS, AMDEK, PRINCETON, QUADRAM, ZENITH. Includes modem and monitor products like ANCHOR, HAYES, PROMETHEUS, QUADRAM, VENTEL, AMDEK, PRINCETON, QUADRAM, ZENITH.

Table with columns: PRINTERS, DOT MATRIX, LETTER QUALITY, PLOTTERS, PRINTER SUPPLIES. Includes printer products like EPSON, FX80, JUKI, TOSHIBA, TTX, AMDEK.

Table with columns: PRINTER INTERFACES & BUFFERS, CABLES, ACCESSORIES. Includes printer interfaces, cables, and accessories like ARBO, EPSON, ASSIM, KPC, OKIDATA, ORANGE MICRO, PRACTICAL, QUADRAM, ARBO, CURTIS, EPD, INNOVATIVE, PERFECT DATA, PROD TECH INT'L.

Form for CONROY-LAPOINTE CREDIT CARD, including fields for name, address, city, state, zip, and phone number.

ORDERING INFO & TERMS: MAIL TO: 12060 SW Garden Place, Portland, OR 97223. Includes shipping, handling, and return policies.



# -LA POINTE INC. SM

#B16

© 1984 by Conroy-LaPointe, Inc. All Rights Reserved

**ORDER NOW (800) 547-1289**

**FOR YOUR IBM-PC, XT, AT or JR**

**SAVE 25% - 75% OFF LIST !!!**

### COMPUTER SYSTEMS

— Call for Details —

## 256K IBM - PC

360K Disk Drives by CDC

90 Day Limited Warranty By Us



**SANYO 555-2**  
256K, 2 320K Disk Drives

**ZENITH Z150**  
256K, 2 320K Disk Drives.  
MS DOS 2.1, 8088 Chip, 2 S/P

### HARD DISKS

Kits are completely engineered to work with DOS 2.0/2.1. Easy to install. Includes Hard Disk, Controller Card and Instructions.

	LIST PRICE	CONROY PRICE
<b>KAMERMAN</b> , External 10 meg kit	\$1295	\$1095
MegaLight 100, Internal 10 meg kit	\$895	\$795
Masterlight, 20 meg, tape, surge prot.	\$3095	\$2495
<b>MAYNARD</b> , Internal 10 meg kit, (W/S)	\$1595	\$1150

**QUADRAM**, Quaddisks Int. w/controller, Full Line

	LIST PRICE	CONROY PRICE
<b>RANA</b> , External 10 meg w/controller	\$1495	\$1095
Internal 10 meg w/controller	\$995	\$795

### FLOPPY DISK DRIVES

CDC, Limited 90 day warranty. Call for quantity prices.

	LIST PRICE	CONROY PRICE
Full Height	\$149	
Half Height	\$129	

**MAYNARD**, Controller Card w/para port \$300 \$185  
Controller Card w/serial port \$310 \$195  
Sandstar Cont Card (accepts 3 modules) \$265 \$205  
**PERFECT DATA**, Head Cleaning Kit \$16 \$12

### OTHER HARDWARE

AST	LIST PRICE	CONROY PRICE
SixPak Plus, 64K	\$245	
SixPak Plus, 256K, S/P/CC+S/W	\$695	\$395
SixPak Plus, 384K, S/P/CC+S/W	\$895	\$465
Game Port for SixPak	\$50	\$39
Preview™ Graphics Card w/para. 64K	\$399	\$299
Advantage™, Multit. Bd for AT	\$595	\$445
I/O Plus II, S/P/CC	\$215	\$150
I/O Plus II, S/P/CC/G	\$265	\$185
I/O Plus II, 2S/P/CC/G	\$315	\$215
MonoGraphPlus™ P/CC (for Lotus)	\$495	\$375
PCNet, Starter Kit, PC002	\$1090	\$790
PCNet, Circuit Board, PC001	\$695	\$365
ComboPlus Products in STOCK		<b>CALL CALL</b>
MegaPlus Products in STOCK		<b>CALL CALL</b>
<b>COMX, NEW</b>		
Econo RAM Plus™, 384K to 1.5 meg board, S/P/CC/G, Fastrak™ & Spooler	\$595	\$325
EconoRAM™, full 384K board	\$50	\$30
<b>CURTIS</b> , UNI-I, Monitor (lit/swivel) base	\$50	\$39
3-9 foot Keyboard Extension Cable	\$40	\$30
<b>HAUPPAGE (HCW)</b> , 8087 Chip	\$175	\$149
8087 Math Pak (Chip & Softw)	\$295	\$235
8087 Software Pak	\$180	\$138
8087 Math Pak	\$245	\$185
<b>HAYES</b> , Mach II Joystick	\$45	\$29
<b>HERCULES</b> , Color Card w/para. Mono Graphics Card	\$245	\$169
<b>KAMERMAN</b> , External Power Supply	\$499	\$329
<b>KENSINGTON</b> , Masterpiece™ PC Saver™ Line Cord w/Filter	\$395	\$295
<b>KEY TRONIC</b> , KB5151, Std. keyboard	\$255	\$159
MS150, Std. keyboard	\$200	\$159
<b>KOALA</b> , Speed Key System	\$100	\$63
Speed Key Tables w/software	\$200	\$139
Koala Pad™ w/PC Design Programmer's Guide	\$150	\$89
\$15	\$14	
<b>MAYNARD</b> , SAND STAR SERIES		
Multifunction (6) Card	\$89	\$79
Memory Card RAM	\$189	\$169
Memory Card 256K	\$495	\$395
Floppy Cont. Card, accepts 3 modules	\$265	\$205
HardDisk I/F Module	\$499	\$399
HardDisk Cable	\$30	\$27
Serial Port Module	\$95	\$79
Para or Clock Cal. Module, ea	\$59	\$49
Game Adapter Module	\$49	\$39
Memory Module, DK	\$99	\$79
Memory Module 256K	\$422	\$357
10 meg Hard Disk Kit & Cont Card	\$1595	\$1150

### OTHER HARDWARE

	LIST PRICE	CONROY PRICE
<b>MICROSOFT</b> , Mouse for PC	\$195	\$139
System Card, 64K	\$395	\$275
System Card, 256K	\$625	\$450
<b>MOUSE SYSTEMS</b> , PC Mouse & Pant	\$295	\$199
<b>PARADISE</b> , Modular Graphics Card	\$395	\$285
Parallel or Serial Port, ea	\$95	\$65
<b>PERSYST, NEW</b>		
PC/Mono Board, w/para port	\$250	\$195
PC/Color Graphics Bd w/light pen & I/F	\$244	\$176
BOB Board™ Color Adapter, hi res	\$595	\$465
<b>PLANTRONICS</b> ,		
Color Bd & Colormagic, 16 color w/Para	\$559	\$395
Color Bd & Draftsman, 16 color w/Para	\$559	\$395
<b>QUADRAM</b> ,		
Quadboard 64K, to 384K, S/P/CC/G	\$395	\$245
Quadboard, no RAM, expand to 384K	\$295	\$225
Quadboard 256K, to 384K, S/P/CC	\$675	\$395
Quadboard, 384K, S/P/CC/G	\$795	\$495
Quadboard II, no RAM, to 256K	\$295	\$215
Quadboard II, 64K, to 256K, 2S/CC	\$395	\$265
Quadboard II, 256K, 2S/CC	\$595	\$395
Quad 512 & 64K, w/serial port	\$325	\$265
Quad 512 & 256K, w/serial port	\$550	\$420
Quad 512 & 512K, w/serial port	\$895	\$625
Quadcolor I, board, 4 colors	\$295	\$195
Upgrade Quadcolor I to II kit	\$275	\$199
Quadcolor, board, Mono, S/P/CC	\$345	\$269
Quadchrome Monitor, 12" RGB Color	\$795	\$495
Quadchrome II Monitor, 14" RGB Color	\$650	\$450
Amberchrome Monitor, 12" Amber	\$250	\$165
Quad 3278	\$1195	\$1050
Quadnet VI	\$2295	\$1545
Quadnet IX	\$1995	\$1745
Quadnet K	\$495	\$385
Quadnet L	\$45	\$29
<b>TG PRODUCTS</b> , Joystick	\$995	\$750
WICAC, Smartboard Keyboard	\$400	\$279

### ★ 256K ★ CHIP KIT \$149

9 Each, 4256 chips  
150 ns

### \$18 ea.

4256 chip, 150 ns

### ★ 64K ★ CHIP KIT \$29

9 Each, 4164 chips  
90 Day Warranty by us



PRICES ARE DROPPING. SO CALL!

### ★ ComX ★ NEW! EconoRAM Plus™ \$395

**384K Multifunction RAM Board expandable to 1.5 Megabyte**  
Works like AST SoPak Plus™ with capacity for up to 1.5 meg. game port, Fastrak™ RAM Disk and Spooler Software.

### EconoRAM™ 384K Single Function Board \$325

With Fastrak™ and Spooler.  
Fully Compatible. 1 Year Limited Warranty.  
Works on DOS 1.1, 2.0 or 2.1.  
Prices and availability subject to change. Call.

## SOFTWARE FOR YOUR IBM-PC, XT, AT or JR

### BUSINESS

	LIST PRICE	CONROY PRICE
<b>APPLIED SOFTWARE</b> , VersaForm	\$389	\$249
<b>ASHTON-TATE</b> , Framework	\$695	\$465
dBase III	\$695	\$360
dBase II, (req. PC-DOS & 128K)	\$495	\$289
dBase II to III upgrade	\$200	\$119
<b>ATI</b> , Training Programs—Large Inventory	\$75	\$50
<b>BPI</b> , Job Cost Accounting	\$795	\$495
Genl Acctg, AR, AP or PR, each	\$595	\$375
<b>BRODERBUND</b> , Bank St., Writer (PC or Jr)	\$80	\$50
<b>CDEX</b> , Training Programs—Large Inventory	\$70	\$45
<b>CONTINENTAL</b> , Ultrafile (PC)	\$195	\$125
Tax Advantage (PC or Jr)	\$70	\$45
FCM (Filing, Cataloging, Mailing)(PC)	\$125	\$75
Property Management (PC)	\$495	\$295
<b>DOW JONES</b> , Investment Evaluator	\$139	\$95
Market Manager Plus	\$300	\$169
Market Analyzer	\$350	\$219
Market Microscope	\$249	\$159
Spread Sheet	\$99	\$65
<b>FOX &amp; GELLER</b> , dutil (DOS or CPM/86)	\$295	\$165
Quacode or dGraph, each	\$495	\$315
<b>HAYDEN</b> , Total Project Manager	\$395	\$239
Harvard Project Manager	\$350	\$219
<b>HAYDEN</b> , Pie Writer	\$50	\$30
Pe Speller	\$295	\$195
<b>HOWARD-SOFT</b> , Tax Preparer for 84	\$250	\$170
Real Estate Analyzer	\$250	\$170
<b>HUMAN EDGE</b> , Mind Prober (PC or Jr)	\$50	\$32
Communications Edge (PC)	\$195	\$119
Sales Edge	\$250	\$159
Management Edge	\$250	\$159
Negotiation Edge	\$295	\$195
<b>IUS</b> , EasyWriter II System	\$350	\$250
EasySpeller II	\$85	\$125
GL, AR, AP, OE or INV, each	\$595	\$375
<b>KENSINGTON</b> , Easy Link Mail Manager	\$95	\$59
<b>LIFETRE</b> , Volkswriter Deluxe	\$395	\$159
Volkswriter	\$195	\$105

### BUSINESS

	LIST PRICE	CONROY PRICE
<b>LIVING VIDEOTEK</b> , Think Tank	\$195	\$105
<b>LOTUS</b> , 1-2-3	\$695	\$465
Symphony	\$695	\$465
<b>MOBS</b> , KnowledgeMan	\$500	\$300
<b>MECA</b> , Managing Your Money	\$195	\$125
<b>MICROPRO</b> , WordStar™ (PC)	\$350	\$189
WordStar™ (Jr)	\$195	\$115
WordStar 2000	\$495	\$295
WordStar 2000 Plus	\$595	\$345
WordStar Professional Plus	\$695	\$395
WordStar Professional, 4 Pak	\$495	\$265
MailMerge, SpellStar or StarIndex, ea.	\$99	\$54
ProOptions Pak (MM/SS/IS)	\$195	\$105
InfoStar Plus (+ Starburst)	\$595	\$315
ConnectStar	\$145	\$77
<b>MICROIM</b> , RBase Series 4000	\$495	\$289
MultiPlan (PC or Jr)	\$150	\$99
RBase Clout	\$195	\$125
<b>MICROSOFT</b> , Spell	\$50	\$32
Multiplan (PC or Jr)	\$195	\$125
Chart or Project, each	\$250	\$155
Word	\$375	\$239
Word with Mouse	\$475	\$289
<b>MONDRAM</b> , Dollars & Sense w/Forecast	\$495	\$295
<b>MULTIMATE</b> , Multitrate Ver. 4.0	\$495	\$295
<b>OPEN SYS</b> , GL, AR, AP, PR, INV or PO, ea.	\$695	\$420
<b>PEACHTREE</b> , Back to Basics GL	\$295	\$175
Peach Pak	\$395	\$225
Peach Text 5000	\$395	\$225
<b>QUADRAM</b> , Tax Strategy	\$395	\$295
Investment Strategy	\$395	\$295
<b>QUE</b> , Using 1-2-3	\$15	\$12
1-2-3 for Business	\$15	\$12
Using Symphony	\$20	\$15
<b>SAMM</b> , Word Plus	\$295	\$185
<b>SATELLITE</b> , WordPerfect (PC)	\$495	\$235
WordPerfect (Jr)	\$69	\$49
<b>SOFTW ARTS</b> , TK Solver(spec DOS)	\$399	\$269
<b>SOFTWARE INTL.</b> , Open Access	\$695	\$395

### BUSINESS

	LIST PRICE	CONROY PRICE
<b>SOFTWARE PUBL.</b> , PFS:Report	\$125	\$79
<b>PFS:File</b>	\$140	\$89
<b>PFS:Write</b>	\$140	\$89
<b>PFS:Graph</b>	\$140	\$89
<b>PFS:Plan</b>	\$140	\$89
PFS:Proof or PFS:Access, each	\$95	\$59
<b>SORCIM</b> , SuperCalc III	\$395	\$245
<b>STONEWARE</b> , Advanced DB Master	\$995	\$395
<b>THORIM</b> , Perfect Writer (PC)	\$345	\$219
Perfect Combo (Writer & Speller) (PC)	\$399	\$199
Perfect Combo (Jr) (Write/Spell/Thesaur)	\$139	\$89
<b>VISICORP</b> , VisiCalc 4	\$250	\$159
<b>WARNER</b> , Desk Organizer (PC or Jr)	\$195	\$125

### UTILITIES

	LIST PRICE	CONROY PRICE
<b>BORLAND</b> , Sidekick (PC or Jr)	\$55	\$35
<b>COMX</b> , Fastrak™, RAM/Disk emulator & printer spooler	\$40	\$30
Sidekick (Coppable) (PC or Jr)	\$85	\$55
Turbo Pascal (PC or Jr)	\$55	\$35
Toolbox (PC)	\$55	\$35
<b>CENTRAL POINT</b> Copy II PC	\$40	\$30
any PC/DOS or RAM Card Menu Drive	\$100	\$59
<b>DIGITAL RES.</b> , CP/M-86™ (P/X/T)	\$80	\$39
CBASIC 86™ (CP/M-86)	\$200	\$135
CBASIC Compiler(CP/M-86 or PC/DOS, ea)	\$600	\$395
Concurrent CP/M-86™ w/windows	\$835	\$225
PL/I (PC DOS)	\$750	\$495
Spooling Prog. (CP/M-86)	\$200	\$135
DR LOGO-86 (CP/M-86)	\$100	\$65
<b>EYKX</b> , In Stock	\$60	\$40
<b>FUNK SOFTWARE</b> , Sideswys	\$60	\$40
<b>HAYES</b> , Smartcom II (Data Comm)	\$149	\$99
<b>LIFEOBAT</b> , Lattice C	\$500	\$295
<b>MICROSTUF</b> , Crosstalk XVI (PC or Jr)	\$195	\$129
<b>MICROSOFT</b> , Macro Assembler	\$100	\$69
Business BASIC Compiler	\$395	\$259
C Compiler	\$800	\$300
COBOL Compiler	\$700	\$459
FORTRAN Compiler	\$350	\$229
PASCAL Compiler	\$300	\$199

### UTILITIES

	LIST PRICE	CONROY PRICE
<b>MOUSE SYSTEMS</b> , PC Paint	\$99	\$69
<b>MORTON</b> , Utilities (14 prgs) New Version	\$100	\$65
<b>OPEN SYSTEMS</b> , BASIC Interpreter	\$195	\$130
<b>ROSESOFT</b> , Prokey	\$130	\$79
<b>WESTERN UNION</b> , Easy Link Mail Mng	\$95	\$65

### HOME & EDUCATIONAL

	LIST PRICE	CONROY PRICE
<b>ARMONK</b> , Executive Suite	\$40	\$27
<b>BPI</b> , Personal Accounting	\$99	\$63
<b>CONTINENTAL</b> , Home Accountant (Jr)	\$75	\$59
Home Accountant Plus (PC)	\$150	\$90
<b>DOW JONES</b> , Home Budget	\$139	\$92
<b>KOALA</b> , Graphics Editor (Jr)	\$40	\$25
<b>MONOGRAM</b> , Dollars & Sense w/forecast	\$165	\$110
<b>SCARBOROUGH</b> , MasterType (PC or Jr)	\$50	\$32
Your Personal Net Worth	\$100	\$63
<b>SIMON &amp; SCHUSTER</b> , Typing Tutor!!!	\$50	\$33

PLUS: BPI, CBS, COMPREHENSIVE, DAVIDSON, HARDCOURT PBL CORP.

### RECREATIONAL

	LIST PRICE	CONROY PRICE
<b>BLUECHIP</b> , Millionaire, Barron, Tycoon, ea	\$60	\$39
<b>BRODERBUND</b> , Large Inventory in Stock		<b>CALL</b>
<b>ELECTRONIC ARTS</b> , Large Inventory in Stock		<b>CALL</b>
<b>HAYDEN</b> , Sargon III (Chess)	\$50	\$34
<b>HWCCOM</b> , Large Inventory in Stock		<b>CALL</b>
<b>MICROSOFT</b> , Flight Simulator (PC or Jr)	\$50	\$33
<b>ORIGIN</b> , Ultima III (PC or Jr)	\$60	\$39
<b>PROFESSIONAL</b> , Trivia Fever (PC or Jr)	\$40	\$25
<b>SPECTRUM HOLOBYTE</b> , Gato	\$40	\$25
<b>SPINNAKER</b> , President's Choice, Amazon, Firehatch, Rendezvous, Dragon, each	\$40	\$25
<b>SUB LOGIC</b> , Night Mission Pirball	\$40	\$27

### CASH-n-CARRY COMPUTER STORES, INC.

Retail Sales only. Call stores for local hours.



**SAN FRANCISCO** — 550 Washington Street (at Montgomery, opposite the Pyramid), Interstate 80, to Highway 480; take Washington Street Exit. CALL (415) 982-6212.

**PORTLAND, OREGON** — At Park 217, Tigard at intersection of Highways 217 and 99W. CALL (503) 620-5595.

**SEATTLE, WASH.** — 3540 128th Ave. SE, Bellevue 98006. In Lohmeyer's Plaza near Factoria Square, SE of Highway 405 & 90 and at SE 36th and Richards. CALL 641-4736.

### OUR REFERENCES:

We have been in computers and electronics since 1958, a computer dealer since 1978 and in computer mail order since 1980. We belong to the Chamber of Commerce (503) 228-9411, and Direct Marketing Association, or call Dunn and Bradstreet if you are a subscriber. Recipient of 1984 Oregon Business Magazine Award.

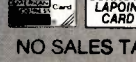
**NO SALES TAX**

**CALL (800) 547-1289**

In Oregon: (800) 451-5151  
TELEX: 910 380 3980

Foreign & Portland Residents Call (503) 620-9877

**QUESTIONS** in your order (503) 620-9878 WEEKDAYS ONLY

**ORDER DESK HOURS** Mon-Fri — 8AM to 6PM PST  
Saturday — 10AM to 4PM PST  
(6AM here is 9AM in New York)



# THIS IS COMPUTER PROTECTION.



To safeguard your computer against mysterious errors and costly servicing, not just any surge and noise suppressor will do. *Serious computer problems demand serious computer protection...* DATAGARD® by SL WABER.

For more information about DATAGARD and our complete line of Computer Accessories, call or write today.



**WABER**

Inquiry 347

A Division of SL Industries, Inc.

Computer Accessories Group  
300 Harvard Avenue  
Westville, NJ 08093  
Toll-free (800) 257-8384  
In NJ (609) 456-5400

*Nobody does it better. Nobody can.*



# THE LISP TUTOR

BY JOHN R. ANDERSON AND BRIAN J. REISER

*It approaches the effectiveness  
of a human tutor*

FOR THE LAST FIVE YEARS, we have been studying how students learn mathematical, logical, and programming skills. We have reached the point where we can develop computer-based tutors for such domains. This article discusses our work on a LISP tutor. LISP is one of the main programming languages of artificial intelligence (AI) and has gained importance with the rising prominence of AI.

Universities like ours, Carnegie-Mellon University (CMU), are seeing a rapidly increasing demand for courses in LISP. Many students here learn it as their first programming language. But LISP is quite difficult because of its symbolic nature and its use of recursion and because of the need to learn abstract AI programming techniques. We see a remarkable range of mastery from courses designed to teach LISP. Some students find that a single course serves as their entry into the world of AI; others leave feeling they have learned nothing.

Studies of students learning such cognitive skills have revealed that private tutoring appears to be much more effective than conventional

classroom instruction. Classroom learning involves listening to lectures, reading texts, and working alone on homework problems. Private tutoring provides the student with an experienced person to guide his reading and problem solving. In a comparison involving LISP, we found that students with private human tutors needed only 11 hours to learn as much as classroom students learned in 43 hours. In both situations most of the time was spent actually trying to write LISP programs rather than reading or reviewing the instruction. The major role of the tutor is to make the problem-solving episodes more effective learning experiences.

Educational psychologists have observed that private tutoring is an advantage with many different types of material. One study (see reference 1) compared students who spent the same amount of time learning—some with private tutors and some in the classroom—for two different subjects, probability and cartography. Ninety-eight percent of the tutored students did better on performance tests than the average classroom student did. Interestingly, the major benefit occurred with the poorer students. There was

relatively little advantage of private tutoring for the best students.

Our goal has been to develop a computer-based tutor that is as effective in teaching LISP as a human tutor. GREATERP (Goal-Restricted Environment for Tutoring and Educational Research on Programming) is an attempt to combine artificial-intelligence technology and a psychological theory of skill acquisition into an effective teaching device. This tutor is itself a large LISP program that runs under Franz LISP on VAXes. We have already begun field testing this tutor in CMU classrooms and have seen it lead college students to faster, more effective learning of LISP programming. In this article, we discuss how the tutor works, why it is effective, and the prospects for moving a version of it to personal computers.

GREATERP is only one of the tutors

*(continued)*

John R. Anderson is a professor of psychology and computer science at Carnegie-Mellon University. He has a Ph.D. from Stanford University. Brian J. Reiser holds a Ph.D. from Yale University and is doing postdoctoral research at CMU. Write to them at Carnegie-Mellon University, Department of Psychology, Schenley Park, Pittsburgh, PA 15213.



that we have developed at Carnegie-Mellon. The Advanced Computer Tutoring Project at CMU currently has tutors under development for high-school algebra and geometry, and we have plans to create tutors for calculus and other programming languages such as Pascal and Prolog. The LISP tutor provides an example of our approach in bringing AI techniques into educational-software development.

### INTELLIGENT TUTORING

These tutoring projects are examples of a particularly promising approach to educational software called *intelligent tutoring* (see reference 2). Such systems differ from other AI approaches to education by their attempt to provide effective instruction in problem solving the way a human tutor does.

There are a number of components typically found in an intelligent tutoring system. First, there is a *domain expert*, which can actually solve the problems. (GREATERP contains a system that can write LISP functions from problem specifications.) Second, there is a *bug catalog*, which contains all the possible deviations a particular student can make from the ideal expert behavior. Third, there is a *tutoring module*, which constitutes an expert system for instruction. It is based on three sets of principles: one for determining from a student's behavior what he knows and what confusions or *bugs* he has, another for deciding when to interrupt him in the problem-solving process and what to say, and a third to figure out what problems a student should do and when he should advance to new material. Typically, these decisions are based on an internal model that the tutor keeps of the student's knowledge and difficulties so far, enabling it to tailor its instruction to each individual student.

Finally, the tutoring system must contain an interface for communicating with the student. Its construction requires human-engineering decisions concerning how to present information understandably, how to query the

student, how the student should enter answers, and what information should be maintained on the screen.

Until recently, intelligent tutoring was a topic for advanced research but didn't seem to offer a viable method for delivering educational software. This situation has changed for two reasons. First, an increasing expertise in cognitive psychology and artificial intelligence allows us to build such tutors much more efficiently and rapidly. For example, we can develop lesson material on our LISP tutor at a faster rate than that estimated for conventional educational software (200 hours per hour of instruction). Second, while an intelligent tutor requires a larger, faster computer, hardware costs are dropping to where it is becoming cost-effective to purchase the equipment required.

### DESIGN OF THE LISP TUTOR

The goal underlying our design of the LISP tutor is simple: A student should be able to work on a problem in a "friendly" environment, as if he were using a smart, structured editor. However, whenever he makes a planning or coding error or asks for help, the tutor should provide helpful information that guides the student back to a correct path to the solution. In addition, we wanted our tutoring environment to represent the conceptual structure of programming problems better than a simple screen editor.

In order to monitor a student's progress and discover and instruct about errors, the tutor must be able to solve the problems the student is working on. Therefore, the first component in the LISP tutor is the *ideal model*, a simulation of the programming knowledge ideal students use in solving problems. This ideal model is based on a detailed theory of how students learn to program (see reference 3).

We used GRAPES (Goal-Restricted Production System, see reference 4) to represent the rules programmers have for solving problems. Each problem-solving rule is represented in the system as a production rule. Each pro-

duction rule contains an IF part, which is a set of conditions used to determine if the rule applies, and a THEN part, which specifies what to do in that situation. The following are English versions of two of the hundreds of GRAPES production rules known by the tutor:

```
IF    the goal is to combine LIST1
      and LIST2 into a single list
THEN use the function APPEND and
      set as subgoals to code LIST1
      and LIST2

IF    the goal is to check that a
      recursive call to a function will
      terminate and the recursive
      call is in the context of a MAP
      function
THEN set as a subgoal to establish
      that the list provided to the
      MAP function will always
      become NIL after some
      number of recursive calls
```

The first is a straightforward production rule about the use of the LISP function APPEND to make one list from two other lists. The second is a rather esoteric production rule that an advanced programmer might have. When the ideal model codes a LISP function, it applies many production rules like these to plan and then write the code. It also contains a large set of *buggy* rules that represent misconceptions novice programmers often develop during learning.

The ideal model represents the knowledge we want the student to acquire. But the tutor must also represent what he currently knows or does not know and his approach to each particular problem. The tutor follows the student as he types in his code, symbol by symbol, and tries to figure out what correct or buggy production rule would have led to that input. If the rule found is a correct one, then the tutor stays silent and waits for further input. If, on the other hand, the input is in error, the tutor interrupts with advice. Thus, as long as the student follows a path leading to a correct solution, the tutor stays in the background.

(continued)



# Put your blue box out to pasture.

## Genesis Has Better Choices for Superior 8086 Designs.

Genesis development tools turn your IBM PC or compatible computer into the most flexible, comprehensive development system made for 8086-family designs. Genesis offers the widest choice of proven languages, superior debugging tools, and even in-circuit emulators. It all starts with ACCESS, the superior Genesis operating environment that allows Intel's 8086 development software to run under MS-DOS. And not only do we sell ACCESS and all the Intel languages for 8086 and 80186 designs — we also offer an ACCESS system for 8-bit designs as well.

## Genesis Is Faster.

You get performance as well as flexibility with Genesis. For example, in our tests the ASM 86 assembler running under ACCESS on an IBM PC AT runs 4.7 times as fast as the assembler on a hard-disk based Series III and an incredible eleven times faster than a

floppy-disk based Intel system. The ASM 86 assembler we tested under ACCESS even ran 1.53 times faster than a VAX 11/782 running competing cross-software.

## Genesis Is Easier to Use.

Of course, Genesis offers more than speed of execution. The GeneScope family of symbolic debuggers and in-circuit emulators share the most powerful and easiest to use human interface available today. GeneScope offers high-level macro facilities, an on-line symbolic assembler, alphanumeric and graphic support, and many more features that make Genesis tools a better solution than other systems.

## Genesis Costs Less.

With Genesis you get all the flexibility of a personal computer and all the power of expensive dedicated development systems. You can get your products to market faster, at a fraction of the cost.

Is there really any reason to keep using obsolete, expensive equipment — when you can have Genesis instead? **Quit chewing your cud** — give us a call and find out how Genesis tools can make your life easier.



Genesis Has a Better Solution.



**Genesis™**  
Microsystems

Genesis Microsystems Corporation  
196 Castro Street  
Mountain View, California 94041  
Phone: (415) 964-9001  
Telex: 4998093 GENMS UI

Inquiry 165





## *The LISP tutor works through the algorithm step by step.*

The LISP tutor is designed to provide as much guidance as necessary. When it finds that the student is having difficulty coding a problem, it takes him from "coding mode" into "planning mode"; that is, the tutor works through the algorithm with the student, step by step, using an example. After the algorithm is constructed, the student can return to coding, presumably with a better idea of what he should do to get his code to work properly.

We have designed this tutor with a strong commitment to immediate feedback. As soon as the student makes a mistake, the tutor responds with an appropriate diagnostic message. Because a student can write his code a small piece at a time, the feedback appears as soon as one item is wrong. By contrast, in the standard learning situation a student only receives feedback after he codes the entire function—or set of functions—and tries to run it. There is considerable psychological evidence that humans learn better with immediate feedback.

The tutor also provides guidance by hinting toward the correct solution if the student is having difficulty. These hints take the form of queries and reminders about current goals. If necessary, the tutor can provide the next small piece of code so that the student can continue. This is done at the student's request or after he has made more than the maximum number of allowed errors—usually two—for that portion of code. The goal here is for the student to do as much of the work as possible. Students learn much more effectively by doing than by watching. By providing the next portion of code, the tutor enables the student to work through the rest of the problem in cases where he might otherwise have given up. As

a consequence, he can tackle more and more difficult problems.

A major design feature of the tutoring interface provides the student with a structured editor through which to enter code. This editor automatically balances parentheses and provides placeholders for the arguments of each function. For example, to write a function definition in LISP, you must use the function `defun` followed by the function name, a parameter list, and the function body. To begin, the student types a left parenthesis and the word `defun`. As soon as he types the space following that word, the tutor redisplay the code as

```
(defun <NAME> <PARAMETERS>
  <PROCESS>
)
```

The symbols in angle brackets indicate arguments that must be coded. The tutor places the cursor underneath `<NAME>` and highlights it to indicate that the function name must be coded next.

This structured editor relieves students of the burden of balancing parentheses and checking syntax. It enables them to focus on the more conceptually difficult aspects of LISP. Our results show that this leads to faster learning of these major techniques and skills—with no deficit in syntax knowledge. Students removed from the tutor perform as well as or better on all aspects of coding, including algorithm design, memory for LISP functions, and syntax, than those conventionally taught.

The editor also facilitates communication between the student and the tutor. Our studies of interfaces have shown that in the normal question-and-answer format of most educational software, the tutor and the student can easily get "out of sync" on complex problems, where the student is not sure what part of the problem the tutor is talking about. In the LISP tutor, the student types directly into the code, replacing one of the placeholders, and thus it is always clear what part of the problem is being coded. Furthermore, these symbols help to communicate the conceptual structure of the programming prob-

lem. For example, when the student types the iterative construct `prog`, the tutor provides the template for iteration:

```
(prog <LOCAL VARIABLES>
  <INITIALIZATIONS>
  <BODY>
  <REPEAT>
)
```

This template helps to structure the problem into a list of local variables, initializations of those variables, code for the program body (i.e., the repeated actions), and a return to the start of the loop. In many cases a symbol is expanded into more detailed symbols; for example, the `<BODY>` is coded as two portions: a `<TERMINATING CASE>` and the `<UPDATING CODE>`.

When an error arises or the student requests assistance, the tutor constructs an English explanation based on templates associated with each production rule. These explanation templates allow the tutor to describe an error or provide a hint by using a general rule *and* making reference to the specific problem being coded. However, writing programs to *understand* natural language is an enormously difficult and expensive task. In fact, students' descriptions of their algorithms are often hard for even human tutors to understand. Therefore, when the student is working with the tutor to design an algorithm, rather than having him type in English responses to the tutor's questions, we provide a menu of choices for his responses. This menu is constructed from the English descriptions of the correct and buggy production rules under consideration.

### **LEARNING LISP WITH THE TUTOR**

Currently the LISP tutor contains approximately 325 production rules about planning and writing LISP programs and 475 buggy versions of those rules. It is effective in diagnosing and responding to between 45 and 80 percent of the student's errors, depending on the complexity of the

(continued)



# Move over, Crosstalk™ . . .



The NightOwl's in town  
and he's packing a  
16-bit MEX!

Last year, the NightOwl delivered MEX, the Modem EXecutive that tamed the 8-bit communications frontier.

This year, he's doubled his byte with MEX-PC — the supercharged 16-bit communications package for the IBM-PC — and he's looking to take on the big boys, feature for feature.

**\$59.95** plus \$5 for shipping and handling  
(includes MEX-PC software and complete manual)

Supports all popular modems • Programmable for unattended operation • Extensive HELP overlay • Auto-dial and redial • Alternate long distance dialing (ALD) • "List" dialing with automatic baud switching • Instant defining of IBM-PC function keys • Fast creation of custom "smart" phone directories • All popular protocols — extended Christensen XMODEM (Checksum and CRC) CompuServe A, ASCII (X-on, X-off) odd-even-none bit parity • A CLONE routine for unlimited creation of customized versions • Full access to your own operating system and software while logged onto a host system • Delay-adjustable Break key • DOS-compatible commands • Supports all monitors, port switching, named directories, on-line printing • IBM-PC-XT-AT — all DOS levels • 110 to 19,200 baud on most equipment • Source code for any overlay available

*"Individually, each of these features enhances the experience of telecomputing, but together they add up to enormous power and flexibility . . . one of the most innovative and sophisticated communications packages available . . . MEX has been greeted with universal acclaim."*

That's how Link-Up magazine described the 8080 version of MEX last September. Now, there's MEX-PC!

You've struggled with overpriced, so-called smart terminal software long enough.

Now, experience the genius, the economy, the power! of MEX-PC.



Give us a call at 1-800-NITEOWL

(in Wisconsin, call 414-563-4013)

Crosstalk XVI is a trademark of Microstuf, Inc., Atlanta, GA  
MEX-PC is a trademark of NightOwl Software, Inc., Rt. 1, Box 7, Fort Atkinson, WI 53538





Table 1: *The LISP curriculum.*

1. Basic LISP functions
2. Defining new function
3. Conditionals and predicates
4. Structured programming
5. Progs, input/output, and evaluation
6. Integer-based iteration
7. Integer-based recursion
8. List-based recursion
9. List-based iteration
10. Advanced recursion
11. Advanced programming constructs: Maps, Dos, Lets
12. Property lists and arrays
13. Search techniques
14. An advanced problem: Waterjug
15. List structure and destructive functions
16. Macros and advanced function types
17. Advanced topic: Pattern Matching
18. Advanced topic: Implementing Production Systems

Listing 1: *The dialogue between student and computer tutor to define the function rightp.*

Define `rightp`. It takes 3 arguments, `side1`, `side2`, and `side3`, which represent the lengths of the three sides of a given triangle, where `side3` is the longest side. `rightp` tests whether the three sides form a right triangle. In a right triangle, the sum of the squares of `side1` and `side2` is equal to the square of `side3`. However, your function should allow for a measurement error of 2 percent. In other words, your function should return `t` if the sum of the squares of the first two sides is within 2 percent of the square of the third side.

For example (`rightp 3 4 5.01`) = `t`, because 3 squared + 4 squared = 25, which is within 2 percent of 5.01 squared.

1. (`defun rightp (side1 side2 side3) (cond)`)

Yes, you could use `cond` here, but there is a much easier way to test if the sum of the squares of the first two sides is within 2 percent of the square of the third. You can use a predicate, since we only have one test to do.

2. (`defun rightp (side1 side2 side3)`

```
(lessp (difference) <NUM2 >))
```

You want to code the amount of difference between the sum of the squares of the first two sides and the square of the third side, and you do *not* care which of those two numbers is larger. So we want to take the absolute value of their difference.

3. (`defun rightp (side1 side2 side3)`  
`(lessp (abs (difference <NUM3 > <NUM4 >))`  
`<NUM2 >))`

Which do you want to do first?

PRESS: IF YOU WANT TO:

- 1 Write code to get the sum of the squares of the first two sides.
- 2 Write code to get the square of the third side.

Menu choice: 1

4. (`defun rightp (side1 side2 side3)`  
`(lessp (abs (difference (plus) <NUM4 >))`  
`<NUM2 >))`

(continued)

## *Each lesson takes from one to four hours to complete.*

lesson and the amount of testing we have conducted. The curriculum we have designed is shown in table 1. The system successfully tutors students through problems on lessons 1 to 10, each lesson taking from one to four hours to complete. Each topic involves a small instructional booklet and many problems practicing the skills taught in that lesson. Our goal in designing these booklets was to keep the written instruction to a minimum. There is considerable evidence that written technical instruction is most effective when it is brief (see reference 5).

Most of the time in any lesson is spent going through problems. Listings 1 and 2 illustrate sample dialogues in which the tutor monitors the student's progress through simple problems. This does not present the tutor as it really appears. Instead, it shows essentially *teletypewriter* versions of the student-tutor dialogue. The actual interaction involves the use of several display windows: a *code window* in which the student types the code, a *tutoring window* in which tutoring feedback is displayed, and a *goals window* in which reminders are presented.

In the teletypewriter versions the tutor's output is given in normal type characters, while the student's input is shown in bold characters. These listings present "snapshots" of the interaction; each time the student provokes a response, we have listed his input along with the tutor's response (numbered for convenience). The total code as it appears on the screen is shown, although the student has added only what is different from the previous code (shown in boldface type). For example, in line 2 of listing 1 he has typed (`lessp (difference` as an extension of the code in line 1.

It is important to note several things

(continued)



# MICRO CAP and MICRO LOGIC put your engineers on line... not in line.



## MY OWN WORKSTATION



How many long unproductive hours have you spent "in line" for your simulation? Well, no more. MICROCAP and MICROLOGIC can put you on line by turning your PC into a productive and cost-effective engineering workstation.

Both of these sophisticated engineering tools provide you with quick and efficient solutions to your simulation problems. And here's how.

## MICROCAP: Your Analog Solution

MICROCAP is an interactive analog circuit drawing and simulation system. It allows you to sketch a circuit diagram right on the CRT screen, then run an AC, DC, or Transient analysis. While providing you with libraries for defined models of bipolar and MOS devices, Opamps, transformers, diodes, and much more, MICROCAP also includes features not even found in SPICE.

MICROCAP II lets you be even more productive. As an advanced version, it employs sparse matrix techniques for faster simulation speed and larger net-

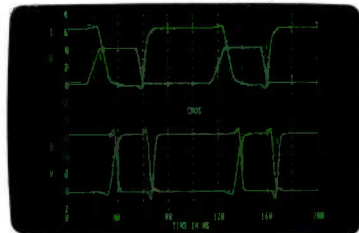

"Typical MICROCAP Transient Analysis"

works. In addition, you get even more advanced device models, worst case capabilities, temperature stepping, Fourier analysis, and macro capability.

## MICROLOGIC: Your Digital Solution

MICROLOGIC provides you with a similar interactive drawing and analysis environment for digital work. Using standard PC hardware, you can create logic diagrams of up to 9 pages with each containing up to 200 gates. The system automatically creates the netlist required for a timing simulation and will handle networks of up to 1800 gates. It provides you with libraries for 36 user-defined basic gate types, 36 data channels of 256 bits each, 10 user-defined clock waveforms, and up to 50 macros in each network. MICROLOGIC produces high-resolution timing diagrams showing selected waveforms and associated delays, glitches, and spikes—just like the real thing.

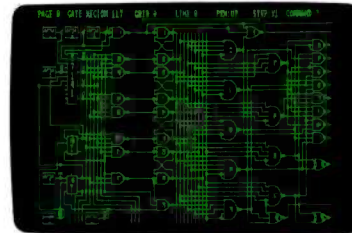

"Typical MICROLOGIC Diagram"

## Reviewers Love These Solutions

Regarding MICROCAP . . . "A highly recommended analog design program" (PC Tech Journal 3/84). "A valuable tool for circuit designers" (Personal Software Magazine 11/83).

Regarding MICROLOGIC . . . "An efficient design system that does what it is supposed to do at a reasonable price" (Byte 4/84).

MICROCAP and MICROLOGIC are available for the Apple II (64k), IBM PC (128k), and HP-150 computers and priced at \$475 and \$450 respectively. Demo versions are available for \$75.

MICROCAP II is available for the Macintosh, IBM PC (256k), and HP-150 systems and is priced at \$895. Demo versions are available for \$100.

Demo prices are credited to the purchase price of the actual system.

Now, to get on line, call or write today!

## Spectrum Software

1021 S. Wolfe Road, Dept. B  
Sunnyvale, CA 94087  
(408) 738-4387

Inquiry 361



# EXPOTEK

1-800-528-8690

ORDER LINE

## Guaranteed Low Prices

All prices are for cash, cashiers check or money order. Allow 4 weeks bank clearance for personal checks. C.O.D.'s, Visa, MC, and P.O.'s accepted at additional charge. Prices subject to change. Returns must have authorization number and are subject to a restocking charge.

### COMPUTERS & TERMINALS

<b>ADDS</b>	<b>QUME</b>
<b>ALTOS</b>	<b>SANYO</b>
<b>APPLE</b>	<b>TELEVIDEO</b>
<b>ESPIRIT</b>	<b>VISUAL</b>
<b>NEC</b>	<b>WYSE</b>
<b>NORTHSTAR</b>	<b>ZENITH</b>

### SWITCH BOXES

2 POS RS232 .....	\$75
4 POS RS232 .....	115
2 POS Centronics .....	93
4 POS Centronics .....	121

### MODEMS

Novation-J-Cat .....	99
Smart Cat .....	399
Hayes Smart Modem 300/1200 .....	219/479
1200B .....	429
Anchor Signalman .....	Call
Qubie Internal/RS232 .....	269/285

### ACCESSORIES

AST latest boards .....	Call
Chips & Microprocessors .....	Call
GSF Surge Protector .....	59
Kraft Joysticks (IBM or Apple) .....	29
Printer Buffers & Spoolers .....	Call
Quadram all products .....	Call
Ribbons (doz.) & Printwheels .....	Call
Standby Power Systems .....	Best Price
Tractors & Sheetfeeders .....	Call

### CAD

HOUSTON INST. PLOTTER	<b>SAVE CALL</b>
KURTA DIGITIZER	
CORVUS NETWORK	

### DISK DRIVES

Alpha Omega 10MB w/controller (IBM) .....	799
TEAC 55B slimline DSDD .....	149
Bernoulli Box .....	1949
Tandon 100-2 .....	199
Maynard 10MB-WS-2 with EPROM .....	1149
Tallgrass Tech Hard Disk System .....	Call
Microsci A2 (Apple) .....	189
CORVUS .....	Call

### MONITORS

Amdek .....	Call
Leading Edge Color RGB .....	379
PGS-HX-12 .....	489
PGS MAX-12 Amber .....	179
Zenith 122/123 .....	89

### PRINTERS

<b>C. Itoh</b>	<b>Juki</b>
1550 AP ..... 449	6100 ..... 379
1550 BCD ..... 485	<b>Okidata</b>
8510 AP ..... 299	All Models ..... Call
7500 ..... 215	<b>Panasonic</b>
A10-30 ..... 475	All Models ..... Call
F10-40 ..... 879	<b>Qume</b>
F10-55 ..... 1049	Letter Pro ..... 629
<b>Daisywriter</b>	11/40 WIBM IF.. 1369
2000 ..... 985	11/55 WIBM IF.. 1569
<b>Diablo</b>	<b>Star Microtronics</b>
620 API ..... 739	New Models ..... Call
630 API ..... 1669	<b>Tally</b>
630 ECS ..... 1999	160L w/Tractor... Call
<b>Epson</b>	<b>Toshiba</b>
All ..... Call	1340/1351 ..... Call
<b>NEC • NEC • NEC • NEC • NEC • NEC</b>	
P2 ..... 515	3550 ..... 1489
P3 ..... 739	7710 ..... 1639
2050 ..... 779	8850 ..... 1799
P2/P3 Parallel Int. Face .....	139

2017 E. Cactus, Phoenix, AZ 85022  
(602) 482-0400

## LISP TUTOR

No. You should create a helping function for this code, rather than coding it directly. Our function, `rightp`, is now 4 levels of embedding deep, and the relation we are about to code—the sum of squares of two numbers—would be a useful helping function. Thus, let's code the sum of the squares of the first two sides using a helping function.

```
5. (defun rightp (side1 side2 side3)
    (lessp (abs (difference (sumsq < ARGUMENTS >) < NUM4 >))
           < NUM2 >))
```

What do you want the helping function `sumsq` to do?

PRESS: IF YOU WANT TO:

- 1 Take 2 arguments, the square of the first side and the square of the second side. Compute their sum.
- 2 Take 2 arguments, the first side and the second side. Compute the sum of the squares of these numbers.
- 3 Have the tutor choose.

Menu choice: 1

No. We wouldn't need a helping function `just` to compute the sum of two numbers. You should create your helping function so that it does more than just a sum.

It would be better to define `sumsq` so that it takes two arguments, in this case, [1] the first side, and [2] the second side, and computes the sum of the squares of these numbers.

Menu choice: 2

```
6. (defun rightp (side1 side2 side3)
    (lessp (abs (difference (sumsq side1 side2) (times)))
           < NUM2 >))
```

You should use a helping function that you have already coded, `square`. Since this function computes the square of a number, you can use it to code the square of the third side.

```
7. (defun rightp (side1 side2 side3)
    (lessp (abs (difference (sumsq side1 side2) (square side3))) (plus)))
```

I don't understand that, Rob. How are you going to code 2 percent of the square of the third side?

### [EXPLAIN]

OK. I'll explain what I wanted. You could either code this directly or create a helping function here to code 2 percent of the square of the third side. Let's create a helping function `just` to make things easier. We'll call this helping function `percentage`. We will define `percentage` when we are finished coding `rightp`.

What do you want the helping function `percentage` to do?

PRESS: IF YOU WANT TO:

- 1 Take 2 arguments, one hundredth of 2 and the square of the third side. Compute their product.
- 2 Take 2 arguments, 2 and the third side. Compute the given percentage of the square of its second argument.
- 3 Take 2 arguments, 2 and the square of the third side. Compute the given percentage of its second argument.
- 4 Take 1 argument, the square of the third side. Compute 2 percent of its argument.
- 5 Have the tutor choose.

Menu choice: 3

Very good.

```
8. (defun rightp (side1 side2 side3)
    (lessp (abs (difference (sumsq side1 side2) (square side3)))
           (percentage 2 (square side3))))
```

(continued)



# The Hard Disk With The Software Shell

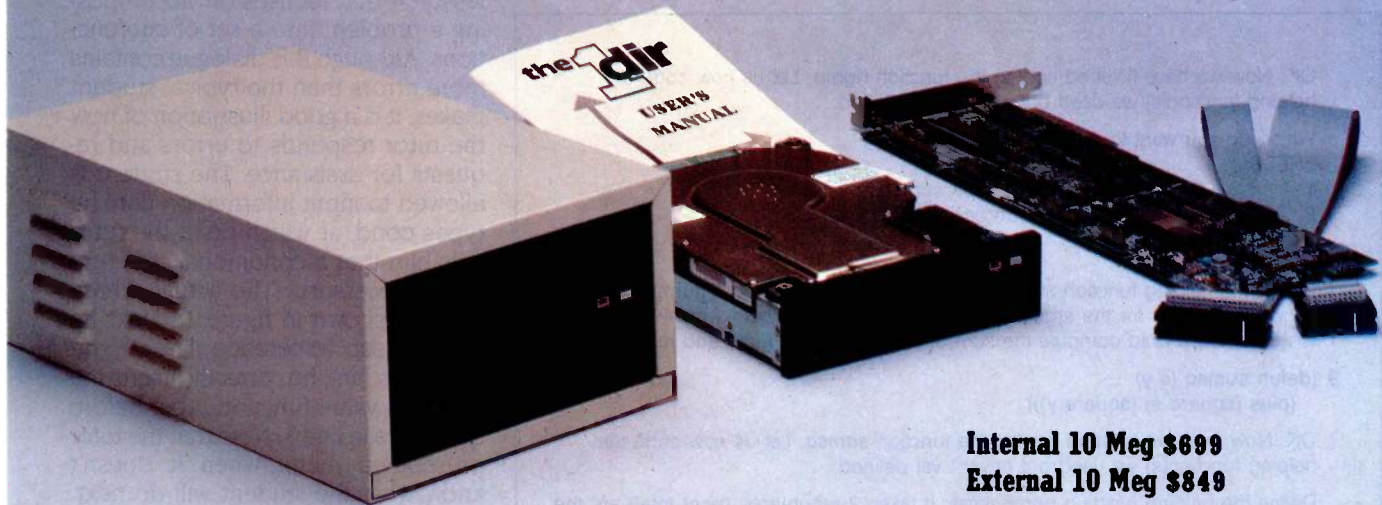

Internal 10 Meg \$699  
External 10 Meg \$849

**Why pay more for 10 or 20 Meg drives than you have to?** Our 10 Meg internal hard disk subsystem is priced at \$699, with the 20 Meg model going for \$1088. Our external 10 Meg goes for \$849, 20 Meg for \$1238.

**Our drives are fully compatible** with any IBM PC or PC-compatible with 64K RAM and PC-DOS 2.0 or later.\* Qubie' drives boot directly from the hard disk. You can power up the PC and load the system directly, without using any floppy disks. No software patches or drivers to install.

**Using the same amount of power** as a floppy drive, the Qubie' hard disk uses less energy than other aftermarket drives.

type in DOS commands, and are all selected by using cursor control keys. 1dir even explains commands with HELP screens that give you on-line advice when you need it.

**Qubie' drives are made of special** plated recording media. They withstand the vibration and movement that has damaged hard disks in the past. In fact, Qubie' drives have been selected by several computer makers for use in their portable computers.

**Good service starts with answering** your questions before and after you buy. It continues with same or next day shipment of your order. Since we only sell a few selected products, we have the information and inventory to help you fast.

**We perform repairs in our own service** department within 48 hours, should you ever need service during the one year warranty period.

**Our price is the whole price.** All prices include UPS surface charges and insurance. In a hurry? Two day UPS air service is just \$12.

**Corporations, dealers and institutions,** call for volume purchase price information.

\*Call for information.

Inquiry 327

## No Risk Guarantee

If you are not completely satisfied with your purchase, you may return it within 30 days for a full refund, including the cost to send it back. If you can get any of our competitors to give you the same guarantee, buy both and return the one you don't like.



**The drives come complete with 1dir software.** 1dir's commands are in English, eliminating the need to

## Order Today, Shipped Tomorrow!

For fastest delivery, send cashiers check, money order, or order by credit card. Personal checks, allow 18 days to clear. California residents, add 6% sales tax. Hours: Mon-Fri. 8:00 a.m.-6:00 p.m. PST Sat. 9:00 a.m.-1:00 p.m. PST

**(800) 821-4479**

Toll Free Outside California

**(805) 987-9741**

Inside California

**QUBIE'**



4809 Calle Alto  
Camarillo, CA 93010

London (01) 223-4569

Paris (01) 321-5316

Sydney (02) 579-3322

© Qubie' 1984



about these dialogues. First, recall that the tutor balances parentheses and provides placeholders (e.g., <CASE>, <NAME>, <NUM>) for portions of code that need ex-

panding. Second, despite the large portions of code added from one line to the next, it understands each separate word or symbol the student enters, and it responds with an error

message if necessary for any of those items.

### THE rightp PROBLEM

Listing 1 presents a dialogue from lesson 4 that focuses on decomposing a problem into a set of subfunctions. Although this dialogue contains more errors than the typical student makes, it is a good illustration of how the tutor responds to errors and requests for assistance. The student is allowed to input information until he types cond, at which point the tutor tells him that a conditional structure is not necessary. (The actual screen setup is shown in figure 1.) Next he types (lessp (difference (line 2) and receives a hint; he correctly inserts the absolute value function (abs) before difference in line 3. Note that the tutor presents a menu when it doesn't know what the student will do next. For instance, since the arguments to difference in rightp can be in either order, it needs to know which one will be typed next, and it asks him via the menu following line 3.

After line 4 the tutor gives the student information about when it is useful to code a separate helping function. It queries him after line 5 to make sure they agree on what that helping function will compute. This is an example of the tutor's planning mode. In this case, the student is mistaken about what the subfunction should do; the tutor corrects him. After line 7 it determines that his code will not achieve the goal. However, this input does not match any of the buggy rules in the ideal model, so the tutor provides minimal feedback: it indicates that it cannot understand the input and queries the student to remind him about what he should be trying to code. This hint is not enough for the student, who asks for an explanation by hitting a special key, whereupon the tutor helps him specify another helping function, percentage.

The final form of rightp is displayed in line 8. In line 9 the student defines the helping function sumsq without error and goes on to define percent-

(continued)

OK. Now we have finished coding the function rightp. Let us now code the helping function(s) we used but haven't yet defined.

Which do you want to do first?

PRESS: IF YOU WANT TO:

- 1 Define the helping function sumsq.
- 2 Define the helping function percentage.

Menu choice: 1

Define the helping function sumsq. It takes 2 arguments. (num1 num2) are the suggested names for the arguments, but you may name them whatever you wish. sumsq should compute the sum of the squares of num1 and num2.

- 9. (defun sumsq (s y)
  - (plus (square s) (square y)))

OK. Now we have finished coding the function sumsq. Let us now code the helping function(s) we used but haven't yet defined.

Define the helping function percentage. It takes 2 arguments. (pcnt total) are the suggested names for these arguments, but you may name them whatever you wish. percentage should compute pcnt percent of total.

- 10. (defun percentage (x y)
  - <PROCESS>

#### [EXPLAIN]

OK. I'll explain what I wanted. Let's figure out how to code x percent of the second number.

How can you code x percent of the second number?

PRESS: IF YOU WANT TO:

- 1 Multiply the second number by one-hundredth of x.
- 2 Multiply the second number by x.
- 3 Divide the second number by 100.
- 4 Have the tutor choose.

Menu choice: 1

Good.

- 11. (defun percentage (x y)
  - (times <NUM1> <NUM2>))

What do you want to do first?

PRESS: IF YOU WANT TO:

- 1 Write code to get one-hundredth of the first number.
- 2 Write code to get the second number.

Menu choice: 1

- 12. (defun percentage (x y)
  - (times (quotient x .01) <NUM2>))

No, that is not the right number. How are you going to specify one hundred in LISP?

- 13. (defun percentage (x y)
  - (times (quotient x 100) y))

OK. Now we have finished coding the function percentage. There are no more helping functions to define.



# Inside Outside

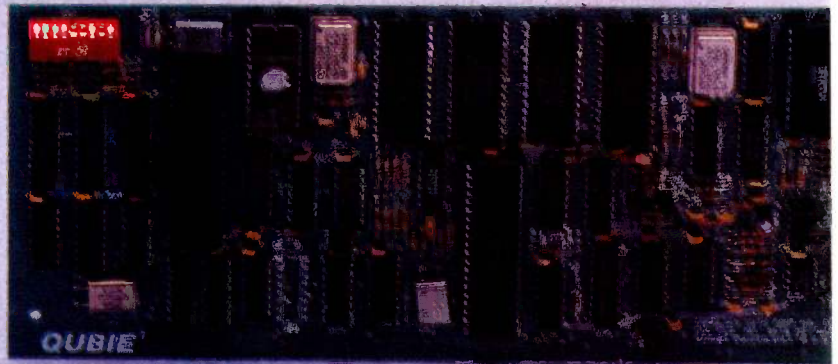
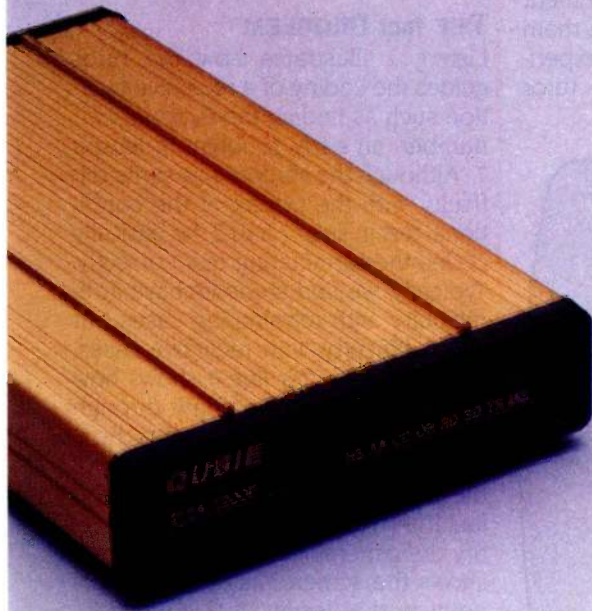

PC212A/1200 \$299  
212A/1200E \$329

**Why pay more for a 300/1200 baud modem than you have to?** Through the use of four low-cost, state-of-the-art microprocessors, we can now offer two versions of our full featured modems at prices, hundreds less than the competition. PC212A/1200 is available for \$299, the 212A/1200E for \$329.

**Our modems are fully compatible** with all Hayes software commands. Software packages like Crosstalk™, Sidekick™ and SmartcomII™ will work with our modems.

**Our internal modem card,** PC212A/1200, is designed specifically for the IBM PC, PC/XT or other PC-compatible units.\* The board occupies only one slot, since it is just 6/10" in thickness. The optional asynchronous port, available for \$40, can be used for other peripherals when the modem is not being used. The modem comes complete with PC-TALK III™, modular phone cable, card edge guide, and user's guide.

**Our external standalone modem,** 212A/1200E, can be used with any computer or terminal that has an RS-232C serial port. The modem is housed in an attractive gold anodized case and fits comfortably under a standard telephone.

An easily accessible volume control knob adjusts the modem speaker's output. The modem comes complete with modular phone cable, serial connector cable, and user's guide.

**Both modems are Bell 103/212A compatible.** Both feature auto-dial and can be accessed remotely through an auto-answer mode.

**Good service starts with answering** your questions before and after you buy. It continues with same or next day shipment of your order. Since we only sell a few selected products, we have the information and inventory to help you fast.

**We perform repairs in our own service** department within 48 hours, should you ever need service during the one year warranty period.

**Our price is the whole price.** All prices include UPS surface charges and insurance. In a hurry? Two day UPS air service is just \$5.

**Corporations, dealers and institutions,** call for volume purchase price information.

Inquiry 328

\*Call for information.

## No Risk Guarantee

If you are not completely satisfied with your purchase, you may return it within 30 days for a full refund, including the cost to send it back. If you can get any of our competitors to give you the same guarantee, buy both and return the one you don't like.

## Order Today, Shipped Tomorrow!

For fastest delivery, send cashiers check, money order, or order by credit card. Personal checks, allow 18 days to clear. California residents, add 6% sales tax. Hours: Mon.-Fri. 8:00 a.m.-6:00 p.m. PST Sat. 9:00 a.m.-1:00 p.m. PST

**(800) 821-4479**

Toll Free Outside California

**(805) 987-9741**

Inside California

**QUBIE'**



4809 Calle Alto  
Camarillo, CA 93010

London (01) 223-4569  
Paris (01) 321-5316  
Sydney (02) 579-3322

© Qubie' 1984



age in line 10. He is stuck as to what to do after typing the function body and requests an explanation. The tutor helps him refine his algorithm. After this he defines percentage with one error in line 12.

After the student defines rightp and its helping functions, the LISP tutor puts him into a real LISP environment where he can experiment with them and try variations. After he experiments to his satisfaction, the tutor

provides the next problem in the lesson.

**THE fact PROBLEM**

Listing 2 illustrates how the tutor guides the coding of a recursive function such as finding the factorial of a number, an early problem in lesson 7. Although the student has some difficulty with the syntax of the conditional test in lines 1 and 2, he basically codes the terminating test correctly. Typically, we find students have little difficulty with terminating cases but great difficulty with recursive cases. The dialogue after line 3 shows how the tutor guides the student through the design of the recursive function. It leads him to construct examples of the relationship between fact (n) and fact (n - 1) and then asks him to identify the general relationship. Figure 2 shows the screen image at a critical point in the design of this function.

The dialogue after this point shows two classic errors students make in defining recursive functions. The first in line 4 is to call the function directly without combining the recursive call with other elements. The second, in line 6, is to call the function recursively with the same argument rather than a simpler one.

After the student finishes coding the function, he goes to the LISP window and experiments with it. He must trace the function and the recursive calls embed and unravel. Figure 3 shows the screen image at this point, with the code on top and the trace below it.

**EVALUATING THE LISP TUTOR**

We should emphasize that the tutorial knowledge in these interactions was not especially handcrafted for these problems; it shows the general approach used by the tutor. That is the power of an intelligent tutoring system. Once we have a system that can tutor recursion problems, for example, we can easily add problems on that topic. Furthermore, although some testing is necessary to build our catalog of student errors and misconceptions, once coded, the tutor can

(continued)

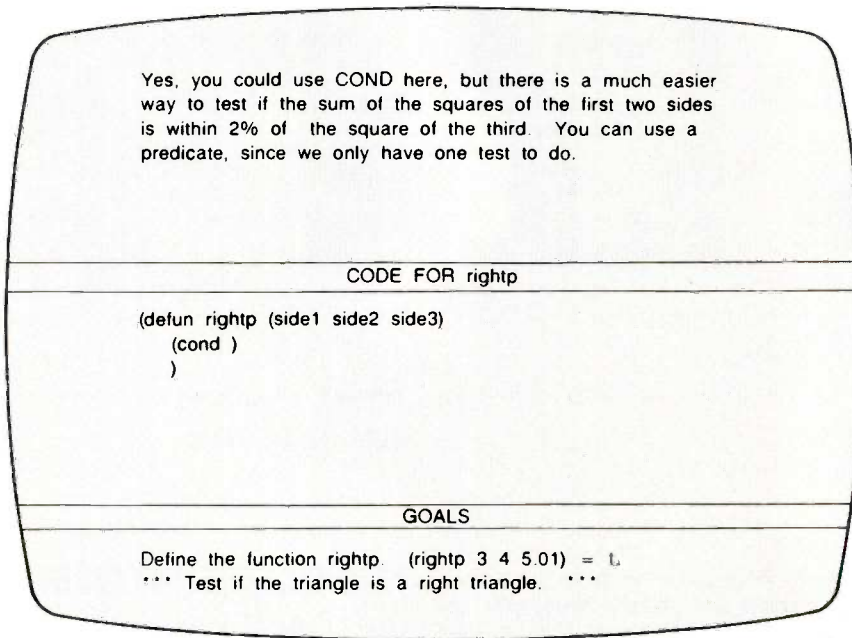

Figure 1: The screen configuration after line 1 in listing 1.

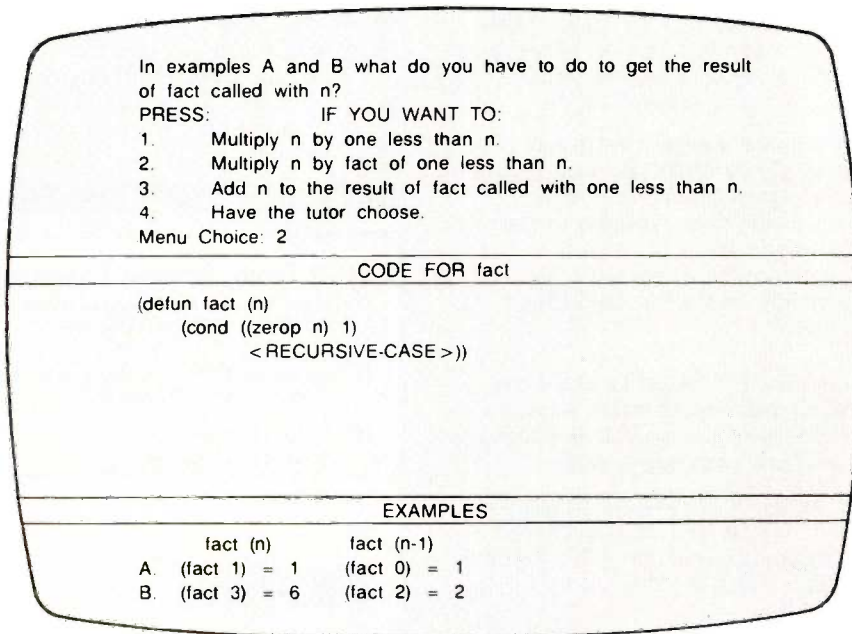

Figure 2: The screen configuration before line 4 in listing 2.



# POWERFUL CP/M® SOFTWARE

Diskette & Manual **\$29.95**

## NEVADA FORTRAN™ DISKETTE & MANUAL

Nevada FORTRAN is based upon the ANSI-66 standards (FORTRAN IV) with some 1977 level features. Advanced features include: IF... THEN... ELSE statement; COPY (Include); CHAINing with COMMON; and TRACE debugging. Package Includes a diskette, 214-page manual and 5 sample programs. Included also is an 8080 assembler. Requires 48K RAM.

**\$29.95**

## NEVADA COBOL™ DISKETTE & MANUAL

Nevada COBOL, based upon the ANSI-74 standards, has all the popular features. Powerful level 2 features include: compound conditionals and full CALL CANCEL. This software package includes a diskette, 165-page manual, plenty of examples and 16 complete COBOL source code programs.

**\$29.95**

## NEVADA BASIC™ DISKETTE & MANUAL

With the built-in, full-screen text editor, you can easily develop programs for 1/10 the cost of a comparable BASIC interpreter. What's more, Nevada BASIC has full Matrix operations, Single- and Multi-Line functions, and BCD math (no round-off errors). You get a diskette and a 220-page manual. Requires 48K RAM.

**\$29.95**

## NEVADA PASCAL™ DISKETTE & MANUAL

Advanced features include: 14-Digit precision; BCD math (no round-off errors); Floating point + 63 -64; TRACE debugging; Arrays up to 8 dimensions; 64K strings; External procedures; and Dynamic Module loading. You get a diskette and a 184-page manual. Requires 60K RAM and one disk drive with at least 90K storage.

**\$29.95**

## NEVADA PILOT™ DISKETTE & MANUAL

Nevada PILOT, written by Prof. John Starkweather, the language's creator, meets and exceeds all PILOT-73 standards. See the review in January 1983 MICROCOMPUTING. This package includes a diskette, 131-page manual, and 10 useful sample programs.

**\$29.95**

### WHY WAIT? ORDER YOURS TODAY!

Satisfaction guaranteed—or your money back. If for any reason you're not completely satisfied, just return the package—in good condition—with the sealed diskette unopened, within 15 days and we'll refund your money.

Checks must be in U.S. Dollars and drawn on a U.S. Bank.

California deliveries add 6% or 6.5% sales tax.

**SHIPPING AND HANDLING FEES:** Add \$4.00 for the first package or manual and \$2.00 each additional. **OVERSEAS:** Add \$15.00 for the first package or manual and \$5.00 each additional. **COD's:** Add \$4.00.

WE WELCOME C.O.D.'s



**(415) 753-0186**

**ELLIS COMPUTING, INC.**  
3917 Noriega Street  
San Francisco, CA 94122



Since 1977

**ELLIS COMPUTING™**

## NEVADA EDIT™ DISKETTE & MANUAL

Nevada EDIT, a full-screen, video-display text editor, is designed specifically for computer program text preparation. Nevada EDIT is completely user-changeable, can be configured to almost any terminal and takes up only 12K of disk space. This package includes a diskette and 59-page manual.

**\$29.95**

### ALSO AVAILABLE:

- ★ EXTRA MANUALS ..... \$14.95
- ★ COBOL Application Packages, Book 1 ..... \$ 9.95
- ★ BIG PRINT-Diskette ..... \$19.95

The CP/M Operating System, an 8080, 8085, or Z-80 (8-Bit) microprocessor, and 32K RAM are required, unless otherwise stated above.

### WHEN YOU ORDER, PLEASE SPECIFY ONE OF THE FOLLOWING DISKETTE FORMATS:

- |   |  |
|---|--|
| <input type="checkbox"/> 8" SSSD (Standard CP/M IBM 3740)             | <input type="checkbox"/> Kaypro Double Density (NCR)             |
| <input type="checkbox"/> 5 1/4" Diskettes for:                        | <input type="checkbox"/> Micropolis Mod II                       |
| <input type="checkbox"/> Access/Actrix                                | <input type="checkbox"/> NEC PC 8001                             |
| <input type="checkbox"/> Apple CP/M                                   | <input type="checkbox"/> North Star Double Density               |
| <input type="checkbox"/> DEC VT 180                                   | <input type="checkbox"/> North Star Single Density               |
| <input type="checkbox"/> DEC Rainbow                                  | <input type="checkbox"/> Osborne Single Density                  |
| <input type="checkbox"/> Epson QX-10                                  | <input type="checkbox"/> Sanyo 1000, 1050                        |
| <input type="checkbox"/> Heath Hard Sector (Z-89)                     | <input type="checkbox"/> Superbrain DD DOS 3.X<br>(512 byte sec) |
| <input type="checkbox"/> Heath Soft Sector<br>(Z-90, Z-100)           | <input type="checkbox"/> Televideo                               |
| <input type="checkbox"/> IBM-PC (Requires Z-80,<br>Baby Blue II Card) | <input type="checkbox"/> TRS-80 Model 1 (Base O Mapper)          |
|   | <input type="checkbox"/> Xerox 820 Single Density                |

CP/M is a registered trademark of Digital Research, Inc. Microsoft is a registered trademark of Microsoft Corp. TRS-80 is a registered trademark of Tandy Corp. Apple II is a trademark of Apple Computer, Inc. Osborne is a registered trademark of Osborne Computer Corp. Xerox 820 is a trademark of Xerox Corp. Kaypro is a trademark of Non-linear Sys. Heath/Zenith is a trademark of Heath Corp. IBM is a registered trademark of International Business Machines, Corp. Nevada BASIC, Nevada COBOL, Nevada FORTRAN, Nevada PILOT, Nevada EDIT, Nevada PASCAL, and Ellis Computing are trademarks of Ellis Computing, Inc. © 1984 Ellis Computing, Inc.



```

-- YOU ARE DONE. TYPE NEXT TO GO ON AFTER --
-- TESTING THE FUNCTIONS YOU HAVE DEFINED --

(defun fact (n)
  (cond ((zerop n) 1)
        (t (times n (fact (sub1 n))))))

THE LISP WINDOW

=> (trace fact)
(fact)

=> (fact 3)
1 <Enter> fact (3)
|2 <Enter> fact (2)
| 3 <Enter> fact (1)
| |4 <Enter> fact (0)
| |4 <EXIT> fact 1
| 3 <EXIT> fact 1
|2 <EXIT> fact 2
| 1 <EXIT> fact 6
6

```

Figure 3: The screen configuration at the end of the dialogue in listing 2.

lead students through a variety of correct solutions and respond to a wide range of errors. Thus, it is generative in the sense that it creates instructional interactions rather than using preprogrammed sequences.

Generally, students are happy with the tutor and rate it better than learning experiences they have had in other introductory programming courses. Their major complaints are that it uses too many menus and is sometimes slow. We are implementing optimizations and improvements to resolve both these problems. Interestingly, students are more appreciative of the tutor's guidance and more tolerant of its speed as the lessons increase in difficulty.

We have run one evaluation of the tutor, comparing it to experienced private human tutors and "on-your-own" condition. We found that the advantage of private tutoring—human or computer—over the on-your-own condition increased as the material became more difficult. The students finished lesson 1 basically with the same speed and success in all three conditions. However, those in the on-your-own condition often had great difficulty getting through the recursion material; in fact, some did not finish the material in the allotted time. We had to extrapolate how long it would have taken them to finish it. Averaging the actual and extrapolated times, the students took 11.4 hours with the human tutors, 15 hours with the computer tutor, and 26.5 hours "on-your-own" to learn six lessons. Polls of students in a traditional classroom suggest that it takes over 40 hours to cover the material in that situation.

We tested the three groups just before the recursion exercises. We found essentially identical performances even though they were learning at different rates. In another evaluation, we found students working with the tutor learned nine lessons of material faster and performed better on competence tests than students learning without the tutor. Thus, the basic conclusion is that the human

(continued)

## Subscription Problems?



### We want to help!

*If you have a problem with your BYTE subscription, write us with the details. We'll do our best to set it right. But we must have the name, address, and zip of the subscription (new and old address, if it's a change of address). If the problem involves a payment, be sure to include copies of the credit card statement, or front and back of cancelled checks. Include a "business hours" phone number if possible.*

**BYTE**  
 Subscriber Service  
 P.O. Box 328  
 Hancock, NH 03449



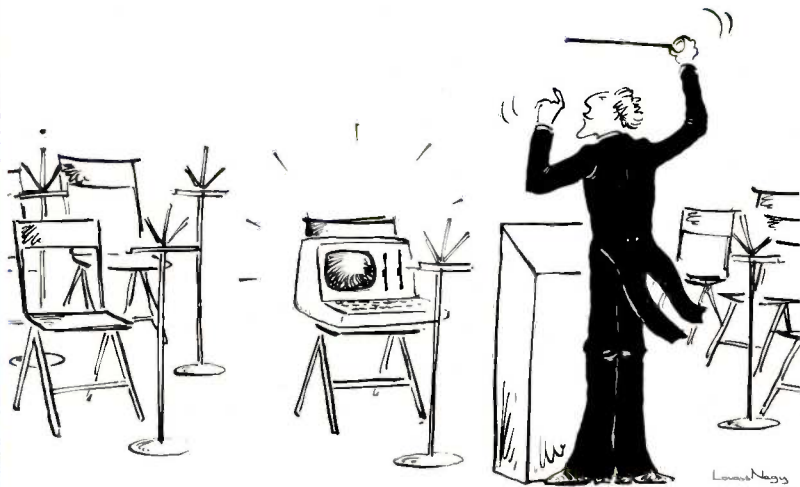

Would you hire an entire band when all you need is one instrument? Of course not.

So why use a whole orchestra of computers when all you need is one to develop software for virtually any type of micro-processor?

The secret? Avocet's family of cross-assemblers. With Avocet cross-assemblers you can develop software for practically every kind of processor — *without having to switch to another development system along the way!*

## Cross-Assemblers to Beat the Band!

### Development Tools That Work

Avocet cross-assemblers are fast, reliable and user-proven in over 4 years of actual use. Ask NASA, IBM, Xerox or the hundreds of other organizations that use them. Every time you see a new micro-processor-based product, there's a good chance it was developed with Avocet cross-assemblers.

Avocet cross-assemblers are easy to use. They run on almost any personal computer and process assembly language for the most popular microprocessor families.

### Your Computer Can Be A Complete Development System

Avocet has the tools you need to enter and assemble your soft-ware and finally cast it in EPROM:

**VEDIT Text Editor** makes source code entry a snap. Full-screen editing plus a TECO-like command mode for advanced tasks. Easy installation - INSTALL program supports over 40 terminals and personal computers. Customizable keyboard layout. CP/M-80, CP/M-86, MSDOS, PCDOS. . . . . \$150

**EPROM Programmers** let you program, verify, compare, read, display EPROMS but cost less because they communicate through your personal computer or terminal. No personality modules! On-board intelligence provides menu-based setup for 34 different EPROMS, EEPROMS and MPUs (40-pin devices require socket adaptors). Self-contained unit with internal power supply, RS-232 interface, Textool ZIF socket. Driver software (sold separately) gives you access to all programmer features through your computer, lets you download cross-assembler output files, copy EPROM to disk.

**Model 7228 Advanced Programmer** — Supports all PROM types listed. Super-fast "adaptive" programming algorithm programs 2764 in 1.1 minutes.

**Model 7128 Standard Programmer** — Lower-cost version of 7228. Supports all PROM types except "A" versions of 2764 and 27128. Standard programming algorithm programs 2764 in 6.8 minutes.

Avocet Cross-assembler	Target Microprocessor	CP/M-80	CP/M-86 IBM PC, MSDOS**
XASM04 <i>NEW</i>	6804	\$ 250.00	\$ 250.00
XASM05	6805	200.00	250.00
XASM09	6809	200.00	250.00
XASM18	1802/1805	200.00	250.00
XASM48	8048/8041	200.00	250.00
XASM51	8051	200.00	250.00
XASM65	6502/65C02	200.00	250.00
XASM68	6800/01, 6301	200.00	250.00
XASM75	NEC 7500	500.00	500.00
XASM85	8085	250.00	250.00
XASM400	COP400	300.00	300.00
XASMF8	F8/3870	300.00	300.00
XASMZ8	Z8	200.00	250.00
XASMZ80	Z80	250.00	250.00
XMAC682 <i>NEW</i>	68200	595.00	595.00
XMAC68K <i>NEW</i>	68000/68010	595.00	595.00

**Model 7956 and 7956-SA Gang Programmers** — Similar features to 7228, but program as many as 8 EPROMS at once. 7956-SA stand-alone version copies from a master EPROM. 7956 lab version has all features of stand-alone plus RS-232 interface.

**EPROM:** 2758, 2716, 2732, 2732A, 2764, 2764A, 27128, 27128A, 27256, 2508, 2516, 2532, 2564, 68764, 68766, 5133, 5143. **CMOS:** 27C16, 27C32, 27C64, MC6716. **EEPROM:** 5213, X2816A, 48016, I2816A, 5213H. **MPU (w/adaptor):** 8748, 8748H, 8749, 8749H, 8741, 8742, 8751, 8755.

<b>7228</b>	<b>Advanced Programmer</b>	<b>\$ 549</b>
<b>7128</b>	<b>Standard Programmer</b>	<b>429</b>
<b>7956</b>	<b>Laboratory Gang Programmer</b>	<b>1099</b>
<b>7956-SA</b>	<b>Stand-Alone Gang Programmer</b>	<b>879</b>
<b>GDX</b>	<b>Driver Software</b>	<b>95</b>
<b>481</b>	<b>8748 Family Socket Adaptor</b>	<b>98</b>
<b>511</b>	<b>8751 Socket Adaptor</b>	<b>174</b>
<b>755</b>	<b>8755 Socket Adaptor</b>	<b>135</b>
<b>CABLE</b>	<b>RS-232 Cable (specify gender)</b>	<b>30</b>

**HEXTRAN Universal HEX File Converter** — Convert assembler output to other formats for downloading to development systems and target boards. Also useful for examining object file, changing load addresses, extracting parts of files. Converts to and from Intel, Motorola, MOS, RCA, Fairchild, Tektronix, TI, Binary and HEX/ASCII Dump formats. For CP/M, CP/M-86, MSDOS, PCDOS. . . . . \$250

Ask about UNIX.

**68000 CROSS-ASSEMBLER** — With exhaustive field testing completed, our 68000 assembler is available for immediate shipment. XMAC68K supports Motorola standard assembly language for the 68000 and 68010. Macros, cross-reference, structured assembly statements, instruction optimization and more. Linker and librarian included. Comprehensive, well-written manual.

To find out more, call us toll-free.

**1-800-448-8500**

(in the U.S. Except Alaska and Hawaii)

VISA and Mastercard accepted. All popular disc formats now available — please specify. Prices do not include shipping and handling — call for exact quotes. OEM INQUIRIES INVITED.

\*Trademark of Digital Research \*\*Trademark of Microsoft



**Sales and Development:**

**10 Summer Street  
P.O. Box 490, Dept. 485-B  
Rockport, Maine 04856  
(207) 236-9055 Telex: 467210 AVOCET CI**

**Corporate Offices:**

**804 South State Street  
Dover, Delaware 19901**



# Why wait for ANSWERS FROM YOUR IBM PC/AT/XT NOW THERE'S MEGA-MATH™

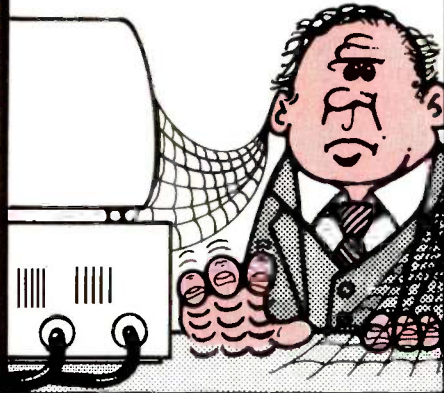

Engineers, scientists and statisticians are discovering the time saving capability of Mega Math. A library of over 40 assembly language sub-routines for fast numeric calculations, **up to 8 times faster!**

Routines use the 8087 or 80287 coprocessor for optimum performance.

Mega Math library includes:

- Matrix Operations**
- Vector Operations**
- Vector Scalar Operations**
- Statistical Operations**
- Fast Fourier Transform**
- Convolution**
- Solution of Linear Equations**
- Transcendental Functions**

Get Mega Math capability  
for

**\$9900**



**(403) 250-1437**

Bay 1, 4001A - 19 Street N.E.  
Calgary, Alberta Canada T2E 6X8

TM - MEGA MATH IS A TRADEMARK OF  
MICRAY ELECTRONICS LTD.

## LISP TUTOR

Listing 2: *The dialogue involved in defining the function fact, which computes the factorial of the number given.*

Define the function fact. It takes a number argument, n, and computes the factorial of n, which is the result of multiplying  $n \times n-1 \times n-2 \dots \times 1$ . For instance,  $(\text{fact } 3) = 3 \times 2 \times 1 = 6$ . By definition, the factorial of 0 is 1.

```
1. (defun fact (n)
   (cond ((equal) <ACTION>)
         <RECURSIVECASE>))
```

I assume that you are trying to test if the number argument is equal to the number zero. There is a special function for testing equivalence to zero. Try to use that function instead of equal.

What code can you write to test if the condition for terminating case is true? Try writing a predicate.

```
2. (defun fact (n)
   (cond ((zero <ACTION>)
         <RECURSIVECASE>))
```

Did you mean zero (y or n)? y

```
3. (defun fact (n)
   (cond ((zerop n) 1)
         <RECURSIVECASE>))
```

Is the value of fact in the recursive cases calculated by:

- PRESS: IF YOU WANT TO:
- 1 Calling fact recursively with n.
  - 2 Multiplying n by fact of n minus 1.
  - 3 Getting 1 2 . . . n and then multiplying the results.
  - 4 Have the tutor choose.

Menu choice: 3

That is a reasonable way to think of doing factorials but it is not a plan for a recursive function. Since you seem to be having trouble with the recursive cases let us work through some examples and figure out the conditions and actions for each of these cases.

The recursive relationship is the relationship between fact called with n and fact called with:

- PRESS: IF YOU WANT TO:
- 1 n minus 1
  - 2 n equal to 0
  - 3 n plus 1
  - 4 Have the tutor choose.

Menu choice: 1

We will consider some concrete examples. We will characterize the recursive relationship between fact called with 1 and fact called with 0.

What is the value of (fact 1)?

Answer: 1

What is the value of (fact 0)?

Answer: 1

### EXAMPLES

fact (n)      fact (n - 1)  
A. (fact 1) = 1      (fact 0) = 1

We will consider some more concrete examples. We will characterize the recursive relationship between fact called with 3 and fact called with 2.

What is the value of (fact 3)?

Answer: 6

(continued)



What is the value of (fact 2)?

Answer: 2

#### EXAMPLES

- fact (n)      fact (n - 1)  
 A. (fact 1) = 1    (fact 0) = 1  
 B. (fact 3) = 6    (fact 2) = 2

Since there is only one recursive case characterized by the examples you have just worked out, the condition in this case can be just coded as T. We will focus on characterizing the action in this case.

In examples A and B what do you have to do to get the result of fact called with n?

- PRESS:      IF YOU WANT TO:  
 1            Multiply n by one less than n.  
 2            Multiply n by fact of one less than n.  
 3            Add n to the result of fact called with one less than n.  
 4            Have the tutor choose.

Menu choice: 2

We have now worked through a series of examples that illustrate the recursive relation. We will now return to the goal of trying to produce LISP code that specifies the recursive relation.

4. (defun fact (n)  
   (cond ((zerop n) 1)  
       (t (fact ))))

You will have to use fact at some point but right now you want to multiply.

5. (defun fact (n)  
   (cond ((zerop n) 1)  
       (t (times <NUM> <NUM2>))))

What do you want to do first?

- PRESS:      IF YOU WANT TO:  
 1            Write code to get the number argument.  
 2            Write code to get the recursive part.

Menu choice: 1

6. (defun fact (n)  
   (cond ((zerop n) 1)  
       (t (times n (fact n)))))

You cannot just code n at this point. What you want to do is subtract one from n.

7. (defun fact (n)  
   (cond ((zerop n) 1)  
       (t (times n (fact (difference ))))))

difference would work in this case but it is more appropriate to use the function sub1 when you are subtracting 1 from a number.

8. (defun fact (n)  
   (cond ((zerop n) 1)  
       (t (times n (fact (sub1 n))))))

tutor is still best, the computer tutor not that far behind (and constantly improving), and the traditional on-your-own condition much worse.

### TODAY AND TOMORROW

Currently, we get satisfactory performance of the tutor on a VAX 725 with

3 megabytes of memory devoted to a single student. Our planned optimizations should enable it to handle a pair of students simultaneously running on the same machine. These implementations are cost-effective in expensive private schools like CMU or in industry; however, they are clearly

out of range for the general public. The amount of computational power required is considerable. Even in future, more efficient implementations we estimate a minimum of 1 megabyte of memory will be necessary to tutor one student on one machine. By the late 1980s the computational power to deliver such instruction should be more generally available. For instance, in conjunction with IBM, CMU is planning to have on campus by 1986 a personal computer with 1 megabyte of memory capable of 1 million instructions per second. Such a machine will be more than adequate to implement the LISP tutor.

These technological trends encourage optimism about the future of intelligent tutoring efforts, of which the LISP tutor is one. We hope that, with continued research in domains such as high-school mathematics and college-level programming, we will soon establish the conceptual foundations to use the computational power that will be available. The prospect is great of providing every student with the educational benefits of a private human tutor. When this happens, the consequences for American education will be nothing short of revolutionary. ■

### ACKNOWLEDGMENT

This research is supported by Office of Naval Research under Contract No. N00014-84-0064. We would like to acknowledge the considerable contributions of Robert Farrell, Elliot Jaffe, Beth Marvel, and Peter Pirolli to the research on the LISP tutor.

### REFERENCES

1. Bloom, B. S. "The 2 Sigma Problem: The Search for Methods of Group Instruction as Effective as One-to-One Tutoring." *Educational Researcher*, 13, 1984, page 3.
2. Sleeman, D., and J. S. Brown, eds. *Intelligent Tutoring Systems*. New York: Academic Press, 1982.
3. Anderson, J. R., R. Farrell, and R. Sauers. "Learning to Program in LISP." *Cognitive Science*, 8, 1984, page 87.
4. Sauers, R., and R. Farrell. *GRAPES User's Manual*. Technical Report ONR-82-3. Pittsburgh: Carnegie-Mellon University, 1982.
5. Carroll, J. M. "Minimalist Training." *Datamation*, November 1984, page 125.



# WE'LL ALWAYS BE RIGHT WHERE YOU WANT US.

Every 7 days we open a new hotel in a place you need to be.





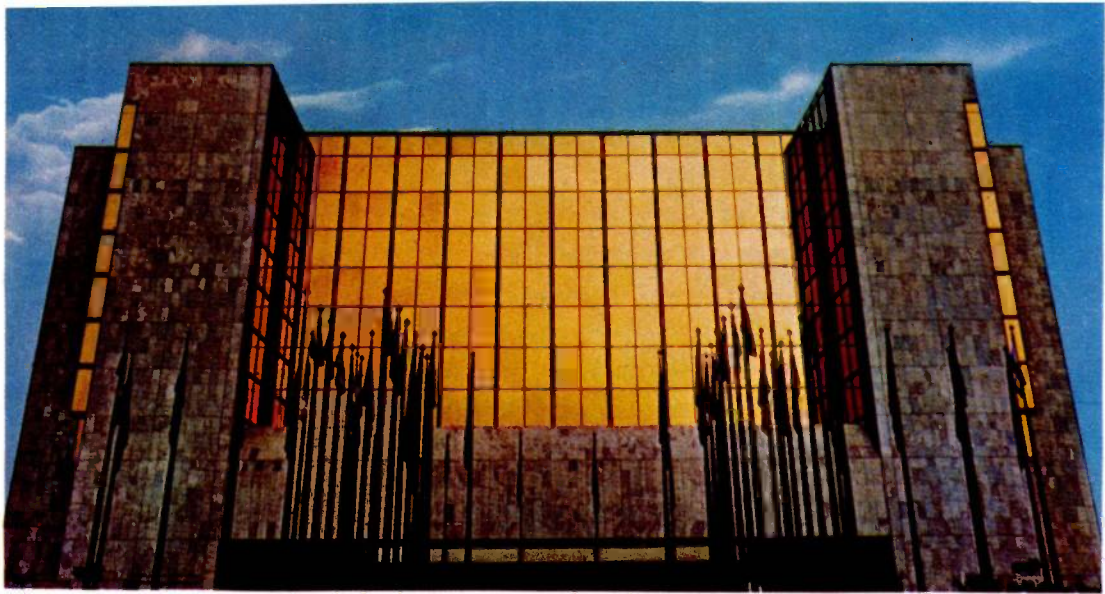

*As the world's hotel leader, we're creating more hotels in more of the places you want... in cities and towns, near airports, business centers and resorts... with more than 50 Holiday Inn® hotels opening this year in the most convenient locations.*

*1700 Holiday Inn hotels, built right where you need them... in exciting resorts and on secluded beaches, near convention facilities, in quiet countrysides and major capitals all around the world.*

*We're building hotels in the best locations, making Holiday Inn "a better place to be."™ Business travelers agree: when naming their first choice in lodging, they choose Holiday Inn hotels number one over all competitors. Which*

*makes 1-800-HOLIDAY the number to call for all your travel reservations.*

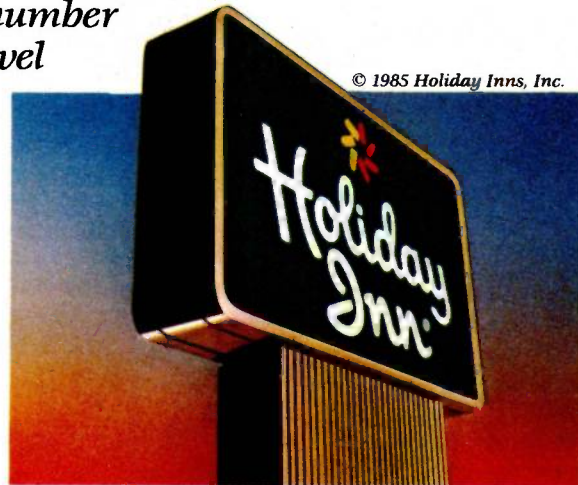
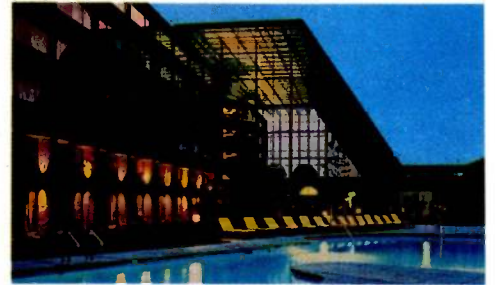

© 1985 Holiday Inns, Inc.

**HOLIDAY INN.® A BETTER PLACE TO BE.**



# Now your IBM PC and AT can read

## The OMNI-READER

The OMNI-READER is a revolutionary new Text Reader or Optical Character Reader (OCR).

It costs a fraction of the price of your computer system. It reads the printed word and translates it into an electronic signal capable of being recognized and down loaded into most computers and word processors. The need for slow and tedious retyping of already printed data is eliminated.

The quick brown fox can jump from the OMNI-READER into your micro computer system and onto the screen with as little effort as it takes to read "The quick brown fox."

BY ...



## The OMNI-READER

The OMNI-READER is a revolutionary new Text Reader or Optical Character Reader (OCR).

It costs a fraction of the price of your computer system. It reads the printed word and translates it into an electronic signal capable of being recognized and down loaded into most computers and word processors. The need for slow and tedious retyping of already printed data is eliminated.

The quick brown fox can jump from the OMNI-READER into your micro computer system and onto the screen with as little effort as it takes to read "The quick brown fox."

BY ...



With the Oberon OMNI-READER™ — the first optical character reader designed and priced for small computers.

Now you can transfer material directly from the typed page to the screen of your computer, without ever touching the keyboard — using specially designed interface software that allows input directly into your spreadsheet, database and word processing applications program.

And because the OMNI-READER uses a standard RS232 serial port hookup, it interfaces easily with *your* computer.

The technology is revolutionary. But what is most revolutionary is the price — under \$500. IBM interface software, \$50.

Find out more about the Oberon OMNI-READER. Dial 800-2-OBERON. In Texas, (214) 446-9567.

IBM is a registered trademark of International Business Machines.

Inquiry 286

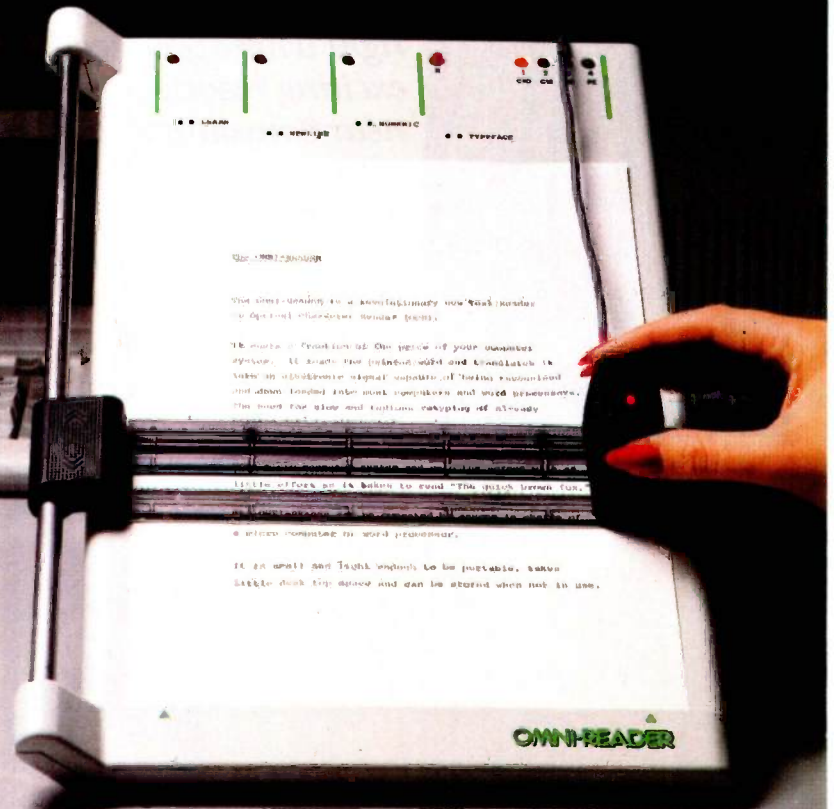

**OBERON**  
INTERNATIONAL



## PROUST

BY W. LEWIS JOHNSON AND ELLIOT SOLOWAY

### *An automatic debugger for Pascal programs*

PROUST (Program Understander for Students) is a knowledge-based system that finds nonsyntactic bugs in Pascal programs written by novice programmers. When students compile a program successfully, PROUST is automatically invoked to analyze it. PROUST reports any bugs that are in the program to the student.

PROUST is not merely a tool that helps programmers find bugs, nor is it confined to a narrow class of bugs, such as uninitialized variables. It is designed to find *every* bug in most beginners' programs. PROUST is currently capable of correctly identifying all of the bugs in over 70 percent of the programs that students write when we assign them moderately complex programming problems. When PROUST finds a bug, it does not simply point to the lines of code that are wrong; instead, it determines how the bug can be corrected and suggests why the bug arose in the first place. Our aim is to build an instructional system around PROUST that assigns programming problems to students, reads their work, and gives them helpful suggestions.

In designing PROUST we found it necessary to deal directly with the

variability of bugs in beginners' programs. If a programming problem is assigned to a class of 200, the students will write 200 different programs (assuming that they do not cheat). There is variability both in their programs' designs and bugs. Some bugs, such as missing variable initializations, are accidental omissions that can be easily recognized and corrected. Other bugs result when the programmer fails to reason through the interactions between components. In isolation, each piece of the program may appear correct, but when combined, the program doesn't work. Still other bugs result from misconceptions about programming. The code may appear correct to the programmer, but it doesn't do what he or she expects, for reasons he or she does not understand. Bugs resulting from misconceptions are the most serious; students stand to benefit the most from having such problems pointed out to them.

If a debugging system is to cope with the various types of errors that programmers make, it must understand what the programmer is trying to do. Debugging systems usually don't concern themselves with what

the program is supposed to do, they only analyze what the program actually does (see references 1, 2, and 3). Figuring out how a program is supposed to work is not easy; to do it a debugger requires information about the programming problem and knowledge about how to write programs. Nevertheless, identifying the programmer's intentions is worth the effort, because this knowledge makes it possible to identify more bugs, as well as to understand their causes.

To show how knowledge of the pro-

*(continued)*

W. Lewis Johnson (POB 2158, Yale Station, New Haven, CT 06520) is a research associate at Yale. He has a B.A. from Princeton University and a Ph.D. from Yale University. His interests are artificial intelligence, software engineering, and computer-aided instruction. Dr. Johnson has been pursuing research in artificial intelligence at Yale since 1978.

Elliot Soloway (Department of Computer Science, Yale University, New Haven, CT 06520) is an assistant professor at Yale. He has a B.A. in philosophy and a Ph.D. in computer science from the University of Massachusetts at Amherst. Dr. Soloway heads a group at Yale that is exploring the cognitive underpinnings of programming.



grammer's intentions assists debugging, we will present two examples of "buggy" programs and discuss why alternative approaches to automatic debugging fail to identify such bugs. Then we will describe how PROUST analyzes such programs. Finally, we will present some statistics showing PROUST's performance on large numbers of students' solutions to a typical assignment in an introductory programming class. This will help support our claim that PROUST's approach is adequate for the majority of novice programmers' programs.

### EXAMPLES OF PROGRAM BUGS

Here is a simple programming problem called the Averaging Problem:

Write a program that reads in a sequence of positive numbers, stopping when 99999 is read. Compute the average of these numbers. Do not include the 99999 in the average. Be sure to reject any input that is not positive.

The student's program must compute the average of a series of positive numbers. It must ensure that the input to the program is in fact positive. The input terminates when a specific value—99999—is read. Values such as this, which signal the end of input, are called *sentinel values*.

Figure 1a shows a sample solution to the Averaging Problem. This program works except for the following

bug: if you type 99999 immediately after typing a nonpositive value, the program will continue to prompt for data after the 99999 is read. When the program finally does terminate, the average will be incorrect. For example, suppose that you input 5, -5, 99999. Instead of terminating when the 99999 is read, the program requests another input. If the user then entered another 99999, the program would not print the average as 5, but instead would print  $(5+99999)/2$ , or 50002.

The program interprets 99999 as data when the sequence 5, -5, 99999 is read because when the program reads the -5, it enters the input-validation loop, which starts with line 10, WHILE Val <= 0 DO. This loop is intended to iterate until a positive value is typed in; 99999 is positive, so when the 99999 is read, control leaves the input-validation loop. However, the program was written with the assumption that when the input-validation loop is exited, the current value of Val is valid input data. In this case, Val is not valid data; it is 99999, the sentinel value. The loop nevertheless processes 99999 as if it were data. To guard against this case, there should be a test for the sentinel after the input-validation loop.

Figure 1b is PROUST's output describing the missing sentinel-test bug. The error is described in two ways: First it is described in English; then PROUST generates an example of data that causes the program to fail.

Now look at the program in figure 2a. This is another solution to the Averaging Problem, and the bug in this program is also fairly obscure. If you type a positive value followed by a negative value, the negative value will be included in the average. Thus if you type -2, 2, 99999, the average will be 2, but if you type 2, -2, 99999, the average will be 0.

Unlike the example in listing 1a, the programmer has not left out the sentinel test but has written the test in the form of a WHILE statement instead of an IF statement. The student probably has a misconception about the distinction between the two state-

(a)

```

1 PROGRAM Average( Input, Output );
2   VAR Sum, Count, Val, Avg: REAL;
3   BEGIN
4     Sum := 0;
5     Count := 0;
6     Writeln( 'Enter Value:' );
7     Read( Val );
8     WHILE Val < > 99999 DO
9       BEGIN
10        WHILE Val <= 0 DO
11          BEGIN
12            Writeln( 'Invalid entry, reenter' );
13            Read( Val );
14          END;
15        Sum := Sum + Val;
16        Count := Count + 1;
17        Writeln( 'Enter value:' );
18        Read( Val );
19      END;
20    IF Count > 0 THEN
21      Writeln( 'No data entered' )
22    ELSE BEGIN
23      Avg := Sum/Count;
24      Writeln( 'The average is,'Avg );
25    END;
26  END.
```

(b)

PROUST's output:

You're missing a sentinel test. If a sentinel value is input immediately following a nonpositive value, your program will treat it as valid data.

To see this, try the following data in your program:

5 -5 99999

Figure 1: (a) One novice programmer's attempt at implementing the Averaging Problem. (b) PROUST explains the bug lurking in the program in concise English sentences and even offers data illustrating the error.



ments and does not understand how the control flow in a WHILE loop works. As long as the body of the loop is straight-line code, the student has no problem. However, if the body of the loop contains tests, the student thinks that the tests should be written as WHILE statements to ensure that they repeat when the body of the loop does. We will refer to this misconception henceforth as the WHILE-for-IF misconception. PROUST's output for this example, shown in figure 2b, takes the misconception into account and explains it to the student.

The bugs in figures 1a and 2a illustrate the following points. First, bugs frequently cannot be detected if you don't know what the program is supposed to do. Both of the programs shown run no matter what input is read; to determine that there is a bug, you must recognize that the programs output different results than they should. Bugs such as these are not unusual; the missing sentinel-test bug occurs in 18 percent of novice programmers' solutions to the Averaging Problem.

Second, novice programmers need help identifying such bugs. These bugs cause the programs to fail only after unusual inputs—ones that novice programmers are unlikely to test. In the case of the WHILE-for-IF misconception, even if the programmer tests the case in question, he or she will probably not understand why the program fails because he or she expects the WHILE statement to perform a different function than it actually does.

### ALTERNATIVES TO INTENTION-BASED DEBUGGING

To support our claim that debugging requires knowledge of the programmer's intentions, we will examine the principal alternatives to intention-based debugging and show why they fall short. The methods we have considered are analysis of I/O (input/output) behavior, analysis of data flow, and recognition of patterns of buggy code.

Debugging by analyzing I/O behavior involves determining when the

(a)

```

1 PROGRAM Average( Input, Output );
2   VAR Sum, Count, Val, Avg: REAL;
3   BEGIN
4     Sum := 0;
5     Count := 0;
6     Writeln( 'Enter value:' );
7     Read( Val );
8     WHILE Val < > 99999 DO
9       BEGIN
10        WHILE Val < = 0 DO
11          BEGIN
12            Writeln( 'Invalid entry, reenter' );
13            Read( Val );
14          END;
15        WHILE Val < > 99999 DO
16          BEGIN
17            Sum := Sum + Val;
18            Count := Count + 1;
19            Writeln( 'Enter value:' );
20            Read( Val );
21          END;
22        END;
23        IF Count = 0 then
24          Writeln( 'No data entered' )
25        ELSE BEGIN
26          Avg := Sum/Count;
27          Writeln( 'The average is:Avg' );
28        END;
29      END.

```

(b)

PROUST's output:

You are using a WHILE statement at line 15 where you should have used an IF statement. You probably want the code starting at line 15 to execute once each time through the loop; your code will make it execute many times.

The statement in question is:  
 WHILE Val < > 99999 DO ...

Figure 2: (a) Another novice programmer's attempt at implementing the Averaging Problem. (b) PROUST once again explains what the problem with the program is, what the programmer wanted to do, and what he actually did.

output of the program is incorrect and suggesting bugs that might have caused the faulty behavior (see reference 2). This approach treats debugging as similar to medical diagnosis (see reference 4). The faulty behavior can be thought of as the symptoms of the program, and the bugs can be thought of as the diseases. There are two problems with this approach: A program's symptoms cannot always be determined, and these symptoms cannot always be related to the bugs. The bugs in the programs in figures 1a and 2a affect the output of the program only occasionally; recognizing

when this happens requires knowledge about what the output should look like. Since the WHILE-for-IF example fails to test the input for validity after the first positive value is read, it appears that this program is missing an input-validation test. It is only after inspecting the code that it becomes clear that the bug is not in the input-validation test but in the sentinel test.

Another debugging approach you might try is data-flow analysis (see reference 1). This is the approach many error-checking compilers use.

(continued)



Data-flow analysis checks for clear anomalies in the pattern of data definition and for use of data in a program. It can determine when a variable is defined and never used or when a variable is never defined. However, if there are no anomalies in data flow, data-flow analysis will not detect any bugs. Neither example in the preceding section has data-flow anomalies, so this method would not detect the bugs.

You might also try analyzing the structure of the program itself to see whether it suggests the presence of bugs. You could build a library of templates for common bugs, such as missing sentinel tests or WHILE statements in place of IF statements, and then match these templates against the program to identify the bugs. The problem with this approach is that you have no way of knowing where to match the bug templates in the program. For example, the WHILE-for-IF example has three different WHILE loops. How could you tell which WHILE loop really should be an IF statement or if any of them should be an IF statement? You could try to make the bug template more specific by making it apply only when there are two loops with the same exit test, one inside the other. But that would make the template too specific; it would not apply to other cases where WHILE statements appear instead of IF statements.

All of these approaches to debugging attempt to identify bugs without any understanding of what the program is supposed to do, and any such approach does little more than make guesses as to what bug is involved. In order to do better, a debugging system has to be able to infer the programmer's intentions and relate them to the code.

### PROUST'S APPROACH

PROUST is written in T, a dialect of LISP. The full system contains roughly 15,000 lines of LISP code and runs on a VAX-11/750. A stripped-down version called Micro-PROUST has been developed in conjunction with Courseware Inc., of San Diego, Califor-

## MICRO-PROUST FOR THE IBM PC

Micro-PROUST is a subset of the larger implementation of PROUST. It is capable of dealing with a limited range of novice programs and is currently set up to handle only those example solutions to the Averaging and Rainfall Problems provided with it. Micro-PROUST runs in Gold Hill Computers Inc. Golden Common LISP on an IBM Personal Computer with 512K bytes of memory. The source code and example programs are available for downloading from BYTEnet Listings. The telephone number is (603) 924-9820. The file PRSTREAD.ME contains directions on how to run Micro-PROUST.

nia (see the text box "Micro-PROUST for the IBM PC" above for more information). Micro-PROUST is capable of recognizing the kinds of bugs that are described in this article; however, there are a variety of tricky bugs that PROUST can identify but Micro-PROUST cannot. (If you are interested in PROUST's full diagnostic capabilities, consult reference 3.)

PROUST's analysis of programs is based on knowledge of the programming problem. Students may solve the problem in a variety of ways and their programs may have a variety of bugs, but they are all trying to solve the same problem. Knowledge of the problem makes the variability of novice solutions more manageable. It also provides important information about the programmer's intentions.

To provide PROUST with descriptions of the programming problems, we devised a problem-description language. We described each problem in this language and provided PROUST with a library of the descriptions. Each problem description in PROUST's problem-description language is a paraphrase of the English-language problem statement that we

hand out to students.

To understand the students' programs, PROUST also needs to know how to solve the problem. Solutions to a given programming problem may be implemented in a variety of different ways. Suppose that there was only one way to test input for validity in a Pascal program, namely, to insert a WHILE loop at the top of the main loop, such as in figures 1a and 2a. Once PROUST knew that a program must validate input, it would know to look for such a loop, as well as for the sentinel test that must follow. However, there are several ways of validating input. Listing 1 shows a loop that tests input in a different way. Instead of there being one input validation loop, there are two; one is at the bottom of the loop and the other precedes the loop. No additional sentinel test is required when this method is used, because, as soon as input is validated, control flows to the main exit test of the WHILE loop. Therefore, without knowing what method the programmer is using for validating input, PROUST cannot tell whether to look for a sentinel test within the body of the loop. In figure 1a it is an error not to have such a sentinel test, but in listing 1 it is not. PROUST needs knowledge about programming so that it can understand how each student designed and implemented his or her solution. Once it understands the programmer's intentions, it can then use knowledge about common bugs to identify them in the student's program.

PROUST analyzes programs by synthesis. When PROUST examines a program, it looks up the corresponding problem description in its library. It makes hypotheses about the methods programmers may use to satisfy each requirement in the problem description. Each hypothesis is a possible correct implementation of the corresponding requirement. If one of these hypotheses fits the student's code, then PROUST infers that the requirement is implemented correctly. If PROUST's hypotheses do not fit the student's program, then PROUST checks its database of com-



mon bugs to see if it can explain the discrepancies.

### PROUST'S PROBLEM DESCRIPTIONS

Problem descriptions in PROUST consist of programming goals and sets of data objects. Programming goals are the principal requirements that must be satisfied; sets of data objects are the data that the program must manipulate.

The first step in translating an English-language problem statement into PROUST's problem-description language is to make the various goals that are mentioned in the problem statement explicit. Recall that the text of the Averaging Problem is the following:

Write a program that reads in a sequence of positive numbers, stopping when 99999 is read. Compute the average of these numbers. Do not include the 99999 in the average. Be sure to reject any input that is not positive.

Solutions to this problem operate on a sequence of input data; let us call this sequence *New*. The following goals can be extracted from the problem statement:

- Read successive values of *New*, stopping when a sentinel value, 99999, is read.
- Make sure that the condition  $New \leq 0$  is never true.
- Compute the average of *New*.
- Output the average of *New*.

We must now take these goals and use them to generate a problem description for PROUST. Each data object that the goals refer to is named and declared. Each goal extracted from the problem statement is recorded in the problem description. The resulting problem description is shown in figure 3.

Like all the data structures that we discuss in this article, problem descriptions are in list notation and every statement and expression is enclosed in parentheses. The name of the program is indicated with a Define-Program statement. Objects

Listing 1: Yet another way to implement the input validation for the Averaging Problem.

```

Read( Val );
WHILE Val <= 0 DO
  BEGIN
    Writeln( 'Invalid entry, reenter' );
    Read( Val );
  END;
WHILE Val < > 99999 DO
  BEGIN
    Sum := Sum+Val;
    Count := Count+1;
    Writeln( 'Enter value:' );
    Read( Val );
    WHILE Val <= 0 DO
      BEGIN
        Writeln( 'Invalid entry, reenter' );
        Read( Val );
      END;
  END;
END;
    
```

are named using Define-Object statements. Goals are indicated using Define-Goal statements.

Object names are preceded by question marks. There are two objects defined in the Averaging Problem description, ?Sentinel and ?New. The question-mark notation is used frequently in artificial-intelligence (AI) programs; it indicates that the variable is not a literal value but is a parameter that must be substituted when the data structure is used. For example, the input-data object ?New will be substituted with the name of the Pascal variable that the student uses for storing the input data. The object ?Sentinel has the value 99999; wherever ?Sentinel appears in the problem description it can be substituted with 99999.

Objects can be either constant-valued or variable-valued. In this example, ?Sentinel is a constant, with the value 99999, and ?New is a variable. In PROUST's general problem-description language objects can have a variety of properties associated with them; however, we will not use any such properties in this simple example.

Goal statements consist of a name of a type of goal, followed by a list of arguments. In the form (Average ?New) for example, Average is a type of goal (to compute an average), and ?New is the argument of the goal. This form requires that the program compute the average of ?New.

Arguments to goal expressions can take a variety of forms. They can be objects, predicates, or even other goal expressions. In the expression (Input-Validation ?New ( $\leq$  ?New 0)), one argument is an object (?New), and the other is a predicate  $?New \leq 0$ . In LISP, function names and operators precede their arguments, which is why the  $\leq$  precedes the ?New and 0 in the expression ( $\leq 0$ ). If goals are nested, as in (Output (Average ?New)), the outer goal refers to the value computed by the inner goal. Thus this goal requires that the program output the average of ?New.

In this example PROUST's problem descriptions are a reasonable approximation of the original English-language problem statements. These problem descriptions describe what the programs must do but not how they are supposed to do it. PROUST must analyze each individual program and determine how it is intended to satisfy the problem requirements.

### PROGRAMMING KNOWLEDGE

Programming knowledge in PROUST is frame-based (see reference 5). In frame-based systems knowledge is organized into frames, each of which corresponds to a particular concept that the system "knows" about. Frames are similar to records in relational databases, although the operations that can be performed on frames are somewhat different. Knowledge in frames is organized into slots, which function as record field names, and fillers, which are the values assigned to each slot.

The two kinds of programming knowledge that we will consider here are goals and plans (other types of programming knowledge are discussed in reference 6). Goals are problem requirements that appear in

(continued)



problem descriptions. Plans are stereotypic methods for implementing goals. A large part of writing programs consists of identifying goals that must be satisfied and selecting plans to implement these goals. Similarly, PROUST retrieves plans from its knowledge base for each goal referred to in the problem description. It compares these plans to the student's program to determine which fits the program best.

Figure 4 shows PROUST's definition for the Sentinel-Controlled-Input goal. The goal definition contains a series of slots: InstanceOf, Form, MainSegment, etc., together with fillers for each of these slots: Read&Process,

MainLoop;, ?New, etc. These slots serve various functions, only some of which we will discuss here. The most important slots are the Instances and InstanceOf slots. The Instances slot lists the various plans in PROUST's knowledge base for implementing this goal. This slot's filler is a list of five items, each of which is the name of a plan. The InstanceOf slot indicates the class to which this goal belongs. The goal class in this case is Read&Process, which is the class of all goals that involve reading a sequence of values and processing them.

Figure 5 shows a plan, the Sentinel-Process-Read-While plan. This is one of the instances of the Sentinel-

Controlled-Input goal. This plan is a simplified version of the one PROUST actually uses. Plans are also defined in terms of slots and fillers. The most important slot is the Template slot, which describes the form the Pascal code implementing this plan should take. Plan templates consist of Pascal statements, subgoals, and labels. The Pascal statements are written in list notation rather than ordinary Pascal syntax; for example, the form (WHILE (< > ?Input ?Stop) . . .) in Pascal syntax would appear as WHILE ?Input < > ?Stop DO . . . . Symbols that are preceded by question marks are pattern variables; these are substituted when the plan is used. ?New is substituted by a Pascal variable containing the input data, and ?Stop is substituted by a constant, the sentinel value. The ?\* statement is a "wild card" pattern that can be substituted by an arbitrary sequence of Pascal statements; this is just a placeholder in the plan. Subgoals are indicated by (SUBGOAL . . .) forms in the template; these are goals that must in turn be implemented using other plans.

```
((Define-Program Average)
(Define-Object ?New)
(Define-Object ?Sentinel Value 99999)
(Define-Goal (Sentinel-Controlled-Input ?New ?Sentinel))
(Define-Goal (Input-Validation ?New (< = ?New 0)))
(Define-Goal (Output (Average ?New))))
```

Figure 3: The Averaging Problem translated into PROUST's problem-description language.

```
(Goal-Definition Sentinel-Controlled-Input
  InstanceOf      Read&Process
  Form            (Sentinel-Controlled-Input ?Input ?Stop)
  MainSegment     MainLoop:
  MainVariable    ?New
  NamePhrase      "sentinel-controlled loop"
  OuterControlPlan T
  Instances       (Sentinel-Process-Read-While
                  Sentinel-Read-Process-While
                  Sentinel-Read-Process-Repeat
                  Sentinel-Process-Read-Repeat
                  Bogus-Counter-Controlled-Loop))
```

Figure 4: The definition of the goal Sentinel-Controlled-Input in PROUST's problem-description language.

```
(Plan-Definition Sentinel-Process-Read-While
  Constants      (?Stop)
  Variables      (?Input)
  Template       ((SUBGOAL (Input ?Input))
                  (WHILE (< > ?Input ?Stop)
                      (BEGIN
                       ?*
                       (SUBGOAL (Input ?Input))))))
```

Figure 5: A plan for implementing the goal Sentinel-Controlled-Input.

### MATCHING PLANS

Let's look at how plans and goals are used to understand a program. The plan in listing 1 has been implemented correctly. You will see how PROUST hypothesizes a plan that the program might use and then matches this plan against the program. In this case the match succeeds because the plan is implemented correctly. In the next section we will examine what happens when plans fail to match because the student's code has bugs.

The first step, before any analysis of goals and plans takes place, is to parse the student's Pascal program. This results in a parse tree. All subsequent analysis of the program is performed on the parse tree rather than on the original program text.

When PROUST analyzes a program, it selects goals from the problem description one at a time. Let's suppose that the goal that is selected first is (Sentinel-Controlled-Input ?New ?Sentinel). PROUST substitutes any

(continued)



# CAN THE JUKI® 6300 REALLY PRINT OVER 500 LETTERS IN 8 HOURS? STAND BACK AND WATCH!

Busy offices, take note: Our new letter-quality printer zips along at **40 characters per second** and sells for only **\$995**. Its 13" print line will handle your spreadsheets and every imaginable kind of correspondence—plus graphics! Quiet, too—less than 60 dbA. And the 3K buffer memory (expandable to 15K) lets you use your computer for other purposes while the JUKI is printing. Compatible with most computers. (You can even get an optional tractor feed and cut-sheet feeder for it!) Now you know why JUKI printers are humming in offices all over the world!

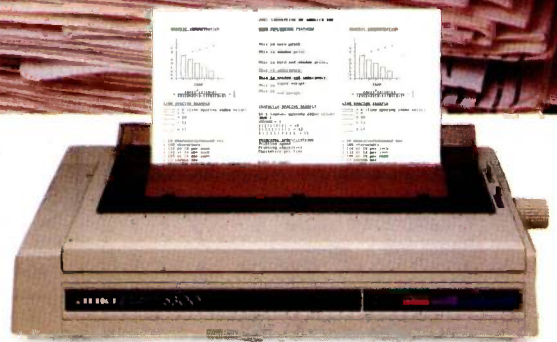

## JUKI®

**The worker.**  
JUKI OFFICE MACHINE CORP.

### EAST COAST:

299 Market St., Saddle Brook, NJ 07662  
(800) 932-0590

### WEST COAST:

23844 Hawthorne Blvd., Suite 101, Torrance, CA 90505  
(800) 325-6134 • (800) 435-6315 (California)



**PROUST substitutes any objects whose values are already known into the goal expression.**

objects whose values are already known into the goal expression. At this point the only information available about ?New and ?Sentinel is what appears in the problem description. There the value of ?Sentinel is listed as 99999, but the value of ?New is not listed. Therefore, the value of ?Sentinel is substituted into the goal expression, but ?New is left unchanged. The resulting goal expression is (Sentinel-Controlled-Input ?New 99999).

PROUST must now retrieve from its programming knowledge base plans that could be used to implement the goal Sentinel-Controlled-Input. It retrieves the filler of the Instances slot of the definition of Sentinel-Controlled-Input shown in figure 4. This

filler is a list of five items: Sentinel-Process-Read-While, Sentinel-Read-Process-While, Sentinel-Read-Process-Repeat, Sentinel-Process-Read-Repeat, and Bogus-Counter-Controlled-Loop. Each of these is the name of a plan. PROUST selects the first plan from the list, Sentinel-Process-Read-While. This will be PROUST's initial hypothesis of how the program implements the goal Sentinel-Controlled-Input.

Just as known values of objects were substituted into the goal expression (Sentinel-Controlled-Input ?New ?Sentinel), these same substitutions must now be performed on the selected plan. To see what substitutions must be made, PROUST examines the Form slot of the definition of Sentinel-Process-Read-While, (Sentinel-Controlled-Input ?Input ?Stop). The Form slot indicates which pattern-variable names are used in the plans that implement the goal. By comparing the Form slot to the goal being analyzed, PROUST determines that each occurrence of ?Input in the selected plan should be replaced by the value of ?New. Each occurrence of ?Stop should be replaced by the value of ?Sentinel or 99999. Because the value of ?New is not known,

PROUST simply replaces ?Input with the variable name ?New. PROUST assumes that the process of matching the plan against the program will determine what the value of ?New is.

Figure 6 shows how the Sentinel-Process-Read-While plan is matched against the program example in figure 1a. Matching starts with the WHILE loop. The pattern in the plan for the WHILE loop is (WHILE (<> ?New 99999) ...). There are two WHILE loops in this program: WHILE Val <> 99999 DO ... and WHILE Val <= 0 DO ... PROUST tries to match each pattern against each of these statements. (WHILE (<> ?New 99999) ...) matches WHILE Val <> 99999 DO ..., provided that Val is substituted for ?New. (WHILE (<> ?New 99999) ...) does not match WHILE Val <= 0 DO ... because the statement has a <= test instead of a <> test, and because it tests against 0 instead of 99999. Therefore PROUST selects WHILE Val <> 99999 DO ... as the match for the plan pattern. Since Val must be substituted for ?New so that the pattern matches, Val is recorded as the binding for ?New. Afterward, any component of the plan that has ?New in it will have Val substituted for ?New.

The next plan component that PROUST matches against the program is (BEGIN ...). There are several different BEGIN statements in the program that could be matched against this pattern. However, in the plan template the (BEGIN ...) pattern appears inside of the WHILE pattern that was just matched. This means that the BEGIN statement that this pattern matches must be located inside of the WHILE Val <> 99999 DO ... statement. Therefore, there is only one BEGIN statement that has an appropriate match.

When PROUST tries to match the (SUBGOAL (Input ?New)) components, a different type of processing is required. These plan components are goals; to match them against the program, PROUST must go through the same plan-selection

(continued)

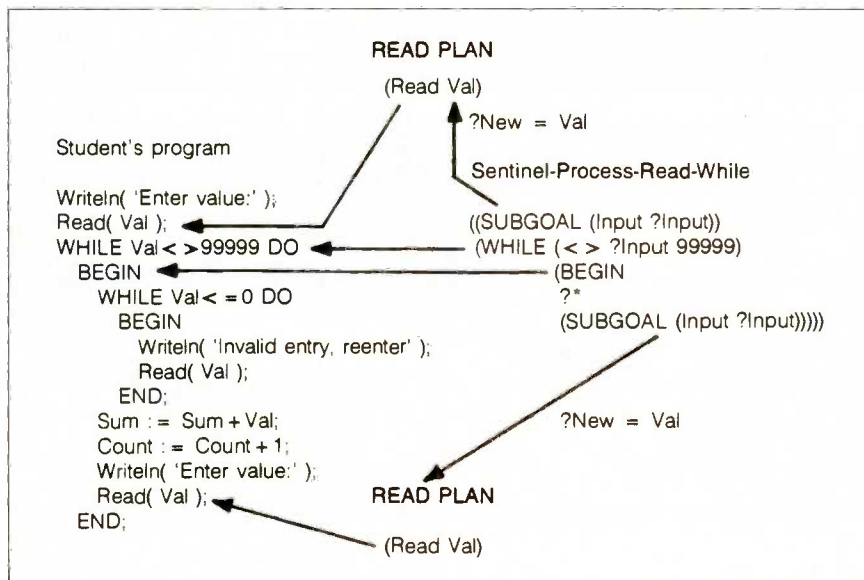

Figure 6: This shows how the Sentinel-Process-Read-While plan is matched against the program in figure 1.



# GenTech

## COMPUTERS

### IBM SYSTEM SPECIALS

256K, 2 Drives	\$Call
256K, 2 Drives, color graphics, printer adaptor & PGS HX-12 monitor	\$2499
256K, 1 Drive & 10 MB Hard Disk	\$Call
<b>TWO USER SYSTEM</b> (incl. 10 MB, Advanced Digital PC Bd & Terminal)	\$3859



<b>COLUMBIA</b>	
MPC 4220 (256K, 2 Drives)	\$1899
PROFESSIONAL (10MB, w/tape backup)	\$Call
VP 2220 (Portable w/256K)	\$1899
<b>COMPUPRO 10</b> (10 MB, Multi-user)	\$Call

<b>CORONA PC-22</b> (256K, 2 Drives)	\$Call
Portable PC-22 (256K, MS-DOS 2.0)	\$Call
FUJITSU MICRO 16s (8086/Z80A)	\$1995
<b>MORROW DESIGNS</b> Phot. MD2, MD3 MD5, MD11	\$Call

<b>NEC APC-III PACKAGES</b>	
APC-III w/2 Dr, Wordstar Pro Pk, 2050 printer above with 3550 printer	\$2299
APC-III w/384K, Multiplan, BPS Graphics and P313 Pinwriter (15" carriage)	\$2799
APC-III w/1 Dr, 10 MB Hard Disk, Mono CRT above with Color CRT	\$2159
APC-III w/1 Dr, 10 MB Hard Disk, Mono CRT above with Color CRT	\$2379

<b>SANYO</b>	
MBC 555-2 (8088, 2 DSDD, software)	\$1099
MBC 555-2 (550-2 Plus 1 Add Drive Mailmerge, Spellstar & Infostar)	\$Call
SEEQUA Chameleon/Plus (8088/Z80)	\$Call
<b>SWP Micro Computer Products</b>	
Co-Power-88 Board (8088 w/256K, 1 MB) For KAYPRO 2, 4 & 10	\$Call

<b>TELEVIDEO</b>	
1605/PC-II (8088, 256K)	\$Call
<b>LEADING EDGE PC</b>	\$Call
ZENITH Z-151-52 (8088, 2 Dr, 320K RAM)	\$Call
ZW 151-52 (1 Dr, 10 MB Hard Disk)	\$Call

### FOR IBM PC/XT/AT & COMPAQ

<b>ADVANCED DIGITAL</b> Multi User Bd (8086)	\$Call
<b>AST RESEARCH INC.</b>	
ADVANTAGE II (Multi Ftn Bd for AT)	\$Call
MEGA PLUS II (64K, Ser & Clik)	\$279
Six Pack Plus (64K, Ser/Par/Clik)	\$249
MONO GRAPH PLUS Card	\$Call

<b>QUADRAM</b>	
EXPANDED QUADBOARD (S. P. Clock, Game) 64K	\$249 384K \$429
QUAD 512+ (Serial Port, Maximum 512K) 64K	\$229 256K \$349
QUADCOLOR I (Video Board)	\$199

<b>HERCULES</b> Graphics Board (720x384)	\$339
Color Card (RGB, Composite, Parallel)	\$169
<b>NTEL 8087/80287</b> Math Co-Processor	\$Call
<b>EYTRONIC</b> Deluxe IBM Keyboard (5151)	\$199
<b>4 SYSTEMS</b> PC Peacock (RGB & Composite, Parallel Port)	\$209

<b>ROLOG</b> Baby Blue II (Z80B, 64K, Parallel & Serial Ports, Clock/Calendar)	\$529
<b>110 PC Turbo</b> (80186 CPU, 8 MHz)	\$Call
<b>SONIC JA 551-2</b> (DSDD Thinline Drive)	\$119
<b>ISE SYSTEMS</b> Multi-Display Card	\$295
r Graphics Card	\$279

ule A/B	\$Call
<b>ONICS</b> ColorPlus	\$Call
<b>TEMS</b> Graphix Plus II	\$319
Rio w/64K	\$289
'M 100-2 (DSDD Disk Drive)	\$149
5B (DSDD Thinline Drive)	\$125
raphics Master (640x400 RGB)	\$489
ain (w/ OK)	\$239
w/128K, parallel port]	\$309
Ultra Pak	\$489

## HARD DISK

**APPLE MACINTOSH HARD DISKS NOW AVAILABLE! CORVUS, DAVONG & TECMAR... CALL FOR PRICES!**

<b>AMPEX 20 MB W/25 MB Tape Back-Up</b>	\$Call
<b>MICROSCIENCE</b> Internal 10 MB System for IBM	\$679
<b>CORVUS</b>	
OmniDrive (11 MB)	\$Call
Transporter	\$399 The Bank \$1779
<b>DATAMAC</b> Truster 10	\$1129



<b>DAVONG</b>	
DataSystem w/24 MB Tape Back-Up	\$Call
<b>OMEGA</b> Bernoulli Box/Bernoulli Plus	\$Call
<b>MAYNARD ELECTRONICS</b> 10/20/30 MB	\$Call
<b>PEGASUS-GREAT LAKES</b>	
10 MB Internal For IBM	\$959
23 MB External (w/ Controller)	\$Call
<b>SYSGEN</b>	
10/20 MB w/Tape Back-Up	\$2295/\$2849
Image/Dic-File	\$799/\$1199
<b>TALLGRASS</b>	
TG-5025 (25 MB w/60 MB Tape Back-Up)	\$2899
TG-6180 (80 MB w/60 MB Tape Back-Up)	\$6399
<b>TECMAR</b>	
Remov. Cartridge Winchester in PC (5 MB)	\$1479
10 MB W5 MB Cartridge in Chassis	\$2459
<b>XCOMP</b> 16 MB External (For IBM, Apple, Kaypro & Morrow Designs)	\$1749

## DOT MATRIX PRINTERS

<b>C-I TOH</b> Prowriter 1 8510 AP	\$329
Prowriter 2 1550 P (15", 120 cps)	\$569
<b>EPSON</b> JX-80: Color Printer	\$585
LQ-1500	\$1109 RX-100 \$Call
RX-80/80 FIT	\$Call FX-80/100 \$Call



<b>CITIZEN</b>	
MSP-10	\$355 MSP-15 \$559
MSP-20	\$475 MSP-25 \$669
<b>MPI</b> Sprinter/SX (Portable, 300 cps)	\$Call
<b>NEC</b>	
P2/P3 Pinwriter (180 cps)	\$525/\$735
P2/P3 Color Pinwriters	\$Call

<b>OKIDATA</b>	
Ask for <b>NEW Apple Imagerwriter Compatible</b>	
ML 92	\$Call ML 93 \$Call
ML 84(P)	\$Call Pacemark \$Call
<b>PANASONIC</b> KX-P1091/1093	\$299/\$Call
<b>STAR MICRONICS</b>	
Gemini 10X	\$249 Gemini 15X \$349
SD-10/15	\$Call SG-10/15 \$Call
<b>TEXAS INSTRUMENTS</b>	
850/855/860/865	\$Call
<b>TOSHIBA</b>	
P1340	\$719 P1351 \$1289

## LETTER QUALITY PRINTERS

<b>ABATI</b> LQ-20 (18 CPS, 15" Carriage)	\$359
<b>AMDEK</b> 5040 (40 CPS)	\$1299
<b>BROTHER/DYNAX</b>	
HR-15XL (20 cps, Diablo compat.)	\$369
HR-25/HR-35	\$Call/\$869
<b>HEWLETT PACKARD</b> Laser Printer	\$Call
<b>DIABLO</b>	
620 API	\$779 630 ECS/IBM \$1779
<b>JUKI</b> 6100 (17 CPS, Diablo Compat.)	\$Call
6300 (40 CPS, Diablo Compat., 3K Buf.)	\$Call
<b>NEC</b>	
ELF	\$Call 2030 \$659
3550	\$Call 8850 \$1879
<b>OLYMPIA</b> Compact RO2	\$349/\$419
<b>QUADRAM</b> Quadjet (Ink Jet Printer)	\$759
<b>DUME</b> Sprint 1140/1155	\$1299/\$1479
Letterpro 20	\$Call
<b>SILVER-REED</b> EXP 500 (parallel or serial)	\$369
EXP 550 (p or s, 15" carriage)	\$449
<b>STAR MICRONICS</b> Power Type (18 CPS)	\$339
<b>TRANSTAR</b> T120/T130	\$409/\$569

## PLOTTERS

<b>NEW!! POLAROID PALETTE!!</b>	\$Call
<b>AMDEK</b> DXY-100/Amplot II	\$599/\$749
<b>ENTER COMPUTERS</b>	
Sweet-P	\$Call Six-Shooter \$785
<b>HOUSTON INSTRUMENTS</b>	
PC-595/PC-695 New!!!	\$Call
DMP-40-2	\$749 DMP-29 \$1799
DMP-41/42	\$2349 DMP-51/52 \$3529
DT-11 Digitizer (1-Button Cursor)	\$679
DT-114 Digitizer (4-Button Cursor)	\$739
<b>PANASONIC</b> VP-6801A	\$1449
<b>ROLAND</b> DXY-101/800/880	\$529/699/949
<b>STROBE</b> Model 200/Model 260	\$519/\$729

## MONITORS

<b>AMDEK</b>	
Video 300/300A/310A	\$135/145/165
Color 300	\$249 Color 500 \$379
Color 600	\$429 Color 710 \$579
<b>DYNAX</b> Fortis FC10 (13" RGB)	\$Call
<b>MONITECH</b> 12" Green/Amber	\$80
<b>PRINCETON GRAPHICS</b> HX-12	\$469
SR-12 (690x480)	\$609
Max-12 (12" Amber, TTL)	\$179
<b>QUADRAM</b> Amberchrome	\$155
Quadchrome II	\$435
<b>ROLAND</b>	
MB-121G	\$135 MB-122G \$155
CB-141	\$269 CC-141 \$559



<b>TAXAN</b>	
Model 115	\$119 Model 116 \$129
210 (380x262)	\$259 420 (640x262) \$439
<b>ZENITH</b>	
ZVM-123A	\$79 ZVM-122A \$85
ZVM-135	\$439 ZVM-136 \$Call

## TERMINALS

<b>ESPRIT</b>	
Esprit I	\$Call Esprit II \$479
Esprit III	\$Call ESP-6310 \$559
<b>QUME</b> 1027/102A	\$469/\$489
103/108 (Green)	\$849/\$519
<b>TELEVIDEO</b> 914/924	\$519/\$675
950/970	\$Call
Personal Terminal	\$419
w/ 300 Baud Modem	\$528



<b>VISUAL</b> 50/55/60	\$559/\$689/Call
102/300	\$Call
<b>WYSE</b>	
WY-50	\$519 WY-75 \$609
WY-100	\$Call WY-300 \$819
<b>ZENITH</b>	
Z-29	\$649 Z-49 \$Call
ZTX-10	\$329 ZTX-11 \$389

## COMMUNICATIONS FOR IBM

<b>BLUE LYNX</b> 3278	\$Call
<b>OCA</b> Irma/IrmaLine/IrmaKey	\$Call
<b>IDEAcomm</b> 3278	\$Call
<b>ANCHOR</b>	
Mark VI	\$179 Mark XII \$249
<b>HAYES</b>	
Smartmodem 300/1200	\$199/\$Call
Smartmodem 1200B w/SmartCom II	\$399
<b>NOVATION</b>	
Smart Cat Plus 300/1200 w/Mite	\$329
<b>PRENTICE</b> POPCOM C100/X100	\$289/\$299
<b>PROMETHEUS</b> Promodem 1200	\$Call
<b>QUADRAM</b> Quadmodem	\$Call
<b>TRANSEND</b> PC Modem Card 1200	\$419
<b>VEN-TEL</b> 300/1200 Half Card	\$409

## SOFTWARE

<b>ASHTON-TATE</b> dBase III/Framework	\$Call
<b>PRENTICE HALL</b> VCN ExecuVision	\$Call
<b>REAL WORLD</b> MBSI Accounting	\$Call
<b>LOTUS</b> 1-2-3/Symphony	\$319/\$429
<b>MICROPRO</b> WordStar 2000/Pro pack	\$Call
<b>MICROIM</b> R-Base 4000/Clout	\$285/\$Call
<b>DEC.RESOURCES</b> Charu/Sigmaster	\$239/\$185
<b>SAMNA</b> Word III	\$375
<b>SATELLITE SOFTWARE</b> Word-Perfect	\$Call
<b>AUTOCAD</b> Autocad	\$Call
<b>CENTRAL POINT</b> Copy II PC/PLUS	\$29

## FOR APPLE II/IIe

<b>ALS</b> CPM Plus Card	\$299
Smarterm II (80 Column Card)	\$129
<b>AST RESEARCH INC.</b> Multi I/O Card	\$Call
<b>DIGITAL RESEARCH</b> CPM Gold Card w/64K	\$269
<b>FOURTH DIMENSION</b> 16K RAM Card	\$55
80-Column Card	\$55
<b>HAYES</b>	
Micromodem IIe w/SmartCom I	\$239
Smartmodem 300/1200	\$199/\$Call
<b>INTERACT. STRU.</b> PKASO Universal	\$125
<b>MICROSOFT</b> Premium Softcard (IIe)	\$Call
Softcard II (for II/IIe)	\$339
<b>MICROTEK</b> Dumping-GX	\$69
<b>NOVATION</b>	
J-Cat (Auto Orig/Answer, 300 Baud)	\$99
Apple Cat II (300 Baud)	\$209
212 Apple Cat II (1200 Baud)	\$389
103/212 Smart Cat (1200 Baud)	\$389
<b>ORANGE MICRO</b> Grappler+	\$109
Buffered Grappler+ (16K)	\$169
Grappler Interface for ImageWriter	\$Call
<b>PCPI</b> Applicard 6 MHZ	\$249
<b>RANA</b> Elite I/II/III	\$Call
<b>TRANSEND</b> ASIO	\$125
Modemcard w/Source	\$239

## MISCELLANEOUS

<b>RAM CHIPS</b>	
64K SET	\$Call 256K SET \$Call
<b>DOUBLE-SIDED</b> DISKETTES	
<b>WABASH</b> DataTech	\$20
3M	\$30 Dysan \$31
Maxell	\$30 Verbatim \$30
<b>PRINT BUFFERS</b>	
<b>QUADRAM</b> Microfazer	
Parallel/Parallel	
16K	\$139 64K \$185 128K \$239
Serial/Serial, Serial/Parl, Parl/Serial	
8K	\$145 16K \$155 64K \$209
<b>INTERACTIVE</b> STRUCT. ShuffleBuffer 32K	\$269
<b>PRACTICAL PERIPHERALS</b> Microbuffer 32K	\$209
<b>SWITCHBOXES</b>	
<b>CABLECO</b> 3 Way Centronics	\$Call
3 Way Serial	\$Call
<b>COMPUTER ACCESSORIES</b>	
Data Directors (All Models)	\$Call
<b>SURGE PROTECTORS</b>	
EPD/CURTIS All models	\$Call
<b>NETWORK</b> Wire Tree/Wire Tree Plus	\$45/\$60
ULTIMA SF-600	\$39
<b>EMERGENCY POWER SYSTEMS</b>	
TrippLite BC200-10 (battery incl)	\$270
TrippLite BC425-FC (425 Watts)	\$415
SOLA ELECTRIC Mini UPS	\$Call

## CUSTOMER SERVICE

**401-781-0020**

**800-843-4302**

150 Broadway, Suite 2212, N.Y., NY 10038

**HOURS** 9-8 EST/MON-SAT  
Money Order, Cashier's Chk, Personal Chk (2 Weeks To Clear).  
APO Orders Add 6% (minimum \$7). Add 3% For Net Terms.  
All Returned Non-Defective Merchandise Are Subject To  
20% Restocking Charge.  
GenTech Reserves the Right to Change Advertised Prices.



Inquiry 164





**The Silver Fox™ Trots through Lotus like 1,2,3**

The Silver Fox has always run hundreds of programs originally written for the IBM-PC. Now with its new compatible video board and GW Basic it runs the most popular and powerful software in microcomputing, including Lotus 1,2,3, dBASE II, Multiplan, the PFS series, and even Flight Simulator. Yet you still get an incomparable combination of hardware and software at a price that invites comparison.

**MORE HARDWARE**

Each Silver Fox comes with an 8088 CPU, 256K of RAM, monochrome and color video, and a printer port all on a single board. Plus you get more than twice the storage of a standard PC, 1.6 Megabytes on dual 5 1/4" floppies, and the Fox will read and write to all popular PC formats.

Standard equipment also includes a better keyboard, and a 12" high-resolution, green monochrome monitor, with a full 25x80 column display. And although the Silver Fox doesn't have "compatible" expansion slots you can add serial ports, modems, plotters, printers, joysticks, and 8087 co-processor, and/or a hard disk.

Because the Silver Fox is born on a totally automated line in Japan it is simply more reliable than PC's that are assembled by hand. So we back each Silver Fox with a one year limited warranty, four times the industry standard.

**FREE SILVERWARE**

Were this not enough, each Silver Fox comes with the best free software bundle in the business including:

- |             |                  |             |
|-------------|------------------|-------------|
| MS-DOS 2.11 | Wordstar 3.3     | FILEBASE    |
| HAGEN-DOS   | Easy Writer      | PC File III |
| Color BASIC | Mail Truck       | PD Disk     |
| GW BASIC    | Spell            | Datamate    |
| OS Tutor    | Games & Graphics | CalcStar    |

If you didn't think your  
**\$1397**

could buy you this much computer,  
call our machine at

**1-800-FORAFox**

leave your name and address at the beep and we'll rush you a brochure that will tell you how it can. To order call

**(602) 941-5856.**

ColorFox ..... **\$1647**

The Silver Fox is sold exclusively by Scottsdale Systems Ltd., 617 N. Scottsdale Road #B, Scottsdale, AZ 85267. Trademarks: Silver Fox, HAGEN-DOS, Qwikdisc, Datamate, and Mailit, Scottsdale Systems Ltd, WordStar and CalcStar, Micropro International, MS-DOS, Multiplan, Microsoft Corporation, FILEBASE, EWDF Software, Inc, dBASE II, Ashton-Tate, IBM-PC, International Business Machines Corporation. Ordering: Telemarketing only. Silver Fox price is for cash, F.O.B. Scottsdale, prices subject to change, product subject to limited supply. We accept purchase orders from Fortune 1000 companies and major universities with good credit - add 2%. Visa, Mastercard add 3%, AZ residents add 6%. Returned merchandise subject to a 20% restocking fee. Personal or company checks take up to 3 weeks to clear. No COD's or APO's.

*Since PROUST first generates a possible implementation and then matches it against the program, it is performing analysis by synthesis.*

process that it went through in selecting the Sentinel-Process-Read-While plan. It first substitutes all pattern variables in the goal expression that have bindings. Since ?New has Val as a binding, the subgoal expression becomes (Input Val). PROUST then retrieves plans from the plan database that implements Input. One such plan is the READ PLAN, which employs a Pascal Read statement to input the value. This plan matches the Read statements in the program.

This example shows how PROUST analyzes programs by predicting the plans that might be used and then testing these predictions. By selecting from a range of different plans and subplans for each goal, PROUST is able to generate a variety of different ways of implementing each goal. Since PROUST first generates a possible implementation and then matches it against the program, it is performing analysis by synthesis. In general, generating plan hypotheses and matching them against programs is rather more complex than the scenario presented here; for more information, see reference 3.

**IDENTIFYING BUGS**

When the Sentinel-Process-Read-While plan was matched against the program in figure 1a, the plan matched exactly. Since there were no match errors, there must not have been any bugs in that particular plan. It is frequently the case, however, that none of the plans that PROUST

predicts matches the program. When this happens PROUST must look for bugs that account for the mismatches in one of the plans. In this section we will discuss one of these mismatches in connection with the WHILE-for-IF example in figure 2a and show how it leads to the discovery of a bug.

The bug in the WHILE-for-IF example is discovered in processing the Input-Validation goal. One of the plans that PROUST suggests for implementing this goal is the so-called Bad Input Loop Test plan. This plan consists of a WHILE statement that tests the input to see if it is out of range, an error message inside the WHILE loop, an Input subgoal that rereads the input if it is out of range, and a test to see if the exit condition for the main loop has been satisfied.

Listing 2 illustrates a correct implementation of this plan (solving the Averaging Problem).

The Bad Input Loop Test plan matches the WHILE-for-IF example of figure 2a in all but one respect: there is no test for the exit condition of the main loop, such as IF Val < > 99999 THEN . . . . Where an IF statement is expected, a WHILE statement appears instead. PROUST has thus encountered a *plan difference*, i.e., a difference between the expected plan and the code. When PROUST encounters plan differences it does not give up on the plan; instead, it tries to find a way of interpreting the plan differences as bugs.

In most cases plan differences are explained by means of *bug rules*. Each bug rule has a test part, which examines the plan differences to see whether the rule is applicable, and an action part, which explains the plan differences.

Figure 7 shows the bug rule that is invoked to explain the plan differences in the WHILE-for-IF example. The rule is written in slot-filler notation; one set of slots constitutes the test part of the rule, and another set constitutes the action part. In the WHILE-for-IF rule the test part consists of a Statement-Type slot and an Error-Pattern slot. The Statement-Type slot indicates that the plan com-



ponent that failed to match the program must be an IF statement. The Error-Pattern slot has the value (IF . WHILE); this indicates that a WHILE statement was found when an IF statement was expected. These test conditions are both met in the WHILE-for-IF example, so the action part of the rule is activated. The action part of this rule consists of a Bug slot; the filler of this slot is a description of the bug associated with the plan difference. The bug in this case is a WHILE-for-IF confusion. PROUST's bug analyses of student programs consist of bug descriptions such as this. When PROUST presents its findings to the student, it takes each bug description and generates an English-language translation for it and, if appropriate, generates data illustrating the presence of the bug.

**TEST RESULTS**

PROUST has been tested on large numbers of beginners' programs. We assigned a class of novice programmers the Rainfall Problem (an elaboration of the Averaging Problem), which is shown in figure 8a.

We modified the Pascal compiler our students were using so that it would save copies of every syntactically correct program that they compiled. This allowed us to examine not only the final solution the students handed in, but also every intermediate version of their program. Since the first versions are likely to be the 'buggiest', this let us test PROUST under the most difficult conditions possible.

Figure 8b shows the results of running PROUST on the Rainfall Problem. There are 206 different attempted solutions to the Rainfall Problem in the test set. Of these, PROUST was able to derive a complete understanding of 79 percent of the programs, identifying 94 percent of the bugs, a percentage far higher than people are able to achieve. The chart also indicates that 6 percent of the bugs were not recognized and 55 were false alarms. Bugs are counted as not recognized if they are either misdiag-

(continued)

Listing 2: A correct implementation of the Bad Input Test plan.

```
WHILE Val <= 0 DO
  BEGIN
    WriteIn( 'Invalid data, please reenter' );
    Read( Val );
  END;
IF Val < > 99999 THEN
  ...
```

```
(Define-Rule WHILE-for-IF
  Statement-Type IF
  Error-Pattern (IF . WHILE)
  Bug (WHILE-for-IF Confusion (FoundStmt ;*MRet*)
      (HistInst ;*HistoryNode*))
```

Figure 7: The WHILE-for-IF bug rule invoked by PROUST to explain the plan difference between the faulty part of the program of figure 1 and the correct implementation of this part in listing 1.

(a)

Write a Pascal program that will prompt the user to input numbers from the terminal; each input stands for the amount of rainfall in New Haven for a day. Note: Since rainfall cannot be negative, the program should reject negative input. Your program should compute the following statistics from this data:

1. the average rainfall per day
2. the number of rainy days
3. the number of valid inputs (excluding any invalid data that might have been read in)
4. the maximum amount of rain that fell on any one day

The program should read data until the user types 99999; this is a sentinel value signaling the end of input. Do not include the 99999 in the calculations. Assume that if the input value is nonnegative, and not equal to 99999, then it is valid input data.

(b)

Total number of programs:	206	
Number of programs with bugs:	183	(89 percent)
Number of programs receiving full analyses:	161	(79 percent)
Total number of bugs:	570	
Bugs recognized correctly:	533	(94 percent)
Bugs not recognized:	29	(6 percent)
False alarms:	55	
Number of programs receiving partial analyses:	35	(17 percent)
Total number of bugs:	191	
Bugs recognized correctly:	71	(37 percent)
Bugs deleted from analysis:	70	(37 percent)
Bugs not recognized:	50	(26 percent)
False alarms:	19	
Number of programs PROUST did not analyze:	9	(4 percent)

Figure 8: (a) The Rainfall Problem was assigned to a class of novice programmers to test the effectiveness of PROUST. (b) This shows the results of running PROUST on the Rainfall Problem.



# Mac Inker

Re-ink any fabric ribbon **AUTOMATICALLY** for less than 5¢. Extremely simple operation with built-in electric motor. We have a MAC INKER for any printer: cartridge/spool/harmonica/zip pack. Lubricant ink safe for dot matrix printheads. Multicolored inks, uninked cartridges available. Ask for brochure. Thousands of satisfied customers.

\$54.<sup>95</sup> +



# Mac Switch

Mac Switch lets you share your computer with any two peripherals (serial or parallel). Ideal for word processors—never type an address twice. Ask us for brochure with tips on how to share two peripherals (or two computers) with MAC SWITCH. Total satisfaction or full refund.

\$99.<sup>00</sup>

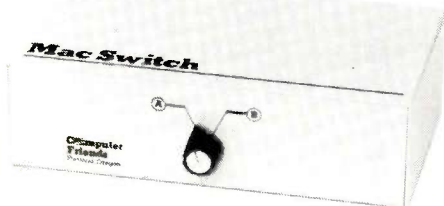

Order toll free 1-800-547-3303

## Computer Friends

6415 SW Canyon Court  
Suite #10  
Portland, Oregon 97221  
(503) 297-2321

## PROUST

### *Ultimately, PROUST will be incorporated into a programming curriculum for students.*

nosed or missed entirely. Bugs are counted as false alarms if they are either not present in the program or if they are present but misdiagnosed. Consequently, misdiagnosed bugs are counted both as false alarms and as not recognized, which inflates the total number of diagnosis errors.

When PROUST fails to understand a program completely, its ability to recognize bugs deteriorates; 17 percent of the programs were analyzed partially. In such cases PROUST deleted from its bug descriptions those bug analyses that were questionable, given that the program was only partially understood. The bug descriptions that remained were frequently wrong, but at least PROUST was able to warn the student to take the analysis with a grain of salt. The remaining 4 percent of the programs deviated from PROUST's expectations so drastically it could not analyze them at all. In these cases no bug report was generated.

We are not yet sufficiently satisfied with PROUST's accuracy to make it generally available to students. The false-alarm rate should be lower, and the fraction of programs that PROUST analyzes completely should be higher. When part of a program cannot be analyzed, PROUST should try to determine why that part of the program cannot be analyzed and try to account for the unanalyzed code. Once this is done we expect PROUST to succeed on 80 to 85 percent of the programs it analyzes. At that stage we will make it available to students on line.

### CONCLUSION

PROUST is capable of high-quality analysis of bugs in novice programs.

It is almost at the level where it could be incorporated into a programming curriculum and provide significant benefits to students. Here we have given a simplified view of how PROUST finds bugs. The next step is to build an automated programming course around PROUST. Such a system would not only correct students' mistakes but would also suggest additional problems for the students to solve to give them practice where they need it. ■

### AUTHORS' NOTE

This work was cosponsored by the Personnel and Training Research Groups, Psychological Sciences Division, Office of Naval Research, and the Army Research Institute for the Behavioral and Social Sciences, under Contract Number N00014-82-K-0714, Contract Authority Identification Number Nr 154-492.

Additional papers dealing with bug classification, automatic debugging, and the cognitive underpinnings of programming can be obtained by writing to the following address: Cognition and Programming Project, Department of Computer Science, Yale University, POB 2158 Yale Station, New Haven, CT 06520.

Special thanks to Greg Kearsley and Leszek Izdebski of Courseware Inc. and Bret Wallach of Advanced Processing for their efforts in developing Micro-PROUST.

### REFERENCES

1. Fosdick, L. D., and L. J. Osterweil. "Data Flow Analysis in Software Reliability." *Computing Surveys* 8, vol. 3, 1976, pages 305-330.
2. Harandi, M. T. "Knowledge-Based Program Debugging: A Heuristic Model." Proceedings of the 1983 SOFTFAIR.
3. Wertz, H. "Stereotyped Program Debugging: An Aid for Novice Programmers." *International Journal of Man-Machine Studies* 16, 1982, pages 379-392.
4. Shortliffe, E. H. *Computer-Based Medical Consultations: MYCIN*. New York: American Elsevier Publishing Co., 1976.
5. Minsky, M. "A Framework for Representing Knowledge." *The Psychology of Computer Vision*, P. Winston, ed. New York: McGraw-Hill, 1975.
6. Johnson, W. L. "Intention-Based Diagnosis of Programming Errors." Yale University Department of Computer Science, 1984.





## Double your IBM PC's processing speed for under \$650.

### AT speed for your IBM PC, with QuadSprint by Quadram.

Quadram introduces a rapid advancement in IBM PC performance. QuadSprint. The innovative expansion board that doubles the processing speed of your personal computer. Just plug the totally transparent QuadSprint into your system and watch **all** your PC programs (Lotus 1-2-3, dBASE III, Wordstar, and more\*) run faster and more efficiently than ever before... without special commands or interface software.

But best of all, you can pick up QuadSprint without running up a huge bill. At less than \$650, QuadSprint is about half the price of other accelerator (turbo) cards and turns your PC into a machine that's virtually as fast as the new PC AT.

So make your own rapid advancement. To the Quadram dealer closest to you. And see how to double the processing speed of your IBM PC. With QuadSprint by Quadram.

## QUADSPRINT™

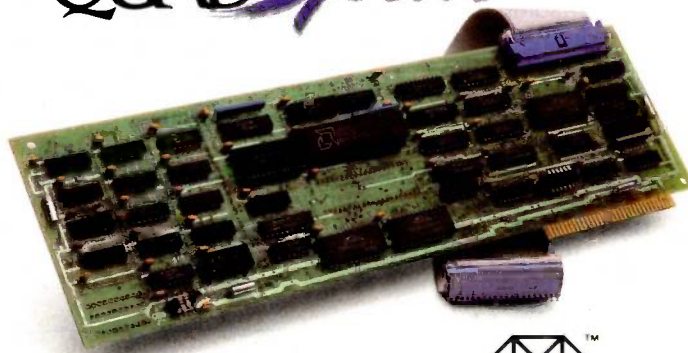

**QUADRAM**   
An Intelligent Systems Company

4355 International Blvd./Norcross, Ga. 30093  
(404) 923-6666/TWX 810-766-4915 (QUADRAM NCRS)

Inquiry 323



# 100 MHz scope, counter, timer, multimeter: All one integrated system.

**100 MHz dual time base scope.** 3.5 ns risetime; sweeps from 0.5 s to 5 ns/div; alternate sweep;  $\pm 2\%$  vertical/horizontal accuracy; vertical sensitivity to 2 mV/div @ 90 MHz.

**9-digit fluorescent display.** Digitally accurate readouts accompany the CRT waveform. Error messages and prompts also appear on the display.

**Dc volts and ac coupled true RMS volts.** Measured through the Ch 1 scope input.

**Gated measurements.** Use the scope's intensified marker to measure frequency, period, width and to count events within specified portions of the signal.

**Auto-ranged, auto-averaged counter/timer.** Frequency, period, width, delay time,  $\Delta$ -time, plus totalize to more than 8 million events—with 7 digits plus exponent displayed.

**Auto-ranged DMM.** Use floating DMM side inputs with up to 5000-count resolution. Get precise readouts of average dc and true RMS voltage. Measure resistance from milliohms to gigohms.

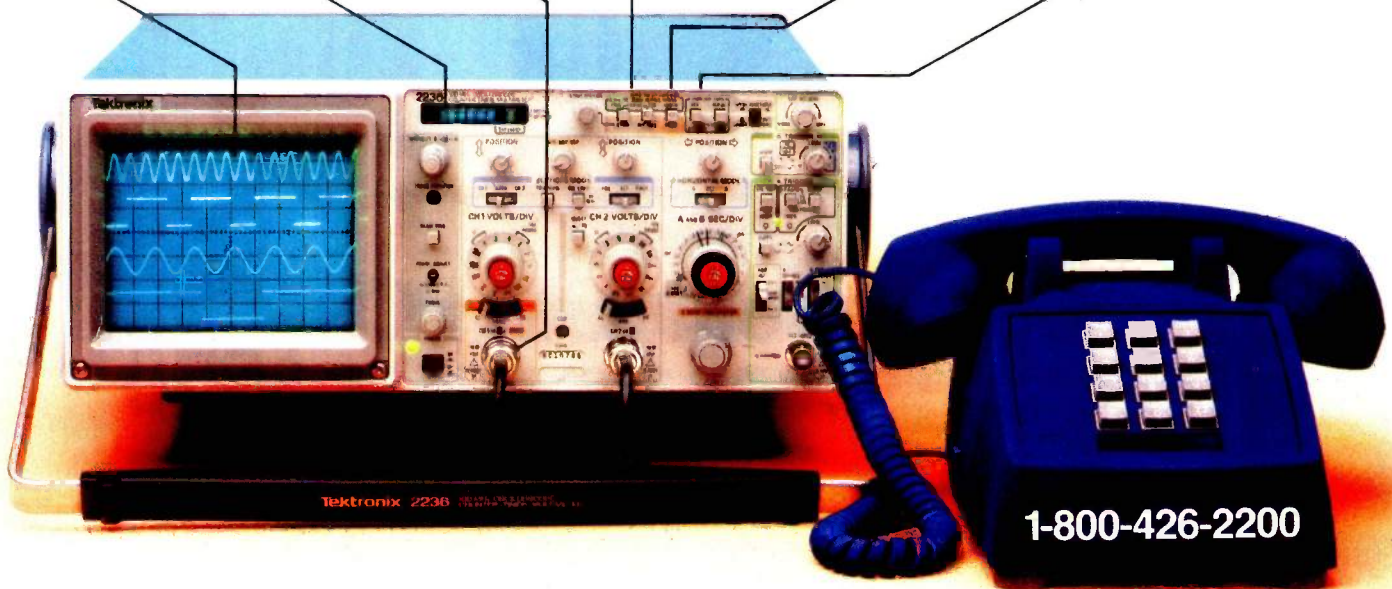

**Now make measurements faster, easier, with greater accuracy and user confidence.** The Tek 2236 makes gated counter measurements, temperature, time, frequency, resistance and voltage measurements push-button easy. You see results concurrently on the 9-digit numeric readout and CRT display.

Its complete trigger system includes pushbutton trigger view, plus peak-to-peak auto, TV line, TV field, single sweep and normal modes.

At just \$2650\*, the 2236 includes the industry's first 3-year warranty on all parts and labor, including the CRT.

**Integrated measurement system. 3-year warranty. 15-day return policy. And expert advice. One free call gets it all!** You can order, or obtain literature, through the Tek National Marketing Center. Technical personnel, expert in scope applications, can answer your questions and expedite delivery. Direct orders include probes, operating

manual, 15-day return policy, full warranty and worldwide service back-up.

**Order toll-free:  
1-800-426-2200  
Extension 57**

In Oregon call collect:  
(503) 627-9000 Ext. 57  
Or write Tektronix, Inc.  
P.O. Box 1700  
Beaverton, OR 97075

**Tektronix®**  
COMMITTED TO EXCELLENCE



# ARCHITECTURES FOR AI

BY MICHAEL F. DEERING

## *Hardware and software for efficient processing*

AS ARTIFICIAL-INTELLIGENCE software grows in complexity and as AI applications move from laboratories to the real world, computational throughput and cost are increasingly important concerns.

In general, there are two motives for increasing the efficiency of computations. One is the need to obtain faster computation, regardless of cost. This may be due to explicit real-time constraints or to current methods being taxed well beyond the limit of complexity or timely response. The other motive seeks to obtain a better cost/performance ratio. Behind both, however, is usually the imperative of real-world market pressures.

Opportunities for increased efficiency in AI computations exist at every level. Improved instruction-set designs combined with improved AI language semantics allow more powerful compiler optimization. Concurrent machines allow parallel execution of LISP and declarative constructs, raising issues of *and*, *or*, and *stream parallelism*. Custom VLSI (very-large-scale integration) hardware for current AI performance bottlenecks includes devices such as hardware unifiers, associative memory, and communication hard-

ware for coordinating parallel searches. Many of these speedups are orthogonal and can potentially increase performance by several orders of magnitude. However, this is not always the case; some language optimizations have a tendency to serialize computation, thereby negating the gains of parallelism.

As part of an effort to design a massively concurrent architecture for AI computation (the Fairchild FAIM-1 project—see the text box on page 202), this article examines several potential throughput increases and their interactions.

### **MISCONCEPTIONS**

There are several misconceptions about what needs to be done to improve computational throughput for AI. Since most AI programming is done in LISP, many researchers believe the key is simply to make LISP faster. However, this approach ignores other, easily obtainable potential speedups.

Other computer scientists see no reason to concentrate on anything other than the fundamental problem of parallelism, an approach that presumes a routine solution of a very

difficult problem: decomposing arbitrary AI computations to effectively use thousands of parallel processors. A problem with this approach is that most programs, even ones with a high degree of inherent parallelism, almost always have several serial bottlenecks. As an example, most parallel programs need to gather the result of one batch of parallel computations for reflection before generating the next batch. In many cases, these serial processes dominate the running time of the entire program. So you cannot ignore the issue of how to extract as much serial speed as possible from languages and machines. Otherwise, once you've built an expensive parallel machine hundreds of times faster than existing machines, a new compiler or microcode might make some existing serial machines even faster. The machine coded unifier in the Crystal AI language, for instance, is two orders of magnitude faster than the LISP-coded unifier in the pre-

(continued)

*Michael F. Deering is a computer scientist with the Computer-Aided Systems Laboratory. He can be reached through Schlumberger Palo Alto Research, 3340 Hillview Ave., Palo Alto, CA 94304.*



decessor PEARL AI language (see reference 3).

**SOFTWARE IMPROVEMENTS**

One way to improve AI language implementations would be to compile the language directly to machine code. Most AI "languages" are not computer languages but packages of routines on top of an existing language, usually LISP. While this is a great way of rapidly prototyping a language and results in considerable savings in development costs over a traditional full compiler, it does not lead to very efficient implementations. If increasing the speed of AI applications leads to the extreme of building custom parallel processors, it is silly not to compile AI languages directly onto these processors. There is a large body of computer science knowledge on compilation that can be brought to bear, and great potential for performance increases. (Consider the 100-times plus speed difference between most LISP-based Prolog interpreters and Warren's DEC-20 Prolog compiler—see reference 17.)

Make sure that the language is compilable. Because most AI languages have been interpreted, issues of compilability generally have not been thought through. Language features that seemed efficient in an interpreted environment may be very slow when compiled, if they are compilable at all.

A proper choice of features in light of a compiled environment leads to more efficient program execution.

Another problem with many AI languages is the lack of general tools to support common applications. While it can be argued that this allows users to write their own customized tools (which may be very efficient), most users will do a much worse job than the language implementor could. For example, PEARL did not directly support any particular theorem-proving or search system (such as forward and backward chaining), leaving users to their own devices. But the MRS system (reference 11), while providing a convenient meta-level control for users to write their own search systems, also provides a range of built-in search strategies, from backward chaining to full-resolution theorem proving. An extensive library of well-written routines of general use speeds the operation of typical user programs (not to mention their development).

**HARDWARE CONSIDERATIONS**

It is often claimed that conventional computer instruction sets are not well suited for AI software, but there have been few attempts to quantify the reasons why. For older-generation machines, you can easily point to severe address-space limitations and the lack of flexible pointer-

manipulation facilities (reference 6). But what of the new, modern machines, such as the DEC VAX, Motorola 68000, National Semiconductor 16000, and various RISC (reduced instruction set computer) machines—how do they compare with the custom LISP machines (references 13 and 15)? To obtain insights into instruction-set design, I examined several LISP systems and the fine details of their implementation (reference 5). I learned, among other things, that it is very important to identify how rich an environment you wish to support. For example, contrary to many people's expectations, on a large application program Franz LISP (reference 8) on a DEC VAX-11/780 was not significantly slower than Zetalisp on a Symbolics 3600. The difference was that nearly all type-checking and generic-function capabilities were either turned off (by the programmer) or missing in Franz LISP, where the overall environment was much poorer. Assuming that such features are not frills, I also examined the expense of providing them on different architectures.

Flexible LISP processing depends on dynamic type checking and generic operations. Associating the data type directly with the data object means that the data type will always be at hand during processing, and this is the reason that tagged memory architectures are well suited to LISP processing. Because of this association, the speed of various processors on the generic LISP task depends on how fast the processors can effectively emulate a tagged-memory architecture.

I performed a number of experiments to compare LISP systems on different processor instruction sets. As a representative sample, table 1 shows the timing results for a simple aggregate function incorporating some of the most common LISP primitives—CAR, CDR, plus, and function call/return.

More extensive benchmarks have borne out roughly the same speed ratios. Not unexpectedly, the variance

(continued)

Table 1: The timing results of the aggregate function foo for three LISP implementations on six different processors.

LISPs vs. Processors on  
(defun foo(x)(+(car x)(cdr x)))

Machine	Zetalisp	Franz LISP	PSL
VAX	53.8 $\mu$ s	13.9 $\mu$ s	5.6 $\mu$ s
68000	65.2 $\mu$ s	43.6 $\mu$ s	5.8 $\mu$ s
68010	68.6 $\mu$ s	43.6 $\mu$ s	10.6 $\mu$ s
68020	16.1 $\mu$ s	19.9 $\mu$ s	3.1 $\mu$ s
MIT CADR	19.0 $\mu$ s	n/a	n/a
3600	6.4 $\mu$ s	n/a	n/a



# Anything Better Would Have To Be Magic



	Pfs: FILE	dBASE III	RBASE	INFORMA
Development Efficiency <sup>1</sup>	N/A	40 HRS.	10 HRS.	6 HRS.
Access Time (Seconds)	7	9	2.2	7
Max. Record Size	2200	4000	1530	8000
Max. # of Fields	3200	128	300	8000
User Security	NO	NO	NO	YES
Multi-User / LAN	NO	NO	NO	YES
	\$265 <sup>2</sup>	\$695	\$495	\$199

<sup>1</sup> Galloway Study    <sup>2</sup> Includes Pfs: Report

... Easier than a  
File Manager and  
more Powerful  
than a DBMS!

## Compare INFORMA:

- **User-Oriented** — Menu-driven - no complex commands to learn or remember; only two finger typing skills needed; information retrieval and change procedures can be mastered in less than 20 minutes. Create applications and complex reports by "painting" what you wish to see on the screen.
- **Powerful** — Create a simple contact name file in minutes or a complex point of sale inventory management database in just days. In a comparison study done by Galloway Partnership of St. Louis, Missouri, a functional, online, order entry/inventory management system was created using INFORMA in 6 hours. Creation of the same system with dBASE III took 40 hours and with RBASE 4000 it took 10 hours.
- **Flexible** — Change any database as often as your needs change. No need to worry about loss of data. INFORMA does all the work at a touch of a button.
- **Growth-Oriented** — Start with a single user version now, then later, when you expand into a LAN environment, upgrade to a LAN version of INFORMA, and all of your applications automatically become Multi-User.



**UNLIMITED PROCESSING  
INCORPORATED**

8382 Baymeadows Road, Suite 8  
Jacksonville, Florida 32216  
(904) 731-8330 and (800) 874-8555  
Telex 350754

### Introductory Offer

Single-user

**\$199**

regularly \$795

LAN/Multi-user

**\$599**

regularly \$1495

Offer Expires April 10, 1985

Pfs: FILE & Pfs: REPORT are trademarks of Software Publishing Corporation; dBASE III is a trademark of Ashton-Tate; RBASE is a trademark of MicroRIM, Inc.



Listing 1: MC68010 assembly-language code for the LISP function CAR. The code in boxes can be replaced by enhancements to the instruction set to decrease the code's execution time.

Zetalisp car for 68010

```

;To take the car we do a few lines of in line code and
;then index jump to a subroutine. (Space for time.)
;The cons cell to take the car of is assumed in a0.

;dispatch to CAR subr based upon the tag in upper bits of a0

4   move1 a0,d2      ;put a copy of the arg into d2
24  lsl   #8,d2      ;first 8 of: shift copy over by 9 bits

10  lsl   #1,d2      ;last 1 of: shift copy over by 9 bits
14  andl  #0x1F0,d2  ;and off non-tag (shifted over)
4   move1 d2,a2      ;need tag in A-reg for dispatch
18  jsr   CAR(a2)    ;branch to car table indexed by type

;At return, the car of the object is in a2

```

;The CAR subroutine.

CAR + DTP-CONS: ;CAR procedure entry point

;for normal cons cell.

;We will arrive here if the argument passed to car was of type

;"pointer to cons cell". Other objects passed to car => error

;follow the point to the car

```

4   moveal a0,d2      ;put a copy of the arg into d2

```

```

14  andl  #0xFFFFF,d2 ;and off tag
4   moveal d2,a2      ;put d2 into an address register
12  moveal (a2),a2    ;follow the car pointer.

```

;dispatch to TRANSPORT subr based upon the tag

; in the upper bits of a2

```

4   move1 a2,d2      ;put a copy into d2
24  lsl   #8,d2      ;first 8 of: shift copy over by 9 bits

```

(continued)

exceeded 50 percent. Slight modifications of the compilers or instruction sets produced similarly large changes in the speeds.

Existing Franz LISP and PSL (reference 12) compilers for the DEC VAX and Motorola 68000 were used to compile foo. Type checking was turned off to obtain the fastest speeds. (Both PSL and Franz LISP were told not to verify that the arguments of + were small integers; Franz LISP did and PSL did not check for numeric overflow.) The timing figures were generated by examination of the assembly code produced and some actual machine timings. The timings of Zetalisp for the 3600 and CADR were taken by running existing systems. Zetalisp-like operations for the DEC VAX and Motorola 68000s were hand-coded, and the timings were produced in the same way as those for PSL and Franz LISP. The 68000 and 68010 were 10-MHz, no-wait-state machines. The 68000 used 24-bit addresses, leaving the upper 8 data bits free for tag values. The 68010 used 32-bit addresses and required removal of the tag bits with an AND operation before addresses could be used. The 68020 timings are estimates based upon the best "cache case" timings in the 68020 data book and are not as accurate as the timings for the other machines. The 68020 is assumed to be running at 16 MHz with an external 16K-byte memory cache and memory-management unit (MMU), giving a memory-access time of 185 nanoseconds. (The 68020 has an additional small instruction cache on board.)

Other experiments examined the architectural requirements for fast computation of some AI operations not directly supported by LISP, in particular unification and associative search. When AI languages are fully compiled, these two functions often become the computational bottlenecks. For traditional microprocessor instruction sets, the requirements of these operations turned out to be the same as for LISP primitives: fast simulation of tagged architectures. More specifically, the instructions and

capabilities that would make a conventional microprocessor better suited for LISP (along with Prolog, Krypton, MRS, PEARL, etc.) are:

- "Extract bit field and dispatch": an instruction to extract a sequence of bits from an operand, then add these bits to a dispatch table address, and jump indirect. This is necessary for rapid handling of tag values in generic operations, type checking, and for helping with unification.
- "Extract two bit fields, concatenate, and dispatch": an instruction for dispatching on the context of two operands (needed for the same reason as the one-argument version).
- The memory address system of the processor should ignore the upper address bits of data addresses that are not otherwise in use. This allows the wasted space in 32-bit pointers to be used as a tag field.

In the Zetalisp-like code, more than 30 percent of the time on the 68000s was spent in emulating the bit-field dispatch instructions. Stripping off the tag bits accounted for approximately another 10 percent. It is therefore estimated that if the existing microprocessors had hardware support for these features, full type-checking LISPs (like Zetalisp) could run almost twice as fast. These percentages come from hand-implementing several Zetalisp primitives on current microprocessors. As an example, listing 1 shows the 68010 assembly language code for CAR. The number of processor clock cycles per instruction is shown in the left-hand column. The boxed code can be replaced by a single instruction (see listing 2).

Listing 2 shows CAR for the 68010 recoded, assuming two architectural refinements. First, assume that the upper 7 bits of all addresses are ignored by the virtual-memory system. Second, assume one additional instruction, "extract bit field and dispatch." This instruction takes the bit field out of the second argument, as specified by the first argument (format: `<#starting-bit, field-width>`), adds it to the third argument (the jump-table

*(continued)*

```

10  lsll  #1,d2      ;last 1 of: shift copy over by 9 bits
14  andl  #0x1F0,d2  ;and off non-tag (shifted over)
   4  movel d2,a3    ;need tag in A-reg for dispatch
10  jmp   TRANSPORT(a3) ;branch to car table
                               ;indexed by type.
                               ;The reason for this jump is to check
                               ;for possible invisible pointers, unbound, etc.
```

TRANSPORT + NORMAL: ;jump entry point for normal

                  ;cons cell contents

8 rts              ;We're all done, return

-----  
182 clocks, @10MHz = 18.2μs

**Listing 2:** *The modified listing 1 code, incorporating architectural refinements to the processor's instruction set.*

```

;Now the car routine is recoded using the new instructions:

;index jump to a subroutine.

;dispatch to CAR subr based upon the tag in upper bits of a0
   22  extract-dispatch <#26,#6>,a0,CAR
;The CAR subroutine.
CAR + DTP-CONS: ;CAR procedure entry point for
                 ;normal cons cell.

;follow the pointer to the car
   12  moveal (a0),a2 ;the upper 6 bits of a0 are ignored.

;dispatch to TRANSPORT subr based upon the tag
;in the upper bits of a2
   22  extract-dispatch <#26,#6>,a2,DISPATCH
TRANSPORT + NORMAL: ;jump entry point for normal
                    ;cons cell contents
   8  rts              ;We're all done, return
```

-----  
64 clocks, @10MHz = 6.4μs, 2.8 times faster



base address), and indirectly jumps through this address. (The 68020 has a fast bit-field extraction instruction. This accounts for much of its increased speed over the older 68000 on the LISP task in table 1.)

For new, fully custom machine designs that are tailored specifically for AI, such features can all be built in.

With a tagged architecture, many generic operations, such as add, do not need to be dispatch subroutine calls. Rather, the processor can examine the tags of the arguments to an add instruction and, if they are simple integers, directly perform the add. If the arguments are of a more exotic numeric type, the processor can

generate a software interrupt to an appropriate routine. Further, for such designs it is very helpful to have a "smart" memory subsystem capable of rapidly chasing down indirect pointers as on the DEC PDP-10 and the custom LISP machines. Additional customization of an AI instruction-set design generally falls into the category of complete, attached coprocessors rather than just additional instructions. This tactic has already been taken by many microprocessors whose floating-point instructions are handled by what could be viewed as attached coprocessors. The specific categories of important attached coprocessors include pipelined unifiers, associative-memory subsystems, multiprocessor communication packet switchers, and special signal-processing chips for vision and speech.

Studies of a custom instruction set for the FAIM-1 machine indicate that not only can a single processor be designed that is memory-bound by DRAM (dynamic random-access read/write memory) access delays but that this is the case even when a large cache is employed. This is an important fact. It means that parallel machines sharing a single large common memory are a bad idea because there isn't enough memory bandwidth to go around.

**PARALLELISM: THE GREAT HOPE**

Traditional views cite concurrency as a great method of obtaining increased computational power. In practice, however, designers continue to concentrate on making faster and faster single-processor machines. Now that hard technological limits have been reached for serial processors, parallelism has become recognized as perhaps the only hope for further performance increases. Unfortunately, concurrency is not free—it brings new systems organization problems to the fore.

The first conceptual problem with parallelism is the confusion between *multiprocessing* and *multiprocessors*. There are algorithms that very elegantly express a set of cooperating processes

*(continued)*



**LATTICE WORKS**

**GSS SELECTS LATTICE FOR GRAPHICS SOFTWARE**

Graphic Software Systems (GSS) and Lattice, Inc. recently joined forces to offer VDI & GKS graphics, based on the emerging ANSI standard, for the C language. As a result, Lattice is marketing graphics-based software that takes full advantage of the capabilities of personal computers.

According to Lattice President David A. Schmitt, "this coupling will

allow the direct application of creative ideas without the constraints of many large-scale systems. Software development firms can develop graphics programs faster and at less cost."

The two companies also agreed to a continued sharing of technology which will support the development of standardized graphics software and ease the distribution of products.

**LATTICE UNVEILS FOUR PRODUCTS**

Lattice has announced the availability of four new software products for MS-DOS environments:

**C-SPRITE** is a software tool that simplifies debugging of programs written in Lattice C or assembly language. Cost: \$175 per copy.

**LMK** is an Automated Product Generation Utility (UNIX "MAKE") that enhances productivity and relieves the tedium of rebuilding complex software systems or documents. Cost: \$195 per copy.

The **TEXT MANAGEMENT UTILITY PACKAGE** includes utilities to search a set of files for simple or complicated patterns, to see the exact minimal differences between two text files, and to modify one or more text files automatically. Cost: \$120 per copy.

**CVUE** is a full screen text editor that supports all normal screen editor functions and includes a configuration program to define tabstop positions, horizontal scrolling and edit commands. Cost: \$100 per copy.

For complete information on these new products, contact Lattice.

**LATTICE C NAMED 'BEST OF 1984'**

The Lattice C compiler has been rated 'Best of 1984' by PC Magazine. According to columnist Peter Norton, "The Lattice C compiler is quite good ... and in my opinion noticeably better than any of its competitors. Lattice C generates code that is quite compact and fast running; the closest competitor in my tests generated code that was about 10 to 15 percent bulkier."

**ASK ABOUT OUR "TRADE UP TO LATTICE C POLICY"**

*After purchase, return registration cards for free subscription to the "Lattice Works" newsletter and important information about the Lattice Users Group*

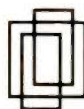

Lattice, Inc.  
P. O. Box 3072  
Glen Ellyn, IL 60138  
(312) 858-7950  
TWX 910-291-2190





# Resolution That Blows You Away

Being #1 has its advantages!  
Our Model 440 (720 by 400) Ultra High-Res monitor is the World's standard for excellence. Its capabilities will out-rank

those of our competitors for a long time.  
We won't Stop producing the finest!  
You can't!  
Not when you're Number One!



## MODEL 440

12 inch Ultra High-Res RGB Color Monitor  
Designed for up-grading display of IBM PC  
720 x 400 line resolution in non-interlaced mode  
4000 character display capability  
Switchable to green character display



## MODEL 425

12 inch Super High-Res RGB Color Monitor  
Fully compatible with IBM PC and PC Compatibles.  
640 x 262 line resolution  
Switchable to green character display  
Built in audio

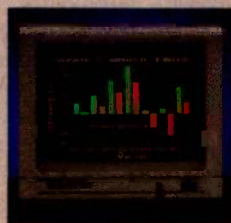

## MODEL 420L

12 inch Super High-Res RGB Color Monitor  
Long Persistence Phosphor Tube  
Fully compatible with IBM and most other personal computers.  
640 x 262 line resolution in non-interlaced mode  
640 x 525 line resolution in interlaced mode  
Unlimited colors available through analog video circuit



## MODEL 411

12 inch High-Res RGB Color Monitor  
Fully compatible with IBM PC and PC Compatibles.  
510 x 262 line resolution  
Switchable to green character display  
Built in audio



## MODEL 122

12 inch Super High-Res Amber Display  
Fully Compatible with IBM TTL Monochrome Display  
Horizontal scan.  
Rate 8,432 Khz  
Optional Tilt/Swivel Base available (Model 110-12)  
**Green phosphor available (Model 121)**

# TAXAN

**The Smart Choice.**

Inquiry 424 for Dealers. Inquiry 425 for End-Users.

18005 Cortney Ct. City of Industry, CA 91748 **(818) 810-1291**

© 1985 TAXAN Corporation

\*IBM is a registered trademark of International Business Machines, Inc.



# C PROGRAMMERS

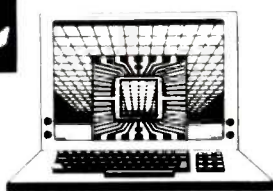

## db\_VISTA

**The first DBMS designed exclusively for the C language.**

PREFERRED over ISAM and file utilities  
POWER like a mainframe DBMS  
PRICED like a microcomputer utility  
PORTABILITY like only C provides

### FEATURES INCLUDE:

- Written in C, for C.
- Maximum data efficiency using the network database model.
- Virtual memory disk accessing.
- Fast B\*-tree indexing method.
- Multiple key records-any or all data fields may be keys.
- ROYALTY FREE RUNTIME.
- SOURCE CODE INCLUDED.
- Three month extended applications support included.

### FREE OFFER

MENTION THIS AD and choose any one of the following C tools from Lattice at no additional charge, when you order db\_VISTA

- Lattice C Compiler
- C-Sprite Program Debugger
- Lattice Window Manager
- Curses Unix-compatible Screen Manager (source code included)
- Panel Forms Manager
- CVUE Screen Editor

db\_VISTA with source code: \$495  
db\_VISTA without source code: \$395

### OR

COMPLETE C Development package including:

db\_VISTA, Lattice C compiler, C-Sprite, CVUE, & Curses  
a \$1520.00 value for only \$895.00

db\_VISTA available for PC-DOS/MS-DOS, for most popular C compilers including Lattice, DeSmet, Computer Innovations, AZTEC. Also available for most Unix systems and CTOS.

## RAIMA

CORPORATION  
11717 Ramier Avenue South  
Seattle, WA 98178  
206/772-1515

CALL TOLL-FREE  
1-800-843-3313  
at the tone: 700-992  
ask for Jim

**MONEY BACK GUARANTEE**

## ARCHITECTURES

(e.g., writers and readers), but these same algorithms have little or no inherent parallelism that can be exploited by parallel computers. Just because an algorithm can be expressed in concurrent terms is no guarantee that, when run on many parallel processors, it will run significantly faster than as separate processes on a single sequential machine.

The true measure of parallelism is how much faster a given program will run on  $n$  simple parallel processors compared to how fast it would run on a single simple processor and for what ranges of  $n$  this is valid. The best you can hope for in principle is a factor of  $n$  speedup, but in practice this is rarely reached (due to overhead and communication contention). The maximum amount of speedup attained for a given program using any number of parallel processors indicates the inherent parallelism of that program. Unfortunately, for most existing programs written in traditional computer languages, the maximum parallelism seems to be about a four-times speedup (reference 10). This surprisingly low number is due to the style of programming enforced by the traditional languages. There are special-purpose exceptions to this rule and the hope is that nontraditional parallel languages will encourage more concurrent algorithms. Compilers for parallel machines can take advantage of techniques such as and, or, and stream parallelism if AI languages support the concurrent control structures that give rise to them. But the jury is still out as to the amount of speedup such techniques can deliver.

Another problem in parallelism is failure to take the entire systems context into account. Before building a parallel machine, you must not only simulate the machine but determine how to write large programs for it. This reveals potential flaws in the machine before commencing with time-consuming hardware development. The simulation must properly take scheduling and technologically realistic hardware-communication

overhead into account or the timings produced will have little or no connection to reality.

Good examples of software systems that have not taken realistic hardware considerations into account are some of the parallel LISPs that have been proposed (reference 9). These proposals point out places in LISP-like processing where multiple processors could be exploited, but they do not analyze the overheads incurred. They usually assume that multiple processors share a single large main memory where CONS cells and other LISP objects are being stored. This is the equivalent of assuming that memory is infinitely fast, which is just as unrealistic as assuming that processors are infinitely fast. The problem is that with current technology a single well-designed LISP processor could run faster than current mass-memory technology could service it. Adding processors would thus not result in any increase in throughput.

There are several reasons why designers of parallel LISPs may have missed this fact. Perhaps one is that current 68000 LISPs are not memory-bound. Another is the potential use of caches to reduce the required memory bandwidth to each processor. However, even with caching, the number of processors that can be added is not unlimited; a 90 percent hit-rate cache would accommodate only 10 processors.

What about the thousand-processor architectures envisioned? Experimental data shows that a single processor can run significantly faster than memory can service it. You must employ a cache just to keep a single processor running full tilt. The lesson is that processors are still much faster than memories, and any sharing of data between multiple processors (beyond a few) must be done with special communication channels. In other words, MIMD (multiple instruction, multiple data) machines with a single shared memory are a bad parallel architecture. This has important implications for some AI paradigms, such as Blackboard sys-

tems and Production systems that (in their current form) rely on memory for communication between tasks.

This is not to say that there are no opportunities for spreading LISP-like processing across hundreds of processors. There are many techniques other than a single shared-memory system for connecting processors. More realistic areas of research include the spreading of parallel inference computation via techniques of and, or, and stream parallelism. The point is that all of these techniques incur some overhead and you cannot simply solve the parallel-computation problem by saying that arguments to functions should be evaluated in parallel. You must first study hardware technology to determine at what grain sizes parallelism is feasible and then figure out how to make AI-language compilers decompose programs into the appropriate-size pieces.

### CUSTOM VLSI

One of the principal hopes for more efficient future computation is the use of custom VLSI hardware to accelerate particular functions. The ideal functions for silicon implementation should be current bottlenecks in AI systems and generic to many AI tasks. Four of the most important classes of

operations that fit this description are symbolic matching of abstract objects, semantic associative memory, parallel-processor communication, and signal-to-symbol processing.

### MATCHING AND FETCHING

*Matching* two objects is a general and pervasive operation. Most AI languages define one or more *match* functions on their structured data types (such as frames). Some of these match functions are very ad hoc (thus supposedly flexible), but others are subsets or supersets of unification. If significant support for matching is to be provided in hardware, the match function must have well-defined semantics.

AI-language objects can be complexly structured and used to represent semantic knowledge. The objects can contain embedded pattern-matching variables that are given bindings as a side effect of the match operation. Thus the matching of these objects is complex. To give the flavor of the matching process, I'll present a short description of the unification matching function. (For a more exact description, see any good description of the Prolog language.) Matching is best described by recursively defining the semantics of the match operation:

1. If the two objects to be matched are structured (nonscalar) objects, recursively match their subcomponents (or "slots"). The two objects are said to match if and only if all pairs of slots match. Otherwise, the objects do not match, and any side effects of the matching process must be undone.
2. If the two objects to be matched are scalar objects (integers, floating-point numbers, atoms, symbols, characters, etc.), then the match function reduces to simple equality.
3. If one of the two objects to be matched is a pattern-matching variable, the match operation must check the variable's binding state. If the variable already has been bound to a value, the match operation continues using the value in place of the variable. If the variable has no current binding, it is bound to the value of the object against which it was being matched, and the match succeeds.
4. If both of the objects to be matched are unbound pattern-matching variables, then one is bound to the other as a placeholder for possible future bindings. If either variable is later bound to a "real" value, then both variables will be bound to this value.

(continued)

# PROFESSIONALS

From computer systems to support . . . Dynacomp serves Canada.\*

When you're ready to buy a computer, consider the difference professionals can make. You want full support from your dealer, and complete reliability from your computer. At Dynacomp, we offer both.

Dynacomp is Canada's 1st Full Service CompuPro System Center offering you the most cost-effective and advanced business and scientific computers available. . . CompuPro's System 816™ family and the multi-user CompuPro 10 PLUS™. And we

now offer UNIX™ on CompuPro, UniPlus™ + SYSTEM V for \$1495. U.S. list\*\* on the CompuPro 816/E™

Our support includes giving you the most computer for your money. Tell us what you do, and we'll put together a complete system that meets your needs . . . right down to the peripherals.

Our CompuPro systems include a library of the most popular and useful software, CompuPro's full year warranty and Xerox®

on-site service with designated systems.

Call Dynacomp for the professional support you expect when you buy a computer system.

Since 1982, Full Service CompuPro System Center. **CompuPr**

\*Dynacomp serves all Canada and parts of Asia and the Pacific Rim. Call for details and information on our full product line including Plexus, Mac and Ampro.

CompuPro System 816 and CompuPro 10 PLUS are trademarks of Cor. Xerox is a registered trademark of Xerox Corp. UNIX is a trademark of B Laboratories, Inc. UniPlus is a trademark of UniSoft Corp.

\*\*Dealer inquires welcome.

210 W. Broadway  
Vancouver, B.C. V5Y 3W2  
(604) 872-7737

**DYNACOMP**  
COMPUTER SYSTEMS LTD.

74-6535 Mill Creek Dr.  
Mississauga, Ont. L5N 2M  
(416) 826-8002



The match operation produces a binary result: Did the two objects match successfully or not? Successful matches produce the bindings of pattern-matching variables necessary to make the two objects identical in as general a way as possible.

Many AI languages augment this match operation with checks for circularity in the list structure (the "occur check"), segment matches (similar to Snobol's), and the matching of sets and bags.

When a match function is applied

to a database of objects, the operation is called *fetching*. In this case matching becomes the inner loop operation, and this is a context in which matching should be optimized. An ideal solution would integrate matching circuitry with memory circuitry so that fetching would become a memory access of a content-addressable memory (CAM). The choice of match function is critical. To obtain reasonable memory densities, the relative silicon area of match circuitry cannot overwhelm that of the

memory circuitry. Unfortunately, full unification and more complex match functions require too much circuitry to be built into memory cells. But if a formal subset of unification could be built in, then the CAM could act as a prefilter function for unification.

The primary source of unification complexity is the maintenance of the binding environment. The match function of *mock unification* resembles full unification except that all variables are treated as "don't cares" and no bind-

(continued)

## FAIM-1 PROJECT OVERVIEW

**O**ur goal is to produce a *high-performance symbolic multiprocessor*, 100 or more times faster than current machines in common use (e.g., the DEC VAX-11/780) to meet the voracious computational demands of future artificial-intelligence applications.

The FAIM-1 (Fairchild Artificial Intelligence Machine) is a multiprocessor system consisting of a number of identical processing elements called *hectagons* interconnected by a communication network. Each hectagon is a complete computer capable of sequentially executing a compiled program that is stored in its local memory. Hectagons communicate with each other via messages that are sent through communication ports. A hectagon has six ports that may be active concurrently.

The FAIM-1 architecture permits the connection of arbitrary numbers of hectagon processing elements in a hexagonal-mesh topology. The ensemble of hectagons is capable of exploiting very large levels of concurrent multiprocessing and as such should provide an extremely attractive target machine for future concurrent AI applications due to its performance. Moreover, each individual hectagon is itself a concurrent processor composed of six modular subsystems, each of which provides an important level of support for symbolic computation.

A hectagon is composed of six self-titled subsystems named FRISC, SRAM, ISM, CxAM, SPUN, and Post Office. Three of these subsystems (ISM, CxAM, and SRAM) are specialized

memory systems that provide "intelligent" storage, while the other systems support inter-hectagon communication (Post Office), processing (FRISC), and unification (SPUN).

**FRISC:** The "fanatically reduced instruction set computer" component of the hectagon corresponds to the central processing unit in a conventional computer. It is a stack-oriented machine with a 20-bit word composed of a 16-bit data field and 4-bit tag field. Tag bits and associated tag-handling hardware support generic operations. **SRAM:** The FRISC views most data structures as objects; a conventional memory with a small finite-state machine attached to it (collectively called the SRAM) provides an object-oriented memory system for the FRISC. For example, using the data tag bits the SRAM can chase a pointer chain to retrieve an object requested by the FRISC.

**ISM:** The "instruction stream memory" subsystem delivers instructions to the processor at high speed. Thus, the normal address calculation activities that have traditionally been the processor's responsibility are the ISM's job.

**CxAM:** The "context-addressable memory" subsystem provides direct hardware support for important pattern-matching functions inherent in symbolic programs. The structure of both entries and queries in the CxAM is an S-expression. Therefore, each slot can either be a structure or an atom. Atoms can be symbols, numbers, vari-

ables, or *don't cares*. The CxAM responds to four commands: Find Match, Give Match, Delete Structure, and Add Structure. The CxAM manages its own free space and removes garbage automatically.

**SPUN:** The "streamed pipeline unifier" supplies direct hardware support for logic programming. The CxAM finds the next rule or set of rules to be tried but does not perform full unification since its match function does not consider variable bindings. The SPUN unit takes the query and the streamed set of matched structures, detects which variables still need to be matched, fetches the binding in the current context from the SRAM, and completes the unification. This may entail binding a variable, in which case the SPUN unit must post this binding back in the SRAM. More complex structure manipulation requires the SPUN to interrupt the FRISC for services.

**Post Office:** Hectagons communicate by sending messages to each other; it is the duty of the Post Office to provide autonomous communication support for its hectagon. If a message's destination is not one of the sender's six neighboring hectagons, the Post Office will route the message to its destination by sending the message to a neighbor that is *generally* in the direction of the destination.

Conceptually, messages may be of arbitrary length. In fact, each message is broken up and sent as a sequence of fixed-length packets.



# MARCH INTO SPRING WITH.....

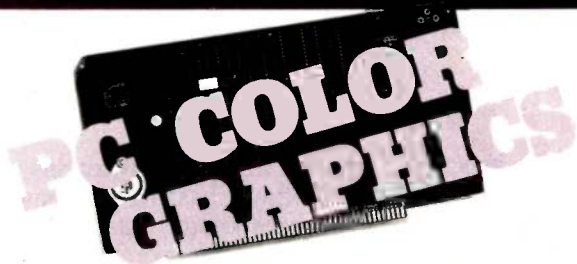

## COLOR MAGIC: IBM-PC compatible \$100 BUS graphics board.

Gives your 16 bit \$100 BUS system IBM-PC compatibility. ■ RGB and composite outputs ■ IBM PC keyboard port ■ All IBM-PC display modes plus two higher resolution modes

PRICE . . . . .16K — \$595.00 . . . . .32K — \$695.00



## LIGHTNING ONE: The standard by which other 16 bit boards are judged.

The LIGHTNING ONE offers math processing capabilities only available on large mainframes previously. ■ Up to 10MHz operation ■ 8MHz 8087 option ■ Optional 8089 coprocessor

PRICES start at \$425.00 8086/87 (8MHz) \$900.00  
 . . . . .8086 (10MHz) \$625.00



## MEGARAM: High performance high density Dynamic RAM.

Offers cost effective memory expansion in 16 bit systems. ■ No wait states with 8086's up to 10MHz ■ Only one wait state with 6MHz 80286 ■ Up to two MegaBytes of memory

PRICE . . . . .256K — \$595.00 . . . . .512K — \$1095.00  
 1024K — \$1995.00 . . . . .2048K — \$3795.00



## THUNDER 186: Single board 16 bit microprocessor offers 10MHz 8086 performance.

THUNDER requires no other support boards. ■ 256K RAM ■ FDC controller ■ 2 Serial ports ■ Parallel printer port ■ Concurrent DOS is included

PRICE . . . . . \$1595.00



## LIGHTNING 286: Highest performance processor available on the \$100 BUS.

This 6MHz 80286 offers performance equivalent to a 14 MHz 8086. ■ 5 times IBM-PC performance ■ 16 Mbyte physical memory space ■ 1 Giga byte virtual address space

PRICE 80286 — \$1095.00 80286/287 — \$1649.00

## NEW PRODUCTS!

### ■ WINCHESTER/FLOPPY CONTROLLER

Controls both floppy drive and Winchester drives from one board. Save slots and money. Features include: error correction, 16 head control, mixed 5 1/4 and 8" floppy drives. The price is less than one popular manufacturer charges for a floppy only controller. PRICE . . . . . \$649.00

### ■ MEMORY DISK

I/O mapped memory drive expandable to 16 Mbytes by cascading boards. Each board may contain up to 2 Mbytes and may be battery protected. Parity is included to insure corrupted data does not go undetected. The board is entirely COMPUPRO software compatible. PRICE . . . . . 2 MBYTES . . . . . \$2595.00

Dealer inquiries invited.



## LOMAS DATA PRODUCTS, INC.

66 Hopkinton Road, Westboro, MA 01581  
 Tel: (617) 366-6434 □ Telex: 4996272

For orders outside the U.S., contact our dealers:

- Australia — LAMRON PTY. LTD., (02 808-3666)
- England — FULCRUM 0621828763, RATIONAL SYSTEMS 0908-613209 or 0908-611349.

## Computer Systems . . .

LOMAS DATA PRODUCTS offers a full line of single and multi-user computer systems, including systems compatible with the IBM-PC and PC-AT. If you have a requirement for a high performance 16 bit computer system and require IBM-PC compatibility call LOMAS DATA PRODUCTS, the only supplier of \$100 BUS PC compatibles.

Prices and specifications are subject to change.

\*CP/M-86, MP/M-86 and CONCURRENT DOS are trademarks of Digital Research.  
 \*\*MS-DOS is a trademark of Microsoft.  
 \*\*\*Lightning One is a trademark of Lomas Data Products, Inc.  
 \*\*\*\*PC-DOS is a trademark of IBM



ing list is formed. In terms of the definition given above, steps 3 and 4 would be replaced with null operations—variables are just treated as “always match” objects. Mock unification is the most powerful subset of unification that is state-free. Therefore, mock unification is a suitable candidate for integration into VLSI memory. Associative-memory systems that utilize mock unification as their match function are called CxAMs: context-addressable memories.

From a hardware point of view, designing associative-memory architectures involves a resource trade-off between processing and memory: The more hardware devoted to “matching,” the more data that can be examined in parallel, leading to faster

search time per bit of storage. But conversely, the more matching hardware there is, the smaller the amount of hardware that can be devoted to data memory and the lower the density of the associative memory. The data-path bandwidth of the match hardware is also a factor in making these trade-offs. Therefore, associative memories can be rated by their storage density (bits stored per unit of silicon area) and search throughput (bits searched per unit of time per unit of silicon area).

I examined two classes of associative memory in which the match function is mock unification. One integrated the matching circuitry with memory circuitry, the other was hash-based. Hashing was considered

because in many applications in the past software hashing has dominated CAM technology (reference 7). In more detail the two classes are

1. Brute-force search: The contents of a memory are exhaustively searched by some number of parallel match units. For this class of search a custom VLSI mock-unification-memory architecture was designed.
2. Hashing: Objects to be fetched are hashed, and then the collision list is serially searched by a match unit. A proposed VLSI implementation of PEARL's hashing scheme (called the HCP, or hash coprocessor) served as an embodiment of hash-based searching. In this system the bit storage is conventional DRAM.

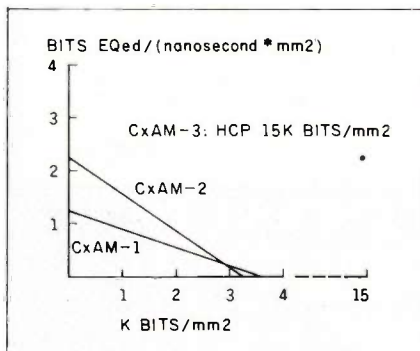

Figure 1: A graph of the range of bit and search-power densities for a CxAM design.

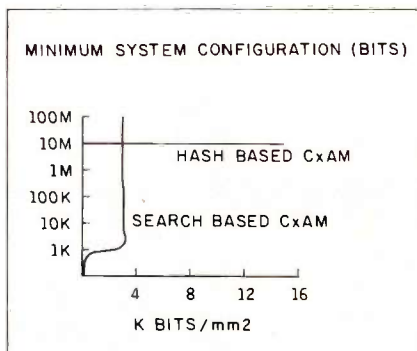

Figure 2: The minimum-usable-size system for use with the hashing CxAM. Note that the minimum is too large for some applications.

Figures 1 and 2 present graphs of CxAM design-space trade-offs. Figure 1 displays the range of bit and search-power densities. The hash-based CxAM has a single operating point because the fetch time is essentially independent of memory size, as is the density. The search-based CxAM has a variable range because one can vary the relative proportions of storage and processing in such architectures. The two lines represent two different search-based architectures. One has inherently better bit density, but over most of the design space this advantage is negated by an inherently worse search throughput. However, neither design completely dominates the other—a choice between the two will depend on the relative storage-density/match-throughput balance desired. Figure 2 displays the defect of the hashing CxAM. The minimum-usable-size system is too large for some applications.

Thus the trade-offs between these two schemes turn out to be in density and minimum usable size. As a representative data point, both techniques could perform a mock unification of their entire local memory contents for an average query (an S-expression of length 16) in 5 microseconds. The density of the search-based CxAM was about eight times worse than that of conventional single-transistor DRAM. The hashing

Table 2: A list of AI-language match operations and data types arranged in order of complexity.

Match Hierarchy

Match Operation	Object Type
Compare Instructions	32-bit data object
LISP EQ Function	Atomic LISP objects
LISP EQUAL Function	S-Expressions
Mock Unification	S-Expression with don't cares
Unification	S-Expression with matching variables
Unification & Predicates	S-Expression with variables/predicates
Arbitrary User Code	arbitrary user representation objects

**Little Board™ \$349\***

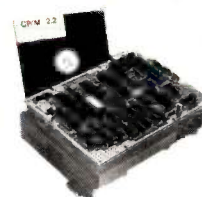

CP/M 2.2 INCLUDED

\*UNDER \$200 IN OEM QUANTITIES

- 4-MHz Z80A CPU, 64K RAM, Z80A CTC, and 2732 Boot ROM
- Mini/Micro Floppy controller (1-4 Drives, Single/Double Density, 1-2 sided, 40/80 track)
- Only 5.75 x 7.75 inches, mounts directly to a 5 1/4" floppy drive
- Two RS232C Serial Ports (75-9600 baud and 75-38,400 baud), 1 Centronics Printer Port
- Power Requirements: +5VDC at 0.75A; +12VDC at 0.05A/On-board -12V Converter
- CP/M 2.2 BDOS • ZCPR3 CCP
- Enhanced AMPRO BIOS
- AMPRO Utilities included:
  - Read/write to more than two dozen other formats (Kaypro, Teletype, IBM CP/M86..)
  - Format disks for more than a dozen other computers
  - Menu-based system customization
- BIOS and Utilities Source Code available

**BOOKSHELF™ Series 100**

MODEL	QTY 1 PRICE
121 1 400K DSDD Drive	\$ 895.00
122 2 400K DSDD Drives	995.00
142 2 800K DSQD Drives	1,195.00



- Little Board CPU
- Runs thousands of CP/M programs
- Enhanced Operating System including ZCPR3 CCP and FRIENDLY™ Integrated Operating Environment.
- Word Processing, Electronic Spreadsheet, Database Management, Spelling Checker all included (complete T/maker Pkg.)
- 6 1/8" high, 7 1/4" wide, 10 1/4" deep, 12 1/2 lbs.

**SCSI/PLUS™ Adapter**

Compatible with most Z80 Systems (send \$10 for complete specifications)

\$99 QTY 1

- Mounts directly to Little Board
- Multi-Master high-speed parallel bus
- SASI-SCSI compatible
- General purpose I/O expansion bus up to 64 devices
- Allows multi-Little Board Systems and resource sharing
- Little Board hard disk software/source \$79 QTY 1

**DISTRIBUTORS**

- Argentina-Factorial, S.A. . . . . 1-41-0018
- Australia-ASP Microcomputers . . . . 613-500-0628
- Belgium-Centre Electronique Lempereur . . 041-23-45-41
- Canada-Electronic Sales Assoc . . . . (604) 986-5447
- Denmark-Danbit . . . . . 03-66-20-20
- England-Quant Systems . . . . . 01-534-3158
- Finland-Symmetric OY . . . . . 358-0-585-322
- France-EGAL+ . . . . . 1-502-1800
- Israel-Alpha Terminals . . . . . 03-491695
- Spain-Xenios Informatica . . . . . 3-593-0822
- Sweden-AB AKTA . . . . . 08-54-20-20
- USA: Digital Distributors (CA) . . . . . 408-423-1556
- Peripheral Business Systems (WA) . . . . 206-823-6661
- Dorado Business Systems (NY/NJ) . . . . 609-429-2243

Z80A is a registered trademark of Zilog, Inc. CP/M is a registered trademark of Digital Research.



COMPUTERS, INCORPORATED

67 East Evelyn Ave. • Mountain View, CA 94041  
(415) 962-0230 • TELEX 4940302

scheme used conventional DRAMs and so had high density. But the minimum configuration of a hash-based CxAM memory system using standard 256K-byte DRAMs is 10 megabits, whereas the search-based CxAM can be configured for much smaller system storage sizes.

This extremely high speed of 5 microseconds portends greatly increased efficiency for systems bottlenecked by database fetch time. But which technique to use is very dependent upon grain size. If you are constructing a large nonparallel machine, a bank of HCPs and conventional DRAMs works well. But for an array of small-grain processors with on-chip memories, the search-based CxAM approach is more tractable.

Combining a CxAM with software-based routines provides a range of tailored matching services with sliding power/price/throughput trade-offs. The FAIM-1 machine provides an example of this design. For each of thousands of processors, there is parallel CxAM hardware for mock unification, a single, hard-wired, serial pipelined full unifier, and software support for post-unification matching features (attached predicates and demons). With such a hardware/software hierarchy, simple matches (like LISP's equal) run fast, whereas more complex matching services (such as KRLs—see reference 1) cost more in time due to the software component.

In summary, matching is a common operation ripe for VLSI implementation, but the complexity of match functions varies. Table 2 arranges a simple list of match operations and data types in order of complexity. Successful high-performance AI machines will have to carefully decompose these functions into hardware and software components.

**PARALLEL-PROCESSOR COMMUNICATIONS**

As already mentioned, processors working in parallel cannot communicate objects and messages by sharing a large common memory. Some sort of special message-passing (and forwarding) hardware is essential for ef-

ficient handling of the traffic. In many general-purpose parallel processors, interprocessor communication is the computational bottleneck.

**SIGNAL-TO-SYMBOL PROCESSING**

Despite all the attention given to speeding up high-level symbolic computation, within some AI applications the main processing bottleneck has been in the very-low-level processing of raw sensory data. Within many vision systems, 90 percent or more of the run time may be incurred in the initial segmentation of the visual scene from pixels to low-level symbolic constructs (reference 16). Moreover, limitations of the higher-level vision processing can usually be traced to an inadequate initial segmentation (reference 4). Similar problems arise in many speech systems. In such cases, you should look to special-purpose VLSI processors to directly attack the problem. Examples include special image-processing chips (reference 14), and speech chips (reference 2). As array processors have shown, for these special processors to be usable by programmers they need to be very well integrated with the other hardware and software components of the system and as transparent as possible. Since most AI programmers are not good microcode hackers, you are in trouble if this is the only interface with a special device.

**CONCLUSION**

Opportunities for increased efficiency abound at all levels of AI systems if we only look, but to obtain the desired throughput increases all the potential improvements outlined here must be made. We must make hard trade-offs between traditional AI programming practices and the discipline necessary to construct algorithms that can make effective use of large multi-processors. We must compile our AI languages, and these compilers must influence instruction-set design. Key computational bottlenecks in AI processing must be attacked with custom silicon. There is a real need to use

(continued)



concurrency at all levels where it makes sense, but the overhead must be analyzed realistically. ■

### ACKNOWLEDGMENTS

The author would like to acknowledge the contributions of members of the FAIM-I project: Ken Olum for his collaboration on the instruction-set benchmarks, Ian Robin-

son and Erik Brunvand for their VLSI CxAM designs, and Al Davis for overall architectural discussions.

### REFERENCES

1. Bobrow, D., and T. Winograd. "An Overview of KRL-0, a Knowledge Representation Language." *Cognitive Science*, vol. 1, no. 1, 1977.
2. Burlinson, W. "A Programmable Bit-Serial

Signal Processing Chip." SM Thesis, MIT Department of Electrical Engineering and Computer Science, 1983.

3. Deering, M., J. Faletti, and R. Wilensky. "PEARL—A Package for Efficient Access for Representations in LISP." *Proc. IJCAI-81*, Vancouver, B.C., Canada, August 1981, pages 930–932.
4. Deering, M., and C. Collins. "Real-Time Natural Scene Analysis for a Blind Prosthesis." *Proc. IJCAI-81*, Vancouver, B.C., Canada, August 1981, pages 704–709.
5. Deering, M., and K. Olum. "Lisp and Processor Benchmarks." Unpublished FLAIR Technical Report, March 1984.
6. Fateman, R. "Is a Lisp Machine Different from a Fortran Machine?" *SIGSAM*, vol. 12, no. 3, August 1978, pages 8–11.
7. Feldman, J., and P. Rovner. "An Algol Based Associative Language." *Commun. ACM*, vol. 12, no. 8, August 1969.
8. Foderaro, J. "The Franz Lisp System." Unpublished memo in *Berkeley 42 UNIX Distribution*, September 1983.
9. Gabriel, R., and J. McCarthy. "Queue-based Multi-processing Lisp." Preprint, 1984.
10. Gajski, D., D. Pradua, D. Kuck, and R. Kuhn. "A Second Opinion on Data Flow Machines and Languages." *IEEE Computer*, vol. 15, no. 2, February 1982, pages 58–69.
11. Genesereth, M. "An overview of Meta-Level Architecture." *Proc. AAAI-83*, Washington, DC., 1983.
12. Griss, M., and E. Benson. "Current Status of a Portable Lisp Compiler." *SIGPLAN*, vol. 17, no. 6, in *Proc. SIGPLAN '82 Symposium on Compiler Construction*, Boston, MA, June 1982, pages 276–283.
13. Knight, T., Jr., D. Moon, J. Holloway, and G. Steele, Jr. "CADR." MIT AI Memo 528, March 1981.
14. Kurokawa, H., K. Matsumoto, M. Iwashita, and T. Nukiyama. "The Architecture and Performance of Image Pipeline Processor." *Proc. VLSI '83*, Trondheim, Norway, August 1983, pages 275–284.
15. Lampson, B., and K. Pier. "A Processor for a High-Performance Personal Computer." *Proc. 7th Symposium on Computer Architecture*, SIGArch/IEEE, La Baule, May 1980, pages 146–160.
16. Perkins, W. "A Model Based Vision System for Industrial Parts." *IEEE Trans. Comput.*, vol. C-27, 1978, pages 126–143.
17. Warren, D. H. "Applied Logic—Its Uses and Implementation as a Programming Tool." Ph.D. Dissertation, University of Edinburgh, 1977. Available as Technical Note 290, Artificial Intelligence Center, SRI International.



**OEMS:** Let Systems Strategies help you cover the large, profitable marketplace of IBM™ mainframe communications. Our software allows your computer system to emulate IBM terminals, workstations and printers.

**EXPERIENCE:** As the first to develop 3270 SNA and 3270 BiSync support under UNIX™ Systems Strategies' experience can save you development time and money. Let us keep up with the changing shades of Big Blue as IBM communications evolve.

**BROADEST PRODUCT RANGE:** We have the broadest range of communications software available for UNIX and non-UNIX environments, allowing mini and micro computer systems to communicate with mainframes or networks using SNA/SDLC or BiSync. The CCITT X.25 interface is also available. Our family of products can serve your growing information access needs, now and in the future.

**COMPLETE EMULATION:** Systems Strategies provides a perfect match to Big Blue. Our products provide full SNA/3270, BSC/3270, SNA/RJE (3770) and BSC/RJE (2780, 3780, HASP) emulation. The integrated Applications Program Interface provides the capability for interactive transaction processing, file transfers and fully integrated applications across mainframe and workstation boundaries. No IBM host modification is required.

**PORTABILITY:** All of our software is written in 'C', using internal designs and architecture which make the communications and device emulation logic independent of the hardware and operating system, and thus easily portable.

Call or write today for more information.  
Systems Strategies Inc. 225 West 34th St. New York, NY 10001. (212) 279-8400.



**Systems Strategies Inc.**  
An AGS Company

**Experience... the main link in communications software**

IBM is a trademark of International Business Machines Corp. UNIX is a trademark of AT&T Bell Laboratories.

# A FEW NEAT THINGS YOU CAN DO WITH KODAK'S CAT-QUICK INSTANT SLIDE-MAKERS...



*"Make your slides one by one, save on film and have some fun!"*

*"Correct mistakes, add new facts, give a show the punch it lacks."*

*"Take CRT data off the screen, edit freely in between."*

*"Mount your slides fast and clean—project bright hues on the screen."*

*"Meet tight deadlines, do a whole show, win new clients, hear 'bravo.'"*

*"Waste no money, waste no time, get results that are sublime."*



**"If you can't do without these cat-quick instant slide-makers another minute, contact your dealer in Kodak audiovisual products, listed in the Yellow Pages under 'AV Equipment and Supplies.' Or, phone 1 800 44KODAK, Ext 293 (1 800 445-6325, Ext 293). Tell 'em Slide Cat sent you!"**



The system includes KODAK INSTAGRAPHIC Copy Stand, KODAK INSTAGRAPHIC CRT Slide Imager and CRT Adapters, KODAK INSTAGRAPHIC Color Slide Film, and KODAK INSTAGRAPHIC Slide Mounter and Mounts.

© Eastman Kodak Company, 1985



# "Despite the recent press notices, multiuser microcomputers aren't anything new!"

**This is the first in a series of discussions with Rod Coleman, President of Stride Micro (formerly Sage Computer) on the 68000 multiuser market and its current environment.**

**Q:** Why do you say that?

**RC:** "The technology to build a high performance multiuser system has been around for five years. And while some of the leaders in this industry have been pretending that micro multiuser didn't exist, we've been shipping complete systems for nearly three years. The benefits of multiuser are undeniable; it is more cost effective, and offers greater flexibility and utility. But until just recently, the marketing pressure to be compatible instead of being better, has blinded the industry."

**Q:** What do you mean?

**RC:** "Well, for example, the Motorola 68000 processor introduced 16/32-bit technology to the personal computer world a long time ago. It was fully capable of

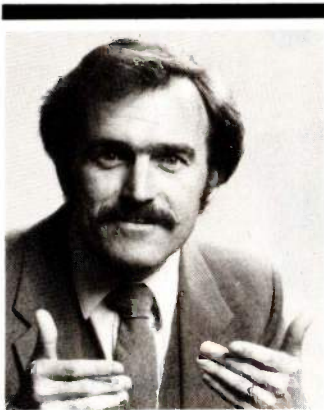

**"A surprising feature is compatibility. Everybody talks about it, but nobody does anything about it."**

meeting high performance and multiuser design requirements in 1980. Instead of this trend taking off, most energy was spent promoting 8088/8086 products that

were clearly inferior from a technical point of view. This phenomenon leads me to believe that they will soon rewrite the old proverb: 'Build a better mousetrap and the world will beat a path to your door,' but only if they can find the way through the marketing fog."

**Q:** Are things changing now?

**RC:** "Yes and no. With the business world starting to take more and more interest in microcomputer solutions, the advantages of a solid multiuser system couldn't be kept hidden forever; companies like ours and a few others were beginning to make a dent. Instead of taking a fresh approach, some of the newest multiuser offerings will probably only give the technology an undeserved black eye! Multiuser is far more than the ability to plug in more terminals. It involves things like machine compatibility, fast processors, adequate memory, large storage capacities, backup features, networking, and operating system flexibility."

**Q:** Is this what makes the new Stride 400 Series different?

**RC:** "Exactly. That sounds self-serving, but it's true. Today a number of companies are introducing their first multiuser system. We've been building and shipping multiuser machines for almost three years. We know the pitfalls, we've fallen into some of them. But we have learned from our mistakes."

**Q:** Give me some examples.

**RC:** A hard disk is almost mandatory for any large multiuser installation. Yet, backing up a hard disk can be a nightmare if you only have floppies to work with. That's why we've added a tape backup option to all the larger Stride 400 Series machines. It's irresponsible for a manufacturer to market a multiuser system without such backup. Another good lesson was bus design. We started with one of our own designs, but learned that it's important not only to find a bus that is powerful, but also one that has good support and a strong future to serve tomorrow's needs. We

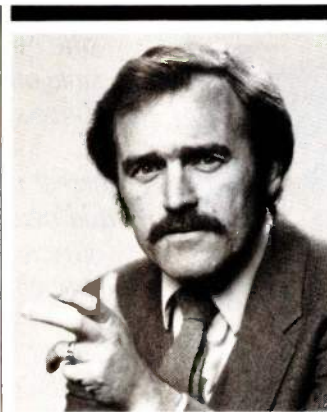

**"The marketing pressure to be compatible instead of being better, has blinded the industry."**

think the VMEbus is the only design that meets both criteria and thus have made it a standard feature of every Stride 400 Series machine."

**Q:** What are some of the other unique features of the 400 Series?

**RC:** "A surprising feature is compatibility. Everybody talks about it, but nobody does anything about it. Our systems are completely compatible with each other from the 420 model starting at \$2900, through the 440, on to the powerful 460 which tops out near \$60,000. Each system can talk to the others via the standard built-in local area network. Go ahead and compare this with others in the industry. You'll find their little machines don't talk to their big ones, or that the networking and multiuser are incompatible, or that they have different processors or operating systems, and so on."

**Q:** When you were still known as Sage Computer, you had a reputation for performance, is that still the case with the new Stride 400 Series?

**RC:** "Certainly, that's our calling card: 'Performance By Design.' Our new systems are actually faster; our standard processor is a 10 MHz 68000 running with no wait

states. That gives us a 25% increase over the Sage models. And, we have a 12 MHz processor as an option. Let me add that speed isn't the only way to judge performance. I think it is also measured in our flexibility. We support a dozen different operating systems, not just one. And our systems service a wide variety of applications from the garage software developer to the corporate consumer running high volume business applications."

**Q:** Isn't that the same thing all manufacturers say in their ads?

**RC:** "Sure it is. But to use another over used-term, 'shop around'. We like to think of our systems as 'full service 68000 supermicrocomputers.' Take a look at everyone else's literature and then compare. When you examine cost, performance, flexibility, and utility, we don't think there's anyone else in the race. Maybe that's why we've shipped and installed more multiuser 68000 systems than anyone else."



**STRIDE**  
MICRO

Formerly Sage Computer

For more information on Stride or the location of the nearest Stride Dealer call or write us today. We'll also send you a free copy of our 32 page product catalog.

Corporate Offices:  
4905 Energy Way  
Reno, NV 89502  
(702) 322-6868

Regional Offices:  
Boston: (617) 229-6868  
Dallas: (214) 392-7070

# THE LISP REVOLUTION

BY PATRICK H. WINSTON

*LISP is no longer  
limited to a lucky few*

A LITTLE MORE than five years ago, a friend from a major computer corporation came into my office to talk about developing artificial-intelligence (AI) packages. "How should we get started?" he asked. My answer was gloomy:

First, get together a million dollars or so and buy one of Digital Equipment Corporation's (DEC's) big mainframe computers. Next, decide what dialect of LISP to run, choosing from MacLISP, InterLISP, Portable Standard LISP, Franz LISP, and many others. Then try to get a tape from somewhere and find someone who can install it. You'll probably find that the documentation is not particularly complete, and software maintenance will be a problem. And if you bet on the wrong dialect now, changing to another will certainly take a lot of work.

Today, by contrast, I wrote this article using an editor written in LISP. The editor is part of a \$500 LISP system that I use on a \$4000 personal computer. I wrote and tested a program in the \$500 LISP that I will be able to

run without change on a supersophisticated, superpowerful Symbolics 3670. Two things have made this progress possible. First, the recent availability of personal computers with 512K bytes of memory, which is enough to learn LISP and to start experiencing the excitement of its applications in AI. Second, Common LISP emerged as the heir apparent to all previous LISP dialects. The same Common LISP program you write on a personal computer can be transferred later to a heftier machine, as needs and resources permit.

Data General, DEC, Hewlett-Packard, LISP Machine, Symbolics Inc., Texas Instruments, and Xerox all sell versions of Common LISP for their own machines, and Common LISP is available for personal computers as well. Suddenly, serious LISP programming is no longer limited to a lucky few.

## LISP MEANS SYMBOL MANIPULATION

The reason that LISP is different from most other languages is that LISP focuses on symbol manipulation rather than on numbers. To highlight the difference, I'll lay out some ex-

amples of symbol manipulation taken from the Mover program, one that moves toy blocks like those shown in figure 1. Specialized problem-solving procedures inside the Mover program enable it to get rid of obstacles that are in the way. These problem-solving procedures use and maintain information about what each object supports. For example, B3 supports B1 and B4. The Mover program knows this because the symbols B1 and B4 are found in a list obtained from B3 by the get instruction:

```
(get 'B3 things-supported)
-> (B1 B4)
```

Now suppose we have attached the list of things that B3 supports to a variable called obstacles. LISP's symbol-manipulation primitives allow for quick answers to basic questions:

```
How many obstacles are there?
(length obstacles) -> 2
```

(continued)

Patrick Henry Winston (MIT Artificial Intelligence Laboratory, 545 Technology Square, Cambridge, MA 02139) has a B.S., M.S., and Ph.D. from MIT. He does research on computer learning and directs the Artificial Intelligence Laboratory at MIT.



What's the first obstacle?  
 (first obstacles) —> B1  
 Is B1 an obstacle?  
 (member 'B1 obstacles) —> t  
 Is B4 the first obstacle?  
 (eq 'B4 (first obstacles)) —> nil

Note that t is LISP notation for true, and nil is LISP notation for false. Other symbol-manipulation primitives facilitate changes to the list and test to see if it is empty:

Remove B4 from the list:  
 (setf obstacles  
 (remove 'B4 obstacles)) —> (B1)  
 Add B7 to the list:  
 (setf obstacles  
 (cons 'B7 obstacles)) —> (B7 B1)  
 Is the obstacle list empty?  
 (endp obstacles) — NIL

Once changed, the obstacle list can be reattached to the symbol B3 from

which it came:  
 (setf (get 'B3 'things-supported)  
 obstacles)

All these questions and changes are simple, low-level examples of the symbol manipulation for which LISP is famous. Similar symbol-manipulation feats enable the Mover program to keep track of what is done. Mover's history-maintaining procedures contain instructions that examine and change symbolic expressions describing every move. Those symbolic descriptions make it possible to answer questions like: Did you move block B7? How did you move block B7? Why did you move block B7? When did you move block B7?

Thus symbol manipulation enables Mover to exhibit a humanlike, introspective ability to explain itself. Symbol manipulation is so intimately as-

sociated with AI, it's no wonder that LISP is the key language used in AI applications.

**COMPUTER PROFESSIONALS SHOULD KNOW LISP**

LISP experts argue endlessly about why LISP remains the primary language for AI and about why it is becoming a language for general-purpose programming as well. Some say LISP's primitives and features explain all. Others claim LISP owes its power to its tradition of interactive programming and powerful debugging tools. Still others cite its simple hierarchy-encouraging procedure-definition mechanism. [Editor's note: for a short introduction to LISP, see "LISP for the IBM Personal Computer" by Jordan Bortz and John Diamant, July 1984 BYTE, page 281.]

Increasingly, LISP is becoming a more generally used language, not strictly limited to applications in AI. Because many of the systems of AI are large, LISP has become a language suited to large-system implementation. For example, it has been used with outstanding success in building the entire operating systems of the LISP machines now offered by a growing number of major companies.

Such successes are one reason why many computer-science educators believe that an understanding of LISP is de rigeur for computer science majors. Another is that LISP has been proven an excellent language for illustrating computing concepts. At MIT, for example, a dialect of LISP called Scheme has been used for years as the primary language in the basic introductory subject on programming languages.

**LISP IS BOTH OLD AND NEW**

Before you learn any computer language, you should ask if the language is too old to be modern or too new to be mature. What about LISP? Is it too old or too new? Many people are surprised to learn that the history of LISP goes back to the late 1950s, making LISP nearly as old as FOR-

(continued)

Listing 1: A procedure found inside the Mover program illustrating the problem-reduction heuristic.

```
(defun put-at (object place) ;Define the PUT-AT procedure.
  (grasp object) ;Grasp the object—may require moving obstacles.
  (move-object) ;Move the object—easy.
  (ungrasp object)) ;Move the object—easy, too.
```

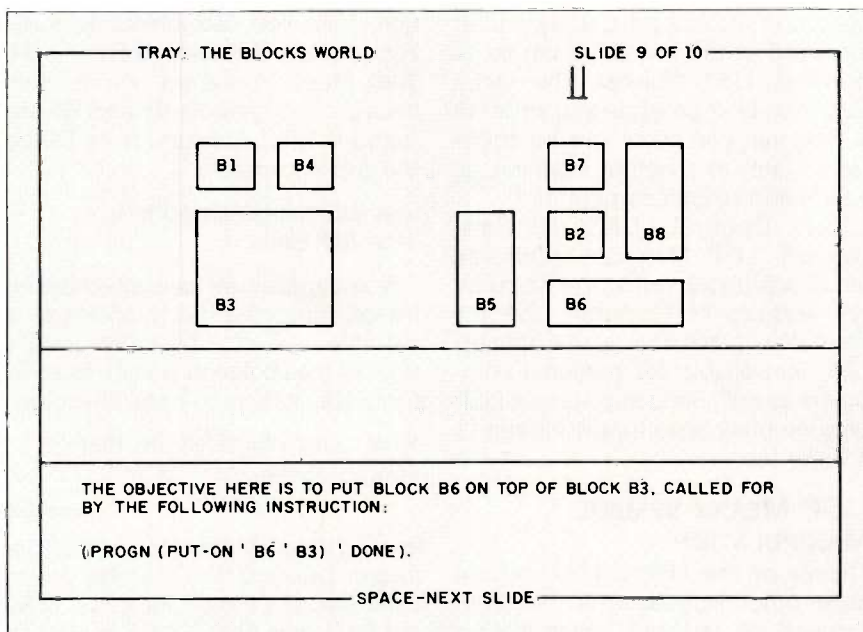

Figure 1: A picture of the blocks world in which the Mover program operates.

# LycO Computer Marketing & Consultants

"PEOPLE WHO KNOW WHAT THEY WANT AND KNOW HOW TO USE IT RECEIVE THE LOWEST PRICES AT LYCO"

## SAVE ON THESE IN-STOCK PRINTERS

**GEMINI 10X**  
\$219 ★

<b>MANNESMANN TALLY</b>		<b>Citoh</b>		<b>BLUE CHIPS</b>		<b>CARDCO</b>		<b>STAR MICRONICS</b>	
SPiRiT 80	\$255.00	PrOwriTer8510A	\$269	M12010	\$275	LQ1 Printer	379.00	Gemini 10x	\$219
MTL-160L	\$549.00	8510BC2	\$399	M12010 C-64	\$275	LQ3 Printer	299.00	Gemini 15x	\$345
MTL-180L	\$739.00	8510BP1	\$349	D4015	\$1389	C/76 C-64 Graphics	65.75	Delta 10	\$339
<b>JUKI</b>		8510SP	\$399	<b>OKIDATA</b>		C/7B C-64	39.75	Delta 15	\$449
Juki 6100	\$389	8510SR	\$409	Okimate 10	CALL	C/7AT Atari	55.00	Radix 10	\$499
Tractor Kit	\$119	8510SCP	\$419	82A	\$299	<b>Smith Corona</b>		Radix 15	\$589
<b>Epson</b>		8510SCR	\$499	83A	\$549	Fastext 80	189.00	Powertype	\$309
RX80	\$229	1550P	\$489	84	\$649	D100	219.00	Sweet P 100	\$549
RX80FT	\$269	1550BCD	\$539	92	\$349	D200	399.00	<b>PANASONIC</b>	
RX100	\$369	A10-20P	\$469	93	\$569	D300	519.00	1090	\$219
FX80	\$369	F1040PU or RDU	\$899	<b>LEGEND</b>		L1000	339.00	1091	\$259
FX100	\$555	F1055PU or RUD	\$1099	880	\$229.00	<b>Corona</b>		1092	\$415
JX80	\$1089	<b>DIGITAL DEVICES</b>		1000	\$279	LP300 Laser Printer	2699.	1093	\$599
LQ1500P(includes kit)	\$1149	16K printer buffer	99.75	1200	CALL	200361 Toner Cartridge	89.	3151	\$469
LQ1500S(includes kit)	\$529	32K printer buffer	119.75	1500	CALL	<b>NEC</b>		<b>PANASONIC</b>	
		64K printer buffer	169.95	1081	CALL	NEC 8025	\$699	<b>1091 \$259</b>	
						NEC 8027	\$359		

★ NOW STOCKING CITIZEN & OLIVETTIC PRINTERS ★

## MONITORS

## MODEMS

<b>TAXAN</b>		<b>AMDEK</b>	
210 Color RGB	255	300 Green	125
100 Green	115	300 Amber	145
105 Amber	125	310 Amber - IBM	159
400 Color RGB	295	Color 300-Audio	265
410 Color RGB	349	Color 500-Composite	379
420 Color IBM	449	Color 600	545
121 Green IBM	145	Color 700	635
122 Amber IBM	149	Color 710	675
<b>ZENITH</b>		<b>NEC</b>	
ZVM 122A Amber	86	JB 1260 Green	99.00
ZVM 1236 Green	82	JB 1201 Green	135.00
ZVM 124 Amber - IBM	129	JB 1205 Amber	145.00
ZVM 131 Color	275	JC 1215 Color	255.00
ZVM 133 RGB	389	JC 1216 RGB	399.00
ZVM 135 Composite	449	JC 460 Color	349.00
ZVM 136 Hi Res Color	589	<b>SAKATA</b>	
<b>GORILLA</b>		SC-100 Color	229
12' Green	\$ 82.00	STSI Tinstand	29
12' Amber	\$ 88.00	SG 1000 Green	99
		SA 1000 Amber	109

<b>NOVATION</b>		<b>ANCHOR</b>		<b>Hayes</b>	
J-Cat	\$89.00	Volksmodem	\$55.99	Smartmodem 300	\$199.00
Cat	\$129.00	Mark VII	\$95.99	Smartmodem 1200	\$469.00
Smart Cat 103/	\$169.00	(auto ans/dial)		Smartmodem 1200b	\$399.00
Smart Cat 103/212	\$389.00	Mark VII	\$259.00	Micromodem IIe	\$249.00
AutoCat	\$209.00	(1200 band)		Micromodem 100	\$289.00
212 Auto Cat	\$539.00	<b>TELELEARNING</b>		Chronograph	\$179.00
Apple Cat II	\$239.00	CM-250 Commodore 64	CALL	Westridge C-64	Call
212 Apple Cat	\$439.00	AP-250 Apple	CALL	Total	
Apple Cat 212	\$249.00	113-250 IBM	CALL	Telecommunications	
<b>MICROBITS</b>				C-64	Call
MPP1000C	\$109.00			Mitey Mo C-64	Call

## DISK DRIVES

<b>MSD</b>		<b>INDUS</b>	
SD1 DRIVE	\$259.00	GT ATARI	\$219.00
SD2 DRIVE	\$475.00	GT COMMODORE	\$249.00

## DISKETTES

## IBM-PC COMPATABLE

<b>MAXELL</b>		<b>ELEPHANT</b>	
5 1/4" MD-1	\$17.95	5 1/4" SSDD	\$14.99
5 1/4" MD-2	\$23.95	5 1/4" SSDD	\$16.99
<b>SKC</b>		<b>(Box 10)</b>	
(Box 10)		5 1/4" DSDD	\$21.99
SKC-SSDD	\$12.99		
SKC-SSDD	\$15.99		
SKC-DSDD	\$18.99		

<b>CORONA</b>		<b>Zenith</b>		<b>Microprose</b>	
PPC22A		Z-150	Call	Solo Flight	\$22.75
Portable 256K-Amber	\$1995	<b>Columbia Data</b>		NATO	\$22.75
PPC22G		1600	Call	<b>Graphics Tablet</b>	
Portable 256K-Green	\$1995	<b>Televideo</b>		Supersketch	\$49.95
PPCXTA		TS1605	Call	Kolala	\$99.95
Portable 256K-10Meg	\$3295	<b>Leading Edge</b>		Illustrator	\$99.95
COR128K 128K RAM	\$ 159	PC Compatible	Call	Logo Design	\$27.95
				Grams Spell	\$27.95

# TOLL FREE 1-800-233-8760



Inquiry 244

TO ORDER



CALL TOLL FREE

**800-233-8760**

or send order to  
LycO Computer  
P O Box 5088

Customer Service 1-717-327-1825 Jersey Shore PA 17740

### RISK FREE POLICY

In-stock item shipped within 24 hours of order. No deposit on C.O.D. orders. Free shipping on prepaid cash orders within the Continental U.S. PA residents add sales tax. APO, FPO, and International orders add \$5.00 plus 3% for priority mail service. Advertised prices show 4% discount for cash, add 4% for Master Card or Visa. Personal checks require 4 weeks clearance before shipping. All items subject to change without notice.

For your protection, we check for stolen credit cards.



TRAN. Unlike FORTRAN, however, the LISP of today is much different from the LISP of 25 or even 5 years ago. Why did FORTRAN calcify while LISP continued to evolve vigorously? The principal reason is that FORTRAN was suited to commercial applications early on, whereas LISP was not. LISP re-

quires a lot of memory, and in the days when memory was expensive, there was no commercial purpose served by early standardization of LISP. Consequently, LISP dialects proliferated, LISP innovations thrived, and cross-fertilizations from one dialect of LISP to another kept each

about as powerful as any other. Now, however, memory is relatively cheap, which is attracting many commercial users to LISP thus increasing the need for a standardized LISP for applications and instruction. Fortunately, the 25 years LISP has had to mature means that many new features have been incorporated into the Common LISP standard. Here are some of my favorites:

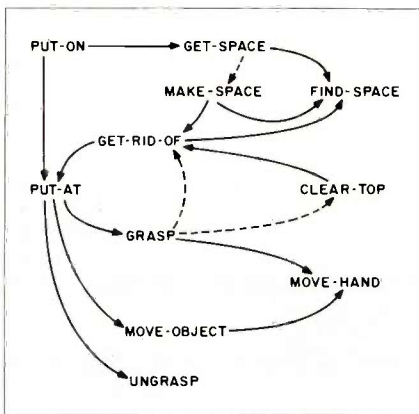

Figure 2: Graphical description of how all the procedures in Mover work together.

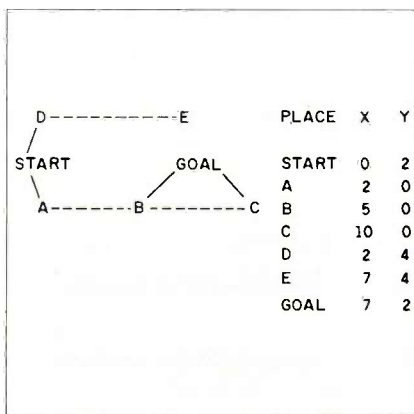

Figure 3: An example of a maplike net.

- a powerful structure-defining primitive that automatically generates procedures for accessing record fields
- a generalized assignment primitive that works for values, properties, arrays, and structures
- a flexible template-filling mechanism that enables complicated expressions to be constructed easily and transparently
- a strong macrocomputer capability that enables users to dream up their own syntax
- a rich variety of argument-passing options, including optional arguments with specifiable defaults as well as arguments associated with parameters by way of key words
- a modern, stream-oriented input/output (I/O) system

```
(make-rule identify16
  if ((> animal) is a (> type))
      ((< animal) is a parent of (> child))
  then ((< child) is a (< type)))
```

Figure 4: A rule ready for inclusion in a LISP-based animal-recognition system.

```
Rule IDENTIFY1 asserts (ROBBIE IS A MAMMAL)
  because (ROBBIE HAS HAIR)
Rule IDENTIFY5 asserts (ROBBIE IS A CARNIVORE)
  because (ROBBIE EATS MEAT)
Rule IDENTIFY9 asserts (ROBBIE IS A CHEETAH)
  because (ROBBIE HAS DARK SPOTS)
         (ROBBIE HAS TAWNY COLOR)
         (ROBBIE IS A CARNIVORE)
         (ROBBIE IS A MAMMAL)
Rule IDENTIFY16 asserts (BOZO IS A MAMMAL)
  because (ROBBIE IS A PARENT OF BOZO)
         (ROBBIE IS A MAMMAL)
Rule IDENTIFY16 asserts (BOZO IS A CARNIVORE)
  because (ROBBIE IS A PARENT OF BOZO)
         (ROBBIE IS A CARNIVORE)
Rule IDENTIFY16 asserts (BOZO IS A CHEETAH)
  because (ROBBIE IS A PARENT OF BOZO)
         (ROBBIE IS A CHEETAH)
```

Figure 5: Output fragment showing how a forward-chaining rule moves from facts to conclusion.

## HOW TO LEARN LISP

I think the best way to learn LISP is interactively. There are quite a number of reasons why such interactive learning is good. For instance: It's fun to do on-line puzzles; it's boring to do exercises in a book. It's easy to demystify difficult points by trying things out immediately. It's motivating to watch interesting programs work.

In any case, one factor stands undisputed: LISP programming is fun. Let's look at a few taken from an on-line, interactive instruction package known as the San Marco LISP Explorer. [Author's note: The San Marco LISP Explorer package is sold by Gold Hill Computers Inc., 163 Harvard St., Cambridge, MA 02139.] We will examine the Mover blocks-manipulation program, the rule-based ex-

(continued)

# It doesn't take much to make your programs run up to 20 times faster.

If you've been writing programs for your Commodore 64, Apple IIe or Apple IIc in BASIC you can take a giant step forward in speed of execution and in programming productivity for just \$49.95.

You can get program performance that you only thought possible from machine language programs. While still using a powerful, understandable high-level language. A language that's similar to Pascal, but much easier to learn and use.

You can create programs with our advanced, full-screen editor—much like you would on a word processor, and it even locates your compilation errors.

And when you compile your programs, you have a fast one-pass compiler, a recursive descent compiler that can compile a 100-line source program in 10 seconds or less.

PROMAL™ also gives you an elegant operating system "Executive," which includes powerful file, program and memory management commands and even I/O redirection.

You get all of that with PROMAL—improved programming productivity, faster compile and run time and power that you may never have thought possible.

**PROMAL—for the beginning or advanced programmer.**

Whether you are just beginning to write or are an experienced programmer, you can be more productive with PROMAL (PROgrammer's Micro Application Language). It's easier to learn than Pascal, C or Forth. It provides you with a full range of powerful structured statements like IF-ELSE, WHILE, REPEAT, FOR and CHOOSE. And, because indentation is part of the language's syntax, it helps you write programs neatly and logically. There are no line numbers to worry about, and since comments don't take up memory space, you can document your programs completely.

## COMMODORE 64 BENCHMARK

(Sieve of Eratosthenes)

	PROMAL	BASIC	COMAL	FORTH	PASCAL
Execution Time (secs.)	30	630	490	51	55
Object Code Size (bytes)	128	255	329	181	415
Program Load Time (secs.)	3.2	3.8	6.3	11.2	23.5
Compile Time (secs.)	8.5	—	—	3.9	108

### PROMAL—a language especially for small systems.

Unlike languages developed for larger systems and squeezed into small systems environments, PROMAL was conceived and developed specifically for the small system. With PROMAL there's finally a language created for the environment in which you work.

### Speed up your programs and step up your programming productivity.

You get all of that speed and productivity—with the PROMAL PM-200 "End-User" system (220 pages of

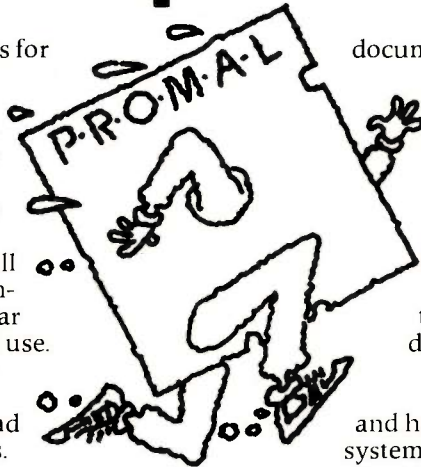

documentation and PROMAL system diskette including sample programs) for just \$49.95. There's a 15-day, no-risk moneyback guarantee. And the entire \$49.95 may be credited against later purchase of the "Developer's Version"

The "Developer's Version"—all the components of the "End User" system plus the "run time" object module generation capability, additional documentation and an unlimited right to sell or distribute PROMAL applications—is only \$99.95.

Or—for only \$10.00 plus \$2.50 postage and handling you can get the PM-100 demo system. It includes a 32-page manual and all the

## \$49.95 to be exact.

capabilities of the PM-200 except the ability to print or save

files to disk. It's a very inexpensive way to explore the wonders of PROMAL.

*Our Guarantee:* Try PROMAL for 15 days. If you are not completely satisfied, return it to us undamaged and we'll refund your money. No questions asked. Dealer inquiries invited.

For quicker response on credit card orders, call Toll Free:

# 1-800-762-7874

In NC: 919-787-7703.

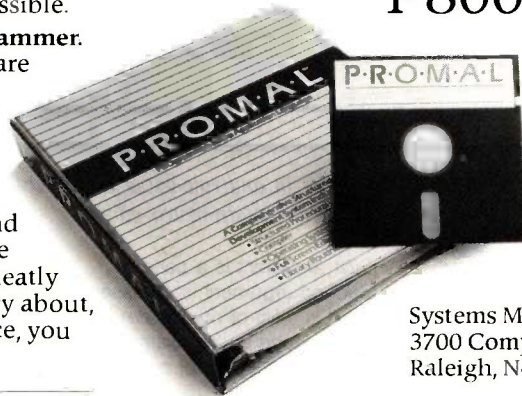

Systems Management Associates  
3700 Computer Drive, Dept. PB-3  
Raleigh, North Carolina 27609

### Order Form

Please send me my copy of PROMAL

My system is (check one):  Commodore 64  Apple IIe  Apple IIc  
PROMAL Package Desired (check one):

- PM-200 (for systems listed above) \$49.95 plus \$5.00 for shipping and handling for a total cost of \$54.95. Satisfaction Guaranteed.
- PM-300 Developer's Version \$99.95 plus \$5.00 for shipping and handling for a total cost of \$104.95. Satisfaction Guaranteed.
- PM-100 demo diskette \$10.00 for the diskette plus \$2.50 for postage and handling for a total cost of \$12.50. (Non-refundable.)
- My check is enclosed.  Please charge my purchase to my  Visa  Mastercard

Card Number \_\_\_\_\_ Expiration Date \_\_\_\_\_

Signature \_\_\_\_\_

Name \_\_\_\_\_

Address \_\_\_\_\_

City, State, Zip \_\_\_\_\_

North Carolina Residents add 4-1/2% sales tax.  
Foreign orders add \$15.00 additional shipping and handling.



Listing 2: A search program that finds paths through maplike nets such as the one in figure 3.

```
(defun start-depth (start goal))
  (depth (list (list start)) ;Make a one-partial-path queue.
         goal) ;Pass along name of goal place.

(defun depth (queue goal)
  ;;If no other partial paths, quit:
  (if (null queue)
      nil
      ;;Otherwise, if goal found, quit:
      (if (equal goal (first (last (first queue))))
          (first queue)
          ;;Otherwise, expand first partial path
          ;;and add to FRONT of queue:
          (depth (append (expand (first queue))
                        (rest queue))
                 goal))))))

(defun expand (path)
  (let ((reversed-path (reverse path)))
    ;;Turn the new partial paths right way around:
    (mapcar 'reverse
            ;;Get rid of partial paths that close on themselves:
            (remove-if '(lambda (new-path)
                        (member (first new-path) (rest new-path)))
                      ;;Make one new partial path for each neighbor:
                      (mapcar '(lambda (neighbor) (cons neighbor reversed-path))
                              ;;Get neighbors:
                              (get (first reversed-path) 'neighbors))))))
```

Listing 3: The expression-matching procedure in any rule-based expert system must compare expressions and produce a list of pattern-match pairs.

```
* (match '((> animal) is a (> type)) ;First argument is a pattern.
      ('(Robbie is a Cheetah)) ;Second argument is an assertion.
      nil) ;Third is a list of prior pattern-match
           ; pairs, none in this example.
((animal robbie) (type cheetah)) ;The answer—a list of pattern-matches.
```

Listing 4: A matcher program for a rule-based expert system.

```
(defun match (p d matches)
  (cond ((and (endp p) (endp d)) ;Succeed.
        (cond ((endp matches) t)
              (t matches)))
        ((or (endp p) (endp d)) nil) ;Fail.
        ((equal (first p) (first d)) ;Identical first elements.
         (match (rest p) (rest d) matches)) ;Match the rest.
        ((atom (first p)) nil) ;Losing atom.
        ((equal (first (first p)) '>) ;Match > variable.
         (match (rest p) (rest d)
                 (shove-value (second (first p))
                              (first d)
                              matches)))
        ((equal (first (first p)) '<) ;Substitute variable.
```

(continued)

pert system, and the natural-language interface.

### PLANNING IN THE BLOCKS WORLD

LISP programs are generally examples of the problem-reduction heuristic: that is, to solve a hard problem you must break it up into simpler subproblems. The problem-reduction heuristic can be seen in the simple Mover program. Listing 1 is a procedure found inside the Mover program that breaks the problem of putting an object somewhere into three subproblems: grasp it, move it, and ungrasp it. Figure 2 is a graphical description of how all of the procedures in Mover work together. LISP encourages the creation of layered programs, like Mover, wherein big problems are broken down successively into smaller and smaller problems.

### SEARCHING IN THE MAP WORLD

Search techniques are commonly used in AI to solve problems. Here are some examples:

- finding a route through a highway net
- finding a way to put together a motor
- understanding a written database request
- learning to recognize a plant disease

Abstractly, search problems all amount to finding a way through some sort of maplike net. Figure 3 is a sample of such a net. The goal is close to place E, but there is no direct connection; E is a dead end. There are two ways to go from B to the goal: directly, and indirectly, through C. Listing 2 shows a page of LISP defining a search program that finds paths through these maplike nets. Although you won't understand much of the program if you don't know LISP yet, you may enjoy looking at its overall structure and simplicity. With a little more effort, you can define a search

(continued)





## ALL AIRLINES DEPART FROM THIS TERMINAL.

### Presenting Travelshopper<sup>SM</sup> ...new from CompuServe and TWA.

Now you can save time and money by getting information and reservations on virtually any flight on any airline—worldwide—from one source. It's TWA's new Travelshopper, available now through CompuServe's Information Service.

With Travelshopper, you scan flight availabilities, discover airfare bargains and order tickets...on your own personal computer...at home or in the office.

You also receive automatic membership in TWA's Frequent Flight Bonus<sup>SM</sup> program. And you can build bonus points by staying at Marriott and Hilton hotels and by using Hertz Rent-A-Car.

Besides Travelshopper, CompuServe

offers an ever-growing list of other travel-oriented on-line services.

**The Official Airline Guide Electronic Edition** lists direct and connecting flight schedules for over 700 airlines worldwide plus over 500,000 North American fares.

**A to Z Travel/News Service** gives complete information for over 20,000 hotels worldwide plus latest travel news.

**Discover Orlando** provides complete prices, hours and features on all of Central Florida's attractions and accommodations.

**West Coast Travel** offers travel information for the western states.

**Pan Am's Travel Guide** contains up-to-date information on immigration

and health requirements for most foreign countries.

And TravelVision<sup>®</sup> provides complete automotive information including road maps and personalized routing service.

Let your travel plans really take off. Use Travelshopper and lots, lots more from CompuServe.

To buy a CompuServe Starter Kit, see your nearest computer dealer. To receive our informative brochure, or to order direct, call or write:

## CompuServe

P.O. Box 20212, 5000 Arlington Centre Blvd.,  
Columbus, Ohio 43220

**1-800-848-8199**

In Ohio, Call 1-614-457-0802

Inquiry 77



```
(match (cons (pull-value (second (first p) matches)
                    (rest p))
            d
            matches))))
```

This matcher happens to use two auxiliary procedures:

```
(defun pull-value (variable a-list)
  (second (assoc variable a-list)))

(defun shove-value (variable item a-list)
  (append a-list (list (list variable item))))
```

Listing 5: A program that matches sentences against a suitable representation of semantic grammars and activates the appropriate search procedure.

```
(record question
  ((branch ((parse present)
            (branch (THE (parse attributes) OF (parse tools)
                    (parse-result-if-end
                     (report-attributes attributes tools)))
                ((parse tools) S (parse attributes)
                 (parse-result-if-end
                  (report-attributes attributes tools))))))
   (HOW MANY METERS IS (parse tool1) FROM (parse tool2)
    (parse-result-if-end
     (report-distance tool1 tool2)))
   (IDENTIFY (parse tools)
    (parse-result-if-end
     (report-identity tools)))
   (COUNT (parse tools)
    (parse-result-if-end
     (report-number tools)))))
```

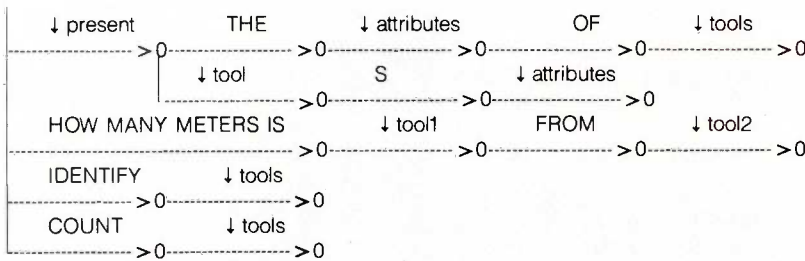

Figure 6: The top level of a semantic grammar capable of handling queries about the color, weight, length, and position of some tools.

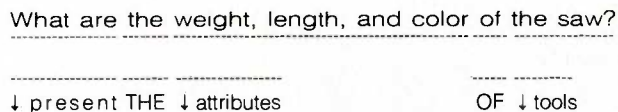

Figure 7: An example of a question that matches the top level of the semantic grammar in figure 6.

procedure that finds the guaranteed-shortest path.

### ANALYSIS IN THE ZOO WORLD

Rule-based expert systems are the hottest thing in the commercialization of AI. All of them are built on the idea that some kinds of knowledge can be reduced to simple rules. Figure 4 shows one rule that is ready for inclusion in a LISP-based animal-recognition system, which expresses the fact that an animal's children are animals of the same kind. LISP does not have any built-in primitives that handle such rules, but it is a splendid language in which to embed a rule-exploiting program. LISP's symbol-manipulating power is well suited to the task of examining the symbols that make up a rule, comparing them to the symbols that make up the existing facts, and reacting accordingly. One kind of rule-exploiting program is a forward-chaining rule interpreter, which is a program that uses rules to move forward from facts to conclusions. Figure 5 is an output fragment showing what such a program does with facts about Robbie, knowledge about the relationship between Robbie and Bozo, and a few rules. There is always an expression-matching procedure buried inside any rule-based expert system like the animal-identification procedure. While the entire system is too lengthy to show, the matcher is short and straightforward. Its task is to compare expressions and to produce a list of pattern-match pairs, as shown in listing 3. Listing 4 is the matcher program.

### INTERACTION IN THE TOOL WORLD

The pattern matcher shown previously is not just an important part of a rule-based system. It is also just about all you need to make the famous Doctor program, the one that pretends it is a psychiatrist responding with apparent sympathy as you pour your heart out over family traumas. More importantly, the pattern matcher has a family resemblance to natural-lan-

(continued)

# MicroAge®



## Join The Leader

### ...and be a Leader!

MicroAge is the computer solution leader. Throughout the United States and Canada, businesspeople rely on MicroAge for advice, leading products, and service when computerizing their companies.

But remaining the leader takes talented professionals who are willing to invest in their own community. People who are willing to assume a leadership position. That's why MicroAge is meeting with indi-

viduals who want to own and operate a MicroAge sales organization.

Owning a MicroAge franchise is more than running a store. We sell multi-user systems, local area networks and telephone systems... along with personal computers. We provide service, installation and training for our customers.

If you would like to develop a long-term relationship serving the businesses in your area, let's talk business! Call or write:

**MicroAge®**  
**COMPUTER STORES**  
*"The Solution Store"®*

1457 West Alameda • Tempe, AZ 85282  
1-800-245-4683

In Arizona or outside the continental U.S. call (602) 968-3168

**"The Leader In Multi-User Technology"**



gauge interface programs built on what is called a semantic grammar. Basically, a semantic grammar is a model of what can be said in tightly constrained conversations about a narrow database. Suppose that you are interested in the color, weight, length, number, and position of some tools. The natural queries are:

- Identify the hammers.
- Count the red screwdrivers.
- Show me the color of the wrenches.
- Present the small red screwdriver's weight.
- What is the length and weight of the large saw?
- How many meters is the small red screwdriver from the big blue

screwdriver from the big blue one?

The top level of a semantic grammar capable of handling all these queries is shown in figure 6. A semantic-grammar interpreter finds paths through such a net using input sentences as a guide. Each branch marked with a > symbol requires traversal of a subnet. Each complete path from the entry to an exit is associated with its own data-searching procedure. For example, the sentence in figure 7 matches the top-most path in the top-level net. Three subnets are traversed in addition to the top-level net. Once again, LISP's symbol-manipulating power makes it easy to write a program that both matches sentences against a suitable representation of semantic grammars and activates the appropriate search procedures. Listing 5 shows what such a representation looks like when it is rendered in LISP-oriented notation.

**CONCLUSION**

We really don't need any new examples to demonstrate why professionals need to know about LISP. The examples presented are all elementary, but they indicate the sorts of things done by their bigger brothers. LISP is the foundation for expert systems of all kinds, many of which have progressed far beyond the simple rule-based paradigm. LISP is the language for most natural-language development efforts. Indeed, LISP is the language of choice for most people working in AI—supporting work that includes learning, instruction, speech, vision, robotics, and all sorts of reasoning. ■

**BIBLIOGRAPHY**

Abelson, Harold, and Gerald Jay Sussman. *Structure and Interpretation of Computer Programs*. Cambridge, MA: MIT Press, 1984.  
 Winston, Patrick H. *Artificial Intelligence*. 2nd ed. Reading, MA: Addison-Wesley, 1984.  
 Winston, Patrick H., and Berthold K. P. Horn. *LISP*, 2nd ed. Reading, MA: Addison-Wesley, 1984.  
 Winston, Patrick H., and Karen A. Prendergast. *The AI Business: The Commercial Uses of Artificial Intelligence*. Cambridge, MA: MIT Press, 1984.

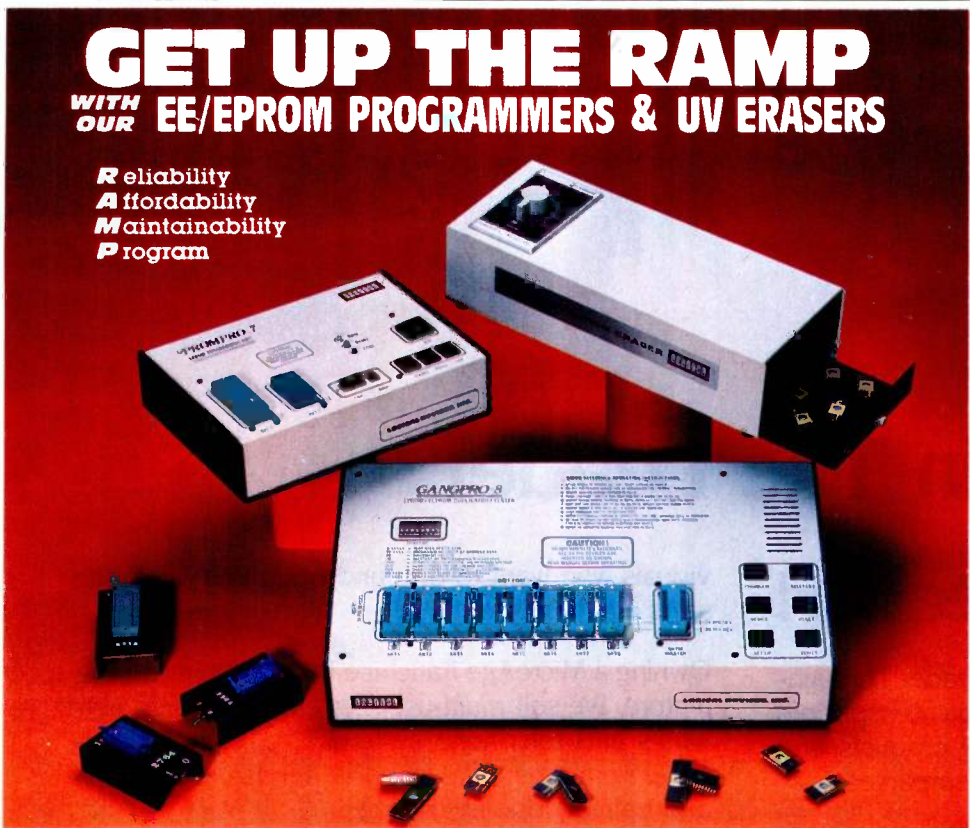

Choose from our **Stand Alone, Intelligent, RS-232 units.**  
 COMPATIBLE WITH ANY COMPUTER OR TERMINAL.

**GANGPRO-8 . . . . . \$995.00**

High throughput. Gang 8 EPROMS with the fast Algorithm. Optional 512K buffer. Programs ALL 24 pin & 28 pin EPROMS. Other units to gang 24 EPROMS.

**PROMPRO-8 . . . . . \$689.00**

Powerful commands, easy communications, 128/256K buffer. Alpha Display. Simulation and Keypad option. Programs ALL EPROMS & MPU's.

**PROMPRO-7 . . . . . \$489.00**

32K RAM buffer, ideal for programming 8748, 8749, other Intel MPU's and 16K-128K EPROMS.

**BIPOLAR & PAL Programmiers...Call!**

TELEX 383 142



**UV ERASERS**

**ECONOMY MODEL QUUV-T8/1 . . . . \$49.95**  
 Erases over 15 EPROMS. Plastic case.

**INDUSTRIAL QUUV-T8/2N . . . . . \$68.95**  
 Metal case, UV indicator, tray, erases over 15 EPROMS in 15 minutes.

**INDUSTRIAL QUUV-T8/2T . . . . . \$97.50**  
 With 60 minute timer and safety switch.

**INDUSTRIAL QUUV-T8/2Z . . . . . \$124.95**  
 Fast Eraser. 15 EPROMS in 7 minutes. 30 EPROMS in 15 minutes.

**PRODUCTION UNIT . . . . . \$149.95**  
 Model: ULTRA-LITE™ Erases 50 EPROMS in 15 minutes.

TOLL FREE **1-800-EE1-PROM**  
 (331-7766) · FLORIDA (305) 974-0967

**AVAILABLE SOFTWARE DRIVERS**

- |                 |                |                |        |
|-----------------|----------------|----------------|--------|
| 1 IBM PC        | 2 APPLE II     | 3 Intel-MDS    | 4 CPM  |
| 5 TEXTRONIX8002 | 6 COMMODORE 64 | 7 TRS-80 COLOR | 8 FLEX |

**LOGICAL DEVICES, INC.**

DEPT. 6, 1321-E N.W. 65th PLACE · FT LAUDERDALE, FL 33309  
 DISTRIBUTORS INQUIRY WELCOME

# Systems Programmers and Programmer/Analysts EDS Wants To Challenge Your Talents.

## THE EDS AND GM ALLIANCE HAS CREATED A TECHNICAL ARENA THAT OTHER COMPANIES CAN ONLY ENVY.

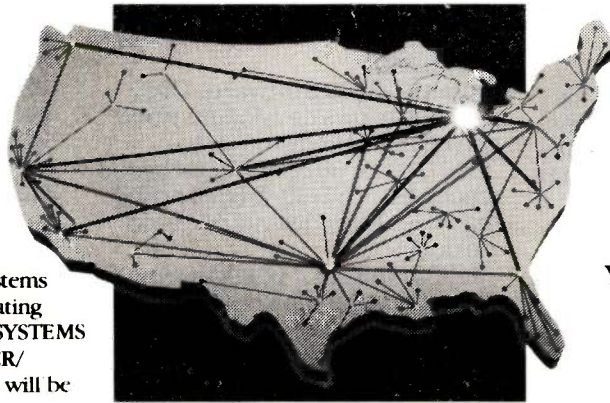

The alliance of Electronic Data Systems (EDS) and General Motors is creating major career opportunities. As a SYSTEMS PROGRAMMER or PROGRAMMER/ANALYST, your skills and abilities will be challenged.

EDS is offering you IMMEDIATE opportunities to enjoy hands-on experience with truly state-of-the-art hardware and software. This state-of-the-art experience will ensure that your skills are kept as current as possible. Also, EDS offers training programs that have become models for the industry and are geared to prepare you for the performance that ensures success. As one of IBM's largest customers and one of the nation's largest hardware users, EDS is creating one of the most automated work environments in the business world today. This is your once-in-a-career opportunity to become involved in the leading edge of technology.

### EDS AND GM ARE PIONEERING TECHNOLOGY. AND SO CAN YOU.

EDS and GM are world-renowned leaders in technology. EDS ensures this leadership by continually upgrading our facilities with the most advanced hardware and software available. And since we employ components that accommodate change, our operating

systems are never limited by technology of the past. You benefit as a professional since you will never be hindered by out-of-date equipment. The best technology of tomorrow is built on the best technology of today. And that's all you find at EDS.

### SYSTEMS PROGRAMMERS AND PROGRAMMER/ANALYSTS: OUTSTANDING CAREER OPPORTUNITIES.

We have IMMEDIATE career opportunities for professionals who are interested in moving the industry onward. If you are a SYSTEMS PROGRAMMER with two years experience in an IBM, IBM-compatible or DEC/VAX environment with a solid working knowledge of ALC or ASSEMBLER, we have challenges in the areas of VTAM, VM, IMS, IDMS, and MVS. If you are a Programmer/Analyst with two years experience in an IBM or IBM-compatible environment with a solid working knowledge of COBOL, PL/1 or ALC, EDS has the ideal environment to challenge your skills.

### YOUR CAREER GROWTH: AT EDS, WE DON'T TAKE YOUR TALENT FOR GRANTED — WE CHALLENGE IT, WE RESPECT IT AND WE NURTURE IT.

EDS knows that new ideas and new technology are only as good as the people who create them. That's why developing the potential of our employees is a continuing priority. We believe our strength is enhanced when our employees develop new skills and accept greater responsibilities. Therefore, we have created an environment that lets you build your future by the knowledge and skills you acquire — not by rank or seniority. At EDS, you control your own future.

Act now, advance the industry while experiencing the technological challenges and advantages EDS can offer you. Send your resume in confidence to:

ELECTRONIC DATA SYSTEMS  
CORPORATION  
755 W. Big Beaver  
Suite 310, Dept. 08-0485-39  
Troy, MI 48084

# EDS

## Electronic Data Systems Corporation

An Equal Opportunity Employer.



# Super assemblers plus the world's largest selection of cross assemblers!

## Z-80 Macroassembler

**Power for larger programs!** This 2500AD macroassembler includes:

- Zilog Z-80 Macroassembler (with the same powerful features as all our assemblers)
- powerful linker that will link up to 128 files. Com files may start at any address
- Intel 8080 to Zilog Z-80 Source Code Converter (to convert all your Intel source to Zilog Syntax in one simple step)
- COM to Hex Converter (to convert your object files to Hex for PROM creation, etc.)
- 52 page User Manual

## 8086/88 Assembler with Translator

**Available for MSDOS, PCDOS, or CPM/86!** This fully relocatable macro-assembler will assemble and link code for MSDOS (PCDOS) AND CPM/86 on either a CPM/86 or MSDOS machine. This package also includes:

- An 8080 to 8086 source code translator (no limit on program size to translate)
- A Z-80 to 8086 translator
- 64 page user manual
- 4 linkers included:
  - MSDOS produces .EXE file
  - CPM/86 produces .CMD file
  - Pure object code generation
  - Object code and address information only

Linker features:

- Links up to 128 files
- Submit mode invocation
- Code, Data Stack and extra segments
- Handles complex overlays
- Written in assembly language for fast assemblies.

## Z-8000 Cross Development Package

**Instant Z-8000 Software!** This package allows development and conversion of software for the Z8001, 8002, 8003 and 8004 based machines on a Z-80, Z-8000 or 8086 machine. This powerful package includes:

- a Z-80/8080 to Z-8000 Assembly Language Source Code Translator
- Z-8000 Macro Cross Assembler and Linker

The Translators provide Z-8000 source code from Intel 8080 or Zilog Z-80 source code. The Z-8000 source code used by these packages are the unique 2500AD syntax using Zilog mnemonics, designed to make the transition from Z-80 code writing to Z-8000 easy.

## All 2500 AD Assemblers and Cross Assemblers support the following features:

**Relocatable Code** — the packages include a versatile Linker that will link up to 128 files together, or just be used for external reference resolution. Supports separate Code and Data space. The Linker allows Submit Mode or Command Invocation.

**Large File Handling Capacity** —the Assembler will process files as large as the disk storage device. All buffers including the symbol table buffer overflow to disk.

**Powerful Macro Section**— handles string comparisons during parameter substitutions. Recursion and nesting limited only by the amount of disk storage available.

**Conditional Assembly**—allows up to 248 levels of nesting.

## Assembly Time Calculator—

will perform calculations with up to 16 pending operands, using 16 or 32 Bit arithmetic (32 Bit only for 16 Bit products). The algebraic hierarchy may be changed through the use of parentheses.

**Include files supported— Listing Control**—allows listing of sections on the program with convenient assembly error detection overrides, along with assembly run time commands that may be used to dynamically change the listing mode during assembly.

**Hex File Converter, included** —for those who have special requirements, and need to generate object code in this format.

## Cross reference table generated— Plain English Error Messages—

System requirements for all programs: Z-80 CP/M 2.2 System with 54k TPA and at least a 96 column printer is recommended. Or 8086/88 256k CP/M-86 or MSDOS (PCDOS).

## Cross Assembler Special Features

**Z-8**—User defined registers names, standard Zilog and Z-80 style support. Tec Hex output option.

**8748**—standard Intel and Z-80 style syntax supported.

**8051**—512 User defined register or addressable bit names.

**6800 Family**—absolute or relocatable modes, all addressing modes supported. Motorola syntax compatible. Intel Hex or S-Record format output.

**6502**—Standard syntax or Z-80 type syntax supported, all addressing modes supported.

	Z80 CP/M®	ZILOG SYSTEM 8000 UNIX	IBM PC MSDOS	IBM PC CP/M 86	OLIVETTI M-20 PCOS
Z8000™	\$299.50	\$750.00	\$299.50	\$299.50	\$299.50
Z80	99.50	500.00	199.50	199.50	199.50
Z8	199.50	500.00	199.50	199.50	199.50
8086/88	199.50	750.00	99.50	99.50	199.50
80186	199.50	750.00	199.50	199.50	199.50
8748	199.50	500.00	199.50	199.50	199.50
8044/51	199.50	500.00	199.50	199.50	199.50
8080	199.50	500.00	199.50	199.50	199.50
8085	199.50	500.00	199.50	199.50	199.50
8096	199.50	500.00	199.50	199.50	199.50
68020	399.50	750.00	399.50	399.50	399.50
68000,08,10	299.50	750.00	299.50	299.50	299.50
6800,02,08	199.50	500.00	199.50	199.50	199.50
6801,03	199.50	500.00	199.50	199.50	199.50
6804	199.50	500.00	199.50	199.50	199.50
6805	199.50	500.00	199.50	199.50	199.50
6809	199.50	500.00	199.50	199.50	199.50
32000	399.50	750.00	399.50	399.50	399.50
COPS400	199.50	500.00	199.50	199.50	199.50
NSC800	199.50	500.00	199.50	199.50	199.50
6301	199.50	500.00	199.50	199.50	199.50
6501/11	199.50	500.00	199.50	199.50	199.50
6502	199.50	500.00	199.50	199.50	199.50
65C02	199.50	500.00	199.50	199.50	199.50
1802	199.50	500.00	199.50	199.50	199.50
F8/3870	199.50	500.00	199.50	199.50	199.50
NEC7500	199.50	500.00	199.50	199.50	199.50
NCR/32	399.50	750.00	399.50	399.50	399.50

Subtotal \$ \_\_\_\_\_ \$ \_\_\_\_\_ \$ \_\_\_\_\_ \$ \_\_\_\_\_ \$ \_\_\_\_\_

Name \_\_\_\_\_  
Company \_\_\_\_\_  
Address \_\_\_\_\_  
City \_\_\_\_\_ State \_\_\_\_\_ Zip \_\_\_\_\_  
Phone \_\_\_\_\_  
Make and model of computer system \_\_\_\_\_  
 COD (2500AD pays COD charges)  
 VISA or MasterCard  
Number \_\_\_\_\_  
Expiration Date \_\_\_\_\_

**TO ORDER.** Simply circle the product or products you want in the price columns, and add up your order.

**Check one:**  
 8" Single  
 Osborne  
 IBM PC  
 Cartridge tape  
 Apple (Softcard)  
 Kaypro DSDD  
other formats available, please call!

Shipping UPS Blue Label no charge, \$15.00 International per unit \$ \_\_\_\_\_

**Total \$** \_\_\_\_\_  
**Total Order \$** \_\_\_\_\_

Signature \_\_\_\_\_

220



P.O. Box 4957, Englewood, CO 80155, (303) 790-2588 TELEX 752659/AD



# HOW TO BUY SOFTWARE WHEN ALL THE ADS LOOK THE SAME.

**W**e know it's hard to choose a software house. All the ads say the same thing—"Lowest prices," "fastest delivery," "best support," "biggest inventory."

Trouble is, although the claims are the same, the companies are very different. Which is why we want you to know some important facts about us:

**1.** 800-SOFTWARE is one of the oldest and most reputable firms in the industry. Our customers include IBM, GE, Hewlett-Packard, Xerox, AT&T, and thousands of other satisfied buyers.

**2.** Our National Accounts Program offers volume discounts and valuable services to large software users. We offer *incredibly* low prices on large bids!

**3.** We have a giant, \$1,000,000 inventory. Which means we can offer next-day delivery if needed.

**4.** With every product you get friendly, expert technical support. Have a question? You'll be glad you bought from 800-SOFTWARE!

**5.** We'll match our competitors' prices on most products. We *never* cut service.

**6.** We never charge extra for credit card purchases, nor do we process for payment until the product is shipped. (Our competitors don't make this claim!)

**7.** You'll automatically receive our Technical Support Newsletter—a great way to stay up-to-date.

**8.** We are members of the Better Business Bureau and the Direct Marketing Association.

**9.** We want your business. *And* your repeat business. Which is why we work so hard to keep you happy. Give us a call and let us *prove* it!

## CHECK OUT ALL OUR INCREDIBLE PRICES:

Lotus 1-2-3 \$295	dBase II/III \$259/\$349	Framework \$349	WordStar 2000/2000 Plus CALL
Lotus Symphony \$425	Crosstalk \$95	PFS File/Graph/Write \$84	IUS Accounting \$299/mod.
<b>SOFTWARE</b>		<b>MICROPRO®</b>	
ASHTON-TATE™		WordStar	\$209
dBase II/III	\$259/\$349	WordStar 2000/2000 Plus	CALL
Framework	\$349	WordStar Pro Package/P.P. Plus	\$259/\$359
<b>BORLAND SOFTWARE™</b>		InfoStar	CALL
Sidekick	CALL	All Other Products	CALL
Turbo Pascal/8087	\$39/\$79	<b>MICRODIM™</b> RBase 4000	\$259
<b>BOURBAKI™</b> 10ir	\$ 79	<b>MICROSOFT®</b>	
<b>DECISION RESOURCES™</b>		Multiplan	\$125
Chartmaster	\$249	Word w/Mouse	\$299
Signmaster	\$189	Fortran	\$269
<b>DIGITAL RESEARCH™</b>		All Other Products	CALL
<b>FOX &amp; GELLER™</b>	CALL	<b>MICROSTUF™</b> Crosstalk	\$ 95
<b>FUNK SOFTWARE™</b> Sideways	\$ 49	<b>MULTIMATE™</b>	\$255
<b>HARVARD SOFTWARE™</b>		<b>NORTON UTILITIES™</b>	\$ 59
Harvard Project Manager	\$289	<b>ROSESOFT™</b> Pro Key	\$ 99
IMSI™ PC Paintbrush	\$ 99	<b>SOFTWARE PUBLISHERS™</b>	
<b>LIFEBOAT™</b> LATTICE C COMPILER	\$359	PFS File/Graph/Write	\$ 84
<b>LIFETREE™</b> Volkswriter Deluxe	\$179	PFS Report	\$ 75
<b>LOTUS™</b>		<b>SORCIMI/US™</b>	
1-2-3	\$295	SuperCalc 2/3	\$159/\$195
Symphony	\$425	EasyWriter II System	\$185
		<b>IUS Easy Business Accounting</b> \$299/mod.	
		Super Project \$209	
		All Other Products CALL	
		<b>HARDWARE, ETC</b>	
		<b>AMDEK™</b> Monitors CALL	
		<b>AST™</b> Products CALL	
		<b>ATI™ &amp; CDEX™</b> TRAINING CALL	
		<b>CODE-A-PHONE™</b> Tel-A-Modem \$479	
		<b>EPSON™</b> PRINTERS NEW LOW PRICES!	
		<b>HAYES™</b>	
		Smartmodems 1200/1200B CALL	
		<b>HERCULES™</b>	
		Color Card \$199	
		Graphic Card \$325	
		<b>MAXELL™ &amp; MEMOREX™</b> DISKETTES CALL	
		<b>MEMORY CHIPS</b> CALL	
		<b>OKIDATA™</b> PRINTERS NEW LOW PRICES!	
		<b>PRINCETON GRAPHICS™</b> MONITORS CALL	
		<b>QUADRAM™</b> CALL	
		<b>WESTERN UNION EASY LINK®</b> FREE	

## WE ALSO CARRY HUNDREDS OF OTHER PRODUCTS!



800-SOFTWARE, INC.  
940 Dwight Way  
Berkeley, CA 94710



To order call toll-free:

**800-227-4587 OR 415-644-3611**

- Dealer inquiries welcome.
- Quantity discounts available through our National Accounts Program.
- Purchase orders accepted. Please call us in advance.
- Call for shipping charges. Overnight delivery available.
- We do not add surcharge for credit card purchases.
- Prices may change. Above prices are for IBM-PC and compatibles.
- International orders welcome: TELEX #751743 800 SOFTWARE UD.

# THE CHALLENGE OF OPEN SYSTEMS

BY CARL HEWITT

*Current logic programming methods may be insufficient  
for developing the intelligent systems of the future*

SYSTEMS OF INTERCONNECTED and interdependent computers are qualitatively different from the relatively isolated computers of the past. Such "open systems" uncover important limitations in current approaches to artificial intelligence (AI). They require a new approach that is more like organizational design and management than current approaches. In this article we'll take a look at some of the implications and constraints imposed by open systems.

Open systems are always subject to communications and constraints from outside. They are characterized by the following properties:

- *Continuous change and evolution.* Distributed systems are always adding new computers, users, and software. As a result, systems must be able to change as the components and demands placed upon them change. Moreover, they must be able to evolve new internal components in order to accommodate the shifting work they perform. Without this capability, every system must reach the point where it can no longer expand to accommo-

date new users and uses.

- *Arm's-length relationships and decentralized decision making.* In general, the computers, people, and agencies that make up open systems do not have direct access to one another's internal information. Arm's-length relationships imply that the architecture must accommodate multiple computers at different physical sites that do not have access to the internal components of others. This leads to decentralized decision making.

- *Perpetual inconsistency among knowledge bases.* Because of privacy and discretionary concerns, different knowledge bases will contain different perspectives and conflicting beliefs. Thus, all the knowledge bases of a distributed AI system taken together will be perpetually inconsistent. Decentralization makes it impossible to update all knowledge bases simultaneously. This implies that it is not even possible to know what kinds of information are contained in all the local knowledge bases in the system at any one time. Systems must be able to operate in the presence of inconsistent and incomplete knowledge bases.

- *Need for negotiation among system components.* In a highly distributed system, no system component directly controls the resources of another. The various components of the system must persuade one another to provide capabilities. Consequently, a distributed AI system's architecture must support a mechanism for negotiation among components.

- *Inadequacy of the closed-world assumption.* The closed-world assumption is that the information about the world being modeled is complete in the sense that exactly those relationships that hold among objects can be derived from the local information possessed by the system. Systems that depend on the closed-world assumption make use of the principle that they can find

*(continued)*

Carl Hewitt received his Ph.D. from the Massachusetts Institute of Technology in 1971 and since then has worked in the field of artificial intelligence on foundational issues. His outside interests include hiking and skiing. Professor Hewitt can be reached at the MIT Artificial Intelligence Laboratory, 545 Technology Square, Room 813, Cambridge, MA 02139.



all existing instances of a concept by searching their local storage. At first glance it might seem that the closed-world assumption, almost universal in the AI literature, is smart because it provides a ready default answer for any query. Unfortunately, the default answers provided become less realistic as open systems increase in size and less of the information is available locally.

Continuous growth and evolution, arm's-length relationships, inconsistency among knowledge bases, decentralized decision making, and the need for negotiation are interdependent and necessary properties of open systems.

**PARALLEL COMPUTATION IN OPEN SYSTEMS**

The theory of recursive functions (e.g., Turing machines) is based on a batch-processing model of computation. Output is obtained from a recursive function when it finally halts. Open systems require a theory of computation in which processing might never halt, may be required to provide output while still in operation, and can accept input from sources not anticipated when the computation began.

Asynchronous parallel computer systems make use of a two-input, two-output computing element called an *arbiter*. Arbiters are the fundamental hardware primitives that make parallel asynchronous computing different from sequential synchronous computing. Arbiters make decisions for which there is no logical justification (proof) because the decision cannot be predicted from knowledge of the structure of the computing system and its input. In a very fundamental sense, arbiters are not equivalent to Turing machines (see reference 3). Figure 1 shows an arbiter with inputs *x* and *y* and outputs *x'* and *y'*.

An arbiter decides the order in which it receives requests. Thus, if inputs *x* and *y* are asserted at about the same time, the result will eventually be one of the possibilities shown in figure 2.

The output of an arbiter is *not* a

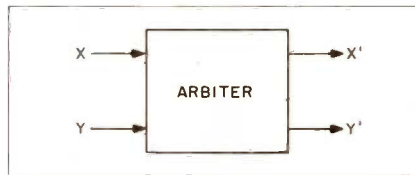

Figure 1: An arbiter, with inputs *x* and *y* and outputs *x'* and *y'*.

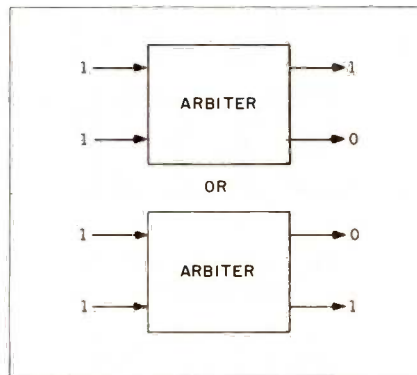

Figure 2: Given that the inputs to the arbiter are asserted almost simultaneously, the resulting output will be one of the above two cases.

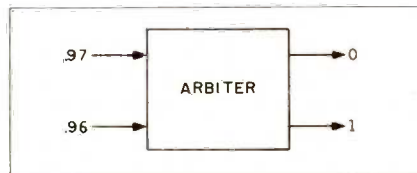

Figure 3: In practice, the inputs to an arbiter are analog signals varying between 1 and 0.

logical function of its input, in the sense that it is not a simple Boolean function, because the dimension of time enters into the semantics of arbiter modules in a fundamental way. However, the *feasible* sets of outputs can be described in logic using the *subsequently* relation (see reference 1):

$$(x=1 \text{ and } y=1) \text{ subsequently} \\ \text{(or)} \\ (x'=0 \text{ and } y'=1) \\ (x'=1 \text{ and } y'=0)$$

Logic cannot be used to determine which particular eventuality will occur. Systems with arbiters are not equivalent to a nondeterministic Turing

machine, since an arbiter can require an unbounded amount of time to make a decision (possibly while other computations are taking place). If a nondeterministic Turing machine is required to make a decision, there is a bound on the amount of time it can take, and this bound is determined before it starts. Each individual choice of a nondeterministic Turing machine takes one step.

In practice, the inputs to an arbiter are analog signals that vary continuously between 0 and 1. For example, if the actual inputs to an arbiter were .97 and .96, then the output might be as shown in figure 3.

The arbiter has only digital outputs (0s or 1s) even though the input is analog. It makes a definite digital choice out of the analog quantities of time and its two inputs. Because of the continuous nature of time and the analog nature of the input, an arbiter cannot be strictly modeled as a nondeterministic-state machine.

In a parallel computation, arbiters are used repeatedly so that the number of possible outcomes grows exponentially with time. Thus, the actual operation of a parallel computer system cannot be determined logically by the inputs to the system. The indeterminacy of the arbiters used in open computer systems results in their making decisions that cannot be proved from knowledge of structure of the computing system and its input.

**DECISIONS JUSTIFIED BY AGREEMENTS**

The electronic-banking system is a good example of an open system. You're probably familiar with it through the use of automated teller machines that enable you to withdraw cash thousands of miles from where you opened an account. Teller machines are continually being added to the system.

Decisions about which transactions to honor are justified on the basis of an agreement between the bank and its depositors. Often an agreement will provide that the bank does not have to honor a withdrawal if there are insufficient funds present in the

account when the withdrawal is requested. The withdrawal would be refused even though it might be covered by subsequent deposits.

The decisions of which withdrawals not to honor cannot be deduced from complete information about the structure of the bank's computers and the input from the teller machines. Thus, the decision whether or not to honor a withdrawal is not subject to logical proof. For example, suppose Account 1 has a balance of \$1000, Account 2 has a balance of \$2000, and they share a common reserve account with a credit limit of \$3000. If two electronic withdrawals of \$4000 each are attempted at about the same time from both Account 1 and Account 2, then one of the attempts will be refused and the other one will be honored, though it is impossible to deduce which one will be honored and which one refused.

The above example shows how a decision of an open system can be justified even though it does not follow from any proof. Instead, the decision is justified by an agreement to act in certain ways. We see a divergence between the theories used in the construction of open systems and their operation. Theory informs practice; e.g., the design of the banking mechanism is based on a financial theory. However, the financial theory does not determine the actual operations of the bank accounting system. The operation of the bank accounts is determined by the order in which asynchronous events occur inside the system. Each performance of a complicated open system is unique.

This illustrates the divergence between classic recursive-function theory and theories needed to model open systems. (For a further discussion of the mathematical semantics needed to model the behavior of open systems, see references 1 and 3.)

**EXPLORATION VS. SEARCH**

Searching in problem spaces is the traditional AI framework. Problem spaces and problems have been de-

finied as follows (see reference 16):

*Problem Space:* A problem space consists of a set of symbolic structures (the *states* of the space) and a set of *operators* over the space. Each operator takes a state as input and produces a state as output, although there may be other inputs and outputs as well. The operators may be partial, i.e., not defined for all states. Sequences of operators define *paths* that thread their way through sequences of states.

*Problem:* A problem in a problem space consists of a set of *initial* states, a set of *goal* states, and a set of *path constraints*. The problem is to find a path through the space that starts at any initial state, passes only along paths that satisfy the path constraints, and ends at any goal state.

A good example of a problem space is that of the game of chess:

1. *Initial state:* chess pieces in starting position
2. *Operations:* legal moves
3. *Goal states:* checkmate, stalemate, etc.

I claim that searching through problem-solving spaces provides a narrow foundation for the analysis and synthesis of intelligent systems. The perspective must be broadened to include *exploration* that goes beyond search. An excellent perspective on some of the differences between search and exploration is provided by the means used to explore and develop the North American continent.

1. *Initial state:* There was no well-defined initial global state of the
- (continued)





# New Qantex 7065. A fast printer at a slow price.

No matter how heavy the traffic, our new Qantex 7065 multimode printer will keep your documents flowing smoothly. At a very affordable price.

Use it for data processing, and the 7065 zips along at 300 cps bidirectionally. Both user-defined formats and six-part forms capability are standard.

Switch to word processing and the 7065 delivers near letter quality at 125 cps. Plus features such as proportional spacing, justification, auto-underline and bold.

And as a 65 cps letter quality

printer, it's fast enough and quiet enough to leave the competition in the dust. You get high density, double pass printing in your choice of some 20 fonts.

The 7065 is also a dot addressable graphics printer with resolution to 144 x 144 dots per inch and a full complement of line drawing graphics.

Besides being very fast, the 7065 is very compatible — with IBM, Apple, Lotus 1-2-3 and just about any other personal computer or software on the market. It offers built-in bar code capability. And its 500-million-plus char-

acter print head and industrial quality construction are designed for long, hard use.

To find out how quickly the Qantex 7065 could bring your information processing up to speed, contact Qantex for details or a demo. Qantex, 60 Plant Avenue, Hauppauge, NY 11788. Call toll-free 800-645-5292; in New York State 516-582-6060.

 **north atlantic**  
**Qantex**

North American continent in the middle 1600s. Leif Ericson and Christopher Columbus had led some early probes, but the information was fragmentary, dispersed, and self-contradictory.

2. *Operations*: The set of operations used to explore the continent was not defined in advance. Instead, it was improvised dynamically and interactively in the course of initial probes. Furthermore, the explorers operated *in parallel* so that there is no path of states of the continent that adequately explains how it was explored. That is, the continent was not explored by finding a single path through a space of states. Exploration of the North American continent can be better modeled as a partial order of causally linked historical events than as a problem space.

3. *Goal states*: There was no set of immutable global goal states for the continent that the explorers set out to achieve. Rather, the explorers' goals evolved with the exploration methods as the exploration proceeded.

Searching problem spaces is limited mainly in its applicability to artificial domains like chess and mathematical theorem proving. It is not very adaptable to the hurly-burly of solving problems involving interaction with the physical world. Problem spaces do not provide sufficient flexibility to represent the problem-solving processes of communities because of the attempt to represent the problem solving of individual actors as a single global state. This limitation of problem spaces is closely related to the inadequacies of the Turing machine as a model of asynchronous distributed systems. Problem solving in open systems is more analogous to the exploration of North America than the playing of games like chess.

**PLANNER**

Planner was one of the first AI programming languages to support goal-oriented problem solving without an externally specified problem space. It was based on the following principles (see reference 6):

- *Accessibility*: Planner aims for a maximum of flexibility so that whatever knowledge is available can be incorporated into the problem-solving process even if it is fragmentary and heuristic.

- *Pattern-directed invocation*: Procedures in Planner can be invoked by patterns of what they are supposed to accomplish. Suppose that we have a stopped sink. One way we could try to solve the problem would be to know the name of a plumber whom we could call. An alternative that is more analogous to pattern-directed invocation is to advertise the fact that we have a stopped sink and the qualifications needed to fix it. In Planner this is accomplished by making the advertisement (i.e., the pattern that represents what is desired) into a goal.

- *Procedural interpretation of logical statements*: One basic idea behind Planner

is to exploit the duality that we find between certain imperative and declarative sentences. Consider the statement (implies A B). The statement is a perfectly good declarative. In addition, it can also have certain imperative uses for Planner. It can say that we might set up a procedure that will note whether A is ever asserted and if so to consider the wisdom of asserting B in turn. Furthermore, Planner permits us to set up a procedure that will watch to see if it is ever our goal to try to deduce B and if so whether A should be made a subgoal. Exactly the same observation can be made about the contrapositive of the statement (implies A B). Statements with universal quantifiers, conjunctions, disjunctions, etc., can also have both declarative and imperative uses. Planner theorems are used as imperatives when executed and as

(continued)

**Now IBM AT Compatible**

# THE BRIEFCASE DATA BASE.

Your business needs more data base versatility than you get from hard disk systems. versatility to help your people work more productively, wherever they are, or go. Your business needs The Bernoulli Box,™ a storage system that lets you build and backup individualized data bases—for payroll, accounting, marketing—on rugged, interchangeable 5- and 10-megabyte cartridges.

It works more reliably, quickly, and flexibly than hard disk alternatives—without head crashes. And it works on the IBM PC, XT, AT, compatibles, the TI Pro and Apple's Macintosh.

**For the dealer nearest you, call 1-800-556-1234 ext. 215. In California call 1-800-441-2345 ext. 215.**

**OMECA**  
IOMEGA Corporation  
1821 West 4000 South  
Roy, Utah 84067

# THE BERNOLLI BOX™



Need RGB color and  
TTL monochrome  
support from a  
single board?

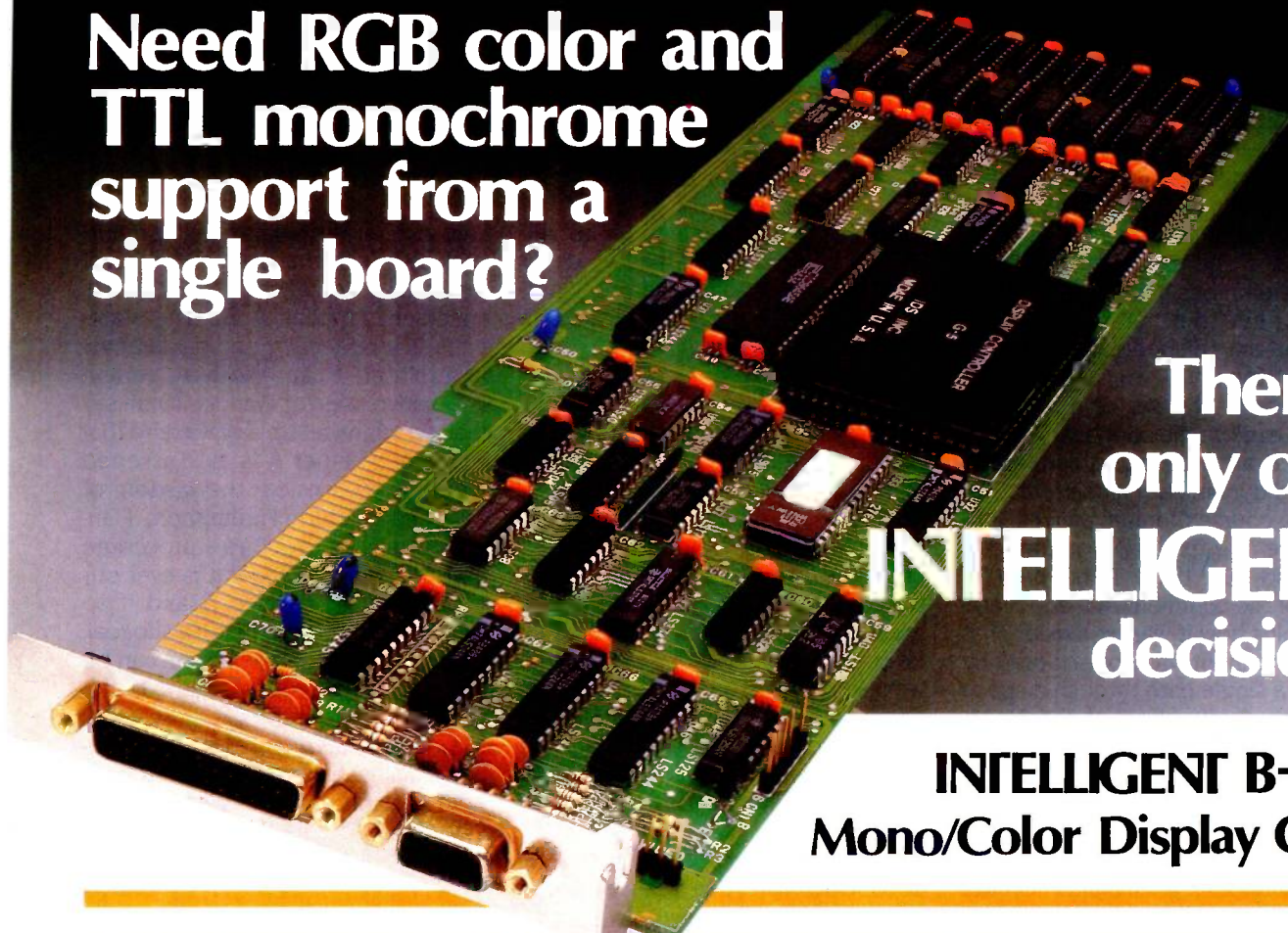

There's  
only one  
**INTELLIGENT**  
decision!

**INTELLIGENT B-450  
Mono/Color Display Card**



Color Graphics Mode: 640 dots x 200 lines

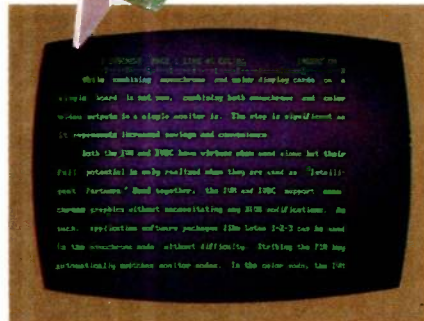

TTL Monochrome Mode: 640 dots x 350 lines

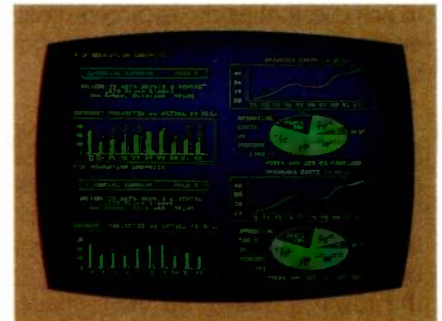

Interlace Mode: 640 dots x 400 lines

**L**ook no further, the INTELLIGENT B-450 has it all. Designed to work with the IBM PC, PC XT, and PC AT, the INTELLIGENT B-450 is also suitable for IBM PC look-alikes. In addition to a parallel printer port, the B-450 has fourteen different screen modes which cover everything from medium-resolution monochrome text to high-resolution color graphics with interlace.

Everyone from the ordinary user to the CAD/CAM specialist will find the B-450 is just right.

Sound good? With a suggested retail price of only \$294, it's nothing less than great!

IBM and IBM PC are registered trademarks of International Business Machines Corporation.

**INTELLIGENT  
DATA SYSTEM**

**Intelligent Data System, Inc.**

14932 Gwenchris Ct., Paramount, CA 90723

Toll Free Tel: (800)325-2455 Calif. Tel: (213)633-5504 Telex: 509098



declaratives when used as data.

Planner represented an advance over the "uniform proof procedures" of resolution theorem-proving systems then current. The design for Planner was implemented by Sussman, Winograd, and Charniak (see references 5, 23). Winograd used it to implement his interactive natural-language program, SHRDLU, for a world with simulated toy blocks (see reference 27).

In order to understand how procedural interpretation works, consider this logical statement:

(For All  $x$  ((man  $x$ ) implies (mortal  $x$ )))

The implication has two parts: the antecedent (man  $x$ ) and the consequent (mortal  $x$ ). It says: For every  $x$ , if  $x$  is a man, then  $x$  is mortal. Logical rules of inference permit certain deductions from the above statement. For instance, that Socrates is mortal can be derived from the premise that Socrates is a man as follows:

(Man Socrates)

-----  
(Mortal Socrates)

I proposed that logical implications like "all men are mortal" could be interpreted as procedures in a programming language. One interpretation, the *belief-invoked* interpretation (called the "antecedent interpretation" in Planner), provides that when the belief that  $x$  is a man is held, then the belief that  $x$  is mortal can be logically derived. We can express this as follows:

(when (belief (man  $x$ )) do  
    (believe (mortal  $x$ )))

Another interpretation, the *goal-invoked* interpretation (called the "consequent interpretation" in Planner), provides that from the goal that  $x$  is mortal, the subgoal that  $x$  is a man can be logically derived:

(when (goal (mortal  $x$ )) do  
    (show (man  $x$ )))

The ideas in Planner have been generalized and perfected in subsequent artificial-intelligence programming languages. However, by them-

selves they do not address the needs of open systems.

### LOGIC PROGRAMMING

Logic programming has been proposed by some as the programming paradigm for the future (see reference 12). Let's focus on limitations that are inherent in the enterprise of attempting to use logic as a programming language for dealing reliably with empirical knowledge and interacting with the physical world. The remarks in this section continue a debate that begins with the genesis of AI. I recommend that interested readers consult the appendix to Marvin Minsky's frames paper (see reference 15) and the subsequent analysis of David Israel (see reference 8).

Logic programming must be based on logic. But what is logic? First-order logic, with its well-defined semantics and syntax, is the basis claimed by

most of those who call themselves logic programmers. In part, the confidence of logic programmers is based on the fact that first-order logic augmented with set theory has proved to be a good foundation for mathematical semantics.

Omega-order logic is an extension to first-order logic that allows quantification over predicates and functions. It has advantages over first-order logic in that it includes the full lambda calculus as a sublanguage and has arbitrary powers of abstraction. When certain technical problems having to do with Russell's Paradox have been dealt with, omega-order logic may be the preferred logical language (see reference 19). Therefore, we should consider it to be in the mainstream of logic programming. Experts have argued that the merits of other logics can be found in first-

(continued)

**Now IBM AT Compatible**

# THE SAVING GRACE DATA BASE.

Businesses today need more than just more data capacity from mass storage devices. They need more data dynamics. And that means backup as well as primary storage. The Bernoulli Box,™ with its removable storage system, delivers both. Not only can you create individual data bases on handy 10-megabyte cartridges (5 megabytes on the single-drive Macintosh™ box), you can backup files—in minutes, not hours. The compact cartridges are easily stored. And with the lowest available cost-per-megabyte, you not only save your data, but money and time as well.

The Bernoulli Box. Available for the IBM PC, XT, AT, most compatibles, the TI Pro and Apple's Macintosh.

**For the dealer nearest you, call 1-800-556-1234 ext. 215. In California call 1-800-441-2345 ext. 215.**

**OMEGA**  
IOMEGA CORPORATION  
1821 West 4000 South  
Roy, Utah 84067

# THE BERNOLLI BOX™



order logic (see references 14 and 26), so the analysis in this article is confined to first-order logic without loss of generality.

**THE INCONSISTENCY PROBLEM**

I make the following claim, which I call the Conjecture of Inconsistency: The axiomatizations of the human knowledge of all physical systems are uniformly inconsistent in practice.

I've used the term *conjecture* because the above claim is in principle impossible to prove rigorously, easy to disprove by counterexample, and has a preponderance of evidence in its favor. The reasons for the inconsistency have to do with the dispersed asynchronous nature of human knowledge, including the following factors:

- *Environmental context:* The physical system being axiomatized is related to various other physical systems. For ex-

ample, a diseased kidney is often related to a diseased heart. Knowledge of the kidney cannot be separated from knowledge of the heart.

- *Spatiotemporal context:* A physical system is situated in space and time. Knowledge of the physical system comprises knowledge of its history and mode of production.

- *Terminological context:* The predicates used in the axiomatization of the properties of a physical object are always somewhat problematic in practice. For example, specifying in practice what it means for a physical table to be flat raised many problematic issues.

- *Evidential context:* It is impossible to separate what we know about a physical object from how we came to know it. Axiomatization of the methods by which the axiomatized knowledge came to be known further enlarges the axiomatization.

The DEC System-20 is a good case in point. In the first place, observe that the DEC System-20 is an extremely simple system in comparison with, say, the human kidney. Furthermore, the DEC System-20 is an artificial human construct that was designed to be consistent with some simple requirements. Nevertheless, despite the best efforts of software engineers, the formal description (axiomatization of documentation and code) of the DEC System-20 remains inconsistent. There are inconsistencies in the documentation as well as inconsistencies between the documentation and the code. Although inconsistencies are continually being removed from the system, the experience is that more inconsistencies are always found immediately.

Suppose that we were given unlimited funding to undertake the job

(continued)

# TWO USERS on a single board

available in:

## 8BIT

- 8 MHz Z80H-CPU speed
- 256K per user
- Can be used as a TPA or as a built-in RAM disk
- Draws only 700 milliamps

## 16BIT

- 8 MHz 8088-2 CPU
- 128K-512K per user
- DMA data transfer to system master

With these dual slave boards, each a powerful single board computer, you can double the users in your S-100 computer without sacrificing system speed. Mix and match them with virtually any other slave or system masters.

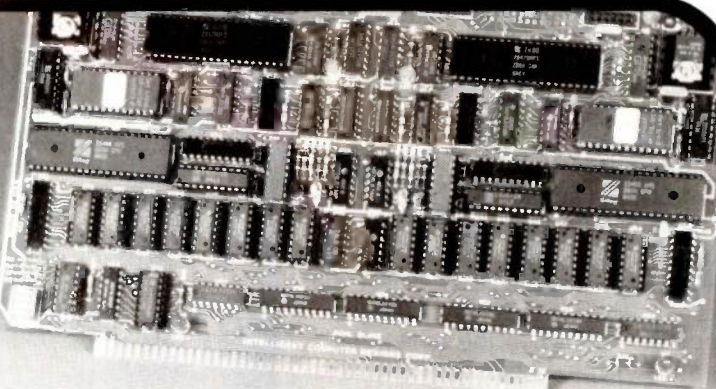

Place your orders now to ensure fast delivery.

**COMING SHORTLY!**  
A new Z80H, 8 MHz master board with on-board HDC/FDC/Tape, supporting following interfaces: ST506, SA1000, ST412HP, ESDI, and the new RLL encoding methods.

IBM-PC is a registered trademark of IBM Corp.  
MS-DOS is a trademark of Microsoft Corp.  
Turbo-Dos is a trademark of Software 2000, Inc.  
CP/M is a trademark of Digital Research Corp.



**Intelligent Computer Designs Corp.**  
9252 Garden Grove Blvd.  
Garden Grove, CA 92644  
Tel: 714-638-3622  
TLX: 312659-INTELL Comp-UD





# We've Put a Local Area Network on a Disk

Corporate Information Sharing. It's been described as the key to increasing a company's productivity. It's also why large networks of PC's are becoming more and more common in the workplace...in spite of the fact that they're costly, difficult to install, and incompatible with much existing software.

Finally, there's a solution to this corporate dilemma. Its name is LANLink™.

**A Software-Driven LAN That Uses Standard, RS-232 Ports.** A major breakthrough in local area networks, LANLink™ uses your computers' existing serial ports and runs under PC-DOS.

Because all of the intelligence the network requires is on the server and satellite diskettes, expensive network interface boards aren't required.

**A Powerful Network That's Cost-Conscious.** If you've been pricing board-driven LAN's, you already know that they can cost over \$1,000 per workstation.

LANLink™ is different.

Boasting a data transfer rate in excess of 100,000 BPS, LANLink™ is compatible with a wide range of programs. And because special boards aren't required, installation costs are one-third that of a traditional network.

**A Network Designed the Way Business Works.** With LANLink™ you're able to customize your network along departmental lines using a data-sharing hierarchy and password-protected access.

**Get Started With LANLink™ TODAY.** Call The Software Link TODAY for complete details and the authorized dealer nearest you. The LANLink™ Starter Kit, priced at \$495, comes complete with network software for both a server and a satellite computer. For a limited time, 50 feet of RS-232 cable will be included free of charge.

LANLink™ is immediately available and comes with a money-back guarantee. VISA, MC, AMEX accepted.

# LANLink™



**THE SOFTWARE LINK, INC.**

Developers of MultiLink™ and MultiLink Advanced™

8601 Dunwoody Place, Suite 336, Atlanta, GA 30338 Telex 4996147 SWLINK

CALL: 404/998-0700

Dealer Inquiries Invited

MultiLink, MultiLink Advanced & LANLink are trademarks of The Software Link, Inc. PC-DOS is a trademark of IBM Corp.

Inquiry 354



# Sweet-P

## Sweet-P Model (SP600)

**A six-pen graphics plotter that's more compatible . . . uses more software.**

Last year 430 million business slides were made at a cost of \$3.2 billion. Most of these slides were manually generated.\* These slides could have been made on Sweet-P® Personal Plotters™. Faster and better. With a savings of millions of \$!

The Sweet-P SP600 is a high quality American made precision machine. It's fast. It plots 14 inches per second. It's beautiful for office and technical work.

Over 100 graphics software packages drive the Sweet-P™ world famous packages like Lotus 1-2-3™, Framework™ and Super-Calc™ technical software like AutoCAD™, PCAD Robographics™ and dedicated business graphics software such as Micro-soft Chart, ChartStar™, Energraphics™, Chart-master™ and pfs Graph™.

Pens are capped automatically when not in use, so that pens last longer and start quicker.

only \$1,095

The Sweet-P easily connects to almost any computer. It has RS-232 serial and Centronics™ parallel connectors. And it supports two standard graphics languages—Sweet-P Graphics Language (SPGL™) and Hewlett-Packard Graphics Language (HPGL™).

The Sweet-P plots on almost any media. Make brilliant overhead transparencies. Plot on film, and on plain and coated papers.

Save on wiring costs too. The Sweet-P will "eavesdrop" on the RS-232 cables that connect your terminals now. (This makes it easy for Sweet-P to join local and long distance networks.)

What about support? Sweet-P customers get fast professional help with software, hardware and interface questions. And warranty and service support is quick.

Sweet-P Model 600 also comes with 18 ANSI ASCII internal Character sets.

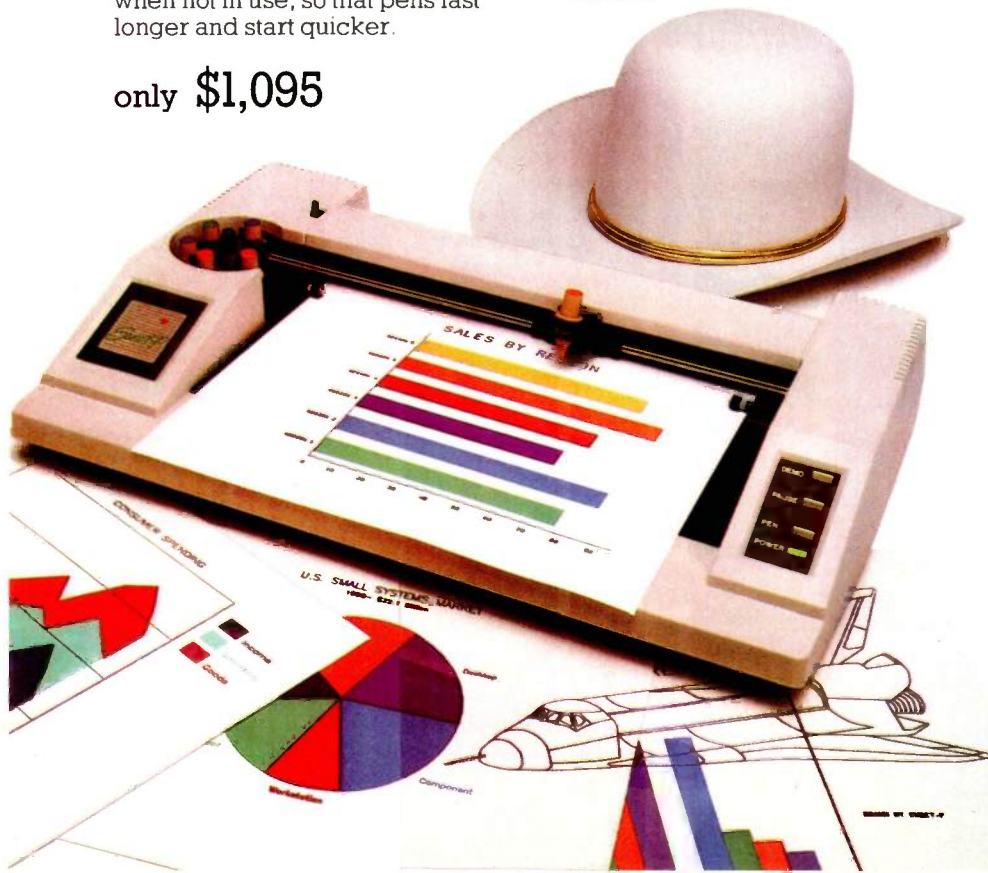

### U.S. DISTRIBUTORS

#### Arizona

First Source Distributing  
(602) 263-1950

#### California

Zenith Data Systems • (415) 621-8545

#### Colorado

Ares Distributing • (303) 752-2972

#### Florida

Cain Bultman • (904) 356-4812

#### Illinois

PC Distributing • (312) 356-4812  
Zenith Data Systems • (312) 562-7300

#### Kansas

Inland Computer • (913) 492-9100

#### Maryland

Federal Data • (301) 986-0800

#### Missouri

Computime, Inc. • (314) 991-2991

#### North Carolina

Allison-Erwin • (704) 334-8621

#### New Jersey

Data Research • (201) 569-2620  
Buhl Industries • (201) 423-2800

#### Pennsylvania

Peirce Phelps, Inc. • (215) 879-7068  
Pryor Corp • (800) 245-0209  
Chessell Robocom • (215) 968-4422

#### Tennessee

Multi Computer Products  
(615) 528-7777

#### Texas

AMCAD, Inc. • (214) 323-0700  
National Marketing Inc.  
(214) 386-8151

#### Washington

Comquest Systems • (206) 641-7650

#### Canada

Altel Data • (403) 259-7814  
Interworld Electronics Inc.  
(604) 984-4171  
The Pringle Group  
(416) 449-5640

Enter Computer Inc.  
6867 Nancy Ridge Dr.  
San Diego, CA 92121

619-450-0601 • 800-227-4371 CA  
800-227-4375 • TELEX-181740

Come see us at these Trade Shows  
March 21-24 Comdex/Anaheim  
CA • Booth #1182  
April 14-18 NCGA 85'/Dallas, TX  
Booth #506

Trademarks: Sweet-P, Six Shooter, Personal Plotter, SPGL, Enter Computer, Inc., HPGL, Hewlett-Packard; Lotus, Lotus Development Corp.; Framework, Ashton-Tate; Super-Calc, Sorcim, Inc.; AutoCAD, Autodesk; PCAD Robographics, Chessell-Robocom, Inc.; Chart Star, Micro-Pro Int'l Corp., Energraphics, Enertronics Research, Inc.; pfs Graph, Software publishing Corp.; Chart-Master, Decision Resources; Centronics, Centronics Corp.

Source notes: \*Yankee Group, The Technical Office, Vol.III 1983

\*\*Wharton School Study, September 1981

Inquiry 143 for Dealers

Inquiry 144 for End Users

of making the description of the DEC System-20 consistent. We would have to control the process by which the system grows and evolves. In particular, we would have to handle all changes to the documentation and code in face of the following external requirements:

- Bugs in both the code and documentation must be fixed
- New functions must be incorporated to meet the customers' changing needs
- The system must accept changing interfaces to other systems such as peripherals and networks

There is no way to prove that the process by which the DEC System-20 evolves will result in new releases with consistent formal descriptions. An axiomatization of the code and documentation of even a system as simple

as the DEC System-20 is, in practice, inconsistent despite enormous efforts made to achieve consistency.

A second claim I make is that the axiomatizations of the human knowledge about any physical systems will forever be inconsistent. I call it the Conjecture of Perpetual Inconsistency: Removing some inconsistencies from an axiomatization of the human knowledge about a physical system leaves an axiomatization which is nevertheless inconsistent.

**MESSAGE-PASSING SEMANTICS**

Consideration of the previous claim suggests that we need to examine how logic treats inconsistency. Inconsistencies have some important implications of the utility of logic programming as a foundation for intelligent systems. The logical view of inconsistent theories is clear: They are meaningless because they corre-

spond to no possible world. The logical account of meaning is too stringent for nontrivial empirical systems because inconsistent beliefs and descriptions are not meaningless. Inconsistency is inherent in the enterprise of expressing the human knowledge of physical systems. A theory of meaning that maintains that inconsistent descriptions are meaningless is not directly applicable to problems of empirical knowledge.

In model theory, the meaning of a sentence is determined by the models that make it true (see reference 24). For example, the conjunction of two sentences is true exactly when both of its conjuncts are true. Truth-theoretic semantics assumes that it is possible to give an account of truth in itself, free of interactional issues, and that the theory of meaning can be based on such a theory of truth.

(continued)

# Cheap Shot.

**Get instant slides and prints directly from your personal computer. Introducing Screenshooter.™ Only \$175.**



Now there's a simple, low-cost way to make instant prints and slides from any color or

monochrome computer monitor. Do it yourself. On-the-spot. Right at your own desk.

Screenshooter includes the Polaroid OneStep 600 instant camera, CRT hood, CRT hood adapter, diopter lens, and 35mm SLR camera bracket. Plus a 90-day money-back satisfaction guarantee!

Add the Polaroid 35mm Instant Slide System and use your 35mm camera to make instant slides for last-minute presentations. The system includes an AutoProcessor, slide mounter, and custom slide mounts. Just \$99.

**Free Film Offer.\***

Order by June 30, 1985 and get two free packs of Polaroid 600 High Speed film with your Screenshooter and two free 12-exposure rolls of Polachrome Instant Slide film with your 35mm Instant Slide System.

Why wait?



\*Offer void where prohibited. U.S. residents only. "Polaroid" ® "Screenshooter"™

**Shoot your computer for \$175!**

Send check, money order, credit card number, or corporate purchase order, plus the completed coupon to: NPC Screenshooter Promotion, P.O. Box 245, Newton Upper Falls, MA 02164. Or call: 800-225-1000.

Please rush me:

Screenshooter(s) @ \$175 \_\_\_\_\_

Polaroid 35mm Instant Slide System(s) @ \$99 \_\_\_\_\_

Shipping and handling (@ \$1.75 per item) \_\_\_\_\_

Add sales tax where applicable \_\_\_\_\_

Total purchase price \_\_\_\_\_

I would like to pay by:  Corporate Purchase Order  MasterCard  VISA  Check/Money Order

CORPORATE PURCHASE ORDER NUMBER \_\_\_\_\_

CREDIT CARD NUMBER \_\_\_\_\_ EXPIRATION DATE \_\_\_\_\_

SIGNATURE \_\_\_\_\_

NAME \_\_\_\_\_

ADDRESS \_\_\_\_\_

CITY \_\_\_\_\_ STATE \_\_\_\_\_ ZIP \_\_\_\_\_

TELEPHONE \_\_\_\_\_

**Screenshooter**

A product of Newton Plastics Corp. B 4/85



Message-passing semantics takes a different perspective on the meaning of a sentence: It takes the meaning of a message to be the effect it has on the subsequent behavior of the system. In other words, the meaning of a message is determined by how it affects the recipients. Each partial meaning of a message is constructed

by a recipient in terms of how it is processed (see reference 12). At a deep level, understanding always involves categorization, which is a function of interactional (rather than inherent) properties using the perspective of individual viewpoints (see reference 13). Meaning is thus fundamentally interactional. The meaning of a message

is open-ended and unfolds indefinitely far into the future as other recipients process the message. According to message-passing semantics, meaning is communication-based, not logic-based.

### NEED FOR DUE-PROCESS REASONING

In the presence of conflicting information and contradictory beliefs, logical proof is inadequate as a reasoning mechanism. Instead we need *due-process reasoning* that investigates different sides of beliefs, goals, and hypotheses that arise.

Consider the following hypothesis to illustrate due-process reasoning: "Nixon was guilty of destruction of evidence in the Watergate case by erasing a portion of a tape recording." One possible approach in logic programming is to gather evidence in favor of the hypothesis and attempt to fashion the evidence into a logic proof (perhaps augmented with "certainty factors" or "default assumptions"). The other approach is to use "negation as failure" to conclude that the hypothesis is false because it cannot be proved from the available knowledge. Both of the approaches are inadequate in this case. No matter how much evidence is produced and analyzed, logical proof (either for or against Nixon's guilt) is unbalanced because it presents only one side of the case in the form of a proof. Using "negation as failure" to draw conclusions from the inability to construct such a proof is equally limited. A balanced approach requires debate between differing positions and weighing presented evidence. Debates are not structured in the same way as logical proofs.

Due-process reasoning is the process of collecting and analyzing the evidence and arguments presented by all interested parties. *Advocates* collect evidence and organize arguments in favor of the hypothesis. In parallel, *skeptics* collect evidence and organize arguments against the hypothesis. Then a debate is conducted on grounds for deciding the case in terms of  *motive* and *ability*. The ques-

**Z-Engine delivers CP/M® for your Apple®**

Z-Engine delivers a trainload of additional programs to your Apple II, II+, IIe or Apple compatible computer. Many of the most powerful and sophisticated programs available today are CP/M based; **Z-Engine opens the door to them all.** You might expect that something that gives so much would cost so much. Not so. Z-Engine is, undoubtedly, one of the greatest values in the microcomputer industry. Z-Engine is first class service at economy fare. Once the Z-Engine has been delivered we don't shut off the steam - we support our products - and guarantee them. **If you knew what we know about the Z-Engine you'd be our next customer.** The Z-Engine delivers.

**Advanced Logic Systems**  
1195 East Arques Ave.  
Sunnyvale, CA 94086  
(408) 730-0307.

**als**

CP/M is a registered trademark of Digital Research Inc. Apple is a registered trademark of Apple Computer, Inc.



tion of motive is whether Nixon thought that he would benefit by erasing the tape. The question of ability is whether he could have erased the tape. Both advocates and skeptics *recursively* make use of due-process reasoning while investigating, organizing, and presenting their cases. The advocates and skeptics operate interdependently in collecting evidence (through discovery processes and disclosure requirements) as well as interacting by debating each others' cases in a decision-making process that is fundamentally different from logical proof.

### PROLOG

Advocates of logic programming initially developed a programming language called Prolog that was based on the goal-invoked procedural interpretation of implication discussed earlier in the section on Planner (see reference 11). The example discussed earlier to the effect that "In order to show that *x* is mortal, establish a subgoal to show that *x* is a man" is written in Prolog as:

```
mortal (x) :- man (x)
```

The original Prolog was a much simpler language than Planner, which was a considerable advantage in terms of pedagogy and ease of implementation. But now Prolog, like the Planner-like languages before it, has fissioned into incompatible dialects based on the procedural interpretation of logic, pattern-directed invocation, message-passing theory, and description systems (see references 4, 9, and 12).

In addition to the general limitations of logic programming discussed earlier, Prolog has some idiosyncratic weaknesses all its own. The closed-world assumption is the hypothesis that the locally available knowledge is complete; i.e., if a proposition does not follow from the local knowledge base, then it is assumed to be false (see reference 18). Planner could make use of the closed-world assumption using its ability to conditionalize a plan (theorem) on the exhaustive

(continued)

# How Do I Choose the Right Personal Computer Monitor?





Engineering  
Excellence

CROSSTALK™  
XVI



THE STATE OF THE ART IN  
DATA COMMUNICATIONS  
SOFTWARE

DESIGNED BY

**MICROSTUF**®

CROSSTALK IS A TRADEMARK OF  
MICROSTUF, INC., ATLANTA, GEORGIA

CROSSTALK IS AVAILABLE FOR  
MOST SMALL BUSINESS  
COMPUTERS

DATE

2/16/84



failure to establish a goal. In fact, Winograd made strong use of the capability in SHRDLU. Influenced by Planner, Prolog went much further and adopted a very strong form of the closed-world assumption as a basic postulate of the programming language in incorporating *negation as failure*. (Relational database systems make use of a similar strong hypothesis: If an entry is not found in a relational table, then the relationship is false.) The strong use of the closed-world assumption in Prolog is incompatible with the need in open systems to allow for the open-ended incremental introduction of new beliefs and objects.

**INFORMATION-PROCESSING PRINCIPLES FOR THE FUTURE**

The term *reflection* has been much discussed in the current AI literature (see references 2, 4, 7, 22, and 26). It is universally conjectured that reflective problem capabilities will be important to improving machine problem-solving capabilities. However, a danger is developing that the important problems will be neglected unless reflective problem solving is taken to encompass the following *minimum* capabilities:

- *History of its own behavior*: What did you do then?
- *Representation of its own information-processing procedures*: How do you make decisions?
- *Knowledge of the relationship between its previous behavior and current procedures*: What would you do differently and why?
- *Representation of its procedures for interacting with the external world*: How do you control things?

The current state of the art in implementing reflective systems is extremely primitive. Many of the issues and questions itemized above have not yet been properly addressed.

Besides reflective problem solving, other principles should be adopted in constructing reliable systems that meet the needs of open systems.

(continued)

# Will It Work with My PC?

Before you can experience the full capabilities a high performance monitor offers, it has to work with your personal computer. That's why Princeton Graphic Systems makes high resolution monitors compatible with most popular brands of personal computers. IBM, Compaq, Corona, Apple and more. But we go one step further. By paying close attention to ergonomic detail, we make Princeton Graphic Systems monitors compatible with you, the computer system user...

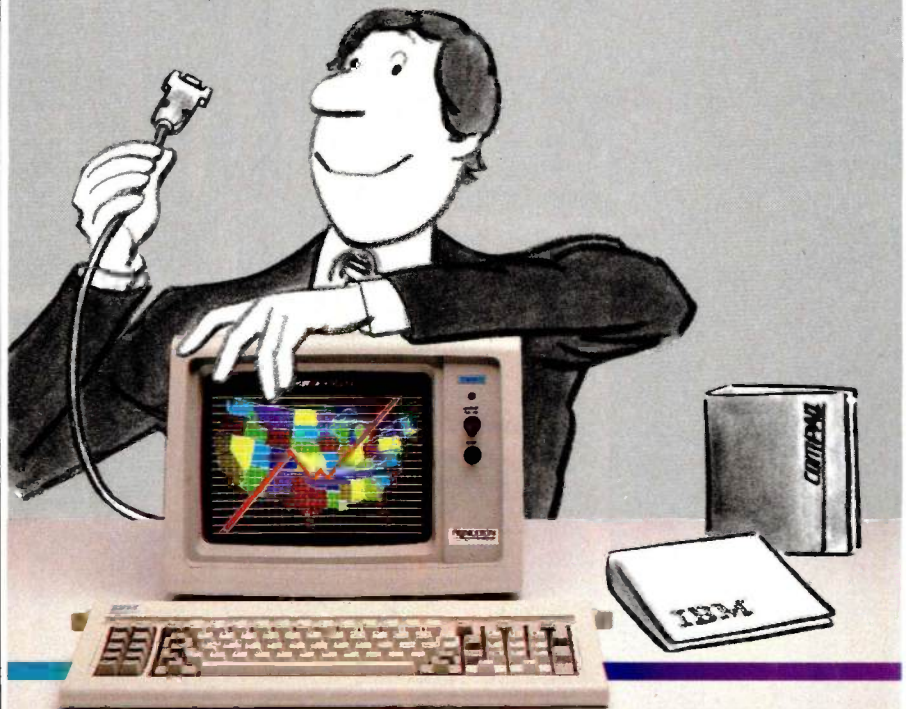



# THE SAKATA CONNECTION

## Your personal computer deserves the unequalled monitor quality of Sakata

Your computer deserves the most monitor quality value possible...and so do you. SAKATA CRT DISPLAY MONITORS give you more monitor quality than the most expensive monitors available. Each SAKATA MONITOR provides unequalled color reproduction; sharpest and most vivid graphics; text that you read more easily than you ever expected; and technical characteristics and capabilities that will amaze you.

Protect your personal computer's

performance by utilizing SAKATA CRT MONITORS which provide the utmost in monitor value. Choose from an entire line of Composite Color; RGB High Resolution Color; RGB Super High Resolution Color and two monochromes (green and amber) that have more quality than other monochrome monitors. **"We promise performance".**

SAKATA CRT MONITORS are available wherever personal computers are sold or write for technical and illustrated literature and prices.

SAKATA U.S.A. CORPORATION  
651 Bonnie Lane, Elk Grove Village, IL 60007  
(312) 593-3211 800-323-6647 (outside Illinois)

# Sakata

"Serving industry worldwide since 1896"

SC-100  
COLOR COMPOSITE



SC-200  
RGB HIGH  
RESOLUTION COL



SC-300  
RGB SUPER HIGH  
RESOLUTION COLOR



SG-1000  
MONOCHROME GREEN



SA-1000  
MONOCHROME AMBER





- *Serendipity*: It is not critical whether the system learns of a result before it can be used in a problem-solving task or after work has commenced on the task.
- *Pluralism*: There is no central arbiter of truth in the system.
- *Accessibility*: All knowledge of the system (including its own procedures) should be able to be applied to any problem.
- *Parallelism*: The system should be able to mobilize its full resources in parallel instantiations for different aspects of large-scale problems.
- *Due-process reasoning*: The system collects and debates alternatives to decide among beliefs and goals.
- *Reflection in practice*: Knowledge (including self-knowledge) should inform practice, and practice should modify hypotheses, beliefs, and goals.
- *Reasonableness*: The system should perform efficiently in the face of conflicting information and inconsistent beliefs.

### CONCLUSIONS

In practice, the human knowledge of a physical system cannot be consistently axiomatized. Every physical system is open in the sense that it is embedded in a larger physical environment with which it interacts asynchronously. In general, open systems are not totally in control of their fate. In contrast, closed systems (like Peano arithmetic and point-set topology) are exactly characterized by rules and laws.

Proponents of logic programming have maintained that it is a suitable basis for all programming and is the programming paradigm for the future. Logic programming has some fundamental limitations that preclude its becoming a satisfactory programming methodology. It is inadequate for the needs of open systems because it is based on logical operations instead of communication primitives and logical reasoning instead of due-process reasoning. Decisions in open systems are justified by agreements to act in certain ways. Justification by agreement stands in contrast to justi-

(continued)

# Does It Give Me A Bright, Sharp Image?

Take a close-up look at the display. Bright, crisp characters and sharp, colorful graphics mean you're getting a high-quality image. The kind of image that comes with every Princeton Graphic Systems' monitor. Because Princeton Graphic Systems combines flicker-free technology, a fine dot pitch, and a nonglare screen to give you an image that *PC World's* World Class Survey rates number 1 . . .





*Only from Topaz...*

# Powermaker<sup>®</sup> Micro UPS

**Uninterruptible, computer-grade power  
—at half the cost**



It's in a class by itself.

For about half the cost of other Uninterruptible Power Systems, you can now get the same degree of protection with our Powermaker Micro UPS. This remarkable new system eliminates computer problems caused by blackouts, brownouts, voltage sags and power-line noise.

Providing up to 75 minutes of continuous computer-grade power, our Powermaker Micro UPS is compatible with microcomputers and PC's. It's fully automatic, maintenance-free, portable and compact. It fits neatly alongside or under your desk or workstation. And because you can't always tell when you've lost primary power, our little UPS even features an audible line-loss alarm.

But best of all is the price. The Powermaker Micro UPS is priced right and is ready for immediate shipment. Find out more about our Powermaker Micro UPS. Call us at (619) 279-0831, or contact your local Square D distributor.

**TOPAZ<sup>®</sup>**

*Excellence in Computer Power*

**SQUARE D COMPANY**



fication by logical proof; interaction with the physical world involves dealing with conflicting and contradictory information in a way that does not fall within the scope of decision making by logical proof. Prolog also suffers from the limitation of "negation as failure," restricting it to a closed-world assumption that is incompatible with the nature of open systems.

We need foundations for intelligent systems based on principles of commutativity, pluralism, accessibility, reflection in practice, and due-process reasoning. Logical reasoning is a useful module in the repertoire of an intelligent system, but it is not the whole show. ■

ACKNOWLEDGMENTS

Many of the ideas in this paper have been developed jointly with the members of the MIT Message Passing Semantics Group and the Tremont Research Institute. I would especially like to express my appreciation to Gul Agha, Gerald Barber, Peter de Jong, Elihu M. Gerson, and Susan Leigh Star for their aid and the foundational work on which this paper builds. Jonathan Amsterdam, Mike Brady, Mike Brooks, Toni Cohen, Peter de Jong, John Kam, Henry Lieberman, John Mallery, Fanya Montalvo, Karen Prendergast, Claudia Smith, and John Teeter provided valuable comments and criticisms that helped greatly to improve on earlier drafts. Over many years I have benefited from extensive interactions with Richard Weyhrauch, who has a profound understanding of the issues discussed here.

The content of this paper comes from talks I have given at Stanford University in June 1983, at panels for IFIP-83 in Paris, at the MIT Artificial Intelligence Laboratory in November 1983, at BBN, at MIT Sloan School, and at the AAAS in New York during June 1984. Comments, criticisms, and arguments developed in these seminars have been invaluable in developing this paper. I would like to express special appreciation to Bob Moore, Nils Nilsson, Steve Hardy, Richard Waldinger, and others for valuable feedback during and after the Stanford seminar; Bob Kowalski and Doug Ross at the IFIP-83 panel; Jan Komorowski at the MIT seminar; David Israel at the BBN seminar; Tom Malone and Gerald Barber at the Sloan School seminar; as well as Victor Lesser, Jerry Hobbs, and Lucy

(continued)

# How About Dependability?

You rely on your personal computer system to help get your work done. That's why it's important to choose a monitor built for reliability. Princeton Graphic Systems monitors are built under the highest quality control standards, backed by a full one-year warranty and supported by a nationwide service network.\* The result: monitors that perform when you need them, day in and day out . . . .

\*Bell & Howell, Xerox, MAI Sorbus Service and Princeton Graphic Systems.





# INCREDIBLE DATABASE VALUE

**A multifile database with a programming language—at a fantastic price!**



VersaForm's new XL database isn't just promises—it's here now! InfoWorld gave it a 3-Star rating . . . same as dBASE III\*. Yet XL offers—FOR ONLY \$99!—all the features you'd expect in a database costing 4 times as much!

Accounting applications are XL's strength. Invoicing, purchasing, and shipping almost create themselves as you design the forms. A/R and inventory examples are included in the package.

XL has over 50 built-in functions to control file access, printing, and user dialogues. Develop transaction-based applications faster than with any other database!

- Structured language accesses multiple files.
- Columns that scroll can be part of any record.
- Automatic calculations for totals, taxes, etc.
- Automatic entry checking prevents errors.
- Prints on your existing pre-printed forms.

### COMPARE THE BIG THREE

	VersaForm XL	dBASE III*	R:BASE 4000*
PRICE	\$99	\$95	\$495
STRUCTURED LANGUAGE	Y	N	Y
COLUMNS WITHIN DATA RECORDS	Y	N	N
ON-SCREEN CALC	BUILT-IN	MUST WRITE PROGRAM	MUST WRITE PROGRAM
FORMS OUTPUT	BUILT-IN	MUST WRITE PROGRAM	MUST WRITE PROGRAM
DATE ARITHMETIC	Y	Y	N
DATA TYPES	DYNAMIC	FIXED	FIXED
COLUMN TOTAL OPERATOR	Y	N	N
QUERY BY EXAMPLE	Y	N	EXTRA
MAX FILE SIZE	4 MB	OPEN	OPEN
MAX RECORD SIZE	4000	4000	1530

### Ironclad Money Back Guarantee

Try VersaForm XL for 30 days. If not fully satisfied, return it for your money back.

Single-File version \$69

Now just **\$99**

**Toll-Free: 1-800-538-8157 ext. 880**

In California, call:

**Toll-Free: 1-800-672-3470 ext. 880**

Applied Software Technology (408) 370-2662  
1350 Dell Avenue, Ste. #206-xx, Campbell, CA 95008

Yes! I want:

- \_\_\_\_\_ VersaForm XL for IBM PC, XT, AT, etc. (\$99)  
Needs 192K, 2 drives. Hard disk recommended.
- \_\_\_\_\_ Single-file VersaForm for IBM, etc. (\$69)  
Needs 128K, 2 drives or hard disk.
- \_\_\_\_\_ Single-file VersaForm for Apple II (\$69)  
Needs 64K, 2 drives.

Include \$4.50 for U.S. shipping. \$7.50 for C.O.D.  
California residents add 6.5% tax. Allow 2-3 wks.  
Check enclosed \_\_\_\_\_ MasterCard \_\_\_\_\_ VISA \_\_\_\_\_ C.O.D.

Acct. No. \_\_\_\_\_ Expires: \_\_\_\_\_

PLEASE PRINT CLEARLY

Name \_\_\_\_\_

Address \_\_\_\_\_

City \_\_\_\_\_ State \_\_\_\_\_ Zip \_\_\_\_\_

Phone \_\_\_\_\_ Sign here \_\_\_\_\_

\*dBase III is a registered trademark of Ashton-Tate.

R:BASE 4000 is a registered trademark of Microrim Inc.

## OPEN SYSTEMS

Suchman at the AAAS session. Allen Newell took the time to give me an overview of some of the aspects of his recent work on foundations in July 1984.

This paper describes research done at the MIT Artificial Intelligence Laboratory. Major support for the research reported in this paper was provided by the System Development Foundation and Wang Laboratories. Major support for other related work at the Artificial Intelligence Laboratory is provided, in part, by the Advanced Research Projects Agency of the Department of Defense under Office of Naval Research contract N0014-80-C-0505. I would like to thank Charles Smith and Patrick H. Winston for their support and encouragement.

### REFERENCES

1. Agha, Gul. "Semantic Considerations in the Actor Paradigm of Concurrent Computation." *Proceedings of the NSF/SERC Seminar on Concurrency*. New York: Springer-Verlag, 1984.
2. Batali, J. "Computational Introspection." *AI Memo 701*. Cambridge, MA: MIT Artificial Intelligence Laboratory, February 1983.
3. Clinger, W. D. "Foundations of Actor Semantics." *AI-TR-633*. Cambridge, MA: MIT Artificial Intelligence Laboratory, May 1981.
4. Doyle, J. "A Model for Deliberation, Action, and Introspection." *AI-TR-581*. Cambridge, MA: MIT Artificial Intelligence Laboratory, 1980.
5. Hewitt, C. "PLANNER: A Language for Proving Theorems in Robots." *Proceedings of IJCAI-69*. Washington, DC: IJCAI, May 1969.
6. Hewitt, C. "Description and Theoretical Analysis (Using Schemata) of PLANNER: A Language for Proving Theorems and Manipulating Models in a Robot." *AI-TR-258*. Cambridge, MA: MIT Artificial Intelligence Laboratory, April 1972.
7. Hewitt, C., and P. de Jong. "Analyzing the Roles of Descriptions and Actions in Open Systems." *Proceedings of the National Conference on Artificial Intelligence*, AAAI, August 1983.
8. Israel, D. "A Short Companion to the Naive Physics Manifesto." In *Formal Theories of the Common Sense World*, J. Hobbs, ed. Abelex, 1984.
9. Kahn, K. "How to Implement Prolog on a LISP Machine." In *Implementations of Prolog*, Campbell, J. A., ed. New York: John Wiley & Sons, 1984, pages 117-134.
10. Kornfeld, W. A., and C. Hewitt. "The Scientific Community Metaphor." *IEEE Transactions on Systems, Man, and Cybernetics*, SMC-11, 1, January 1981.
11. Kowalski, R. A. "Predicate Logic as Programming Language." *Proceedings of IFIP-74*. IFIP, 1974.
12. Kowalski, R. A. In *The SIGART Special Issue on Knowledge Representation*, R. Brachman and B. Smith, eds. SIGART, 1978.
13. Lakoff, G., and M. Johnson. *Metaphors We Live By*. Chicago: University of Chicago Press, 1980.
14. McCarthy, J. "First Order Theories of Individual Concepts and Propositions." Stanford, CA: Stanford University Press, July 1977.
15. Minsky, M. "A Framework for Representing Knowledge." In *The Psychology of Computer Vision*, Winston, P., ed. New York: McGraw-Hill, 1975.
16. Newell, Allen. "Reasoning, Problem Solving, and Decision Processes: The Problem Space as a Fundamental Category." *Technical Report CMU-CS-79-133*. CMU, June 1979.
17. Reddy, M. "The Conduit Metaphor." In *Metaphor and Thought*, Ortony, A., ed. Cambridge: Cambridge University Press, 1979.
18. Reiter, R. "On Closed World Data Bases." *Logic and Data Bases*. New York: Plenum Publishing Corp., 1981.
19. Rudin, L. "Lambda-Logic." *Technical Report 4521*. Pasadena, CA: California Institute of Technology, May 1981.
20. Selfridge, O. "Pandemonium: A Paradigm for Learning." *Technical Report JA-1140*. Cambridge: MIT, 1958.
21. Shapiro, E. "A Subset of Concurrent Prolog and Its Interpreter." *Technical Report TR-003*. ICOT, January 1983.
22. Smith, B. "Reflection and Semantics in a Procedural Language." *LCS-TR-272*. Cambridge, MA: MIT Laboratory for Computer Science, 1982.
23. Sussman, G. J., T. Winograd, and E. Charniak. "MICROPLANNER Reference Manual." *AI Memo 203*. Cambridge, MA: MIT Artificial Intelligence Laboratory, 1970.
24. Tarski, A. "The Semantic Conception of Truth." *Philosophy and Phenomenological Research* 4 (1944), pages 341-375.
25. van Emden, M., and R. Kowalski. "The Semantics of Predicate Logic as a Programming Language." *JACM* 23, No 4 (1976), pages 733-742.
26. Weyhrauch, R. "Prolegomena to a Theory of Mechanized Formal Reasoning." *Artificial Intelligence* 13, 1, 2 (April 1980), pages 133-172.
27. Winograd, T. "Procedures as a Representation for Data in a Computer Program for Understanding Natural Language." Cambridge, MA: MIT Project MAC, *MAC TR 83*, 1971.



# Meet The Princeton Graphics Systems Family.

**The right monitor at the right price.** Princeton Graphic Systems offers you a complete family of high performance personal computer monitors. Monitors that deliver the compatibility, resolution, and reliability you need for any application and any budget: from word processing to sophisticated business graphics.



**HX-12E.** High resolution RGB monitor -Compatible with IBM Enhanced Graphics Adapter -Nonglare screen -**\$785**



**MAX-12.** Amber monochrome -720 x 350 lines -Enhanced to interface with IBM color or monochrome adapter card -Nonglare screen -Can display 16 shades of amber -**\$249**

**HX-12.** High resolution RGB monitor -690 x 240 lines noninterlaced -.31 mm dot pitch tube-Nonglare screen -**\$695**



**HX-9/9E.** Nine inch, high resolution RGB monitor -.28mm dot pitch tube - 9E compatible with IBM Enhanced Graphics Adapter -Nonglare screen -Green/amber switch -Apple/IBM colors - Etched dark glass screen -**\$650/\$750 (9E)**



**SR-12P.** PGS's top of the line RGB monitor - Analog input allows for the display of 4,096 possible colors - Compatible with IBM Professional Graphics Adapter - Nonglare screen -**\$999**



**SR-12.** Super-high resolution RGB monitor -690 x 480 lines noninterlaced -.31 mm dot pitch tube - Nonglare screen - Requires interface card -**\$799**



**Princeton accessory product line.** Undergraduate tilt/swivel monitor base, ColorView card, Green/Amber switch, RGB-80 card and Scan Doubler card.

## Princeton Graphic Systems. The only real choice.

For office or home use, Princeton Graphic Systems has a monitor that's right for you. Inquire at your local computer store about our complete line of high resolution color and monochrome monitors; monitors that live up to the Princeton Graphic Systems 'tradition of quality, performance, and value. **Princeton Graphic Systems.** 601 Ewing Street, Bldg. A, Princeton, N.J. 08540. (609) 683-1660 Telex: 821402PGSPRIN (800) 221-1490. Ext. 504

# PRINCETON

GRAPHIC SYSTEMS  
AN INTELLIGENT SYSTEMS COMPANY

IBM IBM Enhanced Graphics Adapter, and IBM Professional Graphics Adapter are trademarks of International Business Machines, Inc. Compaq is a trademark of Compaq Computer Corp. Corona is a trademark of Corona Data Systems, Inc. Apple is a trademark of Apple Computer Corp. PC World is a trademark of CW Communications Inc.



# Make Stat Magic

Now for the IBM PC/AT\*  
with hard disk

## Statistics, reports and plots happen magically with SPSS/PC™—the Statistical Package for IBM PC/XTs.\*

SPSS/PC is the most comprehensive statistical package for performing simple or complex tasks, regardless of data size. It maintains feature and language compatibility with mainframe SPSS, while optimizing for the PC environment.

Statistics range from simple descriptive to complex multivariate, including Multiple Regression, ANOVA, Factor and Cluster analysis. Loglinear and nonparametric procedures are also included.

Simple facilities allow transfer of files between

SPSS/PC and programs like Lotus 1-2-3, dBase II and SAS. A complete Report Writer, Plotting facilities and a Communications program for mainframes round out a fully integrated product.

For more information, contact our Marketing Department without further ado. And see what a little stat magic can do for you.

SPSS Inc., 444 N. Michigan Avenue,  
Chicago, IL 60611, 312/329-3500.

In Europe: SPSS Benelux B.V.,  
P.O. Box 115, 4200 AC Gorinchem,  
The Netherlands, Phone: +31183036711  
TWX: 21019.

VISA, MasterCard and  
American Express  
accepted.



**SPSS inc.** PRODUCTIVITY RAISED TO THE HIGHEST POWER™

\*SPSS/PC runs on the IBM PC/XT or AT with 320K memory and a hard disk. An 8087 co-processor is recommended. Contact SPSS Inc. for other compatible computers.

IBM PC/XT and AT are trademarks of International Business Machines Corporation. dBase II is a trademark of Ashton-Tate. 1-2-3 is a trademark of Lotus Development Corporation. SAS is a registered trademark of SAS Institute, Inc. SPSS and SPSS/PC are trademarks of SPSS Inc. for its proprietary computer software. © Copyright 1985, SPSS Inc.

## VISION

BY DANA H. BALLARD AND CHRISTOPHER M. BROWN

### *Biology challenges technology*

VISION AND MOTOR CONTROL are such common capabilities in the animal kingdom that we do not usually associate them with intelligence. Yet vision has always been a paradigm problem for artificial intelligence (AI), since it is mysteriously difficult. Technology has mounted many responses to the biological challenge of reliable, versatile, real-time vision systems, but so far the resulting industrial systems only work in specialized settings (or domains). These systems are routinely used to inspect integrated circuits and manipulate parts but cannot be used outside of these limited contexts. For example, the systems' image input is binary (black and white), not the full gray-scale range provided by an input device such as a TV camera. Attaining such an image calls for carefully engineered lighting and imaging conditions. Also, to attain the necessary speed, the systems have simple algorithms that will not tolerate events such as parts obscuring one another or lying propped up at odd angles. A seemingly simple but elusive industrial vision task, beyond the capability of all current systems, is the "bin-picking" problem, one regularly surmounted by humans: It involves sim-

ply grasping and removing parts jumbled together in a bin, not laid out flat on a special surface.

Thus, fast, reliable computer vision is so hard that we can presently achieve it only in highly constrained and simplified domains. This makes the fast and reliable vision performed by biological systems all the more marvelous and mysterious. Somehow, humans perform recognition, description, manipulation, and locomotion in a highly complex world of moving solid objects, both rigid and nonrigid, with complex (textured, transparent, glossy, etc.) surfaces and highly variable illumination conditions.

General-purpose vision systems, which can build descriptions of their environment in general situations, remain a research goal. Today, a consensus is emerging that such systems will be designed around two central ideas, originating in biology and rediscovered by researchers in technology. The embodiment of these ideas in vision systems is a topic of much current concern and an area of rapidly expanding technological achievement and biological insight.

The first idea is that vision systems use a hierarchy of representations

that develops visual information in many intermediate stages to span the gap from input signal to cognitive symbols. Computer-vision researchers found the hierarchy to be a solution to several technical problems of computing and storage efficiency. Currently, researchers in the neurosciences are studying the extent of such a functional and physiological hierarchy in biological systems, and many signs point to biological versions of the computer-vision hierarchy.

The second idea is parallel computation. Researchers have known for a long time that nervous systems compute in parallel, and they have made many attempts to model such computations. Recent work has provided new tools in these areas (see the articles in this issue "Learning in Parallel Networks" by Geoffrey E. Hinton on page 265 and "Connections" by Jerome A. Feldman on page 277) and powerful parallel computing engines are now realizable. In the remainder

*(continued)*

Dana H. Ballard is an associate professor and Christopher M. Brown is the chairman of the Department of Computer Science, University of Rochester (Ray P. Hylan Building, Rochester, NY 14627).



of this article, we will explore the two themes of representational hierarchy and parallelism in computational and biological vision.

**HISTORY AND BACKGROUND**

The digital analysis of visual input has been a research issue since the late 1950s when computers became large

enough to accommodate such data. After about a quarter of a century of development, computer vision is a large subfield of AI. Like robotic control and computer-speech analysis, computer vision often uses "real" data—that is, the raw output of sensors—as its input. However, computer vision also uses more symbolic

or processed data. Thus, one vision program can have, for example, an array of gray-level intensities from a television image as input, while another program may take a symbolic description of a line drawing as input.

The goals of computer vision are also diverse but may be characterized as seeking answers to "what," "where," and "why" questions. "What" questions concern the identification of objects in a scene; "where" questions involve the perception of the environment in time and space; and "why" questions address causal relationships between objects.

True computer vision, with the goal of understanding images of complex three-dimensional scenes, was first attempted in the early 1960s by Larry Roberts at MIT (see reference 1). His goal was to "understand" a scene made up of polyhedral blocks, in the sense of being able to produce a line drawing of the scene from any viewpoint. Roberts's system pioneered many fundamental techniques still in use today, not just in computer vision, but also in computer graphics. In particular, the system analyzed digitized input images by identifying "edge elements" that might line up along the polyhedral edges (see figure 3b for an illustration of this technique in another application). The system then fused these edge elements to produce longer lines that corresponded to the polyhedral edges (figure 3c again is similar) and matched the resulting line and polygon data structures against three-dimensional models of primitive blocks. This process derived the scaling, rotation, and translation of the models needed to explain the image data, and this information allowed the system to produce the final line drawings, using basic computer-graphics techniques—also first attempted by Roberts—such as hidden-line removal.

Roberts's goal was ambitious even by today's standards: No computer vision system will perform the task of reliably identifying blocks on a table in the presence of occlusion and noise. However, such early work

(continued)

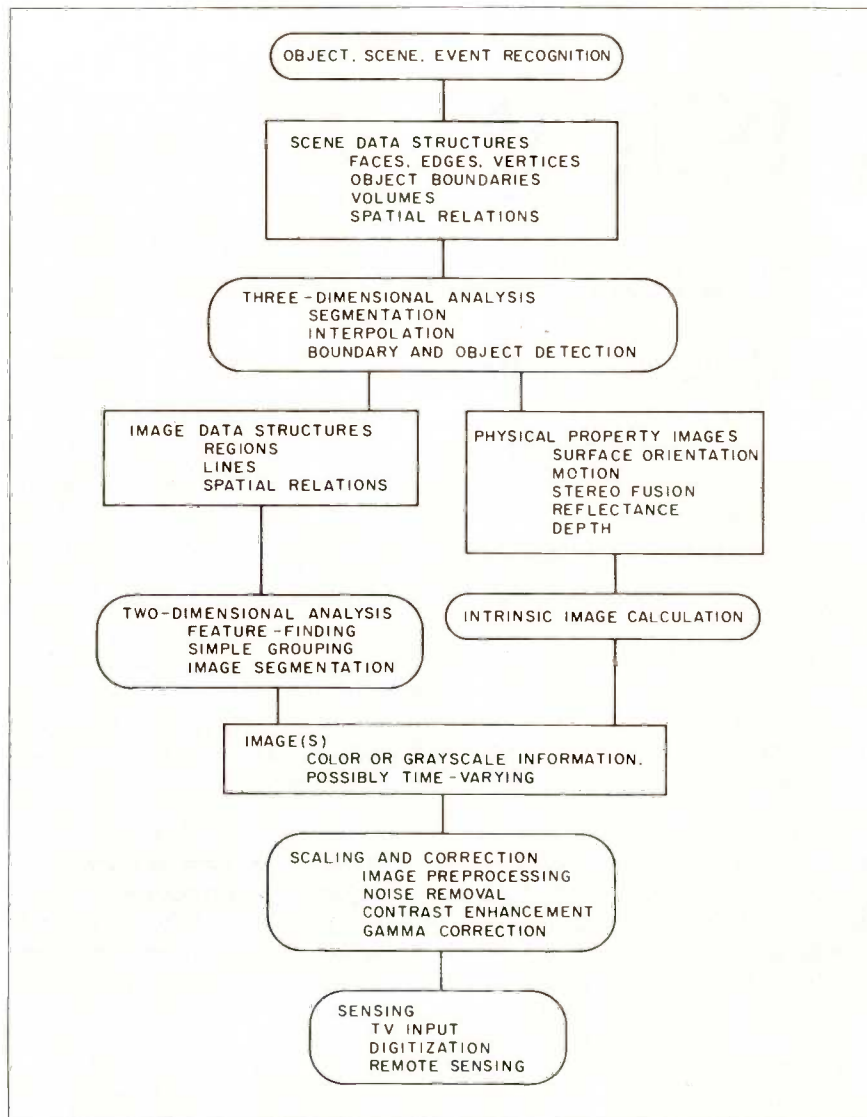

Figure 1: The processes (ellipses) and data representations (rectangles) of a general computer-vision system. Processing can proceed from input data to symbolic description (a normal data-driven scheme) or in the reverse direction (where expectations guide processing). Control is most often thought to flow in both directions. Each stage of processing includes assumptions about how the image information is related to the phenomena of interest in the world. In natural systems these assumptions may be innate or learned.

# 3 USERS ON ONE CARD!

IF you own an S-100 system...

IF you need to expand to a  
Multi-User system...

IF you are using TURBO DOS or  
NETWORK/OS...

You can get 3 users on a single  
S-100 slave card! And pay the  
price of One!

# A 16-BIT MS-DOS COMPATIBLE BOARD

Advanced Digital is proud to present its latest state of the art SUPER 16 S-100 slave board. Using intel 80186 (8MHz) and 256K Bytes of memory and 4 serial I/O ports, now each user in a multi-user environment can have a dedicated 16 bit system running. The SUPER 16 is designed to run with all of the INDUSTRY STANDARD S-100 master 8/16 Bit. Operating systems supported are TURBO-DOS & NETWORK/OS.

ADVANCED DIGITAL manufactures a complete line of S-100 Boards and Systems and PC add on products. Turbo-Dos is a trademark of software 2000. Network/OS is a trademark of CBIS. Multislave and super 16 are trademarks of ADC. MS-DOS is a trademark of MicroSoft.

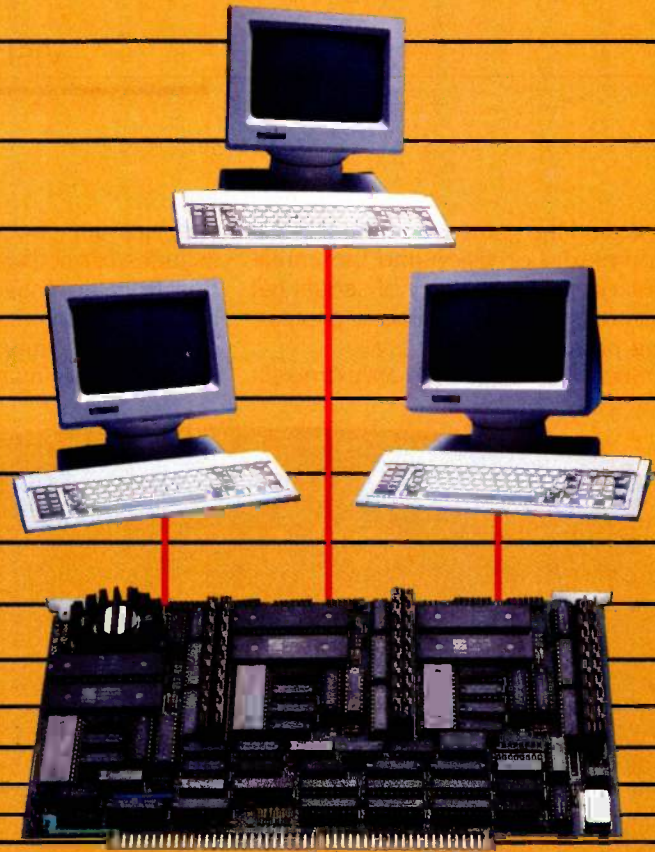

Multislave

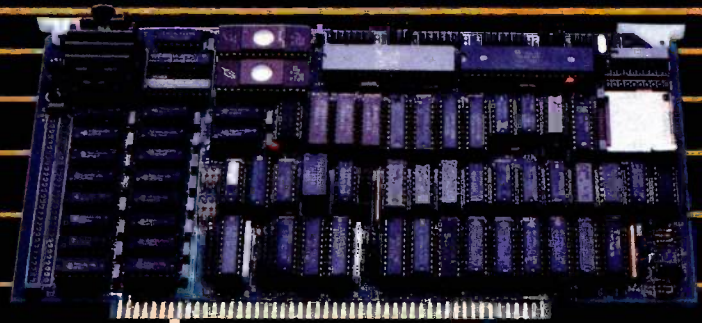

**Advanced Digital Corporation**  
5432 Production Dr., Huntington Beach, CA 92649  
(714) 891-4004—Telex 183210 ADVANCED HTBH

**Advanced Digital U.K. Ltd.**  
27 Princes St., Hanover Square  
London W1R8NQ—United Kingdom  
(01) 409-0077/(01) 409-3351—Telex 265840 FINEST

**ADVANCED  
DIGITAL  
CORPORATION**



revealed the immense computational complexity of vision and the unreliability and inadequacy of sequential control structures to allocate processing power.

Such a task requires an extraordi-

nary amount of computation, which includes extracting physical information from an image, labeling image regions that correspond to significant objects, and symbolically describing objects in the image.

Thus the field of computer vision is quite large. It includes the aforementioned industrial inspection systems, as well as academic research efforts whose competence (what we must know to solve a problem) is often of more interest than their performance (how we actually solve the problem in real time). See the bibliography at the end of this article for more material on the field of computer vision.

In the 1970s a cognitive approach to computer vision arose, which conveniently minimized image-level computation and emphasized the symbolic manipulations to which computers are well adapted. In such "knowledge-directed" vision, processing uses facts about such phenomena as gravity, support, occlusion, or the likely spatial relations between objects in the scene. Research turned toward representing and manipulating facts about a particular setting (or *domain*, such as a grouping of polyhedral blocks or an office scene) and exploiting the domain-specific knowledge in vision.

However, the representation and application of knowledge is a very difficult branch of AI, and the available techniques proved inadequate to bridge the gap between the input image and the desired symbolic descriptions of it. Thus in 1974, starting with Marr at MIT and Barrow and Tenenbaum at Stanford Research Institute, attention was directed toward a collection of intermediate representations, termed *intrinsic* images, that would span the representation gap.

Today, the consensus of the computer-vision community is that this gap is bridged by a set of visual data representations that are arranged in a hierarchy of increasing abstraction.

#### VISION AND THE ABSTRACTION HIERARCHY

Our vision is quite reliable—that is, there is a good correlation between our perceptions and things in the world. Otherwise, we would not have survived as a species. How do we ignore irrelevant variations and concentrate on those that mean something?

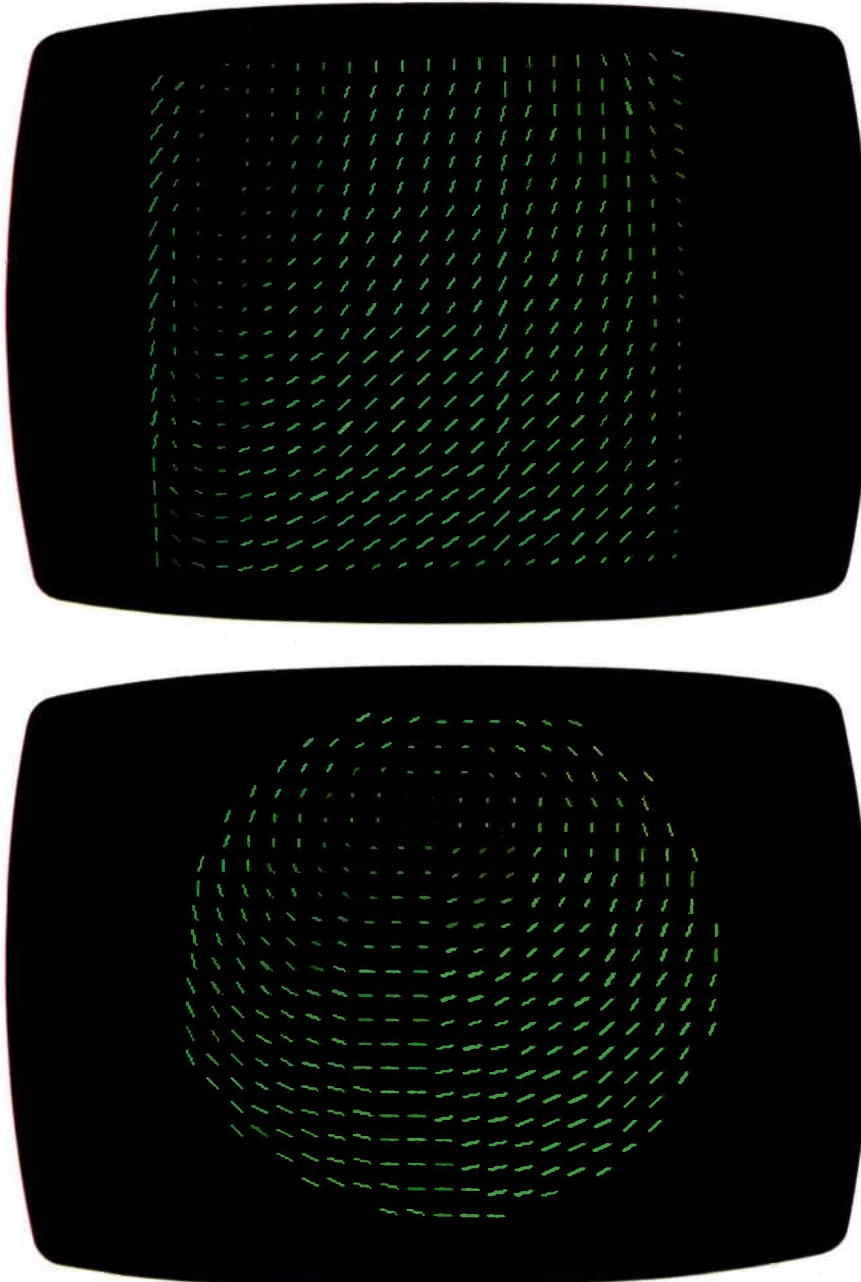

Figure 2a: Optic flow images (retinal pattern velocities caused by scene motion) from a rotating sphere and cylinder.

How do we achieve the constancies whereby we recognize objects under varying illumination, or faces at different ages? How do we perform so fast and reliably? A partial answer to these questions is that of abstraction hierarchies.

Modern computer vision spans the gap between input image and object perception with a hierarchy of representations (the aforementioned intrinsic images) operated on by powerful computational processes (as shown in figure 1). These processes create representations that pass from image-like representations of physical parameters to symbolic descriptions. Constructing these intermediate descriptions is feasible and probably necessary, but it involves complex computations for a general vision system (as opposed to a highly specialized system, such as an industrial system).

At the earliest level (the input level), a general vision system derives a representation of image brightness changes that it uses for stereo disparity calculations (the difference between two views of the same setting), detecting changes in surface composition, orientation, distance, reflectance, and so forth. Perceptual phenomena (e.g., subjective contours, the ability to discern colinearity of dissimilar shapes) suggest components for the earliest image representations (e.g., locations, orientations, and endpoints of features). Feature detectors that derive these components may then be designed by humans.

Much current research is centered around the production of physical property images, which are intermediate representations that the system forms before attempting object recognition. These image-like representations are registered with the input image and contain values of physical parameters of scene points such as the distance from a sensor to the point, the albedo (reflective power) of surfaces, the objects' direction of motion, the location of shadows and light sources, and so forth. Researchers generally assume that the processes producing physical

property images are part of "early vision." That is, they are not dependent on the context of the scene being viewed, much less on conscious reasoning, but are robust general processes that produce reliable output in

a broad range of natural circumstances. However, these processes cannot be *completely* general and reliable, since the two-dimensional input image does not capture three-

(continued)

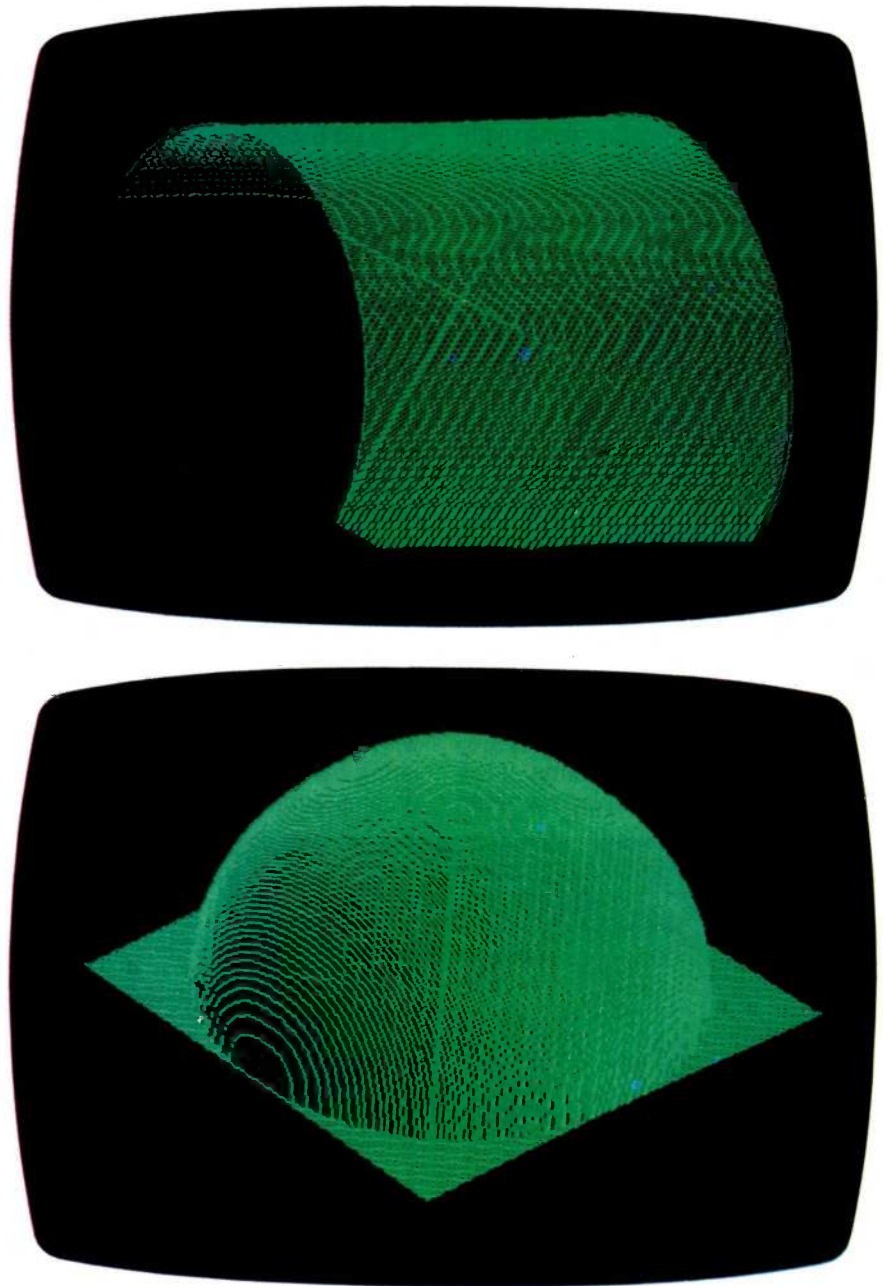

Figure 2b: Shapes causing the images as derived by a computational vision process. Such processes use mathematical models of physical laws and assumptions about nature to recover physical information about scenes from input images. [Courtesy of John Aloimonis, University of Rochester.]



dimensional information directly (it can only imply it). But the usual reliability of these processes in animal vision implies that they rely on natural constraints or assumptions about the world to derive unambiguous output. Identifying and using such constraints are important goals of modern computer-vision research. This, in turn, calls for seeking out properties of the physical world that could help a visual process do useful work, making mathematical models of their interaction with visual phenomena, and implementing the mathematics in computer programs. One such result that illustrates the kind of computations at this level is the computation of relative depth from optic flow (see figure 2).

The step beyond intrinsic images is a large one; although they contain physical information, they are still image-like entities not yet described in terms of objects. Two of the most important visual phenomena are motion and texture, which transmit much information about the objects and surfaces in a scene. One of the most active areas of computer-vision research is the extraction of information from motion or from optic flow of the visual field on our retina as an object or the viewer moves. It is also a particularly good illustration of the symbiosis that can take place between

psychology and computer vision.

Researchers basically agree that the higher abstraction levels in a general computer-vision system must contain data structures representing aspects of the domain from which the scene originates. The resulting problems in knowledge representation are interesting in a wide variety of AI applications. For example, computer modeling of three-dimensional rigid solids is by no means a solved problem except for certain manufactured objects. Also, representing naturally occurring shapes and volumes so that they can be matched to their geometric counterparts in intrinsic images is still an open question.

High abstraction levels pose several other difficulties. Perception goes on through time, and yet representing processes through time is an area of advanced AI research.

The contribution of high-level knowledge and inferential procedures to the vision process is still a mystery. It seems certain that information does not simply flow "bottoms up" (that is, sequentially, from low-level to high-level) through the visual system, as it did in Roberts's first system. Nor is vision merely controlled hallucination, with the abstract representations dictating our perceptions as they do in dreams, subject to minor corrections

from incoming data. The upper levels of abstraction hierarchy must support information flow in both directions, and a bottleneck in current computer-vision research is achieving useful interaction between the lower, image-like representations and the higher, symbolic ones.

### STATE-OF-THE-ART EXAMPLES

Two examples will illustrate the operation of computer vision in the sort of abstraction hierarchy introduced in the last section. The three-dimensional MOSAIC system at Carnegie-Mellon University, developed by Marty Herman and Takeo Kanade, can reconstruct three-dimensional representations of buildings from two aerial views—using stereo to provide depth information—or from a single view—using advance knowledge about the nature of the input scene to provide depth information. Figures 3a through 3d show the operation of the monocular version of the algorithm.

The MOSAIC system uses an edge operator to find intensity discontinuities, which contain much image information in a single input image (see figure 3a). Because the image has a baffling number of such "edge elements," the system sends the output to a post-processing routine that identifies edges that are likely to con-

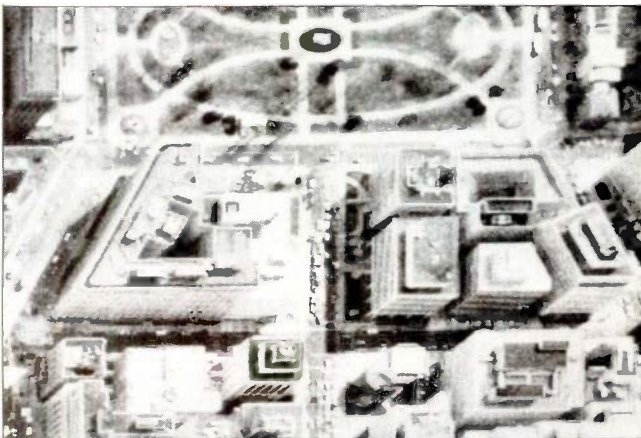

Figure 3a: Aerial view of a city park and buildings provided as a single input image to the MOSAIC (see text) system.

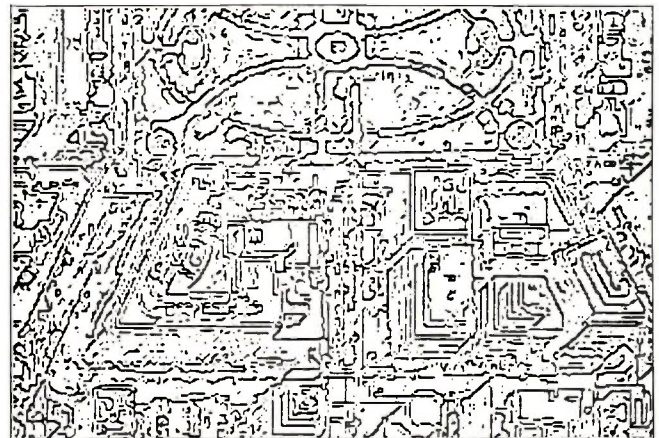

Figure 3b: Output of an edge-finding algorithm applied to the image of figure 3a.

tribute to interesting structures in the image (see figure 3b). Several stages of processing then link the edges into two-dimensional structures using standard edge-linking technology and information about the way lines meet to form vertices in polyhedral scenes. And then the edges are linked into three-dimensional structures—using information about gravity, support, the perspective imaging process, and other facts describing the physical scene domain and the optics of image formation. Figure 3c shows the result of this processing: a perspective view of a three-dimensional "wireframe" representation of edges in the scene.

The next stage of processing relates the wireframes to stored representations of three-dimensional solid models. In a sense, the solid models are the final output of the program, with two important additions. First, the system can relate new image information to its existing model data structures, which it can refine as it acquires the new images. Second, the system can, using standard computer-graphics technology, map the flat image onto the surfaces of the stored three-dimensional models. The system can then display three "painted" models from another angle, as shown in figure 3d.

Work continues on the extraction

and identification of meaningful parts of an image. This process is called *segmentation*, which is typified in the VISIONS (Visual Integration by Semantic Interpretation of Natural Scenes) system at the University of Massachusetts. The VISIONS system's sophisticated programs use models of a specific domain (rural, outdoor scenes of houses, trees, etc.) and knowledge about that domain.

In this work, the goal is to segment a color image (as in figure 4a) into regions that correspond to meaningful objects or substances in the image. The process involves extracting straight lines (see figure 4b), and regions of related color characteristics (see figure 4c). The VISIONS system uses interpretation rules that incorporate knowledge about the scene domain (for example, that a driveway is not found silhouetted against the sky, or that a house's roof is above its walls) in cooperation with the image-guided segmentation processes. These interpretations make the segmentation process more reliable, by indicating, for example, when regions may be merged or should be split. For example, in figure 4c the system has colored regions that it has hypothesized, using interpretation rules, to be shutters. Foliage is an important component of these scenes,

and VISIONS has a set of feature extractors and recognizers to allow reliable identification of foliage, despite its many different appearances.

Figure 5 shows the final labeling of another input scene, with regions identified as sky, foliage, grass, wall, shutters, roof, and regions (in black) that are uninterpreted due to the lack of a symbolic model in the current system or deviation of the scene's appearance from that predicted by the model. VISIONS currently models some 20 major objects and object collections such as "house" and "house scene," and a larger number of object parts such as "roof" and "shutters."

The two examples of current systems show the beginning of understanding the competence issues in vision: We know what kinds of entities need to be computed. However, each of these examples requires huge amounts of computer time. Most researchers believe that the performance problem in vision will only be solved through parallel computation.

## CHALLENGES FROM ANIMAL VISION

One of the most promising directions for the study of parallel processing has centered around studies of

(continued)

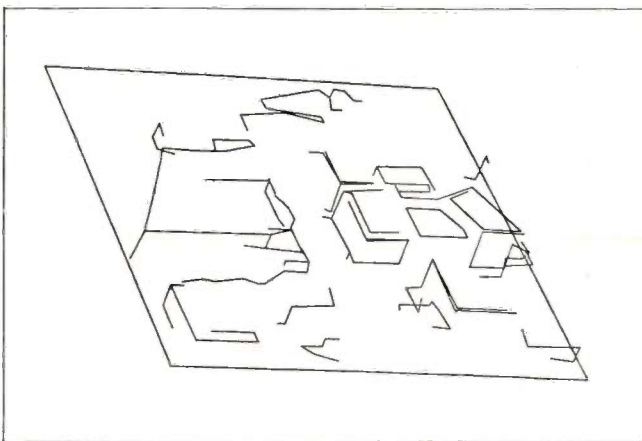

Figure 3c: A "wireframe" of linked line segments in three dimensions resulting from several sorts of processing applied to the data of figure 3b.

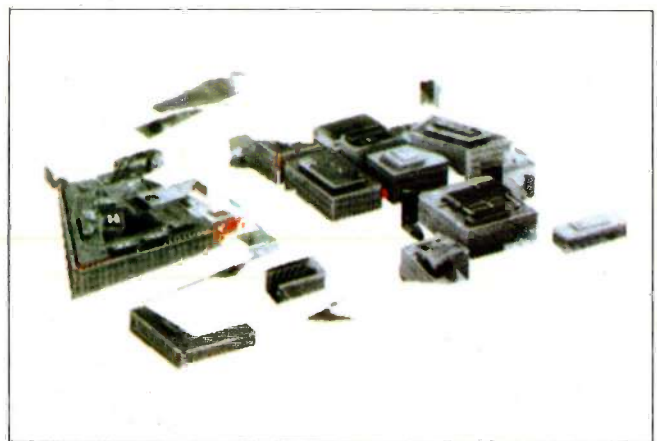

Figure 3d: Computer-graphics techniques use the original photo and the three-dimensional models extracted by further processing of the wireframe data of figure 3c, resulting in a convincing reconstruction of the scene. [Courtesy of Marty Herman and Takeo Kanade at Carnegie-Mellon University.]



human and animal vision. Unlike robot vision, where many of the complexities of sensing the environment can be manipulated by tailoring the environment and using special imaging techniques, animal vision must somehow analyze time-varying photometric data in its full complexity in real time. Furthermore, biological systems use neural-processing elements that are six orders of magnitude slower than silicon components.

Despite all these apparent disad-

vantages, animal systems succeed admirably. Experiments with human subjects show that they can make a variety of behavioral responses to visual stimuli in a few hundred milliseconds. Thus, the biological system, somewhat embarrassingly, embodies solutions to problems that still plague vision researchers. This situation has lured researchers to tackle the problem of modeling the human visual system head-on, in the hopes of discovering its secrets. Such researchers

typically have a wide range of cross-disciplinary interests and are joining to make progress in the separate fields of psychology, neuroscience, and computer science. We shall describe some of the more interesting of the many new results from these disciplines.

Since humans are very good at visual tasks, researchers were surprised to find that, for some tasks, information can be processed in parallel, but for rather modest increases in complexity, the processing became sequential (see reference 2). Treisman describes visual displays of letters about which subjects were asked questions of the form "Does the display contain a T?" (See figure 6.) Most subjects can answer this question in a few hundred milliseconds, independent of the number of letters displayed (see the lowest dashed lines of figure 6). However, if we change the question to "Does the display contain a *red* T?" the time taken to answer becomes linearly dependent on the number of letters displayed. From this we conclude that the brain processes certain primitive features in parallel but processes conjunctions of these features serially.

We still lack a detailed explanation for this result, but one hypothesis is as follows. It may be uneconomical for the visual system to check stored prototypes against spatial positions. A faster way would be for the brain to build an abstract representation that is independent of the precise point in space where the feature is located. Thus, we hypothesize that the brain builds a representation for a T if there is one or more Ts anywhere in the visual field. In a similar process, the brain builds a representation for perceived color values, such as "red." Thus, the brain could answer questions concerning these features directly. In contrast, questions about conjunctions of features cannot be handled by this scheme, since information about spatial location is not present in the abstract representation. One idea, termed the *searchlight hypothesis* (see reference 3), is that the brain

(continued)



(4a)



(4b)



(4c)

Figure 4: (a) An outdoor scene to be analyzed by the VISIONS computer-vision system. (b) Straight lines extracted from the data of 4a. (c) Regions extracted from the data of 4a.

**New Version**

# Classic COBOL.

True mainframe COBOL for your microcomputer. Validated by the GSA at the highest possible level of compliance with the ANSI '74 standard. With Microsoft® COBOL, mainframe programmers can be productive on MS-DOS™ and Microsoft XENIX® microcomputers immediately.

## Speed and Beauty.

High performance in a COBOL program comes mostly from the speed of the ISAM. And Microsoft COBOL 2.0 has the fastest ISAM on the market.

And our advanced screen handling capability lets you create the highly interactive programs that end users prefer.

## We wrote the book.

It's no surprise that IBM®, DEC®, AT&T, H-P and Wang® all chose Microsoft COBOL for their MS-DOS machines. We know how to get the most out of their microcomputers. After all, we designed the operating system.

So call (800) 426-9400. In Washington State, Alaska, Hawaii and Canada, call **MICROSOFT**® (206) 828-8080. The High Performance Software™ We'll give you the name of your nearest Microsoft dealer or help you update to Microsoft COBOL 2.0.

### Certified High Level Compiler:

- GSA validation at the Federal High Level of compliance with the ANSI '74 standard.
- Built in sort-merge, chaining, dynamic calling, and overlays.

### Fast multi-key ISAM:

- Split-keys and duplicate keys.
- Benchmark results of 5000 reads and writes to an ISAM file:

	Microsoft COBOL 2.0	Realia COBOL	MicroFocus® Native Code	Ryan-McFarland® COBOL 2.0
hours:				
minutes	1:32	1:56	2:58	3:30

### Interactive extended screen section:

- Cursor positioning, auto skip, automatic data field formatting.
- ACCEPT and DISPLAY data by the screen full.

### Productivity utilities:

- Interactive Symbolic Debugger.
- Rebuild file recovery utility restores corrupted ISAM files.

### Price:

- \$700 for compiler and utilities.
- No runtime royalty fees.

### Minimum System requirements:

- MS-DOS 2.0 or later, 192K RAM, and one disk drive.
- Xenix 286, 512K RAM, and one disk drive.



Microsoft and Xenix are registered trademarks and The High Performance Software is a trademark of Microsoft Corporation. IBM is a registered trademark of International Business Machines DEC is a registered trademark of Digital Equipment Corp. Wang is a registered trademark of Wang Laboratories, Inc. MicroFocus is a registered trademark of MicroFocus. Ryan-McFarland is a registered trademark of Ryan-McFarland.





# BEST SAVINGS IN U.S.A.

CALL TOLL FREE  
**1-800-428-7979**

"LAST CALL FOR SAVINGS"  
FREE \$20 PRINT WHEEL\*

## PRINTERS • PLOTTERS

	List	Sale
<b>Epson</b>		<b>Call</b>
<b>Enter</b>		
Sweet-P 6 Pen Plotter (HP)	\$1095	<b>\$739</b>
<b>Inforunner (Epson Exact)</b>		
Rileman Blue Macintosh & Cable 140CPS	\$549	<b>Call</b>
Rileman Blue Plus 140CPS (IBM)	499	<b>\$272</b>
Rileman Plus 120CPS	399	<b>Call</b>
Rileman 15 160CPS (FX100 Exact)	799	<b>Call</b>
Rileman II 160CPS (FX80 Exact)	549	<b>Call</b>
Rileman Letter Quality 12CPS	299	<b>209</b>
<b>Juki</b>		
6100 Letter Quality Daisywheel 18CPS	\$599	<b>Call</b>
6300 L.Q. Daisywheel 40CPS	995	<b>\$679</b>
<b>Legend (Square Dot, Epson Compatible)</b>		
880 100CPS-ART	\$279	<b>Call</b>
1080 120CPS-ART	339	<b>Call</b>
1380 160CPS-ART (IBM)	359	<b>\$279</b>
1385 160CPS-ART (IBM) 15" wide	449	<b>Call</b>
1800 180CPS 7-Color (IBM) 15" wide	1195	<b>Call</b>
<b>*Silver Reed (Free Print Wheel-Ltd. Qty.)</b>		
EXP400 L.O. Daisywheel	\$399	<b>Call</b>
EXP500 L.O.	499	<b>\$289</b>
EXP550 L.O. 18CPS	649	<b>389</b>
EXP770 L.O. 36CPS	1295	<b>Call</b>
<b>Toshiba (3 in 1 Printers)</b>		
1340	\$995	<b>Call</b>
1351	1895	<b>Call</b>

## MODEMS • MONITORS • DRIVES

<b>Anchor Automation</b>		
Express 300/1200 (Hayes Exact)	\$439	<b>Call</b>
Mark XII 300/1200	399	<b>\$235</b>
Volksmodem 12 w/Cable	299	<b>199</b>
<b>Hayes (1200, 1200B)</b>		<b>Call</b>
<b>Novation (Hayes Compatible)</b>		
Smart Cat Plus 2400 Baud (IBM, MAC)	\$795	<b>Call</b>
Smart Cat Plus 1200 w/Mile (IBM, MAC)	499	<b>\$299</b>
<b>Practical Peripherals (Encryption)</b>		
DES 2000 (Data Encryption System)	\$459	<b>Call</b>
<b>Zoom (Hayes Compatible)</b>		<b>Call</b>
<b>Amdek</b>		<b>Call</b>
<b>Princeton Graphic</b>		<b>Call</b>
<b>Taxan</b>		
116 Amber	\$179	<b>\$115</b>
122 Amber (IBM)	229	<b>131</b>
420 RGB (IBM) HI-RES w/Cable	579	
425 RGB 12" (IBM)	609	<b>Call</b>
440 RGB 12" (IBM-ULTRA-RES)	799	<b>Call</b>
<b>Kodak - Drives</b>		
3.3 MEG 5 1/4 Disk (IBM) Internal 1103	\$945	<b>\$698</b>
<b>Shugart (100% Macintosh)</b>		
3.5" Micro Floppy External	\$399	<b>\$319</b>

## COMPUTERS • CARDS

<b>NEC (8401, 8201, Computers)</b>		<b>Call</b>
<b>Paradise</b>		
Modular Graphics Card	\$395	<b>\$269</b>
Fivepack	229	<b>155</b>
<b>Zenith (PC's)</b>		<b>Call</b>

## SOFTWARE • DISKETTES

<b>CPA*</b> (For Lotus 1-2-3) GL, AP, AR, PR	\$695	<b>Call</b>
<b>Enable</b>	\$695	<b>Call</b>
<b>Lotus 1-2-3</b>		<b>Call</b>
<b>Micropro</b>		
WordStar	\$350	<b>\$172</b>
WordStar Pro	495	<b>235</b>
WordStar 2000	495	<b>Call</b>
WordStar 2000*	595	<b>Call</b>
<b>Practicorp (IBM)</b>		
Practword/Base/Calc III Integrated		<b>\$189</b>
Above each separate		<b>69</b>
<b>Maxell (100 Diskettes) IBM, MAC, HP</b>		<b>Cheap</b>
<b>Fuji (100 Diskettes) IBM, MAC, HP</b>		<b>Cheap</b>

## MINORITY HI-TECH INDUSTRIES

5021 N. 20th Street, #10261  
Phoenix, Arizona 85064

Other Information: (602) 890-0596



Prices reflect 3-5% Cash Discount. Shipping on most items \$3.00. Prices and availability subject to change without notice. Send cashier's check or money order. All other checks delay shipping 2 weeks. ADD #185

## VISION



Figure 5: Regions extracted and labeled by VISIONS for another house scene. [Figures 4 and 5 courtesy of Allen Hanson, Edward Riseman, and the VISIONS project at the University of Massachusetts.]

sequentially focuses on spatial locations from which the features are derived. In this manner, if the "T" feature and the "red" feature occur together, then the question can be answered affirmatively. The separation of data into two different levels of abstraction (spatially organized and nonspatially organized) seems to be a fundamental design decision that allows the brain to do its job quickly.

Mishkin and colleagues performed another experiment that points to this organization (see reference 4). They made selective lesions in different parts of a monkey's cortex. Monkeys with lesions in one area of the brain performed a feature-recognition experiment at chance levels (in a statistically random manner) but had no trouble with a spatial-location experiment. In contrast, monkeys with lesions in another area performed a spatial-location task at chance levels

but had no trouble with a feature-recognition experiment. This startling result shows that an important psychophysical property may have a distinct locus in animal brains.

## CODING PHYSICAL CONSTRAINTS AS HARDWARE

Concurrent with these biological and psychological results, researchers in computer vision have been exploring parallel models of computation that handle features in similar ways. In addition, these models have to grapple with many difficulties of noise and missing information: A shape outline or a feature like a straight line is only represented in an image by partial and conflicting evidence mixed with confusing noise.

To overcome this problem, we use the Hough transform (see reference 5). The Hough transform includes a

(continued)

**New Version**

# Mighty Macro Assembler.

The new Microsoft® Macro Assembler package. A complete development environment that makes you a more productive programmer. Whether you're using Macro Assembler or any Microsoft high level language.

A common calling convention lets you easily call assembly language routines from any high level Microsoft language to add an extra burst of blinding speed.

## Better Debugging.

The new Symbolic Debug Utility lets you stay close to the source. Now you can step through your assembled or compiled code by name rather than by address. Source level display for Microsoft Pascal, FORTRAN, and C allows you to view both your original source and the resulting code.

And we stuffed our package with a full set of the most useful utilities around. So that you can link, maintain and organize your programs like never before.

Who else but Microsoft could build so much into one package for \$150?

For the name of your nearest Microsoft dealer call (800) 426-9400. In

Washington State, Alaska, Hawaii and Canada, call (206) 828-8088. And if you're already using Microsoft **MICROSOFT**® The High Performance Software™ or IBM® Macro Assembler, ask us how you can upgrade to the mightiest Macro of them all.

### Microsoft Macro Assembler Package:

#### Macro Assembler

- For the 8086/8087/8088 and now the 186/286/287.
- Define macros.
- Conditional Assembly.
- Case sensitivity for symbols.

#### New Interactive Symbolic Debug Utility

- Controlled testing environment for debugging.
- Source line display of Microsoft FORTRAN, Pascal and C Programs.
- Set breakpoints on line numbers and symbols.
- Single step to follow program execution.
- Disassemble object code.
- Display values.
- Make minor changes without reassembling.

#### New Program Maintenance Utility

- Rebuilds your applications after your source files have been changed.
- Similar to UNIX™ Make utility.

#### Library Manager

- Create, organize and maintain your object module libraries created with Microsoft Languages.
- Set page size (default of 16 bytes).

#### Object Code Linker

- Simple overlaying linker combines relocatable object modules created using Microsoft Languages into a single program.
- Load Map generation.
- Specify from 1 to 1024 segments.

#### Cross Reference Utility for the Macro Assembler

- Creates a cross-reference listing of the definitions and locations of all symbols used in an assembly language program.



**SOFTWARE**

Microsoft is a registered trademark and The High Performance Software is a trademark of Microsoft Corporation. IBM is a registered trademark of International Business Machines. UNIX is a trademark of Bell Laboratories.



# DeSmet C

8086/8088  
Development  
Package **\$109**

## FULL DEVELOPMENT PACKAGE

- Full K&R C Compiler
- Assembler, Linker & Librarian
- Full-Screen Editor
- Execution Profiler
- Complete STDIO Library (>120 Func)

## Automatic DOS 1.X/2.X SUPPORT

BOTH 8087 AND S/W FLOATING POINT  
OVERLAYS

## OUTSTANDING PERFORMANCE

- First and Second in AUG '83 BYTE benchmarks

**SYMBOLIC DEBUGGER \$50**

- Examine & change variables by name using C expressions
- Flip between debug and display screen
- Display C source during execution
- Set multiple breakpoints by function or line number

**DOS LINK SUPPORT \$35**

- Uses DOS .OBJ Format
- LINKs with DOS ASM
- Uses Lattice<sup>®</sup> naming conventions

Check:  Dev. Pkg (109)  
 Debugger (50)  
 DOS Link Supt. (35)

SHIP TO: \_\_\_\_\_

ZIP \_\_\_\_\_

**CW ARE**  
CORPORATION

P.O. BOX C  
Sunnyvale, CA 94087  
(408) 720-9696

All orders shipped UPS surface on IBM format disks. Shipping included in price. California residents add sales tax. Canada shipping add \$5, elsewhere add \$15. Checks must be on US Bank and in US Dollars. Call 9 a.m. - 1 p.m. to CHARGE by VISA/MC/AMEX.

Street Address: 505 W. Olive, #767, (94086)

## VISION

wide variety of clustering histogram analysis and estimation strategies, all of which transform data so that phenomena of interest form clusters.

Consider an example using the Hough transform for line detection. To detect lines in an image we must first detect local intensity differences or *edges*. Figure 7a shows the Hough transform applied to the image of a

Rubik's cube, in which intensity differences could be caused by an actual edge of the cube, a shadow, a label, and so on. If we call the image  $f(x,y)$  and the horizontal and vertical intensity differences  $h(x,y)$  and  $v(x,y)$ , then one way to compute the intensity differences uses the values of neighboring picture elements in the

(continued)

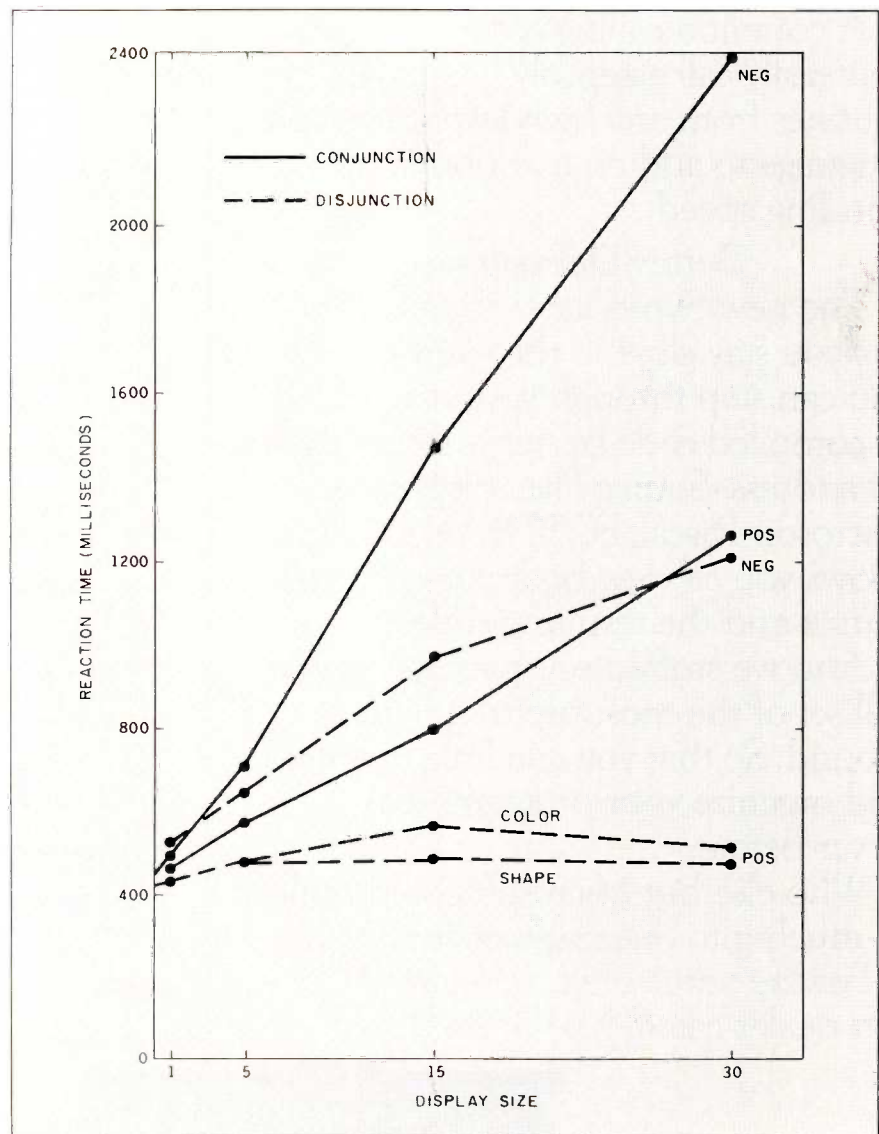

Figure 6: Reaction time in milliseconds for experiments described in text. In recognizing a single feature such as "red" or the letter "T", a subject's reaction time is constant if the feature is in the display (POS). If it is absent or, more importantly, if the stimulus is a conjunction (i.e., red T, depicted by a solid line), the response time increases linearly with the size of the display. [Figure taken from Treisman (see reference 2).]





following manner:

$$\begin{aligned}
 h(x,y) &= f(x+1, y-1) - f(x-1, y-1) \\
 &\quad + 2 \times f(x+1, y) - 2 \times f(x-1, y) \\
 &\quad + f(x+1, y+1) - f(x-1, y+1) \\
 v(x,y) &= f(x-1, y+1) - f(x-1, y-1) \\
 &\quad + 2 \times f(x, y+1) - 2 \times f(x, y-1) \\
 &\quad + f(x+1, y+1) - f(x+1, y-1)
 \end{aligned}$$

The edge finder reports an edge if the magnitude of the intensity differences ( $m = \sqrt{h^2 + v^2}$ ) is greater than a given threshold value. We will give the orientation of the edge as  $\theta$ , where  $\theta = \arctan(h/v)$ .

Next, we accumulate the local edges into straight lines. This accumulation is essentially a voting process, in which each edge element "votes" for the lines that could have caused it. Thus, in figure 7b, the edge element centered at the point  $(x_0, y_0)$ , with the orientation  $\theta$ , votes for a line that we can describe as  $(\rho, \theta)$ , where  $\rho = x \cos \theta + y \sin \theta$ .

After each edge element votes for the lines that could have caused it, the line with the most votes is presumed to be an actual line of the image, rather than an artifact or noise.

To facilitate this accumulation process, place all the values of  $(\rho, \theta)$  into another two-dimensional array, with  $\rho$

and  $\theta$  as coordinate axes (see figure 7c). The brightness of each cell in figure 7c is proportional to the number of edge elements voting for a line at that particular value of  $(\rho, \theta)$ . That is, the brighter the cell, the more likely the image actually has a line with those values of  $(\rho, \theta)$ .

To sum up, suppose the feature detector applied to a point  $(x, y)$  of the image responds with a local edge orientation  $\theta$  and a measure of edge contrast. Then one version of the algorithm is as follows.

For each point  $(x, y)$  in the image, do the following two steps:

- 1) Apply the detector to get  $\theta$  at  $(x, y)$
- 2) If edge contrast exceeds some threshold:

compute  $\rho = x \cos \theta + y \sin \theta$   
 increment LineParams  $[\rho, \theta]$

Several implementations of the Hough transform are possible (see reference 6). We have just described a straightforward sequential computer implementation that represents parameter space in an array. This representation is costly for transforms with multiple parameters, since it demands space exponential to the number of parameters—although re-

searchers have made progress in implementations of the accumulating parameter space (described above) using hash tables or content-addressable memories, which use less space.

Finally, the Hough transform can be implemented in massively parallel computing networks in which prewiring accomplishes all the voting in one time step.

The general notion of capturing functionality in terms of connection patterns is known as *connectionism* and is sparking a great deal of interest in different disciplines. One issue raised is computational. How is the computation carried out in very large networks with complex constraints? Recently, progress has been made by several groups headed by Kirkpatrick, Hopfield, Hinton, Sejnowski, Geman, and Geman (see references 7 through 10 and Geoffrey E. Hinton's article "Learning in Parallel Networks" on page 265). The thrust of this work is that constraints can be cast as local changes in "energy" and that the computing units can be turned on or off to minimize energy.

The neural network also shows a general way of representing informa-

(continued)

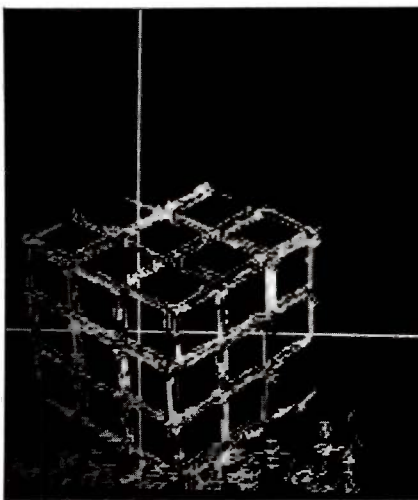

(7a)

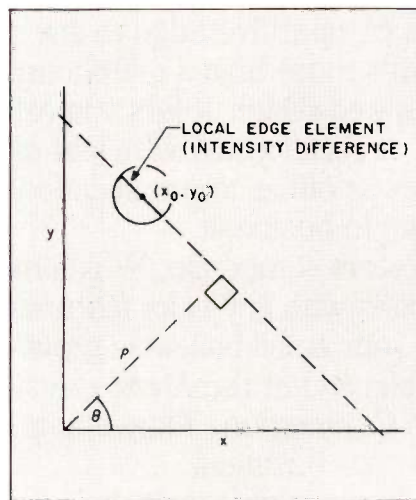

(7b)

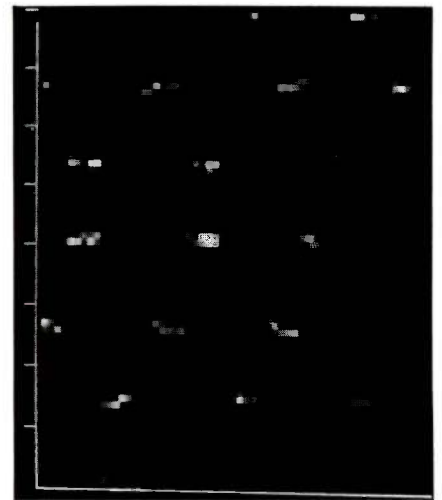

(7c)

Figure 7: (a) Results of applying a computer-vision edge operator to the image of a Rubik's cube. (b) The geometrical constraint that relates a local edge element  $(x_0, y_0, \theta)$ , shown by a circle, to a line, denoted by  $\rho$  and  $\theta$ . For every edge element in an image, a unique line can be determined. (c) Each edge element "votes" for the lines that may have caused it, as shown in this plot of  $\rho$  and  $\theta$  values. The brightest accumulations of values for  $\rho$  and  $\theta$  indicate the most likely lines in the actual image.

# Viasyn just lowered the cost of room and board.

CPU BOARD	THEN	NOW
8086/8087 5 MHz	\$1050	\$495
8086 10 MHz	\$ 800	\$395
8087 OPTION 5 MHz	\$ 495	\$175
8085/8088 8 MHz	\$ 495	\$275
8085/8088 10 MHz	\$ 545	\$350
68000 10 MHz	\$ 750	\$425
80286 C STEP	COMBO WAS	\$995
80287 OPTION 5 MHz	\$1595	\$375
32016 6 MHz	N/A	\$895
Z80	\$ 325	\$275

And, as you can see from the chart, we lowered it substantially.

Now you can get the finest room and board with CompuPro® CPUs, recognized as the highest-performing, most reliable products you can buy. And you can buy them at the lowest possible cost in the industry. You can even get them configured into systems to fit your exact requirements.

Each CompuPro CPU board bridges the 8- and 16-bit worlds to give you the advantages of both — and the drawbacks of neither. And Viasyn supports them with a full range of other peripherals, from memory boards, controller boards, and interface boards, to motherboards, disk storage subsystems, even enclosures.

When you buy Viasyn's CompuPro CPU boards, you also have something else in store. Like a one- or two-year warranty, backed by a nationwide Systems Center network of highly-trained, responsive service professionals.

So the next time you're searching for room and board, call us toll-free at Viasyn.

We're a nice place to visit, and you can't beat our rates.

**VIASYN**™  
the CompuPro People

**Where Computers Grow**

3506 Breakwater Court, Hayward, CA 94545 • 800/367-7816 • In CA, 415/786-0909

CompuPro is a registered trademark of Viasyn Corporation.



tion known as *value encoding*. On a sequential computer, a variable can have only one value at a time. A parallel computer, however, may need to simultaneously access many values of a variable. In value encoding, we represent the different possible values of a variable as discrete cells or "intervals." The number of cells used determines the accuracy in the representation.

For example, we can represent the parameters for the edge element of

figure 7b as discrete intervals centered at  $(x_i, y_i)$ , with a width of  $(\Delta x, \Delta y)$  (see figure 8a). We can also represent the line parameters of figure 7c as discrete intervals centered at  $(\rho_i, \theta_i)$ , with a width of  $(\Delta \rho, \Delta \theta)$  (see figure 8b). This idea was suggested by Horace Barlow at Cambridge and is being pursued by D. H. Ballard and Jerome Feldman at the University of Rochester. We can then hard-wire the accumulation (or voting) process from figure 7 directly into hardware. Thus,

in figure 8a we assign a distinct processor for all the values of  $(x, y)$  that fall within the boundaries  $(\Delta x, \Delta y)$  and a specified range of  $\theta$ . In figure 8b, we assign a distinct processor for all the values of  $(\rho, \theta)$  that fall within the boundaries  $(\Delta \rho, \Delta \theta)$ . Each processor can either be on or off, based on a modification of the algorithm we described earlier:

For each edge unit, turn it on if its input exceeds some threshold. For each line unit  $(\rho, \theta)$ , turn it on if its input exceeds some threshold. That is, if enough colinear edge units are "turned on" (figure 8a), the line that encompasses all of those edges will be turned on (see figure 8b); that is, the system will draw a line with those parameters.

This realization of the Hough transformation shows how complex wiring carrying simple excitation can replace the complex information flow of voting. Nets of fairly simple computing units with highly structured connections carrying simple excitatory and inhibitory levels can provide a uniform architecture for computation at many levels of abstraction, from early vision to symbolic and cognitive levels.

We have tried to highlight some of the various issues that arise in these kinds of parallel models. However, at this point the reader may still be wondering how applicable this kind of computation is to a general vision system. The first-order answer is that generality is achieved through hierarchies. The line computation can serve as a subnetwork in a much larger network that spans the vision abstraction hierarchy (see figure 1). Hierarchies may be a ubiquitous strategy for organizing information in animals. Figure 9 shows Kiel's ontological ("related to or based upon being or existence") hierarchy of children's preferences (see reference 11). Kiel's hierarchy is also evident in eye-movement experiments, during which adult subjects showed the same kind of attentional preferences. Hierarchical organization may also be traceable to brain anatomy, although data is only

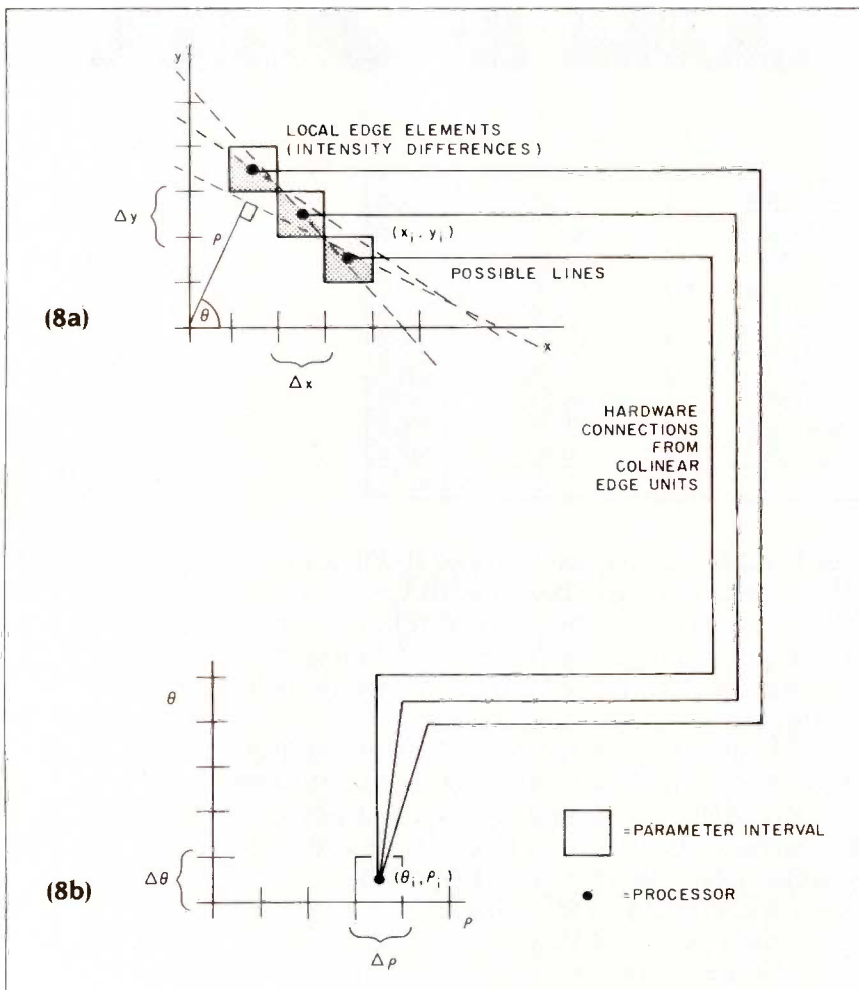

Figure 8: The "voting process" of figure 7 can be directly encoded in hardware using interval encodings. (a) For each of a discrete number of  $(x, y)$  values with bounds  $(\Delta x, \Delta y)$ , we assign a specific processor. (b) For each of a discrete number of  $(\rho, \theta)$  values with bounds  $(\Delta \rho, \Delta \theta)$ , we assign a specific processor. If enough colinear edge units are "turned on," the line that encompasses all of those edges will be turned on. This strategy may be impractical for VLSI (very-large-scale integration) designs, but it is realizable in the brain, which has approximately  $10^{10}$  neurons and approximately  $10^4$  connections per neuron.

available for the visual areas (see reference 12). Hierarchies may be a global organization feature of the cortex.

## CONCLUSION

The most important breakthrough in computer vision in the past decade has been a broad understanding of what has to be computed and how the computations are organized. Current research is shaped by the discovery that vision primitives (intermediate images) form a natural hierarchy and that the amount of computation required to build this hierarchy is enormous. Now that we have an understanding of what to compute, the crucial issue is that of computing it in real time. Throughout the decade, there has been a close relationship between "pure" vision research, which ignores biological constraints, and that which directly attempts to explain how the animal vision system works. The underlying intent of this article has been to show that ideas connected with animal vision, contrary to many earlier expectations, are playing an increasingly compelling role in shaping computer-vision research. The current notion of hierarchy of representations was developed without direct connections to animal research, but concurrent research shows that animal brains already incorporate hierarchical representations as a fundamental design principle. Furthermore, it seems likely that the biological system has also solved the parallel-computation problem that is emerging as the issue for formal vision studies. Thus we can anticipate a profusion of cross-disciplinary research efforts in the decade ahead, in the drive to realize practical, real-time visual perception. ■

## BIBLIOGRAPHY

Ballard, D. H., and C. M. Brown. *Computer Vision*. New York: Prentice-Hall, 1982.  
 Barrow, H. G., and J. M. Tenenbaum. *Proceedings, IEEE* 69, 1981, pages 572-595.  
 Brady, M. *Computing Surveys* 14, 1982, pages 3-72.  
 Hanson, A. R., and E. M. Riseman, eds. *Computer Vision Systems*. New York:

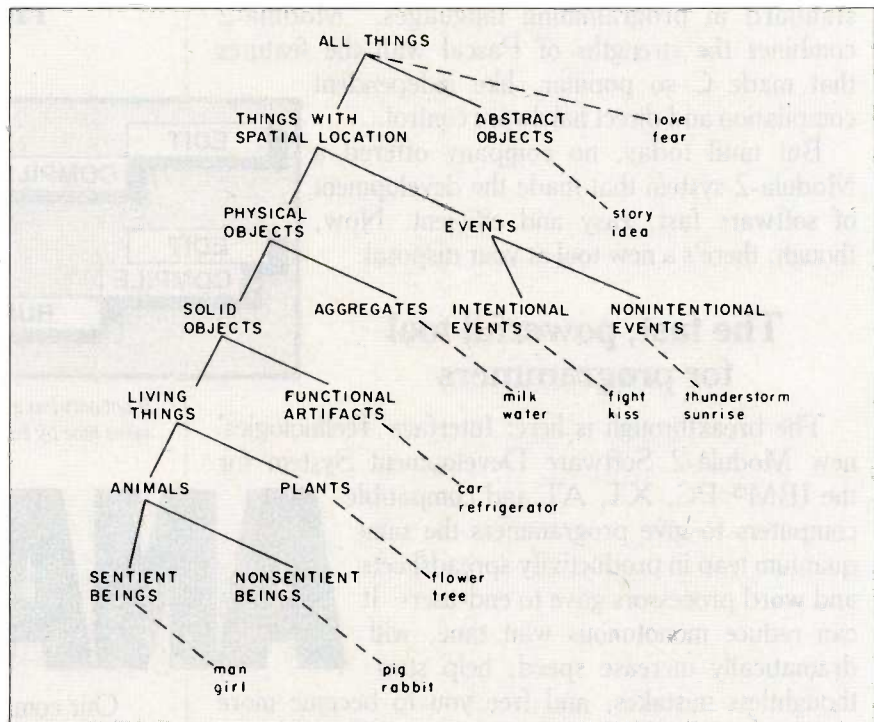

Figure 9: Kiel's ontological hierarchy established via testing of children.

Academic Press, 1977.  
 Marr, D. *Vision*. San Francisco: W.H. Freeman and Co., 1982.  
 Nevatia, R. *Machine Perception*. New York: Prentice-Hall, 1982.

## REFERENCES

1. Roberts, L. G., in J. P. Tippett et al., eds. *Optical and Electro-Optical Interaction Processing*. Cambridge, MA: MIT Press, 1965.
2. Treisman, A. M. "The Role of Attention in Object Perception." In O. J. Braddick and A. C. Sleigh, *Physical and Biological Processing of Images*. Berlin: Springer-Verlag, 1983.
3. Crick, F. "The Function of the Thalamic Reticular Complex: The Searchlight Hypothesis." submitted to *Proceedings of the National Academy of Sciences*, 1984.
4. Mishkin, M., L. G. Ungerleider, and K. A. Macko. "Object Vision and Spatial Vision: Two Cortical Pathways." *Trends in NeuroSciences*, October 1983.
5. Duda, R. O., and P. E. Hart. "The Use of the Hough Transform to Detect Lines and Curves in Pictures." *Communications of the ACM* #15, vol. 1, January 1972, pages 11-15.
6. Ballard, D. H. "Parameter Networks: Towards a Theory of Low-Level Vision." *Proceedings, 7th IJCAI*, Vancouver, BC., August 1981; also appeared as "Parameter Net-

works." *Artificial Intelligence* 22, 1984, pages 235-267.

7. Kirkpatrick, S., C. D. Gelatt, and M. P. Vecchi. "Optimization by Simulated Annealing." *Science* 220, 1983, pages 671-680.
8. Hopfield, J. J. "Neural Networks and Physical Systems with Emergent Collective Computational Abilities." *Proceedings of the National Academy of Sciences USA* 79, 1982, pages 2554-2558.
9. Hinton, G. E., and T. J. Sejnowski. "Optimal Perceptual Inference." *Proceedings, IEEE Computer Vision and Pattern Recognition Conference*, Washington, DC, June 1983, pages 448-453.
10. Geman, S., and D. Geman. "Stochastic Relaxation, Gibbs Distributions, and the Bayesian Restoration of Images." TR, Brown University, September 1983.
11. Kiel, F. C. *Semantic and Conceptual Development: An Ontological Perspective*. Cambridge, MA: Harvard University Press, 1979.
12. Van Essen, D. C., and J. H. R. Maunsell. "Hierarchical Organization and Functional Streams in the Visual Cortex." *Trends in NeuroSciences*, September 1983.

## ACKNOWLEDGMENTS

Preparation of this paper was supported by the Defense Advanced Research Projects Agency under Grant N00014-82-K-0193 and NSF Grant MCS-8203028.



## INTRODUCING Interface Technologies' Modula-2 Software Development System

The computer press is hailing Modula-2 as "the next standard in programming languages." Modula-2 combines the strengths of Pascal with the features that made C so popular, like independent compilation and direct hardware control.

But until today, no company offered a Modula-2 system that made the development of software fast, easy and efficient. Now, though, there's a new tool at your disposal.

### The fast, powerful tool for programmers

The breakthrough is here: Interface Technologies' new Modula-2 Software Development System for the IBM® PC, XT, AT and compatible computers to give programmers the same quantum leap in productivity spreadsheets and word processors gave to end-users. It can reduce monotonous wait time, will dramatically increase speed, help stop thoughtless mistakes, and free you to become more creative in virtually all of your programming efforts.

### How to speed input and eliminate 30% of errors

Thirty percent of programming mistakes are syntax errors and simple typos in the program structure. Our "syntax-directed" Modula-2 editor does away with these time-consuming headaches once and for all.



Enter complete statements  
with one keystroke.

It speeds input by cutting manual typing as much as 90%, letting you enter statements with a single keystroke. For example, if you type a capital "I" to begin a line, the editor completes the logical "IF THEN" statement automatically, so you can concentrate on what you want to program, rather than concentrate on what you're typing.

The editor locks out errors, finishing statements and procedures in perfect accord with the standardized rules of Modula-2. It also indents and formats your text automatically, making programs easy to read and maintain, an important feature on big projects.

And if you leave an undefined variable or data type, the editor detects the mistake and gives you the option of on-line "help" to correct it. No other programming text editor offers you so much innovation at any price.

### How to turn "wait time" into "work time"

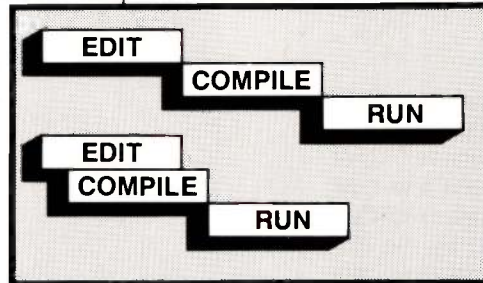

It not only has a faster compiler, it also saves time by compiling while you edit.

The vast majority of programming time is spent waiting, and the biggest slowdown is most often with compilers.

# THE ANATOMY OF A

Our compiler turns wait time to work time with a new innovation that lets you compile in the "background."

With background compilation, your program is automatically compiled into object code line by line as you work, every minute you spend writing or editing a Modula-2 program!

When you're finished editing, all that's left for the compiler is a quick mopping up job that generates optimized native code in a single pass.

### How quick is "quick"?

Thanks to background compilation and the fact that the compiler itself is so fast, Interface Technologies' compiler turns 100 lines of typical Modula-2 text into optimized machine code in *under five seconds*.

Plus the Interface compiler produces compact code with execution speed superior to that produced by any other Modula-2 compiler on the market.

### How to do two things at once

Along with the background compiler and syntax-directed editor, which can save you hours every day and make you more productive, Interface Technologies' Software Development System gives your monitor

windows so you can refer to one file while you edit another simultaneously, saving you even more time.

Concurrent editing of two or more files is especially useful when doing programming work that's intended for separate compilation, and Interface Technologies has the only Modula-2 system on the market that provides you with this helpful benefit for developing software.



*Work with multiple files faster, easier in windows.*

## How preprogrammed modules speed development

One of the advantages of Modula-2 is that it lets you build large, reliable programs quickly, by linking together many smaller "building-block" modules.

The development system's toolkit of precompiled program modules includes the standard Modula-2 library, and adds exclusive link-and-run modules for direct calls to the operating system, sound, and color

You can use it on any IBM® PC, XT, AT or compatible computer with two double-sided, double-density floppy drives and 320K RAM diskette.

You get a thoroughly indexed, comprehensive user's manual and free telephone support from Interface Technologies. But the most important thing you get is the future, and *the programming language of the future is Modula-2*, and now it's easier than ever.

For more information, or to order the Modula-2 Software Development System, call 1-800-922-9049 today. In Texas, call (713) 523-8422.

You can also order or request further information by mail. Just fill out the coupon below and send it in. Act today and receive your system soon.

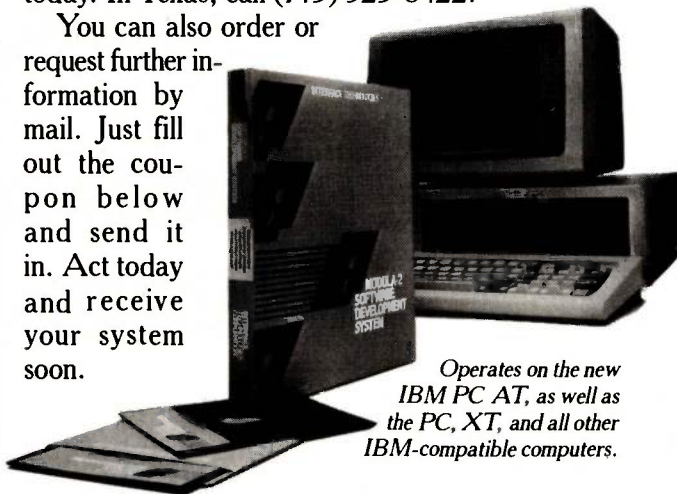

*Operates on the new IBM PC AT, as well as the PC, XT, and all other IBM-compatible computers.*

# BREAKTHROUGH

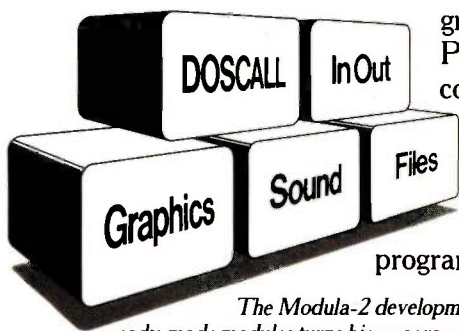

graphics support. Plus you get low-cost updates from the Interface Technologies fast-growing library of new programming modules.

*The Modula-2 development system's toolkit of ready-made modules turns big programs into smaller projects.*

## Increase productivity for \$249

Interface Technologies' Software Development System is fast, powerful and unlimited. It works so well that it's the same tool Interface Technologies is using to write business and consumer applications in Modula-2.

For \$249, you get the syntax-directed editor and compiler, linker, module library and tutorial that will have even modestly experienced programmers writing in Modula-2 in days. And you have full rights to your work; there's no license fee for programs you develop with the Interface Technologies system.

NAME \_\_\_\_\_  
 ADDRESS \_\_\_\_\_  
 CITY \_\_\_\_\_ STATE \_\_\_\_\_ ZIP \_\_\_\_\_  
 PHONE \_\_\_\_\_  
 PLEASE CHECK ONE:  
 AMERICAN EXPRESS     VISA     MASTERCARD  
 CHECK ENCLOSED  
 CHARGE ACCOUNT NUMBER  
 \_\_\_\_\_  
 EXPIRATION DATE \_\_\_\_\_ SIGNATURE \_\_\_\_\_  
 PLEASE SEND ME \_\_\_\_\_ COPIES @ \$249 EACH.  
 INTERFACE TECHNOLOGIES CORPORATION  
 3336 RICHMOND, SUITE 200, HOUSTON, TX 77098  
 Texas residents, add 6.125% Sales Tax. BT-4

IBM is a registered trademark of International Business Machines Corporation.

**INTERFACE TECHNOLOGIES**



**MODULA-2 SOFTWARE DEVELOPMENT SYSTEM**



# We Set the Standard in Prices!

For IBM PC Add-On Products.

Superior quality products and services at lowest prices.

Look at what we have to offer, before you buy any add-on products for your IBM PC.



**QIC-01.** 10 MB internal hard disk subsystem at ~~\$725~~ - *too low to quote!*

Our half-height 10 MB hard disk comes complete with controller, cables, Microscience drive and easy to follow instructions. It fits inside one of your floppy slots and draws same amount of current as a floppy. It is compatible with DOS 2.0, 2.1 and 3.0 without any patches. In fact, you can simply boot up from the hard disk. This is the same hard disk system you see advertised for hundreds of dollars more.

20 MB half-height internal hard disk **CALL.**  
20 MB drive for PC AT **\$895.**  
40 MB full height with controller **\$1495.**

**QIC-02 FT.** 10 MB Floppy tape back-up drive. **\$575.**

This half-height drive connects to your IBM floppy controller card. If your PC is running out of slot, this is a perfect solution. It backs up 10 MB in 5 minutes.  
20-60 MB Cartridge tape subsystem **\$995.**

**QIC-03.** 300/1200 baud internal modem. **\$275.**

This auto dial/auto answer plug-in modem lets your PC talk to the world with reliable and easy operation. It is FCC certified, Bell 103/212 compatible as well as fully Hayes compatible. You can run all the popular communication programs as well as our superior QIC Com software program.

Our QIC-Com software program provides phone list management as well as powerful file transfer capabilities. You can even run any DOS programs such as WordStar concurrently without having to disconnect your line. Priced at \$45.00, it is an offer you don't want to miss.

**QIC-04.** Half-height floppy drive. **\$129.**

This half-height floppy is the quietest drive on the market. It draws the least amount of current and is compatible with your PC's floppy controller card. It's double sided, double density.

**QIC-05.** Five function card. **\$199.** (64 K RAM Set \$33.00).

Our five function card includes memory expansion from 0 to 384K, one serial port, one parallel port, one game port and one battery back-up clock calendar. RAM disk, print spooler and clock utilities are also included.

Expansion box with 10 MB hard disk **\$1495.**  
Expansion box with 20 MB hard disk **\$1995.**

#### One Year Guarantee

No Risk. All our products are guaranteed for one year. And remember, if for any reason, you are not completely satisfied within 30 days, you can return it for a full refund. Check out our competition and find out which is best. We know better.

CALL US TODAY AT  
**408-942-8086**

**QIC RESEARCH**  
INCORPORATED  
489 Valley Way  
Milpitas, CA 95035

# LEARNING IN PARALLEL NETWORKS

BY GEOFFREY E. HINTON

## *Simulating learning in a probabilistic system*

THE BRAIN is an incredibly powerful computer. The cortex alone contains over  $10^{10}$  neurons, each connected to thousands of others. All of your knowledge is probably stored in the strengths of these connections, which somehow give you the effortless ability to understand English, to make sensible plans, to recall relevant facts from fragmentary cues, and to interpret the patterns of light and dark on the back of your eyeballs as real three-dimensional scenes. By comparison, modern computers do these things very slowly, if at all. They appear very smart when multiplying long numbers or storing millions of arbitrary facts, but they are remarkably bad at doing what any five-year-old can.

One possible explanation is that we don't program computers suitably. We are just so ignorant about what it takes to understand English or interpret visual images that we don't know the appropriate data structures and procedures to put into the machine. This is what most people who study artificial intelligence (AI) believe, and over the last 20 years they have made

a great deal of progress in reducing our ignorance in these areas.

Another possible explanation is that brains and computers work differently. Perhaps brains have evolved to be very good at a particular style of computation that is necessary in everyday life but hard to program on a conventional computer. Perhaps the fact that brains store knowledge as connection strengths makes them particularly adept at weighing many conflicting and cooperating considerations very rapidly to arrive at a common-sense judgment or interpretation. Of course, any style of computation whatsoever can be *simulated* by a digital computer, but when one kind of machine simulates a very different kind it can be very slow. To simulate all the neurons in a human brain in real time would take thousands of large computers. To simulate all the arithmetic operations occurring in a Cray would take billions of people.

It is easy to speculate that the brain uses quite different computational principles, but it is hard to discover what those principles are. Empirical studies of the behavior of single

neurons and their patterns of connectivity have revealed many interesting facts, but the underlying computational principles are still unclear. We don't know, for example, how the brain represents complex ideas, how it searches for good matches between stored models of objects and the incoming sensory data, or how it learns. In this issue, Jerome A. Feldman describes some current ideas about how parallel networks could recognize objects (see "Connections" on page 277). I will describe one old and one new theory of how learning could occur in these brain-like networks. Please remember that these theories are extreme idealizations; the real brain is much more complicated.

### **ASSOCIATING INPUTS WITH OUTPUTS**

Imagine a black box that has a set of input terminals and a set of output

*(continued)*

Geoffrey E. Hinton is an assistant professor of computer science at Carnegie-Mellon University. He can be reached at the Computer Science Department, Carnegie-Mellon University, Pittsburgh, PA 15213.



# RUN/C:<sup>TM</sup> The C Interpreter

Available NOW for  
only \$149.95!



Finally, a painless introduction to the C language. With **RUN/C: The C Interpreter** you can create and run C language programs in an environment as easy to use as BASIC.

**RUN/C** is C for the rest of us. It is a robust implementation of standard K&R. **RUN/C** is for both the beginner and professional.

#### **FOR BEGINNERS . . .**

**RUN/C** provides a BASIC-like user interface for C, making **RUN/C** the easiest bridge to proficiency in this state-of-the-art language. This is an opportunity to learn a professional language using the immediate, interactive programming environment that has made BASIC the world's most widely used computer language.

#### **FOR PROFESSIONALS . . .**

If you are a professional programmer, **RUN/C** is ideal for creating simple programs, such as filters, for developing and debugging functions, and for writing and testing programs of real complexity and sophistication.

**RUN/C** includes full floating point, 8087 support, **structures, unions, initializers**, casts and more than 100 built-in C functions.

With **RUN/C** you get all this with a command structure modeled after BASIC's using familiar terms such as EDIT, RUN, LIST, LOAD, SAVE, TRON, SYSTEM, etc.

Since **RUN/C** is a true interpreter it means that C programs can be written, tested and run within a single protected environment. It is a teaching tool and a source code debugger.

#### **Here's more good news . . .**

- Great documentation: a 475-page, easy-to-read manual filled with executable programs
- Array-index and pointer bounds checking
- Variable-trace and dump diagnostics PLUS an integral program profiler
- Full buffered and unbuffered file I/O
- Printer and asynch support
- Forking to your favorite full

screen editor with automatic return to **RUN/C** with your edited program

- System Requirements: IBM® PC or compatible with PC-DOS 2.0 or MS<sup>TM</sup>-DOS 2.0 or greater with ANSI.SYS.
- Nearly 100 sample C programs on disk

Get things right the first time with **RUN/C:**  
**The C Interpreter.<sup>TM</sup>**

For immediate delivery or more information:

Call  
**1-800-847-7078**  
In NY, **1-212-860-0300**

**Lifeboat<sup>TM</sup> Associates 1651 Third Ave. New York, NY 10128**

RUN/C is a trademark of Age of Reason Co.



## PARALLEL NETWORKS

*Ideally, the black box will capture some neat regularity in its connection strengths.*

terminals. Each terminal can be clamped into either of two states, active or inactive (1 or 0). We can show the black box what we would like it to do by repeatedly clamping a combination of 1s and 0s on the input terminals and another combination of 1s and 0s on the output terminals (each combination is called a *vector*). When we have done this for many I/O (input/output) pairs, we would like the black box to automatically set its output terminals into the correct state when we clamp a vector on the input terminals. Ideally, if there is some neat regularity in the mapping from input vectors to output vectors, we would like the black box to "capture" this regularity in its internal connection strengths in order to give the "correct" output vector for input vectors it has never seen before. This kind of black box would be a very useful module to have within an intelligent system.

If the black box contains only direct connections from input terminals to output terminals, there is a beautifully simple learning procedure that adjusts the weights on these connections until every input vector causes the appropriate output vector. The learning procedure has two phases that keep alternating. In phase 1, we clamp an input vector on the input terminals and an output vector on the output terminals. Then we increment by a small amount,  $\delta$ , the weights of all connections that have both their input and output terminals active. In phase 2, we clamp the same input vector, but we let the black box decide for itself what output vector to produce, using the rule that an output terminal turns on if the sum of the weights on its connections from active input terminals is positive. We then



decrement by  $\delta$  all the connections that have both their input and output terminals active. If the network produces exactly the right output, these decrements will exactly undo all the increments we made in phase 1, because exactly the same pairs of input and output terminals will be active in the two phases. If, however, the network produces the wrong output in phase 2, some of the weights that were incremented will not be decremented or vice versa, so some weights will change.

The learning procedure I have described is a version of the Widrow-Hoff or "perception convergence" procedure. It has a remarkable property: If we keep cycling through all the pairs of input and output vectors using this two-phase procedure for each pair, we will converge on a set of weights that causes the right output vector for every input vector *if any such set of weights exists*. The big disappointment (which led people in AI to abandon this kind of model) is that for most interesting problems there is *no* suitable set of weights. The relationship between the input and output vectors is just too complicated to be captured by a system that has direct connections between input and output terminals. At the very least, there must be intermediate layers within the black box, and units in these layers must learn to extract a hierarchy of "features" of the input vector that can eventually cause the right output.

Here is an example of a relatively simple task that requires intermediate units. The input consists of two 8-bit vectors, one of which is a shifted version of the other. Only shifts one place to the left or one place to the right are allowed. There are two output terminals, one for each possible shift, and the black box must turn on the correct output terminal for any appropriately related pair of input vectors. The task sounds easy until you consider that any one of the input bits, considered in isolation, provides *no* information about what the output should be. Moreover, simply adding up evidence from all the separate in-

(continued)



Se habla Español

Call for programs not listed

Technical & Other Information (602) 246-2222  
TOLL-FREE ORDER LINE 1-(800) 421-3135

Call for pricing on other Sperry Computers.	<b>SPERRY PC COMPUTERS</b>	Authorized Sperry Dealer. Dealer Inquiries Invited.
Mono Desktop 256K, 2 Drives, Serial Port, Par. Port, Clock,		
MSDOS 2.11, GWBasic plus Other Software		\$1695
Portable Computer 256K, 2 Drives Full IBM Compatibility		\$1695

**DATA BASE MANAGEMENT SYSTEMS**

Fox and Geller Quickcode	\$125
Knowledgeman	\$249
Condor III	\$289
NWA Statpak	\$265
Tim IV	\$245
DBase Manager II	\$165
FRIDAY	\$159
Personal Pearl	\$215
PFS File	\$79
Electric Desk	\$195
RBase 4000	\$245
CLOUT 2	\$129
Power Base	\$219

**WORD PROCESSING**

Wordstar, Pro Pack	\$240
Samna III	\$310
Wordstar 2000 for IBM PC	\$238
Wordstar 2000 +	\$285
Leading Edge Word Processor/Merge	\$85
Microsoft Word With Mouse	\$279
Word Perfect	\$219
Volkswriter for the IBM PC	\$110
Volkswriter DeLuxe	\$149
Random House Spell Checker	\$36
PFS Write	\$78
Multimate	\$255
Peachtext 5000	\$185

**SPREADSHEETS**

Supercalc II	\$145
Supercalc III	\$160
Microsoft Multiplan	\$119
!TK Solver	\$259
Lotus 123	\$294
Symphony	\$415

**ACCOUNTING**

**TCS. Big Four equivalent of Peachtree Series 4 - Specially augmented and customized for your IBM PC Terminal and Printer - GL, AR, PA, AP, CP/M-80, CP/M-86 for PC XT, DOS 1.1, 2.0.**  
Each Module . . . \$65 For All Four \$249

CYMA	Call
Dollars & Sense	\$95
MBSI Accounting (Real World)	\$350
Tobias Managing Your Money	\$99

**TRANSFER PROGRAMS**

Hayes Smartcom	\$85
Move-it	\$79
Microstuff Crosstalk	\$95

**BEST PRICE IN U.S. FOR IBM PC OR CLONES**  
Multifunction Board - Includes Async Adapter, Parallel Adapter, Clock with battery back-up and Software, 64K memory expandable to 384K. 1 year warranty . . . \$235

**LANGUAGES**

Lifeboat Lattice C Compiler	\$265
Microsoft C Compiler	\$299
Microsoft Pascal Compiler	\$180
Microsoft Basic Compiler	\$235
Microsoft Basic Language	\$225

**FOR PC DOS**

PC Paint Brush	\$85
Norton Utilities	\$59
Copy II PC	\$24
Prokey V3.0	\$79
Harvard Project Manager+	\$275
Microsoft Flight Simulator	\$32

**HARDWARE**

ABC Printer Switch	\$85
Micro Fazer Parallel 64K	\$185
Hayes 1200 Modem	\$429
Hayes 1200b Modem for IBM PC	\$379
64K RAM Chips (9) 150 NSEC	\$24
Anchor Signalman 1200 baud Modem	\$245
IOmega Bernoulli 20 Megabyte	\$2595
Princeton RGB Monitor	\$459
Taxan RGB Vision 425	\$399

**Diskette Super Special!**  
10 D/S D/D (Qty 100) . . . \$13.95

**COMPUTERS**

IBM Computer . . . . . Call

**BOARDS FOR THE IBM PC OR LOOKALIKES**

Hercules Color Board with Par. Port	\$169
AST Six Pack	\$245
384K Board with 256K	\$275
Quadcolor I	\$185
STB Graphics II Board	\$335
Paradise Graphics Board	\$275
New Quadram Multifunction Board	Call

**PRINTERS**

**FREE! PRINTER SET SOFTWARE**  
Purchase an Okidata, Epson or Gemini printer and receive at no charge a menu driven program to set print characteristics or to make your computer function as a correcting typewriter. Retail value \$35. Available for most disk formats.

Gemini SG/10	Call
Gemini SG/15	Call
Okidata 82A, 83A, 93P	Call
Okidata 93P	\$569
Okidata 84P	\$650
Juki 6100	\$389
Juki 6300	\$689
Call on all Epson Models	
Silver-Reed EXP 400	\$235
Silver-Reed EXP 550	\$395
Toshiba 1351	\$1210
NEC, Diablo,	Call

TERMS: Prices include 3% cash discount. Add 3% for charge orders. Shipping on most items \$5.00. AZ orders +6% Sales Tax. Personal check, allow ten (10) days to clear. Prices subject to change.

TOLL-FREE ORDER LINE 1-(800)-421-3135

**WAREHOUSE DATA PRODUCTS**

2701 West Glendale Ave., Suite 6  
Phoenix, AZ 85021





put bits is useless. The task can be done only if you consider combinations of bits in one vector with bits in the other, which requires intermediate units that extract informative combinations. Figures 1a and 1b show a collection of useful intermediate feature detectors that work well together for performing this task.

When we try to extend the simple learning procedure to networks containing intermediate units, more complications arise because we do not know in advance how we want the intermediate units to behave. So instead of just fixing some weights that will make the output terminals behave in the way that we specify, the learning algorithm must also decide under

what circumstances each of the intermediate units should be active. This amounts to *creating* intermediate representations. Several more recent learning procedures can do this. I shall describe one that Terry Sejnowski and I discovered. It is only guaranteed to work in networks of a rather special kind, which I will now describe.

### NETWORKS THAT MINIMIZE THEIR ENERGY

The kind of network we have been considering so far consists of layers of units in which units in one layer are connected to units only in contiguous layers. More complex networks have cross-talk within a layer and feedback

from later layers to earlier ones. It is generally very hard to analyze the behavior of such networks, but John Hopfield at Cal Tech (reference 1) has shown that there is an interesting special case that behaves in a very useful way. In a Hopfield net, the units make their decisions asynchronously, the communication between units is instantaneous, and all the connections are symmetrical; the effect of unit *i* on unit *j* is the same as the effect of unit *j* on unit *i*. Given these restrictions, the various possible states of the whole network form a space like a bumpy surface and the current state of the network behaves like a ball bearing placed on this surface—it moves downhill into the nearest *local minimum*. Each point in the surface corresponds to a pattern of active and inactive units in the network, and the height of the surface at that point represents the "energy" of that pattern of activity, where the energy of a pattern is defined as minus the sum of all the weights on connections between pairs of active units. Therefore, if two units have a big positive weight between them, patterns in which they are both active will have low energy; it is patterns like this into which the network will settle. Conversely, a negative weight between two units will make a big positive contribution to the energy when they are both on, so the network will tend to avoid such states.

Figure 2 shows a small network whose lowest energy state is -8. Can you figure out which units are on and which are off in this state? You will always end up at an energy minimum if you start with a random state and then apply the following rule to each unit in turn (in any order): If the sum of the weights on the connections to other currently active units is positive, turn it on; otherwise, turn it off. If you apply this procedure a few times, you will discover that there is another minimum with an energy of -3 and that once the network has settled into this state it will just stay there.

Networks of this type can be used to associate input vectors with output vectors. To provide the input, we clamp a subset of the units into their

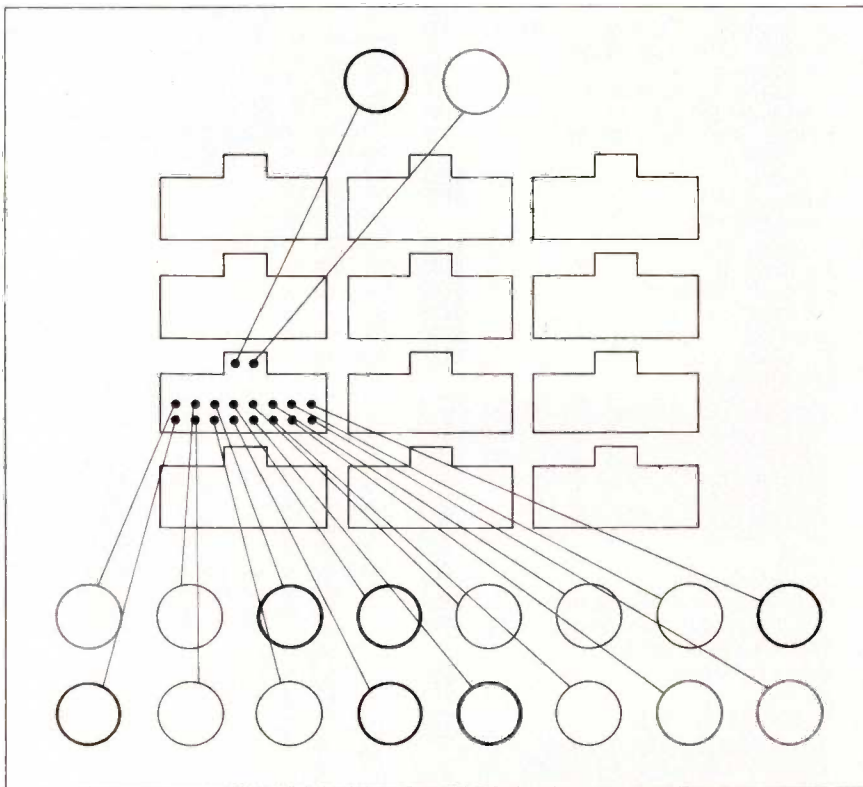

Figure 1a: A network with 16 input terminals, 12 intermediate units, and 2 output terminals. The boldface units show which bits are on in a typical pair of input and output vectors. The 8-bit vector at the bottom has been shifted one place to the left (with wraparound) to produce the 8-bit vector immediately above it. With these two vectors as the input, the correct output vector (shown at the top of the figure) has the left unit active to represent a left shift. Each of the 12 intermediate units is connected to all the input and output units, but only one set of connections is shown. The intermediate units also have a fixed threshold, which is subtracted from their net input before the decision is made to turn them on or off.

on or off states, and, once the rest of the network has settled into an energy minimum with this input vector clamped, we treat the states of another subset of the units as the output. In figure 2, for example, we could clamp the three bottom units into the active state to represent the input vector (1, 1, 1); we would get the output vector (1, 0) by letting the network settle and then reading the states of the top two units.

To teach the network a particular set of I/O pairs, we would need to create an appropriate energy landscape—we would need to choose weights so that for each clamped input vector the system had an energy minimum that yielded the correct output vector. Choosing such weights is not an easy task, and to make matters worse, we might end up with an energy landscape in which there were many different local minima for each clamped input; each input vector might give many different outputs depending on the energy minimum into which the system happened to settle. In figure 2, for example, the input vector (0, 0, 0) can generate two different output vectors depending on the initial states of the middle units and the order in which decisions get made.

**A PROBABILISTIC NETWORK**

If the same input is going to produce different outputs on different occasions, we would at least like to have some control over the probabilities. It would be nice, for example, if we could guarantee that deeper minima would be found more often than shallower ones. It would be even better if we could guarantee that the relative probability of ending up in two different minima depended *only* on their relative depths. We could then control the probabilities of getting particular outputs by manipulating the energy landscape (i.e., by changing the weights).

Once again, a physical analogy is helpful: If we have a ball bearing on a bumpy surface and we shake the whole system up and down, the ball bearing will be able to jump over the

(continued)

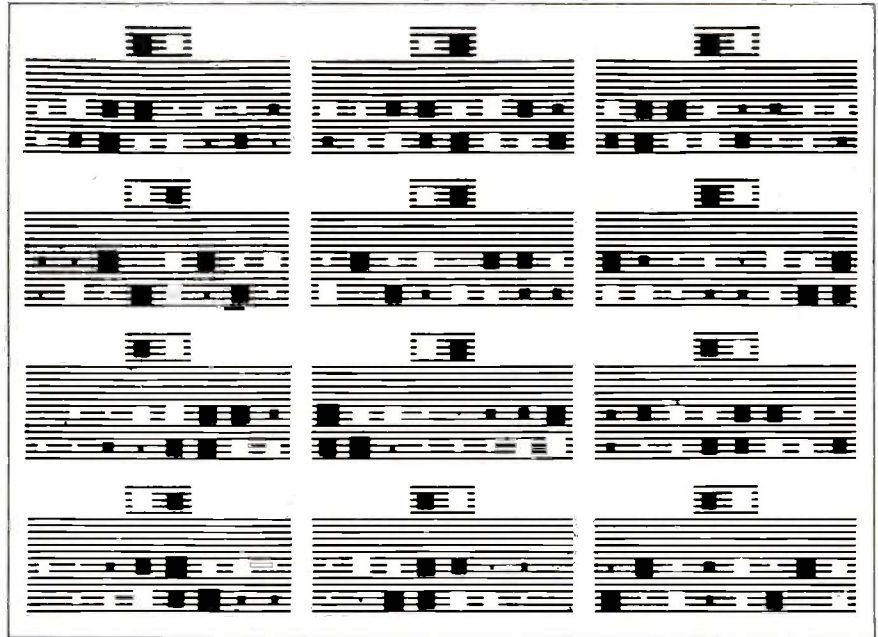

Figure 1b: The weights that are learned by the 12 intermediate units. The black and white rectangles in the bottom two rows of a unit represent the weights on its connections to the input terminals. The sizes of the rectangles indicate the magnitudes of the weights. Black indicates a negative weight. The two weights at the top of each unit show how it affects the two output terminals. The weights all start at 0 and change by very small steps. Notice that all 12 units detect different combinations of active input terminals and that these combinations are generally sensible predictors of the global shift for which the unit "votes."

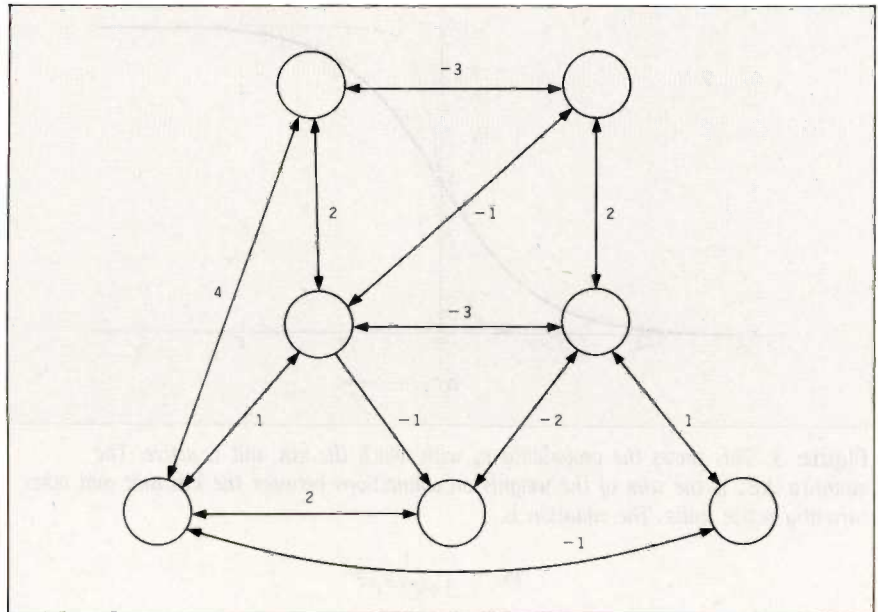

Figure 2: A simple network with three input units at the bottom, two intermediate units in the middle, and two output units at the top. All the connections are symmetrical.



barriers that separate shallow minima from deep ones; the ball bearing will spend most of its time in the deeper minima, even though it will occasionally sample higher energy states. If we shake for a while in just the right way, a useful simplification occurs: We approach a condition called "thermal equilibrium" in which the ball bearing is still moving from place to place, but the probability of finding it at any one place on the surface is stable and depends only on the height of the surface at that point—it doesn't depend on where the ball bearing started or on the shape of the energy landscape. More precisely, the log of the probability ratio of finding the ball bearing in two different states is proportional to the energy difference of those two states. Scott Kirkpatrick at IBM introduced the idea of using "thermal noise" to escape from local minima and to increase the chances of finding the deeper minima (see reference 2). He has shown that for large problems in which the cost of a solution is the analog of energy, an effective method for finding low-cost solutions is to start with a lot of thermal

noise and gradually reduce it—a process that he calls "simulated annealing."

In our parallel networks it is easy to introduce the analog of thermal noise. We just modify the decision rule that is used by the individual units. They still compute the sum of the weights on the connections coming from other active units, but instead of always turning on when this sum is positive and off when it is negative (which always reduces the energy of the network), they behave probabilistically, as shown in figure 3.

Using this probabilistic decision rule, we can run networks in the following way: Clamp an input vector, let the remaining units turn on and off probabilistically until the network has reached thermal equilibrium, and then read the output vector. At equilibrium the output units will continue to change states, but each output vector will have a fixed probability that does not vary with time.

Research teams in fields as diverse as statistics (Stuart and Donald Geman), neuroscience (Terry Sejnowski), psychology (Paul

Smolensky), and artificial intelligence are now investigating networks of this kind. Statisticians call them Markov Random Fields. At Carnegie-Mellon University we call our particular version the Boltzmann Machine, in honor of Ludwig Boltzmann, one of the founders of statistical mechanics.

### LEARNING AGAIN

We can now return to the issue of learning. First, we redefine the learning task in probabilistic terms. For each possible input vector, we want to produce each possible output vector with a certain probability. (Generally, most of these probabilities will be close to 0 and a few will be close to 1.) We can then train the network to behave in this way by alternating between two phases that are very similar to those used in the earlier learning rule.

In phase 1 we tell the network about the desired probabilities by clamping pairs of input vectors and output vectors with the corresponding frequencies. Each time a pair of input and output vectors is clamped, we run the network until it is close to thermal equilibrium; we then run the network for a little extra time, modifying the weights in the following way: For each unit of time during which two units are both active, we increment the weight between them by  $\delta$ .

In phase 2 we clamp input vectors and let the network decide for itself what output vector to give. Once it has approached equilibrium, we run a little longer, as before, and now *decrement* by  $\delta$  the weights between pairs of active units. If we keep alternating between phase 1 and phase 2, showing the network all the various pairs of input and output vectors, the net change in the weight between any two units will be proportional to the difference between the probability that the two units are both active in phase 1 and the probability that they are both active in phase 2 (averaged over all I/O pairs). It is remarkable that when these probabilities are measured at thermal equilibrium, their dif-

(continued)

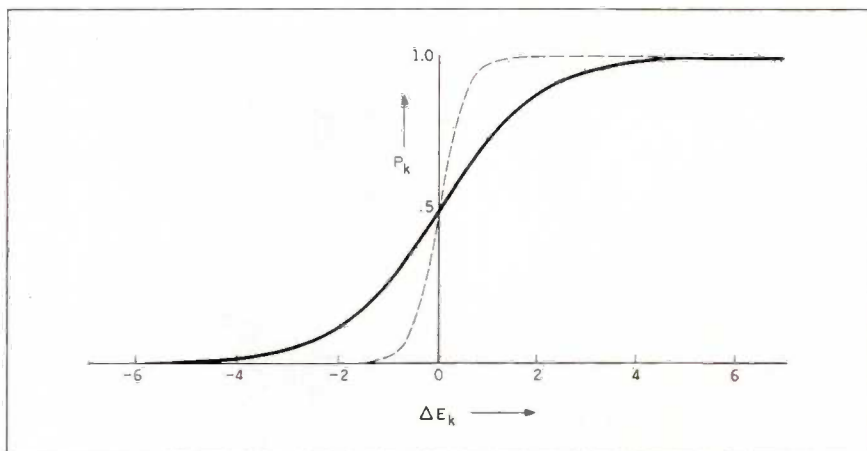

Figure 3: This shows the probability  $p_k$  with which the  $k$ th unit is active. The quantity  $\Delta E_k$  is the sum of the weights on connections between the  $k$ th unit and other currently active units. The equation is

$$p_k = \frac{1}{1 + e^{-\Delta E_k / T}}$$

$T$  is the level of thermal noise in the network. The solid curve is for  $T = 1$  and the dotted curve is for  $T = 0.25$ . If the value of  $T$  is decreased, the unit becomes less probabilistic. When  $T = 0$ , the curve becomes a deterministic step function.

# SoftCard II<sup>™</sup> squeezes the most juice out of your Apple.



Microsoft<sup>®</sup> SoftCard II is the latest high-performance CP/M<sup>®</sup> board that really juices the Apple<sup>®</sup> II, IIe and II+.

### Hard facts on SoftCard.

The new SoftCard has a high speed (6MHz) Z-80 that runs CP/M programs up to three times faster than lesser boards. Plus 64K memory. And if that wasn't enough, we also support the Apple Profile hard disk.

Microsoft BASIC is included so it's compatible with more Apple CP/M software than any other board on the market. Thousands of the juiciest business programs including dBaseII<sup>™</sup>, WordStar<sup>®</sup> and sophisticated Microsoft languages

like FORTRAN-80, COBOL-80 and BASIC Compiler.

Juicing up the performance of computers is nothing new for us. We invented the SoftCard and wrote Applesoft for the Apple II.

**MICROSOFT**<sup>®</sup>  
The High Performance Software<sup>®</sup> In fact, our BASIC is the language spoken by nine out of ten microcomputers worldwide.

Get the Apple juicer from Washington. Call (800) 426-9400. In Washington State, Alaska, Hawaii and Canada, call (206) 828-8088 and ask for the name of your nearest Microsoft dealer.

**MICRO  
SOFT**

Microsoft is a registered trademark and SoftCard and The High Performance Software are trademarks of Microsoft Corporation. Apple is a registered trademark of Apple Computer, Inc. dBase II is a trademark of Ashton-Tate. WordStar is a registered trademark of MicroPro. CP/M is a registered trademark of Digital Research, Inc.



# Speed ~~vs.~~ <sup>and</sup> Quality

Other daisy wheel printers still make you choose.

Diana Davis  
Operations Manager  
Development Company  
E. Graves Avenue  
New York, New York

Thank you for your inquiry on  
DaisyMax 830

At 80 characters per second, the DaisyMax 830 is one of the fastest letter-quality, daisy wheel printers you can buy.

And that means you no longer have to sacrifice image quality to increase productivity!

Speed and superb quality are but two of a long list of benefits you get with the DaisyMax 830.

Multiple users can share the DaisyMax 830 since it is designed for heavy volume word processing environments. Plus, you get standard

## DaisyMax 320™ & 830™



interfaces for easy installation, and friction, tractor and cut sheet feeders to handle all your office forms. All these great features also are available in the DaisyMax 320, offering print speeds up to 48 cps.

And of course *both* printers feature rugged reliability—a hallmark of Fujitsu products earned from over 30 years as a technology leader and equipment supplier to companies worldwide. Reliability backed by TRW service nationwide.

Contact your nearest distributor for your local dealer.

Inquiry 159

# Fujitsu Printers

Maximum Quality. Maximum Value.



# Authorized Fujitsu Distributors

**Algram Computer Products** (415) 969-4533, (714) 535-3630, (206) 453-1136, (916) 481-3466; **Allen Edwards Associates Inc.** (213) 328-9770; **Four Corners Technology** (602) 998-4440, (505) 345-5651; **Gentry Associates Inc.** (305) 859-7450, (305) 791-8405, (813) 886-0720, (404) 998-2828, (504) 367-3975, (205) 534-9771, (919) 227-3639, (803) 772-6786, (901) 683-8072, (615) 584-0281; **Inland Associates, Inc.** (913) 764-7977, (612) 343-3123, (314) 391-6901; **Logon Inc.** (201) 646-9222, (212) 594-8202, (516) 487-4949; **Lowry Computer Products, Inc.** (313) 229-7200, (216) 398-9200, (614) 451-7494, (513) 435-7684, (616) 363-9839, (412) 922-5110, (502) 561-5629; **MESA Technology Corp.** (215) 644-3100, (301) 948-4350, (804) 872-0994; **NACO Electronics Corp.** (315) 699-2651, (518) 899-6246, (716) 223-4490; **Peak Distributors, Inc.** (An affiliate of Dytec/Central) (312) 394-3380, (414) 784-9686, (317) 247-1316, (319) 363-9377; **R<sup>2</sup> Distributing, Inc.** (801) 595-0631; **R<sup>2</sup> Distributing of Colorado, Inc.** (303) 455-5360; **Robec Distributors** (215) 368-9300, (216) 757-0727, (703) 471-0995; **S&S Electronics** (617) 458-4100, (802) 658-0000, (203) 878-6800, (800) 243-2776; **The Computer Center** (907) 456-2281, (907) 561-2134, (907) 789-5411; **USDATA** (214) 680-9700, (512) 454-3579, (713) 681-0200, (918) 622-8740. **In Canada, Micos Computer Systems, Inc.** (416) 624-0320, (613) 230-4290, (514) 332-1930, (204) 943-3813; **SGV Marketing, Inc.** (416) 673-2323, (1-800) 387-3860 (outside Ontario); **Systemer Inc.** (514) 332-5581.

## Additional Ribbon Distributors

**Altel Data** (403) 259-7814; **EKM Associates, Inc.** (416) 497-0605; **Metropolitan Ribbon & Carbon** (703) 451-9072, (800) 368-4041; **The Very Last Word** (415) 552-0900, (800) 652-1532 CA, (800) 227-3993 USA. **In Canada, Tri-Media, Inc.** (514) 731-6815.

**Fujitsu Printers**  
Maximum Quality. Maximum Value.



## PARALLEL NETWORKS

ference is exactly the right quantity to use for changing the weights to make the behavior of the network in phase 2 (when it is deciding for itself) mimic the behavior in phase 1 (when it is being forced to behave in the desired way). To prove this it is necessary to define a measure of the difference between the probability distribution that is forced on the network in phase 1 and the probability distribution that it exhibits in phase 2. Once the correct measure has been defined, it can be shown that the measure is decreased by changing each weight according to the above procedure. The proof can be found in reference 3.

Figure 1 shows what the learning procedure can do when the task is to "recognize" the shift that was applied to one 8-bit vector to produce a second 8-bit vector. If you think this is an easy problem, remember that the network starts off with no preconceptions. It has no idea that neighboring input bits will have anything to do with each other, and it is not expecting this task any more than it is expecting any other. If the very same network is presented with a completely different combination of input and output vectors, it will create a different set of feature detectors that are appropriate for the different task.

### MAKING IT FASTER

The first learning algorithm I described just changes weights to make units behave in prespecified ways. It cannot figure out what to do with internal units whose required behavior is not specified from outside. The second learning algorithm is potentially much more powerful because it is able to decide how to use the internal units to help achieve the required I/O mapping. It actually constructs simple internal representations. Unfortunately, there is a heavy price to pay for this added power. The algorithm is currently extremely slow; the example in figure 1 requires hours of computer time.

To speed things up, Blake Ward, a graduate student at Carnegie-Mellon, has built a parallel machine containing six Omnibyte 68000 boards, each

of which has a copy of the entire network. Each board runs with a different input vector, and then all the boards agree on how to change the weights. This helps, but ultimately we would like to implement networks of these probabilistic units directly in silicon. Unlike current computers, these networks are rather tolerant of localized hardware failures or fabrication errors; Carver Mead has pointed out that an analog implementation of the processing elements would positively thrive on the kind of thermal noise that comes from running transistors at very low power. This might make it possible to build much larger chips than is currently feasible. However, developments like this are still a long way off, and they do not remove the need for more theoretical progress. Our current simulations are slow for three reasons: It is inefficient to simulate parallel networks with serial machines, it takes many decisions by each unit before a big network approaches equilibrium, and it takes an inordinate number of examples of I/O pairs before a network can figure out what to represent with its internal units. Better hardware might solve the first problem, but more theoretical progress is needed on the other two. Only then will we be able to apply this kind of learning network to more realistic problems. ■

### REFERENCES

1. Hopfield, John J. "Neural Networks and Physical Systems with Emergent Collection Computational Abilities," *Proceedings of the National Academy of Sciences*, 1982, vol. 79, pages 2554-2558.
2. Kirkpatrick, S., C. D. Gelatt, and M. D. Vecchi, "Optimization by Simulated Annealing," *Science*, 1983, vol. 220, pages 671-680.
3. Ackley, D. H., G. E. Hinton, and T. J. Sejnowski. "A Learning Algorithm for Boltzmann Machines," *Cognitive Science*, 1985, vol. 9, pages 147-169.

### ACKNOWLEDGMENTS

Terry Sejnowski and I performed the research described here while we were supported by grants from the System Development Foundation. I thank the members of the Boltzmann Group at Carnegie-Mellon for helpful comments.



# Last year the experts tested the top-of-the-line Toshiba 3-in-One™ printer.

## Here's what they said.

“When Toshiba America called to see if there were problems testing their printers, I responded, ‘You bet—I can’t get the P1351 off Bill Machrone’s desk long enough to get its picture taken!’ It’s that good.”

(Bill Machrone is the editor of PC Magazine.)

PC Magazine  
November 27, 1984

“It is setting new standards for quality and performance in the dot matrix arena.”

Computers & Electronics Magazine  
November 1984

“

”

# Imagine what they will say about its successor.



**The New Toshiba P351 3-in-One Printer.** They could say that inside the sleek new Toshiba P351 you'll find the ultimate 3-in-One printer. Because it offers a combination of:

Letter-quality printing. Perfectly translated graphics. And speed. (100 cps letter. And draft speed improved to 288 cps.)

They could say you'll appreciate the 24-pin dot matrix head that gives the P351 its exemplary letter and graphic quality.

They could say the new P351 gives you an almost unlimited number of ways to express yourself. With both downloadable software fonts and new plug-in font cartridges.

And they could say the new P351 is not only the best looking printer in the \$1,000 to \$2,000 range. But also the most reliable.

Of course, we're not putting words in their mouths. Just the ultimate 3-in-One printer in their hands. And yours.

For complete information call 1-800-457-7777, Operator 32.

In Touch with Tomorrow

## TOSHIBA

TOSHIBA AMERICA, INC., Information Systems Division



# THE 8087 AND 80287 ARE IN STOCK!

MicroWay is the world's leading retailer of 8087s and high performance PC upgrades. We stock a complete selection of 8087s that run at 5 and 8mhz. All of our coprocessors are shipped with a diagnostic disk and the best warranty in the business - 180 days! We also offer daughterboards for socketless computers such as the NEC PC and PCjr, and a board which increases the clock speed of the 80287 in the PC AT. Our new NUMBER SMASHER™ will run the IBM PC at clock speeds up to 9.5mhz and achieves a throughput of .1 megaflops with 87BASIC/INLINE,

Intel Fortran, or Microsoft Fortran. Software reviewers consistently cite MicroWay software as the best in the industry! Our customers frequently write to thank us for recommending the correct software and hardware to meet their specific needs. They also thank us for our same day shipping! In addition to our own products which support the 8087 and 80287, we stock the largest supply of specialized software available anywhere. These include three FORTRANs, three PASCALs, APL, Intel's ASM-86 and PL/M-86, several Cs, 87BASIC/INLINE,

87MACRO, 87FFT, and MATRIXPAK. For real time or multi-user applications we offer RTOS™ - our implementation of Intel's iRMX executive. Our new products include a professional debugger with 8087 support, support for Lotus 1-2-3, and a translator that converts object modules into readable assembly language files. If you have a question about which computer, language, compiler, operating system or application package is best suited to your problem, we can answer it. Just call:

**617-746-7341**

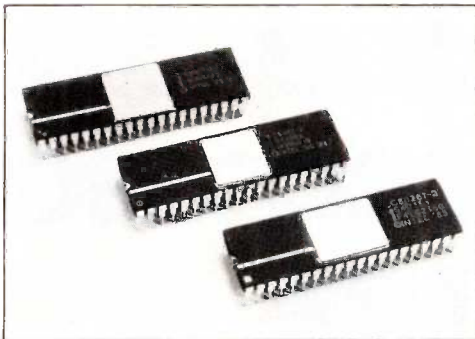

## MicroWay™ 8087 Support

For the IBM PC, PC XT, PC AT and Compatibles.

**87FFT™** performs Forward and Inverse FFTs on real and complex arrays which occupy up to 512K bytes of RAM. Also does convolutions, auto correlations, hamming, complex vector multiplication, and complex to radial conversions. Callable from MS Fortran or 87BASIC/INLINE. .... **\$150**

**87FFT-2™** performs two-dimensional FFTs. Ideal for image processing. Requires 87FFT. .... **\$75**

**MATRIXPAK™** manages a **MEGABYTE!** Written in assembly language, our runtime package accurately manipulates large matrices at very fast speeds. Includes matrix inversion and the solution of simultaneous linear equations. Callable from MS Fortran 3.2, 87MACRO, 87BASIC/INLINE, and RTOS. .... each **\$150**

### GRAPHICS PACKAGES

Energraphics (stand alone) ..... **295**  
Grafmatic for MS Fortran or Pascal ..... **125**  
Plotmatic for Grafmatic ..... **125**  
Halo for Basic, C or Fortran ..... each **150**

### OTHER TOOLS

Alpha Software ESP ..... **500**  
Borland Sidekick, Toolbox, or Graphics ..... **35**  
SuperKey ..... **70**  
COSMOS Revelation ..... **850**  
smARTWORK ..... **895**  
SPSS/PC ..... **695**

### DFixer

A disk utility which thoroughly checks PC or AT hard disks for bad sectors and updates the MS DOS file allocation table accordingly. .... **149**

### MAYNSTREAM

Maynard's portable streaming tape backup. 60 megabyte version ..... **1695**  
Cartridge ..... **50**

**87BASIC™** includes patches to the IBM Basic Compiler and both runtime libraries for USER TRANSPARENT and COMPLETE 8087 support. Provides super fast performance for all numeric operations including trigonometrics, transcendentals, addition, subtraction, multiplication, and division. .... **150**

**87BASIC/INLINE™** converts the output of the IBM Basic Compiler into optimized 8087 inline code which executes up to seven times faster than 87BASIC. Supports separately compiled inline subroutines which are located in their own segments and can contain up to 64K bytes of code. This allows programs greater than 128K! Requires the IBM Basic Compiler and Macro Assembler. Includes 87BASIC ..... **\$200**

**87MACRO™** - our complete 8087 software development package. It contains a "Pre-processor," source code for a set of 8087 macros, and an object library of numeric functions including transcendentals, trigonometrics, hyperbolics, encoding, decoding and conversions. For the IBM Macro Assembler, Version 1.0 or 2.0. .... **\$150**

**OBJ → ASM™** - a multipass object module translator and disassembler. Produces assembly language listings which include public symbols, external symbols, and labels commented with cross references. Ideal for understanding and patching object modules and libraries for which source is not available. .... **\$200**

**87DEBUG™** - a professional debugger with 8087 support, a sophisticated screen-oriented macro command processor, and trace features which include the ability to skip tracing through branches to calls and software and hardware interrupts. Breakpoints can be set in code or on guarded addresses in RAM. .... **\$150**

**RTOS - REAL TIME OPERATING SYSTEM**  
RTOS is a multi-user, multi-tasking real time operating system. It includes a configured version of Intel's iRMX-86, LINK-86, LOC-86, LIB-86, OH-86, and MicroWay's 87DEBUG. Runs on the IBM-PC, XT, PC-AT and COMPAQ. .... **400**

### INTEL COMPILERS<sup>1</sup>

FORTRAN-86 ..... **750**  
PASCAL-86 ..... **750**  
PL/M-86 ..... **500**  
87C (LATTICE/MICROWAY) ..... **750**  
ASM-86 ..... **200**

<sup>1</sup>Requires RTOS or iRMX-86. All Intel compiler names and iRMX-86 TM Intel Corp.

### HARDWARE AND LANGUAGES

**8087-3 5mhz** ..... **\$149**  
Including DIAGNOSTICS and 180-day warranty  
For IBM PC and compatibles.

**8087-2 8mhz** ..... **\$275**  
For Wang, AT&T, DeskPro, NEC, Leading Edge

**80287-3 5mhz** ..... **\$275**  
For the IBM PC AT

**64K RAM Set** ..... **\$20**

**256K RAM Set** ..... **\$125**

**128K RAM Set PC AT** ..... **\$175**

**NUMBER SMASHER™** ..... **1590**  
9.5mhz 8087 coprocessor board for the IBM PC

**LOTUS 1-2-3™ 8087 Support** ..... **CALL**

### FORTRAN and UTILITIES

Microsoft Fortran 3.2 ..... **229**  
IBM Professional Fortran ..... **545**  
Intel Fortran-86<sup>1</sup> ..... **750**  
FORLIB+ ..... **65**  
STRINGS and THINGS ..... **65**

### C and UTILITIES

Lattice C ..... **299**  
Microsoft C V 3.0 ..... **CALL**  
C86 ..... **299**  
C TOOLS ..... **85**  
C Trigs and Trans ..... **150**

### BASIC and UTILITIES

IBM Basic Compiler ..... **270**  
87BASIC/INLINE ..... **200**  
Summit BetterBASIC™ ..... **175**  
Summit 8087 Module ..... **87**

### MACRO ASSEMBLERS

IBM Assembler with Librarian ..... **155**  
87MACRO ..... **150**  
Microsoft Assembler V 3.0 ..... **125**

### PASCAL

Microsoft Pascal 3.2 ..... **199**  
Borland Turbo Pascal ..... **35**  
Turbo with 8087 Support ..... **85**

### APL

STSC APL★PLUS/PC ..... **475**  
Pocket APL ..... **85**

1-2-3 and Lotus are trademarks of Lotus Development Corporation.

CALL FOR COMPLETE CATALOG

**MicroWay**

P.O. Box 79  
Kingston, Mass.  
02364 USA  
(617) 746-7341

**You Can  
Talk To Us!**

## CONNECTIONS

BY JEROME A. FELDMAN

### *Massive parallelism in natural and artificial intelligence*

A FUNDAMENTAL PREMISE of artificial intelligence (AI) is that intelligent behavior can be simulated on digital computers. Great progress has been made in AI, with far-reaching practical and scientific consequences. Despite successes with quite specific problems, however, many researchers feel that the general questions of intelligence have barely been touched. The field of AI is nowhere near possessing the ability to simulate the natural intelligence of a small child or even a simple animal. Yet the basic computing speed of modern computers is about a million times faster than the firing rate of a neuron, which is in the millisecond range.

The situation becomes even more striking when we consider the speed of human responses on simple tasks. When asked to carry out a wide range of tasks, such as naming a picture or deciding if some sound is an English noun, people can respond correctly in about half a second. This means that the brain, a device composed of neural elements with a basic computing speed of a few milliseconds, can solve difficult problems of vision and language in a few hundred milliseconds (0.5 second = 500 millisec-

onds), or about 100 steps. The best AI programs for these tasks are not nearly as general and require millions of computational time steps. Of course, the brain is a parallel device, while essentially all of our existing machines are sequential, executing one instruction at a time. But what are the algorithms used in this massively parallel natural computer?

The exploration of possible algorithms for this radically different architecture forms the cornerstone of a promising new branch of artificial intelligence. Workers in the field use an abstract computer that is as similar as possible to the brain in structure and performance. This approach permits AI researchers to collaborate closely with colleagues in the brain and behavioral sciences; a good algorithm for some task on a computational model can also serve as a prototype theory for the mechanisms the brain uses on the same problem. Some psychologists have found that constructing massively parallel computational models to fit their data is far easier than constructing models based on sequential machines. The cycle is complete when AI researchers use experimental results to guide the con-

struction of parallel algorithms for various problems.

In addition to the 100-step restriction, using the brain as a model has other computational consequences. For one thing, the timing constraints limit to a few bits the information that can be sent from one neuron to another. This means that units cannot pass the large symbolic structures common in AI and that the computational richness must lie in the connections among units; this has led to the use of the term "connectionist" to characterize these models.

Using the brain as a model does allow for quite a lot of connections, up to about 10,000 per unit. The total number of neurons (about 100 billion) seems large but is actually a major limitation. Since vision has a million parallel inputs, any algorithm requiring  $n^2$  units would not fit. Also, the brain grows no new units and essen-

*(continued)*

*Jerome A. Feldman (University of Rochester, Rochester, NY 14627) is a professor of computer science and holds a doctorate from Carnegie-Mellon University. His research interests include programming languages and systems, AI, and the problems of parallel algorithms and biological computation.*



tially no new connections, placing severe constraints on models of learning. Even with all these constraints, connectionist models are increasingly popular in AI research.

**A VISUAL MODEL**

A simple example can capture some of the flavor of connectionist computation. The cube shown in figure 1 is a famous optical illusion attributed to the Swiss naturalist L. A. Necker (1832). Most people initially see the cube with the corner G closer to them, but you can also see it as a cube with vertex A closest to you. If you focus on vertex A and imagine it coming out of the paper toward you, the picture will flip to the A-closer cube. Notice that the flip takes less than a second. The Necker cube is interesting to psychologists because it will flip spontaneously between the two views if you keep looking at it. It is interesting to artificial-intelligence researchers because of what it tells us about parallel computation.

You have observed how quickly the Necker cube flips, and you know how slow the underlying human computing elements are. A sequential program running on such a slow device could probably not perform this task. But the situation is much more complex. Both human and computer vision require several levels of processing (see "Vision" by Dana H. Ballard and Christopher M. Brown on page 245). Typical levels include edge segments, lines, vertices, faces, and

object descriptions. The edges and lines are the same for both the A-closer and G-closer cubes, but many other visual features are seen differently in the two views. A few of these are given in figure 2. Remarkably, our visual system simultaneously flips all these perceptual decisions from one mutually consistent reading of the cube to the other. This illustrates the key cooperative property of massively parallel computation and why it is conceptually different from von Neumann computation on standard machines.

The Necker cube also illustrates some of the details of the connectionist paradigm, as shown in figure 2. In our models each item of interest is represented as a computational unit, with connections to many other units. Each unit has a level of activity (say between -10 and +10) and automatically sends the value of this activity along all its outgoing connections. In the network of figure 2, units that are mutually consistent (for example, "H closer than G" and "G hidden") have connections to each other. Units that are mutually exclusive, such as "G hidden" and "G showing" are connected with circle-tipped links denoting negative connections. The only other information needed for a complete model is the rule by which a unit computes its new activity from its inputs and its old activity. We can assume that the units compute the average of their positive and negative inputs. Networks like figure 2 are not

very sensitive to the exact choice of unit computation rules; this is one of the reasons for their attractiveness. Units that are all mutually connected by negative links are said to comprise a "winner-take-all" network. Such networks are one of the main decision mechanisms in connectionist models and have known neurophysiological analogs.

Much of the effort in massively parallel AI is dedicated to using computational frameworks like that in figure 2 to build models of intelligent activity. Advantages of this approach include its link to natural intelligence, increased noise resistance, and ease of implementation on parallel hardware. But the main advantage of the connectionist approach is that it provides a much better way of specifying some computations. I know of no other way to describe the Necker-cube phenomenon that is as clear and concise as the model in figure 2.

**A NATURAL-LANGUAGE APPLICATION**

Researchers in AI and related areas of cognitive science are using connectionist models to study a variety of tasks. Vision is an area where massive parallelism fits naturally. Ballard and Brown's article describes some of the success in that area. The methodology is also effective in natural-language research. Although it is a less obvious application, researchers have had some very nice results in that domain.

*(continued)*

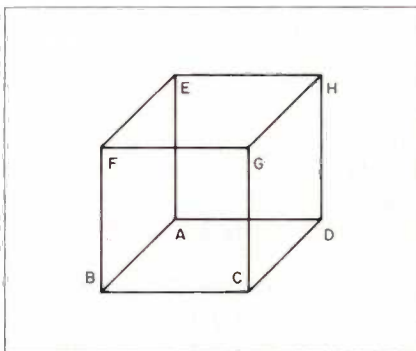

Figure 1: The optically illusive Necker cube. Is point A closer to you than point G, or vice versa?

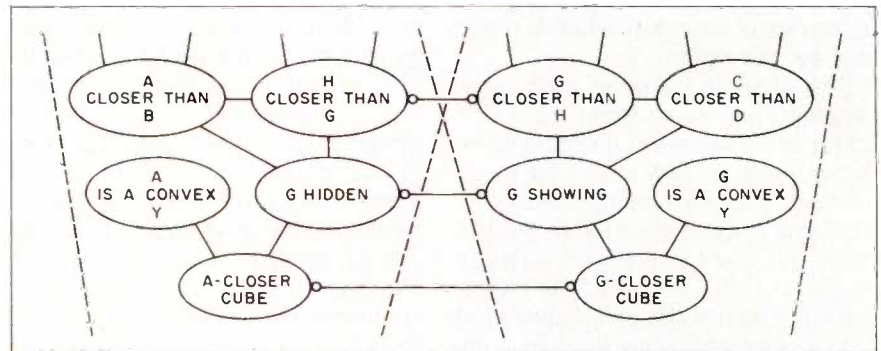
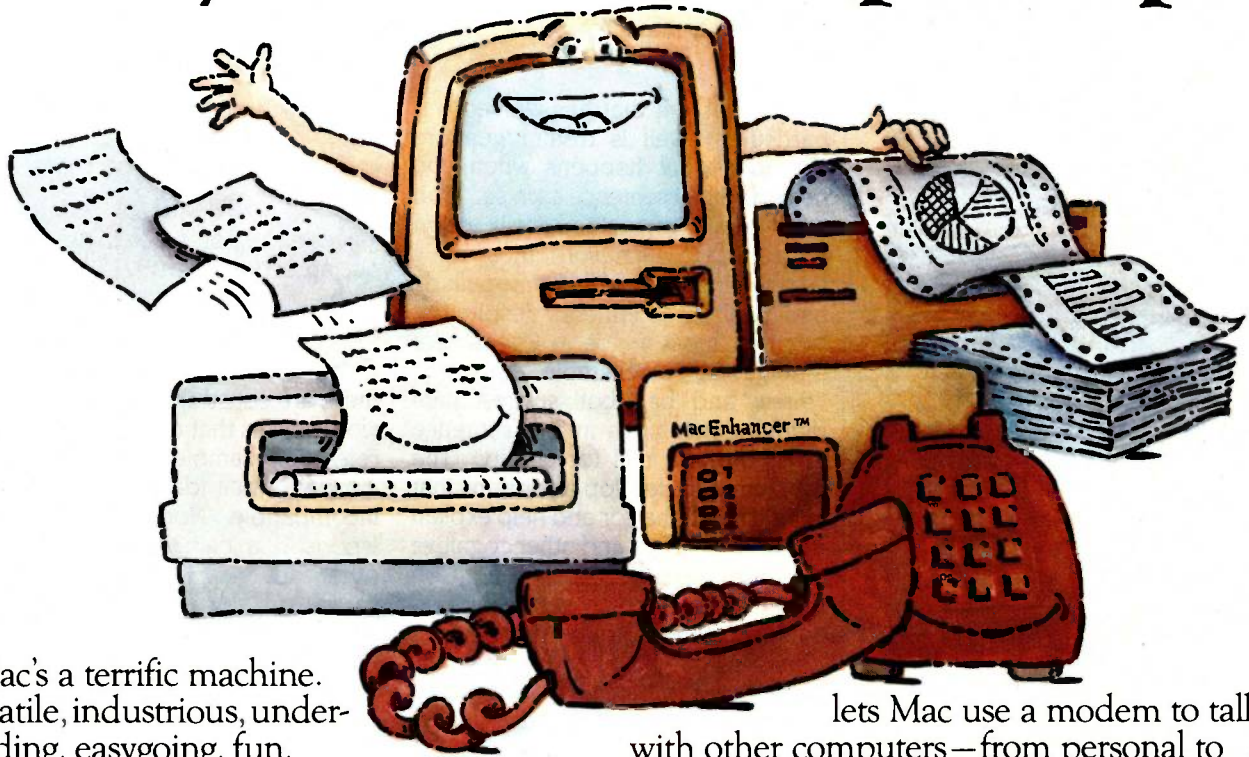

Figure 2: A connectionist model illustrating the process of understanding the cube in figure 1.

# Get your Mac to open up.



Mac's a terrific machine. Versatile, industrious, understanding, easygoing, fun.

Trouble is, Mac lives in a world of his own. He doesn't communicate well with his co-workers. Doesn't work well with them.

Now there's help.

The Microsoft® MacEnhancer™ expansion system can get him out of his shell. It'll open

lets Mac use a modem to talk with other computers—from personal to mainframes.

All without losing the loveable Mac personality. Just "point and click."

Getting Mac to expand his horizons wasn't easy, but somebody had

**MICROSOFT**  
The High Performance Software™

to do it. And who better than Microsoft? We've written more Macintosh™ programs than any other software company. Including Microsoft Word, Microsoft File. And Microsoft BASIC, Mac's first language.

For more information, or to free associate with your nearest Microsoft representative, call (800) 426-9400. In Washington State, Alaska, Hawaii and Canada, call (206) 828-8088.

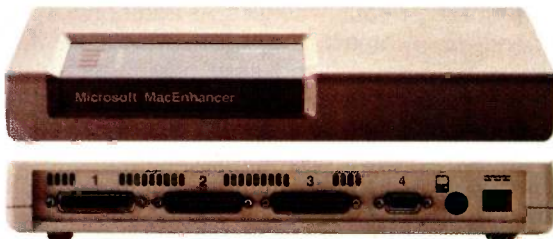

his communications channels. Expand his horizons.

MacEnhancer simply plugs into Mac's communication port. It lets you keep that original port while adding an IBM®-type parallel connector for your printer and two IBM-type serial connectors.

So now Mac can hobnob with even the finest letter quality printers. Cope with hyperactive dot-matrix printers.

And it comes with MacEnhancer terminal software. A communications program that

**SOFTWARE**



charity" will activate the "dance" meaning of ball. This will weaken the "sphere" meaning, which will in turn reduce the activity of "propel" because the sentence no longer has a suitable object. Thus, an alternative stable coalition develops and suppresses the original interpretation. The two alternative coalitions are quite similar to the two readings of the Necker cube. This is no accident—the idea of a cooperative-competitive network pervades parallel models. Work on language problems such as disambiguation is quite advanced and offers simple explanations of many phenomena. For example, a context that biased us toward the "dance" sense of ball would be modeled as providing that meaning with a head start in its competition with "sphere." Again, the massively parallel paradigm is the simplest way to express this idea.

**KNOWLEDGE REPRESENTATION**

The Necker-cube and disambiguation examples are both instances of what AI researchers call recognition problems. Several other problems are like this, but many are not. Can we apply massively parallel models to other traditional AI issues such as knowl-

edge representation and inference? Researchers have completed much less work along these lines but have made some promising starts. The example in figure 4 should convey the flavor of this work.

The standard way to explore the issue of knowledge representation and inference is in terms of programs that can answer questions. AI approaches to the development of question-answering systems are numerous (Roger Schank and Larry Hunter present one in "The Quest to Understand Thinking" on page 143), but the approaches all have the same basic requirements: You need a way to store the knowledge, to pose questions, and to compute and register the answers. In a connectionist model, all of these aspects must be expressed in terms of activity spreading among simple units like those in the previous examples.

It is easiest to start with the recording of answers. In figure 4, the possible tastes of foods form a winner-take-all network, where each unit inhibits the others so only one answer will be active. The answer network is assumed to be part of a routine that also poses the questions and acts upon the answer. The units that make

up the routine are assumed to be activated in sequence from left to right just like a standard program. The routine sends a question to the knowledge network by activating the appropriate units; figure 4 shows this as links, for example, from the hexagonal node to the nodes for "has-taste" and "ham." The key to the operation of this network is the operation of the triangular-shaped nodes, such as "b1." We define such a triangular unit to become active when two of its inputs are simultaneously active. In this case "ham" and "has-taste" are both on, so "b1" becomes active and activates "salty." Now the "salty" node in the knowledge network spreads activation to the response "r-salty" back in the routine and the question is answered. The same network can answer questions such as "Name a salty meat" when activated appropriately. The answers returned by such a network will depend on context, just as people's answers do; contextual bias is again modeled by activation.

The examples of cube perception, word disambiguation, and question answering are typical of the current applications of massively parallel computational models in AI. The examples are condensed and they omit many important considerations, but they are representative of the current level of attainment. In no case are the connectionist programs as sophisticated as conventional AI systems for similar tasks. The general notion of massively parallel models in AI is quite new, and we do not yet understand where its ultimate strengths and weaknesses will lie. We do know that the development of highly parallel computers will have a marked effect on the practicality of connectionist approaches to AI.

Even if we had discovered parallel algorithms for vision and language tasks and could run them efficiently on parallel hardware, we would be missing a crucial element of intelligence—learning. No system that cannot incorporate new knowledge and change its behavior could be called intelligent. This is an important issue

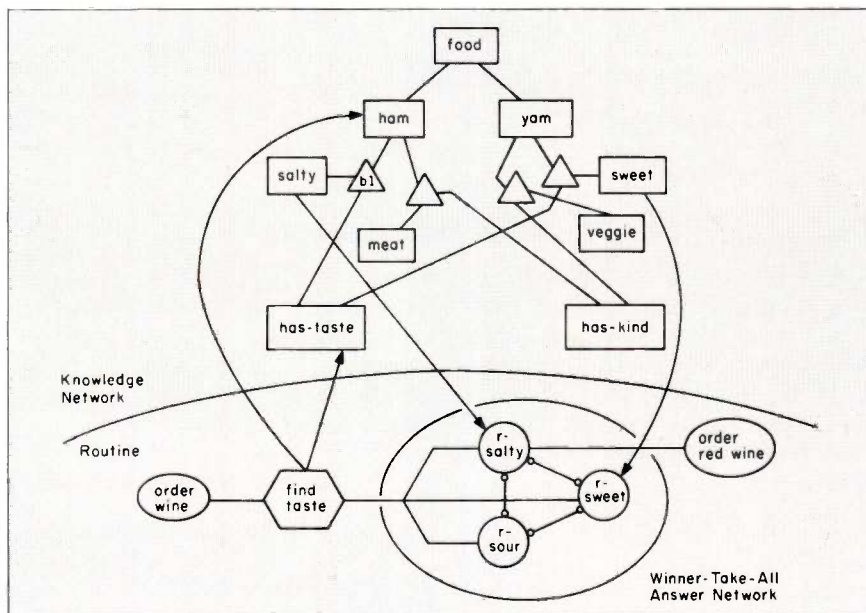

Figure 4: Interaction between a knowledge network and a routine.

(continued)

# The new Canon TX-50 desktop computer. It fits any customer's business as well as his desk.



No matter how specialized your customers' business needs, Canon's new compact desktop computer is uniquely designed to accommodate them.

Because the TX-50 is a self-contained computer that can be customized for a wide range of specific business applications.

Its all-in-one design includes:

- A high-performance 16-bit microprocessor with MS-DOS† operating system. Standard 128KB memory is expandable to 256KB.
- Seven-inch high-resolution monochrome CRT display.
- Fifty-function LED keyboard plus separate ten-key calculator pad and cursor control keys.
- Three-inch compact floppy disk drive with 150 K-bytes memory capacity per side.
- Optional RS-232C serial interface and Centronics-type parallel interface available.
- Wire dot impact printer that gives a

sharp 5X7 dot matrix and has a maximum 30 characters per line. It prints a black or red original on plain paper plus two copies.

With such impressive, self-contained flexibility, the TX-50 is ideal in areas such as customer operations and counter service. Especially since the TX-50 provides such a huge range of varied functions, yet takes up so little space.

Businesses such as gasoline stations, banks, mail rooms, real estate brokers and numerous others will find the TX-50 particularly useful for sales, credit, loan or general customer calculations.

So if you're dealing with business, whether large or small, and you feel they need a rather special computer, consider the new Canon® TX-50 desktop computer.

There isn't a desk it won't fit.

**For more information:**  
Call 1-800-323-1717, Ext. 302.  
(In Illinois call 1-800-942-8881, Ext. 302.)  
Or write Canon U.S.A., Inc.  
Systems Division/TX-Series  
P.O. Box CN 11250, Trenton, N.J. 08650

**Canon Systems Division**

© 1985 Canon U.S.A., Inc.  
†MS-DOS is a trademark of MICRO SOFT.



for all of AI but is especially critical for connectionist models. If we model our system as a set of rules, we'll have no conceptual difficulty in adding more rules, although the question of which rules to add remains unsolved. For connectionist models, the intelligence is in the connections—but we know that the brain grows essentially no new connections. How could such a system, even in principle, incorporate new knowledge?

The neural substrate of memory and learning is one of the great unsolved scientific questions for which we certainly have no definitive answers. But connectionist theories of learning are compatible with current brain research and are computationally feasible. The key idea is that while new connections are rare, *weight change* in connections appears to be common. We also know that each unit can have thousands of incoming and out-

going connections. Our hypothesis is that most of these connections are only potentially important and that learning involves strengthening the appropriate connections. Suppose, for example, the network of figure 4 needed to learn that spinach was a salty vegetable. Our model suggests that there are uncommitted triangular nodes that are weakly connected to many combinations of objects, properties, and values. In an ideal case, one of them will be linked to "spinach," "has-taste," and "salty," among other things. This unit will become highly activated by the simultaneous activation of three of its neighbors and, by strengthening its active connections, can become dedicated to the new association. This example omits many important issues; the whole learning theory is in a very primitive stage. Geoffrey Hinton, in the article "Learning in Parallel Net-

works" (page 265), describes a related but different learning scheme based on the assumption that concepts are represented diffusely as the activity of many, many units. All of the connectionist AI efforts badly need more theoretical and experimental work, which leads us to an active interest in parallel computers.

**PARALLEL COMPUTERS**

Clearly, massively parallel AI models have a natural fit to parallel computers. The speed of our current simulations on sequential machines is slow enough to be a major bottleneck. While some kinds of programs are hard to transfer to parallel computers, connectionist simulations are straightforward to move. If we have 100 processors and a network of 20,000 units to simulate, we just assign 200 units to each processor. There are technical questions about the best way to partition the network, but the basic idea is simple. It is less clear how to monitor and modify the behavior of such systems, and this leads to basic research questions in parallel computation. A number of machines with hundreds of processors are being built in various labs. Our group at the University of Rochester is working with the Butterfly multiprocessor of Bolt Beranek and Newman; we expect to have a 128-processor system running this summer. A parallel version of our connectionist simulator is one of the major driving applications for the Butterfly.

Possibly the best way to program many problems for a multiprocessor is to express them as a massively parallel network. While breaking a problem into 256 equal pieces is difficult, it may be fairly easy to express the problem's natural parallelism and let a compiler map the result onto whatever hardware is available. This seems to be the experience of the Cal Tech group on the physics problems they have attacked, and it appears to be true for many AI problems. The success of this approach could be a coincidence, but it might be related to the fact that intelligence evolved on massively parallel hardware. ■

**INSTANT FINANCIAL PICTURE!**

Corporate Financial Simulation Model on your IBM PC, XT or AT with Lotus 1-2-3, Multiplan, SuperCalc, VisiCalc or PeachCalc. Also available on most PC/M & all Apple systems. A \$6,000 value for \$295.

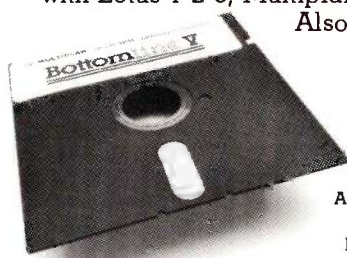

**Bottomline V**

A Financial Decision Support System - budgeting, planning, analysis, and five-year forecasting. Now used nationwide by Peat, Marwick, Mitchell & Co. ("Big 8" accounting firm).

Fill out this card and mail for complete details, or call 1-800-828-7257, CA only 1-800-523-7201, or 714-476-2842 for UPS COD delivery.

- Send more information
- My check for \$10 is enclosed. Please send me a (circle one) **black and white/color** Demo for my IBM PC.
- Please send me Bottomline V for \_\_\_\_\_ Spreadsheet on the \_\_\_\_\_ computer. My check for \$295 plus \$5 for shipping and handling is enclosed.

Name \_\_\_\_\_ Title \_\_\_\_\_  
 Company \_\_\_\_\_ Phone \_\_\_\_\_  
 Street \_\_\_\_\_  
 City \_\_\_\_\_ State \_\_\_\_\_ Zip \_\_\_\_\_

Mail to: **ILAR Systems, Inc.** • 1300 Dove St., Suite 105 • Newport Beach, CA 92660  
 Inquiry 195 for Dealers. Inquiry 196 for End-Users.

# The new Canon® Handy Terminal makes any computer system go farther.

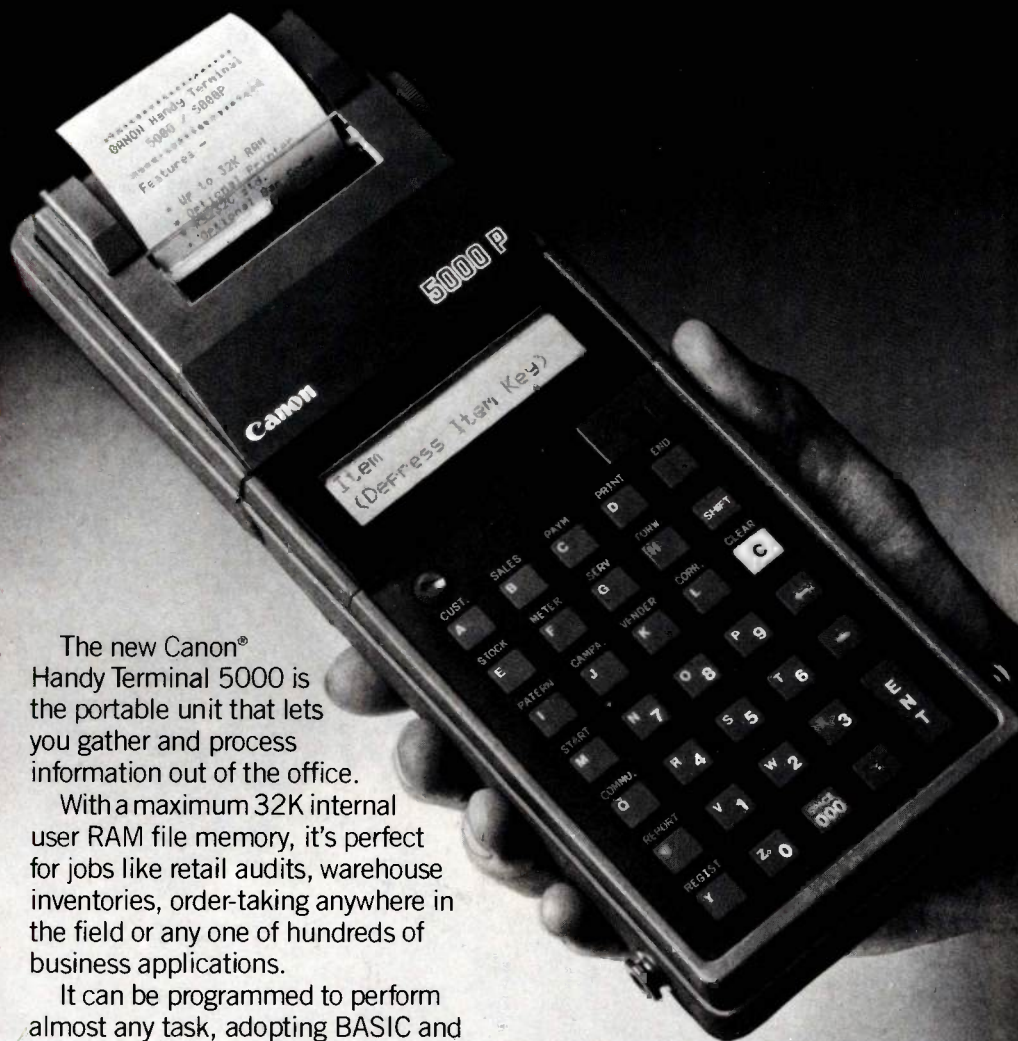

The new Canon® Handy Terminal 5000 is the portable unit that lets you gather and process information out of the office.

With a maximum 32K internal user RAM file memory, it's perfect for jobs like retail audits, warehouse inventories, order-taking anywhere in the field or any one of hundreds of business applications.

It can be programmed to perform almost any task, adopting BASIC and Assembler languages.

And can even relay information to your computer via phone hookup.

Portability is also the key word of the 5000, because Canon's Handy Terminal was especially designed for traveling light.

At a weight of less than 2 lbs., it can operate on a rechargeable battery and can be carried by neck strap or in an attache case. Yet it's highly durable, water resistant and shock resistant. Which means it can take its fair share of hard knocks.

© 1985 Canon U.S.A., Inc.

Also available is the 5000P (shown above) which has a built-in thermal dot printer that can print one original and a copy.

And both terminals can incorporate an optional bar code reader.

So why not widen your computer horizons with Canon's new Handy Terminal. It lets you go as far as you like.

**For more information:**  
Call 1-800-323-1717, Ext. 302.  
(In Illinois call 1-800-942-8881, Ext. 302.)  
Or Write Canon U.S.A., Inc.,  
Systems Division/Handy Terminal,  
P.O. Box CN 11250, Trenton, N.J. 08638.

**Canon Systems Division**





Photo 1: A scanning electron micrograph of brain cells grown in tissue culture on a Motorola 68000. The center clump of balls is a group of somas, and the thin lines radiating outward from the clump are the neural processes. The IC traces are 2 to 5 microns across, and the traces on the nerve processes taper to less than 0.2 micron across.

# REVERSE ENGINEERING THE BRAIN

BY JOHN K. STEVENS

## *Chipping away at the brain*

COULD WE DEVELOP more efficient "sixth-generation" artificial-intelligence (AI) computers using circuitry copied directly from the brain, perhaps using radical new architecture, new hardware, and an entirely new logic? This question seems to have been raised about once a year for the last two decades. The answer continues to be "Probably not right away," but as our understanding of principles used in neural processing evolves, it is a possibility that must be taken seriously. Moreover, some new digital designs such as the Boltzmann machines (see "Learning in Parallel Networks" by Geoffrey E. Hinton on page 265) closely parallel the overall architecture of the brain.

First we will review what might be called the device physics of the brain, focusing on the physical and electrical principles that optical nerve cells use to process information. Then we will discuss how silicon-based designs might be adapted to make use of the brain's approach and how such designs might be used in some high-speed processing applications.

While today's digital hardware is ex-

tremely impressive, it is clear that the human retina's real-time performance goes unchallenged (table 1). Actually, to simulate 10 milliseconds (ms) of the complete processing of even a single nerve cell from the retina would require the solution of about 500 simultaneous nonlinear differential equations 100 times and would take at least several minutes of processing time on a Cray supercomputer. Keeping in mind that there are 10 million or more such cells interacting with each other in complex ways, it would take a minimum of 100 years of Cray time to simulate what takes place in your eye many times every second. How does this impressive piece of "bio-ware" work?

### **A BRIEF INTRODUCTION TO NERVE CELLS**

The retina's nerve cells function as complex analog processors. The connections between these cells, the characteristics of their connections, and the shape of the cells themselves all seem to play a major role in determining the basic parameters of the analog processing "program."

Nerve cells come in many different shapes and sizes, but they can be placed into two broad categories—local processing "interneuron" cells and output cells. The local processing cells have all of their inputs and outputs limited to a very small region (usually a few hundred microns), while the output cells communicate from one part of the brain to another, from the brain to muscle, or from sensory organs to the brain.

The nerve cell, or *neuron*, can be thought of as a stand-alone analogical processing unit. Each cell has an inside and an outside separated by a plasma membrane. The inside of the cell and the fluid surrounding the cell have different concentrations of

*(continued)*

*John K. Stevens, Ph.D., is an associate professor of physiology and biomedical engineering at the Playfair Neuroscience Unit (University of Toronto, Toronto Western Hospital, 399 Bathurst St., Toronto, Ontario M5T 2S8, Canada). He is also cofounder of a company called Telepanel, which develops hardware and software for the retail sales industry, and is a member of the Canadian Institute of Advanced Research.*



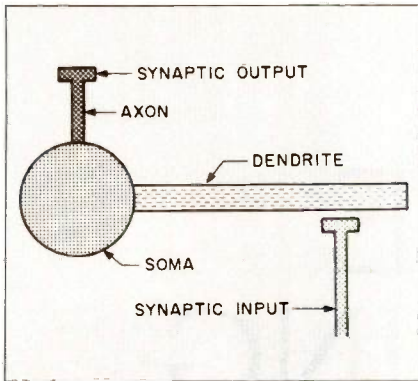

Figure 1: A summary overview of a typical nerve cell.

charged ions, which creates a potential difference across the membrane. The concentration of the inside ions is controlled by many "ion pumps" located in the membrane itself. The ion concentration of the fluid surrounding the cell is just filtered blood and is regulated by special ion pumps found in the kidneys. These differential ion concentrations provide the electrical energy for all nerve cells and are exactly analogous to a battery. The full circuit requires a resistor in series with the battery to represent the ion leakage across the plasma membrane. The active pumps in the

cell's membrane and kidneys are analogous to a battery charger, but instead of using a 110-volt wall plug, they use glucose or other nutrients as the power source.

### THE SOMA

Each cell has a large round central body called a *soma* (photos 1 and 2, figure 1) that contains the genetic and metabolic machinery necessary to keep the cell alive. The soma takes the glucose found in the surrounding fluid and converts it to a more usable form of energy called ATP (adenosine triphosphate). The ATP drives the active pumps directly. The soma also synthesizes lipids and proteins that are used to maintain the cell's membrane, synapses, gates, and the nerve-process skeleton (cytoskeleton).

Table 1: A comparison of specifications for a hypothetical image-processing system using state-of-the-art integrated circuitry and the human retina.

Specification	Typical IC Product	Retina
circuit layout	two-dimensional	three-dimensional
IC line width	1-3 microns	0.1-1.0 micron
number of gates	approx. 1,000,000	approx. 25,000,000,000
resolution (pixels)	2048 x 2048	10,000 x 10,000
PC board trace width	250 microns	0.2-3.0 microns
power consumption	200-300 watts	0.001 watts
system volume	approx. 10,000 cu.in.	approx. .0003 cu.in.
total weight	20,000-50,000 g	<1 g.

### THE PASSIVE DENDRITE

Attached to the soma are long, irregularly shaped nerve processes (hair-like projections) called *dendrites*. These dendrites often have diameters under 1 micron and extremely complex branching shapes. Dendrites are electrically passive and can be represented as a series of capacitors and resistors. Their primary function is to receive inputs from other cells via specialized contacts called *synapses* or to connect other dendrites to synaptic outputs. One very important point that we will discuss in some detail is that the shape of a dendrite can have a dramatic effect upon the time course and final potential of any synaptic input. Thus, the same synaptic input on two differently shaped dendrites can have dramatically different effects. Synaptic inputs on a dendrite can either be summed and passively conducted to local synaptic outputs located on the same dendrite (in interneurons) or passively conducted back to the soma, where an action potential may be initiated in output cells.

### THE ACTIVE AXON

A second type of nerve process also attached to the soma is called an *axon*. The axon differs from the dendrite in that it is electrically active and can

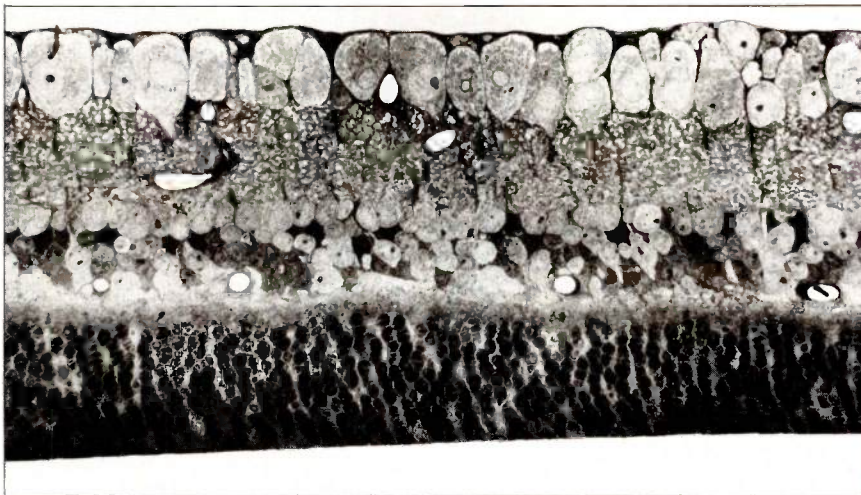

Photo 2: An electron micrograph of a cross-section of retina about 0.1 micron thick and about 200 microns by 500 microns across. The light would activate the receptors (located at the bottom of the picture), and the final output would come from the top at the ganglion cells. The large round objects are somas, or cell bodies, and the very small profiles layered between the cells are nerve processes that make synaptic contacts with each other. Sequential series of the micrographs are used to reconstruct cells similar to those seen in figure 7.



serve as the final output channel of the cell. Axons are always found on the output cells but often do not appear on interneurons, particularly on interneurons that have both inputs and outputs on dendrites. The axon is a nonlinear threshold device that produces a rapid, all-or-none voltage increase and decrease of about 1-ms duration. This voltage pulse, which is called an *action potential*, has a fixed amplitude and occurs when the resting potential within the soma rises above a critical threshold. The rapid changes in potential associated with the action potential are due to specialized proteins contained in the axon's membrane that selectively allow sodium and potassium ions to flow across the membrane, down their concentration gradients. You might think of these action potential gates as simply a series of interconnected one-shots.

Anatomically, the gates begin on the soma just before the actual axon leaves the cell. When the synaptic inputs located on the dendrite of a cell are activated, the potential may be passively conducted to the soma near the axon. If the sum total of all of these inputs as seen by the soma or axon is above the threshold of these gates, they will be activated and produce an action potential. Once this first group of gates has been activated, they change the internal axonal potential even more and activate the next set of gates located farther down the axon. These more distant

gates raise the axonal potential again and activate even more distant gates, and so on, for the entire length of the axon, up to many feet in total length.

**SYNAPTIC INPUTS AND OUTPUTS**

Axons terminate in specialized contacts, called synapses, on other nerve cells. Synapses make contact with the dendrites of other cells and are capable of changing a dendrite's local potential in a positive or negative direction. When the potential on the axonal side (the presynaptic side) is raised, special compounds called neurotransmitters are released. Their release seems to be graded as a function of the presynaptic voltage waveform. Neurotransmitters are capable of opening gates similar to those described above for the action potential, except that these gates are located on the dendritic membrane and are activated chemically. When a synaptic gate is open, it selectively allows charged ions to flow across the membrane, either into or out of the cell. This in turn changes the internal dendritic potential. The total number of gates opened depends upon the total number of transmitter molecules released. A given synapse may excite or inhibit a cell. A single cell will always have many synaptic inputs on its dendrites and may have many synaptic outputs on its axons or dendrites to many different cells.

The output synapses from output cells are always located on the end of

an axon. However, the output synapses from interneurons are located on the passive dendrites near the input synapses. Since the action potential has a fixed waveform, the synaptic outputs from the axon of an output cell will also have a fixed waveform. In contrast, since the potentials inside a dendrite are graded analog signals (due to analog summation of many different synaptic inputs), the interneuron synaptic outputs may also be graded. Thus, output cells have graded analog inputs with digital, all-or-none final outputs; interneurons have graded analog inputs but also have graded analog outputs.

**THE METHODS**

Advanced recording methods that depend upon submicron electrodes placed near individual cells in living brains and in tissue culture have taught us a great deal about the function or what could be called the software and hardware of brain cells. These electrodes make it possible to record action potentials and in many cases penetrate the soma and record intracellular potentials from synapses that have been activated on a peripheral dendrite. It has also been possible through other methods to measure the physical characteristics and properties of nerve cells, individual portions of cells, and even the properties of membranes and proteins embedded in the mem-

*(continued)*

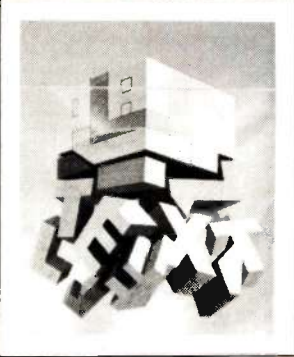

**Through the Trap Door**  
March 1979—\$40



**Breaking the Sound Barrier**  
September 1977—\$40

## BYTE COVERS

The prints shown at left are beautiful Collector Edition Byte Covers, strictly limited to 750 prints each, and signed and numbered by the artist, Robert Tinney. Each print is 18 in. x 22 in., and is accompanied by its own Certificate of Authenticity. To order, use the coupon below. Visa and MasterCard orders may call 1-504-272-7266.

Please send \_\_\_\_\_ **Through the Trap Door** prints (\$40), \_\_\_\_\_  Visa  MasterCard  
**Breaking the Sound Barrier** prints (\$40), or \_\_\_\_\_ sets of both prints (\$65). I have included \$3 per order shipping and handling (\$8 overseas). Card No. \_\_\_\_\_  
 Expires: \_\_\_\_\_  
 Name: \_\_\_\_\_  
 Address: \_\_\_\_\_  
 City: \_\_\_\_\_  
 State: \_\_\_\_\_ Zip: \_\_\_\_\_  
 I have enclosed check or money order.  
 Please send me your color brochure.

**Robert Tinney Graphics** • 1864 N. Pamela Dr. • Baton Rouge, LA 70815



# magnum p.c.

800-544-4354 BY4

**VISA** GA Residents **MasterCard**  
(404) 441-3112

5965 PEACHTREE CORNERS E. B-2, NORCROSS, GA 30071

## COMPUTERS

IBM PC YOU CONFIGURE..... CALL  
SANYO MBC & SUPER..... NEW LOW PRICES

## BOARDS

AST SIX PAC PLUS (64K) / MP MINI.....259/NEW  
EVEREX GRAPHICS EDGE.....399  
HERCULES GRAPHICS CARD.....335  
IRMA 3278 EMULATOR..... BEST PRICE  
MICROTEK NEW PRODUCTS..... CALL  
ORANGE MICRO ALL BOARDS..... CALL  
ORCHIO PC BLOSSOM & TURBO..... CALL  
PROFIT SYSTEMS MULTIGRAPH..... CALL  
PERSYST BOARDS & CARDS..... SAVE  
QUADRAM QUADBOARD / MAXPAQ.....259/CALL  
STB GRAPHIX PLUS II..... CALL  
TECMAR GRAPHICS MASTER/JR CAPT 469/325  
TITAN ACCELERATORS FOR IBM OR APPLE.....CALL

## DISK DRIVES

FULL HEIGHTS (FOR IBM)..... FROM 110  
HALF HEIGHTS (FOR IBM)..... FROM 125  
ALPHA OMEGA TURBO 10 (FASTER THAN XT)800  
EVEREX 10 MEG INTERNAL HARD DISK..... 649  
20 MEG INTERNAL HARD DISK..... 1139  
1/2 HT 1/4" TAPE STREAMER.....960  
IOMEGA BERNOULLI BOX (20 MEG).....2795  
MICRO SCI (FOR APPLE)..... FROM 199  
PCjr 2ND DISK DRIVE BY QUADRAM.....495  
PEACHTREE PERIPHERALS..... CALL  
QUADDISK 6 MEG REMOVABLE.....1725  
QUENTIN (FOR APPLE & IBM)..... SAVE  
SEAGATE 25MEG FOR AT.....795  
SUPER 5 (FOR APPLE).....179  
TALLGRASS HARD DISK WITH BACKUP..... CALL  
TANDON TM100-2.....189 10 MEG HARD..... CALL

## PRINTERS

BROTHER HR-15, HR-25, HR-35..... CALL  
C. ITOH LETTER QUALITY..... CALL  
EPSON FX, RX..... CALL FUJITSU..... SAVE  
NEC SPINWRITER, P2 & P3..... CALL  
OKIDATA ALL MODELS..... BEST PRICES  
PANASONIC..... SAVE OUME..... CALL  
STAR MICRONICS GEMINI 10X/15X..... 269/379  
TEXAS INSTRUMENTS..... CALL  
TOSHIBA P1351 & P1340.....1249/795

## MONITORS

AMDEK 300A or 300G.....154/144  
PRINCETON GRAPHICS HX12/SR12...469/CALL  
QUADRAMQUADCHROME/AMBERCHROME CALL  
SUPER 5..... CALL TAXAN ALL MODELSCALL

## SOFTWARE

COPY II PC..... SAVE D-BASE III.....399  
FRAMEWORK.....399 WORDPERFECT CALL  
LOTUS 1-2-3.....309 MULTIMATE.....279  
SYMPHONY.....475 WORDSTAR 2000CALL

## MODEMS

HAYES SMART MODEM 300/1200.....212/489  
NOVATION SMART CAT PLUS W/MITE..... 349  
VEN-TEL HALF CARD 1200 BAUD.....425  
U. S. DIGITAL.....395 MAXWELL.....SAVE

## ACCESSORIES

CHIPS 64K - SET OF 9.....39  
COMUSERVE STARTER KIT.....32

## DISKETTES

BASF 5 1/4 SS/DD (Each - lots of 10).....1.45  
5 1/4 DS/DD (Each - lots of 10).....2.50  
IBM AT (Each - lots of 10).....4.90  
VERBATIM 5 1/4 DS/DD (Each - lots of 10).....2.40  
MAXELL5 1/4 DS/DD (Each - lots of 10).....2.25

AVAILABILITY AND PRICES SUBJECT TO CHANGE  
APPROVED CORPORATE ACCOUNTS WELCOMED

## THE BRAIN

branes. Until recently, it has been difficult to incorporate these physical parameters into a comprehensive model of submicron device physics, or what we call the design rules of the brain.

As I mentioned, the shape of nerve-cell processes plays an important role in controlling their function. Unfortunately, these processes are almost always well below 1 micron in diameter. A major difficulty has been that to accurately create an electrical or physical model of a nerve cell requires a detailed knowledge of surface area, length, and branching patterns of all processes and location of synaptic inputs. Because the cells are small and have extremely complex three-dimensional geometries, these parameters cannot be accurately obtained using the light microscope, which has a resolution of only about 1 micron. The scanning electron microscope allows us to see cells at higher resolution, but the cells must

be removed from their circuit in the brain and placed on a special flat substrate or grown in tissue culture directly on the substrate.

Thus, scanning microscopes cannot be used to analyze intact three-dimensional circuits of the brain. The transmission electron microscope has more than adequate resolution. But to see the cells at high resolution, they must be sliced into very thin sections, usually less than 0.1 micron (photo 2). Thus, while the submicron structure can be resolved, the three-dimensional structure of the cells is lost.

The solution has been to simply slice the brain into thin serial sections and then, by using special computer systems, to reassemble the individual cross-sections into a full three-dimensional reconstruction of the original object (figure 2). Technological advances over the last few years have made this almost routine, so it

(continued)

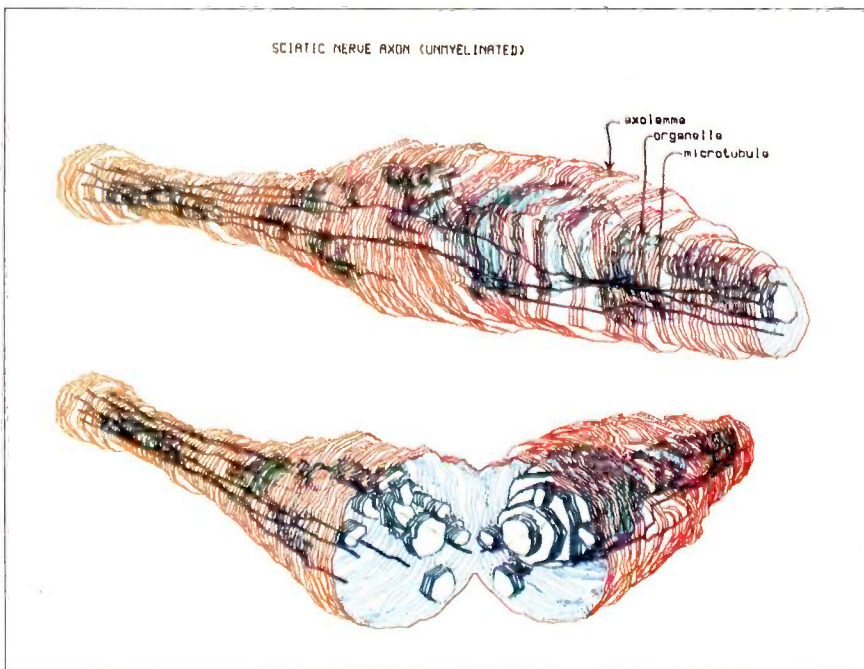

Figure 2: Electron microscopic reconstruction of an axon. The internal structure of a dendrite would be similar. The long tubes (microtubules) and round green objects (organelles) play a role in controlling the local geometry of the nerve process. This process, reconstructed by M. Greenberg (Playfair), has a diameter of about 1 micron. Reprinted by permission of Academic Press from *Advances in Cellular Neurobiology* (see Bibliography).



**TOLL FREE  
ORDERS ONLY! 800-631-0962**  
**(INSIDE CALIFORNIA) 800-521-6162**

**Customer Service HOTLINE  
(408) 559-6555**

# GUARANTEED <sup>the</sup> LOWEST!

OUR PRICE GUARANTEE - It's Simple! We'll beat any ad in this magazine - same terms - call TOLL FREE for details!

**DCC**

**DISCOUNT COMPUTER CENTERS**

OUR CUSTOMER SATISFACTION GUARANTEE: If for any reason your DCC purchase fails to meet manufacturers specifications within 30 days of purchase, please return it to us for a full refund or exchange of your choice! Sorry, software excluded due to copyright laws.

**EPSON all models!**  
RX/FX and LQ1500  
also NEW JX80  
(7 colors)

**PRINTER SALE!!!**

**OKIDATA**

models 82/83/84 and 92/93!! also 2410 (350 cps!)

**IBM PC** \$1650  
or 2 drives/256K, 10 mg hard disk

**IBM XT** \$3395  
10 mg. hard disk  
256K, 1-360Kb drive only

**HR-15 XL \$359**  
**BROTHER**  
\*\*LETTER QUALITY\*\*  
• High Speed 36 cps  
• 7K Buffer

**HR-35**

**COMPUTERS**

See special above!!!

PC with 1 drive/64K ..... 1395  
PC with 2 drives/256K ..... 1650  
XT with 10 mg HD/128K ..... 3350  
XT with 2 drives/10MG ..... 3475

Call for details - Compatible brand portables and desktops

**PRINTERS**

\*\*\*\*\*DOT MATRIX\*\*\*\*

EPSON RX 80 100 cps ..... 235  
RX 80 FT 100 cps ..... 279  
RX 100 100 cps, 132 col. .... 399  
FX 80 or JX 80 ..... best price  
FX 100 160 cps, 132 col. .... in  
LQ 1500 200 cps NEW! ..... magazine

OKIDATA 82A/83/84 ..... Save  
92P ..... All  
93P ..... Models

2410 ..... Draastically Reduced!!  
GEMINI 10-X ..... 238  
15-X ..... 349  
DELTA 10 or 15 ..... Special  
RADIX 10 or 15 ..... \$Call

**IBM SOFTWARE**

TEAC 1/2 HI-360 KB ..... 119  
SHUGART 1/2 HI-360 KB ..... 109  
COGITO 10 MG H.D. W/CONTROL ..... 665  
ATARI INDUS GT ..... 349

**IBM - BOARDS**

PINBALL ..... 39  
MATHBLASTER ..... 45  
FROGGER ..... 28  
ULTIMA III ..... 35  
ZAXXON ..... 35  
GATO SUB SIMULATOR ..... 35

**APPLE - BOARDS**

ORANGE MICRO GRAPPLER + ..... 113  
BUFFERED w/ 64K ..... 168  
MICROMAX GRAPHMAX ..... 99  
VIEWMAX 80 ..... 139  
VIEWMAX 80E W/64K ..... 189  
MAC DISKETTES ..... 48  
IIC PRINTER INTERFACE ..... 59  
SUPER COOLING FAN ..... 49

**MONITORS**

NOW IN STOCK

IBM MONOCHROME ..... 249  
COLOR ..... 459  
AMDEK 300G ..... 569  
300A ..... 135  
310A ..... 145  
COLOR 600 ..... 165  
COLOR 710 NEW ..... 419  
TAXAN 12" Green ..... 515  
12" Amber ..... 114  
420 RGB ..... 117  
PRINCETON HX-12 ..... 439  
SR-12 ..... 459  
MAX-12 ..... 649  
ZENITH 122 - 12" G ..... 168  
12" A ..... 93  
124 MONO - IBM ..... 93  
135 RGB/COMP ..... 169  
POLO 16 COLOR RGB!! ..... 475  
350

\*\*\*\*\*DAISY WHEEL\*\*\*\*

PRIMAGE I 55 cps, SER/PARR ..... 1395  
w/Cut Sheet Feeder ..... 1695

BROTHER DAISY WHEEL

HR-15 XL ..... 359  
HR-25 ..... 599  
HR-35 (36 cps) ..... 799  
JUKI 6100 ..... 389  
JUKI 6300 ..... 724  
DIABLO 620 ..... 829  
36 ..... 1276  
630 ..... 1689  
DYNAX DX-15 ..... 359  
NEC all models ..... \$Call  
QUME all models ..... \$Call

\*\*\*\*\*SPREADSHEET\*\*\*\*

FRAMEWORK Monthly Special ..... 355  
FRIDAY ..... 195  
SUPERCALC 3 ..... 228  
MULTIPLAN ..... 136

\*\*\*\*\*IBM WORDPROCESSORS\*\*\*\*

WORDSTAR PRO PACK ..... 249  
PFS WRITE ..... 84  
MULTIMATE ..... 249  
WORD W/MOUSE ..... 269  
VOLKSWRITER DELUXE ..... 159  
PFS PROOF ..... 84

\*\*\*\*\*IBM DATA BASE\*\*\*\*

gBASE II ..... 284  
gBASE III ..... 355  
PFS FILE ..... 84  
CONDOR III ..... 249  
R-BASE 4000 ..... 279  
R-BASE CLOUT ..... 129

**ACCESSORIES**

PRINTER RIBBONS all makes ..... Low!!  
64K RAM chips SALE ..... 35  
VERBATIM SS/DD diskettes ..... 21  
DS/DD diskettes ..... 27  
DYSAN SS/DD diskettes ..... 26  
DS/DD diskettes ..... 34  
DISK MINDER-PLEXI (75) ..... 19  
DISK MINDER W/KEY (100) ..... 24  
SURGE PROTECTOR Compugard ..... 59  
PTI POWER BACK-UP 200 w ..... 275  
300 w ..... 355

FINGERPRINTS - EPSON all models ..... 48  
PRINTER DUST COVER all models ..... 10  
MON-BASE Monitor Stands ..... 19  
COMPUTER PAPER all makes ..... Low!!  
PRINTER STANDS Plexiglass ..... 29/39  
SURGE PROTECTORS ..... \$Call

**MODEMS**

HAYES 300 ..... 195  
1200 ..... 459  
1200B IBM INTERNAL ..... 389  
MICROMODEM II E ..... 209  
ANCHOR MARK XII ..... 244

**DRIVES**

IBM 360 KB ..... 219  
TANDON 100-2 360KB ..... 165  
APPLE DRIVES Sale ..... 135

**IBM ACCESSORIES**

64K RAM CHIPS 200ns ..... 35  
150ns ..... 35  
IBM KEYBOARDS ..... 159  
KEYTRONICS S151 NEW! ..... 179  
5150 ..... 159  
MICRO-SOFT MOUSE ..... 129  
MOUSE SYSTEM-MOUSE ..... 124  
KOALA PAD ..... 85  
JOYSTICKS - KRAFT/HAYES ..... 45

**ATARI/C-64**

ACCESSORIES low, low ..... CALL!!  
C-64 CARDCO + G ..... 79  
ATARI MP1150 ..... 94  
APE FACE ..... 69  
GRAPPLER CD COMMODORE ..... 99

**AST \$229**  
**SIX PAK PLUS**  
w/64K RAM **\$249**

**10 MG 1/2 HI INTERNAL \$665**  
**HARD DISK**  
\*\*\*\*\*SPECIAL\*\*\*\*  
w/controller card and cables!!!  
**\$1099** 20 MG Internal

**WORDSTAR**  
• All new-easy to use  
• "Windows"  
• Footnotes  
• Spell Checker  
• Much, much more  
**\$259**

mouse systems' w/PC PAINT **\$124**  
**MOUSE** **\$129** micro-soft

Color Graphics Card **\$165**  
**HERCULES**  
Micro Graphics Card **\$309**

# DCC DISCOUNT COMPUTER CENTERS

an established mail order/retail distribution network

**BUYER FRIENDLY TERMS!** • DELIVERY We ship immediately! Most orders delivered within 5 days! Add 3% (\*5% min) for UPS shipping, handling, insurance. Calif. residents add 6.5% sales tax. 2<sup>nd</sup> day UPS available at extra charge. • PAYMENT Visa, M/C, cashiers checks, money orders, personal checks accepted. (Allow 10 business days for personal/company checks to clear). WE NEVER CHARGE EXTRA FOR CREDIT CARDS! C.O.D.'s welcome (20% p/p deposit) with cash, certified check or money order. • WARRANTY All items shipped are new, include FACTORY WARRANTY and are GUARANTEED TO WORK. DCC is an AUTHORIZED DEALER and SERVICE CENTER for most major brands. • RETURNS Must be accompanied by RMA number (supplied by DEALER) and may be subject to a 20% restocking fee. Prices and availability subject to change without notice. All items limited to stock on hand. • MAIL ORDER PRICES NOT VALID AT RETAIL OUTLETS DUE TO REGIONAL PRICING RESTRICTIONS. Minimum order \$50.

**FREE - VISA/MC!**

1707 S. BASCOM AVE • CAMPBELL, CA 95008 • (408) 559-6555  
1243 W. EL CAMINO • SUNNYVALE, CA 94087 • (415) 965-4494  
1341 FULTON AVE • SACRAMENTO, CA 95825 • (916) 971-3503

**VISIT OUR DISCOUNT SHOWROOMS!**



is now possible to study the structures inside the cells that control shape and thus control the device physics of the cells.

### CREATING EQUIVALENT CIRCUITS

Each of the various nerve-cell components described above has an electrical circuit equivalent. If you combine this electrical equivalent with the submicron three-dimensional geometry of the cell, it is possible to create reasonably accurate models of nerve-cell processing. In what follows I will illustrate the principles used by nerve cells for processing signals by describing the electrical equivalents for a dendrite, the power supply, and the synaptic contact. I will also show how the shape of a cell's processes can alter inputs and outputs and how the cell's internal skeleton can alter process shape. It is also possible to create an equivalent circuit for the axon, but for the sake of simplicity I will limit myself to the passive portions of the nerve cell and will not discuss the electrical properties of the axon.

### THE FORM AND ELECTRICAL CIRCUITS OF THE PASSIVE DENDRITE

Brain-cell dendrites have a skeleton that controls the shape and, to some extent, the branching patterns of the process. As I will discuss below, this skeleton is particularly important in controlling how a brain cell processes information. The dendrite has an outer skin, or membrane, that consists of a very thin layer of oil-like substances called *phospholipids*. Phospholipids have high specific resistivity and capacitance and can be thought of as insulators. The inside of the nerve-cell process is filled with a highly conductive gel, or *axoplasm*, that for our purposes can be thought of as a conducting wire. Thus, a nerve-cell dendrite in the most simple electrical terms is a conducting wire, the axoplasm, with an outer insulating layer, the membrane. The nerve process can be represented with simple electrical equivalents consisting of a ladder network of passive resistors and capacitors.

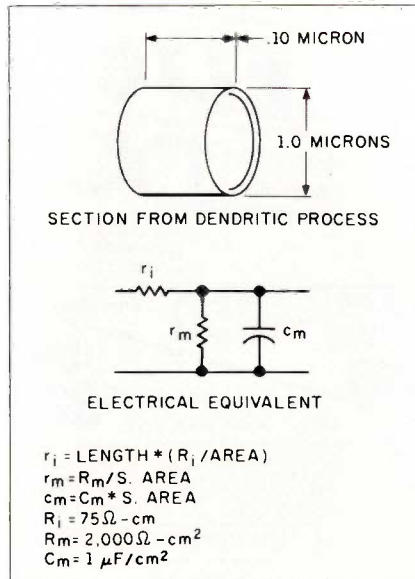

Figure 3: Electrical equivalent of a dendritic circuit. The dendrite segment is about 0.1 micron in diameter.  $S_{area}$  = surface area of the cylinder and  $area$  = cross-sectional area.

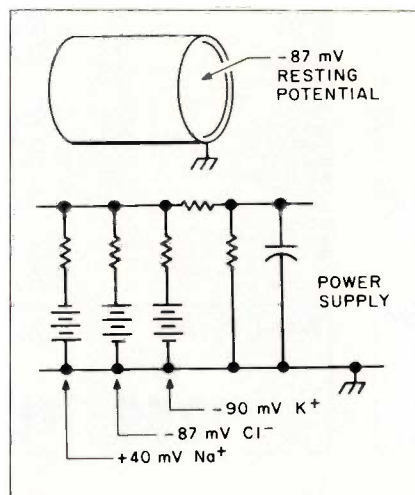

Figure 4: Electrical equivalent of the power supply of a nerve cell. The differences in voltages between this figure and the text reflect normal ranges of cell potentials.

A simple model of a portion of a dendrite is shown in figure 3. Below the model is the equivalent ladder network of resistors and capacitors that represent that model. The resistor labeled  $r_m$  is the resistor used

to represent leakage out of the membrane, while the resistor labeled  $R_i$  is the resistance offered by the internal gel or cytoplasm. Finally,  $c_m$  is the capacitive component of the membrane. These values are calculated from specific resistivities that have been experimentally measured for different cell types and by measuring the detailed geometry of the cell itself. The computation is virtually identical to that now used by IC (integrated-circuit) designers in calculating resistances and capacitances on a chip. IC designers know the specific resistivity of polysilicon, silicon, and metal layers. When given the geometry of a pad, they can compute its total resistance and capacitance.

The specific capacitance of the phospholipids that make up the dendrite's membrane is about 1 microfarad per square centimeter. Thus, we measure the surface area of one small region of the process and multiply it by the specific membrane capacity. The dendritic portion in figure 3 would have a total capacitance of  $1.57 \times 10^{-9}$  microfarad, a membrane resistance of  $1.27 \times 10^{12}$  ohms, and an axial resistance of  $9.55 \times 10^4$  ohms.

### THE NERVE-CELL POWER-SUPPLY CIRCUIT

The power supply for a cell can be represented as a series of batteries in series with a resistor (figure 4). Each battery represents the differential concentration across the cell's membrane of a specific ion. The voltage of the battery for a specific ion is determined directly by its Nernst equilibrium constant, which is given as

$$\text{millivoltage} = 61 \times \log\left(\frac{[OUT]}{[IN]}\right)$$

The concentration of the positively charged ion  $Na^+$  is much higher outside the cell than it is inside the cell by a ratio of about 10:1. Its Nernst equilibrium potential is therefore +61 millivolts (mV). Other ions typically found around cells in warm-blooded animals are  $K^+$ , with a Nernst equilibrium potential of about -90

(continued)

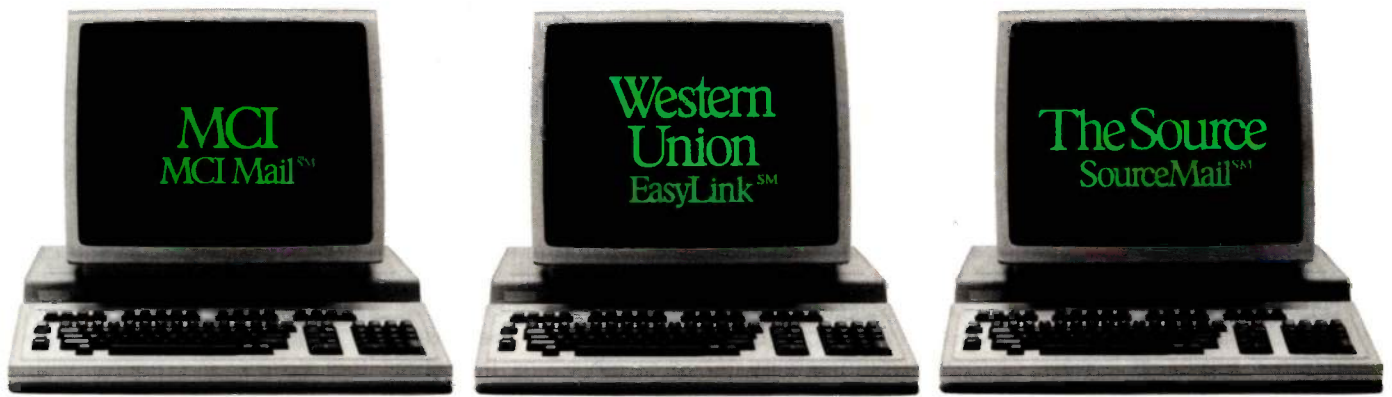

# Which electronic mail service delivers much more than mail?

Every one of these electronic mail services does a very good job of delivering the mail.

But only one delivers so many more online services with equal expertise.

**The Source.**

With The Source, you can have the daily news delivered along with your daily mail. Make airline reservations. Trade stocks. Hold a computer conference. Communicate with thousands of people who share your interests.

Even get the latest word on new hardware and software products, in seconds.

All this, and more, along with the electronic mail service called "the most powerful available anywhere."

And all for just \$49.95,

plus reasonable hourly usage fees.

Call 800-336-3366\* and you can have the power of The Source working for you in a matter of minutes.

Or for more information, visit your nearest computer dealer or mail the coupon below.

Please send me more details about The Source.

Name \_\_\_\_\_ Telephone # \_\_\_\_\_

Address \_\_\_\_\_

City \_\_\_\_\_ State \_\_\_\_\_ Zip \_\_\_\_\_

yes  no I own a personal computer

Mail to: Source Telecomputing Corp.  
1616 Anderson Road  
McLean, VA 22102

7804310

**The Source**<sup>SM</sup>  
INFORMATION NETWORK

The most powerful resource  
any personal computer can have.

The Source is a service mark of Source Telecomputing Corporation, a subsidiary of The Reader's Digest Association, Inc. The source services are offered in participation with Control Data Corporation © Source Telecomputing Corporation, 1985. MCI Mail is a service mark of MCI Communications Corp. EasyLink is a service mark of Western Union.

\*In Virginia or outside the continental U.S. call (703) 821-6666.

## COMMUNICATIONS

SourceMail<sup>SM</sup>  
Mailgram® Message Service  
PARTICIPATE<sup>TM</sup>  
Computer Conferencing  
CHAT Interactive  
Communications

## NEWS & INFORMATION

News Bulletins  
UPI News Service  
Associated Press  
Scripps-Howard News  
Service  
Accu-Weather<sup>TM</sup>  
The Washington Post  
Electronic Edition  
Sports  
BYLINES Feature News

## INVESTOR SERVICES

Portfolio Management  
Delayed Stock Quotes  
Real-Time Stock Quotes  
Spear Securities Online  
Trading  
Media General  
STOCK VUE  
Donoghue Investment  
Newsletter  
INVESTEXT Research  
Reports  
Management Contents  
Publication Abstracts  
Employment Services  
UNISTOX Market Reports  
Commodity World News  
BIZDATE Business  
Magazine

## PERSONAL COMPUTING

MICROSEARCH<sup>TM</sup>  
Hardware, Software  
Reviews  
Member Directory  
POST Bulletin Boards  
Member Publications

## TRAVEL SERVICES

Official Airline Guide  
A-Z Worldwide Hotel Guide  
Travel. Hotel Tickets  
& Reservations  
Restaurant Guides  
Travel Tips. Tours

## SHOPPING & LEISURE

Movie Reviews  
Comp-u-store Electronic  
Shopping  
Games, Educational Quizzes



mV (minus because the concentration of  $K^+$  is greater on the inside of the cell), and  $Cl^-$ , with a potential of  $-87$  mV. The series resistors shown in figure 4 represent leakage of these ions across the membrane to charge the capacitor to its final value. Using special recording methods, it is possible to determine the value of each leakage resistor. Once that is known, we can quickly compute that the potential difference across the membrane will be about  $-87$  mV.

Since this "resting potential" is relatively constant throughout the cell, it is usually not explicitly included in the models or computations. However, the principle of using ionic gradients and membrane resistance to create potential differences is important and will be used below in the description of synapses.

### THE SYNAPSE OR NEURAL GATE CIRCUIT

You might think of synaptic inputs as voltage-controlled changes in the membrane resistor connected to an ionic battery. In some cases the battery may be positive and thus produce a net excitatory change inside the dendrites, and in other cases the battery may be negative and thus produce net inhibition inside the cell. Figure 5 illustrates a schematic synapse making contact with a dendrite. When the voltage inside the

synapse increases, neurotransmitters are released. These neurotransmitters selectively (depending upon their chemical composition) alter the permeability of one or more ions. In effect, these neurotransmitters change the value of the resistor connected to an ionic battery that in turn leads to a change in the resting potential of the cell. A typical gate might have  $5.0 \times 10^{12}$  ohms resting value and  $5.0 \times 10^8$  ohms during activation.

One important point is that a synapse cannot be modeled as a simple voltage input to the dendrite, nor can it be safely represented as a simple injection of current. Rather, it is a complex conductance change within a complex passive RC (resistance-capacitance) network. The final time course and potential seen across the cell's membrane will therefore not be just a function of the synaptic battery and resistor but also of the membrane resistor ( $r_m$ ), axial resistor ( $r_i$ ), and membrane capacitor ( $c_m$ ). Since these components are controlled to some extent by the shape of the cell, the geometry of the cell can be used to control synaptic strength. This principle is illustrated below.

### THE RETINAL AMACRINE CELL ELECTRICAL CIRCUIT

Figure 7 illustrates a retinal amacrine cell, reconstructed by the computer from serial electron micrographs. The

amacrine cell is of particular interest because it has a complex geometry that includes highly irregular and varicose dendrites that attach to the soma. It is a classic interneuron with many synaptic inputs and outputs over the entire cell's surface, and no axon.

Once the surface area and volumes have been computed, the cell is reduced to a simple geometric schematic that approximates the original shape using cylinders similar to those shown in figure 7. You can then easily reduce this schematic to an equivalent circuit by using a membrane resistor, axial resistor, and membrane capacitor to create a large RC ladder network similar to that seen in figure 6. This network can be simulated using conventional linear circuit analysis (see October 1978 BYTE) on almost any small computer.

I have simulated the cell shown in figure 7 using two identical synapses placed on different parts of the cell (A and B in figure 8). I have not included the batteries and resting potential resistors since they would all be equal in this circuit. The synaptic inputs consist of a resistor and a 100-mV battery as shown in figure 5. A synaptic input is modeled as a rapid decrease in the value of the synaptic resistor for 50 ms and then a return to a very high resting value. The lower

(continued)

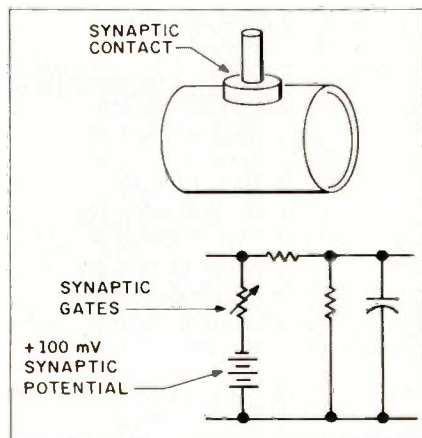

Figure 5: Electrical equivalent of a synaptic gate. We use an arbitrary battery of 100 mV in our models of nerve cells.

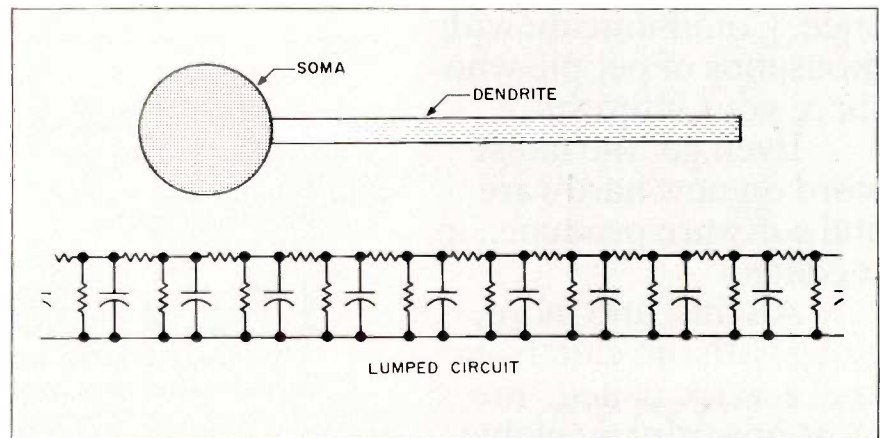

Figure 6: The circuits shown in other figures may be cascaded to create whole cell models.



from MicroComputer Accessories, Inc.

# TOP DRAWER!



Absolutely first class. Our Keyboard Storage Drawer is tops—it can turn your narrow credenza or typewriter return into a perfect work station. From a reinforced platform on protective felt pads, the cantilever drawer extends on industrial strength ball bearing glides and locks into working position. The scratch resistant finish matches IBM colors. Optional locking device. Also available—an under-desktop suspension model—the bottom drawer. But still “top drawer!”

## MicroComputer Accessories, Inc.

5721 Buckingham Parkway  
P.O. Box 3725  
Culver City, California 90231  
Telephone 213/641-1800

In Europe: Inquiry 262 for Dealers.  
Inquiry 263 for End Users.  
N.V. Microcomputer Accessories Europe S.A.  
Rue de Florence 37  
1050 Bruxelles, Belgique  
Telephone 02/538.61.73

These and other fine products are available at Sears Business Systems Centers, Computerland, Businessland, IBM Product Centers and other computer/software retail locations.

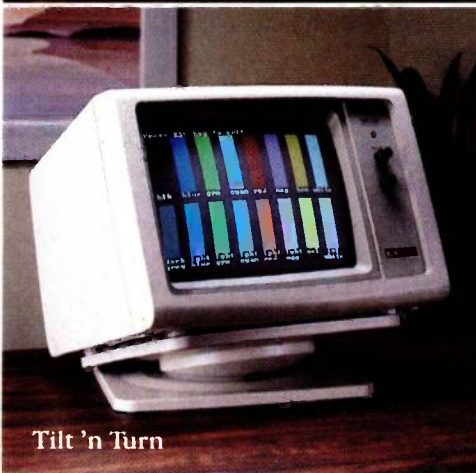

Tilt 'n Turn

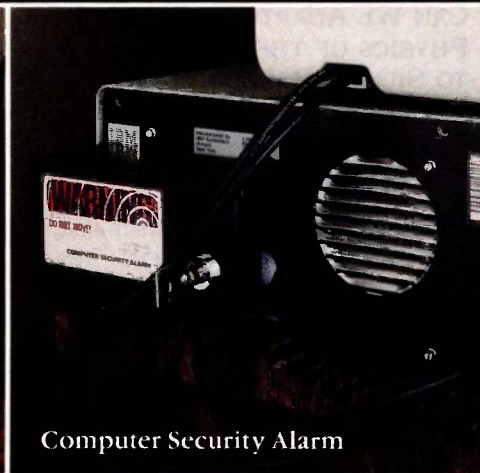

Computer Security Alarm

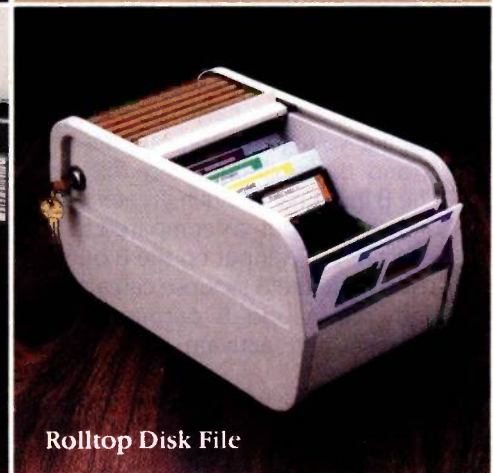

Rolltop Disk File



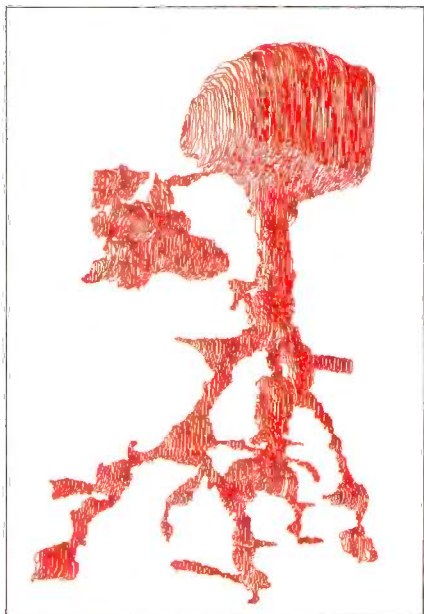

Figure 7: A computer-reconstructed nerve cell from serial electron micrographs similar to those seen in photo 2. The soma diameter is about 10 microns. This amacrine cell from a retinal circuit was reconstructed by R. Jacobs, Playfair, using micrographs collected by B. McGuire.

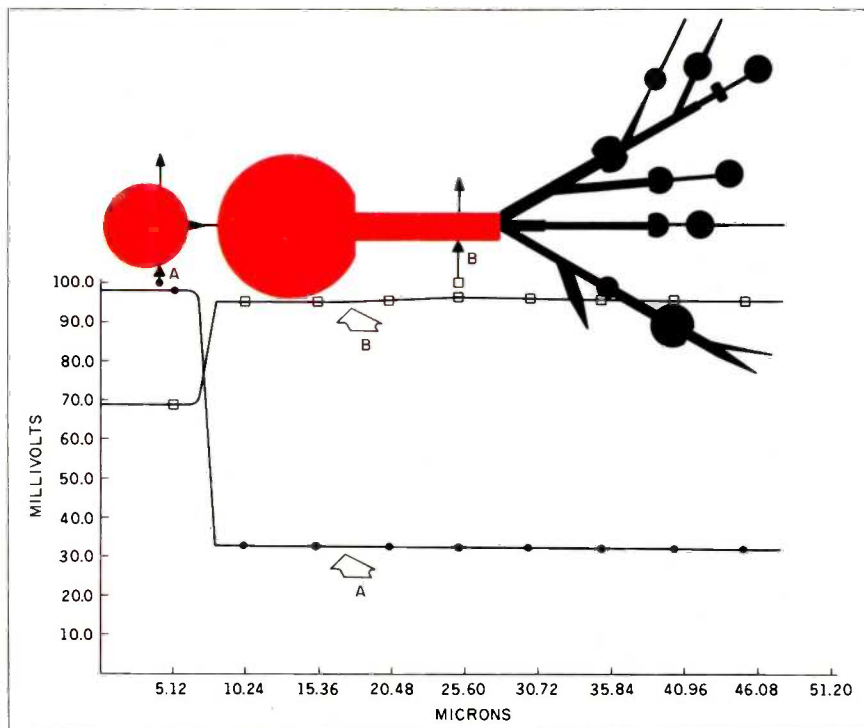

Figure 8: Electrical model of the cell shown in figure 7. Some of the software used to compute these plots was developed by Dr. S. Elias, Massachusetts General Hospital, Harvard Medical School.

part of figure 8 shows the maximum peak of this response inside the cell on the graph. Each line represents the peak voltage along the dark portion of the cell during activation of the synapse.

Since this cell is an interneuron, it does not have an axon (amacrine means "without axon"), nor does it have an action potential. It does, however, have many synaptic outputs to other adjacent cells, two of which are illustrated by large arrows pointing up in figure 8. Keep in mind that the A and B synaptic inputs are identical. Yet the effects they have on the intracellular voltage for the outputs near A and B are dramatically different. The B input has a much greater effect on the A output, as compared to the effect of the A input on the B output. Thus, while the B synapse can activate both the A and B outputs, the A synapse can activate only the A output.

This simple function was created and controlled by geometry of the

nerve cell itself. One can imagine other effects when both synapses are simultaneously activated or when other synaptic inputs are activated farther out on the dendrite. Thus, the specific analog-logical functions of a nerve cell can be controlled by the cell's geometry. This manipulation of cell form can be thought of as the device physics the brain uses to control logical functions.

### CAN WE ADAPT THE DEVICE PHYSICS OF THE BRAIN TO SILICON-BASED CIRCUITS?

The tantalizing question raised by these observations is "Can we adapt this simple principle of changing three-dimensional geometry to silicon-based circuits that could simulate brain circuits?" The answer is "Yes, quite easily." Jack Kilby of Texas Instruments, whose important insight led to the first IC 25 years ago, made us realize that it was possible to control many important silicon-based passive parameters such as the value

of pull-up or pull-down resistors by changing the size and shape of the etched area. While the constants for resistances and capacitances are several orders of magnitude different from brain constants, it is interesting that the circuits in figures 3 and 6 are exact equivalents of those used to simulate an interconnection within a silicon chip. The equations and software used to simulate the nerve cell above are almost identical to the software used to simulate a full IC during design.

Projects to create these silicon-based neurons, called *silicrons*, are just now getting under way. Conceptually, the shape of the cell is simply etched into silicon in place of the conventional linear interconnections. Gates are placed at locations where synaptic inputs and outputs might be located, and for output silicrons we can simulate an axon with a simple Schmitt trigger circuit or one-shot.

Unfortunately, silicrons will be only

(continued)

**YOUR DAYS OF  
BUYING TERMINALS  
ARE OVER!**

Now there's SmarTerm terminal emulation software for your IBM\* PC, XT, AT or compatible system. All SmarTerm products offer comprehensive and exact terminal emulation, powerful ASCII and binary file transfer facilities, and include TTY mode to link you to The Source, CompuServe, Dow Jones, Easylink, Tymnet or other popular services.

We've included features such as multiple setup configurations, XMODEM and PDIP\* protocol

support, "smart" softkeys, plus European DOS support.

**SmarTerm 100** is your choice for DEC\* VT100, VT102 and VT52 emulation.

**SmarTerm 125** has all the features of SmarTerm 100, plus VT125 ReGIS graphics support. For Data General Dasher\* D100, D200 or D400 emulation, you need **SmarTerm 400**.

More than 20,000 users have already "flocked" to SmarTerm. Try it for 30 days, with full refund privileges, and you will be sold too.

Persoft, Inc. - 2740 Ski Lane  
Madison, WI 53713  
(608) 273-6000 - TELEX 759491



# **AFTER SMARTERM™, DO YOU DO WITH YOUR OBSOLETE TERMINAL?**



**IDEA CREDIT: The University of Wisconsin Zoological Museum.** See your name in print! The best ideas for uses of obsolete terminals replaced by SmarTerm will be used in future ads. Write Persoft, Dept. BIRDIE., 2740 Ski Lane, Madison, WI 53713.

\*SMARTERM and PDIP are trademarks of Persoft, Inc. \* IBM is a registered trademark of International Business Machines Corp. \* DEC, VT and ReGIS are trademarks of Digital Equipment Corp. \* DASHER is a registered trademark of Data General Corp.  
© Persoft, Inc. 1984. All rights reserved.

See us at SOFTCON, booth #2011





# STATGRAPHICS.<sup>®</sup> ONE KEYSTROKE TURNS LIFELESS DATA...

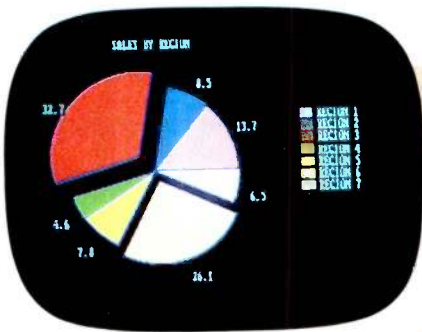

Date Updated: 03/01/85 Data Editor Maximum Rows: 166 Number of Cols: 9

Row	X	Y	samples	samples	shipments	sales
1	43.1	1865	1	18.1	2,815	42200
2	38.1	1800	1	18.2	2,612	22000
3	25.9	1805	1	18.8	2,725	94600
4	38.4	2070	1	18.0	2,721	1,1870
5	38.1	1800	2	18.1	2,348	19425
6	19.9	3305	2	18.2	3,026	66000
7	19.4	3735	2	18.4	2,282	16250
8	20.2	3570	2	18.0	2,212	27500
9	18.2	3532	2	18.1	2,922	31500
10	20.5	3155	2	18.2	4,301	78900
11	20.2	2865	3	18.0	5,284	12950
12	25.1	2720	3	18.1	7,312	22750
13	20.5	3430	3	18.7	2,541	8750
14	18.1	3210	3	18.3	2,475	15000

Length: 150 150 100 100 64 25  
Type: N N N N N N  
Cursor at Row: 1 Col: Column 1  
\*HELP 2SAVE 3DONE 4SORT 5DSORT 6VSORT 7OVSORT 8UNSORT 9PRINT 10QUIT  
INPUT FRH MAR 1 1985 02:58:00 PM VERSION 1.0 REC: 01 F

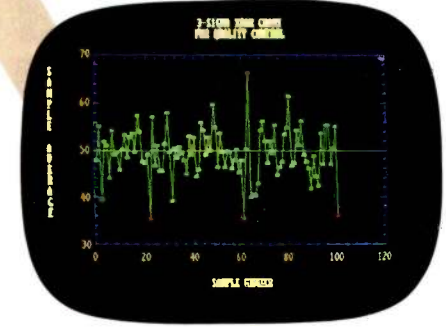
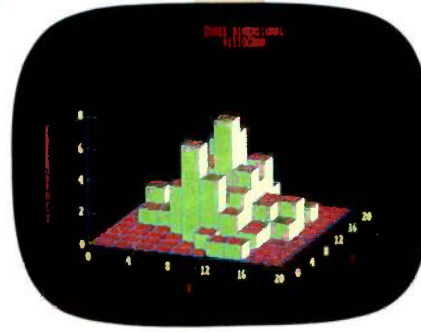
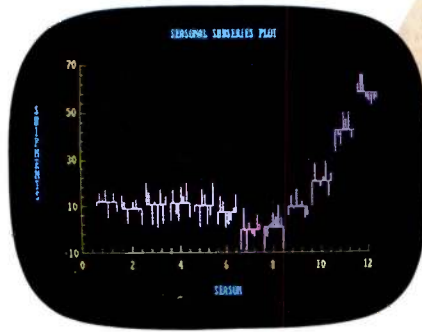
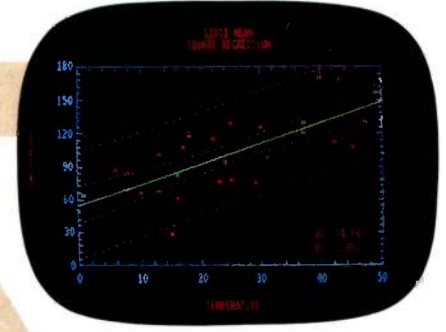

## INTO VITAL STATISTICS.

Data. You live with it every day. What you need are the tools to make it come alive. Comprehensive analytical tools. Mathematical precision. And graphics capabilities to broaden your insights — to help you visualize, analyze, and communicate your findings quickly and convincingly.

And now you've got it. With STATGRAPHICS — a new PLUS\*WARE™ product from STSC. STATGRAPHICS is the only PC software to fully integrate a wide variety of statistical functions with high-resolution color graphics. Giving you the power and precision you used to find only with mainframe software.

STATGRAPHICS' unique interactive environment allows you to generate graphs from within the statistical procedures. You can change a variable and see the effect — immediately. So your job is easier and you're more productive.

### MORE OPTIONS FOR MORE COMPREHENSIVE ANALYSIS.

STATGRAPHICS features over 250 functions for analyzing data — including analysis of variance, regression analysis, experimental design, quality control procedures, multivariate techniques, nonparametric methods, and extensive forecasting and time series analysis.

It also lets you enter data at the keyboard or access data stored in standard ASCII files, LOTUS® 1-2-3 worksheets, and DIF files used by other popular software packages.

### TELL A CLEARER, MORE DRAMATIC STORY.

STATGRAPHICS includes a wide variety of graphics programs such as two and three-dimensional line and surface plots, bar and pie charts, histograms, time sequence plots, and quality control charts.

The graphics are supported on color and monochrome graphics boards, dot-matrix printers, and pen plotters for presentation quality graphics.

### SOPHISTICATED STATGRAPHICS IS SURPRISINGLY SIMPLE TO USE.

STATGRAPHICS is completely menu-driven, and includes a comprehensive user's guide, online HELP screens, tutorial, and handy reference card. And STSC's HELP-Line is only a phone call away — giving you ready access to our staff of technical experts.

### TAKE A LOOK AT STATGRAPHICS. AND LOOK NO FURTHER.

STATGRAPHICS is the most advanced statistical graphics software available for PC's. And the complete system is just \$695.

To order STATGRAPHICS, or for more information, contact your local dealer or call 800-592-0050 (in Maryland, 301-984-5123). Or write STSC, Inc., 2115 E. Jefferson St., Rockville, MD 20852. Major credit cards accepted.

Inquiry 368

**Problem-solving at the speed of thought.**

**STSC**  
A Contel Company

STATGRAPHICS operates on IBM PC's and compatibles under DOS, Version 2.0 or later. A minimum of 384K RAM, a graphics adapter and compatible monitor, and two double-sided disk drives or a hard disk are required. An 8087 math coprocessor and 512K RAM are recommended. STATGRAPHICS is a registered trademark of Statistical Graphics Corporation. PLUS\*WARE is a trademark of STSC, Inc. LOTUS is a registered trademark of Lotus Development Corporation.

THE BRAIN

a laboratory curiosity until one final problem has been resolved—how do we create new and arbitrary programs? There is no simple way to change or modify the strength of connections from one silicon to another. Since researchers do not really have a clear understanding of how the brain modifies its own circuits (the device physics of learning), any silicon-based solutions will be non-biological. Ongoing biological work is encouraging and suggests that in some cells active shape change of dendrites may lead to changes in synaptic strength. Nevertheless, it is safe to say that it will be some time before we will have a full understanding of perhaps the most impressive feature of neural circuits: their ability to program themselves. In the meantime, it will certainly be possible to create very fast neuronlike devices with well-defined, prewired functions such as CCD (charge-coupled device) image processing. However, it will be quite some time before we can create what could legitimately be called a sixth-generation computer based on a neurological model. ■

The micrograph of brain cells grown in tissue culture by Judy Trogadis (see page 286) is available as a museum-quality poster for \$7 (U.S.) plus \$3 for postage and handling. Phone (713) 664-7457 or 526-9617 or write Synaptic Poster, 8 Alexander St., Brampton, Ontario L6V 1H6, Canada (VISA and MasterCard accepted). All proceeds from the sale of the poster will support the research described in this article. Copyright 1983, 1985. J. Trogadis and J. Stevens.

BIBLIOGRAPHY

1. Kuffler, S. W., and John Nicholls. *From Neuron to Brain*. Sunderland, MA: Sinauer Associates Inc., 1976.
2. Mead, C., and L. Conway. *Introduction to VLSI Systems*. Reading, MA: Addison-Wesley, 1980.
3. Stevens, J., and J. Trogadis. "Computer-Assisted Reconstruction from Serial Electron Micrographs," in *Advances in Cellular Neurobiology*, Vol. 5, pages 341-369, Ed. S. Fedoroff. Orlando, FL: Academic Press, 1980.

# INSIGHT™

## EXPERT SYSTEMS

**"INSIGHT is essentially the equivalent or better than any other tool available for the personal computer."**

*Paul Harmon, author of Expert Systems, Artificial Intelligence in Business*

Turn your PC into an expert.

**Give it Insight, or give it Insight 2.** Both let you create knowledge base systems using any PC-compatible text editor.

**Insight** not only simplifies access to lots of information, it analyzes and offers solutions. For entry-level operators it's a perfect procedural training package to help build and implement knowledge base software.

**Insight 2** is more than just an "expert." It's a knowledge base engineering tool with application capabilities. It can call up Pascal programs, read and write dBASE II® files, and its decision-making process can tie in directly to your existing databases. Run-only versions also can be developed and distributed.

**Two unique packages from the same expert idea.**



**Level Five Research, Inc.**

*Insight™ (\$95) and Insight 2™ (\$485) run on the IBM® PC, DEC® Rainbow, and Victor® 9000.*

4980 South A-1-A

Melbourne Beach, Florida 32951

(305) 729-9046

# POSTURE SUPPORT THE BACK CHAIR

**NOW ON SALE FROM \$29.95**



The ORIGINAL Genuine Oak Chair SALE PRICE: \$29.95!

New 3-Position Adjustable Chair ON WHEELS: \$49.95.

The First "Intelligent" Chair, FORMERLY \$89.95! Now on sale from **\$29.95. REDUCE THE EFFECT OF GRAVITY ON YOUR BACK.** Sitting regularly in a conventional chair your lower back is supporting the **TOTAL WEIGHT** of your body, plus additional weight due to the downward effect of gravity. Unfortunately most chairs are designed for appearance, not for comfort.

**THE BACK CHAIR SOLUTION**—Sitting on the Back Chair relieves your back from supporting the total weight of your body by distributing your weight between your lower back and legs. Your legs support you when standing, your lower back supports you when sitting. Combine them both in a comfortable sitting posture and you relieve the unnecessary stress on your back. When sitting on the Back Chair you'll feel more relaxed and sit up perfectly straight.

Standard Chair made of hardwood layers with final layer of Genuine Oak. Adjustable Chair made from solid hardwood with beautiful Oak Finish. Both come with **padded seat and knee pads** upholstered in Chocolate Brown. Dealer and Rep Inquiries Invited.

**SHOP FASTER BY PHONE 1-805-966-7187**

Or send a check or your credit card # (Diner's Club, VISA, MasterCard, American Express) for THE BACK CHAIR (Standard Model, \$29.95 ea., Adjustable Model, \$49.95 ea.—please indicate below) plus \$9.95 shipping (Canadian orders, \$13.00 shipping). CA residents add 6% sales tax. Sorry no C.O.D. If not satisfied return within 15 days for refund (less shipping).

ITEM NO.	QUAN.	ITEM	PRICE EA.	SHIPPING	TOTAL
825		Stand. BACK CHAIR	\$29.95		
808		Adj. BACK CHAIR	\$49.95		

**STARSHINE GROUP**  
816 B State Street, Dept. BC310, Santa Barbara, CA 93101  
America's Premium Direct Mail House Now In Our 9th Year



# IT ALL ADDS UP...

## IBM SYSTEMS

Starting as low as  
**\$1599**

**256K, 1-DS/DD DRIVE  
KEYBOARD**



## MULTIFUNCTION CARDS

### IDEA

IDEAmax - ZPR, 64K, C, S, P \$229.00  
IDEAmini - YPR, C, S, P \$189.00  
IDEAminimax - MPR 128K \$229.00  
IDEAshare Software \$219.00

### QUADRAM

Quadboard \$229.00  
Quadboard II \$229.00  
Expanded Quadboard \$239.00  
Quad 512+ \$249.00  
Quad 2 Meg. \$879.00  
Memory Board \$229.00  
Quad Jr Exp. Chassis \$539.00  
Quad Jr Exp. Memory \$219.00  
QuadMem Jr \$229.00  
Chronograph \$89.99  
Parallel Card \$69.99

### AST

Six Pack Plus \$239.00  
Mega Plus II \$269.00  
I/O Plus II \$139.00  
Memory MBII \$249.00  
Advantage-AT \$399.00

### TECMAR

Captain 64 \$239.00  
Captain Jr. 128K \$339.00

### PARADISE

Five Pack - C, S, P \$189.00

## VIDEO CARDS

Amdek - MAI \$249.00  
AST - Preview Monograph \$299.00  
Graph Pak Mono/64K \$599.00  
MonoGraph Plus \$399.00  
Hercules - Graphics \$349.00  
Color \$199.00  
Paradise - Modular Graphics \$319.00  
Multi-Display \$299.00  
Eagle - Color \$199.00  
Quadram - Quadcolor I \$219.00  
Quadgraph \$379.00

## MAINFRAME

AST 5251/11 CALL  
5251 \$579.00  
3780 \$639.00  
BSC \$499.00  
DCA IRMA 3270 \$899.00

## KEYBOARDS

Keytronics Keyboards 5150, 5151,  
5151 Jr, 5149 Jr. CALL

## MEMORY CHIPS

4164 RAM Chips. ea. \$2.99

## HARD DRIVES

Alloy CALL  
IDEAssociates - 5, 10, 15, 20, 25, 40  
and 45 meg. from \$1299.00  
Iomega 10, 20 meg. from \$2149.00  
TallGrass 20,30,80 meg from \$2699.00  
Tandon 5 1/4" 320K Floppy \$139.00

## SOFTWARE

### LOTUS

Symphony \$449.00  
1-2-3 \$309.00

### Hayes

Please (Data Base) \$239.00

### PEACHTREE SOFTWARE

PeachPack (GLA/PAR) \$219.00

### MICROPRO

WordStar 2000 \$279.00

### MICROMIM

R:Base 4000 \$279.00

### MULTIMATE INT.

Multi Mate \$269.00

### MICROSTUF

Crosstalk \$99.99

### MICROSOFT

Flight Simulator \$39.99

MultiPlan \$139.00

### ASHTON-TATE

Framework \$349.00  
dBASE II \$299.00  
dBASE III \$389.00  
dBASE II upgrade \$139.00  
Friday! \$179.00

### PROFESSIONAL SOFTWARE

PC Plus/The Boss \$269.00

### SYNAPSE

File Manager \$59.99

### ELECTRONIC ARTS

Get Organized \$79.99  
Cut -n- Paste \$39.99  
Music Construction \$29.99  
One -on- One \$29.99  
Financial Cookbook \$34.99

### ALPHA SOFTWARE

Electronic Desk \$219.00

### BORLAND

Turbo Pascal \$39.99  
Sidekick \$39.99

### SPI

Open Access \$399.00

### HARVARD SOFTWARE INC.

Harvard Project Manager \$229.00

### PFS

### IBM/APPLE

Access (NEW) \$89.99  
Write \$89.99  
Graph \$89.99  
Report \$79.99  
File \$89.99  
Plan \$89.99

### HUMAN EDGE SOFTWARE

Communication Edge \$129.00  
Management Edge \$165.00  
Negotiation Edge \$195.00  
Sales Edge \$165.00

## PC COMPATIBLES



**ZENITH**  
MBC 580 \$639.00  
MBC 580-2 \$749.00  
MBC 585 \$879.00  
MBC 585-2 \$1099.00  
MBC 775 Portable CALL  
CORONA  
Desktops CALL  
Portables CALL

### COLUMBIA

Desktops CALL  
Portables CALL

## APPLE

**APPLE IIe PROFESSIONAL PACK** APPLE IIe CALL  
64K Apple IIe, Dual Disk Drive & Controller, Extended 80 Column Card, MacINTOSH CALL  
Monitor II & DOS 3.3 CALL  
Apple IIc LCD Display CALL

## MONITORS

**AMDEK**  
300 Green \$129.00  
300 Amber \$149.00  
300 Color/Audio \$259.00  
310 Amber IBM-Plug \$169.00  
Color 500 Composite/RGB/VCR \$389.00  
Color 600 Hi-Res (640 x 240) \$439.00  
Color 700 Hi-Res (720 x 240) \$499.00  
Color 710 Long Phosphor \$579.00  
**BMC**  
1201 Plus (12" Green Hi-Res) \$88.99  
9191U Color \$209.00  
9191 Color Plus \$229.00  
**NAP**  
12" Amber \$69.99  
**NEC**  
JB 1260 Green \$99.99  
JB 1201 Green \$139.00  
JB 1205 Amber \$149.00  
JB 1215 Color \$229.00  
JC 1216 RGB \$379.00  
JC 1460 Color \$269.00  
**PRINCETON GRAPHICS**  
MAX-12 Amber \$199.00  
HX-12 RGB \$489.00  
SR-12 RGB \$629.00

**SAKATA**  
SC-100 Color \$249.00  
SG-1000 Green \$129.00  
SA-1000 Amber \$139.00  
**TAXAN**  
115 12" Green Mono \$99.99  
116 12" Amber Mono \$99.99  
121 Green TTL \$149.00  
122 Amber TTL \$159.00  
210 Color RGB \$239.00  
400 Med-Res RGB \$319.00  
415 Hi-Res RGB \$439.00  
420 Hi-Res RGB (IBM) \$429.00  
440 Ultra Hi-Res RGB \$649.00  
**QUADRAM**  
8400 Quadchrome \$489.00  
8410 Quadchrome II \$479.00  
8420 Amberchrome \$199.00  
**ZENITH**  
ZVM 122 Amber \$84.99  
ZVM 123 Green \$84.99  
ZVM 124-IBM Amber \$149.00  
ZVM 131 Color \$309.00  
ZVM 133 RGB \$429.00  
ZVM 135-RGB/Color \$459.00  
ZVM 136-RGB/Color \$629.00

## MODEMS

**ANCHOR**  
Volksmodem \$59.99  
Volksmodem XII \$189.99  
Mark II Serial \$79.99  
Mark VII (Auto Ans/Auto Dial) \$99.99  
Mark XII (1200 Baud) \$259.00  
**Hayes**  
Smartmodem 300 \$199.00  
Smartmodem 1200 \$419.00  
Smartmodem 1200B \$389.00  
Smartmodem 2400 \$699.00  
Micromodem IIe \$269.00  
Micromodem 100 \$149.00  
Smart Com II \$89.99  
Chronograph \$199.00

**AST**  
Reach 1200 Baud Half Card \$399.00  
**Novation**  
Smart Cat Plus \$329.00  
J-Cat \$199.99  
Smart Cat 103 \$179.00  
Smart Cat 103/212 \$399.00  
AutoCat \$219.00  
212 AutoCat \$549.00  
Apple Cat II \$249.00  
212 Apple Cat \$449.00  
Apple Cat 212 Upgrade \$259.00  
**ZENITH**  
ZT-1 \$339.00  
ZT-10 \$309.00  
ZT-11 \$369.00



# COMPUTER MAIL ORDER

TOLL FREE ORDER LINE **1-800-233-8950**

In PA Call: (717) 327-9575

### WEST

P.O. Box 6689, Dept. A104  
Stateline, NV 89449

### EAST

477 E. 3rd St., Dept. A104  
Williamsport, PA 17701

Order Status Number: (717) 327-9576

Customer Service Number: (717) 327-1450

### CANADIAN ORDERS

Ontario/Quebec: **1-800-268-3974**  
Other Provinces: **1-800-268-4559**  
In Toronto: (416) 828-0866 Telex: 06-218960  
2505 Dunwin Drive, Unit 3  
Mississauga, Ontario, Canada L5L1T1



# ...THE BEST PRICES



## PRINTERS

<b>AXIOM</b>		<b>NEC</b>	
AT-100 Atari Interface Printer	\$159.00	8027 Transportable	\$329.00
AT-550 Atari Dual Mode	\$259.00	2010/15/30	\$719.00
GP-100 Parallel Interface	\$189.00	2050 IBM	\$639.00
GP-700 Atari Color Printer	\$489.00	3510/15/30	\$1299.00
GP-550 Parallel Printer	\$269.00	3550 IBM	\$1399.00
<b>BMC</b>		8810/15/30	
401 Letter Quality	\$589.00	8850 IBM	\$1749.00
BX-80 Dot Matrix	\$229.00	<b>OKIDATA</b>	
<b>CITIZEN</b>		82, 83, 84, 92, 93, 180,	
MSP-10 (80 col)	\$349.00	2350, 2410, Okimate-20.....CALL	
MSP-15 (132 col)	\$539.00	Okimate-64.....\$199.00	
<b>CITOH</b>		Okimate - Atari.....\$199.00	
Prowriter 7500	\$289.00	<b>OLYMPIA</b>	
Prowriter 8510P	\$339.00	Needlepoint Dot Matrix.....\$339.00	
Prowriter 1550P	\$569.00	Compact R0.....\$399.00	
Son of Starwriter A10P	\$479.00	Compact 2.....\$439.00	
Hot Dot Matrix	CALL	<b>PANASONIC</b>	
F10-40P Starwriter	\$949.00	KX1090.....\$219.00	
F10-55 Printmaster	\$1099.00	KX1091.....\$299.00	
<b>COMREX</b>		KX1092.....\$449.00	
ComWriterII Letter Quality	\$399.00	KX1093.....\$639.00	
<b>DIABLO</b>		<b>QUADRAM</b>	
620 Letter Quality	\$749.00	Quadjet.....\$749.00	
630 API Letter Quality	\$1549.00	<b>SILVER REED</b>	
<b>DAISYWRITER</b>		400 Letter Quality.....\$279.00	
2000	\$949.00	500 Letter Quality.....\$329.00	
<b>EPSON</b>		550 Letter Quality.....\$459.00	
RX-80, RX-80FT+, RX-100.....CALL		770 Letter Quality.....\$799.00	
FX-80+, FX-100+, LX-80.....CALL		<b>STAR MICRONICS</b>	
LQ 1500, JX80 Color.....CALL		SG10 (120 cps).....\$499.00	
<b>JUKI</b>		SG15 (120 cps).....\$219.00	
6100.....\$439.00		SD10 (160 cps).....\$379.00	
6300.....\$749.00		SD16 (160 cps).....\$499.00	
<b>MANNESMAN TALLY</b>		SR10 (200 cps).....\$529.00	
Spirit 80.....\$239.00		SR15 (200 cps).....\$669.00	
160L.....\$569.00		Powertype.....\$329.00	
180L.....\$699.00		<b>TOSHIBA</b>	

## INTERFACES

<b>PRACTICAL PERIPHERALS</b>		<b>ORANGE MICRO</b>	
Graphcard	\$84.99	Grappler CD (C64).....\$99.99	
Seriall Card	\$109.00	Grappler + (Apple).....\$109.00	
Microbuffer II +	\$179.00	Grappler 16K + (Apple).....\$189.00	
Microbuffer 32K	\$199.00	<b>DIGITAL DEVICES</b>	
<b>QUADRAM</b>		Ape Face (Atari).....\$49.99	
Microfazer	from \$139.00	Uprint (Atari).....\$59.99	
Efazer (Epson)	from \$79.99	Uprint (C-64).....\$59.99	
<b>MICROBITS</b>		Printer Buffer P-16.....\$79.99	
MB1150 (Atari)	\$79.99		



<b>HEWLETT PACKARD</b>	
41CV	\$189.99
41CX	\$249.99
HP 71B	\$419.99
HP 11C	\$62.99
HP 12C	\$89.99
HP 15C	\$89.99
HP 16C	\$89.99
HP 75D	\$999.99
HPIL Module	\$98.99
HPIL Cassette or Printer	\$359.99
Card Reader	\$143.99
Extended Function Module	\$63.99
Time Module	\$63.99
We stock the full line of HP calculator products	

<b>NEC</b>	
PC-8401	CALL
PC-8201 Portable Computer	\$299.00
PC-8231 Disk Drive	\$619.00
PC-8221A Thermal Printers	\$149.00
PC-8281A Data Recorder	\$99.99
PC-8201-06 8K RAM Chips	\$105.00
<b>SHARP</b>	
PC-1350	\$159.99
PC-1261	\$159.99
PC-1260	\$109.99
PC-1800A	\$168.99
PC-1250A	\$88.99
CE-125 Printer/Cassette	\$128.99
CE-150 Color Printer Cassette	\$171.99
CE-161 16K RAM	\$134.99

## ATARI

## HOME COMPUTERS

NEW

65XE (64K)  
130XE (128K)  
130ST (128K)  
520ST (512K)

CALL FOR PRICING

600XL & 800XL CALL WHILE SUPPLIES LAST

850 Interface	\$109.00	CX30 Paddles	\$11.99
1010 Recorder	\$49.99	CX40 Joystick	\$7.99
1020 Color Printer	\$79.99	4011 Star Raiders	\$12.99
1025 Dot Matrix Printer	\$199.99	4022 PacMan	\$16.99
1027 Letter Quality Printer	\$269.99	4025 Defender	\$32.99
1030 Direct Connect Modem	\$69.99	8026 Dig Dug	\$32.99
1050 Disk Drive	\$179.99	8031 Donkey Kong	\$32.99
Touch Tablet	\$64.99	8034 Pole Position	\$32.99
7097 Atari Logo	\$74.99	8043 Ms PacMan	\$32.99
4018 Pilot (Home)	\$57.99	8044 Joust	\$32.99
5049 VisiCalc	\$59.99	8052 Moon Patrol	\$32.99

## MEMORY BOARDS

Axlion 32K	\$39.99
Axlion 48K	\$69.99
Axlion 128K	\$269.99
Microbits 64K (600)	\$109.00
<b>SWP</b>	
ATR-8000-16K Z80 CPM	\$349.00
ATR-8000-64K Z80 CPM	\$499.00
<b>BIT 3</b>	
Full View 80	\$239.00

## DISK DRIVES

<b>INDUS</b>	
GT Drive (Atari)	\$259.00
<b>RAWA</b>	
Rana 1000	\$199.00
<b>MODEMS</b>	
Micro Bits MB-1100	\$129.99

## COMMODORE

<b>NEW Commodore 128, LCD.....CALL</b>	
CBM 8032	\$639.00
CBM 4032	\$599.00
CBM 9000	\$999.00
2031 LP Disk Drive	\$299.00
8050 Disk Drive	\$999.00
8250 Disk Drive	\$1249.00
4023 Printer	\$329.00
8023 Printer	\$589.00
6400 Printer	\$1349.00
Z-RAM	\$299.00
Silicon Office	\$299.00
<b>SI-64 Portable.....\$499.00</b>	
<b>Commodore Plus 4.....\$199.00</b>	
<b>CBM 64.....\$149.00</b>	
C1541 Disk Drive	\$199.00
C1530 Datasette	\$39.99
M-801 Dot Matrix Printer	\$189.00
M-802 Dot Matrix/Serial	\$219.00
MCS 803 Dot Matrix	\$179.00
C1802 Color Monitor	\$199.00
C1660 Auto Modem	\$89.99
DPS 1101 Daisy Printer	\$339.00

## PROFESSIONAL SOFTWARE

Word Pro 4 Plus/5 Plus each	\$239.00
Info Pro	\$179.00
Administrator	\$399.00
Power	\$69.99



SD1 Disk Drive	\$299.00
SD2 Disk Drive	\$529.00



Indus GTC64	\$269.00
-------------	----------

## maxell. DISKETTES

5 1/4" MD-1	\$18.99	Elephant 5 1/4" SS/SD	\$14.99
5 1/4" MD-2	\$28.99	Elephant 5 1/4" SS/DD	\$16.99
8" FD-1	\$39.99	Elephant 5 1/4" DS/DD	\$20.99
8" FD-2	\$49.99	Elephant EMSF 5 1/4"	\$29.99

## VERBATIM

5 1/4" SS/DD	\$21.99
5 1/4" DS/DD	\$29.99

## BIB

5 1/4" Disk Head Cleaner	\$14.99
--------------------------	---------

## DISK HOLDERS

<b>INNOVATIVE CONCEPTS</b>	
Flip-in-File 10	\$3.99
Flip-in-File 50	\$17.99
Flip-in-File 50 w/lock	\$24.99
Flip-in-File (400/800 ROM)	\$17.99

# COMPUTER MAIL ORDER



TOLL FREE ORDER LINE **1-800-233-8950**

In PA Call: (717) 327-9575



## CANADIAN ORDERS

Ontario/Quebec: **1-800-268-3974**

Other Provinces: **1-800-268-4559**

In Toronto: (416) 828-0866 Tele: 06-218960

2505 Dunwin Drive, Unit 3

Mississauga, Ontario, Canada L5L1T1



Order Status Number: (717) 327-9576

Customer Service Number: (717) 327-1450

CANADIAN ORDERS: All prices are subject to shipping, tax and currency fluctuations. Call for exact pricing in Canada. INTERNATIONAL ORDERS: All orders placed with U.S. offices for delivery outside the Continental United States must be pre-paid by certified check only. Include 3% (minimum \$5) shipping and handling. EDUCATIONAL DISCOUNTS: Additional discounts are available to qualified Educational Institutions. APO & FPO: Add 3% (minimum \$5) shipping and handling.



**ORDER  
LINE  
800-354-7330**

# SILICON SPECIALTIES

## PRINTERS

### Anadex

9825B \$1129  
WP6000 \$2039  
DP6500 \$2259

### Brother

DX-15 \$355  
DX-15XL \$365  
HR-25 \$649  
HR-35 \$875

### C-Itoh

A-10-30 \$459  
F-10 Parallel or Serial \$859  
55 CPS Serial or Parallel \$1019  
8510 Parallel (Prowriter) \$299  
8510 SP \$385  
8510 SCP \$459  
8510 BPI \$309

### Comrex

CR-2E Parallel \$375  
CR-4 Call  
420 Call

### Datasouth

DS180 \$1089  
DS220 \$1315

### Diablo

620 \$694  
630 API \$1499  
630 ECS \$1669  
630 ECS/IBM \$1669  
Series 36 \$1139  
801F \$2649  
P12CQI \$529  
P32CQI \$759  
S32CQI \$839  
P38 \$1639  
S38 \$1719  
C150 \$999

### Epson All Printer Models

Call Save

### Inforunner

RiteMan w/Tractor \$244  
RiteMan 15 \$499  
RiteMan Blue w/Tractor \$299

### Juki

5500 Call  
6100 \$385  
6300 \$699

### NEC

2010, 2015, 2030 \$639  
2050 \$669  
3510, 3515, 3530 \$1215  
3550 \$1359  
8810, 8815, 8830 \$1665  
8850 \$1779  
P2, P3 Call

### Okidata All Printer Models

Call

### Panasonic

1091 \$265  
1092 \$395  
1093 \$595  
KXP3151 \$459

### Silver Reed

EXP400 \$235  
EXP500 Parallel or Serial \$289  
EXP550 Parallel or Serial \$399  
EXP770 Parallel or Serial \$689

### Star Micronics

All Printer Models Save

### Tally

Spirit 80 \$245

### Toshiba

P1340 Parallel or Serial \$665  
P1351 Parallel or Serial \$1165

## MODEMS

### Anchor Automation

Anchor Express Save  
Mark XII \$239

### Hayes

Smartmodem 300 Baud \$190  
Smartmodem 1200 Baud \$455  
Smartmodem 1200B (IBM) \$385  
Micromodem IIE (Apple) \$219

### Novation

Smart Cat Plus \$315

### Prometheus All models

Save

### Racal-Vadic All Models

Call

### US Robotics Password 1200

\$219

## MONITORS

### Amdek All Monitors

Call

### Princeton Graphic

HX-12 \$479

### Sanyo

CRT-30 \$599  
CRT-36 \$149  
CRT-50 Call  
CRT-70 \$549

### Taxan

121 Green \$125  
122 Amber \$134  
420 RGB \$399  
425 RGB/Green \$410

### Zenith

ZVM-122 Amber \$95  
ZVM-123 Green \$95  
ZVM-124 \$129  
ZVM-130 Save  
ZVM-133 Color/RGB \$410  
ZVM-135 Color/RGB W/Audio \$459  
ZVM136 \$575

## KEYBOARDS

### Keytronics

S15 \$179  
S151 Jr. \$179

## PLOTTERS

### Enter

Sweet-P600 \$780

## COMPUTERS

### Altos All Computer Models

Call

### Columbia

Call

### NEC

PC-8201 Computer \$315  
PC-8201A-90 Battery Pack \$15  
PC-8206A 32K Ram \$215  
PC-8271A-01 AC Adapter \$16  
PC-8271A-02 AC Adapter \$16  
PC-8281A Recorder \$89

### Northstar

All Computer Models Call

### Sanyo MBC-775 Portable

MBC-550 System Call  
MBC-555 System Call  
MBC-550-2 System Call  
MBC-555-2 System Call  
MBC-885 Call

### Televideo

803 \$1915  
804 \$3429  
1605D \$1909  
1605C \$2299  
1605H \$3459  
1605CH \$3549  
TPC-1 \$755  
TPC-2 Single Drive \$1509  
TPC-2 Dual Drive \$1749

### Visual

Commuter From \$1469

### Zenith

Z-150 Single Drive Save 25%  
Z-150 Dual Drive Save 25%  
Z-150 W/10 Megabyte Save 25%  
Z-160 Single Drive Save 25%  
Z-160 Dual Drive Save 25%

## DISK DRIVES

### Alpha Omega

Turbo 10 \$739

### Imega

Bernoulli Box for IBM 10 Megabyte \$1950  
20 Megabyte \$2660

### Rana

Elite I \$179  
Elite II \$339  
Elite III \$405  
Elite 10H/Apple \$1080  
Controller (W/Drive Only) \$69  
1000 W/DOS for Atari \$305

### Tallgrass

TG-3020 \$2289  
TG-3135 \$3689  
TG-4060 \$1469

## BOARDS

### AST

Six Pack Plus \$259

### Paradise

Modular Graphic 06-1 \$275  
Five Pak \$150

**ZENITH/JUKI**  
Zenith Z-150 Dual Drive 320K Ram  
Zenith Green or Amber Monitor  
Juki Juki 6100 Letter Quality Printer  
Includes Cables and Shipping

**\$2499**

**\$2575**

Above System with Z-160 Dual Drive Portable (No monitor)

## VIDEO TERMINALS

### ADDS

A-2 Green \$469  
A-3 \$469

### Altos

Smart II \$699

### Qume

QVT 102 Green \$399  
QVT 102 Amber \$419  
QVT 103 Green \$816  
QVT 103 Amber \$850  
QVT 108 Green \$449  
QVT 108 Amber \$519

### Televideo

800 \$1225  
800A \$ 979  
910 \$ 425  
910+ \$ 559  
921 \$ 449  
922 \$ 755  
924 \$ 639  
925 \$ 699  
925E \$ 599

### Wyse

50 \$489  
75 \$565

### Zenith

Z-22 \$469  
Z-29 \$599  
Z-49 Save

## DISKETTES

### Maxell

MD-1 (Qty 100) \$175  
MD-2 (Qty 100) \$199

## TEC MAR

Graphics Master \$449  
128K Dynamic Memory \$225  
256K Dynamic Memory \$299  
Captain 128K \$299  
Captain 256K \$399

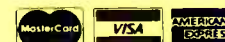

Prices reflect 3% to 5% cash discount. Product shipped in factory cartons with manufacturer's warranty. Please add \$8.00 per order for UPS shipping. Prices & availability subject to change without notice. Send cashier's check or money order...all other checks will delay shipping two weeks.

**SILICON SPECIALTIES**  
2034 WEST SOUTHERN  
MESA, ARIZONA 85202  
602-969-0909

# THE TECHNOLOGY OF EXPERT SYSTEMS

BY ROBERT H. MICHAELSEN, DONALD MICHIE, AND ALBERT BOULANGER

## *Transplanting expert knowledge to machines*

THE PURPOSE OF this article is to introduce expert systems. Initially, we'll define these systems. Next, we'll discuss methods for building them, including the advantages and disadvantages of each method. Finally, we'll review the computer resources needed to build and run expert systems.

### DEFINITION

Expert systems are a class of computer programs that can advise, analyze, categorize, communicate, consult, design, diagnose, explain, explore, forecast, form concepts, identify, interpret, justify, learn, manage, monitor, plan, present, retrieve, schedule, test, and tutor. They address problems normally thought to require human specialists for their solution. Some of these programs have achieved expert levels of performance on the problems for which they were designed (see reference 6).

Expert systems are usually developed with the help of human experts who solve specific problems and reveal their thought processes as they proceed. If this process of protocol

analysis is successful, the computer program based on this analysis will be able to solve the narrowly defined problems as well as an expert. (For a discussion of successful expert systems, see reference 2.)

Experts typically solve problems that are unstructured and ill-defined, usually in a setting that involves diagnosis or planning. They cope with this lack of structure by employing heuristics, which are the rules of thumb that people use to solve problems when a lack of time or understanding prevents an analysis of all the parameters involved. Likewise, expert systems employ programmed heuristics to solve problems. Figure 1 is an example of a complex heuristic used by TAXADVISOR, an expert system that gives estate-planning advice (see reference 17).

Experts engage in several different problem-solving activities. For instance, the following problem-solving activities have been identified in MYCIN (see figure 2): identify the problem, process data, generate questions, collect information, establish hypothesis space, group and dif-

ferentiate, pursue and test hypothesis, explore and refine, ask general questions, and make a decision (see reference 11).

Experts are capable of

- Applying their expertise to the solution of problems in an efficient manner. They are able to employ plausible inference and reasoning from incomplete or uncertain data.
- Explaining and justifying what they do.
- Communicating well with other ex-

*(continued)*

Robert H. Michaelson is an assistant professor of accounting at the University of Nebraska (Lincoln, NE 68588-0488). He received his Ph.D. in accountancy from the University of Illinois. Donald Michie is Director of Research at the Turing Institute (36 North Hanover St., Glasgow G1 2AD, Scotland). Formerly a professor at the University of Edinburgh, he is the author of numerous books and articles on artificial intelligence. Albert Boulanger is a scientist for Bolt Beranek and Newman Inc. (10 Moulton St., Cambridge, MA 02238). He has a master's degree in computer science from the University of Illinois at Urbana-Champaign.



perts and acquiring new knowledge.

- Restructuring and reorganizing knowledge.
- Breaking rules. They have almost as many exceptions as they have rules. They understand both the spirit and the letter of a rule.
- Determining relevance. They know when a problem is outside their expertise and when to make referrals.
- Degrading gracefully. At the boundaries of their expertise, they become gradually less proficient at solving problems, rather than suddenly incapable (see reference 4).

Expert systems have modeled only the first three expert capabilities to any extent, and even explanation and knowledge acquisition have just begun.

Expert systems, like human experts, can have both deep and surface representations of knowledge. Deep representations are causal models, categories, abstractions, and analogies. In

such cases, we try to represent an understanding of structure and function. Surface representations are often empirical associations but are sometimes "compiled" from an understanding of structure and function. In the former case, the association between premises and conclusions of rules is based on empirical observation of past association. Causality is implicit in the rule, rather than explicit.

Deep representations enhance the explanatory powers of expert systems. With surface representations, all the system knows is that an empirical association exists; it is unable to explain why, beyond repeating the association. Where more fundamental insight is available, deep representation will enable the system to respond more substantively. If computer induction is used for knowledge acquisition, a model for understanding events in the domain (a deep representation) often guides the induction of rules from examples by

distinguishing meaningful hypotheses from coincidences in the data. It is also likely that deep representation will enhance the incorporation of the last four previously listed expert capabilities into expert systems. Surface representations have offered little in this regard.

However, surface representations have their advantages if the only concern is problem-solving performance, empirical associations, or compiled understanding. They should be less costly to formulate than causal models. This lower cost can provide a reasonable level of explanation along with a primitive form of knowledge acquisition. If a domain's expertise is based on empirical association, as in many areas of medicine, surface representations are the only kind available (see reference 4).

The best approach to expert-system building is probably to use deep representations when they are cost-effective and surface representations for the rest of the system. This approach has already been explicated in a paper by Hart (reference 12) and implemented in Digitalis Advisor, a system that provided advice on digitalis dosages for cardiac patients (see reference 29).

### BUILDING EXPERT SYSTEMS

An expert system is able to make decisions on a par with an expert primarily because its structure reflects the manner in which human specialists arrange and make inferences from their knowledge of the subject. The system is driven by a database of inexact and judgmental knowledge that is typically made up of if-then rules when surface representation is used, or frames and semantic nets when deep representation is used (see "A Glossary of Artificial Intelligence Terms" on page 138). Domain knowledge is processed in a strict order of deductive inference and is invoked by a pattern match with specified features of the task environment. Figure 3 is an example of pattern matching by TAXADVISOR. Because uncertainty is usually involved in expert judgments, expert systems must allow

#### RULE 216

(This rule applies to clients and is tried to find out whether a short-term trust should be recommended.)

- If:
- 1) The client and/or spouse do wish to shift property income to another (not for legal support), etc., for at least 10 years or until the death of the beneficiary,
  - 2) The client and/or spouse do desire to eventually reclaim control of this property (for retirement, estate liquidity, etc.),
  - 3) The client and/or spouse are in a higher income bracket than the beneficiary,
  - 4) The client and/or spouse are willing to relinquish control of the beneficial enjoyment of the property,
  - 5) The client and/or spouse are able to provide for their living needs without this income, even in the event of disability or unemployment,
  - 6) The client and/or spouse do not plan to have the trust income used to pay life-insurance premiums on his/her life without the consent of an adverse party,
  - 7) The client and/or spouse do not plan to use the trust for a leaseback of assets, and
  - 8) A: The client and/or spouse have a person (eg., a parent) they are supporting without legal obligation with this property income (will lose a dependent if trust is formed),  
 B: The client and/or spouse have a child, not a minor, that they will be putting through college with this property income (can set up early and accumulate income without tax problems), or  
 C: The client and/or spouse are using some of their after-tax income for the benefit of some other taxpayer (child's marriage and/or home purchase, etc.).

Then: It is definite (1.0) that client should TRANSFER ASSETS TO A SHORT-TERM TRUST.

Figure 1: An example of a TAXADVISOR rule.

conclusions to be reached with less than certainty. Figure 4 illustrates how TAXADVISOR copes with uncertainty during a consultation. (For more information on uncertainty mechanisms in expert systems, see reference 32.)

The type of computer program that is used to develop an expert system cannot have its flow of control and data utilization rigidly fixed because such a structure is ill-adapted for simulating a human's responses to a complex, rapidly changing, and unfamiliar environment. Instead, such a program must examine the state of the world at each step of the decision process and react appropriately because new stimuli continually arise. The type of program that has been developed to cope with this constant change is a loosely organized collection of pattern-directed modules (PDMs) that detect situations and respond to them (see reference 31). The rule in figure 1 is a PDM from TAX-ADVISOR.

Each PDM examines and modifies data structures that model critical aspects of the external environment. In TAXADVISOR, the client's financial-planning situation and objectives constitute the environment. A PDM should be written as a single and separate unit that is independently meaningful within the task domain of the program. This aids incremental program growth and debugging, since revision of one PDM does not affect the others. It also provides explanation power; a single PDM can be used to explain a recommendation by the system.

Any system composed of several PDMs, one or more data structures that may be examined and modified by the PDMs, and an executive program to schedule and run the PDMs is called a pattern-directed inference system (PDIS). In effect, a PDIS factors complex problems into manageable, largely independent subproblems.

**SURFACE REPRESENTATIONS**

Rule-based systems (RBSs) were originally used in cognitive modeling of short-term memory. Since expert

(continued)

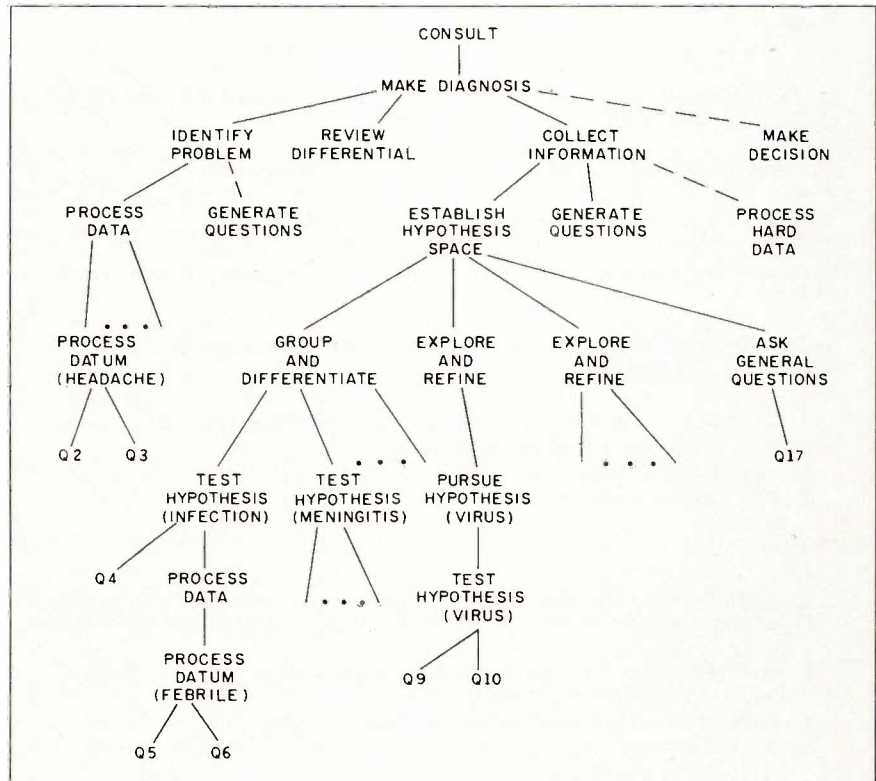

Figure 2: The MYCIN problem-solving hierarchy. Question numbers (Q2, etc.) correspond to questions asked in the consultation. Solid lines show tasks actually done, dashed lines those that might be done. (Figure used with permission; see reference 11.)

Necessary Attributes for Short-Term Trust	Prestored Value	Client's Value
1) Does client wish to shift property income to another (not for legal support) for at least 10 years or until the death of the beneficiary?	yes	yes
2) Does client desire to eventually reclaim control of the property?	yes	yes
3) Is client in a higher income-tax bracket than the beneficiary?	yes	yes
4) Is client willing to relinquish control of the beneficial enjoyment of the property?	yes	yes
5) Is client able to provide for his living needs without this income even if disabled or unemployed?	yes	yes
6) Does client plan to have trust income pay life-insurance premiums on his life without consent of an adverse party?	no	no
7) Does client plan to use the trust for a leaseback of assets?	no	no
8) Does client have a person he is supporting without legal obligation?	yes	yes

Figure 3: An example of pattern matching done by TAXADVISOR, performed to determine if the client should be forming a short-term trust. The Prestored Value column shows the pattern of attribute values that a client must have before TAXADVISOR will recommend a transfer of assets to a short-term trust. Since the client's pattern matches the prestored one, the trust will be recommended.



```

(begin)
                —Formation of a Temporary Trust—

1) Does client wish to shift property income to another (not for legal support) for at
   least 10 years or until the death of the beneficiary?
**YES
2) Does client desire to eventually reclaim control of the property?
**YES
3) Is client in a higher income-tax bracket than the beneficiary?
**YES
4) Is client willing to relinquish control of the beneficial enjoyment of the property?
**WHY

This will aid in determining whether client should form a temporary trust. It has
already been established that

    1) Client wishes to shift property income to another (not for legal support) for at
       least 10 years or until the death of the beneficiary,
    2) desires to eventually reclaim control of the property, and
    3) is in a higher income-tax bracket than the beneficiary.

Therefore, if

    1) client is willing to relinquish control of the beneficial enjoyment of the property,
    2) is able to provide for his living needs without this income, even if disabled or
       unemployed,
    3) does not plan to have trust income pay life-insurance premiums on his life
       without the consent of an adverse party,
    4) does not plan to use the trust for a leaseback of assets, and
    5) A: has a person (e.g., a parent) he is supporting without legal obligation with
       this property income,
       B: has a child, not a minor, that he will be putting through college with this
       property income, or
       C: is using some of his after-tax income for the benefit of some other
       taxpayer,

then

        client should form a temporary trust
        (back to question 4 . . .)

**YES

5) Is client able to provide for his living needs without this income, even if disabled
   or unemployed?
**YES (8) [Whenever a response is made with less than certainty, the system user
enters a number between 1 and 9 indicating his degree of certainty in that response.]
6) Does client plan to have trust income pay life-insurance premiums on his life
   without consent of an adverse party?
**NO
7) Does client plan to use the trust for a leaseback of assets?
**NO
8) Does client have a person he is supporting without legal obligation?
**YES

I recommend that the client form a short-term trust.
[The degree of certainty that the system has in this recommendation is .8. This
certainty factor (CF) was calculated as follows. The temporary trust rule's action CF
was 1.0 and it had an "AND" premise. In such a case, the rule's CF is the minimum
CF used in the responses, or .8. Since the system's threshold CF is .2, the
recommendation was made.]

(end)

```

systems attempt to imitate people, it was natural that RBSs would also be used in their development. To date, RBSs are by far the most common structure for expert systems. Among the successful rule-based expert systems that have been developed are the following:

- MYCIN—diagnoses infections (reference 26)
- HEURISTIC DENDRAL—identifies organic compounds (reference 8)
- PROSPECTOR—aids geologists in evaluating mineral sites (reference 5)
- PUFF—analyzes pulmonary function tests (reference 15)
- INTERNIST—performs diagnosis in internal medicine (reference 22)
- XCON (formerly R1)—configures the VAX-11/780 computer system (reference 16)
- SACON—provides engineers with advice on structural analysis (reference 1)

Because of the popularity of RBSs, several domain-independent systems have been developed to make it much easier to build rule-based expert systems in many fields. The following is a partial list of domain-independent systems:

- EMYCIN (reference 30)
- AGE (reference 21)
- OPS5 (reference 16)
- ADVISE (reference 18)
- Hearsay-3 (reference 7)
- AL/X (reference 23)
- Expert-Ease (Human Edge Software Corp., Palo Alto, California)
- KS 300 (Revamped EMYCIN; from Teknowledge Inc., Palo Alto, California)
- KES (Intelligenetics Inc., Palo Alto, California)
- Personal Consultant (Texas Instruments Inc., Dallas, Texas)

An RBS is composed of PDMs called rules, each with a left-hand side (the antecedent, a logical combination of propositions about the database) and a separate right-hand side (the consequent, a collection of actions). An RBS separates data examination (done by the left-hand side) from data modification (done by the

Figure 4: A partial interactive consultation with TAXADVISOR. The user's input is in uppercase.

## EXPERT TECHNOLOGY

right-hand side of the rule).

Most RBSs are production systems (PSs), in which matching and scheduling are explicitly defined by the operation of the executive (control) program. The control schema can be characterized as having four basic parts:

1. Selection: select relevant rules and data elements. Selection may be trivial (e.g., on each cycle all rules and all data elements can be considered) or quite complex (e.g., special filters can be designed to eliminate from consideration many rules that could not possibly match the current data). In TAXADVISOR, rules are organized in a hierarchy to narrow the rules considered.

2. Matching: compare active rules against active data elements, looking for patterns that match, i.e., rules whose conditions are satisfied. Figure 3 is an example of pattern matching.

3. Scheduling: decide which "satisfied" rule should be "fired." "Firing" consists of accessing and executing the procedures associated with the pattern elements that matched the current data. If more than one rule is satisfied, conflict-resolution heuristics are used to decide which rule to fire.

4. Execution: fire the rule chosen during the scheduling process. The result of execution is a modification of data elements or structure. With TAXADVISOR, execution results in an estate-planning recommendation for a client. This is illustrated in the test consultation in Figure 4 (see reference 31).

PSs are either consequent-driven systems or antecedent-driven systems. A consequent-driven (backward-chaining) system, which is the type used in TAXADVISOR, uses rule consequents (which represent goals) to guide the search for rules to fire (with TAXADVISOR, estate-planning actions to recommend). The system collects those rules that can satisfy the goal in question and tries to satisfy the consequents of those rules, which usually represent the values of variables. In order to find these values, the values of the rule antecedent must

be found. To satisfy each antecedent, which represents a subgoal, the system collects those rules whose consequents satisfy its value. The process of working backward through the rules from consequents to antecedents to consequents in search of a causal chain that will satisfy the goal is called backward chaining. (For a simple backward-chaining program written in BASIC, see "Knowledge-Based Expert Systems Come of Age" by Richard O. Duda and John G. Gaschnig, September 1981 BYTE, page 238.)

With antecedent-driven (forward-chaining) systems, program execution consists solely of a continuous sequence of cycles terminating when a rule's action dictates a halt. At each cycle, the system scans the antecedents and determines all rules with antecedents that are satisfied by the contents of the database. If there is more than one such rule, select one by means of a conflict-resolution strategy. Perform all actions associated with the selected rule and change the database accordingly. For example, with R1 (XCON), you enter all the information on the problem into the database, and the system then applies the rules to reason forward from the data to the conclusions. In summary, forward chaining consists of putting the rules in a queue and then using a recognize-act cycle on them.

Some forward-chaining systems try to control the search for rules in the recognize cycle by grouping rules into packets. These rule groupings are appealing conceptual structures, since they group rules according to the subtopic that they deal with. Object-oriented programming can also be used to organize collections of rules. In object-oriented programming, we give objects behavior, and thus we can distribute the control of rules into rule, rule-packet, and domain objects. This approach, which has been taken in LOOPS, a domain-independent system (see reference 27), also allows multiple instantiations of the same set of rules to solve subproblems of the

(continued)

## Why do major hardware vendors endorse GOLDEN COMMON LISP?

*"Wang Laboratories sees the COMMON LISP Standard as an important element of its strategy for advanced Office Automation. Wang Laboratories and Gold Hill Computers are both committed to bringing Artificial Intelligence technology to Office Automation and see COMMON LISP on the Wang product family as a vital step."*

Leo Chan  
Vice President, R&D  
Wang Laboratories

*"Ideal for entry-level AI operations, the program package was designed to provide training for programmers as well as for program development. As a subset of COMMON LISP, it is compatible with Digital's recently announced VAX LISP."*

Arnold Kraft  
AI Marketing  
Digital Equipment Corporation

*"With the availability of these packages, the DATA GENERAL/One gives engineering users a 'personal expert system' with both a standalone software development workstation and a distributed development tool in a single, portable computer."*

Don McDougall, Vice President and General Manager  
Technical Products Division  
Data General

*"GOLDEN COMMON LISP is the best AI delivery environment available on a PC. Networks of PCs can be connected to Symbolics LISP machines to provide powerful distributed AI applications at affordable prices."*

Bruce M. Gras  
Vice President, Marketing  
Symbolics, Inc.

  
GOLD HILL  
COMPUTERS

AI Solutions for Personal Computing

163 Harvard Street, Cambridge  
Massachusetts 02139 (617) 492-2071

See our ad on page 129



# Finally, business computer software for the hard-nosed.

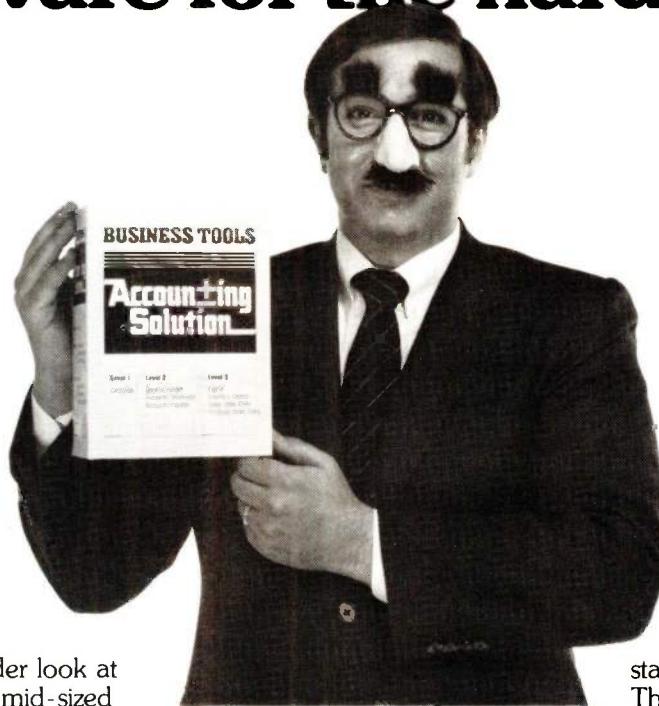

No one takes a harder look at software than small to mid-sized businesses.

So take a long, hard look at The Accounting Solution™, a new, totally integrated software package from Business Tools, Inc.™

You'll find its breakthrough features are designed to pay off where it counts—on the bottom line.

## Hard-nosed economy, \$99.\*

Contrary to popular opinion, you don't need a small business loan to buy quality software. Not if you're buying The Accounting Solution. For \$99, you get a language/data base manager with more hard-nose capabilities and speed than any program available at any price; \$249 buys the language plus accounts receivable/payable and general ledger; \$399 gets you all the above plus inventory control, sales order entry, purchase order entry and payroll. Even more good news for the budget minded—source code is included with applications.

## Easy for any hard-nose.

The Accounting Solution is easy

enough for the novice hard-nose to use within minutes of receiving the package. Yet it's also sophisticated, offering unlimited flexibility and opportunity to the hot-shot hard-nose. And it's designed to run on CP/M-80, MP/M-80, IBM PC and compatibles.\*\*

## Multi hard-nose capability.

The Accounting Solution never

stands in the way of progress.

Thanks to multi-user capability, two or more hard-noses can use the same application at the same time.

## Hard-nosed flexibility.

With The Accounting Solution, it's easy to change your mind because the source code is so simple to modify. Ready to grow? Great. You can change hardware without spending a dime on new software.

## Take it from hard-nose Phil Mickelson.

Phil created The Sensible Solution,\*\* a highly respected software package. Now he's offering the next step, another breakthrough: The Accounting Solution. It's simple. Sophisticated. Affordable. And backed by Phil's reputation and personal service. If you're looking for hard-nosed value and quality, you'll agree, The Accounting Solution is the only solution.



Write or call:

**Business Tools, Inc.**  
4038-B 128th Avenue SE  
Bellevue, WA 98006

**1-800-648-6258**

**Washington State:**  
**(206) 644-2015**

*Dealer inquiries welcome.*

\* Suggested retail price.

\*\* CP/M-80 and MP/M-80 are registered trademarks of Digital Research, Inc.; IBM PC is a registered trademark of International Business Machines Corporation; The Sensible Solution trademark rights are claimed by O'Hanlon Computer Systems.

## EXPERT TECHNOLOGY

same type within one session.

The primary difference between backward and forward chaining is a top-down versus bottom-up style of linking rules together. Though the most common, these are not the only control structures for rule-based systems. For example, rules are represented as an "inference" network in PROSPECTOR (see reference 5).

### DEEP REPRESENTATIONS

Frame- and network-based approaches allow the implementation of "deeper-level" reasoning such as abstraction and analogy. Reasoning by abstraction and analogy is an important expert activity. You can also represent the *objects* (e.g., "pump" in figure 5) and *processes* (e.g., the "start" instructions in figure 5) of the domain of expertise at this level. What is important are the *relations between objects*. Deep-representation expert systems perform inference using relations rep-

resented by networks or frames. A semantic network is a graph of the relations. A frame or script system (see references 20 and 24) organize the objects and their relations into *entities* (recognizable collections of objects). Frame systems also provide a system to inherit attributes from a taxonomy of entities. Thus, a frame system implements the semantics of some of the relations between objects. With a semantic-net or frame system you can represent objects of the domain of expertise as well as the process, strategies, etc., that are also part of the domain. The control of frame or semantic-net systems is usually much more involved than with surface systems and is implemented in a way that an explanation facility can't get at. But surface systems are "shallow"; a surface system may be viewed as a projection of deep-level knowledge of a domain for a specific

(continued)

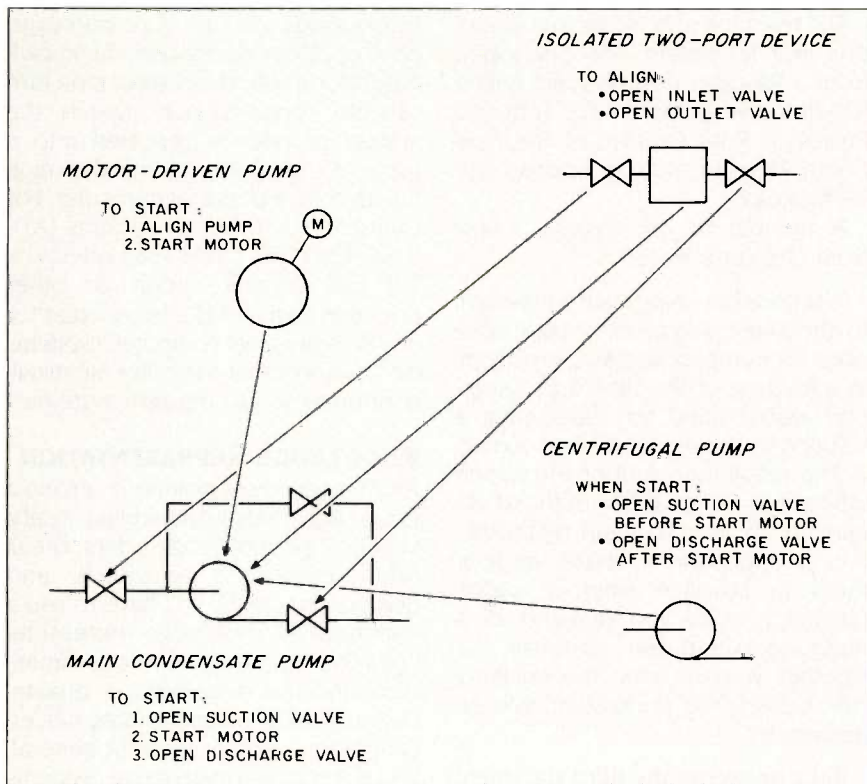

Figure 5: Procedure steps are obtained from the subcomponents and abstractions of an object, here a main condensate pump. This example comes from Steamer, a tutorial system designed to teach operating procedures of shipboard steam plants.

## Why do large corporations purchase GOLDEN COMMON LISP?

*"I'm not a programmer. Having completed the Gold Hill tutorial, I feel comfortable in starting to write useful AI programs. We hope to build friendlier user interfaces using expert systems. This product should help us to develop the in-house expertise in a cost-effective manner."*

H.M. Seeburg  
 Program Management Systems  
 Hughes Aircraft Company

*"The AI Group at Arthur Andersen & Company is intending to use GOLDEN COMMON LISP as a delivery environment for a major internal application. We are also using it as a vehicle for training a large base of firm personnel in AI technology."*

Bruce B. Johnson  
 Partner in charge of the AI Group  
 Arthur Andersen & Company

*"A primary concern for Litton Industries has been finding an appropriate delivery vehicle for AI applications. The availability of this product opens up new avenues of potential for us."*

Sy Schoen  
 Program Manager for AI  
 Litton Industries

*"GOLDEN COMMON LISP provides a powerful LISP environment that allows even a novice to create meaningful LISP programs. With the On-line Help facilities and tutorial, the product is an inexpensive entry-point for companies of all sizes into this critical technology!"*

Brad Millman  
 Member of AI Core Group  
 Arthur D. Little

*"GOLDEN COMMON LISP is exciting! It will do for AI what Wang Laboratories did for word processing—popularize it."*

Dan Corwin  
 Software Architect  
 Wang Laboratories



AI Solutions for Personal Computing

163 Harvard Street, Cambridge  
 Massachusetts 02139 (617) 492-2071

See our ad on page 129



*Some systems have  
a built-in capability  
for taking a file  
of expert decisions  
and generalizing  
from this knowledge  
an executable rule.*

expert activity.

One type of expertise that has been represented with a deep-level approach is tutoring (see "The LISP Tutor" by John R. Anderson and Brian J. Reiser on page 159). Here we want to convey to the pupil domain knowledge that is best represented at the deep level: concepts, abstractions, analogies, and problem-solving strategies.

Steamer is a training aid developed jointly by Bolt Beranek and Newman Inc. and the Navy Personnel Research and Development Center. Its goal is to teach operating procedures of shipboard steam plants. These procedures consist of a series of steps on subcomponents of the plant. The components and procedures are represented as frames in Steamer, as are the abstractions of components and procedures that experts use in teaching steam-plant operations. The steps of a procedure come from the abstractions and subcomponents of the device the procedure applies to. The ordering of the steps comes from a third represented entity: operating principles. These principles are culled from experienced operators and represent "compiled" knowledge of steam-plant operation (although they are not represented as rules but frames).

**KNOWLEDGE ACQUISITION**

The following are ways of acquiring knowledge in a form that can be used by an expert system (reference 19):

- being told
- analogy
- example
- observation, discovery, and experimentation
- reasoning from deep structure

The manual acquisition of knowledge from human experts is a very labor-intensive process. There is an acknowledged need to have aids for knowledge acquisition as part of the system.

Methods to speed knowledge acquisition are now becoming available in the form of machine learning of rules from examples. Systems such as Expert-Ease have a built-in capability for taking a file of expert decisions from you and generalizing from these an *executable rule*. In a sense, you are able to transplant chunks of decision-making skill from your own brain to the personal computer, a possibility foreseen as early as 1966 by Earl Hunt and his colleagues.

The machine procedure that allows this skill transplant was developed from a Pascal-coded program called ID3 (Iterative Dichotomiser 3) due to Professor Ross Quinlan of the New South Wales Institute of Science and Technology.

A number of conclusions follow from Quinlan's work:

1. It is possible, using such a program, to generate machine-executable solutions for complex decision problems in a fraction of the time a programmer would need for developing a solution by conventional hand coding.
2. The resulting solutions are super-efficient as compared with those obtainable by the old hand methods.
3. It is important to make up your mind in advance whether super-efficiency is all you demand of a machine-executable solution, or whether you *also* want the resulting rule base to be understandable on inspection.

If the answer to the third statement above is that user transparency of induced rules is desired, then (unless it is a very small one) do *not* treat your problem as one big superproblem

with a single associated file of examples. Instead, first break it down into a main problem and a set of sub-problems, even going further (to the level of sub-subproblems) if the complexity of the problem domain seems to call for it. The originators of this style, which is known as "structured induction," are Drs. Shapiro and Niblett (reference 25). Corporations enjoying the use of powerful inductive generators such as ITL's FORTRAN-based EX-TRAN system or Radian Corporation's C-coded RuleMaster have applied the approach to the building of complex systems for troubleshooting large transformers, severe-storm warning, circuit-board fault diagnosis, and user-friendly guidance to set up numerical batch jobs in seismic analysis in the oil industry. Rates of production of compact installed code in excess of 100 lines per worker day are now commonly reported.

Any robust expert system takes a tremendous amount of resources to develop. Once developed, the knowledge along with the control structure can be "compiled out"; that is, the system of rules is rewritten into a piece of code that performs the same function on a personal computer. For example, some expert systems (ADVISE, EMYCIN, OPS5—see reference 10) can generate code or other primitive forms of the knowledge for use on a personal computer. (Systems run on a personal computer are usually referred to as "delivery systems.")

**KNOWLEDGE REPRESENTATION**

As AI researchers point out, a robust expert system that can explain, justify, acquire new knowledge, adapt, break rules, determine relevance, and degrade gracefully will have to use a multitude of knowledge representations that lie in a space whose dimensions include deep/surface, qualitative/quantitative, approximate (uncertain)/exact (certain), specific/general, and descriptive/prescriptive. Systems that use knowledge represented in different forms have been termed *multilevel systems*. Steamer is an example of one such expert system.

## EXPERT TECHNOLOGY

Steamer uses the following representations:

1. A graphical (icon) representation of the objects of the Steamer domain, such as valves, pumps, tanks, and systems composed of these.
2. A frame representation of Steamer objects, procedures, and operating principles. This is used for describing, explaining, categorizing, abstracting, and referring.
3. An assertional database where assertions about Steamer entities can be made and retracted.
4. A quantitative numerical simulation of the steam plant that is used in illustrating cause and effect and ramifications of the application (or misapplication) of procedures.

Work is just beginning in building such multilevel systems, and they will be a major research topic for this decade. Work needs to be done in studying and representing in a general way the different problem-solving activities an expert does (see reference 3). When you build expert systems, you realize that the power behind them is that they provide a regimen for experts to crystallize and codify their knowledge, and in the knowledge lies the power.

### RESOURCES NEEDED

Before resource needs are discussed, you must precisely define the type of expert system you want to build. If you wish to build a large, "custom" model expert system (i.e., it is not feasible to use many of the smaller domain-independent systems that are available), you will need substantial resources: large memory, good language support, and fast execution of the code. You may need to develop such a system in LISP on hardware specialized to processing the language, or on time-sharing machines with a large address space. Such "custom" systems are usually referred to as "prototype" or "development" systems. They can either be developed for a specific domain (e.g., MYCIN) or be domain-independent (e.g., ADVISE).

If you are able to build a less com-

plex expert system using an existing domain-independent system or if the system has a rule-compilation facility that allows applications to be run on personal computers, then a personal computer (preferably with 512K bytes) is sufficient. If all you need are resources to run an existing expert system, a large personal computer should nearly always be sufficient.

There is no obvious line of demarcation for a given project. However, certain barriers make personal computer use less desirable as system size and complexity increase.

### SYSTEM BARRIERS

Many high-level languages do not offer the right primitives (i.e., programming-language statements) for developing expert systems. Among the desirable primitives are

- A parser or interpreter that parses statements during program run time. Without this, you have to write a parser for the rules.
- List and nonnumeric processing primitives.
- A language design that allows incremental compilation and other fast prototyping facilities. Incremental compilation enables you to recompile a function or other portion of a file without recompiling the entire file.

The view that many people in the field are adopting is that high-level languages like Pascal, Ada, and C are acceptable for the delivery system, but for prototyping, a language like LISP or Prolog is preferred. Program-generation tools are then used to write the system in the delivery language.

The knowledge-intensive approach to expert systems implies that the memory will be highly utilized in all but the most nontrivial applications. AL/X is one example that ran on a 64K-byte machine, but it was a small expert-system shell. Since memory prices have gone down and many small machines have broken the 64K-byte barrier, we can expect that more expert systems can be developed, at least for the delivery system, on per-

(continued)

## Why do the AI experts recommend GOLDEN COMMON LISP?

*"We are excited about this product and its potential to optimize the method by which people learn. Included in our forthcoming book on Automatic Deduction and Theorem Proving will be software written in GOLDEN COMMON LISP. This will give students first-hand experience with advanced programs written in the standard LISP dialect on their own PC."*

Woody Bledsoe, President  
American Association for  
Artificial Intelligence  
Michael Ballantyne  
University of Texas, Austin

*"I'm used to working on a Symbolics 3600, yet I am quite comfortable moving to the PC using GOLDEN COMMON LISP. GCLISP is a very respectable subset of the COMMON LISP dialect. . . . In summary: this is a superb product. It puts state-of-the-art LISP programming technology into the hands of anyone who can afford a PC."*

David Touretzky  
Computer Science Department  
Carnegie Mellon University

*"Gold Hill has an enormous competitive advantage in the AI game. It is located next door to MIT, and has direct access to the students and faculty of the MIT AI Lab. The people at Gold Hill have done some highly original thinking about how to dramatically increase the amount of computing power available to personal computer users."*

Howard Austin, President,  
Knowledge Analysis Inc.

*"There are a lot of people eager to get their hands on this stuff. I think this will bring AI to the masses."*

Patrick H. Winston  
Director of the AI Lab, MIT  
President-elect, American  
Association for Artificial  
Intelligence



AI Solutions for Personal Computing

163 Harvard Street, Cambridge  
Massachusetts 02139 (617) 492-2071

See our ad on page 129



*Some researchers predict that memory needs of advanced expert systems will drive development of encyclopedic memories.*

sonal computers. Some researchers predict that the memory needs of advanced expert systems will drive the development of encyclopedic memories for personal computers.

**CONCLUSION**

Expert systems can be built in many ways, involving rules, networks, frames, and combinations thereof, with all sorts of variations within these categories with respect to knowledge representation and control. We could not begin to cover all possible approaches to building expert systems, since new ones are being developed almost daily.

Even if the most efficient approach has been ascertained for the domain in question, the most cost-effective computer resource must still be determined. In most cases, approach selection at least narrows the choice for resources; in some cases, approach and resources can be selected together. However, this hardly reduces the complexity of the choice. To make matters worse, computer resources are changing as rapidly as the new system-building approaches are being developed. The best we can hope to convey is an awareness of the opportunities and complexities involved in the development of expert systems. ■

**REFERENCES**

1. Bennett, J. S., and R. S. Englemore. "SACON: A Knowledge-Based Consultant for Structural Analysis." *IJCA*, 179, 1979, page 47.  
 2. Bramer, M. A. "A Survey and Critical Review of Expert Systems Research." *Introductory Readings in Expert Systems*, D. Michie,

ed. London and New York: Gordon and Breach, 1982.  
 3. Chandrasekaran, B., and Sanjay Mittal. "Deep Versus Compiled Knowledge Approaches to Diagnostic Problem-Solving." *International Journal of Man-Machine Studies*, #19, 1983, page 425.  
 4. Davis, R. "Expert Systems: Where Are We? and Where Do We Go From Here?" *AI Magazine*, Spring 1982, page 3.  
 5. Duda, R., J. Gaschnig, and P. Hart. "Model Design in PROSPECTOR Consultant System for Mineral Exploration." *ESMA*, 1979, page 153.  
 6. Duda, R. O., and E. H. Shortliffe. "Expert Systems Research." *Science*, April 1983, page 261.  
 7. Erman, L. D., P. E. London, and S. F. Fickas. "The Design and Example Use of Hearsay 3." *Proceedings of IJCA no. 7*, 1981, page 409.  
 8. Feigenbaum, E. A., B. G. Buchanan, and J. Lederberg. "On Generality and Problem Solving: A Case Study Using the DENDRAL Program." *Machine Intelligence 6*, B. Meltzer and D. Michie, eds. New York: Edinburgh University Press and Halsted Press (Wiley), 1971, page 165.  
 9. Forbus, Kenneth D. "Qualitative Process Theory." *MIT Technical Report 789*, MIT AI Laboratory, May 1984.  
 10. Forgey, C. L. "Rete: A Fast Algorithm for the Many Pattern/Many Object Match Problem." *Artificial Intelligence*, September 1982.  
 11. Hasling, Diane Warner, William J. Clancey, and Glenn Rennels. "Strategic Explanations for a Diagnostic Consultation System." *International Journal of Man-Machine Studies*, January 1984, page 3.  
 12. Hart, P. "Direction for AI in the 80's." *SIGART Newsletter*, November 1981, page 11.  
 13. Hollan, James, Edwin Hutchins, and L. Weitzman. "Steamer: An Interactive Inspectable Simulation-Based Training System." *AI Magazine*, Summer 1984, page 15.  
 14. Hutchins, Edwin, Terry Roe, and James Hollan. "Project STEAMER: VII. A Computer-Based System for Monitoring the Boiler Light-Off Procedure for a 1078-Class Frigate." *NPRDC Technical Note 82-85*, August 1982.  
 15. Kunz, J. C., et al. "A Physiological Rule-Based System for Interpreting Pulmonary Function Tests." Heuristic Programming Project, Memo HPP-78-19, Stanford University, 1978.  
 16. McDermott, J. "RI: A Rule-Based Configurator of Computer Systems." Computer Science Department, Carnegie-Mellon University, 1980.  
 17. Michaelsen, R. H. "An Expert System for Federal Tax Planning." *Expert Systems: The International Journal of Knowledge Engineering*, October, 1984, page 149.  
 18. Michalski, R. S., A. B. Baskin, A. Boulanger, R. Reinke, L. Rodewald, M. Seyler, K. Spachman, and C. Uhrik. "A Technical Description of the ADVISE Meta Expert System." Department of Computer Science, University of Illinois at Urbana-Champaign, 1983.  
 19. Michalski, R. S., J. Carbonell, and T. Mitchell, eds. *Machine Learning: An Artificial Intelligence Approach*. Los Altos, CA: Tioga Publishing Company, 1983.  
 20. Minsky, M. "A Framework for Representing Knowledge." *The Psychology of Computer Vision*, P. Winston, ed. New York: McGraw-Hill, 1975.  
 21. Nii, H. P., and N. Aiello. "AGE (Attempt to Generalize): A Knowledge-Based Program for Building Knowledge-Based Programs." *IJCA*, 179, 1979, page 645.  
 22. Pople, H. E., J. D. Myers, and R. A. Miller. "Dialog: A Model of Diagnostic Logic for Internal Medicine." *IJCA*, 175, 1975, page 848.  
 23. Reiter, J. "AL/X: An Expert System Using Plausible Inference." Intelligent Terminals Ltd., University of Edinburgh, 1980.  
 24. Schank, R. C., and R. P. Abelson. *Scripts, Plans, Goals, and Understanding*. Hillsdale, NJ: Lawrence Erlbaum Associates, 1977.  
 25. Shapiro, A., and T. Niblett. "Automatic Induction of Classification Rules for a Chess Endgame." *Advances in Computer Chess 3*, M. R. B. Clarke, ed. Oxford: Pergamon, 1982.  
 26. Shortliffe, E. H. *Computer-Based Medical Consultations: MYCIN*. New York: American Elsevier/North-Holland, 1976.  
 27. Stefik, Mark, Daniel G. Bobrow, Sanjay Mittal, and Lynn Conway. "Knowledge Programming in LOOPS: Report on an Experimental Course." *AI Magazine*, Fall 1983.  
 28. Stevens, Albert, and Bruce Roberts. "Quantitative and Qualitative Simulation in Computer Base Training." *Journal of Computer Based Instruction*, volume 10, numbers 1 and 2, Summer 1983, page 16.  
 29. Swartout, W. R. "A Digitalis Therapy Advisor with Explanations." *Technical Report 176*, MIT Lab for Computer Science, February 1977.  
 30. Van Melle, W. "A Domain-Independent Production Rule System for Consultation Programs." *IJCA*, 179, 1979, page 923.  
 31. Waterman, D. A., and F. Hayes-Roth, eds. *Pattern-Directed Inference Systems*. New York: Academic Press, 1978.  
 32. Whalen, Thomas, and Brian Schott. "Issues in Fuzzy Production Systems." *International Journal of Man-Machine Studies*, #19, 1983, page 57.



# The most advanced board available.

IBM XT COMPATIBLE

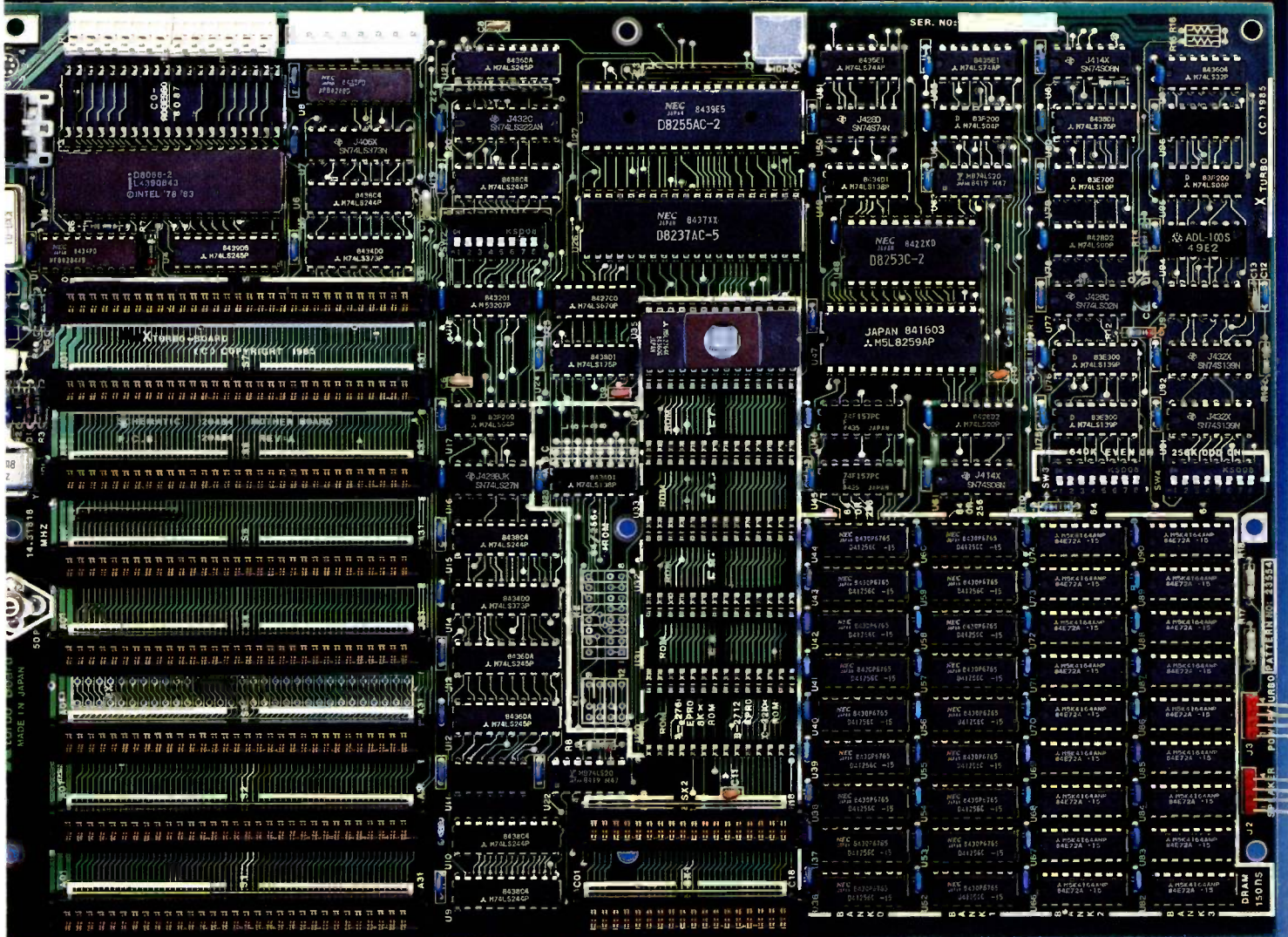

## Xturbo Board™

- High speed 8088-2 CPU micro-processor with 8087 co-processor optional
- 640 K (64K-640K selectable) RAM on board with parity check
- 8K X turbo BIOS
- 4 channel DMA 8237-5
- 8 channel interrupt 8259
- 8 I/O slot XT standard
- IBM pinpoint compatible power connector
- Multilayer P.C.B.
- Same dimension as IBM XT mother board
- Two 18-pin function slots
- Full IBM XT compatibility
- Full 640K RAM (maximum XT memory map RAM address) capacity on X Turbo
- High speed, high efficiency

**ARC** American Research Corporation

Inquiry 57

Dealer inquiries invited. Contact Debra at (818) 289-8742.

2001 W. Chestnut Street Alhambra, CA 91803 (818) 289-8742

\*IBM and IBM XT are trademarks of International Business Machines



# 9th Anniversary Sale Continues!

We will still BEAT any price advertised in this magazine! When we started in 1976, our goal was to bring the power of the mini computer to the individual and small business and to do it at the lowest possible cost. Our hardest job was to find products which performed as promised. Nine years later it's still our hardest job. We now have 3 full time people who evaluate hardware and software systems.

Thousands of even more fantastic items  
Free Catalog!  
call today  
1-800-822-1211



## PRINTERS

<b>OKIDATA</b>	
82, 83, 84, 92, 93, 2350	Call for current prices!
<b>EPSON</b>	
RX80/RX80FT	239/309
FX80/FX100	439/419
RX100/LQ1500	639/1,109
JX80 Color	Call
<b>STAR</b>	
Gemini SG-10/SG-15	269/456
SD-10/SD-15/SR-10	435/580/613
S. Interface	Call
<b>AMDEK</b> The quiet ones	
5025 25 cps Daisy 2K Buff	700
5040 40 cps Daisy 2K Buff	1300
5055 55 cps Daisy 2K Buff	1500

ASK ABOUT FREE PAPER WITH PRINTERS

## COMPUTERS

### ZENITH DATA SYSTEMS

All Zeniths software & hardware fully compatible with the PC & XT superior keyboard as low as \$1295.

ZF 151-20 256K No Drives **Call**  
ZF 151-21 128K 360 **Call**  
ZF 151-52 320K 720 (2 Drives) **Call**  
ZF 151-52 320K 10 6 MB + 360 **Call**  
ZF 161-21 128K 360 **Call**  
ZF 161-52 320K 720 (2 Drives) **Call**

Personal Pearl database manager only \$100 with any Zenith System purchase.

### SANYO

550 & 555 PC's. Built in Software includes Easywriter, Easy Filer, Word-Star, and Calcstar **NOW 100% IBM COMPATIBLE.**  
Call for current prices

## MONITORS

USI 20 MHZ HI Res., Best Buy. 1000 Lines Res. up to 132 Char. Display, 12" Amber Screen only **89**

### ZENITH DATA SYSTEMS

ZVM Series 122, 123, 124, 131, 135.

### PANASONIC

#### SPECIAL PURCHASE

Panasonic 13" Color Monitor RGB and Composite, IBM Compatible.  
List \$449 **Our Price 259.**

220 Mhz with Sound Amp 12 Green/12 Amber **137/125**  
New X-tron Amber TTL IBM-Compaq **125**

### AMDEK Still the Leader

Color I & I + closeout **199/209**  
Video 300/300A/310A **135/145/159**  
Color 300/Color 600 **239/450**  
Color 500/Color 700 **380/520**

### ELECTROHOME

ECM1226 12 green **95**  
1302-1 33 color RGB **195**  
1302-2 13 color RGB H R **330**

## /ETC.

### ADDIN BOARDS

Quadram Quadboard **225**  
Quadlink/Quadcad 512+ **479/255**  
Quadcolor1/chrome II **197/469**

### AST RESEARCH

Six Pack+/Mega+ **245/295**  
Combo+/I/O+ **275/129**

### PARADISE

\* 5 Pack/Graphics **180/315**  
Multi disp./RAM kit (9) **335/25**

### AB SATISFACTION GUARANTEE

Every product sold by AB Computers is factory packed and comes with the manufacturer's warranty. However, if an item is defective when received, you may return it to us within 15 days for repair, adjustment or replacement at our option. Returns must be accompanied with copy of your invoice, letter detailing defect, blank warranty card and all original factory packing. To expedite handling, please call for return authorization number. (Sorry, no return on computer software once opened.)

## Software Super-Hit Parade

### BUSINESS

J.K. Lassers YOUR INCOME TAX B&D A/I **48**  
Lotus 123/Symphony IBM **290.470**  
PFS Graft/Report C/A/I **79**  
PFS Write/file/plan C/A/I **89**  
Type Tutor III C/A/I **35**  
dBase II/III A/I **325/460**

### ENTERTAINMENT

PHI BEATH PHILER C/A/I **Call**  
Mind Prober C/A/I **30**  
Mad Spy vs. Spy C/A/I **25**  
Your New Baby C/A/I **29**  
Kermits Story Maker C/A/I **23**  
Think Tank C/A/I **Call**  
Bridge C64 **Call**  
Bank Street Writer C/A/I **Call**  
Lode Runner C/A/I **Call**

### UTILITY

Side Kick **Call**  
Norton Utilities **Call**  
Copy 11 PC IBM Install Lotus dBase etc. on hard disk **Call**  
Print shop C/A/I **Call**

### EDUCATIONAL

SAT Math & English C/A/I **Call**  
Agent USA **Call**  
Math Blaster Davidson C/A/I **34**  
Ward Attack, Davidson C/A/I **34**  
Story Machine, Spinnaker C/A/I **22**  
Rockey Boots C/A/I **22**  
Flight Simulator C/A/I **Call**  
Solo Flight C/A/I **26.50**  
F-15 Strike Eagle C/A/I **26.50**  
Hitchhikers guide to the galaxy **Call**

### MICROSOFT

Multimate/Multiplan C/L **320/125**  
Word with mouse/Chart **175/325**  
Spot Light Software Arts I **120**  
Get Organ. Elec. Arts I **135**  
Word Star Propack 4 Prog. A/I **295**  
VMM Pascall C64/+Pet **95**

We carry full software lines by Electronic Arts, Scholastic, Scarborough, PFS and Spinnaker. Batteries included. Others if you don't see it here **Call**

## DISCS & ACCESSORIES

Price for 5 1/4" disk

JM	SS	DS	AT
QTY. SS/DD DS/DD 96TPI 96TPI HDENS			
100 1.47 1.96 2.22 2.75	Call		
100 1.50 2.00 2.26 2.80	Call		
10 1.53 2.04 2.31 2.86	Call		

### VERBATIM

QTY.	SS/DD	DS/DD	96TPI	96TPI	HDENS
200	1.81	2.17	2.72	3.62	4.00
100	1.84	2.21	2.77	3.70	4.09
10	1.88	2.26	2.83	3.77	4.17

### MAXELL

QTY.	SS/DD	DS/DD	96TPI	96TPI	HDENS
200	1.88	2.49	2.71	3.38	5.04
100	1.92	2.54	2.76	3.46	5.15
10	1.96	2.59	2.82	3.53	5.25

### AB's OWN DISKETTES

Over 40% off our regular low price! 50 quality ds/dd diskettes packaged in an Amaray Media Mate 5. **Only 72**

### DISK STORAGE

Mini Flip N File (50 5" disks) **17.45**  
Rolltop 100 (00 disk, 10 div.) **28.95**  
Mini Kas-ette/ 10 (for 5" disks) **1/2.25 10/2.05 ea**  
Amaray Mediamate 5 **9.95**  
Innovative Concepts - fold out style for 5" disks  
Flip N File/25 **16.50**  
Flip N File/50 **22.95**  
PLUS - "Head" disk cleaning kit **11.98**  
W/2 Disks **22.50**  
IBM drive analyzer (Verbatim) **22.50**

**ORDERING INFORMATION:** Order by check, Mastercard or VISA. Personal checks take 15 days to clear, no waiting on certified checks or money orders. Add 3% shipping and handling on all orders (minimum \$2.00) Mail, APO/FPO. Air may require additional charges. PA residents add 6%

sales tax. MA residents add 5%. All items subject to availability. Prices subject to changes. Additional discounts available to qualified educational institutions. Requests for bid on volume requirements invited.

## COMMUNICATIONS

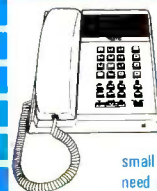

Everyone knows that phones & computers are coming together. While evaluating a data phone we were so impressed with a unit we wish to share it with you! Perfect for a small company. Great if you just need one for home. So many features... can't list them all. 2 lines/8 ext. intercom, no ksu, loop installation, PBX Compatible etc. with door speakers & built in modem coming. First phone **276**  
Mark X Auto Dial/Auto Answer **119**  
Anchor 1200 Baud Hayes Comp. **190**  
Hayes SmartModem 1200B **419**  
Smartcomm II Software **489**  
Hayes SmartModem 1200/300 **489**  
"Crosstalk" software **135**  
Koala Pad (w/software) **Call**  
Koala Muppet Learning Keys **Call**  
4164 Chip Kit Memory for IBM 64K **24**  
Interface cables 6, 10, 12, ft. all popular connectors (Dealer inquiries invited) IBM Printer special **15**

### TECHNICAL BREAKTHRU

Cermetek Security Modem  
3 Levels Hayes Comp. **480**  
1200 Hayes Comp. **380**  
1200 PC addin **320**

## POWER DEVICES

Datashield back-up power source  
200 PC-200 watt **265.00**  
300 XT-300 watt **390.00**  
Brooks 6 Outlet - Surge Suppressor/  
Noise Filter **54.00**  
Computer Power Inc. -500 VA **1320.00**  
Tripp Lite 425 VA 1000 VA **390.00**

### PANASONIC

Panasonic KXP 1090 **239**  
with IBM cable, Friction & tractor Software disk for IBM to change type size & style **Reg. List 430 NDW 265**

Inquiry 7

# AB Computers

THE VALUE LEADER SINCE 1976

252 BETHLEHEM PIKE, COLMAR, PENNSYLVANIA 18915

Use our TOLL-FREE ORDER Line Mon.-Sat. 9am-6pm EST

**800-822-1211**  
In PA: 215-822-7727

Customer Service **215-822-7727**

# INSIDE AN EXPERT SYSTEM

BY BEVERLY A. THOMPSON AND WILLIAM A. THOMPSON

*From index cards to Pascal program*

AN EXPERT SYSTEM will allow anyone with some expertise to create an outline of the process used to solve a particular problem. This outline can be used to generate a series of questions that lead a nonexpert through the solution of similar problems. Many different techniques are used to represent an outline of expert knowledge. One method currently employed is the use of IF...THEN sentences, called rules, to make factual statements about the problem area.

In this article we will describe one way that an expert system can use a set of rules to conduct a consultation session. We will describe the mechanics of how an expert system operates by creating a "cardboard inference engine," and we'll then examine some of the programming considerations for translating the cardboard system into Pascal.

Before we begin describing how rules are used in an expert system, we should get a clearer idea of where the rules come from and the structure that they represent. Imagine for a moment that you are an expert in the field of botany, and you have just received a phone call from a woman who wants your help in identifying the botanical family of a plant that she has found. Since you can't see the specimen, you must rely on information supplied by the caller. However, since she is not an expert, it is very difficult for her to know what information will help you to make the identification. You will have to ask questions in order to get the caller to supply the facts you need to solve the problem.

Let's assume that you have asked enough questions to determine that the plant in question is a tree that belongs to the botanical class gymnosperm. Figure 1 shows one

possible decision procedure that can complete the possibilities in this case. In table 1, rules 1 through 4, you can see how the diagram shown in figure 1 is represented as rules using IF...THEN statements. The set of rules in table 1 and the information in table 2 comprise an incomplete botanical knowledge base that we will use to answer questions about plant type (herb, vine, shrub, or tree), class of tree (angiosperm or gymnosperm), and family of gymnosperm (cypress, bald cypress, or pine). Because we are using an incomplete knowledge base, we can ask well-formed questions that the system cannot answer (e.g., family membership of a vine). Nonetheless, we believe that our simple example will give you some insight into what an expert system is and how it works.

## THE KNOWLEDGE BASE

It is important to understand that knowledge is not a random collection of facts but a collection of facts related by some overall structure. In the example above, the IF...THEN rules provide that structure. The collection of facts used to capture all of the information in a problem area is called the knowledge base. In the system we will present, the knowledge base consists of three main elements—rules, prompts, and translations.

Each rule in table 1 is made up of a conditional part, which is preceded by the word "IF" and a conclusion part.

*(continued)*

Beverly and William Thompson (RD 2, Box 430, Nassau, NY 12123) are the founders of MicroExpert Systems, a company specializing in artificial-intelligence tools for microcomputers. In addition to writing the MicroExpert System program, they are writing a book on expert systems that will be available soon.



which is preceded by the word "THEN." Each clause within these parts is made up of an attribute, which is a keyword or phrase that is some quality about which we are seeking information; a value, which is assigned to an attribute either as a response to a question or a conclusion to a rule; and a predicate (the word "IS" in our system), which relates the two.

Since one of the tasks of the system is to ask the caller to supply information about some of the attributes, the questions to be asked (the prompts) will have to be stored in the knowledge base. The attributes TYPE, FAMILY, and CLASS do not have questions associated with them because the user is never expected to supply any information about them.

Another item associated with the attribute is the translation. This is used to expand the keyword to make the rules more readable. There are two different ways to form translations. The following example illustrates the first of these:

Attribute: STEM

Translation: The stem of the plant

Attribute: TYPE

Translation: The type of the plant

Rule without translation: IF STEM IS GREEN THEN TYPE IS HERB.

Rule with translation: If the stem of the plant is green, then the type of the plant is herb.

When forming a translation of this type, you must keep in mind that whatever phrase is chosen will be directly substituted for the attribute. The predicate and value will remain exactly as they appear in the untranslated rule.

If the method above is used when the value of an attribute is YES or NO, the resulting phrase is very unnatural. We can get around this problem as follows:

Attribute: BROAD AND FLAT

Translation: The shape of the leaves is /not/ broad and flat

Rule without translation: IF TYPE IS TREE AND BROAD AND

FLAT IS YES THEN CLASS IS ANGIOSPERM.

Rule with translation: If the type of plant is tree and the shape of the leaves is broad and flat, then the class of the tree is angiosperm.

If the value had been NO, the clause would have read "the shape of the leaves is not broad and flat." Since the predicate and value are already contained in the translation, they are not restated after the translation.

### THE CARDBOARD INFERENCE ENGINE

Now that we have described all of the items in the knowledge base, we are ready to construct our cardboard inference engine. To make it easy to manipulate the individual items in the knowledge base, let's think of each rule as being placed on a separate index card. Since both prompts and translations are associated with the individual attributes, we can also make an index card for each attribute that lists the keyword, the translation, and the prompt, if there is one. The rules in our knowledge base are shown in table 1; the complete set of attribute cards is shown in table 2. At this point it may be helpful to actually make this set of cards. The step numbers listed in the description that follows refer to the sample session shown in table 3.

### THE GOAL STACK

With our knowledge base completed we can use our cards to guide us through a consultation. The first step in any consultation is to choose a goal for the session (step 1). In this example we will make FAMILY the final goal of our consultation. To begin we should set aside the attribute card for FAMILY on a separate pile called the goal stack. The attribute that appears on the top of the goal stack is called the current goal.

### THE CONTEXT STACK

As we proceed in the consultation, we must keep track of all the facts that we discover. When an attribute is as-

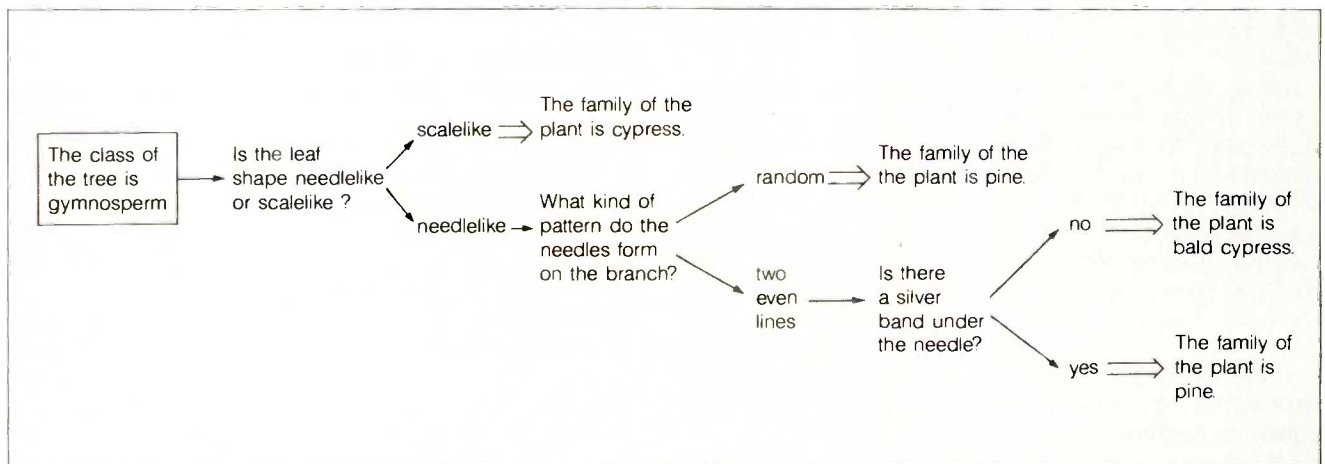

Figure 1: A flow diagram for determining the family of a gymnosperm tree.

Table 1: The rules for the sample botany expert system.

- 1 IF CLASS IS GYMNOSPERM  
AND LEAF SHAPE IS SCALELIKE  
THEN FAMILY IS CYPRESS .
- 2 IF CLASS IS GYMNOSPERM  
AND LEAF SHAPE IS NEEDLELIKE  
AND PATTERN IS RANDOM  
THEN FAMILY IS PINE .
- 3 IF CLASS IS GYMNOSPERM  
AND LEAF SHAPE IS NEEDLELIKE  
AND PATTERN IS 2 EVEN LINES  
AND SILVERY BAND IS YES  
THEN FAMILY IS PINE .
- 4 IF CLASS IS GYMNOSPERM  
AND LEAF SHAPE IS NEEDLELIKE  
AND PATTERN IS 2 EVEN LINES  
AND SILVERY BAND IS NO  
THEN FAMILY IS BALD CYPRESS .
- 5 IF TYPE IS TREE  
AND BROAD AND FLAT IS YES  
THEN CLASS IS ANGIOSPERM .
- 6 IF TYPE IS TREE  
AND BROAD AND FLAT IS NO  
THEN CLASS IS GYMNOSPERM .
- 7 IF STEM IS GREEN  
THEN TYPE IS HERB .
- 8 IF STEM IS WOODY  
AND POSITION IS CREEPING  
THEN TYPE IS VINE .
- 9 IF STEM IS WOODY  
AND POSITION IS UPRIGHT  
AND ONE MAIN TRUNK IS YES  
THEN TYPE IS TREE .
- 10 IF STEM IS WOODY  
AND POSITION IS UPRIGHT  
AND ONE MAIN TRUNK IS NO  
THEN TYPE IS SHRUB .

Table 2: The set of attribute cards for the botany expert system. The attributes are in capital letters, followed by their translations and the appropriate prompt.

- CARD 1 STEM  
the stem of the plant  
Is the stem of the plant woody or green?
- CARD 2 POSITION  
the position of the stem  
Is the position of the stem upright or creeping ?
- CARD 3 ONE MAIN TRUNK  
the plant does /not/ have one main trunk.  
Does the plant have one main trunk ?
- CARD 4 TYPE OF PLANT  
The type of plant
- CARD 5 BROAD AND FLAT  
the shape of the leaves is /not/ broad and flat  
Is the shape of the leaves broad and flat ?
- CARD 6 CLASS  
The class of the tree
- CARD 7 LEAF SHAPE  
the leaf shape  
Is the leaf shape needlelike or scalelike ?
- CARD 8 NEEDLE PATTERN  
the pattern the needles form along the branch  
Is the pattern that the needles form along the branch a random one or are the needles in 2 even lines ?
- CARD 9 SILVER BANDS  
there is /not/ a silver band under each needle  
Is there a silver band under each needle ?
- CARD 10 FAMILY  
the family of the plant

signed a value we will take its attribute card and place it on a pile called the context stack. Since we must also save the value that is assigned to the attribute, a card containing the value of the attribute must be placed along with the attribute card. We will also need a discard pile for rules that we want to remove from the knowledge base. We are now ready to see how these pieces can be put together to form an inference engine. An inference engine is a method of systematically choosing goals, evaluating rules, and interacting with the user in order to obtain a value for the final goal.

### CHOOSING A RULE TO EVALUATE

First try to find a rule card that gives some information about the current goal attribute in its conclusion part (the statements following the word "THEN" in the rule). This process of searching through the conclusions of rules to solve goals is referred to as backward chaining (also called

goal-driven inference or consequent reasoning). If you find a rule that contains the attributes of the current goal in its conclusion, you can go on to "Evaluating the Rule"; otherwise, you will have to resort to the procedure described in the section "Asking the Caller for Information."

### EVALUATING THE RULE

Once we have chosen a rule to evaluate, we must compare the statements in the condition part of the rule, one by one, with the facts that are already known. These facts are contained on the context stack. As we make this comparison we will discover that one of three possibilities can occur:

1. *Evaluating an unknown rule:* The value of a rule is unknown when one or more condition clauses in the current rule do not appear on the context stack (as with rule 1 in step

(continued)



2 of our example shown in table 3). Before this rule can be successfully evaluated the unknown information must be discovered, so the attribute card listing the first unknown attribute (CLASS in our example) will be placed on the goal list along with the rule card containing the unknown rule. The goals that go on the goal list after the final goal are sometimes referred to as subgoals. Return to "Choosing a Rule to Evaluate" and try to find a rule with CLASS in its conclusion.

2. *Evaluating a false rule:* A rule is false when one of the statements on the card has a clause that is contradicted by a fact on the context stack (in step 6, rule 7 has the value GREEN for the attribute STEM, which was contradicted by the user input). In this case, the current rule card is placed on the discard pile, and you must return to "Choosing a Rule to Evaluate."

3. *Evaluating true rules:* A rule is said to be true when each of the clauses in the condition part of the rule matches an item on the context stack (rule 9 was established as true in step 12). When all of the clauses in the condition part are true, the statements in the conclusion part must also be true. Since this rule was chosen to be evaluated because it contained the current goal as its conclusion, you should remove the current goal from the top of the goal stack and place it on the context list. The rule card left behind on the goal stack (rule 5 in our example) should be returned to the top of the rule card pile so it can be reevaluated. The rule card we have just evaluated (rule 9) is kept with the attribute card on the context list to show the value of the attribute and how it was reached. This rule card will also be used to answer questions that the caller may later ask about this conclusion. If there are no other goals on the goal stack, the problem has been

solved. If there are goals remaining, return to "Choosing a Rule to Evaluate."

**ASKING THE CALLER FOR INFORMATION**

In the event that no rule can be found that can provide information about the current goal, you must turn to the caller to help provide the necessary information (in step 5, we ask the caller for information because none of the rules have STEM in their conclusion). This is where we make use of the prompts that have been placed on the attribute cards. Unfortunately, if no prompt appears on the card, it means that the caller can provide no information about the attribute in question. In this case, we have reached a dead end and will have to end the consultation without finding a solution to the problem. If this occurs, there is either some problem with our rules or this branch of the knowledge base was left unresolved.

When a prompt does appear on the current goal card, we use it to question the caller. Once the caller has supplied the missing information, we can remove the current goal card from the goal stack and place it on the context stack. If there is a rule card with this goal, it should be placed on the top of the pile of rule cards. You will also have to make a card that lists the value and place it on the context stack with the attribute card. Once this has been done we can return to "Choosing a Rule to Evaluate."

**WHY AND HOW**

In the course of a consultation it is not uncommon for the caller to want to know why you are asking a certain question. In table 3, step 13, we were unable to find a rule that gave any information about BROAD AND FLAT, so

*(continued)*

Table 3: A step-by-step illustration of a cardboard-inference-engine consultation, showing stack volatilities.

step	evaluate rule#	value of rule	response to prompt	goal stack		context stack		rule#	discard rule#
				attribute	rule#	attribute	value		
1				FAMILY					
2	1	unknown		CLASS	1				
3	5	unknown		TYPE	5				
4	7	unknown		STEM	7				
5	no		WOODY	TYPE	5	STEM	WOODY		
6	7	false							7
7	8	unknown		POSITION	8				
8	no		UPRIGHT	TYPE	5	POSITION	UPRIGHT		
9	8	false							8
10	9	unknown		MAIN TRUNK	9				
11	no		YES	TYPE	5	MAIN TRUNK	YES		
12	9	true		CLASS	1	TYPE	TREE	9	
13	5	unknown		BROAD+FLAT	5				
14	no		NO	CLASS	1	BROAD+FLAT	NO		
15	5	false							5
16	6	true		FAMILY		CLASS	GYMNOSPERM	6	
17	1	unknown		LEAF SHAPE	1				
18	no		SCALELIKE	FAMILY		LEAF SHAPE	SCALELIKE		
19	1	true				FAMILY	CYPRESS	1	

# WordPerfect is just that.

PC World

At SSI, we face a monumental challenge; living up to the name we gave our word processing software. After all, with a name like WordPerfect, the product had better measure up. Obviously it's doing just that. For good reason.

## Simplicity.

Most WordPerfect functions require only one keystroke, a simple press of a finger. And comprehensive, well-written documentation makes learning a breeze.

## Speed.

With WordPerfect's document orientation, you never have to wait between pages of

text. No matter how fast you type, WordPerfect won't slow you down.

## Features.

In addition to standard word processing functions, WordPerfect includes several comprehensive, useful features not found on many word processors. Like a 100,000-word phonetic dictionary; multi-page footnoting capability; table of contents and index generation; automatic outlining and paragraph numbering; and a network version of WordPerfect.

There is very little this program WordPerfect can't do."

InfoWorld

even a beginner can soon master WordPerfect's most difficult functions, such as

PC World

Get the word processor that's living up to its name. WordPerfect. For more information, see your dealer.

Or call or write:

SSI Software  
288 West Center Street  
Orem, Utah 84057  
Information: (801) 224-4000  
Order Desk: 1-800-321-4566,  
Toll-free



**SSI Software**  
Reaching for perfection.



we have just asked the caller the prompt for BROAD AND FLAT. Before answering, the caller asks why we have asked this particular question. To find the reason we need look no further than the top rule on the goal stack. The reason we are trying to find a value for BROAD AND FLAT is to get one of the pieces of information needed to solve the goal CLASS in rule 5. By fitting the information from the goal stack into the following form we will answer the question "Why?":

*We are trying to find a value for the class of the tree.  
We already know that the type of the plant is tree.  
If we can show that the leaf shape is not broad and flat  
then we will know that the class of the tree is gymnosperm.*

Notice that we have substituted the translation for each attribute to make the information more readable.

If the caller now wants to know "Why is CLASS important?" the process is repeated, moving back another item in the goal stack. This can continue until all of the subgoals on the stack are exhausted.

Returning to the example above, the caller may now be satisfied with why you have asked about BROAD AND FLAT but may ask, "How do you know that the type of the plant is tree?" This question can be answered by find-

ing where that attribute appears on the context stack. If there is a rule card with the attribute card, the rule on that card caused the value to be placed on the context stack. To answer the question, we would use the information in the rule to form our response:

the type of the plant is tree  
*was proven using rule 9*  
*This rule states that:*  
If the stem of the plant is woody  
and the position of the stem is upright  
and the plant does have one main trunk  
then the type of the plant is tree.

When no rule card is placed with the attribute card on the context stack, we can inform the caller that he or she must have supplied the fact in response to a prompt.

Allowing a caller to interrupt a consultation to ask how and why makes the process more understandable and more educational to both consultant and caller.

Now that we have made a mechanical model that contains all of the pieces of our expert system, it is a fairly straightforward task to lay out program structures to automate the process. We can now introduce some Pascal

(continued)

FOR THE BEST OF US . . .

**THE CYPHER™**

**A COMPLETE 68000 & Z 80  
SINGLE BOARD COMPUTER SYSTEM  
WITH ULTRA-HIGH-RES GRAPHICS!!**

**FREE  
68000 FORTH  
AND  
CYPHER-DOS**

**FREE  
68000 FORTH  
AND  
CYPHER-DOS**



- 68000 & Z80 DUAL PROCESSORS (BEST OF BOTH WORLDS!)
- 256K to 1 MEGABYTE MEMORY (4164 OR 41256 DRAM)
- DOUBLE DENSITY FLOPPY DISK CONTROLLER (8" 5 1/4" OR 3 1/2" WD 2793)
- DMA CONTROLLER FOR FAST IMAGE TRANSFERS TO/FROM VIDEO MEMORY (INT 8237)
- 2 RS232 SERIAL PORTS (ZSIO)
- 24 BIT ADDRESS MANAGEMENT FOR Z80
- 4 LAYER P.C.B. (9 1/4" x 14 3/4")
- RUNS CP-M-80 2.2, CP-M-80 3.0, CP-M-68K
- ULTRA HIGH RESOLUTION GRAPHICS, 128K, PROGRAMMABLE UP TO 1024 x 1024 RESOLUTION (INEC 7220, GREAT FOR CAD SYSTEMS!)
- REAL TIME CLOCK (MULTITASKING CAPABILITY!)
- TWO CHANNELS OF D/A AND A/D, 12 BIT RESOLUTION (MUSIC! ROBOTICS! LAB WORK!)
- 16K TO 64K MONITOR EPROM
- 4K TO 64K STATIC RAM
- PROGRAMMABLE BAUD RATE GENERATOR
- PARALLEL ASCII KEYBOARD INPUT
- FULL 68000 EXPANSION BUS (60 PIN HEADER, BUFFERED)

# IBM COPY PROTECTION

A versatile system that works.

Call ALF first

## 1-800-321-4668

MultiGuard is ALF's new IBM copy protection system. It's reasonably priced, yet offers maximum protection and flexibility. Call the toll-free number above for our pamphlet on copy protection systems. Inside Colorado, call 234-0871.



ALF Products • Denver, CO

<ul style="list-style-type: none"> <li>• MANUAL \$ 20.00</li> <li>• BARE BOARD, EPROMS, Z80 BIOS, 68000 BIOS, Z80 MONITOR, 68000 MONITOR AND UTILITIES \$ 999.95</li> <li>• MINIMUM OPTIONED "CYPHER" WITH 68000/Z80, SERIAL I/O, 128K DRAM, 4K S RAM AND DISK CONTROLLER, ASSEMBLED AND TESTED \$ 1,099.95</li> <li>• PARTS KIT \$ 999.95</li> <li>• COMPLETE "CYPHER" WITH 256K DRAM, 128K VIDEO DRAM, NEG 7220, REAL TIME CLOCK, A/D D/A DISC CONTROLLER, SERIAL I/O, ASSEMBLED AND TESTED \$1,499.95</li> <li>• PARTS KIT \$1,379.95</li> <li>• KEYBOARD \$ 94.95</li> <li>• SWITCHING POWER SUPPLY \$ 154.95</li> <li>• CASE \$ 94.95</li> <li>• HARD DISC INTERFACE PLUG-IN CARD \$ 125.00</li> </ul>	<p style="text-align: center;"><b>MOTOROLA INTEL</b></p> <p style="text-align: center;"><b>MOTEL COMPUTERS LIMITED</b> 174 BETTY ANN DRIVE, WILLOWDALE, TORONTO, ONTARIO, CANADA M2N 1X6 (416) 221-2340</p>
---	---

ALL PRICES ARE IN U.S. DOLLARS  
SHIPPING: 8% SHIPPING, EXCESS WILL BE REFUNDED  
DELIVERY WILL BE MADE APPROXIMATELY 3 TO 5 WEEKS AFTER WE RECEIVE YOUR ORDER (VISA, MC, CASH)  
PRICES SUBJECT TO CHANGE WITHOUT NOTICE  
CP-M IS A TRADEMARK OF DIGITAL RESEARCH

# Gifford's Multiuser Concurrent DOS.<sup>™</sup> The net that works!



## Gifford nets a big one: Simplicity.

If you've gone through the ordeal of typing as many as seven commands just to get on and off a network, Gifford has your number.

A single, menu-driven network command handles all your network options. Everything you need is right in front of you. The net effect is simplicity — and sanity.

If you'd like to see how Gifford's Multiuser Concurrent DOS can solve your networking problems, or if you'd like to know about Gifford's selection of multiuser systems and software options, call (415) 895-0798.

Or write us at the address below. We'll send you a free networking brochure and give you the name of the nearest dealer.

Multiuser Concurrent DOS is a trademark of Gifford Computer Systems. Concurrent DOS is a trademark of Digital Research, Inc. ARCNET is a trademark of Datapoint Corporation. IBM PC-XT is a registered trademark of IBM Corporation. CompuPro is a registered trademark of CompuPro Corporation. Lotus 1-2-3 is a trademark of Lotus Development Corp. Virtual Terminals is a trademark of Gifford Computer Systems.

## **G** GIFFORD COMPUTER SYSTEMS

A subsidiary of Zitel Corporation

2446 Verna Court  
San Leandro, CA 94577  
(415) 895-0798 TELEEX: 704521  
Houston, TX (713) 680-1944

**THE MULTIUSER COMPANY<sup>™</sup>**

Gifford has the network solution. It's simple, fast, secure, complete, and it works. Multiuser Concurrent DOS is based on Digital Research's Concurrent DOS, the only major microcomputer operating system specifically designed for networking.

Users can share disks and printers transparently, and can also take advantage of true multiuser features like file and record lockout. And Gifford has added a bundle of features that makes Multiuser Concurrent DOS easy to install and use. It lets you get right to work.

### Our net is ARCNET.<sup>™</sup>

Multiuser Concurrent DOS utilizes Datapoint's ARCNET, the most popular network hardware in the industry. It's reliable, economical, and fast — so you can add users without overloading the network.

You can network up to 255 single and multiuser systems. You can connect single or multiuser Gifford or CompuPro<sup>®</sup> systems as well as IBM PC-XTs.<sup>®</sup> Dual processor Gifford and CompuPro systems can run thousands of 8 or 16 bit CP/M or MP/M applications. PC-XTs can run 16 bit CP/M and MP/M programs as well as most popular MS-DOS applications, such as Lotus 1-2-3.<sup>™</sup>

### Gifford adds to your net worth.

Our enhancements of Concurrent DOS make it possible to get more and better work done in less time. Network-wide features include electronic mail, event calendar, inter-terminal communication, user time accounting and usage report generation, telecommunications, user expandable HELP facility,

reminder messages, message of the day, automatic startup and shut-down procedures, and easily prepared files for initializing terminals, printers, and network nodes.

Gifford's Virtual Terminals<sup>™</sup> increase productivity

by offering full-screen concurrency; you can run up to four programs simultaneously from one physical terminal.

### The safety net.

Multiple users can mean multiple security problems. Gifford's security enhancements include

login account names and encrypted passwords to control

access to the system. Users can be further restricted to specified

terminals, user areas, programs, or nodes on the network. You're also safe from

excessive down time, since the modular network architecture gives you immunity from single point failure.

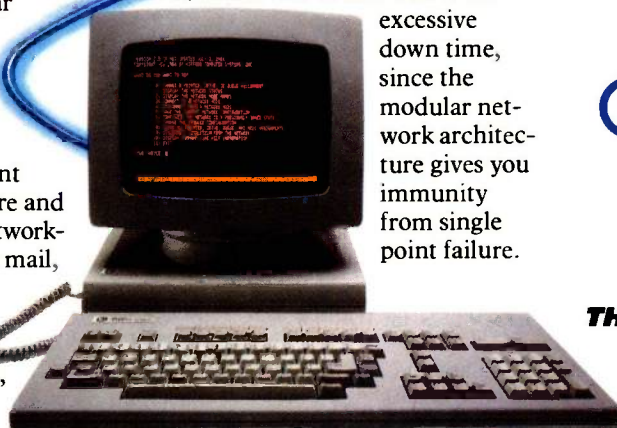



structures to aid in the construction of an expert system.

Conceptually, we can separate the knowledge-base rules and attributes from the inference engine, which employs the knowledge base to reach conclusions. Of course, we could hard-wire the knowledge base into the expert-system program, but then the program would be inflexible. If we wanted to expand the knowledge base to include family-of-vines data or to create a different expert system for insect identification, we would have to rewrite the program. Alternatively, we can make it one of the program's duties to read the rules, prompts, and translations from a file and transform them into a form that can be operated on by the inference engine. This is the approach we will take. The translation is accomplished by means of a *parser*. A parser is a routine that reads statements in a given language and determines whether the statements are legal in that language. As a by-product of its activity, a parser may also produce a transformed representation of the statement for use by other parts of the program. The parser we will discuss is available for downloading from BYTEnet Listings (telephone: (603) 924-9820).

One of the decisions that must be made early in the design of an expert system is the method of entry and storage for the knowledge base. One convenient method is the use of a standard text editor to enter and store the rules, prompts, and translations as ASCII (American Standard Code for Information Interchange) text files. This can lead to difficulties in maintaining the integrity of the knowledge base, but it greatly simplifies the overall program design, since it will not be necessary to write any data-entry routines. In our text file, the rules should have the same form as on our index cards.

### THE PARSER

The language the parser recognizes is described by a grammar. A grammar is a set of definitions that specify how the basic symbols of the language, called tokens, may be legally combined. In this case, a token is any string of characters surrounded by blanks. We can think of the rules, prompts, and translations as statements in a rule language.

The first step in programming a parser is to completely describe the language that the parser will recognize. The Backus-Naur diagram in table 4 describes the grammar that the program must recognize. Backus-Naur form (BNF) is a shorthand for describing syntax. It uses two special symbols: "::=" (read as "is defined to be") and "|" (read as "or"). For example, the first line of table 4,

sentence ::= rule | prompt | translation

is read "a sentence is defined to be a rule, a prompt, or a translation." Names enclosed in quotes must appear exactly as shown. Other symbols are syntactical categories and are defined in the grammar. The phrase

rule ::= rule\_\_number 'IF' condition 'THEN' conclusion '.'

tells us that a rule is made up of a rule number followed by the keyword "IF." This is followed by a condition (to be defined elsewhere in the grammar), the word "THEN," and a conclusion. Finally a "." terminates the rule. The definition of a condition,

condition ::= clause | clause 'AND' condition

tells us that a condition is made up of a clause or a series of clauses connected by the word "AND." A definition such as this is called right-recursive, since it contains the object being defined on the right-hand end of the definition. The recursion in such a definition doesn't necessarily terminate. A condition could legally consist of an infinite number of clauses. Obviously, any program trying to parse such an object would run into problems of time and memory constraints. The BNF gives a good theoretical definition of the grammar but doesn't necessarily contain information about the practical limitations imposed by implementing the grammar on a real computer.

The advantage of using the BNF definition is that it is relatively straightforward to implement a parser for a grammar that has been defined in this manner. The definition provides a guide for the top-down design of the program. You start by assuming the existence of a routine,

*(continued)*

Table 4: The grammar for the expert system's rules, prompts, and translations expressed in BNF.

```
sentence ::= rule | prompt | translation
rule ::= rule__no 'IF' condition 'THEN' conclusion '.'
rule__no ::= digit | digit rule__no
condition ::= clause | clause 'AND' condition
clause ::= attribute predicate value
attribute ::= token | token attribute (max 30 characters)
predicate ::= 'IS'
value ::= token | token value (max 30 characters)
digit ::= '0' . . '9'
token ::= (any string, up to 30 characters, surrounded by blanks)
prompt ::= '@PROMPT' attribute end_of__line text end_of__line '@'
end_of__line ::= (<RET> for UCSD, <RET> <LF> for TURBO)
text ::= (any string, up to 80 characters)
translation ::= '@TRANS' attribute end_of__line text end_of__line '@'
```



# Draw Your Way to the Top

*PC-Draw Will Increase Your Office Productivity.  
And Upward Mobility.*

Imagine. You now have the capability to graphically depict your best ideas, plans, designs and proposals. *In color or black & white.* Accurately. Completely. Dramatically. Concepts presented so forcefully—yet so simply—that you leave that critical meeting with upper management... *totally* confident of success.

And you win. Your secret weapon? PC-Draw. A powerful interactive graphics program for the IBM PC or XT™—*unlike anything else* on the market. Using PC-Draw you create virtually anything that can be drawn with pencil and paper. Quickly. Easily. With far greater detail.

PC-Draw is ideal for presentation graphics, proposals,

**10 DAY  
TRIAL  
PERIOD**

systems design, forms, diagrams... and an endless variety of charts, graphs and illustrations. PC-Draw allows you to produce drawings *up to 99 pages* long. Several templates come with PC-Draw including Flowcharting, Electrical Design, Office Layout, and Alternate Text. In addition you create and store your *own* unlimited supply of user defined symbols.

PC-Draw includes an *easy-to-follow* interactive tutorial. Requires IBM PC or XT™ or compatible, graphics adapter and graphics monitor. Version for PCjr available. Graphic boards, plotters at competitive prices.

Shhh! Don't tell your office competition about PC-Draw. They'll catch on soon enough. For free brochure or to order call 800/2PC-DRAW. In Texas or for customer service call 214/234-1769. Micrografx, Inc., 1701 N. Greenville Ave., Suite 305, Richardson, Texas 75081.

## MICROGRAFX

The Picture of Success.

*(Most popular plotters and printers supported.)*

Inquiry 264





# LIGHTNING SPONGE

## MODEL 22

- Prevents damage to modems, converters and terminals from direct strikes
- Triple stage protection
- Fast response time
- Supports 4 circuits
- Available with lugs or modular jacks, RJ-11

# TELEBYTE

A PUBLIC COMPANY

Remark Division • Telebyte Technology, Inc. 270 E. Pulaski Rd., Greenlawn, NY 11740 • (516) 423-3232 800-835-3298

## INSIDE AN EXPERT SYSTEM

*Many of the procedures that will make up the parser are recursive because their definitions are recursive. This technique is called recursive-descent parsing.*

which we will call scanf, that will read tokens from the input file.

To write the parser, start at the first line of the grammar and write a procedure that can accept a token from a file and decide if it is the starting token of rule, a prompt, or a translation, read the next token, and call the appropriate routine to analyze the rest of the sentence. The procedure sentence in the BYTEnet program does that. The procedure rule in the same program expects to be called with the token having the value "IF". If this is true, it calls condition; if not, it calls the error routine and exits. This process continues, following the BNF, until we get to the procedures attribute, predicate, and value, which will save the items they recognize for later use.

The definition of value uses "AND" as a terminating token, so that attempting to use values such as "hard and woody" will cause the parser to terminate in an error. We could resolve this problem by modifying the definition of rule in the grammar to use some other keyword in place of "AND" or by building some sort of backtracking into the parser. Backtracking would allow the parser to back up to the point in a sentence that caused an error and try an alternate possibility.

All the procedures making up the parser must cooperate by the convention that when they return they will have scanned past all the tokens that they recognize, leaving the first token in the next phrase in the global variable called token.

Many of the procedures that will make up the parser, such as condition and attribute, are recursive because their definitions are recursive. This type of top-down recursive technique is called recursive-descent parsing.

Using this grammar we can mix rules, prompts, and translations together in one file. The rules illustrated in table 1 can be entered as shown. The prompts and translations in table 2 must be changed in order to match the grammar. For example:

```
@trans stem @
The stem of the plant
@
@prompt stem @
Is the stem of the plant woody or green ?
@
```

(continued)

8080  
Z80  
6809

AMX

8086  
8088

### Real-Time Multitasking Executive

- ROMable (< 3K)
- No royalties
- Source code included
- Language interfaces
- Low interrupt overhead
- Inter-task messages

Options:

- C, Pascal, PL/M, Fortran Interfaces
- CP/M-80 BDOS interface
- IBM PC DOS interface
- Extended memory (> 64K)
- Configuration Builder Utility
- Resource Manager
- Buffer Manager
- Integer Math Library
- Real-Time C Library

AMX, AMX86, Real-Time Care TM of KADAK Products Ltd.  
Z80 is TM of Zilog Corp.  
CP/M-80 is TM of Digital Research Corp.  
IBM, PC DOS are TM of IBM Corp.

KADAK Products Ltd.

206-1847 W. Broadway  
Vancouver, B.C., Canada  
V6J1Y5  
Telephone: (604) 734-2796  
Telex: 04-55670

**AMX** (for 8080) **\$800** U.S.  
 (for 6809) **\$950** U.S.  
 (for 8086) **\$950** U.S.  
 Manual only **\$ 75** U.S.  
 (specify processor)

# TeleVideo. The color PC with a black and white price.



Now, brilliant, high resolution color comes standard with the new TeleVideo® Color Personal Computer. At a price that's about the same as the IBM® monochrome system.

In fact, to match TeleVideo's color on an IBM PC, you'd have to add a color monitor, plus a color and graphics adaptor board. And unlike IBM, the TeleColor PC has memory that's dedicated to the color screen. So you get a faster, flickerless image that's easier on your eyes.

What's more, the TeleColor PC also comes with the popular PC™-DOS compatible operating system and three

essential business software programs—word processing, spread sheet and data base management.

It also has standard features that make it easier to use than an IBM PC. Like a tiltable monitor and a keyboard that's exceptionally comfortable to use.

And, of course, the TeleColor PC runs the same popular software as the IBM PC.

Contact the TeleVideo dealer nearest you for a demonstration of the color PC with a black and white price. Call **800-521-4897** (in California, **800-821-3774**).

#### Standard Features

- ▶ Word processing, spread sheet and data base software
- ▶ Color and graphics display
- ▶ 12 inch tilt color screen
- ▶ 256 Kbyte RAM
- ▶ Two 360 Kbyte slim-line floppy disk drives
- ▶ RS-232C serial port
- ▶ Parallel printer port
- ▶ Composite video port
- ▶ Internal expansion bus slot
- ▶ GW BASIC® programming language
- ▶ Self-running demonstration diskette
- ▶ PC-DOS compatible

From the Personal Mini Family of Products.



Systems  
TeleVideo Systems, Inc.

Northwest (408) 971-0255 Southwest (714) 476-0244 Southcentral (214) 258-6776 Midwest (312) 397-5400  
Southeast (404) 447-1231 Mid-Atlantic (703) 556-7764 Northeast (617) 890-3282 East (516) 496-4777 Rocky Mountain (714) 476-0244  
IBM is a registered trademark of International Business Machines. GW BASIC is a registered trademark of MicroSoft Corporation. PC-DOS is a trademark of International Business Machines.



To change the kind of rules recognized by the program, modify the grammar and then, using the new grammar as a guide, rewrite the routines that process the grammar.

A cross-reference program that uses the parser routines described in this article can be downloaded from BYTEnet. The source code is available in a UCSD or Apple Pascal version and a Turbo Pascal version. The set of rules used in this article is also available as a text file as well as a more complete knowledge base that identifies the genera of conifers in the northeast U.S. The cross-reference program will read a knowledge base from a text file and produce an alphabetized list of the attributes along with their translations, prompts, and values. The numbers of the rules containing each value will also be displayed.

While the cross-reference program represents about 16K bytes of source code, it is only part of an expert system. In the rest of this article, we will present the specifications for a full-blown program to implement the cardboard inference engine in Pascal. The specifications are based on a program we wrote called MicroExpert System, which is available on disk from McGraw-Hill for IBM and Apple computers for \$39.95. The package includes full documentation and source code and is a straightforward realization of the complete cardboard inference engine. (MicroExpert is a trademark of MicroExpert Systems.) The cross-reference program on BYTEnet can be used with the MicroExpert program without modification.

## DATA STRUCTURES

Parsing ensures that the rules in the file are well formed, but this is only part of an expert system. The major function of the system is to interpret the rules and find a value

for the goal of the consultation. The rest of the program must be designed to support this function.

Along with parsing the rules, the program must allocate storage for prompts, translations, and rules. For rules it will be necessary not only to store attributes and values but also to represent the overall structure of the rules in a compact manner. Prompt and translation strings must be stored in a way that will allow them to be associated easily with their respective attributes.

There are numerous methods of accomplishing this association. In our system, MicroExpert, we used linked lists of records called *items* to store most of the data elements necessary for the operation of the inference engine. This is slightly wasteful of storage, but it simplifies the overall program design. Listing 1 shows an item as it would be defined in Pascal.

There are two basic kinds of items. The rule item contains the attribute, the value, the rule number, and the kind of item (condition or conclusion). Since in the rule description we have allowed only one kind of predicate, "IS," we have not included the predicate in the item. For each clause in the rule, an item is created. The items making up the clauses in a rule are linked together by means of a pointer. Finally, another pointer is inserted into an array that points to the first item in the rule. This structure is represented in figure 2. Each rule is thus stored in memory as a pair of linked lists, one for the condition and one for the conclusion of the rule.

Prompts and translations are also stored by means of a linked-list organization. When the parser reading the knowledge-base file encounters a prompt or translation, an item is created for the attribute, if one does not already exist. The item is inserted into a linked list of attribute items and, as prompt and translation lines are read, they are also linked together and pointed to by fields in the attribute list. This structure is diagramed in figure 3.

Linked lists are a useful programming mechanism for manipulating symbolic structures such as rules. Unfortunately, languages like Pascal provide few intrinsic routines for handling lists. In order to implement an expert system in Pascal, routines for manipulating lists and managing storage must be designed. Pascal provides intrinsic procedures for manipulating dynamic storage. Unfortunately, these routines vary somewhat among different versions of Pascal. Most versions provide a new procedure to allocate storage, but the method of releasing dynamic data when it is no longer needed differs slightly among the versions of Pascal that we wished to use.

Since we wanted MicroExpert to run under Apple and Turbo Pascal with only minor modifications, we chose not to use the Pascal intrinsic `dispose`, which is not included in the Apple version. Instead we maintain another list of items. When a request is made for a new item, the program first checks this list. If the list is empty, it calls the intrinsic function `new` to get space for the item. If the list is not empty, the top item of the list is returned and the

(continued)

Listing 1: Pascal code to describe an item and related data types.

```

TYPE
  string80 = string[80];
  word = string[word_size];
  counter = 0 .. maxint;
  item__type = (cond,concl);
  item__ptr = ^item;
  string__ptr = ^string__rec;
  string__rec = RECORD
    info : string80;
    next__line : string__ptr;
  END;
  item = RECORD
    next : item__ptr;
    attr : word;
    CASE boolean OF
      TRUE : ( val : word;
              kind : item__type;
              rule__no : counter );
      FALSE : ( prompt__ptr : string__ptr;
               trans__ptr : string__ptr;
               val__ptr : item__ptr );
    END;
  END;

```

# INSIDE AN EXPERT SYSTEM

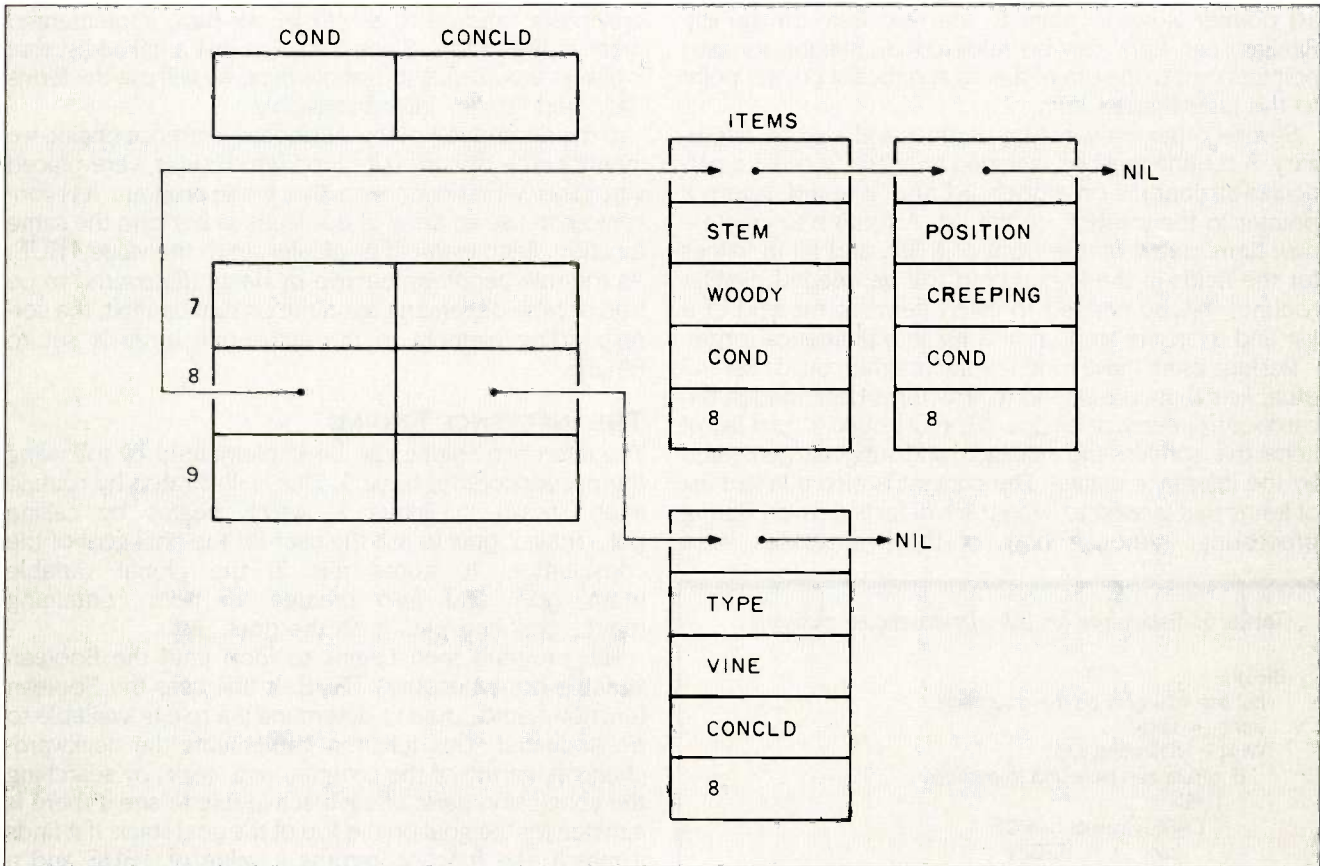

Figure 2: The linked-list representation of rule 8.

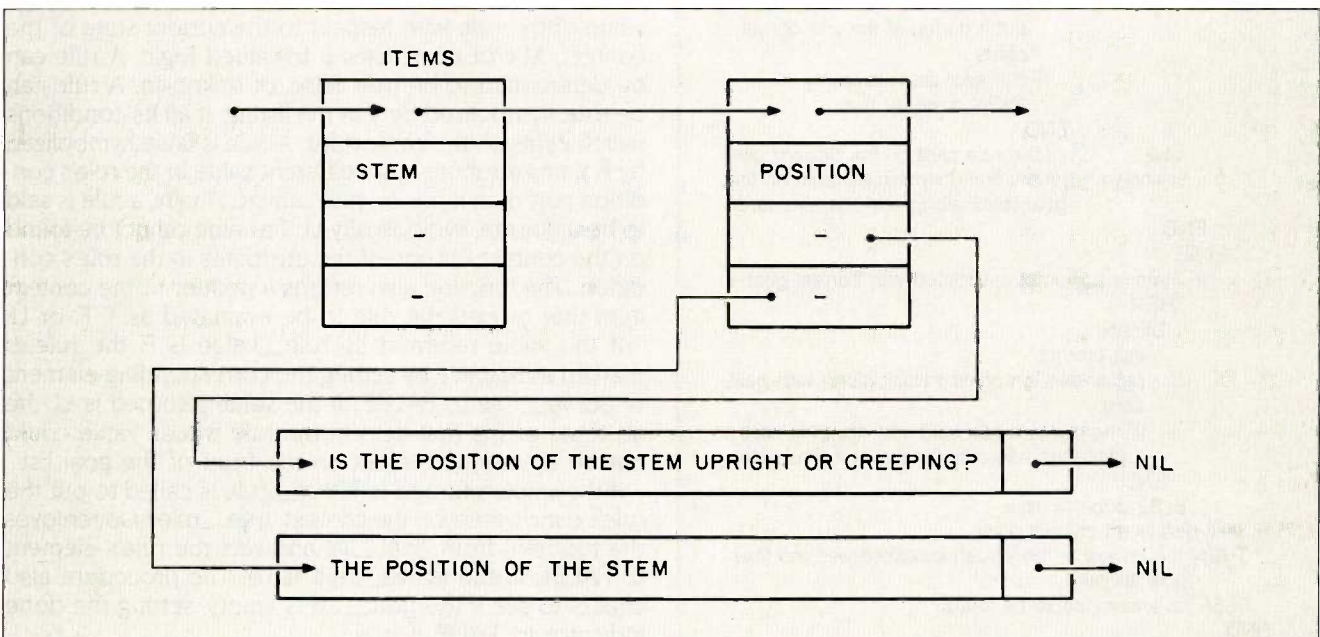

Figure 3: The linkages between the attribute list and the prompt and translation lists are illustrated for the POSITION attribute.



list pointer is set to point to the next item on the list. Similarly, an item can be released by making its next pointer point to the top of the list and the list pointer point to the just-released item.

Several other list-handling routines will also be necessary. A routine must be included to check to see if a particular attribute is on a given list and, if found, return a pointer to the location on the list. A routine to create a new item, put it on the front of a list, and fill in values for the fields in the item record will be needed. Similar routines will be needed to insert items at the end of a list and to insert an item in a list in alphabetical order.

Besides using these routines, the program builds several other lists that correspond to structures described in the cardboard inference engine. We must build a goal list of items that contains the main goal and subgoals generated by the inference engine. The context is also a linked list of items that is used to keep track of facts derived during processing. Although both of these structures were

previously referred to as stacks, we have implemented them as linked lists. Since a stack is just a linked list that is always accessed at its first element, we will use the terms "list" and "stack" interchangeably.

In the description of the cardboard inference engine we mentioned a discard pile upon which rules were placed when they were no longer active. In the program, it is convenient to use an array of Booleans to perform the same function. Each element is initially set to the value TRUE. As the rule becomes inactive by being discovered to be true or false depending upon the current context, the corresponding element in the active-rule array is set to FALSE.

### THE INFERENCE ENGINE

The inference engine can be implemented by following the pseudocode of table 5. This is illustrated by routine `infer`, shown in listing 2, which begins by calling `get_main_goal` to ask the user for the final goal of the consultation. It stores this in the global variable `main_goal` and also creates an item containing `main_goal` and puts it on the `goal_list`.

The program then begins to loop until the Boolean variable `done` becomes TRUE. It first uses the Boolean function `found_rule` to determine if a rule is available to be evaluated. This function implements the backward-chaining feature of the program and works by searching the conclusion parts of each active rule to see if there is a match for the goal on the top of the goal stack. If it finds a match, the function returns a value of TRUE and a pointer to the item in the rule that gave the match.

If a rule containing the current goal could be found, the function `rule_value` is called to determine the logical value of the rule with respect to the current state of the context. MicroExpert uses a tri-valued logic. A rule can be determined to be true, false, or unknown. A rule can be true, symbolized by T in the listing, if all its conditions match items on the context list. A rule is false, symbolized by F, if any attribute has a different value in the rule's condition part than it has on the context. Finally, a rule is said to be unknown, symbolically U, if a value cannot be found on the context for one of the attributes in the rule's condition. The function also returns a pointer to the context item that caused the rule to be evaluated as T, F, or U.

If the value returned by `rule_value` is F, the rule is marked as inactive by setting the corresponding element of `active_rule` to FALSE. If the value returned is U, the attribute of the first item in the rule whose value could not be determined is put on the front of the goal list.

If the value returned is T, `true_rule` is called to put the rule's conclusions on the context; `true_rule` also removes the top item from `goal_list` and sets the rule's element to FALSE in the `active_rule` table. The procedure also checks to see if the `goal_list` is empty, setting the done indicator to TRUE if it is.

If no rule can be found by `found_rule`, the program calls

*(continued)*

Table 5: Pseudocode for the inference-engine procedure.

```
BEGIN
  put the final goal on the goal stack.
  done := false.
  WHILE NOT done DO
    IF a rule can be found to evaluate
      THEN
        CASE value of rule OF
          true      : BEGIN
                        put attribute card from goal stack
                        and the rule card being evaluated
                        on the context stack.
                        IF there was a rule card with the goal
                          put it on top of the pile of rule
                          cards.
                        IF the goal stack is empty
                          THEN done := true.
                        END.
          false     : put the rule card on the discard pile.
          unknown   : put the first unknown attribute on the
                        goal stack along with the rule card.
        END.
      ELSE
        IF there is a prompt associated with current goal
          THEN
            BEGIN
              ask prompt.
              put answer on context stack along with goal
              card.
              IF there was a rule card with the goal card
                place the rule card on top of the rule pile.
            END.
          ELSE done := true.
        IF final goal is on context stack
          THEN the answer is the value associated with the final
              goal attribute.
          ELSE no answer could be found.
        END.
```

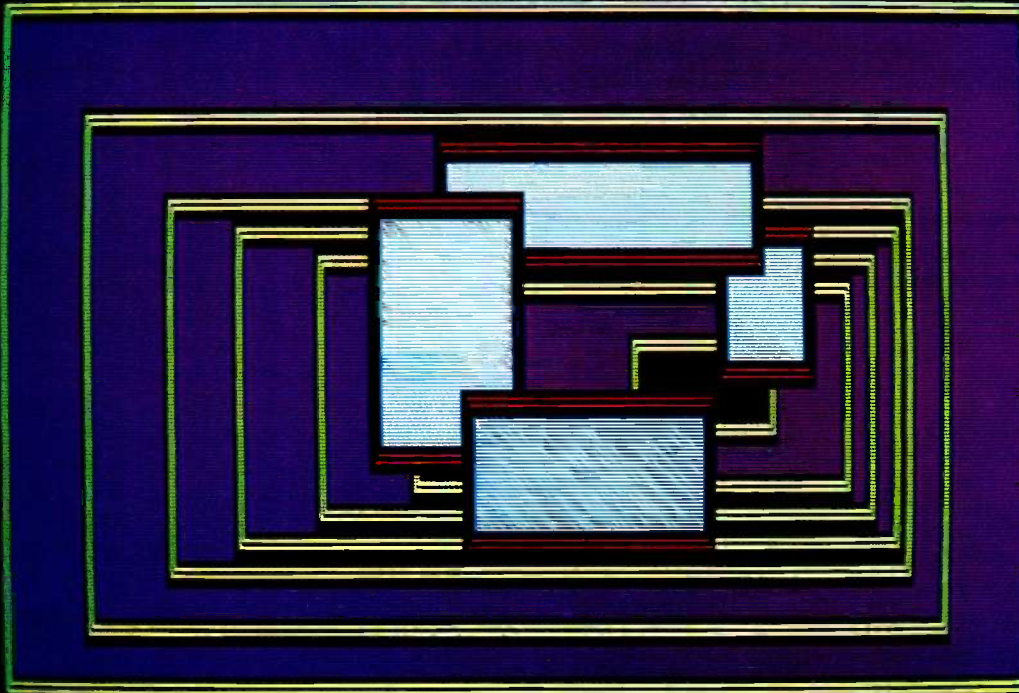

WHEN YOU BUILD A HOUSE... YOU DON'T NEED TO MAKE THE WINDOWS YOURSELF. NOW... THE SAME IS TRUE WHEN YOU'RE WRITING CODE.

### Windows With A View Toward The Future

The Window Machine™ occupies only 12K! Written in tight, fast Assembler, it performs like a racing engine... with more power than you'll probably ever need. Yet, it's an engine designed to fit in the vehicle of your choice... from a "stripped-down" 128K IBM PC to a fully loaded AT. The programs you write today will run on the broadest range of machines possible... now, and in the future.

### Windows Bigger Than Your Screen?

Here's where the VSI part of our name fits in. VSI means Virtual Screen Interface. Behind each window, there's a much bigger picture. VSI defines virtual screens rather than just windows. The window itself shows whatever portion of its virtual screen you wish to exhibit at any given point in your program. Each screen can be up to 128 x 255 (columns x rows, or rows x columns). And there are more than 100 screen primitives at your command.

### Multilingual Windows

You can order The Window Machine with the language interface of your choice: C, Pascal, Compiled Basic, Fortran, Cobol, or PL1. We've even recently completed

These are coders' windows... designed to be built into the programs you are writing. They can overlap, move anywhere on the screen, grow, shrink, vanish or blink. They can be bordered in anything from a simple line to flashing asterisks... or even no border at all. And you can have up to 255 of them at a time! Color or monochrome... of course!

# Why did Simon & Schuster, 3Com, Tymshare, and Revlon choose VSI - The Window Machine?

(and how come you can buy it for such a low price?)

**\$59.95**

an interface for Turbo Pascal\*, so that now true, full-featured windowing can be utilized with this fine compiler. (Turbo's own built-in "windowing" procedure is extremely limited).

### Windows That Won't Break You

We decided to save you a lot of money. So, we left behind fancy binders, monogrammed slip cases and plastic presentation boxes. Instead, you'll find an extremely powerful tool and a 200 page manual written with an eye toward simplicity, clarity and completeness. (We

\*Turbo Pascal is a Trademark of Borland International

figured if you wanted ribbons and bows you could always add them yourself.)

And by offering you the product ourselves, we were able to cut out all the middlemen and save you a tremendous amount of money.

## VSI THE WINDOW MACHINE

Available for the IBM PC, XT, AT, IBM Compatibles, Wang, T.I., and HP 150

### The Window Machine Includes:

- Zoom Windows
- Multiple Virtual Screens (up to 255)
- Choice of Borders (including flashing borders)
- Support for all Color and Monochrome Video Attributes (no graphics card required)
- Built-in Diagnostics
- And much, much more

### ORDER YOUR COPY OF VSI - THE WINDOW MACHINE TODAY

For Visa & MasterCard orders call toll free: 800-538-8157 Ext. 824 In CA 800-672-3470 Ext. 824  
Call Mon.-Fri. 6A.M. to 12P.M., Sat. & Sun. 6A.M. to 8P.M. (P.S.T.)

The Window Machine\* \$59.95 + \$5 Shipping and Handling  
LANGUAGE INTERFACE:

Lattice C  Realia Cobol  Microsoft Basic Compiler  Microsoft Fortran  
 PL1  Microsoft Pascal  Turbo Pascal (full featured true windowing)

COMPUTER \_\_\_\_\_

Name \_\_\_\_\_

Address \_\_\_\_\_

City \_\_\_\_\_ State \_\_\_\_\_ Zip Code \_\_\_\_\_

Check  Money Order  VISA  MasterCard

Card # \_\_\_\_\_ Exp. Date \_\_\_\_\_

\*California residents: tax included. Orders outside USA: Please add \$10 for shipping and handling

30 day Money Back Guarantee

**AMBER**  
AMBER SYSTEMS

1171 S. Saratoga-Sunnyvale Road  
San Jose, CA 95129

B \_\_\_\_\_

AMBER SYSTEMS, INC. 1171 S. Saratoga-Sunnyvale Road, San Jose CA 95129

FOR DEALER INQUIRIES: CALL OUR 800 NUMBER



**Listing 2:** *The procedure infer is a Pascal realization of the pseudocode in table 8.*

```

PROCEDURE infer ;
BEGIN
  get__main__goal ;
  done := false ;
  WHILE NOT done DO
    IF found__rule(ptr)
    THEN
      CASE rule__value(ptr^.rule__no,reason) OF
        T : true__rule ;
        F : active__rule(ptr^.rule__no) := FALSE ;
        U : put__on__goal(reason) ;
      END
    ELSE
      IF found__prompt(attr__list,prmp__ptr)
      THEN
        BEGIN
          why__ptr := goal__list ;
          get__answer ;
        END
      ELSE done := TRUE ;
    END ;
  what ;
  IF NOT on__list(main__goal,context,ptr)
  THEN writeln('No value could be found for ',main__goal) ;
  END ; (* infer *)

```

the function found\_\_prompt to search the attribute list for a question to ask the user in order to get a value for the goal. The function returns a value of TRUE and a pointer to the matching element in the attribute list if the attribute has a prompt associated with it.

If a prompt cannot be found, the done indicator is set to TRUE and the loop terminates. This usually indicates some kind of inconsistency in the rule base, and the interpreter will terminate without finding a value for the main goal. If a prompt was returned, get\_\_answer is called to display the prompt and get a value for the goal attribute from the user.

The program continues in this manner, searching for rules to evaluate and, when necessary, asking the user for information, until either the goal list is exhausted or no prompt can be found. The program then calls what to print out the contents of the context and finally checks the context list and prints a message if the main goal is not on the context.

### IMPLEMENTING WHY AND HOW

In response to the user query "why," the program prints out the goal pointed to by why\_\_ptr, which infer initially set to point to the current goal. It also prints the translated rule that caused the goal to be placed on the goal list. The rule number for this rule was stored in the goal item when the item was created by put\_\_on\_\_goal; why\_\_ptr is then updated to point to the next goal on the list, so that successive responses of "why" will print the contents of goal\_\_list and the rules examined by the system in establishing the goals.

When a rule is printed, each clause is given a number, and an item for the clause is added to a list. This list is used in conjunction with the response "how." The user may respond to the prompt by typing "how" followed by a number. The number is the number of a line printed in response to the last "why."

For example, the phrase "how 3" is interpreted as "How was or can the phrase on line 3 be proven?" In response to this phrase, the program searches the context list for a match for the attribute of the phrase in question. If a match is found, the value in the phrase is compared to the corresponding value on the context. If these values match, the program prints the rule that placed the item on the context. If this rule number is 0, the program prints that the phrase was proven by user input.

Not finding the attribute from the phrase on the context indicates the logical value of the phrase has not yet been determined. In this case, the conclusion parts of the rules are searched for a match for the attribute in the phrase. If a match is found, the rule number of the matching rule is printed. If no match can be found, a message is printed indicating that the phrase can be determined only by user input.

### VARIATIONS ON A THEME

The system we have described and our MicroExpert program are both designed for people who want to experiment with expert systems. What we have tried to provide is the bare bones of an expert system, with enough modularity and openness of design to encourage modification and experimentation. As a conclusion to our article, we would like to suggest some possible directions for variation in the design that we have presented.

As we mentioned, the structure of inference on the card-board system is backward chaining. An equally valid method of inference is the forward-chaining or data-driven engine. In this method, at any point during the consultation, the system searches the condition parts of the rules for any rule that may be true and performs their conclusion part. This adds new information to the context, and the process is repeated.

Methods can also be designed that are combinations of the two types of inference. As described, we put only the conclusion of the current rule on the context, i.e., the rule that produced the current goal. Finding a value for this goal may cause other rules to become true, but the system will ignore them. A relatively simple modification would be to search the rule base for all rules that have the current goal in their conditions and evaluate them. If any of these rules add items to the context, repeat the process until no new items are added.

Another useful modification to the inference engine would be the inclusion of new predicates such as "IS NOT" and numerical operators such as "+," "-", "\*", and "/." These predicates would allow more complex relationships among attributes but will also increase the complexity of the function that evaluates the rules. ■

Okay, okay, okay. If you're going to insist on specifics, we can tell you outright that The Shoebox Accountant retails for \$395. We realize we can probably disclose this detail without appearing too pretentious, simply not mentioning that for this incredibly marketable price, The Shoebox Accountant offers a totally integrated small business accounting system, complete with tutorial, queuing files, and CYMA's powerful reporting capabilities, and capsulizes the complete system on a single diskette. After all, as our professional peers, you're entitled to a little inside information. But you know us: subtlety is our hallmark.

Nice Box.  
Fully Integrated.  
\$395.









# COMPLETE IBM™ PC SYSTEMS

## IBM PC BASE SYSTEM IBM PC w/256K

**\$1,497.00\*** (32.55)

Floppy Drive Controller  
2 Double Sided Double Density 320/360K Disk Drives  
The Base System is your lowest cost starting point for configuring the exact system of your choice. Combine it with any of the monitors, video cards, multifunction cards and accessories listed in this ad, and prove the Network can't be beat as your system source.

## IBM PC PROFESSIONAL HARD DISK SYSTEM IBM PC w/256K

**\$1,974.50\*** (42.87)

Floppy Drive Controller  
1 Double Sided Double Density 320/360K Disk Drive  
w/Half Height Disk Subsystem.  
Half Height 10MB Drive Allows Room  
for Addition of Tape Backup in PC!  
1/2 times faster than XT  
Automatic Hard Disk Boot Feature.

This system increases productivity in any business or professional situation. The 10Mb hard disk eliminates cumbersome floppy disk changes, simplifies operations and dramatically speeds program execution time. The NETWORK's buying power provides you with better than XT performance at a price lower than you'd expect to pay for a standard PC.

\*PC Network Members pay just 8% above this wholesale price plus shipping. These prices have been prepared in February, 1985 and may have been changed with new product announcements. Call for latest prices.

CALL FOR  
LATEST IBM  
ANNOUNCEMENTS  
CUSTOM  
CONFIGURATIONS  
WELCOME

## COMPAQ™ HARD DISK SYSTEM (+)

### PROFESSIONAL PORTABLE HARD DISK SYSTEM COMPAQ w/256K

**\$2,735.00\*** (59.08)

Floppy Drive & Controller  
Integral dual mode monitor  
Shock Mounted 3" 10MB Auto Booting Hard Disk.

PC Network goes the COMPAQ+ one better building a newer technology 1/2 height low power consumption hard disk into the standard COMPAQ. Mounted with a 1/2 height floppy drive in the space of 1 Conventional full height unit, you have expansion available to add up to 2 additional hard disk, tape or floppy drives in your portable, just like the Desk Pro. All for about what you would pay for the standard 2 floppy portable.

## FEATURED PRODUCTS!

**64K MEMORY EXPANSION KITS** ..... \$ 19.98\*  
Set of 9 chips Guaranteed for Life.

**LOTUS 1-2-3** ..... 265.00\*  
New Best Price!

**INTERNAL PC 10MB HARD DISK**..... from 555.00\*  
Low Power Automatic Boot works on standard PC's. Includes drive/controller/cables/mounting hardware & instructions.  
We use our clout with Brand Name suppliers like COGITO/MMI/Tandon/Fujitsu/Miniscribe/Shugart and others to bring you the best products at the Lowest Price in the Business! Call on the brand of your choice.

**1/2 HEIGHT DS/DD DISK DRIVES** ..... per pair from 145.00\* (pr)  
2 drives w/mounting hardware & complete instructions.  
Just like our hard disks featured above. The Network buy's direct and makes fantastic deals with manufacturers like MPI/Tandon/CDC/Shugart/Qume/TEAC and others to bring you fantastic prices and Name Brand drives for your PC/AT/XT or Jr/or Compatible.

**OKIDATA NEW PERSONAL PRINTERS**  
Microline 182/120CPS/IBM Graphics/LQ Mode & More! + More! ..... 200.00\*  
Okimate Color 20 80CPS/100 + Colors/IBM Graphics  
LQ Mode + More! (Needs Interface) ..... 109.00\*

**TANDON TM100-2 OR CDC FULL HEIGHT DRIVE** ..... 105.00\*  
**EVEREX MAGIC CARD/OK** ..... 170.00\*

Full six Pack Features—Game Port included Extra Software.  
**AMDEK V310A IBM TTL AMBER** ..... 130.00\*

**STB GRAPHIX PLUS II** ..... 235.00\*  
Both Mono and Color Card w/printer port. Run either Monitor type or both at once!  
Gives 16 Colors w/Lotus.

**HERCULES COLOR CARD w/Printer Port** ..... 148.00\*

**HAYES 1200B with new Smartcom II/VT100 Emulator** ..... 325.92\*

**BRAND NAME DISKETTES** ..... 14.00\*  
DS/DD Box of 10 Guaranteed for Life Not Generic  
\*NETWORK members pay just 8% above these wholesale prices plus shipping

**CALL TOLL FREE 1-800-621-S-A-V-E** (orders and memberships only)

In Illinois call (312) 280-0002 validation code B345

IBM and COMPAQ are registered trademarks of IBM and COMPAQ corporations.

# PC NETWORK

## ... WITH THESE 15 UNIQUE BENEFITS

**1 COST + 8% PRICING**—The NETWORK purchases millions of dollars in merchandise each month. You benefit in receiving the lowest price available and all at just 8% above published dealer wholesale price.

**2 OUR 600 PAGE WHOLESALE CATALOG**—Members receive our 600 page wholesale catalog containing over 20,000 hardware and software products for the IBM PC, APPLE and over 50 other popular computer systems. **THE NETWORK'S CATALOG IS THE LARGEST SINGLE COMPILATION OF PERSONAL COMPUTER PRODUCTS AVAILABLE TODAY. NOW UPDATED QUARTERLY!**

**3 IN-STOCK INSURED FAST HOME DELIVERY**—The NETWORK maintains a giant multi-million dollar inventory of most popular products, allowing us to ship many orders from stock. Non-stock items are typically maintained in local warehouses just days away from The NETWORK and YOU. We pay all insurance expenses on your shipment. **EMERGENCY OVERNIGHT SERVICE IS AVAILABLE ON REQUEST.**

**4 10 DAY RETURN POLICY**—If you are not satisfied, for any reason with any hardware component purchased from The NETWORK within 10 days of receipt, we will refund your entire purchase (less shipping) with no questions asked.

**5 MEMBERSHIP SATISFACTION GUARANTEE**—If for any reason you are not satisfied with your membership within 30 days, we will refund your dues IN FULL.

**6 EXPERIENCED CONSULTANTS**—The NETWORK hires consultants, not order takers, to aid you in product selection. Our consulting staff possesses in excess of 150 man years of personal computer product experience. **We back our consultants with our money back guarantee: IF ANY PRODUCT RECOMMENDED BY OUR CONSULTING STAFF FAILS TO PERFORM AS PROMISED—WE WILL TAKE IT BACK AT OUR EXPENSE FOR A 100% REFUND.**

**7 FREE TECHNICAL SUPPORT**—The NETWORK supports every product it sells. Our qualified TECH-SUPPORT staff will help you assemble your system, interpret vendor documentation and get your software and hardware to work. **WE WILL GIVE YOU ALL THE HELP YOU NEED, WHEN YOU NEED IT—FREE!**

**8 OPTIONAL BUSINESS RENTAL LIBRARY**—All members can join our BUSINESS RENTAL LIBRARY featuring over 1000 available titles for just \$25 PER YEAR above the base membership fee. This entitles you to rent business software AT JUST 20% of the DISCOUNT PRICE FOR A 14 DAY PERIOD. If you decide to keep the software, the entire rental fee is deducted from the purchase price. **VIP MEMBERS GET A FULL 30 DAYS for just \$30 above the V.I.P. base fee. This also includes the game library privileges for a \$5 combination savings.**

**9 OPTIONAL GAME SOFTWARE RENTAL LIBRARY**—The Game Rental library is available to members for just \$10 PER YEAR and permits evaluation (or just enjoyment) of any game or educational software product as above.

**10 SPECIAL SAVINGS BULLETINS—THE PRINTOUT**—Issued Quarterly at no charge to Network members only! The Printout contains all the New Product listings and price changes you need to keep your Catalog up to date. Also, we buy excess dealer inventories, and store bankruptcy closeouts, which we turn around and make available to our members at fantastic savings via **THE PRINTOUT.**

**11 DISCOUNT BOOK LIBRARY**—Working with numerous publishers and distributors, The NETWORK has assembled a library of over 1000 computer related books and manuals at savings of up to 75% from the normal store price.

**12 MEMBERSHIP REFERRAL BONUS**—Our most valuable source of new members is you! To date almost 40% of our members have been referred by word of mouth from other satisfied members. For those of you who refer new members, The NETWORK will credit a cash bonus to your account applicable to any future purchase.

**13 CORPORATE ACCOUNT PROGRAM**—Almost 50% of The NETWORK's members are corporate buyers and users (see opposite page left). The NETWORK can establish open account status and assign designated account managers to expedite orders, and coordinate multiple location shipments.

**14 QUANTITY DISCOUNTS**—For large corporations, clubs, and repeat or quantity buyers The NETWORK can extend additional single order discounts, when available to us from our manufacturers and distributors.

**15 PRICE PROTECTION**—The PC Industry is crazy!! Prices change not yearly or monthly or even weekly but often day by day!! These changes are sometimes up but are mostly down!! **THE NETWORK GUARANTEES THAT IN THE EVENT OF A PRODUCT PRICE REDUCTION, BETWEEN THE TIME YOU PLACE YOUR ORDER AND THE TIME THE PRODUCT SHIPS YOU WILL ONLY PAY THE LOWER AMOUNT!!**



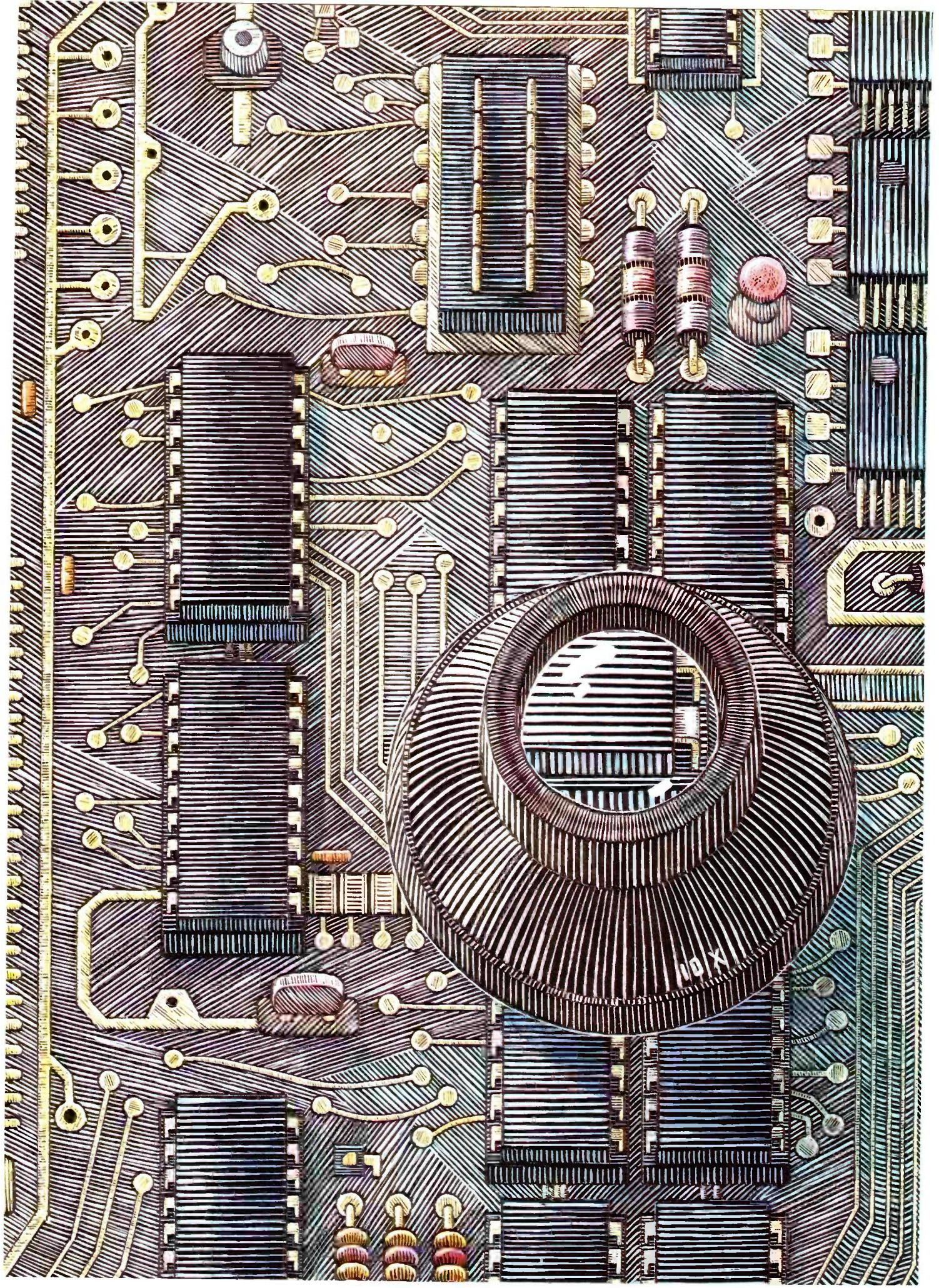



# Reviews

---

<b>REVIEWER'S NOTEBOOK</b>	
<i>by Glenn Hartwig</i> .....	337
<b>THE ITT XTRA</b>	
<i>by John D. Unger</i> .....	338
<b>INSIGHT—A KNOWLEDGE SYSTEM</b>	
<i>by Bruce D'Ambrosio</i> .....	345
<b>REVIEW FEEDBACK</b> .....	348

---

ARTIFICIAL INTELLIGENCE. The phrase seems randomly applied in a wide variety of contexts by a growing number of people from diverse backgrounds. This month's theme section gives you the theories and the potential as viewed by some of the world's most astute observers. "But," you ask yourself, "what can I do with it?" And in order to answer that question satisfactorily you have to know what products are available now, what they can do, and their specific approach to AI. One point you couldn't really get away from until now was the fact that most AI products were specialized and expensive. Building your own knowledge base and using the computer to help you arrive at a solution that neither you nor it knew in advance depended on custom databases and large amounts of computing power. With our first review this month, we see that things may be starting to change.

Insight, from Level 5 Research, sells for \$95, is designed for IBM Personal Computers (PCs) and compatibles, and lets you build your own expert system through goal-outlining procedures and probabilistic reasoning. Reviewer Bruce D'Ambrosio doesn't give it high marks for completeness, but he notes that some of the basic tools are there. For example, while Insight gives you Boolean and numeric data types, it does not give you character data or the capability to structure variables into records or frames. Still, its inability to structure data isn't a major handicap as long as the problems are simple and you use a single kind of data. Mr. D'Ambrosio gives Insight a nod as a possible AI learning aid. Expert-system development tools are beginning to work their way down to the microcomputer level, and Insight is an example of something you can use right now. It's not fully realized in some respects, but it's not a game either.

John Unger takes a look at ITT's entry in the IBM PC-compatible sweepstakes, the XTRA. Mr. Unger notes that while the XTRA may be attractive in a lot of home or office situations, it breaks no technological ground. It uses an 8088 microprocessor at a 5-MHz clock rate, just slightly faster than the IBM PC's 4.77 MHz but not so fast that it can't run most IBM PC applications software. ITT bundles a communications package with the XTRA, which is logical enough when you think about it. Except that not every communications company thought about it. The AT&T 6300, for example, is bereft of communications software. It's an indication that the XTRA's designers and packagers used some forethought. Mr. Unger reports that the XTRA features a number of these design touches, which seem to indicate that the company made an effort to provide a product that can complement, as well as compete with, the IBM PC.

—Glenn Hartwig, *Technical Editor, Reviews*



# 2 Megabytes

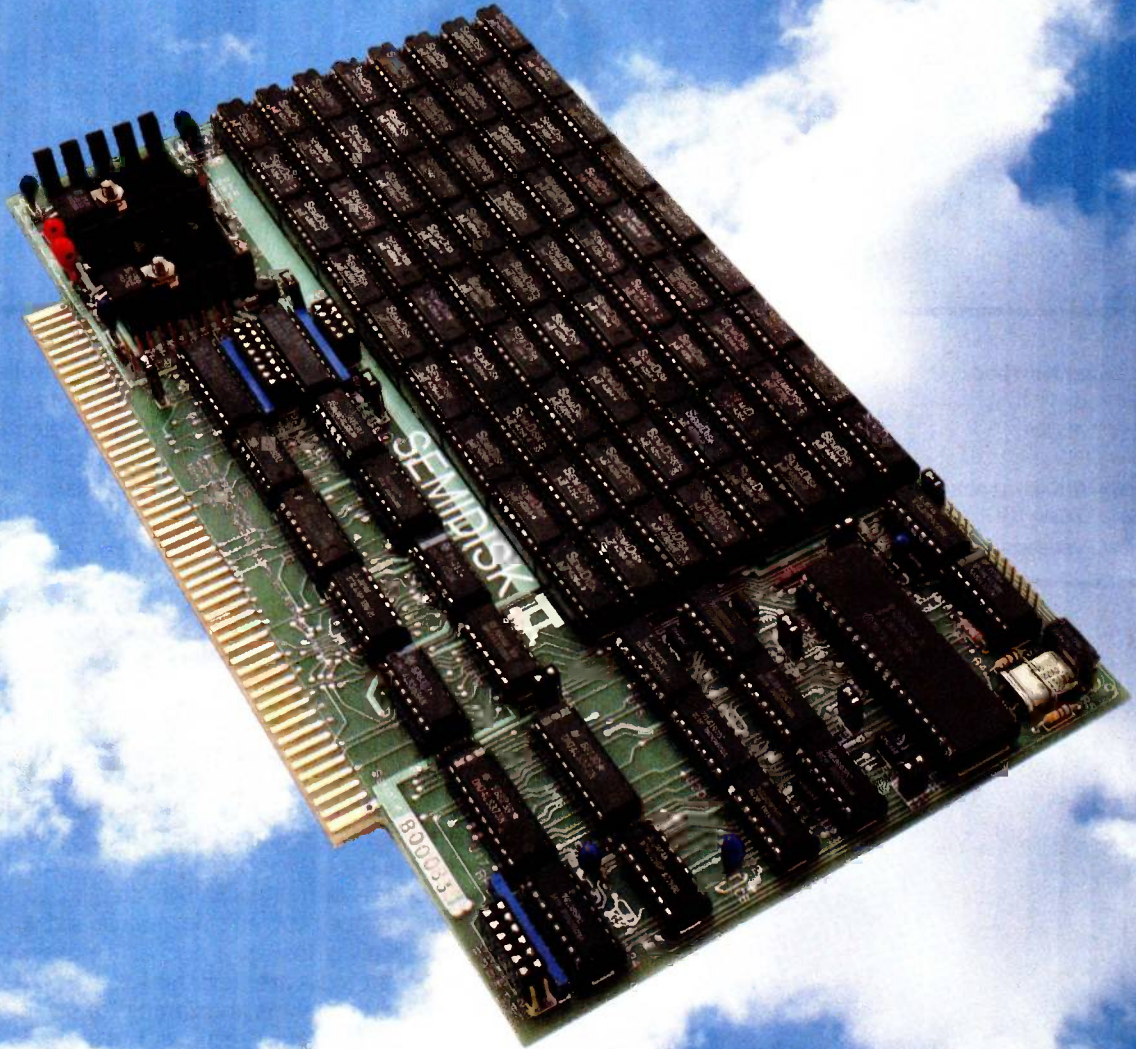

## THE LARGEST CAPACITY DISK EMULATOR YOU HAVE EVER SEEN.

You know about disk emulators. They're fast semiconductor disk drives. Very fast. But until now, the most disk storage you could get on a single board was 1Mbyte. (That was from us, too.) Now we have news that'll really blow your socks off... 2 Megabytes on a single board. Available NOW. That's not a pie-in-the-sky promise.

That's enough storage for dozens of large programs and hundreds of kilobytes of data files. Enough for almost anything you want to do with a disk drive. But that's not all. With SemiSpool, our CP/M print spooler, you can implement a print buffer hundreds of kilobytes long in seconds. All in software. At no extra cost.

Another thing about disk emulators. Unless they're from SemiDisk Systems, they're probably afraid of the dark: Lose power or turn the computer off, and your valuable data goes to that big backup disk in the sky. But our Battery Backup Units keep SemiDisk data flying high while your computer is off, and up to 10 hours during a complete blackout.

So remember this: SemiDisk Systems has been building dedicated microcomputer disk emulators longer than anyone. And larger. And faster. And at a much lower cost. And that's not a lot of hot air.

## AT A PRICE YOU NEVER THOUGHT YOU'D SEE

	<u>512K</u>	<u>1Mbyte</u>	<u>2Mbyte</u>
SemiDisk I, S-100	\$995	\$1795	
SemiDisk II, S-100	\$1295	\$2095	\$2549
IBM PC, XT, AT	\$945	\$1795	\$2499
QX-10, QX-16	\$799		\$2499
TRS-80 II, 12, 16	\$995	\$1795	\$2499
Battery Backup Unit	\$150		

## SEMIDISK

SemiDisk Systems, Inc.  
P.O. Box GG, Beaverton, Oregon 97075  
503-642-3100



Call 503-646-5510 for CBBS/NW, 503-775-4838 for CBBS/PCS, and 503-649-8327 for CBBS/Aloha, all SemiDisk-equipped computer bulletin boards (300/1200 baud). SemiDisk, SemiSpool trademarks of SemiDisk Systems. CP/M trademark of Digital Research.



# R·E·V·I·E·W·E·R'S N·O·T·E·B·O·O·K

---

Cygnets Technologies Inc.'s Communication CoSystem is a combination of hardware and software for integrating the telephone with your IBM Personal Computer (PC) or compatible. For example, you can use it to store a 400-listing telephone directory—each number of which you can access by category, alphabetical order, frequency of use, or with a special speed-dialing code. Each desktop unit gives you one or two telephone lines that you can mix between tone dialing or rotary dialing or both. You get three-party conference calling. You can dial with the phone still on the hook; this is actually more useful than it sounds because you can listen with half an ear to a volume-controllable speaker for the other party to pick up before you have to give it your complete attention. You also get the option of connecting a microphone and using the unit for general conference calling.

If you have two or more CoSystems you get attended or unattended electronic mail. You can also exchange screens and send and receive files to disk. An electronic calendar lets you store your appointments, and it beeps when it's time to be somewhere, call someone, or do something.

What it won't do is let you use one telephone line simultaneously for both voice and data. I've heard about exotic systems that provide this kind of line sharing, and I thought CoSystem—priced at about \$1800—was expensive enough to be that exotic.

Still, for an office where individuals do a lot of telephone work along with a lot of noncommunicating work on an IBM PC, the CoSystem offers a lot of useful features. Because of the price tag, I doubt if it will displace a pop-up menu program combined with a regular push-button-phone/modem-within-arm's-reach for most

BYTE readers, but I wouldn't be surprised if I saw one in use at a car-rental agency.

General Computer Company, Cambridge, Massachusetts, showed us its Hyperdrive, an internally mounted 10-megabyte hard disk for the Macintosh. The expansion package also grows the RAM to 512K bytes. What the company does is line up a dealer. You go to the dealer, who takes your Mac, opens it up, installs the hard disk and new RAM, closes it up, gives it back, and charges you \$2795. Simple, except that it voids the Apple warranty. To get around this, General Computer issues you a new warranty for your Mac as well as for whatever the dealer installs (you can get the Hyperdrive without the 512K-byte expansion package for \$2195 if you already have a Fat Mac, but one way or another, you have to have 512K bytes on your machine). General Computer also installs a fan with a temperature-sensor circuit that kicks into high when the temperature rises.

By mounting the hard disk internally and using a direct logic board interface to connect it to the Mac's main circuit, General Computer has left the serial port alone. You still get to use the standard connections for the modem, printer, or Applebus.

Hyperdrive comes also with extensions to the Macintosh system software. You can partition the hard disk into 32 file drawers or "virtual disks" that automatically resize themselves whenever you add or remove data. You can add password protection at the file level, and you can also encrypt your files and applications. The icon-oriented user interface stays the same, except that you get new icons for the new functions.

We're supposed to get one of these megaMacs for evaluation, and I'm

looking forward to seeing how well it performs.

We've been running the Ericsson PC for the past few weeks as a sort of common-property IBM-compatible for those of us who need only occasional access to the 5¼-inch MS-DOS/PC-DOS format. It has a very nice amber-on-brown display, and the little stand for elevating the monitor is one of those features whose merits become increasingly appreciated. It's supposed to have an ergonomically enhanced keyboard, and on the desk it does seem quite comfortable; for laptop typing, however, I found it too light and the cord too short. Hardly major complaints, being subjective as they are. Too, I thought it curious but not horribly distressing that, while compatible with all of the application programs we have put into it, it will boot only its own version of DOS. The MS-DOS we've used for other IBM PC-compatibles simply won't work. It's not that the disk just spins forever in the drive—the screen goes dead, the drive unit goes dead, and you can't restart it with a Ctrl-Alt-Del. However, seeing as how you get Ericsson DOS with the system, this particular curiosity is simply a curiosity and nothing more.

The Ericsson PC looks intriguing from a number of aspects. It does seem generally compatible with most standard software, and it gives the appearance of being well planned in terms of those features the user will have the most contact with, i.e., the keyboard and the screen. It has a nice small footprint for a desktop, and the evaluation unit sent to us came with a rack for housing it on edge on the floor. This is another unit I'm looking forward to reviewing.

—Glenn Hartwig, *Technical Editor, Reviews*





# The ITT XTRA

It's  
compatible  
with—and it  
improves  
upon—the  
IBM PC

BY JOHN D. UNGER

**T**he IBM Personal Computer (PC) is an easy mark for improvement, and almost every compatible today does many things faster or better than the PC. The ITT XTRA is no exception; it combines compatibility with a number of improvements on the IBM PC and some of the clones. There are, however, no important hardware innovations to differentiate it from compatible microcomputers. Rather, some other, more subtle reasons may form the basis for choosing the XTRA.

It appears that ITT is aiming the machine at business users who have an IBM or similar computer at the office and want a compatible machine at home. The communications software bundled with the XTRA suits this purpose.

A color/graphics board also allows the computer to run IBM PC game software. I reviewed an XTRA with 256K bytes of RAM (random-access read/write memory), two double-sided double-density floppy-disk drives, and a monochrome monitor and monochrome display board. This standard configuration has a list price of \$2395.

## HARDWARE

The XTRA (see photo 1) has the conventional three-piece grouping: a main unit that contains the processor and disk drives, the monitor, and a detached keyboard.

The ASCII (American Standard Code for Information Interchange) keyboard differs slightly from the IBM PC/XT keyboard (see photo 2). Both the Caps Lock and Num Lock keys have light-emitting diodes (LEDs). All of the keys repeat after about half a second. The keycodes are identical to those for the IBM PC.

The amber monitor measures 12 inches diagonally and produces crisp, high-quality characters in a font style that is easy to read (see photo 3). The characters, formed from a 7- by 9-pixel matrix in a 9- by 12-pixel cell, are displayed on an 80 by 25 screen. There is no blurring or distortion as the screen scrolls. The monochrome mode includes

the standard attributes—reverse video, blinking, half- and high-intensity, and underlining—in various combinations and permutations. I cannot say much about the graphics capability of the system since I did not have a graphics board to test in the XTRA. However, I did note that the BIOS (basic input/output system) ROM (read-only memory) routines included interrupt-driven functions that appear identical to those used in creating medium- and high-resolution graphics on the IBM PC, and graphics video RAM is located at the same memory addresses as in the IBM PC.

## STORAGE

The XTRA uses half-height double-sided double-density disk drives, each with a storage capacity of 360K bytes. The drives operate quietly. However, the slot for the lower or B: drive sits only 2½ inches above the table top. If the keyboard is less than 6 or 7 inches from the front of the main unit, it is difficult to insert disks into the drive without flexing them somewhat to clear the keyboard.

The user's guide contains complete and easy-to-follow instructions for installing a half-height 10-megabyte hard-disk drive. This is a modification that requires an expansion card with a controller for the hard disk.

## INTERNALS

To lift the cover off the main unit and gain access to the IBM-compatible expansion slots, the disk drives, and the motherboard, you need only remove two screws from the rear panel. The XTRA uses an 8088 microprocessor at 5 MHz, a nominally faster clock rate than the IBM PC's 4.77 MHz. Next to the 8088 is a socket for installing an 8087 arithmetic coprocessor. The motherboard can hold 256K bytes of RAM (the XTRA uses standard 4164 64K-bit RAM chips in its memory); expansion cards can bring additional memory to a total of 640K bytes. Because the XTRA performs a parity check

*John D. Unger (POB 95, Hamilton, VA 22068) is a geophysicist studying earthquakes and the crustal structure of earthquake-prone regions for the U.S. government. He has a BS. and an M.S. from MIT and a Ph.D. from Dartmouth. He enjoys running, skiing, and keeping a family of five organized.*

---

on its RAM, nine 64K-bit chips have to be installed for every additional 64K bytes of memory. When powered up, the system takes about 32 seconds to check the RAM with 256K bytes installed. To disable the check, you can open the case and easily set 1 position on one of two 8-position DIP (dual-inline package) switches. The switches also set the amount of motherboard memory, the type of monitor, the number of floppy-disk drives, a screen time-out feature, and the presence or absence of the 8087 coprocessor.

The XTRA comes with 32K bytes of ROM, most of which holds the BIOS, but the ROM also provides a set of system diagnostics. These routines are mentioned only briefly in the documentation I received, but the optional technical reference manual describes them in more detail. Pressing the Esc, Ctrl, and Alt keys at the same time runs the program. Typing H at the => prompt gives you a menu with options for running diagnostics of the system hardware, memory, disk drives, video display, and keyboard. The menu also provides access to powerful utilities that read and modify disk sectors and memory.

### INTERFACES

The main unit's back panel contains two 25-pin DB-25 connectors. One, labeled "Printer," is a female Centronics-compatible printer port; the other, marked "Comm. Line," is an RS-232C male asynchronous serial port for communications or a serial printer. An ITT-supplied communications program can configure the serial port from 110 to 9600 bps (bits per second). Both ports are "hard-wired" into the motherboard and therefore do not use the expansion slots. The optional Combo expansion board includes a second parallel printer port.

### SOFTWARE

Advertisements I have seen offer the XTRA only with the standard ITT-DOS 2.11 (MS-

DOS 2.11) and Advanced BASIC, ITT's BASIC-language interpreter. As might be expected from a communications company like ITT, the ITT-DOS disk contains an asynchronous communications program that enables you to access on-line telecommunications services as soon as you connect your modem. Or you can access a nearby computer by running a cable directly from the RS-232C communications port on the XTRA. The communications program includes options to choose parameters, to upload or download ASCII files, and to exit to the operating system without disconnecting. It is a simple, straightforward communications program, but it lacks many of the features—like providing a directory of

*(continued)*



Photo 1: An ITT XTRA with two 360K-byte disk drives.



phone numbers—of PC-Talk III.

ITT describes Advanced BASIC as Microsoft MS-BASIC with GW-BASIC extensions. The full-screen editor and command syntax will be familiar to users of either BASICA or GW-BASIC. The graphics and music commands are identical to those of BASICA; in fact, the two chapters in the ITT BASIC manual describing these features are taken directly from Lyle J. Graham's *Your IBM PC* (Berkeley, CA: Osborne/

McGraw-Hill, 1983). Improvements in the BASIC benchmarks over those for the IBM PC must be owing to enhancements in the BASIC interpreter because the processor clock speeds are nearly identical. The user's guide suggests that the disk with the BASIC interpreter includes a number of sample BASIC programs, but the disk I received with my system did not contain these files.

I used WordStar and Multiplan writ-

ten for the IBM PC to run the benchmark tests for the XTRA; both packages ran perfectly.

## DOCUMENTATION

The user's guide provides simple, easy-to-follow instructions for setting up peripherals and the computer hardware; it also describes the MS-DOS functions that run the system software. The BASIC manual is well organized, with separate sections on file I/O (input/output) and the more complex graphics and sound commands. The third manual explains the MS-DOS commands and the more elaborate programs like EDLIN and DEBUG. The manual is quite complete and includes the DOS functions available through BIOS ROM interrupts, of considerable interest to programmers writing software for the XTRA.

## COMPATIBILITY

I tested a few crucial pieces of IBM software, including WordStar, Multiplan, and the DeSmet C Compiler; all of them ran without problems. Perhaps more important, I examined the BIOS ROM interrupt structure and memory model. There is little to prevent almost complete compatibility with the IBM PC. The biggest difference between the XTRA and the IBM is that the IBM has part of its BASIC interpreter in ROM. Software that uses this feature directly will not run on the XTRA.

There is excellent compatibility between IBM BASIC and ITT's Advanced BASIC. Virtually all programs written in BASIC for the IBM should run on the XTRA with little modification.

The five IBM-compatible expansion slots on the XTRA enable you to add many optional features and functions. Of course, the only sure compatibility test for software and hardware is to try it on the XTRA.

## SALES AND SUPPORT

The first XTRA advertisements I saw proclaimed a nationwide sales and service network through the ComputerLand franchise. I visited a near-

(continued)



Photo 2: The ITT XTRA keyboard has LEDs on the Caps Lock and Num Lock keys and a layout that resembles the IBM Selectric.

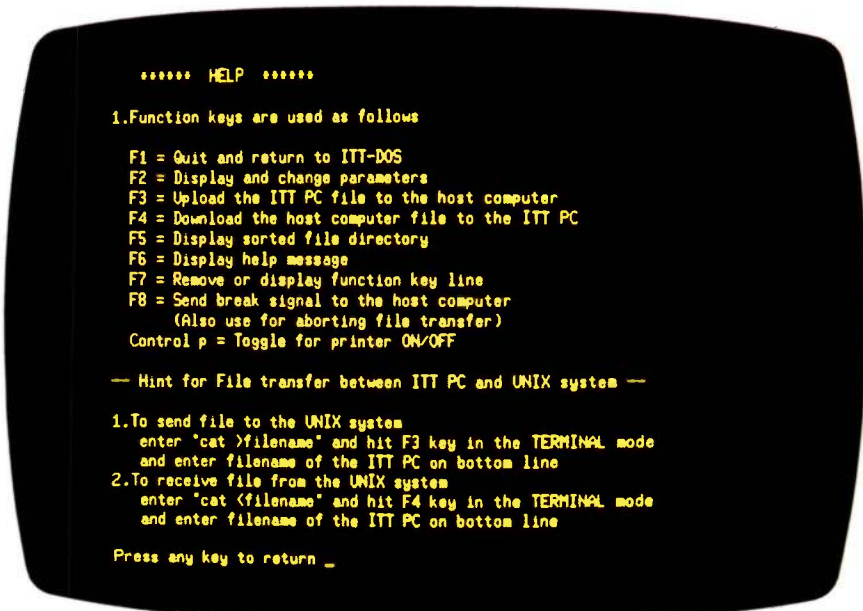

Photo 3: A sample screen display on the ITT XTRA's amber monitor.

## AT A GLANCE

### Name

ITT XTRA

### Manufacturer

ITT Information Systems  
POB 52016  
Phoenix, AZ 85072  
(800) 321-9872

### Components

**Processor:** 8088 at 5 MHz; socket for 8087 coprocessor  
**Memory:** 128K dynamic RAM (standard) expandable in 128K increments to 640K; 32K ROM (BIOS, bootstrap, and self-test) expandable to 64K; 4K text video RAM on monochrome board, 16K graphics video RAM on color/graphics board  
**Display:** monochrome is 80 columns by 25 lines  
**Monitor:** monochrome, 12-inch diagonal, 640- by 400-pixel resolution  
**Keyboard:** detached QWERTY with 84 keys including 10 function keys, numeric keypad, and cursor keys

### Software

MS-DOS 2.11, Advanced BASIC, asynchronous communications

### Expansion Capability

Five card slots (IBM PC bus)

### Documentation

User's guide, 218 pages; Advanced BASIC manual, 505 pages; ITT-DOS manual, 410 pages

### Prices

Model I  
(128K, single 360K drive, monochrome) \$1895  
Model II  
(256K, two drives, monochrome) \$2395  
Model III  
(256K, single drive, 10-megabyte hard disk, monochrome) \$4395  
Monochrome units include monochrome monitor and monochrome expansion board

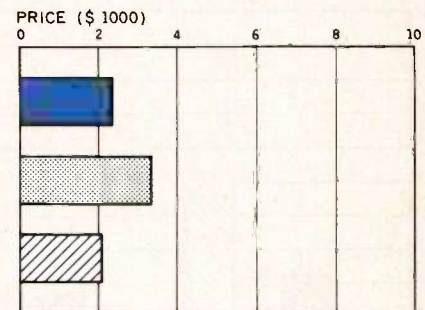
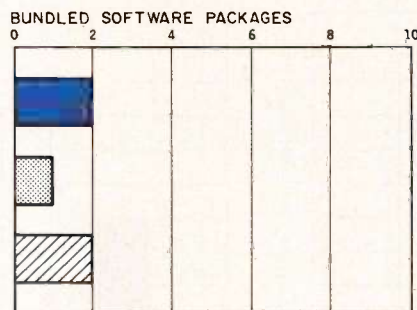
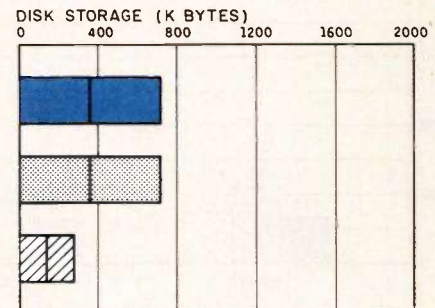
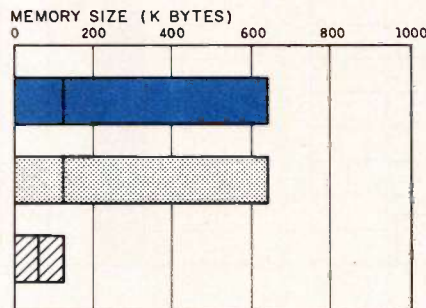

■ ITT XTRA    ■ IBM PC    ■ APPLE II E

The Memory Size graph shows the standard and optional memory available for the three computers under comparison. The Disk Storage graph shows the highest capacity of a single floppy-disk drive for each system. The Bundled Software Packages graph shows the number of software packages included with each system. The Price graph shows the list

price of a system with two high-capacity floppy-disk drives, a monochrome monitor, a printer port and a serial port, 256K bytes of memory (64K bytes for 8-bit systems), and the standard operating system and BASIC interpreter for each system. Note that the price of the ITT XTRA does not include the cost of the color/graphics board.



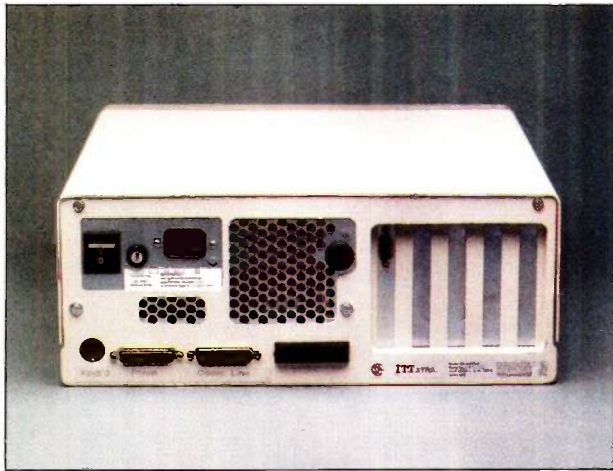

The rear panel has a Centronics-compatible printer port, an RS-232C port, and five IBM-compatible expansion slots.

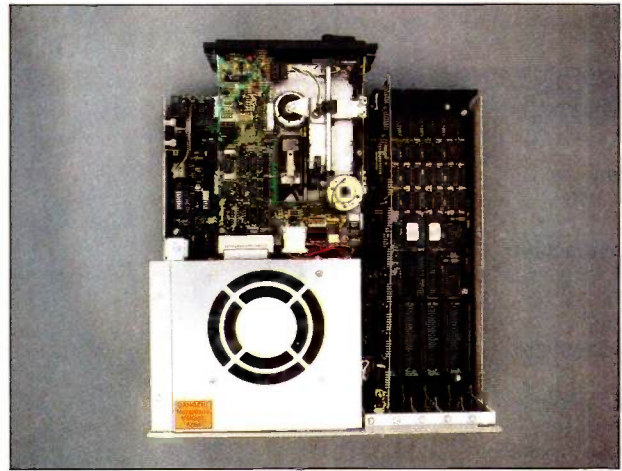

Inside the XTRA. The disk drive extends toward the front of the unit. The five expansion slots and fan are evident.

DISK ACCESS IN BASIC (SEC)

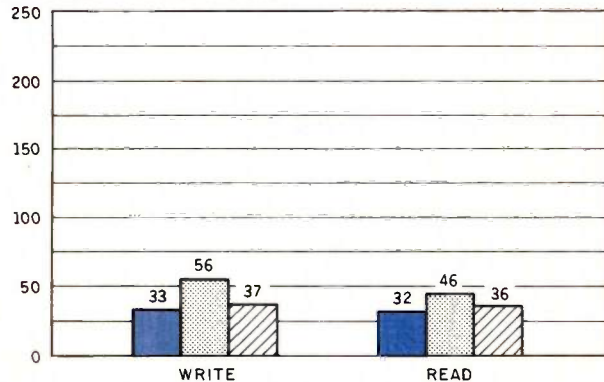

BASIC PERFORMANCE (SEC)

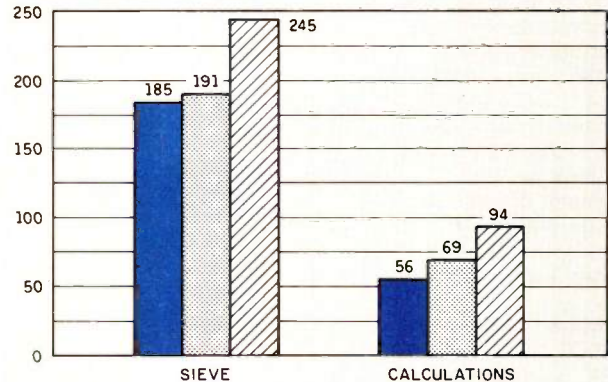

SYSTEM UTILITIES (SEC)

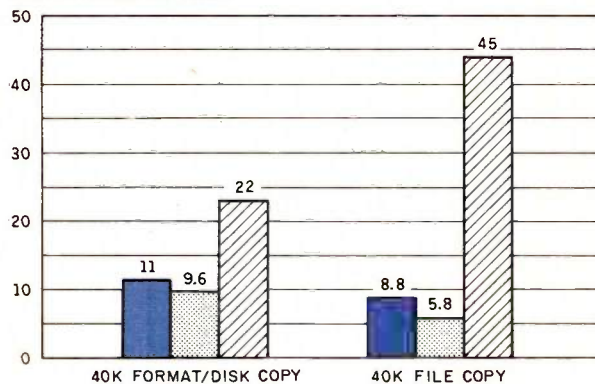

SPREADSHEET (SEC)

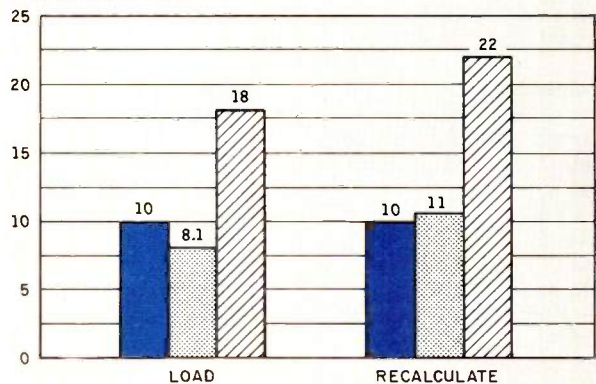

■ ITT XTRA    ■ IBM PC    ▨ APPLE IIe

The graph for Disk Access in BASIC shows how long it takes to write and to read a 64K-byte sequential text file to a blank floppy disk. (For the program listings see June 1984 BYTE, page 327, and October, page 33.) In the BASIC Performance graph, the Sieve results show how long it takes to run one iteration of the Sieve of Eratosthenes prime-number benchmark. In the same graph, the Calculations column shows how long it takes to do 10,000 multiplication and division operations using single-precision numbers. The System Utilities

graph shows how long it takes to format and copy a disk (adjusted time for 40K bytes of disk data) and to transfer a 40K-byte file using the system utilities. The Spreadsheet graph shows how long the computers take to load and recalculate a 25- by 25-cell spreadsheet where each cell equals 1.001 times the cell to its left. Microsoft Multiplan was the spreadsheet used. The tests for the XTRA used MS-DOS 2.11 and ITT Advanced BASIC. Tests for the Apple IIe were done with ProDOS. The IBM PC was tested with PC-DOS 2.0.

by outlet to get some background pricing and technical information and to see what kind of support an owner of an XTRA might receive. I didn't mention that I was writing a review of the XTRA. A prominently displayed XTRA with a large "40% OFF" sign immediately caught my eye. A salesman told me that I was indeed a lucky fellow if I wanted an XTRA because the store had two hard-disk models in stock at a sale price of \$2995, marked down from the list price of \$4995. When I asked about the sale, he told me that the computer had not "moved" very well, and that they were no longer going to stock it.

I telephoned two other stores. At the first store, someone said they had never sold the XTRA. When I mentioned ITT's claim that ComputerLand franchises are selling the machine, the person said that individual store managers could decide whether to carry a given computer. A salesman at the third store said that they had stocked the XTRA for a few months but discontinued it due to poor sales.

I still needed information on the price and on the availability of hardware and software options, so I called the toll-free phone number that ITT provides. A very helpful woman described the available options but said that she "wasn't allowed" to give out prices. ITT was running a promotional rebate program for the XTRA, and each dealership could set its own price for the microcomputer in order to compete for prizes. She then gave me the phone numbers for the stores I had already contacted; when I explained my experience with these stores, she gave me the phone number of ITT's sales representative for my area, whom I then called. He informed me that he worked for the part of the ITT sales force that deals with large purchases. Nonetheless, he gave me price information and told me that he could sell at list price to individuals if they couldn't otherwise find what they wanted.

#### CONCLUSION

The machine appears to be well made and sturdy; I had absolutely no trou-

ble with it. And if something goes wrong, the built-in diagnostics should help pinpoint problems. The documentation lets even novice computer users set up the hardware and get the system running smoothly. The XTRA should run most of the software available for the PC, and it is easy to add PC-style expansion boards. However,

you should consider ITT's relationship with ComputerLand and where you would go for sales and support. ITT's toll-free telephone number ((800) 321-7661) for technical information compensates somewhat for the problem. ITT's low price, especially considering the discounts I encountered, makes the XTRA an attractive value. ■

# Learn the C Language\*

*Introducing*  
**C**

**C LANGUAGE TRAINING SOFTWARE**  
IBM PC-DOS 2.0 +

INTRODUCING C is a C language interpreter and learning guide that teaches the fundamentals of C programming. You'll learn program structure, syntax, and all about libraries - QUICKLY and EASILY. Join the C revolution with INTRODUCING C - from Computer Innovations. Introductory price \$95.

For further information or to order call 800-922-0169.

 **COMPUTER  
INNOVATIONS, INC.**

980 Shrewsbury Avenue, Tinton Falls, NJ 07724 • (201) 542-5920

## \*As Fast As You Can Learn BASIC



# Alloy takes your PC to the limit.

**QICSTOR-PLUS. The ultimate in PC expansion with five IBM compatible slots, hard disk storage, and streaming tape backup in one neat package.**

Alloy's QICSTOR-PLUS meets all your expansion needs. It's the ideal upgrade for a growing PC or AT system.

QICSTOR-PLUS has five full size expansion slots which are completely compatible with the IBM PC bus and they also support Alloy's PC-SLAVE/16 multi-processor, multi-user capability. Its high performance hard disk has a capac-

ity of 36 to 128 MBytes. And QICSTOR-PLUS has file-oriented streaming tape backup with a formatted capacity of over 50 MBytes. Alloy provides file-oriented QTIP software with a transfer rate of 2 MBytes/minute.

QICSTOR-PLUS is available right now. So call Alloy today at (617) 875-6100.



**ALLOY** QICSTOR-PLUS

COMDEX/Spring '85

**ALLOY**  
Computer Products, Inc.

Alloy Computer Products Inc., 100 Pennsylvania Avenue, Framingham, Massachusetts 01701. Tel: (617) 875-6100, TWX: 710-346-0394  
In Europe: Alloy Computer Products (Europe), Ltd., Cirencester, Gloucestershire, England. Tel: 0285-68709, Tlx: 43340



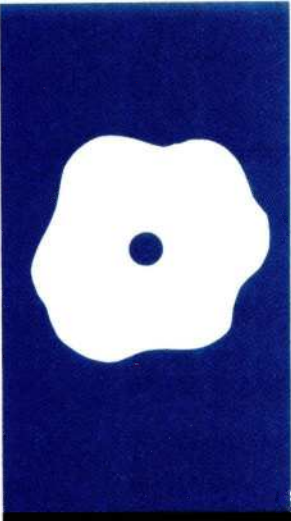

## Insight— A Knowledge System

An expert  
system with  
limited  
potential

BY  
BRUCE D'AMBROSIO

**I**nsight, an artificial-intelligence (AI) system developed by Level 5 Research for IBM PCs and compatibles, lets users develop expert systems at reasonable cost. Insight is a user-friendly, rule-based, knowledge system, combining If...Then rules with goal outlining and probabilistic reasoning. It needs 128K bytes of RAM (random-access read/write memory) and one disk drive, and it sells for \$95. Upon close examination Insight is limited and lacks many facilities required for developing practical knowledge-based programs. It might be best suited for educational purposes.

Insight is a member of a growing class of programming systems that are rule-based. These programming systems include an "inference engine" capable of flexibly interconnecting facts the programmer (knowledge engineer) provides specific to the problem. This frees you from concern about the flow of control in the program and lets you concentrate on the knowledge necessary to solve the problem. Key aspects of such systems are the facilities for structuring data, the flexibility of the rule language, the efficiency of the inference engine, and the program-development environment (availability of an editor, debugger, etc.).

### DATA STRUCTURING

AI systems are designed for complex problems that are not amenable to normal programming techniques, and they have generally provided highly sophisticated facilities for structuring data. Although Insight has two basic data types, Boolean and numeric, neither character data nor the simplest structuring of variables into records or frames is available. Also, variables reside in a single global context, analogous to early compilers in which no local variables existed within subroutines.

Variable names in Insight can have embedded spaces; this permits writing rules that look very advanced but have an underlying simplicity. For example, in Insight you can write

```
IF the animal has hair  
THEN the animal is a mammal
```

This looks less impressive if you know that the animal has hair is simply a variable name and could just as easily have been written the-animal-has-hair.

This lack of data-structuring capability is not important for simple problems in which you never need to consider more than one of any kind of data. Imagine, however, a problem in which you need to consider several pieces of data of the same type. For example, you might need to gather information about all of an individual's bank accounts to advise him on banking services. Or you might have a diagnostic program that needs to gather information about several occurrences of failure before reaching a diagnosis. Rule-based systems do exist that offer the ability to structure basic data into more complex units that can be referred to independently. (EMYCIN, the first general-purpose mainframe system designed for expert-system development, has such a facility called "contexts.")

For example, you might gather all the facts about a bank account into a context called "bank account." You would then be able to write a rule in the form

```
IF there is a bank account with  
deposits > $10,000  
AND that same bank account has  
stable months > 6  
THEN .....
```

You could achieve the same effect in Insight only by laboriously reproducing each rule and data item and adding an extra variable to record the number of accounts:

```
IF number of accounts ≥ 1  
AND bank account 1 deposit amount  
> $10,000  
AND bank account 1 stable months > 6  
THEN .....
```

(continued)

Bruce D'Ambrosio (555 Tulsa St., San Lorenzo, CA 94580) is studying for his Ph.D. in computer science at the University of California at Berkeley.



## AT A GLANCE

**Name**

Insight

**Type**

Knowledge system

**Manufacturer**

Level 5 Research  
4980 South A-1-A  
Melbourne Beach, FL 32951  
(305) 676-5810

**Format**

5¼-inch floppy disk

**Computer**

IBM PC or compatible, DEC Rainbow,  
Victor 9000

**Features**

Rule compiler, inference engine, and  
sample knowledge bases

**Documentation**

44-page users guide

**Price**

\$95

**Audience**

Those interested in AI technology and  
expert systems

**Comments**

A simple system of limited utility—best as  
an educational tool

IF number of accounts  $\geq$  2  
AND bank account 2 deposit  
amount  $>$  \$10,000  
AND bank account 2 stable  
months  $>$  6  
THEN . . .

You have to hope that no one has more accounts than you allowed for. While you could use this technique for simple situations, you're in trouble if you need to nest such constructs (for example, if you wish to record a series of deposits for each bank account).

**RULE LANGUAGE**

Like the data-structuring facility, Insight's rule language is the minimum for a rule-based system. Unlike the data facility, however, there is no way around the limitations. The only operations available in Insight's rule language are testing a Boolean variable's truth value, comparison of a numeric variable's value to a constant, and display of recorded text. Insight provides no facilities for assigning values to numeric variables (other than by asking the user), performing even the most limited forms of arithmetic computation, or modifying text in any way before display (for example, by inserting the user name or the name of the current context).

Perhaps the language's most limiting feature is that it does not provide any underlying general-purpose language into which the knowledge engineer can escape. It has been estimated that as much as 30 to 50 percent of the knowledge in a typical EMYCIN system is not in rules but is coded directly in LISP. Personal Consultant, a Texas Instruments knowledge-engineering tool for its TI PC, provides this facility with an escape into IQLISP, the underlying language. And M.I., a knowledge system from Teknowledge (Palo Alto, California) for the IBM PC, has extended the rule language into a complete symbolic-programming system, so that any arbitrary knowledge can be incorporated. Insight has provided neither of these alternatives, and this seems to be a serious limitation.

As an example, consider the following rule:

IF liquid assets + equity  $>$   
\$100,000  
THEN client is wealthy

Insight has no way to express this rule, except for the trivial interpretation that liquid assets + equity is a single variable.

**INFERENCE ENGINE**

The inference engine in Insight, like that in many rule-based systems, is a simple backward-chaining engine. Insight also has a structured goal mechanism that provides some explicit measure of control over the running knowledge program. This facility lets you specify which problem areas in a particular Insight knowledge base interest you. And it allows construction of large multifaceted knowledge bases. I found this of limited utility.

Other facilities provided by the inference component of some knowledge systems include "why" questions that display the currently active rule, display of text that further describes the information requested, and justifications of conclusions reached. Although Insight always displays the most immediate conclusion being sought, it does not provide any facility to display the entire rule or any way to display the chain of reasoning that led it to consider that rule.

One nice feature is the ability to attach text explanations to variables. When a value is requested for a variable, say "liquid assets," you can press function key 4 to get an explanation of the term "liquid assets."

And finally, Insight has an optional report that you can produce at the end of a consultation and direct to the console or the printer; the report serves some of the purposes of justification. However, this report appears to be a randomly ordered listing of all rules considered and the conclusion reached. For one simple problem I presented (using the 15 rules for determining an animal species), Insight produced a five-page justification listing. A justification should be

## REVIEW: INSIGHT

a more reasoned argument, limited to those rules that directly apply to the conclusions. This report feature might be useful for debugging, but it is not of much use as an end-user facility.

## ENVIRONMENT

The user interacts with Insight through a menu- and function-key-based interface. This interface is simple, easy to use, and seems well thought out. When the system can determine a list of options for a variable, it presents them, and you can scroll through the list with the cursor until you select the desired option (shown by highlighting).

You can use the function keys to select options such as restart (start the consultation over from the beginning), expand (display text explanation of this variable if one is available), and help (display Insight's internal-help text describing what is happening, format for correct entry, and so on). The combination of user-defined expand displays, clear internal-help text, and menu-based display and input do make an Insight knowledge system easy to use.

## IN GENERAL

Insight is a compiler-based system, so rules, once written, must be processed by a rule compiler before the Insight inference engine can use them. Most of the compiler/interpreter arguments apply to rule-based languages as well as procedural languages, so you would expect Insight to be fast, capable of handling large programs, but not as convenient for program development. In fact, all these expectations are correct. (Insight is memory-dependent, but on my system the compiler can compile rule bases of over 4000 rules. M.I can hold only about 200 rules, and TI PC about 400.)

Insight has shortcomings if you use it for program development. You cannot obtain displays of the currently active rule chains. Since it is the inference engine, not the knowledge engineer, that links rules together, such a display would be very helpful in understanding the relationships

between rules when building a knowledge base and would help the user understand why a rule-based program is asking a particular question. Also, as is usual with compiler-based systems, you cannot interrupt a running program and inquire about the values of program variables (actually, symbolic debuggers for compiled procedural languages do offer this capability, but Insight has nothing comparable).

Insight provides no special aids for program development. The knowledge engineer must supply his own editor for constructing rule bases. Once a rule base is built as a text file, the PRGEN compiler converts the rule base into executable form. The compiler has no options, and errors detected during compiling are displayed on the console. The error display includes the text-file line number and a short error message. Although these error messages don't always point directly to the problem in the source file, it is not too difficult to figure out what to change.

Finally, the Insight users manual (44 pages plus appendixes) is adequate for using the system but leaves many areas vague. I would like more information on such details as the algorithms used for confidence value combination or the internal structure of the inference engine. *[Editor's note: A confidence value is a method of answering an Insight question that is a numeric value between an absolute yes (a confidence value of 1) and an absolute no (with a value of 0). For example, if you were developing an expert system for choosing a wine, you could tell an expert system that you liked white wine with a confidence value of 0.8.]* Such information can be important when you are attempting to engineer a complex knowledge base.

For building rule-based systems, Insight is a product that offers a friendly user interface and a rule compiler for fast execution of large rule bases. For \$95, it offers an inexpensive way to explore the possibilities of rule-based systems. Its data-structuring facilities and rule language are so limited, however, that it is only suitable for a small class of problems. ■

## Save big on the world's largest selection of computer printers

**With 189 brands and 630 models, we make printers our only business!**

- Printerland doesn't raise prices—only lowers them.
- By the time you read this, prices here have probably been lowered again!
- Unlike a mail order house, we provide service and helpful solutions. Call us with questions!

**PRINTERLAND WILL PAY THE SHIPPING**

ABATI LQ-20 List Price \$479	Our Price	<b>\$391<sup>90</sup></b>
AMDEK 5055 List Price \$1995	Our Price	<b>\$1423<sup>10</sup></b>
ANADEX DP 6500 List Price \$2995	Our Price	<b>\$2487<sup>15</sup></b>
CITIZEN MSP10 List Price \$499	Our Price	<b>\$377<sup>70</sup></b>
C.ITOH 3500 List Price \$1995	Our Price	<b>\$1837<sup>15</sup></b>
CORONA LASER List Price \$3395	Our Price	<b>\$2995<sup>90</sup></b>
DATASOUTH DS220 List Price \$1695	Our Price	<b>\$1587<sup>95</sup></b>
FUJITSU SP830 List Price \$2950	Our Price	<b>\$2687<sup>75</sup></b>
GBT 6600 LASER List Price \$22500	Our Price	<b>\$19995<sup>00</sup></b>
GENERAL OPTICS H28 LASER List Price \$12500	Our Price	<b>\$11650<sup>00</sup></b>
KONICA LP3010 LASER List Price \$3995	Our Price	<b>\$3787<sup>10</sup></b>
OKIDATA 2410 List Price \$2395	Our Price	<b>\$1972<sup>10</sup></b>
QUANTEX 7065 List Price \$1995	Our Price	<b>\$1784<sup>25</sup></b>
QUME II/90 List Price \$2695	Our Price	<b>\$2493<sup>85</sup></b>
SILVER REED 400 List Price \$399	Our Price	<b>\$285<sup>95</sup></b>
TEXAS INSTRUMENTS 865 List Price \$1299	Our Price	<b>\$1111<sup>10</sup></b>
TOSHIBA 1350 List Price \$1895	Our Price	<b>\$1089<sup>00</sup></b>

**If for any reason you are dissatisfied with your new printer from Printerland, you may return it within one week for a full refund.**

Printerland welcomes payments in cash or certified checks—no personal checks please. MasterCard and Visa purchases accepted with slight additional fee. Add 7% sales tax for orders in Illinois. Printerland will guarantee your shipment the day your order is received.

Prices subject to change without notice

**TO ORDER NOW CALL TOLL FREE**

**1-800-255-9888**

In Illinois call (312) 255-9888

5834 Dempster St., Morton Grove, IL 60053  
1740 Algonquin Rd., Arlington Heights, IL 60005

**PRINTERLAND**  
inc.



## MORE ON MULTIMATE

CJ Puotinen did not stress enough MultiMate's problems with repagination and virtual paging in "Leading Edge and MultiMate" (November 1984, page 287). The product is a nightmare for anyone who writes more than one-page documents. MultiMate was geared toward a secretarial staff, but it's being recommended by salespeople as a Wang clone. There is no comparison; Wang's dedicated word processor works without a hitch, and professional writers can use it comfortably for composition.

MultiMate is so unreliable that you shouldn't trust it for important documents. It is also unbearably slow for final editing when you are switching between pages.

MultiMate works so poorly that I'm reluctant to spend money on a replacement in case that doesn't work either. Suffice it to say, I've learned to take the time to make backup copies so I can recover the parts of text I lose when repagination doesn't work. And Ms. Puotinen doesn't even mention how inconvenient it is to make a backup copy or the time it takes to proofread documents for MultiMate's errors. Before switching to a Tandy 2000 and MultiMate, I used Microsoft Word and an IBM PC; I have regretted my switch since I made it.

MAUREEN FLEMING  
*Stamford, CT*

## SPIRIT 80

I consider BYTE to be among the best computer magazines published today. However, one problem undermines your good editorial and journalistic intentions: your reviews, and those of other magazines, are simply not to be trusted.

I have a Mannesmann Tally Spirit 80 printer, and I have just finished reading Mark Welch's review (November 1984, page 335). Mr. Welch makes much of paper jamming but fails to point out two vital characteristics of the machine that prospective buyers need to know about.

First, the Spirit offers only elite type. Also, only its right tractor slides; the left one is fixed. Should you wish to run labels, you cannot run them in the center, but

only at the left margin. For a word processor that normally starts text in column nine, the left margin default must be adjusted to zero.

SHEL KAGAN  
*Bristol, RI*

## THE TANDY 2000

I read with pleasure the articles in BYTE concerning Tandy's computer products—particularly the review "The Tandy Model 2000" by Mark S. Jennings (December 1984, page 239). As an alternative to the IBM PC or PC XT, the Tandy 2000 is a truly exceptional machine. I would like to make some comments about Mr. Jennings's fine review.

Mr. Jennings does not adequately explain the speed advantage of the 80186 microprocessor. Simply stating that it has a higher clock rate is not enough—the 80186 was completely re-engineered and the microcode was overhauled. An 80186 running at 4.77 MHz (standard IBM speed) is almost twice as fast as the 8088. By almost doubling the clock rate from 4.77 to 8.0 MHz, the Tandy 2000 can operate as much as four times faster than the IBM PC; some operations are even faster. In addition, the 2000 is not hampered by transferring data from the processor to memory over an 8-bit data bus—it has a true 16-bit data bus.

I must take exception to the claim that the Model 2000 does not achieve overall increased performance. I agree that the greatest improvement is achieved when running a processor-intensive application; however, the corollary is not necessarily true. Disk-based applications run faster for two reasons: ability to use the 16-bit data path and a much faster disk drive than the Teac drives used in the IBM PC. Mr. Jennings states that there is no significant difference in disk I/O (input/output) speed, yet the published benchmark times indicate approximately a 50 percent improvement.

Mr. Jennings was not nearly critical enough concerning Tandy's manipulations of the basic input/output system (BIOS) for this machine. Fortunately, since his article was written, Tandy has released MS-DOS version 02.11.xx, which fixes many of

these problems. Software that depends on the features normally available on the IBM PC now works correctly.

Several times, Mr. Jennings alludes to having to perform a two-step operation for formatting and copying a disk; Disk Copy on the IBM PC does both. He must have missed the COMPDUPE utility, which not only does both but also performs a verify and a disk byte-for-byte comparison.

Mr. Jennings correctly identifies an area that has pained us all: Color update on the monitor was terribly slow. The BIOS "error" that caused this has been corrected with the new release of MS-DOS. Also, Mr. Jennings is not entirely correct in saying that you cannot generate text in the color-graphics mode. If you are mixing text and graphics, this is true. If you want only color text, you can program the monochrome attribute ports (beginning with 0198 hexadecimal) to provide full-color attributes for your application at black-and-white speed. You can use this technique within BASIC by setting the screen into the black-and-white text mode with a SCREEN 0,0,0 statement and using Out to set the port values.

I find that the Format command does not have extra options; in fact, several options available on the IBM PC are missing. Specifically, the options for formatting a single-sided disk, formatting with eight sectors, and allocating system file space are not available. While the first two options are not really meaningful with the 96-tpi (tracks per inch) drives, the latter option is a loss. You cannot build a distribution disk with the space allocated for system files.

On the issue of software compatibility, I find that many generic MS-DOS programs will run with no changes. Unfortunately, most IBM PC programs go directly to the hardware or ROM (read-only memory) firmware to bypass the system's slow speed. This is particularly true in most BASIC applications and I find these most incompatible with the MS-DOS machines.

Mr. Jennings alludes to the generic nature of the software available through Tandy's Express Order Software. This is incorrect: Each package available through

(continued)

# Here's The Savvy-est True Dual Trace 10 MHz Digital Storage Scope You Ever Saw . . . At The Saving-est Price. Only \$595.

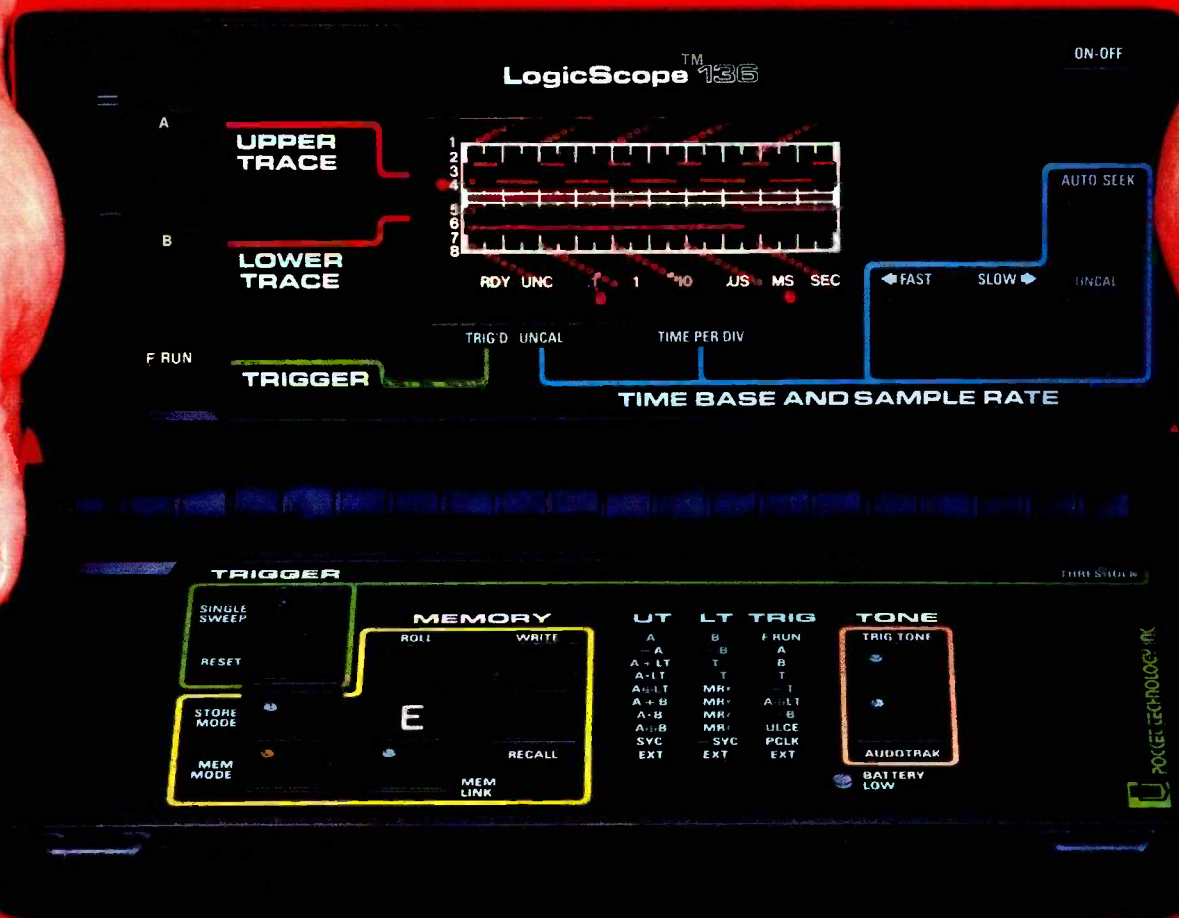

## The Handy New LogicScope™ 136

True Dual Trace • 10 MHz Real Time Bandwidth • 3 Input Channels • I/O Port  
 Digital Waveform Storage • Boolean Waveform Operations • Audio Functions  
 8.0 (L) x 4.5 (D) x 1.75 (H) Inches • 1.25 Pounds • 9 Volt Battery/AC Operation

### Consider the LogicScope 136

- The LogicScope 136 is the next logical step in test instrumentation for you. It combines many of the features and capabilities of sophisticated logic analyzers and oscilloscopes . . . and it fits in your hand. Never before has so much technology been available in so small an instrument, at such a low price.
- The pocket-sized LogicScope 136 is made possible by a patented breakthrough in display technology. The conventional CRT has been replaced by a unique array of 400 LED's that permits simultaneous display of two digital waveforms.
- The 136 can be used for viewing single shot events, or repetitive waveforms. It can be operated in real time mode, or in memory mode which permits acquisition and storage of up to 50-100 bit waveforms. These can be recalled, logically compared (AND, OR, EXCLUSIVE OR) to other input waveforms, or output to an external device via an I/O port. This I/O port will also accept future add-on 136 Modules.
- Its very low cost, convenience and ease-of-use make the LogicScope the ideal instrument, for designing, troubleshooting or repairing digital systems. Made in U.S.A.

### Consider its Engineering & Field Service Applications:

- On microprocessor-based systems, check the timing relationship of various parameters relative to the system clock and other key events. Its storage capability allows visual and logical comparison of non-repetitive waveforms to known reference signals. Output in the start-up of the digital device can be compared to reference signals to determine the operating state of the device. Questionable waveforms can be stored for analysis.
- Its light weight and small size make the LogicScope convenient to take on every service call. The 136 provides much more information for trouble shooting a digital system or peripheral than a logic probe or digital counter without having to lug an oscilloscope or logic analyzer along.

### Contact us for the name of your local distributor



**POCKET TECHNOLOGY, INC.**

7320 Parkway Drive, Hanover, MD 21076 U.S.A.

301-796-3300 TELEX 908207

Division of Renaissance Technology Corp.



this service is completely compatible with the 2000 and generally will not work with any other IBM-type machine. Most have been fine-tuned to make use of the 2000's superior capabilities and are hardware-specific.

Mr. Jennings comments that the 2000 must be able to read IBM disks to run the software. The 2000 can read any IBM-format disk, either single- or double-sided and either eight or nine sectors per track. Many of the software packages I have received are generic IBM PC/Model 2000 and come on single-sided disks compatible with PC-DOS 1.X or 2.X. Because of the narrow disk head required for 96 tpi, the 2000 cannot write understandable data to an IBM PC disk unless it has just been formatted.

JOHN B. HARRELL III  
Washington, DC

*In regard to the 2000's processor, my article mentions that the 80186 has a 16-bit data bus and that it has a number of functions on the chip rather than in separate chips as does the IBM PC's 8088. I don't know about any overhauls of microcode. In any case, I have run a large number of programs on both machines and have yet to see any program perform more than three times faster on the 2000.*

*The lead to the article clearly states that the 2000 has better overall performance than the IBM PC. I correctly state that increases in performance depend on the program. Programs that are processor-intensive will show the most improvement.*

*You overstate any disk-access speed advantage that the 2000 might have over the IBM PC. The Disk Access in BASIC benchmark is a poor benchmark to com-*

*pare pure disk-access speed because a significant amount of time is spent by BASIC interpreting the code. Please note that the 2000 is actually 41 percent slower than the IBM PC in the 40K File Copy benchmark; this benchmark is a better measure of how quickly the computer can simply read and write to disk. It might be true that the 2000 is faster in seeking random data on disk; I don't know because I haven't seen any benchmarks. In any case, the average 2000 user is unlikely to notice improved disk performance over an IBM PC; my overall impression is that maybe it is a tad slower.*

*By the way, to my knowledge no IBM PC has come from the factory with Teac drives, although they are commonly fitted in the aftermarket. Tandon seems to be the most common IBM PC drive.*

*You are entirely correct about the COMPUPE command. I knew about this command, but the benchmarks had been previously run by a BYTE staffer who did not know about it. This is the reason for the reference to separate commands at the bottom of the benchmark comparisons.*

*I think it is still correct to state that the 2000 cannot generate high-speed text in the color-graphics mode. The key point is that if you have a program that mixes color graphics and text on the same screen, you should be prepared for very slow text display.*

*It would have been more accurate if I had said that the Format command has different options rather than extra options. It does have one extra option (for setting skew and interleave factors) and it is missing several others. I agree that Tandy should have included the options for different disk formats.*

*When I stated that most of the pro-*

*grams available from the Express Order System were generic MS-DOS, I meant that most of them were fairly standard MS-DOS programs that the vendor could easily port over to the 2000. I did not mean to imply that they were somehow incompatible with the 2000. As to the comment that Express Order software will not work on an IBM-type machine, I think that this is usually due to copy-protection schemes and the fact that the 80-track 2000 disks can't be read by a standard IBM PC. None of the Express Order System programs that I have seen running seem to have any special fine-tuning.*

*Your clarification of the 2000's capabilities to read and write IBM PC disks matches my understanding. However, I think that the article is fairly clear already in this regard.*

—MARK S. JENNINGS  
Durham, NC

## MACFORTH AND THE SIEVE

I wish to submit a correction to "The First Look at FORTH on the Mac" by Gregg Williams (December 1984, page A115). In table 1 you list the time for the Sieve of Eratosthenes in MacFORTH at 36.2 seconds. The FORTH text in listing 1 at left is from block 7 of FORTH blocks included with MacFORTH 1.1. If you load it, you'll find that it runs 10 iterations of the Sieve in 20 seconds.

I assume the times listed in table 1 are for one iteration with an array size of 8199.

DAVID R. McDONALD  
Pittsburgh, PA

*The Sieve program you sent does in fact run in 20 seconds. But you miss the point of a benchmark: to run the same code (as closely as possible) under different circumstances. If you had typed in the benchmark referenced in my article, your results would be close to mine. I retimed the benchmark and got times of 36.4 and 37.0. I hope this explains the difference you found.*

—GREGG WILLIAMS  
Senior Technical Editor

Listing 1: Alternative Sieve benchmark for MacFORTH.

```
8192 constant size      create flags size allot

:primes  flags size 0 1 fill ( empty array )
0 ( prime counter ) size 0 ( range )
do flags i+ c@
  if 3 i+ i+ dup i+ size < ( avoid known nonprimes)
    do 0 ic! dup      ( flick mod prime flags)
    + loop
  then drop 1+ ( another prime )
  then
loop
." primes ";

: 10times 1 sysbeep 10 0 do primes loop 1 sysbeep;
```

REVIEW FEEDBACK is a column of readers' letters. We welcome responses that support or challenge BYTE reviews. Send letters to Review Feedback, BYTE Publications, POB 372, Hancock, NH 03449. Name and address must be on all letters.

Gould... Innovation and Quality in Hard Copy Color Graphics

# You need a plotter that's compatible with your hardware, software and, especially, you.

More and more companies are discovering that color graphics help them communicate faster and more persuasively.

When you make this discovery, you'll want a Colorwriter™ pen plotter from Gould. Because Colorwriters are easy to use, and can meet all of your business and technical graphic needs. They'll work with virtually any computer and the most popular software packages available.

Whether you want simple bar charts or complicated CAD/CAM drawings in 8½" x 11" or 11" x 17" formats,

we've got a plotter to suit your needs and your budget. Plus, we've got a unique automatic chart advance option for volume graphics applications.

When you buy a Gould Colorwriter plotter you're getting 45 years of proven experience in hard copy graphics technology. That's why you also get one of the best warranties in the business.

For more information and the name of the Colorwriter dealer nearest you, call toll free **800-447-4700**, operator 99. Or write Gould Inc., Recording Systems Division, 3631 Perkins Ave., Cleveland, Ohio 44114.



**Gould  
Colorwriter.  
The compatible  
plotters.**

 **GOULD**  
Electronics

Inquiry 172



# This is the only place you'll find Optically- Isolated Analog Modules.



Optically isolated analog input or output modules available from Opto 22.

Five years ago we introduced the industry standard optically isolated digital I/O modules. The optically isolated analog I/O modules are now ready.

Our engineers have combined signal conditioning A/D or D/A conversion and optical isolation in a single module at prices you have been waiting for, and they've designed a module for every application: ■ Thermocouple input modules (Type J & K) ■ Voltage input and output modules ■ Current input and output modules ■ Temperature sensing module with ICTD probe

All modules plug into four position or sixteen position racks with an on-board microcomputer that communicates to your host computer via a simple twisted pair.

Optically isolated analog modules — the new industry standard.



15461 Springdale Street • Huntington Beach • CA • (714) 891-5861 • (800) 854-8851

Inquiry 289 for Dealers. Inquiry 290 for End Users.



# Kernel

RENOVATION AT CHAOS MANOR created a surprise: a trench full of rainwater in front of Jerry Pournelle's front door. But, as Jerry points out, this obstacle didn't seem to slow down the flow of new products.

John Markoff and Phillip Robinson also write about a flood of new products from their Palo Alto perspective in BYTE West Coast.

In BYTE U.K., Dick Pountain describes I.D.E.A.S. (Inference Driven Evolutionary Applications Software), a database generator that employs AI frame theory.

Bill Raike reports on activities at the International Conference on Fifth Generation Computer Systems and other happenings in BYTE Japan.

This month, Steve Ciarcia again answers readers' questions in Circuit Cellar Feedback.

**COMPUTING AT CHAOS MANOR: OVER THE MOAT**  
*by Jerry Pournelle* . . . . . 355

**CHAOS MANOR MAIL**  
*conducted by Jerry Pournelle* . . . . . 373

**BYTE WEST COAST:  
LASERS, OFFICE PUBLISHING, AND MORE**  
*by John Markoff and Phillip Robinson* . . . . . 379

**BYTE U.K.: NEW DATABASE IDEAS**  
*by Dick Pountain* . . . . . 389

**BYTE JAPAN: THE FIFTH GENERATION IN JAPAN**  
*by William M. Raike* . . . . . 401

**CIRCUIT CELLAR FEEDBACK**  
*conducted by Steve Ciarcia* . . . . . 408



# THE PROGRAMMER'S SHOP™

helps compare, evaluate, find products. Straight answers for serious programmers.

## SERVICES

- Programmer's Referral List
- Compare Products
- Help find a Publisher
- Evaluation Literature free
- BULLETIN BOARD - 7 PM to 7 AM 617-826-4086
- Dealer's Inquire
- Newsletter
- Rush Order
- Over 700 products

## Free Literature - Compare Products

Evaluate products Compare competitors Learn about new alternatives. One free call brings information on just about any programming need Ask for any "Packet" or "Addon Packet"  ADA, Modula  AI  BASIC  C  COBOL  Editors  FORTH  FORTRAN  PASCAL  UNIX/PC or  Debuggers, Linkers, etc

## RECENT DISCOVERIES

FASTER C - Lattice users eliminate Link step. Normal 27 seconds, Faster C in 13 secs. MSDOS \$95

## ARTIFICIAL INTELLIGENCE

EXSYS - Expert System building tool. Full RAM, Probability, Why, Intriguing, serious. PC DOS \$275

GC LISP - "COMMON LISP", Help, tutorial, co-routines, compiled functions, thorough. PC DOS \$475

IQ LISP - MACLISP & INTERLISP. Full RAM. Liked. PC DOS \$155

TLC LISP - "LISP-machine"-like, all RAM, classes, turtle graphics 8087. CP/M-86, MSDOS \$235

TLC LOGO - fast, classes. CPM \$ 95

PROLOG-86 - Learn fast, Standard, tutorials, samples of Natural Language, Exp. Sys. MSDOS \$125

Expert System front-ends for PROLOG: APES (\$275), ES/P (\$1895)

Other solid alternatives include: MuLISP-86 (\$189), WALTZ LISP for CPM (\$159), MicroPROLOG (\$275)

## EDITORS FOR PROGRAMMING

BRIEF Programmer's Editor - undo, windows, reconfigurable, macro programs, powerful. PC DOS \$195

VEDIT - well liked, macros, buffers, CPM-80-86, MSDOS, PC DOS \$119

## MACINTOSH

We evaluate, carry every available programmers product. Ask.

## C LANGUAGE

INSTANT C - Interactive development - Edit, Source Debug, run. Edit to Run - 3 Secs. MSDOS \$ 495

"INTRODUCING C" - Interactive C to learn fast. 500 page tutorial, examples, graphics. PC DOS \$ 95

MEGAMAX C - native Macintosh has fast compile, tight code, K&R, toolkit, .OBJ, DisASM MAC \$ 295

CROSS COMPILERS by Lattice, CI. VAX to 8086. VMS \$3000

## C LIBRARIES

COMMUNICATIONS by Greenleaf (\$149) or Software Horizons (\$139) includes Modem7, interrupts, etc. Source. Ask for Greenleaf demo.

C SHARP Realtime Toolkit - well supported, thorough, portable, objects, state sys. Source MANY \$ 600

PORTABLE C-LIB: Same calls for IBM, Ite, CP/M, C64, more. Screen, I/O, Graphic, more. \$ 125

ROMPack - special \$Main .EXE editor, source, tech support, 8086. \$185

## DEBUGGERS

PERISCOPE DEBUGGER - load after "bombs", symbolic, "Reset box", 2 Screen, own 16K. PC DOS \$ 285

SOURCE PROBE by Atron for Lattice, MS C, Pascal. Windows single step, 2 screen, log file. \$395

## FORTRAN LANGUAGE

RM/FORTRAN - Full '77, big arrays. 8087, debugging, xref, MSDOS \$525

DR/Fortran-77 - full ANSI 77, 8087, overlay, full RAM, big arrays, complex NUMS., CPM86, MSDOS \$249

Ask about Microsoft, Supersoft, others.

## OTHER LANGUAGES

ASSEMBLER - ask about Microsoft MASM-86 (\$125) improvements or its new competitors.

"BASICA COMPILER": Better BASIC all RAM, modules, structure. \$185

HS/FORTH - '79 & '83 Standards, full RAM, ASM, BIOS, interrupts, graph, multi-task, optimizer MSDOS \$250

MBP COBOL has screen control, strong doc. '74 interm., fast. MSDOS \$680

## SUPPORT PRODUCTS

BASIC DEVELOPMENT SYSTEM - (BDS) for BASICA; Adds Renum, crossref, compress. PC DOS \$115

PLINK-86 for Overlays, most lang., segment control. MSDOS \$325

ProYAM Communications Package - All a programmer'd want. TTY, VT 100, 3101, MODEM7, BBS. Remote, macros, windows MSDOS \$139

SCIL - Source Librarian to manage Versions, Doc, Minimize disk space, confusion. MSDOS \$335

## "C" LANGUAGE

	OUR PRICE
MSDOS: C86-8087, reliable	call
Instant C - Inter. fast, full	495
Lattice 2.1 - improved	call
Microsoft C 2.x	329
Williams. debugger, fast	call
C Systems & debugger	175
CPM80 Ecosoft C-now solid, full	225
BDS C - solid value	125
MACINTOSH: Softworks	365
Megamax-object. full	295
Consular's MAC C	295
Compare, evaluate, consider other Cs	

## BASIC

	RUNS ON	OUR PRICE
Active Trace-debug	86/80	75
BASCOM-86 - MicroSoft	8086	279
BASIC Dev't System	PCDOS	115
Better BASIC - 640K	PCDOS	185
CB-86 - DRI	CPM86	419
Prof. BASIC Compiler	PCDOS	89
Databurst - screens	MSDOS	215
SCREEN SCULPTOR	PCDOS	115

Ask about ISAM, other addons for BASIC

## SERVICE

ALL PRODUCTS - We carry 700 products for MSDOS, CP M 86, CP M 80, Mac-Intosh and key products for other micros.

## EDITORS Programming

	OUR RUNS ON	OUR PRICE
BRIEF - Intuitive, flexible	PCDOS	195
C Screen with source	86/80	75
Epsilon - like EMACS	PCDOS	195
FINAL WORD-for manuals	86/80	215
MINCE-like EMACS	PC/80	149
PMATE-powerful	8086	185
VEDIT-full liked	86/80	119

## UNIX PC

	OUR PRICE
COHERENT - for 'C' users	PClike 475
COHERENT-NCI-Realtime	PClike call
XENIX - plus C to MSDOS	PC 1275

Ask about run-times, applications, DOS compatibility, other alternatives: UNIX is a trademark of Bell Labs

## LANGUAGE LIBRARIES

	OUR PRICE
GRAPHICS: GraphC-source in C	MSDOS 250
GRAPHMATIC-3D FTN. PAS	PCDOS 125
HALO-fast, full-all lang	PCDOS 145
FILE MGNT. B7rieve-all lang	MSDOS 215
Cindex + -source, no royal	86/80 375
CTree-source, no royal.	ALL 375
dBC ISAM by Lattice	8086 235
dB VISTA - "Network" Structure	MSDOS 465
PHACT-up under UNIX, addons	MSDOS 225
OTHER: CUII by Essential	MSDOS 139
Greenleaf - 200	MSDOS 149
CSharp - Real-Time	MSDOS 600
PORTABLE C to PC, Mac, II	Many 125
SOFT Horizons - Blocks I	PCDOS 139
SCREEN CURSES by Lattice	PCDOS 125
CView - input, validate	PCDOS 195
MetaWINDOW - icons, clip	PCDOS 139
PANEL - many lang. term	MSDOS 265
ProScreen - windows, source	PC DOS 415
Windows for C	MSDOS 175

## FORTRAN

	RUNS ON	OUR PRICE
MS FORTRAN-86 - Impr	MSDOS	\$ 239
DR Fortran-86 - full '77'	8086	249
PolyFORTRAN-XREF, Xtract	PCDOS	165

## OTHER PRODUCTS

Assembler & Tools - DRI	8086	159
Atron Debugger for Lattice	PCDOS	395
cEnglish - dBase to C	MSDOS	750
C Helper - DIFF, xref, more	86/80	135
CODESMITH-86 - debug	PCDOS	139
MacASM-full, fast, tools	MAC	115
MBP Cobol-86 - fast	8086	680
METAWINDOW - graph, fonts, clip	PCDOS	135
Micro: SubMATH-FORTRAN full	86/80	250
Microsoft MASM-86	MSDOS	125
MSD Debugger	PCDOS	119
Multilink - Multitasking	PCDOS	265
PC-FORTH -- well liked	MSDOS	219
PFIX-86 Debugger	MSDOS	169
PL 1-86	8086	495
Polylibrarian - thorough	MSDOS	95
PolyMAKE	PCDOS	95
PROFILER - flexible	MSDOS	125
Prolog-86-Learn, Experiment	MSDOS	125
SLK.F - Copy Protection	PCDOS	145
SYMD debugger-symbols	PCDOS	115
TRACE86 debugger ASM	MSDOS	119

Note: All prices subject to change without notice. Mention this ad. Some prices are specials. Ask about COD and POs. All formats available

Call for a catalog, literature, and solid value

# 800-421-8006

## THE PROGRAMMER'S SHOP™

128-B Rockland Street, Hanover, MA 02339

Visa Mass 800-442-8070 or 617-826-7531 MasterCard 8517

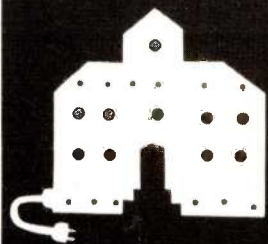

# C·O·M·P·U·T·I·N·G A·T· C·H·A·O·S· M·A·N·O·R

## Over the Moat

Golem Crashes

The Name Game

Copy-Protection Blues

The Elusive SI

Network Confusion

Great Software Purge

CP/M Bargains

BY JERRY POURNELLE

It's Christmastime at Chaos Manor, but you'd hardly notice it: there's a moat around my house. The City of Los Angeles has (finally!) come through with the building permit that lets us add a music room where the grapefruit tree used to be and a new library/office/workshop suite upstairs. The architects and contractors lost no time in breaking ground. My front door now opens on a four-foot trench. Of course, no sooner was the trench dug than we had the worst rainstorm in four years.

Amazingly, the mailman and other delivery people have braved the moat monsters, so there's plenty to write about.

### ONCE MORE INTO THE BREACH

One of the first people to find his way across the moat was someone from Federal Express: three enormous boxes from CompuPro—and on a Saturday yet.

It seems I had an interesting failure. CompuPro has had a small number of hard-disk drives crash. It was rare, and fixable by reformatting; but it annoyed Dr. Godbout because his people couldn't make it happen in the engineering labs.

Then it happened to me. I'd backed up all the files—I'm *very* paranoid about that sort of thing—so all I really needed to do was reformat, but I thought I'd call CompuPro first, since I had a couple of other things to talk about. I described my symptoms and lamented that I'd have to reformat.

"Don't touch it!" Bill Godbout commanded.

"Eh?"

"We've been trying to get that bug to bite something we have a complete history of. Box up the whole system, disk drives, computer, the whole works, and ship it up. Don't even turn it on again."

"Well, okay—"

"I'll swap you a new—well, nearly new—system."

That was an offer I couldn't refuse, so up it went, and on Saturday, a week before Christmas, there arrived a new System

8/16—with some differences.

My old CompuPro System 8/16, the Golem, had Qume DT-8 8-inch floppy disks. I may be one of the last people in the world to use 8-inch floppies, but I prefer them; they're noisy, but they're *far* more reliable than 5¼-inch, and each floppy holds 1.1 megabytes, enough for a whole novel. My Qumes worked fine, and I'd just taken them out to Xerox for routine servicing—something I recommend you do every couple of years. For \$60 (the minimum charge) they'll check the alignment, clean everything, and give you a complete report on any pending problems. Anyway, my disks had just returned when the CompuPro boxes arrived.

Qume no longer makes the DT-8 drives. CompuPro now sends half-height Mitsubishi double-sided double-density drives. They're just a little slower—4-millisecond (ms) stepping rate rather than the 3-ms rate of the Qumes—and you notice the difference, particularly when doing a Copy or Format operation. On the other hand, their major purpose is safety and backup, since the 45-megabyte hard disk is the major storage system for the 8/16.

The new Mitsubishi 8-inch floppies are incredibly quiet. CompuPro is using new and different fans, too; the result is that the new System 8/16, even with hard disk, makes less noise than Zeke II, the CompuPro Z80 (Qume 8-inch floppies, no hard disk) that I'm writing this on.

There were a couple of other surprises: instead of the three half-megabyte M-Drive/H RAM (random-access read/write memory) boards I used to have, there is now a single 2-megabyte RAM-disk board—and instead of two 5¼-inch disk drives, there's one 5¼-inch and one cartridge-tape backup. The cartridge will back up an incredible pile of files in a short time. If that seems vague, it's because I haven't read the specs; we simply turned it on and let fly, and as I write this it's backing up the main system track for my hard disk; the operation took about

(continued)

Jerry Pournelle holds a doctorate in psychology and is a science-fiction writer who also earns a comfortable living writing about computers present and future.



# COMPUTERS AND MORE

# CHALLENGE

- For Savings
- For Selection
- For Service
- For Corporations
- **FOR YOU!**

Putting the latest products and best prices in our customers' hands is our goal. We challenge any company to match our pricing, selection and service. Take the challenge & save!

## This Month's Special Saver!

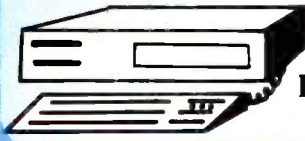

PC/AT Call!

### COMPUTERS

<b>IBM</b>	256K PC w/ 2 1550	<b>CORONA</b>	Desktop w/ 2 256K 1989
	PC-256K w/ 10 meg 2195		Portable w/ 2 256K 1795
	New PC JR ON SALE		
	New Models at CALL	<b>APPLE</b>	ON SALE
	XT w/ 2 drives 3495		MAC - All Models CALL
			Apple Entry Sys CALL
			Apple IIe CALL
			Call for Accessories
<b>LEADING EDGE</b>		<b>COMPAQ</b>	Portable 2195
PC 1 1395			Portable w/ 10 meg 3450
PC 2 1549			Desktop Models CALL
PC 4 1956			
PC 6 2695			
<b>NEC</b>	All Models CALL		
	8201A 389	<b>ZENITH</b>	151-21 1795
<b>TELEVIDEO</b>	1605 color 2350		151-52 3490
	1605 20 meg color 3990		161-21 1990
	PM-16 & PM4 CALL	<b>AT&amp;T</b>	All Models CALL
<b>COLUMBIA</b>	MPC 4210 1895	<b>SANYO</b>	MBC 775 2250
	MPC 4220 1989		MBC 550 ON
	MPC 4620 3359		MBC 55 SALE
	MPC 4820 3795		MBC 550-2 NOW!
	MPC 4750 4129		
	UP 2220 2059		

### ACCESSORIES

<b>For IBM JR, PC/AT</b>	<b>For APPLE 2/ MAC</b>
AST MP Mini ON	MAC Phone 144
AST I Q Mini SALE	Kensington Port Modem 109
AST Advantage CALL	5.5 Omni drive 1450
AST MegaGraph+ FOR	11.1 Omni drive 1990
AST Graph Pak 64 PRICE	MAC drive 5 meg 1650
Promodem 1200 349	MAC 10 meg fixed 1639
US RO 1200 349	AST Multi I O CALL
Hayes 1200B 379	Videx Videoterm 179
320K drive 159	Hayes Micro IIe 229
1/2 height Teac 149	Hayes IIc 254
Auto boot 10 meg 749	Nova 212 399
Fuji DS DD (box) 21	MAC cat 359
Paradise Mod. Graf 294	IIc drive 189
New XP Quad 64K 239	Apple drive 159
Quad 512 249	Micro soft CALL
Hercules color cd 179	AppII card 4 125K 369
Hercules GRFX cd 349	AppII card 6-128K 429
Tecmar GRFX mast 489	Microbuffer II+ 194
Jedmat PC JR's CALL	Promodem IIc 359
Vutek Best Buy! 239	Promodem MAC 369

### PRINTERS

<b>JUKI</b>	6100 389	<b>CITIZEN</b>	MSP-10 359
	6300 699		MSP-15 499
	6100 tractor 109	<b>NEC</b>	
<b>EPSON</b>	LQ 1500 1049		8050 Models CALL
	RX 100 389		Pinwriter 2 499
	RX 80 219		Pinwriter 3 769
	JX 80 color 559		2030 PAR 779
	FX 100 589		2050 PAR 889
<b>DAISYWRITER</b>	Daisy 2000 839		3510 1299
	Daisy M45 CALL		3515 1325
			3550 1499
<b>PANASONIC</b>	1090 219	<b>STAR</b>	Delta 10 339
	1091 279		Delta 15 469
	1092 399		Radix 10 494
	1093 589		All Models CALL
	Ribbons (w/ purchase) 8	<b>OKIDATA</b>	OKI 92 MAC 449
<b>TOSHIBA</b>	P 1351 Por S 1259		OKI 93 MAC 729
	P 1340 Por S 749		84 P CALL
<b>QUADRAM</b>	Quadjet 695		02 P CALL
	IBM kit 19		2350 CALL
			2410 CALL
			All Models ON SALE

### MONITORS

Roland DG-121-G 139	Quadscreen w/Card 1650
Roland DG-121-A 249	Zenith 131 319
Roland CB-141 319	Zenith 135 487
Roland CC-141 595	Zenith 122 109
Taxan 420 389	Amdek 310 159
Taxan Amber 119	Amdek Color IV-T 597
Taxan 415 499	Amdek 300 G 134
TGB-80 col IIe 139	Amdek 300 A 144
RGB Card IIe 89	NEC JC 1215 269
Quadchrome 559	NEC JC 1216 397

### SOFTWARE

<b>FOR PC &amp; XT</b>	<b>APPLE</b>
OZ by Fox & Geller 299	dBase III by Ash/Tate 419
Quick Code 219	Friday by Aston-Tate 199
FrameWork by SALE!	Bottom Line Strategist 269
dBase III 419	C Dex Packages (ea) 39
Friday 199	CPA Modules I thru 4
Please by Hayes CALL	(each) 174
Lotus 1-2-3 275	OZ by Fox & Geller 319
Mayday by Teletek CALL	Graphox 197
Symphony by Lotus SALE	Sales Edge 174
Upgrades for 1-2-3 CALL	Format II 104
DESQ CALL	Knoware 64
Invest Anyl by Dow Jones	Master Type 27
Market Analyzer 249	Micro Pro CALL
Market Manager 219	Micro Soft CALL
PFS: Access 65	PFS: Access IIe 49
PFS: File 89	PFS: File II 84
PFS: Write 89	PFS: File IIe 84
PFS: Report 84	The Handlers (all) 149
Bankstreet Writer 47	Terapin Logo 99
EasyWriter II by IUS 269	VersaForm 259
Dow Jones Soft CALL	BPI GL 267
Volkswriter Delux 179	Pie Writer by Hayden 97

## CHAOS MANOR

four minutes to store 2.1 megabytes of commands and data, a full 191 files.

Before I got the hard disk, I didn't think I needed one; now I can't imagine how I got along without it. I suspect the same will be true of the tape backup unit.

The new system came with yet another revision of the CP/M 8/16 BIOS (basic input/output system) software, which gets more sophisticated all the time. I guarantee you there will be at least one more change before you read this: just at the moment, if you try to get a "DIR L:" of the tape backup cartridge, the machine locks up so thoroughly that not even Reset will save it; we had to turn it off and back on again. That's going to be fixed. WRITE, the text editor I use, can automatically recover any text still in memory or on the RAM disk; but nothing unsaved will survive power-down.

Understand, there is software for getting the tape's directory; and I don't expect it to take them long to come up with a way to recover from "DIR L:"...

## NAMES, NAMES, NAMES

CompuPro has a problem: every now and again someone looks up the company's financial rating and mistakenly finds the entry for CompuCorp. CompuCorp is almost out of business and didn't do very well in the last year it got rated. CompuPro has actually lost sales because of this. The telephone receptionist is also getting weary of calls for "CompuPoo."

Thus began the great name hunt. CompuPro engaged consultants and did market research. Eventually they selected a name and kept it secret until they completed all the legal work to protect the trademark.

"It used to be," Bill Godbout said, "that you'd consult soothsayers and examine chicken entrails before undertaking something new like getting married or changing the company name."

"You're doing both—"

"Yes, and now you consult lawyers. They told me I'd be crazy to marry this year. Something about taxes. Next year. They've also approved tell-



CALIF. Sales Office

1-800-433-9449



NEVADA Sales Office

1-800-621-0852 ex 988

Equipment subject to price change and availability.

NOW SERVING YOU FROM OUR NEW NEVADA LOCATION

No Sales Tax

COMPUTERS and MORE THE CHALLENGERS!

8265 Commercial Dr., La Mesa, CA 92041  
680 Greenbrae Drive #234, Sparks, Nevada 89431



ing you the new name. CompuPro is now Viasyn."

"Viasyn?" I asked. I didn't say it sounded like a medicine. "Why?"

"Everyone can spell it. You studied Latin. Via for way, syn for synthesis..."

CompuPro began as CompuKit back in the days when kit sales were usual in the micro business. (Ezekial, my first friend who happened to be a Z80, began life as Cromemco kits.) When Godbout began to sell assembled and tested gear, the company name was changed to reflect that.

"Why not Godbout Computers?" I asked.

"Market research says some customers think it's blasphemous."

"It's your name—"

"Yeah, I know. Anyway, it's Viasyn."

Oh, well. I suppose I'll get used to it. Meanwhile, I suppose I must have collected, over the years, about a dozen letters complaining about my practice of naming my machines. Some readers are mildly annoyed, particularly if they tuned in late and can't figure out which machine I'm writing about—a legitimate complaint, and I'll try to do better in future.

Others are actually furious. One poison-pen letter—unsigned, of course—invited me to do obscene things with Adeline and dared me to print the letter.

My new 8/16 hasn't told me its name yet. I expect I'll learn pretty soon.

**WHO CARES?**

Suddenly everyone is talking about Framework vs. Symphony; which is better? It's the great software face-off, and every magazine I pick up has an article on the subject. The Ashton-Tate and Lotus PR people must have been working overtime to gin up all this interest.

As for me, I couldn't care less. I'm not likely to use either one. Or see below: if I do, I'm illegal.

**THE COPY-PROTECTION PLAGUE**

Both Symphony and Framework are copy-protected. I'm not about to entrust anything vital to a copy-pro-

*(continued)*

# FREE high tech catalog



Most accurate Clock



Computerized weather station



Low-cost audio spectrum analyzer



IBM-compatible computers, peripherals, software



Ham radio gear of every type



HERO® robots and robotics training



Microprocessor trainer and courses

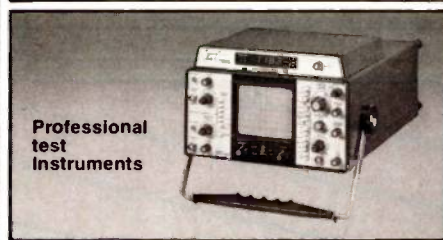

Professional test instruments

**A trustworthy guide to what's new in electronics and computers.**

For many years the illustrated Heathkit Catalog has been a guide to new and exciting kit products for people like you to build. To enjoy and learn from them, while saving money in the process. What sets the Heathkit Catalog apart is its range of high quality products and accurate information to help make your buying decisions easy. If you've never tried kit-building, you have an absorbing new experience in store as you create products you'll take pride in.

**Send for free catalog** If coupon is missing, write Heath Company, Dept. 334-282, Benton Harbor, Michigan 49022



Mail to: Heath Company, Dept. 334-282  
Benton Harbor, Michigan 49022

Please send me my **FREE HEATHKIT CATALOG.**

Name \_\_\_\_\_

Address \_\_\_\_\_

City \_\_\_\_\_ State \_\_\_\_\_ Zip \_\_\_\_\_

Heathkit products are also displayed, sold and serviced at 64 Heathkit Electronic Centers nationwide. Consult telephone directory white pages for location. Operated by Veritechnology Electronics Corporation, a wholly-owned subsidiary of Zenith Electronics Corporation. CL-778C





**PROFESSIONAL PROGRAMMER'S BULLETIN:**

# Be Productive, Be

# BRIEF™

The Programmer's Editor

TRY BRIEF RISK-FREE  
FOR 30 DAYS WITH  
OUR MONEY-BACK  
GUARANTEE!

BRIEF's power and flexibility provide dramatic increases in programming productivity. BRIEF's ergonomically designed human interface becomes a natural extension of your mind, allowing you to eliminate tedium and concentrate on creativity.

- WINDOWS
- Full UNDO (N Times)
- Compile within BRIEF
- Keystroke Macros
- Exit to DOS inside BRIEF
- Programmable Macro Language
- Multiple files, unlimited size
- "Regular Expression" search
- Reconfigure keyboard
- Language sensitive user controllable features (such as Auto-Indent for C)

AVAILABLE FOR PC-DOS, IBM-AT, AND COMPATIBLE SYSTEMS

**ONLY \$195.**

DEMO AVAILABLE FOR ONLY \$10 (applicable to future purchase)

CALL TOLL FREE  
800-821-2492

for "Technical Description" or to order.

**Solution Systems™**

335-B Washington St., Norwell, MA 02061  
617-659-1571

BRIEF is a trademark of UnderWare.  
Solution Systems is a trademark of Solution Systems.

**CHAOS MANOR**

tected program, since, if I do, sure as anything the master disk will get lunched just after 5:00 p.m. on the Friday prior to April 15th.

I'm not familiar with Symphony's scheme; for some reason, I don't at the moment have a copy. I do have Ashton-Tate's new programs: Framework and dBASE III. They both use the Prolok copy-protection system. The company that provides it is the Vault Corporation, which is owned in part by Ashton-Tate.

The dBASE III documents come with an errata sheet that tells you: "You have been provided with two original system diskettes in your dBASE III package. Your SYSTEM diskette and its backup are not identical to each other. Each diskette has a unique identity just like a human fingerprint. Therefore, a backup copy from *one original* diskette will not boot up a copy you make of the *other original* SYSTEM diskette.

"When you boot up your system, be sure that you are using the same original diskette from which you made your backup copy."

There's also a warning: "Never use the DISKCOPY command to copy the dBASE III files to the new diskettes; use the COPY command instead. Use of DISKCOPY will result in permanent damage to your master diskette."

It does, too. You are urged by Ashton-Tate to make a "backup" copy of your dBASE III system disk; you can then use the "backup" for everything, except that when you start up dBASE III you have to have the original system disk in Drive B until the program is satisfied. If you use Diskcopy to copy the original system disk, then when you try to invoke the program your efforts are met with the message "unauthorized copy;" and failure—even though you're using the original system disk. I'm not sure how Ashton-Tate's people have managed that result: one would think that a Copy utility couldn't be induced to *write* onto a source disk—but apparently they've done it.

This makes me wonder: presumably they've come up with some way to alter the Diskcopy utility; do they then

## IF POWER FAILS, DATASAVER® TAKES OVER!

**PROTECTION** – saves data during power failures.  
– saves hardware from overvoltage transients.

**PORTABILITY** – allows mobile or extended holdup time using auxiliary 12 volt battery.

**FEATURES** – internal battery provides 5 min. + operating time – AC line conditioning  
– audible and visual alarms, interrupt signal – compact, desktop styling  
– no installation required.

200 WATT — \$495 / 90 WATT — \$350  
For special applications and product information, call 805-541-4160.

Instant power order line  
**805-541-4161**

**CUESTA SYSTEMS, INC.**  
3440 Roberto Court, San Luis Obispo, California 93401

**INSTANT AC POWER**



## CHAOS MANOR

restore it when they're done mucking about with it? Or have they some crazy file that ought not be copied, and copying it moves it to a different location? I suppose I could figure out how they do it, but I can't make myself care enough.

Incidentally, a number of sources tell me that in PC-DOS the Copy utility is much more reliable than Diskcopy. Again, I don't know why. I find some of the "features" of PC-DOS incomprehensible anyway, and I've never understood why they don't have an obvious equivalent of CP/M's SYSGEN utility, which puts the operating system onto otherwise blank disks.

In any event, the copy-protection nonsense has kept me from experimenting with either Framework or dBASE III. One of these days, I'll get a Copy utility that will let me make backups and put dBASE III on a hard disk, after which I'll take it seriously, or else I'll get around to installing demons to defeat the Prolok scheme.

A demon is a small program that sits in high memory, watches what the Prolok scheme wants, remembers it, and later intercepts the Prolok disk calls to give Prolok what it wants to hear. Demons are not particularly hard to write, and they'll do a good job on many copy-protection schemes.

Until I get the copy protection defeated, though, those programs go back on the shelf; I'll review them some time when things are slow.

### FASCINATING

One of my correspondents tells me that Prolok works in mysterious ways. It tries to conceal itself: 99 percent of the Prolok code doesn't exist until the program is loaded and running, at which time it goes through a complex process of decryption that's designed to be difficult to trace.

My correspondent, using PC Trace hardware, was able to follow what was going on—and discovered that Prolok has pulled in about 700 bytes, nearly 10 percent, of the IBM PC's ROM (read-only memory) BIOS code pertaining to disk-control functions.

Is this a copyright infringement? IBM has certainly taken action against other companies making free with its ROM BIOS code.

There's a more serious problem.

Ashton-Tate has sent a notice that it expects to have a copy-protection scheme that lets you put its copy-protected software onto your hard disk.

I know of no way to "protect" code on a hard disk without *reformatting* one or more sectors of that hard disk; or doing something equally drastic, like hiding deleted data address markers or some such. The scheme would involve doing "secret" things to your disk that only the program knows about.

Anyone who lets Ashton-Tate, or Vault, do that to their hard disk has got to be out of their ever-loving blue-eyed mind!

Actually, I'm not sure we wouldn't be better off if all users took the pledge: except for games, we will not buy copy-protected software. If a significant number of us do that, and we can get the other writers to push this stand, we can exorcise the copy-protection devil once and for all.

Even if you're not prepared to go that far, Lotus 1-2-3 plus Borland International's Sidekick (the \$79.95 version that isn't copy-protected) has most of the features of Symphony and nearly as many as Framework; and if you already have Lotus 1-2-3, it's a lot cheaper.

### UNLOCK IT

There's another solution to the copy-protection plague: programs that enable you to back up copy-protected disks. The best general-purpose backup utility we've found for the PC is System Backup from Norell Data Systems. Be sure to get the latest version; the utility changes with the times. However, *no* general-purpose Copy scheme will defeat all the different copy-protection schemes, and the latest version of System Backup will *not* copy dBASE III.

However, a number of Copy utilities, including one for dBASE III, have ap-

(continued)

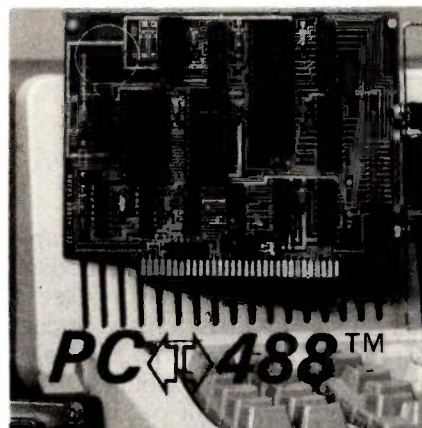

## An IEEE-488 interface for all IBM-PC's and COMPATIBLES

### VERSATILE

Easy-to-use commands for all IEEE-488 (GP-IB, HP-IB) functions.

Resident firmware supports **BASIC, Pascal, C, and FORTRAN.**

Emulates Hewlett-Packard controller functions and graphics language statements.

Supports Tektronix® Standard Codes and Formats.

Print listings, plot graphs, and use **Lotus 123™** with IEEE-488 peripherals.

### FAST

Direct memory transfer rates to 800K bytes/second.

### PROFESSIONAL

Clear and concise documentation includes a complete tutorial, programming examples, and application programs.

**\$395.00 complete.** There are no additional software charges.

Find out why **PC 488** is the first choice of over 500 companies.



## CAPITAL EQUIPMENT CORP.

10 Evergreen Avenue  
Burlington, MA. 01803  
(617) 273-1818

IBM is a trademark of International Business Machines Corp.  
Lotus 123 is a trademark of Lotus Development.  
Tektronix is a trademark of Tektronix, Inc.



peared on public-service electronic bulletin boards. If you have a modem, time, and patience, you can collect a fair number of them for free (except for the phone bills). You could also buy these from user groups, except that user groups put out their free software more or less in the chronological order they received it, so that you'll have to buy a number of disks in order to collect all the different copy-protection breakers. If you do buy a lot of user-group disks, be warned: an awful lot of "free" software doesn't work very well or do anything rationally useful.

Another alternative is to buy one of Workman's utility disks. Barry Workman collects public-domain software, tests it (but not extensively), edits the documents, and collects the stuff he thinks useful onto one disk. At last count he had six disks of CP/M utilities and at least one disk of MS-DOS stuff.

His CP/M Disk Six contains over 200K bytes of stuff. One program, Edfile, is worth the price of the whole lot. Edfile allows you to edit disk files; you can go in and change things, such as long, boring messages. (It is probably illegal, and certainly unethical, to use Edfile to remove copyright notices and serial numbers.) Edfile combines the best features of Spat and Duu (earlier disk-file editing programs) with some of the good features of DDT and Ed. I'd think anyone with an 8-bit (or 8/16) CP/M system would want this one.

Workman's MS-DOS Disk One contains all the copy-protection information he has found recently: some executable programs and some documentary files that suggest patches to remove copy protection. About half the programs on the disk are specific to the IBM PC and 100 percent compatibles; the rest are generic MS-DOS.

Do understand that most of these programs are available free if you look hard enough for them.

### A Z80 MODULA-2

Workman has recently concluded an agreement whereby he will be dealer for a Zurich programmer who has developed a native-code Modula-2 compiler for Z80 CP/M machines.

It is a four-pass compiler: that is, it's pretty slow. At present it has no floating point, open arrays, or built-in error procedures (that is: when an error is detected, an error-message file has to be called in to tell you what happened). There's no procedure type—i.e., you cannot pass a procedure name as a parameter in a procedure call.

If you're not a programmer, you'll hate the manual; but all the information you really need is in there, if you know what to look for.

## COMPETITIVE EDGE

P.O. Box 556 — Plymouth, MI 48170 — 313-451-0665

Compupro®, LOMAS, EARTH, TELETEK, Macrotech  
**S-100 CIRCUIT BOARDS**

CompuPro 286 CPU**	\$695	Lomas 286	\$821	Macrotech 286 Z80H	\$995
CompuPro SPU Z**8MHz	261	Lomas 8086	420	Lomas 10MHz 8086	520
CompuPro 8085/86**	327	Lomas Octaport**	320	Lomas 4 serial	200
CompuPro Disk 1A**	459	Lomas LDP**	206	Macrotech 256K Dram	499
CompuPro Disk 2**	525	Lomas 256K Dram	446	Macrotech 512K Dram	799
CompuPro Ram 22**	995	Lomas 512K Dram	821	Macrotech 512K static	1699
CompuPro Ram 23**	308	Lomas Ram 67**	725	Macrotech 256K static	995
CompuPro Ram 23 128	555	Lomas Hazitail**	244	Lomas Color Magic** 16K	476
CompuPro CPU Z**64K	215	Thunder 186**	1095	Lomas MSDOS** 2.11	225
CompuPro CPU/M*816*	250	Lomas CCP/M*86**	280	CompuPro MDrive H*512K	495
System Support One**	297	CompuPro I/O 4	297	CompuPro I/O 3 8 port	459
Teletek HD/CTC	525	Teletek SBC 1	525	Teletek SBC 1 6MHz 128	699
Teletek Systemmaster*	557	Systemmaster II*	899	Turbodos* for Teletek	650

**Earth Computer TURBO SLAVE I 8MHz 128K \$395.**

Turbo Slave I runs with Teletek, North Star, Horizon, Advanced Digital and Others.

### SYSTEMS

CompuPro 286, SS1, I/O 4, Disk 1A, Disk 3, 40MB HD, 512K, 15 Slot 5" CCPM	5495
Lomas 286, Hazitail, LDP 72, 512K, 40 MB, 1-5" Flop, 4 port, 15 Slot, CCPM	5495
Lomas Thunder 186, 512K, 4 Slot, 10 MB HD, 4 Serial, CCPM, 1-5" Floppy	3995
CompuPro 8085/86, I/O 4, Disk 1A, Ram 23, 10 Slot, 2-8" Drives CP/M 2.2	2895
CompuPro CPU Z, I/O 4, Disk 1A, Ram 23, 10 Slot, 2-8" Drs, CP/M 2.2	2795
Teletek Systemmaster II, 8MHz Z80, 128K, 10 Slot 2-8" Single Turbodos	2695
Teletek Systemmaster, 4MHz Z80, 64K, 10 Slot, 2-8" CP/M 2.2	2095
Systemmaster II, 10MB HD, 1-8", 10 Slot, 4 HI Speed 128K Slaves	4995

### CABINETS

Para Dynamics 20 Slot Pronto	\$1195	Para Dynamics 2300D Flyp HD CAB	\$395
Para Dynamics Mini Pronto	795	Para Dynamics 2200 Rack Drive CAB	495
CompuPro Enclosure 2 Desk Cab	611	CompuPro Enclosure 2 Rack	645

### TERMINALS & PRINTERS

Qume 102 Amber	495	Data Products 8010	\$495	DP 8020	\$625
C. ITOH 8510A	350	C. ITOH 8510 Serial	455	C. ITOH 1550 P	550
C. ITOH 1550 BCD	650	C. ITOH 8510 SP	475	C. ITOH 8510 SR	550
C. ITOH 1550 SP	695	C. ITOH 1550 SR	725	C. ITOH 8510 SCP	550

ALL PRICES SUBJECT TO CHANGE AND STOCK ON HAND

CompuPro is a Registered Trademark of Visiyn. CPU Z, Disk 1A, Disk 3, Interface 3, CPU 286, CPU 8085/86, System Support 1, MDRIVE-H, Ram 22, Ram 23 are trademarks or registered trademarks of Visiyn. CP/M 2.2, CCPM, are registered trademarks of Digital Research Inc. MSDOS is a registered trademark of Microsoft, Systemmaster & Systemmaster II are registered trademarks of Teletek Enterprises. Turbodos is a registered trademark of Microsoft.

## HARMONY VIDEO & COMPUTERS

2357 CONEY ISLAND AVE. BROOKLYN, NY 11223  
800-VIDEO84 OR 800-441-1144 OR 718-627-1000



**COMMODORE 64**  
\$149.95  
**APPLE 2E w/DRIVE**  
\$839.95

**APPLE 2C**  
\$889.95  
**GEMINI SG 10**  
\$215.95

### "PRINTER SPECIALS"

Anadex	1034	Epson FX 100+	583	Okimate 10	127
Brother HR15 XL	349	Epson LQ 1500	998	Olympia ro	304
Brother HR 35	777	Gemini Sg 10	216	Panasonic KXP 1091	255
Brother Keyboard	129	Gemini Sg 15	352	Panasonic KXP 1090	169
Citizen MSP 10	329	HP Laser Jet	2678	Panasonic KXP 1092	379
Citizen MSP 15	488	Juki 6100 Teletideo	371	Panasonic KXP 1093	562
Corona Laser	2369	Juki 6300	739	Panasonic KXP 3151	450
Daisywriter	739	Mannesman Spirit 80	183	Powertype	279
Delta SD 10	352	Mannesman 160L	529	Quadjet	720
Delta SD 15	431	Mannesman 180L	739	Radix SR 10	461
Diablo 620 API	678	NEC 2050	639	Radix SR 15	576
Dynax DX 15 XL	342	NEC 3500	1297	Riteman Blue +	220
Epson RX 80 FT +	285	NEC 7730	1629	Silver Reed Exp 550	378
Epson RX 80	226	NEC 8850	1679	Silver Reed Exp 500	286
Epson RX 130	374	Okidata 92	349	Silver Reed Exp 770	704
Epson FX 80	394	Okidata 93	564	Toshiba 1340	678
				Toshiba 1351	1213

## WOW! WOW! WOW!

APPLE		IBM		MONITORS	
2E w/Idisk Drive	834	PC w/Drive	1449	Amdek 300 Green	114
Macintosh	1679	PC XT	3089	Amdek 300 Amber	121
Apple 2C	887	PC Portable w/Drive	CALL	310 Amber	142
Imagewriter	473	AST Six Pack	239	Color 300	221
Addl. Drives	from 114	Taligrass 20 Meg	2374	Color 500	324
		Quad Board	224	Color 600	384
		Keytronics	159	Color 700	452
		Hercules Color	153	Color 710	519
		Hercules Monochrome	294	Taxan 210	199
		Persy's Color Card	148	Princton HX12	145
		Persy's Monocard	162	Taxan 122A	139
		Plantronics	409	Taxan 420	394
		PC w/10 Meg Hard Dr.	2399		
		Bernoulli Box	1999		
		10 Meg Drive	899		
ATARI		ZENITH		SANYO	
800 XL	109	Zenith PC 2150	1631	550 D.S.	649
1027 Printer	224	Zenith PC 15152	2076	555 D.S.	974
1050 Drive	159	Zenith PC161-52	2244	CRT 70	509
Indus. Drive	224				
1025 Printer	169				
MODEMS		COMMODORE			
Hayes 1200	431	Commodore 84	149.95		
Hayes 1200B	378	1541 Disk Drive	184		
Hayes 300	184	1702 Monitor	189		
Micromodem 2E	212	MPS 802	188		
Access 123	359				
Novation J-cat	89				

800-441-1144

Items reflect cash discount. For your protection we check for stolen credit cards.

This is a programmer's Modula-2. Unless you're a fanatic, it's not something to learn the language from. However, it is Modula-2 for the Z80, and it does compile executable programs. The Zurich people are working on adding the floats, error procedures, and procedure types (in that order).

Recommended for hackers only.

**SI EXISTS**

For over a year I've heard stories about the SI operating system. It is supposed to be totally portable, multi-tasking and multiuser, and better and friendlier than UNIX. It will contain the perfect programming language, enable but not require virtual memory and memory management, control any computer, right any wrong, dream the impossible dream...

SI was said to have been created by a Princeton faculty member and

would be marketed by Multi Solutions Inc. (MSI) of Lawrenceville, New Jersey. Frankly, it sounded like a scam, and my views weren't changed when I found an MSI booth at a show last year and was told they didn't have a demonstration because their computer was lost on a truck or something. They've since told me they don't really like to ship computers around to shows because the machines often don't do well after transportation; but that wasn't what I heard at the time.

Also, MSI's literature seemed outrageous. They claim: "Only SI Vendors and Users will survive the next revolution." They offer a *huge* range of products, languages, and compilers that I am certain do not exist. Then I met one of the company's representatives. He's one of those chaps who gets too close to you and talks 50 miles a second. He promises any-

thing, and you don't even get Arpege. After five minutes with him, I was sure it was all a scam. Just to be safe, I sent a message through the net asking if anyone had ever seen SI in operation. None had, but some had met the sales chap who so negatively impressed me; and everyone who had met him, including senior CompuPro officials, came to the same conclusion. SI was vaporware and likely to remain so.

We were wrong. SI exists.

The SI operating system was displayed in a small booth down at the far end of the main hall at COMDEX. The instant I came around I was seized; Robert Knight, formerly of Princeton's computer laboratories, is an old fan of my books and columns as well as the creator of SI, which he had running on an IBM Instruments CS9000 (the processor is a 68000);

(continued)

**NEW!**

**THE UPS THAT TALKS TO YOUR COMPUTER.**

**MICRO-FERRUPS™**

**TOTALLY EFFECTIVE POWER PROTECTION**  
Protects against blackouts, brownouts, spikes, sags, surges, glitches, noise and frequency shifts. Provides computer grade sine wave power.

**TRUE NO-BREAK UNINTERRUPTIBLE POWER**  
MICRO-FERRUPS provides true no-break uninterruptible power. (Many UPS on market are really standby systems that break power from 2-10 milliseconds when transferring to battery backup. That's an eternity to your computer and disk drive.)

**BATTERY INCLUDED**  
Sealed no-maintenance, long life battery included. An auxiliary 12 volt battery can be added for longer backup time.



**250VA \$945**  
**500VA \$1345**

**TALKS TO COMPUTERS**  
The on-board microprocessor and RS232 port allows MICRO-FERRUPS to interface with computers. Your power can be monitored by the computer so you know what is happening and an orderly shutdown can be made. AC input and output voltages, output current, load VA, line frequency, battery voltage and backup time remaining can be displayed on terminal. 300 or 1200 selectable baud rate. ASCII.

**BEST POWER TECHNOLOGY, INC.**  
P.O. BOX 280, NECEDAH, WISCONSIN 54646

**800-356-5794**  
Wis. 608-565-7200

**PROLOG-86™**

**Become Familiar in One Evening**

Thorough tutorials are designed to help learn the PROLOG language quickly. The interactive PROLOG-86 Interpreter gives immediate feedback. In a few hours you will begin to feel comfortable with it. In a few days you are likely to know enough to modify some of the more sophisticated sample programs.

**Sample Programs are Included like:**

- an EXPERT SYSTEM
- a NATURAL LANGUAGE INTERFACE (it generates a dBASE II "DISPLAY" command)
- a GAME (it takes less than 1 page of PROLOG-86)

**PROTOTYPE Ideas and Applications QUICKLY**

1 or 2 pages of PROLOG is often equivalent to 10 or 15 pages in "C" or PASCAL. It is a different way of thinking.

Describe the FACTS and RULES without concern for what the computer will have to do. Maybe you will rewrite in another programming language when you are done.

**Programming Experience is not required** but a logical mind is. PROLOG-86 supports the de facto STANDARD established in "Programming in Prolog."

**CONTEST:** Win \$1,000. Ask about it. Deadline of 4/30/85.

**AVAILABILITY:** PROLOG-86 runs on MSDOS, PCDOS or CPM-86 machines. We provide most formats. The price of PROLOG-86 is only \$125.

**Solution Systems™**

335-B Washington Street  
Norwell, MA 02061  
**617-659-1571**

Full Refund if not satisfied during first 30 days.  
**800-821-2492**



# Circuit-Board-Design Without the Tedium

smARTWORK™ lets the design engineer create and revise printed-circuit-board artwork on the IBM Personal Computer.

Forget tape. Forget ruling. Forget waiting for a technician, draftsman, or the CAD department to get to your project. smARTWORK™ software turns your IBM Personal Computer into a professional, high-quality drafting tool. It gives you complete control over your circuit-board artwork — from start to finish.



smARTWORK™ transforms your IBM PC into a CAD system for printed-circuit-board artwork. Display modes include both single-layer black and white and dual-layer color.

What makes smARTWORK™ so smart is that it understands electrical connections. Conductor spacing is always correct, lines don't become too narrow, and connecting lines do not intersect other conductors. smARTWORK™ can automatically find and draw the shortest route between two conductors. Or you can specify the route.

smARTWORK™ is the only low-cost printed-circuit-board artwork editor with all these important advantages:

- Complete interactive control over placement and routing
- Quick correction and revision
- Production-quality 2X artwork from pen-and-ink plotter
- Prototype-quality 2X artwork from dot-matrix printer
- Easy to learn and operate, yet capable of sophisticated layouts
- Single-sided and double-sided printed-circuit boards up to 10 x 16 inches
- Multicolor or black-and-white display
- 32 user selectable color combinations; coincident points can be displayed in contrasting colors.
- Can use optional Microsoft Mouse as pointing device



Twice scale hardcopy of your artwork is produced using the Epson dot-matrix printers or the Houston Instrument DMP-41 pen-and-ink plotter. Quick 1X check plot is also available from Epson printers.

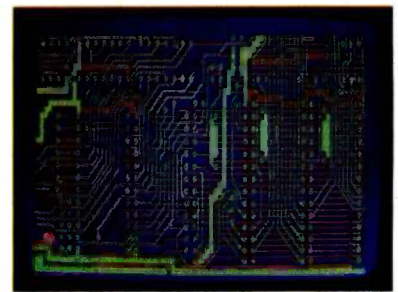

Dual-layer color display of a 2" by 4" section of a 10" by 16" circuit board

## The Smart Buy

At \$895, smARTWORK™ is an exceptional value, particularly when compared to conventional engineering workstation costs.

Call or write us for more information on smARTWORK™. We'll be glad to tell you how smARTWORK™ helps us design our own circuit boards and what it can do for your business.

Send a purchase order, or major credit card number, and smARTWORK™ can be working for you next week.

## System Requirements

- IBM PC or XT with 192K RAM, 2 disk drives and DOS Version 2.0
- IBM Color/Graphics Adapter with RGB color or b&w monitor
- Epson MX-80/MX-100 or FX-80/FX-100 dot-matrix printer
- Houston Instrument DMP-41 pen-and-ink plotter (optional)
- Microsoft Mouse (optional)



"smARTWORK" and "Wintek" are trademarks of Wintek Corporation.

that's a machine I'm not familiar with. There was also a Stride 440 (formerly Sage IV, also a 68000 machine), and I'm told they have a CompuPro 68000 back in New Jersey.

I got a demonstration. Of course, you can't see much at a show; there are constant interruptions. Thus, I still don't know a lot about SI. It certainly runs. It has features not present in CP/M 68000; features I'd very much like to have. It's said to be highly portable, and thus soon able to run on the 80286 and 32016 chips as well as the 68000. I'd like to see Knight get together with a good hardware house that produces machines running with a wide variety of processor chips and implement this properly. It just might be the wave of the future. Lord knows I'd be glad to learn one multitasking multiuser operating system that I could use on a lot of different machines. I'm not very keen on UNIX; at

the moment, the up-and-coming operating system seems to be Concurrent DOS, and I don't know when they'll have that for 68000-based machines.

Knight claims a lot for SI. The MSI ad sheet gives prices for FORTRAN, C, Pascal, BASIC, etc., etc., but they didn't have them at COMDEX; MSI claims Pascal, FORTRAN, and C by the spring of 1985, but the only language they have so far is MSI's own SI, a kind of stripped-down Pascal. Until they have languages, SI isn't going anywhere.

I liked Robert Knight. He was perfectly honest with me on every question I asked, made no claims he wasn't ready to demonstrate, and thoroughly understood my skepticism. They're going to send a copy they claim will run on my CompuPro 68000 system. When I have it, we'll see. I don't do reviews until I have it

*The world is ready for another operating system.*

running here at Chaos Manor.

Knight claims to have SI 90 percent finished. I suspect the rest will take longer to hack than he thinks. (Alex repeats an old motto: the first 90 percent of the work takes 50 percent of the time, and the last 10 percent takes the other 50 percent of the time.) However, Knight just might be able to bring it off. If he does, the potential is high. The world is obviously ready for another operating system; UNIX isn't going to do the job (it's a Thursday night so I can say that). Digital Research is in the doldrums. MS-DOS

(continued)

Come visit us in our Long Island Showroom  
226 Sherwood Ave.  
Farmingdale, NY 11735

# Computer Channel

Se Habla Español  
1-800-331-3341  
Cable: COMSYSTEC NEWYORK  
Telex: CSTNY 429418

---

**OUR SPECIALTY: IBM COMPATIBLE PRODUCTS, GRAPHICS, DATABASE, 68000 UNIX, EXPORT**

<p><b>IBM AND COMPATIBLE BUSBOARD WITH SOCKETS FOR 512K RAM</b> .....\$169                  Async I/O .....\$88                  Parallel I/O .....63                  Clock Calendar .....69                  Game I/O .....69                  Floppy controller .....160                  Monochrome adaptor .....190                  16 channel A/D .....110                  8-bit I/O module .....69</p> <p><b>IBM AT ADD ONS</b>—Latest and best IMC 20 and 40 M-Byte Drives                  Multifunction board—to 4 Meg RAM, 4 serial ports, parallel, game ports—Call                  AT 1.2 Meg Diskettes—\$6.45 ea.</p>	<p style="text-align: center;"><b>ACCESSORIES</b></p> <p>3 COM NETWORKING ETHERLINK .....\$650                  IBM PC 1 or 2 to XT upgrade ROM BIOS ...119                  TAVA and PC COMPATIBLES 2.0 UPGRADE ROM .....85                  5 1/4 DSDD DISKETTES—\$1.49 ea.                  10 MEG HARD DISK WITH CONTROLLER .....\$795                  IN CASE WITH POWER SUPPLY, CABLES, ETC. ....1095</p> <p style="text-align: center;">PRINTERS—CALL FOR OTHERS                  C. ITOH • F10-40P • \$947.70                  OKIDATA • 82A • \$324.00</p>	<p><b>AN AFFORDABLE CAD SYSTEM FOR ENGINEERS &amp; DESIGNERS</b></p> <div style="text-align: center;"> <pre>                     graph TD                         Zenith[COMPUTER ZENITH ZF151-52 820K RAM] --- Autocad[SOFTWARE AUTOCAD]                         Zenith --- ZVM[ZENITH ZVM 185]                         Zenith --- Printer[PRINTER EPSON FX-80]                         Zenith --- Plotter[PLOTTER DMP-40]                         Zenith --- Digitizer[DIGITIZER DT-114]                     </pre> </div> <p>AutoCAD™ is a two-dimensional computer-aided drafting and design system suitable for many applications including drawings for architectural, mechanical, electrical, PCB layout, chemical, structural, and civil engineering. For the configuration as shown in the above flowchart,</p> <p style="text-align: center;"><b>\$5,800.00</b></p> <p>DT114 DIGITIZER 780, DT11—\$725                  DMP 40—\$795, DMP 41 or 42—\$2350                  DMP 51 and 52—\$3850 HP 7470A—\$940                  HP 7475—\$1650 Zenith 2VM 136                  PRINCETON GRAPHICS SR12, HI-RES COLOR—CALL</p> <p>CLEARANCE: EPSON QX10—\$1599</p> <p>Columbia, Eagle, NEC PC 8021, ZENITH, TELEVIDEO, COMPAQ, CORONA LASER PRINTERS (HI-RES)                  DESKTOPS: IBM PC/AT, ZENITH, APPLE, ETC .....CALL                  TERMINALS, PRINTERS, MODEMS, PLOTTERS, DIGITIZERS</p>
<p style="text-align: center;"><b>Cromemco</b> SYSTEMS AND COMPONENTS..CALL</p> <p style="text-align: center;"><b>COMPUTERS</b>                  Zenith, IBM, Sanyo, Apple, Cromemco, Dual, Dec</p> <p>Prices subject to change. American Express, Visa/Mastercard add 3%. F.O.B. point of shipment. 20% restocking fee for returned merchandise. Personal checks take 3 weeks to clear. COD on certified check only. N.Y. residents add sales tax. Manufacturers' warranty only. International customers, please confirm price before order. Accept P.O. from Fortune 500, schools and gov't.</p> <p>Computer Channel 226 Sherwood Ave. Farmingdale, NY 11735 For information CALL (516) 420-0142 To order CALL 1-800-331-3341</p>	<p style="text-align: center;"><b>NETWORKS—MULTIUSER SYSTEMS CAD CAE, CAM SYSTEMS</b></p> <p>3Com Ethernet network ..... CALL                  Filer server w/513 MB Winchester hard disk, 160 MB streamer tape backup, latest technology  <i>Bring the mainframe power to PC!</i></p>	<p style="text-align: center;"><b>SYSTEM CONFIGURATION</b></p> <p>We assemble systems at special prices, including software, special operating systems, shells etc. Call us for business systems, CAD systems, networking, LANS, graphics, mainframe links, interfacing, application integration.</p> <p>MULTI USER SOFTWARE USING MS-DOS  <b>FORTUNE 1500 COMPANIES—</b>  <b>LET US SOLVE YOUR SYSTEM NEEDS!</b></p>
<p><b>NEW</b> CASH REGISTER—COMPUTER COMBINATION SYSTEM—CALL!</p>		



is boring. The Modula-2 operating system is exciting, but it's taking forever to get the operating system (as opposed to the language) implemented on anything but Lilith (a machine designed especially to run Modula-2). Whether SI can win market share is open to question, but the market is wide open for something portable

that will support lots of languages. I reached the MSI booth just as they were announcing a very large (\$40 million or so) development deal with a Japanese software consortium; that surely ought to be enough to keep Knight and his former student John Little working until they get things perfected, and it shows that some big-

money people have confidence in them. Meanwhile, they're supposed to send me a copy, and Knight is working on a Modula-2 compiler to run under SI. I'm not holding my breath until MSI delivers, but I wish Knight well.

**THE NETWORK JUNGLE**

If you want computers to talk to each other, you could have problems because there are so many different networking systems. Corvus has Omninet. NCR bought the Corvus Omninet chip set, but of course its PC-to-PC net isn't compatible with Corvus Omninet. Corvus's network for Macintoshes won't talk to regular Omninet, although a planned higher-price adapter is coming Real Soon Now.

Meanwhile, CompuPro—oops, Viasyn—has opted for Datapoint's Arcnet. AT&T has a PC-to-PC-to-mini-to-mainframe network system developed largely by Locus of Santa Monica. Ethernet strides along, although the \$1000 per connection hobbles it a bit. IBM has a local-area network that isn't *really* a network at all, but promises two more nets—details not clear to me—within two years.

If there's anything like a hardware standard developing out there, I haven't seen it. The only networking system I have any familiarity with at all is Corvus's; that really *will* let you network Apples and IBM PCs, and in theory you could also network S-100 systems like CompuPro, except that Corvus has stopped making and supporting the S-100 network card.

Viasyn makes very good use of Arcnet; I've seen as many as five different kinds of CompuPro systems, with a total of 16 different computers, networked in a very smooth system for shifting files and programs back and forth.

The moral of the story is simple. Unless you're a guru (in which case you don't need my advice), don't get involved in networking until you have to. If you need to network some systems, try hard to stay with one kind

(continued)

Here are 70 reasons to buy at Elek-Tek, not to mention the fastest delivery anywhere.

**PRINTER ACCESSORIES**

- 1. **FR 192**  
Epson 80 col ribbon \$ 3.50
- 2. **FR 193**  
Epson 132 col ribbon 5.00
- 3. **FR 153A**  
OKI & Gemini Ribbon 2.50
- 4. **FF 7353**  
80 col printer stand (metal) 15.00
- 5. **FF 7354**  
132 col printer stand (metal) 18.00
- 6. **CB 5609**  
IBM PC to Epson cable, 8 ft 20.00

**Save 30% to 43%**  
off Manufacturer Suggested Ret. prices on  
**EPSON • Okidata • Gemini • NEC**  
**• TOSHIBA • COMREX • TTX**

- EPSON®**
- 7. RX 80/RX 80 FT CALL
  - 8. RX 100 \$ 350
  - 9. FX 80 + 390
  - 10. LX 80 CALL
  - 11. FX 100 575
  - 12. LQ 1500 par 1150
  - 13. Comrex II Comriter 360
- STAIR**
- 14. SG 10 CALL
  - 15. SD 10/15 CALL
  - 16. SR 10/15 CALL
- OKIDATA**
- 17. Ok: 84 CALL
  - 18. Ok: 92 CALL
  - 19. Ok: 93 CALL

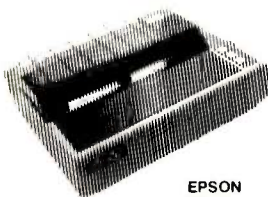

EPSON FX 80+

**OTHER PRINTERS**

- 20. TTX 1014 \$ 360
- 21. SCM D200 350
- 22. Toshiba P1351 1290
- 23. Toshiba P1340 730

**IBM PRODUCTS**

- 24. **Amdek 310A**  
Amber Monitor \$ 160
- Other Amdek Monitors .CALL
- 25. **Sakata Monitors** .CALL
- 26. **AST Six Pak 4**  
Multifunction Board 64K 250
- 27. **AST Megapius II**  
Multifunction Board 64K 270
- 28. **AST I/O Plus II**  
Multifunction Board 0K 125
- 29. **Quadram Quadboard**  
Multifunction Board 0K 210
- 30. **Quadram Quadboard**  
Multifunction Board 64K 270
- 31. **Quadcolor I**  
Graphic Board 210
- 32. **Paradise**  
Modular Graphics Card 290
- 33. **Hercules**  
Monochrome Card 329
- 34. **Hercules Color**  
Color Graphic Card 170
- 35. **Novation 4905911**  
Modem w/software 320
- 36. **Novation 4905921**  
Internal Modem w/software 320
- 37. **Hayes 1200B**  
Internal modem w/software 399
- 38. **Hayes 1200**  
External modem 459
- 39. **Anderson-Jacobson1212-2C01**  
Internal modem w/crosstalk 360
- 40. **Anderson-Jacobson1212-2C02**  
Modem w/crosstalk 2nd ser port 400
- 41. **TEAC FD55B**  
1/2 ht DSDD Disk Drive 129
- 42. **Switchcraft Keyboard**  
13 prog keys, heavy duty 175

**DISKETTES**

Call for Quantity pricing for 10 boxes or more.

- maxell.** Box of 10
- 43. **MF1** 3 1/2" SSDD \$ 34
  - 44. **MF2** 3 1/2" DSDD 50
  - 45. **MD1** 5 1/4" SSDD 16.50
  - 46. **MD2** 5 1/4" DSDD 21.50
  - 47. **MD2DD** 5 1/4" DSDD/96 TPI 35
  - 48. **MD2HD** 5 1/4" DSDD/IBM AT 45
  - 49. **FD1** 8" SSDD 32
  - 50. **FD2** 8" DSDD 37
- 3M**
- 51. **3M3SS** 3 1/2" SSDD 34
  - 52. **3M3DS** 3 1/2" DSDD CALL
  - 53. **3M5SSDD** 5 1/4" SSDD 16.50
  - 54. **3M5DSDD** 5 1/4" DSDD 21.50
  - 55. **3M5DSD96** 5 1/4" DSDD/96 TPI 31
- Dysan**
- 56. **3M8SSDD** 8" SSDD 21
  - 57. **3M8DSDD** 8" DSDD 29
  - 58. **Dys 12** 5 1/4" SSDD 19
  - 59. **Dys 22** 5 1/4" DSDD 25
  - 60. **Dys 33** 5 1/4" DSDD/96 TPI 45
  - 61. **Dys 24** 5 1/4" DSDD/IBM AT 50
  - 62. **Dys 8128** 8" SSDD 27
  - 63. **Dys 8228** 8" DSDD 32
- wabash**
- 64. **WAB 1111** 5 1/4" SSDD 11
  - 65. **WAB 1212** 5 1/4" SSDD 12
  - 66. **WAB 2222** 5 1/4" DSDD 13

**DISKETTE ACCESSORIES**

- 67. **RS1 600** 5 1/4" Head Cleaning Kit (30 Cleanings) \$ 6
- 68. **F 320** 3 1/2" Head Cleaning Kit (20 cleanings) 25
- 69. **MM 5** Media Mate-Holds 50 5 1/4" disks 10
- 70. **MM 3** Media Mate-Holds 30 3 1/2" 9

CALL TOLL FREE 800-621-1269 EXCEPT Illinois, Alaska, Hawaii Inquiry 139

Corp. Accts. Invited. Min. Ord. \$15.00. Visa or MasterCard by Mail or Phone. Mail Cashier's Check, Mon. Ord., Personal Check (2 wks. to clear) Add \$4.00 1st Item. (AK, HI, P.R., Canada add \$10.00 1st item) \$1.00 ea. add'l shipg. & handl. Shipments to IL address add 7% tax. Prices subj. to change. WRITE for free catalog. RETURN POLICY: Defective Only. Most products replaced within 30 days of purchase with identical merchandise only. Computer and large peripherals replaced only when defective on arrival (within 3 work days of delivery). Other problems covered by mfr. warranty. ALL ELEK-TEK MERCHANDISE IS BRAND NEW, FIRST QUALITY AND COMPLETE. Delivery subject to availability.

**ELEK-TEK, inc.**

6557 N. Lincoln Ave., Chicago, IL 60645  
(312) 631-7800 (312) 677-7660

# The C Compiler Thousands Rely On

# C-86™

NEW-IMPROVED Version 2.2 Compiles 25% Faster  
IBM-PC AT Support

When the going gets tough, Optimizing C86 comes through time and time again. C86 is a highly dependable C compiler that has been optimized through the years to provide the best combination of reliability, speed, and performance.

#### FAST, IN-LINE 8087/80287 SUPPORT

Now you can take full advantage of 8087/80287 capabilities, allowing your programs to run many times faster than possible with other C compilers. Plus the source code to all routines is included, so you have complete control over all functions.

#### MORE OF THE FEATURES YOU WANT

- **SOURCE** is provided to all libraries for total programming control. The source includes a set of standard UNIX routines plus many DOS specific functions.
- **SPECIAL IBM-PC LIBRARY** including communication, screen, and keyboard handling functions.

- **COMPATIBLE WITH WIDELY AVAILABLE LIBRARIES** such as HALO screen graphics and many, many others (call for list).
- **TOPVIEW SUPPORT LIBRARY** provides windowing capabilities.
- **SPEED OPTIMIZATION** — there's always room to tighten your code, and Computer Innovations has the tools to help. For example, *PROFILER-86* helps identify key areas for optimization.

#### TECHNICAL SUPPORT, NOBODY DOES IT BETTER

Computer Innovations has earned a reputation for providing customer support that is **unequaled** in the industry. This includes a user's group, an on-line bulletin board, and a user's newsletter.

#### JOIN THE THOUSANDS OF PROGRAMMERS WHO TRUST AND RELY ON C86

For Further Information Call 800-922-0169.  
Technical Assistance Call (201) 542-5920.  
Computer Innovations features a full line of C products including **C-to-dBase** (dBase development tool) and **Introducing C** (C Interpreter Language Learning System). Call or write for a product profile.

 **COMPUTER  
INNOVATIONS, INC.**  
980 Shrewsbury Avenue, Tinton Falls, NJ 07724

For Further Information Call  
**800-922-0169**  
Technical Assistance Call (201) 542-5920



of net and one brand of computer; if you have to connect a number of different kinds of machines, gulp hard and hire an expert.

**THE GREAT SOFTWARE PURGE**

They haven't begun tearing off the top of my house, but they'll start when the rain stops. That means the attic must be emptied. Which means grief. I've lived here in Chaos Manor for 20 years, and it's a *big* house. Whenever we accumulated too much junk, I would go up and floor another section of the attic, briefly creating lots and lots of room; but eventually that would fill and I'd have it to do again.

Last time there was nothing left to floor. We have managed to fill 2500 square feet to a depth of three to four feet with every conceivable kind of stuff from wedding pictures to old textbooks to unpublished manuscripts to research notes on articles

and books I wrote a dozen years ago. To make it worse, the downstairs is now filled with more stuff that would have been put in the attic if there were any room for it.

It all has to go somewhere else.

Fortunately, I have a small pickup truck, and it doesn't cost that much to rent a large (20 by 30) public storage locker; a couple of frantic weekends filled the local school's paper drive bins and half-filled the locker; and then came the moment of truth.

Software flows in here like a river. Understand, I'm not complaining. I'd have nothing to write about without it, and I'm still excited when I open a package with something new and neat and different in it. Moreover, I feel some obligation to the people who sent it, particularly to the small outfits that can't afford advertising. When software first comes in, I try to figure

out if it does anything interesting. More on that in a moment; but the bottom line is that if it doesn't look particularly interesting it goes into a holding file that tends to work like a first-in/last-out queue. It's supposed to be first-in/first-out, and it is as long as there's shelf space available; but eventually the shelves fill, the piles start, and we never reach the bottom of the pile.

Clearly, what's needed is more software shelf space—so I made some. Ruthlessly. I went through the Great Software Dumps: shelves, piles, everywhere. If it's dated prior to the spring of 1984 and I don't use it, it went. That wasn't universally true. I found a few things that looked sufficiently interesting to warrant keeping; but the rest went. The disks were stripped out and thrown into a box with a large magnet, and the documents were

*(continued)*

# TESS

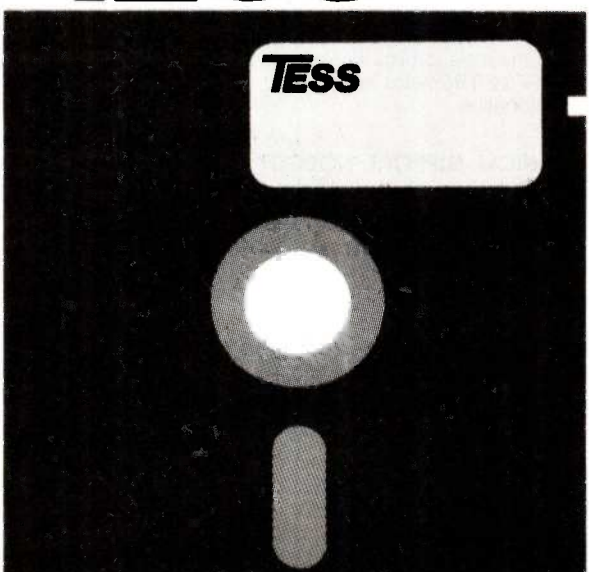

\$19500

Corporate discounts available. Price includes 12 month updating service.

## TERMINAL EMULATION SOFTWARE SYSTEM

# VT100-4010

- **FREE SOFTWARE UPDATES**
- Double height / double width, VT102 support
- ANSI / ISO color command support
- Convenient help screens
- ASCII file transfers
- IBM / EPSON graphics printer support
- HERCULES, HAYES and KEYTRONICS support
- Monitor mode for data stream debugging
- "Smart" key assignments
- Extensive setup support

Enhance through-put of your IBM PC, XT, AT or portable by using TESS®...the first Terminal Emulation Software System developed and optimized by a leading graphics terminal house. Unparalleled user productivity...2 to 10 times faster than other emulators...data buffering from host while doing local processing...and much more.

**ORDER TESS® NOW...CALL 1-800-633-2252, Ext. 680**  
Satisfaction guaranteed or return within 30 days for full refund. Visa, Mastercard or C.O.D. accepted and we pay shipping.

Trademarks: VT100 is a trademark of Digital Equipment Corp.  
4010 is a trademark of Tektronix Corp.

## ID SYSTEMS

CORPORATION  
6175-W Shamrock Court • Dublin, Ohio 43017

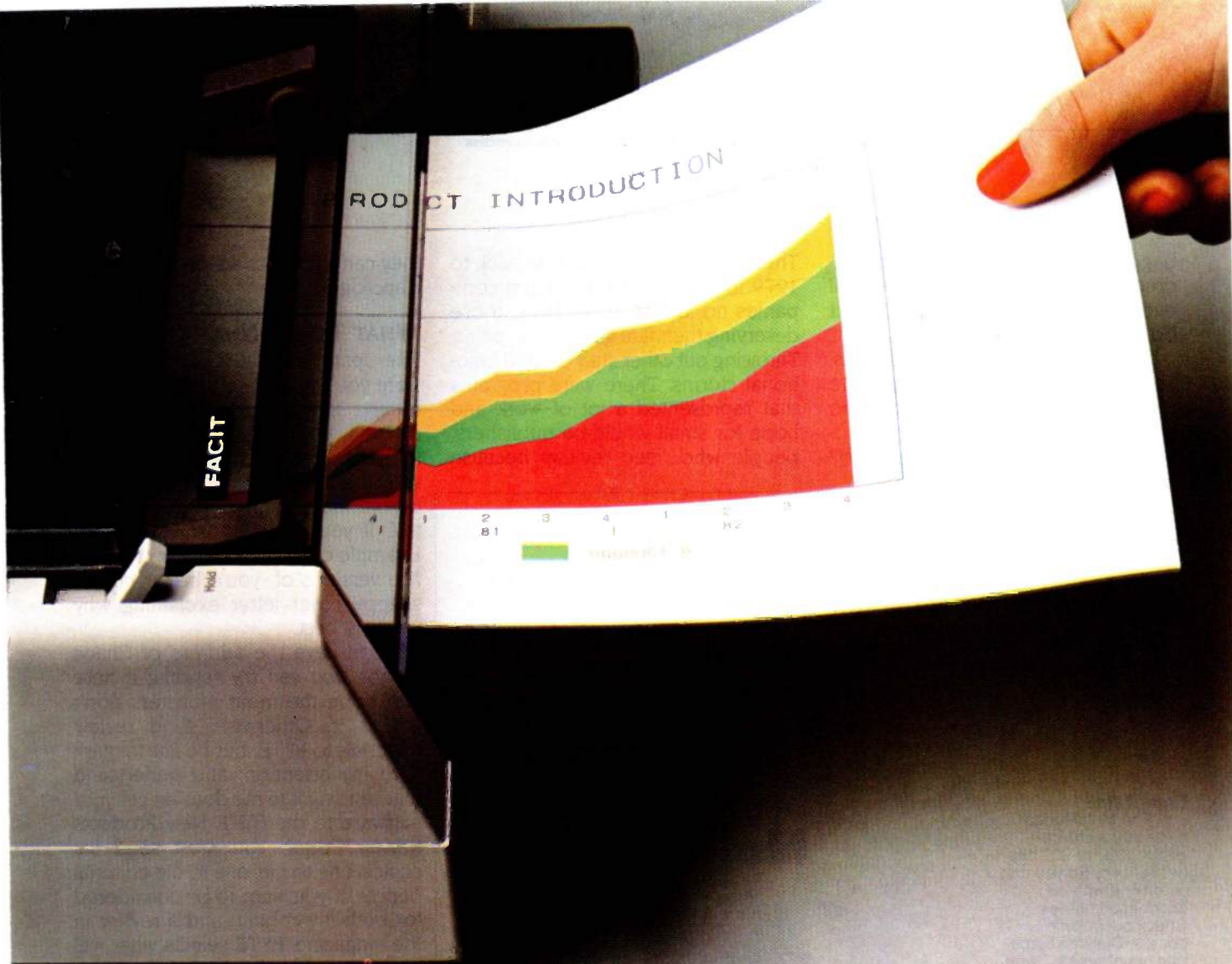

# GET THE PICTURE WITH FACIT 6-PEN PLOTTERS

Multicolour graphics on paper and overhead transparency film are now a reality at a price every computer owner can afford – with the new Facit 4550 and Facit 4551 Pen Plotters.

The 6-pen cassette design provides instant colour changes with a multitude of colour set-ups. Longlife ballpoint for paper, oil-based fiber-tip for transparencies and water-based ceramic pens for high-quality CAD drawings are available with 8 to 12 different colours. Two pen-cassettes can be stored in pockets on top of the casing. The pens are securely sealed to prevent drying.

Business graphics, CAD, CAE, science and engineering plottings are handled with a character resolution as high as 10×10 elements per character. Facit 4550 accepts media sizes ISO A4 or 8 1/2 × 11", while Facit 4551 takes media up to ISO A3 or 11×17".

## FRIENDS WITH ALL MAJOR COMPUTERS

With HP-Graphic Language emulation and serial/parallel interfaces, the plotters easily make friends with all major computer models on the market. Software packages include Lotus 1–2–3,

Symphony, Fast Graphs, DR Draw/Graph, BPS, etc.

Got the picture? Get it at your nearest Facit representative!

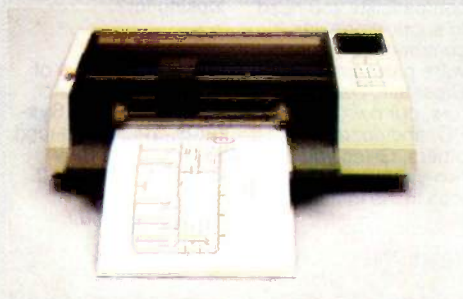

# FACIT

Inquiry 51



bagged for the paper drive. The hundreds of disks that are involved will eventually be bulk-erased and donated to a school.

Understand, I didn't *like* doing this. Some of the stuff was nothing more than early versions and presented no problems—how many copies of WordStar 1.6 do you really need, anyway?

There were programs dating back to 1979 in there. Some was from companies no longer in business; those deserving their fate gave me no pains. Throwing out other stuff created emotional storms. There were programs that represented a lot of work and hope for small would-be publishers; people who need reviews because

they can't afford to advertise. To them I apologize.

**WHAT TO DO NOW**

The upshot is that if you have software you want me to look at and you haven't sent anything since, say, July of 1984, you'd do well to send your latest copies. Whether I do anything with it will depend on a number of factors, many of them out of your control: if your program is Yet Another Example of a program I just received five versions of, you'd better have a snappy cover letter explaining why yours is best.

If you have the address of Chaos Manor, you can try sending it here and hope the moat monsters don't get at it. Otherwise, send review materials to BYTE, but be *sure* to mark it to my attention; and understand that sending it to me does *not* get your software to the BYTE New Products Review Editor. You must send *two* copies, one to me, one to the editorial people, if you want to be considered for both my column and a review in the magazine. BYTE selects what will be reviewed in the rest of the book by rules unknown to me; one thing is certain, they don't consult me about what they choose. Once in a while the editors in Peterborough will direct my attention to something interesting that I haven't seen, but otherwise I don't consult them either.

BYTE returns unreviewed software. I'd go broke doing that, so I don't. If I like a program and it does something I need done, I'll use it until something better comes along. If I like it but don't have any need for that capability, I'll sometimes ask the publisher if I can send it along to someone who does have a need for it. Otherwise, it goes into The System, sometimes to emerge when I'm stuck for something to write about, sometimes to molder until the next Great Purge.

**SO LONG HAS IT BEEN?**

Before I get to what I think is interesting software, I need to attack a complaint.

(continued)

**What do you get when you cross 1200 baud, free on-line time, and extra features at a price Hayes can't match?**

**Data Rate?**

The MultiModem gives you a choice—either 1200 or 300 bits per second. So you can go on-line with the information utilities. Check out bulletin boards. Dial into corporate mainframes. Swap files with friends.

**On-Line Time?**

With the MultiModem you get CompuServe's DemoPak, a free two-hour demonstration of their service, and up to seven more free hours if you subscribe. You also get a \$50 credit towards NewsNet's business newsletter service.

**Features & Price?**

Of course, the MultiModem gives you automatic dial, answer, and disconnect. Gives you the Hayes-compatibility you need to support popular communications software programs like Crosstalk, Data Capture, our own MultiCom PC, and dozens of others. Gives you a two-year warranty, tops in the industry.

**But Better?**

Yes. The MultiModem gives you features the Hayes Smartmodem 1200™ can't match. Features like dial-tone and busy-signal detection for more accurate dialing and redialing. Like a battery-backed memory for six phone numbers. All at a retail price of just \$549—compared to \$699 for the Smartmodem.

What do you get? The new MultiModem, from Multi-Tech Systems. Isn't this the answer you've been looking for?

For the name of your local distributor, write **Multi-Tech Systems, Inc.**, 82 Second Avenue S.E., New Brighton, MN 55112. Or call us at (612) 631-3550.

**MultiModem.**



**MultiTech**  
Systems

The right answer every time.

Inquiry 274

Trademarks—MultiModem, MultiCom PC, Multi-Tech Systems, Inc.—CompuServe, CompuServe Information Services, an H & R Block company—NewsNet, NewsNet, Inc.—Crosstalk, Microsoft, Inc.—Data Capture, Southeastern Software—Smartmodem, Hayes Microcomputer Products, Inc.

Inquiry 27 —>

# INTRODUCING ANTHROCART.™

## WORKSPACE FOR THE HUMAN RACE.

AnthroCart is a serious workstation. Designed specifically with your uses in mind, the AnthroCart takes up little space, yet expands to grow right along with you and your system. Adjustable shelves, swing-out baskets and other modular components give you the flexibility you need.

AnthroCart is also a real beast of burden, tough enough to support up to 150 lbs., yet mobile enough to roll next door or down the street. And its durable steel-base construction stands up to both human and machine (so much so, we offer a five-year, unconditional guarantee!).

To order your AnthroCart, or to get more information, call toll free:

**1-800-547-4000, Dept. 501**

In Oregon, call (503) 684-3000, Dept. 501.

VAR and dealer inquiries welcome.



AnthroCart shown with printer basket option.

Basic AnthroCart list price \$495.

Also available in Oak Finish.



**ANTHRO**

A subsidiary of  
TEKTRONIX, INC.

Anthro Corporation  
3221 NW Yeon Street  
Portland, OR 97210  
TWX (910) 333-6481

AnthroCart is a trademark and Anthro is a registered trademark of Anthro Corporation, a subsidiary of TEKTRONIX, INC.



I have several—well, no more than four—recent letters taking me to task for concentrating on big, expensive machines to the neglect of smaller and more affordable ones. "You're too snooty to write about Kaypro, which must be beneath your notice," one letter says. Another reader believes I ignore CP/M systems, "which are really the machines for 'the rest of us' who can't afford the Macintosh." I haven't, he says, reviewed a new CP/M program for years.

My first reaction was a smile, but then I looked back through recent columns, and by gollies I have tended to write mostly about Mac, and my CompuPro (oops, Viasyn) 8/16, and the Sage (oops, Stride Micro) 68000 systems. Not exclusively, but I suppose a CP/M enthusiast could accuse me of neglecting 8080 and Z80 stuff. That's ironic; it was only a few years ago that *InfoWorld* and other computer magazines were quoting me as having "pronounced CP/M the standard

for the micro industry"; while nearly all the people associated with Kaypro credit me as having given a big sales boost to their "Chevrolet" (I compared the Osborne to the VW, Kaypro to the Chevrolet, and Otrona Attache to the BMW); while I am to this day one of the very few columnists in non-Atari magazines to review Vincent Cate's little Atari Connection that lets you run CP/M on an Atari 800; and I regularly recommend an Atari 800 (or 800-compatible machine), Rana disk drives, and Wico joystick as a good youngster's system they won't grow out of too fast.

It's true that I don't much care for the Commodore machines (even though there are, I guess, more of them than anything else except the doorstep Sinclair); but that's because I do a lot of writing, and I don't much care for *any* system that uses a television screen or otherwise displays fuzzy and shaky letters.

CP/M systems are a different matter.

A good Z80 CP/M system can do an awful lot; indeed, I'm writing *this* on a Z80. My accounting system (which I wrote in Compiling CBASIC); The Word Plus, still the best spelling checker on the market bar none; WRITE, the word-processing program I use to create nearly everything I do from books to these columns to my business and personal correspondence; the logbook program, and the index program I use to organize my log; Calendar/I, which organizes my schedule; every one of these programs runs on an 8-bit CP/M machine.

There are many bargains in good CP/M machines, and the Kaypro, with its bundled software, is certainly one of them. Three writing partners: John F. Carr, Dean Ing, and Roland Green have recently started using Kaypro systems, and a fourth, David Gerrold, now writes a column for the Kaypro magazine *Profiles*. They're all quite happy. Norman Spinrad loves his Kaypro 10.

I've never had a Morrow, but I hear good things about it. Barry Workman is very fond of his Lobo. The Epson QX-10 remains overpriced, but it is probably the cheapest machine you can sit down and begin using with little to no instruction, and if you add SemiDisk's RAM-disk board to the QX-10 it takes a lot of the sting out of its slow disk operations. I still use the wonderful little Otrona Attache on trips, but, alas, the Otrona company seems to have made some serious mistakes. If they'd worked as hard to promote the Attache as the BMW of 8-bit systems and continued to add bundled software to their already impressive package of programs, they might well have made themselves a profitable niche.

When all is said and done, though, there *isn't* very much exciting new software being written for Z80 machines. The reason is easy enough to see. The Z80 has the inherent limitation that it cannot directly address more than 64K bytes of memory. You can come up with ways to get at more memory, but, alas, there never developed a *standard* way to do that; the result is that nearly everyone tried a different

## ITEMS DISCUSSED

**CALENDAR/I** ..... \$150  
Clear Systems  
607 Ashland Ave., Suite A  
Santa Monica, CA 90401  
(213) 394-7740

**CP/M UTILITIES** ..... \$32.50  
**WRITE** ..... \$239  
Workman and Associates  
112 Marion Ave.  
Pasadena, CA 91106  
(818) 796-4401

**DBASE III** ..... \$695  
**FRAMEWORK** ..... \$695  
Ashton-Tate  
10150 West Jefferson Blvd.  
Culver City, CA 90230  
(213) 204-5570

**PROLOK** ..... \$8.49  
Vault Corp.  
2649 Townsgate Rd., Suite 500  
Westlake Village, CA 91361  
(800) 445-0193  
(800) 821-8638 (California)

**SI OPERATING SYSTEM** .. \$250-\$950  
Multi Solutions Inc. one-time fee  
660 Whitehead Rd.  
Lawrenceville, NJ 08648  
(609) 695-1337

**SYMPHONY** ..... \$695  
Lotus Development Corp.  
161 First St.  
Cambridge, MA 02142  
(617) 492-7171

**SYSTEM BACKUP** ..... \$49.95  
Norell Data Systems  
POB 70127  
Los Angeles, CA 90010  
(213) 257-2026

**THE WORD PLUS** ..... \$150  
Oasis Systems Inc.  
7907 Ostrow St., Suite F  
San Diego, CA 92111  
(619) 279-5711

method, big-memory software developed for one kind of hardware wouldn't run on anything else, debugging was costly. The market base isn't large enough, not compared to the IBM PC or the Apple II (although many Apple IIs do a *splendid* job of running CP/M programs; it only requires the right hardware addition, something like an Applicard or the Digital Research Gold Card).

There's still some solid progress being made. Every now and then, really good CP/M programs appear. Some, like WRITE, are really excellent—but they're seldom marketed by big concerns willing to spend lots of money on promotion. Many CP/M programs hang around for a couple of years, some never to be seen again, others to reappear in the public domain.

CP/M systems are adequate for many purposes and will be for years; but, alas, the micro industry is moving toward new standards of adequacy that will, eventually, relegate 8-bit CP/M computers to low-cost entry-level systems—or relics, like my neighbor's 1957 Studebaker.

### SO WHAT IS INTERESTING SOFTWARE?

Just at the moment I'm in a dilemma.

I have yet to see any computer system whatever that I would rather sit in front of for days on end than Zeke II, my CompuPro letter-series Z80. The reason is simple. Zeke II doesn't have a terminal. Instead, he has a memory-mapped video board, one of

the very last of the boards from the days of Lee Felsenstein and the Sol computer. His video output goes onto a 15-inch white-on-black Hitachi high-resolution monitor that sits about 30 inches from my schnoz. The letters are big enough to read from across the room.

The keyboard is an ancient Archive keyboard. Archive has so thoroughly vanished that I can't find even a forwarding address—but Larry Niven and I have about four spare copies of their Hall-effect keyboards (no switch contacts; the keys may last forever), and except for the new Wico Smartline keyboard with its wonderful trackball, I haven't seen any keyboard anywhere that I'd even consider trading the Archive for.

The text editor is WRITE, which works only under 8-bit CP/M. Again, I have nearly every text editor known to humanity, and I have never found one better for just wailing away when you want to create lots of text—which is, after all, what I do for a living. There are lots of better *programming* editors, including WordStar (sort of everyone's second-choice editor, isn't it?), WordMaster (nearly neglected by MicroPro), Superwriter, and the EMACS-like editors sold by Mark of the Unicorn; but for just turning out 10,000 words of text in a couple of days, I've never *heard* of anything better than WRITE.

All my printing, spelling checking, communications with BYTE (hurrah! the BYTENet for authors seems reli-

*There's solid progress  
being made: every  
now and then  
really good CP/M  
programs appear.*

able lately; we've had some problems with the local New Hampshire phone system), accounting, check writing, and such like are done on larger systems, particularly the new (not yet named) Viasyn 8/16.

WRITE will, of course, work on a System 8/16, and if need be I can probably hack up a BIOS that lets the Viasyn 8/16 or its companion Shirley (CompuPro 10, now I suppose the Viasyn 10) communicate through the VDM (video-display module) memory-map video board and the Archive keyboard. It wouldn't be easy. Maybe I can talk someone else into doing it. Failing that, I can keep Zeke II and use the new Viasyn networking system to connect up. Either way, I'll get to keep WRITE and my big screen.

Alas, that's no longer quite good enough.

It isn't that there's a better program for text creation than WRITE. It's that WRITE doesn't do a lot of the fancier things that technical books demand. The spelling checker is external; not

*(continued)*

## "BOOT STRAP" YOUR WAY INTO EXPERT SYSTEMS



An interactive PROLOG system specially developed for use on micro computers. This powerful implementation is available for 16 bit 8088/86 micros using CP/M 86 or MS DOS/PC DOS such as the IBM PC or IBM compatibles and 8 bit Z80 micros using CP/M 80.

From US \$195.00.



A version of PROLOG specially developed for use on the larger memory 68000 machines as well as mini computers under the Unix operating system. Sharing many of the features found on LPA micro-PROLOG, this upward compatible language makes full use of the power of Unix.

From US \$695.00



**apes** — Augmented PROLOG for Expert Systems — is an Expert System shell developed by Logic Based Systems Ltd., in close association with Imperial College and Logic Programming Associates Ltd., to complement LPA micro-PROLOG and LPA sigma-PROLOG. It greatly facilitates the development of Expert Systems.

**apes** from US \$395.00

For information contact:—  
NORTH AMERICA

**PS** Programming Logic Systems Inc.,  
31 Crescent Drive, Milford, CT 06460, U.S.A.  
Tel: (203) 877 7988

REST OF THE WORLD

Logic Programming Associates Ltd., Dept. BY/1  
10 Burntwood Close, London SW18 3JU  
Tel: 01-874 0350

**With Products from Logic Programming Assocs.**



# WALTZ LISP

The universal, super-efficient  
Lisp for PC-DOS, MS-DOS,  
CP/M-86 and CP/M-80  
systems.

Waltz Lisp is a very powerful and complete implementation of Lisp. It is similar to *Franz* (the Lisp running under *Unix*), and is substantially compatible with *MacLisp* and other mainframe Lisps.

**Ultra fast.** In independent tests, **Waltz Lisp** was up to twenty(!) times faster than competing microcomputer Lisps.

**Easy to use.** The interpreter can directly load program files created with any ASCII text editor. Full debugging and error handling facilities are available at all times. No debuggers to link or load.

**Practical.** Random file access, binary file support, and extensive string operations make **Waltz Lisp** suitable for general programming. A text-file difference program and other utilities are included in the package.

**Full Lisp.** Functions of type *lambda (expr), nlambda (fexpr), lexpr, macro*. Splicing and non-splicing character macros. Full suite of mappers, iterators, etc. Long integers (up to 611 digits). Fast list sorting using user defined comparison predicates. Built-in prettyprinting and formatting facilities. Over 250 functions in all.

**Flexible.** Transparent (yet programmable) handling of undefined function references allows large programs to reside partially on disk at run time. Optional automatic loading of initialization file. User control over all aspects of the system. Assembly language interface.

**Superbly documented.** Each aspect of the interpreter is described in detail. The 300+ page manual includes an exhaustive index and hundreds of illustrative examples.

Order **Waltz Lisp** now and receive **free** our  
**PROLOG** Interpreter

**Clog Prolog** is a tiny (but very complete) Prolog implementation written entirely in **Waltz Lisp**. In addition to the full source code, the package includes a 50 page **Clog** manual.

16-bit versions require DOS 2.x or CP/M-86 and 90K RAM (more recommended). Z-80 version requires CP/M 2.x or 3.x and 48K RAM minimum. **Waltz Lisp** runs on hundreds of different computer models and is available in all disk formats.



**\$169\***

\*Manual only: \$30 (refundable with order). Foreign orders: add \$5 for surface mail, \$20 for airmail. COD add \$3. Apple CP/M, hard sector, and 3" formats add \$15. MC/Visa accepted.

For further information or to order call

**1-800-LIP-4000 DEPT. 20**

In Oregon and outside USA call 1-503-684-3000

**PC** 15930 SW Colony Pl.,  
Portland, OR 97224

**PRO** CODE  
INTERNATIONAL

## CHAOS MANOR

### I don't really care to be tied to the future of UNIX.

a fatal flaw, because Word Plus is fast, but minorly inconvenient. There's no good bibliography or footnote capability. The index capability that Peter has worked out is all right, but it is pretty slow and hard for me to use. There's no on-board sort facility, no calculation, no spreadsheet. No graphics and no graphs. No explicit outline (idea processor) system, although WRITE does have features that, coupled with 500K bytes of RAM disk, work about as well. WRITE is great for letters and manuscripts; it will do a fair job on documents, but not a superb one.

Worse, there's nothing like Sidekick on Zeke II, and I have just *got* to have that program before my little green telephone index completely disintegrates. Sidekick lets me keep notes on line, calculate, look up phone numbers—not all the word-mashing things I want to do, but some of them.

Meanwhile, Tony Pietsch's Viasyn S-100 PCompatible video board, which lets you fool the System 8/16 into thinking it's a 98 percent compatible PC clone (and has a jack on the back into which you can plug the Wico Smartline keyboard) is now in engineering test; I'll probably have one about the time you read this. I'll also have, probably, an extremely fast 80286 processor running the system and Z80 slave (SPUZ) boards.

I've no trouble translating WRITE files into WordStar (or any other kind) of files; thus I can, for as long as I want, continue to use WRITE to create text, pass it to some other text editor, and do extensive word processing there. I'll hang on for a while. But I am looking for some generic solutions; something I can begin to learn in the expectation that my time won't be

wasted. That may be one big integrated program—but I doubt it. More likely, it's going to be a whole set of small utilities.

UNIX, of course, has a whole set of such utilities built into the operating system. The UNIX editor is lousy, but how long will it take a good programmer to do the functional equivalent of WRITE in C? A long time, if it's done as cleverly as Tony Pietsch did it in 8080 assembler; he kept the code amazingly compact. However, the 8088 and upwards family of chips can directly address plenty of memory; there's no *need* to keep the code so small.

I don't really care to be tied to the future of UNIX.

We'll see. Anyway, that's some of what I find interesting just now. I suppose it will change one day. . .

### WINDING DOWN

I'm fading fast. Roberta tells me she has the bug, and worse, so does the housekeeper. It promises to be an interesting week.

The books of the month have nothing to do with computers. I read *The Roman Empire* by Colin Wells (Stanford University Press). He disputes several of Gibbons's conclusions. Second, *The Great Siege, Malta 1565* by Ernie Bradford (Penguin). Finally, *Skywalking, The Life and Films of GEORGE LUCAS* by Dave Pollock. If you like the subjects, those are good books. Otherwise, forget it.

I've recently received three examples of the new Osborne Paperback Software Library, all for the PC and "close compatibles"; alas, no time even to open them. I was somewhat impressed with the packaging.

Now to collapse. ■

Jerry Pournelle welcomes readers' comments and opinions. Send a self-addressed, stamped envelope to Jerry Pournelle, c/o BYTE Publications, POB 372, Hancock, NH 03449. Please put your address on the letter as well as on the envelope. Due to the high volume of letters, Jerry cannot guarantee a personal reply.

I get a lot of letters, for which I thank you all. Please don't stop writing. However: I can't answer all the letters I receive, either in the column or individually. I can't even answer all the *interesting* letters. Moreover, even if I select a letter for a reply, there may not be room in BYTE. I have tried in past times to send a copy of the proposed reply to everyone whose letter I selected, whether or not a self-addressed, stamped envelope was enclosed.

I can't do that any longer. If you can't send postage, then you can't; but addressing envelopes is eating up too much time. Please?

## BORLAND COMPLAINTS

Dear Jerry,

I am writing because, although I believe that the phenomenon represented by Turbo Pascal and Borland is all to the good, I don't think the euphoria spread by you, among others, is altogether justified. My complaints follow:

The installation program for Turbo Pascal is enough to drive people like myself with a graphics card and green screen blind. The program tries to write in color and succeeds only in being illegible. There appears to be no way to turn this off. The installation program is a nuisance to use anyway. If you want to change the twenty-third item, you have to go through the previous 22. The defaults on Borland's editor make you use WordStar-type controls and I detest WordStar, so the installation was a fairly lengthy and unpleasant procedure.

The spreadsheet supplied as a sample program is useless. There appears to be no way to change a cell into a formula cell, which is the whole point of a spreadsheet. There is certainly no way documented, and after reading the code for a half hour, I still could see no way. I suppose it is churlish to complain about a free program, but anyway it is worth no more than I paid for it.

Nowhere is it mentioned in the ads that Sidekick is supplied on a double-sided copy-protected disk. So my copy of it is

useless to me. I can't use it, and I can't even take it to my office and copy it onto single-sided disks.

Why does Borland International add a \$15 charge for foreign orders? And why won't they accept credit-card orders from them? Other software houses accept credit-card orders on foreign orders and either add a small charge for the extra postage or don't even bother to do that. For example, Laboratory Microsystems treats foreign customers exactly the same as domestic. I actually purchased my Borland programs from Micro-Way Inc., which added a small postage charge.

You have often written about absurd software licenses. There is none worse than Borland's, which claims it is "illegal" to use their software without returning the license agreement. I have no intention of returning it under that kind of threat. On the other hand, I do feel bound not to give copies away.

MICHAEL BARR  
Montreal, Quebec, Canada

*Well, the "license agreement" is a bit silly; I've commented before about the absurdity of trying to cover your flanks with both license and copyright, since the rights conflict. Oh, well.*

*I've had other outlanders complain about the extra \$15; Philippe Kahn of Borland tells me that it costs him that much to fill out all the paperwork in order to export this high-tech item; and he can't afford to pay that himself. I doubt that makes you feel better, but I have no remedy.*

*I still think Turbo Pascal is one of the best bargains in the business.—Jerry*

## MAYBE IT WAS DRACULA

Dear Jerry,

Your comments about the origin of bug and *le cafard* in the October BYTE (page 330) were very interesting.

I've often heard the story about the dead moth in the relay. It could have happened! But I've also wondered why faulty computers couldn't be "debatted."

In late 1962 or early 1963 the IBM 7010 computer was undergoing engineering tests before being released to production.

It was being run 24 hours a day, seven days a week, in an attempt to make it fail (it did, numerous times, and fixes were incorporated in the design). Although I was one of the engineers on the design team, fortunately I didn't draw late-shift test duty. Therefore, I was among those who chuckled one morning when we read in the logbook that the guys on the graveyard shift had spent some time dodging a bat flitting around the machine room. We figured they hadn't been getting enough sleep.

Their reputations were restored several weeks later when the machine was being dismantled for shipment to the manufacturing plant or someplace. Inside the power supply, where it had apparently been electrocuted, was the rapidly decomposing corpse of a bat.

WALLACE B. RILEY  
San Francisco, CA

*I have heard Grace Hopper tell the story of the first bug—they actually Scotch-taped the moth into the logbook—but I have never heard of bats in the computer before!*

*When I was an undergraduate, a small bat flew into my room and made a home inside an old Zenith mahogany high-arch vacuum-tube radio my landlady furnished with the room. He—I think he, although with bats it's hard to tell—lived there all winter, eating mostly milk and table scraps and sometimes flying out the window, presumably to hunt insects. Come spring he left me.*

*If my bat would live in a radio, I suppose another might find a computer quite cozy . . . —Jerry*

## MAC AND LISA

Dear Jerry,

I just have to add my two cents to the MacDebate. As a computer user who is a systems engineer, a systems programmer, and a student of psychology (in particular ergonomics), I feel well qualified to comment on the subject of user-friendliness. However, the problem with the Mac (and with Lisa for that matter) is mostly one of nomenclature.

(continued)



## CHAOS MANOR MAIL

It would be stretching the common definition of computer to call a Wang word processor or an arcade video game a computer, but they sure do need to compute to do their jobs. So it is with Mac and Lisa: they compute, but they are not computers. Perhaps we should call them productivity-enhancement tools.

As a programmer and engineer, I expect a lot of my machines. I expect them to do exactly what I want in exactly the way I want them to. Give me a twelfth-generation computer that reads my mind and formats output to my liking and I'll be happy. Until then, I'll probably program my own applications when I have the time. That is the main reason I don't like Mac and Lisa. They are not programmable devices. They don't seem to be designed for that.

If one accepts that these instances of the class electronica are not computers, then many of the complaints about them become moot. After all, I don't often worry that my secretary's word processor doesn't run BASIC or that my phone-answering machine doesn't understand the CP/M operating system. There is still

the issue of friendliness, however.

My hands-on use of these machines has been limited to a demo, but it is enough to convince me that Apple will *never* make a decent keyboard. I can hear them now, "But with the mouse. . . ." Unfortunately, my experience with Apple mice has convinced me that I can generalize my last comment to include all physical input devices. A touch-typist keeps track of eight fingers and two thumbs on 50 keys on a typewriter, more on a terminal or other keyboard device. Does Apple really think that two buttons and two fingers would be confusing? It would also be nice if the mouse had enough mass to let you know it was there; it's just too cheap for my taste.

That's all I have to say that I haven't seen in print already. Two things in parting. First, you might be interested to know that this is being composed on my HP 110 using Memomaker and will be printed at my office in the morning using an IBM PC XT as a print spooler; I love this machine! Second, I came in during the second act; could you print a Cast of Characters on occasion (e.g., the part of Zorro is played

by a Z-100, etc.)? Thanks and keep up the good work; I always enjoy your column.

CHRISTOPHER NELSON  
Croton-on-Hudson, NY

## UNIX AND S-100

Dear Jerry,

It may seem to you that there is a future for the computer hobbyist, but I fear I'm destined to join the dinosaurs even before I get my machine built. Because I'm not rich, and actually *enjoy* configuring a system on a board-by-board basis, that's the way I'm buying it. My interests lean toward artificial intelligence, and I want a machine with some horsepower on which I can run UNIX. (Yes, I know, UNIX is easy for newcomers to get lost in; I'll be naming my machine Twilight Zone.) Now's the dilemma: CompuPro, Dual, and others make terrific 80286- and 68000-based boards; I've yet to find a manufacturer or dealer that will bundle UNIX with an S-100 processor board. I even went so far as to call Microsoft to hear about the fabled XENIX, only

(continued)

# 6 TIMES FASTER!

## SuperFast Software Development Tools

### INCREASE YOUR PROGRAMMING EFFICIENCY

with high-performance software development products from SLR Systems.

No other tools approach the speed or flexibility of the SLR Systems line.

"Z80ASM is an extraordinary product...",  
Robert Blum, Sept. 84 DDJ

"...In two words, I'd say speed & flexibility",  
Edward Joyce, Nov. 84 Microcomputing

### ASSEMBLERS

- RMAC/M80 macros
- Nested INCLUDES & conditionals
- 16 char. labels on externals
- Built in cross-reference
- Optional case significance
- Phase/dephase
- Math on external words and bytes
- Define symbols from console
- Generate COM, HEX, SLR-REL, or Micro-soft-REL files
- Time & Date in listing
- Over 30 configure options

### LINKERS

- Links SLR & M80 format files
- Output HEX or COM file
- Three separate address spaces
- Load map and SID/ZSID .SYM file
- Works with FORTRAN & BASIC
- Generate PRL & SPR files
- Supports manual overlays
- Full 64K output address spaces

Z80ASM -full Zilog Z80	\$125
NEW! Z80ASM+ -all tables virtual	\$195
NEW! SLRMAC -full Intel 8080, with Z80.LIB extensions internal	\$125
NEW! SLRMAC+ -all tables virtual	\$195

Z80 CPU, CP/M compatible, 32K TPA required.

Inquiry 348

"Z80ASM...a breath of fresh air...",  
Computer Language, Feb. 85

SLRANK -fastest memory based	\$125
NEW! SLRANK+ -full featured virtual	\$195

Combo Paks available from \$199 - \$299.

For additional information contact SLR Systems

1-800-833-3061, in PA (412) 282-0864  
1622 N. Main St., Butler, PA 16001 • Telex 559215



C.O.D., Check or Money Order Accepted

# SLR Systems



# SIGN-MASTER™

## Number 1 in word charts for presentations and reports

Create powerful headlines using SIGN-MASTER's color, size, and font options. Here we chose Bold Roman font.

Highlight a single character, word or an entire line at the touch of a button. Here we focus attention on one number with color and underline.

Indicate source, date, author, etc. with SIGN-MASTER's footnote option. Bold Standard font was used in this example.

**THE BOTTOM LINE**  
PROJECTED EARNINGS  
(Millions of \$)

	'78	'79	'80	'81	'82
Sales	86.4	121.0	144.0	163.8	182.0
Net Income	5.9	8.8	11.4	13.4	15.7
ROS(%)	6.9	7.3	7.9	8.2	8.6
Mkt. Share	48%	61%	65%	71%	76%

Capital expenditure required: \$5 Million  
Net present value = **\$24.25** Million  
(opportunity cost of capital = 24%)

(Source: Annual Report)

Develop professional tables quickly and easily. Once data and text is entered, SIGN-MASTER determines the spacing and layout.

Produce SIGN-MASTER word charts on paper, overheads or slides.

With SIGN-MASTER, the possibilities are unlimited:

**CASUAL USER MARKET**

1st Time Buyer

Yearly Purchase Rate Estimate

Year	1978	1979	1980	1981	1982
1st Time Buyer	100	100	100	100	100
Repeat Buyer	100	100	100	100	100

Proposals

**SUMMARY FINANCIAL DATA**

	1978	1979	1980
SALES REVENUE	\$18,000	\$28,000	\$35,000
COGS	\$18,000	\$18,000	(\$3,000)
GROSS PROFIT	\$0	\$10,000	\$38,000
OPERATING EXPENSE	\$25,000	\$18,750	\$23,000
NET INCOME	(\$25,000)	(\$8,750)	\$15,000
EPS	(\$2.50)	(\$0.875)	\$1.50

Summaries

**Table 1: REVENUE MIX**

(Millions of dollars)

Product	1978	1979	1980
Product A	\$10	\$12	\$15
Product B	\$5	\$7	\$9
Product C	\$3	\$4	\$5
Product D	\$2	\$3	\$4
Product E	\$1	\$1	\$1
Product F	\$0	\$0	\$0
Product G	\$0	\$0	\$0
Product H	\$0	\$0	\$0
Product I	\$0	\$0	\$0
Product J	\$0	\$0	\$0
Product K	\$0	\$0	\$0
Product L	\$0	\$0	\$0
Product M	\$0	\$0	\$0
Product N	\$0	\$0	\$0
Product O	\$0	\$0	\$0
Product P	\$0	\$0	\$0
Product Q	\$0	\$0	\$0
Product R	\$0	\$0	\$0
Product S	\$0	\$0	\$0
Product T	\$0	\$0	\$0
Product U	\$0	\$0	\$0
Product V	\$0	\$0	\$0
Product W	\$0	\$0	\$0
Product X	\$0	\$0	\$0
Product Y	\$0	\$0	\$0
Product Z	\$0	\$0	\$0

Exhibits

**EXHIBIT 1**

**EXHIBITION ELECTRONICS**

Product Development Schedule

Product	Start	End
Product A	1978	1979
Product B	1979	1980
Product C	1980	1981
Product D	1981	1982
Product E	1982	1983
Product F	1983	1984
Product G	1984	1985
Product H	1985	1986
Product I	1986	1987
Product J	1987	1988
Product K	1988	1989
Product L	1989	1990
Product M	1990	1991
Product N	1991	1992
Product O	1992	1993
Product P	1993	1994
Product Q	1994	1995
Product R	1995	1996
Product S	1996	1997
Product T	1997	1998
Product U	1998	1999
Product V	1999	2000
Product W	2000	2001
Product X	2001	2002
Product Y	2002	2003
Product Z	2003	2004

Schedules

**FINANCIAL SUMMARY**

Item	1978	1979	1980
Income Statement	\$100,000	\$150,000	\$200,000
Net Sales	\$100,000	\$150,000	\$200,000
COGS & Other Exp.	\$50,000	\$75,000	\$100,000
Operating Expenses	\$25,000	\$37,500	\$50,000
Other Expenses	\$25,000	\$37,500	\$50,000
Operating Profit	\$25,000	\$37,500	\$50,000
Net Income	\$25,000	\$37,500	\$50,000
EPS	\$2.50	\$3.75	\$5.00
Balance Sheet	\$100,000	\$150,000	\$200,000
Assets	\$100,000	\$150,000	\$200,000
Liabilities	\$100,000	\$150,000	\$200,000
Equity	\$100,000	\$150,000	\$200,000
Debt	\$100,000	\$150,000	\$200,000
Equity	\$100,000	\$150,000	\$200,000
Debt	\$100,000	\$150,000	\$200,000
Equity	\$100,000	\$150,000	\$200,000
Debt	\$100,000	\$150,000	\$200,000
Equity	\$100,000	\$150,000	\$200,000
Debt	\$100,000	\$150,000	\$200,000
Equity	\$100,000	\$150,000	\$200,000
Debt	\$100,000	\$150,000	\$200,000
Equity	\$100,000	\$150,000	\$200,000

Tables

**NEW PRODUCT PROPOSAL**

For the Introduction of the

*Buzzer*

A Backyard Chain Saw for the Growing Casual User Market

Title Pages



SIGN-MASTER is the first program designed to allow everyone from top management on down to produce colorful, attention-gaining "word charts" and tables for presentations and reports.

Created on an IBM PC with a compatible plotter or printer, SIGN-MASTER word charts are superior in quality to typing and less expensive than typesetting or printing.

### Professional Word Charts Made Easy

In just minutes, this unique menu-driven program lets you create impressive, easy-to-read documents using words, numbers, lines and SIGN-MASTER's simple-to-master Table Mode.

### Number 1 in Quality Text

SIGN-MASTER offers the greatest variety of text options. In addition to 6 fonts, 16 sizes and 8 colors, you can justify text, underline, italicize, set margins, spacing, and more.

### An Important Presentation Tool

With SIGN-MASTER and any one of over 40

plotters, you can produce full color originals on paper and overheads. The program also works with most popular printers to create the highest quality printer graphics possible.

### Make Super Slides Quickly and Economically

Presentation-quality 35mm slides can be created in-house and inexpensively using the Polaroid Palette in conjunction with SIGN-MASTER.

For reports and presentations that get noticed, get SIGN-MASTER — Number 1 in word charts.

The retail price is \$245.00. Call or write today for a complete information kit and a demonstration at your nearest dealer. Decision Resources, Inc., 25 Sylvan Road South, Westport, CT 06880 (203) 222-1974

Inquiry 112

The developers of CHART-MASTER  
**DecisionResources**  
Software Designed for Decision Makers





## CHAOS MANOR MAIL

to be told that it was sold to hardware manufacturers and vendors only and that I should contact a dealer with my needs. Sigh, I haven't found a dealer who will sell UNIX with a processor only.

I can't accept that my interests are so strict and narrow as to completely cut me out of the mainstream of the micro marketplace—there are just too many *whole* systems (68000 or 80286 running UNIX) available as business systems for those with the money to spend. What I can accept is that the market for do-it-yourself systems integrators is dwindling; people are buying more prepackaged systems and doing their own less. It is also far more lucrative to *sell* prepackaged systems and unbelievably easier to support the same.

It would be possible for me to finance the purchase of a PC AT and find UNIX for it, but I've no way of knowing what compromises were designed into it, nor would I know if the UNIX was just transported 8086 code or an honest rewrite to take advantage of the new features in the 80286. (My feelings on the PC are quite strong—the only thing IBM did was take

a mediocre design and turn it into *the* standard for PCs. It could have done a *much* better job; I'd rather build my own.)

I could go on ad nauseam, but I'm sure you get the drift: we're a dying entity being replaced by the bundlers of PCs, Lotus and such. There is much being published on computing, but much on these *products*, rather than the internals of the machines themselves. It comes down to a definition of hobbyist.

MARK PILON  
POB 105  
Golden, CO 80402

*You have quite a problem; I expect that Steve Ciarcia would be more help than I can be. Or maybe one of the readers can help.*—Jerry

### AWARD WINNER

Dear Jerry,

This gem accompanied the Pro-Digical spreadsheet program we recently bought. It's one of the more interesting software license provisions I've seen.

"You may not attempt to discern any of the software concepts or architecture from the software."

MICHAEL E. MACMILLAN

*Ye gods: if the goal of Why Systems Inc. is to get people to ask "why?" on the theory that it will make their name memorable, they've succeeded. Herewith they receive my annual crumpled floppy award for the silliest license agreement yet. The rest of the agreement is standardly stupid; this provision is what wins for them.*

Thanks.—Jerry

### COMPUTER STORES

Dear Jerry,

Your sympathy for full-price computer store owners is misplaced. As long as computer stores hire teenage technobabblers, reject shoe salesmen, ham-handed repairmen, and other incompetents, and as long as it is cheaper and more cost-effective to get unassembled components in boxes via UPS than to lug

### CAD SYSTEM

**2D Starting at \$9,999.99**  
**3D Also Available — CALL**

All Plotters, Digitizers, Software and Training, one place for all your needs.

### COMPUTERS

IBM PC 64K 1 DR	\$1449
IBM PC 256K 2 1/2 HT DR	\$1630
IBM PC 256K HT DR + 10 MB	\$2699
SANYO 555-2 (2) DS/DD+SOFTWARE	\$999
SANYO 555-2 (2) DS/DD+MON+8	\$1399
IBM PC XT 256K	\$3848
IBM PORTABLE	CALL
SANYO 555-2+COL MON	
+5 SOFTWARE	\$1599

### SOFTWARE

SYMPHONY	\$469
LOTUS 123	\$285
dBASE II/III	\$289/\$398
WORD STAR PROPACK	\$348
OTHER SOFTWARE	CALL
R BASE	CALL

### MONITORS

AMDEC 310A	\$165
AMDEC 11+	\$415
PRINCTON GRAPHIC HX 12	\$469
SANYO	\$149
TAXAN RGB	\$448
PGS MAX 12	\$195

### DISKETTES

VERBATIM DS/DD	\$25.85
VERBATIM SS/DD	\$19.79

### PRINTERS SPECIALS

CABLE	\$19
OKIDATA 92P	\$395
OKIDATA 93P	\$625
EPSON FX100/80	very very low
BROTHER HR 15/HR 25	\$398/659
BROTHER HR 35	\$898
DTC STYLE WRITER 35K BUF	\$499
DTS 380Z + 48K BUFF	\$933
EPSON LQ 1500	very very low

### MODEM SALE

HAYES 1200 MODEM	\$480
HAYES 1200B	\$397

1200 BAUD Auto Dial, Auto Answer, Auto Log On, File Transfer, Printing, Call Progress, Monitoring, Auto Baud Rate Selection For IBM PC, XT Portable and Compatible. Made in Sunnyvale U.S.A. Dealer inquiries welcome. **\$249**

**WE'LL BEAT ANY  
ADVERTISED PRICE**

(IF WE BOTH HAVE IN STOCK)

**800-621-0854 x 905**

**800-272-0045 (Calif. only)**

### DISC DRIVES

EVEREX COGITO 10 MB INTL	\$848
SIGMA 10 MB INTERNAL	\$875
TEAC - 1/2 HT for IBM 360K	\$149
SHUGART 455 for IBM 360K	\$155
TANDON 100-2	\$170
IBM DISC DRIVE	\$199
CDC DRIVE for IBM	\$195
TEC 1/2 HT for IBM 360K	\$135

### HARDWARE

PC PEACOCK	\$234
HERCULES CARD	\$313
64K RAM SET	\$42
AST 6-PACK 64K/256K	CALL
AST MEGA PLUS II 64K	CALL
KEY TRONIC KEYBOARD 515 I	\$209
TELMAR GRAPHICS	\$485
EVERX BOARD	CALL
OTHER HARDWARE	CALL
SIGMA MAXMISER	\$249
8087 CHIP	\$178
QUAD BOARD	\$278
PLANTONIC PLUS	\$385

**LEASING ARRANGED UP TO \$1 MILLION AT LOW RATES. CAN INTRODUCE YOUR NEW PRODUCTS TO MARKETS. UPGRADE YOUR PRESENT COMPUTERS WITH 10MB PLUS HARD DRIVES. COMPANY P.O. WELCOME. MC/VISA + 3% CASH PRICES SUBJECT TO STOCK ON HAND. OPEN 7 DAYS.**

## ADVANCED COMPUTER SYSTEMS

Sunnyvale  
Fremont  
San Francisco  
Walnut Creek

665 Grape Ave. (408) 732-6200  
39138 State St. Town & Faire Center  
690 Market St. (415) 397-1311  
1987 No. Main St. (415) 945-8011

them home from a full-price computer store, they deserve to fail.

Other types of consumer businesses long ago developed into effective merchandisers. The result is that discounters, mail-order houses, and full-service retailers successfully coexist. When we pay full price for a stereo at DeLuxe Sound, it is because we receive value that Curbstone Discount does not offer, and it was worth the price difference. Often that difference is simply the knowledge that our needs were met by an effective product combination in an appropriate price range backed by a reputation of quality service, and that the transaction was accomplished treating us as intelligent human beings rather than suckers to be bilked.

I am a consumer who has too often found that Compu-Bilk and their ilk fail to provide the services they accuse the discount stores of not providing. Often the discount stores and mail-order houses provide a level of service that I earnestly wish I could get at my local full-price store! As a long-term computer professional, who for a variety of reasons shops in camouflage, I can usually tell when computer store salespeople are simply trying to extort. The average consumer feels this too, no doubt, in an undirected uneasiness that translates into the behavior your commentary discusses and store owners deplore.

When full-price computer stores make it clear to consumers what they get for their money, and if that something is of value to the consumer, the full-price computer stores will survive. Too many computer-savvy people think that consumer marketing is easy and they can make a killing selling them. Evidence of this attitude is your own lament in the same article about product pricing. Add the observation that the inexpensive Borland products were available only by mail order, in spite of strong marketing, until they became hot items and the verdict is guilty. If they fail to repent, they will continue to go out of business.

The halt, lame, and starving of the world need our sympathy and good works. Let's not waste them on the smug and greedy who don't!

RICHARD L. SWANSON  
North Bend, WA

*It depends on the store, of course; I've written my share of diatribes against the smooth-talking imbeciles who don't know a ROM from a cable designation. However, when good stores do hire knowledgeable salespeople and try to provide full service, I'd like to see them succeed.*

*Perhaps you're correct; I may have exaggerated the problem. I hope so.—Jerry*

### MORE ON COPY PROTECTION

Dear Jerry,

People discussing the justifications of copy protection often compare software to books. Proponents of copy protection argue that book owners hardly expect unlimited copying privileges or expect free replacements for lost or destroyed books, so why should software owners expect these privileges? What they say has an element of truth but misses an important point: books are rugged, and floppy disks are fragile. If you were to leave a book on the dashboard of your car in the hot sun for four hours, then take it out, drive over it once or twice, then dribble a little coffee on it, you could still curl up with it that night and have yourself a good read. A floppy disk would hardly fare as well under such abuse. Furthermore, if a word or two of a book were somehow smudged or made illegible, the remaining information in the book would scarcely be compromised, but a garbled byte or a bad sector on a disk could render the whole disk unreadable or ruin the program. Copy protection may or may not be defensible, but I don't think that the justification can be based on a comparison between floppy disks and books.

GARTH WARE  
Encinitas, CA

*Well said. I agree. Thanks.—Jerry*

### WORDSTAR TIPS

Dear Jerry,

You have mentioned that WordStar's global reformat command is grossly slow. There is no explicit global reformat command in WordStar (that I know of), so I presume you are using ^Q^Q^B to repeat the ^B (paragraph reform) command until interrupted by an <ESC> (or other key-stroke). This is indeed quite slow, but part of the reason is that ^Q^Q<key> pauses between each execution of <key> to allow the user to observe the effects so far and decide whether/when to interrupt the repetition. If there are many short paragraphs, ^Q^Q^B spends much more time pausing than reforming.

However, a digit keystroke (1-9) following ^Q^Q^B adjusts the duration of the pause. A "1" gives no perceptible pause and speeds global reformatting quite a bit. (^OH is also needed to prevent hyphen-help from stopping the reformatting for

hyphenation. I have patched my WordStar working copies to default to hyphen-help off to avoid this.) Global reformatting is still not blindingly fast because of the screen rewrites after many ^Bs. But since WordStar can handle a large document in a single file, no operator attention is needed. So when I need a global reformat, I just take a break while the computer does what it's best at! If you haven't tried the speed adjustment on the ^Q^Q^B, you may be in for a pleasant surprise.

KIRK A. MATHEWS

*Thanks for the tips. WordStar is a pretty good editor; at least, WordStar 3.3 with Orchid's PCTurbo 186 board really zings. I still use WRITE on 8-bit for most of my work, but when I do need to use the PCTurbo 186 I've actually got sort of fond of WordStar. Thanks.—Jerry ■*

#### USERS GROUP CORNER

CANADIAN SANYO USER GROUP  
c/o RYTE Data  
Box 210 Mountain St.  
Haliburton, Ontario K0M 1S0  
Canada

MAC STREET JOURNAL  
NY MacUsers' Group  
POB 6686 Yorkville Station  
New York, NY 10128

NULL-BABEL  
Independent Newsletter for CBASIC  
Users  
c/o Ric Allen  
799 Converse Dr.  
Cincinnati, OH 45240

CENTRAL KENTUCKY  
COMPUTER SOCIETY  
Suite 100, Security Trust Bldg.  
Lexington, KY 40507

TIPC USERS GROUP (TI Professional)  
4212 San Felipe Rd., #287  
Houston, TX 77027

PSU INTERNATIONAL (Victor 9000)  
Joe and Ann Reid  
POB 3244  
Scottsdale, AZ 85257

WASHINGTON AREA RAINBOW  
USER GROUP (DEC Rainbow)  
6415 Adelphi Rd.  
University Park, MD 20782



**THE FOOL PROOF  
XT/PC  
TAPE BACKUP**

**THE WORLD OF PC UPGRADES**

MT10	10 Mbyte Micro Tape Backup "add it to your XT"	\$695
XT01	Micro Tape Backup and 1/2 High Floppy "add it to your XT"	\$895
IS10	10 Mbyte Hard Disk with Controller	\$795
IS10R	10 Mbyte Removable Hard Disk/Controller	\$1295
IS20	20 Mbyte Hard Disk with Controller	\$1095
IS33	33 Mbyte Hard Disk/Controller & Power Supply	\$1995
ISPS	Power Supply "Internal" (140 watts)	\$295
CC01	Floppy/Hard Disk/Controller Card (1.6 Meg Floppy Compatible)	\$465
	when included in any of above Hard Disk Systems add	\$185

NOTE: The above pricing is for internal units. External units are available. Micro Design International has been serving the Computer Industry for over 8 years and all our products carry a one year warranty with a 30-day money back guarantee.

**MAGNETIC MEMORY  
PRODUCTS FOR THE  
IBM XT/PC AND  
COMPATIBLES. . .**

FROM **\$695**

**FREE**

WITH THE  
PURCHASE  
OF ANY  
HARD DISK

**COMMAND**  
**ASSIST** \$49.95  
(DOS manual on disk)  
...as reviewed in P.C. Week

**AND**

**CACHE**  
**ASSIST** \$49.95  
(For faster disk access)

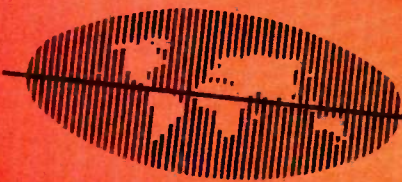

TO ORDER CALL COLLECT  
(305) 677-8333  
MasterCard/Visa/Check/or Money Order

**Micro Design International Inc.**  
6566 University Blvd., Winter Park, Florida 32792  
Inquiry 259 (305) 677-8333



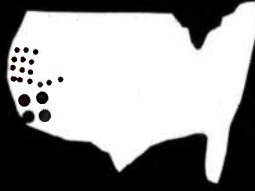

## Lasers, Office Publishing, and More

Interleaf's  
OPS-2000 and  
TPS-2000  
FastFinder

BY JOHN MARKOFF  
AND  
PHILLIP ROBINSON

If you want to be "in," introduce something that uses both a microcomputer and the Canon laser-printer engine. That inexpensive, high-resolution, fast, and silent descendant of the copying machine is popping up everywhere. Last spring Hewlett-Packard introduced its LaserJet printer—based on the Canon engine. In January Apple unveiled the Macintosh Office (see our article "The Macintosh Office" in the February BYTE, page 120) and its LaserWriter printer—based on the Canon engine. In the meantime, several other companies have announced laser printers for the IBM Personal Computer (PC) market based on—you guessed it. Plenty of people are betting that the laser printer will take a huge bite out of the daisy-wheel market.

Another, more expensive, way to be "in" is to find an application for the Sun Microsystems workstation. As we mentioned in the January BYTE West Coast ("Light Touches," page 415), that powerful 68010-based microcomputer has impressive graphics, windows, and speed.

So what would be the ultimate "in"? Right again—combine the Canon laser printer and the Sun workstation. Interleaf's Office Publishing System (OPS-2000) and Technical Publishing System (TPS-2000) do just that. Interleaf, based in Cambridge, Massachusetts, is . . . Wait a minute. Did someone say, "Cambridge isn't West Coast?" Well, we anticipated some such opportunistic heckling, and we have some answers.

Much of the Interleaf publishing package comes from right here in Silicon Valley. Ideas and components derive from Xerox Corporation—particularly its famous Palo Alto Research Center (PARC). Alto and Star features, such as icons, windows, and object-action processes, are fundamental to the Interleaf software. And we weren't the only ones to notice; at the Interleaf system demonstration in Menlo Park, we heard a potential customer muttering, "This looks more like Xerox than Xerox." Some of the folks at Interleaf came from Kurzweil Com-

puter Products back east (responsible for the famous reading machine), but there's even a connection there. Xerox bought Kurzweil. Finally, we're fascinated by the competition that is shaping up between the Star clones: both inexpensive machines like the Macintosh and expensive machines like these Interleaf systems.

Interleaf introduced the OPS-2000 system in the summer of 1984 and is now showing off the new, more powerful TPS-2000 system. The TPS-2000 is built around the same hardware as the OPS-2000 but it has improved software. It features new I/O (input/output) support: an optional optical scanner (to convert images into bit-map displays for editing and printing) and a phototypesetter interface. Either system lets you create text and graphics, combine them into documents, and print them on a laser printer.

In general, the idea behind both the Interleaf and Apple systems is that you won't have to take office documents outside the office to typeset them. The print quality from the laser is high enough that you can use its output for forms, reports, proposals, and manuals. (Besides, the printer can produce eight pages a minute.) The Sun workstation screen displays 75 dots per inch; the laser printer prints 300 dots per inch; and a phototypesetter produces 1000 dots per inch or more.

Does office publishing sound like a narrow, specialized field? Interleaf believes that office publishing is a billion-dollar industry that will grow to 8 billion dollars by 1988.

### HARDWARE

The Sun workstation with the Sun 2 processor card runs the Interleaf shell (which is written in C) under Berkeley 4.2 UNIX. The shell has its own windows and doesn't let you run other applications concurrently. However, to run another program all you have to do is get back to UNIX. That's easy. In fact, even without any help, the system

(continued)

BYTE West Coast is prepared monthly by BYTE's editors and staff in San Francisco and Palo Alto. Correspondence should be addressed to BYTE West Coast, BYTE Magazine, 425 Battery St., San Francisco, CA 94111.



did it several times during the demonstration.

A three-button optical mouse is used to control most of the work on the 19-inch diagonal screen. The 900-by 1152-pixel screen yields the high (75 dots per inch) resolution and a high spoilage factor. What's spoilage? That's what you feel when you play

with a superb, expensive machine like this and then have to go home to a bare-bones Kaypro.

The basic Sun workstation has 2 megabytes of RAM (random-access read/write memory) and ROM (read-only memory) and is accompanied by a 42-megabyte hard disk. If the two terminals you can attach to the

42-megabyte system aren't enough, buy the 130-megabyte disk; then you can attach as many as 15 terminals (if you can afford them). Each Sun workstation costs about \$22,000. The OPS-2000 system with software, one workstation, printer driver, printer, and lots of support and instruction runs about \$52,000. The scanner and scanned-image editing option costs \$40,000. The digital-typesetter interface that sets type and produces camera-ready pages (supporting Monotype, Compugraphic, Autologic, and Information International typesetters) begins at \$7500, the laser printer at \$14,500.

Although Interleaf specializes in turnkey systems, the company is happy to discuss other deals—particularly if you already have a Sun workstation. If you want to use other computers, a simplified version of the OPS-2000 software is available now for Apollo systems—both the bit-slice and the 68000 versions. According to Interleaf software engineer Roch Skelton, ports to other systems are in the works.

The Imagen printer controller accepts fonts, bit maps, and ASCII (American Standard Code for Information Interchange) characters from the Sun workstation and rasterizes them. That is, it converts them into one big bit map for the Canon printer. Skelton notes that the rasterization software is Imagen's, but "We're helping them develop and fix their software." Imagen, by the way, is another one of the many companies populated by refugees from Xerox.

The Imagen printer-controller box has about the same volume as the Canon printer but is shorter and longer. Inside it is a 68000-based computer and 1.25 megabytes of memory. It also interfaces with the new Ricoh Corporation laser-printer engine. Its specifications are about equivalent to the Canon's, but, according to Interleaf, Ricoh has a stronger market in Europe.

By summer 1985 we should see laser printers capable of 600- to 800-dot-per-inch resolution. Interleaf is using such a printer with its own systems. This resolution approaches that

# FINALLY!

## Communications Hardware and Software that's Inexpensive, Easy to Use and Guaranteed.



"The Amazing SpiderNet... an incredible amount of utility available to almost any small-sized application"  
Ron Exner, 12/84 *Hardcopy*

### SNARE™—SpiderNet's Callback Security System

- Protects ANY dialup computer system from unauthorized intruders
- Authorized users are called back at specific locations
- SNARE secures three modem lines at less than \$200/line
  - Up to three separate computers can use SNARE simultaneously
  - Uses Hayes-compatible modems or others like DEC's DF03
  - Stores 70 authorized users, expands to 150 (300+ soon)

\$595

### SpiderNet—Printer/Plotter Sharing Unit

- Shares expensive RS-232 plotters, daisy wheel or laser printers
- Makes laser printers affordable for your office or department
- Two to five micros or minis can share a peripheral
- Connect and use—no software modifications required!
- Optional 64K buffer for spooling

\$495

### SpiderNet—Computer and Peripheral Networking

\$495

- Six port, intelligent software-controlled RS-232 switch
- Share multiple peripherals between systems
- Interconnect computers to share data and files
- Three pairs of ports can be connected simultaneously
- Links ports at different baud rates
- Programmable, perfect for custom RS-232 control application

### SpiderNet—Multiplexer, Terminal Concentrator and more

\$495

- Five to one RS-232 multiplexer/demultiplexer
- 5x1 or 4x2 concentrator for expanding terminal ports

### ENVOY™—Telecommunications Software

\$49.95

- Access to electronic mail, remote systems and data networks
- Error free, text and binary file transfers via XMODEM or ANSI X3.28
  - Smart terminal mode with capture buffer, autodial and autologin
  - Easy to use, menu driven, compact and high speed
  - Utilities menu for copy, type, print, erase and rename files
  - For IBM PC, PCjr, PC compatibles, Sanyo MBC-55X, CP/M-80 or -86

30-day money-back guarantee on all products

**ARTISOFT INC**

Box 41436, Tucson, Arizona 85717  
(602) 327-4305

Inquiry 32 for Dealers.  
Inquiry 33 for End Users.

at the low end of typesetting. Interleaf will use a Toshiba printer engine with a Dataproducts controller to produce up to 24 pages a minute by next year. Interleaf hopes to create its own printer controller, which it calls RIP, for Rasterizing Image Processor.

**SOFTWARE**

Both the OPS-2000 and the TPS-2000 accept text from IBM PCs, Wang word processors, WordStar, Scribe, Nroff, and Troff—in fact, just about any ASCII file. Interleaf has filter programs to massage text that doesn't arrive in usable condition. Documents within the Interleaf systems are saved as standard UNIX files and you can transfer them between UNIX systems using standard utilities. The attributes that dictate the document's format are stored in a separate *dot file*. Except for a leading period, the dot file has the same name as the ASCII file. The OPS-2000 also directly accepts Lotus 1-2-3 spreadsheet data via a special RS-232C connection and a communications program that are available from Interleaf.

The fonts occupy 2.5 megabytes of disk space and the software occupies another 5 megabytes. The basic OPS-2000 shell takes up 600K bytes of the internal memory; having it in RAM speeds up document formatting. Even 2.5 megabytes of font storage contains only two fonts: a serif style (called Classic) and a sans-serif style (Modern). And the font sizes only go up to 24 point. Future versions will include 36- and 72-point sizes, light and condensed fonts, and other improvements.

Interleaf claims to be ready to support color when the workstation and printer hardware can handle it. "It's an evolving product" was a sentence we heard repeatedly. Skelton kept referring to the many new features in the March software release—more fonts, new paint capacities, section numbering, document indexing, etc.

The OPS-2000 discriminates between four types of graphics: business graphics (charts and graphs that the OPS-2000 software produces), scanned images (input through the

special optical scanner that Interleaf sells), simple created graphics (boxes, lines, circles), and Calcomp 960 plotter graphics. Eventually, all of these will be interchangeable. However, the older version of the OPS-2000 has limitations for each. For example, scanned images can't be rotated and Calcomp 960 plots can't be filled

because the software doesn't recognize the edges of the figures as continuous. The Adobe PostScript/Apple LaserWriter combination and the Interleaf OPS-2000 are clearly different in that the former can print anything you draw on the screen, the latter cannot.

*(continued)*

**Change your diskette to fit the IBM PC**



**THE FILE CONNECTION**  
**8" DISKETTE SYSTEM FOR THE IBM PC**

Our "FILE CONNECTION" programs provide 8" diskette file exchange between the IBM PC and most Micro-Mini-Main Frame computer systems.

Our "WORD CONNECTION" programs provide 8" diskette text document exchange between the IBM PC and many word processing systems.

Our "DISPLAYWRITER CONNECTION" programs transform documents from Textpack, Wordstar, Multimate, etc. to the new DisplayWrite 2 format.

In addition to our hardware and program products, we also provide a conversion service for customer supplied diskettes. Please contact us for information about the hundreds of 5 1/4" and 8" diskette formats and systems which we currently support.

FLAGSTAFF ENGINEERING / P.O. Box 1970 / Flagstaff, AZ 86002  
 Telephone 602-774-5188 / Telex 705609 FLAG-ENG-UD



The OPS-2000 includes clip art and a wish book. The clip art is a library of diagrams, mathematical symbols, and graphics that you can use directly or modify. The wish book contains examples of 50 types of business charts that the system can use as a model for your own graphics. You can add your own chart types to it.

The OPS-2000 lets you size, duplicate, move, fill, and rotate images. It uses the same cut-and-paste scheme that the Macintosh employs. The TPS-2000 adds features for typesetting such as multiple-column capability and scaling. Two of the fonts are vector fonts that can be rotated and sized along with other diagramming

objects. Scanned images can be positioned, cropped, sized, rotated, shaded, blended, merged, air-brushed, silhouetted, textured, or overlaid with text.

The Interleaf system uses a series of fixed and floating rectangular windows called frames. [Editor's note: These frames should not be confused with artificial-intelligence frames.] A fixed frame is tied to a particular spot in the text stream and moves on the page when the text is edited. A floating frame is tied to a particular location on the page called an anchor. This frame stays put and the text flows around it. The user interface depends on object-action processes: you select an object—text or graphics—and use the pop-up menus to manipulate it.

# GIVE YOUR PC THE GIFT OF SIGHT.



Once installed, our electronic digitizing scanner allows you to capture images in high resolution. These can then be manipulated, stored, retrieved, and even printed.

But what's truly amazing is the range of applications for the Datacopy 700. Such as generating complex documents including text, drawings and pictures.

Until now, your PC was telling only half the story. Because no matter how you look at it, words and numbers are simply that: words and numbers.

But the Datacopy 700 changes all that. **TURN YOUR WORD PROCESSOR INTO AN IMAGE PROCESSOR.**

This remarkable peripheral enables you to combine photos, diagrams, even 3-D objects with word processing, data base, CAD and communications applications using standard software.

All you need to get the picture is an IBM XT, AT, or compatible. Our friendly, yet powerful, Word Image Processing System™ software is included in your purchase.



Technical manuals. Catalogs. Personnel or document files. Or what ever you decide.

The result is a visionary achievement: the power to give words and numbers far more meaning. To publish information, not just data. And to extend the possibilities of your PC. All for a surprisingly low cost.

For more details, call toll-free 1-800-821-2898 or in California 415-965-7900.

Or write to Datacopy Corporation, 1215 Terra Bella Avenue, Mountain View, CA 94043. Telex: 701994 DATA-COPY UD.



**DATACOPY**  
The Eye of the Computer

## WE'RE NOT DONE YET

Will Interleaf's expensive, powerful system win the hearts of office publishers? You can have many but not all of its special features for much less money in the Apple Macintosh Office. To some extent, you can even duplicate the scanner with peripherals such as the Thunderware image digitizer described in our February BYTE West Coast ("What's Next?" page 371). Still, for now the Interleaf systems are more complete and much faster than anything based on the Mac. What happens when the Macintosh gets some publishing software more powerful than MacWrite? We'll wrestle with that question in next month's BYTE West Coast when we look at Aldus Corporation's electronic paste-up and composition program, PageMaker.

## FASTFINDER: A MACINTOSH PROGRAMMERS' WORKSHOP

The Apple Macintosh software architecture is based on the concept of a visual shell that insulates you from many of the nuts and bolts of a traditional operating system. Most people are now familiar with the widely copied, mouse-driven, bit-mapped desktop display that Apple claims offers "radical ease of use." However, much of the criticism of the Macin-

(continued)



# Introducing the Most Powerful Business Software Ever!

TRS-80™ (Model I, II, III, or 16) • APPLE™ • IBM™ • OSBORNE™ • CP/M™ • XEROX™

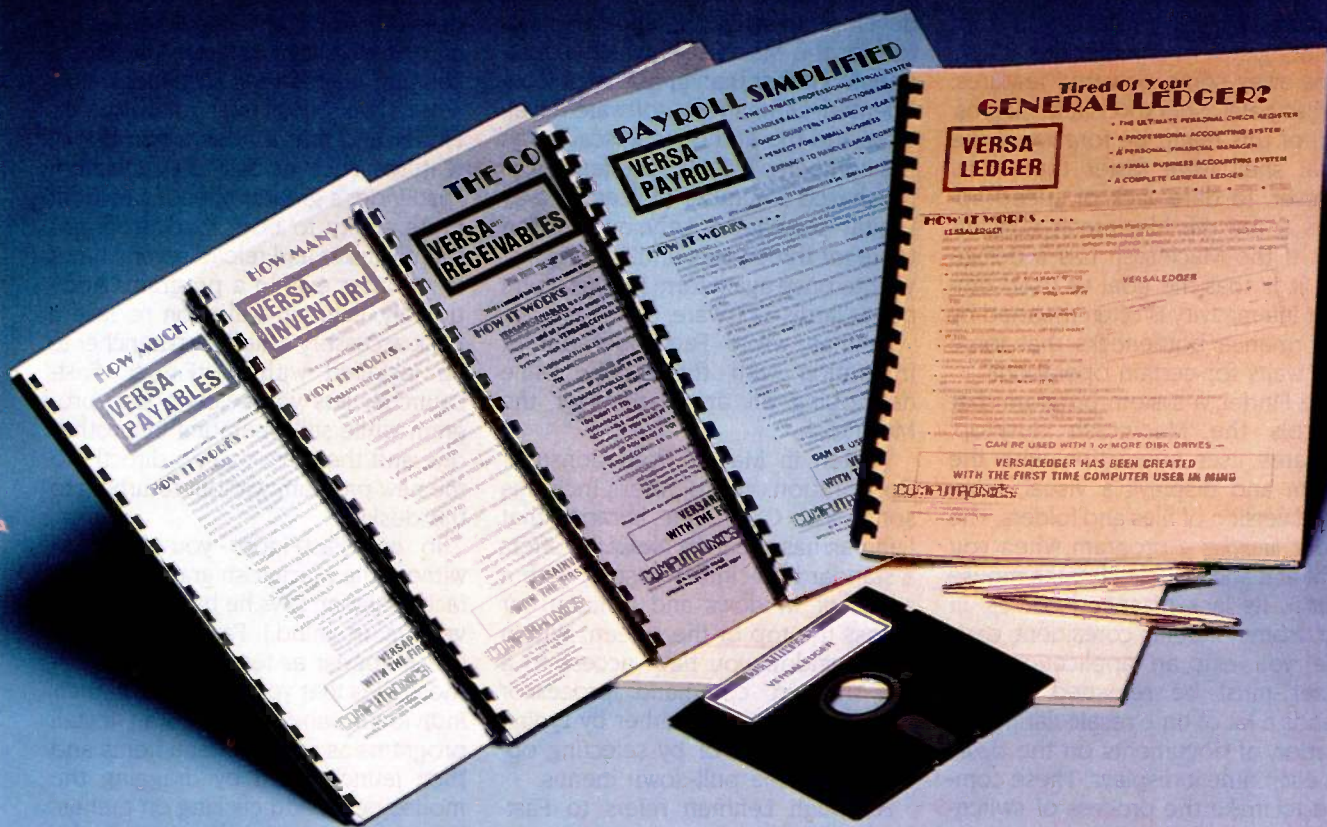

## The VERSABUSINESS™ Series

Each VERSABUSINESS module can be purchased and used independently, or can be linked in any combination to form a complete, coordinated business system.

**VERSARECEIVABLES™** \$99.95  
VERSARECEIVABLES™ is a complete menu-driven accounts receivable, invoicing, and monthly statement-generating system. It keeps track of all information related to who owes you or your company money, and can provide automatic billing for past due accounts. VERSARECEIVABLES™ prints all necessary statements, invoices, and summary reports and can be linked with VERSALEDGER II™ and VERSAINVENTORY™.

**VERSAPAYABLES™** \$99.95  
VERSAPAYABLES™ is designed to keep track of current and aged payables, keeping you in touch with all information regarding how much money your company owes, and to whom. VERSAPAYABLES™ maintains a complete record on each vendor, prints checks, check registers, vouchers, transaction reports, aged payables reports, vendor reports, and more. With VERSAPAYABLES™, you can even let your computer automatically select which vouchers are to be paid.

**VERSAPAYROLL™** \$99.95  
VERSAPAYROLL™ is a powerful and sophisticated, but easy to use payroll system that keeps track of all government-required payroll information. Complete employee records are maintained, and all necessary payroll calculations are performed automatically, with totals displayed on screen for operator approval. A payroll can be run totally, automatically, or the operator can intervene to prevent a check from being printed, or to alter information on it. If desired, totals may be posted to the VERSALEDGER II™ system.

**VERSAINVENTORY™** \$99.95  
VERSAINVENTORY™ is a complete inventory control system that gives you instant access to data on any item. VERSAINVENTORY™ keeps track of all information related to what items are in stock, out of stock, on backorder, etc., stores sales and pricing data, alerts you when an item falls below a preset reorder point, and allows you to enter and print invoices directly or to link with the VERSARECEIVABLES™ system. VERSAINVENTORY™ prints all needed inventory listings, reports of items below reorder point, inventory value reports, period and year-to-date sales reports, price lists, inventory checklists, etc.

**VERSALEDGER II™** \$149.95  
VERSALEDGER II™ is a complete accounting system that grows as your business grows. VERSALEDGER II™ can be used as a simple personal checkbook register, expanded to a small business bookkeeping system or developed into a large corporate general ledger system without any additional software.

- VERSALEDGER II™ gives you almost unlimited storage capacity (300 to 10,000 entries per month, depending on the system),
- stores all check and general ledger information forever,
- prints tractor-feed checks,
- handles multiple checkbooks and general ledgers,
- prints 17 customized accounting reports including check registers, balance sheets, income statements, transaction reports, account listings, etc.

VERSALEDGER II™ comes with a professionally-written 160 page manual designed for first-time users. The VERSALEDGER II™ manual will help you become quickly familiar with VERSALEDGER II™, using complete sample data files supplied on diskette and more than 50 pages of sample printouts.

### SATISFACTION GUARANTEED!

Every VERSABUSINESS™ module is guaranteed to outperform all other competitive systems, and at a fraction of their cost. If you are not satisfied with any VERSABUSINESS™ module, you may return it within 30 days for a refund. Manuals for any VERSABUSINESS™ module may be purchased for \$25 each, credited toward a later purchase of that module.

**To Order: Write or call Toll-free (800) 431-2818 (N.Y.S. residents call 914-425-1535)**

- \* add \$3 for shipping in UPS areas
- \* add \$5 to CANADA or MEXICO
- \* add \$4 for C.O.D. or non-UPS areas
- \* add proper postage elsewhere

Inquiry 177

DEALER INQUIRIES WELCOME

All prices and specifications subject to change / Delivery subject to availability.

# COMPUTRONICS!

50 N. PASCACK ROAD, SPRING VALLEY, N.Y. 10977

\* TRS-80 is a trademark of the Radio Shack Division of Tandy Corp. • APPLE is a trademark of Apple Corp. • IBM is a trademark of IBM Corp. • OSBORNE is a trademark of Osborne Corp. • CP/M is a trademark of Digital Research • XEROX is a trademark of Xerox Corp.



tosh design has focused on this visual interface. While it protects you from operating-system complexities, it also strips away some powerful features, such as batch operations and macros.

All of this might be forgiven if the visual shell were faster than it is; however, to date, lack of speed appears to be the Macintosh Achilles' heel. If the Macintosh has a design flaw, it is that the goal of user/computer interactivity is often thwarted by performance bottlenecks that force long waits for certain operations.

The Finder, a system program that controls the Macintosh desktop, mediates user interaction with the system and displays a visual, icon-based version of files and folders. The Finder *launches* a program when you point at it and double-click the mouse button. Its lack of speed comes, in part, from not being coresident; each time you exit an application, the Finder must be reloaded. It also spends a lot of time recalculating the location of documents on the desktop each time it displays. These combine to make the process of switching between applications cumbersome on the Macintosh.

Although Apple hasn't chosen to improve the Finder yet, there is now

an alternative. Michael Lehman has developed FastFinder, another desktop for the Macintosh, which is text-oriented rather than graphics- or icon-oriented. Lehman is a software developer and the author of Pascal/MT+. His company, MT Microsystems, was purchased a number of years ago by Digital Research. Lehman worked there for three years until leaving last year to once again form his own company, Tardis Software.

Lehman wrote FastFinder out of frustration with the Finder while developing an application for the Macintosh.

Written in Mac C from Consulair Corporation, FastFinder includes some Mac C run-time libraries that Lehman has specially *tweaked*. It offers a standard Macintosh display with a series of windows and a menu bar across the top of the screen. Within each window you have access to a line-oriented command processor that you can access either by typing at the keyboard or by selecting options from the pull-down menus.

Although Lehman refers to FastFinder as an "expert's alternative" and includes with it a number of features oriented toward Macintosh programmers who want to automatically link

operations in the process of program development, it also should appeal to anyone who wants a faster Macintosh. Lehman claims that FastFinder runs "up to five times faster" than Apple's Finder and that it adds a number of features such as fast disk ejection. FastFinder's greater speed is evident in its ability to both load programs slightly faster and reload several times faster after exiting a program. Additionally, Lehman will soon release a desk accessory called FastLauncher to be installed with FastFinder. FastLauncher lets you select a new program while still operating in another one and then lets you go directly to the new program without returning to the desktop.

To use FastFinder you must do without the Macintosh graphical interface. (Lehman says he has a graphical version in mind.) FastFinder directories appear as text-only in a list of those files that you can scroll in their individual windows. You can install programs as special menu items and then launch them by dragging the mouse down and clicking on menus; however, you must also give up the Macintosh document and folder metaphor for organizing files.

If you are doing program development on the Macintosh, FastFinder has a series of UNIX-like utilities that you can access from the menu or command line. Many of these commands are already available as small utility programs for the Macintosh; however, FastFinder makes them easier to use because you don't have to leave the desktop to use them. Others, such as combine, compare, and list, are not currently available.

FastFinder includes a scripting capability that you can call with the do command. The do command executes a series of FastFinder commands that can be created with a text editor or a special record command and then stored in a text file. FastFinder can also link applications under script control.

Now that he has finished FastFinder, Lehman is writing a Macintosh application generator for novice and expert programmers. ■

## COMPANIES MENTIONED

**CANON U.S.A. INC.**  
One Canon Plaza  
Lake Success, NY 11042  
(516) 488-6700

**IMAGEN INC.**  
2660 Marine Way  
Mountain View, CA 94043  
(415) 960-0714

**INTERLEAF INC.**  
1100 Massachusetts Ave.  
Cambridge, MA 02138  
(617) 497-5570

**KURZWEIL COMPUTER PRODUCTS INC.**  
185 Albany St.  
Cambridge, MA 02139  
(617) 864-4700

**RICOH CORP.**  
5 Dedrick Place  
West Caldwell, NJ 07006  
(201) 575-9550

**SUN MICROSYSTEMS INC.**  
2475 Garcia Ave.  
Mountain View, CA 94043  
(415) 960-1300

**TARDIS SOFTWARE**  
2817 Sloat Rd.  
Pebble Beach, CA 93953  
(408) 372-1722

**XEROX CORP.**  
POB 1600  
Stamford, CT 06904  
(203) 329-8700

# DISK DRIVES

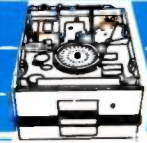

## Shugart

★ SA455  
★ 1/2 HT. PC Compatible  
**\$99**

## Teac 55B

★ Slimline 360K  
★ PC Compatible  
**\$119**

## Tandon TM100-2

★ Full HT, 360K  
★ PC Compatible  
**\$139**

## MPI

B-52, 360K ★ Full Height  
★ IBM Compatible  
**\$100**

## CCU Apple Drives

★ Slimline  
★ Fully Apple Compatible  
**\$140**

## 8" Siemens

★ FDD100-8  
★ Shugart Compatible  
**\$129**

### Apple Compatible Drives

	QUANTITY		
	1	2	10
<b>Micro Sci</b>			
A-2 or A-20 Full HT Controller	\$175	\$169	\$159
	65	60	50
<b>Rana Systems</b>			
Elite I	\$210	\$205	\$200
Elite II, Dbl. Head	335	330	325
Elite III, Quad Density	395	445	435
Controller Controls 4 Drives	75	70	70
<b>CCU Half Height</b>			
FD525A Slimline w/ cable	\$140	\$135	\$130
FD525C for IIC	169	169	169
<b>CCU Full Height</b>			
FD555A w/ cable	\$160	\$150	\$140
<b>Hard Disk</b>			
10 Meg w/ controller	Call	Call	Call

### 5 1/4" Disk Drives

	QUANTITY		
	1	2	10
<b>Teac</b>			
FD55A, 160K	\$110	\$110	\$110
FD55B, 360K	119	115	109
FD55F, Quad Density	159	150	140
All Teac's are Half Heights			
<b>Tandon</b>			
TM100-1, 160K	\$150	\$140	\$130
TM100-2, 360K	139	135	129
TM101-4, Quad Density	280	270	260
TM65-2, 360K 1/2 Height	195	190	185
<b>MPI</b>			
B-52, 360K PC Compatible	\$100	\$ 95	\$ 90
<b>Shugart</b>			
SA400, 160K	\$190	\$180	\$170
SA455, 360K 1/2 Height	99	95	90
SA465, Quad Den. 1/2 Height	200	190	180
<b>Mitsubishi</b>			
4851, 1/2 Height	\$159	\$149	\$139
4853, Quad Den. 1/2 Height	169	159	140
<b>Control Data Corp.</b>			
CDC 9409, 360K	\$190	\$180	\$170

### 8" Disk Drives

	QUANTITY		
	1	2	10
<b>Siemens</b>			
FDD-100-8	\$129	\$120	\$111
FDD-200-8	180	170	160
<b>Shugart</b>			
801R, Sgl./Dbl.	\$160	\$150	\$140
851R, Dbl./Dbl.	480	470	460
<b>Tandon</b>			
TM848-1E Sgl./Dbl. 1/2 Ht.	\$270	\$265	\$260
TM848-2E, Dbl./Dbl. 1/2 Ht.	370	360	350
<b>Mitsubishi</b>			
M2894-63, Dbl./Dbl.	\$400	\$390	\$380
M2896-63, Dbl./Dbl. 1/2 Ht.	400	390	380
<b>5 1/4" &amp; 8" Power Supply &amp; Cabinets</b>			
QUANTITY			
	1	2	10
<b>JMR 5 1/4"</b>			
Single Cabinet w/ pwr	\$ 70	\$ 60	\$ 50
Dual Thinline Cab w/ pwr	80	70	60
Dual Cabinet & Power	80	70	60
All have 6 month warranty			
<b>JMR 8"</b>			
Sgl. Cabinet w/ pwr & fan	\$220	\$210	\$200
Dual w/ pwr for 2 thinlines	230	220	210
Dual w/ pwr & fan	270	260	250

See Us At  
**Coast Computer Fair**  
March 30 — April 2  
Moscone Center  
San Francisco

CALL TOLL FREE  
**(800) 847-1718**

**Computer Components Unlimited**  
A California Corporation

Inquiry 71

**RETAIL STORES:**  
11976 Aviation Blvd.  
Inglewood, CA 90304

16129 Hawthorne Blvd, Suite E  
Lawndale, CA 90260

**MAIL ORDER:**  
P.O. Box 1936  
Hawthorne, CA 90250

**Customer Service & Technical**  
**(213) 618-0487**

**Sales Desk**  
**(800) 847-1718**  
Outside California

**(213) 618-0477**  
Inside California



# PRINTERS



## Okidata 92

- ★ 160 cps
- ★ NLQ Mode

**\$358**

\*FREE IBM Proms

### PRINTERS Epson

RX-80 (120 cps)	Save
RX-80FT	At Least
RX-100 +	\$150
FX-80 +	
FX-100 +	
LQ1500	
JX-80	\$ 589

We are an Authorized Dealer

### Okidata

OKI82A, 120 cps	\$ 295
OKI83A	549
OKI84P	669
OKI84S	749
OKI92P	359
OKI93P	589

Call for other Models  
FREE Plug 'n Play Roms w/92 & 93

### JUKI

6100, 18 cps Ltr. Quality	\$ 399
6300, 40 cps "New" w/3K Buffer	
Letter Quality	795

### Brother Dist. by Dynax

HR15XL, 12 cps	\$ 389
HR25, 25 cps	659
HR35, 36 cps	949

### Panasonic

1091, 120 cps w/ tractor	\$ 289
--------------------------	--------

### C. ITOH

8510AP	\$ 319
F10, 40 cps	929
Printmaster F1055pu	1179

### Star Micronics

Gemini 10X	\$ 259
Gemini 15X	389
Delta 10	379
Power type	390

### Toshiba

P1351, 192 cps	\$1289
----------------	--------

### PRINTER INTERFACES

#### Fourth Dimension

Card & Cable	\$ 49
--------------	-------

#### Microtek

Dumpling GX (Grappler Compatible)	\$ 89
Dumpling GX exp to 64K	149
Dumpling GX 16K w/ 16K exp to 64K	169
for each additional 16K	15

#### Okidata Options

Tractor for 82 & 92	\$ 59
Serial Interface	99

#### Orange Micro

Grappler +	\$ 109
Grappler + w/ 16K	179

#### Star or Epson

Epson Serial Interface	\$ 119
Star Serial Interface	59



## BMC 12AUW

- ★ 12" Green
- ★ Composite Video

**\$59**

### Amdek

300G, Hi-Res Green	\$ 139
300A, Hi-Res Amber	149
310A, Monochrome Amber	169
300 Hi-Res Color Comp.	279
500 RGB Composite	399
DVM Board for Apple RGB	129

### Princeton Graphics

MAX12, Monochrome Amber	\$ 179
HX12, RGB Color	459
SR-12 w/ Doublor Board	899

### IBM

Monochrome Green	\$ 219
Color Hi-Res	559

### Zenith

ZVM122	\$ 99
ZVM123	99

### BMC

12AUW	\$ 59
9191	219

### Taxan

425 Color RGB	\$ 399
440 Ultra Hi-Res	999



# MODEMS

## Hayes Modem

- ★ 1200 Baud
- ★ Stand alone RS232

**\$389**

### Hayes

Micro Modem IIE	\$ 229
300 Baud	195
1200B Internal	359
1200	389
2400 Baud	Call

### Anchor Automation

Mark For TI	\$ 59
Mark VI 300 Baud IBM	79
Mark XII, 1200 Baud	229
Mark 10, 300 Baud Stand alone	149

### Prometheus

Promodem	\$ 329
Pro 1200A Apple Int w/sw	329
Pro 1200B IBM Int w/sw	299
Pro Mac w/ cable & sw	329
No. C Cable	12
Alpha Disp.	89
Options Proc.	89

### U.S. Robotics

Password	\$ 239
----------	--------

Computer  
Components  
Unlimited  
A California Corporation

Inquiry 72



No Surcharge for Credit Cards

All Prices Reflect a Cash,  
Pre-Paid Discount

This Ad Supersedes All Others

Customer Service & Technical  
(213) 618-0487

Sales Desk  
(800) 847-1718  
Outside California

(213) 618-0477  
Inside California

# SYSTEMS

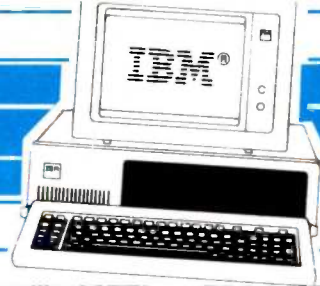

## IBM PC System

- ★ 256K Memory
- ★ Two 360K Drives

**\$1539**

## IBM PC System

- ★ 256K Memory
- ★ Two 360K 1/2 Heights
- ★ One 10 MB Hard Disk

**\$2298**

## IBM AT System

- ★ We have availability

**Call for  
Lowest Quote**

<b>Apple</b>	
IIE cpu	\$ 790
Macintosh	1895
IIC Portable	899

<b>Kaypro</b>	
Kaypro II	Call
Kaypro 4	Call
Kaypro 10	Call
Kaypro IIX	Call

<b>IBM</b>	
PC 256K, No Drives	\$1250
PC 256K, 1 Drive	1399
PC 256K, 2 Drives	1599
XT w/10 Meg, 256K	3495
Additional Memory 64K	27
AT Standard Config.	Call
AT w/20 meg	Call

<b>Tava</b>	
PC Compatible w/Monitor	\$1395

<b>Sanyo</b>	
MBC 550-2	\$ 799
MBC 555-2	1089
Optional Serial Port	69
Optional 360K Drive	159

<b>Compaq</b>	
Portable (PC Compatible) 2, 360K Drives	\$2150
256K of Memory	\$2150
Call for all new Compaq's	

# IBM & APPLE ACCY'S

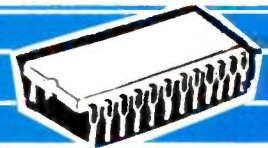

## SUPER SPECIAL 64K Upgrades

- ★ Nine Prime 4164
- ★ 1 Year Warranty

**\$19 set 1000 \$1.70 ea**

<b>IBM EXTRAS</b>	
<b>Ast Research</b>	
Six Pack +	\$ 249
Mega +	265
Add on Ports	49
<b>Hercules</b>	
Color Card	\$ 185
Graphics Card	329
<b>Hard Disk</b>	
10 Meg. External w/power supply	\$1195
<b>IBM</b>	
Monochrome Adapter	\$ 219
Color Card	239
<b>Paradise Systems</b>	
Multi-display Card	\$ 329
New Modular Card	299
Module A	88
Module B	240

<b>Quadram</b>	
Quad Color Card	\$ 199
Quadlink	389

<b>64K Upgrade</b>	
64K of Memory	\$ 19

<b>AT Upgrade</b>	
Upgrade 200 ns	\$ 169

<b>PC Products</b>	
PC Peacock	\$ 215

<b>Ports</b>	
Parallel	\$ 79
Serial	79

<b>CCU</b>	
Color Graphics Card	\$ 149

<b>APPLE EXTRAS</b>	
<b>ALS</b>	
Z Engine	\$ 119
CPM 3.0 Card	259

<b>Astar</b>	
RF Modulator	\$ 15
Fan w/Surge	34

<b>CCU</b>	
16K Mem. Card 1 yr war	\$ 49

<b>Kraft</b>	
Joystick	\$ 44

<b>Macro</b>	
Joystick	\$ 29

<b>Micro Max</b>	
Viewmax 80, 80 Col. card	\$ 139
Viewmax 80E (F for IIE) 64K	129

<b>Micro Soft</b>	
Mouse	\$ 139
Premium Soft Card IIE	369
Multiplan	189
Soft Card (Z80) w/64K	279

<b>Micro Tek</b>	
Serial Interface	\$ 89

<b>TG</b>	
Joystick	\$ 39
Select-A-Port	31
Paddles	34

<b>5 1/4" DISKETTES</b>	
<b>CCU</b>	
Sgl/Dbl reinforced hub	\$16 100 for 140
Dbl/Dbl reinforced hub	19 100 for 170
NOT Bulk Packed	

<b>Dysan</b>	
Sgl/Dbl	\$33 100 for 300
Dbl/Dbl	39 100 for 370

<b>Fuji</b>	
Sgl/Dbl	\$19 100 for 180
Dbl/Dbl	25 100 for 230

<b>Verbatim</b>	
Sgl/Dbl	\$26 100 for 240
Dbl/Dbl	36 100 for 340

<b>8" DISKETTES</b>	
<b>Dysan</b>	
Sgl/Sgl	\$34 100 for 320
Dbl/Dbl	53 100 for 480

<b>Verbatim</b>	
Sgl/Sgl	\$30 100 for 280
Dbl/Dbl	40 100 for 360

### RETAIL STORES:

11976 Aviation Blvd.  
Inglewood, CA 90304

16129 Hawthorne Blvd., Suite E  
Lawndale, CA 90260

### MAIL ORDER:

P.O. BOX 1936  
Hawthorne, CA 90250

Inquiry 72

### Retail Hours:

**10 a.m. - 6 p.m. Mon.-Fri.**  
**10 a.m. - 3 p.m. Sat.**

All merchandise new. We accept MC, Visa, Wire Transfer, COD Call, Certified Check, P.O.'s from qualified firms, APO accepted. Shipping: Minimum \$4.50 first 5 pounds. Tax: California Res. Only add 6 1/2% sales tax. All returns subject to 15% restocking charge. Advertised prices for Mail Order only. Retail prices slightly higher.  
Prices subject to change.

### Customer Service Hours:

**10 a.m. - 4 p.m. Mon.-Fri.**

**John Aurentz**  
**(213) 618-0487**

### Mail Order Hours:

**8 a.m. - 6 p.m. Mon.-Fri.**

**10 a.m. - 3 p.m. Sat.**

**(800) 847-1718 (213) 618-0477**  
(Outside California) (Inside California)



**Kimtron**

# MULTI-USER SOLUTION for IBM PC, XT, AT

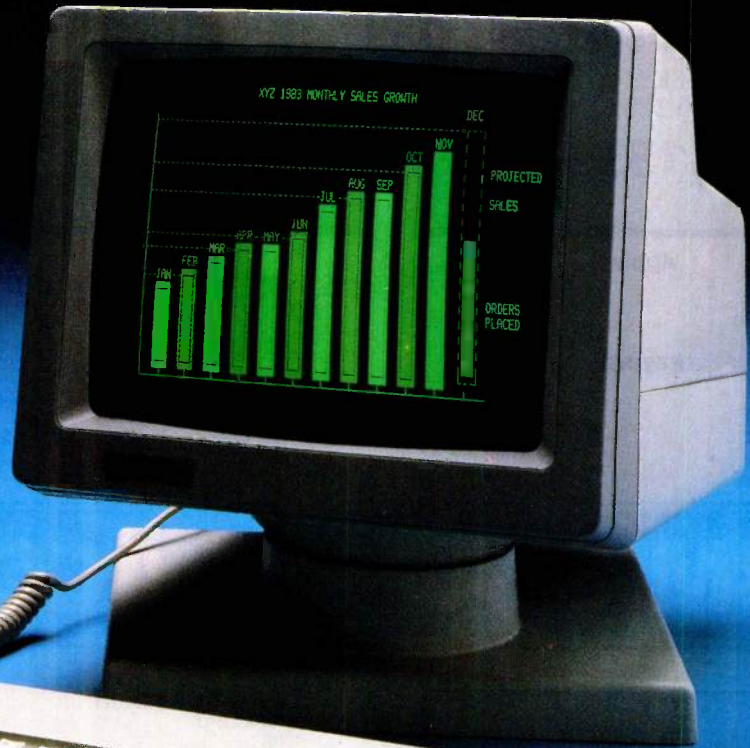
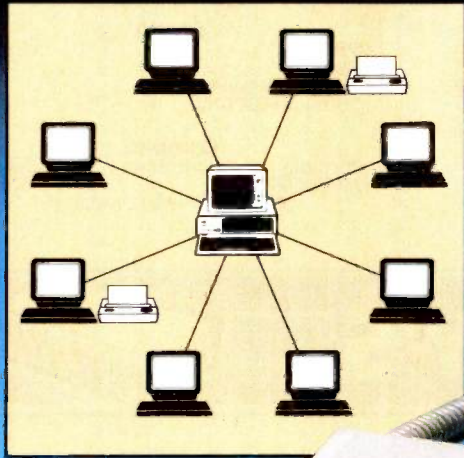

## Compare the Solution!

The Multi-User Solution of the future is now available.

Convert your IBM PC, XT, AT or Compatibles to a true multi-user system while maintaining display, keyboard and software compatibility.

Since the KT-7/PC display is the same as your PC monochrome monitor, with its look-alike keyboard, operators will feel they're using an IBM PC and can also use the same software manual. Kimtron's multi-user solution includes file and record locking, shared data access, and communication between users. It is **the** intelligent alternative.

The KT-7/PC supports Time Sharing, Enhanced Time Sharing

and Multi-Processor implementation under PC DOS, MS DOS, UNIX, XENIX, CPM 86, Multilink, Concurrent PC DOS, and other compatible multi-user operating systems.

Kimtron's multi-user solution may be tailored for cost effectiveness; as low as \$1095 for an additional user, and for speeds more than ten times faster than LAN. You can add one or as many as 31 additional users per PC. Kimtron delivers the future now by allowing an ever-widening network of multi-user PC's.

The KT-7/PC may be complemented with one (or more) I/O Card, Memory Card, 8086 Speed

Enhancer Card, 80286 AT Card, 8088 Multi-Processor Card, 80186 Speed Enhancer Card, 68000 Card, and related software.

For more information about Kimtron's Multi-User Solution, or general video data terminals for other mini or micro multi-user systems, call your local computer dealers, distributors or Kimtron Corporation Today!

**(408) 727-1510**

NOTE: IBM PC, XT, AT, PC DOS, MS DOS, UNIX, XENIX, CPM 86, Multi-Link, Concurrent PC DOS are registered trademarks of IBM Corporation, Microsoft Corp., Bell Labs., Digital Research Inc., Software Link Inc. respectively.

Inquiry 218

1705 Junction Court  
Building #160  
San Jose, CA 95131  
**Kimtron**

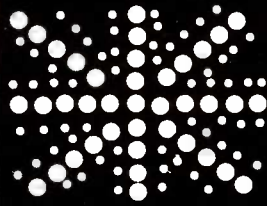

## New Database Ideas

### Frame theory used in a database generator

BY DICK POUNTAIN

All the research done so far in artificial intelligence (AI) points to the conclusion that if computers are to even begin to approach the capabilities of the human brain, they must store and retrieve huge amounts of context data. In humans this data appears to be a combination of innate and learned knowledge.

No one seriously suggests any longer that an intelligent computer can be realized purely algorithmically. Rather, the process will be a long and painstaking one that involves stuffing more and more facts into a machine. Some of these will be facts about the world we live in, while others will be rules about those facts. In short, the emphasis will be at least as much on smart data storage and retrieval as it is on computation and calculation.

These ruminations are prompted by a recent encounter with I.D.E.A.S. (Inference Driven Evolutionary Applications Software) from AI Software Ltd., a commercial database-generator package that uses a novel approach influenced by Marvin Minsky's theory of frames. It runs on mainframes, minicomputers, and microcomputers such as the Sage IV and the TDI Pinnacle. You can use it to create accounting, payroll, costing, stock control, and other commercial applications that use a shared database.

#### FRAMES

In the article "Database Types" by Rich Krajewski (October 1984 BYTE, page 137) there is a summary of six main categories of existing database software. Here's a recap of the three main types: A simple *file-management system* enables you to build files out of records. Records are self-contained parcels of data structured into fields that are the same for every record. In an address-book application each record would contain a complete name and address, with fields called Name, Street, City, and Phone Number, for example. However, information held in different files is totally separated and can't be related.

At a higher level of sophistication are the *relational* and *hierarchical* types. In a relational database, you can relate records from different files assuming that they have at least one field in common. If you have one file of customer names and addresses and another file with their names and credit balances, you can combine the information using Name as the common field and extract records containing name, address, and credit balance for a particular person. In other words, the links between different sets of data are made via the contents of the files, and you can define new relations while you're using the database by using the command JOIN.

In a hierarchical database, you can predefine a tree-like structure of relationships between different files that doesn't depend at all on the record contents. For instance, a file called Customers could own subfiles called Address and Credit Balance. A more complex form of this database allows any file to own any other, so the result looks more like a network than a simple tree.

The I.D.E.A.S. program doesn't fit comfortably into any of these categories. Data is related neither by the contents of data fields nor by a predefined file structure, but by a system of coordinates abstracted from the structure of the real world.

I.D.E.A.S. was conceived about five years ago by a group of commercial programmers who happened upon Minsky's 1974 paper "A Framework for Representing Knowledge," dealing with the AI problem of computer vision. Impressed by the methods expounded there, the group decided to try to set up such a framework for the world of commerce and manufacturing.

In a nutshell, Minsky's *frame* is a data structure for representing a state of affairs or an activity. The frame has *slots* that are filled with specific instances, while the frame itself represents the archetypal state. For example, a frame describing a house might have

(continued)

Dick Pountain is a technical author and software consultant living in London, England. He can be contacted do BYTE, POB 372, Hancock, NH 03449.



**Table 1: The prime dimensions used by I.D.E.A.S. to distinguish one piece of data from another.**

- 1) Time. A date or time of day.
- 2) Financial. A relationship to the accounting system.
- 3) External trading. A relationship with someone or something *outside* the enterprise.
- 4) Batch identity. An identifier for a particular batch of products.
- 5) Commodity. An identifier of a particular product type.
- 6) Internal organization. An identifier of a particular department or other subgroup *inside* the enterprise.
- 7) Personnel. The people involved.

slots called Living Room, Bathroom, Kitchen, Garage, etc. The contents of these slots might also be frames; the Kitchen frame could have slots Stove, Sink, Waste Disposal, and Freezer. To describe a particular house you fill in these slots with specific makes of appliances and furniture. Equally important, slots can have default values, so partial descriptions can be allowed and reasonable guesses made in the

absence of complete information. Groups of frames can share slots, thus relating different classes of objects (as in the relational database); as an example, an Office frame might share the slots Table and Chair with the House frame.

**PRIME DIMENSIONS**

The authors of I.D.E.A.S. studied their previous accounting, stock control,

payroll, and other programs to see if they could create a frame that would describe all the various kinds of data used. Through trial and error they identified a set of seven *dimensions* that they claim effectively define any piece of data used in a commercial/manufacturing enterprise. *Define* in this sense means that a set (between one and seven) of these types (or dimensions) is sufficient to distinguish one piece of data from another. The prime dimensions are shown in table 1.

To see how this works let's look at some examples. You can uniquely define a product's list price using only the commodity dimension (the product code). However, if you have different price lists for different kinds of customers, you need to specify both the external and the commodity dimensions (customer name or code and product number). If prices change

*(continued)*

**Greywolf MARKETING**

203-928-3654  
or 928-6555

**NEW Computers with**  
WORDSTAR ◦ MAILMERGE  
SPELLSTAR ◦ CALCSTAR  
INFOSTAR ◦ BASIC

**MBC 1200 \$799**

**8-Bit Integrated Computer with High-Resolution Display**

Two Z-80A CPUs (main and secondary) with no-wait mode and large 64KB RAM/4KB ROM memory capacity for fast execution.

High-resolution 640 x 400-dot matrix display with full graphics functions.

Choice of 33-line or 40-line text mode

CP/M operating system with editor, assembler and all standard utilities.

Easy-to-use Sanyo Graphic BASIC

One (MBC 1200) or two (MBC 1250) internal double-sided, double-density, double-track, 5 1/4" slim-type mini floppy disk drives with 640KB formatted

**CAPACITY**

Specially-designed detachable keyboard with coiled cable for easier operation

Interfaces for one Centronics printer and one RS-232 port.

**\*CASH PRICE ONLY\***

Check in advance. Add 3% for VISA/MC. No Returns. Shipping & Handling charges will be added to each order.

For complete technical literature send \$1<sup>00</sup> to:  
P.O. Box 889 PHONE ORDERS ONLY:  
Putnam, CT 06280 203-928-3654

**SUPER SYSTEM  
800-2**

**for Sanyo MBC 550**

Will Run The Sanyo Video Board

**\$1395.00 Complete**

**Software Features:**

- 100% disk compatibility across MS-DOS and PC-DOS, including ability to read, write and format disks from many computers including the IBM PC, the DEC Rainbow, and Tandy 2000
- Built-in RAM disk program offering disk access which is hundreds of times faster than floppies
- SortDir program to alphabetize and sort the large directories that these drives can hold
- ASCII Screen Dump program
- Calendar Program, a personal datebook which displays a two-month calendar on the screen
- Certificate to purchase a top-selling data base, Personal Pearl, for only \$99.95, a savings of \$200.00. Personal Pearl is a product of Pearlsoft, Inc.

**PLUS FREE**

Clock/Calendar Board  
(\$139.95 Value)

**Plus Free**

Video Display Monitor  
(\$125.00 Value)

**Plus Free**

256K of Memory  
(\$120 Value)

**Hardware Features:**

Operates as a standard 555-2 with two 360K drives

Flip a switch and run your Super Sanyo System with dual 811K drives

Works with Sanyo's New Video Graphics Board

Runs both MS-DOS 1.25 and MS-DOS 2.11 operating systems

Runs copy protected software, such as Michtron's Demon Seed and Cash Man

Clock/Calendar Board

**Sanyo Software:**

Wordstar, Easywriter, Calcstar, Sanyo Basic, MS-DOS 1.25, MS-DOS 2.11

EasyPac or StarPac (optional)

# SuperSoft Languages When Performance Counts

A programmer's most important software tool is the language compiler or interpreter he uses. He has to depend on it to work and work well.

At SuperSoft, we believe it. That's why we offer three excellent compilers: SuperSoft FORTRAN, SuperSoft C, and SuperSoft BASIC. They answer the programmer's need for rock solid, dependable performance on microcomputers.

## SuperSoft FORTRAN

**With large code and data.** SuperSoft FORTRAN version 2.0 with large code and data space is now available under MS DOS and PC DOS. It gives you the power to compile extremely large FORTRAN programs on micros. It allows double precision and complex numbers, full IEEE floating point, and a full range of other important features for the serious FORTRAN programmer. Both 8087 support and a RATFOR pre-processor are optionally available. FORTRAN (CP/M-80 & 86, MS DOS, PC DOS): \$325  
8087 support: \$50 RATFOR: \$100

## SuperSoft A

**A true Ada\* subset**  
SuperSoft A is a completely standard subset of the Ada language, incorporating approximately 63% of the standard Ada syntax and including such important features as packages and separate compilation. For CP/M-80 microcomputers: \$300.

## SuperSoft C

SuperSoft C is a high-powered, full-featured C compiler designed for serious C applications. It is fast – both in compilation and execution, and it is packed with more than 135 library functions (all delivered in source code form). SuperSoft C produces optimized assembly code, and object code can be ROMed.

SuperSoft C (for CP/M-80, CP/M-86, MS DOS, PC DOS): \$350



## SuperSoft BASIC

The SuperSoft BASIC compiler lets you get serious with business and financial programs. It uses BCD math to give you highly accurate results for demanding applications. SuperSoft BASIC is a true native code compiler that is generally compatible with Microsoft's BASIC interpreter. And an additional bonus – no run time license fee is required.

SuperSoft BASIC Compiler (for MS DOS, PC DOS, and CP/M-86): \$300

Also available for programmers:

Star-Edit, a full-featured programmer's text editor: \$225.00  
Disk-Edit, an invaluable programmer's disk data editor: \$100.00

To order call: **800-762-6629**

In Illinois call 217-359-2112

In conjunction with SuperSoft, SuperSoft FORTRAN was developed by Small Systems Services, Urbana, IL, a leader in FORTRAN development.

Japanese Distributor: ASR Corporation International, TBL Building, 7th Floor, 1-19-9 Toranomon, Minato-Ku, Tokyo 105, Japan Tel. 03-5025550. Telex 222-5650 ASRTYO J.

\*Ada is a trademark of the Department of Defense  
PC DOS is a trademark of International Business Machines.  
MS DOS is a trademark of Microsoft.  
CP/M-80 and CP/M-86 are trademarks of Digital Research, Inc.

# SuperSoft

SuperSoft, Inc., 1713 S. Neil St.,  
P.O. Box 1628, Champaign, IL 61820



frequently, you might want to date price lists, adding the time dimension, too.

Take another example. The value of an item dispatched could involve the external (who is the customer?), financial (how is it accounted for?), commodity (what product?), batch id (what order number?), and time (what

is the date of dispatch?) dimensions. In a large company the department (internal) could be relevant, too.

Prime elements are those data elements for which only one dimension is relevant (e.g., a customer code, a product code). They behave more or less like keys in a conventional database, but they are special

because you can organize them into hierarchical sets. For example, Customer codes can be made a subset of County codes, which are themselves a subset of Region codes. So Fred Bloggs can be situated in Yorkshire, which is situated in Northern England. More than one superset can also exist; Customer code can come under Industry code as well, allowing Fred Bloggs to belong in Heavy Chemicals.

When you create a new data element (e.g., Value of Item) in the I.D.E.A.S. data dictionary, you must fill in a primitive frame that identifies which prime dimensions are relevant for this element. In addition you must specify whether the dimension is fixed—constant data that goes into the dictionary—or floating—data provided at run time. For instance, the name of the department that makes widgets is fixed (unless there's a major company reorganization), but the customer's name is floating (you want to search for customers at run time).

Once you define such a frame, then I.D.E.A.S. knows where to store that type of item. In other words, you can represent every different kind of data object by a point in seven-dimensional space, or if you prefer, you can map individual records into eight-dimensional space—the eighth being an implicit record number. In physical terms, I.D.E.A.S. uses a multitude of single-key indexed-sequential files to represent this multidimensional space, but these files are completely hidden; indeed, the concept of a filename doesn't exist in I.D.E.A.S. The advantage of this sort of organization is that relationships between data items follow automatically; only data items that share *at least* one prime dimension can be related at all, and the relationship is forged as soon as the items are defined.

When the database is in use, the slots in the frames are filled with real instances of customer names, product numbers, etc., just as the fields of a record would be in a more conventional database.

This approach seems to me to have

*(continued)*

or

FEDERAL 1040 (REGULAR 256K)\$35		
1040	D	SE(S)
A	G	W
B	SE	6251
Plus worksheets for wages, IRAs, Soc. Sec. & EIC.		

FEDERAL 1040 (PRO 320K)\$95						
1040	C	F	SE	2106	3468	4797
A	D	G	SE(S)	2210	3903	4952
B	E	R	W	2441	4562	5695
						6251
C,F & 4562 are standalone for multiples						
Automatic supporting statements for Sched. A						

*"Nothing I have ever seen is so powerful, so fast, and so easy. \$95 is too little."* - Many, many CPA's

Taxtime is a highly integrated tax preparation program for use as a template with Lotus 123 and Symphony. It takes only 10 seconds to recalculate all forms, is easy to use, and is IRS approved. Federal 1040 and state forms are \$95.00, corporate returns are \$195, and annual updates are only \$45 to \$75. All programs require Lotus 123 version 1A and 256Kb or more memory. To order programs or free detailed catalog phone

800-227-2634 ext 998, or in Calif 800-772-2666 ext 998.



A product of Austin Scientific, Inc.  
1259 El Camino, Suite 260  
Menlo Park, CA 94025  
Dealer inquiries welcome.

123 and Symphony are trademarks of Lotus Development Corporation.



# TRANSTECTOR Has A Better Way To Eliminate Computer Malfunctions.

Computer foul-ups are enough to bring out the beast in even the most patient of individuals. But when random logic errors, memory loss, software damage or component failures have driven you to the brink, don't resort to wielding a sledgehammer. Fight back with TRANSTECTOR SYSTEMS.

TRANSTECTOR is the world's leading manufacturer of transient overvoltage protection systems for sensitive electronics. In fact, many FORTUNE 500 companies, such as NCR, General Electric Medical Systems and Johnson Controls, have chosen TRANSTECTOR to safeguard equipment they sell.

Now, that same famous technology is available to you. Ask your dealer for details on how TRANSTECTOR protectors can save you money--not to mention your mental health.

## TRANSTECTOR

10701 Airport Dr.  
Hayden Lake, ID 83835  
(208) 772-8515

For the name of the  
TRANSTECTOR SYSTEMS  
authorized dealer nearest you,  
call toll free:

**800-635-2537**

**FREE POSTER!**  
If you can empathize with the poor soul in this photo, you'll want an attractive, color poster (a \$7.50 value) to remind you that There Is a Better Way.  
Get your very own poster FREE with the purchase of any TRANSTECTOR protector from your local authorized TRANSTECTOR dealer.



tremendous virtues. The structure of the database is formed by factors relating to the real-world domain being dealt with, not by machine- or program-related constraints of the computer. Though I.D.E.A.S. was designed to reflect only the world of commerce and manufacturing, a different set of prime dimensions could

easily adapt the concept to another domain. In fact, if you study the I.D.E.A.S. prime dimensions carefully, you'll find that, renamed to be more general in scope, they apply rather well to other activities already. Could a computer scientist prove theorems about the number of dimensions needed for a given domain, or is that

to usurp the role of philosophy? How about a database manager called K.A.N.T.?

### PROCEDURE FRAMES

If you want to actually do something with the data stored in I.D.E.A.S., you must define some elements called *procedural frames*. They are equivalent to programs written in a command language but are produced by an integral program generator after an interactive question-and-answer session.

To produce, for example, an invoicing or stock-control system, you need a collection of data elements and a collection of procedural frames to work on those elements. Typical procedures might be Add Customer Orders or Update Stock Levels. The primitive operations available for use in procedural frames are all prefixed by a \$ sign and called \$commands. They include commands for formatting input and output screens, repetition and branching, conditionals and subroutine calls—in fact all the elements you'd expect to find in a database command language.

The most important \$commands are \$LOCATE and \$SCAN. These are the high-level instructions that actually traverse the complex network of database relationships and retrieve items for you. Let's say that we have defined a data element called Customer Order that requires a customer code (external), an order number (batch id), and a product code (commodity). If you give \$LOCATE those three constraints, it will find a unique order. If you give it only a product code, it will find the first order by any customer that includes this product, and \$SCAN will then retrieve all orders by all customers that include that product. \$LOCATE and \$SCAN issued without any constraints at all simply retrieve all customer orders.

\$LOCATE really emphasizes the power of the prime-dimensions concept. Since every piece of data *knows* how it relates to the others, you can do a lot with very little; if, for example, you use \$LOCATE to find a date, you can pull out everything that hap-

(continued)



**Screen Displays. Fast and Easy!**

Blaise Computing presents **VIEW MANAGER™**—a screen programming system for the IBM personal computer and hardware compatibles. **VIEW MANAGER™** speeds the creation, documentation, and incorporation of screens into programs developed in high level languages. Versions for C (Lattice, Microsoft, or Computer Innovations) and Pascal (IBM or Microsoft) are now available.

**VIEW MANAGER™** lets you create input/output screens by providing an integrated system of programs carefully constructed to make your screen development easy and fast. It features:

- ◆ Quick creation of new screens and editing of existing ones using an interactive painter efficiently storing screens in a screen database;
- ◆ Extensive control over the format of data written to and read from data capture fields;
- ◆ Ability to create on-line help files as part of the screen system;
- ◆ Automatic generation of screen documentation files, including details of formats for data entry fields, screen images, and names and sizes of all existing screens;
- ◆ A comprehensive library of routines to include in your programs allowing full manipulation of screens and the data that they display or capture;
- ◆ Royalty-free distribution of your commercial or in-house applications developed using **VIEW MANAGER™**.

All this adds up to a productivity tool no system developer in the C and Pascal environment should be without.

**\$275** (Source code available for routine library—an additional \$150)

---

**VIEW MANAGER™** is part of the Blaise Computing Productivity Series. Other products to speed your development projects in C and Pascal include:

**TOOLS™**—A library of routines for advanced string handling, forms utilities, screen handling or more \$125

**TOOLS 2™**—A library of routines for access to operating services of DOS 2.0+ from within your program—includes memory allocation, program chaining, file and buffer handling \$100

**EXEC™**—A program chaining dispatcher for all DOS-executable files supporting a common data area \$95

**BLAISE COMPUTING INC.**  
2034 Blake Street Berkeley, CA 94704  
(415) 540-5441

# DATAEASE™

*"I was very impressed  
with its overall performance  
and features... excellent interactive  
and data quality assurance capabilities  
... relatively easy to master..."*

**Bill Jacobson**  
From a feature article in  
**BYTE**, October 1984

Over 20,000 large and small business clients worldwide have turned to DATAEASE to increase productivity. In fact, leading software suppliers to Corporate America like MIS, Inc have recently sold more DATAEASE than dBASEIII®, Symphony™, Framework™ and R:BASE™ 4000!

DATAEASE, with its ideal combination of power and ease-of-use lets you harness the full power of your micro to create forms and custom menus; gather, sort, group and calculate statistical information, update and link files, generate standard or custom reports, interchange data with mainframes and popular programs.

DATAEASE, the complete information management system. Available through highly competent dealers throughout the U.S. Call or write for information on The SOFTEASE Family of Products™ DATAEASE, WORDEASE™, GRAPHEASE™, DOSEASE™.

## DATAEASE BYT-4/85

### Demonstration Diskette

- Check one:  IBM PC  WANG  DEC  TI  
 Check attached for \$10. Send information package with demonstration.  
 Send information only.

Name: \_\_\_\_\_

Title: \_\_\_\_\_ Phone: \_\_\_\_\_

Company: \_\_\_\_\_

Street: \_\_\_\_\_

City: \_\_\_\_\_ State: \_\_\_\_\_ Zip: \_\_\_\_\_

**Software Solutions, Inc., 305 Bic Drive  
Milford, CT 06460 • 203-877-9268 • Telex: 703972**

**For dealer, corporate and product information call:**

**800-243-5123**

Scandinavia  
West Soft A/S, Alesund, Norway; (47) 71-41141

South Africa  
Dataflex, Craighill; 11724-6353

United Kingdom  
Sapphire Systems, Essex; 01-544-0582

West Germany  
Markt & Technik, Munich; 089-4613-0



pened on that day. An Order system with *parts explosion* is merely a matter of a couple of \$LOCATE and \$SCAN commands in a loop.

The \$NEWLVL and \$OLDLVL commands allow you to move up and down between children and parents in a hierarchical set. \$CALL allows one procedure to call another, and control returns automatically when the called procedure finishes. Calls can be nested in up to nine levels. And calculation is possible in a procedure, although it's currently restricted to four-function arithmetic on 11-digit floating-point numbers.

Since I.D.E.A.S. is an interactive system, you can create new procedures at any time, or modify existing ones, without necessarily altering any data element definitions at all. This makes testing and maintenance a fairly straightforward proposition. Built-in utilities provide cross-referencing of both procedure calls and data-element references by procedures.

### THE I.D.E.A.S. SYSTEM

I tested I.D.E.A.S. running on a TDI Pinnacle microcomputer with a Wyse WY-50 terminal. This new machine is similar in many ways to the Sage IV—it's a single-box 68000-based machine with 512K bytes of memory, one 800K-byte floppy-disk drive, and a 21-megabyte Winchester. It runs its 68000 at 12 MHz with no wait states and is normally supplied with a multi-user version of the UCSD p-System and on-board support for up to seven

terminals. It's like having a mainframe on your desk, which is just as well since I.D.E.A.S. was born on a mainframe and needs plenty of memory and disk space. The version I tested runs under the alternative multiuser BOS (basic operating system) and is written in RM COBOL. You can port it to any operating system that compiles RM COBOL, which includes MS-DOS and CP/M.

The system consists of three modules, the data dictionary, solution generator, and run-time interpreter, all of which are menu-driven. These modules are entered from a main menu so you never need to exit to the operating system.

In the dictionary you create new data elements or inspect existing ones. When you enter a new name, the system presents you with a blank frame, dimension by dimension, to fill in with float, fix, or irrelevant. And you can list all the elements that use a particular combination of prime dimensions with a menu selection called *frame analysis*. When searching for existing data elements in the dictionary, you can type part of a name and the system will show you all the entries containing that part.

Data names can consist of up to 20 characters (including spaces), which allows you to use readable English. You may also have several names for one object (aliases) so different departments can employ their own uses; for example, the machine shop and the accounting department might

have different terms for talking about batches. The system keeps track of such aliases and prevents them from clashing with the names or aliases of other data items.

You can define a data item as numeric, text, or date type, and you can give it a class. The classes are Journal, Ledger, Property, and Transaction, and they determine what you can do to such an item. For instance, if you declare an item as Journal class then you can never delete or alter it, but you can annul it by a later entry, thus preserving a coherent audit trail. You can add to or subtract from Ledger entries but you cannot overwrite them. Properties are ordinary data items with no use restrictions.

In the generator you create procedural frames by first naming them and then roughing them out in the form of comments using an integral editor. When given the generate command, the generator goes through this script, line by line, asking for the details of the \$commands and their parameters, labels, jump destinations, and so on. When this is done, it generates the code.

The run-time module is the interpreter from which you use an I.D.E.A.S. application. You run procedures by typing in their names.

I'd like to report that the implementation is as advanced as the principle upon which it's based, but it's not. The program betrays its mainframe origins in a user interface that is decidedly unfriendly by the standards of

## THE \$2395 DEVELOPMENT SYSTEM

Turns any personal computer into a complete micro-computer DEVELOPMENT SYSTEM. Our integrated control/display program runs under MS-DOS, CP/M, ISIS, or Apple and controls the UDL via an RS-232 port.



Up to 128K bytes of EMULATION ROM (8K standard) allows you to make program patches instantly. Since the target ROM socket connects data and address lines to both the analyzer and the emulator, no expensive adaptors or personality modules are needed.

The powerful BUS STATE ANALYZER features four-step sequential triggering, selective trace, and pass and delay counters. Symbolic trace disassemblers and debuggers are available for Z-80, 8048, 6500, 6800, 8031, 8085, Z-8, 1802, 8088/80188, 8086/80186, R65 and 68000.

PROM PROGRAMMER also doubles as a STIMULUS GENERATOR.

For further information, call or write:  
**ORION** Instruments  
 702 Marshall St., Suite 614  
 Redwood City, CA 94064  
**(415) 361-8883**

modern microcomputer software.

In addition to trivial but irritating details like its refusal to accept menu selections in lowercase, I.D.E.A.S. is designed around a Teletypewriter-style terminal, with a crude line editor for procedural frame construction and no support for modern terminal facilities like cursor addressing or screen highlighting. Much of this is probably due to COBOL's limitations.

The difficulties I had using the program had more to do with this spartan user interface than with the system's underlying concepts. On-line help is minimal and the menus tend to be phrased in I.D.E.A.S. jargon, which is less than clear to a first-time user. And the documentation had few examples, although it is being revised.

There are also some gaps in the specification at the moment, most notably in the area of sorting. There is no provision for lexical or numeric sorting in the procedure generation module. This is not as big a problem as it might appear because I.D.E.A.S. holds and retrieves data already sorted on the prime dimensions. However, it would be better if you could override this with an explicitly requested order in some cases.

I should point out that AI Software doesn't consider I.D.E.A.S. static and is working on a variety of extensions, including a query language (independent of the procedures) and a graphics module. A rewrite (in C) for UNIX systems is also planned; this should provide an opportunity to polish the user interface a little. It is important to note that I.D.E.A.S. is being sold as a tool for systems houses to produce applications for sale on a license basis. It was never intended as an end-user system.

### CONCLUSIONS

The concept underlying I.D.E.A.S. seems to me to be a fruitful one. The notion of using dimensions abstracted from the problem domain to structure a database, rather than relationships suggested by the form of data representation (often chosen more by the computer than the user), seems very much in line with the new directions

being explored in declarative programming languages.

It would be very interesting to see how well the I.D.E.A.S. concept would translate into Prolog; I suspect that it would go rather simply, since equivalents of \$LOCATE and \$SCAN are built-in functions of Prolog. I doubt, however, that Prolog is sufficiently

known or accepted yet in commercial programming circles for such an experiment to be attractive. ■

FOR MORE INFORMATION

I.D.E.A.S.  
AI Software Ltd.  
Park Lorne  
111 Park Rd.  
London NW8, England

# VOLKSMODEM 12. PORSCHE PERFORMANCE, VOLKSMODEM PRICE.



**\$299.**

Who says basic transportation for data can't boast sports car performance? Compatible with virtually every personal computer on the market today, our VOLKSMODEM 12 is loaded with today's most desired performance features, and no sticker shock! Auto dial/auto answer. Hayes command structure. 300/1200 baud data rates. And more. With the Volksmodem

12 and one of seven adapter cables you are instantly in touch with the world of data communications.

How can we offer all this at a sticker price that makes the competition cringe? Because we're Anchor Automation, one of the world's leading independent modem makers.

Visit your local computer store, today! Kick the tires. Look under the hood. Compare what you pay with what you get. You'll find the VOLKSMODEM 12 runs away from the pack.

Anchor Automation, Inc., 6913 Valjean Ave., Van Nuys, CA 91406. (818) 997-7758

**ANCHOR AUTOMATION**  
A Leader in Modem Technology

© 1984 Anchor Automation, Inc.





**"JUST WHEN I GET  
A GREAT IDEA,  
THE DICTATING MACHINE  
BREAKS!"**





# SEE LANIER.

The Lanier Pocket Caddy II.<sup>®</sup> Lightweight. Rugged. Reliable. It works where you work. And it's backed by service second to none. High technology? Absolutely. Lanier is now part of Harris Corporation, a world leader in Information Technology. Call us at 800-241-1706.<sup>\*</sup> Or send the coupon. Today.

**FOR YOUR INFORMATION,  
WE'RE NOW PART OF HARRIS.**

<sup>\*</sup>In Georgia call (404) 321-1244 collect.

Lanier, A Harris Company—Thought Processing Division  
For more information on the Lanier Pocket Caddy II<sup>™</sup>, circle # 219.

Thought Processing Division  
1700 Chantilly Drive, N.E.  
Atlanta, GA 30324

**LANIER**  
A Harris Company

Name \_\_\_\_\_

Firm \_\_\_\_\_ Title \_\_\_\_\_

Address \_\_\_\_\_

County \_\_\_\_\_ Phone \_\_\_\_\_

City \_\_\_\_\_ State \_\_\_\_\_ Zip \_\_\_\_\_

**HARRIS**

Mar '85 Byte 175BC5





## Why people choose an IBM PC in the first place is why people want IBM service...in the first place.

After all, who knows your IBM Personal Computer better than we do?

That's why we offer an IBM maintenance agreement for every member of the Personal Computer family. It's just another example of blue chip service from IBM.

An IBM maintenance agreement for your PC components comes with the choice of service plan that's best for you—at the price that's best for you.

Many customers enjoy the convenience and low cost of our carry-in service. That's where we exchange a PC display, for example, at any of our Service/Exchange Centers.

And for those customers who prefer it, we offer IBM on-site service, where a service representative comes when you call.

No matter which you choose for your PC, an IBM maintenance agreement offers you fast, effective service.

Quality. Speed. Commitment. That's why an IBM maintenance agreement means blue chip service. To find out more about the specific service offerings available for your PC, call 1 800 IBM-2468, Ext. 104 and ask for PC Maintenance.

Inquiry 193

Blue chip service from **IBM**



バイト

B·Y·T·E J·A·P·A·N

## The Fifth Generation in Japan

ICOT  
The Hitachi S-810  
supercomputer  
Software  
development

BY WILLIAM M. RAIKE

**T**he International Conference on Fifth Generation Computer Systems was held in Tokyo in early November 1984. Over 900 participants, representing 32 countries, each paid about \$400 for the privilege of attending. Researchers from all over the world presented 62 research papers, and there were a couple of interesting panel discussions in addition to a highly informative nontechnical lecture by Ezra Vogel ("The Changing Nature of Information Societies").

The objectives of the conference were twofold: to provide an international forum for the exchange of information, ideas, and research in areas related to "new-generation computing," and to present to the world a summary of the achievements of the Japanese government-sponsored Institute for New Generation Computer Technology (ICOT) at the end of the first of its three phases. The second phase of the 10-year project will last four years and the third phase, three years.

To gain perspective on what the Japanese have thus far accomplished in their fifth-generation efforts, you first have to look at the objectives for the project. Note that the buzzwords "fifth-generation computing" and "new-generation computing" are recent additions to computer jargon; they're catch-all terms that include such topics as parallel computer-hardware architectures, artificial intelligence, so-called "expert systems," and "logic programming"—a term used to refer to programming languages such as Prolog.

Started by the Ministry of International Trade and Industry three years ago, ICOT is headed by soft-spoken but intense Dr. Kazuhiro Fuchi. He provides something of a bridge between ICOT's highly technically oriented people, who live in abstract worlds of "parallel data-flow architectures" and "OR-parallel functions of the KLI kernel language," and the bureaucrats in the Ministry who fund ICOT's research.

Members of the Ministry support such general objectives as giving computers a

more direct role in "improving management decision making" as opposed to "mere data processing," providing more "user-friendly interfaces" (including natural-language processing), and "automating software development," etc. They stress the importance of office automation (word processing, filing, etc.), in which Japan lags behind the U.S. by several years (despite its first-class, inexpensive hardware), and would like to see applications of computers in the medical field, which are nearly unheard of here in Japan. These worthy objectives are not tied exclusively to the Fifth Generation Project, but it is important to note that they have been pursued actively outside Japan for years (and not just by computer scientists). Operations-research specialists and "quantitative-management" people were emphasizing these themes as far back as the 1960s. The Japanese computer industry seems remarkably oblivious to the progress that's been made in such areas, principally in software, over the last 15 years; I'll say more about this observation later.

Dr. Fuchi's views on the priorities of ICOT are more illustrative of what is actually going on at the Institute. He insists that the Fifth Generation Project is not intended to produce commercial benefits—a claim that is met with skepticism by just about everyone. In his opinion, ICOT's focus is on basic technological research and development over the long range—10 to 20 years. He doesn't deny that individual companies might spin off segments of the technology before then, but he disavows that as a goal. He says that ICOT has "no intention of getting involved in the artificial-intelligence business," although ICOT's close relationship to AI and expert systems is clearly the basis for the choice of a language like Prolog, a so-called "logic programming" language, as the point of departure for the "kernel language" of the Fifth Generation Project.

The kernel language, which is not supposed to be viewed as a user language, pro-

(continued)

*William M. Raikes, who holds a Ph.D. in applied mathematics from Northwestern University, has taught operations research and computer science in Austin, Texas, and Monterey, California. He holds a patent on a voice scrambler and was formerly an officer of Cryptext Corporation in the United States. In 1980, he went to Japan looking for 64K-bit RAMs. He has been there ever since as a technical translator and a software developer.*



vides both the theoretical and practical interface between the fifth-generation hardware and software. For the first of ICOT's three phases, the kernel language (called KLO) is implemented as a macro language called ESP (extended self-contained Prolog). On one hand, it provides a specific machine language used to define the capabilities of specific fifth-generation hardware. On the other hand, ESP, best described as a macro assembly language for KLO, has been used to write the operating system for the "sequential inference machines" (dubbed PSI machines, for "personal sequential inference machines") that the ICOT researchers will use as basic building blocks to experiment with parallel machine architectures during the second phase of the project. The operating system, called SIMPOS (sequential inference machine programming and operating system), is still in-

complete, although enough exists to provide a practical demonstration and research tool.

Interestingly enough, although the PSI machines (six of them exist now, and another dozen or so are scheduled to be completed) are also intended to be used as primary software-development tools for the parallel inference machine (which will be the focus of ICOT's second phase), software development to date has been done on a DEC 2060 and assorted VAX-11 machines.

Dr. Fuchi is concerned about widespread misunderstanding of the role of Prolog (versus LISP) as the basis for the kernel language; he emphasizes that the concept of a kernel language is distinct from that of a user language, and that, while he feels the decision to go with Prolog has been justified by the first-phase results, there is no need to view that choice

as static. In fact, one of the outcomes of the research so far has been to point out areas in which Prolog needs to be extended and modified. ESP is one of the results of that process. When I asked Dr. Fuchi whether he felt ICOT's commitment to Prolog-like languages might have been too narrow and whether there would be any changes in that commitment in the future, he replied that, if anything, there would be an expanded effort in that direction. The kernel language for the "parallel inference machine" under development in the second and third phases of ICOT is called KLI; it's going to be based on Concurrent Prolog.

It's never easy to evaluate the results of basic research and development projects. By the time the dust settles, it's hard to remember what was new, what was useful, and what just

(continued)

# SATISFY YOUR DRIVES!

## 70 MAIN/FRAMES & DISK ENCLOSURES FROM \$100



**800D2F**  
5" Floppy Main/Frame  
(10 cards) **\$392**

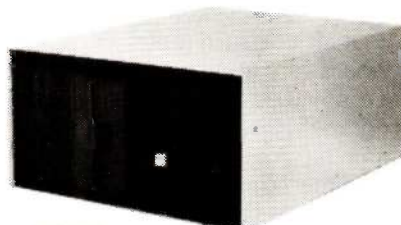

**2215**  
5" Floppy Winchester  
Main/Frame (7 cards)

**\$380**



**2905**  
5" Disk Enclosure **\$100**



Write or call for our brochure which includes our application note: "Making micros, better than any ol' box computer"

**INTEGRAND**

8620 Roosevelt Ave./Visalia, CA 93291  
209/651-1203

We accept BankAmericard/Visa and MasterCard



# CASHCOM

## Stand Alone or Multi-User POINT OF SALE SYSTEMS



### IBM PC/XT CAN FUNCTION AS THE SYSTEM'S MASTER

#### AS A COMPUTER

The stand alone system can be upgraded into a multi-user system to meet growing business needs.

Uses CP/M or MS-DOS (multi-user system only) to run thousands of dedicated software packages available to users.

Displays transactions on a 9" CRT utilizing large characters for easy customer viewing.

Utilizes two way data communications allowing quick and accurate price changes, order processing and file updates.

Can be programmed using familiar languages for easy customization of vertical markets.

Utilizes a database management system to produce meaningful reports on demand.

Can be configured with floppies or Winchester drives (storage capacity-640KB to 80MB).

#### AS A CASH REGISTER

• Its flexibility in function use exceeds industry standards for E.C.R.'s.

• Uses a programmable, buffered keyboard.

#### IT IS CAPABLE OF:

- error correct, void, return, refund, entire ticket voiding, manual discount by \$ or %, mark down, mark up, coupons, food stamps.
- payment by cash, cheques or credit cards.
- charge and payment posting to in-house accounts.
- H.A.L.O./L.A.L.O. protect on open departments and discounts.
- black list and credit authorization.
- electronic funds transfer.



**Advanced  
Business  
Computer  
Systems International, Inc.**

In Canada:  
4088 Sandwich Street, Windsor, Ontario N9C 1C4 (519) 255-9199  
In U.S.A.:  
P.O. Box 32524, Detroit, Michigan 48232 (313) 961-3406  
Inquiry 11



## Back, by popular demand.

Just a few years ago, illegal hunting and encroaching civilization had all but destroyed the alligator population in the south. They were added to the official list of endangered species in the United States.

Now alligators have made a comeback.

Conservationists intent on preserving this legendary reptile helped the alligator get back on its feet. Once again some southern swamps and marshes are teeming with alligators.

With wise conservation policies, other endangered species have also made comebacks . . . the cougar, gray whale, Pacific walrus, wood duck, to name a few.

If you want to help save our endangered species, join the National Wildlife Federation,



Department 106, 1412  
16th Street, NW,  
Washington, DC  
20036.

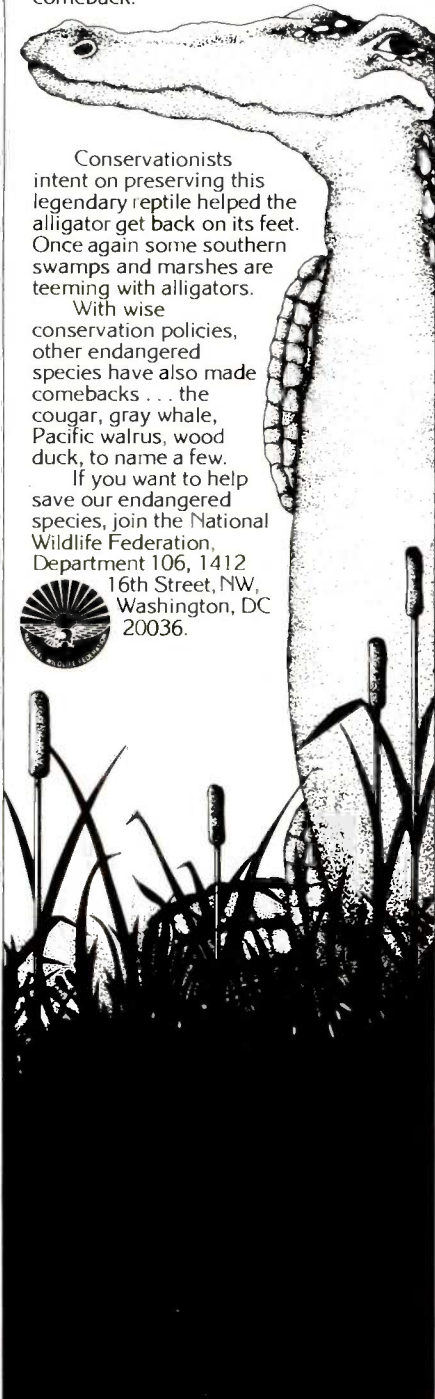

didn't work. I can see two notable successes, though, for the first phase of ICOT's efforts. No matter where the research goes from here, it's plain that a lot of new hardware, a new operating system, and some demonstration applications are up and running together, all based on logic programming. Even though the demonstrations seemed a bit lame to me—mostly rehashed versions of various puzzles, textbook problems, and very-small-scale expert systems—no one can say "It'll never get off the ground." The other success, easy to overlook, is that Japan, often criticized for copying, adapting, and perfecting existing technology instead of starting something of its own, has made the world sit up and take notice of the fifth-generation project. Efforts like the European Economic Community's ESPRIT (European Strategic Program for Research in Information Technologies) project, Great Britain's Alvey project, and projects in West Germany and France, not to mention the defense-oriented U.S. Strategic Computing program, have all been undertaken and funded in response to the Japanese initiative.

Another remarkable aspect of the Japanese program is that it's being done in the open, accessible to the rest of the world. With the exception of the U.S., all of the representatives of the various international fifth-generation computing projects urged greater international research cooperation. (The U.S. has strongly oriented its efforts toward goals framed in terms of its national security, and even the budget figures since 1982 are not in the public domain.) Whether this cooperation will amount to anything remains to be seen: the U.S.'s David Brandin, former president of the Association for Computing Machinery, quipped: "Everyone's talking about it, but they all want the other guy to go first." Be that as it may, the Japanese, simply by having held this conference, have set an example of openness that deserves to be imitated.

During the week following the conference, ICOT held an open house for

participants at its headquarters in Mita, in central Tokyo. The atmosphere at the open house was much less formal than the conference sessions. We were able to ask the ICOT staff about specific details in their specialties, although we had a few language problems because of the low skill level of the Japanese-English interpreters who were available.

During the open house one of the demonstrations of the PSI machine revealed an interesting aspect of Japanese computerdom. This particular demonstration was intended to illustrate a limited English-language parsing (grammatical-analysis) system. Rather than using the keyboard to type in the sample sentence to be analyzed, the operator used a mouse to select individual words from among 30 or so choices that appeared on a menu. One of the reasons the Japanese are so interested in mice is that few of them ever learned to type—in English or Japanese—except for professional typists and the rapidly expanding ranks of word-processor operators.

Conference participants were also invited to participate in "technical visits" to the facilities of various computer and electronics manufacturers in and around Tokyo. A group of us visited the Hitachi Central Research Laboratory (located in the middle of several acres of beautiful woods near Kokubunji on the western fringe of the Tokyo megalopolis), where we got a close look at the Hitachi S-810 supercomputer.

In contrast to the Fifth Generation Project, the S-810 is Hitachi's entry in the commercial competition for the fastest very-large-scale scientific computer. The S-810 has a peak processing rate of over 600 megaflops (million floating-point arithmetic operations per second), somewhat faster than the U.S.'s mammoth Cray-1. It achieves its speed by using a "pipeline" architecture, in which certain operations can be carried out simultaneously on large volumes of data. The Central Research Laboratory uses the S-810 mainly for VLSI (very-large-

*(continued)*



# **MEDIA MATE™. NO OTHER DISKETTE FILE COMES UP TO ITS STANDARDS AND DOWN TO ITS PRICE.**



*Pick the Media Mate up by the self-latching handle, and take it with you.*

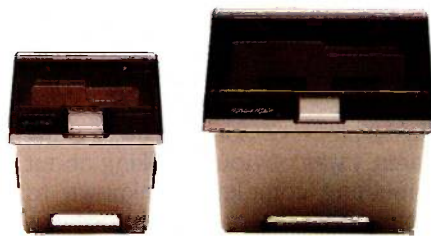

*Whether you use 3 1/2" or 5 1/4" diskettes, there's a Media Mate that's right for you.*

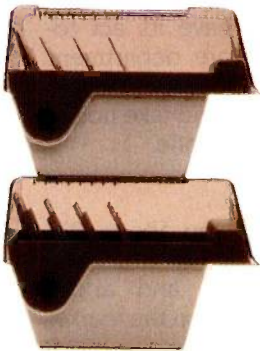

*Here's organization that really stacks up. And solid construction that keeps dust out.*



*These ridges keep the dividers in place and your disks in order.*

*The Media Mate stands firm, thanks to its non-skid feet.*



For organizing and protecting your diskettes, the Amaray Media Mate™ is the best file you can own. And you can buy it for just \$15.95.\*

So be sure you don't settle for less. Or pay more.

The Media Mate from Amaray. Available in two sizes to hold up to fifty 5 1/4" diskettes, or thirty 3 1/2" diskettes. Ask for it anywhere floppy disks are sold. Or call 800-4-AMARAY for the dealer nearest you. Amaray International Corporation, 14935 N.E. 95th Street, Redmond, WA 98052.

\*\$15.95 suggested retail price, Media Mate 5; \$14.95 suggested retail price, Media Mate 3.

**AMARAY**  
Makers of Media Mate

Inquiry 21





scale integration) circuit-design studies and for large-scale simulation studies in solid-state physics.

The software for the S-810, however, is pathetically unsophisticated. Other than assembly language, the only language available at the laboratory is FORTRAN. Now, I don't want to put down FORTRAN; it was the second computer language I ever learned (back in the days of FORTRAN II), and it is still one of the best tools around for handling complex numbers and other kinds of heavy-duty number crunching. And there are some fine optimizing compilers for FORTRAN (largely because of some of the main weaknesses of the language, like its lack of structure). But since the super-computer group is supposed to be on the leading edge of the push for improvement in software productivity, I asked the Hitachi researchers what kinds of software tools were used to

speed up program development and improve maintainability. I got blank stares. I then asked if they used something like a RATFOR (Rational FORTRAN) preprocessor. I got more blank stares. I was obviously talking about something completely unknown to them. RATFOR is a preprocessor whose use is essentially free; the source code appears, for example, in the book *Software Tools* by Brian W. Kernighan and P. J. Plauger, and the actual preprocessing is very fast, even on personal computers. The benefits, in terms of development speed and program maintainability and readability, are enormous. Even more to the point, such programs have been available and widely known in the U.S. and elsewhere for more than 10 years.

Despite the existence of what was supposed to be an "optimizing vectorizing" compiler that would produce machine code to take the best advan-

tage of the S-810's parallel architecture, the Hitachi research lab people admitted that if they simply ran the same FORTRAN code used previously on their M-280 mainframe, a fast but conventional computer, the super-computer was no faster! To gain any significant speed advantage from the S-810, they needed to manually "tweak" the code. The conclusion from this and other similar experiences: The Japanese computer industry doesn't yet have its act together in the software department and won't, unless a lot more people in the industry sit up and take notice of how to get things done.

#### COMING UP

Next month I'll tell you about IBM Japan's test production of 1-megabit dynamic RAM chips and about several new computers on the market here. ■

**The Most Affordable Disk Maker™**  
**NEW!** **in the Universe**  
 Now with over 25 MSDOS formats, 3½" formats, IBM PCAT and word processing format options

Disk Maker II shown with opt. drives

### Download fast, read over 200 formats easily, reformat rapidly

The more disk formats you work with, the more our Disk Maker™ system saves time and money by reading and/or writing disks in any of over 200 formats. No modems, no patches, no other special software necessary.

**Disk Maker II** is a complete, stand alone system with one 8" DSDD disk drive, one 48 tpi 5¼" DSDD disk drive, 6 MHz Z80B, 64K CP/M system with Disk Maker™ software. (96 tpi and second 8" drive optional.) Just plug in your terminal and make disks! Bundled software includes MicroShell™/MCALL-II communications software. Base price: \$3,395.

Supported with comprehensive, easy-to-read manual, software updates (\$50.00, all formats in revision), and additional drives and hard disk options.

**Disk Maker™**  
 prices from  
**\$1,695**

**Disk Maker I** runs as a peripheral with an S-100 system and comes with S-100 controller board, one 48 tpi DSDD 5¼" disk drive, dual drive cabinet and power supply, cables and Disk Maker software. 96 tpi and 8" drives are optional. Base price: \$1,695.

**NEW  
 GENERATION  
 SYSTEMS**

1800 Michael Faraday Drive, Suite 206, Reston, VA 22090  
 (703) 471-5596 Order Line: (800) 368-3359  
 Dealer inquiries welcomed.



# Fast Cash For Your Slow Modem.



## During Hayes Modem Trade-Up Days Now through April 30, 1985

If your old modem is costing you too much in time and telephone charges, now's the time to trade up to the industry leader—Hayes Smartmodem 1200™ (operates with the IBM® PC and many other personal computers, including Macintosh™) and Hayes Smartmodem 1200B™ (plug-in board modem for the IBM PC and compatibles).

**Cash saving rebate.\*** During Hayes Modem Trade-Up Days, bring in your old modem (any speed, any make) to a participating dealer. And Hayes will send you a cash rebate when you purchase a new Smartmodem 1200. If your used modem is a Hayes, we'll send you \$50; if it's some other brand, we'll send you \$25. It's that simple.

What's more, we've just reduced the price of Smartmodem 1200 and 1200B, so you'll actually save two ways!

**Get on-line with the leader.** Don't miss this special opportunity to dramatically increase the

speed and performance of your communications. While cashing in on some great savings from Hayes, the telecomputing leader.

**Call right away** for the name of your nearest participating dealer. And get fast cash for *your* slow modem.

**1-800-255-2550** (In the Continental U.S.).

(Call 1-800-447-0890 in Alaska and Hawaii).

Remember. Our modem trade-up offer is only good through April 30th.

So call today.

**Hayes**  
Innovative products  
for enterprising people

**Hayes Microcomputer Products, Inc.**  
5923 Peachtree Industrial Blvd.  
Norcross, Georgia 30092

\*The promotion is available only through participating dealers in the U.S. and Canada. Please allow 4 to 6 weeks delivery for rebate check. Smartmodem 1200 and Smartmodem 1200B are trademarks of Hayes Microcomputer Products, Inc. Macintosh is a trademark of Apple Computer, Inc. IBM is a trademark of International Business Machines Corp. ©1985 Hayes Microcomputer Products, Inc.



# C·I·R·C·U·I·T C·E·L·L·A·R F·E·E·D·B·A·C·K

Conducted by Steve Ciarcia

## STEVE ON MOVs

My Circuit Cellar article in the December 1983 BYTE, "Keep Power-Line Pollution Out of Your Computer," generated a large number of questions relating to various applications of metal-oxide varistors (MOVs). While letters I've answered in BYTE have addressed some of these specific questions, it seems worthwhile to present some additional information.

I chose the Radio Shack MOV because it was easily obtainable, but there are several other sources. The V130LA10A is manufactured by General Electric and should be available from any local GE parts distributor or electronic parts supply house. In addition, General Instrument and Panasonic manufacture similar units. The equivalent Panasonic part number is ERZ-C14DK201 and is available from a local Panasonic stocking distributor or from

**DIGI-KEY CORPORATION**  
Highway 32 South  
POB 677  
Thief River Falls, MN 56701  
(800) 346-5144  
The part number is P7063.

The General Instrument equivalent, part number SI4K130, is available from

**ACTIVE ELECTRONICS**  
POB 8000  
Westborough, MA 01581  
(800) 343-0874

The V8ZA1 MOV shown in the article is designed for 5-volt DC circuits; the V130LA10A is designed for 130-volt AC circuits.

The maximum continuous AC or DC voltage rating of an MOV should be about 10 percent greater than the line or system voltage for which suppression is desired. A general rule is to select the lowest-value MOV that is equal to or greater than the maximum line voltage. For example, if the line voltage is 120 volts AC,  $120 \times 1.1 = 132$  volts, and a 130-volt MOV should be the value selected. This is true for line-to-line, as well as line-to-ground, applications. Remember, if a possibility exists that any line connections can be made backward, they will (Murphy's law), so consider this

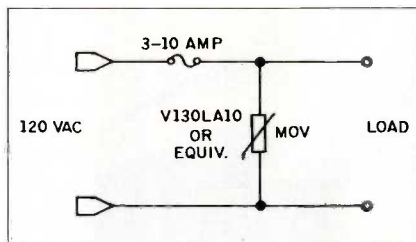

Figure 1: A fuse can help prevent a failed MOV from exploding.

in your selection. Also, the V130LA10A MOVs mentioned in my article can be used for the common mode clamping (line-to-ground) on a 220-volt AC line (providing that a polarized plug is used to ensure proper connections) but will be underrated for the differential mode clamping (line-to-line). A General Electric V250LA20A, or equivalent, is a suitable unit.

The energy rating for an MOV should be as high as practical and is often limited by physical space or economic considerations. When surges beyond their ratings are impressed, MOVs usually fail by short-circuiting. If there is no current-limiting protection, large amounts of energy are absorbed, and the MOV can explode. This potential hazard can be minimized by the addition of a fuse, as shown in figure 1, and physically shielding the MOV from surrounding circuits. The fuse should be placed to open the circuit when the device fails, so that loss of transient protection is known.

Devices that connect across the power line at the service entrance to reduce the amplitude of large transients and lightning surges are available. They are two-pole, three-wire units that are designed for 120/240-volt single-phase service and are designed to mount in a 1/2-inch knockout in the service entrance box or at the weatherhead. Such devices are available at local electrical supply houses and are in the \$20 range. They clip at voltages higher than the MOVs described in my article, so the MOVs should still be used. The General Electric Home Lightning Protector GE Thyrite 9L15BC002, Square D Model J9200-10, and Delta Lightning Arrestor (POB 1084, Big Spring, TX 79720,

(915) 267-5268) are suitable units.

All of the sockets on the power strip are in parallel, so it does not make any difference where the MOVs are placed. They can be placed across one socket or spread out for ease of assembly. Should a transient appear on the line, the MOVs will clamp it to a safe level. The important thing is to keep the lead length short so that the clamping voltage is not compromised.

If your power strip contains a line filter, it is desirable to place the MOVs downstream (equipment side) of the filter. The filter will attenuate some transients and may possibly extend the life of the MOV. Several companies manufacture power-line filters that are suitable for such applications. They include

**CORCOM INC.**  
1600 Winchester Rd.  
Libertyville, IL 60048  
(312) 680-7400  
Type 5VK1 or 5VK3

**CORNELL-DUBILIER ELECTRONICS**  
150 Avenue L  
Newark, NJ 07105  
(201) 589-7500  
Type APF511L

**DELTA ELECTRONIC INDUSTRY USA**  
1355 Yosemite Way  
Hayward, CA 94545  
(415) 785-5231  
Type 05DBAG5

**POTTER COMPANY**  
POB 337  
Wesson, MS 39191  
(601) 643-2215  
Type 600A5

These filters are equivalent to the Radio Shack part number 273-100 listed in my article, which is no longer being stocked. Write the manufacturers for additional information and the address of your nearest supplier.—Steve

## TELEPHONE-LINE PROTECTION

Dear Steve,

I enjoyed your article on the musical telephone bell greatly (July 1984). It's a

(continued)





*Equipping a PC for business takes a hard disk. Turn to **SYSGEN™** when you want the best.*

*Smart disk users insist on tape for data file back-up. **SYSGEN** is the leader.*

*And, if your needs begin to exceed the limits of PC memory and slot expansion, **SYSGEN** has the solution.*

## 18 Megabytes and 6 expansion slots for the PC, XT, or AT™. \$1995.

For demanding PC owners who need more versatility and memory, Sysgen introduces a powerful, reliable, and unique solution: The DISK I/O™.

It includes 6 new expansion slots for your choice of plug-in



boards, plus, an 18 MByte hard disk—all for slightly more than a hard disk alone.

Sysgen offers the full range of expansion, storage, and tape back-up solutions with the best performance ratings for the IBM® PC, XT, AT and compatibles.

For more information on the Sysgen family of expansion products contact your local dealer.

**SYSGEN** 47853 Warm Springs Blvd.,  
Fremont, CA. 94539  
INCORPORATED (415) 490-6770 Telex 4990843

Trademarks: Sysgen, DISK I/O—Sysgen, Inc.; AT—International Business Machines Corporation. Registered trademarks: IBM—International Business Machines Corporation.



nice project, and I plan to construct one.

Two questions: You mentioned that the telephone company occasionally puts a 200-V test signal on the line. Doesn't this have an adverse effect on modems and electronic equipment such as Demon Dialers?

Also, as a practical matter, what are the risks from lightning to equipment connected to the telephone system? Again, I'm concerned about modems and electronic dialers. I have seen protection devices marketed for telephone equipment, but I don't know if they're really needed and if they really work.

Thanks for the information. I always look forward to your articles as the highlight of BYTE!

CHARLES J. OKSTEIN  
Willimantic, CT

*Commercial telephone equipment is designed to survive all normally occurring voltages on the telephone line. In the case of the Whimsi-Bell, the TCM1520A has the protection built into it, and none of the other components are connected*

*to the line. In some cases, a DAA (data-access arrangement) is required to provide protection for both the equipment and the telephone lines.*

*The telephone company incorporates lightning protection into the telephone-line system to protect its own equipment, so customer equipment that meets the telephone company's specifications is pretty safe. Lightning arrestors are installed where the lines enter customer buildings to protect equipment within. Of course, there is always the possibility of damage from a lightning strike on the lines in your immediate vicinity. Local protection in addition to the normal arrestors might be justified in some cases.*  
—Steve

**TRUMP CARD FOR TRS-80?**

Dear Steve,

I read with interest your pair of articles on adding the Z8000 coprocessor to the IBM PC. I do not have an IBM PC or any of the umpteen PC-compatible computers. I'm still stuck in the 8-bit world with a

TRS-80 Model I and a Big Board II. I was wondering if you would consider (if it is possible) rewriting the loader program for Z80 machines. I am sure that there would be a large market for the board and software in the 8-bit market.

If the above is not possible, would it be feasible to buy a Co-Power 88 (an 8088 coprocessor) for the Big Board II and redesign the Z8000 board a little for use in my STD bus connector? I would think that the loader program for the Z8000 would have to be modified, but not as extensively as rewriting the loader for use on a different processor.

Now, down to the business end. How much would it cost to buy the software mentioned in your article? And where can I find the following integrated circuits?

- Z8001 Processor
- Z8581 Clock Generator
- Z8030 Serial Communications Controller
- Z8036 Counter/Timer and Parallel I/O Unit

MARK HAMPTON  
Cocoa, FL  
*(continued)*

**INTEGRATE!**

What YOU Want!  
What YOU Like!  
What YOU Already Own!

If you own an IBM™PC or compatible using IBM™PC DOS or MS-DOS™, **«MEMORY/SHIFT»** can give you the capability of making **your own** integrated package of compatible software... plus...

- two monitor capability
- up to 9 program partitions
- ability to transfer data quickly
- rapid switching between programs

**It costs only \$99 to be SELECTIVE at leading computer stores.**

Designed for most versions of IBM™PC DOS and MS-DOS™ by  
**North American Business Systems, Inc.**  
 642 Office Parkway St. Louis, Missouri (314) 432-6106  
 IBM is a registered trademark of International Business Machines Corporation  
 MS-DOS is a registered trademark of Microsoft Corporation

# BYTE

The Small Systems Journal  
A McGraw-Hill Publication  
70 Main Street  
Peterborough, New Hampshire 03458



# INTRODUCING TIPS . . .

# BYTE

The Small Systems Journal

70 Main Street  
Peterborough, New Hampshire 03458  
Telephone 603/924-9281

Dear Subscribers & Advertisers,

April 1985

Byte has upgraded the Reader Service benefit by offering **TIPS**, Telephone Inquiry Processing System, to better service both our subscribers and our advertisers. **TIPS** is a subdivision of **AIMS**, Automated Inquiry Management System.

**TIPS** expedites the Reader Service process by enabling our subscribers to directly input their Reader Service request into our Reader Service computer. Subscribers use **TIPS** as an alternative to the Reader Service postcard. **TIPS** eliminates the mailing and handling delays of the Reader Service postcard inquiry, and any additional delays at the fulfillment house. Overall **TIPS** cuts Reader Service response time by ten business days, so that subscribers get their requests to the advertisers faster.

Using **TIPS** is fast, efficient and easy. Subscribers with touch tone phones access our Reader Service computer using their personal subscriber I.D. number. They then key in their requests for additional information pertaining to advertised products. Every issue of Byte provides subscribers with **TIPS** instructions below our Reader Service index.

Advertisers benefit too. The direct inquiry requests through **TIPS** enable advertisers to receive requests from consumers more quickly. Subscribers responding via **TIPS** are active, interested prospects. They want your product information fast. They pay for the phone call in order to obtain the information they need as soon as possible. Advertisers can easily identify the **TIPS** requests because all **TIPS** leads are marked.

We at Byte believe access to **TIPS** is an excellent benefit. We are pleased to be able to offer such a state-of-the-art system to our subscribers and to our advertisers. The implementation of **TIPS** and the use of the standard Reader Service postcard will continue to develop and maintain solid communications between our readers and our advertisers. We feel that this is very important as we remain the leader of consumer computer magazines.

Sincerely,

Cynthia D. Sands

Cynthia D. Sands

Reader Service Coordinator

P.S. Look for further information on **TIPS**.

A McGraw-Hill Publication





Since the Trump Card articles appeared, I have had many requests to modify the Trump Card hardware and software to operate on different machines. Unfortunately, each system would require a slightly modified hardware and software interface. The hardware and software design time to do this would severely cut into my other Circuit Cellar projects, so I am making no plans to con-

vert the Trump Card project to any other system.

The Trump Card has been tested on several PC-compatible systems using MS-DOS and has worked fine. Since the Co-Power 88 operates under MS-DOS, it is possible that the Trump Card software will work with the system. However, since I have never tried this configuration, I cannot guarantee that it will work.

Under my "Reward for Diligence" program discussed in the first part of the Trump Card article, I will send you the Trump Card software and the Trump Card manual for the cost of duplicating and mailing (\$30), if you send me a picture of your Trump Card project.

The Zilog chips can be obtained from any of the Zilog distributors near you. In Florida, the Zilog sales offices are Dyne-A-Mark Corp. in Clearwater and Palm Bay and Technical Center-Zilog Corp. in Clearwater.—Steve

# You're in Good Company When You Program in BetterBASIC



All of these companies rely on BetterBASIC to write their software programs. They have found that BetterBASIC combines the features they need from BASIC, Pascal, C and Fort in one familiar environment. Some of these features include the following.

**640K** Now you can use the full memory of your PC to develop large programs.

**STRUCTURED** Create well organized programs using procedures and functions that are easily identified and understood and completely reusable in future programs.

**MODULAR** Use procedures and functions grouped together to form "library modules."

**INTERACTIVE** BetterBASIC acts like an interpreter, responding to the users' commands in an immediate mode. However, each statement is actually compiled as it is entered.

**EXTENSIBLE** Create your own BetterBASIC modules which contain BetterBASIC extensions (ideal for OEMs).

**COMPILED** Each line of the program is compiled as it is entered

into the computer's memory rather than interpreted at runtime. The optional Runtime System generates EXE files.

**BetterBASIC** Runs on IBM PC, IBM PC/XT and compatibles.

**CALL 1-800-225-5800** Order Better BASIC now, or write Summit Software Technology, Inc.™, P.O. Box 99, Babson Park, Wellesley, MA 02157. Prices are listed below.

BetterBASIC: \$199 Runtime System: \$250  
8087 Math Module: \$99

Still not convinced? Order the BetterBASIC sample disk which includes a demo, a tutorial, compatibility issues, 50 lines of BetterBASIC and more. Only \$10.

MasterCard, VISA, P.O. Checks, Money Order, C.O.D. accepted.

BetterBASIC is a registered trademark of Summit Software Technology, Inc.

IBM PC and IBM PC/XT are registered trademarks of International Business Machines Corp. Tandy is a registered trademark of Tandy Corp. Illustrated above are registered trademarks of the following companies: Mobil Oil Corp.; A T & T; General Electric Co.; Westinghouse Electric Corp.; TRW, Inc.

## Better BASIC™

ALSO AVAILABLE FOR THE TANDY 2000, 1200 AND 1000

## EMI

Dear Steve,

Because I live in a metropolitan area, EMI is a problem. Within a few blocks of my apartment are a 10-kW (100-kW ERP) FM transmitter, about six microwave relays, and possibly other transmitters. I want to retrofit an old TRS-80 Model I, printer, video display, and other peripherals. What regions of a computer are most susceptible to EMI? Would replacing LS ICs with HCT or HC ICs increase immunity to effects of EMI?

JAMES HAWKINS  
Kansas City, MO

*Electromagnetic-interference problems in microcomputer systems can come from any number of sources. Usually, electrical noise from an outside source is induced into cables that lead into (and out of) the computer. Sensitive circuits in the computer can also be affected if they are not properly shielded.*

*Since the subject of electromagnetic-interference elimination is too long to be properly discussed in a letter, I will refer you to an article I wrote that covers the subject in depth. The article, appropriately called "Electromagnetic Interference," can be found in the January 1981 BYTE.*

—Steve ■

Over the years I have presented many different projects in BYTE. I know many of you have built them and are making use of them in many ways.

I am interested in hearing from any of you telling me what you've done with these projects or how you may have been influenced by the basic ideas. Write me at Circuit Cellar Feedback, POB 582, Glastonbury, CT 06033 and fill me in on your applications. All letters and photographs become the property of Steve Ciarcia and cannot be returned.

# Cure development headaches with our \$105\* Controller



\*BCC11 100 quantity or  
qualified buyers' price.

At \$105, Micromint's System Controller is a dirt cheap development tool without equal.

It'll turn your IBM PC into a design laboratory that saves your company thousands of dollars and months of evaluation. You'll save headaches, too. When you tell your boss the first phase of your pet project is only going to cost \$105, watch the relief begin.

Micromint's Z8 System Controller, the tiny computer on a board, is the cornerstone of an entire family of integrated, intelligent products from AC/IO to smart terminals. Able to speak three languages (BASIC, FORTH and Assembly), this tiny 4" x 4 1/2" computer supports 6K bytes of EPROM or 4K bytes of RAM, two parallel ports and an RS-232 serial port.

If learning a new language isn't in your future, no problem. **WRITE YOUR PROGRAMS IN BASIC AND TRANSLATE THEM INTO FORTH WITH A SINGLE KEY STROKE.** Our specially masked chip will let you know in an instant whether your program is operational. You'll be building before the competition is de-bugging.

For OEM Orders and Customer Assistance Call Our Toll Free Line

## 1-800-521-0044



Call or write for a complete product line brochure. Or order our complete set of 12 fully detailed owners' and technical reference manuals for only \$29.95. This set includes all of the following manuals:

- Z8 FORTH System Controller
- Z8 BASIC System Controller
- BASIC/Debug Software Reference
- Z8 Microcomputer Assembly Language/Hardware Technical Reference
- Memory and I/O Expansion
- EPROM Programmer
- Analog to Digital Converter
- 16K Memory Expansion
- Serial I/O Expansion
- RS-232/20mA Converter
- Smart Video Terminal
- AC/DC Power I/O

ORDER PRODUCT CODE BCC99.

## Micromint, Inc.

Dept. 14, 25 Terrace Drive, Vernon, CT 06066

APRIL 1985 • BYTE 413



# B.O.O.K.S R.E.C.E.I.V.E.D

ALGORITHM DESIGN FOR COMPUTER SYSTEM DESIGN, G. Ausiello, M. Lucertini, and P. Serafini, eds. New York: Springer-Verlag, 1984; 248 pages, 17 by 24 cm, softcover, ISBN 0-387-81816-2, \$18.30.

APPLE HOME COMPANION, George Beekman and Dennis Corliss. Chatsworth, CA: Datamost, 1984; 360 pages, 13.3 by 20.8 cm, softcover, ISBN 0-88190-318-3, \$19.95.

APPLE LISA: A USER-FRIENDLY HANDBOOK, Joseph Coleman. Blue Ridge Summit, PA: Tab Books, 1984; 320 pages, 18.8 by 23.5 cm, softcover, ISBN 0-8306-1691-8, \$16.95.

APPLE MACINTOSH USERS HANDBOOK, staff of Weber Systems. New York: Ballantine Books, 1984; 328 pages, 14 by 21.5 cm, softcover, ISBN 0-345-31840-4, \$9.95.

APPLE THESAURUS, Aaron Filler. Chatsworth, CA: Datamost, 1984, 896 pages, 21 by 27.5 cm, softcover, ISBN 0-88190-346-9, \$29.95.

APPLE IIE PROGRAMMING, BOOK ONE, Phil Robinson. Englewood Cliffs, NJ: Prentice-Hall, 1984; 64 pages, 21.5 by 28 cm, softcover, ISBN 0-13-038456-9, \$10.95.

ASSEMBLY LANGUAGE PROGRAMMING FOR THE TRS-80 MODEL 16, Dan Keen and Dave Dischert. Blue Ridge Summit, PA: Tab Books, 1984; 196 pages, 13 by 21 cm, softcover, ISBN 0-8306-1649-7, \$10.25.

THE BASIC EXPLORER FOR THE COMMODORE 64, Lee Berman and Ken Leonard. Berkeley, CA: Osborne/McGraw-Hill, 1985; 288 pages, 18.5 by 23.5 cm, softcover, ISBN 0-88134-139-8, \$11.95.

BASIC FUNDAMENTALS AND STYLE, James S. Quasney and John Maniotes. Boston, MA: Boyd & Fraser Publishing Co.,

1984; 480 pages, 21 by 27.5 cm, softcover, ISBN 0-87835-138-8, \$25. Includes template.

BEGINNER'S GUIDE TO MICROPROCESSORS, 2nd ed., Charles M. Gilmore. Blue Ridge Summit, PA: Tab Books, 1984; 224 pages, 12.8 by 21 cm, softcover, ISBN 0-8306-1695-0, \$9.95.

BUSINESS COMPUTING: A STRUCTURED APPROACH TO BASIC ON THE PDP-11 & VAX-11, James F. Peters III and Hamed M. Sallam. Reston, VA: Reston Publishing, 1985; 704 pages, 21.3 by 27.5 cm, softcover, ISBN 0-8359-0549-7, \$21.95.

THE BUSINESS GUIDE TO THE XENIX SYSTEM, Jean L. Yates, Sandra L. Emerson, and Candice Basham. Reading, MA: Addison-Wesley, 1984; 496 pages, 18.5 by 23.5 cm, softcover, ISBN 0-201-08847-9, \$19.95.

BUSINESS POWER FOR YOUR APPLE, Gregory R. Glau. New York: Van Nostrand Reinhold, 1984; 304 pages, 15.5 by 23.5 cm, hardcover, ISBN 0-442-22779-5, \$32.95.

THE C-64 PROGRAM FACTORY, George Stewart. Berkeley, CA: Osborne/McGraw-Hill, 1985; 336 pages, 16 by 23.5 cm, softcover, ISBN 0-88134-150-9, \$12.95.

THE COMAL HANDBOOK, 2nd ed., Len Lindsay. Reston, VA: Reston Publishing, 1984; 480 pages, 17.5 by 23.5 cm, softcover, ISBN 0-8359-0784-8, \$18.95.

CATALOGUE OF ARTIFICIAL INTELLIGENCE TOOLS, Alan Bundy, ed. New York: Springer-Verlag, 1984; 180 pages, 16.5 by 24 cm, softcover, ISBN 0-387-13938-9, \$17

COMMODORE 64 FUN AND GAMES, VOLUME 2, Ron Jeffries and Glen Fisher. New York: Warner Books, 1984; 188 pages, 21.3 by 27.5 cm, softcover, ISBN 0-446-38183-7, \$12.95.

THE COMPLETE BOOK OF LISA, Kurt J. Schmucker. New York: Harper & Row, 1984; 352 pages, 15.5 by 23.5 cm, softcover, ISBN 0-06-669008-0, \$17.95.

COMPUTER-BASED INSTRUCTION: METHODS AND DEVELOPMENT, Stephen M. Alessi and Stanley R. Trollip. Englewood Cliffs, NJ: Prentice-Hall, 1985; 432 pages, 17.5 by 23.3 cm, softcover, ISBN 0-13-164161-1-01, \$21.95.

THE COMPUTER BUYER'S SURVIVAL MANUAL, C. Amos Johnson. Blue Ridge Summit, PA: Tab Books, 1984; 224 pages, 12.8 by 20.8 cm, softcover, ISBN 0-8306-1767-1, \$9.95.

COMPUTER CARE, Herb Friedman. Englewood Cliffs, NJ: Prentice-Hall, 1984; 182 pages, 15 by 23 cm, softcover, ISBN 0-13-163833-5, \$14.95.

THE COMPUTER ENTREPRENEURS, Robert Levering, Michael Katz, and Milton Moskowitz. New York: New American Library, 1984; 496 pages, 16 by 23.5 cm, hardcover, ISBN 0-453-00477-6, \$19.95.

COMPUTER GRAPHICS AND APPLICATIONS, D. Harris. New York: Chapman and Hall, 1984; 184 pages, 15.5 by 23.3 cm, softcover, ISBN 0-412-25090-X, \$19.95.

COMPUTER LITERACY, Warren Jones, Bobbie Jones, Kevin Bowyer, and Mel Ray. Reston, VA: Reston Publishing, 1983; 304 pages, 17.5 by 23.5 cm, softcover, ISBN 0-8359-0860-7, \$16.95.

COMPUTERS AND INFORMATION PROCESSING WORLD INDEX, Suzan Deighton, John Gurnsey, and Janet Tomlinson, eds. Phoenix, AZ: The Oryz Press, 1984; 640 pages, 22 by 30 cm, hardcover, ISBN 0-89774-116-1, \$74.50.

COMPUTING FOR EXECUTIVES, J. W. Chadwick. Blue Ridge Summit, PA: Tab Books, 1984; 280 pages, 13 by 21 cm, softcover, ISBN 0-8306-1796-5, \$12.95.

CONQUERING THE COMMODORE 64 KINGDOM, Bill L. Behrendt. Englewood Cliffs, NJ: Prentice-Hall, 1984; 192 pages, 17.5 by 23.5, softcover, ISBN 0-13-167917-1, \$14.95.

COOKBOOK OF CREATIVE PROGRAMS FOR THE COMMODORE 64, Robert Rinder. New York: New American Library, 1984; 222 pages, 18 by 25.5 cm, softcover, ISBN 0-452-25571-6, \$12.95.

CREATING THE PERFECT DATABASE USING DB MASTER, Trish McClelland. Glenview, IL: Scott, Foresman and Co., 1985; 256 pages, 19.3 by 23.5 cm, softcover, ISBN 0-673-18039-5, \$17.95.

DATAPRO/MCGRAW-HILL GUIDE TO APPLE SOFTWARE, 2nd ed., Datapro Research Corporation. New York: McGraw-Hill, 1985; 362 pages, 21.5 by 28 cm, softcover, ISBN 0-07-015406-6, \$22.95.

DATAPRO/MCGRAW-HILL GUIDE TO CP/M SOFTWARE, 2nd ed., Datapro Research Corporation. New York: McGraw-Hill, 1985; 400 pages, 21.5 by 28 cm, softcover, ISBN 0-07-015408-2, \$22.95.

DATAPRO/MCGRAW-HILL GUIDE TO IBM PC SOFTWARE, 2nd ed., Datapro Research Corporation. New York: McGraw-Hill, 1985; 404 pages, 21.5 by 28 cm, softcover, ISBN 0-07-015407-4, \$22.95.

.....  
THIS IS A LIST of books received at BYTE Publications. It is not meant to be exhaustive; its purpose is to acquaint BYTE readers with recently published titles in computer science and related fields. We regret that we cannot review all the books we receive; instead, this list is meant to be a monthly acknowledgment of these books and the publishers who sent them.

(continued)

# UP TO DATA

There's only one segment of business which has the expertise to decipher reams of information on micro technology. They are the only individuals qualified to advise their companies on micro purchases. They are the elite who buy and influence billions of dollars in business micro purchases.

They are The BYTE Group. Even as you read this ad, thousands of them are quietly making recommendations in companies all

around the world. You should keep them up to date on what you have to offer.

Call us. We'll lend you their ear. Because BYTE is business. And the business is micros. If you want to reach the business professional who is at the leading edge of micro technology, advertise in BYTE. For more information, call (603) 924-9281.

## BYTE MEANS BUSINESS

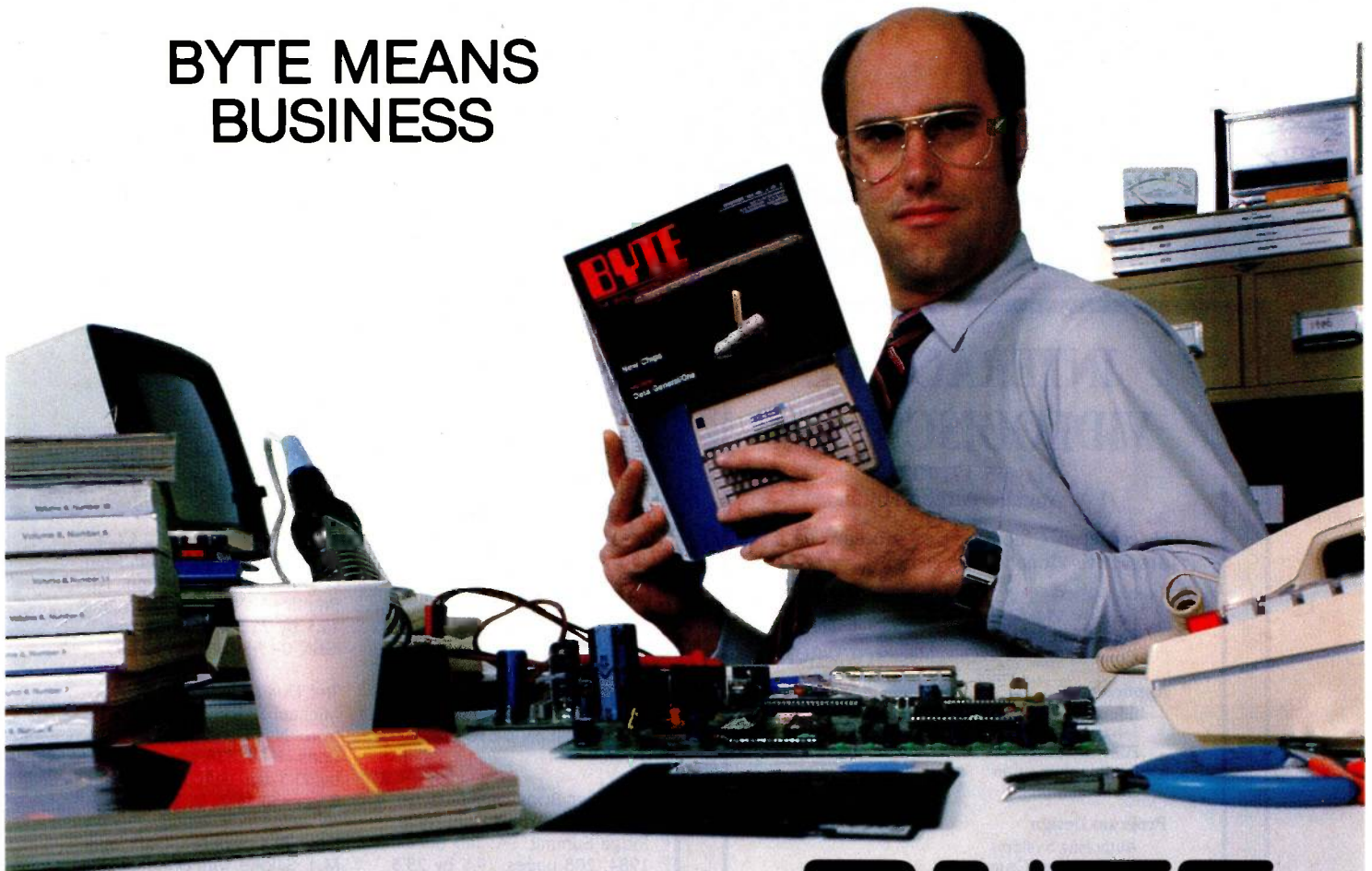

For subscription information, call 1-800-258-5485.

# BYTE

THE SMALL SYSTEMS JOURNAL  
70 Main Street, Peterborough, NH 03458







# LIONHEART

## BUSINESS & STATISTICAL SOFTWARE

Explanatory books with professional compiled software; the new standard for statistical use. The influential Seybold Report on Professional Computing has this to say about Lionheart "...our sentimental favorite because of its pragmatic approach to the basic statistical concepts... The thinking is that the computer merely facilitates the calculations; the important thing is to be able to formulate a problem correctly and to determine what type of analysis will be most valuable."

- **BUSINESS STATISTICS** ..... \$135
- **EXPERIMENTAL STATISTICS** ..... 115
- **EXPLORATORY DATA ANALYSIS** ..... 75
- **FORECASTING AND TIME-SERIES** ..... 115
- **BUSINESS AND ECONOMIC FORECASTING** ..... 135
- **DECISION ANALYSIS TECHNIQUES** ..... 85
- **LINEAR & NON-LINEAR PROGRAMMING** . 75
- **PERT & CRITICAL PATH TECHNIQUES** ... 75
- **MONTE CARLO SIMULATION** ..... 125
- **OPTIMIZATION** ..... 80

PC/MS-DOS, CP/M (Apple and Macintosh formats slightly more expensive) Add \$2 per book for shipping and handling.

VISA, MasterCard, AMEX, Check  
**P.O. Box 379, ALBURG, VT 05440**  
**(514) 933-4918**

## Announcing **INTERACTIVE VIDEODISC WEST**

May 15-17, 1985  
 Los Angeles Airport Hilton

**This conference includes presentations on Interactive Videodisc covering:**

**Technologies**

- Level IV Videodisc
- Sound over Still Frame
- Compact Disc/Read Only Memory (CD-ROM)

**Applications**

- Education and Industrial Training
- Job Performance Assistance
- Point of Sale
- Public Information
- Archival Storage

**Program Design**

- Authoring Systems
- Effectiveness Criteria
- Courseware Transportability

**Pre-conference tutorials** are scheduled for May 14.

**Exhibits** by Pioneer, Sony, JVC, 3M, EECO, DEC, and other leading suppliers of hardware, software, and interface systems will be available to conference registrants in an adjacent exhibit area.

For further information contact:

**Society for Applied Learning Technology**  
 50 Culpeper St., Dept. B  
 Warrenton, VA 22186 (703) 347-0055

## BOOKS RECEIVED

**THE DESIGNER'S GUIDE TO DISK DRIVES**, Edward R. Teja. Reston, VA: Reston Publishing, 1985; 142 pages, 18 by 24 cm, hardcover, ISBN 0-8359-1268-X, \$29.95.

**DESIGNING APPLE GAMES WITH PIZAZZ!** Greg Minter and John Ruffner. Chatsworth, CA: Datamost, 1984; 328 pages, 17.8 by 25.3 cm, softcover, ISBN 0-88190-387-6, \$14.95.

**DICTIONARY OF COMPUTING AND NEW INFORMATION TECHNOLOGY**, A. J. Meadows, M. Gordon, and A. Singleton. New York: Nichols Publishing, 1984; 232 pages, 13.3 by 20.5 cm, hardcover, ISBN 0-89397-197-9, \$24.50.

**DIGITAL SYSTEMS, PRINCIPLES AND APPLICATIONS**, 3rd ed., R. J. Tocci. Englewood Cliffs, NJ: Prentice-Hall, 1985; 608 pages, 18.3 by 24.3 cm, hardcover, ISBN 0-13-212374-6, \$29.95.

**DISCOVERING SCIENCE ON YOUR ADAM WITH 25 PROGRAMS**, John Pellino, Mary Ellen Adamo, Sandra Dobrowsky, and Donald P. LaSalle. Blue Ridge Summit, PA: Tab Books, 1984; 192 pages, 19 by 23.5 cm, softcover, ISBN 0-8306-1780-9, \$9.95.

**ESSENTIAL APPLICATIONS FOR THE IBM PC AND XT**, Patrick Plemmons and the editors of *PC World*. New York: Simon & Schuster, 1984; 256 pages, 19 by 23.5 cm, softcover, ISBN 0-671-49279-9, \$16.95.

**FINANCIAL DECISION MAKING WITH YOUR TRS-80 MODEL 100**, Leslie Sparks. Blue Ridge Summit, PA: Tab Books, 1984; 142 pages, 18.5 by 23.5 cm, softcover, ISBN 0-8306-1799-X, \$9.95.

**THE FIRST BOOK OF ADAM THE COMPUTER**, Arthur Dent. Blue Ridge Summit, PA: Tab Books, 1984; 208 pages, 19.5 by 23.5 cm, softcover, ISBN 0-8306-1720-5, \$9.25.

**FUN, GAMES & GRAPHICS FOR THE APPLE II, IIe & IIc**, Paul Garrison. Blue Ridge Summit, PA: Tab Books, 1984; 316 pages, 18.5 by 23.3 cm, softcover, ISBN 0-8306-1752-3, \$13.95.

**THE FUTURE OF SEMICONDUCTORS, COMPUTERS, ROBOTICS,**

**AND TELECOMMUNICATIONS**, editorial staff of Petrocelli Books. Princeton, NJ: Petrocelli Books, 1984; 264 pages, 16 by 24 cm, hardcover, ISBN 0-89433-259-7, \$49.95.

**GAMES & UTILITIES FOR THE TRS-80 MODEL 100**, Ron Karr, Steven Olsen, and Robert Lafore. New York: New American Library, 1984; 204 pages, 18.5 by 23.5 cm, softcover, ISBN 0-452-25577-5, \$16.95.

**GETTING THE MOST FROM YOUR POCKET COMPUTER**, Stephen F. Nowak. Blue Ridge Summit, PA: Tab Books, 1984; 236 pages, 13 by 21 cm, softcover, ISBN 0-8306-1723-X, \$9.95.

**GETTING STARTED IN PASCAL PROGRAMMING**, J. Camara and F. Puccetti. Blue Ridge Summit, PA: Tab Books, 1984; 206 pages, 18.5 by 23.5 cm, softcover, ISBN 0-8306-0588-6, \$12.95.

**HANDBOOK OF BAR CODING SYSTEMS**, H. E. Burke. New York: Van Nostrand Reinhold, 1984; 240 pages, 16 by 23 cm, hardcover, ISBN 0-442-21430-8, \$42.50.

**HIDDEN POWERS OF THE TRS-80 MODEL 100**, Christopher L. Morgan. New York: New American Library, 1984; 254 pages, 18.5 by 23 cm, softcover, ISBN 0-452-25578-3, \$19.95.

**A HOBBYIST'S GUIDE TO COMPUTER EXPERIMENTATION**, John D. Lenk. Englewood Cliffs, NJ: Prentice-Hall, 1985; 300 pages, 15.5 by 23.5 cm, hardcover, ISBN 0-13-392473-4, \$23.95.

**THE HOME COMPUTER WARS**, Michael S. Tomczyk. Greensboro, NC: Compute! Publications, 1984; 318 pages, 14 by 21.5 cm, softcover, ISBN 0-942386-75-2, \$9.95.

**HOW TO COPYRIGHT SOFTWARE**, M. J. Salone with Stephen Elias, legal ed. Berkeley, CA: Nolo Press, 1984; 256 pages, 21 by 27.5 cm, softcover, ISBN 0-917316-79-7, \$21.95.

**HOW TO PROGRAM YOUR IBM PC COLOR & GRAPHICS**, Carl Shipman. Tucson, AZ: HPBooks, 1984; 320 pages, 21.5 by 27.5 cm, softcover, ISBN 0-89586-265-4, \$21.95.

(continued)

Train for the Fastest Growing Job Skill in America

# Only NRI teaches you to service and repair all computers as you build your own 16-bit IBM-compatible micro

As computers move into offices and homes by the millions, the demand for trained computer service technicians surges forward. The Department of Labor estimates that computer service jobs will actually *double* in the next ten years—a faster growth than any other occupation.

## Total System Training

As an NRI student, you'll get total hands-on training as you actually build your own Sanyo MBC-550-2 computer from the keyboard up. Only a person who knows *all* the underlying fundamentals can cope with *all* the significant brands of computers. And as an NRI graduate, you'll possess the up-to-the-minute combination of theory and practical experience that will lead you to success on the job.

You learn at your own convenience, in your own home, at your own comfortable pace. Without classroom pressures, without rigid night-school schedules, without wasted time. Your own personal NRI instructor and NRI's complete technical staff will answer your questions, give you guidance and special help whenever you may need it.

## The Exciting Sanyo MBC-550-2—Yours To Keep

Critics hail the new Sanyo as the "most intriguing" of all the IBM-PC compatible computers. It uses the same 8088 microprocessor as the IBM-PC and the MS/DOS operating system. So, you'll be able to choose thousands of off-the-shelf software programs to run on your completed Sanyo.

As you build the Sanyo from the keyboard up, you'll perform demonstrations and experiments that will give you a total mastery of computer operations and servicing techniques. You'll do programming in BASIC language. You'll prepare interfaces for peripherals such as printers and joysticks. Using utility programs, you'll check out 8088 functioning. NRI's easy step-by-step directions will guide you all the way right into one of today's fastest growing fields as a computer service technician. And the entire



NRI is the only home study school that trains you as you assemble a top-brand micro-computer. After building your own logic probe, you'll assemble the "intelligent" keyboard...

Your NRI Course Includes a Sanyo MBC-550-2 Computer with 128K RAM, Monitor, Disk Drive, and "Intelligent" Keyboard; The NRI Discovery Lab®, Teaching Circuit Design and Operations; a Digital Multimeter; Bundled Spread Sheet and Word Processing Software Worth \$1500 at Retail—and More.

system, including all the bundled software and extensive data manuals, is yours to keep as part of your training.

## 100-Page Free Catalog Tells More

Send the postage-paid reply card today for NRI's big 100-page color catalog, which gives you all the facts about NRI training in Microcomputers, Robotics, Data Communications, TV/Video/Audio Servicing, and other growing high-tech career fields. If the card is missing write to NRI at the address below.

... then install the computer power supply, checking all the circuits and connections with NRI's Digital Multimeter. From there you'll move on to install the disk drive and monitor.

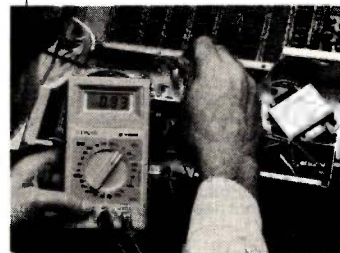

**NRI** SCHOOLS

McGraw-Hill Continuing Education Center

3939 Wisconsin Avenue, NW  
Washington, DC 20016

We'll Give You Tomorrow.

IBM is a Registered Trademark of International Business Machine Corporation.

Return Coupon to: Lifeboat™ Associates  
1651 Third Avenue, New York, NY 10128

© 1985 Lifeboat Associates

BY-4



# Sailing on the changing tides of business, there is no room for uninformed decisions.

You don't go sailing without the right navigational instruments.

And you don't make business decisions without the right information.

With Dow Jones Straight Talk™ and your Macintosh™ personal computer, you have the right information to make seaworthy business decisions.

## **Widgets, Inc.: To Acquire or Not?**

Let's say you need to know everything you can about Widgets, Inc. and the entire miniwidgets industry. You're thinking about an acquisition. You need solid research.

And you need it for the important meeting at 4 p.m.

## **Dow Jones Straight Talk: Helping You Make Informed Decisions**

Straight Talk can help. Straight Talk could even make you a hero. Here's how: Two clicks of the mouse and you're logged on to the information you need with Dow Jones News/Retrieval, the foremost electronic resource for business and financial information, and other communications services.

With pull-down menus, you can move easily between databases, checking current news and stock quotes, reviewing exclusive stories from the up-to-date file of **The Wall Street Journal**, searching out financial information on a specific corporation or industry.

Now use your Clipboard, Note Pad and Scrapbook to save it.

Since Straight Talk supports MacWrite,™ you can thread all this data together with your own informed comments.

Now the final report: Use the different type sizes and styles to highlight special sections for your boss. Your conclusion: Don't acquire the company. It's on thin ice.

With Straight Talk, hours worth of research can be condensed into just minutes.

And, as the meeting ends, you can barely hold back that big grin.

From now on your career should be smooth sailing.

## **A World of Information on Your Desk**

At \$79, Dow Jones Straight Talk is the least expensive, most diligent researcher and electronic know-it-all you'll ever come across.

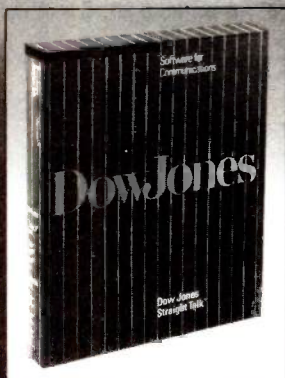

**Dow Jones Software. For informed decisions.**

Dow Jones News/Retrieval is a registered trademark of Dow Jones & Company, Inc. Dow Jones Software and Dow Jones Straight Talk are trademarks of Dow Jones & Company, Inc. Macintosh is a trademark licensed to Apple Computer, Inc. MacWrite is a trademark of Apple Computer, Inc.

Copyright © 1985 Dow Jones & Company, Inc. All Rights Reserved.

In addition to business and financial information, you can click into world and national news, sports, weather, an encyclopedia, airline schedules and fares, movie reviews and MCI mail.

And Straight Talk is from Dow Jones, publisher of **Barron's** and **The Wall Street Journal**, and for over 100 years a standard in timely, reliable information.

Dow Jones Straight Talk for the Macintosh. A precision instrument designed to make sure your ship comes in.

To obtain a free brochure and information on where you can conveniently purchase Dow Jones Straight Talk, fill out the coupon or call:

**1-800-345-8500 ext. 272**

(Alaska, Hawaii and foreign call 1-215-789-7008 ext. 272)

Inquiry 127

Fill out this coupon and mail to:  
A. Callahan, Dow Jones & Company,  
P.O. Box 300, Princeton, N.J. 08540.

Yes, please send me a free brochure on  
Dow Jones Straight Talk™ and  
Dow Jones News/Retrieval®.

Name \_\_\_\_\_

Company \_\_\_\_\_

Address \_\_\_\_\_

City \_\_\_\_\_ State \_\_\_\_\_

Zip \_\_\_\_\_ Phone \_\_\_\_\_

**Dow Jones**  
Software™

CBD



*"I think we turn left here."*



**COMPUPRO USERS**

**Accelerate Your Compupro**  
with a free

**CPU UPGRADE BOARD**  
call for details

provided with a **DATABANK SMD subsystem**  
**DATABANK SMD DISK STORAGE SUBSYSTEMS**  
Turnkey Systems —Desktop Enclosure  
Controller, Drive, MP/M 816 Concurrent DOS.  
**84 MBYTE    168 MBYTE    300 MBYTE**  
**FUJITSU      FUJITSU      PERTEC**  
**\$8,990.00    \$10,990.00    \$12,990.00**

Databank is your single source supplier for S-100 systems, subsystems and board level products from leading hardware manufacturers as well as our own DATABANK SMD storage subsystems. Periphery by FUJITSU, PERTEC, ALLOY and CONTROL DATA.

Databank SMD Disk Subsystems are also available for PC buss network applications. **DEALER INQUIRY INVITED**

For further information call or write:

**DATABANK** 228A West Carrillo  
Santa Barbara, CA  
**805 965-3404**

**NOVA** PC/XT THE TOP OF THE LINE IBM COMPATIBLE COMPUTER

**NOVA PC SYSTEM                    \$1595.00**

1 Hitec Keyboard, 1 130W Power Supply, \*\*\*1 AST 6 Pack Compatible Multifunction Board, 1 Monitor, 4 Drive Controller.

**NOVA XT SYSTEM                    \$2345.00**

1 130W Power Supply, 1 Hitec Keyboard, 1 Monitor, \*\*\*1 AST 6 Pack Compatible Multifunction Board, 1 360K Floppy Disk Drive, 4 Drive Controller, 1 10MB Hard Disk, DTC Hard Disk Controller Card, 1 Color Graphic Board.

**NOVA 64K BASIC SYSTEM            \$750.00**

1 64K Nova Mother Board, Dr. Controller, 1 Hitec Keyboard, 1 130W Power Supply (110/220V), 1 Case.

**REMARK:**

\*\*\*1 Serial Port, 1 Parallel Port, 1 Game Port, Clock, Memory can be expansion up to 348K, Spool, RAMDISK.

**NOVA PC/XT BARE BOARD w/MANUAL    \$79.00**

**DISK DRIVE**

Shugart SA455 1/4 Drive ..... \$110.00  
Shugart SA712 10 MB

Hard Disk Drive ..... \$475.00  
TEAC 55B 1/2 Floppy Drive ..... \$115.00

Miniscribe 10MB H.D. w/Controller & Cable ..... \$650.00  
Miniscribe 20MB Hard Disk Drive ... \$695.00

**UPGRADE KITS FOR AT**  
412 8K RAM ..... \$20.00  
80287 Co-Processor ..... \$145.00

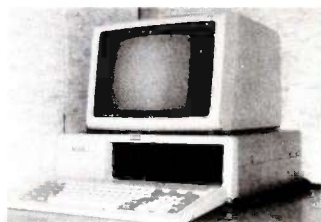

**HARDWARE**

The Best Quality 130W Power Supply ..... \$150.00  
(110/220V) Same Dimension as IBM Power Multifunction Card ..... \$195.00  
Case ..... \$90.00  
Hitec Keyboard ..... \$130.00  
Color Graphic Card ..... \$170.00  
Hercules Compatible Mono Chrome Card ..... \$195.00  
Floppy Disk Controller Card w/Cable ..... \$120.00

**STREAM TAPE**

10/20 MB Stream Tape for Backup .... CALL

**MONITOR**

Amdek 300 Color Monitor ..... \$245.00  
Amdek 310 ..... \$143.00  
Amdek 310A ..... \$147.00  
Amdek RGB 600 Color Monitor ..... \$445.00  
Amdek RGB 700 Color Monitor ..... CALL

DEALER INQUIRIES WELCOME. — NOVA PC/XT KITS AVAILABLE

**COMPUTRADE COMPANY** (in Koll Commercial Center)

780 Trimble Road, Suite 605, San Jose, CA 95131

Tel. (408) 946-2442, Telex: 171605

Hours: Mon-Fri 9:00 a.m.-6:00 p.m.

**BOOKS RECEIVED**

LEARNING COMMODORE 64 LOGO TOGETHER. Kenneth P. Goldberg. Bellevue, WA: Microsoft Press. 1984; 446 pages. 18.5 by 23.5 cm. softcover. ISBN 0-914845-24-1. \$14.95.

LOGO FOR APPLE COMPUTERS: A SELF-TEACHING GUIDE. R. W. Haigh and L. E. Radford. New York: John Wiley & Sons, 1984; 320 pages. 17 by 25 cm. softcover. ISBN 0-471-88023-X. \$14.95.

MACINTOSH: THE APPLIANCE OF THE FUTURE. Gerard Lewis. Wayne, PA: Banbury Books. 1984; 376 pages. 18.8 by 23.5 cm. spiral-bound. ISBN 0-88693-031-6. \$14.95.

MASTERING BASIC ON THE TRS-80 MODEL 100. Bernd Enders. New York: New American Library. 1984; 350 pages. 18.5 by 23.5 cm. softcover. ISBN 0-452-25575-9. \$19.95.

MASTERING MULTIPLAN. David Bolocan, Saechin Kim, Ray King, and Lauren Singer. Blue Ridge Summit, PA: Tab Books, 1984; 128 pages. 19.5 by 23 cm. softcover. ISBN 0-8306-1743-4. \$11.50.

MASTERING THE TANDY 2000. Dan Keen and Dave Dischert. Blue Ridge Summit, PA: Tab Books, 1984; 160 pages. 19 by 23.5 cm. softcover. ISBN 0-8306-1829-5. \$10.95.

McGRAW-HILL DICTIONARY OF ELECTRONICS AND COMPUTER TECHNOLOGY. Sybil P. Parker, ed. New York: McGraw-Hill, 1984; 592 pages. 16 by 23.5 cm. hardcover. 0-07-045416-7. \$32.50.

METHODS AND TOOLS FOR COMPILER CONSTRUCTION. B. Lorho, ed. New York: Cambridge University Press, 1984; 416 pages. 15.5 by 23.5 cm. hardcover. ISBN 0-521-26843-5. \$49.50.

MICRO ACCOUNTING. Steven E. Yoder and Sherry D. Knight. Englewood Cliffs, NJ: Prentice-Hall, 1985; 282 pages. 17.5 by 23.5 cm. softcover. ISBN 0-13-580085-4. \$15.95.

MOD4 BY JACK. Jack Klein. Durango, CO: Crest Software. 1984; 218 pages. 15 by 22.5 cm. spiral-bound. ISBN 0-930615-00-X. \$9.95.

MODULA-2 FOR PASCAL PROGRAMMERS. Richard Gleaves. New York: Springer-Verlag, 1984; 160 pages. 15.5 by 23.5 cm. softcover. ISBN 0-387-96051-1. \$16.95.

MORE BASIC: A GUIDE TO INTERMEDIATE-LEVEL COMPUTER PROGRAMMING. Shelley Lipson. New York: Holt, Rinehart and Winston, 1984; 80 pages. 14.5 by 21.5 cm. hardcover. ISBN 0-03-070722-6. \$9.95.

THE ONE MINUTE METHODOLOGY. by E. Z. Systems as told to Ken Orr. Topeka, KS: Ken Orr and Associates, 1984; 70 pages. 14.5 by 22.3 cm. hardcover. ISBN 0-9605884-3-4. \$8.95.

PAYCALC: HOW TO CREATE CUSTOMIZED PAYROLL SPREADSHEETS. Thomas E. Towle. Blue Ridge Summit, PA: Tab Books, 1984; 112 pages. 18.5 by 23.5 cm. softcover. ISBN 0-8306-1694-2. \$15.50.

PERFECT SOFTWARE 2.0 FOR YOUR IBM PC & COMPATIBLES. Howard H. Wade and Martin Lenk. Reston, VA: Reston Publishing, 1984; 222 pages. 21 by 28 cm. softcover. ISBN 0-8359-5495-1. \$21.95.

PRACTICAL FINANCE ON THE TRS-80 MODEL 100. S. Venit and Diane Burns. New York: New American Library, 1984; 174 pages. 18.5 by 23.5 cm. softcover. ISBN 0-452-25576-7. \$15.95.

PROGRAMMING LANGUAGES: FEATURING THE IBM PC AND COMPATIBLES. Marc Stiegler and Bob Hansen. New York: Baen Enterprises, 1984; 448 pages. 13.5 by 21 cm. softcover. ISBN 0-671-55929-X. \$9.95.

PROGRAMMING LANGUAGES AND THEIR DEFINITION. Lecture Notes in Computer Science #177. H. Bekič. New York: Springer-Verlag, 1984; 288 pages. 16.5 by 24.3 cm. softcover. ISBN 0-387-13378-X. \$13.

PROGRAMMING YOUR OWN ADVENTURE GAMES IN PASCAL. Richard C. Vile Jr. Blue Ridge Summit, PA: Tab Books, 1984; 318 pages. 18.5 by 23.5 cm. softcover. ISBN 0-8306-1768-X. \$13.95.

(continued)

# THE IBM AT: ENHANCE IT RIGHT, RIGHT NOW.

**With The Bernoulli Box.™ Winchester Performance And Reliability.  
Cartridge Economy And Versatility.**



*Now* is the time to harness all of the potential of the new IBM AT to the growing demands of your business.

And with The Bernoulli Box, *now* you can. This unique cartridge data management system, attached to a standard IBM AT without the hard disk, creates a powerful processing package that only mass storage capabilities can make possible. A package with all of the performance and reliability you only thought possible with a Winchester-enhanced IBM AT, but with dramatically more versatility and dramatically less cost per megabyte.

The secret is virtually indestructible, go-anywhere, 10-megabyte cartridges whose

proprietary technology has proven The Bernoulli Box the superior storage solution for a whole range of business micros from the IBM PC to the Macintosh,™ from the XT to the AT&T.

And remember this. The Bernoulli Box has been designed for all versions of the IBM AT. Which means it will give you virtually unlimited cartridge-based primary storage as well as unparalleled backup capabilities.

That's The Bernoulli Box. From IOMEGA. Call 1-800-556-1234, ext. 215 for the dealer nearest you. In California, call 1-800-441-2345, ext. 215.

**IOMEGA®**

IOMEGA Corporation  
1821 West 4000 South  
Roy, Utah 84067

# THE BERNOULLI BOX™



# FREE SHIPPING DISKETTES

West Coast "Call" Central & East "Call"  
**1(800) 621-6221 1(800) 654-4058**  
 Discounts Starting at 3 Box Quantities

<b>3M</b> • 5 1/4" s-side 17 <sup>95</sup> d-den. 23 <sup>95</sup> d-side 27 <sup>50</sup> quad 33 <sup>95</sup> • 8" s-side 21 <sup>50</sup> s-den. 26 <sup>00</sup> d-den. 31 <sup>50</sup>	<b>Dysan</b> • 5 1/4" s-side 22 <sup>95</sup> d-den. 30 <sup>50</sup> d-side 34 <sup>50</sup> quad 45 <sup>50</sup> • 8" s-side 28 <sup>50</sup> s-den. 30 <sup>95</sup> d-den. 34 <sup>95</sup>	<b>maxell</b> 3 1/2" CALL • 5 1/4" s-side 19 <sup>95</sup> d-den. 25 <sup>95</sup> d-side 28 <sup>95</sup> quad 36 <sup>95</sup> • 8" s-side 31 <sup>95</sup> d-den. 34 <sup>95</sup>	<b>Verbatim</b> • 5 1/4" Datalife s-side 18 <sup>95</sup> d-den. 24 <sup>95</sup> d-side 30 <sup>95</sup> quad 39 <sup>95</sup> • 8" Datalife s-side 24 <sup>75</sup> s-den. 26 <sup>95</sup> d-den. 31 <sup>95</sup>
<b>3M</b> DC100A...13 <sup>95</sup> DC300A...18 <sup>40</sup> DC300XL 20 <sup>25</sup> DC600A...24 <sup>45</sup>	<b>AMARAY MEDIA MATE</b> (3 1/2"...1195) (5 1/4"...1195) <b>DISK MINDERS</b> (5 1/4"...1675) (8"...2150) <b>BULK PACKED DISKS "CALL"</b>	<b>Head Cleaners</b> Kits...520 <b>Refills...955</b> <b>Analizers 2500</b>	

Diskettes 10/Box  
 the **Diskette Connection™**  
 Dealer Inquiries Welcomed  
 1(800) 654-4058  
 MasterCard OKLAHOMA & NEVADA VISA  
 \*UP's Delivery Only, Add 3<sup>95</sup> on orders under 35<sup>95</sup> or 20 disk.

## BOOKS RECEIVED

READINGS ON COGNITIVE ERGONOMICS: MIND AND COMPUTERS. G. C. van der Veer, M. J. Tauber, T. R. G. Green, and P. Gorny, eds. New York: Springer-Verlag, 1984; 276 pages, 16.5 by 24 cm, softcover. ISBN 0-387-13394-1, \$13.

THE SECOND BEGINNER'S GUIDE TO PERSONAL COMPUTERS FOR THE BLIND AND VISUALLY IMPAIRED. Diane L. Croft, ed. Boston, MA: National Braille Press, 1984; 214 pages, 21.5 by 28 cm, spiral-bound, no ISBN, \$12.95.

THE SECOND BOOK OF MACHINE LANGUAGE. Richard Mansfield. Greensboro, NC: Compute! Publications, 1984; 464 pages, 15.5 by 23 cm, spiral-bound, ISBN 0-942386-5301, \$14.95. Includes floppy disks.

SING A SONG OF SOFTWARE. Leonard J. Soltzberg. Los Altos, CA: William Kaufmann, 1984; 96 pages, 18.5 by 18.5 cm, hardcover, ISBN 0-86576-073-X, \$9.95.

60 BUSINESS APPLICATIONS PROGRAMS FOR THE TRS-80 MODEL 100 COMPUTER. Terry Kepner and Mark Robinson. Glenview, IL: Scott, Foresman and Co., 1985; 288 pages, 19.5 by 23.5 cm, softcover, ISBN 0-673-18052-2, \$17.95.

THE SMALL BUSINESS COMPUTER. William E. Grieb Jr. New York: Baen Enterprises, 1984; 288 pages, 13.5 by 20.8 cm, softcover, ISBN 0-671-55907-9, \$6.95.

SOFTWARE ENGINEERING CONCEPTS. Richard Fairley. New York: McGraw-Hill, 1985; 384 pages, 17 by 24 cm, hardcover, ISBN 0-07-019902-7, \$34.95.

STATISTICAL PROGRAMS IN BASIC. Ronald D. Schwartz and David T. Basso. Reston, VA: Reston Publishing, 1985; 224 pages, 17.5 by 23.5 cm, softcover, ISBN 0-8359-7106-6, \$16.95.

TK!SOLVER FOR ENGINEERS. Victor E. Wright. Reston, VA: Reston Publishing, 1984; 432 pages, 17.8 by 23.3 cm, softcover, ISBN 0-8359-7711-0, \$19.95.

THE TRS-80 COLOR COMPUTER 2 USER'S GUIDE. Bill Brewer, Mark Brownstein, and Roger C. Sharpe. New York: Macmillan Publishing, 1984; 128 pages, 13.3 by 21 cm, softcover, ISBN 0-02-008820-5, \$5.95.

THE TRS-80 GRAPHICS BOOK. Dennis F. Tanner. New York: Van Nostrand Reinhold, 1984; 256 pages, 21.5 by 28 cm, softcover, ISBN 0-442-28299-0, \$16.45.

TEACH YOUR TRS-80 TO PROGRAM ITSELF! David Busch. Blue Ridge Summit, PA: Tab Books, 1984; 236 pages, 13 by 20.8 cm, softcover, ISBN 0-8306-1798-1, \$11.50.

TEACHING MATHEMATICS AND SCIENCE: PATTERNS OF MICRO-COMPUTER USE. Richard J. Shavelson, John D. Winkler, Cathleen Stasz, Werner Feibel, Abby E. Robyn, and Steven Shaha. Santa Monica, CA: Rand Corp., 1984; 56 pages, 15.3 by 22.8 cm, softcover, ISBN 0-8330-0595-2, \$4.

UNIX FOR PEOPLE. Peter Birns, Patrick Brown, and John C. C. Muster. Englewood Cliffs, NJ: Prentice-Hall, 1985; 560 pages, 18 by 24 cm, hardcover, ISBN 0-13-937459-0, \$29.95.

URBAN TRANSPORTATION NETWORKS. Yosef Sheffi. Englewood Cliffs, NJ: Prentice-Hall, 1985; 416 pages, 15 by 23.5 cm, hardcover, ISBN 0-13-939729-9, \$45.95.

THE USERS GUIDE TO CP/M SYSTEMS. Tony Bove and Cheryl Rhodes. New York: Baen Enterprises, 1984; 318 pages, 13.5 by 21 cm, softcover, ISBN 0-671-55921-4, \$8.95.

USING BASIC ON THE IBM PC. Angela Trombetta and Michael Trombetta. Reading, MA: Addison-Wesley, 1984; 496 pages, 21.5 by 27.8 cm, softcover, ISBN 0-201-06516-9, \$19.95.

USING SYMPHONY. David Paul Ewing and Geoffrey LeBlond. Indianapolis, IN: Que Corporation, 1984; 730 pages, 18.5 by 23.5 cm, softcover, ISBN 0-88022-124-0, \$19.95. ■

## When Your Chips Are Down,

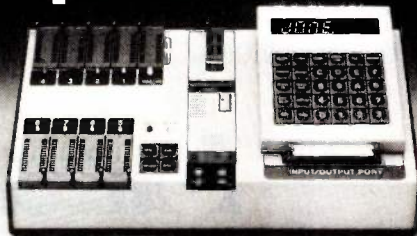

Bank on BYTEK's  
 (E)PROM MultiProgrammer System S15-G  
 With Less Restrictions & a **FREE KEYBOARD**  
 For Only \$995.

Stand Alone or Hook Up to your Terminal,  
 3 Voltage Devices, Simulation Module,  
 Supports Bipolar, PALs, 40 Pin Chips.  
 Also Available: S5 Basic (E)PROM  
 Programmer, \$690. UV Erasers from \$67.

**BYTEK® COMPUTER SYSTEMS CORPORATION**  
 1021 South Rogers Circle, Boca Raton, FL 33431  
**CALL TO ORDER (305) 994-3520, Telex 4310073 MEVBTC**  
 Distributor Inquiries Welcome

# GIVE YOUR PC A \$149 MODEM

**Special Offer**  
To introduce  
PC users to  
**CERMETEK MODEMS**

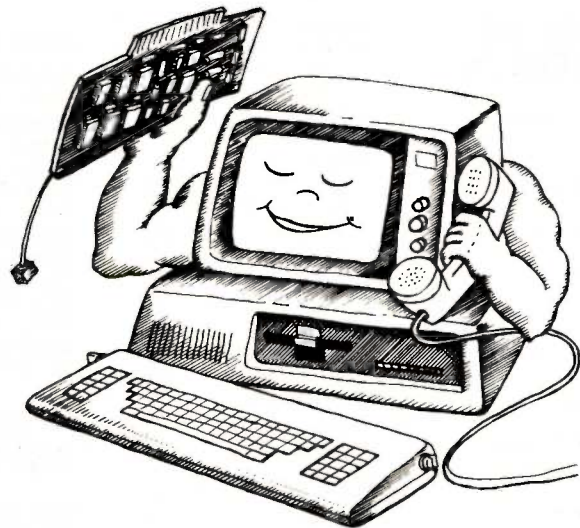

**A 1200 bps modem,  
complete with software!**

The INFO-MATE 212PC modem is a complete data communications solution for your IBM® or compatible computer. Simply plug into any of the computer's expansion slots, boot up MODEM-MATE, communications software included with the modem, and you're ready to communicate with all commonly used 1200 or 300 bps modems.

Cermetek, a pioneer in the modem and modem component business, now offers a complete line of advanced communications products. We want to make our name known with PC users and believe no one could forget this tremendous buy! So, act now! Send in your order today. You'll never get an offer like this again.

\*IBM is a Registered Trademark of International Business Machines

**ORDER TODAY**

Limited to quantities on hand

Dealer inquiries invited.

**Cermetek**  
microelectronics

1308 Borregas Avenue  
Sunnyvale, CA 94088-3565  
(408) 752-5000

## INFO-MATE

### 212 PC Features:

- 1200/300/110 bps, full duplex
- Bell 212A and 103 compatible
- MODEM-MATE software included
- Auto-dial, Auto-answer
- Tone or rotary dialing, auto-selected
- Call progress monitoring
- 8 Diagnostic test modes
- Asynchronous data format
- 1 year limited warranty

### YES! Send me an INFO-MATE 212PC

I have included a check for \$149.00 plus \$4.00 per modem for shipping and handling. (CA residents must add \$9.69 for sales tax.)

Please charge my modem on my:

VISA       MasterCard

Account No. \_\_\_\_\_ Exp. Date \_\_\_\_\_

Signature \_\_\_\_\_

### SEND TO:

Name \_\_\_\_\_

Address \_\_\_\_\_

City \_\_\_\_\_ State \_\_\_\_\_ Zip \_\_\_\_\_

Daytime Phone \_\_\_\_\_

Sorry No COD's. Please allow 4 weeks for delivery.



# Buy with Confidence... Our Record Is Clean!

## IBM/PC SOFTWARE

**Alpha Software**  
Data Base Mgr II ..... \$179  
Electric Desk (Jr) ..... 199

**Arrays, Inc.**  
Home Acct. + ..... \$ 90  
Home Acct. w/  
Tax Advmtg. .... \$139

**Central Point**  
Copy II PC ..... \$34

**CompuView.. See Special**

**Connecticut Software**  
Printer Boss  
w/ Letter Boss ..... \$ 79  
Above w/ Side Kick... 119

**Creative Software**  
Creative Bundle Box  
(Filer, Calc, Writer).... \$109

**Digital Research**  
Concurrent ..... Call  
Fortran 77  
(CP/M or DOS) ..... 299  
Personal Basic (CP/M). 99  
CP/M-86 ..... 49  
Others ..... Call

**Dow Jones**  
Market Analyzer ..... \$229  
Market Manager ..... 189  
Spreadsheet Link ..... 179

**Ecosoft, Inc.**  
Microstat ..... \$239

**Enertronics**  
Energraphics ..... \$219  
w/ Plotter Option ..... 279

**Fastware Thor** ..... \$245

**Financier, Inc.**  
Financier II ..... \$119  
Tax Series ..... 105

**Fox & Geller**  
Grafox ..... \$159  
RGraph ..... 159

**FYI**  
Superfile ..... \$139  
FYI 3000 ..... 259  
Sort Facility ..... 99

**Harvard Software**  
Project Manager ..... \$249

**Lifetree**  
Volkswriter Deluxe ..... \$155  
Volkswriter Scientific... 359

**Living Videotext**  
Think Tank (256K) ..... \$119

**MDBS**  
Knowledge Man ..... \$275

**Menlo Corp.**  
In Search ..... \$279

**Micropro**  
Wordstar ProPak  
(WS, CS, MM, SI) ..... \$275  
Wordstar 2000 ..... 289  
ProPak Plus (WS,  
CS, MM, SI, TM) ..... \$369

**Microrim**  
R-base 4000 ..... \$265  
R-base Clout (V 2.0)... 139  
R-Writer ..... 95  
Prog Interface ..... 259

**Microsoft**  
Flight Simulator II ..... \$ 39  
Project 1.01 ..... 169  
C Comp ..... 319  
Basic Comp ..... 249  
Word 1.15 ..... 229  
MuMath/MuSimp ..... 179

**Microstuf**  
Crosstalk ..... \$ 99

**Morgan Computing**  
Prof Basic ..... \$ 79  
Trace 86 ..... 99

**Multimate (V 3.3)** ..... \$289

**Northwest Analytical**  
Statpak ..... \$365

**Open Systems**  
Acct'g Programs ... ea \$419  
Buy 3 or more ..... ea 399

**Peter Norton Computing**  
Norton Utilities ..... \$ 50

**Peachtree**  
Series 8 Account-  
ing Modules ..... \$359

**Samna Corp.**  
Samna Word III ..... 349

**Satellite Software**  
Word Perfect w/ Sp... \$255

**Software Arts**  
Spotlight ..... \$109

**Software Publishing**  
(PC Jr. Compatible)  
PFS: File, Graph  
Write, Plan ..... ea \$ 89  
PFS: Report ..... 79  
PFS: Access, Proof ..... 59

**Sorcim**  
Supercalc III ..... \$249

**Star Software Systems**  
Acct'g Partner ..... \$219  
Acct'g Partner II ..... 599  
Supersoft ..... Call

**Warner Software**  
(PC Jr. Compatible)  
Desk Organizer ..... \$129

**Westminster Software**  
Pertmaster ..... Call  
... and many more!

## dBASE II CORNER

**Anderson-Bell**  
Abstat ..... \$289

**Ashton-Tate**  
dBase II ..... Call  
dBase III (V 1.1) ..... Call  
Framework (V 1.1) .. Call  
Friday ..... Call

**Fox & Geller**  
dGraph ..... \$159  
Quick Code ..... 159  
Quick Report ..... 159  
dUtil ..... 58

**Sensible Designs**  
dProgrammer ..... \$199

## APPLE SOFTWARE

**Alpha Software**  
Apple-IBM  
Connection ..... \$169  
Typefaces ..... 69

**Arrays, Inc.**  
Home Acct. .... \$ 59  
FCM ..... 79

**BPI** ..... Call

**Broderbund**  
Bank Street Writer ... \$ 45  
Bank Street Speller ... 45  
Others ..... Call

**Cdex**  
All Trng Prog's ..... ea \$ 49

**Digital Research** ..... Call

**Dow Jones**  
Market Analyzer ..... \$229  
Market Manager ..... 189  
Spreadsheet Link ..... 179

**Eduware** ..... Call

**Living Videotext**  
Think Tank ..... \$ 99

**Micropro**  
Pro Pak (WS,  
SS, MM, SI) ..... \$349

**Microsoft** ..... Call

**Peachtree**  
Back to Basics ..... \$149  
PeachPak  
Series 40 or 80 ..... \$229

**Penguin Software** ... Call

**Software Publishing**  
PFS: File, Graph,  
Report ..... ea \$ 79

**Spinnaker** ..... Call

**Xerox Education**  
Sticky Bear Series .. ea \$ 35

## MACINTOSH CORNER SOFTWARE

**Dow Jones**  
Straighttalk ..... 59

**Human Edge**  
Sales Edge ..... \$195  
Mgmt Edge ..... 195

**Intermatrix**  
MacPhone ..... \$159

**Living Videotext**  
Think Tank ..... \$119

**Main St. Software**  
Main St. Filer ..... \$225

**Microsoft**  
MacBasic V 1.01 ... \$ 99  
MacChart ..... 85  
MacWord ..... 139  
MacFile ..... 139

**Monogram**  
Dollars & Sense ..... \$139

**Software Publishing**  
PFS: File, Report .. ea \$ 89

**T/Maker**  
Click Art ..... \$ 39

**Telos Software**  
Filevision ..... \$109

## HARDWARE

**Davong**  
Disk Drives ..... Call

**Kensington Microware**  
Surge Suppressor ..... 45  
Modem ..... \$399

**Memorex**  
3 1/2" Diskettes ..... \$ 49

**Quadram** ..... Call

**Tecmar**  
Disk Drives ..... Call

## CP/M SOFTWARE

All prices below are for 8" standard.

**ATI**  
All Trng Prog's ..... ea \$ 52

**CompuView.. See Special**

**Digital Research**  
DR Assem & Tools  
(80 or 86) ..... \$119  
CP/M 2.2 ..... 99  
C Basic Compiler  
(CB-80) ..... 289  
SPP (86) ..... 149  
Display Mgr 80 ..... 239

## Digital Research (continued)

Display Mgr 86 ..... 279  
Pascal MT+ 80 ..... 199  
Pascal MT+ 86 ..... 349  
CP/M 86 ..... 99  
C Basic Comp 86 ..... 349  
PL/I 86 ..... 399  
Access Mgr 86 ..... 239  
C Compiler/  
Language 86 ..... 199  
Fortran 77 86 ..... 199

**Infocam**  
Deadline ..... \$ 49  
Starcross, Suspended,  
Zork, I, II, III ..... ea 39

**Micro Pro**  
WordStar ..... \$250  
InfoStar ..... 265  
Pro-Pak (WS,  
MM, SI, SS) ..... \$359  
All Others ..... Call

**Microsoft** ..... Call

**Microstuf**  
Crosstalk ..... \$ 99

**Northwest Analytical**  
Statpak ..... \$365

**Oasis**  
Word Plus ..... \$110  
Punctuation & Style... 99

**Supersoft**  
Disk Doctor ..... \$ 74

## ST. PATRICK'S DAY SPECIAL!

### CompuView Products, Inc.

Powerful productivity pkg including:

> Vedit+ - Full screen editor. Multiple-file editing, sort files, arithmetic operations, etc.

> V-Print - Print formatter.

> V-Spell - Spelling corrector w/ 60,000 word dictionary.

Special pricing on 3 packages ..... \$299

### OTHER SPECIALS

Digital Research  
Vedit ..... \$119  
Vedit+ ..... 159  
V-Print ..... 89  
V-Graph ..... 89  
Transyst ..... 89

Prices good thru March 30, 1985



## APPLE/ FRANKLIN BOARDS

<b>ALS</b>	
CP/M Card .....	\$269
Smartem II.....	119
Z-Engine .....	139
<b>CCS</b>	
7711 Asynch Serial....	\$ 99
<b>Microsoft</b>	
Softcard +.....	\$449
Prem Softcard (IIE)....	295
<b>Microtek</b>	
Printer I/F.....	\$ 75
Dumpling-16K .....	169
Dumpling-GX.....	89
<b>Orange Micro</b>	
Grappler + w/ buffer ..	\$175
<b>Prometheus</b>	
Versacard.....	\$159
<b>Videx</b>	
Videoterm VT-602.....	\$249
Ulterm .....	249

## IBM/PC BOARDS

<b>AST Research</b>	
Six Pak + 64K	
(exp 384K, S/P, Clk) ..	\$265
MegaPlus 64K, (Cl/Cal,	
S Port, 512K cap	
w/ Megapak).....	\$269
Extra ports available	
for Megaplus and	
I/O Plus II (Game,	
P or S).....	\$ 40
Megapak 256K up-	
grade for Megaplus. Call	

### BYAD, Inc.

DSII (2/80, 64K	
Ram, Ser Port,	
DR-CP/M 2.2).....	\$495

### Maynard Electronics

Floppy Drive Cntrlr....	\$119
w/ Par Port.....	169
w/ Ser Port.....	179
Sondstar .....	Call

### Orange Micro

Mr. Chips.....	Call
----------------	------

**Orchid Technology**  
the "Orchid Blossom"  
(To 384K, Clk w/ alarm,  
S&P parts, ram disk,  
disk caching, upgrade-  
able to PCNet)..... Call

### Quadram

Quadboard 64K, (exp	
384K, Clk/Cal, S&P	
Ports, Software).....	\$269
<b>Microfazer Stack Printer</b>	
-P/P 8K (exp 512K) ....	\$139
-S/P 8K (exp 64K) .....	149
-S/S 8K (exp 64K) .....	149
<b>Quadlink 64K Memory</b>	
(allows Apple SW to	
run on IBM/PC).....	\$469
Other Products.....	Call

### Tecmar

Graphics Master .....	\$479
Captain's Bd w/64K ...	299
1st Mate.....	259
2nd Mate.....	250
3rd Mate.....	379
Jr. Captain (128K,C,P) ..	329
Jr. 2nd Mate (C,P).....	129

### Xedex/Microlog

Baby Blue.....	\$325
Baby Blue II.....	525

## DISPLAY CARDS

**Frederick/Plan-**  
**tronics** Colorplus... \$399

### Hercules

Graphics Board.....	\$339
Color Board.....	199

### MA Systems

PC Peacock	
Color Board.....	\$249

### Paradise

Display Card	
(clr/monochrome) ..	\$349
Modular/Display....	309

### Quadram

Quadcolor I .....	\$199
Quadcolor II.....	389

### Tecmar

Graphics Master....	\$479
---------------------	-------

## MODEMS

### Hayes

Smartmodem 300.....	\$195
Smartmodem 1200 ....	475
Smartmodem 1200B...	399

### Prometheus

Promodem.....	\$399
---------------	-------

### Quadram

Quadmodem.....	\$529
----------------	-------

### US Robotics

Auto-Dial 300/1200 ...	\$459
S-100 Modem.....	349
Password.....	325

### Zoom Telephonics

Networker w/o SW ...	\$109
----------------------	-------

## MONITORS

### Amdek

300A Amber .....	\$149
310A .....	199
300 Clr .....	265
500 Clr RGB .....	385
600 Clr HR .....	455
700 Clr Ultra HR.....	535

### NEC

JB1201-12" Green....	\$169
JB1260-12" Green ....	119
JCT1216 RGB .....	429

### PGS

HX12 RGB Clr .....	\$489
MAX 12 .....	189
SR12 (690 x 480 Res) ..	639
Doubler Card.....	175

### Quadram

Quachrome .....	\$489
-----------------	-------

### Sanyo

8112 12" HR Green....	\$169
-----------------------	-------

### Taxan

440 .....	\$679
420L.....	499

### Zenith

135 (RGB or comp)....	\$499
136 .....	669
Others.....	Call

## DISK DRIVES

CDC 1800 .....	\$179
----------------	-------

Corvus Hd.....	Call
----------------	------

### Datamac

Truster 10H (for	
Macintosh, Iie, PC) ...	Call

Davong Hd .....	Call
-----------------	------

### I-Omega

Bernoulli Box.....	Call
--------------------	------

### Maynard Electronics

Maynstream: Port-	
able back-up for	
HD System 27 (incl	
1 cntrlr cd).....	\$1495
for System 60 (incl	
1 cntrlr cd).....	\$1695
Cntrlr Cds.....	ea 175
Cartridge 450' ..ea	35
Cartridge 600' ..ea	45

### Mountain, Inc.

FileSafe Combo  
Disk/Tape Pack for  
the IBM PC or XT  
For more info..... Call

### Tall Grass

For Wisconsin customers Call

Tandon TM-100-2.....	\$175
----------------------	-------

## PRINTERS

### C. Itoh Electronics, Inc.

Starwriter	
F10-40P (40cps) .....	\$999
A10-20S (20cps).....	529

### Diablo

630 ECS.....	Call
--------------	------

### Juki Industries

6100.....	\$399
-----------	-------

### NEC

.....	Call
-------	------

### Okidata 82-93.....

Call
------

### Quadram

Quadjet.....	Call
--------------	------

### Star Micronics

Call
------

### Teletex T1014.....

\$399
-------

### Transtar

T-130 P&S .....	\$659
T-315 P - Dot Matrix..	489
T-120 P&S.....	475

... and much more.

## PLOTTERS

### Amdek

DXY-100.....	\$599
Amplot II.....	899

### Enter

Sweet P Six Shooter... Call
-----------------------------

### Houston Instruments Call

### Panasonic

VP6801P Plotter.....	\$1375
----------------------	--------

## DISKETTES

**3M, Maxell, Verbatim**  
**Ultra Magnetics.....** Call

## MISC.

**Alpha-Delta "MACC 8"**  
**Surge Protector .....** \$ 69

### Computer Accessories

Power Directors	
P2 Mtr Base .....	\$109
P12 IBM PC.....	145
P22 Stand Alone..	75

### Electronic

#### Protection Devices

Lemon / EC I.....	\$ 38
Lime / EC II.....	55
Orange / EC IV.....	75

### Hauppauge

8087 w/o sftwe.....	\$149
8087 w/ sftwe.....	255
80287 AT Chip w/o ...	289
Other Products.....	Call

### Kensington

Masterpiece.....	\$109
------------------	-------

### Keytronics

KB 5150 .....	\$169
KB 5151 .....	175
KB 5151 Dvorak .....	175
KB 5150 Jr .....	159
KB 5151 Jr .....	175
KB 5149 (Jr	
Numeric Keypad) ....	89

### Mouse Systems

PC Mouse.....	\$159
---------------	-------

### Touchtone Technology

Touchtone II	
(PC Keypad).....	\$169

### Versa Computing

VersaWriter.....	\$239
------------------	-------

### WICO

Joysticks (Ap).....	\$ 39
---------------------	-------

A variety of complete  
PC compatible systems  
are available at Oryx.  
For assistance in  
determining your needs  
use our technical line.\*  
We will be happy to  
provide full support.

## POLICY:

- ▶ Wisconsin residents add 5% for sales tax.
- ▶ Minimum \$4.00 for shipping, handling and insurance for orders to \$200.
- ▶ For orders over \$200, add 2½% for shipping, handling and insurance.
- ▶ For cash prepayment of orders \$200 or more, add ONLY 2% for shipping, handling and insurance.
- ▶ Foreign — either add 15% handling & shipping (Int'l money order) or inquire.
- ▶ Prices are subject to market fluctuations.
- ▶ All items subject to availability.

## WE WELCOME:

- ▶ Visa, MasterCard and American Express. (No charge for credit cards.)
- ▶ Corporate, government or educational volume purchases, please ask for special accounts desk for additional discount. (1-715-848-1374)
- ▶ COD (Add \$2.00 per box/parcel. Cash or certified check required.)
- ▶ Checks. (Allow 1-2 weeks for clearing.)

## WORKING HOURS:

Monday-Friday 8:30-6:00 • Saturday 10:00-2:00 (Ordering Lines only) • Central Time  
For tech. support, order status and customer service, call (715) 848-1374 (M-F, 8 am to 5 pm)  
Inquiry 420 for Hardware. Inquiry 421 for Software. Inquiry 422 for April Specials.

**ORYX SYSTEMS, INC.**  
CRAFTSMEN OF THE NEW TECHNOLOGY

**1 800 826-1589**

WITHIN WISCONSIN **1 800 472-3535**

425 First Street • P.O. Box 1961  
Wausau, Wisconsin 54401  
INT'L TELEX: 260181 ORYX SYS WAU







# LOAD ASSEMBLER ROUTINES FROM BASIC

BY DOUGLAS F. YRIART

*This method enhances  
the maintainability of your programs*

MICROSOFT BASIC-80, version 5.x for CP/M, includes a number of statements and functions for *calling* machine-language subroutines from BASIC and defining their starting addresses. It does not, however, include a statement for *loading* these subroutines. This article presents a way to automatically assemble and load them. BASIC-80 includes all the tools you need to reserve memory for your subroutines and to load them from the hexadecimal-format file put out by Digital Research's assembler, ASM.COM. The BASIC program doesn't need to know anything about the subroutine except the name of the .HEX file in which it is stored. This file contains all the necessary information for the load, including how much memory is needed.

With this method of loading assembly-language subroutines, you don't need to modify the BASIC program every time you change, add, or delete a few bytes in the assembly-language subroutine. In addition, you can use the same BASIC routine in numerous programs to load assembled subroutines. This method brings significant

benefits in simplicity and maintainability.

## ASSEMBLY-LANGUAGE SUBROUTINE

First, you need an assembly-language subroutine for the BASIC program to call. For example, TEST.ASM (see listing 1) draws an outline of the starship *Enterprise* and then returns control to the calling program. [Editor's note: The unassembled source code for TEST.ASM is available from BYTenet Listings. The telephone number is (603) 924-9820.] Two important points should be considered about the assembly-language subroutine. The first one is its origin. You need to start at as high an address in memory as possible so that the BASIC program will have sufficient room for its execution.

Second, the subroutine must exit through an RET instruction if you want control to return to the BASIC program. After you assemble the subroutine with ASM.COM, you don't need to make it into a machine-code file with LOAD.COM. The BASIC program works with the .HEX file. And, if you try to create a runnable .COM

file, you will need a lot of disk space. LOAD.COM will attempt to create a file the size of the entire memory taken up by the subroutine, including any unused space below the origin.

Table 1 contains TEST.HEX, produced by assembling TEST.ASM. Notice in listing 1 that the program arbitrarily starts at location 9C40 hexadecimal (in the leftmost column on the line with the ORG statement). This same number appears in positions four through seven on the first line of table 1. LOAD.COM uses the first nine positions and the last two positions of each record or line of the .HEX file for its own purposes. The remaining pairs of hexadecimal digits are the instruction, operand, and data bytes you want to load into memory. The first two positions after the colon at

(continued)

Douglas F. Yriart (6805 Melrose Dr., McLean, VA 22101) is Chief of the U.S. Office of Personnel Management's Computer User Center in Washington, DC. He is a Lieutenant Commander in the Naval Reserve and was one of its first two members to be recalled to active duty to attend the resident course at the Naval War College.



Listing 1: TEST.PRN, a listing of the assembled routine, TEST.ASM. This test program is for use in developing a BASIC program to read and POKE the .HEX file of assembly-language routines into memory. This program draws a picture of the starship Enterprise.

```

TEST.ASM version 1.0          1/13/84

by D. F. Yriart — January 1984

Test program for use in developing BASIC program
to read and poke HEX file of assembly-language
routines into memory. This program draws a
picture of the starship Enterprise.

-----
EQUATES

0009 =      pbuff equ    9      ;BDOS print buffer
0005 =      bdos  equ    5      ;location of BDOS
000D =      cr    equ    0dh    ;carriage return
000A =      lf    equ    0ah    ;line feed
0009 =      tab   equ    9      ;horizontal tab

START OF PROGRAM

9C40                org    40000d

start:
9C40 114C9C         lxi    d,data ;point to picture
9C43 CD479C         call   print ;display it
9C46 C9            ret     ;done

print:
9C47 0E09          mvi    c,pbuff ;get proper call in c
9C49 C30500        jmp    bdos ;do it

STORAGE AREA

note: DATA: is made up of any printable or control characters
that will draw or write an appropriate display for user
to look at.

The display is "plain vanilla" characters that can be
found on any CP/M machine; no special screen control
or graphics characters are used for portability.

9C4C 0D0A0A0A0A data: db    cr,lf,lf,lf,lf,lf,lf,lf,lf,lf,lf,lf
9C58 0A0A0A0A      db    lf,lf,lf,lf
9C5C 0909202020    db    tab,tab,' ..... '
9C81 0D0A          db    cr,lf
9C83 0909202020    db    tab,tab,' ..... '
9CA6 270D0A        db    39,cr,lf
9CA9 0909202020    db    tab,tab,' ..... ',39,' / /'
9CC6 0D0A          db    cr,lf
9CC8 0909202020    db    tab,tab,' ...',39,32,39,' ..... / /-'
9CE7 0D0A          db    cr,lf
9CE9 0909202020    db    tab,tab,' ..... ',39
9D07 0D0A0A        db    cr,lf,lf
9D0A 0909202020    db    tab,tab,' THE USS ENTERPRISE --- NCC-1701'
9D2E 0D0A24        db    cr,lf,'$'
9D31                end
    
```

the beginning of each record tell LOAD.COM how many bytes of data are in the record.

**THE BASIC PROGRAM**

Let's look at the BASIC program itself, READASM.BAS (see listing 2 or BYTEnet Listings (603) 924-9820). It accomplishes four tasks:

1. It finds out where to load the assembled subroutine and reserves enough memory for it.
2. It loads the subroutine.
3. It passes control to the subroutine, executing it—if instructed to do so.
4. It restores the subroutine's reserved memory for use by the BASIC program before ending. First, the program must find the top of the TPA (transient program area)—the area of memory available for user programs that is not taken up by CP/M—so that it can restore the full amount of memory to the BASIC program at the end of the run.

Figure 1 provides a memory map of CP/M-80 version 2.2. It is important to notice the number of bytes added to the address of the CCP (console command processor) to find the BDOS (basic disk operating system) and BIOS (basic input/output system) areas. (Addresses are hexadecimal.)

The address of the CP/M BIOS is

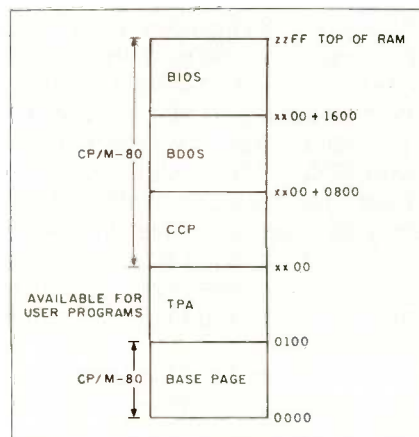

Figure 1: Hexadecimal memory map of CP/M. The xx and zz are dummy arguments representing the most significant byte in an address that changes depending upon memory size.

stored in bytes one and two of the base page (BP). Intel 8080 machine code stores the least significant byte (LSB) of the memory address first, followed in byte two by the most significant byte (MSB). Starting at line 140, the program captures this byte by executing a PEEK at location two. The beginning of the CCP is found by subtracting 16 hexadecimal from the MSB of the BIOS address.

In lines 150-170, the starting address of BDOS, the top of the TPA, is found by doing some *string arithmetic* on the MSB of the CCP address. The VAL() function evaluates strings that start with &H as hexadecimal numbers. The HEX\$( ) function returns a character string containing the hexadecimal digits of the number evaluated. You can use this to build a string composed of &H, the MSB of the CCP address, and an LSB of 00. The VAL() function turns this character string into a number to be assigned to the variable TOP. By adding 800 hexadecimal to TOP, you have the address of the beginning of the TPA. The addresses found in high memory are numbers beyond the range of BASIC-80's valid integers. Therefore, you can't use integer variables to hold addresses in the program.

**RESERVING SUBROUTINE MEMORY**

To reserve memory for the assembled subroutine, you use the CLEAR, ADDRESS statement, which sets aside memory starting at the ADDRESS parameter. The CLEAR statement zeros all numeric variables and sets all string variables to null. Any value that you need to use after clearing memory must be saved in an area unaffected by the CLEAR, so that you can retrieve it later. In this example you need to save the name of the .HEX file, the value of TOP, and the loading address for the subroutine.

Lines 240-300 read the first record of the .HEX file and extract the address needed to load the subroutine. This starting address is in positions four through seven of the record (lines 280-300). Notice the use of string

(continued)

Table 1: TEST.HEX is the hexadecimal-file output from assembling TEST.ASM. The table is annotated to show the various parts of the records. All data is hexadecimal. ("|" is inserted to show parts of the record.)

Data bytes in record	Load address	Data bytes (two characters each)	Overhead
v	v		v
:10 9C40 00114C9CCD479CC90E09C305000D0A0A0A 98			
:10 9C50 000A0A0A0A0A0A0A0A0A0A0A09092020 3A			
:10 9C60 00202020202020202020202020202020 F4			
:10 9C70 00202020C2D2D2D2D2D2D2A2D2D2D2D2D 32			
:10 9C80 002C0D0A090920202020C2D2D2D2D2D2D B8			
:10 9C90 002D2D2D2D2D2D2D202020602D2D2D2020 02			
:10 9CA0 002D2D2D2D2D2D270D0A09092020202060 76			
:10 9CB0 002D2D2D2D2D2D2D2D2D202D2D27202020 0E			
:10 9CC0 002020202F202F0D0A0909202020202020 CD			
:10 9CD0 002020202C2D2D2D2720272D2D2D2D2D2D F5			
:10 9CE0 002D2F202F2D2D2C0D0A09092020202020 7A			
:10 9CF0 002020202020602D2D2D2D2D2D2D2D2D2D A2			
:10 9D00 002D2D2D2D2D2D270D0A09092020202054 37			
:10 9D10 0048452055535320454E54455250524953 BF			
:10 9D20 0045202D2D2D204E43432D313730310D0A 46			
:01 9D30 0024 0E			
:0000000000			
		Overhead (1 byte)	
		"End-of-file" record	

Listing 2: READASM.BAS, a program in Microsoft BASIC-80 to load and run assembly-language routines.

```

10 ' <<< READASM.BAS >>>
20 PRINT
30 PRINT TAB(10);"ASSEMBLY-LANGUAGE FILE LOADER":PRINT
40 '
50 ' Demonstration of method to read and load assembly-
60 ' language programs from a HEX file for calling from
70 ' inside a BASIC-80, version 5.x, program.
80 '
90 ' by D. F. Yriart — January 1984
100 '
110 ' First find the beginning of BIOS — so full memory can
120 ' be restored after the program runs.
130 '
140 BIOS = PEEK(2) ' MSB of BIOS entry address
150 CCP = BIOS - &H16 ' beginning of CCP
160 TOP = VAL("&H" + HEX$(CCP) + "00") ' compute top of
170 TOP = TOP + &H800 ' transient program area
180 PRINT "TOP OF TRANSIENT PROGRAM AREA = ";HEX$(TOP);
190 PRINT " HEX."
200 '
210 ' Open the HEX file and read the first line to get
220 ' starting address for the routine.
230 '
240 HEX.FILE$ = "TEST.HEX" ' name of file to load
250 ON ERROR GOTO 1210 ' trap missing file error
    
```

(continued)



## ASSEMBLER ROUTINES

arithmetic to convert the text *number* to hexadecimal so the program can use it.

In order to protect the information needed after the CLEAR, you must store it somewhere outside of the BASIC program's normal workspace. This program uses the buffer area that CP/M uses for passing commands to the CCP. This buffer area begins at memory location 80 hexadecimal. Lines 370–470 build a 20-character string of data and use POKE to put it into the buffer area. You must store memory addresses as character strings because they are too large to store in a single byte.

Line 520 reserves the memory needed for the subroutine by doing a CLEAR of memory up to 1 byte below the subroutine's starting address. The data is retrieved from the CCP buffer in lines 570–650. Lines 670 and 680 serve the cosmetic function of trimming trailing blanks off the filename.

### SUBROUTINE USAGE

The BASIC program reads the .HEX file one record at a time, captures the data from position 10 to 2 bytes from the end of each record, and uses a POKE to put 1 byte at a time into memory. This is accomplished by two nested WHILE/WEND loops. Two variables control the operation: BYTE contains the next address on which the POKE statement operates, and COUNT is the data-string position of the next byte to be extracted.

The outer loop (lines 790–940) reads records until it encounters the end of the file. Line 830 extracts the data portion of each record for processing by the inner loop (lines 860–920). The inner loop steps through the data string two characters at a time—two hexadecimal digits make up one byte. Line 880 converts the string data into values that can be put into memory with a POKE.

Once the BASIC program has read the last record from the .HEX file, the worst is over. The subroutine is in reserved memory above the BASIC work area. All that remains to be done is to test it out, restore the top of

```

260 OPEN "I",#1,HEX.FILE$
270 IF EOF(1) THEN 1170      ' test for empty file
280 LINE INPUT#1,A$        ' read the first record
290 CLOSE 1
300 START.ADDRESS=VAL("&H"+MID$(A$,4,4))
310 PRINT "Loading will start at ";HEX$(START.ADDRESS);
320 PRINT " hex."
330
340 ' Build a string out of the name of the HEX file, the
350 ' top of TPA address, and the loading address.
360
370 SAVE.IT$=SPACES$(20)
380 MID$(SAVE.IT$,1,12)=HEX.FILE$
390 MID$(SAVE.IT$,13,4)=HEX$(TOP)
400 MID$(SAVE.IT$,17,4)=HEX$(START.ADDRESS)
410
420 ' Store the 20 bytes of data in the CCP buffer at 80h.
430
440 FOR I%= 1 TO 20
450     BYTE=ASC(MID$(SAVE.IT$,I%,1))
460     POKE &H7F+I%,BYTE
470 NEXT I%
480
490 ' Set top of memory available to BASIC 1 byte below
500 ' the loading point. CLEAR zeros all variables.
510
520 CLEAR,(START.ADDRESS-1)
530
540 ' Recover the name of the HEX file, the top of TPA
550 ' address, and the starting address for loading.
560
570 SAVE.IT$=SPACES$(20)
580
590 FOR I%= 1 TO 20
600     MID$(SAVE.IT$,I%,1)=CHR$(PEEK(&H7F+I%))
610 NEXT I%
620
630 HEX.FILE$=MID$(SAVE.IT$,1,12)
640 TOP=VAL("&H"+MID$(SAVE.IT$,13,4))
650 START.ADDRESS=VAL("&H"+MID$(SAVE.IT$,17,4))
660
670 BYTE=INSTR(1,HEX.FILE$,CHR$(32)) ' trim blanks off
680 HEX.FILE$=LEFT$(HEX.FILE$,BYTE-1) ' filename
690
700 ' Read in the HEX file one record at a time. Break it
710 ' into bytes and POKE them into memory.
720
730 PRINT HEX.FILE$;" is being loaded now."
740 OPEN "I",#1,HEX.FILE$
750 BYTE=START.ADDRESS      ' first address to POKE
760
770 ' Begin processing each record here.
780
790 WHILE NOT EOF(1) ' as long as there is another record
800
810 LINE INPUT#1,A$        ' read a record
820
830 A$=MID$(A$,10,LEN(A$)-11) ' just the bytes to POKE
840 COUNT=1                ' byte position in record
850
860 WHILE COUNT < LEN(A$) ' while there are bytes
870     B$=MID$(A$,COUNT,2) ' get a "text" byte
880     VALUE=VAL("&H"+B$) ' convert it to hex

```

```

890          POKE BYTE,VALUE
900          COUNT=COUNT+2 ' increment position
910          BYTE=BYTE+1    ' increment address
920  WEND    ' process another byte
930
940  WEND    ' loop back to process next record
950
960 '      The HEX file has been loaded into memory, now it
970 '      can be CALLED.
980
990 '      *** Real application would go here. ***
1000
1010  CLOSE 1
1020  PRINT BYTE-START.ADDRESS;"Bytes were loaded."
1030  INPUT "DO YOU WANT TO TRY CALLING THE ROUTINE";A$
1040  IF A$="Y" THEN CALL START.ADDRESS ELSE GOTO 1110
1050  PRINT:PRINT
1060  PRINT "!!! IF YOU SEE THIS MESSAGE THINGS PROBABLY ";
1070  PRINT "RAN RIGHT !!!"
1080
1090 '      Restore top of memory and exit;
1100
1110  CLEAR, TOP
1120  PRINT TAB(10);"**** END OF DEMO ****"
1130  END
1140
1150 '      Error traps
1160
1170  PRINT "THE FILE IS EMPTY"
1180  CLOSE 1
1190  END
1200 '      Missing file
1210  IF ERR <> 53 THEN 1280
1220  PRINT HEX.FILE$;" IS NOT ON THE LOGGED DRIVE."
1230  PRINT "**** READASM SAYS GOODBYE ****"
1240  IF TOP = 0 THEN END
1250  CLEAR, TOP
1260  END
1270 '      All other errors
1280  PRINT "ERROR #";ERR;"OCCURRED IN LINE";ERL
1290  PRINT "**** READASM CAN'T CONTINUE ****"
1300  IF TOP = 0 THEN END
1310  CLEAR, TOP
1320  END
    
```

BASIC memory to its original contents, and exit gracefully. Line 1040 will call the subroutine. Whether you call the subroutine or not, the program exits via line 1110, which clears memory back up to the bottom of the BDOS. (You may come up a few bytes short since we calculated the address using only the MSB.)

The error traps beginning at line 1170 tell you when something goes wrong. But more important, they restore the top of memory before you exit the program.

**SUMMARY**

This article discusses an automated method for loading an assembly-language subroutine into memory where it can be called by a BASIC program, despite the fact that BASIC-80 version 5.x has no specific command to do this. The benefits of this method are simplicity and maintainability for both the calling BASIC program and the assembly-language subroutine. The BASIC program doesn't need to know anything about the subroutine until run time, when it reads the pertinent information from the assembled .HEX file. This provides you with the ability to modify the assembly-language subroutine without affecting the BASIC program that calls it. ■

**REFERENCES**

1. Hogan, Thom. *Osborne CP/M Users Guide*, 2nd ed. Berkeley, CA: Osborne/McGraw-Hill, 1982.

## ATTENTION : OKIDATA : OWNERS!

### USE YOUR PRINTER TO ITS FULLEST WITH MARVEL PRINT™!

**MARVEL PRINT FEATURES:**

- Proportional Spacing of letter quality text—(justifies right margins).
- Enables you to create graphics—even in the middle of text.
- Lets you create your own character sets.
- Allows you to backspace.
- Includes a powerful Label Printing Program.
- Uses only one character for common codes:

SUBSCRIPT	EMPHASIZED
SUPERSCRIPIT	DOUBLE WIDTH
UNDERLINE	PICA
ENHANCED	ELITE
DATA MODE	CONDENSED



**DEMO DISKETTE** OKIDATA L1111  
\$2.00 Refundable with purchase

Also available from Marvel Software by Popular Demand:  
**Character Sets:** Italics • Script • Science & Math Symbols • Hebrew • Russian • Arabic • Greek • Foreign Language Marks  
**Character Clone Set:** Allows you to take characters from different sets & combine them for simultaneous use.

Marvel Print only .....	<b>\$70</b>
Marvel Print with any 1 character set .....	<b>\$85</b>
Marvel Print with any 2 character sets .....	<b>\$90</b>
Character Clone set .....	<b>\$10</b>

Works with Apple, CP/M-80, PC-DOS, MS-DOS. **State System.** Visa, American Express, Mastercard welcome. Phone orders accepted or Send check or M.O. to:

**MARVEL SOFTWARE**  
1922 Ave. N, B'klyn, N.Y. 11230, (718) 336-2323

**MARVEL PRINT**—the new user-friendly program that generates ALL the features of the Okidata 92 & 93 printers using ANY text-producing program (word processor, spread sheet, data base).

We sell Okidata 92 & 93 printers bundled with Marvel Print hardware at discount prices. Call or write for more information. Dealers welcome. Okidata is a trademark of the Okidata Corp.



**S**TAR'S NEW  
PRINTERS WORK  
20% FASTER.  
COST 20% LESS. ARE  
100% CERTAIN TO  
CHANGE YOUR MIND  
ABOUT PRINTERS.

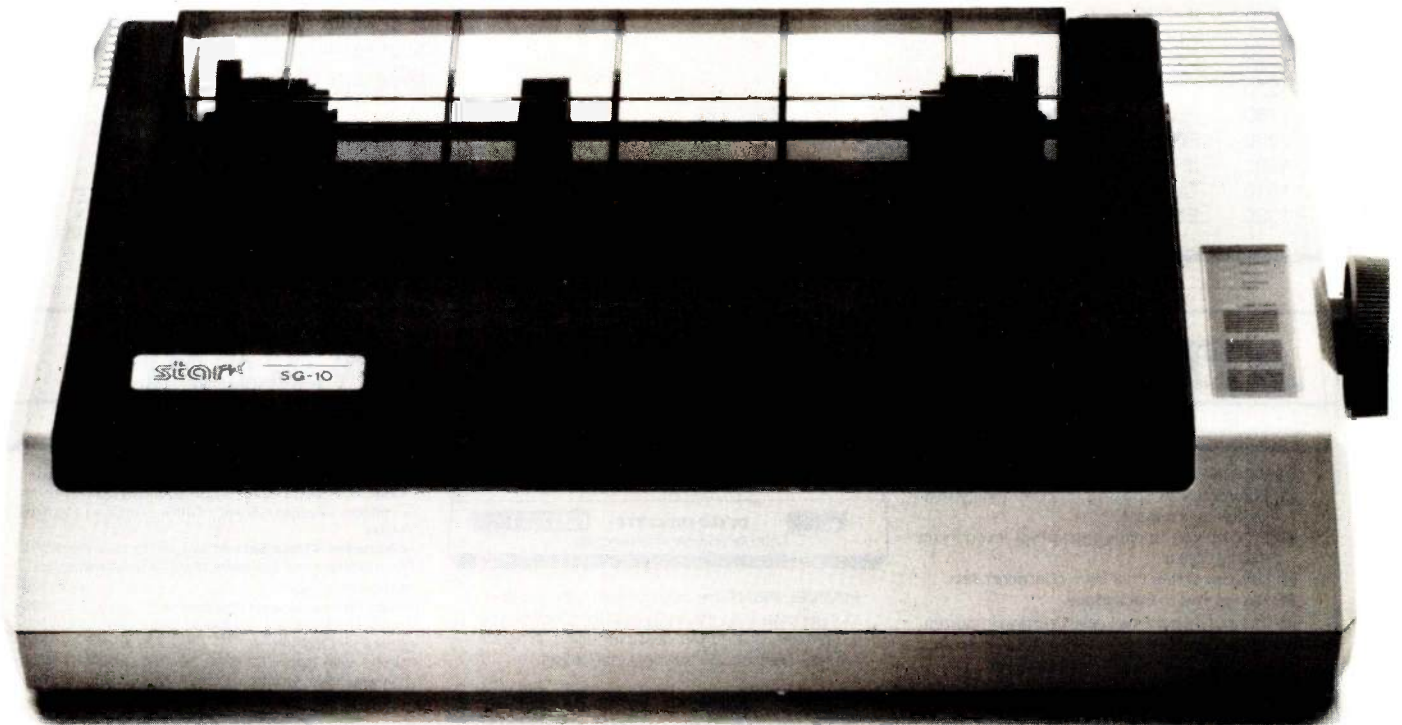

**This new dual-mode SG-10 is only \$299.**

# N

o printer could be more appealing than one you design yourself.

And, in effect, that's what you've done.

The new "S" series printers from Star Micronics have been designed not to our specifications, but to yours. With values that confound our accountants but will make great sense to you.

These printers are faster than ever. More compatible and reliable. With more added in and fewer add-ons.

And yet they cost less.

Don't try to figure it out. Just enjoy.

## NLQ IS 1 OF 2

Because we've increased our printing throughput by 20%, you can now finish 6 pages in the time it used to take to print 5. And even though we've upped our speed, we've kept up our quality.

In fact, on three of our new models, both draft and near-letter-quality are standard (no extra charge). A fourth model, the SB-10, prints draft and letter-quality standard (again, not extra).

So now, with just one printer, you're ready for data processing and word processing. That's like owning two printers for the price of just one.

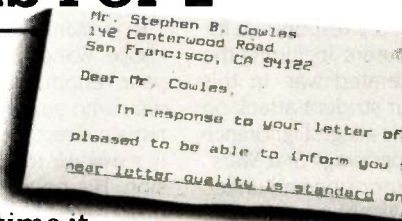

## GET ON LINE BY JUST PLUGGING IN

The new Star "S" series printers are fully compatible with even the most fickle of personal computers.

And they're especially friendly with IBM®-PC, Apple®, Commodore®, and all compatibles.



In most cases, hooking up is no more complicated than putting a square peg in a square hole. But it's a lot more rewarding.

## READY FOR ANY SOFTWARE

The new "S" series printers make printing as easy as 1-2-3.™ Which is just one example of the many spreadsheet programs they're ready for.

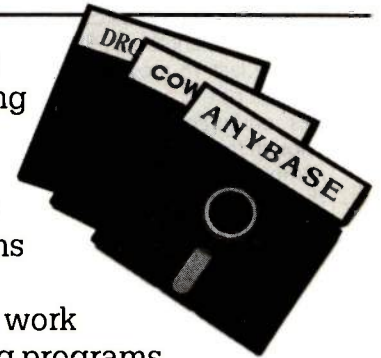

The new Stars can work with word processing programs like WordStar.® Educational software like Dr. Logo.™ And even the new integrated formats like Framework™ and Symphony.™

So Star printers match hardware to software without disk-driving you crazy.

They handle many functions faster. They're more compatible. Less expensive. More reliable. And have a full year warranty. "S" series printers have been designed with so many of your needs in mind, it's as if you'd done it yourself.

And what a great job you did.

For a free demonstration, visit your local Star dealer.



SR-10 prints 200 cps for only \$649.

SD-10 types draft and NLQ, just \$449.

SR-15 includes 16K memory for spreadsheets, \$799.

# star

THE POWER BEHIND THE PRINTED WORD®

200 Park Avenue, New York, NY 10166

Chicago, IL (312) 773-3717 • Boston, MA (617) 329-8560  
Irvine, CA (714) 586-8850

Prices shown are manufacturer's suggested retail prices.



(continued from page 32)

sophistication in the manner that past Apple customers have. Hence, there is no reason to widely disseminate technical information to the customers.

The dominant theory in the industry during the last 18 months seems to be that the age of the hacker is over. I belong to this endangered species. I make just enough from software sales to pay for my computer habit. It seems to me that rather than my time being over, I am more important to Apple than at any time in the past. I have bought two Apple IIs in the last six months (the IIc personally and a IIe at work). I am often asked to advise people about what computer to buy.

In the past I have been able to recommend Apple because there was so little likelihood that my friends could possibly outgrow the company. They might become more accomplished hackers than I am, but they could not plumb the depths or exhaust the expansibility of their Apples. Every change in Apple policy that I have observed during the past year has made this less true.

JOHN R. RAINES, M.D.  
St. Paul, MN

**WHO PAYS FOR COPY PROTECTION?**

As a composer of music that incorporates much synthesizer work, I have seen the development of MIDI as a real and practical boon. In my own studio I now use a microcomputer with a Passport MIDI interface (Apple-compatible version) to control Yamaha synthesizers (DX-9 and RX-15).

Frankly, the available software, and most specifically its copy protection, is working against its own benefits.

I use MIDI/4 from Passport as a sequence recorder and player. I would like to use DX-Pro from Yamaha (yes, it works after a fashion on the DX-9) as a patch editor and recorder. A session with both the other day proved unmanageable. Since both are severely copy-protected, to use one right after the other requires a cold boot for each. This takes time and requires powering down the computer. It seems to me that in the real, working world of synthesis it would be sensible if both programs could be copied onto the same disk (or hard drive or RAM disk) and accessed back and forth. Well, copy protection renders this impossible. The Passport software, by the way, comes with a backup disk. The DX-Pro from Yamaha does not! Disks do not hold up well to the rigors of travel, which means that one

blown sector and . . .

There is a legitimate need for protecting the interests of software writers and vendors. However, if this occurs at the expense of the end users in the form of diminished usefulness, it is protecting the interests of no one.

I am frankly not interested in generating a long and philosophical debate on these issues. I am interested in getting my system up and running efficiently so I can get on with making music.

MICHAEL W. GILBERT  
Amherst, MA

**COMPUTER VS. HUMAN RESPONSIBILITY**

The January BYTE editorial ("Autonomous Weapons and Human Responsibility" by Phil Lemmons, page 6) makes the important point that humans are responsible for the acts of their computers, including the act of computer-generated war. In this context, however, your strident attack on Walter Mondale—for his alleged ignorance or demagoguery in opposing "Star Wars" technology—is both surprising and unfair.

Because nuclear weapons in orbit around the earth could more rapidly reach their targets, the time for an offensive or defensive response would be reduced to a very few minutes. (Even if the initial space system is defensive in nature, it is naive to think that the inevitable countermeasure would not be an offensively oriented one.) The potential, then, for contemporaneous human intervention in the response decision—let alone for the somber human reflection most of us would wish for such a fateful decision—is effectively eliminated. In other words, and disregarding the responsibility issue for the moment, the act of making nuclear war from space would of necessity be relegated to computers.

None of this is to say that the computer would be "responsible" for the resulting devastation, a nuclear villain we should fear and abhor. As you stated, "Computers follow sequences of human instructions." But is it ignorant or demagogic to suggest that the nuclear hair trigger not be split to the point where only a computer has the time to effect, or avoid, our annihilation? I think not, and I think this was Mr. Mondale's well-taken point.

At the risk of sounding anticomputer, which I earnestly am not, a further point must be made about the reliability of computers. Computers, including lovingly attended micros and NASA's multi-million-dollar systems, do, at times, screw up.

Chips do fail and programs do have bugs. Sometimes the things just shut down; other times, to our horror, they continue to run and produce spurious or confounding results. Sure, humans (designers or engineers or programmers or manufacturers or users) are again responsible. And certainly the politician who, knowing these unfortunate facts of technological life, consigned our fate to such systems could not deny culpability. But, again, is it ignorant or demagogic to oppose entrusting civilization to these all too fragile machines?

I agree that BYTE is not the place, and that neither I nor most BYTE readers are the people, to discuss the technical merits of the "Star Wars" proposal. But, similarly, I don't think BYTE is the place to dismiss concerns about this proposal as senseless computer phobia or worse.

It is ironic and unfortunate that you chose Walter Mondale as the object of your venom. For, indeed, it was Mr. Mondale who suggested that a human being remain directly, consciously, and personally responsible for the ultimate human decision. His notion that President Reagan's proposal, which would necessitate that this decision be made by a computer, endangers us is neither frivolous nor an abdication of human responsibility for computer actions. But it is both presumptuous and irresponsible when we, as computer devotees, assume a shrilly defensive posture that fails to acknowledge the limits of our technology or knowledge.

SEAN BLECK  
New York, NY

Regarding your January editorial, I believe you have not given Mr. Mondale enough credit.

To make the Strategic Defense Initiative work, enemy missiles would have to be struck within the first five minutes of their launch, thus not leaving enough time to have the President decide whether or not to respond, for reasons I will be happy to detail at your request.

I for one am not ready to change the decision-making process on whether to start shooting at the Russians from a Conference of the President, SAC, and a Congressional Committee to a preprogrammed computer.

How can aerospace programmers "assume responsibility" for the decision that only the President of the United States should make? Even if they're "willing to," I for one am not willing to give them that responsibility, even if you are.

Further, the most brilliant programmers

working 1000 years could not possibly foresee all possible scenarios. Only human judgment has the flexibility to deal with all possible new original situations, at least at the present. A computer may be programmed by human beings, but a computer is *not* a human being. Human beings should use computers to aid calculation, information gathering, and for advice.

They should never turn control of their destiny over to computers, however, no matter how well programmed. In any event, we have not yet amended the Constitution to give aerospace-company programmers and computers the power to declare or initiate war. I for one am not in favor of any move to change it to let such happen.

DON SLAUGHTER  
Seattle, WA

A very big WELL DONE to Phil Lemmons for his editorial on "Autonomous Weapons and Human Responsibility."

Phil pointed out that we must take responsibility for our decisions, even if it *appears* that a computer made the decision for us. This is an important lesson for all of us. We must not avoid responsibility for our decisions.

Beyond the specific issue addressed, I was delighted to see BYTE addressing moral and social issues as well as technical ones. During this past century, our technology has leapt far ahead of our morality. Vigorous dialogue in our journals is one good way to help close this gap.

BYRON WEBER-BECKER  
Goshen, IN

Having heard Walter Mondale use the word "computer" in an attack on President Reagan, you snapped back a reply without having thought through Mondale's complaint. When liberals do this, it is called a "knee-jerk reaction."

Mondale's point was that for Reagan's "Star Wars" defense plan to work, incoming missiles would have to be shot down before they spew their multiple, independently targeted (MIRVed) nuclear bombs. Thus, there would be only a few minutes between detection, identification, and confirmation of the launch and the time when the decision to attack should be made or not. It would not be feasible to get this information to the president (*any* president) and have her analyze it and make an informed decision in time. The decision would have to be left up to the computers.

Why is this a problem? Not because computers can make mistakes. Perish the thought. (Has a computer really never

made a mistake? Are electronic components really infallible?) Rather, human programmers make mistakes. The problem Mondale was pointing to about "Star Wars" (only one of many problems!) is that *programmed* computers make mistakes. Only a computer fanatic would have taken this as an attack on computer hardware as opposed to software.

The mistake you have made is similar to

the following: Jane says, "We ought to have tough drunk-driving laws because weaving, lane-hopping cars can do terrible damage." Phyllis (editor of a major automobile magazine) replies, "There she goes again. Cars aren't malevolent. It's the people driving the cars that are at fault." But we all know that. Phyllis has simply missed the point.

(continued)

## Faster CAD Input

The GTCO DIGI-PAD is a fast tracing device, a function the mouse can't perform at all. It's an absolute screen pointing device for direct cursor control. It can also provide direct, simple menu selection. The GTCO DIGI-PAD is a digitizer tablet in sizes including 12"x 12", 11"x 17", 20"x 20", 24"x 36", 36"x 48" and 42"x 60".

The DIGI-PAD is easily interfaced to PCs and is compatible with most PC/CAD software, such as AutoCAD™ and CADPLAN™.

The digitizer surpasses all other input devices for tracing and pointing and menuing. GTCO digitizers use patented electromagnetic technology for years of silent, maintenance-free operation.

Ask your dealer about the GTCO DIGI-PAD.

® DIGI-PAD and Micro DIGI-PAD are registered trademarks of GTCO Corporation.  
™ AutoCAD is a trademark of Autodesk Inc.  
™ CADPLAN is a trademark of Personal CAD Systems, Inc.

With the **GTCO DIGI-PAD®**

Micro DIGI-PAD™ for small applications.

DIGI-PAD for large digitizing tasks.

**GTCO Corporation**  
1056 First Street • Rockville, MD 20850  
(301) 279-9550



Finally, it is worth noting that the mistake Phil Lemmons and Phyllis have made is the same mistake made by those who say "Guns don't kill people; people kill people" as if that were disputed by those in favor of rational gun-control laws.

DAVID WEINBERGER  
Assistant Professor of Philosophy  
Chair, Peace and Conflict  
Resolution Studies  
Stockton State College  
Pomona, NJ

*Phil Lemmons replies:*

*It makes little sense to argue against orbital weapons on the ground that they would have to be controlled by computers. It makes much sense to reject orbital weapons because they put terrible destructive power only minutes from our cities. No control, human or artificial, could make us feel comfortable with devastation constantly poised above. Those who oppose orbital weapons should concentrate on resisting the weapons rather than the control system.*

*Regardless of the components of the control system, humans would bear responsibility, including responsibility for computer malfunctions.*

### TRAVESTY IN B

My colleagues and I were interested to see the article "A Travesty Generator for Micros" by Hugh Kenner and Joseph O'Rourke (November 1984, page 129), since we've had a similar program running here for a couple of years, written not in Pascal but in the new language B. The interesting thing about the B version of the program is that it is only 24 lines long, compared with the 284 lines of Pascal. Consequently, we thought that other BYTE readers might like to see our version.

B is a very simple language, about as easy to learn as BASIC, but the big difference is that B has very powerful data types, and it's thanks to these that programming in B is so easy.

To understand the program you have to know a little about these data types: B has

texts, which are strings of characters. For instance, "hello" is a text. There is no character data type; you just use a text of length one, such as "a" or "b". There are operators on texts:  $a \wedge b$  joins the two texts  $a$  and  $b$ ,  $a \wedge n$  repeats the text  $a$   $n$  times, and  $a@n$  gives the tail of text  $a$  starting at the  $n$ th character.

B also has lists, which are sorted lists of elements. For instance, {"B"; "Pascal"; "Smalltalk"} is a list of texts, as is {"a"; "b"; "c"}, and {"z"}. {} is the empty list. You can insert a new element  $e$  in a list  $\lambda$  with  $\text{INSERT } e \text{ IN } \lambda$ . Although lists are kept sorted (alphabetically in the case of texts), the program doesn't use this fact.

The program deals with what the original article calls  $n$ -grams; that is, groups of  $n$  letters from a text. The B program works by associating with each group of  $n-1$  letters a list of letters that may follow it. Thus, when dealing with trigrams for the sentence "Nonsense imitation can be disconcerting" for the letters "on" you get the list {""; "c"; "s"}, and for "ns" you get {"e"; "e"}. This association is done using the table data type, which is a generalization of arrays; in most other languages, you may index only arrays with integers (or similar), while in B you can use any type. In this program a table called *followers* is used, indexed by texts and giving lists of characters, so that with the above sentence you get  $\text{followers}["ns"] = \{"e"; "e"\}$  for instance. You can find out which indexes have been used for a table; "keys followers" gives the list of such indexes. {} is also the empty table.

Another interesting feature of the program is that it is trivial to modify so that it works with *words* instead of characters. For instance, UPDATE would remain identical.

B is an interactive language, and there are implementations for machines with UNIX available at the cost of the media, and shortly for the IBM PC. Anyone who would like to know more about B or its implementations is welcome to write to me.

STEVEN PEMBERTON  
B Group  
CWI  
Postbus 4079  
1009 AB Amsterdam  
The Netherlands

Listing 1: A Travesty program in B. The four lines at the bottom were produced from "Mary had a little lamb" as input, using 1-, 2-, 3-, and 4-grams, respectively.

```
HOWTO TRAVESTY document USING n GRAMS:
  PUT ""^(n-1), {} IN gram, followers
  FOR line IN document: ANALYSE \ Analyse each line in turn
  FOR count IN {1..10}: GENERATE \ 10 lines of imitation
ANALYSE: \ Analyse one line
  FOR char IN line:
    UPDATE followers FOR gram WITH char
    APPEND char TO gram
  UPDATE followers FOR gram WITH "" \ Treat line end as space
  APPEND "" TO gram
GENERATE: \ Generate one line
  PUT 0 IN length
  CHOOSE gram FROM keys followers \ Choose a random start
  WHILE gram in keys followers AND (length < 50 OR char < > "");
    CHOOSE char FROM followers[gram]
    WRITE char
    PUT length + 1 IN length
    APPEND char TO gram
  WRITE / \ Write a newline

HOWTO UPDATE followers FOR gram WITH char:
  IF gram not in keys followers: PUT {} IN followers[gram]
  INSERT char IN followers[gram]

HOWTO APPEND char TO gram:
  PUT (gram char)@2 IN gram
```

- 1: nhwaso ldm r tvncd vetsvaen ryam wnMhuuaiaa lryulitlab
- 2: evere Mad ad ts go Mamb snfs s s ad lamb flits it
- 3: ry hat Marywhery was was fleece that lamb ittleece
- 4: te as snow and everywhere that lamb was white as white

### CIRCUIT-BOARD CATASTROPHE

I have become the victim of an event, totally beyond my control, that has nothing less than shut down my computer services.

## LETTERS

I own an LNW Model II microcomputer—a powerful work-alike of the TRS-80 Models 1 and 3. In late June of this year my expansion board developed a problem, rendering the facilities on the board useless. This system-expansion circuit board includes half of the system memory, serial and parallel interfaces, floppy-disk controller, and clock circuits. Because the problem (I suspected the floppy-disk controller) developed and was reported less than one year after purchase, the computer was still covered by warranty.

On July 7, 1984, after telephoning LNW Research, I was given a "return authorization number." As instructed by Technical Services at LNW Research, removing the factory-built expansion board from the computer unit would not void my warranty. I then removed the circuit board, as instructed, and had it packaged and shipped to LNW Research via United Parcel Service. The "return authorization number" was clearly labeled on the package and also taped directly onto the circuit board.

After about 10 days and several follow-up telephone calls, LNW finally acknowl-

edged receipt of my circuit board. I made repeated telephone inquiries (never receiving a reply) after that to check on the progress of the repair. Finally, after amassing a rather large telephone bill, about 2½ weeks ago I was told, rather unwillingly, that my expansion board had not been touched. I was also told that many of LNW's repair technicians had been on vacation and that repairs on units under warranty were backlogged. I was asked to call back in two to three weeks, or if I wanted my circuit board sent to Wilson Technical Services. Mr. Wilson, I was told, had formerly been employed by LNW Research and was doing part of LNW's warranty repair work. I elected to leave the circuit board with LNW.

After a two-week wait, I tried contacting LNW by telephone again but received no answer. I then called Wilson Technical Services and was told that LNW had gone out of business! All of LNW's warranty work, I was told, had been turned over to Wilson Technical Services. My expansion board, however, was not on the list of units turned over to them. Wilson Technical Services

said that it would check further. I telephoned Wilson Technical Services again, and the woman to whom I spoke before confirmed that my expansion board was not on the list of units turned over to Wilson Technical Services.

No person seems to know the present location of my essential and relatively expensive circuit board. I, therefore, have found it necessary to contact the Attorney General's office of the State of California to begin proceedings against Wilson Technical Services and LNW Research (if it can be located). This is in addition to contacting all magazines and users groups that I can think of. I am also contacting the Better Business Bureau and the Chamber of Commerce of Tustin, California.

I am not the only LNW 80 computer owner involved in this aggravating situation. Wilson Technical Services informed me that I am only one of several in the same predicament. So here I sit, out of business, awaiting the outcome of due process.

JEFFREY W. COX  
New Albany, IN

# BYTE magazine back issues for sale

	1976	1977	1978	1979	1980	1981	1982	1983	1984	1985
Jan.				\$2.75	\$3.25	\$3.25		\$3.70	\$4.25	\$4.25
Feb.			\$2.75	\$2.75	\$3.25	\$3.25	\$3.70	\$3.70	\$4.25	\$4.25
March			\$2.75		\$3.25		\$3.70	\$3.70	\$4.25	\$4.25
April			\$2.75	\$2.75	\$3.25	\$3.25	\$3.70	\$3.70	\$4.25	
May		\$2.00	\$2.75	\$2.75	\$3.25		\$3.70	\$3.70	\$4.25	
June		\$2.00	\$2.75	\$2.75	\$3.25		\$3.70	\$3.70	\$4.25	
July	\$2.00	\$2.00	\$2.75	\$2.75	\$3.25		\$3.70	\$4.25	\$4.25	
Aug.		\$2.00	\$2.75	\$2.75		\$3.25	\$3.70	\$4.25	\$4.25	
Sept.		\$2.75	\$2.75	\$2.75	\$3.25		\$3.70	\$4.25	\$4.25	
Oct.			\$2.75	\$2.75	\$3.25	\$3.25	\$3.70	\$4.25	\$4.25	
Nov.				\$3.25		\$3.25	\$3.70	\$4.25	\$4.25	
Dec.		\$2.75	\$2.75	\$3.25	\$3.25	\$3.25	\$3.70	\$4.25	\$4.25	

Special BYTE Guide to IBM PC's — \$4.75

**Circle and send requests with payments to:**  
**BYTE Back Issues**  
**P.O. Box 328**  
**Hancock, NH 03449**

Prices include postage in the US. Please add \$.50 per copy for Canada and Mexico; and \$2.00 per copy to foreign countries (surface delivery).

Check enclosed

Payments from foreign countries must be made in US funds payable at a US bank.

VISA

MasterCard

Card # \_\_\_\_\_

Exp. \_\_\_\_\_

Signature \_\_\_\_\_

Please allow 4 weeks for domestic delivery and 12 weeks for foreign delivery.

**NAME** \_\_\_\_\_

**ADDRESS** \_\_\_\_\_

**CITY** \_\_\_\_\_

**STATE** \_\_\_\_\_ **ZIP** \_\_\_\_\_



PERIPHERALS

**Data-Compression Unit**

The Accelerator Series 31 asynchronous data-compression unit from Telebyte can be installed in existing networks. The Accelerator provides 3-to-1 data acceleration and supports synchronous and asynchronous modems. It can handle terminal data rates up to 9600 bits per second and modem data rates up to 2400 bps.

During operation, encoded bit strings are transmitted between Accelerator units using a modified X.25 protocol. This method limits data errors and increases data security. Also, you can improve security by assigning a four-digit Network Security Code to each Accelerator in the network.

The Accelerator's front

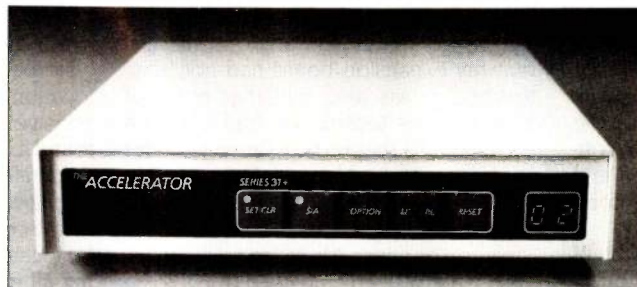

The Accelerator data-compression unit.

panel includes touch-sensitive keys, status lamps, and display digits so you can program permanent options from the front panel. The unit contains no internal DIP switches or jumpers.

Prices for the Accelerator Series 31 products range from \$695 for a unit with a data-compression ratio of 2

to 1 and a modem data rate of 1200 bps to \$1095 for the maximum configuration with a data-compression ratio of 3 to 1 and a modem data rate of 2400 bps. For more details, contact Telebyte Corp., 215 Oak St., Natick, MA 01760. (617) 653-3995. Inquiry 615.

**Mac Hard-Disk Drives**

Davong supplies multiple-volume hard-disk drives for the Macintosh with four amounts of storage: 10, 21, 32, and 43 megabytes. Mac Disks are partitioned into two volumes

and initialized when shipped. Each disk-drive system features Davong's Volume Manager software.

Average Mac Disk access time is 100 milliseconds with the 10- and 21-mega-

byte systems and 40 milliseconds with the 32- and 43-megabyte models. Mac Disk connects to either RS-422 port on the Macintosh.

The Volume Manager program lets you add, delete, and activate volumes. It also can gather free space on Mac Disk so you can compress space to create an additional volume. This release of the software lets you connect Mac Disk to the Macintosh's modem or printer port for use in telecommunications.

Prices for the Mac Disk line depend on amount of storage: \$1950 for 10 megabytes, \$2795 for 21 megabytes, \$3395 for 32 megabytes, and \$3995 for 43 megabytes. For complete details, contact Davong Systems Inc., 217 Humboldt Court, Sunnyvale, CA 94089. (408) 734-4900. Inquiry 617.

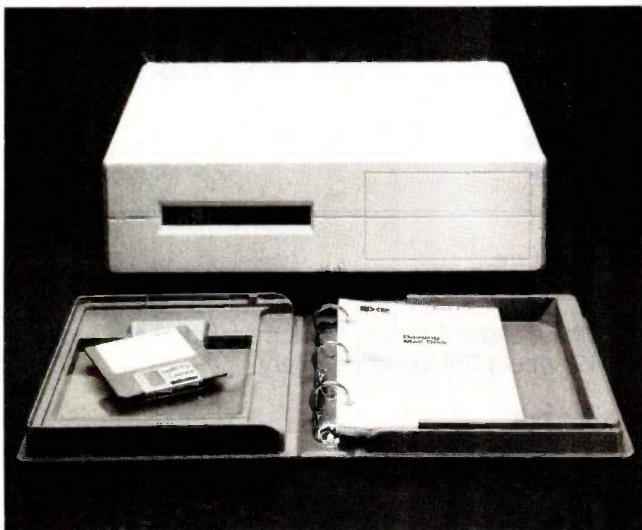

Davong's Mac Disk hard-disk drive.

**Hard-Disk System for the AT**

Internal hard-disk drives specially designed for the IBM PC AT are available in 20-, 33-, and 117-megabyte models from PC's Limited. The disk-drive systems are compatible with DOS 3.0 and 3.1.

The full-height 5¼-inch hard-disk drives run off the IBM-installed PC AT controller. The units come complete with the necessary cables and mounting hardware, and they install easily, dropping directly into the existing PC AT box.

Prices for the hard-disk drives are \$795 for the 20-megabyte model, \$1195 for 33 megabytes, and \$3995 for 117 megabytes. For further information, contact PC's Ltd., 7801 North Lamar #E-200, Austin, TX 78752. (512) 452-0323. Inquiry 616.

**PCjr Numeric Data-Entry Pad**

Key Tronic's numeric data-entry pad for the IBM PCjr includes all mathematical function keys. It also features cursor-control, Tab, Backspace, and Enter keys. The user can convert the numeric pad to the function mode without returning to the PCjr keyboard. The keypad facilitates efficient data entry for number-intensive applications such as spreadsheets and accounting systems.

Suggested manufacturer's retail price for the IBM PCjr numeric keypad (model KB 5149jr) is \$99.95. For more information, contact Key Tronic Corp., POB 14687, Spokane, WA 99214, (800) 262-6006; in Washington, (509) 928-8000. Inquiry 618.

PERIPHERALS

**3Server Network Server**

**A** dedicated multifunction network server is available from 3Com. You can use 3Server with 3Com's Ethernet-based EtherSeries network products to combine personal computers and host systems in a local-area network (LAN). 3Server also supports communications over telephone lines for electronic mail and direct communication with

IBM mainframes using SNA protocols.

The 3Server can accommodate up to 50 individuals in a network. It uses the Intel 80186 and the 82586 Ethernet controller with a 36-megabyte (formatted capacity) fixed-disk drive.

You can add a tape backup unit of 60 megabytes to the 3Server. You can also use up to six external disk-

drive modules to expand disk storage to more than 250 megabytes per 3Server.

Suggested retail price for the 3Server is \$7495. Add-on 36-megabyte disk drives cost \$3995 each, and the 60-megabyte tape backup unit costs \$2995. A \$995 384K-byte memory option for expansion of disk cache will bring total memory to 896K bytes.

EtherShare, a 3Server software package that provides shared disk capabilities, costs \$695. EtherPrint, a shared printing program, sells for \$395, and EtherMail gives you electronic-mail capability for \$995. Contact 3Com Corp., 1365 Shorebird Way, POB 7390, Mountain View, CA 94039, (415) 961-9602. Inquiry **619**.

ADD-INS

**Memory Upgrade for the Mac**

**M**icroGraphic Images has released the MegaMac, a memory upgrade for Apple's Macintosh. MegaMac hardware provides 1024K bytes of memory, partitioned into two sections: 512K bytes of core memory and 512K bytes used as a RAM disk.

Reportedly, the MegaRAM software package sold with the upgrade board lets you load any file or application program from the RAM disk into the core memory three to six times faster than from

a disk drive.

The suggested retail price for the MegaMac upgrade board is \$1395. (You must return the Macintosh's original 128K-byte motherboard to MicroGraphic Images.) The price for a complete 1024K-byte system including the Macintosh computer is \$3495. For further technical information, contact MicroGraphic Images Corporation, 19612 Kingsbury Street, Chatsworth, CA 91311, (818) 368-3482.

Inquiry **620**.

**IBM PC UNIX Coprocessor**

**T**he Opus516 Personal Mainframe is a UNIX coprocessor subsystem that converts an IBM PC or plug-compatible to a 32-bit UNIX workstation. Opus516 consists of a complete port of AT&T UNIX System V (release 2.0) and a 32-bit coprocessor.

The UNIX coprocessor is based on National Semiconductor's 32016 processor and includes the 32082 memory-management unit and 32081 floating-point unit. On-board memory is

expandable to 2 megabytes. Included with UNIX System V and its utilities are C and FORTRAN-77 compilers, an assembler, and a debugger. Opus516 supports UNIX and PC-DOS.

In OEM quantities, a 1-megabyte configuration is \$3140 with a single-user object license. Multiuser licensing is available as an option. Contact Opus Systems, Suite 120, 960 San Antonio Rd., Los Altos, CA 94022, (415) 941-7201. Inquiry **621**.

**Multiuser Database Environment**

**S**entinel Computer's SMX for the IBM PC, XT, or AT is a combination of a four-channel serial-interface board and a multiuser executive software package. Its multiuser database-oriented operating environment accommodates up to five terminals and five printers.

The interface board for SMX uses standard RS-232C serial ports. It supports port speeds ranging from 300 to 9600 bps.

The SMX-Executive software is menu-driven and has a help facility. It includes an integrated database mana-

ger, interactive on-line operations, multitasking, virtual memory, a print spooler, and multiple language/

character capability.

SMX sells for \$1495. For further details, contact Sentinel Computer Corpora-

tion, 9902 Carver Rd., Cincinnati, OH 45242, (513) 984-6622. Inquiry **622**.

**RAM Card for the Chameleon**

**A**n expansion board for the Chameleon and Chameleon Plus portable is available from Seequa Computer. The Chameleon RAM Plus Card comes with 128K, 256K, or 384K bytes of RAM. The 384K-byte version gives you 640K bytes of total RAM, the maximum on the Chameleon or Chame-

leon Plus.

The Chameleon RAM Plus Card comes standard with a real-time clock and a print spooler. It lets you create a RAM disk as a third disk drive. The card requires DOS 2.0 and 256K bytes of RAM resident on the main logic board.

Prices for the Chameleon

RAM Plus Card are \$395 for the 128K-byte version, \$595 for 256K bytes, and \$795 for 384K bytes. For complete product specifications, contact Seequa Computer Corp., 8305 Telegraph Rd., Odenton, MD 21113, (301) 672-3600. Inquiry **623**.

(continued)



## NEW SYSTEMS

**Sprite, a Multiuser System, Features the 80286**

Jarogate Limited's Sprite is a multiuser microcomputer designed with Intel's 6-MHz 80286 microprocessor and featuring Digital Research's Concurrent CP/M 3.1 on its main processor and CP/M Plus on a slave. Ethernet capabilities are built in. Standard system hardware is made up of a 5¼-inch 790K-byte floppy-disk drive, a 21-megabyte hard disk, and a five-slot S-100 bus.

Sprite, which comes with a keyboard and a high-resolution green or amber monitor mounted on a tilt-and-swivel base, has its central processor, an interrupt controller, two serial and three parallel I/O bidirectional ports, and a socket for an optional 80287 mathematics coprocessor on its main printed-circuit board. Its serial ports have full handshaking and can operate at speeds of up to 38,400 bps. S-100 support logic and connectors for memory boards also reside on the main PCB.



Jarogate's Sprite has built-in Ethernet capabilities.

Sixty-four dynamic RAM chips of either 64,000 or 256,000 bits can be installed on the Sprite's memory boards, thereby offering RAM capacities ranging from 512K bytes to 2 megabytes. An 8027 memory-management unit polices operations while providing automatic refresh and full-

speed memory access without wait states. The standard Sprite chassis can accommodate 6 megabytes of RAM.

The OWI, or outside world interface, board carries out high-speed disk I/O for the Sprite. The OWI board has a 6-MHz Z80B, 256K bytes of RAM, a hard- and floppy-

disk controller, DMA, and the Ethernet controller with support logic and battery-backed real-time clock. The disk controller gives you a SASI (Shugart Associates Standard Interface) connection for your drives, and the RAM serves as an I/O buffer and cache memory.

The basic Sprite has two RS-232C serial ports for a pair of workers, and additional ports will expand Sprite for as many as 18 employees. Such options as IBM PC-compatible color graphics and an 8-port I/O board can be purchased. Many specialized S-100 boards from third-party vendors reportedly work with Sprite. UNIX System V and Concurrent DOS IV are planned.

Pricing for the Sprite was unavailable at press time. For further information, contact Jarogate Ltd., 197-213 Lyham Rd., Brixton, London, SW2 5PY, England; tel: 01-671 6321; Telex: 8950094 JARO G. Inquiry **624**.

**68000 Micros from England**

U-Microcomputers, Warrington, England, has launched a line of microcomputers built on the 32-/16-bit 68000 microprocessor. The U-Man Series 1000 is centered around a basic 128K-byte microcomputer that features on-board RAM expansion to 1 megabyte, dual 800K-byte floppy-disk drives, monochrome and RGB outputs, and a 97-key keyboard.

Graphics resolution is said to be 270 and 680 pixels, depending upon operating mode and configuration. External connections comprise a pair of serial ports, a Cen-

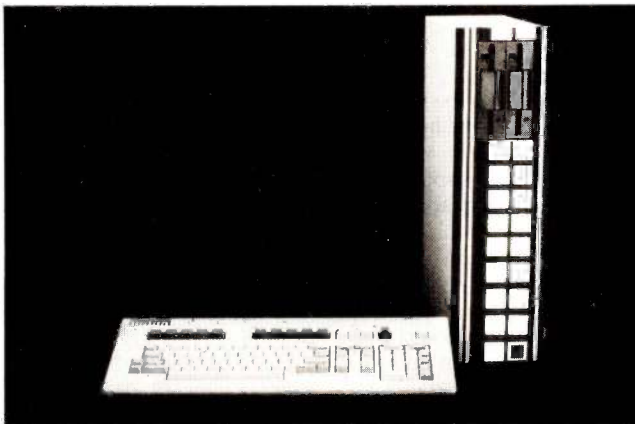

The Series 1000 can handle up to 1 megabyte of RAM.

tronics parallel port, a general-purpose 16-bit outlet, and a 10-bit A/D jack for joysticks. The U-Man

Series 1000 also has a speech synthesizer, sound generator, and a 6809 chip to supervise I/O operation.

Two operating systems, CP/M-68K and UCSD p-System, are offered. With CP/M-86K, the U-Man Series 1000 will support Digital Research's CBASIC, Pascal MT+, C, and 68000 assembler packages as well as SVC FORTRAN and Cambridge LISP. Pascal, BASIC, FORTRAN, and 68000 assembler work with the p-System.

A hard-disk option will be available. Pricing for the U-Man Series 1000 begins at £2499. Contact U-Microcomputers Ltd., Winstanley Industrial Estate, Long Lane, Warrington, Cheshire WA2 8PR, England; tel: (0925) 54117; Telex: 629279 UMICRO G. Inquiry **625**.

NEW SYSTEMS

**HP 260: Line of Small Business Computers**

**H**ewlett-Packard's HP 260 family of multiuser, small-business computers is presently made up of three models, the 15, 24, and 55. The Model 260 family, whose introduction represents the next step in the evolution of HP's Model 250 microcomputer, is fully compatible with hardware and software created for its primogenitor. It can handle

HP plotters and the ThinkJet and LaserJet printers. The manufacturer says that the HP 260 is its first computer, other than its personal computers, to support these printers.

All units measure 29 inches tall, 15 inches wide, and 28½ inches deep. A 14-inch monitor and a keyboard are supported as a workstation alternative.

The entry-level HP 260 Model 15 has 256K bytes of RAM, a 15-megabyte hard-disk drive, and a 3½-inch microfloppy-disk drive. It lists for \$10,500.

With 512K bytes of RAM, a 24-megabyte hard disk, and streaming-tape backup, the Model 24 can be expanded to provide 190 megabytes of disk storage. Pricing begins at \$16,300.

The top-of-the-line Model 55 can be enhanced to support as many as 18 users. It comes with the same amount of RAM as the Model 24, a streaming-tape backup, and 55 megabytes of hard-disk storage. The Model 55 begins at \$20,500.

For more information, contact your local Hewlett-Packard sales office. **Inquiry 626.**

SOFTWARE • APPLE

**Mix Arabic, English, and Graphics on IIc**

**A** multilingual word-processing system for the Apple IIc has been created through the joint efforts of DIWAN Science and Information Technology and Attar Computers Limited. The system uses the IIc's bit-mapped display to print Arabic and English text in either high resolution (40 columns) or double high resolution (80 columns).

Supplied utility programs let you mix high-resolution graphics with text. Graphics can also be manipulated and enhanced with Apple's Mousepaint program. Arabic and English texts can have

independent windows, each of which supports independent scrolling.

This word processor supports two Arabic fonts as well as English, French, and

German fonts. It's supplied with both Arabic fonts and the English font, a bilingual notepad program, an address program, and Image-writer bilingual driver routines. The Arabic text supports full vowel points and fully conforms with the ASMO 449 standard.

The word processor is £295. Contact DIWAN Science and Information Technology, London House, 271 King St., London W6 9LZ, England; tel: (01) 741 8011; Telex: 261507 MONREF G (quote reference number 2785). **Inquiry 627.**



*Windows, English, and Arabic displayed on the IIc.*

**Personal Income Planning Set**

**A** set of programs for the Apple IIc and IIe, Plan Ahead comprises applications that help you plan your retirement income, life-insurance coverage, and college-fund savings. Published by Advanced Financial Planning, Plan Ahead modules are designed to work alone or in conjunction with one another.

Each module lets you account for inflation and print out its various components, such as budget statements

and year-by-year itemizations. Financial data can be swapped between modules, all of which are menu-driven and fully documented.

The Retirement Planning module helps you create a total retirement plan in light of your particular circumstances. It details the inflation rate applicable to your budget, the funds that will be required at retirement, the amount of your retirement fund covered by your current assets, and other

data. This program can analyze your plan, determine if changes are necessary, and suggest where changes might be made.

Life Insurance Planning aids in the determination of the amount of insurance needed to provide for your family in the event of your sudden death. It considers such expenses as daily living, college fees, and funeral charges and ciphers them with hoped-for income from Social Security, current

assets, and the projected income of your spouse.

College Funding calculates savings in two ways: lump-sum investment in the first year or yearly amounts to accumulate the necessary funds.

Single modules are \$29.95. Two together are \$49.95, and the entire set is \$59.95. Contact Advanced Financial Planning, 20922 Paseo Olma, El Toro, CA 92630. **Inquiry 628.**

*(continued)*



## SOFTWARE • APPLE

**Compiled Logo Runs on Mac**

**A** compiled version of the Logo language, ExperTelligence's ExperLogo is available for Apple's Macintosh microcomputer. ExperLogo uses the Mac's user-interface conventions and has been enhanced with such features as array processing and data-file handling. The publisher says that it is the only compiled version of Logo available and that it is the first Logo

to process items and lists using arrays.

ExperLogo's turtle graphics reportedly operate at speeds up to 100 times faster than that of other Logos. Its Bunny Graphics feature gives you bunnies that move about the screen in three-dimensional space. The bunnies respond to such navigation commands as yaw, roll, and pitch, and they can reside in cubes

and spheres.

Its data-file handling abilities lets ExperLogo programs create and read their own files. Programs can be accessed from other applications through the Mac's standard text and graphic interfaces. A few of the list-processing features are said to be adapted from LISP.

ExperLogo programs are not limited to 128K bytes of RAM because of a feature

known as load-on-call. This means that procedures are stored on disk and automatically loaded when called if they are not already present in memory.

The suggested retail price is \$149.95. A French version of ExperLogo is available. Contact ExperTelligence Inc., 559 San Ysidro Rd., Santa Barbara, CA 93108, (805) 969-7874. **Inquiry 629.**

**Full Database Lets You Customize Applications**

**H**elix, a data-based information-management and decision-support system, gives your Apple Macintosh full database capabilities and allows you to customize applications development. This program performs traditional database-management tasks, such as filing, sorting, and data retrieval, yet it can be used for complex data analyses and task modeling.

Helix lets you devise your own task-specific applications. Data needs only to be entered once for use with a variety of jobs, and database structures are easily modifiable. Helix works with both text and numbers.

The Helix user interface employs icons for each of its functional operations. You can link the icons together in a flowchart with data from any related file. This gives you a quick way of setting up relationships and calculations that you can

tailor to specific applications. All the Mac's user-interface conventions, including the mouse, windows, and pull-down menus, are used by Helix.

Helix runs on 512K-byte Macintoshes and Lisas equipped with an external

disk drive or a hard disk.

With a demonstration disk and tape, sample applications, and manual, Helix is \$395. Contact Odesta Corp., 3186 Doolittle Dr., Northbrook, IL 60062, (312) 498-5615.

**Inquiry 630.**

**MacChoice Helps Make Decisions**

**M**acChoice from Superex Business Software lets you use the Macintosh for making comparisons. MacChoice lets you compare and rate two, three, or four items simultaneously using as many as 20 categories. Categories are listed

in order of importance, and each item is rated by its categories. This program tabulates each individual item's ratings and displays the results in a bar graph. The chart provides a visual representation of each item's ratings, which simplifies your

decision-making process.

MacChoice costs \$49.95. For more information, contact Superex Business Software, 151 Ludlow St., Yonkers, NY 10705, (800) 862-8800; in New York, (914) 964-5200.

**Inquiry 631.**

## SOFTWARE • IBM PC

**Database Manager for Applications Development**

**A** database-management system designed for applications development. Progress is intended to replace traditional languages and the development methods built around them. The system consists of five key components: a data dictionary, an application language, a screen and report formatter, a procedure editor, and a relational

database manager.

The Progress language has a library of operators and functions, including square root, logarithm, concatenation, and string-matching operations. The syntax-checking editor positions the cursor on the incorrect word or phrase, and a help facility provides error explanations and access to definitions in the data

dictionary.

The relational database manager supports databases of more than 5 billion bytes, and up to 1000 files and indexes can exist in each database. Each record can contain an unlimited number of fields within a maximum record size of 2000 bytes. Because all fields occupy only the number of bytes needed to hold the data,

the vendor said, storage requirements on disk are generally reduced 30 to 60 percent.

Progress for the IBM PC costs \$695; versions for UNIX machines range from \$2450 to \$4450. For more information, contact Data Language Corp., 5 Andover Rd., Billerica, MA 01821, (617) 663-5000. **Inquiry 632.**

SOFTWARE • IBM PC

**Have a Talk with Your Computer**

**R**acter is a program that engages in conversation ranging from serious discussion to small talk. The program also tells jokes and stories and can recall and refer to conversations it has had. (Racter is reportedly the first program to author a book. *The Policeman's Beard Is Half Constructed*, published by Warner Books last year, is a collection of stories, poems, essays, and limericks created by Racter.)

According to the developers, Racter never repeats itself because, unlike programs like Eliza, it contains no stock responses and has

its own "eccentric personality." The vendor touts the program as a mix of educational and entertainment software and notes that Racter is being used as a tool to sharpen the interviewing skills of psychiatric interns. No technical knowledge is needed to use the program.

For the IBM PC and compatibles, Racter is \$69.95. Apple and Commodore versions are in the works. Contact John D. Owens Associates Inc., 12 Schubert St., Staten Island, NY 10305-2999, (718) 448-6283. Inquiry **633**.

**Large Print for the Visually Impaired**

**C**omputer DiskCourse has developed several programs for people with poor vision. Lyon Large Print is a screen-review package that provides nine print sizes, three space settings, and, on color machines, 16 foreground and background colors for applications software running on the IBM PC and compatibles. You can generate large-print hard copy with an IBM dot-matrix printer. Lyon Large Print is designed to work with other packages for the visually impaired, including the PC Talking Program. The software costs \$490 and in-

cludes a text editor; a demo disk costs \$20.

WordLyon is a specially configured large-print version of WordStar. Letters range in height from 2 to 4½ inches. The program costs \$150.

LargeLotus, an interactive large-print driver for Lotus 1-2-3, costs \$200.

The company will customize other software to work in large-print format. Contact Computer DiskCourse, 4546 John St., Vancouver, British Columbia V5V 3X2, Canada, (604) 876-1287. Inquiry **634**.

SOFTWARE • CP/M / MS-DOS

**Three for Digital Research Products**

**C**BC Tools is a function library for use with Digital Research's CBASIC compiler. It has more than 100 functions to perform string manipulation, sorting, radix conversion, bit and byte manipulation, and interfacing with the operating system. Most of the program was written in assembly language; you can develop libraries of your own in compiled CBASIC. CBC Tools is available for CP/M-80 and CP/M-86 at a price of \$100 (plus \$5 for shipping).

CBCXREF is a cross-reference utility for the CBASIC compiler. Its user options let you set page length and width and sort output. The utility can find unreferenced variables and labels and identify unused variables and labels. CBCXREF is available for CP/M-80 and CP/M-86 at a price of \$80 (plus \$3 shipping).

MBPASLIB is a replacement library for PASLIB (used with Pascal MT+). According to the vendor, pro-

grams using MBPASLIB are typically 4K to 5K bytes smaller and up to 100 percent faster than those using

PASLIB. The library is available for CP/M-80 and costs \$75 (plus \$3 shipping). Contact Minnow Bear Com-

puters, POB 2233, Station A, Champaign, IL 61820-8233, (217) 398-6883. Inquiry **635**.

**Artificial Intelligence at Home**

**D**ynamic Master Systems has developed an AI programming system for CP/M and MS-DOS environments that gives home computer users the tools to create their own expert systems. TOPSI is a native-code version of OPS-5, a high-order language for

development of expert programs. To make TOPSI efficient on its microprocessor hosts, DMS has added several enhancements to the OPS-5 language definition and placed a few restrictions on the sizes of data structures.

TOPSI, which costs \$75

(plus \$5 shipping), is available for most Z80 CP/M systems with 65K-byte memory and most IBM PC-compatibles with at least 128K bytes. Contact Dynamic Master Systems Inc., POB 566456, Atlanta, GA 30356, (404) 565-0771. Inquiry **636**.

**Business-Applications Language**

**A** high-level language for business applications, Lucid is reportedly easier to learn and use than conventional programming languages because it has special business features and a database system built in. Functions include data conversion, string manipulation, form input, screen

handling, report generation, and math operations. Programmers can define their own functions, and the language supports all C statements except GOTO.

Lucid can read dBASE files directly. It can access data from Framework, Symphony, Lotus 1-2-3, and all spreadsheets.

A version for the IBM PC and compatibles sells for \$295. UNIX and XENIX versions are available under OEM and licensing agreements. Contact Lucid Software Corp., 3080 Valmont Rd., Boulder, CO 80301, (303) 442-4981. Inquiry **637**.

(continued)



SOFTWARE • CP/M / MS-DOS

**Database Management System**

**D**atamaster is an information system designed to provide on-line information retrieval and update of single or multiple database sources. Through its modules and sub-modules, you can make or modify a record structure or a data-screen entry and generate reports to your specifications.

The program allows mixed fields on the same screen from a single or multiple database. You can retrieve relative information from one or several databases

and update one or more databases from the same screen. You can also link screens from one to another; the vendor claims there is no limit to the number of screens you can link.

Datamaster operates on most computers running under CP/M, MP/M, MS-DOS, TurboDOS, ITT-DOS, and Oasis. Suggested retail price is \$495. Contact C.D.A. International Software Corp., Suite 330, 14900 Ventura Blvd., Sherman Oaks, CA 91403, (818) 986-3233. Inquiry **638**.

**Half-Duplex Communications**

**I**ntended primarily for use with the existing radio telephone network, HCOM is a half-duplex communications package for PC-DOS, MS-DOS, and CP/M-80 systems. The program provides all the logic necessary to support CRC 16 error checking, half-duplex link control, and user-configurable help screens and menus. Remote-site or mobile users can log on to any HCOM system and send or receive files.

HCOM can also be used in full-duplex mode and still support all the services pro-

vided in half-duplex mode. Additionally, it can be used as a terminal emulator to access bulletin-board systems or other non-HCOM systems. XON/XOFF protocol is supported. On dedicated links, HCOM operates at up to 9600 bps.

The software costs \$425 (Canadian). The AT&T 202-compatible modem, the CD-2, sells for \$625. Contact Crafield Digital, 107 Abadan Crescent NE, Calgary, Alberta T2A 6P1, Canada, (403) 273-9738. Inquiry **639**.

SOFTWARE • OTHER COMPUTERS

**Screen Dump from MBC 550**

**S**napshot allows Sanyo MBC 550 screen dumps at any time. It also lets you zoom in on smaller areas of the screen. It has three operating modes: character, color graphics, and high-resolution black-and-white graphics. The character mode can be used for fast printing of screen data; the color-graphics mode prints a side view of the screen with colors shown as distinguishable dot patterns.

Snapshot works with any dot-matrix printer with graphic capabilities and a parallel port. Horizontal and vertical scaling, color-to-dot pattern representation, and the keystrokes used to invoke its operations can be modified. Snapshot is pre-configured for various printers. It runs on versions of MS-DOS that occupy under 2.5K bytes of main memory. It costs \$34.95, plus \$1 shipping. Contact Key Software Products, 440 Ninth Ave., Menlo Park, CA 94025, (415) 364-9847. Inquiry **640**.

**Structured Programming Language Released for Commodore**

**A** high-level, structured programming language similar to C and Pascal, PROMAL runs on the Commodore 64. Systems Management Associates says that PROMAL's fast compiler and a highly efficient run-time en-

vironment let you write applications for the Commodore 64 in a high-level language, where once such programs had to be written in assembly language.

PROMAL (Programmer's Micro Applications Lan-

guage) comes with a one-pass compiler, a full-screen editor, a command executive, and a library of predefined utilities. The PROMAL executive provides file, memory, and program management as well as I/O redirection. A full-screen, cursor-driven editor helps you enter and edit your source program rapidly.

The library of machine-language subroutines supports the PROMAL run-time environment with optimized routines for file I/O, string handling, formatted output, and data conversion. Benchmarks that reportedly show PROMAL to be from 70 to 200 percent faster than BASIC, COMAL, FORTH, and Pascal are available from the manufacturer.

PROMAL is \$49.95 factory-direct. A developer's version with an unlimited run-time distribution license is \$99.95. Contact Systems Management Associates, 3700 Computer Dr., POB 20025, Raleigh, NC 27619, (919) 787-7703. Inquiry **641**.

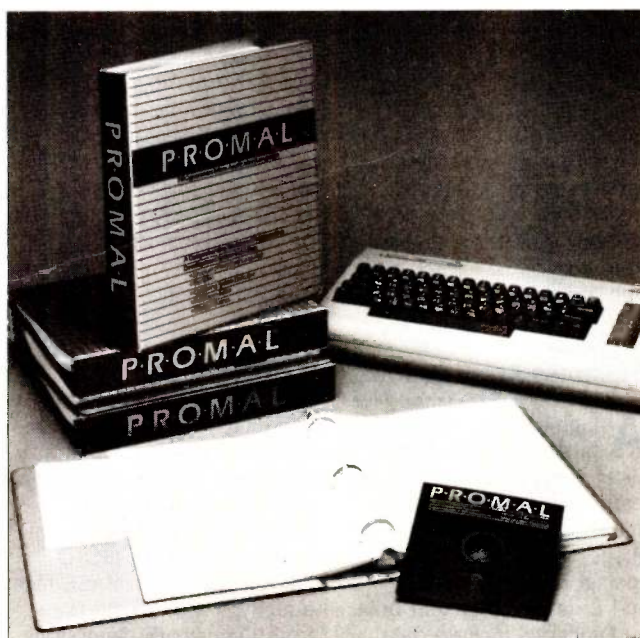

PROMAL for the C-64 is similar to C and Pascal.



**Communications Software for Portable**

**G**eneva Connection is a ROM-cartridge telecommunication program that lets users of Epson's Geneva portable computer communicate directly with external storage units or by modem with other computers. It can handle communications with remote computers by means of add-on or external modems and through acoustic couplers. Data can also be sent or retrieved from a floppy disk, RAM disk, or microcassette.

Geneva Connection offers two means of transferring files: XON/XOFF flow control and a block protocol with error detection and correction. It works with either pulse or tone dialing and is capable of automatic dialing.

Other features are English-language command structures, automatic-answer



*Geneva Connection is a communications package for the Epson portable.*

capability for preset time periods, full range of communication speeds, and selective filtering and replacement of characters for such applications as file transfers between word

processors.

The retail price for the Geneva Connection is \$79. Contact Epson America, 2780 Lomita Blvd., Torrance, CA 90505, (213) 539-9140. **Inquiry 642.**

**CP/M Plus for Cromemcos**

**S**uper Bios Plus is a revised version of CP/M Plus for Cromemco computers said to incorporate a memory-management method that uses interbank memory moves and banking of disk drivers to achieve a 60K-byte program area. Its file system features hashed directory access, record buffering, and multisectored disk I/O.

Super Bios Plus is upward-compatible with CP/M 2.2 for applications programming, and it supports up to 16 hard disks.

Console I/O redirection utilities are available for applications programming transparency. Extended system utilities include programs that list file directories and transfer files. A batch facility is provided.

A CDOS emulator for run-

ning Cromemco software under CP/M and MP/M. Expand is a supplied system extension. Super BIOS Plus also incorporates a component that allows Cromemcos to read data disks created on the IBM PC.

Super BIOS Plus with Expand costs \$375. It supports single- or double-sided,

single- or double-density 5¼- and 8-inch disks. Source code and copy and disk-formatting programs are supplied. Contact Micro Applications & Hardware, 15 Princess St., Sausalito, CA 94965, (415) 331-6422; east of the Rockies, (314) 434-1896. **Inquiry 643.**

**WHERE DO NEW PRODUCT ITEMS COME FROM?**

*The new products listed in this section of BYTE are chosen from the thousands of press releases, letters, and telephone calls we receive each month from manufacturers, distributors, designers, and readers. The basic criteria for selection for publication are: (a) does a product match our readers' interests? and (b) is it new or is it simply a reintroduction of an old item? Because of the volume of submissions we must sort through every month, the items we publish are based on vendors' statements and are not individually verified. If you want your product to be considered for publication (at no charge), send full information about it, including its price and an address and telephone number where a reader can get further information, to New Products Editor, BYTE, POB 372, Hancock, NH 03449.*

**Utilities for LaserJet**

**J**etSet, a pair of utilities for Hewlett-Packard's LaserJet printer, runs on the HP 150 touch-screen computer, the IBM PC, and PC-compatibles. Both utilities interface transparently with each other and can be used with any text editor or word processor.

SetLaser, the first utility, executes a string of commands that initialize the LaserJet and direct its output to the communications port. It provides access to the LaserJet's formatting capabilities, including typefaces, lines per inch, number of copies, and page length. Multiple formats can be saved for use with different documents.

The second utility is Runoff. It lets you set tab stops, margins, and page feeds from within the document being printed. It can be used for generating headers, footers, and page numbers and underlining portions of text.

JetSet is \$79. Contact Datamate Co., Suite 128, 4135 South 100 East Ave., Tulsa, OK 74146, (800) 262-7276; in Oklahoma, (918) 664-7276. **Inquiry 644.**

**MSX Source Code Manual**

**Q**est Publishing has released a complete BIOS manual for the MSX standard.

*MSX BIOS: The Complete MSX BASIC I/O Listing* contains the full source code for MSX BASIC. This soft-cover book retails for \$69.95. Contact Qest Publishing Inc., Suite 800, 39 West 32nd St., New York, NY 10001, (212) 564-0749. **Inquiry 645.**



# CCT-4 SYSTEM SERIES

The latest CCT implementation of the new generation Intel 16-Bit Processor technology. This means extreme speed, unequalled power, and the ultimate in reliability, and of course, the innovators at CCT behind it.

This series in the CCT line exploits the speed and power of the Intel 80286 and Zilog Z-80H (8MHz), on the 286Z CPU board. This combination, along with CompuPro DMA controllers and I/O boards, yields a dramatic improvement in system throughput speeds, from basic CP/M operation, up to large powerful multi-user/multi-tasking machines. The CCT-4 represents the most advanced hardware presently available in a microcomputer to run the thousands of CP/M type software programs on the market, and with CONCURRENT DOS 8-16 and the CompuPro PC Graphics board (when available), all software written for the IBM PC machines. This series is for the serious business/scientific user.

**CCT-4A** State-of-the-art power in it's basic form. Consists of CCT-286Z CPU board and CCT-M256 (256K), along with CompuPro: Enclosure 2 Desk (21 slot MF), Disk 1A, System Support 1, Interfacer 4, the CCT-2.4 floppy drive system, and CP/M 80 and CP/M 86, and with SF-200 surge suppressor system. . . . . **\$5,995.00**

**CCT-4B** Single-user/hard disk power. As the 4A, except priced without the CCT-2.4, to add in your choice of CCT hard/floppy combination drive subsystem, at the published pricing. . . . . **\$4,895.00**  
 (Example: CCT-4B Mainframe with CCT-10/1 = \$7,244.00) Plus cost of selected drive subsystem

**CCT-4C** Multi-user/hard disk power. As the 4B, with the CCT-M512 (512K static RAM board) instead of M256; Interfacer 3 instead of Interfacer 4; SF-400 instead of SF-200, plus Concur. DOS 8-16 O.S. (6 user system) . . . . . **\$6,695.00**  
 (Example: CCT-4C Mainframe with CCT-40/1 = \$10,044.00) Plus cost of selected drive subsystem

**NEW RAM BOARD**

**Limited Time Offer - FREE Supercalc 86 with any CCT-4**

The above systems include all necessary cabling, assembly, testing, minimum 20 hour burn-in, and the CCT unconditional 12 month direct warranty.

**CCT-M512** CCT introduces it's 512K static RAM board. IEEE Standard 12MHz. 512K in one slot! **Introductory Price: \$1,995**  
**CCT-M256** 256K version of M512 upgradeable to full 512K. Perfect 256K RAM board for any CompuPro system . . . . **\$1,029**

**CUSTOM COMPUTER TECHNOLOGY / BOX 4160 / SEDONA, ARIZONA 86340**  
**TOLL FREE ORDERING: 800-222-8686 / For technical support / service: 602-282-6299**

## HIGH REL ★ SWITCHING POWER SUPPLIES ★ LOW COST

**SW40W**



**SW70W**



**SW80W**



**SW138**



**SW150**



**S3 & S4**



**R1 & R1A**



ITEM	FOR	+5V	-5V	+12V	+12V	-12V	+24V	+8V	±16V	W x D x H in.	TERMINALS	PRICE
SW40W	TERM. & 2 ALPS DRIVES	2.5A	-	2/2.5A pk.	-	.3A	-	-	-	6.3 x 3.9 x 1.9	MOLEX 5051	\$ 54.95
SW70W	APPLE III®, IBM PC-I, II®	7A	.3A	2.5/3.5A pk.	-	.3A	-	-	-	9.6 x 4 x 2.4	MOLEX 126-P1	64.95
SW80W	PC WITH SOFT DRIVES	8A	.3A	3/4A pk.	-	.3A	-	-	-	7.4 x 4.5 x 2.3	MOLEX 2139	74.95
SW138	IBM PC-XT® P/S RPLCMNT.	15A	1.0A	4/5A pk.	-	1.0A	-	-	-	9.5 x 5.6 x 4.6	MOLEX, AMP.	129.95
SW150	PC WITH HARD DRIVES	12A	.3A	4/5A pk.	2.5A	.5A	-	-	-	10.4 x 5 x 2.5	TERM. BLOCK	139.95

SPECS. OF ABOVE SWITCHERS: 117/220 VAC SELECTABLE, INPUT 90-132 VAC/180-275 VAC, EFFIC. 75% TYPICAL, LINE REGUL. 0.3%, LOAD REGUL. 1% ON +5V, 5% ON OTHER VOLTAGES, 6.2 OVP SETTING ON +5V, OVERLOAD & SHORT CIRCUIT PROTECT, LOW OUTPUT RIPPLE & NOISE, 1% MAX, 50,000 HRS. MTBF RELIABILITY, UL, FCC & VDE SAFETY & NOISE STANDARDS.

S3	FOR S-100, 10 SLOTS	5A	1A	*	-	-	5/7A pk.	12A	3A	10 x 6 x 5	SOLDER POST	\$105.95
S4	FOR S-100, 6 SLOTS	4A	1A	*	-	-	4/5A pk.	8A	2.5A	8.4 x 5 x 4.8	SOLDER POST	89.95
R1	2 FLOPPY DRIVES	3A	.5A	*	-	-	3/4A pk.	-	-	8 x 4 x 3.4	SOLDER POST	44.95
R1A	APPLE II PC®	3A	.5A	3/4A pk.	-	.5A	-	-	-	8 x 4 x 3.4	SOLDER POST	46.95
C64	COMPATIBLE TO COMMODORE C64 (OR C+4)* POWER SUPPLY: +5V/1.7A, 9 VAC/1A & 117 VAC IN, POTTED & U/L.	-	-	-	-	-	-	-	-	-	-	19.95

\*: +24V CAN BE CHANGED TO +12V BY FACTORY, PLEASE SPECIFY WHEN YOU ORDER.  
 THE ABOVE 5 LINEAR P/S ARE WITH 3% LOAD REGUL., OVP ON +5V, FUSED: INPUT & OUTPUTS.

**POWER TRANSFORMERS: (WITH MOUNTING BRACKET) ON SALE**

ITEM	PRIMARY	SECOND. #1	SECOND. #2	SECOND. #3	W x D x H in.	PRICE
T1	110/120 VAC	2 x 8 VAC/7A	28 VAC, CT, 2-5A	-	3 3/4 x 3 3/8 x 3 1/8	\$15.95
T2	110/120 VAC	2 x 8 VAC/12A	28 VAC, CT, 3A	-	3 3/4 x 4 3/8 x 3 1/8	21.95
T3	110/120 VAC	2 x 8 VAC/6A	28 VAC, CT, 2A	28 VAC, CT, 3A	3 3/4 x 4 3/8 x 3 1/8	23.95
T4	110/120 VAC	16 VAC, CT, 4A	28 VAC, CT, 1.5A	28 VAC, CT, 3A	3 3/4 x 3 3/8 x 3 1/8	17.95
T4-1	110/120 VAC	16 VAC, CT, 4A	28 VAC, CT, 1.5A	48 VAC, CT, 2A	3 3/4 x 3 3/8 x 3 1/8	14.95
T5	110/120 VAC	16 VAC, CT, 3A	28 VAC, CT, 2A	-	3 x 3 x 2 1/2	11.95



**SHIPPING:**  
 FOR EA. POWER SUPPLY: \$6.00 IN CALIF.; \$8.00 IN OTHER STATES; \$18.00 IN CANADA.  
 FOR EA. TRANSFORMER: \$6.00 IN ALL STATES; \$12.00 IN CANADA, CALIF. RESIDENTS ADD 6.5% SALES TAX.

IBM PC/PC-XT®, APPLE II/III® & COMMODORE C64/C+4\* ARE TRADEMARKS OF IBM CORP., APPLE COMPUTER INC. & COMMODORE BUSINESS MACHINES, RESPECTIVELY.

MAILING ADDRESS:  
 P.O. BOX 4296  
 TORRANCE, CA 90510  
 TELEX: 182558



**SUNNY INTERNATIONAL**  
 IN BUSINESS SINCE 1975  
**(213) 328-2425 MON-FRI 8:30-5:30**



SHIPPING ADDRESS:  
 22129 1/2 S. VERMONT AVE  
 TORRANCE, CA 90502



**TOLL-FREE  
ORDERING:  
800-222-8686**

**FOR TECHNICAL SUPPORT/  
SERVICE / IN ARIZONA:  
602-282-6299**

# CCT<sup>®</sup> CUSTOM COMPUTER TECHNOLOGY

**1 CCT PLAZA — P.O. BOX 4160 — SEDONA, ARIZONA 86340**

Purchase your Hardware and Software directly from an OEM / Systems Integrator. Take advantage of our buying power! We stock a full line of Board Level Components, Software and Peripherals. Call for your needs. We'll give you the Lowest Prices, and the Technical Support and Know-How we are quickly becoming well-known for. Satisfied Customers Nationwide. The Nation's Custom Systems House for Business, Education and Science. Call for a system quote. CCT implements tomorrow's technology today!

**• FOREMOST QUALITY • ADVANCED SUPPORT • REASONABLE COST •**



### 80286 NOW!

☐ **CCT-286Z** is our model designation for the **MI-286** dual processor board from **Macrotech**. It features the super high speed combination of Z-80H and 80286, with provision for the 80287 math chip. Directly replaces 8085/88 and 8086 CPUs running CP/M, MP/M Concurrent DOS, and MS-DOS, at throughput increases of 3X to 5X!

**SPECIAL PRICE - \$1099**  
**80287 Option - Installed - \$395**

**SEE THE CCT-4 SERIES  
USING THIS BOARD  
DETAILED ON THE FACING PAGE**

### NEW—TRUE IBM PC INTERFACE ULTRA HI-RES GRAPHICS!

CCT S-100/PC is a break-through for the Science/Business user. Mini-enclosure accepts PC & compatible boards and directly connects to your S-100 system, running PC-DOS or Concurrent DOS. Hercules™ Graphics System—Coming this May!  
**!! THE BEST OF BOTH WORLDS !!**

#### LIBERTY TERMINALS

• Superior Reliability •

100-12" GREEN-25 X 80 ..... \$399  
110-14" GREEN-80/132 Column ..... \$499  
200-14" GREEN-80/132 Super Deluxe ..... \$569  
220-14" GREEN-DEC Compatible ..... \$699

#### CCT RECOMMENDS—

AMBER Screen Options ..... \$20

#### OKIDATA PRINTERS - Top Quality

82 - 80 Col. ... \$329 83 - 132 Col. ... \$619  
92 - 80 Col. ... \$429 93 - 132 Col. ... \$659  
84 - 132 Col./200cps—Top of the Line ..... \$799  
For Serial Interfaces — Add ..... \$100

#### DIABLO — Letter Quality Series

Model 620 ..... \$969 Model 630 ..... \$1799

**WE HAVE ALL SOFTWARE—CALL**

## INDUSTRIAL GRADE **CCT DISK DRIVE SYSTEMS** ROLLS ROYCES OF THE INDUSTRY SUPERIOR QUALITY **S-100 HARD DISK SUBSYSTEMS**

Professionally engineered ST-506 type systems for the business market S-100 Computer user. Includes industry top quality drives, CompuPro Disk 3 DMA controller, all cabling, A&T, formatted, burned-in. Provisions for up to two hard disks in each system. We include operating system update. CP/M 80, CP/M 86, CP/M 8-16, MP/M 8-16, CP/M 68K. (/1 Systems are CCT innovated hard/floppy combinations, with Mitsubishi DSDD 8" drive.) 12 month warranty.

CCT-10 (11 + MEG) .....	\$1799	CCT-10/1 .....	\$2349
CCT-20 (22 + MEG) .....	\$2319	CCT-20/1 .....	\$2869
CCT-40 (36 + MEG) .....	\$2799	CCT-40/1 .....	\$3349
CCT-60 (58 + MEG) (New) .....	\$3999	CCT-60/1 .....	\$4549
CCT-90 (87 + MEG) (New) .....	\$5209	CCT-90/1 .....	\$5759
CCT-125 (123 + MEG) (New) .....	\$6399	CCT-125/1 .....	\$6949

## NEW 10 MEG REMOVABLE CARTRIDGE DRIVE SYSTEM

for hard disk back-up — DMA using Disk 3 controller.  
Super fast/Ultra reliable — Available April

### FLOPPY SYSTEMS

**CCT-2.4 • Dual 8" DSDD**  
Mitsubishi 2.4 Megabyte in Extra Heavy horizontal enclosure, removeable filter air system, all cabling, A&T, Burned in. The fastest system available: ..... \$1229

**CCT-5 • 5 1/4" DSDD**  
IBM Compatible Tandon 320K. Extra Heavy Cabinet accommodates two drives, hard or floppy. All cabling, A&T, Burned-in. Perfect for our PC-DOS Package ..... \$399

#### CCT-8/5 • FULL IBM COMPATABILITY

One Mitsubishi 8" DSDD (1.2 Meg)/One 5-1/4" DSDD (360K) IBM Drive  
Both 3ms step rate — For Concurrent DOS and PC DOS ..... \$1029

## ★ SUPER PRICES ★ COMPUPRO COMPONENTS ★ IN STOCK ★

CPU-Z - \$229 • Disk 1A - \$519 • Disk 1A w/CP/M - \$619 • CPU 8086/87 - \$819 • SPU-Z - ?  
CPU 8085/88 - \$349 • CPU 8086 - \$559/10Mhz - \$599 • CPU 68K - \$519/10Mhz - \$639  
PC Graphics - \$399 • Disk 3 - \$499 • RAM 22 (256K) - \$1179 • RAM 23/64K - \$309/128K - \$599  
**NEW** — M-Drive/H - 512K - \$599 / 1 Meg - \$1149 / 2 Meg - \$2099 / 4 Meg - \$3799  
Enclosure 2 Desk - \$649/Rack - \$699 • Interfacer 3 - \$499 • Interfacer 4 - \$349 • System Support 1 - \$329  
Concurrent DOS 8-16 (CCTCMX) - \$309 • CP/M 80 (CCTHMX) - \$125 • CP/M 86 (CCTTMX) - \$175  
CP/M 8-16 (CCTTMX) - \$199 • CP/M 68K (CCTCX) - \$279 • Operating System Updates/Remakes - \$30

**16 Bit Upgrade Kit: CP/M 86, RAM 23, System Support 1, Cable \$759 ☐ CP/M 8-16 - Kit - \$783**

### CCT-1 — ENTRY LEVEL S-100 BUSINESS SYSTEM

- Enclosure 2-Desk-21 Slot Mainframe •
- CPU 8085/88 - 6Mhz 8085/8Mhz 8088 •
- Disk 1A - DMA Floppy Disk Controller •
- RAM 23 - 64K Static RAM - 12Mhz •
- Interfacer 4 - 3 Serial/2 Parallel I/O •
- CCT-2.4-Dual 8" Mitsubishi DSDD Drive System - 2.4 Megabytes •
- CP/M 80 - 2.2 HMX - CCT Modified •
- All Cabling, Complete CCT Assembly, Testing, and Minimum 20 Hour Burn-in •

**SPECIAL PRICE  
\$3,559**

**RUNS ALL STANDARD 8" CP/M SOFTWARE - INCLUDES OUR EXCLUSIVE 12 MONTH DIRECT WARRANTY**

Prices & availability subject to change. All products new, and carry full manufacturer's warranties. Call for catalog. Free technical help to anyone. All products we sell are CCT individually tested and set up for your system - Plug-In & Go! Arizona residents add sales tax **CCT<sup>®</sup>** Trademark — Custom Computer Technology; **MS-DOS<sup>®</sup>** Trademark — Microsoft; **IBM<sup>®</sup>** Trademark — International Business Machines; **CompuPro<sup>®</sup>** Trademark — W.J. Godbout; **CP/M<sup>®</sup>** **MP/M<sup>®</sup>** Trademarks — Digital Research; **HERCULES<sup>™</sup>** Trademark — Hercules Computer Technology



Apple

# HARD\_DISK™

IBM, Zenith

## 5 and 10 megabyte Removables 10, 31, 55, 88, and 119 megabyte Fixed

Selected as the best buy for Apple and IBM PCs by Popular Computing Magazine, Digital Electronics Systems offers the most flexible HARD\_DISKs for Apple and IBM PCs. A mixture of Removable and Fixed HARD\_DISKs allows virtually unlimited storage

capacity. Backed by direct and immediate engineering support, each customer can now enjoy carefree usage of high performance mass storage devices. Software developed by DES was designed to allow easy quick installation and to work transparently without chang-

ing any existing software. Wordstar, Lotus 1-2-3, d-Base II, immediately take advantage of vast disk space without modification. Call a DES customer engineer today to discuss your HARD\_DISK needs.

**Apple**

- User-selected volume sizes as follows:  
DOS to 400K. PRODOS to 32 Mbytes.  
CPM to 150 megabytes.  
PASCAL to 16 megabytes.
- Up to 254 DOS volumes, 63 CPM volumes, 64 PASCAL volumes, and 63 PRODOS volumes per drive.
- Split/merge files between HARD\_DISK and floppies.
- Boot into any operating system and between operating systems.
- Up to 12 drives per Apple.

- User-selectable format interleave for maximizing performance.
- HARD\_DISK can be used in any slot (except 0).
- 2 drive controller handles any combination of Removable and/or Fixed Drives.
- Complete information on directly accessing the HARD\_DISK including direct access using your own drivers.
- Transparent operation using each operating system's present commands.
- Comprehensive manual

**IBM, Zenith**

- Internal 5, 10 and 30 mb half height drives
- External 5, 10, 30, 52, 82, and 112 mb drives
- 2 controllers C1 and C8
- User configurable volumes
- Completely IBM compatible
- Transparent flagging of bad tracks
- Works transparently with user software
- 11 Bit error detection and correction
- Backup with copy utilities or optional tape drive available from DES
- Full support and maintenance available from DES

	Removable				Fixed		
	5mb	10mb	10mb	30mb	52mb	82mb	112mb
Apple, external	1295	1995	795	1695	2995	3995	4995
Zenith 100 external	1450	2295	1395	1850	3250	4250	5250
2nd Drive	895	1495	495	1195	2795	3795	4795
	5mb	10mb	10mb	31mb	55mb	88mb	119mb
IBM PC, XT, AT - Internal	1095	1795	795	1495	—	—	—
IBM PC, XT, AT - External	1295	1995	895	1695	2995	3995	4995
Zenith 150	1295	1995	995	1695	2995	3995	4995
2nd Drive	895	1495	495	1195	2795	3795	4795
Annual Maintenance Contract	150	190	140	190	300	400	475

CASH PRICES. Inquire about CREDIT CARD and PURCHASE ORDER PRICES

### DIGITAL ELECTRONICS SYSTEMS

615-649-5137

302 South Main, Estill Springs, Tennessee 37330  
Serving the Electronics Industry since 1978.

WE ACCEPT:  
Mastercard, Visa,  
and American  
Express



**IBM PC, 256 K**, One Half Height 320 K Disk Drive DS/DD, Persyst Color Card, Taxan Green Monitor, DOS 2.1 PLUS a 10MB Hard Disk Sub System all for:

**\$2690.00**

**IBM PC, 256 K**, Two Half Height Drives DS/DD, Persyst Color Card, Taxan Green Monitor, DOS 2.1, 130 Watt Power Supply PLUS a 10MB Hard Disk Sub System all for:

**\$2980.00**

**IBM PC, 256 K**, Two Half Height Drives DS/DD, Persyst Color Card, Taxan Green Monitor, DOS 2.1, 130 Watt Power Supply, 10MB Hard Disk Sub System, PLUS 10MB Tape Back Up System all for:

**\$3579.00**

**IBM PC, 256 K**, Two Half Height Drives DS/DD, Persyst Color Card, Taxan Green Monitor, DOS 2.1, 130 Watt Power Supply, 20MB Hard Disk Sub System all for:

**\$3380.00**

**IBM PC, 256 K**, Two Half Height Drives DS/DD, Persyst Color Card, Taxan Green Monitor, DOS 2.1, 130 Watt Power Supply, 20MB Hard Disk Sub System PLUS 10MB Tape Back Up System all for:

**\$3979.00**

(We configure and test the system for you at no extra cost.)

## SOMEBODY Has To Have The Lowest Prices!

**MONITORS**

AMDEK 300	\$135.00
PGS HX-12	\$475.00
PGS MAX-12	\$190.00
PGS SR-12	\$625.00
TAXAN GREEN COMPOSITE	\$125.00
TAXAN AMBER COMPOSITE	\$135.00
TAXAN GREEN W/TTL PLUS	\$149.00
TAXAN AMBER W/TTL PLUS	\$159.00
IBM MONOCHROME DISPLAY	\$260.00
IBM COLOR DISPLAY	\$590.00

**PRINTERS**

EPSON FX 80	\$425.00
EPSON FX 100	\$625.00
EPSON RX 80	\$245.00
EPSON RX 80FT	\$295.00
OKIDATA 82A	\$299.00
OKIDATA 83A	\$569.00
OKIDATA 92P	\$399.00
OKIDATA 93P	\$625.00
OKIDATA 84P	\$759.00
OKIDATA 2410P	\$1959.00
TOSHIBA P1351	\$1295.00
NEC SPINWRITER 3550	\$1595.00
NEC PINWRITER 80 COL	\$699.00
NEC PINWRITER 136 COL	\$899.00
BROTHER HR-25	\$699.00
BROTHER HR-35	\$925.00

(Accessories on NEC & OKIDATA printers available)

**DRIVES**

TANDON TM-100-2	\$179.00
SLIMLINE - TOSHIBA	\$155.00
SLIMLINE - TEAC 55B	\$155.00

**MULTIFUNCTION BOARDS**

AST I/O+1 SER & 1 PAR	\$179.00
AST SIX PACK 64K, 1 SER & 1 PAR	\$269.00
QUADBOARD 64K	\$269.00
IBM COLOR GRAPHIC ADAPTER	\$225.00

IBM MONO PRINTER ADAPTER	\$230.00
PERSYST COLOR ADAPTER	\$190.00
PERSYST MONO PRINTER ADAPTER	\$210.00
HERCULES GRAPHIC ADAPTER	\$349.00
HERCULES COLOR CARD	\$210.00
STB GRAPHIX PLUS II	\$375.00

**MODEMS**

HAYES SMART MODEM 1200	\$469.00
HAYES SMART MODEM 300	\$209.00
HAYES 1200B PLUG IN CARD	\$429.00
QUBIE PC 212A/1200 INT	\$275.00
QUBIE PC 212E/1200 EXT	\$299.00

**HARD DISKS**

10MB SUB SYSTEM INT	\$850.00
10MB SUB SYSTEM EXT	\$1025.00
10MB TAPE BACK UP	\$599.00

**GENERAL**

CONTROL DATA DISKETTES	\$25.00/box
KEYTRONIC KB5151	\$189.00
PARALLEL CABLES	\$25.00
64K RAM UPGRADE KIT	\$50.00
128K RAM UPGRADE KIT (For AT)	\$199.00
IBM PC POWER SUPPLY (Original)	
63.5 Watts	\$89.00
IBM KEYBOARD FOR PC (Original)	\$109.00



**(714) 838-7530**

2640 Walnut Avenue, Unit K,  
Tustin, California 92680

(Prices & availability subject to change without notice—IBM is a registered trademark of IBM Corporation.)

# What the world really needs is a 99 cent Double Sided, Double Density Diskette with a LIFETIME WARRANTY!

## And DISK WORLD! has it.

### Introducing Super Star Diskettes: the high quality diskette with the lowest price and the best LIFETIME WARRANTY!

In the course of selling more than a million diskettes every month, we've learned something: higher prices don't necessarily mean higher quality.

In fact, we've found that a good diskette manufacturer simply manufactures a good diskette...no matter what they charge for it. (By way of example, consider that none of the brands that we carry has a return rate of greater than 1/1,000th of 1 percent!)

In other words, when people buy a more expensive diskette, they aren't necessarily buying higher quality.

The extra money might be going toward flashier advertising, snazzier packaging or simply higher profits.

But the extra money in a higher price isn't buying better quality.

All of the good manufacturers put out a good diskette. Period.

#### How to cut diskette prices ...without cutting quality.

Now this discovery posed a dilemma: how to cut the price of diskettes without lowering the quality.

There are about 85 companies claiming to be "diskette" manufacturers.

Trouble is, most of them aren't manufacturers. Rather they are fabricators or marketers, taking other company's components, possibly doing one or more steps of the processing themselves and pasting their labels on the finished product.

The new Eastman Kodak diskettes, for example, are one of these. So are IBM 5 1/4" diskettes. Same for DYSAN, Polaroid and many, many other familiar diskette brand names. Each of these diskettes is manufactured in whole or in part by another company!

So, we decided to act just like the big guys. That's how we would cut diskette prices...without lowering the quality.

We would go out and find smaller companies to manufacture a diskette to our specifications...specifications which are higher than most...and simply create our own "name brand" diskette.

Name brand diskettes that offered high quality at low prices.

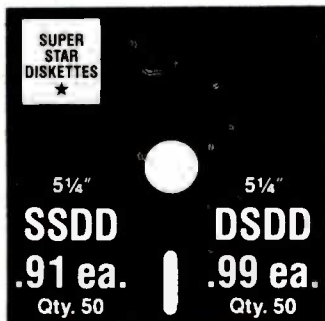

Super Star diskettes are sold in multiples of 50 only. Diskettes are shipped with white Tyvec sleeves, reinforced hubs, user ID labels and write-protect tabs.

**Boy, did we get lucky. Our Super Star Diskettes are the same ones you've been using for years...without knowing it.**

In our search for the low priced, high quality diskette of our dreams, we found something even more interesting.

We found that there are several manufacturers who don't give a hoot about the consumer market for their diskettes. They don't spend millions of dollars in advertising trying to get you, the computer user, to use their diskettes.

Instead, they concentrate their efforts on turning out the highest quality diskettes they can...because they sell them to the software publishers, computer manufacturers and other folks who (in turn) put their name on them...and sell them for much higher prices to you!

After all, when a software publisher or computer manufacturer or diskette marketer puts their name on a diskette, they want it to work time after time, everytime. (Especially software publishers who have the nasty habit of copy-protecting their originals!)

**Super Star Diskettes. You already know how good they are. Now you can buy them...cheap.**

Well, that's the story.

Super Star diskettes don't roll off the boat from Pago-Pago or emerge from a basement plant just east of Nowhere.

Super Star diskettes have been around for years...and you've used them for years as copy-protected software originals, unprotected originals. Sometimes, depending on which computer you own, the system master may have been on a Super Star diskette. And maybe more than once, you've bought a box or two or more of Super Star diskettes without knowing it. They just had some "big" company's name on them.

Super Star Diskettes are good. So good that a lot of major software publishers, computer manufacturers and other diskette marketers buy them in the tens or hundreds of thousands.

We buy them in the millions.

And then we sell them to you.

Cheap.

**When every little bit counts,  
it's Super Star Diskettes.**

You've used them a hundred times...under different names.

Now, you can buy the real McCoy, the same diskette that major software publishers, computer manufacturers and diskette marketers buy...and call their own.

We simply charge less.

#### Super Special!

Order 50 Super Star Diskettes and we'll be happy to sell you an Amaray Media-Mate 50 for only \$8.75, shipping included...a lot less than the suggested retail price of \$15.95.



Regular DISK WORLD! price: \$10.95 ea.  
+ \$2.00 Shpng.

#### DISKETTE STORAGE CASES

**PERFECTDATA DIAL 'N FILE**  
Terrific! Holds 10 5 1/4" diskettes. Just flip the lever and they all slide up for easy access and identification. Grey with smoked plastic front.

\$2.75 Ea. + .35 Shpng.

#### DISK CADDIES

The original flip-up holder for 10 5 1/4" diskettes. Beige or Grey only.

\$1.65 ea. + .20 Shpng.

#### DISKETTE 70 STORAGE

Dust-free storage for 70 5 1/4" diskettes. Six dividers included. An excellent value.

\$11.95 ea. + \$3.00 Shpng.



#### HOW TO ORDER:

**ORDERS ONLY:**  
1-800-621-6827  
(In Illinois: 1-312-944-2788)

**INQUIRIES:**  
1-312-944-2788

FOR FASTEST SERVICE, USE NO-COST MCI MAIL: Our address is DISK WORLD!. It's a FREE MCI MAIL letter. No charge to you. (Situation permitting, we'll ship these orders in 24 hours or less.)

**SHIPPING:** 5 1/4" & 3 1/2" DISKETTES—Add \$3.00 per each 100 or fewer diskettes. **OTHER ITEMS:** Add shipping charges as shown in addition to other shipping charges. **PAYMENT:** VISA, MASTERCARD and Prepaid orders accepted. **COD ORDERS:** Add additional \$3.00 special handling charge. **APO, FPO, AK, HI & PR ORDERS:** include shipping charges as shown and additional 5% of total order amount to cover PAL and insurance. We ship only to United States addresses, except for those listed above. **TAXES:** Illinois residents, add 8% sales tax.

**MINIMUM ORDER:** \$35.00 or 20 diskettes.

#### The Super Star LIFETIME WARRANTY!

Super Star Diskettes are unconditionally warranted against defects in original material and workmanship so long as owned by the original purchaser. Returns are simple: just send the defective diskettes with proof of purchase, postage-paid by you with a short explanation of the problem, and we'll send you the replacements. (Incidentally, coffee stained diskettes and diskettes with staples driven through them don't qualify as "defective".)

**WE WILL MEET OR BEAT ANY NATIONALLY ADVERTISED PRICE ON THE SAME PRODUCTS AND QUANTITIES SUBJECT TO THE SAME TERMS AND CONDITIONS.**

# DISK WORLD!, Inc.

Suite 4806  
30 East Huron Street  
Chicago, Illinois 60611





# SUNTRONICS CO., INC.

12621 Crenshaw Blvd., Hawthorne, CA 90250

NEW BRANCH STORE IN ORANGE COUNTY, CALIFORNIA 17552 BEACH BLVD., #C, HUNTINGTON BEACH, CA 92647 (714) 842-1948

1-800-421-5775 (Order Only)  
 (213) 644-1140 (CA Order & Info.)  
 STORE HOURS  
 Mon.-Fri. 9 a.m. to 6 p.m.  
 Sat. 10 a.m. to 5 p.m.

TERMS: VISA, MASTERCARD, C.O.D. (Cash or Certified Check Required) Check (Allow 2-3 Weeks for Clearing) Shipping & H.C \$3.00 for 3 Lbs. plus 50c for each add'l Lb. Calif. residents add Calif. Sales Tax \$10.00 Minimum Order. IBM and Apple are registered trade marks of IBM & Apple.

## IBM XT Compatible Products

CPU Board (w/128K)	\$399.00
Computer Cabinet	\$69.00
83 Key Full-Function Keyboard	\$99.00
Monochrome Graphic Card (w/parallel printer port)	\$210.00
130 Watt Power Supply	\$129.00
135 Watt Power Supply	\$135.00
150 Watt Power Supply	\$140.00
Color Graphic Card	\$149.00
FDD Controller Card	\$99.00
Parallel Printer Card	\$59.00
ASYNC & RS232 Card	\$75.00
360KB DSDD (Slimline) Disk Drive	\$119.00
IBM Parallel Cable	\$19.00
IBM Prototype Board	\$9.00
Apparat EPROM Blaster	\$129.00
MicroLog Z-80B Baby Blue II Co-Processor, Multi-Function (Run CP/M Software, Require 64K RAM)	\$499.00
IBM Up-Grade Kit (4164-150NS)	\$19.50 per kit
10MB Hard Disk (w/Controller)	\$675.00
IBM PC Mouse	\$147.00
Quad Board II	\$249.00
Quad 512 (w/64K RAM)	\$259.00
Koala Graphics Table (w/Software)	\$105.00
Keyboard Extension Cable	\$9.00

## Apple Compatible Products

Sun Z80 Card (w/o Software APPLE II & II+ only)	\$49.00
Sun 80 Column Card (w/Soft Switch)	\$85.00
Power Supply (5 Amp)	\$59.95
Cooling Fan	\$42.00
Floppy Disk Controller	\$42.00
16K RAM Card	\$49.00
128K RAM Card	\$159.00
Parallel Printer Card	\$49.00
Serial Printer Card	\$89.00
RS232 Card for Modem	\$99.00
EPROM Programmer (2716,32,64)	\$75.00
Apple Disk Drive (Full height)	\$159.00
Apparat EPROM Blaster	\$119.00

## SPECIAL SALE ITEMS

S-100 Single Board Computer (Z80A)	Kit \$99.00 B/B \$49.00
S-100 Universal Floppy Disk Controller	Kit \$125.00 B/B \$49.00
S-100 Clock/Calendar Kit	\$89.00 B/B \$42.00
S-100 64K Static Memory Board (w/o RAM)	Kit \$89.00 B/B \$49.00
S-100 Prototype Board (Sun-721)	\$9.95
12" Amber TTL Hi-Res Monitor (20mHz)	\$135.00
12" Green TTL Hi-Res Monitor (20mHz)	\$129.00
12" Green Composite Hi-Res Monitor (22mHz)	\$99.00
SKC DS/DD 5 1/4" Diskette	\$14.95 per 10

# WAVE MATE BRINGS MUSCLE TO YOUR IBM PC/XT WITH IT'S 80286 MOTHERBOARD

**BULLET-286 makes the XT perform with greater power and speed than the IBM PC/AT**

It's the new **BULLET-286** motherboard for the IBM PC/XT marketplace. This advanced-technology product utilizes the Intel microprocessor 80286 while maintaining both hardware and software compatibility with the IBM PC/XT. By simply replacing the existing XT board with our new **BULLET-286**, you get greater power and speed than the IBM PC-AT. Thus, existing PC/XT users can preserve their investment in hardware and software while moving a quantum leap beyond PC-AT performance.

The **BULLET-286** contains a 6 megahertz no wait state 80286 microprocessor in place of the XT's 4.77 MHz 8088. There is an 80287 math co-processor option, 8 IBM expansion slots, and enhanced ROM BIOS. The **BULLET-286** is equipped with 256K bytes of

memory, expandable to 1 megabyte on-board.

The **BULLET-286** is compatible with the IBM PC/XT to a degree far beyond the IBM PC-AT product. Application programs and operating systems (PC-DOS, CP/M, UCSD Pascal, Pick, Oasis, Unix-derivatives) available for the XT, can run without incompatibilities on the **BULLET-286**.

You can order now. The **BULLET-286** is available with 256K RAM, with options to 1 full megabyte. Prices start at \$1,995.

Quantity discounts available. OEM and dealer inquiries welcome.

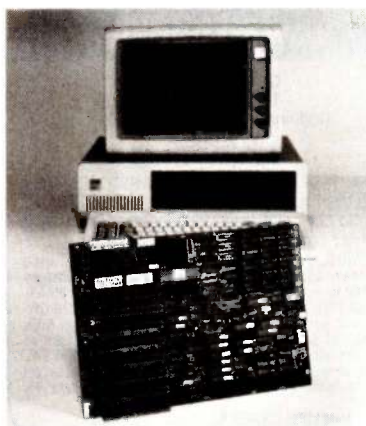

## APOLLO MARKETING

(a division of Cal. Digital)

22048 Sherman Way #316  
 Canoga Park, CA 91303  
 Tel: (818) 883-8390 Telex: 194369  
 In Europe call: Brussels 649-1070  
 Telex 61828

# ALL PRICES 20%-40% OFF LIST

**COMPUTER CONNECTION**  
TOLL FREE ORDER LINE

## PRINTERS

<b>OKIDATA</b>	
ML 182A, Replaces 82A "New" .....	\$ 239
ML83A, 15" Para. & Ser. ....	545
ML92P, 160 cps .....	355
ML92 IBM Graphics Comp. ....	355
ML92S, 160 cps .....	465
ML92 Apple Mac. 2K Graphics .....	475
ML93P, 160 cps .....	579
ML93 IBM Graphics Comp. ....	579
ML93S, 160 cps .....	769
ML84P, 200 cps .....	679
ML84S, 200 cps .....	779

## STAR MICRONICS

SG-10, 120 cps, 2K buffer .....	\$ 249
SG-15, 120 cps, 2K buffer .....	399
SD-10, 160 cps, 10" carriage .....	369
SD-15, 160 cps, Corr. Qual. ....	479
SB-10 Draft & NLQ 24 wire printhead	799

## C. ITOH

7500 AP w/tract. (better than RX80) ..	\$ 225
Prowriter 8510 AP, 120 cps .....	299
Prowriter 8510 BC2, 120 cps .....	389
Prowriter 8510 SP, 180 cps .....	399
8510 BPI (IBM Compatible) .....	335
Prowriter II 1550 P, 15" 120 cps .....	449
Prowriter II 1550BCD, 15" 120 cps .....	439
1550 SP, 180 cps .....	445
Starwriter F10-40PU, 40 cps .....	525
Starwriter A10-30 .....	889
Printmaster F10-55PU, 55 cps .....	1029

## BROTHER

HR25, 25 cps .....	\$ 669
HR35, 36 cps .....	839

## DYNAX

DX15XL, 20 cps By Brother .....	\$ 379
---------------------------------	--------

## JUKI

6100, L.Q. 18 cps w/proportional spc. \$	399
6300 .....	699

## TOSHIBA

P1351 Dot Matrix, 192 cps, letter quality	100 cps, does graphics, 3 in 1 printer
P1340 same as above but 10" carr. ....	685

## PANASONIC

1091 w/Tractor, 120 cps, 1 yr. war. ....	\$ 279
1092 .....	439
1093 .....	669

## LEGEND

880, 80 cps, FT & Graphics .....	\$ 229
1080, 120 cps, FT & Graphics .....	275

## DISK DRIVES

<b>TANDON</b>	
TM100-2 for IBM PC .....	\$ 119

## ALPHA OMEGA

10 Meg HD for IBM & Comp. w/Cont. Card	\$ 1199
13 Month Warranty .....	775

## TEAC

55B Double Sided 360K .....	\$ 109
Quad Density .....	189

## MPI

55S Dbl/Dbl for IBM .....	\$ 78
---------------------------	-------

Drives For Apple & Franklin

## RANA SYSTEMS

Elite I .....	\$ 199
Elite II .....	339
Elite III .....	389
Controller add .....	75

## MICRO-SCI

A-2 .....	\$ 175
A.5C for IIC w/cable .....	189
A.5 1/2 height for IIE .....	199
Controller Add .....	70

## PRINTER ACCESSORIES

<b>ORANGE MICRO</b>	
Grappler + .....	\$ 115
Buffered Grappler +, 16K exp. 64K ..	159

<b>TOSHIBA</b>	
Bi-Directional Tractor .....	\$ 149
Font Disk for Down loading P1351 ..	48

<b>MICROTEK</b>	
Dumpling GX (same as Grappler +) ..	\$ 69
Dumpling GX w/16K buffer .....	135
Dumpling GX w/32K buffer .....	147
Additional Buffering 16K .....	12

<b>FOURTH DIMENSION</b>	
Par. Card & Cable for Apple .....	\$ 47

<b>OKIDATA</b>	
Plug and Play for IBM .....	\$ 49
Okigraph I for 82A/83A .....	49
Tractor for 82A & 92 .....	49

<b>JUKI</b>	
Bi-Directional Tractor .....	\$ 125
Serial Interface .....	65

<b>CABLES</b>	
IBM PC to Parallel Printer .....	\$ 18
Serial Cable .....	18

## EASTER SPECIALS!!

<b>APPLE PROF. SYSTEM</b>	
All Apple .....	\$1375

<b>BUF. GRAPPLER +</b>	
.....	\$159

<b>MICRO-SCI A-2</b>	
.....	\$175

<b>C.ITOH 8510 AP</b>	
.....	\$299

<b>APPLE SUPER SERIAL</b>	
.....	\$135

<b>ANCHOR MARK XII</b>	
.....	\$218

## DISPLAY MONITORS

<b>QUADRAM</b>	
Amber chrome IBM compatible .....	\$ 175

<b>AMDEK</b>	
V300G .....	\$ 125
V300A .....	135
V310A for IBM PC .....	159
Color600 .....	429
Color710 .....	545

<b>TAXAN</b>	
IBM Green Monochrome #121 .....	\$ 139
IBM Amber Monochrome #122 .....	145
RGB IBM w/Cable #420 .....	419
RGB Super Hi-Res. #415 .....	393
RGB Super Hi-Res. #440 .....	499
RGB/Comp. Med. Res. #210 .....	259

<b>PRINCETON GRAPHICS</b>	
HX-12 for use with IBM PC .....	\$ 455
Max 12 Amber for IBM .....	179
SR 12 Super Hi-Res .....	595
Scan Doubler .....	185

<b>X-TRON</b>	
AG-12, 1000 x 450 Hi-Res w/lt. swvl. \$	130
AA-12, 1000 x 450 Hi-Res w/lt. swvl. \$	135

<b>TEAC 55B</b>	
.....	\$109

<b>PARADISE MOD. G. C.</b>	
.....	\$269

<b>VUTEK COLOR CARD</b>	
2 yr. war. ....	\$175

<b>OKIDATA ML92 IBM</b>	
.....	\$355

<b>HAYES 1200</b>	
.....	\$435

<b>TAXAN No. 440</b>	
.....	\$449

<b>MPI DRIVE FOR IBM</b>	
.....	\$78

## IBM PC ACCESSORIES

<b>IBM</b>	
IBM Dos 3.0 .....	\$ 69
IBM Tech Ref. for PC .....	85

<b>PARADISE</b>	
Modular Graphics Card .....	\$ 269
Module A .....	79
Module B .....	189

<b>64K MEMORY UPGRADE</b>	
64K (9 chips) .....	\$ 17

<b>AST RESEARCH</b>	
Six Pak + w/64K .....	\$ 239
Preview .....	Call

<b>QUADRAM</b>	
Quad Color 1 Board .....	\$ 199
Exp. Quadboard w/64K .....	239
Quadlink 3000 Run Apple sft on IBM ..	359

## APPLE & FRANKLIN ACCESSORIES

<b>ACCESSORIES</b>	
Kensington System Saver .....	\$ 69
Fan for Apple II & IIE w/surge .....	37

<b>APPLE</b>	
Super Serial Card .....	\$ 135

<b>ASTAR</b>	
RF Modulator .....	\$ 17

<b>VUTEK (2 yr. war.)</b>	
Vutek - CPS Board, RGB & Composite	w/Par. & Ser. Ports, 2 Yr. War. ....
Color Card (Herc. comp.) .....	175
Monographic Card (Herc. comp.) .....	275

<b>PERSYST BOARD</b>	
Bob Hi-Res Display Adaptor .....	\$ 399

<b>KEYTRONICS</b>	
KB5151 .....	\$ 185

<b>ORCHID</b>	
Blossom .....	\$ 245

<b>DATA PLUS</b>	
384K Mem. Board w/OK .....	\$ 119
XT Short Card, 384K Mem. ....	185

<b>ADVANCED LOGIC SYSTEMS</b>	
Z Engine 2.2 .....	\$ 119

<b>MICROMAX</b>	
Viewmax 128K extended 80 col. card	for Apple IIE .....
80 col. card for Apple II & II + .....	139

<b>MICRO-SCI</b>	
64K, 80 Col. Card .....	\$ 85

GIVE US A CHANCE TO BEAT THE COMPETITION'S ADVERTISED PRICE. IF YOU SEE IT ADVERTISED FOR LESS, CALL COMPUTER CONNECTION FIRST FOR LOWEST QUOTE!

MAIL ORDER:  
17121 S. Central Avenue, Unit L  
Carson, California 90746



NO SURCHARGE FOR CREDIT CARDS

We accept VISA, MasterCard, COD (w/deposit), Certified Checks or Wire Transfers. Minimum Shipping Charge \$4.00. Some items subject to back order. California Res. add 6 1/2% Sales Tax. All returns are subject to a 15% restocking charge and must be authorized by store manager within 10 days. Prices subject to change without notice. This Ad supersedes all others.

## PERSONAL SYSTEMS

<b>APPLE</b>	
Professional Sys. incl: Apple IIE w/128K & 80 col. tilt mon., duo disk w/con't kit. \$	1375
Apple IIC Lightweight Portable .....	Call

<b>IBM</b>	
IBM PC Bare w/cont. & keyboard .....	\$1150
IBM PC 64K, 1 Drive .....	1325
IBM PC 64K, 2 Drives .....	1499
IBM PC, 2 Drives w/256K .....	1599
IBM XT, 128K, 10 Meg., 360K Dr. ....	3495
IBM AT Base .....	Call
IBM AT Enhanced .....	Call

<b>Call About All "AT" Systems</b>	
------------------------------------	--

<b>SANYO</b>	
MBC 550-2 w/1 320K Drive & sftwr. ....	\$ 895
MBC 555-2 w/2 320K Drives & more software .....	1075
Portable .....	Call
Serial Port for Sanyo .....	79

<b>TAVA</b>	
TAVA PC1 Par. & 1 Ser. Ports, 128K, 2-320K	Drives, Color Card & Monitor .....
.....	\$1499

<b>COMPAG</b>	
256K, w/2 - 320K Drives .....	\$2150

<b>SOFTWARE</b>	
<b>LOTUS DEVELOPMENT CORP.</b>	
Lotus 1-2-3 .....	\$ 295
Symphony .....	437

<b>ASHTON TATE</b>	
D Base III .....	\$ 419

<b>PRINTER SWITCH BOX</b>	
<b>EXPONENT</b>	
Centronics Two Switch .....	\$ 89
Centronics Four Switch .....	125
Serial Two Switch .....	79
Serial Four Switch .....	115

<b>MODEMS</b>	
<b>ANCHOR</b>	
Mark XII .....	\$ 225
Volksmodem XII .....	185

<b>HAYES MICRO</b>	
300 Baud Smart Modem .....	\$ 205
1200 Baud Smart Modem .....	435
1200 B for IBM PC .....	379
2400 Baud Modem .....	645
Micro Modem IIE .....	259
Chronograph .....	189

<b>DISKETTES</b>	
<b>PC DISKETTES</b>	
Sgl./Dbl. (Box of 10) .....	\$ 16
Dbl./Dbl. (Box of 10) .....	18

<b>COMPUTER CONNECTION</b>	
Sgl./Dbl. (Box of 10) .....	\$ 14
Dbl./Dbl. (Box of 10) .....	16
Sgl./Dbl. w/Disk Container (10) .....	20
Bulk 50 & Up - Dbl./Dbl. ....	1.35 ea.
5 yr. warranty	

<b>ORDER LINE</b>	
<b>(800) 732-0304</b>	
(Outside California)	
<b>(213) 635-2809</b>	
(Inside California)	

<b>Mon.-Fri. 7 a.m. to 6 p.m.</b>	
<b>Saturday 11 a.m. to 3 p.m.</b>	

<b>CUSTOMER SERVICE:</b>	
<b>(213) 635-5065</b>	
<b>Mon.-Fri. 9 a.m. to 3 p.m.</b>	

**COMPUTER CONNECTION**

MOST ORDERS SHIPPED SAME DAY



# COASTLINE COMPUTERS

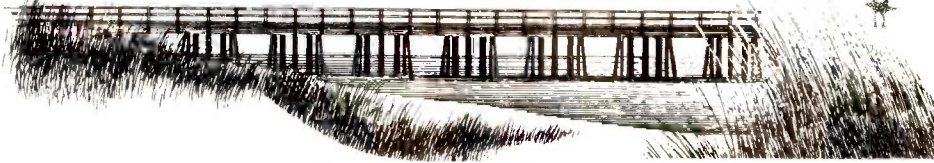

CALL COLLECT-FREE  
**213-329-4828**  
**213-324-8087**

1956 W. 153 St., Gardena, CA 90247

## CONFIGURED SYSTEM SPECIALISTS

ALL SYSTEMS INCLUDE NECESSARY CABLES AND ALL ARE TESTED BEFORE SHIPPING

*Please specify type of drives, speed of RAMs, type of monitor interface when ordering*

### IBM PC

- 2 55B Teac 1/2 High Drives
- 256K, BMC 13" Amb Mon.
- Monitor Interface

**\$1895**



### IBM PC

- 2 Full Height MPI Drives
- Keyboard & Dr Controller
- 256K Memory

**\$1549**

### IBM EXECUTIVE SYSTEM

- IBM PC w/256K
- 2 Half High Drives
- 8087-3 Math Coprocessor
- Monochrome Monitor
- Mono Card w/Par Port
- DOS 2.1 Operating System
- Okidata 92P Dot Matrix Printer (160cps)

**\$2399**

### IBM PC

- 2 Half High Epson Drives (with 2 Year Warranty)
- 256K (150nS) Memory
- Color Monitor w/Interface

**\$1939**

### IBM PRO EXECUTIVE SYSTEM

- IBM PC w/256K
- 2 360K 1/2 High Dr w/Cont
- 10 Meg Internal Hard Disk
- Monochrome Monitor
- Mono Card w/Par Port
- DOS 2.1 Operating System
- Juki 6100 Letter Quality Printer (18cps)

**\$3495**

Sav-On May Have Lower Over All Prices But No One Can Save You More  
 On These Selected Items Than Coastline Computers

<p><b>INTEL</b>  <b>Math Coprocessor</b>  <b>8087-3</b>                      (FOR IBM PC AND COMPATIBLES)  <b>\$109.00</b>                      Call for 8087 for IBM AT</p>	<p><b>AST SIXPAC +</b>                      Comes with 384K                      Expandable                      Clock Calendar, Par/Ser Port                      Plus Software  <b>\$239.00</b></p>	<p><b>IBM Memory Upgrade</b>                      For IBM &amp; Compatibles                      9 - 4164                      64K Upgrade <b>\$19.95</b>                      128K Upgrade <b>\$40.95</b></p>
<p><b>IBM CABLE</b>                      Computer to Par Printer                      6 Foot Long  <b>\$14.50</b></p>	<p><b>BMC</b>                      13" Amber Monitor  <b>\$89.00</b></p>	<p><b>IBM DOS 2.1</b>                      IBM PC &amp; XT                      Operating System  <b>\$54.99</b></p>
<p><b>QUANTITY ORDERS</b>                      Call for Bigger Discounts                      Corporate &amp; School Accts                      Call for Information                      Dealer Programs Avail - P.O.s Expedited</p>	<p><b>HERCULES</b>  <b>GRAPHICS CARD</b>                      Monochrome w/Par Port                      For IBM &amp; Compatibles  <b>\$319.00</b></p>	<p><b>Other Product Lines</b>  <b>Available from Coastline</b>                      Amdek • Princeton Graphics • Techmar • Teac                      Hercules • Compaq • Tandon • NEC • Intel                      Okidata • Quadram • Hayes • Alpha Omega                      Anchor • Bizzcomp • Juki • Epson • Plus More!</p>

Mail Orders To: 1956 W. 153 St., Gardena, CA 90247. Terms: Visa, Mastercard, COD;s and Wire Transfers. No surcharge for credit cards. UPS, Federal and Emery shipping available. Calif. residents add 6 1/2% sales tax. Prices subject to change without notice. Not responsible for typos.





SINCE 1977

# Computer Discount Products

Monthly Mail-Order Listing  
For Apple, IBM & Macintosh Users

Retail Showrooms In California:  
San Jose • San Mateo • San Francisco

**WE PAY SHIPPING\***  
Get The Details Below!!

### INFOCOM

Apple, IBM & Macintosh

CUTTHROATS/ENCHANTER	ea27.99
DEADLINE/SUSPECT	ea34.99
INFIDEL/SORCERER	ea31.99
HITCHHIKER/SEATALKER	ea27.99
WITNESS/ZORK I	ea27.99
ZORK II/ZORK III	ea31.99

<b>MOCKINGBOARD IIc</b> With Speech & Sound	<b>169.99</b>
<b>QUADVUE NEW!</b> Monochrome Card	<b>259.99</b>

### ENTERTAINMENT

Ap BEAGLE I.O. Silver - NEW!	SCALL
Ap DECATHLON	23.99
Ap SIR TECH Knight of Diamond	27.99
Ap WIZPLUS	23.99
IBM GATO	29.99
IBM MASTERTYPE	34.99
IBM SIR TECH Wizardry	44.99
Ap/IBM CHAMP. LODERUNNER	24.99
Ap/IBM ELECTRONIC ARTS Archon	31.99
Ap/IBM Music/Pinball Const.	ea31.99
Ap/IBM One On One/Sky Fox	ea31.99
Ap/IBM SIR TECH Simulator	37.99
Ap/IBM SARGON III	34.99
Ap/IBM TRILLIUM Amazon/Fama	ea29.99
Ap/IBM Fahrenheit 451/Shadow	ea29.99
Ap/IBM WINDHAM Below The Root	18.99
Ap/IBM Swiss Family Robinson	18.99

### APPLICATION Home & Business

Ap ASCII Express	99.99
Ap CONTINENTAL Hm. Acct.	44.99
Ap Home Accountant MAC	75.99
Ap Tax Advantage	39.99
Ap MONOGRAM Dollars & Sense	79.99
Ap PFS Rept. File, Graph, Write	ea84.99
IBM ASCII Express Pro	139.99
IBM ASHTON-TATE dBase II	299.99
IBM dBase III	449.99
IBM Framework	399.99
IBM CONTINENTAL FCM	71.99
IBM Home Accountant	84.99
IBM Tax Advantage	49.99
IBM CROSSTALK	139.99
IBM LOTUS 1-2-3	299.99
IBM MICRO PRO Telmerge	119.99
IBM MONOGRAM Dollars & Sense	109.99
IBM PFS Rept. File, Graph, Write	ea99.99
Ap/IBM MICRO COOKBOOK	31.99
Ap/IBM MICROSOFT MULTIPLAN	169.99
MAC MULTIPLAN/FILE	ea149.99
MAC PFS Report. File	ea89.99

### WORD PROCESSING

Ap BANK STREET Write/Spell	ea44.99
Ap MICROPRO Wordstar	279.99
Ap Wordstar Pro w/CP-M	349.99
Ap SENSIBLE SPELLER	89.99
Ap SIERRA Screenwriter II	89.99
IBM BANK STREET Writer	59.99
IBM LIFETREE Volkswriter Deluxe	199.99
IBM MICROSOFT Word w/Mouse	299.99
IBM MICROPRO Wordstar 2000	259.99
IBM Wordstar 2000 Plus	359.99

### MODEMS

HAYES 300 Baud	209.99
1200B for IBM	409.99
Micromodem IIc	239.99
NOVATION Appecat II 300 Bd.	249.99
Expansion Module	29.99
J Cat	109.99

### HARDWARE

Ap ALSZ-Engine	134.99	Ap TITAN Accelerator I/c	259.99
Ap CDP 16K Ram Card	39.99	Ap Neptune 64K	199.99
Ap Parallel Interface w/Cable	39.99	Ap Saturn 64K Ram	279.99
Ap DAN PAYMAR Lower Case 1	25.99	IBM AST Six Pack Plus 64K	279.99
Ap Lower Case 2, Rev 7	19.99	IBM KENSINGTON PC Saver	29.99
Ap EXTENDED 80 Cal. Card-I/c	129.99	IBM KOALA Touch Pad	95.99
Ap KENSINGTON System Saver	65.00	IBM PLANTRONICS Color + Board	375.99
Ap KOALA Touch Pad	85.99	IBM QUADRAM 512 + 64K	229.99
Ap MICRO-SCI A-2 Drive	199.99	IBM ERam 80	129.99
Ap MICROSOFT Ram Card	74.99	IBM Microfazer 8K-All Config.	149.99
Ap Softcard	229.99	IBM Quadboard I or II-No K	219.99
Ap ORANGE MICRO Grappler +	114.99	IBM Quadcolor I	209.99
Ap Buffered Grappler	179.99	IBM Quadcolor Upgrade to II	209.99
Ap THUNDERCLOCK	109.99	IBM TEAC 1/2 Height Drive #55B	159.99

### UTILITIES & ENHANCEMENTS

Ap BEAGLE D/Code - NEW!	SCALL
Ap Beagle Graphics	44.99
Ap Dos Boss	17.99
Ap Fat Cat	26.99
Ap GPL	32.99
Ap Triple Dump	31.99
Ap BRODERBUND Dazzle Draw	44.99
Ap Graphics Library	19.99
Ap Print Shop	39.99
Ap COPY II Program	25.99
Ap EASTSIDE Wildcard II	111.99
Ap FONTRIX	59.99
Ap FINGERPRINT For Epson	44.99
Ap MERLIN	44.99
Ap MOCKINGBOARD	89.99
IBM COPY II Program	25.99
IBM FONTRIX	99.99
IBM NORTON UTILITIES	55.99
IBM SIDEKICK	41.99
Ap/IBM TURBO PASCAL	41.99
MAC COPY II Program	25.99

### APPLE PRE-BOOTS

Apple Writer	14.99
Apple Writer for Ultraterm	23.99
Visicalc	39.99
Visicalc w/Memory Expansion	66.99
Visicalc for Ultraterm	54.99

### VIDEX-Apple

ENHANCER II	99.99
FUNCTION STRIP	31.99
HARDSWITCH	14.99
PSIO	169.99
SOFTSWITCH	25.99
ULTRATERM	244.99
VIDEOTERM w/Softsw.	219.99

### FOR IBM

Get Organized	149.99
Sideways	44.99

### MACINTOSH MICROSOFT

Basic	109.99
Chart	99.99

**USI Pi4**  
20mhz Amber Monitor  
For Apple **99.99**

MAXELL 5 1/4 SS 10/100	19.99/189.
MEMOREX 3 1/2 SS 10/100	41.99/399.
MEMOREX 5 1/4 SS 10/100	18.99/179.
FLIP-FILE Holds 50-5 1/4	14.99
MEDIA MATE Holds 30-3 1/2	11.99

### EDUCATIONAL

#### DLM

Ap Alien Addition/Minus Mission	ea22.99
Ap Alligator Mix/Dragon Mix	ea22.99
Ap Division/Multiplication	ea22.99

#### LEARNING COMPANY

Ap Bumble Games/Plot	ea27.99
Ap Gertrudes Puzzle/Secret	ea29.99
Ap Rockys Boot/Robot Odyssey	ea34.99
Ap/IBM Addition Magician/Word Spinner	23.99
Ap/IBM Magic Spell/Number Stump.	ea27.99
Ap/IBM Moptown Hotel/Reader Rabbit	ea27.99

PEACHTREE ALGEBRA I-IV	ea29.99
ALGEBRA V & VI	ea34.99

#### SPINNAKER

Ap Grandmas House/Kidwriter	ea24.99
Ap Kids On Keys	19.99
Ap Sum Ducks	24.99
Ap Trails	27.99
Ap/IBM Facesmaker/Fraction Fever	ea24.99
Ap/IBM Diddle Diddle/Kindercomp	ea19.99
Ap/IBM Presidents Choice	27.99
Ap/IBM Snooper Troops I or II	ea31.99

#### COLLEGE BOUND - Apple

BARONS SAT	59.99
CBS Mastering SAT	149.99
PEACHTREE SAT	37.99
PEACHTREE PSAT	37.99

# Computer Discount Products

860 So. Winchester Bl., San Jose, CA 95128

(408) 985-0400 FROM 8AM PST

Inquiry 82

NO CHARGE FOR CREDIT CARDS • GUARANTEED FAIR PRICING

Purchase Order Prices Differ - Call First • Prices Subject To Change • Software Sales Final  
PLEASE ALLOW TIME FOR PERSONAL CHECKS TO CLEAR

ORDER # B4

**\* ALL SOFTWARE SHIPPED  
FREIGHT-FREE**  
U.S. Mail - \$10 Minimum Chg.  
Hardware Shipping - \$CALL

FULL DEALER SUPPORT  
VISIT OUR SHOWROOM  
Hrs. 8:30AM - 5:00PM M-F

Cashiers Check/M.O. P.O.'s from qualified firms. APO accepted. Shipping: minimum \$4. first 3 Lbs. Tax: AZ Res. Only add 6% sales tax. All returns subject to 20% restocking fee. Advertised prices for Mail Order Only. Retail prices slightly higher. Prices subject to change.

Inquiry 338 for Dealers.  
Inquiry 339 for End-Users.





**TEAM New Hayes SmartModem Compatible! TEAM**  
 Finally a price breakthrough on a Hayes compatible, external 300/1200 baud modem. This low price is without driver software. But if you need it add \$25.00.  
 • Hints the popular Hayes communications software • PC support for direct B.L.L.I. connections

**IBM Call We**  
 ★ Hardw ★  
 Call ★

**IBM PC FLOPPY DISK SYSTEM**  
 Basic system includes 256K, two floppy drives 360K each, drive controller and keyboard

**IBM PC 10MB SYSTEM**  
 Basic system includes 256K, one floppy drive, keyboard, 10MB Hard Disk with controller (boots from hard disk)

We have not given System prices due to continuous changes in the PC market and our policy of having the best prices and availability. Simply COMPARE our peripheral prices and for even greater savings **CALL FOR LATEST SYSTEM PRICES ...**

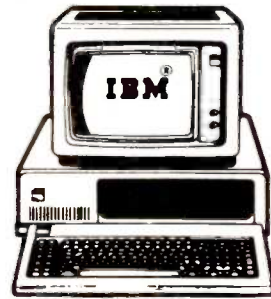

**IBM PC 20MB SYSTEM**  
 Basic system includes 256K, one floppy drive, keyboard, 20MB Hard Disk with controller (boots from hard disk)

**IBM PC 30MB SYSTEM**  
 Basic system includes 256K, one floppy drive, keyboard, 30MB Hard Disk with controller (boots from hard disk)

Choose from the widest selection of enhancement products for your IBM PC system at the best prices. Start with the Basic system and configure it according to your needs. All Hard Disk systems are available with 2 floppy drives. All IBM Systems come only with **COMPUMAIL's 90 day warranty.**

## ★ PRICE WAR ★ CALL US LAST WITH YOUR BEST QUOTES ★

PRINTERS	
<b>EPSON</b> RX-80	\$229 FX-80 + \$389
RX-80FT +	\$279 FX-100 + \$569
LQ-1500 Parallel	\$1099 Serial \$1199
LQ-1500 Tractor/Cutsheet Feeder	\$550/\$399
NEW JX-80 COLOR	CALL
<b>OKIDATA</b> 92P/93P/84P	\$349/\$559/\$669
<b>NEW OKIMATE</b> 20 Color w/Plug & Print	CALL
<b>NEW</b> 182P Personal Printer	CALL
<b>TOSHIBA</b> 1340P	\$669
<b>TOSHIBA</b> 1351P	\$1199
<b>JUKI</b> 6100/6300	\$379/\$699
<b>BROTHER</b> HR-15 XL (20 CPS)	\$329
HR-25 (23 CPS)	\$549 HR-35 (36 CPS) \$749
Tractor/Sheet Feeder for HR-25/35	\$119/\$199
M-1009	\$199 2024L LQ/Graphics \$999
2024L Cutsheet Feeders - Narrow	\$199 Wide \$249
<b>C. ITOH</b> 8510-BPI	\$309 8510-SEP \$379
8510-SCEP	\$439 1550-EP \$429
1550-P	\$449 1550-SEP \$529
F-10 (40 CPS)	\$859 F-10 (55 CPS) \$1049
<b>QUME</b> LETTERPRO 20P\$429 SPRINT 1140 +	\$1299
SPRINT 1155 +	\$1499 1190 + CALL
INTERFACE MODULES Centronics/Serial/IBM Par	\$80
<b>NEC</b> P-2	\$649 P-3 \$899
2050	\$669 3550 \$1299 8850 \$1699
<b>DIABLO</b> 630 ECS/IBM	\$1799 630 API \$1599
Advantage D-25	\$549 620 API \$729
DATA PRODUCTS	
SPG 8051 (Same as IBM Color Printer)	\$1399
SPG 8071 (Same as 8051 at twice the speed)	\$1799

HARD DISKS/BACKUP	
<b>HARD DISKS/BACKUP for IBM PC</b>	
10 MB HD	\$599 20 MB HD \$899
10 MB Tape Backup	\$599 Larger HD & Backups CALL
TALL GRASS NEW PC/T FORMAT	
25 MB w/60 MB	\$2799 35 MB w/60 MB \$3599
50 MB w/60 MB	\$4399 80 MB w/60 MB \$5999
Controller	\$140 Cartridge(60 MB) \$35
<b>QUBIE</b> 10/20 MB Internal or External	CALL
<b>KAMERMAN</b> Masterflight w/10, 20 or 30 MB HD and 10, 20 or 60 MB streamer tape backup w/controller cards, 5 plug power control, surge protection and lock. Call for <b>BEST</b> price for your <b>RIGHT</b> combination.	
<b>MAYNARD</b> 10MB/WS-1 \$849 10MB/WS-2 \$969 30MB/WS-1A \$1999 30MB/WS-2A \$2099	
MaynStream - Complete cartridge backup system	CALL
<b>AMPEX</b> PC Megastore 20MB w/25MB stmr	CALL
<b>SYSGEN</b> 10MB tape backup	\$799
QIC File - 45MB tape backup - Int/Ext	\$1195/\$1295
10 MB/20 MB Hard Disc w/streamer tape backup	CALL
<b>GENIE</b> Fixed/Removable Systems	Entire line

MODEMS	
<b>MICROCOM</b> ERA-2 Int. w/software	\$359
<b>HAYES</b> 1200 B Internal w/software	\$369
1200 Standalone w/o software	\$419
<b>NEW</b> 2400 Baud	CALL
<b>POPCOM</b> C-100/X-100	Special Low Prices
<b>PROMETHEUS</b> PROMODEM 1200 Ext.	\$319
PROMODEM 1200B Internal w/software	\$275
<b>NOVATION</b> Access 123 Int. w/Crosstalk	\$399
<b>NEW</b> Smart Cat Plus w/MITE software - Int. or Ext.	\$349
<b>VENTEL</b> Half Card 1200 for short slot	\$419
<b>QUBIE</b> Standalone	\$309 Internal \$279
<b>BIZCOMP</b> Intellimodems XL/XT/ST	CALL

MONITORS	
<b>PGS</b> MAX-12 Amber-Monochrome (800x350)	CALL
HX-12 (690x240)	\$429 SR-12 (690x480) \$599
COLOR CARD for SR-12 (single slot)	CALL
<b>TAXAN</b> COMPOSIT 115 Grn/116 Amber	\$139
MONO 121 Green/122 Amber (1000x360)	\$159
411 (510x260)	\$349 425 (640x262) \$449
440 (720x400)	\$549 W/Persyst BoB Brd \$969
<b>AMDEK</b> 300G/300A/310A (M)	\$139/\$149/CALL
COLOR 600 (640x240)	\$429 710 (720x480) CALL
<b>SAMSUNG</b> Mono-Grn/Amber	\$129
<b>QUADRAM</b> AMBERCHROME (720x350)	CALL
QUADCHROME II (640x240) Color Graphics & Text	\$429

FLOPPY DISKS	
<b>TEAC</b> Half Ht FD 55B - DSDD	\$109
<b>CDC</b> Full Ht/Half Ht - DSDD	\$139
<b>IBM</b> Full Ht - DSDD	\$159
<b>TANDON</b> 100-2 Full Ht/Half Ht-DSDD	\$119/\$99

MULTI-DISPLAY CARDS	
<b>EVEREX</b> Graphics Edge	Best Price Ever
<b>AST</b> Monograph Plus w/clock, PP & Serial	\$399
<b>PERSYST</b> BoB Board	\$449
<b>MYLEX</b> Mono/Color Graphics & printer port	\$449
<b>PARADISE</b> Modular Brd	\$269 Modules CALL
<b>INTELLIGENT</b> B-450 Mono/Color/printer	\$249
<b>TECMAR</b> Graphics Master w/PC Paintbrush	\$449
<b>HERCULES</b> MonoGraphics	\$299 Color \$159
MULTI-FUNCTION CARDS	
<b>AST</b> SIXPAK w/64K	\$245 Exp. to 384K \$375
<b>QUADBOARD</b> O-K	\$219 Exp. to 384K \$369
<b>ORCHID</b> Blossom O-K	\$195 Exp. to 384K \$345
<b>BT 6 PLUS</b> (like sixpak) w/64K	\$219 Exp. to 384K \$349
<b>IDS</b> B-512 w/64K	\$219 Exp. to 512K \$399

EMULATION BOARDS	
<b>ORCHID's</b> PCturbo 186 (128K to 640K)	Best Prices
IRMA/IRMAline/IRMAPrint	\$859/\$929/\$929
IRMALette \$299 IRMAline/IRMALette Package	\$999
<b>CXI</b> 3278/79 PLUS PC Connection	Coax or Modem version
<b>CXI</b> 3270 PC Connection	CALL

★ SUPER SPECIALS ★	
<b>64K RAM</b> Set of 9 Chips	\$20
<b>AST</b> SIXPAK w/64K	\$245 Exp. to 384K \$375
<b>HAYES</b> 1200B w/sft	\$369 1200 Ext \$419
<b>HARD DISK</b> 10 MB/20 MB	\$599/\$899
<b>OKIDATA</b> 92P	\$349 93P \$559 84P \$669
<b>TOSHIBA</b> 1340P	\$669 1351P \$1199
<b>ORCHID</b> PCturbo 186 w/640K	\$1099
<b>BROTHER</b> HR-15 XL (20 CPS)	\$329
HR-25 (23 CPS)	\$549 HR-35 (36 CPS) \$749
<b>HERCULES</b> MonoGraphics	\$299 Color \$159
<b>8087-3</b> Math Chip for IBM PC (Intel)	\$129
<b>IBM's</b> original PC Keyboard	\$129

MISC. ADD ONS	
<b>8087-3</b> Math Chip for IBM PC (Intel)	\$129
Floppy Drive Controller for IBM PC	\$119
<b>CABLE</b> Parallel	\$20 Serial \$25
Keyboard Ext, 6 ft.	\$10 Smart Cable CALL
<b>DISKETTES</b> DSDD TOP BRAND Box of 10	\$25
<b>QUBIE</b> Keyboard 5150	\$119 5151 \$149
<b>KEYTRONIC</b> Deluxe Keyboard KB 5151	\$159
<b>TOOL KIT</b> 8 piece set in a convenient pack	\$29
<b>TILT/SWIVEL</b> Monitor Base	\$30
<b>PC</b> Keyboard Storage Drawer	\$89
<b>KENSINGTON</b> Master Piece (5 Outlets)	\$109
<b>COMPUTER ACCESSORIES</b> P2 (5)	\$109
<b>POWER DIRECTOR</b> P22 (4) \$79 P12 (6) \$149	
<b>STANDBY PWR SUPPLY</b> w/surge protection	200 Watts \$279 300 Watts \$379 800 Watts CALL
<b>KOALA</b> Touch Tablet w/software	\$89

**COMPANY POLICY:** Min order \$100. Prices & availability subject to change. We ship UPS. Shipping/handling charges vary. COD requires cash, money order, cashier or certified check. Personal & Company checks take 3 weeks to clear. No refunds. 20% restocking fee on all returns. Compumail credit issued for balance. Call for return authorization. After repairs/returns. No open acct. PD's or foreign orders. For advance payment or PICKUP. Please call first for workorder number.

**MasterCard** **VISA** **AMERICAN EXPRESS**

NO SURCHARGE ON COD, VISA or MC. AMEX 5%



# Sav-On Computers 800-345-7100

ORDERS INSIDE CALIF — 213-675-2115

CUSTOMER SERVICE & TECHNICAL HELP — 213-675-2382

## PRINTERS

**STAR MICRONICS**  
 GEMINI 10X (120cps) ..... \$249  
 GEMINI 15X (120cps, 15" Car) ... 389  
**OKIDATA**  
 82A (120cps, 10", par/ser.) ..... \$309  
 92A (160cps, parallel) ..... 349  
 93A (160cps, parallel) ..... 599  
 84P (200cps, parallel) ..... 789  
 OKI PLUG & PLAYS AVAILABLE Call

**EPSON**  
 RX80  
 RX80FT  
 FX80  
 TRACTORS  
 OTHER EPSON PRODUCTS AVAIL.  
 Call Prices  
 Much Lower  
 Than Your  
 Authorized Dealers

**JUKI**  
 6100 (18cps & let. quality) ..... \$409  
 6300 (40cps, 16", comes with  
 3K Buffer, Upgrade to 15K) ..... 789  
**BROTHER** ..... Call  
**DYNAX** ..... Call  
**NEC** ..... Call

## MONITORS

**PRINCETON GRAPHICS**  
 HX12 (12" Color RGB/TTL, High  
 Res, 690x240 lines, 15MHz) ..... \$449  
 SR12 (12" Color RGB/TTL, High  
 Res, 690x480 Lines, 25MHz) ..... 599  
 MAX12 (12" Monochrome TTL,  
 960ctr Lines, 18MHz) ..... 179  
 SCAN DOUBLER ..... 199

**AMDEK**  
 300 (13" Color Composite,  
 300x260 Lines, 4MHz) ..... \$259  
 300A 12" Composite Amber, High  
 Res) ..... 139  
 310A (12" Monochrome, TTL) ..... 179  
 COLOR II+ (13" RGB/TTL, 560x240  
 Lines, 18MHz) ..... 399  
 500 (13" Color RGB/Composite/TTL,  
 320x240 Comp., 560x240 RGB,  
 12MHz) ..... 419  
 600 (RGB/TTL, 640x240 Lines,  
 16MHz, 16 Colors) ..... 419  
 710 (13" RGB/TTL, 720x480 Lines,  
 18MHz, 16 Colors) ..... 549

**ZENITH**  
 ZVM122 12" Amber ..... \$99  
 ZVM123 12" Green ..... 99  
**LEADING EDGE**  
 GORILLA 12" Green ..... \$98  
 GORILLA 12" Amber ..... 98

**TAXAN**  
 121 (12" Green) ..... \$108  
 122 (12" Amber) ..... 109

**NEC**  
 JB1201 (12" Green Composite,  
 800ctr Lines, 20MHz) ..... \$129  
 JB1205 (12" Amber Composite,  
 800ctr Lines, 20MHz) ..... 129  
 OTHER MONITORS IN STOCK Call

## Sav-On Sysms - Your Systems House

### APPLE PRO SYSTEM

CPU w/64K and Drive Controller  
 2 Drives, 80 Col Card (extended),  
 Apple Green Monitor & Stand

**\$1349.00**

### IBM PC SYSTEM

w/2 Drives, 256K Memory  
 Monitor (Grn/Amb), Mon. Interface

**\$1699.00**

### Sav-On APPLE COLOR

Apple 64K Computer, Ext 80 Col  
 Card, Amdek Color Mon., Dual Dr

**\$1529.00**

### IBM XT SYSTEM

256K Mem. w/2 1/2 High 360K Dr.  
 10 M Hard Disk, Amdek 310A Mon  
 Monitor Interface w/Par Port

**\$3850.00**

### COMPAQ

2 Drives with 256K, Portable

**\$2095.00**

### IBM PC COLOR SYS

256K, 2 360K Dr. Hercules Clr Crd  
 Princeton HX12, All Cables

**\$2075.00**

### COMPAQ PLUS

1 Dr & 10M Internal **\$3395**

## DISKETTES

**DYSAN**  
 5 1/4" DS/DD (Box of 10) ..... \$28

## MODEMS

**HAYES**  
 300 ..... \$199  
 1200 External, PC Compatible ..... 469  
 1200B Internal, PC Compatible ..... 399  
 MICRO MODEM IIe ..... 239  
**NOVATION** ..... Call  
 ACCESS 123 ..... Call  
 J-CAT ..... Call  
 APPLE CAT ..... Call  
**ANCHOR**  
 MARK VII (300 Baud) ..... \$99  
 MARK XII (1200 Baud) ..... 239  
 MARK VI ..... 69  
 CALL FOR PRICING ON  
 OTHER MODEMS

## APPLE ADD-ONS

**TG**  
 JOY STICK ..... Call For  
 SELECT PORT ..... Lowest  
 PADDLES ..... Prices  
**MICROMAX**  
 VIEWMAX 80 ..... \$130  
 VIEWMAX 80e ..... 130  
**KENSINGTON**  
 SYSTEM SAVER ..... \$69  
 MORE AVAILABLE ..... Call

## PRINTER INTERFACE and PERIPHERALS

**PRINTER CABLES**  
 ALL MAKES (9 foot long) ..... \$18  
**FOURTH DEMINION**  
 PAR CARD & CABLE for Apple ..... \$48  
**ORANGE MICRO**  
 GRAPPLER + ..... \$119  
 GRAPPLER + w/16K ..... 169  
**OKIDATA**  
 SERIAL INTERFACE ..... \$89  
**MICRO TEK**  
 DUMPLING GX ..... Call  
 BAM 16 ..... Call

## IBM PC SYSTEMS

IBM PC w/o Drives, 64K and Drive Controller ..... \$1299  
 IBM PC 64K, 1 360K Drive, Controller (Handles 4 Drives) ..... 1429  
 IBM PC 256K, 2 360K Drives and Controller ..... 1450  
 All IBM's include keyboards, all necessary cables, manuals and 90 warranty  
 IBM PC XT 128K, 1 360K Dr and 1 Internal 10M Hard Disk ..... 3395  
 IBM AT (Base Model) 256K, 1.2M Floppy, Clk Cal, 8 Exp Slots + more ..... 3849  
 IBM AT (Enhanced) 512K, 1.2M Floppy, 20M Hard Drive, Ser/Par Ports ..... 5495  
 IBM PC JR (All IBM Product Drive, Monitor, RAM) ..... Call for Price

**IBM**  
 PC, XT Operating Sys 2.1 ..... \$59  
 AT Operating Sys 3.0 ..... 69  
 MONOCHROME MONITOR ..... 239  
 COLOR MONITOR ..... 589  
 COLOR CARD, HX12 (IBM Comp) 189  
 MONO CARD w/Par Print Port ..... 229  
 PC Par or Ser Print Port ..... 73 ea

## DRIVE CONTROLLER CARDS

IBM Original (Controls 4 drives) ..... \$139  
 MAYNARD (Any Configuration) ..... Call  
 IBM Copy (120 Day Warranty) ..... 119

## PC COMPATIBLE DRIVES

CDC (IBM Compatible) ..... \$159  
 TANDON Full Height 320K ..... 159  
 MPI A2 (IBM Compatible) ..... 119

## TALLGRASS HARD DISKS

20, 35 or 70Mbyte w/Back-up ..... Call  
 MAYNARD, ALPHA OMEGA, GENIE  
 CALL FOR PRICING

## L.D.C.

LOTUS 123 & SYMPHONY ..... Call

## AST

SIX PAC PLUS (1 Ser/1 Par Port,  
 Clock w/0 memory) ..... \$239  
 SIX PAC PLUS (1 Ser/1 Par Port,  
 Clock & 64K exp. to 384K) ..... 249  
 SIX PAC PLUS (1 Ser/1 Par Port,  
 Clock & 384K Memory) ..... 409  
 I/O PLUS (1 Ser & 1 Clock) ..... 129  
 I/O PLUS (1 Ser/1 Par & Clock) ..... 165  
 MEGA PLUS (64K) ..... 269  
 MEGA PAC (128K) ..... 269  
 MEGA PAC (256K) ..... 349  
 OTHER AST BOARDS AVAILABLE  
 CALL FOR PRICES

## QUADRAM

COLOR 1 ..... \$199  
 COLOR 2 & QUADBOARDS ..... Call

## HERCULES

MONOCHROME (Hi Res Graph) ..... \$329  
 COLOR CARD ..... 199

## TECHMAR

GRAPHICS MASTER (Runs Mono &  
 Color, High Res in Both Modes) ..... \$459

## STB

GRAPHICS (PLUS) II Supports Both  
 Color and Mono Display. .... \$339

## PC PEACOCK

COLOR BOARD with Par. Port ..... \$209

## PLANTRONICS

COLOR PLUS ..... 339

## KEYTRONICS

5151 Keyboard w/Sep Num. Pad ..... Call  
 5150 Keyboard ..... Call

## INTEL 8087-3 5MHz

Math Coprocessor for PC and Compatibles

1pcs. \$139 ea. 5pcs. \$125 ea. 10pcs. \$120 ea.  
 (Also available for AT, 8087-8MHz and 8087)

## RAM CHIPS — 64K \$25.95

All RAM Chips are compatible 1000pcs \$1.90  
 with IBM XT/compatible machines. 5000pcs \$1.85  
 Japanese and American Brands 10000pcs \$1.80

## DISK DRIVES

TEAC 55B 360K 1/2 High DS/DD Drives for IBM  
 1pcs. \$119 ea 10pcs. \$113 ea 15pcs. \$109 ea  
 TANDON 100-2 360K Full Height DS/DD Drives  
 1pcs. \$145 ea 5pcs. \$140 ea 10pcs. \$132 ea

FINANCING AVAILABLE—with approved credit

DEALERS: Open Accounts available, call for applications

TERMS: We accept VISA, MASTERCARD, COD's, and Wire  
 Transfers. UPS, Federal Express and Emery shipping available.  
 California residents please add 6 1/2% sales tax to order. Prices  
 are subject to change without notice. Not responsible for  
 typographical errors.

# Sav-On Computers, Inc.

12595 Crenshaw Blvd., Hawthorne, CA 90250

OPEN: 7:30am till 6:00pm Monday-Friday and 9:00am till 2:00pm Saturday

Inquiry 344



**ICs PROMPT DELIVERY!!!**  
SAME DAY SHIPPING (USUALLY)

OUTSIDE OKLAHOMA: NO SALES TAX

**DYNAMIC RAM**

256K	256Kx1	150 ns	\$ 7.15
128K	128Kx1	150 ns	15.67
64K	64Kx1	150 ns	1.79
64K	64Kx1	200 ns	1.97

**EPPROM**

27256	32Kx8	250 ns	\$26.97
27128	16Kx8	250 ns	9.97
27C64	8Kx8	200 ns	8.75
2764	8Kx8	250 ns	4.29
2732A	4Kx8	250 ns	4.87
2716	2Kx8	450 ns	3.21

**STATIC RAM**

6264LP-15	8Kx8	150 ns	\$10.70
6116LP-3	2Kx8	150 ns	3.43

INCREASE XT MOTHERBOARD TO 640 Kbyte  
CONSUME NO EXPANSION SLOTS! \$181.80

QUANTITY ONE PRICES SHOWN

OPEN 6 1/2 DAYS: WE CAN SHIP VIA FED-EX ON SAT

MasterCard/VISA or UPS CASH COD  
**Factory New, Prime Parts**

**MICROPROCESSORS UNLIMITED**

24,000 South Peoria Ave. (918) 267-4961  
BEGGS OK 74421

Prices shown above are for March 11, 1985  
Please call for current prices. Prices subject to change. Please expect higher or lower prices on some parts due to supply & demand and our changing costs. Shipping & insurance extra. Cash discount prices shown. Small orders shipped by 5 PM CST. Call usually delivered to you by the next morning, via Federal Express Standard Air. \$6.50

Inquiry 265

Serial ◀■■■■■■▶ Parallel

**NEW!**



**Convert What You Have  
To What You Want!**

- \* RS232C Serial
- \* 8 Baud Rates
- \* Latched Outputs
- \* Centronics Parallel
- \* Handshake Signals
- \* Compact 3 1/4" x 4 1/4" x 1 1/2"

No longer will your peripheral choices be limited by the type of port you have available! Our new High Performance 700 Series Converters provide the missing link. Based on the latest in CMOS technology, these units feature full baud rate selection to 19.2K, with handshake signals to maximize transfer efficiency. Detailed documentation allows simplified installation. Order the Model 770 (Ser/Par) or Model 775 (Par/Ser) Today!

only \$89.95

Buffer Products Coming Soon!

**Tigertronics** INCORPORATED  
2734-C Johnson Dr.  
Post Office Box 3717  
Ventura, California 93006

Connector Option \$10.00  
CA Residents 6% tax  
UPS Shipping \$3.00

CALL (805) 658-7466 or 658-7467  
For FAST Delivery

Inquiry 142



**ISOBAR...cleans up your line power! The most complete computer protection available!**

More features to prevent errors, false print-out, disc skips! *Only IsoBar has 3-way spike protection, noise suppression for RFI plus isolated filter banks!* Prevents components in your system from interfering with each other and erratic line power from damaging the system!

Models \$55 to \$98. Free brochure.  
**CALL TOLL FREE 1-800-662-5021 or write:**  
**INDUS-TOOL, Dept. BT**  
325 W. Huron, Chicago, IL 60610

Inquiry 197

**ZENITH/Heath Users**

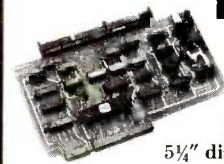

**Double Your 5 1/4" disk storage capacity without adding a drive.**

Get twice as much from your H88 or H89 microcomputer. Our FDC-880H floppy disk controller, in conjunction with your 5 1/4" drives, for example, expands memory capacity from 256 bytes to 512 bytes per sector.

And it handles single and double-sided, single and double-density. 8" and 5 1/4" drives — simultaneously.

  
C. D. R. Systems Inc.  
Controlled Data Recording Systems Inc.  
7210 Clairmont Mesa Blvd., San Diego, CA 92111  
(619) 560-1272

Inquiry 62

**IBM PC / VT100**  
EM100  
for IBM PC, XT, AT  
APRICOT and VICTOR 9000

VT102 emulation, English setup menu, 110-9600 BAUD, ASCII file transfer, Modem 7 binary transfer, 132 columns, soft keys, and more! *Optional Tektronix 4010 emulation.*

Multicopy discounts

 **Diversified Computer Systems, Inc.**  
100 Arapahoe, Boulder, CO 80302  
(303) 447-9251  
Dealer inquiries invited.

Trademarks: VT100-Digital Equipment; IBM PC, XT-IBM Corp. VICTOR 9000-Victor Technologies. COMPAQ-COMPAQ Computers, Inc.

Inquiry 125

**HARD DISK BOOT + DATA SECURITY**

*FiXT ends boot hassles, stops data thieves—*

**DATAMAC, DAVONG, GREAT LAKES, IOMEGA, XEBEC, ZOBEX, others.**

No-Slot Installation for  
**IBM PC, COMPAQ, COLUMBIA**  
\$70 - \$95 + tax/shpg

 **GOLDEN BOW SYSTEMS**  
Box 3039  
San Diego  
CA 92103  
619/298-9349

Inquiry 171

**DISK DRIVES**

Half Height  
IBM Compatible

**ONE YEAR WARRANTY**

40 tr. DS/DD	.....	\$115.00
80 tr. DS/DD	.....	\$139.00
1.2 meg. floppy	.....	CALL

Enclosures and mounting kits  
Special bracketed pair pricing

IN STOCK \* 2 DAY SHIP

 **ALLIED MICRO DEVICES**  
2809 Boardwalk, Ann Arbor, MI 48104  
(313) 996-1282: TX 2907707 AEML  
\*Manufactured by SANYO

Inquiry 19

**IBM COMPATIBLE**

**DYNA PC 64K BASIC UNIT**

- \* 64K system board
- \* 130W switching power supply
- \* USA made Hi-Tek Keyboard
- \* Case with flip-up top cover

**\$650.00**

**DYNA PC 256K COMPLETE SYSTEM**

- \* 256K system board
- \* Keyboard/130W power supply/case
- \* 2 1/2 Ht. 360K disk/controller
- \* AST 6-PAK compatible board
- \* Hercules compatible board
- \* Color graphic board
- \* Monochrome monitor

**\$1495.00**

**DYNA XT 256K COMPLETE SYSTEM**

- \* DYNA PC 256K complete system
- \* 10MB hard disk (20MB optional)
- \* DTC hard disk controller

**\$2145.00**

\*\*\*\*\*  
OEM and DEALER inquiries invited  
\*\*\*\*\*

**DYNA SYSTEMS**  
1500 Wyatt Drive, Suite 8 Tel: (408) 748-8501  
Santa Clara, CA 95054 Telex: 317994 Dyna Systems

Inquiry 129

 **ROSE DATA SWITCHES**

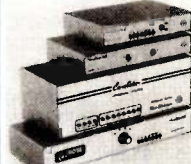

SHARE computers, printers, any parallel or serial device  
ELIMINATE cable swapping  
INEXPENSIVE way to network  
COMPATIBLE with all computers  
Businesses, Schools, Homes

WE ALSO OFFER:  
Data Buffers, Line Drivers, Modems, Protocol Converters, Parallel - Serial Converters, Cables, Computers, Printers, Disk Drives, and more.

**AUTOMATIC - CARETAKER** is ideal for a business or school to share a printer or modem among many computers. Operation is fully automatic with no software required.  
Parallel or Serial - 4 channels - \$295 8 channels - \$395

**MANUAL - HARDSWITCH** is operated with the flip of a switch. 2.2 and 2.4 models allow simultaneous communication.  
Serial 1:2 - \$59 1:4 - \$ 99 2:2 - \$109 2:4 - \$169  
Parallel 1:2 - \$99 1:4 - \$159 2:2 - \$189 2:4 - \$279  
LED and spike protection on serial models add \$20.

**CODE ACTIVATED - PORTER** connects one computer to multiple peripherals. A software code selects the peripheral.  
Parallel or Serial - 4 channels - \$295 8 channels - \$395  
Buffer option 64K - \$100 256K - \$250

**REMOTE - TELEPATH** connects multiple computers to multiple peripherals. A selector at each computer or terminal chooses up to 4 peripherals and displays busy status.  
4:4 - \$495 4:8 - \$795 selector - \$39

Give a Rose to your computer

**ROSE ELECTRONICS (713) 240-7673**  
P.O. BOX 740571 MC & VISA Accepted  
HOUSTON, TX 77274 Dealer Inquiries Invited  
**CALL US FOR ALL YOUR INTERFACE NEEDS**

Inquiry 337



# PRIORITY ONE ELECTRONICS

VIASYN™ CompuPro

& COEX

**The Perfect S-100 Team!**  
CPU-Z  
64K Low-

**The Z80 Standard**  
6MHz Z80B CPU  
24 Bit Addressing  
**BOTH BOARDS  
PURCHASED  
TOGETHER:**

**\$299**

**BPVIACOX (Sh. wt. 3 lbs.)**  
**BPGBT160A CPU Board Only: \$179.00**  
**BPCOX64KRAM 64K RAM Only: \$179.00**

**100MHz  
Dual Trace  
Dual Time-  
Base**

BK PRECISION

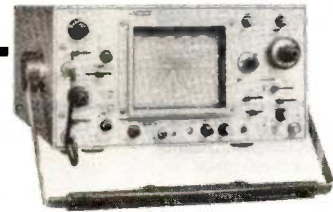

**PRICE  
BREAK  
THROUGH!**

**PROBES INCLUDED!**

**\$995**

**BPBKP1580**  
List Price:  
\$1595.00

**NOW OPEN - SAN JOSE (408) 946-7010**

## 64K & 256K Memory Expansion Sets

- 64K Expansion, Contains **BPP0B1MMEM0**  
9 64K x 1 150nS RAMs **\$18.00**
- 256K Expansion, Contains **BPP0B1MMEM36**  
36 64K x 1 150nS RAMs **\$59.95**
- 256K Expansion, Contains **BPP0B25MEM0**  
9 256K x 1 RAMs **\$89.00**

## IBM AT™ Compatible Hard Disk Drive

Description	Part no.	Price
20Mbyte hrd disk formatd SEAGATE 518	BPS5EAST25F	\$ 795
33Mbyte IBM color video card 21bs	BPIBM1504910	\$ 250
IBM Monochrome Card 21bs	BPIBM1504900	\$ 250

## IBM-PC™ COMPATIBLE MONITORS

- TAKAN 12 green screen for IBM 181bs
 BPTAX121 | \$ 169 |

## STD CARDS

- Super RIO i64K
 BPS7S10 | \$ 319 |

## PARADISE

- 5 Pkg. Multicolor card 384K
 BPPARS3ACK384 | \$269 |

## TECMAR BOARDS

- The CAPTAIN™ Multi board 64K
 BPTCECAPTAIN | \$ 259 |

## HERCULES GRAPHIC CARDS

- High res monochrome card
 BPHEGC | \$ 339 |

## QUADRAM CARDS

- EXPANDED QUADBOARD 10 K
 BPDQRDRDXP0 | \$ 239 |

## VIDEO MONITORS

- SANYO 12MHz 12 Amber 18 lbs
 BPSYDM2212 | \$ 79 |

## MICRO COMPUTER ACCESSORIES

- Keyboard Software, 100k 10 lbs
 BPMCA510 | \$ 89 |

## KEYTRONICS

- IBM PC™ replacement keyboard 1 lb
 BPKKEYBS151 | \$199 |

## MODEMS

Description	Part No.	Price
<b>HAYES</b>		
1200 Baud Smartmodem 4 lbs	BPDCH0400P	\$ 429
1200 Baud for IBM-PC™ w/software	BPDCH1200B	\$ 429
300 Baud Smartmodem	BPDCH200P	\$ 249
Micromodem II for Apple	BPDCH701400	\$ 249

## PROMETHEUS

ProModem 1200 baud auto dial/ans 4 lbs	BPPRMPM1200	\$ 299
ProModem IBM-PC™ card w/software	BPPRMPM1200B	\$ 289
ProModem Apple II card w/software	BPPRMPM1200A	\$ 349
ProModem for Macintosh w/cable & software	BPPRMPM1200M	\$ 399
Alphamium display for ProModem	BPPRMDISPLAY	\$ 79
Options processor for ProModem	BPPRMDOPTRO	\$ 79
64K Memory exp. for options processor	BPPRMDMEMX64	\$ 59

## DISK DRIVES

<b>SIEMENS Single side dbl density 181bs</b>		
2 to 5 Drives \$110 each / 6 or more Drives \$99 each	BPSIEFD01008	\$ 125
<b>WORLD DISK DRIVES Double side</b>		
dbl density 181bs	BPW0D2008P	\$ 219
2 to 5 Drives \$199 each		
6 or more Drives \$189 each		
<b>MITSUBISHI dbl side, dbl dens 181bs</b>		
2 to 5 Drives \$110 each / 6 or more Drives \$99 each	BPMITM28463B	\$ 375
TANDON 1/2 height 3 1/2 inch 960K 91bs	BPNOTM8401E	\$ 319
TANDON 1/2 height dbl side, dbl dens 91bs	BPNOTM8402E	\$ 389

## 5 1/4" DRIVES

SHUGART 40rk 1/2 height, dbl side 31bs	BPSHUSA455	\$ 99
SHUGART 40 rk 1/2-in dbl side 31bs	BPSHUSA465	\$ 99
TANDON 100-2 40rk full height, dbl side 41bs	BPNOTM1002	\$ 149

## 5 1/4" HARD DISK

QUANTUM 42Mbyte Hard disk 91bs	BPQIM0540	\$1385
Seagate ST725 1/2 high 25Mbyte 51bs	BPSSEAS725	\$ 695
MAXTOR 85Mbyte 30ms access 121bs	BPMXTX1085	\$2385
MAXTOR 140Mbyte 30ms access 121bs	BPMXTX1140	\$3665
SHUGART SA712 12 Mbyte	BPSHUSA712	\$ 399

## PRINTERS & BUFFERS

Description	Part no.	Price
<b>EPSON</b>		
NOW SHIPPING NEW → SERIES		
RX80 201bs	BPEPRX80+	\$ 239
RX80FT 201bs	BPEPRX80FT+	\$ 279
RX100 201bs	BPEPRX100+	\$ 429
FX80 201bs	BPEPRFX80+	\$ 399
FX100 261bs	BPEPRFX100+	\$ 599
LD1500 Ser int 30cps	BPPDBEPLD1500S	\$1249
LD1500 Par int 30cps	BPPDBEPLD1500P	\$1199

## OKIDATA

82A w/tractor feed 25 lbs	BPKOIDAT82AT	\$ 349
83A w/tractor feed 35 lbs	BPKOIDAT83AT	\$ 589
84A - parallel 35 lbs	BPKOIDAT84AP	\$ 895
84A - serial 35 lbs	BPKOIDAT84AS	\$ 979
92A - parallel 25 lbs	BPKOIDAT92AP	\$ 469
92A - serial 25 lbs	BPKOIDAT92AS	\$ 610
93A - parallel 35 lbs	BPKOIDAT93AP	\$ 699
93A - serial 35 lbs	BPKOIDAT93AS	\$ 925

## MANNESMANN TALLY

MT160L 80 col 21 lbs	BPTALMT160L	\$ 575
MT180L 132 col 28 lbs	BPTALMT180L	\$ 799

## TOSHIBA

P1340 serial 301bs	BPTSHP1340S	\$ 649
P1340 parallel 301bs	BPTSHP1340P	\$ 649
P1351 parallel 351bs	BPTSHP1351P	\$1299
Bi-direction tractor for P1351 61bs	BPTSHPA0303	\$ 195
Single bin auto sheet feeder for P1351 151bs	BPTSHPA05002	\$ 995

## PRACTICAL PERIPHERALS

64K Microbuffer (serial) 21bs	BPPRPMB1564	\$ 249
64K Microbuffer (parallel) 21bs	BPPRPMB1P64	\$ 249
Microbuffer II+ for Apple (ser & par) 2 lbs	BPPRPMB2PLUS10	\$ 189

## S-100 CPU BOARDS

Shipping weight on all S-100 boards 21bs, each

Description	Part no.	Price
CompuPro CPU-Z	BPGBT039	\$ 179
CompuPro 8085/88 dual processor	BPGBT041	\$ 399
SDS SBC 300 6MHz	BPSDS38095	\$ 599
SDS SBC 300 6MHz	BPSDS38092	\$ 599
ADVANCED DIGITAL SuperSix w/kcopy controller, 128K RAM	BPAACSU6128	\$ 699
ADVANCED DIGITAL 4MHz SBC, 5 1/4" floppy controller, 64K RAM	BPAACSD8C15	\$ 595
ADVANCED DIGITAL 4MHz SBC, 8" floppy controller, 64K RAM	BPAACSD8C18	\$ 595

## S-100 RAM BOARDS

CompuPro RAM23 / 64K	BPGBT0316	\$ 349
CompuPro RAM 23 / 128K	BPGBT0319	\$ 599
SDS ExpandRAM III/696	BPSDS38097	\$ 499
SDS ExpandRAM IV	BPSDS38088	\$ 825
MACROTECH 1 Megabyte	BPMACMAAM	\$2195
CompuPro RAM 22 / 256K	BPGBT0470	\$1199

## S-100 RAM DISK BOARDS

CompuPro M-Drive/II 512K	BPGBT0472	\$ 695
SDS RAM disk 256K	BPSDS38082	\$ 549

## S-100 I/O BOARDS

Vector Interface II	BPVCIB000F2B	\$ 259
CompuPro Interface 3	BPGBT0319	\$ 599
CompuPro Interface 4	BPGBT0400	\$ 349
CompuPro System Support 1	BPSCSA1003	\$ 350
SDS 4 port Async, serial	BPSDS38096	\$ 449
SDS 8 port Async, serial	BPSDS38093	\$ 529
SDS 8 port 4-Async, 4-sync	BPSDS38094	\$ 649

## S-100 CONTROLLER BOARDS FOR FLOPPY DISKS

CompuPro DISK I DMA	BPGBT54018	\$ 399
CompuPro DISK I/A DMA	BPGBT0408A	\$ 549
SDS VersaFloppy II with CP/M 3.0™ (a special implementation by SDS)	BPPDFV2CPM3	\$ 299
SDS VersaFloppy III	BPSDS38099	\$ 599
with 5 1/4" unbanked CP/M 3.0™	BPPDFV339145	\$ 749
with 8" unbanked CP/M 3.0™	BPPDFV339146	\$ 749
with 5 1/4" banked CP/M 3.0™	BPPDFV339147	\$ 749
with 8" banked CP/M 3.0™	BPPDFV339148	\$ 749

## FOR HARD DISK

CompuPro DISK3 Seagate ST500 series	BPGBT0407	\$ 599
ADVANCED DIGITAL Seagate 500 compatible	BPAOCHDC1015	\$ 399

## DISK DRIVE ENCLOSURES 8" ENCLOSURES

Paradynamics dual desktop 351bs	BPPND200D	\$ 479
Paradynamics dual rack mount 351bs	BPPND200R	\$ 499
JMR Dual desktop 301bs	BPMJMR208	\$ 229

## 5 1/4" ENCLOSURES

JMR Single 51bs	BPMJMR105	\$ 59
JMR Dual full height 91bs	BPMJMR205	\$ 89
JMR Dual full height w/internal data cable 91bs	BPMJMR205C	\$ 99
JMR Dual half height vert. mount 71bs	BPMJMR205V	\$ 65
JMR Single hard disk enclosure 161bs	BPMJMRDC51	\$ 199
JMR Dual hard disk enclosure 201bs	BPMJMRDC52	\$ 299

**5" Double Sided Double Density Diskettes** **Nashua Diskettes**

**\$1.20 EACH in Packs of 50**  
BPDS050 (\$1.20 X 50 = \$60.00/pack)  
(Sh. wt 1 lb. per pack)

**\$1.00 EACH in Boxes of 250**  
BPDS0250 (\$1.00 X 250 = \$250.00/box)  
(Sh. wt. 8 lbs. per box)

**95¢ EACH in Cartons of 1000**  
BPDS01000 (\$ .99 X 1000 = \$990.00/carton) (Sh. wt. 30 lbs.)

Diskettes are packaged with Tyvek sleeves, reinforced hubs, labels and write protect tabs. To receive these low-price prices, you must order in exact multiples shown here.



**PRIORITY ONE ELECTRONICS**

9161 Deering Ave., Chatsworth, CA 91311-5887



**ORDER TOLL FREE (800) 423-5922 - CA, AK, HI CALL (818) 709-5111**

MINIMUM PREPAID ORDER \$25.00. Terms U.S. VISA, MC, BAC, Check, Money Order, U.S. Funds ONLY. CA residents add 6 1/2% Sales Tax. Include MINIMUM SHIPPING & HANDLING of \$3.00 for the first 3 lbs., plus 50¢ for each additional pound (30¢ if within California). Orders over 70 lbs. sent freight collect. Just in case, include your phone number. Prices subject to change without notice. We will do our best to maintain prices through April, 1985. Credit card orders will be charged appropriate freight. We are not responsible for typographical errors. Sale prices are for prepaid orders only. Inquiry 314

**ORDER TOLL FREE (800) 423-5922 - CA, AK, HI CALL (818) 709-5111**



<b>Dysan</b>		100	20
		Qty	Qty
5 1/4	SS DD 104/1D	1.97	2.10
	DS DD 104/2D	2.66	2.82
8	SS SD 3740/1	2.50	2.65
	DS DD 3740/2D	3.18	3.36

<b>maxell</b>		★ Fast Delivery	
5 1/4	SS DD MD1	1.74	1.86
	DS DD MD2	2.29	2.44
8	SS DD FD1	2.79	2.95
	DS DD FD2	3.07	3.24

<b>Things</b>		5 1/4	8
Color Coded Labels (Pkg. of 20)		.25	.30
Tyvek Envelopes ea		.08	.12
10 Disk Soft Box ea		.32	—

**CALL 818-706-8602**  
★ Credit For USA Direct Dial Call With Any Disk Order. ★

**Disks 'n Things**  
5505 Softwind Way  
Agoura Hills, CA 91301  
Free Price List Available

Inquiry 120

**SAVE! SAVE! SAVE!**

**IBM PC 25% off**  
256K, 1 Floppy Drive  
Disk Controller Keyboard

**WE CUSTOMIZE IBM PC SYSTEMS**

HERCULES COLOR CARD	\$168.
AST SIXPACPLUS W/64K	250.
PGS-MAX 12	169.
EPSON FX-100	596.

**ALL SYSTEMS ARE CONFIGURED AND TESTED AT NO EXTRA CHARGE**

OKIDATA 92	390.
TEAC 55B - Floppy Drive	129.
MICRO SCIENCE 10MB	685.
MICRO SCIENCE 20MB	1025.

Call For Additional Prices

**5K Computers**  
1000 Semoran Boulevard/Suite 505  
Winter Park, FL 32792  
1-800-432-8515 Ex 5118  
1-800-624-3250 Outside Florida

Inquiry 162

**Quelo™ 68000** Software Development Tools

**68000/68010 Assembler Package**  
Assembler, linker, object librarian and extensive indexed typeset manuals.  
Conforms to Motorola structured assembler, publication M68KASM(4). Macros, cross reference and superb load map, 31 character symbols.  
Optimized for CP/M-80, -86, -68K, MS-DOS, PC-DOS \$ 595  
Portable Source written in "C" \$1495

**Complete 68000 Development Package for MS-DOS**  
Lattice 68000 "C" Compiler and Quelo 68000 Assembler Package \$1095

**68200 Assembler Package**  
Assembler and linker for Mostek MK68200.  
Optimized for CP/M-80, MS-DOS, PC-DOS \$ 595

For more information contact **Quelo Inc.**  
2464 33rd W. Suite #173  
Seattle, WA 98199  
Phone (206) 285-2528  
telex II (TWX) 9103338171  
COD, Visa, MasterCard

Inquiry 329

**NEC PRINTERS**

2050	\$ 655
3550	\$1315
8850	\$1685
2010/15/30	\$ 625
3510/15/30	\$1185
8810/15/30	\$1625
Elf 360,370	\$ 399
Pinwriter P-2 (w/Interface & Tractor)	\$ 490
Pinwriter P-3 (w/Interface & Tractor)	\$ 690

**Terms: PREPAID — FREE FREIGHT!!**

**QUALITY PRINTERS**  
8415 Cement City Rd.  
Brooklyn, Michigan 49230  
Phone: 517-592-3749

Inquiry 324

*Expanding the power of the computer...*

**COMPUTER SOFTWARE**  
A Scientific American Book

Written by such leading authorities as ALAN KAY, NIKLAUS WIRTH, and LAWRENCE TESLER, this collection of 10 articles from *Scientific American* undeniably shows that software is to the computer as the score is to the instruments of music. Individual chapters consider the question of the interface between the cerebral and the solid-state circuit that software supplies, while subsequent articles examine software's impact on linguistics, science and mathematics, information management, graphics, process control, and problem solving. Order your copy today. *Paper, 124 pages. \$13.95 (plus \$1.50 for postage and handling). ISBN 7167-1712-3*

**W. H. Freeman and Company**  
4419 West 1980 So., Salt Lake City, UT 84104  
(801) 973-4660



Inquiry 398

**IN STOCK**

**MODEMS**  
All modems listed are Hayes compatible with Free Communications Software

<b>RACAL-VADIC</b>	<b>MAXWELL</b>
300PC 300, PC Internal w/soft	\$ 219
300 V 300, RS232C External	\$ 219
1200 PC 300/1200, PC Internal w/soft	\$ 337
1200 V 300/1200, RS232C External	\$ 369
George Communications Software	\$ 79
<b>HAYES 1200 SMARTMODEM External</b>	\$ 449
<b>U.S. ROBOTICS Password</b>	\$ 305
<b>PROMETHEUS</b>	
Promodem 1200	\$ 334
Options Processor	\$ 79

**DIRECT CONNECT DEVICES**  
P.O. Box 13256, San Luis Obispo, CA 93406

CALL FOR FREE CATALOG   CALL TO ORDER (805) 543-6308

Dealer Inquiries Invited - Many Items Not Listed.

Inquiry 118

**DISKS \$1.00**

DSDD - \$1.39  
IBM PREFORMATTED (360K) \$1.55

QUALITY MEDIA • ANY QUANTITY  
LIFETIME REPLACEMENT GUARANTEE  
HUB RINGS • TYVEC ENVELOPES

Because we buy in huge volume to supply software manufacturers, our prices can't be beat.

**BLACKSHIP**  
COMPUTER SUPPLY

PO Box 883362 • San Francisco, CA 94188  
(415) 550-0512

Add \$3.00 shipping and handling (CA residents add 6.5%) VISA/MC/COD

Inquiry 45

**JUST IN TIME**

**EXSEL INC.**

**30 - 60% SAVINGS on**  
Computers  
Word Processors  
Peripherals

**EXSEL INC.**  
OFFICE EQUIPMENT BROKERS  
800-624-2001 NY (716) 325-5530

Inquiry 147

**MAPIT**

**MAPS ON YOUR PRINTER**

OUTLINE  
SHADED BY REGION  
INTERPOLATED CONTOURING  
TREND SURFACE

MAP FILES FOR AMERICAS, ASIA, AFRICA & EUROPE

FOR IBM PC & COMPATIBLES  
**ONLY \$95**

**QSC BOX 778**  
E. LANSING, MI 48823  
(517) 641-4428

Inquiry 330



Contact us for other low prices on hardware and software.  
Next Day Air Extra

# ALL PRICES INCLUDE FREE SHIPPING IN USA.

Call for latest prices.

**COMPAQ®**

256K, 1/360K drive,  
10 Meg Internal



**\$2995**

Functional equivalent  
to a Compaq Plus.

Now using 3 1/2" shock-mounted Winchester drives.  
The same as used in the Compaq Plus.  
Also available with 2 half-height drives and 10 MEG HD—\$3195.

Or upgrade your Compaq to a Compaq Plus™ equivalent with  
our 3 1/2" shock-mounted Winchester disk kit. Includes Hard  
Disk, Controller, Cables, Manual, Software, and Mounting  
Hardware. One year warranty.

**\$995**

**COMPAQ®**

It simply works better:

**DESKPRO™**

Functional equivalent to  
Compaq Deskpro™  
Model 4.

**\$3895**

Includes Monitor

**640K, One 360K Drive,  
One 10 Meg Internal Hard Drive,  
Tape Backup Unit.**

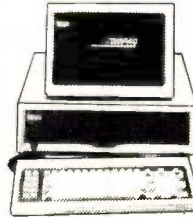

**XT™ POWER 135W**



Solve your power problem.  
Fully XT™ compatible. **\$119**  
One Year Warranty.  
Directly Replaces Power Supply in PC™.

**AT™ PRODUCTS**

Fully compatible w/IBM PC AT™  
Disk Controller, DOS 3.0 or 3.1

128K RAM SET FOR PC AT™

**\$149**

20 MEG Internal Hard Disk

**\$795**

33 MEG Internal Hard Disk

**\$1195**

**IRWIN™**  
MAGNETICS



**TAPE BACKUP SYSTEM**

**\$595**

- Half Height
- Low Power
- Uses Floppy Controller Card
- 10.35 Meg Formatted Capacity
- Used in Compaq Deskpro™

## 10, 20, 33 AND 42 MEG INTERNAL AND EXTERNAL HARD DISK SYSTEMS

With Hard Disk by  
**Microscience  
International  
Corporation®**



Same Hard Drive as used by  
Everex, Qubie™ and Kamerman Labs.

10 Meg Internal

**\$549**

Externals mounted with independent power supply and fan. Fully DOS 2.1 or 3.0 compatible. Both Internals and Externals boot from Hard Disk. 33 and 42 Meg Internal Disks include extender power supply. The system comes complete and ready to install with the Hard Disk, Controller, Cables, Manual, Software, and Mounting Hardware. One year warranty.

	20 MEG	33 MEG	42 MEG
Brand of Hard Disk	Microscience	Rodime	Rodime
<b>Internal</b>	<b>\$695</b>	<b>\$1395</b>	<b>\$1595</b>
<b>External</b>	<b>\$895</b>	<b>\$1495</b>	<b>\$1695</b>

With Hard Disk by

**Shugart®**



Half-Height

Same Hard Drive as used by  
Maynard Electronics.

10 Meg Internal

**\$549**



**TEAC**  
55-B, Half-Height, DS/DD  
**\$109**

**MITSUBISHI**  
(Japan's Best)  
Half-Height, DS/DD  
**\$99**

**PANASONIC**  
JA551-2, Half-Height, DS/DD  
**\$99**  
Same as Shugart SA-455

**64K RAM \$19**

Set of 9 chips, 200 or 150 Nanoseconds

Quantities of 10-49 sets \$17 per set. Quantities of 50-149 sets \$14 per set. Quantities of 150 sets or more \$13 per set.

Set of 9 chips

**256K RAM \$95**

Persyst Time Spectrum  
w/OK—\$189 w/384K—\$303

Compaq 256K, 2 drives—\$2295

**HARDWARE**

CDC 9409 or  
Tandon TM 100-2—\$129

AST SixPak Plus w/384K.....	\$354
AST SixPak w/64K.....	\$259
Hercules Color Card.....	\$175
Hercules Graphics Card w/Parallel.....	\$349
Paradise Modular Graphics Card.....	\$295
Paradise Module A Parallel Port.....	\$ 69
Paradise Module B64-256K/Clock.....	\$209
Persyst Monochrome Card w/Parallel.....	\$175
PGS HX-12.....	\$479
PGS MAX-12.....	\$179
Epson.....	CALL
Juki 6110.....	\$599
Okidata 92/93/84.....	\$369/\$569/\$719
TI 855.....	\$479
Hayes Smartmodem 1200.....	\$449
Hayes Smartmodem 1200B.....	\$369
Keytronic 5151 Keyboard.....	\$189

**dBase III—\$349**

Copy II PC.....	\$24
Copywrite.....	CALL
Disk Explorer.....	CALL
Zero Disk.....	CALL
Prokey 3.0.....	\$89
Sideways.....	\$39
Thinktank.....	\$119

## SOFTWARE

**BORLAND™**  
INTERNATIONAL

Sidekick  
Non-Copy Protected Sidekick  
Turbo Pascal 2.0 or 3.0  
Turbo Pascal w/8087 2.0 or 3.0  
Turbo Pascal w/8087 2.0 or 3.0  
Turbo Toolbox  
Turbo Tutor  
Borland Gift Pack  
Borland Gift Pack w/8087

**CALL FOR PRICES!**

(Our prices are so low, they made us  
take them out of the ad.)

**Norton Utilities—** Version 3.0,  
Dec. '84 Release **—\$59**

Wordstar 2000.....	\$269
Wordstar 2000+.....	\$319
Crosstalk XVI.....	\$119
Multimate.....	\$269
Lotus 1-2-3.....	\$309
Lotus Symphony.....	\$429

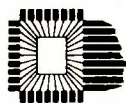

# PC'S LIMITED

**OUTSIDE TEXAS, ORDERS ONLY, CALL 1-800-IBM-5150**

**7801 N. Lamar, #E-200, Austin, Texas 78752**

**All calls inside Texas and all non-order inquiries,**

**call (512) 452-0323**

**Telex No. 9103808386 PC LTD**

Microscience International Corporation,  
Irwin Magnetics, TEAC, COMPAQ,  
Panasonic, Shugart, Mitsubishi, Qubie,  
OKIDATA, IBM, Kamerman Labs, Everex,  
Borland International, and Maynard  
Electronics are trademarks of their  
respective companies. All brands are  
registered trademarks. dBase III is a  
registered trademark of Ashton-Tate.



No surcharge on VISA or MasterCard  
3% surcharge on American Express



## FoxBASE™ Interpreter/Compiler

- dBASE II® source compatible
- Runs 3-20 times faster than dBASE II
- 8087 coprocessor support
- 14 digit precision
- Up to 48 fields per record
- Full type-ahead capabilities
- Provides compact object code and program security
- Twice as many memory variables as dBASE II

### FOX SOFTWARE INC.

13330 Bishop Road, P.O. Box 269  
Bowling Green, OH 43402  
419-354-3981



Inquiry 157

controls up  
to 4 motors  
from any CRT,  
terminal or  
computer



## STEPPING MOTOR CONTROLLER

- powerful 5 amps/ winding
- RS232 interface
- Standard Version with BASIC \$985
- 16K BASIC with Battery Backup \$1335
- CNC VERSION \$1950
- Stepping Motor Tips Cookbook \$8
- CNC Manual \$12
- acceleration deceleration
- 1-4 axis moves

CENTROID (814) 237-4535  
Box 739, State College, PA 16804

Inquiry 63

## NOW C HERE! CROSS SOFTWARE for the NS32000

Also Available for IBM PC

### INCLUDES:

- \* Cross Assembler \*
- \* Cross Linker \*
- \* Debugger \*
- \* N.S. ISE Support \*
- \* Librarian \*
- \* Pascal Cross Compiler \*
- \* C Cross Compiler \*

U.S. prices start at \$500

## SOLUTIONWARE

1283 Mt. View-Alviso Rd.

Suite B

Sunnyvale, Calif. 94089

408/745-7818 • TLX 4994264

Inquiry 357

## PORTABLE EXPANSIONS

### 8K Memory Modules \$44.95

For your Model 100 & NEC PC-8201  
Field proven and fully supported.

### TTXpress Model 1280 Portable Thermal Printer \$170

Bat. operated, 2.2 lbs, 8 1/2" paper, 40 cps

Just for your NEC-8201

### The SideCar \$199

32K RAM cartridge/expandable to 128K

FREE SHIPPING, HANDLING & INS.  
FOR CONT. USA. Orders shipped UPS  
next business day. 30-day satisfaction,  
money back guarantee. We accept Visa,  
M/C & Amer. Exp. Checks held 18 days.

**PURPLE  
COMPUTING**

420 Constitution Ave.  
Camarillo, CA 93010

(800) 732-5012

(805) 987-4788  
(in Calif.)

Inquiry 320

## SAVE TIME AND MONEY WITH LOW COST PI-SWITCH BOXES.

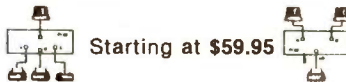

Starting at \$59.95

- Quickly shares your computer among multiple terminals, printers, modems, etc. with just a flick of the wrist.
- Compact black & beige aluminum enclosure features a high quality rotary switch with rear mounted connectors.
- Serial RS-232 Models have fem. 25-Pin Conn. (Lines 1-7 & 20)

- PI-02-S switches 2 to 1 ..... \$59.95
- PI-03-S switches 3 to 1 ..... 79.95
- PI-05-S switches 5 to 1 ..... 109.95
- Parallel models have fem. 36-Pin cent. conn.
- PI-02-P switches 2 to 1 ..... 94.95
- PI-04-P switches 4 to 1 ..... 154.95

- Dealers, schools & custom inquiries welcome.

- One Year Warranty. COD, VISA, M/C.

- Shipping UPS \$2.00/ea. AIR \$4.00/ea.



7301 NW 41 St.  
MIAMI, FL 33166  
(305) 592-6092

Inquiry 340

## GO FORTH, UNIX!

... with u4th

### UNIX/XENIX/FORTH DEVELOPERS

Are you interested in improving your software productivity? Do you have a UNIX system or engineering workstation? Now you can realize the exceptional capability of moving your Forth applications to the world of UNIX and XENIX. Experience the productivity enhancement of an interactive programming environment and still code in C when necessary. Ubiquitous Systems announces u4th, the first Forth completely tailored for UNIX. u4th is a fast direct-threaded Forth written in portable C, yet capable of execution speeds comparable to many assembler Forths. Great for AI research and delivery. Some features are: Access to UNIX utilities and calls / Ability to incorporate C primitives / Object-Oriented Forth included. Binary License Xenix \$395.00 Plexus \$895.00. Call about others' OEM's. Special terms.

### UBIQUITOUS SYSTEMS

13333 Bel-Red Road N.E. Bellevue, Wa. 98005

(206) 641-8030

9:00-noon Weekdays

UNIX/TMI/AT&T

XENIX/TMI/MICROSOFT

Inquiry 391

## 8051 SIMULATOR

for the IBM-PC  
or Z80 CP/M uC

\$199

**SIM51** is a screen oriented program that simulates the Intel 8051 family of single chip microcomputers. It accepts Intel .HEX files (produced by most cross assemblers) and features both a menu and a command driven user interface. Call today for complete information.

### HiTech Equipment Corporation

9560 Black Mountain Road  
San Diego, CA 92126

For Immediate Action Call:  
(619) 566-1892

Inquiry 186

Vertical Mkt.  
Over 135,000  
GAS STATIONS  
Need Specialized  
Bookkeeping Software

## STATION MASTER

Complete integrated system with quick, easy data entry to automatically create daily accounting. Reports shift check-out, TBA, profit & margins. Has full inventory control, AR, Payroll, P/L, many other features. MS-DOS & CP/M versions, fully working demo available.



Small Business  
Computer Systems, Inc.

313 Llewellyn Rd., Ambler, PA 19002 215-542-9639

Inquiry 349



Your  
floppy disk  
should be a  
BASF Flexydisk®

5 1/4"	SINGLE SIDE DOUBLE DENSITY SOFT SECTOR	\$1.39
5 1/4"	DOUBLE SIDE DOUBLE DENSITY SOFT SECTOR	\$1.69
3 1/2"	SINGLE SIDE	\$3.59
	SOLD IN BOXES OF TEN ONLY	
	SOLD IN BOXES OF FIVE ONLY	

tremendous selection of software  
books, accessories and supplies

UP TO 50% OFF!

### Software for IBM PC

dBase III.....	349	Multimate.....	269
Framework.....	349	Symphony.....	419
Home Acct. Plus.....	89	Wordstar 2000.....	279
w/Ultrafile.....	149	Wordstar Pro Pac.....	249

ABOVE SOFTWARE AVAILABLE IN OTHER FORMATS. CALL FOR AVAILABILITY AND PRICE.  
Minimum shipping and handling \$2.00. California residents add 6% sales tax.  
Prices subject to change without notice. Write for our free catalog.

### ABC data products

3311 ADAMS AVE., SAN DIEGO, CA 92116

619-283-5488 ☎ 800-854-1555

Inquiry 8



# computers of New York wholesale

# 315-676-3004

Box 150 Brewerton, N.Y. 13029

Inquiry 92

## We pay UPS shipping charges on prepaid orders.

### —PRINTERS—

<b>ANADEX</b>	
DP-9501B	\$1049
DP-9620B	1099
DP-9625B	1129
DP-6500	2299
<b>TEXAS INSTRUMENTS</b>	
Ti855 w/Tract.	\$839
Ti 810RO Package	Call
<b>C. ITOH</b>	
Prowriter 8510A Par.	\$315
Prowriter 8510A Ser.	415
Prowriter II Par.	499
Prowriter II Ser.	549
<b>EPSON</b>	
RX-80FT	\$329
FX-100	589
<b>STAR MICRONICS</b>	
Gemini 10X	\$259
Gemini 15X	389
Radix 15	Call
<b>MANNESMAN TALLEY</b>	
MT-160 I	\$529
MT-160 L	579
MT-180 L	829
<b>DIABLO</b>	
620 RO 25 CPS	\$879
630 RO 40 CPS	1705
<b>OKIDATA</b>	
ML-82A	Call
ML-83A	Call
ML-92 Par.	Call
ML-92 Ser.	Call
ML 92SA (APPLE)	Call
ML-93 Par.	Call
Pacemark 2350 Ser.	1699
<b>PANASONIC</b>	
KX-P1090	\$279
KX-P1091	329
<b>NEC NEW/NEC 2050</b>	
IBM 2050	\$479 3530 \$1490
3510	1219
3550	1499 8027 359
<b>JUKI</b>	
Daisywheel	\$409
<b>QUME</b>	
Sprint 11/40	\$1299
Sprint 11/55	1499
Sprint 11/90	Call
<b>RITEMAN Inforunner</b>	
	\$299

Advertised prices reflect a cash discount on prepaid orders only. Most items are in stock for immediate delivery in factory sealed cartons with full factory warranties.

### —MONITORS—

<b>AMDEK</b>	
300 G (12" green)	135
300 A (12" amber)	145
310 A (IBM PC)	165
600	449
<b>BMC</b>	
12 AU (12" green)	\$79
<b>NEC</b>	
JB-1201 (12" green)	\$155
JB-1205 (12" amber)	155
JC-1212 (12" color)	339
JC-1216 (12" RGB)	439
<b>PANASONIC</b>	
12" Green Monochrome	\$139
12" Amber Monochrome	149
13" RGB	379
<b>PRINCETON</b>	
SR-12	625
Scan Doubler	205
<b>SAKATA</b>	
SG-100 12" Green	\$105
SG-100 12" Color	269
SG-200 12" RGB	539
<b>TAXAN</b>	
KG 12N (12" green)	\$ 99
210 (13" color)	299
400 (13" RGB color)	299
410 (13" RGB color)	379
<b>ZENITH</b>	
Z-122 (12" amber)	\$99
Z-123 (12" green)	89

### —HARD DISKS—

<b>CORVUS</b>	
20Mg. (IBM or Apple)	\$3035
<b>TALLGRASS TECHNOLOGIES</b>	
20MB Hardfile Disk for IBM-PC	2395
<b>Greatakes</b>	
Teamate	Call
Turbo-10 1/2 height	Call

### —DISKETTES—

<b>Maxell</b>	
5 1/4" MD1	\$19.95
5 1/4" MD2	24.95
<b>3M/Scotch</b>	
5 1/4" SSDD	\$18.95
5 1/4" DSDD	22.95
<b>Educator</b>	
Lifetime Warranty	
5 1/4" SSDD	\$14.95
5 1/4" DSDD	16.95
Flip 'n' File/holds 50 Disks	17.95

### —BOARDS—

<b>IBM PC BOARDS</b>	
AST Sixpak plus 64k	299
AST Megaplus 256k	569
Microsoft 256k RAM Board	299
Plantronics Color + Board	399
Quadram New Quadboard	Call
Quadram Quadlink Board	Call
Tecmar 1st MATE Board	229
Tecmar Graphics Master Board	569
PC Peacock Graphics Board	299
64k Chip Kit	2895

### —SYSTEMS—

<b>ALTOS</b>	
	Call
<b>COLUMBIA</b>	
VP Portable 256k	\$1869
MPC 1600-1	Call
MPC 1600-4	Call
<b>CROMEMCO</b>	
	Call
<b>IBM</b>	
	Call

### SOFTWARE

*Discount Prices on  
Most Popular  
Manufacturers!*

<b>MORROW</b>	
NEW Pivot	Call
2 drives, 256K, Modem, LCD	
MD-3	\$1927
2 drives, LQ Printer, MDT-70 Terminal	
<b>NEC</b>	
PC-8201 Portable	Call
PC-8800 Small Business System	1669
PC-8800 16-Bit System	1999
PC-8800 System w/8-in. Drives	2299
<b>NORTHSTAR</b>	
Advantage	Call
<b>SANYO</b>	
MBC 550-2	\$949
MBC 555-1	999
MBC 555-2	1139
<b>APPLE</b>	
Apple II-C w/1 drive, 228K\$1035	
<b>TELEVIDEO</b>	
Tele-PC	Call
Tele-XT	Call
TPC-II Portable	Call
<b>ZENITH</b>	
151-22 w/2 Drives	\$2239
151-52 w/Hard Disk	3599
161-52 Portable	2339

### —TERMINALS—

<b>ESPRIT SYSTEMS</b>	
Esprit	\$475
Esprit III (Detachable Keyboard)	615
<b>New!</b>	
<b>Televideo Personal Terminal</b>	
Personal Terminal	\$399
Personal Terminal w/300 band modem	529
Personal Terminal w/1200 band modem	849
<b>TELEVIDEO</b>	
910	\$439
914	579
924	695
925	699
950	865
970/50	949
<b>QUME</b>	
102 GR. or Amb.	\$429
108 Gr. or Amb.	509
<b>WYSE</b>	
50	529
300 Color	915
<b>ZENITH</b>	
Z-29	\$629
ZT-10	Call
ZT-11	Call

### —MODEMS—

<b>HAYES</b>	
Smartmodem 300	\$215
Smartmodem 1200	479
Smartmodem 1200B	429
Micromodem II-E	249
<b>NOVATION</b>	
D-Cat	\$149
J-Cat	109
Apple Cat II	249
103 Smart Cat	179
Smart Cat+	339
103/212 Smart Cat	409
212 Auto Cat	549
Access 1-2-3	399
<b>SIGNALMAN</b>	
Mk XII	279
Volksmodem	69
Mk VII	129
Mk IL	95
<b>U.S. ROBOTICS</b>	
300 Baud Password	\$149
1200 Baud Password	259
PC 1200 Baud Modem	329
S 100 1200 Baud Modem	329

N.Y. residents, add appropriate sales tax. We accept VISA and Master Card. Personal and company checks, allow 2 weeks to clear. C.O.D.'s require a 25% deposit. All prices and offers may be withdrawn without notice.

restrict your right to copy the software you've purchased. I\*U\*CO is designed to be what every collective organization is: a means to protect the special interests of its members.

And, in this case, the members are the victims...the people who own and use personal computers. The people who, until now, have been powerless.

**First of all,  
I\*U\*CO  
means low prices.**

Software and peripheral manufacturers used to be pretty good about sharing information.

Today, they're not.

In the last few weeks, I personally have learned: a) my Macintosh 512K Upgrade is defective and won't work with MacPaint under certain circumstances; b) the ROMS in my Anadex printer have been upgraded; c) the ROMS in my IOMEGA Bernoulli box have been upgraded; d) MicroPro eliminated the copy protection on my version of Wordstar 2000 Plus; e) MicroPro had a bug in InfoStar for more than 18 months...and didn't tell anyone.

International Union Of Computer Owners, Inc.  
Suite 4806  
30 East Huron Street  
Chicago, Illinois 60611

YES, I'm tired of being ripped off. Enclosed is \$1.00. Please send me the information and enrollment package for I\*U\*CO, the International Union of Computer Owners.

I understand that I am under no obligation to enroll.  
PLEASE PRINT ALL INFORMATION



# OK-WRITER™.M.

## LETTER QUALITY



Enhancement for  
Okidata ML82A/83A  
Dot Matrix Printers

- Easy to install
- Plug-in module
- Letter Quality: 30 cps
- Draft Quality: 120 cps
- 10, 12, 17 cpi

- Full dot addressable graphics
- Front panel access to all features
- Proportional spacing, bold, double width, underlining, self-test, etc.
- Serial and parallel interfaces retained
- HELP mode, Diagnostic HEX dump
- And many other features

# The Statistician

CPM IBM-PC  
TRS-DOS XENIX

- Multiple Regression
- Stepwise Ridge
- All Subsets
- Backward Elimination
- Time Series Analysis
- Descriptive Statistics
- Transformations
- Survey Research
- Nonparametrics
- XY Plots
- ANOVA
- Random Samples
- Data Base
- Search & sort
- Hypothesis tests

Please call **TOLL FREE**  
**1-800-334-0854 (Ext. 814)**

for more information

# Maxell Floppy Disks

The Mini-Disks  
with maximum quality.



Dealer inquiries  
invited. C.O.D.'s  
accepted. Call  
**FREE (800) 235-4137.**

# DUST COVERS

For Personal Computers and Small  
Business Systems, Peripherals, Game  
Units - Protective, Long-Lasting Vinyl  
Resists Both Dust and Liquids

## - CHOICE OF COLORS -

- |           |                   |
|-----------|-------------------|
| Amdek     | Franklin Ace      |
| Apple     | IBM               |
| Atari     | Kaypro            |
| BMC       | Okidata           |
| Columbia  | Rana Systems      |
| Commodore | Star Micronics    |
| Corona    | Televideo         |
| Eagle     | Texas Instruments |
| Epson     | PLUS OTHERS       |

GROUP/VOLUME DISCOUNTS AVAILABLE

FOR **FREE BROCHURE** WRITE:

ENCHANTED FOREST  
P.O. Box 5261, Newport Beach, CA 92662  
(118 Onyx)

Dealer Inquiries Invited

# DATA ACQUISITION TO GO INTERFACE FOR ANY COMPUTER



Connects via RS-232. Built-in BASIC.  
Stand alone capability. Expandable.  
Battery Option. Basic system: 16 ch.  
12 bit A/D, 2 ch. D/A, 32 bit Digital I/O.  
Expansion boards available. Direct  
Bus units for many computers.

SPECIALISTS IN PORTABLE APPLICATIONS  
**(201) 299-1615**

P.O. Box 246, Morris Plains, NJ 07950

## ELEXOR

# DATA ACQUISITION and control for ANY computer



The Model 1232 communicates via RS-232,  
and has 8 analog inputs ( $\pm 4$  VDC; 12 bits),  
8 digital inputs and outputs, and a 2000  
point buffer. Suitable for field data logging  
or lab use, the 1232 costs only **\$690**. The  
8-bit system (0-5 VDC) is **\$490**. Detailed  
manual, **\$6**. Phone our applications  
engineer at **617-899-8629** or write:

★ ★ **STARBUCK** ★ ★  
DATA COMPANY

225 Crescent St., Waltham, MA 02154

Inquiry 141

Inquiry 140

Inquiry 366

# BLUE BOOK

Prices shown for thousands  
of computers, software, and  
peripherals.

Each listing includes sug-  
gested list, avg. retail, whole-  
sale, and used prices for all the  
geographical regions of the  
United States.

Send \$12.95 + \$.50 postage to:

**NCDA**  
National Computer Dealers Association  
5420 Hwy. 6 North  
Houston, Texas 77084

Inquiry 74

# Verbatim flexible disks

Call Free **(800) 235-4137** for  
prices and information. Dealer  
inquiries invited. C.O.D. and  
charge cards accepted.

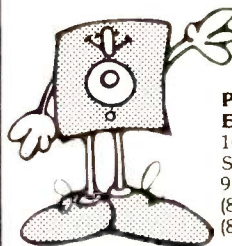

VISA

**PACIFIC  
EXCHANGES**  
100 Foothill Blvd.  
San Luis Obispo, CA  
93401. In Cal. call  
(800) 592-5935 or  
(805) 543-1037.

Inquiry 296

# BIG DISCOUNTS ON LITTLE BOARDS™ & ACCESSORIES

- **AMPRO LITTLE BOARD™**—64K, Z80a CPU, CTC, DART, 1 parallel port, 5 1/4 controller supports four 48tpi and/or 96tpi drives w/CP/M 2.2 and ZCPR3 (A & T) **\$329**
- **SYSTEM SUPPORT PKG**—Manuals, source code schematics, connectors & cables **\$99**
- **SCSI PLUS**—DMA Hard disk interface **\$99**
- **TEAC 55B DSDD** 48tpi 1/2 ht drive **\$159**
- **TEAC 55F DSDD** 96tpi 1/2 ht drive **\$189**
- **INTEGRAND** Custom two drive cabinet with 5 amp power supply & power cables **\$179**
- **TERM-MATE**—Cabinet for 2 1/2 ht + LITTLE BOARD w/all cables & supply **\$229**
- **AMPRO SERIES 100** complete systems **SCALL**

VISA & MASTER CHARGE Personal Checks  
Please allow 2 weeks. Shipped via UPS  
Prices F.O.B. Prairie View, IL  
For additional information write or call:  
DISKS PLUS • 15945 West Pope Blvd. • Prairie View, IL  
60669 • (312) 537-7888

**DISKS PLUS**  
DIVISION OF SOLARONICS INC.

Inquiry 121

# maxell DISKS

LIFETIME WARRANTY

Think you're getting the best price  
on Maxell Diskettes?  
You're right . . . **BUT ONLY IF . . .**  
You're buying from  
**NORTH HILLS CORP.**

We will beat any nationally adver-  
tised price\* or give you a 15 disk  
library case FREE!

Call us last—**TOLL FREE**—for our  
best shot every time.

**1-800-328-3472**

Formatted and hard sector'd disks in  
stock.

Dealer inquiries invited. C.O.D.'s and charge cards

# PRINTER RIBBONS

	PRICE	PER RIBBON	PER DOZEN
ANADIX 9500	10.50	109.80	
APPLE DMP	5.50	58.80	
BROTHER HR-15/25 MS	5.95	68.40	
C. ITOH PROWRITER	5.50	58.80	
COMMODORE MPS-801	8.00	90.00	
EPSON MX-FX 70/80	5.00	48.00	
EPSON MX-FX 100	6.95	75.00	
EPSON LQ-1500	9.75	111.00	
GEMINI 10-10X-15-15X	2.50	23.40	
IBM/IDS 4-COLOR	15.75	180.00	
IDS MICROPRISM-480	5.75	58.80	
NEC - 3500 M/S Non Flip	6.25	69.00	
NEC - 3500 NYLON	9.00	96.00	
NEC - 8023A	5.50	58.80	
OKIDATA 80/82/83/92	2.50	23.40	
RADIO SHACK DMP-2100	7.50	87.00	
RADIO SHACK LP VI & VIII	5.75	58.80	
RITEMAN	8.50	96.00	

# C SOFTWARE DEVELOPMENT PCDOS/MSDOS

- **FULL C COMPILER PER K&R**
- Inline 8087 or Assembler Floating Point
- Full 1 MB Addressing for Code or Data
- Transcendental Functions
- **MSDOS 1.1/2.0 LIBRARY SUPPORT**
- Program Chaining using Exec
- Environment Available to Main
- **c-window™ C SOURCE CODE DEBUGGER**







**NEW**

## Monitor Mover Gives Back the Desk



**\$159.95**

- Models to fit most CRT's
- Rotates 360° on base
- Adjustable height
- Support tray swivels and tilts
- Holds up to 50 lbs
- Clamp, screw and wall mountings

**Lintek**

P.O. Box 8056  
Grand Rapids, MI 49508  
(616) 241-4040

Inquiry 236

## AFFORDABLE M-68000 COMPUTER SYSTEM



**M68KCPU** 6.10 MHz CPU, 20K static RAM, 16K EPROM, on board monitor, two RS-232 serial ports, 16-bit parallel port, 5 timer/counters expansion bus.

**M68KKE** Complete Kit ..... **\$99.95**  
128-512K static RAM, floppy disk controller & hard disk interface Bare board..... **\$99.95**  
Complete Kit (128K)..... **\$725.00**

**M68KAS** M68000 Macro Cross Assembler for CP/M80, IBM PC, TRS-80 and Apple II computers ..... **\$249.00**  
UPS shipping & handling ..... **\$ 4.00**  
COD orders add ..... **\$ 3.00**  
Foreign orders add ..... **\$20.00**  
California residents add 6.5% tax

**EMS** Educational Microcomputer (714) 854-8545  
Systems P.O. Box 16115 • Irvine, CA 92713

Inquiry 136

## \$99 SINGLE BOARD COMPUTER / CONTROLLER



### MODEL MCG-85 FEATURES

8085A CPU	Automatic Baud Rate
2K System Monitor ROM	5 Interrupts
256 Bytes of RAM	14 Bit Counter/Timer
RS232 Port	Onboard Prototyping
Parallel & Serial I/O	6.144 MHz Crystal
* Two 8 Bit Prog Ports	Onboard Expansion
* One 6 Bit Prog Port	* 4K ROM &/or
4 1/2 x 6 1/2 PCB	* 4K RAM or CMOS RAM

**STOCK. \$99 KIT. \$135 ASSEMBLED & TESTED.**  
A/D, Parallel I/O, Memory & Mother Cards Avail.  
STD Product Line also available.  
Visa, M.C., Amex & COD. Add \$5.00 Shipping.

**CUSTOM DESIGNS & DEVELOPMENT**  
**OUR SPECIALTY**  
**SYNALTA SYSTEMS**  
31-14 Broadway  
Astoria, New York 11106  
(718) 728-6700

Inquiry 375

# Osborne

As available only! Very limited quantity.

Important: Always call to check availability before ordering.	To fix yourself, or for parts. Complete, but known not working.	Guaranteed for 30 days. May be new or refurb., depending on avail. Exch./Outright Repair	
Main Board OS-1	\$49	\$79	\$159
Main Board Exec.	\$159	\$139	\$299
Exec. Memory Card	—	\$39	\$89
Double Density Kit **	—	—	\$79
5" CRT (Grn/White)	\$9.95	\$19	\$29
7" CRT (Amber)	\$19	\$49	\$99
15" CRT, no case	—	—	\$85
Drive Analog Card	\$9.95	\$29	\$59
Drive Mechanism	\$19	\$25	\$59
Power Supply	\$4.95	\$24	\$29
Keyboard (No enclos.)	\$19	—	\$99

\*\* Includes board, cable, documentation

Shipping charged on all orders

Computer Parts Mart 415-493-5930  
3200 Park Blvd \* Palo Alto \* CA 94306

Inquiry 87

## YCENTECH PREMIUM COLOR DISKETTES

LOWEST PRICE EVER

**TIMELESS WARRANTY**

SSDD **\$165** ea. 5-1/4" QTY. 20

DSDD **\$215** ea.

~~\$230~~ → ~~\$290~~ ← 96 TPI

Discounts Starting At Quantity 50 & Above

DEFINITELY COLOR-CODED DISKETTES ARE THE MOST EFFECTIVE METHOD FOR ORGANIZING YOUR DISKETTE FILES. Available in Blue, Blue, Green, Yellow, Orange and many other colors. 100% error-free and backed by TIMELESS WARRANTY. Factory fresh and boxed in 10's with Tyvek sleeves, reinforced hubs, write-protect tabs and labels.

SHIPPING: Add \$3.00 per 100 diskettes or fraction thereof. Same day dispatch. VISA and Mastercard accepted. COD orders only add \$3.00 handling charges. Utah residents add 5 1/2% sales tax.

WE WILL BETTER ANY PRICE ON THE SAME PRODUCT AND QUANTITIES ADVERTISED NATIONALLY

**TOLL FREE ORDER LINE ONLY:**  
1-800-233-2477  
INFORMATION AND INQUIRIES:  
1-801-942-6717  
HOURS: 9AM-6PM, M-F (MT. STATE TIME)

**Computer Affairs, Inc.** 2028 E. FT. UNION BLVD. #105  
SALT LAKE CITY, UTAH 84121  
CALL 1-800-AFFAIRS

Inquiry 79

## Microprocessor Software Development on VAX or PDP-11.



You can develop software for Z80, 8080, 8085, NCS800, and 8086 using native mode compilers and assemblers.

Use low-cost cross tools for other microprocessors. Interface in-circuit emulators perfectly. You can run Intel development tools under ISIS or UDI.

Our plug-in processor cards let you run CP/M-80, CP/M-86, or MS-DOS from any terminal on your VAX or PDP-11 system.

Prices start at just \$1295. Ask for our FREE catalog of 350 development and cross development tools.

**Decmaton** 3375 Scott Blvd., Suite 236  
Santa Clara, CA 95054  
(408) 980-1678

Registered Trademarks: VAX, PDP-Digital Equipment Corporation, CP/M-80, 86 Digital Research, MS-DOS-Microsoft Corporation, ISIS, UDI Intel

Inquiry 113

## 5 1/4" FLOPPY MOTORS

Now Buehler OEM replacement spindle motors for all major 5 1/4-inch, full-height floppy disk drives are available for fast delivery. Built to exact OEM size, performance and quality standards. Pulleys included.

**For details and prices, contact:**

Buehler Services, Inc.  
P.O. Box A, Hwy 70-E  
Kinston, NC 28501  
Phone: 919/552-4300



Inquiry 52

## dy Jan Dysan CORPORATION

### SPECIAL DISKETTE OFFER

The Dysan quality difference is yours to try with advanced production techniques that assure every diskette to be 100% error-free.

**PLUS!** If you call, write, or utilize reader service in response to this ad—we'll send you our full-range catalog of computer supplies with Special Offers good for further savings on Dysan diskettes and many other quality products.

**LYBEN COMPUTER SYSTEMS**  
1250-E Rankin Dr., Troy, MI 48063  
Phone: (313) 589-3440

**Simply #1 in Service & Reliability**

**DISCOVER THE DYSAN DIFFERENCE**

Inquiry 242

## 6800 Family Cross-Software

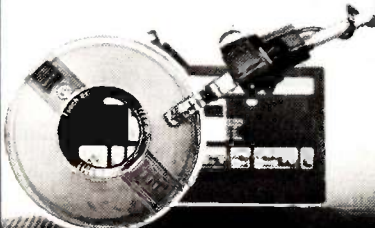

6800/01/05/09 microprocessor software development tools for PDP-11, VAX, IBM or other mainframes: Cross-Assemblers, High-level Language PL/W Compilers, Linker, and Simulators.

**WINTERK** Wintek Corp.  
1801 South Street  
Lafayette, IN 47904  
317-742-8428

Inquiry 403





# FORTRON CORPORATION

3797 YALE WAY, FREMONT, CA 94538

Power Supply Professional

INFORMATION & CALIF. RES. [415] 490-8171

ORDER TOLL FREE: [800] 821-9771

FC 135-40 Features:

- Full Replacement to your regular IBM® PC 65 W. Power Supply
- 4 Disk Drives Connectors
- Built-in High Air Flow High Quality Cooling Fan
- UL File #E82453
- Schematics included
- One year Warranty
- +5V/15A, +12V/4.2-8.5A (peak)
- -12V/1A, -5V/1A. (max. outputs)
- 110-230 VAC Convertible

Quality That You Can Trust

## 140 W.(max) Power Switcher

#FC 135-40



only

**175.00**

[Assembled & Fully Tested in USA]

IDEAL FOR:

- Upgrade IBM® PC
- OEM Manufacturer
- Do it yourself an IBM® PCXT Compatible

Please do not confuse this high quality product with the cheap imported units sold by others because of same outlook.

**Dealers/OEMs are Invited**

For "Build Your Own Computer" and OEM's Convenience, we also carry:

### FC 427 Keyboard

- For IBM® PC or its compatible products
- 20 Million Time Life Cycle
- Light on Num and Caps Lock Keys

**109.00**



### FC 630A-2 Cabinet

- IBM identical
- Use FORTRON FC 135-40 power supply
- 7 & 8 slots rear panels, good for 0.75" or 1" apart slot connectors.

**99.00**



### HSC 130-40 130 Watt Switching Power Supply

- Good For Faraday, DTC Mega-board, Colby Computer and Other Compatible Level CPU boards
- Backside On-Off Switch
- Use Cabinet FC-630
- 110-230 VAC Convertible

**169.00**



### FC-330 Hard Disk Controller

- Up to 2 Hard Disk Drives
- Fully Buffered I/O Bus
- Built-in ECC
- Accepts 5 to 20 MB Hard Disk

**239.00**



### FC-630 Cabinet

- On-off switch to be on back side
- Use FORTRON HSC-130-40 power supply
- Good for Faraday and other compatible level CPU boards.

**99.00**



### Monochrome/Graphic/Printer Card CT-6040

- 80 x 25 Text Mode (Default)
- 720 x 348 Graphic Mode
- Can Run Lotus 1-2-3
- 64K Graphic Display Memory
- 18 KHz Monitor and Printer Interface

**229.00**



### FC-230 Floppy Disk Controller

- Drives 4 x 5 1/4" FDD
- IBM fully compatible

**99.00**



### FC-530 Monochrome Card

- 8 x 25 Screen
- 9 x 14 Character Box
- 7 x 9 Character
- TTL Level of output

**159.00**



### FC-730 Multifunction Card, Expandable to 384K

- From 64 to 384K
- 1 RS-232C, 1 Centronics Printer Ports

**199.00**  
(64K on Card)



### FC-830 512K RAM Card

- From 64K to 512K
- Boundary and Total Memory

**169.00**  
(64K on Board)



### Color/Graphic/Printer Card CT-6020

- RGB Color Port and Parallel Port For Printer
- Light Pen Interface
- Graphic Mode:  
320 Dots x 200 Lines Color  
640 Dots x 200 Lines B/W
- Text Mode:  
40 Columns x 25 Rows Color / B/W  
80 Columns x 25 Rows Color / B/W

**199.00**



### FC-930 RS232/Parallel Printer Port Card

Fully IBM Compatible  
**99.00**



### FC-940 RS232C/Clock Calendar Card

- One RS-232C Port, One Clock Calendar, Battery Back-up

**99.00**



**64K DRAM**  
**25.00/9 pcs.**  
**2764 EPROM**  
**5.25/pcs.**

8237A-5	<b>12.50</b>
8284A	<b>3.90</b>
8284C	<b>1.50</b>
MC1489	<b>0.29</b>
74LS245	<b>0.65</b>

**Hard Disk Drives 625.00**  
(with cable & controller) (10 MB)  
Half Height, Top Brands, 10-32 MB Available

**Check with us for PC/AT Power Supply**

#### SALES TERMS

1. Shipping & Handling charge \$6.00 minimum. Check with us for actual charges
2. CA add 6.5% tax
3. Restocking charge 15%
4. RMA # is required for all return merchandise
5. Prices subject to change without notice

IBM PC/XT ADD-ON CARDS

IBM PC/XT ADD-ON CARDS



# A Spooler that will Spoil You

Addmaster Paper Tape Handler with Big New 7 1/2" Reels



Optional serial interfaces for RS232C or TTY or parallel interface/TTL. X-on/X-off capability, bi-directional reading and slew, reads 150 CPS, rewinds 300 CPS. Stops on character, contains power supply and Addmaster Model 601 paper tape reader. Sensibly priced. **Addmaster Corporation**, 416 Junipero Serra Drive, San Gabriel, CA 91776. (213) 285-1121.

Inquiry 10

## CHIPS 'n DIPS

QUANTITY ONE PRICES

8087-3	\$145.00
8088	29.00
256K DRAM	12.00
64K DRAM 150ns	2.20
64K DRAM 200ns	2.18
128K DRAM	
Mostek 150ns	18.00
5 1/4" Diskettes	1.75

FREE UPS SHIPPING

All parts in stock, first quality.  
No seconds or surplus.  
Same day shipping!

**CHIPS 'n DIPS**  
P.O. Box 2517 • The Mall  
Duxbury, MA 02331

**617-934-2414**

Inquiry 65

## LOW COST UNIVERSAL (E)PROM PROGRAMMER



- SUPPORTS: (EPROMS) 2516 THRU 64, 2716 THRU 512, 27C16 THRU 128, 80732 THRU 66 (EEPROMS) 52R13 THRU 33, 2816A THRU 64A (MICROS) 8741 THRU 43H
- NO PERSONALITY MODULES, ONBOARD POWER SUPPLY
- RS232C INTERFACE, NON-XOFF, RTS, CTS, DTR
- ACCEPTS KEYBOARD ENTRY WITH LINE EDITING
- ACCEPTS ASCII, INTEL, AND MOTOROLA POINTS
- USER FRIENDLY MONITOR FOR I/O DEBUGGING
- FAST PROGRAMMING SUPPORTED: 2764 UNDER 3 MIN.
- LOW/HIGH BYTE PROGRAMMING FOR 16 BIT DATA PATH
- BYTE, BLOCK, OR CHIP ERASE (EEPROMS ONLY)
- LIST IN INTEL OR MOTOROLA HEX POINTAT
- VERIFY PROGRAM AND VERIFY BLANK COMMANDS

1409 01: 4K FIRMWARE, PCB, XFORMER, DOC	\$90.00
1409 02: 1409-01 + FULL SET OF PARTS	\$200.00
1409 03: ASSEMBLED AND TESTED UNIT	\$300.00
1409 11: 8K FIRMWARE, PCB, XFORMER, DOC	\$125.00
1409 12: 1409 11 + FULL SET OF PARTS	\$250.00
1409 13: ASSEMBLED AND TESTED UNIT	\$350.00
COMMUNICATION DRIVERS FOR MOST PCs	\$35.00

**MICROSYSTEMS**  
6322 MOLAVE DR., SAN JOSE, CA 95120  
Tel. (408)997-7685. TWX 4996363

Inquiry 68

## I.B.M. Adapter

Floppy Disk Control  
Card \$89.00  
Color Graphic Card \$145.00  
416K RAM \$3.75 ea.  
\$34.50 9 pcs.  
Compatible  
Motherboard Call

## APPLE INTERFACE CARD

ITL & CMOS Tester  
Card Call  
Z-80 Card \$40.00  
80 Column Card \$50.00

PROM 8200 PROGRAMMER (FAST UNIVERSAL TYPE EPROM & PROM PROGRAMMER) FOR EPROM 2716-27256; 2516-25256 (NO ADAPTER NEEDED) FOR PROM 63xx, 74Sxx, 145xx, 185xx, 245xx, 285xx, 825xx, 875xx, INCLUDE RS232 INTERFACE

Color Printer (180)pcs, 7 colors) \$695.00  
Color Printer (4 colors) \$495.00

ALL PHONES  
CALL NOW (312) 280-7610

**DIST. WANTED**

## HOFFMAN INT'L

600 N McClurg CT. STE. 309A  
Chicago, Illinois 60611

Inquiry 187

## MEMOREX

**SPECIAL OFFER  
ON DATA  
RELIABLE DISCS**



Memorex seals its floppy discs with a process it developed, called Solid-Seam Bonding. This seals shut every inch of every seam of every Memorex floppy disc.

**PLUS!** If you call, write, or utilize reader service in response to this ad—we'll send you our full-range catalog of computer supplies with Special Offers good for further savings on Memorex diskettes and many other quality products.

## LYBEN COMPUTER SYSTEMS

1250-E Rankin Dr., Troy, MI 48063  
Phone: (313) 589-3440

**Simply #1 In Service & Reliability**

**CERTIFIED 100% ERROR-FREE**

Inquiry 243

## PAL WRITER CARD



\$299

This PAL WRITER CARD programs all MMI, TI, NS 20 and 24 Pin PALS. This PAL WRITER CARD is a plug-in Card for APPLE II, IIe and Compatible computers without attach power supply, can write, read, copy, protect ...etc. ALSO supply PALASM compiler.  
\* WE also sell 17MHZ, 8 channel LOGIC ANALYZER CARD.

TELEX: 27611 PLOGIC  
ATTN—"CLOCK"



CABLE: "CLOCK" TAIPEI  
P.O. BOX: 93-247 TAIPEI R.O.C.  
CLOCK COMPUTER CORP.

Inquiry 68

**MARYMAC INDUSTRIES INC.**

800-231-3680

## Radio Shack TRS-80's Epson Printers

People you Trust to give you the very best!



• Lowest Discount Prices

• Reliable Service

• Quality Products

"Worlds largest volume TRS-80 dealer."

22511 Katy Fwy., Katy (Houston) Texas 77450  
(713) 392-0747 Telex 774132

Inquiry 250

## EPROM PROGRAMMER



APPROTEK 1000 ONLY

**\$249.95**

COMPLETE WITH PERSONALITY MODULE

117 AC POWER-RS232  
-6 BAUD RATES - HANDSHAKE TO HOST  
**ALLOWS READ, WRITE, VERIFY & COPY**

Comes complete with CPM & BASIC Driver Program Listings for most small micros

### Full 1 Year Warranty

Programs the following: 5 Volt 24 or 28 pin devices; 27xx series through 27256, 25xx series, 68766 plus others  
Specify Personality Module desired with order  
Additional Personality Modules only \$15.00 ea

TO ORDER: CALL OR WRITE

### APROPOS TECHNOLOGY

1071-A AVENIDA ACASO Add  
CAMARILLO, CA 93010 \$4.00 Shipping-USA  
(805) 482-3604 VISA or MC Add 3%

Inquiry 30



**Sure  
it's insured?**

SAFWARE Insurance provides full replacement of hardware, media and purchased software. As little as \$35/yr covers:

- Fire • Theft • Power Surges
- Earthquake • Water Damage • Auto Accident

For information or immediate coverage call:

**1-800-848-3469**

In Ohio call (614) 262-0559



SAFWARE, THE INSURANCE AGENCY INC.

Inquiry 341

**KRUEGER**  
Technology, Inc.  
offers you an  
attractive  
alternative  
on the purchase  
of guaranteed ICs.

# COMPARE OUR PRICES! 100% GUARANTEED ICs

EXTRA  
SPECIAL  
FEATURE



**TMS 9900**  
**3.00**

**MICROPROCESSOR**  
For your TI99A  
Computer. This item is  
no longer manufactured

## GROUP SPECIALS

### 74 Series

74XX	.25
741XX	.35
742XX	.49
743XX	.49

### 74LS Series

74LSXX	.25
74LS1XX	.35
74LS2XX	.49
74LS3XX	.49

### 74S Series

74SXX	.35
74S1XX	.45
74S2XX	.59
74S3XX	.59

## OUR POLICY

Delivery: Orders normally shipped within 2 business days. Add \$3 for UPS ground-5# & under. Add \$4 for UPS blue (air), 2# & under; for each additional air pound add \$1. Arizona residents add 6% sales tax.

Payment: Visa, MC, cashiers check, certified check, money order, personal check accepted. (Allow 10 days for personal checks to clear.) No surcharge on credit card orders. CODs welcome with cash, certified check, cashiers check or money order. Add \$3 COD handling charge.

Pricing: Minimum order \$20. 30% discount on orders over \$500. Prices subject to change without notice. All items limited to stock on hand.

## COMPARE 2764 200NS 5.93

### EPROMS

1702	2K	2.63
2708	8K	2.37
68708	8K	7.50
2716 300-450NS	16K	2.63
2716 500-650NS	16K	1.88
2532, 2732 200NS	32K	4.20
2532, 2732 250NS	32K	3.75
2753	64K	3.20
68766 (24 PIN)	64K	11.86
2564, 2764 300NS	64K	5.93
27128 250NS	128K	11.95
27128 300NS	128K	10.95
27128 450NS	128K	9.95

## COMPARE 4116 200NS .59

### DYNAMIC RAMS

4164 150NS	64K	919.95
4164 150NS	64K	2.75
TMS4416	64K	2.75
4164 250NS	64K	1.75
2620	64K	2.75
4332	32K	3.00
2118	16K	1.50
4116 150NS	16K	.89
4116 200NS	16K	.59
4116 250NS	16K	.39
4027	4K	.45

## COMPARE 6116 250NS 2.93

### STATIC RAMS

10415	1Kx1	6.26
2115	1Kx1	1.13
2125	1Kx1	1.50
93415	1Kx1	3.38
93425	1Kx1	3.38
2510	1Kx1	3.38
2511	1Kx1	3.38
2148	1Kx4	3.92
2149	1Kx4	3.92
10474	1Kx4	3.00
2114 200NS	1Kx4	.70
2114 450NS	1Kx4	.50
4801 70NS	1Kx8	3.38
4118 250NS	1Kx8	2.93
6116 200NS	2Kx8	3.68
6116 250NS	2Kx8	2.93
10470	4Kx1	10.44
2141	4Kx1	1.05
2147	4Kx1	3.38
TMS4044 200NS	4Kx1	1.05
TMS4044 300NS	4Kx1	.90
1420	4Kx4	4.50
2168	4Kx4	4.50
2167	16Kx1	4.50

\*"L" Series slightly higher.

## COMPARE 6810 .75

### 6500/6800 MICROPROCESSORS

6502	1.50
6503	1.50
6504	2.75
6512	1.25
6522	2.75
6532	3.75
6545	8.00
6800	1.75
6802	3.25
6803	7.50
6809	5.00
6810	.75
6820	1.50
6821	1.25
6844	10.50
6850	1.50
6852	2.25
6860	3.25
6875	2.75

## COMPARE 8155 2.85

### 8000 Series

8031	14.00	8243	5.00
8035	3.75	8251	3.25
8039	3.75	8253	3.50
8080A	2.25	8253-5	4.00
8085	3.75	8255	3.25
8085A2	7.50	8255-5	3.75
8086	12.00	8257	3.50
8088	11.25	8257-5	4.00
8155	2.85	8259	3.50
8741	18.00	8259-5	4.00
8748	18.00	8272	16.00
8202	13.50	8274	25.00
8205	2.25	8276	17.50
8212	1.00	8279	4.00
8214	2.25	8279-5	5.00
8216	1.00	8284	4.00
8224	1.50	8286	4.50
8226	1.25	8287	4.50
8228	2.25	8288	10.00
8237	6.75	8289	18.00
8237-5	7.50	8292	5.00
8238	3.00		

## COMPARE TMS9904 1.50

### MISCELLANEOUS

TMS9901	1.50	TMS9900	3.00
TMS9904	1.50	9602	1.10
TMS9914	3.00	96L02	2.25
TMS9980	13.25	96LS02	3.75

## COMPARE Z80CPU 1.13

### Z80 Series

2.5 MHZ		4.0 MHZ (Z80 A)	
CPU	1.13	CPU	1.88
CTC	1.13	CTC	1.88
DART	3.00	DART	4.50
DMA	3.00	DMA	4.50
PIO	1.13	PIO	1.88
SIO (Any)	3.00	SIO (Any)	4.50

## COMPARE DAC08 1.14

### DATA ACQUISITION

DAC08	1.14
DAC0800	9.90
DAC0806	1.14
DAC0808	1.44
ADC0809	2.48

## COMPARE D765 11.25

### FLOPPY DISK CONTROLLERS

D765	11.25	8877	11.25
17.91	11.25	8272	18.00
17.93	11.25	2143	5.25
8876	11.25	9216	5.25

## COMPARE CRT 5027 5.00

### CRT CONTROLLERS

CRT5027	5.00
CRT5037	10.00
6845	5.00
46505	5.00

## COMPARE AY5-1013A 2.00

### UARTS

AY5-1013A	2.00	1482	4.50
AY3-1015A	3.00	2350	4.50
TR1402	2.00	2651	4.50
TR1602	2.25	6402	3.50
TR1863	2.25	7201	10.50
TR1472	4.50		

NOTE: This is just a sampling of our 6 million IC Inventory.

# KRUEGER Technology, Inc.

2219 South 48th Street • Tempe, AZ 85282

**800-245-2235**

In Arizona 602-438-1570

HOURS: 8 a.m.-5 p.m.  
(MOUNTAIN TIME)  
Monday Thru Friday





## CONVERSE WITH YOUR COMPUTER

AT LAST! A FULL IMPLEMENTATION of the original ELIZA program is now available to run on your microcomputer!

Created at MIT in 1966, ELIZA has become the world's most celebrated artificial intelligence demonstration program. ELIZA is a non-directive psychotherapist who analyzes each statement as you type it in and then responds with her own comment or question—and her remarks are often amazingly appropriate!

Designed to run on a large mainframe, ELIZA has never before been available to personal computer users except in greatly stripped down versions lacking the sophistication which made the original program so fascinating.

Now, our new microcomputer version possessing the FULL power and range of expression of the original is being offered at the introductory price of only \$25. And if you want to find out how she does it (or teach her to do more), we will include the complete SOURCE PROGRAM for only \$20 additional.

Order your copy of ELIZA today and you'll never again wonder how to respond when you hear someone say "Okay, let's see what this computer of yours can actually do!"

### ELIZA IS AVAILABLE IN THE FOLLOWING FORMATS:

- 5 1/4 inch disk for the 48K Apple II, II Plus, IIe or IIC  
\$25 for Protected Version—\$45 for Applesoft Source Version
- 5 1/4 inch disk for the 64K IBM Personal Computer  
\$25 for Protected Version—\$45 for IBM Disk BASIC Source Version
- 5 1/4 inch disk or tape cassette for the Commodore 64 (specify which)  
\$25 for Protected Version—\$45 for C-64 BASIC Source Version
- Standard 8 inch single density disk for all CP/M based computers  
\$25 for ELIZA.COM—\$45 with Microsoft BASIC-80 Source
- 5 1/4 inch disk for most CP/M based computers (specify computer)  
\$25 for ELIZA.COM—\$45 with Microsoft BASIC-80 Source

Please add \$2.00 shipping and handling to all orders  
(California residents please add 6% sales tax)

### ARTIFICIAL INTELLIGENCE RESEARCH GROUP

921 North La Jolla Avenue, Dept. B  
Los Angeles, CA 90046  
(213) 656-7368 (213) 654-2214  
MC, VISA and checks accepted



Inquiry 31

## BASF FlexyDisks®



### 5 1/4"

Specify soft,  
10 or 16 sector

Minimum Order 20

Single side  
double density

**1.35** ea

Double side  
double density

**1.55** ea

Hard sectors in Library box only .15.

### IMMEDIATE SHIPMENT

Certified Check - Money Order - Personal Check.  
MasterCard and Visa. Add \$3.00 per 100 or part  
to each order for U.P.S. shipping charges.

NJ Residents add 6% sales tax.

**DATA**  
EXCHANGE, INC.

178 Route 206 South, P.O. Box 993  
Department B  
Somerville, N.J. 08876 • (201) 874-5050

Inquiry 105

## THE WORLD'S FASTEST S-100 Z-80 SLAVE PROCESSOR TurboSlave I

- 8 Mhz Z-80H
- 128k Ram with parity
- Data transfers to 1 mbyte/second
- 2 RS-232 Ports 50-38 k baud
- S-100 IEEE 696 compatible
- F I F O communications
- 4k Monitor ram
- On board diagnostics
- Low parts count
- Low power consumption
- No paddle boards
- TurboDOS compatible

• GUARANTEED COMPATIBLE WITH ALL S-100 SYSTEMS RUNNING TURBODOS

**INTRODUCTORY PRICE \$495**

Includes TurboDOS drivers (a \$100 value) and TurboSlave I with 128k ram.



EARTH COMPUTERS

P.O. Box 8067, Fountain Valley, CA 92728  
TELEX: 910 997 6120 EARTH FV

FOR MORE INFORMATION AND QUANTITY DISCOUNTS  
CALL: (714) 964-5784

Registered trademarks: Z-80, Zilog Inc., TurboDOS Software-2000, Inc.  
IBM PC VERSION COMING SOON...

Inquiry 133

## IBM-PC \$1699

256 K 2 DS/DD DRIVES

Other Configurations Available

- EPSON FX-80/100... Best Price  
OKIDATA 92P/93P... Best Price  
BROTHER HR-15 ..... **\$395**  
HR-25 ..... **\$690**  
P.G.S. MAX-12 ..... **\$175**  
HX-12 ..... **\$459**  
TANDON (360 K) ..... **\$155**  
TEAC 55B (360 K) ..... **\$132**

We carry a large selection of  
hardware and software

**CALL US**

**COMPUTERLANE UNLTD. INC.**  
Exporting Div. Telex: 662841 SK COMP

(818) 884-8644 HOURS  
DAILY  
22107 Roscoe Blvd. 10-7  
Canoga Park, Ca 91304  
We Accept C.O.D. - P.O. - L.C.

Inquiry 90

## DEC/TEKTRONIX TERMINAL EMULATION

For The IBM PC, XT, AT, PCjr  
And Compatibles

PC102 precisely emulates four DEC terminals:  
VT102, VT101, VT100, and VT52. PC4010  
includes all PC102 features plus Tektronix 4010  
graphics terminal emulation.

- Complete keyboard/screen emulation including line graphics (132-column support optional)
- Supports ANSI color, local printer, and bidirectional file transfer; exclusive DOS shell key
- Guaranteed compatibility with all DEC applications including EDT, WORD-11, ALL-IN-ONE, DEC-CALC, UNIX vi
- Written in C and assembler to provide a completely memory-resident package that communicates at up to 38.4K baud

Find out why over 3,000 customers prefer our products. Call or write for free information package.

**GENERAL MICRO SYSTEMS**  
6440 Flying Cloud Drive, Suite 205  
Eden Prairie, Minnesota 55344  
(612) 944-0593

Inquiry 163

## PRICE BUSTERS!

wabash  
**DATA TECH**  
DISKETTES

- LIFETIME WARRANTY** SOFT SECTOR ONLY  
**100% ERROR FREE**
- 5 1/4" SSDD Qty 20 **\$109** ea.
  - 5 1/4" SSDD Qty 20 **\$119** ea.
  - 5 1/4" DSDD Qty 20 **\$149** ea.
  - 3 1/2" ss **\$399** ea.
- MAC COMPATIBLE Qty. 10

Shipping \$3.50 any day  
New: Outside Cont'n 48 States  
shipping \$3.50 plus \$1  
per 10 disettes.  
CA residents add sales tax.

**NEW 5 1/4" \$489**  
ea.  
high Density Qty 10  
for IBM PC-AT

FOR IMMEDIATE SHIPMENT. Use VISA or MASTERCARD  
Call Collect: **818/700-0330**

**YORK 10**

9525 Vassar Ave. #81  
Chatsworth, CA 91311

Inquiry 406

## Dysan CORPORATION

Solve your disc problems, buy 100% surface  
tested Dysan diskettes. All orders shipped  
from stock, within 24 hours. Call toll FREE  
(800) 235-4137 for prices and information.  
Visa and Master Card accepted.



**PACIFIC EXCHANGES**  
100 Foothill Blvd.  
San Luis Obispo, CA  
93401 (In Cal call  
(805) 543-1037)

Inquiry 296

## IN LESS THAN 3 MINUTES

Your IBM Model 50, 60, 65, 75, 85, 95  
or WHEELWRITER Typewriter can be  
a computer printer or terminal using  
our interface modules:

Model 5060 RS232 Serial  
Model 5060-CP Centronics Parallel

Both Versions  
can be easily  
installed and  
require NO  
modifica-  
tions to the  
typewriter.  
A 2K buffer is  
standard, 8K optional.

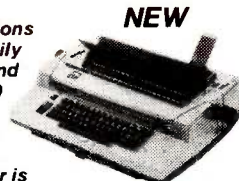

**CMC CALIFORNIA MICRO  
COMPUTER**

9323 Warbler Ave., Fountain Valley, CA 92708  
(714) 964-9301

## PC EXPANSIONS

- Qume 142A ..... \$189
- Teac FD55B ..... \$129
- Tandon TM100-2 ..... \$169
- Tandon TM101-4 ..... \$239
- CDC 9409 ..... \$169
- Maynard Disk Controller ..... \$114
- Sandstar Series ..... \$call
- Internal 10MB HD systems: WS1 ..... \$849
- WS2 ..... \$1020
- MaynStream tape backup ..... \$1229
- Quadboard (64K) ..... \$254
- Quadboard (384K) ..... \$379
- Quadcolor I ..... \$199
- AST SixPakPlus (64K) ..... \$259
- SixPakPlus (384K) ..... \$384
- MegaPlus (64K) ..... \$269
- Advantage ..... \$call
- I/O Plus ..... \$129
- PCnet - starter kit ..... \$809
- HERCULES graphics board ..... \$339
- Color Card with PP ..... \$169
- HAYES Modems: 300 ..... \$199
- Smartmodem 1200 ..... \$469
- Smartmodem 1200B ..... \$399
- Set of 9 chips (64K) ..... \$25
- 256K chips (each) ..... \$12
- 8087 chip ..... \$139
- Verbatim Datalife disks (20) ..... \$49

**VLM Computer Electronics**  
10 Park Place • Morristown, NJ 07960  
(201) 267-3268 Visa, MC, Check or COD

Inquiry 397





Now, the lowest prices ever on

# 3M Scotch® DISKETTES

LIFETIME WARRANTY!

**\$149** ea. 5 1/4" SSDD Qty. 50 **\$199** ea. 5 1/4" DSDD Qty. 50

5 1/4" SSDD-96TPI → \$2.29 ea. 5 1/4" DSDD-96TPI → \$2.85 ea.  
SOFT SECTOR ONLY! MINIMUM ORDER: 20 DISKETTES  
ADD 3% FOR ORDERS UNDER \$50! **FREE!** FLIP 'N FILE 15 w/10 DISKETTES. (Exp. Thru 5/30/85)

These are factory-fresh 3M diskettes packed in boxes of 10 with Tyvek sleeves, reinforced hubs, identification labels and write-protect tabs.

3.5" MICRO-DISKETTES—SS-135 TPI → \$2.89 ea.

LIFETIME WARRANTY ON ALL 3M SCOTCH DISKETTES!

HOURS: 8AM-5PM Central Time, Monday-Friday

WE WILL BEAT ANY NATIONALLY ADVERTISED PRICE ON THE SAME PRODUCTS AND QUANTITIES!

**DISK WORLD!, Inc.**

Suite 4806 • 30 East Huron Street • Chicago, Illinois 60611

**DISK WORLD!**

Authorized Distributor  
Information Processing  
Products



FANTASTIC LOW PRICES ON

# BASF

## QUALIMETRIC DISKETTES!

LIFETIME WARRANTY!

**\$129** ea. 5 1/4" SSDD Qty. 20 **\$149** ea. 5 1/4" DSDD Qty. 20

5 1/4" SSDD-96TPI → \$1.46 ea. 5 1/4" DSDD-96TPI → \$1.75 ea.

PACKED IN CARDBOARD CASES!

BASF QUALIMETRIC DISKETTES have a LIFETIME WARRANTY with Tyvek sleeves, reinforced hubs, user identification labels and write-protect tabs.

SOFT SECTOR ONLY! MINIMUM ORDER: 20 DISKETTES

BASF 3.5" MICRO-FLOPPIES BASF 5 1/4" HIGH DENSITY FOR IBM PC-AT

SSDD-135 TPI → \$2.50 ea. DSDD-HD → \$4.91 ea.

FOR ORDERS ONLY: 1-800-621-6827 (In Illinois: 1-312-944-2788)

INFORMATION & INQUIRIES: 1-312-944-2788

HOURS: 8AM-5PM Central Time, Monday-Friday

WE WILL BEAT ANY NATIONALLY ADVERTISED PRICE ON THE SAME PRODUCTS AND QUANTITIES!

**DISK WORLD!** Authorized Reseller Information Processing Media **BASF**

Incredible value!

# Nashua™ Diskettes

LIFETIME WARRANTY!

**\$105** ea. 5 1/4" SSDD Qty. 50 **\$115** ea. 5 1/4" DSDD Qty. 50

These are poly-bagged diskettes packaged with Tyvek sleeves, reinforced hubs, user identification labels and write-protect tabs. NASHUA Corporation is a half-billion dollar corporation and a recognized leader in magnetic media.

SOFT SECTOR ONLY! Sold in multiples of 50 only!

FOR ORDERS ONLY: 1-800-621-6827 (In Illinois: 1-312-944-2788)

INFORMATION & INQUIRIES: 1-312-944-2788

HOURS: 8AM-5PM Central Time, Monday-Friday

WE WILL BEAT ANY NATIONALLY ADVERTISED PRICE ON THE SAME PRODUCTS AND QUANTITIES!

**DISK WORLD!, Inc.**

Suite 4806 • 30 East Huron Street • Chicago, Illinois 60611

**DISK WORLD!**

Authorized Distributor  
NASHUA MAGNETIC MEDIA

## BETTER MODEMS

AT LOWER PRICES!

...and get 24-hour shipping on your DISK WORLD! orders

1200/300 Baud Avatex Modem **\$189.95** ea. 300 Baud Avatex Modem **\$59.95** ea.

Avatex Modems have everything. They're inexpensive, Hayes-compatible, Auto Dial, Auto Answer and high quality (backed by a one-year warranty).

Best of all, our combination includes a One-Year FREE subscription to MCI MAIL and special communications software for placing TOLL-FREE orders with DISK WORLD!

Orders received via MCI MAIL are shipped within 24-hours (subject to product availability). (Cables are not included.)

FOR ORDERS ONLY: 1-800-621-6827 (In Illinois: 1-312-944-2788)

INFORMATION & INQUIRIES: 1-312-944-2788

HOURS: 8AM-5PM Central Time, Monday-Friday

WE WILL BEAT ANY NATIONALLY ADVERTISED PRICE ON THE SAME PRODUCTS AND QUANTITIES!

**DISK WORLD!, Inc.**

Suite 4806 • 30 East Huron Street • Chicago, Illinois 60611

**DISK WORLD!**

Authorized Distributor  
AVATEX MODEMS

# DISK WORLD!

## Ordering & Shipping Instructions

Shipping: 5 1/4" & 3.5" DISKETTES—Add \$3.00 per each 10 or fewer diskettes. Other Items: Add shipping charges as shown in addition to other shipping charges. Payment: VISA and MASTER-CARD accepted. COD Orders: Add additional \$3.00 Special Handling charge. APD, FPO, AK, HI & PR Orders: Include shipping charges as shown and additional 5% of total order amount to cover PAL and insurance. Taxes: Illinois residents only, add 8% sales tax.

Prices subject to change without notice.

This ad supercedes all other ads.

Not responsible for typographical errors.

MINIMUM TOTAL ORDER: \$35.00

FOR ORDERS ONLY: 1-800-621-6827 (In Illinois: 1-312-944-2788)

INFORMATION & INQUIRIES: 1-312-944-2788

HOURS: 8AM-5PM Central Time Monday-Friday

WE WILL BEAT ANY NATIONALLY ADVERTISED PRICE ON THE SAME PRODUCTS AND QUANTITIES!

**DISK WORLD!, Inc.**

Suite 4806 • 30 East Huron Street • Chicago, Illinois 60611

**DISK WORLD!**

## ATHANA DISKETTES

The great unknown!

**99¢** ea. 5 1/4" SSDD Qty. 50 **\$109** ea. 5 1/4" DSDD Qty. 50

You've used these diskettes hundreds of times... as copy-protected originals on some of the most popular software packages. They're packed in poly-bags of 25 with Tyvek sleeves, reinforced hubs, user identification labels and write-protect tabs.

LIFETIME WARRANTY!

SOFT SECTOR ONLY! Sold in multiples of 50 only.

FOR ORDERS ONLY: 1-800-621-6827 (In Illinois: 1-312-944-2788)

INFORMATION & INQUIRIES: 1-312-944-2788

HOURS: 8AM-5PM Central Time, Monday-Friday

WE WILL BEAT ANY NATIONALLY ADVERTISED PRICE ON THE SAME PRODUCTS AND QUANTITIES!

**DISK WORLD!, Inc.**

Suite 4806 • 30 East Huron Street • Chicago, Illinois 60611

**DISK WORLD!**

Authorized Distributor  
ATHANA MAGNETIC MEDIA

# DISKETTE STORAGE CASES

## AMARAY MEDIA-MATE 50: A REVOLUTION IN DISKETTE STORAGE



Every once in a while, someone takes the simple and makes it elegant! This unit holds 50 5 1/4" diskettes, has grooves for easy stacking, inside nipples to keep diskettes from slipping and several other features. We like it!

**\$10.95** ea. Shpng. + \$2.00

DISKETTE 70 STORAGE: STILL A GREAT BUY.

Dust-free storage for 70 5 1/4" diskettes. Six dividers included. An excellent value.

**\$11.95** + \$3.00 Shpng.



DISK CADDIES

The original flip-up holder for 10 5 1/4" diskettes. Beige or grey only.

**\$1.65** ea. + 20¢ Shpng.

FOR ORDERS ONLY: 1-800-621-6827 (In Illinois: 1-312-944-2788)

INFORMATION & INQUIRIES: 1-312-944-2788

HOURS: 8AM-5PM Central Time, Monday-Friday

WE WILL BEAT ANY NATIONALLY ADVERTISED PRICE ON THE SAME PRODUCTS AND QUANTITIES!

**DISK WORLD!, Inc.**

Suite 4806 • 30 East Huron Street • Chicago, Illinois 60611

**DISK WORLD!**

The value leader in  
Computer supplies  
And accessories.

# PRINTER RIBBONS:

at extraordinary prices!

Brand new ribbons, manufactured to Original Equipment Manufacturer's specifications, in housings. (Not re-inked or spools only.)

LIFETIME WARRANTY!

Epson MX-70/80 ... \$3.58 ea. + 25¢ Shpng.

Epson MX-100 ... \$4.95 ea. + 25¢ Shpng.

Okiata Micro83 ... \$1.48 ea. + 25¢ Shpng.

Okiata Micro84 ... \$3.66 ea. + 25¢ Shpng.

FOR ORDERS ONLY: 1-800-621-6827 (In Illinois: 1-312-944-2788)

INFORMATION & INQUIRIES: 1-312-944-2788

HOURS: 8AM-5PM Central Time, Monday-Friday

WE WILL BEAT ANY NATIONALLY ADVERTISED PRICE ON THE SAME PRODUCTS AND QUANTITIES!

**DISK WORLD!, Inc.**

Suite 4806 • 30 East Huron Street • Chicago, Illinois 60611

**DISK WORLD!**

# Nail down great prices on MEMOREX diskettes!

LIFETIME WARRANTY!

**\$128** ea. 5 1/4" SSDD Qty. 20 **\$170** ea. 5 1/4" DSDD Qty. 20

MEMOREX DISKETTES come with heavy, lintless paper sleeves, reinforced hubs, write-protect tabs and user ID labels.

3.5" MICRO-FLOPPIES SSDD-135TPI \$2.44 ea. SOFT SECTOR ONLY! MINIMUM ORDER 20 DISKETTES \$3.89 ea.

5 1/4" DSDD-HD FOR IBM PC-AT

INFORMATION & INQUIRIES: 1-312-944-2788

HOURS: 8AM-5PM Central Time Monday-Friday

WE WILL BEAT ANY NATIONALLY ADVERTISED PRICE ON THE SAME PRODUCTS AND QUANTITIES!

**DISK WORLD!, Inc.**

Suite 4806 • 30 East Huron Street • Chicago, Illinois 60611

**DISK WORLD!**



**DOUBLE** PLOTTER, COLOR PRINTER, LETTER CASSETTE REORDER, VOICE REORDER, STYLING, SOLG, STYLING

**THE OPTION CAPACITY OF YOUR IBM PERSONAL COMPUTER**

## PC-XTRA

- DIRECT EXTENSION OF IBM PC BUS
- NO SOFTWARE CHANGES
- NO HARDWARE MODIFICATION
- STYLING CONSISTENT WITH IBM

Add all those special options that you've been wanting without worrying about filling your plug-in and back panel space



**DEALER INQUIRIES INVITED.**

**\$549.00\*** F.O.B. SANTA ANA  
\*CALIFORNIA RESIDENTS ADD 6% SALES TAX

**P C HORIZONS, INC.**  
1701 E. Edinger, Ste. A6, Santa Ana, CA 92680  
(714) 953-5396

Inquiry 294

**YOUR MOTHER'S**

AT

*The Byte Shop*

Our New On-Line Computer Product Center

- PLACE YOUR ORDER
- ACCESS DATA-BASES
- BROWSE OUR PRODUCT CATALOG
- SEND ELECTRONIC MAIL

for a password and a user name contact

**MASTERBYTE COMPUTERS OF NEW YORK**  
*Premium Quality Computers and Computer Parts*

SUITE 815 19 WEST 34TH STREET  
NEW YORK, NEW YORK 10001  
(212) 760-0340

a stride micro dealer ©1985

Inquiry 251

**Public Domain Software** and for the **IBM-PC** compats

PC-SIG has one of the most comprehensive collections of public domain and user-supported software for the IBM PC - over 270 disks full. Programs range from full function word processors and filing programs to useful utilities, games and numerous specialized applications. 200 page directory. \$6.95 + \$1.50 postage.

Set of 5 introductory disks (word processing, filing, utilities and games) + Directory \$36. Online bulletin board also available.  
(CA residents add sales tax)  
ISBN 0-915835-02-9



**PC Software Interest Group**  
1125 Stewart Ct., Suite G  
Sunnyvale, CA 94086 (408) 730-9291

Inquiry 299

**Turbo + PC Tools = Programs**  
*Tools for Turbo Pascal™ on the IBM™ PC*

**Window Management = menus, help files...**

- Unlimited windows
- Window overlay & recall
- Cursor save & jump
- Access all colors & chars
- Window Compiler/Librarian manages window files

**Graphics Drawing = HiRes plotting power!**

- Ellipses, polygons
- Region fill and clear & more

**String Formula Evaluator = easy calculation**

- 22 functions with nesting and implicit multiplication
- Won't bomb on overflow or division by zero

**System Check and Control = max flexibility!**

- Time & date access
- Get disk types & room
- Get & set default
- I/O information drive

All this for only **\$39.95\***... Incredible!  
You get 321K of source code on a double-sided disk and a 35 page manual. For single-sided drives add \$2. Works with DOS 2.0, Turbo 2.0.  
\*Please include \$2 for postage and handling (\$4 if outside of USA). Californians add 6%.

**Paragon Courseware**  
4954 Sun Valley Road  
Del Mar, CA 92014  
(619) 481-1477

Turbo Pascal is a trademark of Borland International  
IBM is a trademark of the IBM Corporation

Inquiry 297

**Erases Most Eproms in 3 Minutes**



**ONLY \$34.95**

**Solid State 2-8 Min. Timer Version . . . . \$54.95**

For all 24 or 28 pin devices—2 at a time.  
90 DAY WARRANTY SHIPPING & HANDLING  
DEALERS WELCOME \$2.50  
AZ RESIDENTS ADD 6% TAX

**WALLING CO.**  
4401 S. JUNIPER • TEMPE, AZ 85282 • (602) 838-1277

Inquiry 399

**MEMOREX FLEXIBLE DISCS**

**WE WILL NOT BE UNDER-SOLD!** Call Free (800)235-4137 for prices and information. Dealer inquiries invited and C.O.D.'s accepted.



**PACIFIC EXCHANGES**  
100 Foothill Blvd  
San Luis Obispo, CA 93401. In Cal. call (800)592-5935 or (805)543-1037

Inquiry 296

**wabash DATATECH DISKETTES**

*Value Priced Diskettes!*

**Lifetime Warranty! Hub Rings! 100% Error-Free!**

5 1/4" Diskettes Soft or Hard Sector — Boxed

SS SD .....	\$ .99 Each*
SS DD .....	\$ 1.20 Each*
DS DD .....	\$ 1.45 Each*
RDD (Flippy) .....	\$ 2.19 Each*

**SUPER SAVINGS ON BULK DISKETTES!**

SSDD .....	\$ .99
DSDD .....	\$ 1.15

Minimum order — 50 Diskettes.  
Quantity Discounts Available  
MI Residents, add 4% Sales Tax.  
Shipping & Handling \$4.00/100 Diskettes.  
**TO ORDER: Call or Write...**

**Precision Data Products**  
P.O. Box 8367  
Grand Rapids, MI 49508  
(616) 452-3457  
Michigan 1-800-632-2468  
Outside Mich. 1-800-258-0028

**C.O.D.**



Inquiry 307

**Hyperon Software**

Specializing in innovative programming tools.

- Complete documentation and C-source provided (presently DOS only).
- Reasonable prices.
- High quality and good performance.

**Products currently available:**

**C Preprocessor.** Features include variables and expressions, loops, and full macros. Price — \$39.95.

**General purpose editor.** Line oriented commands with a screen oriented submode. Command window. Price — \$29.95

Order from:  
**HYPERON SOFTWARE**  
P.O. Box 3349  
Costa Mesa, CA 92628

Enclose check or money order. California residents add 6%.

Inquiry 191

**PAL, EPROM PROGRAMMERS & UV ERASERS**

**FROM \$49.95**

**LOGICAL DEVICES INC.**

*Where Reliability and Customer Support is of utmost Importance*

SEE OUR AD ON PAGE 218

**LOGICAL**

**ORDER TOLL FREE 1-800-EEI-PROM**  
(1-800-331-7766)

Inquiry 240



# Buy your PC products direct.

Buy direct from PROGRESSIVE MICRO DISTRIBUTORS and you'll discover that low prices together with a knowledgeable sales staff can make a surprising difference.

You'll be shocked by the lucrative prices PROGRESSIVE MICRO DISTRIBUTORS can offer on one of the largest selections of PC products anywhere. But you won't be surprised by our limitless supply of expert advice, support, service and information. After all, you expect these services from your computer supplier.

But did you expect same day insured shipping, complete product warranties (some up to 5 years), and no surcharge on most credit cards? All this combined with over 25,000 square feet of computerized warehouse space assures you prompt and efficient service.

### Look Us Over and Compare.

Send for PROGRESSIVE MICRO DISTRIBUTORS Free catalog. You'll find that our catalog prices are discounted even lower than our advertised prices in national magazines. Once you start receiving our FREE catalog, you'll be entitled to free product literature and reviews by prominent industry sources at your request, as well as our monthly PRICE HOT LIST.

**MAIL** in your coupon **TODAY** to start receiving PROGRESSIVE MICRO DISTRIBUTORS monthly PRICE HOT LIST immediately. **ORDER TODAY** if you're ready to cash in on the savings right away. Call **TOLL FREE 1-800-446-7995** for a quote on any of the thousands of PC products you need.

<b>PROGRESSIVE MICRO DISTRIBUTORS</b>	BY4
<input type="checkbox"/> Please send me your FREE catalog.	
<input type="checkbox"/> Please send your monthly PRICE HOT LIST.	
<input type="checkbox"/> Please send me information on the following:	
_____	
I am a <input type="checkbox"/> new-user <input type="checkbox"/> experienced-user	
I am a <input type="checkbox"/> business-user <input type="checkbox"/> home-user	
Name _____	
Address _____	
City _____ State _____ Zip _____	
Please clip and mail to:	
7000 Peachtree Industrial Boulevard, Norcross, GA 30071	

<b>PROGRESSIVE MICRO DISTRIBUTORS</b>	BY4
<input type="checkbox"/> Please send me your FREE catalog.	
<input type="checkbox"/> Please send your monthly PRICE HOT LIST.	
<input type="checkbox"/> Please send me information on the following:	
_____	
I am a <input type="checkbox"/> new-user <input type="checkbox"/> experienced-user	
I am a <input type="checkbox"/> business-user <input type="checkbox"/> home-user	
Name _____	
Address _____	
City _____ State _____ Zip _____	
Please clip and mail to:	
7000 Peachtree Industrial Boulevard, Norcross, GA 30071	



# LOW PRICES, NAME BRANDS

To Get Your **FREE CATALOG**  
 Just Circle Reader Service #210 on Page 495.

## New Products to Expand Your PCjr.

AST 512K jrCombo w/128K	\$395	\$299. <sup>95</sup>
512K Multifunc. Card w/OK	\$295	\$229. <sup>95</sup>
External 360KB Disk Drive	\$499	\$369. <sup>95</sup>
Parallel Printer Port	\$120	\$94. <sup>95</sup>
8087 Co-Processor Card	\$199	\$149. <sup>95</sup>
Light Pen System	\$299	\$229. <sup>95</sup>
Simultaneous Disk/Keyboard	\$59	\$44. <sup>95</sup>
AST-PCnet IIjr LAN	\$495	\$399. <sup>95</sup>
TECMAR CAPTAINjr. w/128K	\$499	\$349. <sup>95</sup>

## New! from JADE IBM Multifunction Card

Up to 384K, parallel printer port, RS-232 serial port, FREE serial cable, clock/calendar, RAM disk/spooler and diagnostic software package.

	LIST	JADE
0K	\$349	\$198. <sup>95</sup>
64K	\$449	\$239. <sup>95</sup>
256K	\$549	\$349. <sup>95</sup>
384K	\$649	\$439. <sup>95</sup>

## AST for IBM PC

	LIST	JADE
Six Pak Plus 0K	N/A	\$249. <sup>95</sup>
Six Pak Plus 64K	\$395	269. <sup>95</sup>
Six Pak Plus 256K	\$695	\$399. <sup>95</sup>
Six Pak Plus 384K	\$945	\$469. <sup>95</sup>
Mega Plus 64K	\$395	\$269. <sup>95</sup>
Mega Plus 256K	\$665	\$379. <sup>95</sup>
Mega Plus 512K	\$1095	\$699. <sup>95</sup>
I/O Plus	\$165	\$129. <sup>95</sup>
Preview	\$399	\$309. <sup>95</sup>
Graphpak	\$790	\$574. <sup>95</sup>

## 64K RAM Upgrade Kits for Your IBM PC \$19.95

High speed RAM upgrade kit with FREE! parity (error detection) and one year warranty. We ship thousands of these kits to satisfied customers every week.

	LIST	JADE
128K RAM Kit for AT	\$359	\$169. <sup>95</sup>

## IBM-AT Multi-Function Expansion Board

- Up to 3 Megabytes of RAM
- Uses standard 64K or 256K chips
- Has PAL for split-addressing
- Low power, IBM-AT high speed bus
- One parallel & one serial port
- Second serial port optional

	LIST	JADE
128K, 1 serial, 1 parallel	\$495	\$395. <sup>95</sup>
Second serial port	\$59	\$49. <sup>95</sup>

## Expansion Boards for Your IBM-AT

	LIST	JADE
JADE AT-Expando Plus	\$495	\$395. <sup>95</sup>
AT-Memory Master plus	\$495	\$429. <sup>95</sup>
AST Advantage-AT	\$495	\$449. <sup>95</sup>
STB Rio Grande 128K to 1.5M	\$495	\$359. <sup>95</sup>
STB Grande Byte 128K to 2.5M	\$395	\$299. <sup>95</sup>
Quadport-AT 1S, 1P	\$154	\$139. <sup>95</sup>
4 Serial port kit	\$195	\$179. <sup>95</sup>
Quadmeg-AT 1 MEG	\$2465	\$1995. <sup>95</sup>
Quadmeg-AT 2 MEG	\$495	\$3195. <sup>95</sup>
Quadmeg-AT 4 MEG	\$7490	CALL
128K Upgrade Kit	\$395	\$169. <sup>95</sup>
20 Megabyte Hard Disk	\$1790	\$895. <sup>95</sup>

## IBM Video Boards

	LIST	JADE
Hercules Color	\$245	\$189. <sup>95</sup>
Hercules Graphic	\$499	\$339. <sup>95</sup>
Plantronics Color Plus	\$549	\$379. <sup>95</sup>
AST Preview	\$399	\$309. <sup>95</sup>
AST Monograph Plus	\$595	\$449. <sup>95</sup>
Intelligent Data TTL & RGB	\$294	\$229. <sup>95</sup>
Jade Hercules work-a-like	\$399	\$199. <sup>95</sup>
Quadcolor I	\$295	\$209. <sup>95</sup>
Quadcolor II	\$275	\$209. <sup>95</sup>
PC Peacock	\$299	\$239. <sup>95</sup>
Paradise Graphics Card	\$395	\$319. <sup>95</sup>
Paradise Module A	\$95	\$87. <sup>95</sup>
Paradise Module B	\$275	\$239. <sup>95</sup>
Everex Graphics Edge	\$599	\$389. <sup>95</sup>

## 20 MEGABYTE Tape Back-up System

- IBM PC, XT, AT compatible
- Low-power, half-height tape drive
- Uses standard data cassettes
- Unique flexible software allows choice of file-by-file or complete mirror-image back-up & retrieval
- 6 different file selection parameters
- Automatic error checking & correction
- Includes controller card & software

	LIST	JADE
20 MB cassette back-up	\$995	\$694. <sup>95</sup>
45 MB 1/4" tape back-up	\$1195	\$894. <sup>95</sup>
External 45 MB system	\$1495	\$1094. <sup>95</sup>

## 10 Megabyte Hard Disk for IBM PC \$689.00

Plug-n-run, ready to go, complete with controller card, data cable, and mounting hardware. totally PC/XT compatible, faster than XT, handles 4 different operating systems, streamer tape back-up available. External model includes cabinet & power supply. Full one year manufacturers warranty.

	LIST	JADE
10 MEGABYTE Internal	\$1795	\$689. <sup>95</sup>
10 MEGABYTE External	\$2095	\$849. <sup>95</sup>
15 MEGABYTE Internal	\$1995	\$879. <sup>95</sup>
15 MEGABYTE External	\$2295	\$1069. <sup>95</sup>
22 MEGABYTE Internal	\$2495	\$1399. <sup>95</sup>
22 MEGABYTE External	\$2795	\$1599. <sup>95</sup>
33 MEGABYTE Internal	\$3295	\$1899. <sup>95</sup>
33 MEGABYTE External	\$3395	\$1999. <sup>95</sup>
10 MEGABYTE Internal Tape	\$1000	\$579. <sup>95</sup>
10 MEGABYTE External Tape	\$1295	\$749. <sup>95</sup>

## KEYTRONICS Keyboards

	LIST	JADE
5150	\$209	\$159. <sup>95</sup>

## 2400 BAUD MODEM

- O-300, 1200, 2400 baud
- Bell 103, 113, 212A, CCITT, V.22, V.22
- Auto baud, redial, and answer
- 8 LED status indicators
- Self test & speaker volume control
- Looks like a Hayes Smartmodem
- 1200 baud & 1200B modems also avail.

	LIST	JADE
JADE 1200	\$399	\$229. <sup>95</sup>
JADE 1200B IBM PC	\$299	\$219. <sup>95</sup>
JADE 2400	\$699	\$449. <sup>95</sup>

## HAYES 1200 BAUD EXTERNAL SMARTMODEM \$429.95

	LIST	JADE
HAYES Smartmodem 2400	\$895	\$649. <sup>95</sup>
HAYES Smartmodem 1200	\$699	\$429. <sup>95</sup>
HAYES 1200B w/o Smartcom II	\$539	\$339. <sup>95</sup>
HAYES 1200B for IBM PC	\$599	\$369. <sup>95</sup>
HAYES Smartmodem 300	\$289	\$199. <sup>95</sup>
HAYES Chronograph	\$249	\$199. <sup>95</sup>
HAYES Micromodem 100	\$399	\$299. <sup>95</sup>
HAYES Micromodem IIe	\$299	\$239. <sup>95</sup>
HAYES Smartmodem IIc	\$399	\$249. <sup>95</sup>
HAYES PLEASE Software	\$395	\$299. <sup>95</sup>
HAYES Smartcom II	\$149	\$99. <sup>95</sup>

## PROMODEMS from PROMETHEUS

	LIST	JADE
1200B ProModem for IBM PC	\$399	\$289. <sup>95</sup>
1200 RS-232 ProModem	\$495	\$349. <sup>95</sup>
1200A ProModem for Apple	\$449	\$349. <sup>95</sup>
1200 ProModem for Macintosh	\$495	\$399. <sup>95</sup>
Alpha/num Display Option	\$99	\$79. <sup>95</sup>
Options Processor	\$99	\$79. <sup>95</sup>
64K Mem Expansion for Above	\$99	\$59. <sup>95</sup>



### Mouse by MOUSE SYSTEMS

	LIST	JADE
PC MOUSE with Pop-ups	\$195	\$139. <sup>95</sup>
PC MOUSE with Paint	\$220	\$159. <sup>95</sup>
FIELD MOUSE (male or female)	\$175	\$129. <sup>95</sup>
PC PAINT Software	\$99	\$69. <sup>95</sup>
MOUSE WINDOW Software	\$150	\$109. <sup>95</sup>
POP-UP MENU Software	\$50	\$39. <sup>95</sup>

### QUADRAM for IBM PC

	LIST	JADE
Quadboard No RAM	\$269	\$234. <sup>95</sup>
Quadboard 64K	\$395	\$275. <sup>95</sup>
Quadboard 128K	\$495	\$319. <sup>95</sup>
Quadboard 256K	\$595	\$399. <sup>95</sup>
Quadboard 384K	\$795	\$469. <sup>95</sup>
Quadlink	\$680	\$449. <sup>95</sup>
Quad 512 Plus 64K	\$325	\$239. <sup>95</sup>
Quad 512 Plus 256K	\$550	\$359. <sup>95</sup>
Quad 512 Plus 512K	\$895	\$549. <sup>95</sup>
Quadcolor I	\$295	\$209. <sup>95</sup>
Quadcolor II	\$275	\$209. <sup>95</sup>
Quad 2 MEG w/512K	\$1195	\$995. <sup>95</sup>
Quad 2 MEG w/1 MByte	\$1995	\$1695. <sup>95</sup>
Quad 2 MEG w/2 MByte	\$3495	\$2995. <sup>95</sup>
Palette Master 256 colors	\$695	\$599. <sup>95</sup>
Quadgraph Graphics Card	\$499	\$399. <sup>95</sup>
Quadvue IS, IP, C, monochrome	\$345	\$299. <sup>95</sup>
Asher Voice & Data	\$695	\$599. <sup>95</sup>

### TANDON TM 100-2 \$129.95 360K DISK DRIVE for IBM PC

	LIST	JADE
Double-sided, double density		
TANDON 100-2	\$299	\$129. <sup>95</sup>
TEAC 55B	\$249	\$119. <sup>95</sup>
CDC 1/2 Height	\$279	\$139. <sup>95</sup>
CDC Full Height	\$299	\$149. <sup>95</sup>

### SHUGART SA801R \$159.95

SHUGART SA 801R		
SHUGART SA 801A SS/DD (Limited Supply)		
LIST #502	\$159. <sup>95</sup> ea.	2 for \$154. <sup>95</sup> ea.
SHUGART SA-851R DS/DD		
LIST #605	\$459. <sup>95</sup> ea.	2 for \$454. <sup>95</sup> ea.

### MICROSOFT for IBM PC

	LIST	JADE
Mouse with Word	\$495	\$339. <sup>95</sup>
Mouse a la carte	\$199	\$129. <sup>95</sup>

### BERNOULLI Boxes from IOMEGA

5, 10 or 20 megabyte removable cartridge mass storage system with flexibility not available in hard disks.

5 mbyte system/Macintosh	\$1896	\$1699. <sup>95</sup>
10 mbyte system/IBM	\$2695	\$2099. <sup>95</sup>
20 mbyte system/IBM	\$3895	\$3099. <sup>95</sup>
Extra 10 mbyte cartridge	\$100	\$79. <sup>95</sup>

### Hi-Res Monitors

	LIST	JADE
Amdek 300G	\$179	\$139. <sup>95</sup>
Amdek 300A	\$199	\$149. <sup>95</sup>
Amdek 310A	\$230	\$169. <sup>95</sup>
Amdek Color 300	\$349	\$269. <sup>95</sup>
Amdek Color 500	\$525	\$399. <sup>95</sup>
Amdek Color 600	\$650	\$429. <sup>95</sup>
Amdek Color 710	\$799	\$589. <sup>95</sup>
PGS MAX-12	\$269	\$179. <sup>95</sup>
PGS HX-12 640x240	\$699	\$459. <sup>95</sup>
PGS SR-12 720x480	\$799	\$649. <sup>95</sup>
PGS Scan-Doubler	\$299	\$229. <sup>95</sup>
14 inch Quadchrome II	\$599	\$499. <sup>95</sup>
Taxan 440 Ultra Hi-res RGB	\$799	\$599. <sup>95</sup>
Taxan 210 RGB/Composite	\$349	\$289. <sup>95</sup>
Taxan TV Tuner for RGB Monitor	\$99	\$89. <sup>95</sup>

### PERSYST Boards

	LIST	JADE
Mono display adapter	\$225	\$189. <sup>95</sup>
Mono display adapter w/parallel	\$250	\$199. <sup>95</sup>
BoB Hi-res display adapter	\$595	\$469. <sup>95</sup>
Time Spectrum SB 384 w/64K	\$395	\$299. <sup>95</sup>

### High Speed 8087 APU

LIST PRICE	\$293	SALE PRICE	\$179. <sup>95</sup>
------------	-------	------------	----------------------

### ISOBAR

These industrial quality ISOBARs look like a standard multioutlet power strip but contains surge suppression circuitry and built-in noise filters plus 15 amp circuit breaker.

	LIST	JADE
4 Receptacle Iso-Bar	\$89	\$59. <sup>95</sup>
8 Receptacle Iso-Bar	\$99	\$69. <sup>95</sup>

### UNINTERRUPTABLE POWER SUPPLY

425 watts of back-up power to save your computer system and your valuable data. A must for every computer system

425 Watts UPS	\$539	\$469. <sup>95</sup>
---------------	-------	----------------------

# IBM PC \$1695 JADE XPC \$1295

256K of RAM, Two 360K Disk Drives, & Disk Controller

**IBM PC**  
256K of RAM  
63 Watt Power Supply  
5 Expansion Slots  
IBM Keyboard

**JADE XPC**  
256K of RAM  
140 Watt Power Supply  
8 Expansion Slots  
Keytronics Keyboard

### OPTION #1

256K of RAM  
Two 360K Drives  
Hercules Card  
Amdek 300  
**IBM PC** \$1995  
**JADE XPC** \$1695

### OPTION #2

256K of RAM  
Two 360K Drives  
Hercules Card  
PGS HX-12 Monitor  
**IBM PC** \$2395  
**JADE XPC** \$2095

### OPTION #3

256K Expands to 640K  
10 Megabyte Hard Disk  
One 360K Drive  
130 Watts of Power  
Multifunction Card  
Hercules Card  
Amdek 300  
**IBM PC** \$2995  
**JADE XPC** \$2695

Place Orders Toll Free!

Continental U.S.A. (800) 421-5500  
Inside California (800) 262-1710  
Los Angeles Area (213) 973-7707

# JADE Computer Products

4901 West Rosecrans Ave. Hawthorne, California 90250



## EPSON Printers New Plus Series in Stock!

EPSON P501 45 cps Thermal	\$249	\$209.95
EPSON RX-80 100 cps	\$269	\$239.95
EPSON RX-80F/T+ 100 cps	\$369	\$279.95
EPSON RX-100F/T 100cps	\$499	\$429.95
EPSON JX-80 160 cps Color	\$799	\$599.95
EPSON FX-80FT+ 160 cps	\$599	\$399.95
EPSON FX-100F/T+ 160 cps	\$849	\$599.95
EPSON LQ-1500 200 cps	\$1495	\$1099.95
EPSON/COMREX 420 cps	\$2495	\$1995.95
EPSON HI-80 4 Pen Plotter	\$599	\$489.95
4K Serial Board RX/FX	\$149	\$99.95
NLQ Board for RX/FX	\$219	\$179.95
FX-80 Tractor	\$59	\$39.95
LQ-1500 Tractor	\$89	\$49.95
LQ-1500 Sheet Feeder	\$499	\$399.95

## OKIDATA Prices Slashed \*Free IBM ROMS

160 CPS, Correspondence Quality

	LIST	JADE
Okidata 92 Parallel	\$599	\$359.95*
Okidata 93 Parallel FREE tractor!	\$995	\$589.95*
2K Serial Board	\$120	\$99.95
IBM PC ROMS for 92	\$59	\$49.95
IBM PC ROMS for 93	\$69	\$59.95
Extra 82/93 Ribbon	\$9.95	\$4.95
82/92 Tractor	\$89	\$54.95

120 CPS & 200 CPS OKIDATA

	LIST	JADE
Okidata 82 Parallel/Serial	\$499	\$299.95
Okidata 83 Parallel/Serial	\$775	\$559.95
Okidata 84 Parallel 200 CPS	\$1395	\$799.95*
Okidata 84 Serial 200 CPS	\$1495	\$949.95
2K Serial Board	\$150	\$119.95
IBM PC ROMS for 82/83	\$49	\$39.95
IBM PC ROMS for 84	\$99	\$89.95

\*FREE! Plug-n-Play option with purchase of 92, 93 or 84

## A-B Printer Switch

Fully bi-directional switch allows your computer to run either of two printers, or allows two computers to share one printer, standard parallel switch box.

	LIST	JADE
Printer Switch	\$149	\$89.95
Extra Cable	\$40	\$29.95

Continental U.S.  
**800-421-5500**

Inside California  
**800-262-1710**

For Technical Inquires  
or Customer Service call:  
**213-973-7707**

## CITIZEN Printers

Best Near-Letter-Quality printers for under \$1000!!!

	LIST	JADE
CITIZEN MSP-10 FT 160 cps	\$499	\$349.95
CITIZEN MSP-15 FT 160 cps	\$749	\$529.95
CITIZEN MSP-20 FT 200 cps	\$699	\$489.95
CITIZEN MSP-25 FT 200 cps	\$949	\$669.95
CITIZEN Serial Option	\$60	\$49.95

## Printer Accessories

	LIST	JADE
IBM PC style cable	\$54	\$28.95
Standard parallel cable	\$40	\$28.95
Dual Printer Switch Box	\$149	\$89.95
Apple Card & cable	\$109	\$49.95
RS-232 serial cable	\$30	\$24.95
Ribbons	as low as	\$4.99
Apple IIC cable	\$39	\$27.95

**SUPER DISKETTE SPECIAL**  
Perfect for IBM, Apple,  
Kaypro, etc.

Ultra-high quality diskettes from a premium U.S. manufacturer, certified to be absolutely error free for one full year. Buy a box of ten this month and we will include a plastic storage/library box FREE!

	LIST	JADE
Single-sided, double-density	\$34	\$16.50
Double-sided, double-density	\$42	\$19.50
Bulk Diskettes as low as		\$1.10



# PRINTERS ON SALE!!!

## C. ITOH Printers

C. Itoh's best-selling ProWriter and StarWriter printers are now available with parallel interfaces for Apple & IBM, or a serial interface for Apple IIc, Macintosh, Data General, etc. Full one year manufacturers warranty.

	LIST	JADE
ProWriter 7500 FT 105 cps	\$289	\$209.95
ProWriter 8510 FT 120 cps	\$429	\$299.95
ProWriter II 1550 FT 120 cps	\$619	\$439.95
StarWriter Y10-20 20 cps	\$489	\$359.95
StarWriter F10-30 29 cps	\$669	\$479.95
StarWriter F10-40 40 cps	\$1199	\$899.95
StarWriter F10-55 58 cps	\$1449	\$1089.95
StarWriter F10 Tractor	\$249	\$159.95
StarWriter A10 Tractor	\$199	\$139.95

## Letter Quality Printers On Sale!

	LIST	JADE
Diablo 630 40 CPS	\$2340	\$1569.95
Tractor for 630	\$250	\$219.95
Comrex CR-IIe	\$599	\$399.95
Tractor for CR-IIe	\$120	\$99.95
Keyboard for CR-IIe	\$199	\$179.95
Sheet feeder for CR-IIe	\$259	\$199.95
Juki 6100 18 CPS	\$599	\$399.95
Tractor for 6100	\$149	\$124.95
NEC 3550 33 CPS	\$2250	\$1399.95
Tractor for 3550	\$265	\$229.95
Toshiba P1351	\$1895	\$1289.95
P1351 Tractor	\$195	\$174.95
P1351 Sheet Feeder	\$1095	\$899.95

## Ultra-Violet EPROM Erasers

	LIST	JADE
Spectronics with out Timer	\$99	\$69.95
Spectronics with Timer	\$139	\$94.95

## The LITTLE BOARD with FREE! CP/M 2.2

Miniature single board CP/M computer designed to mount directly on top of a 5¼" floppy disk drive (7.75" x 5.75"). Contains Z80A CPU, 64K RAM, Boot EPROM, terminal port, modem port, parallel printer port, floppy disk controller, and CP/M 2.2 included FREE!

	LIST	JADE
Little Board with CP/M	\$400	\$349.95
Support Package	\$50	\$48.95
Serial Cable	\$13	\$11.95
Diskless Monitor Eprom	\$30	\$24.95

## QUADRAM MICROFAZER Buffers

Expandable to 64K (parallel model expands to 512K)

8K Parallel in/Parallel out	\$169	\$139.95
32K Parallel in/Parallel out	\$225	\$164.95
128K Parallel in/Parallel out	\$445	\$269.95
8K Serial in/Parallel out	\$199	\$169.95
32K Serial in/Parallel out	\$260	\$199.95
8K Parallel in/Serial out	\$199	\$169.95
32K Parallel in/Serial out	\$260	\$199.95
8K Serial in/Serial out	\$199	\$169.95
32K Serial in/Serial out	\$260	\$199.95

## PRACTICAL PERIPHERAL MICROBUFFERS

Stand alone Microbuffers for Printers & Modems

	LIST	JADE
32K Parallel in/Parallel out	\$299	\$229.95
64K Parallel in/Parallel out	\$349	\$269.95
32K Serial in/Serial out	\$299	\$229.95
64K Serial in/Serial out	\$349	\$269.95
64K Add-on Board	\$179	\$149.95

We accept cash, checks, credit cards, or purchase orders from qualified firms and institutions.  
Minimum prepaid order \$15.00 California residents add 6½% tax. Export customers outside the US or Canada please add 10% to all prices. Prices and availability subject to change without notice. Shipping and handling charges via UPS Ground 50¢/lb. UPS Air \$1.00/lb. minimum charge \$3.00

# JADE Computer Products



# BUY UNITED STATES SAVINGS BONDS



## Subscription Problems?



### We want to help!

If you have a problem with your **BYTE** subscription, write us with the details. We'll do our best to set it right. But we must have the name, address, and zip of the subscription (new and old address, if it's a change of address). If the problem involves a payment, be sure to include copies of the credit card statement, or front and back of cancelled checks. Include a "business hours" phone number if possible.

**BYTE**  
Subscriber Service  
P.O. Box 328  
Hancock, NH 03458

# Future Shock!

age **65**  
years worked **40**  
retirement benefits **0**

The U.S. Department of Labor has a free booklet that will help you answer these questions and a lot more. Send for it today. Write: Pensions, Consumer Information Center, Pueblo, Colorado 81009

U.S. Department of Labor

## RAM • RAM • RAM

64K 150 NS 64K x 1 \$2.00

256K 150NS 256K x 1 \$10.50

- \* PARTS IN STOCK
- \* FACTORY NEW, PRIME PARTS
- \* WILL MEET MOST ADVERTISED PRICES \*
- \* NEXT DAY SHIPMENT \*

### E.C.I.

P.O. BOX 8067  
FOUNTAIN VALLEY, CA 92728  
TELEX: 910 997 6120 EARTH FV  
CALL: (714) 964-5784

Inquiry 436

## IBM™/APPLE™/COMMODORE™ BARECOM™ MODEM

ADD-ON MODEM FOR  
PERSONAL COMPUTER

- BELL 103 AND/OR 212 COMPATIBLE
- CCITT V 21 AND/OR V 23 COMPATIBLE
- AUTO DIAL/ANSWER/DISCONNECTION
- FREE OF CHARGE COMMUNICATION SOFTWARE

DEALERS AND DISTRIBUTER INVITED.  
OEM DESIGN/MANUFACTURE  
WELCOMED



P.O. BOX 58144 TAIPEI, TAIWAN, R.O.C.  
TELEX: 20370 COMPOWER  
TEL: (02) 3937976, 3213060

Inquiry 437

## Your I.C. Connection (213) 516-7018

<b>DYNAMIC RAMS</b>	
4164-150NS	2.45
<b>STATIC RAMS</b>	
2016P-1 (100NS)	4.45
6116P-3 (150NS)	3.75
<b>EPROMS</b>	
2716-450NS	3.00
2532-450NS	4.50

**MANY OTHERS IN STOCK  
CALL FOR SPECIAL PRICES**

- Low, low prices
- Top Quality Parts
- Wide Selection
- Fast Delivery



13760 Grammercy Place  
Gardena, CA 90249  
TLX: 664747 HYEXIM FAX: (213) 217-0363

Inquiry 148

## VT100 or D200 on your PC, jr, XT, AT or compatible

ZSTEMpc-VT100 Smart Terminal Emulator  
132-col. by windowing-no addit. hardware  
Double High/Double Wide Characters  
Full VT100 line graphics. Smooth scrolling  
2-way file transfers incl. XMODEM  
Full keyboard softkeys/MACROS  
Speeds to 38.4KB. High Throughput  
ZSTEMpc-VT100 \$150. ZSTEMpc-D200 \$125.  
30 day money back guarantee. MC/VISA.

ZSTEM Communications Division  
KEA SYSTEMS LTD.  
#412-2150 W. Broadway  
Vancouver, B.C. CANADA V6K 4L9  
Support (604) 732-7411  
Orders (800) 663-8702

Inquiry 407

## INVENTORY CLEARANCE! IMMEDIATE DELIVERY!

### General DataComm Dial Modems



**103J-L**  
300 bps,  
full duplex. \$99.00

**113A** 300 bps, full duplex. Reliable LSI design. \$149.00

**212A** 1200 bps full duplex synch or asynch. 300 bps synch. \$299.00

We also have quantities of 4800 and 9600 bps modems.

**Call Toll Free 1-800-842-3672**

**General DataComm**  
Middlebury, CT 06762-1299

Add \$5.00 shipping and handling  
Conn. res. add sales tax.

Inquiry 430

## Two Dollars SALE

Each book from this ad is two Dollars! Buy all 12 books for only \$19.95!  
Incredible savings—Mail your order today!

**BOOKS FOR THE  
COMMODORE 64**  
\*\*\*\*\*  
The Great Book of Games  
45 games, 144 pages  
Order-No. 152 was \$ 9.95 now \$ 2.-

More on the Sixtyfour  
Machine Language Programs for the  
advanced user.  
Order-No. 183 was \$ 9.95 now \$ 2.-

Machine Language Programming on  
the C-64  
Order-No. 184 was \$ 12.95  
now \$ 2.-

Commodore-64 Tune-up  
Hardware expansions, I/O program-  
ming, A/D conversion  
Order-No. 185 was \$ 12.95  
now \$ 2.-

Small Business Programs for the C-64  
Order-No. 186 was \$ 12.95  
now \$ 2.-

29 Programs for the C-64  
Order-No. 55 was \$ 9.95 now \$ 2.-

The programs from the books are also available on disk. Each disk is \$ 9.95.

\*\*\*\*\*

**ELCOM PUBLISHING, INC.**  
2174 West Foothill Blvd., Unit E  
Upland, CA 91786  
Phone: (714) 985-4477, Telex: 29 81 91

**ATARI Machine Language  
Programming**  
Order-No. 169 was \$ 9.95 now \$ 2.-

**Hackerbook for the ATARI**  
Order-No. 172 was \$ 9.95 now \$ 2.-

\*\*\*\*\*

**BASIC in 60 Minutes — a day**  
Order-No. 36 was \$ 7.95 now \$ 2.-

**PAYMENT:** Money Order, VISA, MC  
CA residents add 5% sales tax  
Add \$ 2.00 per book for S&H (less \$ 10.-)  
Outside USA, add \$ 20.00 for shipping

Inquiry 137



# Do Kay

COMPUTER  
PRODUCTS,  
Inc.

ORDER TOLL FREE

(800)  
538-8800

(CALIFORNIA RESIDENTS)

(800)  
848-8008

VISA

MasterCard

## STATIC RAMS

2101	256 x 4 (40ns)	1.90
5101	256 x 4 (450ns) (cmos)	3.90
2102-1	1024 x 1 (450ns)	.79
2102L-4	1024 x 1 (450ns) (LP)	.29
2102L-2	1024 x 1 (250ns) (LP)	1.29
2111	256 x 4 (450ns)	2.29
2112	256 x 4 (450ns)	2.29
2114	1024 x 4 (450ns)	.99
2114-25	1024 x 4 (250ns)	1.10
2114L-4	1024 x 4 (450ns) (LP)	1.20
2114L-3	1024 x 4 (300ns) (LP)	1.30
2114L-2	1024 x 4 (200ns) (LP)	1.40
2147	4096 x 1 (55ns)	3.95
TMS4044-4	4096 x 1 (450ns)	2.95
TMS4044-3	4096 x 1 (300ns)	3.45
TMS4044-2	4096 x 1 (200ns)	3.95
MC4118	1024 x 1 (250ns)	8.95
TMM2016-20	2048 x 8 (200ns)	3.95
TMM2016-15	2048 x 8 (150ns)	4.45
TMM2016-10	2048 x 8 (100ns)	5.95
HM6116-4	2048 x 8 (200ns) (cmos)	4.40
HM6116-3	2048 x 8 (150ns) (cmos)	4.90
HM6116-2	2048 x 8 (120ns) (cmos)	5.90
HM6116LP-4	2048 x 8 (200ns) (cmos) (LP)	4.90
HM6116LP-3	2048 x 8 (150ns) (cmos) (LP)	5.90
HM6116LP-2	2048 x 8 (120ns) (cmos) (LP)	7.90
Z-9132	4096 x 8 (300ns) (9vcm)	28.95
HM8284P-15	8192 x 8 (150ns) (cmos) (LP)	18.95
HM8284LP-15	8192 x 8 (150ns) (cmos) (LP)	22.95
HM8284LP-12	8192 x 8 (120ns) (cmos) (LP)	24.95

LP = Low Power Qstat = Quasi-Static

## DYNAMIC RAMS

TMS4027	4096 x 1 (250ns)	1.45
UP0411	4096 x 1 (300ns)	1.95
MM5280	4096 x 1 (300ns)	1.95
MC4118	8192 x 1 (200ns)	.79
MM5298	8192 x 1 (250ns)	.49
4116-20	16384 x 1 (200ns)	.99
4116-15	16384 x 1 (150ns)	.99
4116-12	16384 x 1 (120ns)	1.49
2118	16384 x 1 (150ns) (5v)	3.95
4164-25	65536 x 1 (250ns) (5v)	2.00
4164-20	65536 x 1 (200ns) (5v)	2.22
4164-15	65536 x 1 (150ns) (5v)	2.50
41256-20	262144 x 1 (200ns)	12.95
41256-15	262144 x 1 (150ns)	15.95

5V = Single 5 Volt Supply

## EPROMS

1702	256 x 8 (1us)	3.95
2708	1024 x 8 (450ns)	2.49
2758	1024 x 8 (450ns)	5.90
2716	2048 x 8 (450ns) (5v)	2.95
2716-1	2048 x 8 (350ns) (5v)	3.95
TMS2516	2048 x 8 (450ns) (5v)	3.95
TMS2716	2048 x 8 (450ns) (5v)	3.95
TMS2532	4096 x 8 (450ns) (5v)	6.95
2732	4096 x 8 (450ns) (5v)	3.95
2732 A-4	4096 x 8 (450ns) (21v)	3.95
2732 A-35	4096 x 8 (350ns) (21v)	3.95
2732 A	4096 x 8 (250ns) (21v)	5.95
2732 A-2	4096 x 8 (200ns) (21v)	8.95
2764	8192 x 8 (450ns) (5v)	4.95
2764-25	8192 x 8 (250ns) (5v)	5.95
2764-20	8192 x 8 (200ns) (5v)	9.95
TMS2564	8192 x 8 (450ns) (5v)	8.95
MC808764	8192 x 8 (450ns) (5v) (24-pin)	17.95
MC808768	8192 x 8 (450ns) (5v) (24-pin)	18.95
27128-45	16384 x 8 (250ns) (5v)	14.95
27128-30	16384 x 8 (300ns) (5v)	16.85
27128-25	16384 x 8 (250ns) (5v)	18.95
27256-25	32768 x 8 (250ns) (14v)	79.95

5v = Single 5 Volt Supply

## 74LS00

74LS00	23	74LS125	.48	74LS260	.58
74LS01	24	74LS126	.48	74LS266	.54
74LS02	24	74LS128	.58	74LS273	1.45
74LS03	24	74LS133	.58	74LS275	3.30
74LS04	23	74LS136	.38	74LS279	.48
74LS05	24	74LS137	.98	74LS280	1.95
74LS08	27	74LS138	.54	74LS283	.88
74LS09	28	74LS139	.54	74LS290	.88
74LS10	24	74LS145	1.15	74LS293	.88
74LS11	34	74LS147	2.45	74LS295	.98
74LS12	34	74LS148	1.30	74LS298	.88
74LS13	44	74LS151	.54	74LS299	1.70
74LS14	58	74LS153	.54	74LS323	3.45
74LS15	34	74LS154	1.85	74LS324	1.70
74LS20	24	74LS155	.68	74LS352	1.25
74LS21	28	74LS156	.68	74LS353	1.25
74LS22	24	74LS157	.84	74LS353	1.30
74LS26	28	74LS158	.58	74LS364	1.90
74LS27	28	74LS160	.68	74LS365	.48
74LS28	34	74LS161	.84	74LS366	.48
74LS30	24	74LS162	.68	74LS367	.44
74LS32	28	74LS163	.84	74LS368	.44
74LS33	54	74LS164	.68	74LS373	1.35
74LS37	34	74LS165	.94	74LS374	1.35
74LS38	34	74LS166	1.90	74LS377	1.35
74LS40	24	74LS169	1.70	74LS378	1.13
74LS42	48	74LS189	1.70	74LS378	1.30
74LS47	74	74LS170	1.45	74LS385	1.85
74LS48	74	74LS173	.68	74LS386	.44
74LS49	74	74LS174	.54	74LS390	1.15
74LS51	24	74LS175	.54	74LS393	1.15
74LS54	28	74LS181	2.10	74LS395	1.15
74LS55	28	74LS189	0.90	74LS399	1.45
74LS63	1.20	74LS190	.88	74LS424	2.90
74LS73	38	74LS191	.88	74LS447	.38
74LS74	34	74LS192	.78	74LS490	1.90
74LS75	38	74LS193	.78	74LS624	3.95
74LS76	38	74LS194	.88	74LS640	2.15
74LS78	48	74LS195	.88	74LS645	2.15
74LS83	58	74LS196	.78	74LS668	1.85
74LS85	88	74LS197	.78	74LS669	1.85
74LS88	38	74LS221	.88	74LS670	1.45
74LS90	54	74LS240	.84	74LS674	9.80
74LS91	88	74LS241	.98	74LS682	3.15
74LS92	54	74LS242	.98	74LS683	3.15
74LS93	54	74LS243	.98	74LS684	3.15
74LS95	74	74LS244	1.25	74LS685	3.15
74LS96	88	74LS245	1.45	74LS688	2.35
74LS107	38	74LS247	.74	74LS689	2.35
74LS109	38	74LS248	.98	74LS783	3.15
74LS112	38	74LS249	.98	81LS95	1.45
74LS113	38	74LS251	.58	81LS96	1.45
74LS114	38	74LS253	.58	81LS97	1.45
74LS122	44	74LS257	.58	81LS98	1.45
74LS123	78	74LS258	.58	25LS2521	2.75
74LS124	2.85	74LS259	2.70	25LS2568	4.20

## CRT CONTROLLERS

6845	11.95	8275	28.95
68845	18.95	7220	38.95
HO46505sp	11.95	CNT5027	18.95
6847	10.95	CNT5037	28.95
MC1372	6.90	TMS9918A	36.95
68047	23.95	DPB350	48.95

## DISC CONTROLLERS

1771	14.95	2797	54.95
1791	21.95	6843	33.95
1793	25.95	8272	18.95
1795	21.95	UPD785	18.95
1797	21.95	MM8876	23.95
2791	49.95	MM8877	25.95
2793	49.95	1691	6.95
2795	54.95	2143	6.95

## UV ERASERS

QUV-T8/1 \$49.95  
ECONOMY Model



- Erases 15 EPROMs in 20 minutes
- Plastic Enclosure

## 6500

1 MHz		2 MHz	
65022	4.90	6502A	5.90
6504	6.90	6520A	5.90
6505	8.90	6522A	9.90
6507	8.90	6532A	10.90
6520	4.30	6545A	12.90
6522	4.90	6551A	10.90
6532	9.90		
6545	9.90		
6551	9.90	6502B	7.90

## 6800

1 MHz		68B00	
		2 MHz	
6800	2.90	68B00	9.90
6802	7.90		
6803	17.90	68B02	11.90
6808	12.90	68B09	11.90
6809E	6.90	68B09E	11.90
6809	8.90	68B09E	11.90
6810	2.90	68B10	5.90
6820	4.30	68B21	5.90
6821	2.90	68B40	18.90
6828	13.90	68B45	18.90
6840	11.90		
6843	33.90		
6844	24.90		
6845	11.90		
6847	10.90	68000-8	34.90
6850	2.90	68047	23.90
6852	5.90	68A08	18.90
6860	7.90	68B52	14.90
6882	10.90	68B61	8.90
6875	8.90	68B64	17.95
6880	1.90	68B68	19.95
6883	21.90	68B68	19.95

## 8000

8031	14.90	8253	6.90
8035	5.80	8253-5	7.90
8038	18.90	8255	4.45
IM8-8060	18.90	8255-5	4.90
IM8-8073	29.90	8257	7.90
8080A	3.90	8257-5	8.90
8085	4.90	8259	5.90
8085A-2	11.90	8259-5	6.90
8086	24.90	8271	6.90
8087-3 (5 MHz)	159.90	8272	19.90
8087-2 (8MHz)	279.90	8274	28.90
8088	19.90	8275	28.90
8089	59.90	8279	6.90
		8279-5	7.90
		8282	6.45
		8283	6.45
		8284	4.90
		8286	6.45
		8287	6.45
		8288	12.90
		8289	44.90
		8292	12.90

## 8100

8131	2.90	8284	4.90
8155	6.90	8286	6.45
8155-2	7.90	8287	6.45
8156	6.90	8288	12.90
8185	28.90	8289	44.90
8185-2	38.90	8292	12.90

## 8200

8202	23.90	8303	2.90
8203	38.90	8304	1.90
8205	2.90	8307	2.90
8212	1.75	8308	2.90
8214	3.75	8310	3.90
8216	1.75	8311	3.90
8224	2.20		
8226	1.75		
8228	3.45	8741	28.90
8237	12.90	8748	19.90
8237-5	14.90	8749	28.90
8238	4.45	8755	23.90
8243	4.45		
8250	9.90		
8251	3.90	80186-6	89.90
8251A	4.45	80186	89.90

## 2 MHz

Z80-CPU	1.95	Z80A-810/0	9.95
Z80-CTC	1.95	Z80A-810/1	9.95
Z80-DART	6.95	Z80A-810/2	9.95
Z80-DMA	7.95	Z80A-810/9	9.95
Z80-PIO	1.95		
Z80-810/0	8.95		
Z80-810/1	8.95	Z80B-CPU	7.95
Z80-810/2	8.95	Z80B-CTC	8.95
Z80-810/9	8.95	Z80B-PIO	8.95
		Z80B-DART	18.95
		Z80B-810/0	28.95
		Z80 810/2	28.95

## 4 MHz



## ROBOT KITS! PIPER-MOUSE

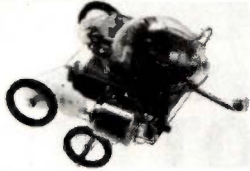

Controlled by sound sensor and 1-channel electronic circuit. Use the whistle in this kit and Piper-Mouse follows your commands, turning left or right, stopping and starting. Uses 2 AA and 1 9V battery (not included).

**MV-915 \$44.95**  
**RIBBON CABLE**

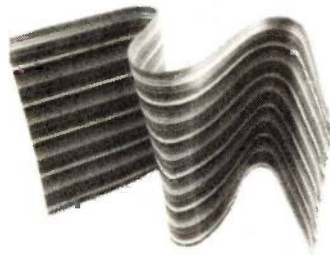

CONTACTS	SINGLE COLOR		COLOR CODED	
	1'	10'	1'	10''
10	.45	4.30	.70	7.20
16	.50	4.70	.95	8.70
20	.60	5.80	1.15	10.80
25	.70	6.50	1.22	11.50
28	.70	6.50	1.27	11.50
34	.93	8.50	1.55	14.40
40	1.27	11.50	1.82	16.70
50	1.28	12.00	2.40	21.90

## RESISTORS

1/4 WATT 5% CARBON FILM  
ALL STANDARD VALUES  
FROM 1 OHM - 10 MEG OHM  
50 PCS ..... 1.25  
100 PCS ..... 2.00  
1,000 PCS ..... 15.00



**Checkmate  
Technology,  
Inc.**

**APPLE IIe Special**  
**Extended 80-Col.**  
**VIDEO CARD**  
**\$69.95**

★ 64K to 128K ★  
**MULTIVIEW 80/160 249.00**

3-160 columns with any monitor!

Screens: 80x24, 80x32, 80x48,  
96x24, 132x24, 132x30, 160x24

On-screen **BOLD** and **Underline**

Reverse scrolling

Easy-to-read *Wide-angle* mode

Apple II and IIe compatible

Prompt lines

Upper & lowercase letters



# APPLE & IBM ACCESSORIES

80 Column Apple II+ ... 149.95  
80 Column Apple IIe ... 119.95  
Z80 Apple II+ ..... 89.00  
Z80 Apple IIe ..... 89.00  
16K Card ..... 39.95  
Cooling Fan ..... 38.95  
Power Supply ..... 74.95  
Joystick ..... 29.95  
RF Modulator ..... 13.95  
Disk Drive ..... 169.95  
Controller Card ..... 59.95  
Paddles ..... 7.95

**micromax**  
INNOVATORS IN MICRO-COMPUTER TECHNOLOGY

**VIEWMAX-80 149.95**

80-Column card for Apple II series

- Video Soft Switch
- Inverse Video
- VIDEX's Videoterm compatible



**VIEWMAX-80e 119.95**

80-Column extended video card for  
Apple IIe

- 64K RAM, expandable to 128K
- Double High-resolution circuit
- Compatible with Pascal & CP/M



**PRINTMAX 59.95**

Parallel printer card, Apple II series

- Centronics compatible
- Variable print widths
- Up to 5000 characters/second

**APPLE & IBM Compatible  
DISK DRIVES**



- Shugart mechanism, made in U.S.A.
- Directly replaces Apple Disk II
- Fully compatible with Apple Controller or other Apple compatible controllers.
- One Year Warranty

**FULL or 1/2-Height**

**16K RAM Card - Apple II+**

- 2-Year Warranty



Assembled & Tested .... **39.95**

**APPLE or IBM JOYSTICK**

**\$29.95**

Compatible for either:

**APPLE II and APPLE IIe**

OR

**IBM-PC, JR., & IBM-XT**

**MULTIFUNCTION CARD**



- 64K to 384K RAM
- Parallel Port
- Serial Port
- Clock Calendar
- Software Included
- 1-Year Warranty

**\$249.95**

**MEMORY CARD**



- Expandable to 512K
- Fully compatible with IBM software
- Fully compatible w/IBM diagnostic utilities
- Serial Port Available
- 1-Year Warranty

**\$199.95**

**MEMORY  
EXPANSION KIT**



**4164 200ns**  
**9 for \$19.98**

**DISKETTES**

**5 1/4"**

**ATHANA: ( SOFT SECTOR  
w/HUB RING )**

**25 per package**

**SS/DD ..... 29.75 or 1.19 ea.**  
**DS/DD ..... 34.75 or 1.39 ea.**

**LIFETIME WARRANTY  
ON ALL ATHANA DISKETTES**

**NO LABEL: ( SOFT SECTOR  
w/HUB RING )**

**25 per package**

**SS/DD ..... 24.75 or .99 ea.**  
**DS/DD ..... 29.75 or 1.19 ea.**

**2-YEAR WARRANTY  
ON ALL BULK DISKETTES**

## ROBOT KITS! PEPPY



2-way sensor detects noise or solid objects in its path. When front sensor contacts an obstacle or hears a loud noise (hand-clap), Peppy automatically turns to the left.

Uses 2 AA and 1 9V battery (not included).

**MV-916 \$24.95**

**Reg. Power Supply  
Model 4A/PS (99/4)**

**3 DC Outputs:**

**12V @ .4A, +5V @ 1.1A  
-5V @ .2A Highly Filtered**

**6.95**



**KEYBOARD (99/4)**



**48 keys 4" x 10" 6.95**

**TERMS:** Minimum order \$10.00  
For shipping and handling, include  
\$2.50 for UPS ground or \$3.50 for  
UPS Blue (air) For each additional  
air pound, add \$1 for UPS Blue  
shipping and handling. California  
residents must include 6% sales  
tax. Bay area and LA residents in-  
clude 6 1/2% sales tax. Prices are  
subject to change without notice.  
We are not responsible for typo-  
graphical errors. We reserve the  
right to limit quantities and to sub-  
stitute manufacturers. All merchan-  
dise subject to prior sale

**CALL for VOLUME Quotes**

**HOURS:** Mon. - Fri. 7:30 to 5:00  
Saturdays 10:00 to 3:00

VISIT OUR RETAIL STORE

2100 De La Cruz Blvd.  
Santa Clara, CA 95050  
(408) 988-0697

**ALL MERCHANDISE IS  
100% GUARANTEED**

**Telex: 756440**

**Do Kay**



# California Digital

17700 Figueroa Street • Carson, California 90248

## NEC RGB COLOR MONITOR \$259



The NEC JC-1401D is a 13" medium/high resolution RGB monitor suitable for use with the Sanyo MBC-550/555 or the IBM/PC. The monitor features a resolution of 400 dots by 240 lines. Colors available are Red, Green, Blue, Yellow, Cyan, Magenta, Black and White. These monitors are currently being used in applications far more critical than microcomputers. The NEC monitor carries the Litton-Monroe label and was originally scheduled for use in their "Office of the Future" equipment. A change in Monroe's marketing strategy has made these units excess inventory which were sold to California Digital. We are offering these prime new RGB monitors at a fraction of their original cost. Sanyo compatible NEC-1401/S, IBM/PC Computer compatible NEC-1401/PC.

## COMPUTER PLOTTER

\$219



The Comrex Comscribe I is the ideal solution to make short work of translating financial and numeric data into a graphic presentation.

Many ready to run programs such as Lotus 1-2-3, Visi-on and Apple business graphics already support this plotter.

The Comscribe I features programmable paper sizes up to 8 1/2" by 120 inches, 6 inch per second plot speed and 0.004" step size.

Easy to implement Centronics interface allows the Comscribe I immediate use with the printer port of

most personal computers.

The Comscribe I is manufactured for Comrex by the Enter Computer Corporation. The plotter is marketed by Heath Kit and also sold under Enters own "Sweet P" label. This is your opportunity to purchase a graphic plotter which was originally priced at \$795 for only \$219.

Also available is a support package which includes demonstration software, interface cable, amulicorpen assortment and a variety of paper and transparency material.

## MONITORS

BMC 12A green phosphor 15 MHz composite video  
BMC 12 high resolution 20MHz  
Amdek 300A 12" green phosphor  
Amdek 300A 12" amber phosphor  
Amdek 310A designed for IBM/PC, amber  
Zenith ZVM122 Amber Phosphor 12" 40/80 column switch  
Zenith ZVM123 green phosphor 12" 40/80 column switch  
NEC JB1201 green phosphor 18 MHz composite video  
NEC JB1260 commercial grade composite  
Comdex 9" open frame requires host sync, & 12v supply

BMC 12A 78.95  
BMC-12EN 119.00  
AMK-300G 128.95  
AMK-300A 138.95  
AMK-310A 158.95  
ZTH-122 89.95  
ZTH-123 89.95  
NEC-JB1201 158.00  
NEC-JB1260 130.00  
CON-BW9 59.00

### COLOR

NEC JC1401D Medium/High 13" RGB  
BMC AU919111 Color composite video with sound  
BMC 9191M RGB designed for use with the IBM computer  
NEC JC1203DM RGB color monitor  
NEC JC1215 color composite video  
Zenith ZVM135 RGB & composite suitable for IBM/PC  
Amdek Color I 13" composite video  
Amdek Color II 13" RGB in resolution  
Amdek Color III 13" RGB medium resolution  
Pricertron HX-12 RGB IBM/PC compatible

NEC-1401/K 258.00  
BMC-9191M 378.00  
NEC-1203 699.00  
NEC-1215 339.00  
ZTH-2135 475.00  
AMK-100 299.00  
AMK-200 419.95  
AMK-300 359.95  
PRN-HX12 478.95

## 1200 BAUD MODEM

The Team 212A offers all the features of the Hayes Smart Modem 1200 for a fraction of the price. Now is your opportunity to purchase a 1200 baud modem at the price of a 300 baud modem.

California Digital is so confident of your complete satisfaction that we will allow the return the Team 212A and apply the full credit towards the purchase of any other 1200 baud modem. TEM-SM1200



\$229

## PRINTERS

### MATRIX PRINTERS

Siar Gemini-10X 120 char/sec  
Siar Gemini-15X 100 char/sec 15 paper  
Siar Gemini Delta 160 Char/sec  
Toshiba P1351 192 char/sec letter quality  
Okidata 82A serial & parallel 9" paper  
Okidata 92A parallel interface 160 char/sec  
Okidata 85A & parallel 15 paper  
Okidata 84A & parallel 15 paper  
Epson RX-80 10 120 Char/sec  
Epson RX-80/FT tractor  
Epson FX80FT 10 160 char/sec with graphitax  
Epson FX100FT 15 160 char/sec with graphitax  
Epson LXJ 500 15 correspondence quality  
Epson JX80 Color printer  
Prowriter 8510 parallel 9" paper  
Prowriter II parallel 15 paper graphics  
Dataarcade B-800-3, band printer 600 LPM  
Printpro 2300 high speed printer 300 lines per minute  
Printpro 1600 ultra high speed 600 lines per minute

STR-G10X 249.00  
STR-G15X 365.00  
STR-D10 105.00  
TOS-1351 185.00  
OKI-82A 299.00  
OKI-92A 379.00  
OKI-85A 549.00  
OKI-84A 929.00  
EPS-RX80 239.00  
EPS-RX80FT 279.00  
EPS-FX80 399.00  
EPS-FX100 599.00  
EPS-LD1500 1079.00  
EPS-JX80 579.00  
PRD-8510P 329.00  
PRD-8510 399.00  
DPS-B600 699.00  
PTX-P600 399.00  
PTX-P600 579.00

### WORD PROCESSING PRINTERS

Stanwriter F10 parallel, 40 char/sec  
NECB810 55 char/sec serial interface  
NECB830 55 char/sec par interface  
NEC3550 popular printer designed for the IBM PC  
NEC2050 designed for IBM PC 20 char/sec par I  
Silver Reed EXP500 14 char/sec par I interface  
Silver Reed EXP550 17 char/sec par I interface  
Diablo 630 30 char/sec serial  
Diablo 620 proportional spacing horz & vert tab 20 cps  
Juki 6100 18 char/sec  
Juki 6300 40 char/sec  
Comrex CR2 5k buffer proportional spacing par I

PRO-F10P 199.00  
NEC-8810 1859.00  
NEC-8830 1859.00  
NEC-3550 1599.00  
NEC-2050 689.00  
SRI-EXP500 319.00  
SRI-EXP550 429.00  
DBL-630 1569.00  
DBL-620 769.00  
JUK-6100 399.00  
JUK-6300 699.00  
CRX-CR2P 395.00

## PROMETHEUS ProModem 1200



\$319

The Prometheus ProModem 1200 is best value that we have seen in a 300 1200 baud modem. This Hayes compatible modem features completely unattended operation, auto answer/auto dial and even includes a redial number when busy. Internal diagnostics makes the ProModem 1200 an easy modem to install. Help commands, real time clock and internal speaker add to the ease of use of this unit.

An optional processor accessory allows battery back up, extra memory space for storing additional phone numbers, messages received, and can act as a transfer buffer when exchanging programs. The Alphanumerical display option allows messages saved to be displayed when they were received, diagnostic test results, numbers in the directory, as well as modem status.

## MODEMS

Team 1200 Hayes Compatible  
CTS 212AH 1200 baud, auto dial  
Terminal software for CTS 212AH  
Prometheus 1200 super features  
Prometheus 1200B external PC  
Signalman Mark 12 1200 baud Hayes compatible  
Signalman Mark 12 direct connect with terminal cable  
Hayes Smart Modem 1200 baud, auto answer, auto dial  
Hayes 1200B for use with the IBM/PC 1200 baud  
Hayes Smartmodem 300 baud only auto answer auto dial  
Ingres Micromodem II 103 Apple direct connect  
Hayes Chronograph time & date  
U.S. Robotics 212A 300 1200 baud, auto dial answer  
Perbit 300 1200 industrial quality  
Universal Data 103LP line power answer & originate  
Universal Data 202 1200 baud null duplex only  
Universal Data 212LP full 1200 baud duplex line power  
Navigation J Call direct connect auto answer

TEM-SM1200 229.00  
CTS-212AH 259.00  
CTS-212SFT 35.00  
PHM-1200 319.00  
EIM-103/12 279.00  
SGL-MK12 239.00  
SGL-MK1 75.00  
HYS-212AD 429.00  
HYS-1200B 399.00  
HYS-103AD 299.00  
HYS-MM2 279.00  
HYS-CHR232 199.00  
USR-212A 439.00  
PEN-12AD 395.00  
UDS-103LP 169.00  
UDS-202LP 219.00  
UDS-212LP 359.00  
NOV-JCAT 115.00



EAGLE \$895

The Eagle IIE/2 Computer features a 12" non-glare green phosphor CRT, typewriter style keyboard with separate numeric cluster. This unit provides two 5 1/4" drives for a combined storage capacity of 780 K/Byte. The computer contains a 4MHz Z-80A, DMA disk interface, two RS-232C serial ports, Centronics printer interface along with an auxiliary parallel port.

Software included consists of ULTRACALC electronic spread sheet, SPELLBINDER word processor, GBASIC2, CP/M 2.2, and an exclusive Eagle menu driven utility package. These units are all "factory new" and are being offered far below their suggested price of \$2495. This is your opportunity to purchase a complete CP/M system for only \$895.

## Return of a Smash Hit Sellout DRAGON \$139



Compatible with most Radio Shack Color Computer software. The world famous Dragon computer is now available in the United States. Manufactured by the Tano Corp under license of the British Broadcasting Company. The Dragon comes complete with 64K Byte of memory, serial modem port along with a Centronics printer interface. This unique micro-computer features Motorola's advanced 6809E microprocessor and comes standard with Microsoft Color Basic, data base manager, and a complete word processing package. The computer outputs color composite video along with R/F video that allows the unit to be used in conjunction with any color television. This is the ideal low cost computer to be used with any dial up information system such as the Source. Western Union's EasyLink or any other time share service.

## TERMINALS

Freedom 100 split screen detachable keyboard  
Clume 102 green phosphor terminal  
Amplex Dialogue 175 amber screen two page, func keys  
Wyse 50 14 green phosphor  
Wyse 300 Eight color display split screen  
Zenith 29 terminal VT52 compatible detach key keyboard  
Televideo 910 Plus touch mode  
Televideo 925 detachable keyboard 22 function keys  
Televideo 950 graphic char split screen 22 func  
Televideo 970 14 green 132 column European

LIB-F100 495.00  
CLM-102 539.00  
APX-A125G 675.00  
APX-D175A 719.00  
WYS-50 595.00  
WYS-300 1159.00  
ZTH-229 765.00  
TVI-910P 575.00  
TVI-925 759.00  
TVI-950 950.00  
TVI-970 1095.00

TOLL FREE ORDER LINE  
(800) 421-5041

TECHNICAL & CALIFORNIA  
(213) 217-0500



# California Digital

17700 Figueroa Street • Carson, California 90248

## C.I.TOH F10 STARWRITER

# \$499

## LETTER QUALITY PRINTER

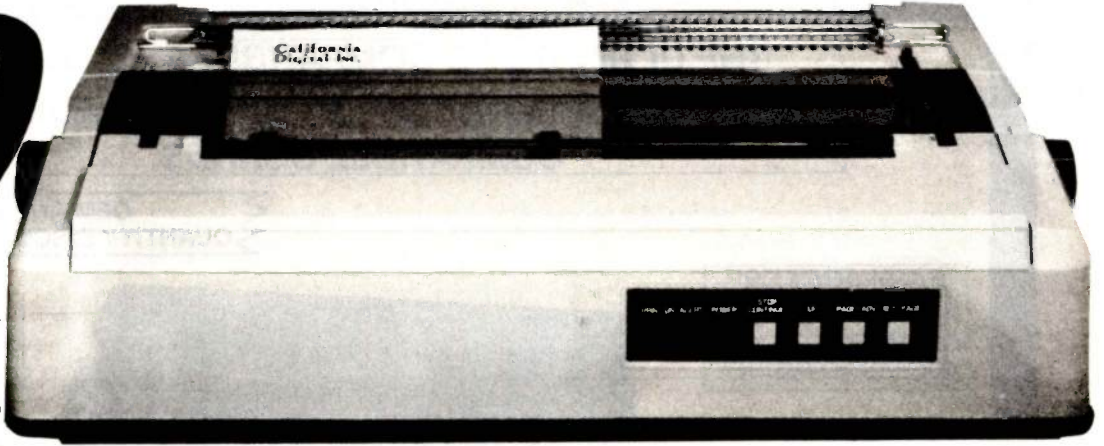

C. Itoh's STARWRITER F-10 is the answer for the perfect daisy wheel printer. The F-10 produces letter quality printing at 40 characters per second. Auto installs with Wordstar and Perfect Writer. Features extensive built-in word processing functions that allow easy adaptability and reduced software complexity. Industry standard Centronics interface provides instant compatibility with all computers equipped with a parallel printer port. The Starwriter F-10 ac-

cepts paper up to 15 inches in width.

These printers were originally priced to sell at over \$1400. Through a special arrangement California Digital has purchase these units from a major computer manufacturer and is offering these printers at a fraction of their original cost.

Options available include tractor feed, buffered memory and an assortment of printer cables for a variety of computers.

## 10 MEGABYTE WINCHESTER SPECIAL

When the March Issue of Byte Magazine went to press California Digital was negotiating for the purchase of several thousand 10 Megabyte Winchester disk drives. The Manufacturer has asked not to advertise their name. Please telephone for details.

# \$319



# \$119

Your Choice

## TEAC 55B 55F 48TPI-96TPI

One Two Ten

Five Inch Double Sided Drives

TEAC FD55B half height	119	115	109
TEAC FD55F 96 TPI, half ht.	119	115	109
CONTROL DATA 9409 PC	169	159	155
SHUGART SA455 Half Height	119	115	109
SHUGART SA465 1/2 Ht. 96TPI	119	115	109
TANDON 100-2 full height	149	145	139
TANDON 101-4 96TPI full ht.	299	289	279
MITSUBISHI 4851 half height	139	135	129
MITSUBISHI 4853 96/TPI 1/2 Ht.	155	149	139
MITSUBISHI 4854 8" elec.	295	285	275
QUME 142 half height	219	205	199

Eight Inch Single Sided Drives

SHUGART 801R	159	159	154
SIEMENS FDD 100-8	119	115	109
TANDON 848E-1 Half Height	369	359	349

Eight Inch Double Sided Drives

SHUGART SA851R	495	485	475
QUME 842 "QUME TRACK 8"	319	319	313
TANDON 848E-2 Half Height	459	447	435
REMEM RFD-4000	219	219	209
MITSUBISHI M2896-63 1/2 Ht.	459	449	409

## MEMORY

4164 DYNAMIC MEMORY 150ns



Quantity 1000

# \$1.35

### DYNAMIC MEMORY

4164 150ns. 64K 128 refresh	1.31	32 +	100 -	
41256 150ns. 256K	2.96	2.25	1.99	
4116 150ns. 16K	9.95	8.50	7.75	
4116 200ns. 16K	1.75	1.65	1.45	
4229 for IBM AT	1.95	1.85	1.45	
DP8409 dynamic controller	12.45	11.50	9.95	
	ICT-8409	39.00	35.00	29.00

### STATIC MEMORY

21L02 200ns. 1K static	1.49	1.29	1.15
21L02 450ns. 1K static	1.29	1.15	.99
2112 450ns. 2K static	2.99	2.85	2.75
2114 300ns. 1K x 4	1.95	1.85	1.75
4044TMS 450ns. 4K x 1	3.49	3.25	2.95
5257 300ns. 4K x 1	2.50	2.25	1.99
8116 P4 200ns. 2K x 8	3.95	3.85	3.70
6116 P3 150ns. 2K x 8	4.55	4.35	4.15

### EPROMS

2708 450ns. 1K x 8	4.95	4.75	4.55
2716 450ns. 2K x 8	4.50	4.25	3.97
2716TMS 450ns. Tri-voltage	7.95	7.65	7.25
2732 450ns. 4K x 8	4.50	3.75	3.55
2764 350ns. 8K x 8	5.95	5.75	6.25
27128 350ns. 16K x 8	7.95	7.35	6.95

## Shugart 604 WINCHESTER



# \$159

These 6.7 Megabyte drives are new units recently released by the Shugart division of Xerox. The Shugart 604 is fully 506 industry compatible. Each drive is tested before shipment and is supplied with a 90 day warranty. SHU-604

### Five Inch Winchester Hard Disk Drives

FUJITSU M2235AS 27 Meg.	999	959
RODIME RO-208 53 Meg.	1589	1493
MAXTOR XT1065 65 Meg.	1995	1965
SHUGART 712 13 Meg. 1/2 Ht	495	465
SHUGART 604 6.7 Meg.	159	149
TANDON 502 10 Meg.	419	395
TANDON 503 19 Meg.	695	675

Shipping: First five pounds \$3.00, each additional pound \$5.00. Foreign orders: 10% shipping, excess will be refunded. California residents add 6 1/2% sales tax. • COD's discouraged. Open accounts extended to state supported educational institutions and companies with a strong "Dun & Bradstreet" rating.





**NEW!!**

# MEGA-CASE™

**NEW!!**

**IDEAL FOR OEM MANUFACTURERS, UNIVERSITIES,  
RESEARCH LABS ETC.**

## THE ULTIMATE PC COMPATIBLE ENCLOSURE

**IDEAL FOR MEGA-BOARD™ XT OR ANY IBM-PC PC-XT  
COMPATIBLE BOARDS**

**OEM AND DEALER  
QUANTITY DISCOUNTS AVAILABLE**

### EASY ACCESS!!

**FLIP-TOP-CASE™  
OPENS FOR EASY  
ACCESS TO INSIDE!!**

**EXCLUSIVE  
FLIP-TOP-CASE™**  
Overcomes Problems  
With PC Case

### Bus Expansion Slot

Allows External  
Access To PC Bus

MOUNTS STANDARD  
POWER SUPPLY

Blank Label Inset  
For Your Company Or  
University Name Here

Mounts Standard  
Half or Full Height  
Floppy Disk  
or Hard Disk Drives

Rugged Heavy Gauge Steel Construction

**ONLY  
\$99<sup>95</sup>  
COMPLETE**

### ADVANCED KEYBOARD

- FEATURES:**
- Horizontal Return Key
  - Caps Lock and Num. Lock Indicators
  - Enter Key for Numeric Keypad



Full PC Compatibility



Fully Assembled and Tested with One Year  
Limited Warranty

**ONLY  
\$149<sup>95</sup>**

**DTC™** DISPLAY  
TELECOMMUNICATIONS  
CORPORATION

4100 SPRING VALLEY ROAD  
SUITE 400  
DALLAS, TX 75234  
(214) 991-1644

**TERMS:** We accept cash, checks, money orders, or purchase orders from qualified firms and institutions. Prices and availability subject to change without notice. Shipping and handling charges via UPS ground 50¢/lb. UPS air \$1.00/lb. Minimum charge \$3.00

# MEGA-BOARD™-XT

**#1 CHOICE OF MAJOR OEM MANUFACTURERS, UNIVERSITIES, RESEARCH LABS ETC. A THOROUGHLY FIELD PROVEN DESIGN. HIGH VOLUME PRODUCTION ENGINEERED.**

- **FULL IBM PC-XT\* COMPATIBILITY!**
- **FULL MEGA-BYTE RAM CAPACITY ON MOTHERBOARD!**

**THOUSANDS SOLD WORLD WIDE!**

**DEALERS AND OEM MANUFACTURERS QUANTITY DISCOUNTS AVAILABLE**

**Standard Keyboard Interface**  
(Full PC compatible)

**Hardware Reset**  
(Overcomes reset flaw in PC)

**Eight Compatible I/O Interface Connectors**  
(Full PC compatible)  
(compatible with all IBM-PC\* plug-in cards)

**Power Connector**  
(Full IBM\* pinout compatible)

**Special J1 Interface**  
(Allows horizontal mounting of compatible expansion cards for easy bus expansion and custom configuring) (Board has 62 pin gold plated compatible connector)

**8088 Processor**  
(Same as PC)

**8087 Numeric Processor**  
(Same as PC)

**Peripheral Support Circuits**  
(Same as PC)

**Extended ROM Capability**  
(Runs all compatible PC ROMS) (Jumper programmable to accommodate all popular 8K, 16K, 32K and 64K ROM chips and NEW EE ROMS! VPP power pin available for EP ROM burning!) (External VPP voltage required)

**Configuration Switches**  
(Same as PC)

**Speaker/Audio Port**  
(Same as PC)

**Wire Wrap Area**  
To facilitate special custom applications!

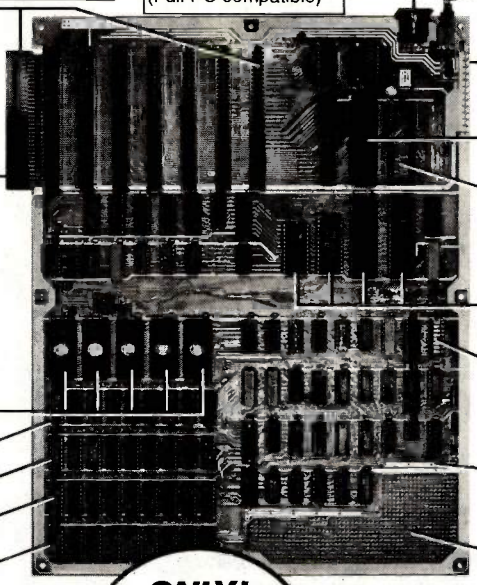

**ONLY!**  
**\$9995**  
**Evaluation Board Kit**

**Mega-Board™ Evaluation Board Kit!**  
(Blank board with full assembly instructions and parts list.)

Includes highest quality PC board with gold plating, silk screen, solder mask

**Board Size** 10.5 inch X 13.5 inch

- MEGA-BOARD™ — XT
  - BARE BOARD KIT ..... \$ 99.95
  - ASSEMBLED AND TESTED SOCKET KIT (LESS IC'S) (FULLY SOCKETED) ..... \$199.95
  - ASSEMBLED AND TESTED — COMPLETE (INCLUDES USERS MANUAL AND MEGA-BIOS ROM) ..... \$499.95
- USERS MANUAL WITH THEORY OF OPERATION, SCHEMATICS, BLOCK DIAGRAM, APPLICATION NOTES ..... \$ 19.95
- MEGA-BIOS™ ROM (2764) FULLY XT COMPATIBLE, MS-DOS, PC DOS ..... \$ 29.95
- HARD TO GET PARTS ..... CALL

**FREE OFFER**

**FREE! Displaytel™ Exclusive.**  
Our Commitment to Microcomputer Education!

**FREE Intel 8088 Data Book** with each Mega-Board™ Order!

**ORDER NOW!!!** Fast, friendly service

**CALL 214-991-1644**

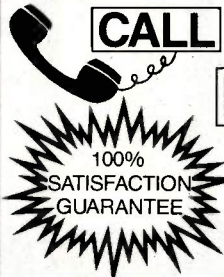

**Immediate shipment!**  
Most instock items shipped same or next day!

10 Day money back guarantee if not completely satisfied!

**DTC™ DISPLAY TELECOMMUNICATIONS CORPORATION**

4100 SPRING VALLEY ROAD  
SUITE 400  
DALLAS, TX 75234  
(214) 991-1644

**TERMS:** We accept cash, checks, money orders, or purchase orders from qualified firms and institutions. Prices and availability subject to change without notice. Shipping and handling charges via UPS ground 50¢/lb. UPS air \$1.00/lb. Minimum charge \$3.00

\*IBM and IBM PC are trademarks of International Business Machines



**4164 64K DYNAMIC 200ns 9/19.95**

**41256 256K DYNAMIC 200ns 10.95**

**STATIC RAMS**

2101	256x4	(450ns)	1.95
5101	256x4	(450ns)(cmos)	3.95
2102-1	1024x4	(450ns)	.89
2102L-4	1024x4	(450ns)(LP)	.99
2102L-2	1024x4	(250ns)(LP)	1.45
2125	1024x1	(45ns)	2.95
2111	256x4	(450ns)	2.49
2111L	256x4	(450ns)(LP)	2.95
2112	256x4	(450ns)	2.99
2114	1024x4	(450ns)	8/9.95
2114-25	1024x4	(250ns)	8/10.95
2114L-4	1024x4	(450ns)(LP)	8/12.95
2114L-3	1024x4	(300ns)	8/13.45
2114L-2	1024x4	(200ns)(LP)	8/13.95
2114L-15	1024x4	(150ns)(LP)	8/19.95
TC5514	1024x4	(650ns)(cmos)	4.95
2141	4096x1	(200ns)	2.95
2147	4096x1	(55ns)	4.95
2148	1024x4	(70ns)	4.95
TMS4044-4	4096x1	(450ns)	3.49
TMS4044-3	4096x1	(300ns)	3.99
TMS4044-2	4096x1	(200ns)	4.49
TMS40144-2	4096x1	(200ns)(LP)	4.95
UPD410	4096x1	(100ns)	3.95
MK4118	1024x8	(250ns)	9.95
TMM2016-200	2048x8	(200ns)	3.25
TMM2016-150	2048x8	(150ns)	3.75
TMM2016-100	2048x8	(100ns)	4.75
HM6116-4	2048x8	(200ns)(cmos)	3.69
HM6116-3	2048x8	(150ns)(cmos)	3.95
HM6116-2	2048x8	(120ns)(cmos)	5.95
HM6116LP-4	2048x8	(200ns)(cmos)(LP)	3.95
HM6116LP-3	2048x8	(150ns)(cmos)(LP)	4.25
HM6116LP-2	2048x8	(120ns)(cmos)(LP)	6.95
TC5516	2048x8	(250ns)(cmos)	9.95
TMS4016	2048x8	(200ns)	6.95
Z-6132	4096x8	(300ns)(Qstart)	34.95
HM6264P-15	8192x8	(150ns)(cmos)	17.95
HM6264LP-15	8192x8	(150ns)(cmos)(LP)	19.95
HM6264LP-12	8192x8	(120ns)(cmos)(LP)	23.95

LP-Low power Qstart=Quasi-Static

**DYNAMIC RAMS**

TMS4027	4096x1	(250ns)	1.99
2107	4096x1	(200ns)	1.95
MMS5280	4096x1	(300ns)	1.95
TMS4050	4096x1	(300ns)	1.95
UPD411	4096x1	(300ns)	1.95
TMS4060	4096x1	(300ns)	1.95
MK4108	8192x1	(200ns)	.49
MMS298	8192x1	(250ns)	.49
4116-300	16384x1	(300ns)	8/6.95
4116-250	16384x1	(250ns)	8/6.95
4116-200	16384x1	(200ns)	8/8.95
4116-150	16384x1	(150ns)	8/10.95
4116-120	16384x1	(120ns)	8/12.95
2118	16384x1	(150ns)(5v)	4.95
MK4332	32768x1	(200ns)	9.95
4164-200	65536x1	(200ns)(5v)	9/19.95
4164-150	65536x1	(150ns)(5v)	9/21.95
4164-120	65536x1	(120ns)(5v)	8.95
MCM6665	65536x1	(200ns)(5v)	4.95
TMS4164-20	65536x1	(200ns)(5v)	4.25
TMS4164-15	65536x1	(150ns)(5v)	4.95
4164-REFRESH	65536x1	(150ns)(5v)(REFRESH)	8.95
TMS4416-20	16384x4	(200ns)(5v)	8.95
TMS4416-15	16384x4	(150ns)(5v)	9.95
41256-200	262144x1	(200ns)(5v)	10.95
41256-150	262144x1	(150ns)(5v)	12.95

5v=Single 5 Volt Supply REFRESH=Pin 1 Refresh

**EPROMS**

1702	256x8	(1us)	4.50
2708	1024x8	(450ns)	3.95
2758	1024x8	(450ns)(5V)	5.95
2716-6	2048x8	(650ns)	2.95
2716	2048x8	(450ns)(5V)	3.95
2716-1	2048x8	(350ns)(5V)	4.95
TMS2516	2048x8	(450ns)(5V)	4.95
TMS2716	2048x8	(450ns)	7.95
TMS2532	4096x8	(450ns)(5V)	4.95
2732	4096x8	(450ns)(5V)	4.25
2732A-4	4096x8	(450ns)(5V)(21V PGM)	4.95
2732A-35	4096x8	(350ns)(5V)(21V PGM)	4.95
2732A	4096x8	(250ns)(5V)(21V PGM)	6.95
2732A-2	4096x8	(200ns)(5V)(21V PGM)	10.95
2764	8192x8	(450ns)(5V)	4.95
2764-250	8192x8	(250ns)(5V)	5.25
2764-200	8192x8	(200ns)(5V)	8.95
TMS2564	8192x8	(450ns)(5V)	10.95
MCM68764	8192x8	(450ns)(5V)(24 pin)	24.95
MCM68766	8192x8	(350ns)(5V)(24 pin)	42.95
27128-45	16384x8	(450ns)(5V)	12.75
27128-30	16384x8	(300ns)(5V)	13.50
27128	16384x8	(250ns)(5V)	13.95
27256	32768x8	(250ns)(5V)	29.95

5V=Single 5 Volt Supply 21V PGM=Program at 21 Volts

**CRYSTALS**

32.768 KHz	1.95
1.0 MHz	3.95
1.8432	3.95
2.0	2.95
2.097152	2.95
2.4576	2.95
3.2768	2.95
3.579545	2.95
4.0	2.95
4.032	2.95
5.0	2.95
5.0688	2.95
5.185	2.95
5.7143	2.95
6.0	2.95
6.144	2.95
5.185	2.95
6.5536	2.95
8.0	2.95
10.0	2.95
10.738635	2.95
14.31818	2.95
15.0	2.95
16.0	2.95
17.430	2.95
18.0	2.95
18.432	2.95
20.0	2.95
22.1184	2.95
24.0	2.95
32.0	2.95

**CRYSTAL OSCILLATORS**

1.0MHz	7.95	8.0	7.95
1.8432	7.95	10.0	7.95
2.0	7.95	12.0	7.95
2.4576	7.95	15.0	7.95
2.5	7.95	16.0	7.95
4.0	7.95	18.432	7.95
5.0688	7.95	20.0	7.95
6.0	7.95	24.0	7.95
6.144	7.95		



**74LS00**

74LS00	.24	74LS189	8.95
74LS01	.25	74LS190	8.95
74LS02	.25	74LS191	8.95
74LS03	.25	74LS192	.79
74LS04	.24	74LS193	.79
74LS05	.25	74LS194	.69
74LS08	.28	74LS195	.69
74LS09	.29	74LS196	.79
74LS10	.25	74LS197	.79
74LS11	.35	74LS221	.89
74LS12	.35	74LS240	.95
74LS13	.45	74LS241	.95
74LS14	.59	74LS242	1.39
74LS15	.35	74LS243	.99
74LS20	.25	74LS244	1.29
74LS21	.29	74LS245	1.49
74LS22	.25	74LS247	.75
74LS26	.29	74LS248	.99
74LS27	.29	74LS249	.99
74LS28	.35	74LS251	.59
74LS30	.25	74LS253	.59
74LS32	.29	74LS257	.59
74LS33	.55	74LS258	.59
74LS37	.55	74LS259	2.75
74LS38	.35	74LS260	.59
74LS40	.25	74LS261	2.25
74LS42	.49	74LS266	.55
74LS47	.75	74LS273	1.49
74LS48	.75	74LS274	1.39
74LS49	.75	74LS279	.49
74LS51	.25	74LS280	1.98
74LS54	.29	74LS283	.69
74LS55	.29	74LS290	.89
74LS56	1.25	74LS293	.99
74LS57	.39	74LS295	.99
74LS74	.35	74LS298	.89
74LS75	.39	74LS299	1.75
74LS76	.39	74LS322	5.95
74LS78	.49	74LS323	3.50
74LS83	.69	74LS324	1.75
74LS85	.69	74LS348	2.50
74LS86	.39	74LS352	1.29
74LS90	.55	74LS353	1.29
74LS91	.89	74LS363	1.35
74LS92	.55	74LS364	1.95
74LS93	.55	74LS365	4.49
74LS95	.75	74LS366	.49
74LS96	.89	74LS367	.45
74LS107	.39	74LS368	.45
74LS109	.39	74LS373	1.39
74LS112	.39	74LS374	1.39
74LS113	.39	74LS375	.95
74LS114	.39	74LS377	1.39
74LS122	.45	74LS378	1.18
74LS123	.79	74LS379	1.35
74LS124	2.90	74LS385	3.99
74LS125	.49	74LS386	.45
74LS126	.49	74LS390	1.19
74LS132	.59	74LS393	1.19
74LS133	.59	74LS395	1.95
74LS136	.39	74LS396	1.89
UPD765	19.95	74LS417	1.49
MB8878	29.95	74LS138	5.55
MB8877	34.95	74LS139	5.55
1691	7.95	74LS159	5.55
2143	7.95	74LS154	1.20
		74LS147	2.49
		74LS148	1.35
		74LS150	1.95
		74LS153	5.55
		74LS154	1.90
		74LS155	.69
		74LS156	.69
		74LS157	.65
		74LS158	.59
		74LS160	.69
		74LS161	.65
		74LS162	.69
		74LS163	.65
		74LS164	.69
		74LS165	.95
		74LS166	1.95
		74LS168	1.75
		74LS169	1.75
		74LS170	1.49
		74LS173	.69
		74LS174	.55
		74LS175	.55
		74LS181	2.15

**★★★★HIGH-TECH★★★★**

**μPD765 \$19.95**

**FLOPPY DISK CONTROLLER**

- ★ AS USED IN IBM PC
- ★ SUPPORTS UP TO FOUR 5 1/4" OR 8" DISK DRIVES
- ★ SINGLE OR DOUBLE DENSITY, SINGLE OR DOUBLE SIDED
- ★ DMA OR NON-DMA OPERATION

**★★★★SPOTLIGHT★★★★**

**GENERATORS BIT RATE FUNCTION**

MC14411	11.95
BR194	11.95
4702	12.95
COM5016	16.95
COM8116	10.95
MMS307	10.95

MC4024 3.95  
LM566 1.49  
XR2206 3.75  
8038 3.95

**CRT CONTROLLERS**

6845	12.95
68B45	19.95
6847	11.95
68047	24.95
HD46505SP	15.95
MC1372	6.95
8275	29.95
7220	39.95
CRT6027	19.95
CRT5037	34.95
TMS9918A	39.95
DP8350	49.95

**DISK CONTROLLERS**

1771	15.95
1791	23.95
1793	23.95
1795	23.95
1797	23.95
2791	39.95
2793	39.95
2795	39.95
2797	39.95
6843	34.95
8272	19.95
UPD765	19.95
MB8878	29.95
MB8877	34.95
1691	7.95
2143	7.95

**KEYBOARD CHIPS**

AY5-2376	11.95
AY5-3600 STD	11.95
AY5-3600 PRO	11.95

**CLOCK CIRCUITS**

MMS5314	4.95
MMS5369	1.95
MMS5369-EST	1.95
MMS5375	4.95
MMS58167	8.95
MMS58174	11.95
MMS5832	3.95

**Z-80 2.5 MHz**

Z80-CPU	2.49
Z80-CTC	2.95
Z80-DART	7.95
Z80-DMA	8.95
Z80-PIO	2.95
Z80-SIO/0	9.95
Z80-SIO/1	9.95
Z80-SIO/2	10.95
Z80-SIO/9	9.95

**6500 1.0 MHz**

6502	4.95
65C02(CMOS)	12.95
6504	6.95
6505	8.95
6507	3.95
6520	2.95
6522	5.49
6532	9.95
6545	9.95
6551	9.95

**6800 68000-8 39.95**

6800	2.95
6802	7.95
6803	19.95
6808	13.90
6809	8.95
6809E	8.95
6810	2.95
6820	4.35
6821	2.95
6828	14.95
6840	12.95
6843	34.95
6844	25.95
6845	12.95
6847	11.95
6850	3.25
6852	5.75
6860	7.95
6875	6.95
6880	2.25
6883	22.95
68047	24.95
68488	19.95

**8000 8031 29.95**

8035	5.95
8039	8.95
INS-8060	17.



# HM6264P-15 8Kx8 STATIC 150ns 17.95 SSI263 SPEECH SYNTHESIZER 39.95

## 74S00

74S00	.32	74S135	.89	74S244	2.20
74S02	.35	74S138	.85	74S251	.95
74S03	.35	74S139	.85	74S253	.95
74S04	.35	74S140	.55	74S257	.95
74S05	.35	74S151	.95	74S258	.95
74S08	.35	74S153	.95	74S260	.79
74S09	.40	74S157	.95	74S273	1.30
74S10	.35	74S158	.95	74S274	19.95
74S11	.35	74S161	1.95	74S275	19.95
74S15	.35	74S162	1.95	74S280	1.95
74S20	.35	74S163	1.95	74S283	3.29
74S22	.35	74S168	3.95	74S287	1.90
74S30	.35	74S169	3.95	74S288	1.90
74S32	.40	74S174	.95	74S289	6.98
74S37	.88	74S175	.95	74S299	7.35
74S38	.85	74S180	11.95	74S301	6.95
74S40	.35	74S181	3.95	74S373	2.45
74S51	.35	74S182	2.95	74S374	2.45
74S54	.40	74S185	16.95	74S381	7.95
74S65	.40	74S188	1.95	74S387	1.95
74S74	.50	74S189	6.95	74S399	2.95
74S85	1.99	74S194	1.49	74S412	2.98
74S86	.50	74S195	1.49	74S420	6.95
74S112	.50	74S196	1.49	74S471	4.95
74S113	.50	74S197	1.49	74S472	4.95
74S114	.55	74S201	6.95	74S474	4.95
74S124	2.75	74S225	3.95	74S570	2.95
74S132	1.24	74S226	3.95	74S571	2.95
74S133	.45	74S269	3.95	74S573	3.95
74S134	.50	74S241	2.20	87S181	16.25
				87S185	16.95

## 7400

7400	.19	7483	.50	74172	5.95
7401	.19	7485	.59	74173	.75
7402	.19	7486	.35	74174	.89
7403	.19	7489	2.15	74175	.89
7404	.19	7490	.35	74176	.89
7405	.25	7491	.40	74177	.75
7406	.29	7492	.50	74178	1.15
7407	.29	7493	.35	74179	1.75
7408	.24	7494	.65	74180	.75
7409	.19	7495	.85	74181	2.25
7410	.19	7496	.70	74182	.75
7411	.25	7497	2.75	74184	2.00
7412	.30	74100	1.75	74185	2.00
7413	.35	74105	1.74	74189	2.99
7414	.49	74110	.30	74190	1.15
7416	.25	74109	.45	74191	1.15
7417	.25	74110	.45	74192	.79
7420	.19	74111	.55	74193	.79
7421	.35	74116	1.55	74194	.85
7422	.35	74120	1.20	74195	.85
7423	.29	74121	.29	74196	.79
7425	.29	74122	.45	74197	.75
7426	.29	74123	.49	74198	1.35
7427	.29	74125	.45	74199	1.35
7428	.45	74126	.45	74221	1.35
7430	.19	74128	.55	74245	1.35
7432	.29	74132	.45	74247	1.25
7433	.45	74136	.50	74248	1.85
7437	.29	74141	.65	74249	1.95
7438	.29	74142	2.95	74251	.75
7439	.29	74143	4.95	74252	2.25
7440	.19	74144	2.95	74265	1.95
7442	.49	74145	.60	74273	1.95
7443	.65	74147	1.75	74276	1.25
7444	.69	74148	1.20	74278	3.11
7445	.69	74150	1.35	74279	.75
7446	.69	74149	.65	74283	2.00
7447	.69	74152	.65	74284	3.75
7448	.69	74153	.55	74285	3.75
7450	.19	74154	1.25	74290	.95
7451	.23	74155	.75	74293	.75
7453	.23	74157	.85	74295	.85
7454	.23	74157	.55	74351	2.25
7460	.23	74159	1.65	74355	.65
7470	.35	74160	.85	74366	.85
7472	.29	74161	.69	74367	.65
7473	.34	74162	.65	74368	.65
7474	.33	74163	.69	74376	2.20
7475	.45	74164	.85	74390	1.75
7476	.35	74165	.85	74393	1.35
7480	.59	74166	1.00	74425	3.15
7481	1.10	74167	2.96	74426	.85
7482	.95	74170	1.65	74490	2.55

## CMOS

4000	.29	4531	.95
4001	.25	4532	1.95
4002	.25	4536	1.95
4006	.89	4539	1.95
4007	.29	4541	2.64
4008	.95	4543	1.19
4009	.39	4553	5.79
4010	.45	4555	.95
4011	.25	4556	.95
4012	.25	4558	2.45
4013	.38	4560	4.25
4014	.79	4569	3.49
4015	.39	4571	3.95
4016	.39	4582	1.95
4017	.69	4584	.75
4018	.79	4585	.75
4019	.39	45151	12.95
4020	.75	4702	12.95
4021	.79	4724	1.50
4022	.79	74000	.35
4023	.29	74002	.35
4024	.65	74004	.35
4025	.29	74008	.35
4026	1.65	74011	.35
4027	.45	74014	.59
4028	.69	74020	.35
4029	.79	74030	.35
4030	.39	74032	.39
4034	1.95	74042	1.29
4035	.85	74048	1.99
4040	.75	74073	.65
4041	.75	74074	.65
4042	.69	74076	.80
4043	.85	74083	1.95
4044	.79	74084	1.95
4046	.85	74086	.39
4047	.95	74089	4.50
4048	.69	74090	1.19
4049	.35	74093	1.75
4050	.35	74099	.35
4051	.79	74100	5.75
4052	1.99	74151	2.25
4053	.79	74154	3.25
4060	.89	74157	1.75
4066	.39	74160	1.19
4068	.85	74161	1.19
4069	.29	74162	1.19
4070	.35	74163	1.19
4071	.29	74164	1.39
4072	.29	74165	2.00
4073	.29	74167	.29
4075	.29	74174	1.19
4076	.79	74175	1.19
4077	.59	74192	1.49
4078	.29	74193	1.49
4081	.29	74195	3.39
4082	.29	74200	5.75
4085	.95	74221	1.75
4086	.95	74224	2.25
4093	.49	74233	2.45
4094	2.99	74234	2.45
4098	2.45	74235	2.45
4099	1.95	74292	.85
14409	12.95	74C903	.85
14410	12.95	74C905	10.95
14411	11.95	74C906	.95
14412	12.95	74C907	1.00
14413	7.95	74C908	1.00
14433	14.95	74C909	2.75
14490	4.95	74C910	9.95
4502	.95	74C911	8.95
4503	.65	74C912	8.95
4507	1.25	74C914	1.95
4508	1.95	74C915	1.19
4510	.85	74C918	2.75
4511	.85	74C920	17.95
4512	.85	74C921	15.95
4514	1.25	74C922	4.49
4515	1.79	74C923	4.95
4516	1.55	74C925	5.95
4518	.89	74C926	7.95
4519	.39	74C927	9.95
4520	.79	74C928	7.95
4521	4.99	74C939	19.95
4522	1.25	74C930	4.95
4526	1.25	80C95	.85
4527	1.95	80C96	.95
4528	1.19	80C97	.85
4529	2.95	80C98	1.20

## HIGH SPEED CMOS

A new family of high speed CMOS logic featuring the speed of low power Schottky (8ns typical gate propagation delay), combined with the advantages of CMOS: very low power consumption, superior noise immunity, and improved output drive.

### 74HC00

74HC: Operate at CMOS logic levels and are ideal for new, all-CMOS designs.

74HC00	.59	74HC175	.99
74HC02	1.25	74HC193	1.25
74HC04	.59	74HC194	1.04
74HC08	.59	74HC195	1.09
74HC10	.59	74HC238	1.35
74HC11	.59	74HC240	1.89
74HC14	.79	74HC241	1.89
74HC20	.59	74HC242	1.89
74HC27	.59	74HC243	1.89
74HC30	.59	74HC244	1.89
74HC32	.69	74HC245	1.89
74HC51	.89	74HC251	.89
74HC74	.75	74HC257	.85
74HC85	.85	74HC259	1.39
74HC85	1.35	74HC273	1.89
74HC86	.69	74HC299	4.99
74HC93	1.19	74HC367	.99
74HC125	1.19	74HC373	2.29
74HC132	1.19	74HC374	2.29
74HC138	.99	74HC393	1.39
74HC139	.99	74HC4017	1.99
74HC151	.99	74HC4020	1.39
74HC153	.89	74HC4024	1.59
74HC154	2.49	74HC4040	1.39
74HC157	.89	74HC4045	.89
74HC161	1.15	74HC4050	.89
74HC164	1.25	74HC4060	1.29
74HC166	2.95	74HC4511	2.39
74HC174	.99	74HC4538	2.29

### 74HCT00

74HCT: Direct, drop-in replacements for LS TTL and can be intermixed with 74LS in the same circuit.

74HCT00	.69	74HCT175	1.09
74HCT02	.69	74HCT193	1.39
74HCT04	.69	74HCT194	1.19
74HCT08	.69	74HCT195	1.39
74HCT10	.69	74HCT238	1.49
74HCT11	.69	74HCT240	2.19
74HCT14	.89	74HCT241	2.19
74HCT20	.69	74HCT242	2.19
74HCT30	.69	74HCT243	2.19
74HCT32	.69	74HCT244	2.19
74HCT38	.69	74HCT245	2.19
74HCT51	.89	74HCT251	1.09
74HCT74	.85	74HCT257	.99
74HCT85	.95	74HCT259	1.59
74HCT85	1.49	74HCT273	2.09
74HCT86	.79	74HCT299	5.25
74HCT93	1.29	74HCT367	1.09
74HCT125	1.29	74HCT373	2.49
74HCT132	1.29	74HCT374	2.49
74HCT138	1.15	74HCT393	1.59
74HCT139	1.15	74HCT4017	2.19
74HCT151	1.05	74HCT4020	1.59
74HCT153	1.05	74HCT4024	1.79
74HCT154	2.99	74HCT4040	1.59
74HCT157	.99	74HCT4045	.99
74HCT161	1.29	74HCT4050	.99
74HCT164	1.39	74HCT4060	1.49
74HCT166	3.05	74HCT4511	2.69
74HCT174	1.09	74HCT4538	2.59

## VOLTAGE REGULATORS

### TO-220 CASE PACKAGE

7805T	.75	7905T	.85
7808T	.75	7908T	.85
7812T	.75	7912T	.85
7815T	.75	7915T	.85
7824T	.75	7924T	.85

### TO-3 CASE PACKAGE

7805K	1.39	7905K	1.49
7812K	1.39	7912K	1.49
7815K	1.39	7915K	1.49
7824K	1.39	7924K	1.49



# DB25S RS232 FEMALE SOLDER CUP 2.25

# DB25P RS232 MALE SOLDER CUP 1.90

## BARGAIN HUNTERS CORNER DYNAMIC RAMS

41256	256K	200ns	\$10.95
4164	64K	200ns	9/\$19.95

## STATIC RAMS

HM6264	8Kx8	180ns	CMOS	\$17.95
TMM2016	2Kx8	200ns		\$3.25
HM6116	4Kx8	300ns	CMOS	\$3.69

## EPROMS

27128	16Kx8	250ns	\$13.95
2764	8Kx8	450ns	\$4.95
2732	4Kx8	450ns	\$4.25

## MATH CO-PROCESSOR CHIPS

8087-3	INTEL	\$129.00
8087-6	INTEL	\$119.00

## SPECIALS ENDS 4/30/85

## HARD TO FIND "SNAPABLE" HEADERS

Can easily be snapped apart to make any size header, all with .1" centers

1x40	STRAIGHT LEAD	1.99
1x40	RIGHT ANGLE	1.49
2x40	STRAIGHT LEAD	2.49
2x40	RIGHT ANGLE	2.99

## SHORTING BLOCKS

SPACED AT .1" CENTERS  
IDEAL FOR DISK DRIVES  
OR ANY .1" HEADER

5/1.00

## DIP SWITCHES

4 POSITION	.85
5 POSITION	.90
6 POSITION	.90
7 POSITION	.95
8 POSITION	.95
10 POSITION	1.29

## 36 PIN CENTRONICS

IDCN36	RIBBON CABLE MALE	8.95
IDCN36/F	RIBBON CABLE FEMALE	8.95
CEN36	SOLDER CUP MALE	7.95

## RF MODULATOR (ASTEC UM1082)

QUANTITIES LIMITED

- \* PRESET TO CHANNEL 3
- \* USE TO BUILD TV-COMPUTER INTERFACE
- \* +5 VOLT OPERATION

\$6.95

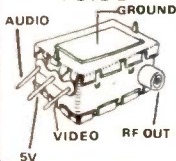

## EMI FILTER

MAJOR MANUFACTURER  
LOW COST  
FITS LC-HP BELOW

\$4.95

## LINE CORDS

LC-2	2 CONDUCTOR	6 ft	.39
LC-3	3 CONDUCTOR	6 ft	.99
LC-HP	3 CONDUCTOR WITH STANDARD FEMALE SOCKET	6 ft	1.49
LC-CIR	CIGARETTE LIGHTER PLUG WITH 6 ft COILED CORD		2.95

## MUFFIN FANS

4.68" SQUARE	14.95
3" SQUARE	14.95

## RESISTORS

1/4 WATT 5% CARBON FILM  
ALL STANDARD VALUES  
FROM 1 OHM TO 10 MEG OHM

50 PIECES SAME VALUE	.025
100 PIECES SAME VALUE	.02
1000 PIECES SAME VALUE	.015

## BYPASS CAPS

.01 µf DISC	100/\$6.00
.01 µf MONOLITHIC	100/\$12.00
.1 µf DISC	100/\$8.00
.1 µf MONOLITHIC	100/\$15.00

## DIODES

1N751	5.1 VOLT ZENER	.25
1N759	12.0 VOLT ZENER	.25
1N4148	(1N914) SWITCHING	25/1.00
1N4001	50PIV 1A	12/1.00
1N4004	400PIV RECTIFIER	10/1.00
1N5402	200PIV 3A	.25
KBPO4	200PIV 1.5A BRIDGE	.45
MDA801	50PIV 12A BRIDGE	1.39
MDA980-1	50PIV 12A BRIDGE	1.95
MDA980-2	100PIV 12A BRIDGE	2.25
VM48	DIP-BRIDGE	.35

## CAPACITORS TANTALUM

1.0 µf	15V .40	.47 µf	35V .50
6.8	15V .70	1.0	35V .45
10	15V .80	2.2	35V .65
22	15V 1.35	4.7	35V .85
.22	35V .40	10	35V 1.00

## DISC

10 µf	50V .05	560	50V .05
22	50V .05	680	50V .05
25	50V .05	820	50V .05
27	50V .05	.001 µf	50V .05
33	50V .05	.0015	50V .05
47	50V .05	.0022	50V .05
56	50V .05	.005	50V .05
68	50V .05	.01	50V .07
82	50V .05	.02	50V .07
100	50V .05	.05	50V .07
220	50V .05	.1	12V .10

## MONOLITHIC

.01 µf	50V .14	.1 µf	50V .18
.047 µf	50V .15	.47 µf	50V .25

## ELECTROLYTIC

RADIAL		AXIAL	
1 µf	25V .14	1 µf	50V .14
2.2	35V .15	4.7	16V .14
4.7	50V .15	10	16V .14
10	50V .15	10	50V .16
47	35V .18	22	16V .14
100	16V .18	47	50V .20
220	35V .20	100	15V .20
470	25V .30	100	35V .25
2200	16V .60	220	25V .30
		330	16V .40
		500	16V .42
		1000	16V .60
		2200	16V .70
		6000	16V .85

## COMPUTER GRADE

44,000 µf	30V 3.95		
-----------	----------	--	--

## LED DISPLAYS

HP5082-7760	CC	4.3"	1.29
MAN-72	CA	.3"	.99
MAN-74	CC	.3"	.99
FND-357(359)	CC	.375"	1.25
FND-500(503)	CC	.5"	1.49
FND-507(510)	CA	.5"	1.49
TIL-311 4x7 HEX W/LOGIC		.270"	9.95

## DIP CONNECTORS

DESCRIPTION	ORDER BY	CONTACTS								
		8	14	16	18	20	22	24	28	40
HIGH RELIABILITY TOOLED ST IC SOCKETS	AUGATxxST	.99	.99	.99	1.69	1.89	1.89	1.99	2.49	2.99
HIGH RELIABILITY TOOLED WW IC SOCKETS	AUGATxxWW	1.30	1.80	2.10	2.40	2.50	2.90	3.15	3.70	5.40
COMPONENT CARRIES (DIP HEADERS)	ICCxx	.49	.59	.69	.99	.99	.99	.99	1.09	1.49
RIBBON CABLE DIP PLUGS (IDC)	IDPxx	---	.95	.95	---	---	---	1.75	---	2.95

FOR ORDERING INSTRUCTIONS SEE IDC CONNECTORS BELOW

## D-SUBMINIATURE

DESCRIPTION	ORDER BY	CONTACTS					
		9	15	25	37	50	
SOLDER CUP	MALE	DBxxP	1.19	1.59	1.90	2.85	4.25
	FEMALE	DBxxS	1.50	1.85	2.25	3.90	5.25
RIGHT ANGLE PC SOLDER	MALE	DBxxPR	1.65	2.20	3.00	4.83	---
	FEMALE	DBxxSR	2.18	3.03	3.00	6.19	---
WIRE WRAP	MALE	DBxxPWW	1.69	2.56	3.89	5.60	---
	FEMALE	DBxxSww	2.76	4.27	6.84	9.95	---
IDC RIBBON CABLE	MALE	IDBxxP	2.95	3.90	4.75	6.95	---
	FEMALE	IDBxxS	3.25	4.29	5.25	7.95	---
HOODS	BLACK	HOOD-B	---	---	.93	---	---
	GREY	HOOD	.89	.95	.99	1.09	1.19

## MOUNTING HARDWARE \$1.00

FOR ORDERING INSTRUCTIONS SEE IDC CONNECTORS BELOW



DB37S  
DB37S  
DB25SR

## TEXTTOOL ZERO INSERTION FORCE SOCKETS AND RECEPTACLES



TYPE	CONTACTS				
	14	16	24	28	40
ECONO ZIF	---	4.95	6.75	7.75	9.95
ZIF SOCKET	4.95	4.95	5.95	6.95	9.95
ZIF RECEPTACLE	8.25	8.75	9.75	10.50	12.75

## IDC CONNECTORS

DESCRIPTION	ORDER BY	CONTACTS					
		10	20	26	34	40	50
SOLDER HEADER	IDHxxS	.82	1.29	1.68	2.20	2.58	3.24
RIGHT ANGLE SOLDER HEADER	IDHxxSR	.85	1.35	1.76	2.31	2.72	3.39
WW HEADER	IDHxxW	1.86	2.98	3.84	4.50	5.28	6.83
RIGHT ANGLE WW HEADER	IDHxxWR	2.05	3.28	4.22	4.45	4.80	7.30
RIBBON HEADER SOCKET	IDSxx	.79	.99	1.39	1.59	1.99	2.25
RIBBON HEADER	IDMxx	---	5.50	6.25	7.00	7.50	8.50
RIBBON EDGE CARD	IDExx	1.75	2.25	2.65	2.75	3.80	3.95

ORDERING INSTRUCTIONS: INSERT THE NUMBER OF CONTACTS IN THE POSITION MARKED "xx" OF THE "ORDER BY" PART NUMBER LISTED. EXAMPLE: A 10 PIN RIGHT ANGLE HOLDER STYLE WOULD BE IDH10SR



IDC20W  
IDE50

## RIBBON CABLE

CONTACTS	SINGLE COLOR		COLOR CODED	
	1'	16'	1'	10'
10	.18	1.60	.83	7.30
16	.28	2.50	1.00	8.80
20	.36	3.20	1.25	11.00
25	.45	4.00	1.32	11.60
26	.46	4.10	1.32	11.60
34	.61	5.40	1.65	14.50
40	.72	6.40	1.92	16.80
50	.89	7.50	2.50	22.00

RETAIL STORE - 1256 S. BASCOM AVENUE  
HOURS: M-W-F, 9-5 TU-TH, 9-9 SAT, 10-3

PLEASE USE YOUR CUSTOMER NUMBER WHEN ORDERING

TERMS: Minimum order \$10.00. For shipping and handling include \$2.50 for UPS Ground and \$3.50 for UPS Air. Orders over 1 lb. and foreign orders may require additional shipping charges - please contact our sales department for the amount. CA residents must include 6% sales tax. Bay Area and LA residents include 6 1/2%. All merchandise is warranted for 90 days unless otherwise stated. Prices are subject to change without notice. We are not responsible for typographical errors. We reserve the right to limit quantities and to substitute manufacturer. All merchandise subject to prior sale.

# JDR Microdevices

1224 S. Bascom Avenue, San Jose, CA 95128  
800-538-5000 • 800-662-6279 (CA) • (408) 995-5430  
FAX (408) 275-8415 • Telex 171-110



# IBM PC PROTOTYPE CARD WITH DECODING CIRCUITRY \$29.95

## WIRE WRAP PROTOTYPE CARDS

FR-4 EPOXY GLASS LAMINATE WITH GOLD-PLATED EDGE-CARD FINGERS



IBM-PR2  
**IBM**  
 BOTH CARDS HAVE SILK SCREENED LEGENDS AND INCLUDES MOUNTING BRACKET  
 IBM-PR1 WITH +5V AND GROUND PLANE \$27.95  
 IBM-PR2 AS ABOVE WITH DECODING CIRCUITRY \$29.95

**S-100**

P100-1	BARE - NO FOIL PADS	\$15.15
P100-2	HORIZONTAL BUS	\$21.80
P100-3	VERTICAL BUS	\$21.80
P100-4	SINGLE FOIL PADS PER HOLE	\$22.75

**APPLE**

P500-1	BARE - NO FOIL PADS	\$15.15
P500-3	HORIZONTAL BUS	\$24.75
P500-4	SINGLE FOIL PADS PER HOLE	\$21.80
7060-45	FOR APPLE IIe AUX SLOT	\$30.00

**GENERAL PURPOSE**  
 22/44 PIN EDGE-CARD (156" SPACING)

P441-1	BARE - NO FOIL PADS 4.5" x 6.0"	\$9.45
P441-3	VERTICAL BUS 4.5" x 6.0"	\$13.95
P441-4	SINGLE FOIL PADS 4.5" x 6.0"	\$14.20
P442-1	BARE - NO FOIL PADS 4.5" x 9.0"	\$10.40
P442-3	VERTICAL BUS 4.5" x 9.0"	\$14.20
P442-4	SINGLE FOIL PADS 4.5" x 9.0"	\$13.50

36/72 PIN EDGE-CARD (1" SPACING)

P721-1	BARE - NO FOIL PADS 4.5" x 6.0"	\$9.45
P721-3	VERTICAL BUS 4.5" x 6.0"	\$13.25
P721-4	SINGLE FOIL PADS 4.5" x 6.0"	\$14.20
P722-1	BARE - NO FOIL PADS 4.5" x 9.0"	\$10.40
P722-3	VERTICAL BUS 4.5" x 9.0"	\$14.20
P722-4	SINGLE FOIL PADS 4.5" x 9.0"	\$15.15

**BARE GLASS BOARDS**

P25x45	2.5" x 4.5"	\$2.40
P45x65	4.5" x 6.5"	\$4.70
P45x85	4.5" x 8.5"	\$6.20
P45x170	4.5" x 17.0"	\$11.35
P85x170	8.5" x 17.0"	\$18.95

**EXTENDER CARDS**

IBM	\$45.00
APPLE	\$45.00
MULTIBUS	\$86.00

## WIRE WRAP WIRE PRECUT AND STRIPPED

Note: 1 inch of insulation is stripped on each end. A 3.5" wire has only 1.5" of insulation.

LENGTH (INCHES)	100	500	1000
2.5	1.60	4.70	8.20
3	1.60	4.70	8.20
3.5	1.65	5.00	8.90
4	1.75	5.40	9.60
4.5	1.80	5.75	10.30
5	1.85	6.10	11.00
5.5	1.90	6.50	11.75
6	2.00	6.85	12.50
6.5	2.30	7.80	14.30
7	2.40	8.20	15.05
7.5	2.50	8.55	15.85
8	2.60	8.95	16.60
8.5	2.65	9.30	17.40
9	2.70	9.80	18.15
9.5	2.80	10.00	18.95
10	2.90	10.50	19.70

**PRECUT ASSORTMENT IN ASSORTED COLORS \$27.50**

100ea: 5.5", 6", 6.5", 7"  
 250ea: 2.5", 4.5", 5"  
 500ea: .3", 3.5", 4"

**SPOOLS**

100 feet	\$4.30	250 feet	\$7.25
500 feet	\$13.25	1000 feet	\$21.95

Please specify color:  
 Blue, Black, Yellow or Red

## GE NICKEL-CADMIUM RECHARGABLE BATTERIES

**NI-CAD CHARGER PACKAGE**  
 PRICE INCLUDES CHARGER (WALL PLUG), BATTERIES, & MODULAR BATTERY HOLDER

AAA CELLS	QTY. 2	\$11.71
AA CELLS	QTY. 2	\$11.71
C CELLS	QTY. 2	\$13.21
D CELLS	QTY. 2	\$13.21
9 VOLT	QTY. 1	\$13.21

**BATTERIES ONLY**

AAA CELLS	PKG. 2	\$6.07 pr.
AA CELLS	PKG. 1	\$3.03 ea.
C CELLS	PKG. 1	\$3.78 ea.
D CELLS	PKG. 1	\$3.78 ea.
9 VOLT	PKG. 1	\$7.57 ea.

## DISK DRIVES

**TANDON**

TM 100-1 5 1/4" (FOR IBM) SS/DD	\$139.95
TM 100-2 5 1/4" (FOR IBM) DS/DD	\$159.95

**MPI**

MPI-B52 8 1/4" (FOR IBM) DS/DD	\$109.95
--------------------------------	----------

**TEAC**

FD-55B 5 1/4" HEIGHT DS/DD	\$129.95
FD-55T 5 1/4" HEIGHT DS/QUAD	\$139.95

**SHUGART**

SA 400 5 1/4" (40 TRACK) SS/DD	\$199.95
SA 460 5 1/4" (80 TRACK) DS/QUAD	\$199.95

**8" DISK DRIVES**

FD100-8 BY SIEMENS, SHUGART 801 EQUIV. DS/DD	\$129.00
FD200-8 BY SIEMENS, SHUGART 801 EQUIV. OS/DD	\$180.00

**JFORMAT-7 \$49.95**  
 SUPPORT FOR QUAD DENSITY DRIVES FROM TALL TREE SYSTEMS

TANDON TM100-2

PLEASE INCLUDE SUFFICIENT AMOUNT FOR SHIPPING ON ABOVE ITEMS

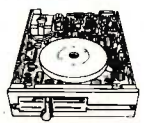

## DISK DRIVE CABINETS

**CABINET #1 \$29.95**

- Fits one full height 5 1/4" disk drive
- Color matches Apple

**CABINET #2 \$79.00**

- Fits one full height 5 1/4" disk drive
- Complete with power supply, switch, line cord, fuse and standard power connector
- Please specify Grey or Tan

**CABINET #3 \$89.95**

- Fits two half height 5 1/4" disk drives
- Complete with power supply, switch, line cord, fuse and standard power connectors

**8" DISK DRIVE CABINETS ALSO AVAILABLE- PLEASE CALL**

PLEASE INCLUDE SUFFICIENT AMOUNT FOR SHIPPING ON ABOVE ITEMS

## SWITCHING POWER SUPPLIES

**PS-IBM \$175.00**

- FOR IBM PC-XT COMPATIBLE
- 130 WATTS
- +5V @ 15A, +12V @ 4.2A
- 5V @ .5A, -12V @ .5A
- ONE YEAR WARRANTY

**PS-A \$49.95**

- USE TO POWER APPLE TYPE SYSTEMS
- +5V @ 4A, +12V @ 2.5A
- 5V @ .5A, -12V @ .5A
- APPLE POWER CONNECTOR

**PS-3 \$39.95**

- AS USED IN APPLE III
- +5V @ 4A, +12V @ 2.5A
- 5V @ .25A, -12V @ .30A
- +15.5" x 4.5" x 2", 884 LBS.

**PS-ASTEC \$19.95**

- CAN POWER TWO 5 1/4" FDDs
- +5V @ 2.5A, +12V @ 2A
- 12V @ .1A
- +5V @ 5A IF +12V IS NOT USED
- 6.3" x 4.0" x 1.9"

## OK INDUSTRIES

**EX-1 IC EXTRACTION TOOL**

- ONE PIECE METAL CONSTRUCTION
- EASILY EXTRACTS 8-24 PIN DEVICES
- LOW COST \$2.19

**EX-2 IC EXTRACTION TOOL**

- EXTRACTS 24-40 PIN DEVICES
- HEAVY DUTY METAL CONSTRUCTION
- GROUND LUGS FOR MOS EXTRACTIONS
- EASY ONE HAND OPERATION \$12.74

**IC INSERTION TOOLS**

INS-1416	for 14-16 pin IC's	\$5.15
MOS-1416	for 14-16 pin IC's	\$10.92
MOS-2428	for 24-28 pin IC's	\$10.92
MOS-40	for 40 pin IC's	\$12.43

MOS series insertion tools have metal construction and include grounding lug for CMOS applications.

**BW-630 WIRE WRAP GUN**

- BATTERY POWERED-USES 2 NI-CAD C CELLS (NOT INCLUDED)
- POSITIVE INDEXING
- ANTI-OVERWRAP DEVICE \$41.55

**WSU-30 WIRE WRAP TOOLS**

- WRAPS, STRIPS, AND UNWRAPS
- WSU-30M WRAPS AN EXTRA TURN OF INSULATION

WSU-30 \$8.84 / WSU-30M \$10.14

**WIRE WRAP TERMINALS**

WWT-1	SLOTTED	25 / \$7.06
WWT-2	SINGLE SIDED	25 / \$4.25
WWT-3	IC SOCKET	25 / \$7.06
WWT-4	DOUBLE SIDED	25 / \$2.80
INS-1	INSERTION TOOL	\$3.64

**WIRE DISPENSER**

- WITH 50' ROLL OF WIRE
- BUILT IN PLUNGER CUTS WIRE
- BUILT IN STRIPPER STRIPES 1"
- REFILLABLE

**WD-30 \$6.50 WD-30TRI \$9.50**

Specify Blue, white, Yellow or Red. With 50' of each.

**SOCKET-WRAP I.D.™**

- SLIPS OVER WIRE WRAP PINS
- IDENTIFIES PIN NUMBERS ON WRAP SIDE OF BOARD
- CAN WRITE ON PLASTIC, SUCH AS IC #

PINS	PART#	PCK. OF	PRICE
8	IDWRAP 08	10	1.95
14	IDWRAP 14	10	1.95
16	IDWRAP 16	10	1.95
18	IDWRAP 18	5	1.95
20	IDWRAP 20	5	1.95
22	IDWRAP 22	5	1.95
24	IDWRAP 24	5	1.95
28	IDWRAP 28	5	1.95
40	IDWRAP 40	5	1.95

PLEASE ORDER BY NUMBER OF PACKAGES (PCK. OF)

## TRANSFORMERS

**FRAME STYLE**

12.6V AC	2 AMP	4.95
12.6V AC CT	2 AMP	5.95
12.6V AC CT	4 AMP	7.95
12.6V AC CT	8 AMP	10.95
25.2V AC CT	2 AMP	7.95

**PLUG CASE STYLE**

12V AC	250ma	3.95
12V AC	500ma	4.95
12V AC	1 AMP	5.95
12V AC	2 AMP	6.95

**DC ADAPTER**

6, 9, 12V DC	SELECTABLE WITH UNIVERSAL ADAPTER	8.95
--------------	-----------------------------------	------

## MICROCOMPUTER HARDWARE HANDBOOK

**FROM ELCOMP \$14.95**

Over 800 pages of manufacturer's data sheets on the most commonly used IC's

- TTL - 74, 74LS & 74F
- CMOS
- Voltage regulators
- Memory - RAM, ROM, EPROM
- CPU's - 6800, 6500, Z80, 8080, 8085 & 8086/8
- MPU Support & Interface, 6800, 6500, Z80, 8200, etc.

VISA

ORDER TOLL FREE  
**800-538-5000**  
**800-662-6279**  
 (CALIFORNIA RESIDENTS)

MasterCard

## 20 MHz DUAL TRACE OSCILLOSCOPE FROM RAMSEY ELECTRONICS

**UNSURPASSED QUALITY AT AN UNBEATABLE PRICE**

- BAND WIDTH- DC: DC TO 20MHz (-3db) AC: 10Hz TO 20MHz (-3db)
- SWEEP TIME- 2 μSEC TO .5 SEC/DIV ON 20 RANGES
- VERT./HORZ. DEFLECTION: 5mV TO 20V/DIV ON 20 RANGES
- COMPLETE MANUAL AND HIGH QUALITY HOOD ON PROBES INCLUDED
- INPUT IMPEDANCE: 1 MEG OHM
- TV VIDEO SYNC FILTER
- X, Y AND Z AXIS OPERATION
- 110/220 VOLT 50/60Hz OPERATION
- COMPONENT TESTER
- LP CONSUMPTION - 19 WATTS
- BUILT IN CALIBRATOR
- AUTOMATIC OR TRIGGERED TIMEBASE

**\$399.95 WITH PROBES**

**FULL ONE YEAR WARRANTY**

## MULTIMETER PEN

**AUTO RANGING, POLARITY & DECIMAL!**

- LARGE 3 1/2" DIGIT DISPLAY
- DATA HOLD SWITCH FREEZES READING
- FAST, AUDIBLE CONTINUITY TEST
- LOW BATTERY INDICATOR
- OVERLOAD PROTECTION
- ONLY 1 1/4" x 6 1/4" x 3/4"
- DC VOLTS .1mV-500V
- AC VOLTS 1mV-500V
- .1 OHM-20 MEG OHMS
- WEIGHS ONLY 2.3 DUNCES
- LOW PARTS COUNT-CUSTOM 80 PIN LSI INSURES RELIABILITY
- INCLUDES MANUAL, BATTERIES, SOFT CASE, 2 PROBE TIPS, AND ALLIGATOR CLIP

**ONLY \$49.95**



**TEAC-FD55B** DS/DD 1/2 HT. **129.95**  
FOR IBM PC

**MPI-B52** DS/DD FULL HT. **109.95**  
FOR IBM PC

**EPROM PROGRAMMER**  
FOR APPLE COMPUTERS

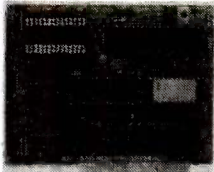

**RP525**  
**\$79.95**



- \* LOW COST!
- \* DUPLICATE OR BURN ANY STANDARD 27xx SERIES EPROM
- \* EASY TO USE MENU-DRIVEN SOFTWARE INCLUDED
- \* MENU SELECTION FOR 2716, 2732, 2732A, 2764 & 27128
- \* HIGH SPEED WRITE ALGORITHM
- \* LED INDICATORS FOR ACTIVITY
- \* NO EXTERNAL POWER SUPPLY REQUIRED

**DISK DRIVES FOR IBM**



**TEAC**  
**FD55B**  
**\$129.95**

**TANDON**  
**TM100-2**  
**\$159.95**

**MPI**  
**MODEL B52**  
**\$109.95**

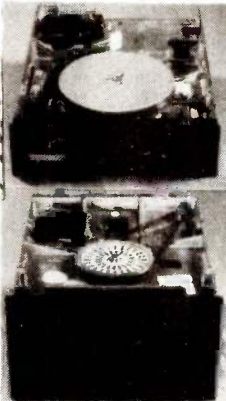

**IBM ACCESSORIES**

- MAXIMIZER** SIGMA MULTIFUNCTION CARD **\$259.95**
- HAYES SMARTMODEM** 1200B FOR IBM **\$419.95**
- PRINTER CABLE** PARALLEL 6' SHIELDED CABLE **\$19.95**
- KRAFT JOYSTICK** **\$39.95**

**DISKETTE FILE**

**\$8.95** IF PURCHASED WITH 50 DISKETTES OR MORE

*\$9.95 IF PURCHASED ALONE*

**HOLDS 70 5 1/4" DISKETTES, WITH ROOM TO SPARE**

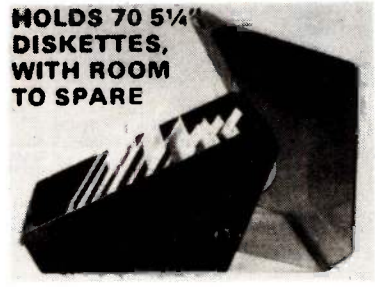

**16K RAM CARD \$39.95**

- BARE PC CARD AND INSTRUCTIONS **\$9.95**
- \* 2 YEAR WARRANTY
- \* EXPAND YOUR 48K APPLE TO 64K
- \* USE IN PLACE OF APPLE LANGUAGE CARD

**DISK DRIVES**

FOR APPLE COMPUTERS



**BAL-525**  
**\$139.95**

- \* 1/2 HEIGHT-ALPS MECHANISM
- \* 100% APPLE COMPATIBLE
- \* FULL 1 YEAR WARRANTY



**BAL-500**  
**\$169.95**

- \* TEAC MECHANISM- DIRECT DRIVE
- \* 100% APPLE COMPATIBLE- 35 TRACK
- \* 40 TRACK WHEN USED WITH OPTIONAL CONTROLLER



**MITAC**  
**AD-1**  
**\$179.95**

- \* FULL HEIGHT SHUGART MECHANISM
- \* DIRECT REPLACEMENT FOR APPLE DISK II

**DISK DRIVE ACCESSORIES**

- DISK CONTROLLER CARD** **\$49.95**
- APPLE IIc ADAPTOR CABLE** **\$19.95**
- NOW FOR APPLE IIc

**BMC MONITOR STAND**

**MODEL PA-900**

TILTS AND SWIVELS TO PROVIDE OPTIMUM VIEWING ANGLE, REDUCES OPERATOR FATIGUE



**FACTORY SPECIAL \$14.95**

**ORDER TOLL FREE**  
**800-538-5000**  
**800-662-6279 (CA)**

**BMC BX-80 PRINTER**

**80 CPS DOT MATRIX PRINTER**

- \* BI-DIRECTIONAL
  - \* SUPERB GRAPHICS
  - \* CENTRONICS INTERFACE
- \$199.95**
- CLOSE-OUT SPECIAL, QUANTITIES LIMITED*

**APPLE ACCESSORIES**

- VIEWMAX-80** **\$159.95**
- VIEWMAX-80e** **\$129.95**
- GRAPHMAX** **\$129.95**
- THUNDERCLOCK** **\$129.95**
- KRAFT JOYSTICK** **\$39.95**
- POWER SUPPLY** **\$49.95**

**NASHUA DISKETTES**

**5 1/4" SOFT SECTOR DS/DD WITH HUB RINGS**

BULK PACKAGED IN FACTORY SEALED BAGS OF 50. INCLUDES DISKETTE SLEEVES AND WRITE PROTECT TABS. IDEAL FOR SCHOOLS, CLUBS, AND USERS GROUPS. THIS IS A SPECIAL PURCHASE, SO QUANTITIES ARE LIMITED. THERE IS A 5 YEAR WARRANTY.

**\$1.39ea. \$1.49ea. \$1.59ea.**  
QTY 250 QTY 100 QTY 50

NASHUA DISKETTES WERE JUDGED TO HAVE THE HIGHEST POLISH AND RECORDED AMPLITUDE OF ANY DISKETTES TESTED. (SEE "COMPARING FLOPPY DISKS", BYTE 9/84)

**VERBATIM DATALIFE DISKETTES**

- SS/DD SOFT SECTOR **\$29.95**
- SS/DD 10 SECTOR HARD **\$29.95**
- DS/DD SOFT SECTOR **\$34.95**

**IBM COMPATIBLE POWER SUPPLIES**

**130 WATT**  
**\$159.95**

**XT COMPATIBLE**

- \* +5V @ 15A, +12 @ 4.2A
- \* -5 @ 5A, -12 @ .5A
- \* UPGRADE YOUR PC, POWERS HARD DISK
- \* POWER CABLES FOR 4 FDDs
- \* ONE YEAR WARRANTY
- \* SWITCH ON SIDE (FITS IBM CASE)



**100 WATT**  
**\$99.95**

- \* SWITCH ON REAR
- \* FOR USE IN OTHER IBM TYPE MACHINES
- \* AVAILABLE IN 100W OR 130W VERSIONS
- \* 90 DAY WARRANTY



**130 WATT MODEL \$129.95**

**JDR Microdevices**

1224 S. Bascom Avenue, San Jose, CA 95128  
800-538-5000 • 800-662-6279 (CA) • (408) 995-5430  
FAX (408) 275-8415 • Telex 171-110

RETAIL STORE - 1256 S. BASCOM AVENUE  
HOURS: M-W-F, 9-5 TU-TH, 9-9 SAT, 10-3

PLEASE USE YOUR CUSTOMER NUMBER WHEN ORDERING

TERMS: Minimum order \$10.00. For shipping and handling include \$2.50 for UPS Ground and \$3.50 for UPS Air. Orders over 1 lb. and foreign orders may require additional shipping charges - please contact our sales department for the amount. CA. residents must include 6% sales tax. Bay Area and LA residents include 6 1/2%. All merchandise is warranted for 90 days unless otherwise stated. Prices are subject to change without notice. We are not responsible for typographical errors. We reserve the right to limit quantities and to substitute manufacturer. All merchandise subject to prior sale.



# U·N·C·L·A·S·S·I·F·I·E·D A·D·S

**WANTED:** Children's Service Society of Wisconsin seeks tax-deductible donation of Apple IIe or II+ for information management. Carole Montemayor, Children's Service Society, 2059 Atwood Ave., Madison, WI 53704. (608) 249-8506.

**WANTED:** Charitable nonprofit organization seeks donation of computers, peripherals, printers, monitors, terminals, disk drives, memory expansion, etc. Certified receipts furnished; will pay reasonable shipping. Holdeman International, POB 329, West Point, MS 39773.

**WANTED:** Donations of any personal computer, peripherals, and supplies to advance work of stuttering self-help organization. Tax-deductible; will pay shipping. Speak Easy Int'l. Foundation, 233 Concord Dr., Paramus, NJ 07652. (201) 262-0895.

**WANTED:** A group of Malaysian students in Fresno would like advice and support from experienced IBM PC users. Hasnul Hashim, Apt. D, 2127 East Shaw Ave., Fresno, CA 93710. (209) 229-1214.

**AVAILABLE:** Free to all MS-DOS, PC-DOS, and Z-DOS users: disk containing 55-page book about techniques for structured programming, plus demo programs. Send disk, mailer, and stamps to Dennis Baer, 25 Miller Rd., Farmingdale, NY 11735. (516) 694-5872.

**WANTED:** Nonprofit antiabortion group needs computer equipment and peripherals for national office. The Pro-Life Brotherhood, 350 South Orchard Dr., Park Forest, IL 60466. (312) 747-0348.

**NEEDED:** Information about Systems Engineering Enterprise (SEE) Corp., their users, technicians or employees. My SEE 6684 System lost IPL PROM information. Last address was in Rockville, MD; telephone disconnected. Miguel Martinez, Puerto Rico 419B, León, Guanajuato, Mexico 37360.

**WANTED:** Implementation of Kevin Weiler's Hidden Surface algorithm ("Hidden Surface Removal Using Polygon Area Sorting," *SIGGRAPH*, August 1977). Ernie Pyle, Apt. 1, Building 38, 2147 Linton Blvd., Delray Beach, FL 33445. (305) 272-1744 or 998-1259.

**WANTED:** College student requests any information on catastrophe theory and/or fractals and their implementation on a computer. Chris Mathews, 416 Redondo N. Litchfield Park, AZ 85340.

**NEEDED:** Information on programs involving concept of "Music of the Spheres." Has anyone composed music using sound analogs of planetary orbits, etc., as themes? Musicological research paper in progress needs references. Tom Shinnick, Apt. 3, 1905 Brunson, Houston, TX 77030.

**FOR SALE:** IMSAI—original, unassembled, mint condition. I. J. Haugh, 3970 North Oakland Ave., Milwaukee, WI 53211. (414) 962-5022. 9 a.m.—5 p.m.

**FOR SALE:** C. Itoh F10-40 printer: \$899; Oume OVT102: \$438; Morrow MP100 printer: \$308; TI 855 with tractor: \$698; Morrow MDT60 video terminal: \$278; Morrow MD2 (new): \$798; Liberty 100: \$318. All near new, original packing. G. S. Schacter, POB 1002, South Gate, CA 90280. (213) 567-8758.

**FOR SALE:** Intel 8087 for IBM ceramic chips: \$175. Steve Rank, 1260 Monument Blvd., Concord, CA 94518.

**FOR SALE:** SD Systems S-100 board set, including SBC 200 Z80 CPU/I/O, Versafloppy II 5- and 8-inch controller, ExpandoRAM II 64K memory fully populated, all manuals: \$500 or best offer. Isaac Davidian, 2329 East Ashlan, Fresno, CA 93726. (209) 227-2005 or 224-9212.

**FOR SALE:** S-100 boards, CompuPro CPU 8085/8088: \$200; CompuPro CPU Z80: \$150; Vector Bitstreamer 3 serial 2 parallel I/O: \$75; two 32K dual-memory boards: \$75. Bob Lankford, 4117 Spruce Hills Dr., Cedar Falls, IA 50613. (319) 277-2424.

**WANTED:** Information or instructions on building a heat laser. I pay all postage and handling. Tom Chrisman, Rt. 3, Box 194, Hamburg, AR 71646.

**NEEDED:** Correspondence with Victor 9000 users, groups, clubs, or newsletters. John Howard, POB 712, North Haven, CT 06473.

**WANTED:** Other HX-20 owners to form a U.S.-based club. James Stensrud, 26 East Superior St., Duluth, MN 55802.

**FOR SALE:** Two 8-inch Oume disk drives in Vista cabinet. DS/DD hardly used. Includes manual, Scotch disks, head-cleaning kit, two cables: \$700.

Ellis King, 6520 Selma #209, Los Angeles, CA 90028. (213) 467-3000, or Dick Myers, (213) 652-4071, 8-9 a.m.

**NEEDED:** Epson QX-10 people interested in sharing information and resolving application problems. Patric Lee Howley, 454 Barcelona Dr., Satsuma, AL 36572.

**FOR SALE:** Z-100 computer, two drives, 192K plus color video RAM, 8-MHz, etc.: \$2195. Also twin Siemens 8-inch drives with power and enclosure: \$200 (need adjustment). George Tucker, 11615 Mississippi, Los Angeles, CA 90025. (213) 473-7691.

**FOR SALE:** Hewlett-Packard equipment: IDS 560G 200-cps, wide-forms printer: \$750; 9130A disk drive (for 86A): \$450; HP41C calculator with statistics, time, HPIL interface, and quad memory modules: \$285; 82161 HPIL tape drive: \$285; both for \$580. Randy Webb, 622 East 11th St., Bloomington, IN 47401. (812) 335-1858 or 339-7661.

**NEEDED:** Dr. Dobbs's *Journal* issues 57, 58, 59, 62, 63, and 64: any reasonable price paid. Also I have spare copies of issues 48, 49, 51, 53, and 55. David Milline, c/o NVR, Front St. W, Bedlington, Northumberland, NE22 5UB, England.

**FOR TRADE:** Our small public-domain users group for Apple II and TRS-80 Model III disk systems is expanding its software database. Send your public-domain software list or disk(s) and we'll return them. Arthur Hamlyn, Willinggate, Newfoundland A0G 4M0, Canada.

**FOR SALE:** Sabtronics LCD digital multimeter (bench type): \$85. Sabtronics functional generator (bench type): \$85. Heathkit 10-4235 35-MHz, dual-trace, delayed-sweep oscilloscope: \$685. All like new. Tom Lee, Apt. 240, 100 North Whisman St., Mountain View, CA 94043. (408) 946-3000 or (415) 969-5734.

**FOR SALE:** BYTE volume 2, numbers 5, 11, 12; volume 3, numbers 1, 2, 3, 4, 5, 6. Like-new condition: \$5 each or \$37.50 for all. *Kilobaud* numbers 1-22, like-new condition: \$90. Numbers 14, 15, 16, 17, like-new condition: \$5 each or \$17.50 for set. J. C. Arquette, 218-B Marshall St., Princeton, NJ 08540. (609) 924-8919.

**FOR SALE:** Radio Shack Model 100, 32K (factory installed), case, AC adapter, GE Computer Data Recorder, modem-phone and parallel-printer (Centronics-type) cables: \$1395 value for \$899. First certified check takes it. M. Neidich, 18 Hillside Lane, Syosset, NY 11791. (516) 921-3603 for UPS collect shipment.

**FOR SALE:** Quay 520 desktop computer. Includes 64K RAM, parallel-printer port, RS-232C serial port, asynchronous communications software, owner-written: \$900 plus shipping. Bill Connor, 6 Schooner's Cove, East Setauket, NY 11733. (516) 231-0333.

**WANTED:** Tomy Tutor-compatible cassette recorder; will pay up to \$150 for new, or patch cord for regular recorder and information on start-up. Bruce Turner, 353 Wisteria, Las Vegas, NV 89107.

**WANTED:** Contact with HP 85/86/87 users for club. Andre Lechat, case postale 3, CH-1510 Moudon, Switzerland.

**NEEDED:** Any information on a Measurement Systems and Controls Inc. 64K dynamic RAM board, Model DMB-6400, Rev. B. Hal Arthurs, Bloomfield Station, Prince Edward Island C0B 1E0, Canada. (902) 882-2746.

**WANTED:** BYTE August 1980 for articles on FORTH. Charlie Hottel, 5900 Kentucky Ave., Forestville, MD 20747. (301) 735-7495.

.....  
**UNCLASSIFIED ADS MUST BE noncommercial, from readers who have computer equipment to buy, sell, or trade on a one-time basis. All requests for donated computer equipment must be from nonprofit organizations. Programs to be exchanged must be written by the individual or be in the public domain. Ads must be typed double-spaced, contain 50 words or less, and include full name and address. This is a free service; ads are printed as space permits. BYTE reserves the right to reject any unclassified ad that does not meet these criteria. When you submit your ad (BYTE, Unclassified Ads, POB 372, Hancock, NH 03449), allow at least four months for it to appear.**

**WANTED:** SYM-I, KIM-I, and accessories. Send specifics, SASE, and price. Brian Jacoby, RR 1, Box 157, Vesta, MN 56292.

**FOR SALE:** Two IBM SS/DD 5¼-inch disk drives, perfect condition: \$100 each, both for \$150, or best offer. A. Neil Hermanson, 2039 Parkdale, Kingwood, TX 77339. (713) 358-9153 after 6 p.m.

**FOR SALE:** Sony Typecorder with serial communications module and microcassette storage unit: \$500. Also, Olivetti model 231 word processor with wafer-tape storage unit and many spin-wheel type elements: \$1500. Lee D. Miller, 932 North Lakeshore Dr., Lincoln, NE 68528. (402) 435-3864.

**FOR SALE:** 8-slot S-100 bus system, includes Z80 B serial and parallel, 64K, Oume DS/DD 8-inch floppy, Ampex 20-megabyte hard disk with Monitor Dynamics controller card, TeleVideo 925 terminal, Daisywriter printer, and more: \$4500 for all, negotiable. Kirk Turner, 22054 DeBerry, Grand Terrace, CA 92324. (714) 783-0636.

**WANTED:** Omron 12SR, Pickett N4ES, Corvus 500. State condition and price in letter. William B. Adams, POB 1467, Springfield, VA 22151.

**FOR SALE:** IBM-compatible with 8088 and Z80 processors: runs PC-DOS, MS-DOS, CP/M-86, CP/M-80; two disk drives; 128K memory; serial port; parallel port; portable with 9-inch green monitor; RGB and composite color outputs: \$1500. Cory Barker, 1715 East 1750 N. Layton, UT 84041. (801) 546-2084.

**FOR SALE:** Onyx C8002 computer with 40-megabyte hard disk, 512K main memory, and peripherals. Wallace Landholm, 320 Superior Ave. #350, Newport Beach, CA 92663. (714) 631-4780.

**NEEDED:** Computer-controlled auto-dial unit that uses a serial RS-232C port. Have Bell 212AR 300/1200-bps modem. Would like circuit diagram and parts list for building, or company address, \$50 or less. Tom Brown, 65 Hillside Ave., Berkeley Heights, NJ 07922.

**NEEDED:** Correspondence with other HP 75 users who want to exchange ideas. Letters received will be copied or digested and sent to others who write, but this is not a newsletter per se. Particularly interested in business and financial applications. Patrick Cully, 77 Labau Ave., Staten Island, NY 10301.

**WANTED:** I need information on starting a BBS. Any help appreciated: tips, public-domain or user-written software for the Apple II, articles, etc. Will pay postage and expenses. Paul Alien, POB 29874, 65th Infantry Station, San Juan, Puerto Rico 00929.

**WANTED:** Will buy used Digicom DR70, Astrion System 30, and/or Epson OX-10, Kaypro 4, or Apple IIc. Also system with dot-matrix and letter-quality printer. Need a user group on the central Oregon coast and astrological software sources. J. Robin-dottir, Venus, POB 2435, Lincoln City, OR 97367. (503) 996-3665.

**FOR SALE:** Quantel Color Frame Grabber; system includes NTSC decoder and encoder. 16-bit CPU, two 8-inch floppy-disk drives, documentation, source code, bit pad, terminal, and 19-inch Tektronix 670 color monitor. Dave Sieg, 7232 Leota Lane, Canoga Park, CA 91304. (818) 883-4853.

**FOR SALE:** Two S-100 boards, 16K dynamic RAM, 32K static RAM, video interface, three parallel and serial ports, 2K PROM, and music boards. Jim Heires, 5104 South 79th Ave., Ralston, NE 68127. (402) 331-6749 or 345-8400.

**FOR SALE:** Texas Instruments Professional computer, desktop model. Almost new, 13-inch hi-res color monitor; 3-plane (8-color) graphics card; 256K; two disk drives; documentation and instructions. \$2900 or best offer. Elizabeth Peterson, 240 North Oak St., Janesville, IA 50647. (319) 987-2286.

**FOR SALE:** Two IBM 5¼-inch 160K disk drives in original cartons. Excellent condition, practically new. Were \$578, asking \$260 or \$140 each. With documentation. E. V. Allegritti, RD 3, Lois Lane, Katonah, NY 10536. (914) 232-4470.

**FOR SALE:** Assorted S-100 boards: SD Systems ExpandoRAM II 64K: \$175; Jade Big Z Z80 CPU: \$50; Z80B CPU: \$175; SSM VB3A 80-character by 50-line video board and 160 by 200 matrix graphics: \$350; CCS 2422 floppy-disk controller: \$250. Dale Barrett, 16544 San Jacinto Ave., Fontana, CA 92335. (714) 822-2511.



# B·O·M·B

## BYTE'S ONGOING MONITOR BOX

ARTICLE#	PAGE	ARTICLE	AUTHOR(S)
1	96	What's Not . . . . .	BYTE staff
2	102	Ciarcia's Circuit Cellar: Build the Home Run Control System. Part I: Introduction . . . . .	Ciarcia
3	113	Coprocessing in Modula-2 . . . . .	Wilson
4	120	A Million-Point Graphics Tablet . . . . .	Hawley
5	126	Communication with Alien Intelligence . . . . .	Minsky
6	143	The Quest to Understand Thinking . . . . .	Schank, Hunter
7	159	The LISP Tutor . . . . .	Anderson, Reiser
8	179	PROUST . . . . .	Johnson, Soloway
9	193	Architectures for AI . . . . .	Deering
10	209	The LISP Revolution . . . . .	Winston
11	223	The Challenge of Open Systems . . . . .	Hewitt
12	245	Vision . . . . .	Ballard, Brown
13	265	Learning in Parallel Networks . . . . .	Hinton
14	277	Connections . . . . .	Feldman
15	286	Reverse Engineering the Brain . . . . .	Stevens
16	303	The Technology of Expert Systems . . . . .	Michaelsen, Michie, Boulanger
17	315	Inside an Expert System . . . . .	Thompson, Thompson
18	338	The ITT XTRA . . . . .	Unger
19	345	Insight—A Knowledge System . . . . .	D'Ambrosio
20	355	Computing at Chaos Manor: Over the Moat . . . . .	Pournelle
21	379	BYTE West Coast: Lasers, Office Publishing, and More . . . . .	Markoff, Robinson
22	389	BYTE U.K.: New Database Ideas . . . . .	Pountain
23	401	BYTE Japan: The Fifth Generation in Japan . . . . .	Raike

### LINEAR RELIABILITY

Readers voted most favorably for "Understanding Linear Power Supplies," Steve Ciarcia's Circuit Cellar project appearing in January. In second place is the second part of the interview with Steve Wozniak: "The Apple Story: More History and the Apple III," conducted by BYTE senior technical editor Gregg Williams and Rob Moore. Rob wins \$100. Jerry Pournelle's whirlwind tour in "The Fast Lane" of Computing at Chaos Manor wound up winning third place. "A Glimpse into Future Television" placed fourth in the survey; Joseph Nadan earns \$50. And fifth mention goes to an article written about a tool for thinking: "The Visual Mind and the Macintosh" by Bill Benzon.

### BYTE ADVERTISING SALES STAFF:

**J. Peter Huestis, Advertising Sales Manager, 70 Main Street, Peterborough, NH 03458, tel. (603) 924-9281**

#### NEW ENGLAND

ME, NH, VT, MA, RI  
Paul McPherson Jr. (617) 262-1160  
McGraw-Hill Publications  
575 Boylston Street  
Boston, MA 02116

#### ATLANTIC

NY, NJ, CT, RI (NORTH)  
Dick McGurk (212) 512-3588  
Leah Goldman (212) 512-2096  
McGraw-Hill Publications  
1221 Avenue of the Americas—  
39th Floor  
New York, NY 10020

#### EAST

PA (EAST), NJ (SOUTH),  
MD, VA, W VA, DE, D.C.  
Daniel Ferro (215) 496-3833  
McGraw-Hill Publications  
Three Parkway  
Philadelphia, PA 19102

#### SOUTHEAST

NC, SC, GA, FL, AL, TN  
Maggie M. Dorvee (404) 252-0626  
McGraw-Hill Publications  
4170 Ashford-Dunwoody Road—  
Suite 420  
Atlanta, GA 30319

#### MIDWEST

IL, MO, KS, IA, ND, SD, MN, WI, NB, IN  
Bob Denmead (312) 751-3740  
McGraw-Hill Publications  
Blair Building  
645 North Michigan Ave.  
Chicago, IL 60611

#### GREAT LAKES, OHIO REGION

MI, OH, PA (ALLEGHENY), KY,  
EASTERN CANADA  
Mike Kisseberth (313) 352-9760  
McGraw-Hill Publications  
4000 Town Center—Suite 770  
Southfield, MI 48075

#### SOUTHWEST, ROCKY MOUNTAIN

UT, CO, WY, OK, TX, AR, MS, LA  
Dennis Riley (214) 458-2400  
McGraw-Hill Publications  
Prestonwood Tower—Suite 907  
5151 Beltline  
Dallas, TX 75240

#### SOUTH PACIFIC

SOUTHERN CA, AZ, NM, LAS VEGAS  
Jack Anderson (714) 557-6292  
McGraw-Hill Publications  
3001 Red Hill Ave.  
Building #1—Suite 222  
Costa Mesa, CA 92626

Karen Niles (213) 480-5243, 487-1160

McGraw-Hill Publications  
3333 Wilshire Boulevard #407  
Los Angeles, CA 90010

#### NORTH PACIFIC

HI, WA, OR, ID, MT, NORTHERN CA,  
NV (except LAS VEGAS), W CANADA  
David Iern (415) 362-4600  
McGraw-Hill Publications  
425 Battery Street  
San Francisco, CA 94111

Bill McAfee (415) 964-0624

McGraw-Hill Publications  
1000 Elwell Court—Suite 225  
Palo Alto, CA 94303

#### WEST COAST SURPLUS

#### AND RETAIL ACCOUNTS

Tom Harvey (805) 964-8577  
3463 State Street—Suite 256  
Santa Barbara, CA 93105

#### Post Card Mailings

National  
Bradley Browne (603) 924-6166  
BYTE Publications  
70 Main Street  
Peterborough, NH 03458

### International Advertising Sales Representatives:

Mr. Hans Csokor  
Publimedia  
Reisnerstrasse 61  
A-1037 Vienna, Austria  
222 75 76 84

Mrs. Gurit Gepner  
McGraw-Hill Publishing Co.  
PO Box 2156  
Bat Yam, 59121 Israel  
3 866 561 321 39

Mr. Fritz Krusebecker  
McGraw-Hill Publishing Co.  
Liebigstrasse 19  
D-6000 Frankfurt/Main 1  
West Germany  
69 72 01 81

Mrs. Maria Sarmiento  
Pedro Teixeira 8, Off. 320  
Iberia Mart 1  
Madrid 4, Spain  
1 45 52 891

Mr. Andrew Karnig  
Andrew Karnig & Associates  
Finnbodavagen  
S-131 31 Nacka, Sweden  
8-44 0005

Mr. Jean Christian Acis  
McGraw-Hill Publishing Co.  
17 rue Georges Bizet  
F 75116 Paris  
France  
1 720 33 42

Mr. Arthur Scheffer  
McGraw-Hill Publishing Co.  
34 Dover St  
London W1X 3RA  
England 01 493 1451

Mr. Savio Pesavento  
McGraw-Hill Publishing Co.  
Via Flavio Baracchini 1  
20123 Milan, Italy  
011 86 90 656

Seavex Ltd.  
400 Orchard Road, #10-01  
Singapore 0923  
Republic of Singapore  
Tel: 734-9790  
Telex: RS35539 SEAVEX

Seavex Ltd.  
503 Wilson House  
19-27 Wyndham St  
Central, Hong Kong  
Tel: 5-260149  
Telex: 60904 SEVEX HX

Hiro Morita  
McGraw-Hill Publishing Co.  
Overseas Corp  
Room 1528  
Kasumigaseki Bldg  
3-2-5 Kasumigaseki,  
Chiyoda-Ku  
Tokyo 100, Japan  
3 581 9811

# R·E·A·D·E·R S·E·R·V·I·C·E

Inquiry No.	Page No.	Inquiry No.	Page No.	Inquiry No.	Page No.	Inquiry No.	Page No.	
69	1ST PLACE SYSTEMS	148	72	COMP COMPNTS UNLTD	386, 387	220	LABORATORY MICROSYS	18
2	2500 AD SOFTWARE	220, 221	73	COMPETITIVE EDGE	360	*	LANGLEYSTCLAIR	147
3	4-5-6 WORLD	466	437	COMPPOWER	481	219	LANIER BUSN.PROD.	398, 399
162	5K COMPUTERS	462	*	COMPUMAIL	458	231	LATTICE INC	198
4	800 SOFTWARE	222	77	COMPUSERVE	215	232	LEADING EDGE PROD.	49
5	A.ST RESEARCH	19	78	COMPUTER AFFAIRS INC.	117	233	LEVEL 5 RESEARCH	299
6	A.ST RESEARCH	19	79	COMPUTER AFFAIRS INC.	470	427	LIFEBOAT ASSOC	419
7	AB COMPUTERS	314	80	COMPUTER CHANNEL	363	428	LIFEBOAT ASSOC	266
8	ABC DATA PRODUCTS	464	*	COMPUTER CHRONICLES	302	235	LINDE TECHNOLOGY INC	26
415	ADPS	86	81	COMPUTER CONNECTION INC.	453	236	LINTEK INC	470
10	ADDMASTER CORP	472	82	COMPUTER DISCOUNT PROD.	455	237	LIONHEART PRESS	416
11	ADV BUSINESS COMP. SYS.	403	*	COMPUTER FRIENDS	190	238	LOCKHEED-GETEX	149
12	ADV COMP PROD	469	83	COMPUTER HUT OF N.E.	130	440	LOGIC PROGRAMMING	371
13	ADV COMPUTER SYSTEMS	376	84	COMPUTER INNOVATIONS	343	441	LOGIC PROGRAMMING	371
14	ADV. DIGITAL CORP	247	85	COMPUTER INNOVATIONS	365	239	LOGICAL DEVICES	218
15	ADV. DIGITAL CORP	247	86	COMPUTER MAIL ORDER	300, 301	240	LOGICAL DEVICES	476
16	ADVANCED LOGIC SYSTEMS	234	87	COMPUTER PARTS MART	470	241	LOMAS DATA PRODUCTS	203
17	AFTEK BUSN MACHINES	35	*	COMPUTER WAREHOUSE	154	242	LYHEN COMP SYS	470
18	ALF PRODUCTS, INC.	320	89	COMPUTERBANC	60	243	LYBEN COMP SYS.	472
19	ALLIED MICRO DEVICES	460	90	COMPUTERLANE UNLTD. INC.	474	244	LYCO COMPUTER	211
20	ALLOY COMPUTER PRODUCTS	344	91	COMPUTERS AND MORE	356	245	MAGNUM PC	290
21	AMARAY CORP	405	92	COMPUTERS WHOLESALE	465	247	MANX SOFTWARE SYS.	53
22	AMBER SYSTEMS	122, 123	93	COMPUTRADE	422	248	MARTIN MARIETTA IIT SFTW.	133
429	AMBER SYSTEMS	329	94	CONROYLAPOINTE	156, 157	249	MARVEL SOFTWARE	433
24	AMERICAN MICROSYSTEMS	466	95	CONROYLAPOINTE	156, 157	250	MARYMAC INDUSTRIES	472
57	AMERICAN RESEARCH CORP.	313	96	CONROYLAPOINTE	156, 157	251	MASTERBYTE COMP OF NY.	476
25	AMPRO COMPUTERS INC.	205	97	CROMEMCO	5	252	MAXELL DATA PRODUCTS	7
26	ANCHOR AUTOMATION	397	98	CUESTA SYSTEMS	358	253	MAYNARD ELECTRONICS	15
27	ANTHRO CORP	369	408	CUSTOM COMP TECH.	153	254	MEGATEL COMPUTER TECH.	86
28	APOLLO MARKETING	452	409	CUSTOM COMP TECH.	449	255	MERRITT COMP PRODUCTS	466
*	APPLE COMPUTER INC.	CII, I	410	CUSTOM COMP TECH.	448	256	MFI ENTERPRISES INC.	150
29	APPLIED SOFTWARE TECH.	242	102	CYMA CORPORATION	331	257	MICRAY ELECTRONICS	174
30	APROPOS TECHNOLOGY	472	103	CYMA CORPORATION	331	433	MICRO AGE COMP STORES	217
31	ARTIFICIAL INT'L RESRCH.GRP.	474	104	DATA BANK	422	258	MICRO DATA BASE SYS	67
32	ARTISOFT	380	105	DATA EXCHANGE	474	259	MICRO DESIGN INT'L	378
33	ARTISOFT	380	107	DATA SPEC	66	260	MICRO MART INC.	62, 63
431	ARTISOFT	84	108	DATA SPEC	66	261	MICRO PRODUCTS INC.	456
432	ARTISOFT	84	109	DATA TRANSLATION INC.	85	262	MICROCOMPUTER ACCESSORIES	295
34	ASHTON-TATE	139	110	DATACOPY CORP	382	263	MICROCOMPUTER ACCESSORIES	295
35	AT&T GENERAL BUSN. SYS.	257	111	DAYNA COMM.	71, 72, 73	264	MICROGRAFX	323
36	AUSTIN SCIENTIFIC	392	112	DECISION RESOURCES	375	*	MICROMINT INC	413
132	AVATEX MODEM	118, 119	113	DECIMATION	470	412	MICROPRO	80, 81
37	AVOCET	173	114	DIGITAL ELECT. SYS	450	265	MICROPROCESSORS UNLTD.	460
38	B&B ELECTRONICS	466	117	DIGITAL PRODUCTS INC.	152	266	MICROSHOP	450
*	B&C MICROSYSTEMS	472	*	DIGITAL RESEARCH COMP.	70	*	MICROSOFT CORP.	20, 21
39	BARR SYSTEMS INC.	64	118	DIRECT-CONNECT DEVICES	462	*	MICROSOFT CORP.	253
40	BAF SYSTEMS	135	*	DISCOUNT COMPUTER CENTERS	291	*	MICROSOFT CORP.	255
41	BAY TECHNICAL ASSOC.	23	119	DISKETTE CONNECTION	424	*	MICROSOFT CORP.	271
42	BEST POWER TECHNOLOGY	361	120	DISKS 'N THINGS	462	*	MICROSOFT CORP.	279
*	BEST WESTERN INT'L.	30	121	DISKS PLUS	468	267	MICROSTUF INC.	236
45	BLACKSHIP COMP SUPPLIES	462	122	DISK WORLD! INC.	475	268	MICROTIME	4
46	BLAISE COMPUTING INC.	394	123	DISK WORLD! INC.	451	269	MICROWAY	276
50	BORLAND INT'L.	28, 29	124	DISPLAY TELECOMMNTNS	486, 487	270	MIDWEST MICRO-PERIPHERALS	34
47	BORLAND INT'L.	41	125	DIVERSIFIED COMPUTER SYS.	460	*	MINORITY HI-TECH INDUSTRIES	254
48	BORLAND INT'L.	43	126	DOKAY COMP PROD INC.	482, 483	272	MOTEL COMPUTERS LTD	320
49	BORLAND INT'L.	45	127	DOW JONES SOFTWARE.	420, 421	273	MTI SYSTEMS CORP.	52
52	BUEHLER SERVICES INC.	470	128	DWIGHT CO. INC.	468	274	MULTITECH SYSTEMS	368
53	BUSINESS TOOLS INC.	308	129	DYNA SYSTEMS	460	276	NANTUCKET	112
*	BYTE BACK ISSUES	439	130	DYNACOMP COMPUTER SYS.	201	277	NANTUCKET	112
*	BYTE PUBL. INC.	415	131	DYSAN CORP	79	278	NAT'L PUBLIC DOMAIN SFTW.	68
*	BYTE SUBSCRIBER SERVICE	172	133	EARTH COMPUTERS	474	279	NATIONAL INSTRUMENTS	50
*	BYTE TIPS	411	134	EASTMAN KODAK CO.	207	74	NCDA	468
1	BYTE TIPS ID CARD	496	436	ECL	481	281	NEC HOME INFORMATION SYS CIII	
54	BYTEK COMP SYS CORP.	424	135	ECOSOFT	18	282	NESTAR SYSTEMS INC	75
*	C WARE DESMET C	256	136	EDUCATIONAL MICROCOMP.	470	283	NEW GENERATION SYS	406
*	C-SYSTEMS	468	137	ELCOMP	481	284	NIGHTOWL SOFTWARE	163
55	C ITOH DIGITAL PRODUCTS	38	138	ELECTRONIC DATA SYS.	219	285	NORTH AMERICAN BUSN.SYS.	410
56	C ITOH DIGITAL PRODUCTS	38	139	ELEK-TEK	364	*	NORTH HILLS CORP.	466
*	CALIF DIGITAL	484, 485	140	ELFXOR INC.	468	*	NORTH HILLS CORP.	468
*	CALIF MICRO COMPUTER	474	*	ELLIS COMPUTING INC.	171	*	NRI SCHOOLS ELECTR. DIV.	417
423	CALIF MICRO HOUSE	280	141	ENCHANTED FOREST	468	286	OBERON INTERNATIONAL	178
58	CANON U.S.A.	283				287	ODESTA PUBLISHING	36, 37
59	CANON U.S.A.	285				288	OLDEN	136
60	CAPITAL EQUIPMENT CORP.	359				289	OPTO-22	352
62	CDR SYSTEMS	460				290	OPTO-22	352
63	CENTROID CORP	464				292	ORION INSTRUMENTS	396
64	CERMETEK MICRO ELECTRONICS	425				420	ORYX SYSTEMS	426, 427
65	CHIPS 'N DIPS	472				421	ORYX SYSTEMS	426, 427
66	CHORUS DATA SYSTEMS	115				422	ORYX SYSTEMS	426, 427
67	CLINICAL MICROSYSTEMS INC.	68				294	PC HORIZONS	476
68	CLOCK COMPUTER CO. LTD.	472				295	PC NETWORK	332, 333
439	COASTLINE COMPUTER	454				296	PACIFIC EXCHANGES	
71	COMP. COMPNTS. UNLTD.	385						466, 468, 474, 476

TO GET FURTHER information on the products advertised in BYTE, either pick up your touch-tone telephone and use TIPS (if you are a subscriber), or fill out the reader service card. Either way full instructions are provided following this reader service index which is provided as an additional service by the publisher, who assumes no liability for errors or omissions. \*Correspond directly with company.





# ONLY PINWRITER DOT MATRIX PRINTERS CAN SAY ALL THIS.

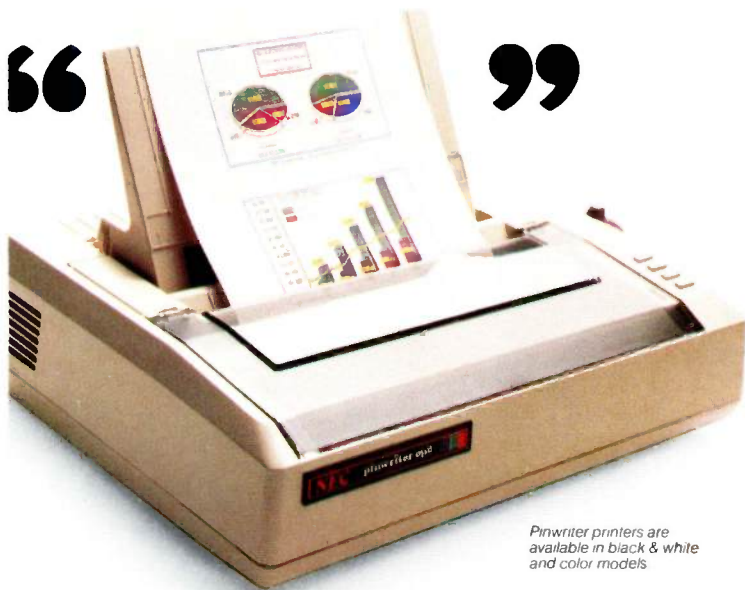

Pinwriter printers are available in black & white and color models

The reason most people buy a dot matrix printer is for versatility.

And that's exactly why you should buy an NEC Pinwriter™ printer.

## Pinwriters are the final word in versatility.

The Pinwriter lets you do more than any other dot matrix printer. Three different speeds cover all your needs—300, 900 or 1800 words per minute.

Pinwriter printers also let you create

unbelievably clear graphics. In black and white. Or in seven crisp colors.

But that's not all. Every Pinwriter gives you a choice of 8 different type styles. Plus, you can choose from a wide range of easy-to-use NEC forms handlers.

With Pinwriter, you can change spacing, type pitch, and speed with one finger

Pinwriter is a trademark of NEC Corp.

And to make things even easier, Pinwriter printers work with the most popular PCs and software packages.

## All the controls at your fingertips.

The Pinwriter is also much easier to use than any other dot matrix printer.

Press a button and you can change typefaces. Or speeds. Even spacing and pitch selection. And that's a refreshing change.

Of course, you can do it through your software, too.

I CAN PRINT PICA HIGH SPEED.  
OR PICA CORRESPONDENCE QUALITY  
OR PICA NEAR LETTER QUALITY  
OR ELITE CORRESPONDENCE QUALITY  
OR ELITE NEAR LETTER QUALITY  
OR PROPORTIONALLY SPACED CORRESPONDENCE  
OR PROPORTIONALLY SPACED NEAR LETTER QUALITY  
OR CONDENSED  
OR ANY PROGRAMMABLE TYPEFACE

The Pinwriter prints in 8 different typefaces at the touch of a button



The quick brown fox  
The quicker brown fox  
The quickest brown fox

Three printing speeds cover all your needs.

See your dealer for a quote.

For all this versatility, you might expect to pay a bundle for a

Pinwriter printer. Not so. Pinwriter prices are also easy to handle.

For more information, call 1-800-343-4418 (in MA call 617-264-8635). And find out why more and more PC owners are saying, "NEC and me."

# NEC AND ME

NEC Information Systems, Inc.

1414 Massachusetts Ave  
Department 1610  
Boxborough, MA 01719

Inquiry 281

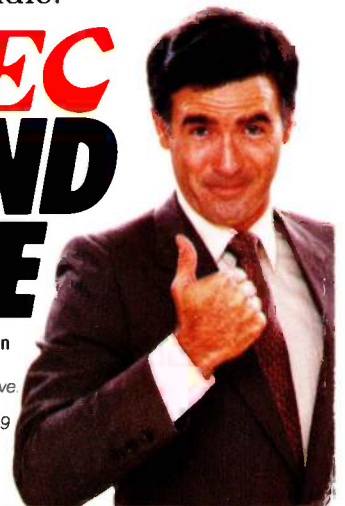



# TANDY... Clearly Superior™

Just look what the experts said  
about the new Tandy 1000.

## On DeskMate™ software:

"It's hard to place a cash value on DeskMate, because it is included in the system price. However, it is fair to say that it takes the place of literally hundreds of dollars of separately purchased software. In fact, we believe that many people will make DeskMate their most-used program."

—Popular Computing

"It is truly integrated and easy to use, and it truly allows you to get your Tandy 1000 up and productive the moment you set it up. It is the crowning achievement of an extremely impressive system."

—Creative Computing

## On value:

"Separately, either the Tandy 1000 or DeskMate would be worthy of serious consideration. Combined, they make a powerful, cost-effective package. Moreover, the Tandy 1000 offers substantial price and feature benefits over its biggest competitors—the IBM PC and PCjr. Clearly, the Tandy 1000 wins this battle in the computer marketing war."

—Popular Computing

## On price:

"... the Tandy 1000's price can't be beat ... businesses with several IBMs already installed can add units for about two-thirds the cost of a PC."

—80 Micro

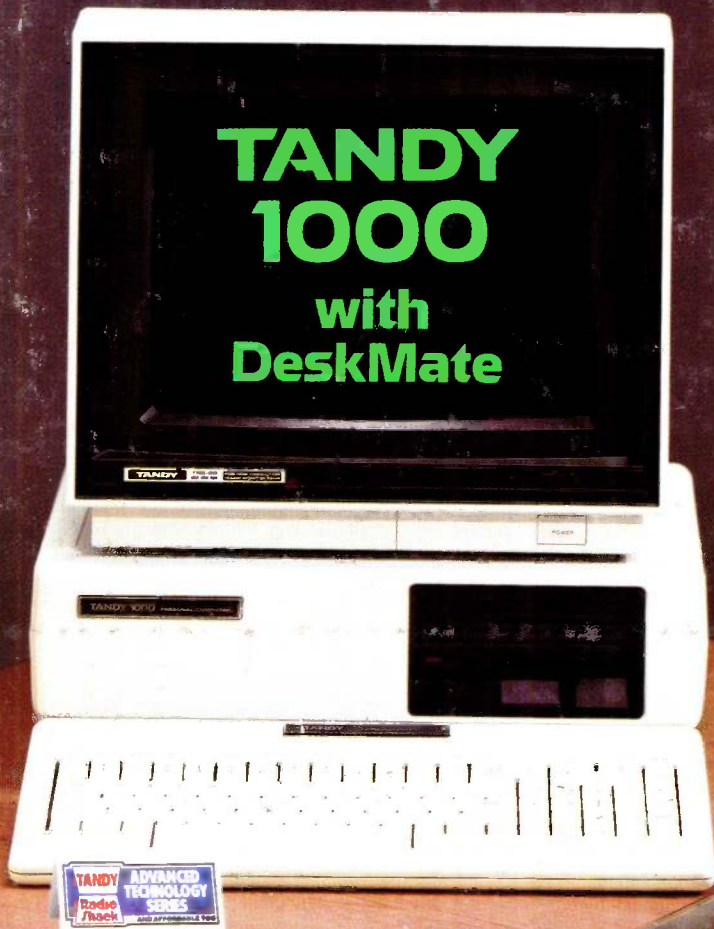

See the Tandy 1000 today.  
It's the best \$2000 computer  
you can buy...for only \$1199\*.

Available at over 1200  
Radio Shack Computer Centers and at  
participating Radio Shack stores and dealers.

**Radio Shack®**  
**COMPUTER CENTERS**

A DIVISION OF TANDY CORPORATION

Inquiry 331