

BYTE

12490



OCTOBER 1983 Vol. 8, No. 10
\$3.50 in USA
\$3.95 in Canada/£2.10 in U.K.
A McGraw-Hill Publication
0360-528Q

the small systems journal

UNIX ON MICROS



THE HP-150 A Touch of Magic

Computer crime
on the increase

NEC's latest
advance



Inside Apple

Vol. 1, No. 3

Apple's new Monitor II. A sight for sore eyes.

If you've been using a TV as a monitor, perhaps you can get a friend to read this for you:

Apple's brand new Monitor II will improve your vision.

It features all the latest ergonomic improvements in monitor technology.

For example:

Studies have shown that the leading cause of eye fatigue for computer users is lack of contrast between the displayed characters and their background.

So we designed the Monitor II around a high contrast green phosphor CRT that provides an extremely dark background. That means you can read text at a lower brightness. And that means you can be more productive — working longer and more comfortably.

Toward that same end, we also gave Monitor II a tilt screen. So you can angle it perfectly for your working position, without scooting your chair around or sitting on phone books.

And we made that screen antireflective to reduce glare from ambient light.

Monitor II also features a high bandwidth video amplifier and a high tolerance linearity circuit. The former keeps characters from smearing

on the screen and eliminates the annoying "ghosts" left by a fast moving cursor. The latter keeps characters crisp, legible and prevents "keystoning" right up to the edges of the display. Both add up to superior display of 80-column text and extremely

accurate graphics.

Designed as the perfect system partner for the Apple IIe Personal Computer, Monitor II requires no monitor stand. It's a perfect fit, aesthetically as well as technically. So it's pleasing to the eye even when it's turned off. See for yourself.

At your local authorized Apple dealer.

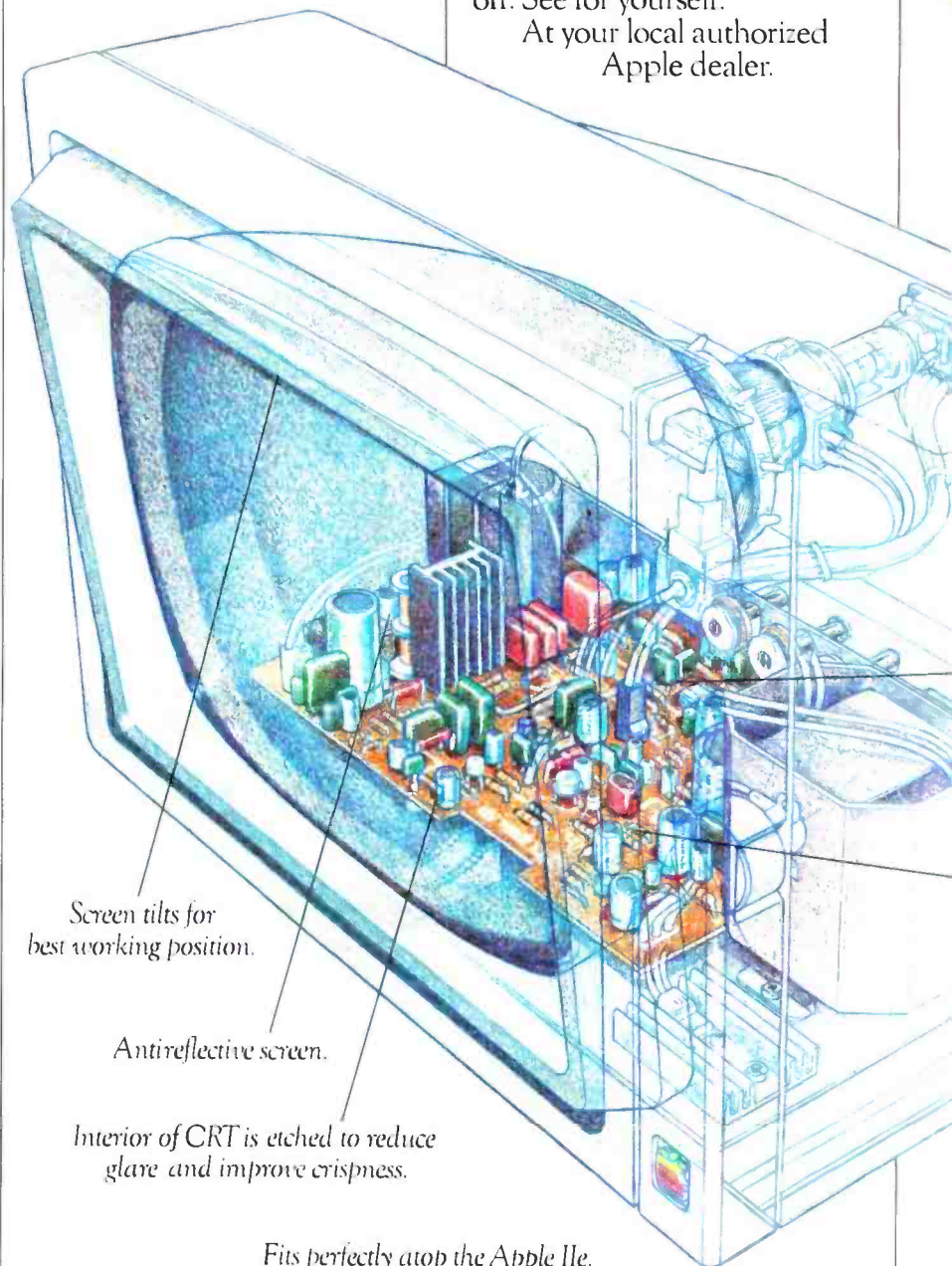

Screen tilts for best working position.

Antireflective screen.

Interior of CRT is etched to reduce glare and improve crispness.

Fits perfectly atop the Apple IIe.

Now Apple plots color.

Since color graphics are becoming ever more important in business, we've been hearing more and more calls for a color plotter as reliable as an Apple.

Here it is:

Apple's new Color Plotter can generate all kinds of presentation graphics, engineering drawings or anything else you have to illustrate in up to eight brilliant colors.

And it can perform its art on any size paper up to 11" x 17". Or, with optional transparency pens, it can draw right on transparent film for overhead projection.

Measuring just 4.8"H x 16"W x 12"D, it's the smallest four-color, wide bed color plotter you can buy — about half the size of conventional flatbed plotters. So it takes up less space on your desk and can easily be

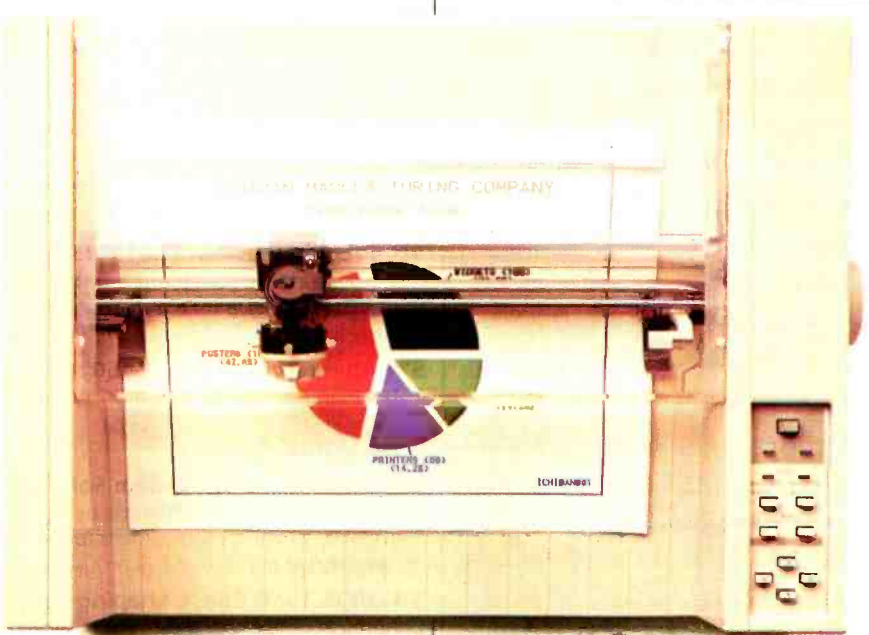

moved to someone else's desk.

There are two color plotter accessory kits to choose from to assure a perfect marriage with your Apple II or IIe, or Apple III.

Each kit comes with eight color pens — red, blue, green, black, burnt orange, gold, violet and brown. Plus a starter package of plotter paper. Plus all the manuals, documentation and cables appropriate to

your particular kind of Apple. So you can get up and coloring right away.

Apple also offers a complete selection of 24 different pen packages — so you can choose whatever colors you need in a variety of widths for a variety of applications and media types.

As you might expect, all of the above is available at many of our authorized Apple dealers.

Carry on with AppleCareSM Carry-In Service.

No matter how long you've owned your Apple system, you can now get a long term service contract at a very reasonable cost.

AppleCare Carry-In Service is a service plan that will cover most Apple-branded components in your system for one full year.

It covers an unlimited number of repairs and is honored by over 1500 authorized Apple dealers nationwide.

Apple-trained technicians assure you of the highest quality service, fast — in most cases less than 24 hours.



AppleCare Carry-In Service is ideal for anyone who needs to know ahead of time the cost of maintenance for their system.

So check out the details — you'll find it's the lowest cost health plan an Apple can have.

High tolerance linearity circuit.

High bandwidth video amplifier.



Page 36



Page 51

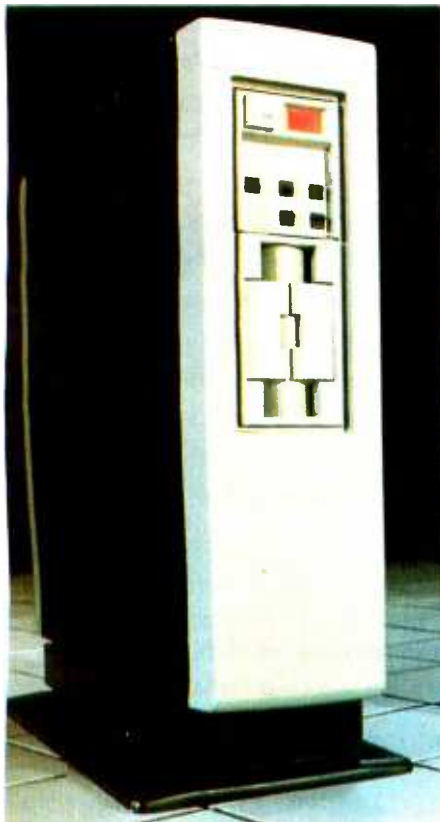

Page 132

Cover Story

36 Product Preview: The HP 150 by Phil Lemmons and Barbara Robertson / "Magic" is the code name for Hewlett-Packard's latest personal computer project—and it fits. In this preview, we take a look at the hardware and software that make the machine so special.

51 An Interview: The HP 150's Design-team Leaders by Phil Lemmons and Barbara Robertson / Jim Sutton and John Lee talk about the development of the HP 150.

Columns

67 Build the Micro D-Cam Solid-State Video Camera, Part 2: Computer Interfaces and Control Software by Steve Ciarcia / In this final article in the series, you'll learn how to attach the camera to the expansion buses of the Apple II Plus and the IBM PC and how the camera is programmed to work.

94 BYTE West Coast: Shaping Consumer Software by Phil Lemmons and Barbara Robertson / In an interview, Trip Hawkins, president of Electronic Arts, discusses the criteria he uses to judge software and explains his view of the programmer as artist.

107 User's Column: New Computers, Boards, Languages, and Other Tidbits by Jerry Pournelle / A medical diagnosis-by-computer program is the star attraction this month.

Themes

130 The Unix Operating System by Bruce Roberts / The multiuser, multitasking operating system developed at Bell Laboratories offers powers and abilities far beyond those of normal microcomputer operating systems. Our theme articles explore the reasons behind Unix's popularity.

132 The Unix Tutorial, Part 3: Unix in the Microcomputer Marketplace by David Fiedler / The final article in this series explains the differences between various Unix versions and between true Unix systems, work-alikes, and look-alikes.

160 Unix and the Standardization of Small Computer Systems by Jean L. Yates / The Unix operating system and the C language will be major factors in the standardization of file handling and compatibility across small systems and mainframes.

170 A Tour Through the Unix File System by James Joyce / A devoted Unix user surveys points of interest in Unix's hierarchy of files.

187 The Unix Shell by Stephen R. Bourne / The author of the standard Unix shell presents the program that interprets users' commands and is a programming language in its own right.

209 Unix as an Application Environment by Mark Krieger and Fred Pack / Unix is the operating system of choice for many programmers because it offers portability, communications capability, a rich set of utilities, and a large body of applications.

219 Usenet: A Bulletin Board for Unix Users by Sandra L. Emerson / A look at a network of more than 500 Unix systems and its various and sundry uses.

241 The Unix Writer's Workbench Software by Lorinda L. Cherry and Nina H. Macdonald / This applications package can improve your writing by analyzing rough drafts and suggesting improvements.

253 Typesetting on the Unix System by Bill Tuthill / With troff, you can typeset manuscripts, tables, and equations with Unix.

266 Moving Unix to New Machines by Michael Tilson / Unix is highly portable, but transporting a large body of software can present problems.

Reviews

280 The NEC Advanced Personal Computer by David B. Suits / The author met the microcomputer of his dreams in the form of high-resolution graphics, color, and 16-bit performance.

BYTE is published monthly by McGraw-Hill, Inc., with offices at 70 Main St., Peterborough NH 03458, phone (603) 924-9281. Office hours: Mon—Thur 8:30 AM — 4:30 PM, Friday 8:30 AM — Noon, Eastern Time. Address subscriptions to BYTE Subscriptions, POB 590, Martinsville, NJ 08836. Address changes of address, USPS Form 3579, and fulfillment questions to BYTE Subscriptions, POB 596, Martinsville, NJ 08836. Second class postage paid at Peterborough, NH 03458 and additional mailing offices. USPS Publication No. 528890 (ISBN 0360-5280). Postage Paid at Winnipeg, Manitoba. Registration number 9321. Subscriptions are \$21 for one year, \$38 for two years, and \$55 for three years in the USA and its possessions. In Canada and Mexico, \$23 for one year, \$42



292 Radio Shack's TRS-80 Model 4 by Rowland Archer Jr. / Offering a host of new features and a new, improved price tag, the Model 4 is proof that large corporations can be responsive to the needs of their customers.

306 The Morrow Micro Decision by Tom Wadlow / A review of the company's first effort at a single-board, stand-alone personal computer.

316 The Microneye by Chris Wieland / Until now, the cost of adding vision to a computer has been out of reach for most users. Now there's the Microneye solid-state camera, which interfaces easily with a variety of popular microcomputers.

324 The M68000 Educational Computer Board by Robert W. Floyd / For \$495, you can get acquainted with a 68000-based single-board computer with 32K bytes of RAM and what the author says may be the best monitor program in RAM ever developed.

341 Fancy Font by Paul E. Hoffman / With this easy-to-use program and an Epson printer, you can design your own type styles.

428 More Unix-style Software Tools for CP/M by Christopher O. Kern / The Microtools package includes the most popular utilities available for the Unix operating system.

Features

350 Photographic Animation of Microcomputer Graphics by Peter Cann / By interfacing a movie camera to a computer, you can achieve the animation quality of commercial movies or television.

366 The Fourth National Computer Graphics Association Conference by Alexander Pournelle / This year's NCGA conference offered improved graphics hardware, but graphics software still leaves a lot to be desired.

384 Echonet, Part 2: The Compiler by C. Bradford Barber / In the conclusion of this series, the author explains how his system produces relocatable code from English-like programs.

398 Computer Crime: A Growing Threat by Collen Gillard and Jim Smith / The machine that provides businesses with a competitive edge is also placing them at the mercy of a new type of lawbreaker—the computer criminal. Fortunately, there are ways to prevent unauthorized computer access.

439 Mainframe Graphics on a Microcomputer by Mahlon Kelly / If you have a smart-terminal program and a microcomputer capable of high-resolution graphics, you can display complex graphics.

447 Talker by Heyward S. Williams / Writing a talking program is simple, says the author, if you can use PRINT and INPUT statements to automatically transfer information to a speech synthesizer.

480 Bitmaps Speed Data-handling Tasks by Eric Sohr / Strings of ones and zeros can make short work of ordered-list comparisons and file searches.

499 Simplified Program Interfacing by Raymond Irvine / A programming technique based on jump and data tables simplifies the interface between two programs when at least one of them has fixed entry points and data addresses.

Nucleus

- | | |
|--|--|
| 4 Editorial: A Challenge to Education | 570 Books Received |
| 7 MICROBYTES | 574 Event Queue |
| 12 Letters | 586 What's New? |
| 540 User to User | 669 Unclassified |
| 548 Ask BYTE | 669 BYTE's Ongoing Monitor Box and BOMB Results |
| 556 Software Received | 672 Reader's Service |
| 566 Clubs and Newsletters | |

Cover photograph by Arbogast Photography

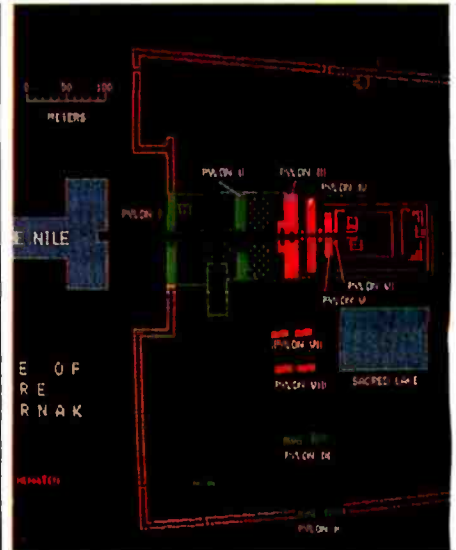

Page 280

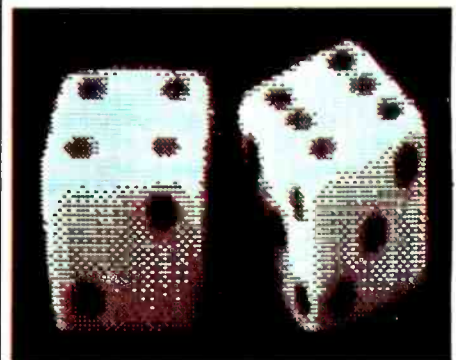

Page 67



Page 350

for two years, \$61 for three years, \$53 for one year air delivery to Europe, 17,100 yen for one year surface delivery to Japan, \$37 surface delivery elsewhere. Air delivery to selected areas at additional rates upon request. Single copy price is \$3.50 in the USA and its possessions, \$3.95 in Canada and Mexico, \$4.50 in Europe, and \$5.00 elsewhere. Foreign subscriptions and sales should be remitted in United States funds drawn on a US bank. Printed in the United States of America.

Subscription questions or problems should be addressed to:
 BYTE Subscriber Service, POB 328, Hancock, NH 03449



Editor In Chief: Lawrence J. Curran

Managing Editor: Pamela A. Clark

Senior Technical Editors: Gregg Williams, Richard Malloy

Technical Editors: Richard S. Shuford, Curtis P. Feigel, Arthur A. Little, Stanley Wszola, Bruce Roberts, Gene Smarte; Anthony J. Lockwood, New Products Editor; Steve Ciarcia, Consulting Editor; Mark Welch, Staff Writer; Alan Easton, Drafting Editor.

West Coast Editors: Philip Lemmons, Bureau Chief; Barbara Robertson, Technical Editor; Donna Osgood, Assistant Editor. McGraw-Hill, 425 Battery Street, 4th Floor, San Francisco, CA 94111 (415) 398-7990

Copy Editors: Nancy Hayes, Chief; Warren Williamson, Elizabeth Kepner, Joan V. Roy, Dennis E. Barker, Anne L. Fischer; Margaret Cook, Junior Copy Editor

Assistants: Faith Kluntz, Beverly Jackson, Lisa Jo Steiner, Jeanann Waters

Production: David R. Anderson, Assoc. Director; Jan Muller, Virginia Reardon, Michael J. Lonsky; Sherry McCarthy, Chief Typographer; Debi Fredericks, Donna Sweeney, Valerie Horn

Advertising: Deborah Porter, Supervisor; Marion Carlson, Rob Hannings, Cathy A. R. Drew, Lisa Wozmak, Jeanne Cilley, Jeanna Reenstierna; Patricia Akerley, Reader Service Coordinator; Wai Chiu Li, Quality Control Manager; Linda J. Sweeney, Advertising/Production Coordinator

Advertising Sales: J. Peter Huestis, Sales Manager; Sandra Foster, Administrative Assistant
Circulation: Gregory Spitzfaden, Director; Andrew Jackson, Subscriptions Manager; Barbara Varnum, Asst. Manager; Agnes E. Perry, Louise Menegus, Jennifer Price, Mary Emerson; James Bingham, Single-Copy Sales Manager; Deborah J. Cadwell, Asst. Manager; Carol Aho, Linda Turner

Marketing Communications: Horace T. Howland, Director; Vicki Reynolds, Coordinator; Timothy W. Taussig, Graphics Arts Manager; Michele P. Verville, Research Manager

Business Manager: Daniel Rodrigues

Controller's Office: Kenneth A. King, Asst. Controller, Mary E. Fluhr, Acct. & DIP Mgr.; Karen Burgess, Linda Fluhr, Vicki Bennett, Vern Rockwell, Lyda Clark, Janet Pritchard, JoAnn Walter, Julie Ferry

Traffic: N. Scott Gagnon, Manager; Brian Higgins, Cynthia Damato

Receptionist: Linda Ryan

Personnel/Office Manager: Cheryl A. Hurd

Publisher: Gene W. Simpson; John E. Hayes, Associate Publisher/Production Director; Doris R. Gamble, Publisher's Assistant

Editorial and Business Office: 70 Main Street, Peterborough, New Hampshire 03458 (603) 924-9281

Officers of McGraw-Hill Publications Company:
President: John G. Wrede; Executive Vice Presidents: Paul F. McPherson, Operations; Walter D. Serwatka, Finance & Services. Senior Vice President-Editorial: Ralph R. Schulz. Senior Vice President Publishers: Harry L. Brown, David J. McGrath, James R. Pierce, Gene W. Simpson, John E. Slater. Vice President Publishers: Charlton H. Calhoun III, Richard H. Larsen, John W. Patten. Vice Presidents: Kemp Anderson, Business Systems Development; Shel F. Asen, Manufacturing; Michael K. Hehir, Controller; Eric B. Herr, Planning and Development; H. John Sweger, Jr., Marketing.

A Challenge to Education

Lawrence J. Curran, Editor in Chief

Two months ago, I editorialized about Project Athena, an effort at the Massachusetts Institute of Technology to explore how advanced computers and computer graphics can change the ways in which university students learn (August, page 4). Both Digital Equipment Corporation and IBM Corporation are contributing valuable equipment and services to the project, which is named after the Greek goddess of wisdom. I applauded those companies, along with Apple Computer Inc., for their contributions to education. Apple has donated several million dollars worth of personal computers to more than 9000 public and private schools in California.

Now it's time to applaud Radio Shack for undertaking "America's Educational Challenge," a program intended to introduce computer literacy in the earliest grades possible. The program will help elementary and secondary school teachers to teach students about computers by assisting teachers to become computer literate themselves. Three years ago—even before it formalized this program—Radio Shack took steps to acquaint educators with computers by allowing them free use of equipment in Radio Shack training centers.

In announcing the details of America's Educational Challenge earlier this year, John V. Roach, president and chief executive officer of Tandy Corp., explained why training facilities, located at more than 400 Radio Shack Computer Centers, had been opened to educators. He said educators had repeatedly indicated that they couldn't effectively communicate with students about computers until they themselves became computer literate.

Roach also commented that Radio Shack's efforts grew out of the company's conviction that most Americans under the age of 40 will have to become computer literate in the next decade. We agree, and we commend Tandy/Radio Shack for undertaking America's Educational Challenge. The program enables teachers to take three courses that provide 24 hours of computer training, including an introduction to BASIC, BASIC programming, and a workshop intended to give professional educators an overview of microcomputer applications in the classroom.

In addition to a certificate authorizing free teacher training, Radio Shack has sent the following to more than 103,000 U.S. schools: an educator's handbook describing how microcomputers are used in schools, a basic computer-literacy package designed to teach elementary computer concepts with duplication masters, a secondary-level textbook that illustrates programming concepts, examples of what other school districts are doing with computers, and an order form that enables teachers to sign up for additional computer training.

Radio Shack deserves recognition for sponsoring the program. Of course, it can't help but stimulate sales of Radio Shack computers and software when teachers who have been trained on the equipment decide to purchase their own computers or have an opportunity to influence a school's purchase. But the cost to Radio Shack for only the teacher-training portion of the program could top \$10 million if only 2 percent of those being offered the classes took them. That's a substantial investment that carries no clear guarantee that only Radio Shack will benefit from the influence of AEC-trained teachers. ■

CHAMELEON BY SEEQUA... TWICE THE COMPUTER FOR \$1995 (Introductory Offer).

BOTH WORLDS OF PROCESSING

16 bit 8086 IBM compatible software runs under MS-DOS and industry standard 8 bit Z80A software runs under CP/M.

TWICE THE MEMORY

128K bytes RAM are standard, internally expandable to 256K. And dual IBM PC compatible 5 1/4" disks with 160K formatted each are included.

The following are registered trademarks:
CP/M-80 — Digital Research Inc.
MS-DOS — Microsoft
PC-DOS — IBM
Perfect Writer — Perfect Software
Perfect Calc — Perfect Software
MBasic — Microsoft

SOFTWARE INCLUDED

Your computer is delivered with SEEQUA's MS-DOS, compatible with the IBM standard 16 bit PC-DOS operating system. It includes Perfect Writer for word processing and Perfect Calc for financial analysis. And it has MBasic to let you write your own routines. Chameleon comes standard with 640 x 200 resolution black and white graphics and 320 x 200 resolution color graphics.

EXPANDABLE

Chameleon has both serial and parallel ports standard. You can add an additional serial port or the IEEE-488 port. You can even use IBM PC compatible add-on boards in our optional expansion interface package.

FITS IN YOUR ENVIRONMENT

Chameleon is at home in your office. But its compact packaging makes it easy to carry elsewhere.

To learn more about Chameleon's power, call us at 800-638-6066. We'll put you in touch with our closest dealer.

CHAMELEON

by



**SEEQUA
COMPUTER
CORPORATION**

209 West Street
Annapolis, MD 21401
(301) 268-6650
(800) 638-6066



How to buy a computer by the numbers.

Introducing the Cromemco C-10 Personal Computer. Only \$1785, including software, and you get more professional features and performance for the price than with any other personal computer on the market. We've got the numbers to prove it.

The C-10 starts with a high-resolution 12" CRT that displays 25 lines with a full 80 characters on each line. Inside is a high-speed Z-80A microprocessor and 64K bytes of on-board memory. Then there's a detached, easy-to-use keyboard and a 5 1/4" disk drive with an exceptionally large 390K capacity. That's the C-10, and you won't find another ready-to-use personal computer that offers you more.

But hardware can't work alone. That's why every C-10 includes software — word processing, financial spread sheet, investment planning and BASIC. Hard-working, CP/M[®]-based software that meets your everyday needs. Software that could cost over \$1000 some-

where else. FREE with the C-10. There's really nothing else to buy.

But the C-10's numbers tell only part of the story. What they don't say is that Cromemco is already known for some of the most reliable business and scientific computers in the industry. And now for the first time, this technology is available in a personal computer.

One last number. Call **800 538-8157 x929**

for the name of your nearest Cromemco dealer, or to request literature. In California call 800 672-3470 x929. Or write Cromemco, Inc., 280 Bernardo Avenue, P.O. Box 7400, Mountain View, CA 94039. In Europe, write Cromemco A/S, Vesterbrogade 1C, 1620 Copenhagen, Denmark.

CP/M[®] is a registered trademark of Digital Research, Inc. All Cromemco products are serviced by TRW.

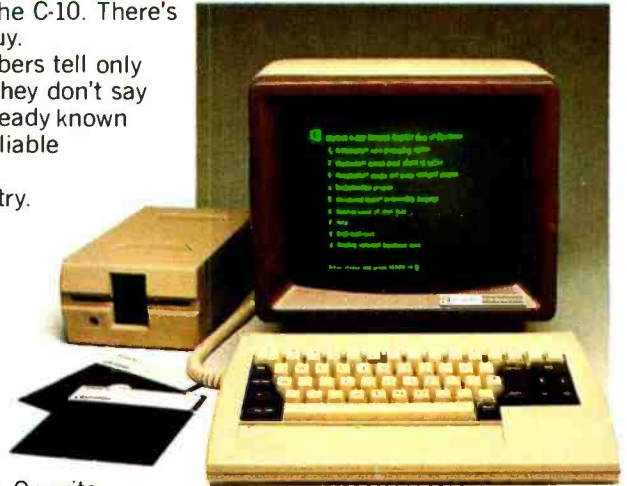

Cromemco
Tomorrow's computers today

Circle 127 on inquiry card.

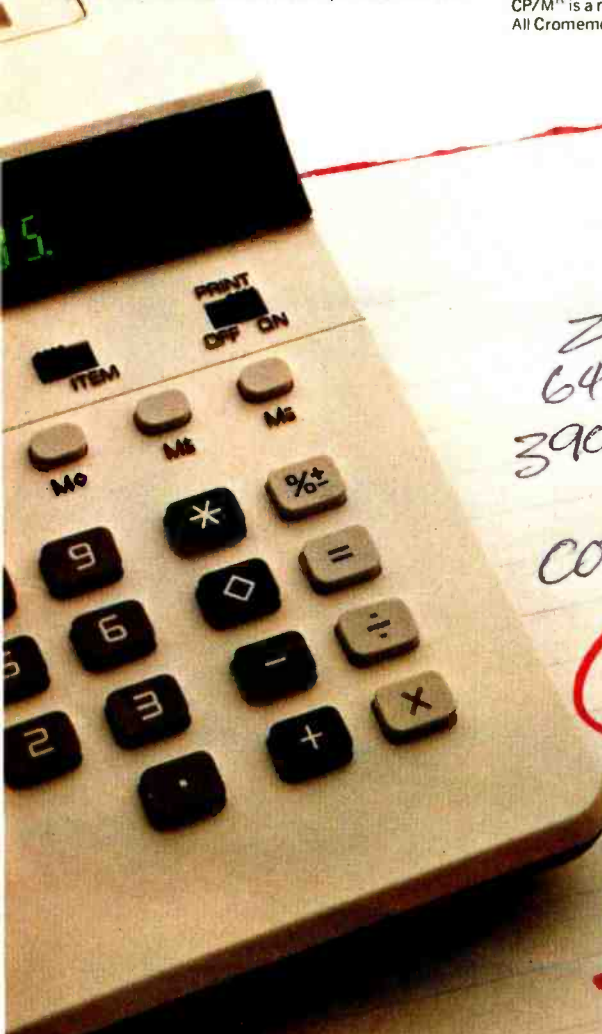

Z-80A
64K RAM
390K DISK DRIVE
12" CRT
COMPLETE SOFTWARE

\$1785

CROMEMCO

MICROBYTES

Staff-written highlights of late developments in the microcomputer industry.

WESTERN ELECTRIC IS FIRST IN U.S. 256K DRAM MARKET

Western Electric, New York, NY, is now selling its 256K-bit dynamic random-access memory (DRAM) chip, which is currently being shipped. Previously, Western Electric had made components only for its own products.

Several other U.S. firms are developing 256K DRAMs for shipment in 1984. Motorola plans to ship samples to companies in the fourth quarter of 1983 and offer production quantities in early 1984, while Intel, Micron Technologies, Texas Instruments, INMOS, and National Semiconductor are expected to begin shipping sample 256K chips during the first half of 1984. While other firms prepare 256K- by 1-bit DRAMs, Mostek, Carrollton, TX, has announced that it will begin shipping samples of a 32K- by 8-bit DRAM this month. Mostek expects that architecture will result in less expensive, less complicated designs but is also working on a 256K- by 1-bit DRAM.

Despite Western Electric's experience in the design of semiconductor products, the other entrants into the 256K DRAM market don't consider it any different from other competitors. One firm projects the sales of 256K DRAMs at several billion units per year by 1988 and is uncertain that any one company can dominate that large a market. Just as significant in the industry are the six Japanese companies reported to be designing or shipping samples of 256K DRAMs: NEC, Oki, Fujitsu, Hitachi, Mitsubishi, and Toshiba. The Japanese have already achieved a dominant market position in 64K DRAMs. In addition, Siemens Corp. is reported to be developing a 256K DRAM in Europe.

Oki Semiconductor says it will ship 10,000 units per month in the U.S. starting this month. Oki expects to ship about 20 percent of all 256K DRAMs worldwide in 1984, or about 600,000 of 3 million units it predicts will be sold.

SHORTAGES AND DELAYS OF COMPONENTS AND MEMORY PLAGUE MICROCOMPUTER COMPANIES

A rapid increase in orders for microcomputer components and memory has led to shortages and delays for some products. The earliest pinch was in 64K-byte RAM chips, but high demand for other components has also led to production delays as suppliers receive unanticipated orders and must either delay shipment or ship partial orders. National Semiconductor, which abandoned its 64K DRAM chip in early 1983 because of production problems, planned to manufacture the Oki Electric 64K DRAM starting in September and hopes to have its own version in production by mid-1984.

Low-power CMOS components, logic circuit chips, and even the popular Z80 microprocessor are becoming hard to get. In late summer, lead times for many versions of these products were 14 to 16 weeks, as compared to less than two weeks in February. New orders for one National Semiconductor logic circuit won't be shipped for at least 30 weeks.

Of several computer manufacturers contacted, most say they haven't been hurt by the pinch, though many agree a problem exists and that it could get worse. Most said they have long-term contracts with suppliers for their needs and speculated that new companies might have more problems.

TELELEARNING CREATES AN ELECTRONIC UNIVERSITY

Telelearning, San Francisco, CA, has announced an Electronic University through its networking system. The company will sell a software and modem package that enables owners of the IBM PC, Apple II, or Commodore 64 with at least one disk drive to access Telelearning's network system. The package will cost from \$119 to \$200, depending on the computer. Users can then select courses for \$50 to \$200 each, access course materials, and ask questions of the instructor through the network. Access is through Tymenet, Telenet, and Uninet at no additional charge.

TEXAS INSTRUMENTS AND TIMEX TRY TO BOOST SALES OF LOW-COST COMPUTERS

Texas Instruments, Lubbock, TX, has extended the \$50 rebate on its 99/4A computer until January 31, 1984, and extended its warranty to one year. TI will also provide 99/4A buyers with a free five-hour course or a free "Teach Yourself BASIC" cassette. In addition, TI has cut the price of a disk-drive/memory system: the expansion unit, a 32K-byte RAM cartridge, and a disk drive and controller will be combined for a retail price of \$550, down from \$1200.

In another effort to boost sales, Timex Computer Corp., Waterbury, CT, is giving away a Timex watch to buyers of a Timex/Sinclair TS1000 and a RAM pack. Timex will also offer two free software packages for every two purchased.

WANG ANNOUNCES A HIGH-DENSITY MEMORY MODULE

Wang Laboratories Inc., Lowell, MA, has announced the single in-line memory module (SIMM), a high-density memory package that fits nine 64K-bit RAM chips into a ¾- by 3-inch space on a printed circuit board. Wang hopes to use 256K chips in the SIMM in the future and predicts that the SIMM could fit 1 megabyte of memory in a 3- by 4-inch area using industry-standard mounting practices.

INTERLAN ANNOUNCES A \$400-PER-DEVICE ETHERNET LINK

Interlan Inc., Westford, MA, has announced a terminal server to link personal computers and peripherals to Ethernet for as little as \$400 per device. Any computer, printer, modem, or other device with an RS-232C (serial) interface can be attached to the NTS-10 terminal server, which links to Ethernet. An eight-port NTS-10 costs \$3200, while a four-port version is \$2500.

MYSTERY FIRM SIGNS LARGE CONTRACTS WITH IMI, TANDON

Tandon Corp., Chatsworth, CA, has announced a \$310 million contract with an unnamed buyer for floppy-disk drives. International Memories Inc. (IMI), Cupertino, CA, also announced a contract with an unnamed firm for more than \$100 million worth of 5¼-inch Winchester hard-disk drives. The contracts will probably account for half of each company's business through 1984.

ONYX, SCHUCHARDT, AND MICRORIM UNVEIL INTEGRATED SOFTWARE FOR UNIX, IBM

Onyx Systems, San Jose, CA, has announced what it says is the first integrated software package for the Unix operating system. The Onyx Office includes a user interface "shell" that links word-processing, spreadsheet, database-management, and calendar features. Written in C, the package will be available in mid-October.

Schuchardt Software Systems, San Rafael, CA, has unveiled Intesoft, an integrated software package for the IBM Personal Computer. Based on Intebase, a \$495 database-management system, the Intesoft series also includes a \$295 spreadsheet, a \$149 time planner, a \$195 critical-path package, and a \$195 interactive application generator for creating other software. Five additional packages, including a word processor, should be available later this year.

Microrim, Bellevue, WA, has unveiled a new database-management package with "gateways" to other popular programs. R:Base can use files generated by Visicorp's Visicalc, Lotus's 1-2-3, Micropro's Wordstar, Microsoft's Multiplan, and Ashton-Tate's dBase II as well as Microrim's own database files. The package is available for the IBM PC for \$495 and will soon be available for Unix.

NANOBYTES

Vault Corp., Westlake Village, CA, has introduced a new software-protection system, the Prolok disk. At the time of manufacture, the disk is physically modified with a unique "fingerprint." Programs can be backed up to another disk but won't run without the fingerprint, which can't be copied or erased. . . . **Radio Shack**, Fort Worth, TX, has introduced a 64K version of its TRS-80 Color Computer. The revised system features a typewriter-quality keyboard, a white case, and Extended BASIC for \$399.95. Radio Shack is also offering a single-button mechanical mouse for the Color Computer for \$49.95. . . . **Sorcim Corp.**, San Jose, CA, has added graphics capabilities to its Supercalc spreadsheet program. Supercalc 3, on one single-sided disk for a 64K IBM PC or Compaq, will cost \$395. Sorcim is working on a CP/M version. . . . **Direct Inc.**, Santa Clara, CA, is introducing a \$3995 16-bit computer with full mainframe terminal capabilities. The 8088-based 1600 Series includes MS-DOS, a Z80 processor for CP/M-80 applications, and either an HP 2620-compatible or a DEC VT-131-compatible terminal. . . . **CBS Inc.** and **Tandy Corp.** have agreed to grant each other software conversion rights. . . . **Apple Computer**, Cupertino, CA, has introduced a four-pen color plotter for \$995. . . . **The Micropro User's Group (MUG)**, Larkspur, CA, has been established for users of Micropro International Corp. software, including Wordstar, Calcstar, and Infostar. . . . **Micropro** is now selling Wordstar for Concurrent CP/M-86. . . . **Visicorp**, San Jose, CA, has introduced Visicalc IV, combining Visicalc with Multisoft Corp.'s \$99 Stretchcalc. Adding graphics and sorting features, Visicalc IV for the IBM PC costs \$295. . . . **Western Digital Corp.**, Irvine, CA, reports that its Ada compiler for its \$20,000 Series 1600 microcomputer has been approved by the U.S. Department of Defense. . . . **North Star Computers**, San Leandro, CA, is offering a "flexible" bundle of software with its Advantage and Horizon computers. Users can choose from among 26 programs—\$1100 to \$2000 worth of software—offered by North Star. . . . **Morrow Designs**, San Leandro, CA, has introduced the Micro Decision MD-11, a \$2745 hard-disk version of its Z80-based MD-1.

ATARI COMPUTER OWNERS:

Pick the positively perfect, practical, **printer-port** peripheral package, from **PERCOM DATA!**

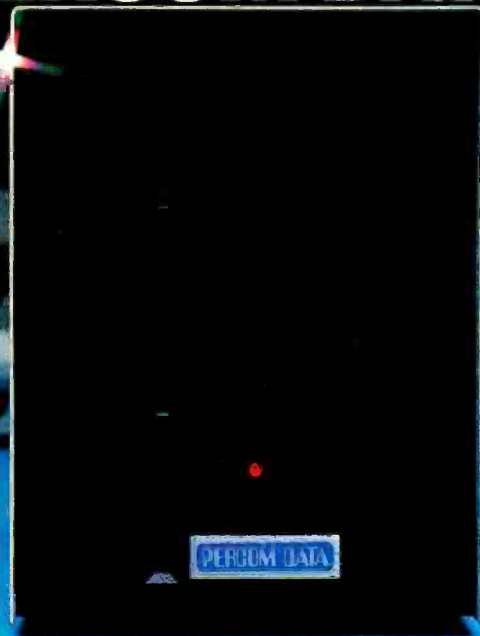

That's right... the positively perfect PERCOM DATA 5¼", floppy disk drive with a BUILT-IN PRINTER-PORT, for your Atari® 400/800 is now available!

Until now, Atari computer owners who wanted to hook a printer to their computer had only one choice... spend about \$220 for an interface device. THOSE DAYS ARE OVER, PERCOM DATA has built a parallel printer-port right into its new AT88 PD model. Now you can add a quality disk drive system AND have a place to plug in a printer... WITHOUT BUYING an interface.

The AT88 S1 PD™ disk drive operates in both single density (88K bytes formatted) and double density (176K bytes formatted).

What more could you want? NO INTERFACE... a high quality PERCOM DATA disk drive... AND a built-in PRINTER-PORT... all with a price of \$599.

Pick up a positively perfect PERCOM DATA disk drive, with printer-port... pronto!

For the name of an authorized PERCOM DATA Dealer near you, call our **TOLL-FREE HOTLINE 1-800-527-1222 NOW**, or write for more information.

Perfectly Priced

\$599.

PERCOM DATA
CORPORATION

Expanding Your Peripheral Vision

DRIVES • NETWORKS • SOFTWARE

11220 Pagemill Road, Dallas, Texas 75243 (214) 340-5800
1-800-527-1222

Atari is a registered trademark of Atari, Inc. • AT88 S1 PD is a trademark of Percom Data Corporation. • COPYRIGHT PERCOM DATA CORPORATION 1983.
Prices subject to change without notice.

Circle 357 on Inquiry card

www.americanradiohistory.com

Intertec Offers The Warranty Your First Computer Should've Offered.

One-Year Factory Warranty.



The rationale behind the conventional 90-day warranty is that anything likely to go wrong will go wrong in the first 3 months.

But it can take 3 months just to get comfortable with a new system. That's the honeymoon-period, when you treat your equipment with the delicacy of a safecracker.

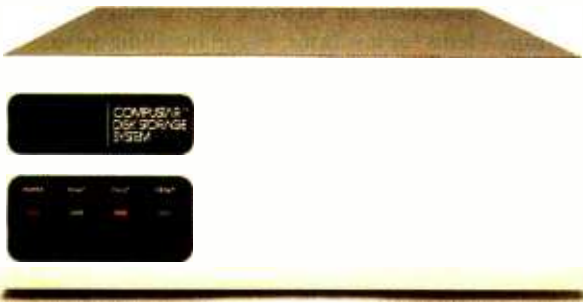

CompuStar can network up to 255 intelligent terminals and give each of them access to common or restricted databases.

Ah, but now it's 5 months down the road, the honeymoon is over, your equipment has finally begun to justify its cost, and that's the afternoon your processor's fan succumbs to fatigue.

Or maybe the malfunction is more gradual, like a disk-head drifting increasingly out of alignment.

Or more elusive, like an intermittent failure due to borderline components.

When You Build Them Stronger, You Can Back Them Longer.

And that's why all Intertec terminals, computer networks and disk storage systems come with a full year of coverage. Not because you'll need it, but to assure you that you won't.

*CP/M is a registered trademark of Digital Research.

*Microsoft Basic is a registered trademark of Microsoft Corporation.

See—unlike other makers, we know what we're standing behind.

We don't slap Intertec nameplates on other people's parts. We build virtually all our equipment ourselves.

And we assemble it ourselves.

And we test and re-test it ourselves.

More Bytes For Your Buck.

That's also why we can offer you flatly superior dollar-values.

In single-user desk tops, for example, our SuperBrain offers twin Z80s, standard;

64 kbytes of dynamic ram, standard; up to 1.5 mbytes of disk storage, standard; CP/M 2.2* and MBasic[†] standard.

And compared to conventional multi-user systems, our CompuStar systems can give you many more hours of productive labor every day—because, instead of depending on a central processor for data manipulation, each workstation in a CompuStar network has its own processor and its own 64 kbytes of ram.

As a result, you can have anywhere from 2 to 255 workstations working simultaneously without suffering noticeable declines in execution-time.

Why Just Expand When You Can Up-Grade?

In fact, if you assess your expansion alternatives in terms of relative payback potential,

you're very likely to find that up-grading with Intertec equipment from scratch would be more cost-effective than burdening your existing installation with add-on's.

Dollar for dollar, the Intertec system is apt to be not only faster, more powerful and more versatile, but more *reliable* and better supported.

Service On Site? Within 4 Hours?

In addition to our one-year warranty, and the carry-in service provided by authorized Intertec dealers, we also have 600 factory-trained technicians to provide service on-site in 120 U.S. cities, often within 4 hours.

To arrange for that service

Since we build our equipment from scratch, we can afford to do it right and still hold down our prices.

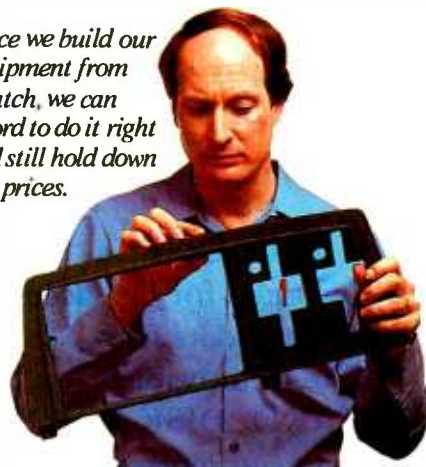

just call our Customer Services Department at 803/798-9100. At the same time we'll be happy to give you the name of your nearest Intertec dealer.

Or write on your letterhead to Intertec Data Systems Corporation, 2300 Broad River Road, Columbia, SC 29210.

intertec



Apple® II, IIe
5 megabyte
Removable
HARD_DISK™
\$1,295

HARD_DISK is designed for fast access to large data files. The Removable **HARD_DISK PAC™** can even replace floppy diskettes as a very reliable backup media and eliminate the need to add floppy disk drives.

One Year Warranty

205-871-0987

Digital Electronics Systems

107 Euclid Avenue
Mountain Brook, AL 35213

HARD_DISK, PAC are trademarks of Digital Electronic Systems, Inc.
Apple II, IIe is a trademark of Apple Computer, Inc.

Letters

Feedback on IBM PC Word Tools

"Word Tools for the IBM Personal Computer" by Richard S. Shuford (May, page 176) has done more to educate me on the subject than any other source I have been able to locate. I just had to write and let you know how much I enjoyed it, even though I am not an IBM PC owner.

In particular, I found his comparison table valuable, and I appreciate the perspective imparted by comparison of the programs (Volkwriter, Easywriter II, Wordstar, and The Final Word) on the basis of what they do (and don't do) well. I'm sitting at the edge of my keyboard waiting to learn the name of the mysterious fifth program, which he used to edit the article.

I noticed a string of features and commands in his comments on The Final Word that appear to be nearly identical to those in Perfect Writer. As examples, the embedded style commands in photo 12 on page 210 appear identical to those in Perfect Writer, and the features described in column 2 of the text on that page also bear striking resemblances. Is there a common origin for these characteristics?

Loren Marshall
1705 Bartlett Dr.
Anchorage, AK 99507

The "mysterious" fifth program was Sorcim Corporation's Superwriter, which I used to write about two-thirds of the text in the review (the other third of the text was written using The Final Word, and I banged out most of the large table on my electric typewriter). We plan to review Superwriter and several other new word-processing programs in future issues.

Both Mark of the Unicorn's The Final Word and Perfect Software's Perfect Writer owe their inspiration to the EMACS text-editing system developed by Dr. Richard Stallman at the Massachusetts Institute of Technology. Perfect Writer and Mark of the Unicorn's MINCE mimic EMACS more closely than does The Final Word. . . . R.S.S.

I was very pleased to read the section on "preliminary cautions" in "Word Tools for the IBM Personal Computer" and then choose word-processing software based on those needs. I think reviewers often

miss the crucial point that the user's own needs should be analyzed first. I have a few observations from my own experiences with a variety of word-processing programs that some readers may find interesting. (I have never used an IBM PC, but my experiences with CP/M-80 word processors certainly have the same implications for PC owners.)

About a year ago, our company, which specializes in software and turnkey systems for law firms, began installing an extensive multiprocessor CP/M-compatible system in our pilot-site law firm. Word processing is the cornerstone of law-office automation, so we were eager to identify the best possible software for the firm. We looked at Benchmark, Select, and some others but finally found two derivatives of EMACS: Perfect Writer and The Final Word. Perfect Writer, after evaluation, seemed a better choice than The Final Word. One reason was that we didn't like the forward/reverse orientation of The Final Word and preferred Perfect Writer's separate commands for backward and forward operations. In addition, I use Perfect Writer to compose my PL/I source code and find it excellent for this purpose. However, our attempt at implementing it for the law firm was an utter disaster.

A question that word-processing users should ask themselves is: "Am I primarily a text creator/manipulator, or am I a text printer?" I would say that programmers, lawyers, and other professionals are largely text manipulators in that they either do not have a need for perfectly formatted print or they have support staff do their printing for them. Secretaries and other clerical workers are certainly interested in text-creation features, but to them the bottom line is getting that letter, brief, or report to their bosses or in the mail in the proper format at the proper time.

After a few months of using Perfect Writer, this distinction became obvious to us. The embedded formatting-commands approach of Perfect Writer was impossible for a busy law firm in which countless printed documents are produced each day. We found that just one simple formatting-command mistake would ruin the format of an entire document, and even a simple two-page letter required enough of these embedded commands to make at least one mistake likely. It frequently required seven or eight attempts before a document printed correctly. Although we clung to Perfect Writer for a long time, we

With all the clamor about personal computers, a fundamental fact is often overlooked: some simply *work* better than others.

Consider the COMPAQ Portable.

A computer will make you more productive. A computer will make you more efficient. You hear it everywhere. But you don't hear much about which computer actually works best.

The COMPAQ Portable fits under a standard airline seat for business trips.

Works in more places

With the COMPAQ™ Portable, you can be as productive in your hotel room or your lake house as in your own office. It's a reliable companion on a business trip. It's a powerful sales aid in your customer's office.

You can move it from office to office to share its resources. You can move it into the conference room to answer questions.

What's more productive than a computer? A computer that works for you in more places.

Works with the greatest number of programs

The most important consideration when choosing a computer is "what programs will it run?"

The COMPAQ Portable runs more programs than any other portable. In fact, it runs more than most non-portables because it runs all the popular programs written for the IBM® Personal Computer without any modification. There are hundreds of them. They are available at computer stores all over the country.

Imagine the power of a portable word processor. There are dozens of word processing programs available for the COMPAQ Portable.

Planning, problem-solving, and "what-ifs" are a cinch with a variety of popular electronic spreadsheet programs. The COMPAQ Portable

runs them all.

There are accounting programs for anything from computerizing your family budget to full-scale professional management of payables, receivables, inventory, and payroll.

There are programs for making charts and programs for communicating with other computers.

So you get portability and you don't give up problem-solving power.

The combination adds up to the most useful personal computer on the market today.

Add-on options make it work the way you work

Inside the COMPAQ Portable are three open slots. Most portables don't have any. Electronic devices called expansion boards fit those slots and give the COMPAQ Portable new powers. As with programs, expansion boards designed for the IBM will work. With them, you can make your personal computer more personal.

Want to check a stock price? One expansion board enables the COMPAQ Portable to handle those communications over ordinary phone lines.

Want to use your company's central computer files while you're on a trip? There are boards that allow the COMPAQ Portable to communicate with a variety of large computers.

Other boards let you hook up controllers for computer games, increase memory capacity, or connect several personal computers in a network.

The added usefulness is free

The COMPAQ Portable doesn't cost any more than an ordinary desktop computer. In fact, it costs hundreds less than a comparably equipped IBM or Apple® III. The COMPAQ Portable comes standard with one disk drive and 128K bytes of memory, both of which are usually extra-cost options.

The bottom line is this—you just can't

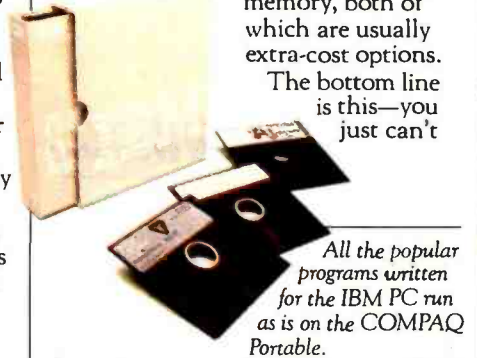

buy a more practical, useful, productive computer. Compare the COMPAQ Portable.

For the location of the Authorized Dealer nearest you, call 1-800-231-9966.

©1983 COMPAQ Computer Corporation
COMPAQ™ is a trademark of COMPAQ Computer Corporation.
IBM® is a registered trademark of International Business Machines Corporation.
Apple® is a registered trademark of Apple Computer Corporation.



COMPAQ™

The most computer you can carry

eventually relented and installed Wordstar. "What you see is what you get" has proven to be the answer.

I strongly believe that the most important factor in choosing word-processing software is deciding whether text creation or text printing is most important. If the user is a text printer, then by all means go with an "on-screen-formatting" type system and avoid the "embedded-commands" systems like The Final Word and Perfect Writer. Once you have made this distinction, then you can leisurely compare sophisticated features among "on-screen" systems.

Paul W. Stackhouse
Robert Glass & Company
 1 Liberty Sq.
 Boston, MA 02109

Double-Spacing with Wordstar

I learned a great deal from Richard S. Shuford's lengthy review of word-processing programs for the IBM Personal Computer. As an admirer and a heavy user of Wordstar, I am often amused when I observe that some of the important special features of the program are unknown even by the experts. I learn something new about the program almost every month.

This is a prelude to pointing out an error in your article. You complained that to print out single- and double-spaced versions of the same manuscript you have to reformat all the paragraphs before the second printing. Not true. The dot command controls line spacing. If it is the last dot command used at the beginning of the manuscript, it will not only print any desired line height (in $n/48$ ths of an inch), but it will also display page breaks on the screen where they will occur during printing. So you can choose any line height you want, edit on the screen single-spaced, and see the page breaks where they will occur when the manuscript is typed to your specifications. If you want to print two copies of the manuscript with different line spacings, you need only change the single dot command at the beginning of the text and resave. The program will take care of all the rest.

David Gutman
 5448 East View Park
 Chicago, IL 60615

The method of reformatting for line spacing (for double- or single-spaced text)

by the Control-Q, Control-Q, Control-B sequence is not completely satisfactory because extra Return characters must be inserted or removed between the paragraphs for consistent spacing. Reformatting the line spacing by the .LH dot command works if you have one of the daisy-wheel printers supported by Micropro, but Wordstar does not seem to support the feature for some less-common daisy-wheel units and most dot-matrix printers. . . . R.S.S.

I enjoyed the review of four word-processing programs. There is a way, however, to change the line spacing in Wordstar other than reformatting each paragraph, which I found out by writing to Micropro International. I received this answer: at the beginning of the document, insert these two dot commands that will be interpreted by the Mailmerge routine:

.PF ON
 .LS 1 (or 2)

The first line turns on print-time formatting; the second line sets the single- or double-spacing.

Bruce J. McLaren
 203 Briarwood Dr.
 Terre Haute, IN 47803

Acquiring Mailmerge does indeed give you more formatting capability, but the scope of the review was limited to only the four basic software products. In addition to Micropro's Mailmerge and Spellstar, many software products from outside vendors are on the market to add capability to Wordstar. . . . R.S.S.

I may be able to help Mr. Shuford with one of his Wordstar difficulties: single-spacing drafts and double-spacing submissions.

Instead of running Wordstar on an IBM PC with an IBM or Epson printer, I'm using a new Morrow Micro Decision with a Star Micronics Gemini-10 printer and running the 8-bit CP/M Wordstar. I understand, however, that the Gemini-10 uses the same control codes and has essentially the same capabilities as the IBM or Epson (except for the Gemini-10's proportional font), so this might work.

When I'm using normal type (10 characters per inch, 65 characters to a line), I always insert

.bp on
 .po 0

at the beginning of the text (and see the question mark come up on the first line). Then, before printing, I run a simple Microsoft BASIC program that contains a printer menu. For this form, it effectively does

"LPRINT CHR\$(27); "M"; CHR\$(10); CHR\$(27); "Q"; CHR\$(75);"

—telling the printer that the left margin is 10 and the right limit is 75. That way, the printer runs full speed and does the work. (It makes a big difference in throughput: I'm getting better than 50 cps (characters per second) start-to-finish speed on articles using Wordstar, including waits, formfeeds, and all.)

For the double-spaced submission, you add "CHR\$(27); "A"; CHR\$(24)" to your LPRINT, and you add these lines at the beginning of your Wordstar document:

.pl 33
 .mt 1
 .hm 1
 .fm 1
 .mb 4

These define a shorter Wordstar page with narrower margins, modified slightly to deal with the linefeed you get compliments of the LPRINT statement. That is five lines of typing (of course, you can have it as a text file on the Wordstar disk and copy it in to the document), but it's better than reformatting. I'm inclined to make a single inspection pass through the document before printing to check page breaks. Note that one other thing had to be done, because the original-version Gemini buffer is either loading or printing, never both: change the transmission speed to 9600 bits per second. I've got the serial board—necessary for the Morrow—and it works like a champ at 9600 bps.

Walt Crawford
 The Research Libraries Group
 Stanford, CA 94305

I don't have a Star Micronics Gemini-10 printer handy, so I tried this with my Epson MX-80 with Graftrax-Plus. Aside from the Epson's lack of a printer command to set the left margin, the double-spacing worked, and the method does print somewhat faster than Wordstar unaided. (Incidentally, the later "X" ver-

NOW AVAILABLE
Only \$275.00 Suggested Retail



QUADCOLOR™ BY QUADRAM™

The first and only color graphics adapter board your IBM PC or XT will ever need.

- Most advanced color graphics board you can buy.
- 136 different colors, and expandable memory.
- No additional board or modification needed to run existing software—completely PC-compatible.
- Serves your graphics needs today... ready to meet your expanded needs tomorrow.

Start with Quadcolor I

Quadcolor I adapts to any color monitor and starts you off with 32K of memory. That means that in text mode you get 16 active video pages with a 40 column format or 8 pages with 80 column. Twice as many as IBM's Color Graphics Adapter offers.

When you switch to the graphics mode, Quadcolor I's 32K memory lets you create two complete pages. You can even modify one page while the other is being displayed, for special effects like animation.

Choose 2 true colors for high-resolution displays on RGB monitors. With Quadcolor, there's no reason to limit yourself to black-and-white.

Display shown on screen produced with Quadcolor II.
IBM is a registered trademark of International Business Machines Corporation.

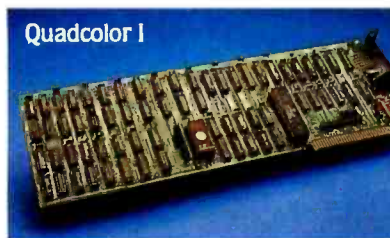

Quadcolor I also offers support for a light pen and an RF modulator connector for use with a home television set.

Grow with Quadcolor II

As your needs change, plug Quadcolor II into Quadcolor I and get a total of 96K of memory combined with higher resolution bit-mapped graphics. Quadcolor II also includes BASICQ, a software package that

enhances the IBM's own BASIC capabilities.

Display graphics like a bar chart, and text like graph labels, together on the same screen. Now that's Quadcolor teamwork.

When you're in the mood for fun and games, Quadcolor II has a game port available for your use.

The choice is clear

Quadcolor is the only graphics board that can offer you all these features and the solid tradition of Quadram Quality. Nobody even comes close. So be sure you choose tomorrow's color graphics board today—Quadcolor by Quadram.

With Quadcolor, looking good never looked so good.



4355 International Blvd./Norcross, Ga. 30093
(404) 923-6666/TWX 810-766-4915 (QUADRAM NCRS)

Circle 384 on inquiry card.

© Copyright 1983 Quadram Corporation
All rights reserved

MOOR



MORROW

There's a certain kind of person who buys a Morrow business computer.

The kind of person who doesn't follow the crowd. In business. Or away from it. You've succeeded by making your own decisions.

And when it comes to a decision on computers, you know that you don't have to pay a lot of money to get a lot of computer. Morrow knows that too.

That's why we make a complete line of systems, including software, from \$1599 to \$2745. Plus letter-quality printers starting at \$595. All, with performance so reliable you'll probably never need the nationwide service we offer from Xerox.

But maybe you don't know this: We've just introduced a hard-disk system with more performance at a lower price than anything else on the market. Anything.

The new MD11 includes an 11MB hard disk; 400K of floppy memory; 128K RAM; 8K ROM; 2 serial, 1 parallel and a main frame communications port. Add the legendary speed of the Morrow controller, a complete package of software, plus a full-size terminal, and you may not be ready for the price: \$2745, complete.

Morrow has never built computers to please everybody. We build them for people who demand value.

It's simple. Those who know buy Morrow.

The computer for independent people.

Morrow, 600 McCormick Street, San Leandro, CA 95477
For the Morrow dealer nearest you, call: (800) 521-3493
(415) 430-1970 In California

New 11MB MD11 for \$2745

Circle 316 on inquiry card.



Letters

sions of the Gemini printers are supposed to have remedied the bottleneck of the single-minded character buffer.) . . . R.S.S.

Searching for the Unsearchable

There was one error in Mr. Shuford's comments that might be significant to people deciding whether to buy Wordstar. He says it "is not possible to use the search functions to locate embedded print-attribute characters. If you want to change all of your underlined text to bold-face, you have to search for it the hard way—by eye."

This is true for only three of Wordstar's approximately 20 print-attribute commands: the ones for alternate character width, nonbreak space characters, and underlining. (Their codes, Control-A, -O, and -S, are used in the search functions as wildcard codes to allow searching for ambiguous characters.) Even so, there are ways around this problem.

People using Wordstar with a modern dot-matrix printer will not often have a problem with Control-S because they'd

probably rather use an italic font instead of underlining. I have set up Control-R and Control-Q to turn italics on and off.

By the way, it is possible to enter Control-A, -O, and -S in a *replace* string, so a second way to handle the problem is to write the document with another character string substituting for the unsearchable one until the time comes to print, then replace it. This is especially appropriate when printing a draft on a dot-matrix printer and the final copy on a daisy-wheel unit.

A third approach is to surround the unsearchable characters with searchable characters that do nothing. I use Control-D, Control-X, and Control-Y in this way:

IDISID
IXIOIX
IYIAY

These guardian characters are ordinarily used as toggles and cancel out after two occurrences. In the search string, I enter:

IDISID
IXISIX
IYISYIY

(Here, Control-S has its special wildcard meaning: search for a nonalphabetic or nonnumeric character.) If you've used a double-strike, strikeout, or ribbon-color-change as the printing-attribute character, you'll find it, too. (This should not cause trouble unless you are replacing globally.)

Admittedly, these added key codes are tedious unless you set up a keyboard macroinstruction using a program like Smartkey (from ICI Computers, POB 255, Aurora, CO 97002) under CP/M-80 or Prokey (from Rosesoft, POB 5850, Seattle, WA 98105) under PC-DOS.

The remainder of the 20-odd printing codes can be searched for in the usual manner, but enter them into the search string *as they appear on the screen*, not as you would while typing them into the document. Some control codes are used for cursor movement in the search functions; Control-P must be entered before them—this somewhat obscure requirement is a frequent source of confusion.

One important reason to search for the Control-A and Control-S codes is to make sure that their attributes are eventually turned off, so your printout doesn't go on with page after page of underlining or

JUST SAY THE PASSWORD™ TO GET 1200 BAUD, PROGRAMMABLE AUTO DIAL, FOR \$449*

- 300/1200 Baud
- Auto Dial, Telpac™ software available
- Full or Half Duplex
- Audio Phone Line Monitor
- Two-Year Limited Warranty

Password™ is the new USR™ friendly modem, designed for use with any small computer on the market today. We have compressed into its miniature (shown actual size) case every operating feature for unattended high speed telecomputing. With auto dial/answer and auto mode/speed select there is little to do but turn it on. So compact it mounts on the computer with Velcro®; when you carry your computer you can pocket your Password. So brilliantly conceived it achieves all this with just 12 tiny integrated circuits (a presage of long trouble-free service). If your dealer doesn't know the Password yet, write or call for complete specifications.

*Suggested list for Password complete with power, phone, RS232 interface cables. Telpac™ software optional extra, \$79.

Password, Telpac, USR logo and the U.S. Robotics corporate name are all trademarks of U.S. Robotics Inc.



U.S. ROBOTICS INC.™

1123 WEST WASHINGTON
CHICAGO, ILLINOIS 60607
(312) 733-0497

Circle 485 on inquiry card.



OPEN YOUR APPLE TO A WORLD OF COMMUNICATION

Videx' new PSIO Dual Function Interface Card gives you a whole new world of communication... with a whole new ease of operation.

The PSIO allows you to use a printer (parallel output) and a modem (serial I/O port) simultaneously, through use of just one card! But best of all, the PSIO makes communicating through either method worlds easier than it's ever been before.

The PSIO lets you choose from among an unmatched range of software-selectable options, including variable baud rate selection, form width, form length, auto linefeed, linefeed mask, Xon/Xoff protocol, lowercase masking, shift wire mod support, duplex mode, parity, data format, video echo mode and a slot echo mode.

PSIO can also open up new worlds for graphics, since it can reproduce your picture on any graphics printer. Rotate your picture, enlarge it, change it as you wish.

Once you've chosen your options, the PSIO's highly sophisticated NOVRAM (non-volatile RAM) will remember and permanently save them. That means you won't have to give the same configurations over and over again... your PSIO will do it for you. And if you want to *change* those configurations, you can do it through software instead of through the confusing array of switches that other cards use.

The PSIO will work with any printer/modem you now happen to own... and it will work with any printer/modem you happen to purchase in the future. Adaptable? Definitely!

The PSIO is completely compatible with BASIC, Pascal and CP/M® systems.

The PSIO from Videx... how in the world can you do without it?!

Circle 497 on inquiry card.



Letters

character spacing. It's a good idea to do this with all print functions that modify more than a single character.

John S. Allen
40 Rugg Rd.
Allston, MA 02134

Mr. Allen has rightly pointed out that most of the attribute characters can be searched; I'm sorry that I did not exhaustively test for searching all the printing-attribute characters. (A minor quibble: in addition to Control-S, -O, and

A, Control-N cannot be used in a search string.) However, it seems desirable to have program features work identically for all possible cases. When a feature works in one case and not another, the user will probably be confused and will certainly be burdened with keeping track of what works and what doesn't. He or she will probably disregard the feature. Likewise, for most users, if a feature is poorly documented it might as well not exist.

Several other readers who wrote to inform me about how Wordstar works on

8-bit CP/M-80 systems were not aware of the differences in support and documentation in the 16-bit IBM PC version. Until the recent release of PC-DOS Wordstar version 3.3, many customization features enjoyed by 8-bit users were simply not available to IBM PC users. But aside from slightly better installation options and faster writing of screen displays, version 3.3 is not very different from the Wordstar I tested. . . . R.S.S.

TRS-80 Model 16 Problems

We recently purchased a Radio Shack Model 16 microcomputer and upgraded a Model II to a 16. We were faced with the prospect of no software for the Model 16 for over six months. The software promised by Radio Shack has finally arrived and is a version of Xenix. A Microsoft BASIC (TRS-Xenix BASIC) interpreter is also available.

We were especially interested in obtaining what we expected would be a superior performing BASIC interpreter. The 68000 processor would appear to offer a significant performance advantage over the Z80. We have run some simple benchmarks (benchmarks No. 1 and No. 2) to test the speed of the new 68000-based interpreter. Frankly, we're shocked!

Enclosed is a copy of the two benchmarks and timed results for various computers. Because of the poor performance of the TRS-Xenix system, we were concerned about the effective clock speed of the 68000 in the Model 16. We ran another benchmark and found the clock speed of the 68000 to be about 6 MHz, as advertised by Radio Shack. Clearly something is seriously wrong with the TRS-Xenix BASIC and perhaps even with Xenix as it is implemented on the Model 16. We need a faster BASIC interpreter and are hoping some software supplier will help us recover the investment we have made in Radio Shack equipment.

We are not confident, though, that the Model 16 can be improved significantly. We have run two benchmarks on the Model 16, one using TRSDOS-16 with an assembly-language program, and Microsoft BASIC in the Z80 mode. The benchmark echoes the character "1" to the screen 10,000 times. The assembly-language version uses TRSDOS-16 system calls. Shockingly, the BASIC version runs twice as fast. In our opinion, the speed of the Model 16 is totally unacceptable. We

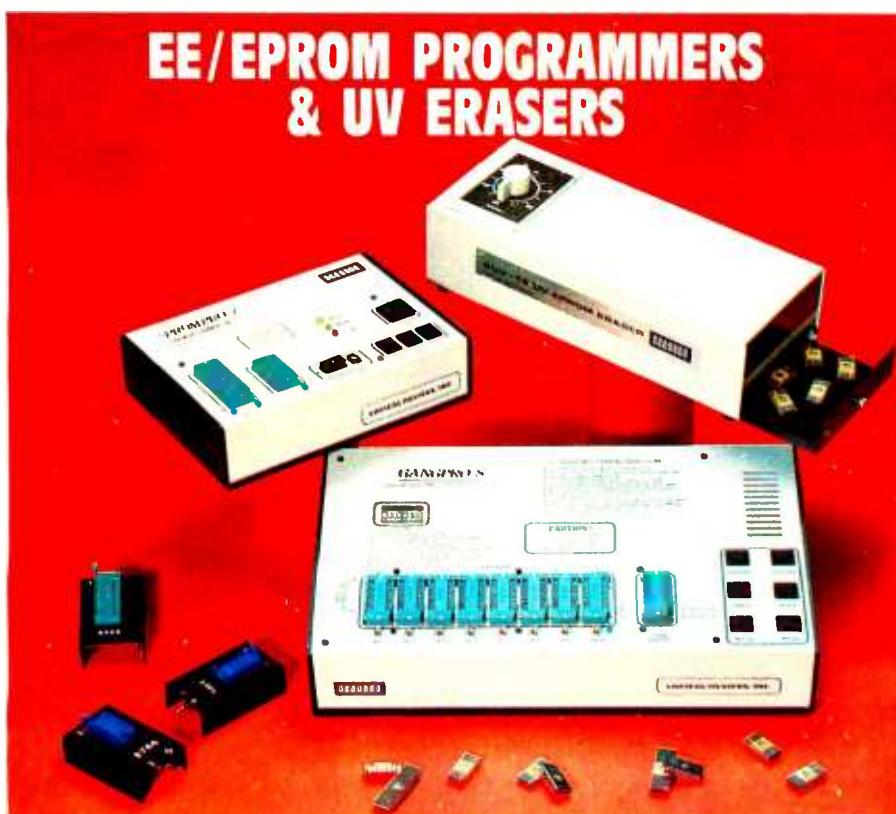

GANGPRO-8™ MULTIPROGRAMMER\$1295.00

GANGPRO-8™ allows user to program up to 8 EE/EPROMS simultaneously using the latest state of the art programming algorithms. It can test and duplicate a wide variety of devices from 16K to 256K. There are no personality modules to buy. 8 digit alphanumeric display prompts user with messages. This unit is extremely easy to operate and is ideally suited for a production environment.

QUV-T8™ series UV EPROM ERASERS

QUV-T8/2T (\$97.50) is an industrial quality eraser, designed in a steel enclosure with a 5" wide tray UV indicator lens, antistatic pad, 60 minute rugged timer and safety interlock switch are standard. Capacity is 24 EPROMS, 15-20 minutes erase time for 15 EPROMS.

QUV-T8 / Z (\$124.95) Similar to QUV-T8/2T (with 40% faster Erase Time)

QUV-T8 / 2N (\$68.95) Same as the QUV-T8/2T version without the timer and safety interlock switch.

QUV-T8 / 1 (\$49.95) Economy model in a molded two part plastic case. Erases 15 EPROMS in 15 minutes

*MCS-48 is a registered trademark of Intel Co

PROMPRO-7™ SERIAL RS-232 STAND-ALONE\$489.00

MCS-48™ FAMILY PROGRAMMING WITH PROMPRO-7™ PROMPRO-7™ is an intelligent self-contained unit, ideally suited for engineering development, or for field service & production. It can program and verify a wide variety of 8K to 128K EPROMS. This unit has a 32K (4K BYTES) internal RAM Buffer that could be accessed by the user through a computer or terminal. This unit can also program the micro chips such as the 8478, 8749, 8751, 874L, 8742, 8755. The price includes all modules up to 32K EPROMS & The 8748 & 8749H Micros Upload/download is done by either Motorola or Intel Hex format.

PROMPRO-8™ SERIAL RS-232 STAND-ALONE\$689.00

This extremely versatile programmer has as much as 128K (16Kx8) of internal RAM dedicated to the EE/EPROMS. This RAM buffer can be accessed either through a computer terminal, or by user target system (EPROM emulation). PROMPRO-8 8 digit alphanumeric display prompts user with the system messages. A keypad option is available for standalone editing. An impressive range of devices are programmed (as standard feature).

The Right Equipment for Your Eeproms at the Right Price!



AVAILABLE SOFTWARE DRIVERS
1. IBM PC 2. APPLE II 3. MDS-ISIS 4. CPM
5. TEKTRONICS 8002 6. ATARI 7. TRS-80 COLOR 8. FLEX

LOGICAL DEVICES, INC.
1321-E N.W. 65th PLACE, FORT LAUDERDALE, FLORIDA 33309
TEL. (305) 974-0967 - TWX. 510-955-9596
DISTRIBUTORS WELCOME FOR QUALIFICATIONS

Circle 272 on inquiry card.

double sided.
double density.

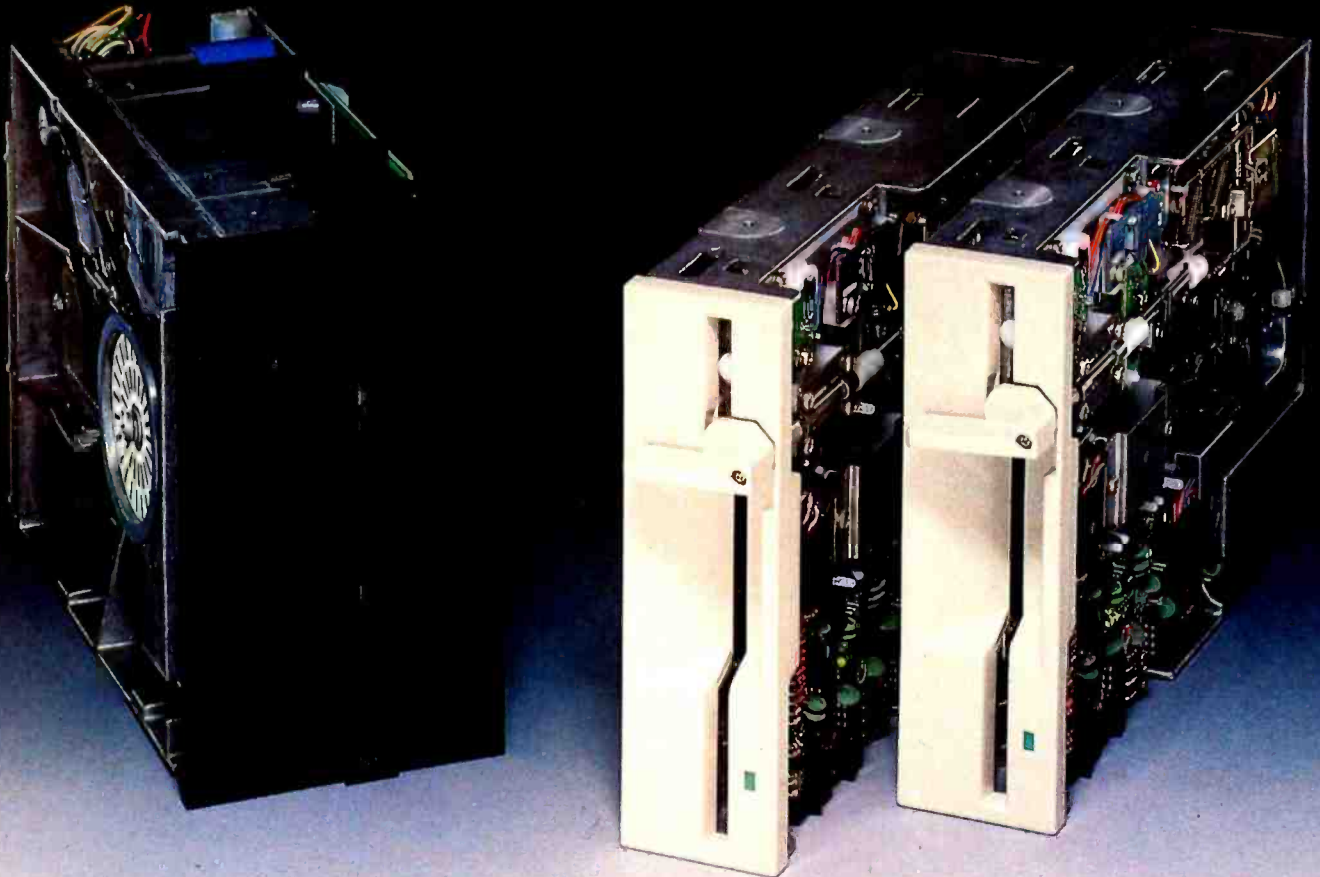

Plug compatible with standard 5 $\frac{1}{4}$ " drives, but occupying just one-half the space, these Amdisk-V minifloppy disk drives are engineered for solid performance and reliability . . . and they're available now!

Drives are available with black faceplate.

Just circle the reader service number for complete specifications and quantity pricing.

2201 Lively Blvd. • Elk Grove Village, IL 60007
(312) 364-1180 TLX: 25-4786

REGIONAL OFFICES: Calif. (714) 662-3949 • Texas (817) 498-2334

AMDEK

Amdetek . . . your guide to innovative computing!

Circle 32 on inquiry card.

**Rana's disk drive was
twice as good as Apple's
with one head.**

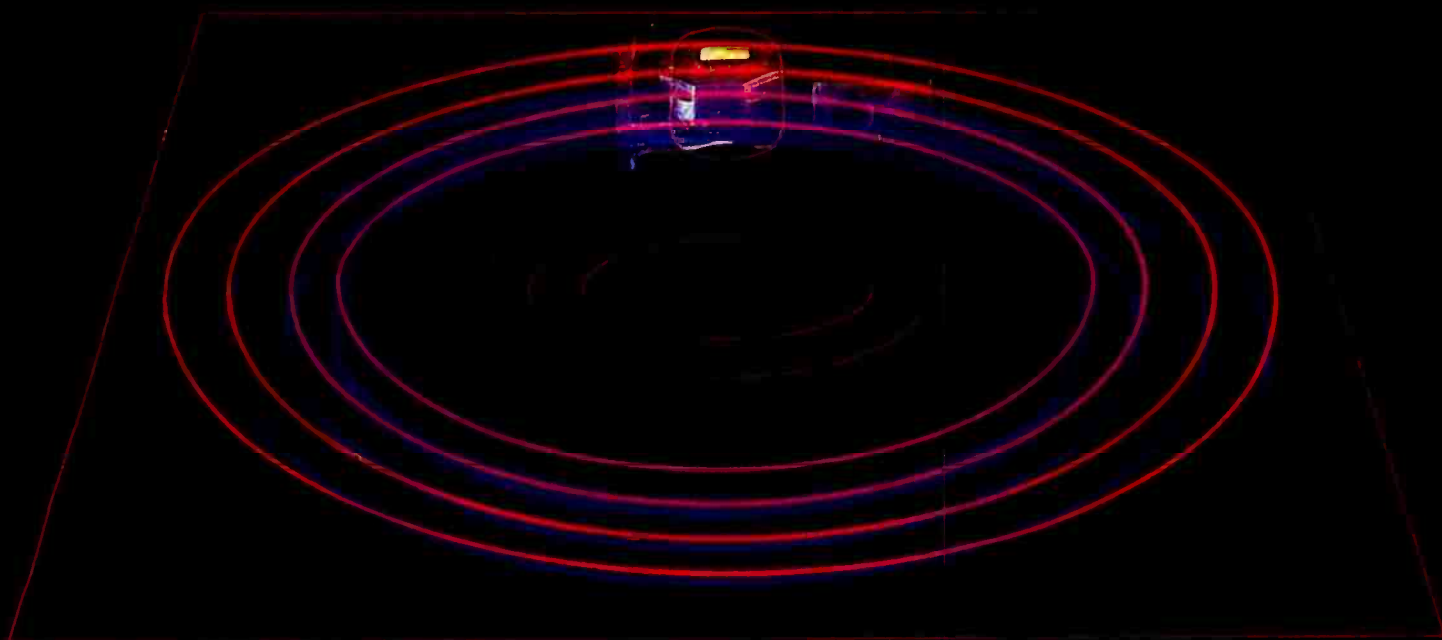

Now we have two.

We added another head so you won't have to buy another disk.

That's the beauty of a double sided head. A floppy disk which allows you to read and write on both sides. For more storage, for more information,

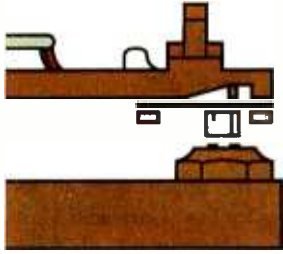

Rana's double sided heads give Apple II superior disk performance power than second generation personal computers such as IBM's.

for keeping larger records, and for improved performance of your system. That's what our new Elite Two and Elite Three offers. It's the first double headed Apple® compatible disk drive in the industry. And of course, the technology is from Rana. We're the company who gave you 163K bytes of storage with our Elite One, a 14% increase over Apple's. And now with our high tech double sided heads, our Elite Two and Three offers you two to four times more storage than Apple's. That's really taking a byte out of the competition.

We put our heads together to give you a superior disk drive.

We designed the Elite Three to give you near hard disk capacity, with all the advantages of a minifloppy system. The double sided head operates on 80 tracks per side, giving you a capacity of 652K bytes. It would take 4½ Apples to give you that. And cost you three times our Elite Three's reasonable \$849 pricetag.

It takes 4½ Apples to equal the capacity of our superior Elite Three.

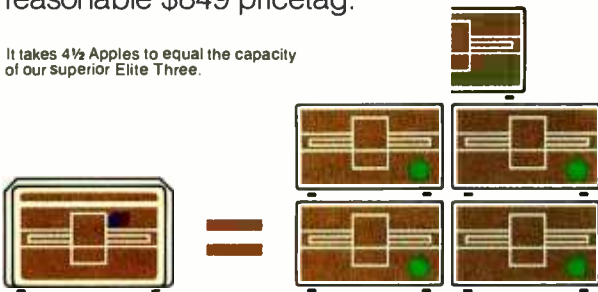

The Elite Two offers an impressive 326K bytes and 40 tracks on each side. This drive is making a real hit with users who need extra storage, but don't require top-of-the-line capacity. Costwise, it takes 2½ Apple drives to equal the performance of our Elite Two. And twice as many diskettes. Leave it to Rana to produce the most cost efficient disk drive in the world.

We've always had the guts to be a leader.

Our double sided head may be an industry first for Apple computers, but nobody was surprised.

© Apple is a registered trademark of Apple Computer, Inc.

Circle 395 on inquiry card.



They've come to expect it from us. Because Rana has always been a leader. We were the first with a write protect feature, increased capacity,

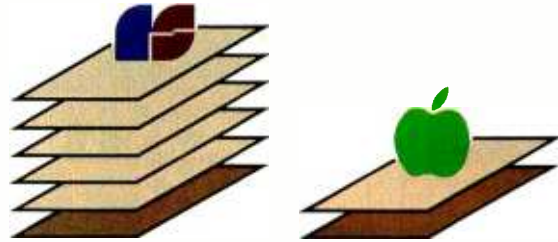

Your word processor stores 5 times as many pages of text on an Elite Three diskette as the cost ineffective Apple.

and accurate head positioning. A first with attractive styling, faster access time, and the convenience of storing a lot more pages on far fewer diskettes. We were first to bring high technology to a higher level of quality.

So ask for an Elite One, Two, or Three. Because when it comes to disk drives, nobody uses their head like Rana.

NOW AVAILABLE FOR THE APPLE III. . .
THE ELITE TWO.THREE AND ELITE THREE.THREE

RanaSystems



21300 Superior St., Chatsworth, CA 91311 (213) 709-5484. For dealer information call toll free: 1-800-421-2207. In California only call: 1-800-282-1221. Source Number: TCT-654

Available at all participating Computerland stores and other fine computer dealers.

100%

CERTIFIED ERROR FREE



Guaranteed
when properly
used to
Read, Write
Error-Free as long
as you
own them.

Sentinel Computer Products, Division of Packaging Industries Group, Inc.

QUALITY YOU MAY NEVER NEED. But it costs no more!

The expert technicians who produce and monitor the quality of our diskettes have developed new state-of-the-art technology using equipment we design and build ourselves, unlike any other diskette maker. That's why our burnishing method uses a unique, dual-sided technique which provides an advanced degree of surface smoothness, the key to consistent high quality



SENTINEL®

The Professional's Diskette — Ideal for Personal Use.

performance. In addition, a superior, high quality lubricant assuring extra long life and a quality control program which includes certifying every Sentinel Diskette are reasons we can offer you the industry's most exacting guarantee. For unsurpassed information security, choose Sentinel brand, and ask your dealer about the new 2-PACK In a resealable storage case.

Sentinel Computer Products, Division of Packaging Industries Group, Inc.,
Hyannis, MA 02601 Tel: 617-775-5220

www.americanradiohistory.com

Letters

would welcome any response Radio Shack might be willing to offer on the performance of its Model 16.

Sam Harp

Marvin Stone

Oklahoma State University

Department of Agricultural Engineering

Agricultural Hall, Room 227

Stillwater, OK 74078

Thank you for the opportunity to respond to the letter by Sam Harp and Marvin Stone of the Department of Agricultural Engineering at Oklahoma State University.

We have studied the benchmark tests as submitted by OSU, and we do not substantially disagree with the timings of the tests for the TRS-80. The tests appear to make a Model II running a BASIC program under TRSDOS a faster machine than a Model 16 running TRSDOS-16 or a Model 16 running TRS-Xenix.

As with all benchmark tests, it is appropriate to say that the particular program used has much to do with the timed results. Benchmark #1 is a straightforward BASIC program that evaluates the sine of an expression containing one numeric variable raised to the power of a second variable and repeats this 1000 times. In Model II BASIC, both the exponentiation and the SIN function are evaluated with single precision only, there being no other possibility. In MBASIC for TRS-Xenix, the same functions are evaluated with double precision only, there being no possibility of performing any math routine at any other precision. So we have the situation where identical syntax typed into the two BASICs will give comparisons of speed for that program, but the two programs are radically different internally.

Radio Shack was pleased to be able to offer the Decimal Math Pack as an integral part of TRS-Xenix MBASIC. This removes the "rounding errors" that are an inevitable part of Model II BASIC; of course, this newfound "accuracy" has been at the expense of the speed of some functions, particularly trigonometric functions such as SIN. The BCD (binary-coded decimal) math routines are one of the many ways in which we believe we have been able to provide a superior performing BASIC. But this does not mean that all math is slower because it is in double precision; in fact, a minor variation of the OSU benchmark (using any of the four standard arithmetic operators instead of exponentiation and the SIN function)

← Circle 417 on inquiry card.

Teletek's New Combo Could Make You A Hero!

The SBC-II could be just the right ingredient for your latest concoction. The newest member of Teletek's family of multi-user, multi-processing S-100 products, the SBC-II essentially combines, or "sandwiches" two Teletek SBC-I's into one board. The SBC-II provides the capability to support two users from one standard size IEEE-696/S-100 slave board.

The SBC-II maintains full performance for each user with an independent CPU (Z80A or Z80B), 64K RAM, Serial I/O, and FIFO communications port to the system master. The system integrator benefits by getting complete support for two users for the price of one board.

TurboDOS and MDZ operating systems will support combinations of SBC-I's and SBC-II's offering system design efficiency and flexibility never before possible.

If you're hungry for value and efficiency, order an SBC-II from Teletek. You'll love every byte.



TELETEK

4600 Pell Drive
Sacramento, CA 95838
(916) 920-4600
Telex 4991834 TELETEK
Dealer inquiries invited.

© Teletek 1983
Circle 464 on inquiry card.

Letters

will run faster on Xenix than on the Model II.

Program mixes containing a substantial proportion of trigonometry will run slower than a program containing little or no trigonometry in either BASIC, and this time differential will be greater on MBASIC than on Model II BASIC. OSU's Solar Energy Benchmark program contains a substantial proportion of trigonometric functions.

Philip S. Hurrell

Radio Shack Computer Customer Service
400 Atrium-One Tandy Center
Fort Worth, TX 76102

Program

```
230 **** MODEL 16 (TRS-XENIX) . . . . 132.0
240 A=3.14159
250 B=3/7
260 FOR I=1 to 1000
270 Z=SIN(A-B)
280 NEXT I
```

Table 1:

BENCHMARK #1
EXECUTION TIME SECONDS

IBM PC (MS-DOS)	29.0
OSBORNE (CP/M)	43.0
MODEL II (TRSDOS)	43.0
APPLE II	75.0

Table 2:

BENCHMARK #2
EXECUTION TIME SECONDS

IBM PC (PC-DOS)	358
OSBORNE (CP/M)	379
MODEL II (TRSDOS)	429
MODEL 16 (TRS-XENIX) ONE USER	677
MODEL 16 (TRS-XENIX) TWO USERS	1316

Editor's note: the program for Benchmark 2 is an average BASIC program of 130 lines; due to lack of space, it is not included here. . . . G.W.

Commodore 64 Comments

I must comment on several points raised in your review of the Commodore 64 (July, page 232).

First, I don't know what the obsession is with repeating keys. If you want *all* keys to repeat, then a POKE 650, 128 will do the trick. A POKE 650, 0 will cause only the normal keys to repeat.

Second, it is true that you can enter most keywords with two keys (usually the first letter and the shifted second letter). However, only the screen editor shows this coded form—any listed program prints the full word. When working with the screen editor, switching to the upper/lower character set (press the Commodore and shift keys at the same time) will figure the code in a more readable form. For example, POKE 650, 0 would appear as "pO 650, 0". I use this feature quite often for the PRINT# keyword ("pR"). This saves typing the word PRINT and the shifted 3 for the # character.

Third, the disk is awkward in some areas, but I feel your selection of the directory display was a poor choice. After running the WEDGE program, the directory can be displayed by typing "@\$". Note that it is displayed—not loaded—with this command. Is this any more awkward than booting the disk and typing "CATALOG" on an Apple? You also state that because of the side sectors, a relative file fills the entire disk. This is not true—you should say that a relative file *can* fill the entire disk. Many small relative files can be put on one disk.

You should have been more critical

The Most Promising Duet For An Orchestra.

**Our duet is perfect for a single user system.
The same duet performs even better in a multi-user orchestra.**

MCM ★ 80:

S-100 Single Board Computer ■ Single or multi processor capability ■ Programmable master or slave selection ■ Redundant processor manipulation ■ 4MHz Z80A or 6MHz Z80B CPU ■ 64K RAM and 2K EPROM with monitor ■ 2 serial, 2 parallel, 4 timer ports ■ Bi-directional inter-processor channel ■ Dual mode serial ports interface ■ Multi-layer PCB construction.

\$495.

Circle 240 on inquiry card.



DCM ★ 80: S-100 Disk Controller Module ■ 8" and/or 5 1/4" floppy disk controller ■ SASI (ANSI, SCSI) hard disk host adapter ■ Single and double density, single and double side ■ Software implementation on CP/M¹ 2.2 and TurboDOS²

¹ TM of Digital Research, Inc.
² TM of Software 2000, Inc.

\$345.



JC SYSTEMS

469 Valley Way
Millpitas, CA 95035
408-945-0318
TWX#910-381-7041



UDS gives 212 users three ways to go!

212A—Today's most popular modem. UDS offers a fully Bell-compatible unit with complete local and remote test capability. Select 0-300 or 1200 bps for full-duplex asynchronous communication. The UDS 212A is FCC certified for direct connection to the dial-up telephone network, and available in multi-channel, rack-mounted configuration.

SINGLE UNIT PRICE **\$595**

212 LP — Compatible with 212As at the 1200 bps, full-duplex asynchronous communication rate. No power supply or AC connection required; the 212 LP derives its operating power directly from the telephone line. Ideal for applications requiring 212A capability at 1200 bps only. The 212 LP is direct-connect certified.

SINGLE UNIT PRICE **\$445**

212A/D — Identical to the 212A, with automatic dialing capability added! The unit stores and dials up to five 30-digit numbers. CRT menu prompting, single-stroke commands and automatic test capabilities are provided. The 212A/D is direct-connect certified.

SINGLE UNIT PRICE **\$645**



Universal Data Systems



MOTOROLA INC.
Information Systems Group

5000 Bradford Drive, Huntsville, AL 35805. Telephone 205/837-8100; TWX 810-726-2100

DISTRICT OFFICES:

Old Bridge, NJ, 201/251-9090 • Blue Bell, PA, 215/643-2336 • Atlanta, 404/998-2715 • Chicago, 312/441-7450 • Columbus, OH, 614/895-3025 • Boston, 617/875-8868
Richardson, TX, 214/680-0002 • Englewood, CO, 303/694-6043 • Houston, 713/988-5506 • Tustin, CA, 714/669-8001 • Mountain View, CA, 415/969-3323

Circle 492 on Inquiry card.

Created by Dayner/Hall, Inc., Winter Park, Florida



PeachText
5000



In a word, a star is born.

PeachText 5000™ has arrived. A complete personal productivity system for word processing, financial modeling, mailing lists and simple data-base management. All at one price—\$395.00. And all from Peachtree Software Incorporated.

The quality is unmistakably Peachtree: proven, powerful applications with menu-driven features, easy-to-use documentation and quick access to “Help” prompts. And they’re fully interactive.

PeachText 5000 is available for the IBM Personal Computer,™ the COMPAQ Portable Computer,™ the Texas Instruments Professional Computer™ and the Zenith Z-100.

The PeachText 5000 Personal Productivity System includes:

1 Word processing

PeachText™ word processor. PeachText has long been recognized as one of the best in the industry, with sophisticated print capabilities second to none and complete editing capabilities for creating and manipulating a variety of documents. We’ve made it even better for PeachText 5000.

We’ve even installed the Random House Electronic Thesaurus™ in PeachText.

Spelling Proofreader. This high-performance package can check a 10,000-word document for spelling and typographical errors in less than two minutes.*

2 Financial planning

Turn your computer’s memory into a worksheet for financial and other mathematical analysis. PeachCalc™ will address up to 256K of RAM, so you don’t have to worry about your memory space outstripping PeachCalc’s capacity. Combine spreadsheets with PeachCalc’s merge functions or insert PeachCalc reports

into PeachText documents. You can even use the “Execute” command to set up material from PeachText or other files to be fed into PeachCalc.

3 Data management

List Manager. This module uses Peachtree’s state-of-the-art screen manager and index file manager to give you complete control over the design and use of mailing lists, labels and other files or reference aids. Output can be used with the PeachText word processor to individualize form letters or template documents.

5000 applications. And you get file converter programs to make existing WordStar,® Easy Writer™ and VisiCalc™ files usable with PeachText 5000—because you shouldn’t have to suffer because you’ve waited this long for the complete personal productivity system.

Free 30-day support from Peachtree Software Incorporated, on return of the registration card.

PeachText 5000 is here. The complete personal productivity system. And it’s unmistakably Peachtree.

Circle 353 on inquiry card.

*In actual trials using an IBM Personal Computer and 320K diskettes, Spelling Proofreader checked a 10,024-word document in one minute and 15 seconds, using the standard 20,000-word dictionary supplied with the package. Checking times may vary depending on your hardware.

Limited Time Introductory Offer

Now PeachText 5000 is available for \$395.00. That’s right—just \$395.00.

And that’s not all. With your PeachText 5000 package you will receive:

A free box of 10 Peachtree/Wabash 5¼” diskettes to hold the fruits of your new Peachtree productivity.

A coupon to get Peachtree’s “Access Pak” for \$10.00. The Access Pak, which has a retail value of \$525.00, includes Information Access, which allows you to extract information from Peachtree accounting products for use with PeachText



WordStar is a trademark of MicroPro International Corporation.
Easy Writer is a trademark of Information Unlimited Software.
VisiCalc is a trademark of VisiCorp.
Random House Electronic Thesaurus is a trademark of Random House Inc.

Unmistakably Peachtree



Who are the dealers in my area?

Name: _____
Company: _____ Telephone: _____
Address: _____
City: _____ State: _____ Zip: _____

© 1983 Peachtree Software Incorporated an MSA company
3445 Peachtree Road, N.E./8th Floor/Atlanta, Georgia 30326/1-800-554-8900

BYT 10/83

SERIAL PORT EXPANDER AND MORE



BTA's MODEL 524 MULTI-PORT CONTROLLER is a code activated one to four serial port expander — but that's not all since it has separate and independent UARTS, buffers and handshaking each port can operate with a different configuration, i.e. different baud rates, stop bits, etc. These features also permit two or more devices to communicate with the 524 simultaneously.

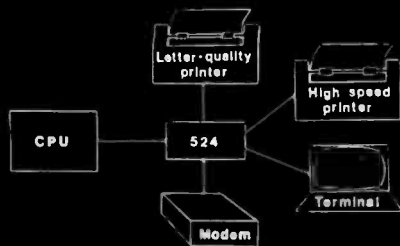

Full duplex with EIA RS-232 protocol

Baud rates up to 19,200

Expansion to 16 ports by cascading

Peripheral ports may be configured by user software

One year warranty



- **MODEL 524** \$249.00
- **MODEL 524A** \$279.00
same as model 524 except has 256 byte rx/tx buffers per port
- **MODEL 524 D** \$269.00
same as model 524, plus continuous polling of each peripheral device for data transfer requests. The device is automatically connected when its turn comes up. ON, BUSY and OFF messages are sent to the peripheral device.
- Other models available — Contact us or your dealer for additional information.

BTA BAY TECHNICAL ASSOCIATES, inc.
HIGHWAY 603, P.O. BOX 387
BAY ST. LOUIS, MISSISSIPPI 39520
16011467-8231

Letters

about the poor quality (or quality control, perhaps) of the RF modulator. Of four TV sets, my Commodore 64 works on only two. Nothing is said in the *User's Guide* about any adjustments that can be made. After a few months of using the *User's Guide* and the *Programmer's Reference Guide*, some of my pages are ready to fall out. I think this is due to the small size of the bindings.

James E. Borden
641 Adams Rd.
Carlisle, PA 17013

Two on Logo

I must applaud Gary Kildall and David Thornburg for "Digital Research's DR Logo" (June, page 208). For the last year and a half, I have been trying to convince school and college administrators that Logo is a powerful, general-purpose programming language. Before Logo was available on microcomputers, I taught college and teacher-in-service courses in BASIC. The most common myth about BASIC is that the relatively few primitive operations make it easy to learn. This is believed by those who have never tried to teach BASIC to neophytes. Most first-time users complain about the pickiness of the interpreter regarding misplaced quotes or semicolons, and numerous other things. Some adults I've taught even confuse PRINT and INPUT. Considering that these two statements do opposite things, one begins to wonder if BASIC is easy to learn.

When comparing languages, I always stay away from evaluating specific features of a language, such as whether or not it supports pointer-type variables, Boolean operators, or whatever. The real issue is this: how easy is the language to think in? The metaphor Logophiles often use for the activity of programming is that it is like teaching the computer (or turtle) a new word. More than just a metaphor, this changes your perspective on solving the problem. The fact that people can have personalized input and define their own words gives them a sense of power over the machine and helps them view the computer as a mental aid. This results in less blame being placed on the machine for an incorrect result because the user is the one that created the procedure. The ability to create your own keywords encourages you to say to yourself, "How can I break this task up into chunks that are suitable for keyword

definitions?". Of course, it isn't necessary to break the problem up into chunks. The example I often use in Logo courses, drawing stickmen, comes from *Mindstorms*, pages 100-103. Granted, drawing stickmen may be a trivial task on the outside, but most people adopt this structured approach because the solution is easier to visualize, easier to think through, and easier to debug, if necessary.

Obviously, I think Logo is an easier language to think in than BASIC. The adults and children I have taught Logo to over the past two years agree. They also agree that Logo is a powerful language. Logo is a dialect of LISP, which, as Kildall and Thornburg put it, "is a powerhouse of a language."

But there is more at stake here than semicolons and quotation marks. Kildall and Thornburg say that Logo demystifies artificial intelligence (AI) and puts AI into the hands of many. This is extremely important. Expert systems and other contributions from AI will greatly affect the way we use computers and will turn the computer into a thinking tool, not one that just crunches numbers very quickly. The impact that a thinking tool will have on society as a whole must be dealt with, and to discuss it intelligently one should understand the ways and means of artificial intelligence (i.e., its theories and its languages).

So wake up, you BASIC fans. LIST is more than just a command that prints out your program.

K. Sharman
42 Rossmere Close SE
Medicine Hat, Alberta
T1B 2J8, Canada

Request for Help

I am looking for a 12-inch green-screen monitor or terminal with shielding to allow use by individuals with special inner ear problems.

The medical problem I refer to allows certain people to hear some normally inaudible high frequencies apparently generated by the horizontal sweep circuits in all televisions and CRT monitors used for computer displays. These frequencies are both heard and felt within the inner ear, resulting in physical nausea, loss of equilibrium, and other related physical and mental distress.

In local experiments with such people, assorted wrapping of some monitors in foam or placing them on foam pads par-

Introducing the Most Powerful Business Software Ever!

TRS-80™ (Model I, II, III, or 16) • APPLE™ • IBM™ • OSBORNE™ • CP/M™ • XEROX™



The VERSABUSINESS™ Series

Each VERSABUSINESS module can be purchased and used independently, or can be linked in any combination to form a complete, coordinated business system.

VERSARECEIVABLES™ \$99.95

VERSARECEIVABLES™ is a complete menu-driven accounts receivable, invoicing, and monthly statement-generating system. It keeps track of all information related to who owes you or your company money, and can provide automatic billing for past due accounts. VERSARECEIVABLES™ prints all necessary statements, invoices, and summary reports and can be linked with VERSALEDGER II™ and VERSAINVENTORY™.

VERSAPAYABLES™ \$99.95

VERSAPAYABLES™ is designed to keep track of current and aged payables, keeping you in touch with all information regarding how much money your company owes, and to whom. VERSAPAYABLES™ maintains a complete record on each vendor, prints checks, check registers, vouchers, transaction reports, aged payables reports, vendor reports, and more. With VERSAPAYABLES™, you can even let your computer automatically select which vouchers are to be paid.

VERSAPAYROLL™ \$99.95

VERSAPAYROLL™ is a powerful and sophisticated, but easy to use payroll system that keeps track of all government-required payroll information. Complete employee records are maintained, and all necessary payroll calculations are performed automatically, with totals displayed on screen for operator approval. A payroll can be run totally, automatically, or the operator can intervene to prevent a check from being printed, or to alter information on it. If desired, totals may be posted to the VERSALEDGER II™ system.

VERSAINVENTORY™ \$99.95

VERSAINVENTORY™ is a complete inventory control system that gives you instant access to data on any item. VERSAINVENTORY™ keeps track of all information related to what items are in stock, out of stock, on backorder, etc., stores sales and pricing data, alerts you when an item falls below a preset reorder point, and allows you to enter and print invoices directly or to link with the VERSARECEIVABLES™ system. VERSAINVENTORY™ prints all needed inventory listings, reports of items below reorder point, inventory value reports, period and year-to-date sales reports, price lists, inventory checklists, etc.

VERSALEDGER II™ \$149.95

VERSALEDGER II™ is a complete accounting system that grows as your business grows. VERSALEDGER II™ can be used as a simple personal checkbook register, expanded to a small business bookkeeping system or developed into a large corporate general ledger system without any additional software.

- VERSALEDGER II™ gives you almost unlimited storage capacity (300 to 10,000 entries per month, depending on the system),
- stores all check and general ledger information forever,
- prints tractor-feed checks,
- handles multiple checkbooks and general ledgers,
- prints 17 customized accounting reports including check registers, balance sheets, income statements, transaction reports, account listings, etc.

VERSALEDGER II™ comes with a professionally-written 160 page manual designed for first-time users. The VERSALEDGER II™ manual will help you become quickly familiar with VERSALEDGER II™, using complete sample data files supplied on diskette and more than 50 pages of sample printouts.

SATISFACTION GUARANTEED!

Every VERSABUSINESS™ module is guaranteed to outperform all other competitive systems, and at a fraction of their cost. If you are not satisfied with any VERSABUSINESS™ module, you may return it within 30 days for a refund. Manuals for any VERSABUSINESS™ module may be purchased for \$25 each, credited toward a later purchase of that module.

To Order:

Write or call Toll-free (800) 431-2818
(N.Y.S. residents call 914-425-1535)

- * add \$3 for shipping in UPS areas
- * add \$4 for C.O.D. or non-UPS areas

- * add \$5 to CANADA or MEXICO
- * add proper postage elsewhere

DEALER INQUIRIES WELCOME

All prices and specifications subject to change / Delivery subject to availability.

COMPUTRONICS

50 N. PASCACK ROAD, SPRING VALLEY, N.Y. 10977

* TRS-80 is a trademark of the Radio Shack Division of Tandy Corp. - *APPLE is a trademark of Apple Corp. - *IBM is a trademark of IBM Corp. - *OSBORNE is a trademark of Osborne Corp. - *CP/M is a trademark of Digital Research - *XEROX is a trademark of Xerox Corp.

tially attenuates the high-frequency noise or sound, but not enough to permit the individual to use the installation in an office environment. There is also the problem of reducing the circulation of cooling air through the equipment.

Have other readers run into this problem, perhaps? We would appreciate hearing from anyone who has any suggestions, solutions, monitors, or computer terminals with effective shielding (sound, electromagnetic, or both) for dealing with this problem.

John R. Page, Pastor
Trinity Bible Church
828 Pennsylvania Ave.
Medford, OR 97501

**OK Modem Tariff
Not Okay**

I am writing in regard to a serious problem that modem users in the state of Oklahoma are facing.

Southwestern Bell Telephone Company's Oklahoma tariffs call for the charging of an "Information Terminal Service"

rate for anyone connecting a computer to the telephone lines via a modem.

This rate is approximately 500 percent higher than the standard residential base rate. The present residential rate is around \$9 per month. If you connect a computer to the line with a modem, even if you only call Compuserve once a month, the rate jumps to a whopping \$45.90. The additional charge for Touch-Tone service also increases, from \$1.25 to \$3.50 per month. This will undoubtedly increase dramatically if Bell gets the \$301,000,000 increase that it just applied for with the Oklahoma Corporation Commission.

Obviously, this tariff dramatically affects the entire industry, as the tariff for all practical purposes prohibits noncommercial, hobbyist modem use. And if Bell is permitted to get away with the enforcement of the tariff (as it is now beginning to), a precedent will be set for other local operating companies to follow in other states.

Apparently, Bell is just now beginning to apply this 1965 tariff to noncommercial modem and computer users. And although Bell representatives have fallen back on the age of the tariff as an excuse,

they have no intention of exempting residential modem use from the provisions of the tariff.

Therefore, the Oklahoma Modem Users Group (OMUG) is fighting Southwestern Bell and its unfair tariff. We are doing this through media attention, responsible organization, and speaking at Corporation Commission hearings. If all else fails, we will institute legal action to attempt to force a change in the tariffs.

Because of the national attention this issue is just now beginning to attract and the fact that we desperately need more support, we have taken several steps to ensure that people are informed. We have a mailing list, and we send out a biweekly newsletter covering the latest updates on the tariff situation. We have also established a 24-hour hot line that is updated daily with a one- to three-minute recorded announcement; the number is (405) 360-7462.

Robert Braver, President
Oklahoma Modem Users Group
911 West Imhoff Rd., #634
Norman, OK 73069 ■

256K Byte Ram Board for IBM PC or XT
DIP SWITCH ADDRESS SELECTABLE ON ANY 64K BOUNDARIES.
WITHOUT RAM - \$189.95 - No. 11010
AVAILABLE INSTALLED WITH:
64K - \$229.95 - No. 11011
256K - \$349.95 - No. 11014

Parallel Printer Adapt. for IBM PC or XT
MAY BE USED AS A GENERAL PURPOSE I/O PORT.
12 BUFFERED TTL OUTPUTS.
5 TTL LATCHED TTL INPUTS. BUFFERED SOFTWARE PROGRAMMABLE INTERRUPTS. RESET TARGET PERIPHERAL / DEVICE WITH SYSTEM / I/O SHELL STANDARD FOR I/O.
PART No 21020 - \$89.95

NEW for IBM!

PC WARE, INC.
Dept. B
4883 Tonino Dr.
San Jose, CA 95136
(408) 978-8626

PC WARE
PERSONAL COMPUTER

TO ORDER In USA shipping paid by us for orders pre-paid. We accept C.O.D. orders (U.S. only). For VISA or MASTERCARD shipping charges will be added. CA residents add 6.5% for tax. Outside USA add 15% for shipping and handling. Payment must be in U.S. currency. Dealer inquiries invited.

VISA

Free Genius In Every Box.

At **CompuPro**, we put a little genius into each of our systems. Maybe it's our dual processor that handles both 8-bit and 16-bit software concurrently. Or another **CompuPro** first, M-Drive/H,TM the board that does the work of a disk drive—only faster.

In every case you can get model-to-model expandability, six processors to choose from, 12- to 36-month product warranties and nationwide on-site service from the Xerox[®] Service Group.

For performance, quality and reliability at a cost-effective price, try **CompuPro's** System 816 family of high-performance computers today.

Let *our* genius multiply *your* genius.

Model A. Single-user, expandable to multi-user. Includes dual processor, 128 Kbytes of static RAM, four serial ports, CP/M[®] 8-16TM SuperCalc-86TM dBase IITM Hyper-TyperTM and Field CompanionTM M-DriveTM software is also included.

Model B. Ultra-high performance single or multi-user. Includes dual processor, 256 Kbytes of static RAM, nine serial ports, same software as Model A, plus MP/MTM 8-16TM.

Model C. Our top-of-the-line multi-user microcomputer. Supports as many as seven user workstations as well as a complete complement of peripherals. Includes 512 Kbytes of static RAM, nine serial ports, same software as Model B. Bundled with on-site service from Xerox Service Group.

Model 86/87. For high-speed multi-user applications. Uses the fastest CPU on the market (the 10MHz 8086). In addition, 1.5 Mbytes of solid state disk memory give as many as five users access to 16-bit software up to 35 times faster than disk-based systems. Includes 512 Kbytes of 16-bit memory, CP/M-86[®] MP/M-86TM SuperCalc-86 and SuperWriter-86TM plus Xerox service.

Model 68K. A single-user computer that optimizes the powerful new CP/M-68KTM operating system. Delivers ultra-high speed for those who develop their own programs. Includes 256 Kbytes of 16-bit memory, 1.5 Mbytes of M-Drive/H, CP/M-68K, mapFORTH and C languages, as well as Xerox service.

All basic **System 816** configurations provide as much as 4.8 Mbytes of floppy disk storage, and are expandable to 1 Mbyte or more of RAM and as much as 4 Mbytes of M-Drive/H. They all have convenience features such as clock/calendar, interrupt controllers, interval timers, and optional math processors. Programming languages available from **CompuPro** include Assembler, BASIC, Pascal, PL/1 and COBOL, as well as the new ANSI FORTRAN 77TM from Digital Research.



For your business, industrial and scientific computing solutions, call (415) 786-0909, ext. 206 today for the location of the **Full Service CompuPro System Center** nearest you.

CP/M and CP/M-86 are registered trademarks and CP/M-68K, MP/M-86 and FORTRAN 77 are trademarks of Digital Research. Xerox is a registered trademark of the Xerox Corporation. CP/M 8-16 and MP/M 8-16 are compound trademarks of Digital Research and CompuPro. SuperCalc-86 and SuperWriter-86 are trademarks of Sorcim. dBASE II is a trademark of Ashton-Tate. Hyper-Typer is a trademark of Summit Software Corp. Field Companion is a trademark of Gensoft Corp. M-Drive and M-Drive/H are trademarks of CompuPro.

Dealer inquiries invited



CompuPro, a **600BOUT** Company

3506 Breakwater Court, Hayward, CA 94545

Circle 99 on inquiry card.

DIMENSION. THE MOST COMPATIBLE COMPUTER YOU CAN BUY.

Introducing the capability the world has been waiting for. A single personal computer able to handle Apple, IBM, TRS-80, UNIX and CP/M-based software.

The Dimension 68000 Professional Personal Computer does it all. It actually contains the microprocessors found in all of today's popular personal computers. And a dramatic innovation creates the environment that lets these systems function merely by plugging in the software.

Add to this the incredible power of a 32 bit MC 68000 microprocessor with up to 16 megabytes of random access memory. You have the machine that easily meets today's needs. And tomorrow's. It's the only practical way to upgrade without the need to recreate your data base.

Dimension. At about the same price as the IBM PC, it's obviously the best value you can find. For more information ask your dealer or call us at (214) 630-2562.

dimension



A product of Micro Craft Corporation, 4747 Irving Blvd., Suite 241, Dallas, Texas 75247. ©1983
Apple is a registered trademark of Apple Computer, Inc.; IBM is a registered trademark of International Business Machines Corporation; TRS-80 is a registered trademark of Radio Shack, a Tandy Corporation company; UNIX is a trademark of Bell Laboratories, Inc.; CP/M is a registered trademark of Digital Research Corporation.

Circle 301 on Inquiry card.

MOST POWERFUL, E PERSONAL



The HP 150

Magic is the code name for Hewlett-Packard's personal-computer project in Sunnyvale—and it fits. Something magical happens when you use the HP 150. The optical touchscreen trademarked as HPTouch goes beyond other pointing devices; it makes you feel that you have remarkable powers in your fingertips. It's almost as if the touchscreen turns your finger into a conduit between your mind and the computer.

Hardware: Compact, Powerful, and Innovative

This compact machine packs the system-processor unit, memory, video-display unit and control circuitry, three I/O (input/output) ports, and touchscreen electronics into an elegant package that is 1-foot square. Two free-expansion slots permit a network-interface board and expansion to 640K bytes of RAM (random-access, read/write memory). An optional user-installable thermal printer fits in an enclosure at the top of the unit, with its own connecting cable. The dual-floppy-disk unit contains two single-sided Sony 3½-inch disks holding 270K bytes each and has a footprint not much larger than the main unit's. The HPIB bus used to connect the disk drives permits the controller to reside with the drives; no expansion slots are required to add additional floppy or hard disks.

The compactness of the HP 150 does have one drawback for personal-computer users who do intensive computation. There was no way to squeeze a socket in for an 8087 co-processor. Early indications are that the HP 150 will be an open system with respect to both hardware and software, and perhaps someone will develop an 8087 board for one of the two expansion slots.

Photo 1 shows the back of the HP 150 with its various I/O connectors.

In photo 2, part of the back of the system has been removed to expose the two expansion slots, one of which is occupied by a memory board. Photo 3 shows the system with the back removed. The motherboard sits one level above the two expansion slots and holds its own piggyback 256K-byte memory board. Above that, you can see the video-controller board. Photo 4 shows the system from the front with the bezel removed and turned around to face the camera.

The bezel contains the touchscreen electronics—the grid of light-emitting diodes and photo diodes. There are 24 holes in each side of the bezel and 40 holes in both the top and the bottom. This provides touch sensitivity for each row of the display and for each unit of two columns.

The touchscreen leaves no doubt that the HP 150 intends to deliver the power of personal computers to more people—nontechnical people. For HP, always known as an outstanding manufacturer of high-performance products for engineers, the 150 signals a bold entry into the broader market now dominated by IBM and Apple. Cyril Yansouni, general manager of HP's new personal computer division, confirms this interpretation and describes the 150 as the first of a new family of products. Yan-

souni also says that the HP 150 will be priced competitively, another departure for the company. A standard system with 256K bytes of RAM and two Sony 3½-inch disks providing 540K bytes of storage, MS-DOS, the Personal Applications Manager software, and Microsoft BASIC will retail for approximately the same price as the IBM PC with equivalent memory and mass storage. The HP 150's unique touchscreen and user interface provide the magic in an already powerful computer.

High Performance

Hewlett-Packard's engineers did not forsake their reputation for building high-performance products when they designed the 150. The HP 150's 8088 runs at 8 MHz compared to the usual 5 MHz or less, and the standard amount of dynamic RAM is 256K bytes. There are also 6K bytes of static RAM for the screen and 160K bytes of ROM (read-only memory), bringing the total memory for the standard machine to 422K bytes. One of the two standard RS-232C serial-communications ports also serves as a higher-speed RS-422 port, and several peripherals can be daisy-chained off the HPIB connector, permitting high-capacity mass storage.

Hewlett-Packard makes some magic
by Phil Lemmons and Barbara Robertson



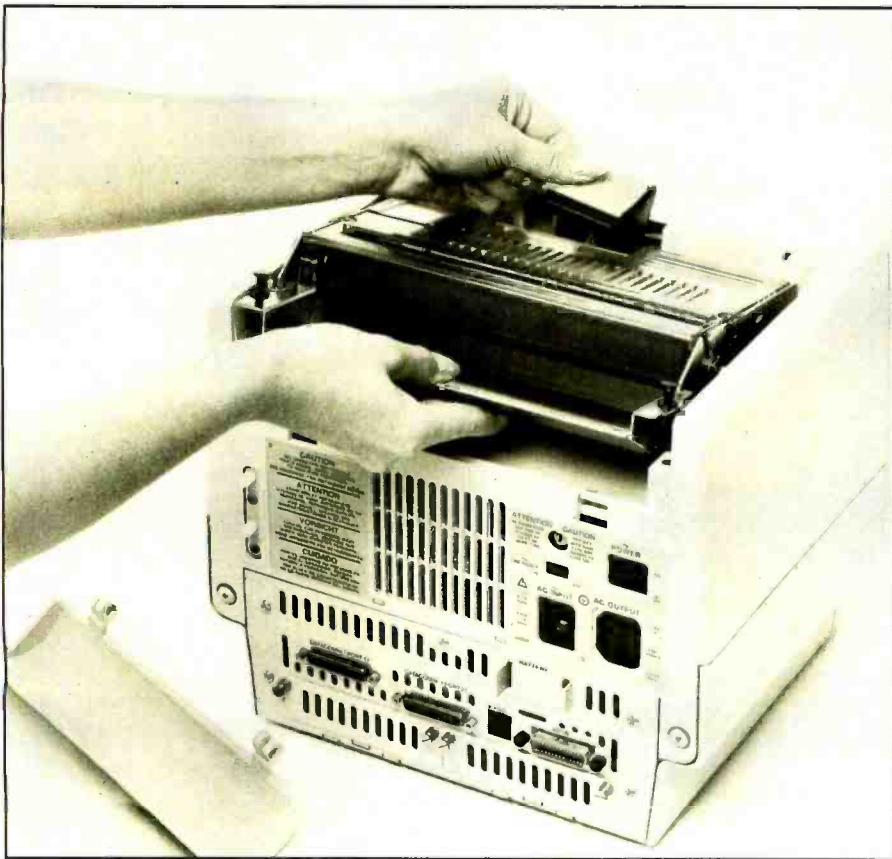

Photo 1: A back view of the HP 150. Note the two serial ports (DATA COM1 and DATA COM2), the port for HP-IB bus (used to connect a series of disk drives and parallel printers), and the easily removed battery.

Hewlett-Packard plans to introduce the HP 150 at the November Comdex show in Las Vegas and is already working with its dealers to provide all necessary support for that introduction, including major television and print advertising campaigns. According to Cyril Yansouni, general manager of HP's personal computer division, the company is establishing Personal Computer Centers for training dealers and end users. While these centers will not sell equipment or software, a professional training and marketing staff will be available to answer questions, conduct seminars, and refer prospective customers to dealers. Twenty of these centers are already open and 65 additional centers, located worldwide, are scheduled for completion by the end of 1983. For more information on the availability of the HP 150, or the location of a Personal Computer Center, call (800) FOR-HPPC.

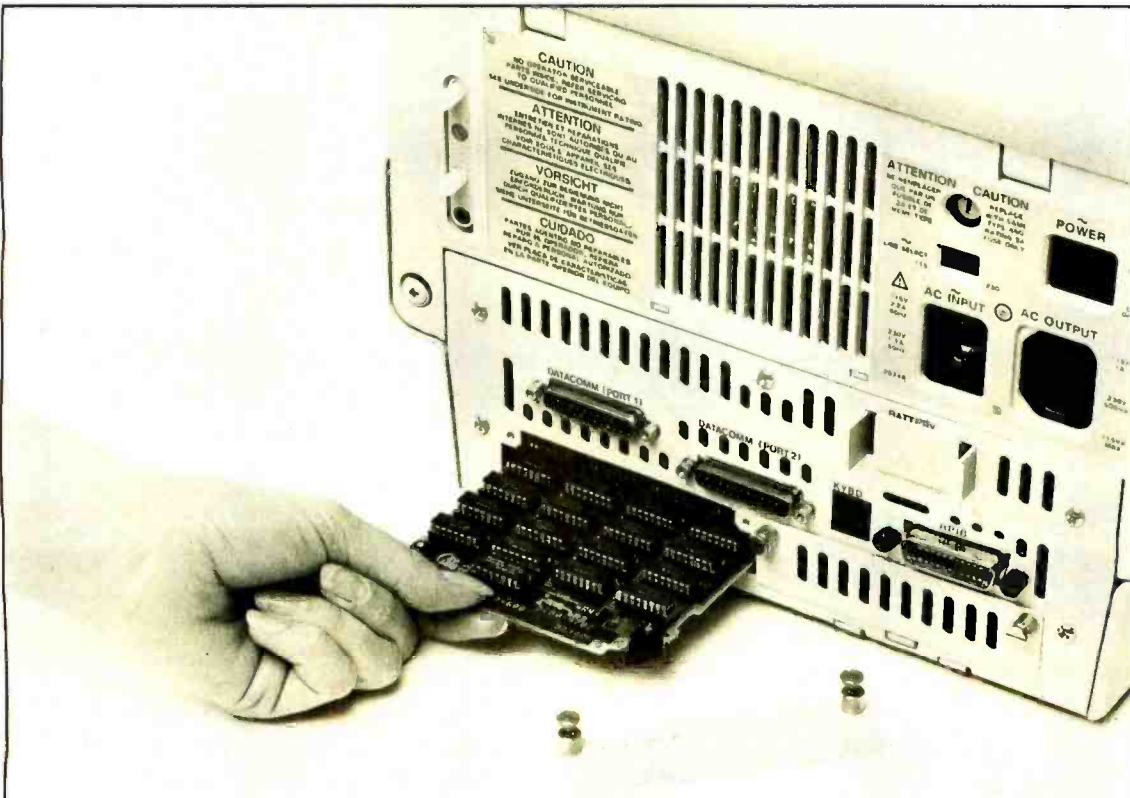

Photo 2: The HP 150 comes with 256K bytes of RAM. This photo shows an optional 256K-byte memory board in one of the two expansion slots.

Photo 5 shows the back of the 150 with its complement of I/O connectors and the optional thermal printer on top.

Available disk units include 5¼-inch and 8-inch floppy-disk drives as well as the 3½-inch disks, plus high-capacity Winchester disks. The Sony 3½-inch disks run at 600 rpm (revolutions per minute) rather than slowing down to the 300-rpm standard adopted by an ANSI committee.

The performance of the video display is also outstanding. The 9-inch screen looks too small until you turn it on. The "At a Glance" box on page 41 shows the HP 150 screen displaying essential facts about the system in a format similar to that of a card in the Personal Card File, an electronic Rolodex-like program available for the 150; a lot of information is displayed quite clearly on the 9-inch screen. With a resolution of 720 by 378 as an alphanumeric display and 512 by 390 as a bit-mapped graphics display, the green-phosphor screen

actually displays more pixels (picture elements) than the IBM PC 12-inch monochrome monitor, which has a 720 by 350 display. As an alphanumeric display, the HP 150's little screen provides 27 lines by 80 characters instead of the usual 24 by 80. Each character is formed by a 7 by 10 dot matrix in a 9 by 14 dot cell. The dots shift by half a dot to form clear characters, as the screen photos demonstrate.

The bottom line of the screen is reserved for system-status messages, and the two lines above that label screen areas programmed to perform specific commands when touched (softkeys). That leaves a full 24 by 80 screen plus the extra lines at the bottom for system enhancements.

Two controllers handle the video display. A custom gate array controls the graphics display, while the Standard Microsystems Corporation 9007 VPAC (Video Processor and Controller) takes charge of alphanumeric. As explained in "The CRT 9007

Video Processor and Controller" (April 1983 BYTE, page 96), the 9007 has powerful memory-addressing capabilities and flexible video-timing control. Its 30 registers include 12 to keep screen parameters and others for cursor control and light-pen operation. The 9007's memory-addressing power provides row-table-oriented memory addressing that relieves the system's central processor of the task of moving data on the screen.

The 9007 is partially responsible for the high performance of the HP 150's display in alphanumeric mode and for the gate array for the high-speed graphics, but systems software also plays an important role. Just as separate controllers control the two modes of the display, two separate software modules control screen I/O. The AIOS (alphanumeric input/output system) optimizes character I/O and the GIOS (graphical input/output system) optimizes bit-mapped graphical I/O. The GIOS includes routines for powerful graphics functions such as filling areas.

HP designed the keyboard on the assumption that people should be able to use the computer to its fullest without the touchscreen. The keyboard (see photo 6) has 107 sculpted keys, including cursor controls, editing keys, a numeric pad that can be shifted into a graphics-control pad, and eight programmable func-



Benchmark	HP 150	IBM
Empty Do Loops	6.13	6.43
Division	16.75	23.80
Subroutine Jump	11.80	12.40
MID\$ (substring)	19.33	23.00
Prime Number	151.60	190.00

Table 1: Benchmark results for the HP 150 against the IBM PC. The HP machine was running under MS-DOS 2.0, BASIC86, prerelease version 5.28. The IBM PC was running under PC-DOS 1.0, IBM BASIC. The benchmark programs are from "A Closer Look at the IBM Personal Computer" by Gregg Williams (January 1982 BYTE, page 36).

Photo 3: The motherboard holds a 256K-byte memory board on the left. The video-controller board is directly above the motherboard.

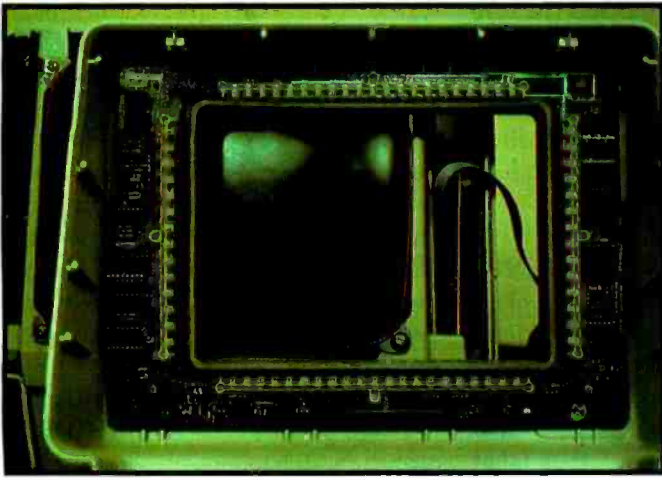

Photo 4: The inside of the touchscreen bezel with its light-emitting and photo diodes. The system recognizes a touch when an object breaks the light beams crossing the screen.

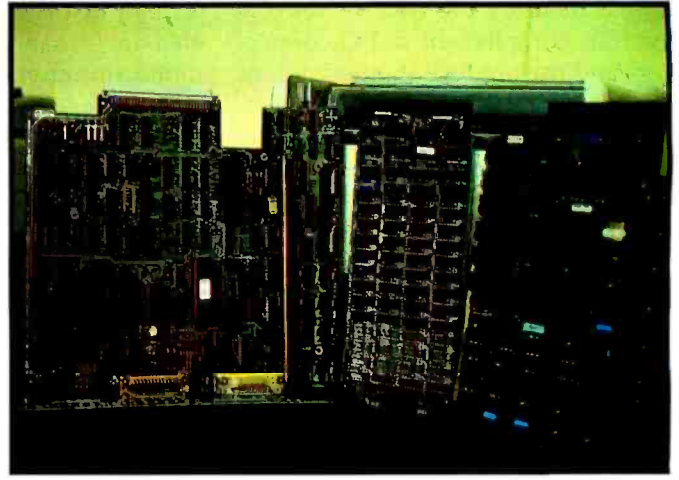

Photo 5: These boards—the motherboard, piggyback and expansion memory boards, and the video-controller board—are all packed into the tiny monitor. In addition, two boards, the CRT sweep and power-supply boards, stand on end on each side of the video screen.



Photo 6: The HP 150 keyboard.

At a Glance

Touch a tab in HP's Personal Card File program to look at a card at the card file.

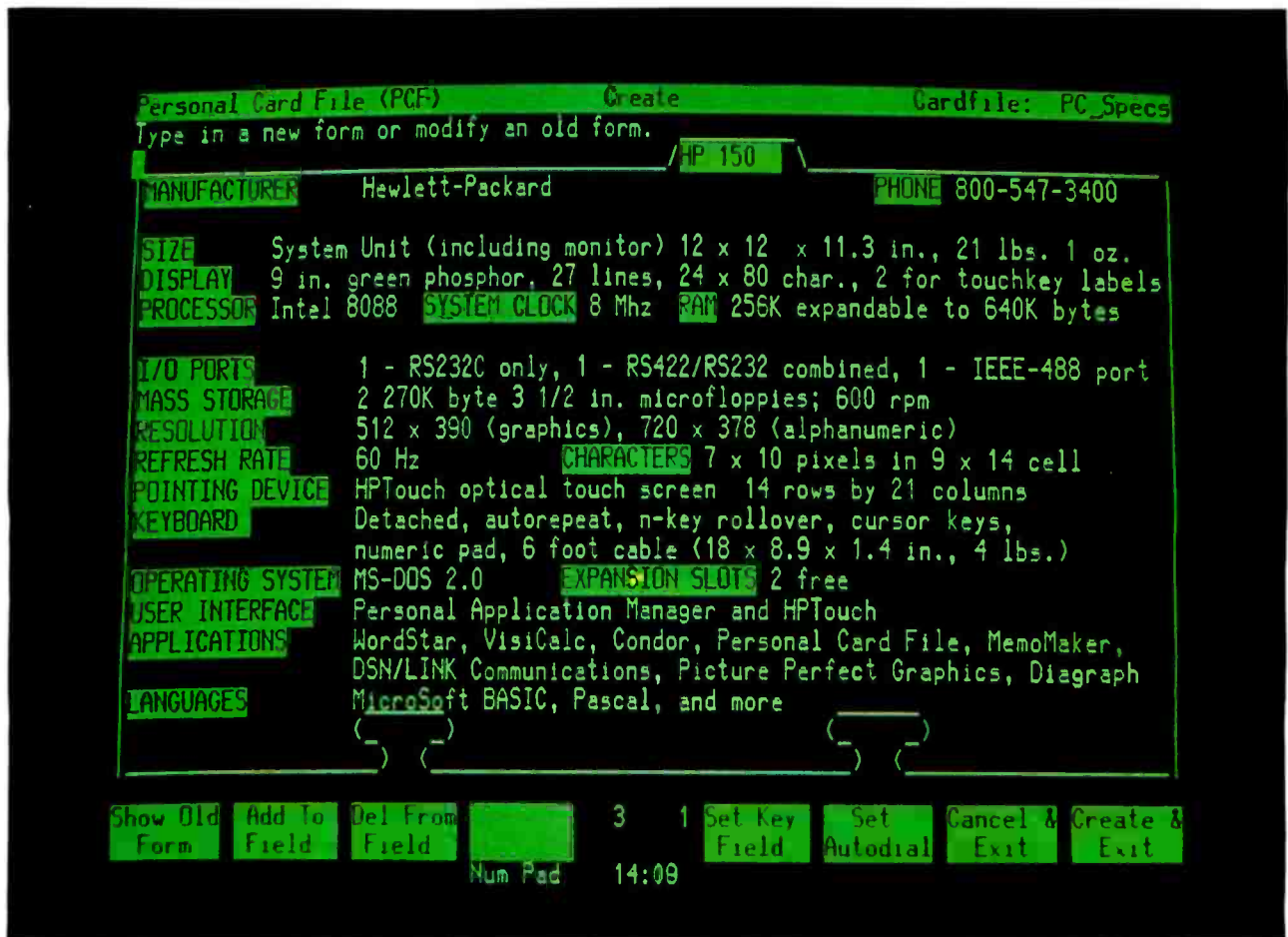
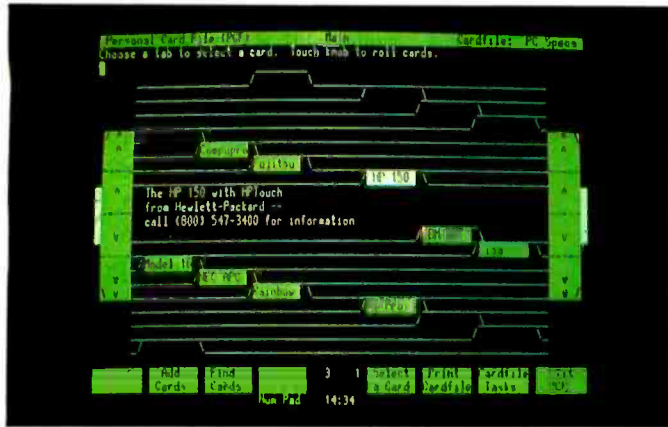

tion keys. The layout is excellent. This keyboard will be the standard keyboard for all HP machines and terminals for years to come. An 8041 processor located in the system unit controls both the keyboard and the touchscreen.

An NEC 7201 controls the serial ports with a Texas Instruments con-

troller chip handling the HPIB bus.

Both serial ports will operate at up to 19,200 bits per second (bps) as RS-232C ports and one will also operate as a higher-speed RS-422 port.

BASIC Benchmarks

Although it isn't possible to quantify the display's performance in this

product preview, we did try five of BYTE's interpretive BASIC computational benchmarks on the 150, running a prereleased version of Microsoft's BASIC86 version 5.28. Table 1 shows the results. Not surprisingly, the HP 150 did well. In the prime-number benchmark, the HP 150 outdistanced the IBM PC by 38

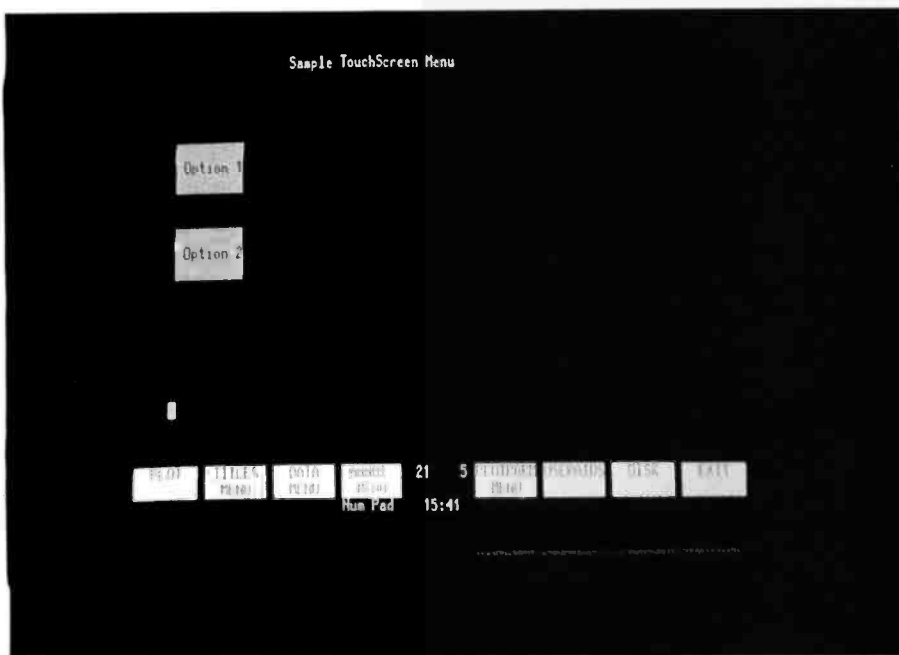

Photo 7: Options 1 and 2 can be selected by touch. A simple BASIC program created this menu (see listing 1).

seconds, even though the PC was running IBM PC BASIC, Microsoft's more advanced GW (Gee Whiz) BASIC, rather than BASIC86. The prereleased HP 150 was also significantly faster in the tests of division and string operations. The HP 150's 3½-inch disks performed well in simple disk I/O benchmarks—faster than all but a couple of the machines tested so far—but the results are not published here because HP plans to further improve the drives' performance.

Future products will expand the 150 family to include a compatible

portable and transportable unit as well as a version with color graphics. Plans call for enhancement of the 150 family with faster clocks and a more powerful processor. The 150 family will also be able to communicate with non-HP computers through an Ethernet-compatible networking scheme.

The Touchscreen and Compactness

You don't actually have to touch the screen to make the touchscreen work because the beams of light pass slightly above the surface of the

screen. One reason for choosing the optical touchscreen was to avoid coating the display screen with a material that would impair the sharpness of the display. Using a screen coat allows greater precision, but to take advantage of this precision you must point with a device much smaller than a fingertip. The smaller pointing devices seem to sacrifice the intuitive correctness of pointing with your finger.

While the 9-inch screen contributed to the compactness of the HP 150, it also reduced the size of the touch cells. You never have difficulty pointing to the defined touch areas at the bottom of the screen, or at the name of a file or program that you want to run, but a single character is difficult to select precisely. The cursor keys provide an easy alternative for fine movements, and pressing the select key selects the desired object.

The touchscreen also minimizes this problem in another way. The system recognizes a touch when your finger breaks the vertical and horizontal beams of light that cross above the object, and shows its recognition by displaying the object in inverse video. But a touch is not equivalent to a selection. The system only recognizes a selection when you withdraw your finger from the area and the interrupted light beams again cross the screen to the photo receivers under the bezel. You can move your finger around the screen for as long as you want, and the

A Potential User Looks at the Software

Phil Lemmons and I sat at his kitchen table late one night with the preview machine and prereleased copies of some of the software that Hewlett-Packard will offer for the HP 150. The touchscreen concept sounded interesting, but the only way to determine how it worked out was to use it.

Before trying any serious applications, we booted up the demonstration disk because I wanted to play with the graphics game. To create a

drawing, you must first touch the screen in a least three places to mark the periphery. As I slid my finger around the screen, a small dot of light followed it. When I lifted my finger, the dot changed to a highlighted bar about the size of a typical cursor. This was obviously the first end point for the drawing. I selected several points this way, touched the label Draw Graphic in one of the eight function blocks (softkeys) at the bottom of the screen, and was fascinated as the

drawing started from each point and filled in toward the center (photo 8).

I hadn't touched the keyboard once, and I had learned everything I needed to know about using the HP 150 touchscreen: to select a point on the screen, I lift my finger, and to start an operation, I touch one of the highlighted blocks in the row at the bottom of the screen.

Then I moved on to more serious work.

The HP 150 will be packaged with

system continues to highlight every object as your fingertip passes or touches it. When the desired object is displayed in inverse video, you simply withdraw your fingertip and the system acts on your selection. This visual feedback compensates for the limited precision of the array of touch areas. Whether the HP touchscreen will meet your needs depends on the precision you require. If you need to select individual pixels, HPTouch won't do. But the touchscreen takes care of much of the interaction during applications programs, making many system-level operations effortless and natural. Touch is the easiest input device to learn and the hardest to give up.

But can you use the touchscreen as an input device in your BASIC programs? Yes. Miles Kehoe of HP provided a quick example of a touch-sensitive menu. (See photo 7 and listing 1.)

If you wonder what it's like to use the touchscreen in more sophisticated programming, read the programming sidebar, "Adapting Existing Programs to Use HPTouch: Picture Perfect, Diagram, and Wordstar" on page 48. It describes Micropro's experiences in adapting Wordstar (written in assembly language) to use the touchscreen and Computer Support Corporation's experiences in adapting the graphics programs Picture Perfect (written in BASIC) and Diagram (written in Pascal).

—Phil Lemmons

MS-DOS, Microsoft BASIC, and a program called Personal Application Manager. I wanted to follow the process a new buyer would—booting the operating system, formatting some disks, and copying the master. From there I would look at some of the application-software packages that will be available for the machine, including some old friends that have been modified for the touchscreen and some new programs developed for the HP 150.

Listing 1: This simple BASIC program will create the menu shown in photo 7.

```

1000 '
1010 'Sample Menu Selection Sub-Program us
1020 'Provided by TLA. All Rights Reserved
1030 'use of these routines is permissible
1040 '
1050 WIDTH 255 'Set 'infinite' screen width
1060 CLS$=CHR$(27)+"h"+CHR$(27)+"J" 'Home up, clear display
1070 '
1080 'FNLOCATE is similar to the LOCATE command in some BASICs
1090 '
1100 DEF FNLOCATE$(ROW,COL)=CHR$(27)+"a"+
STR$(ROW)+"r"+STR$(COL)+"C"
1110 '
1120 'FNTOUCH will define a touch field on the screen. The field
1130 ' will be three rows long and eight columns wide
1140 ' starting at the specified row and column. The
1150 ' character string to be returned is specified in
1160 ' the last parameter, and may be from 0 to 80 bytes
1170 ' in length.
1180 '
1190 ' The function as defined uses just one of many modes
1200 ' of touch field definition. The general form of the
1210 ' escape sequence is:
1220 '
1230 ' ESC - z g <row1>,<row2> r <col1>,<col2> c
1240 '
1250 ' <0/1> b <onenh> e <offenh> f
1260 '
1270 ' <rptmode> m <attr> a <len> L <response>
1280 '
1290 ' where:
1300 '
1310 ' The 'b' field determines whether a touch will beep;
1320 '
1330 ' The 'e' field specifies the video enhancement of the
1340 ' field when NOT being touched
1350 '
1360 ' The 'f' field specifies the video enhancement of the
1370 ' field when it IS being touched
1380 '
1390 ' The 'm' field specifies the type of field (ie, row/col
1400 ' reporting, ASCII (as shown here), etc.)
1410 '
1420 ' The 'a' field specifies when to report (on touch, on
1430 ' release, or both). ASCII mode is considered a 'keyboard
1440 ' replacement', hence reports on touch only regardless of
1450 ' this field (just like a keyboard key)
1460 '
1470 ' The 'L' specifies the length of the desired response string
1480 '
1490 ' <response> indicates the string to return when touched and
1500 ' may include a carriage return if desired
1510 '
1520 DEF FNTOUCH$(ROW,COL,CHARS$)=CHR$(27)+"-zg"+
STR$(ROW)+"","+STR$(ROW+2)+"r"+
STR$(COL)+"","+STR$(COL+8)+"c"+
"lb10e2f2mla"+STR$(LEN(CHARS$))+"+L"+CHARS$
1530 '
1540 REPT.MODE.ON$=CHR$(27)+"-z2n1A" 'Enable touch reporting
1550 REPT.MODE.OFF$=CHR$(27)+"-z0N" 'Disable touch reporting
1560 TOUCH.DELETE$=CHR$(27)+"-zD" 'Delete ALL touch fields
1570 '
1580 ' Display Main Menu
1590 '
1600 PRINT CLS$; 'Clear screen
1610 PRINT FNLOCATE$(0,20);"Sample TouchScreen Menu"
1620 PRINT FNTOUCH$(5,5,"1"); 'Define touch field in
row 5-7, column 5-13 to
1630 ' return ASCII '1'
1640 '
1650 '
1660 PRINT FNLOCATE$(6,6);"Option 1"; 'Put label in field 1
1670 '
1680 '
1690 PRINT FNTOUCH$(10,5,"2"); 'Define touch field in
row 10-12, column 5-13 to
1700 ' return ASCII '2'
1710 '
1720 '
1730 PRINT FNLOCATE$(11,6);"Option 2"; 'Put label in field 2
1740 '
1750 'Now enable reporting and wait for a character
1760 PRINT REPT.MODE.ON$; 'Turn on reporting mode
1770 'Input single character from keyboard OR touchscreen
1780 A$=INPUT$(1)
1790 PRINT REPT.MODE.OFF$; 'Turn off reporting
1800 IF INSTR("12",A$)=0 THEN PRINT CHR$(7);;
GOTO 1760
1810 IF A$="1" THEN CHAIN"PROG1" 'Did not type a 1 or 2
'Selection 1
1820 CHAIN"PROG2" 'Must be Selection 2
1830 END

```

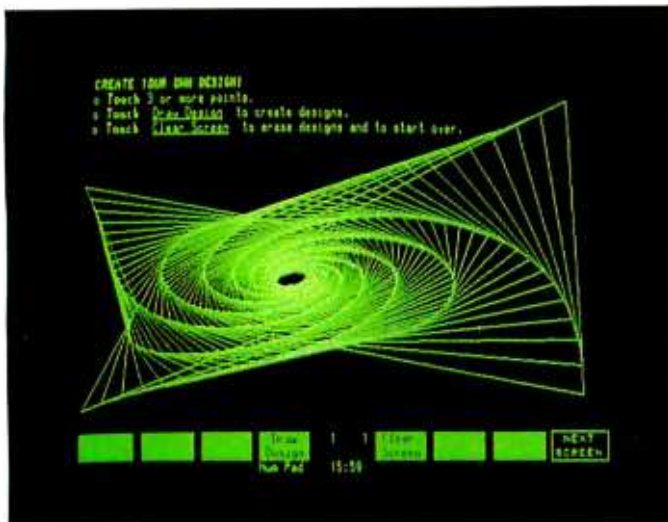



Photo 8: A graphics-demonstration program by Hewlett-Packard for the HP 150.



Photo 9: HP's operating system shell. Touch an application name to select it, then touch "Start Applic." to run it.

P.A.M.

When you boot the system, instead of the familiar `A>` from MS-DOS and a blank screen, you see Hewlett-Packard's Personal Application Manager, P.A.M., on the screen. P.A.M. automatically displays in alphabetical order the names of all the installed programs on the disk. Photo 9 shows the first screen with several installed applications displayed.

A small arrow pointed to the application named Format A, and it was highlighted, so I knew this was the default selection. I simply touched the Start Applic. softkey and the format screen appeared, with several bars indicating disk drives (photo 10). I touched the second bar for drive B, typed a label for the disk when prompted, then touched HP Format. A small asterisk appeared next to the label. When the formatting was completed, the Exit Format softkey returned the P.A.M. main menu.

Three touches to format a disk, and I didn't have to learn or remember any operating-system commands! The only time I used the keyboard was to type the optional disk-drive label.

Hewlett-Packard decided early in the project to use the standard MS-DOS operating system (although the company added some features—see the interview with Jim Sutton and John Lee on page 51) so that many popular software packages could run

on the HP 150. To facilitate learning and use of the system, they created P.A.M. as a shell for the operating system.

The first P.A.M. screen (photo 8) demonstrates the convenient and simple user interface. This interface is common to all the programs Hewlett-Packard is offering for the HP 150: at the top, a program and menu name followed by a line for application prompts and messages, and at the bottom, a row of softkeys followed by a line for system messages and the clock. (Hewlett-Packard wasn't sure if the clock would be in the final version. Personally, I hope it is. I often lose track of time when I'm working on a computer.)

The softkeys replace traditional function menus whose items are usually selected by typing in code letters or numbers. In addition, each softkey in a row can lead to an entire tree structure of more softkey functions accessed by touching the screen.

The software discourages accidental selections. You must move your finger directly into the softkey area. Sliding to a softkey doesn't work. However, because you don't actually have to touch the screen, a finger hovering in the softkey area sometimes produces unexpected results. Selections are always highlighted for visual feedback, and in addition, when a softkey is selected, it clicks.

The function keys at the top of the keyboard mirror the softkeys on the screen. You can carry out any operation named on a softkey using the corresponding function key.

Now to copy the master disk. After I touched the Copy/Backup softkey, screen messages prompted me to type the drive letters to copy from and to. When I entered A: (copy from) the names of all the directories and files on the disk in drive A appeared on the screen. I chose the Copy File softkey when prompted; I suspected I could select any files I wanted to copy by touching the file-names, and in fact, I could. As I moved my finger from one to another, highlighting each in turn, the small arrow followed. Only names from which I lifted my finger remained highlighted (photo 11). The Start Over or Unselect by Name softkeys undo selections.

I wanted to copy the entire master disk, so when I finished playing with the touchscreen, I touched the Select All and Start Copy softkeys. The number of bytes available on the disk in drive B (in the counter at the top right of the screen) decreased until they matched the bytes available for drive A. The computer politely beeped when it was finished.

Four touches (and two disk-drive letters typed) from the File Manager menu, and I had copied the master disk.

In addition to the Copy Files func-



Photo 10: You can format disks in several drives simultaneously.



Photo 11: Select files to copy by touching the filename on the screen.

tion, P.A.M. has a Backup function that stores files in a compressed format. With this function, you can select files by name or date. The program has enough intelligence to know when there is not enough space left on a disk for the next file and will fill the remaining space with smaller files, then prompt you to change disks. Users with hard disks will find the Backup function especially helpful for archiving data on floppy disks.

The P.A.M. shell works. It simplifies standard MS-DOS functions such as formatting and copying disks. Enhancements such as automatically displayed directories are convenient.

All the programs offered by HP are automatically installed to run under P.A.M., and programs added later are easy to install. You can customize P.A.M.—changing application names, rearranging names on the screen, setting any application to start automatically—all by touching softkeys. Users who prefer standard commands can select the MS-DOS Commands application on the main P.A.M. screen.

When you have disks in more than one drive (the HP 150 can handle 12 disk drives), P.A.M. will display, alphabetically, the names of all the installed programs on all the disks along with the letter code for the disk drive. Disks in several drives can be formatted simultaneously.

The P.A.M. instructions are easy to

understand, consistent, and predictable. I used the system without once consulting a manual. There's no need to learn how to use the pointing device to position the cursor: there is nothing abstract about touching a particular place on the screen with your finger. In contrast, most computer systems require users to learn, remember, and always type correctly cryptic codes such as "dir a:" and "copy a:filename.xxx b:filename.xxx" in a precise and initially mysterious format. Utility programs created specifically for a touchscreen are remarkably easy to use. I wanted to see how touch changed some old friends: Visicalc and Wordstar. They are among the applications that will be available when the HP 150 is introduced.

Visicalc

I touched my way back to P.A.M., selected Visicalc, touched Start Applic., and saw Visicalc on screen. Just as in P.A.M., the top line of the screen contains the program and menu names, the second line a message, and at the bottom is the familiar row of softkeys.

Rather than create a new worksheet, I chose one from the directory displayed in the File Manager. It's easy to move back and forth from any application to the File Manager. Touching the File Manager softkey puts the application on hold; the Back to Visicalc key sends you back

where you were (see photos 12 and 13).

Of course, I immediately wanted to know if I could select a cell by touching it. I could, although it's a little tricky. It's easy to highlight the column you want, but positioning the highlighting on a particular row takes some practice. Still, it's often a lot easier than typing.

The softkeys contain most of the Visicalc commands, and I was able to use touch alone to move cells, replicate, open multiple windows, and select format and printing functions. Data can be transferred to a graphics program by touching a softkey (see photos 14 and 15).

Experienced Visicalc users may find the familiar slash commands faster than touching softkeys. But they will be pleased with enhancements like additional print functions (photo 16), cell formats and protection, and multiple windows.

Wordstar

My fingers did the walking back to the familiar Wordstar opening menu, touched a softkey to open a file, and typed a new file name. A screen, blank except for the softkeys, quickly appeared (photo 17). Having the Wordstar help menus on the screen would be redundant, so the help level is set to zero, allowing most of the screen to be used for text.

I couldn't wait to try my nemesis, a block move. I succeeded in mark-

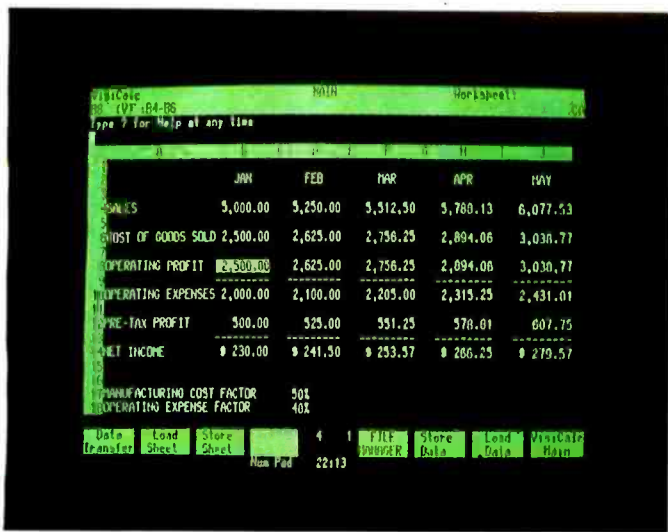

Photo 14: To select a cell, touch it.

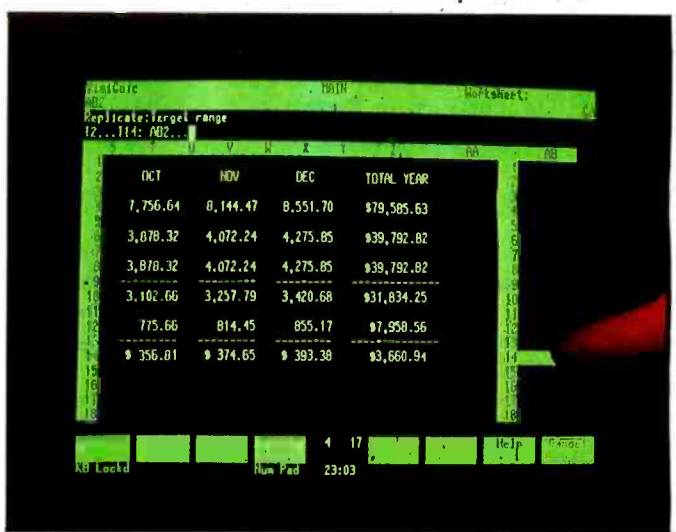

Photo 15: HP's enhanced VisiCalc allows multiple windows.

who want a quick and easy way to enter text.

Even with the advantages the HP 150 gives to Wordstar, many people don't need or want to learn how to use a full-featured word processor. That's why HP offers Memomaker. With touch to position the cursor and select softkeys, and dedicated keyboard keys for functions such as inserting a line and deleting a character, you don't need to learn or remember any commands. Most people could use Memomaker fully—to write letters, create memos, and do rough drafts—without ever reading the documentation.

As in Wordstar, I used the touch feature to position the cursor and do block moves. I also tried changing the

right margin and realigning the text. Touch makes these functions as simple as they should be. (See photos 20 and 21.)

I could go to File Manager, select files, and read them into Memomaker without ever using the keyboard or learning any commands (photo 22).

Memomaker shows text enhancements on screen—highlighting emphasizes boldface, and italic characters indicate underlining. Margins, tab settings, and standard memo formats can be stored in format files and read into a document.

Because Memomaker and Wordstar are fully compatible, documents created in one can be edited in the other. An experienced Wordstar user

can add advanced features to Memomaker documents, while someone unfamiliar with Wordstar can use Memomaker to edit a Wordstar document. Memomaker is a great little word processor for people who don't want to do serious word processing.

Personal Card File

The demonstration program for the HP 150 includes a sample of a name and address program called Personal Card File (PCF). The screen for this program has a drawing that looks like a typical rotary card index found on many desks. To access a card in the file, you touch a tab as if the card file were made of paper and plastic; to rotate the card file, touch the handles—again, as you would with a

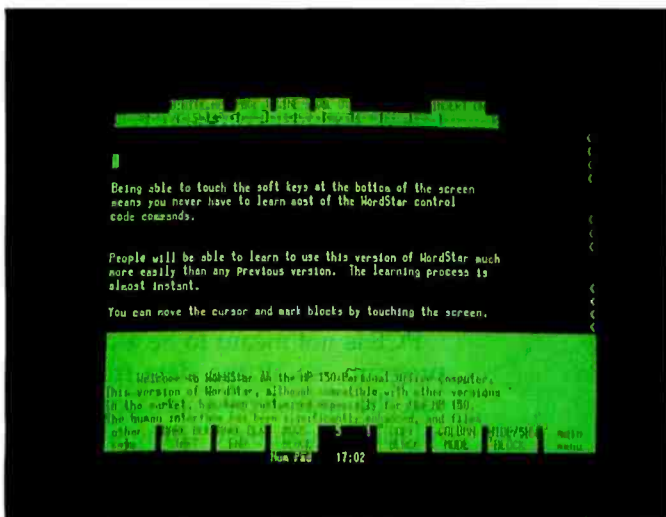

Photo 18: The cursor shows where I touched the screen.

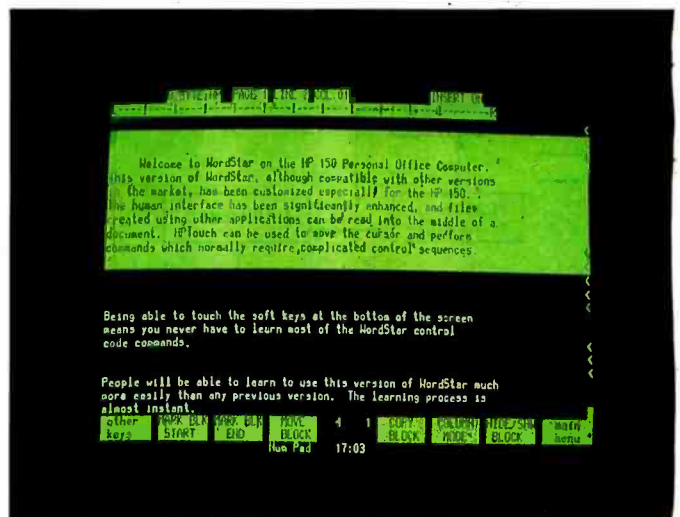

Photo 19: The result of a block move accomplished entirely by touch.

Adapting Existing Programs to Use HPTouch: Picture Perfect, Diagraph, and Wordstar

Two software houses experienced different levels of difficulty in adapting existing software for the HPTouch system of the HP 150 Personal Computer. Computer Support Corporation found it easy to adapt its graphics software, but Micropro had some problems because of the unusual internal structure of Wordstar.

Picture Perfect and Diagraph

Picture Perfect is a general charting program that makes it easy to do business graphics, such as bar charts with three-dimensional effects. Diagraph is a program that lets you draw flow charts, organization charts, circuit diagrams, and the like by using a library of approximately 100 primitives, including a variety of polygons and many common symbols. Computer Support Corporation of Dallas, Texas, is adapting two programs to run on the HP 150 and to use HPTouch. One program is written in Pascal and is being rewritten in the Pascal of the HP 150. The other program is written in BASIC and is being converted to the Pascal of the 150.

Michael Kallet and Jack Hudler of Computer Support explained how to use HPTouch this way: "You access the touchscreen through the HP 150's AIOS (alpha-

numeric input/output system), which is in ROM. You need to write some low-level assembly-language routines to access the AIOS. The same linker on the 150 handles both assembly language and Pascal.

"In fact, you access the touchscreen just as if it were any other input/output device. You call an assembly-language routine to set up the mode of the touchscreen that you want to use. We thought we would always be defining touch areas in terms of coordinates, checking for touches within the coordinates, and then going to commands that were mapped to the touch areas. But the touchscreen has a mode that makes the touch areas actually return a particular value just as if they were keys on the keyboard. Another mode lets the user define an object by touching the screen.

"The most useful mode is the one that makes the touch areas return keycodes. You turn that mode on and then set the touchscreen to report when it's been touched. Then you read the keyboard and wait for the return of a keycode and a qualifier. The qualifier says whether the code came from the keyboard or the touchscreen.

"Because of its different modes, the touchscreen is more powerful than you realize at first. You could use the row-column mode all the time if you wished, but you end up using the mode that directly returns a particular value.

"In interpretive BASIC, you can turn screen areas on and off with escape sequences. In Pascal, you make assembly-language calls to AIOS routines. Interfacing

to HPTouch is easy in either case."

Adapting Wordstar

Since Wordstar is written in assembly language, Micropro is using assembly-language calls to the AIOS to adapt the popular word processor for HPTouch. Programmer Joe Masters reports, "For every character typed or screen area touched, you get information about which device the returned value came from, whether shift or control was pressed, and so on. This information comes to you from the console I/O portion of the operating system. The AIOS interprets the information.

"There are routines in the AIOS for writing a line to the screen, writing an entire screen, getting coordinates from the screen, and so on. The existing Wordstar makes multiple single-character output calls to write a line. With the HP 150, you can write an entire line at a time by calling a routine in the AIOS. It's difficult to get used to, but once you do, development goes much faster."

Kirk Hurford, manager of Micropro's OEM support group, explained the method of adaptation: "In adapting Wordstar for specific hardware, we go directly toward the I/O. Wordstar operating in the MS-DOS environment has much slower I/O because of the path that it takes through the operating system. In the case of the HP 150, the effect that we put forth to improve performance is sophisticated. There is a fair amount of intelligence with which Wordstar makes decisions as it's up-

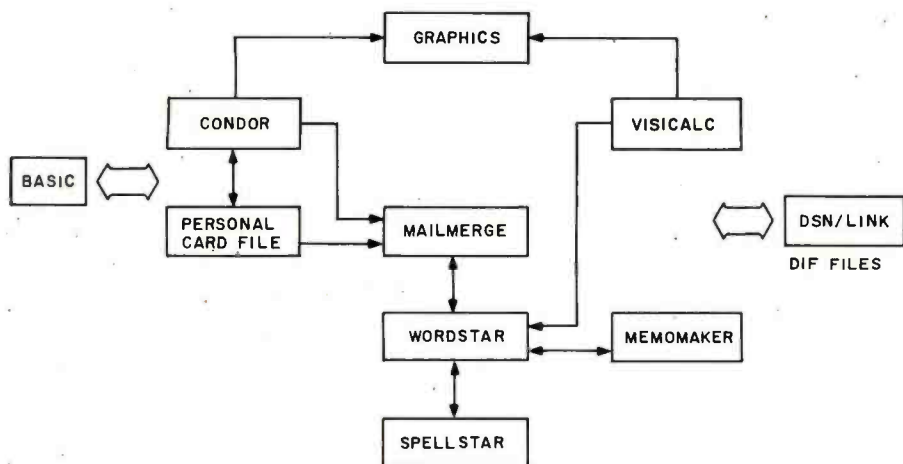

Figure 1: This map shows the data transfer possible among the HP 150 applications.

desktop cardfile. (The "At a Glance" box on page 41 shows the card file in action.)

PCF is designed to keep a handy list of names and addresses (which can be used in Wordstar form letters via Mailmerge). Key-field data appears on the tabs, and the file is sorted in key-field order. To search and select data for an abbreviated version of the card file, select fields and type the criteria.

PCF is not meant to be a database program, so all the data from PCF can be transferred to Condor, a relational-database program, for more sophisticated manipulation.

Graphics

With the high-resolution screen and a good selection of plotters

dating the screen. Wordstar uses different AIOS calls based upon what it knows it's going to do. When it's updating characters, for example, it uses different functions from those it would use when it knows it's going to write an entire line.

"Without the AIOS, we would not have achieved the high level of I/O performance that we have on the 150. The only other version of Wordstar that is as fast is the latest version for the IBM PC. That took three programmer months. Achieving the same speed on the HP 150 took five programmers weeks."

Masters made it clear that the hard part of adapting Wordstar for the 150 was on the Wordstar side, not the HP side. "The part of the adapting that has to do with the touch interface itself is self-explanatory. The documentation and a test program have examples of using the AIOS. But what we're doing on the Wordstar side is difficult."

Hurford explained why: "Wordstar is 14,000 lines of assembly-language code. The customization of the HP 150 is complex even though we get the information that we need from the AIOS instantly. It tells us where to go on the screen. The hard part is telling Wordstar how to get there."

"Wordstar identifies a screen location," Masters said, "not by referring to coordinates on the screen but as a 24-bit position in the file. There are lots of translations that have to take place to make Wordstar understand what the AIOS has told it."

available from Hewlett-Packard, it's not surprising that HP will be offering three graphics programs for the 150—its own Series 100 Graphics plus two from Computer Support Corporation (Picture Perfect and Diagram).

The Series 100 Graphics can use data from Visicalc or Condor to plot bar charts, line graphs, pie charts, and scattergrams on paper or slides. You can transfer data in, select pen colors and shading, choose options such as horizontal or vertical orientation, and pick paper type all by using touch. Photo 23 shows the Series 100 Graphics screen.

Photo 24 shows a bar chart created with Picture Perfect. Because of the HP 150's high resolution, the bar chart assumes an almost three-

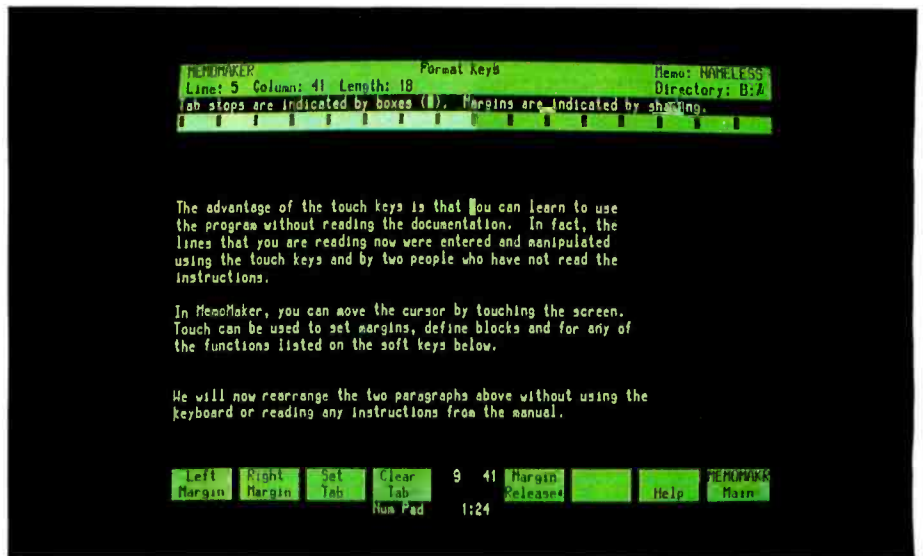

Photo 20: All the commands for Memomaker are on softkeys. The cursor is positioned for a new right-margin setting.

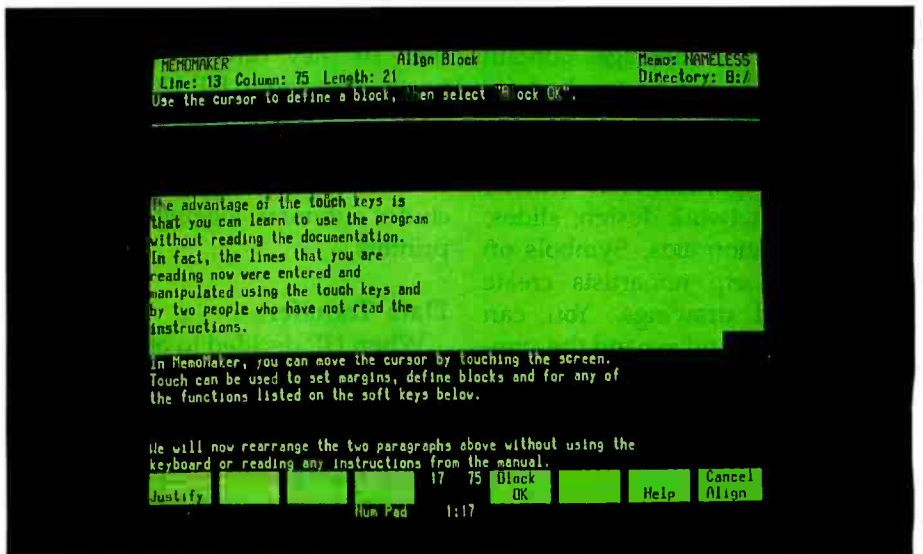

Photo 21: Realigning a block of text for the new right margin can be accomplished entirely with touch.



Photo 22: You can store memo formats in a separate file and read them into Memomaker. The asterisk in the Help softkey shows Help is toggled on.

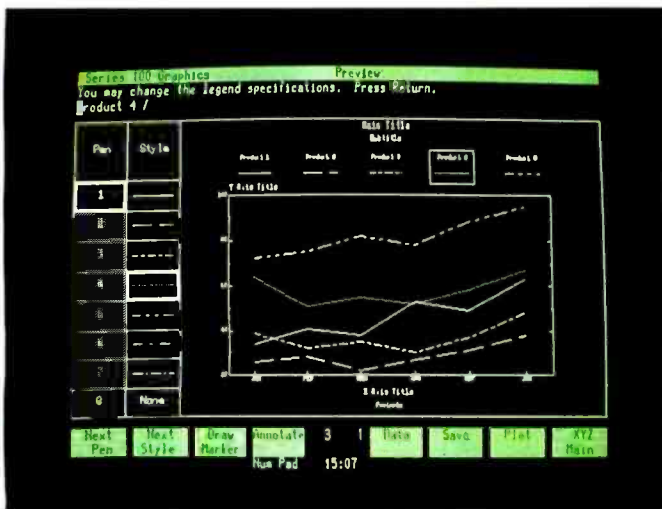

Photo 23: Series 100 graphics from HP use touch to select pen color, style, and the functions you see on softkeys.



Photo 24: A Picture Perfect bar chart demonstrates the high character resolution on the HP 150.

dimensional appearance. Softkey menus can be used to define and adjust charts. Help messages contain key words that can be touched for additional help.

Diagraph can be used for flow diagrams, organizational charts, schematics, network design, slides, and presentation aids. Symbols on the screen help nonartists create sophisticated drawings. You can move, connect, and expand the symbols by touching the screen.

Communications and File Transfers

To use the HP 150 as a terminal for communications, simply boot up P.A.M., touch the Terminal softkey to access the four configuration menus, then, using touch or the keyboard, enter or change information to set a configuration.

Instead of typing configuration data, you can use touch to select data on the screen. For example, the "baud rate" prompt displays a new bit-per-second rate with each touch.

For file transfers, Hewlett-Packard offers the DSN (Distributed Systems Network)/Link program. DSN/Link can transmit both ASCII and binary data.

Transfers to the HP 3000 are easy and include error checking. Name the file you want to send or receive and initiate the transfer by touching the screen. Transfers to other computers require customization, but log-on procedures and repetitive com-

mands can be stored in a file, and a softkey may be assigned for those files so they can be accessed by touch. Transfers to HP 120s, 125s, and 150s can be made without a host-computer connection. Transfers can be unattended, and the program includes automatic logging to disk and printers.

Data Transfer

When HP decided to offer popular software packages on the HP 150, the company worked on facilitating data transfer between them. Figure 1 illustrates the possible data transfers among Wordstar, Condor, Visicalc, Memomaker, PCF, and graphics. (Jim Sutton and John Lee explain how they accomplished data transfer on page 51.) The data transfer isn't as extensive as it would be in a fully integrated program designed for this purpose, but there is probably enough movement possible for most applications, and most transfers can take place using softkeys alone.

What Makes It Magic?

It's not just the touchscreen that makes this machine magical. It's the combination of ease of use, sophistication, and low price.

The decision to use a standard MS-DOS operating system means software houses can quickly modify their popular software packages for the HP 150. Users familiar with these programs can easily switch to touch. Novice users will find difficult pro-

grams are easier to learn with the touch interface.

The modification of applications to use a common user interface gives a cohesiveness and predictability to all the programs on the HP 150. P.A.M., HP's solution to the MS-DOS A > interface, gives new users a place to start and makes utility commands convenient for everyone.

But users who wish to can ignore the touchscreen in P.A.M., or any other features that don't appeal to them. Few, however, will ignore touch. Pointing to a spot on the screen is natural, and HP has paid careful attention to preventing accidental selection by touch. Mistakes are less likely than with a traditional system that uses keyboard keys to issue commands. Anyone can quickly begin using this system and its applications.

The HPTouch interface isn't flashy. It lacks spectacular effects such as desktops full of icons and overlapping windows. These omissions don't cause any sense of deprivation; in fact, they help achieve a simplicity that contributes to the system's elegance.

Although elegance can suggest formality that often signals "don't touch," the HP 150 invites us to touch. That makes the HP 150 as inviting as it is elegant. Certainly the HP 150 represents real progress toward the goal of putting high technology at the disposal of ordinary people.

—Barbara Robinson ■

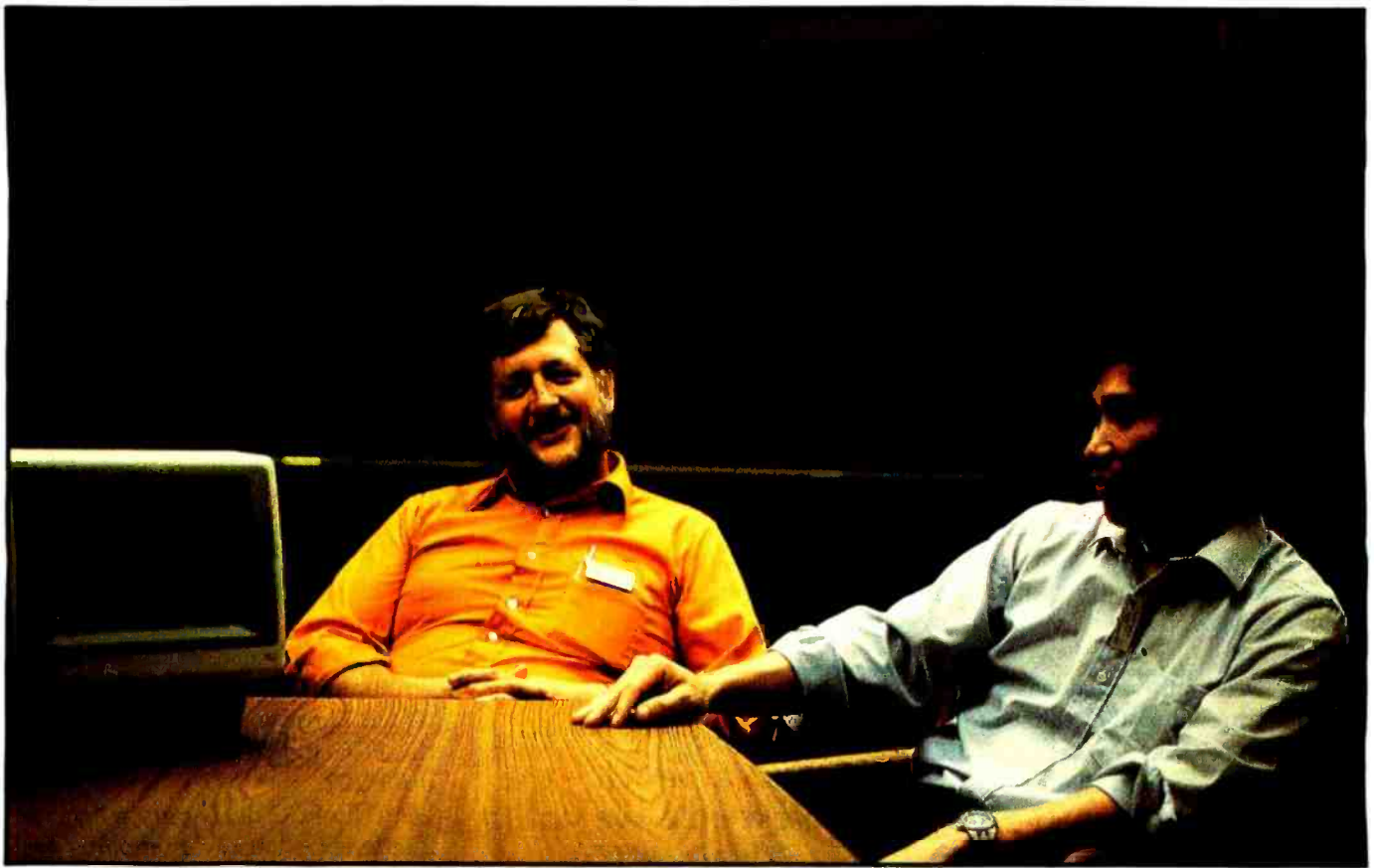

An Interview: The HP 150's Design-team Leaders

by Phil Lemmons and Barbara Robertson

Jim Sutton and John Lee led the design team for the "Magic" personal computer system, now known as the HP 150. Sutton is a research and development section manager in the personal software division. Lee is a research and development project manager in the personal office computer division. Both talked to BYTE West Coast editors Phil Lemmons and Barbara Robertson at Hewlett-Packard's offices in Sunnyvale, CA.

BYTE: What are the most innovative things about the HP 150's hardware?

Lee: The touchscreen and the compactness. The touchscreen is not a new input device, but getting it into the box and lowering manufacturing costs took a major effort.

BYTE: How did you go about doing that?

Lee: We researched the touchscreen and did some preliminary models, trying to get it to work with very inexpensive standard LEDs and photodiodes.

BYTE: You used the optical approach because of inexpensive parts?

Lee: Well, the optical approach means we don't have to put a special film on the CRT that reduces the contrast and visibility. Also, with the optical approach, you usually don't have the radiation problems that you get with other types of signals going across the screen. We also made sure our design provides ways of loading the parts so that each individual cell doesn't have to be adjusted separately. That reduces our production cost.

Sutton: One of the other issues in selecting that particular mechanism for having a touchscreen was to make sure it would be at least as reliable as

the other components in the system. Some of the technologies that we looked at early on didn't seem to promise that kind of reliability. With this particular technology, the touchscreen would not be the first point of failure in the system.

BYTE: How did you decide what resolution the touchscreen should have?

Lee: As far as resolution is concerned, it's really the pointing device's resolution that matters more than the screen's resolution. The sharper the pointing device, obviously, the more precisely you can point. A light pen can get close to a pixel

resolution, but we considered having to pick up a special device with a wire attached to it less friendly. So our resolution requirement was the end of a pencil. That was the smallest size we could deal with. Normally you deal with finger size, which is larger than pen size.

BYTE: Did you decide to use touch and begin thinking of how it might be used, or did you originally look for another input device?

Lee: We were really looking for a friendlier way of interacting with the computer. We had already used labeled softkeys on the screen that match a top row of function keys. The softkey labels could change when the keys changed their functions, but their use was limited by the keyboard.

Sutton: Originally, touch was an optional feature. Over the course of the development of the product, we convinced ourselves first of the value of touchscreen and second of our ability to manufacture it for a cost low enough to make the touchscreen a standard feature of the product.

We also had some customers directing us toward the touchscreen as an input device. HP has a partner's program in which we work with certain major customers in a very active role and reveal to them some of our future products with an agreement that they won't reveal them. In return, they give us some valuable insights into the products. Some of these customers played significant roles in deciding on the touchscreen's role in this product.

BYTE: Did anyone argue for eliminating cursor control or programmable function keys, forcing people to go through the touchscreen interface?

Lee: I think it was originally designed so that you were able to do anything from the keyboard because at that time the touchscreen was optional.

Sutton: Nothing restricts you from using the keyboard as the only mode of cursor positioning. Customers who choose to do coding might use the keyboard rather than the touchscreen mode. But in some applications—for example, on a shop floor—there might be no more than a cou-

ple of dozen possible input choices. Then it would be perfectly reasonable to put up the 24 possible choices so that someone wearing a heavy leather glove could poke at the touchscreen and use it as the total input system.

BYTE: What was the process by which you designed the keyboard?

Sutton: A group was formed to try and unify HP's planning for keyboards, and it did a thorough study on the ergonomics of the keyboard.

BYTE: How did you do that study?

Sutton: I understand it was done by reviewing all of the external studies that have been done as well as reviewing the ergonomic standards established and particularly the European standards.

Our resolution requirement was the end of a pencil—the smallest size we could deal with.

BYTE: According to the International Standards Organization?

Sutton: Right. We also did a lot of testing with a number of mock-ups that we built. The tilt and swivel features of the main unit are because of the same international ergonomic considerations.

BYTE: Does moving to a different part of the world affect the touchscreen?

Lee: There are differences as you move into the Southern Hemisphere, where the magnetic fields are different and affect the convergence on the CRT. After we have converged it and centered it for the Northern Hemisphere, there is a shift when we take it to South America. The user can realign the touchscreen by using one softkey that brings up an alignment grid on the screen.

BYTE: What are you aligning at that point?

Lee: There is a set of holes you can see on the side of the plastic bezel. That's where the light beams come through. We put a grid on the screen in graphics, and you position the whole graphic screen to align with

the holes. In fact, that would probably be necessary in the Northern Hemisphere if you dropped the machine and the yoke at the back moved a little.

Sutton: Our production engineers in manufacturing have been quite concerned with making sure we had an adequate solution to this problem. The need for adjusting the screen has been minimized, but if it becomes necessary it's easy.

BYTE: What was the most difficult part of the hardware design?

Lee: The compactness, fitting everything into the box. That—and also meeting all the regulatory standards set up by FCC and DBE.

BYTE: DBE is the German equivalent of our FCC?

Lee: Yes. HP also has its own environmental standards to meet.

BYTE: Those are more stringent than the FCC standards, or unrelated to the FCC?

Lee: The FCC deals only with radio interference. We have standards dealing with shock test, transportation, and electrostatic discharge (so that if you are charged and touch the box, you will not cause the system to reset). Actually, the most important thing for any computer user is data integrity. We try to make sure that nothing that the user can do will cause loss or corruption of data. Every bit counts.

Sutton: You were asking about the keyboard earlier. In fact, although we get our key switches from a very good vendor, and the vendor does extensive testing, we subjected all key switches to millions of keystrokes with mechanical hands, off-center keystrokes with millions of repetitions, and so on. This testing identified some problems so we went back to the vendor and collaborated until we got solutions to those problems. That's fairly typical. Usually we have standards internal to HP that are higher than any of the standards that come from regulatory agencies.

BYTE: What did you have to do to get everything into that little box?

Lee: Well, there are some design trade-offs. For example, not using an 8086, which would require a 16-bit bus instead of the 8088's 8-bit bus. In

general, when you do logic design you have to pick parts very carefully to make sure you don't use too many SSI (small-scale integration) parts.

Also, you make sure that the chips will be in sync. The 8088 needs a lot of support chips, and the major functional chips must talk well to one another so you can massage the signals going from one to the other.

BYTE: What sort of a CRT is necessary to get the resolution so high on a 9-inch screen?

Lee: The CRT itself is not the major problem—it's the electronics that drive it, the discrete analog circuitry. We run at about twice the frequency that people normally run, so our analog circuitry has higher frequency response requirements. That usually creates the much higher resolution you see on the screen.

BYTE: The graphics are very fast. What did you do to make them that way?

Lee: There are both hardware and software factors. First, we have one gate array that handles our graphics display. Second, there is a careful design of the algorithms that do the graphics. We have a very strong graphics group that understands the algorithms of doing vector drawing, area fill, and so on.

BYTE: The gate array plays the role of a video-controller chip?

Lee: That's right, for the graphics.

BYTE: What about character-oriented I/O?

Lee: There's a separate controller. We have two planes, a graphics plane and an alphanumeric plane. A Standard Microsystems 9007 does the alpha control. It's a highly functional chip that replaces a lot of peripheral chips needed with the other controllers we have been using. The 9007 also does a lot of things itself without requiring the processor to support it. Even if the processor stops, the screen will not. The screen will be refreshed properly.

BYTE: Is some RAM (random-access read/write memory) dedicated to graphics storage, or is it all one continuous address space?

Lee: It's one continuous address space, but there are separate RAMs for the display because they need

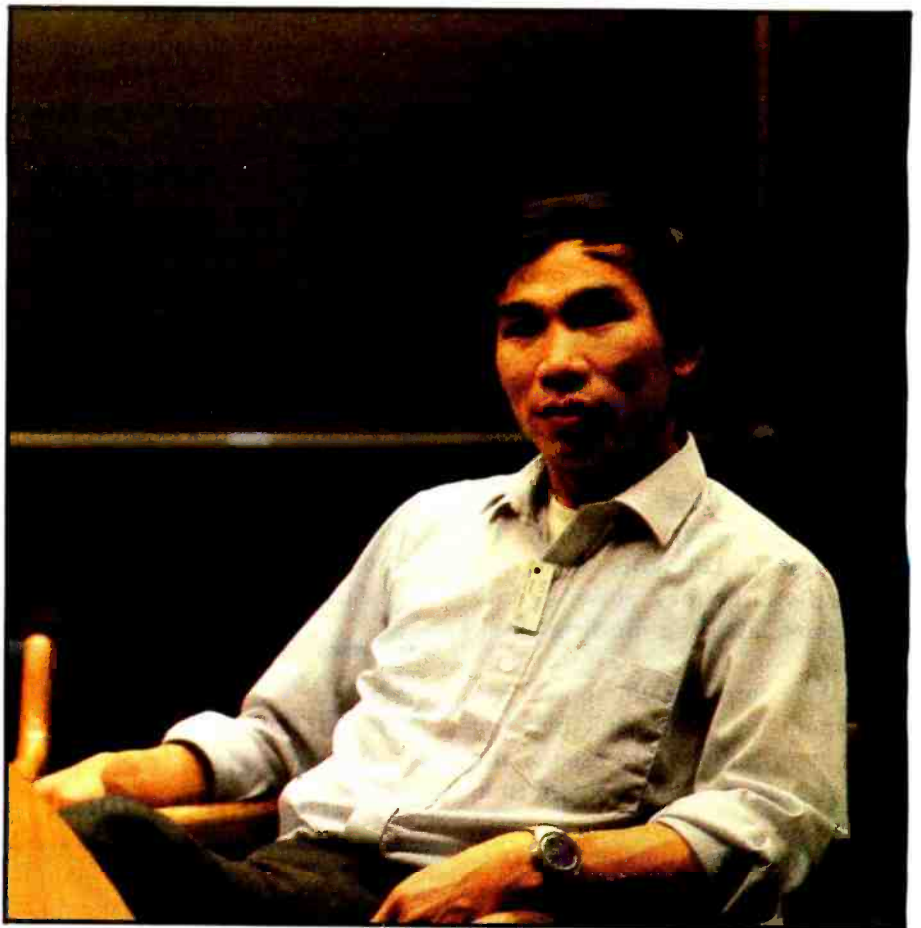

John Lee, project manager for research and development in HP's personal office computer division.

much faster access. We use some static RAMs.

Sutton: One of the other things that makes graphics fast from an applications point of view is the additional level of interface to graphics that is accessible without going through some of the overhead associated with the operating system.

BYTE: The GIOS?

Sutton: That's right. The graphic I/O system allows an application using this level of interface to do so without incurring some of the overhead that would otherwise be necessary.

Lee: That software interface also has some other very important purposes. Most computers actually go directly to the hardware in order to enhance their performance. That poses a very serious compatibility problem in the future, because hardware will change. The GIOS and AIOS (alphanumeric input/output system) interfaces give you high performance but are software, so future products can be made compatible.

BYTE: Looking at other controllers, what microprocessor is in the keyboard?

Lee: I guess it would depend on what you call the keyboard. The keyboard itself has no microprocessor in it, just a few random logic chips. We use an 8041 on the main processor board to handle the touchscreen and the keyboard.

BYTE: Tell us a little bit about the HPIB (Hewlett-Packard interface bus) and how that affects adding peripherals to the system.

Lee: The HPIB has been accepted as an IEEE standard and we conform to it. That bus provides the flexibility to add a lot of peripherals through one connector in the main unit. You can just tie in the whole daisy chain without any restrictions, except for the electrical and loading restrictions. You can add disk drives and plotters and printers through the same bus.

BYTE: What CPU chips did you consider, and why did you choose the 8088?

Lee: The personal computer market tends to be mainly concentrated on the Intel processor family. The Intel family was chosen so we could run an industry-standard operating system. Other HP divisions are developing systems based on other processors, focusing on the Intel family.

BYTE: Will the hardware be an open system? Will you cooperate with companies that want to make add-on products?

Lee: Definitely.

BYTE: Does that apply to software as well?

Sutton: Yes, it does.

BYTE: The power supply in the main unit is 120 watts. Isn't that unusually large for a power supply that isn't also supporting disk drives?

Lee: We computed the power requirement for up to 640K bytes of RAM, with all the processors, the video, plus an internal thermal printer. . .

BYTE: The power for the printer is in there, too?

Lee: Yes. The power supply will support the printer and we have some left over for the option cards. In fact, some of the option cards could take quite a bit of power.

BYTE: Can you print the screen image at any time with this system?

Sutton: Yes, that's true, but with one caveat. It's really printing the internal memory image, not the screen, as you might expect. There are separate planes for graphics and alphanumeric, and, generally, you can print the normal alpha you see on the screen and the graphics you see on screen, but if you are seeing alpha on top of graphics with both planes displayed at once, you cannot get those printed out and overlaid correctly.

BYTE: What manages the HPIB and the serial ports?

Lee: The HPIB is managed by an HPIB controller chip from Texas Instruments, and the serial ports are managed by the NEC 7201 serial protocol controller.

BYTE: Did you make changes in hardware because of things that came up in the software? Jim, was there anything you asked John to do so that you could do something you

were having trouble with?

Sutton: Clearly we made changes in the firmware because of things that came up in the applications. John's role has been primarily the firmware. He's been very helpful to us in terms of being able to provide the right kinds of AIOS and GIOS calls for us to be able to get the very high screen performance that we want.

BYTE: John, you actually did the AIOS and the GIOS?

Lee: A lot of people got involved in that because it involves everything from the operating system to. . .

Sutton: However, the answer's yes.

BYTE: What about manufacturing methods? Is HP active in automated manufacturing?

Changes were made in the firmware because of things that came up in the applications.

Sutton: We are increasingly interested, as are all companies, in this area, to both improve our quality and reduce our manufacturing costs through factory automation. If you walked out through the back room you would see some strange-looking robots making their way among the various devices.

We also have manufacturing representatives involved at extremely early stages in the design of any product like this, to make sure that the product is easily manufacturable with the kind of quality that we like to have associated with HP.

Lee: Manufacturability is an issue that's addressed on day one. It affects some of the things that we do—how the boards are laid out, where the holes are and how many screws we need, and other such considerations. Currently I would guess our most automated process is building the PC board. Production is automated and so is testing.

BYTE: You already have disk drives in different sizes that use the HPIB, so all the 3½-inch, 5¼-inch, and 8-inch drives are available for the 150 at its announcement?

Lee: Right, all those drives, the Winchester and floppies.

BYTE: How compatible is the 150 with IBM PC software?

Sutton: Software that was written originally for the IBM PC is transportable directly into our environment so long as it doesn't depend on special hardware features of an IBM device and uses vanilla MS-DOS calls. If it does use vanilla calls, then it will work equally well with our vanilla MS-DOS. Of course, our graphics resolution is somewhat different, so things that are written to make specific use of our graphics may not be directly transported to the IBM PC. Conversely, things written to make use of special features on the IBM PC may not be directly transportable to the HP 150. People willing to make the effort of using special features in the IBM PC environment may well like to use the special features in our environment. For example, to be able to get the kind of screen performance that we have.

BYTE: Will you be offering a Winchester drive unit with the same form factor as the double micro-floppy unit?

Sutton: Yes. Those units will be available at first shipment of the 150.

BYTE: Did you consider developing your own operating system with perhaps an iconic interface and bit-map graphics, with your own applications integrated into that?

Sutton: Yes. We did a significant investigation and a reasonable amount of work on our own interface and an operating system that provided some substantial additional features over MS-DOS. But we viewed access to software already in the marketplace as critical to the success of the product. We decided to use MS-DOS for that reason. We would like to provide an extremely wide variety of industry-standard software at the same time we provide another rich set of our own software, which will be more valuable than competitive products in the marketplace.

Lee: Users should not really have to be aware of what operating system the software is running under. What they're more concerned with is how they're interacting with the system,

and that's really through a shell or a program that's running on top of what traditionally is called an operating system. I think we achieve the added user-interface capability without having to change the standard functions that MS-DOS provides.

BYTE: How would you describe the operating-system architecture? Where does the touchscreen fit into that?

Lee: The touchscreen is just another device in the system.

BYTE: Handled the same way the keyboard is?

Lee: Handled similarly to the keyboard.

BYTE: Where do the AIOS and GIOS fit in?

Lee: You can view them as an extension of MS-DOS functions. What we want to do is design compatibility for future products at the operating-system level. MS-DOS is a standard operating system and changing it would make it nonstandard. But we still want to define a variety of new functions that a standard system cannot provide. So all the new functions fit within the MS-DOS definition. What we do is go through the I/O control path of MS-DOS system calls to access all the AIOS and GIOS functions.

BYTE: What is the AIOS?

Lee: In a nutshell, what AIOS does is replace what current systems do to write directly to video. That's the main goal of AIOS as far as output is concerned. We want high performance and multifunction capability to write to video and much tighter control of what people see on the screen. We provide that functionality while at the same time hiding all the hardware dependencies of the system. We defined a logical interface that can be transferred.

Sutton: You can think of AIOS and GIOS as being at a lower level than MS-DOS. They bypass some of the things that would normally go on in terms of typical device output in MS-DOS. At the same time, the AIOS and GIOS are in essence at a higher level because instead of being character-oriented in terms of its output, for example, they can deal with large blocks of text going to the screen at



Jim Sutton, section manager for research and development in Hewlett-Packard's personal software division.

once. As a consequence, you can bypass many of the inefficiencies of the usual way of getting to the screen, and at the same time do things in large blocks of data rather than a character at a time. The net result is multiplicative, making the actual screen transfer rates very high.

Lee: The input our system allows is very important. In a standard system input is single-character-oriented; hit one key, and you get one character. That is very limited information. For example, the up-arrow key is a non-ASCII (American National Standard Code for Information Interchange) key, so you have no standard ASCII representation of it in one byte. To give the application better control of how the keyboard is actually used, you have to enhance input capability.

BYTE: How is transfer to the screen handled under the GIOS?

Sutton: There isn't blocking of data, but there are high-level operations such as polygonal fill and vector drawing. These are all handled as single operations, so logically you might consider that blocking of data. I can specify a polygon and fill it, and I don't have to send all the vectors to do the fill. A variety of fill patterns

and line styles are all built directly in as GIOS functions.

Lee: Most operating systems are basically designed so that you have a computer and two wires talking to a terminal. You view console I/O as talking serially to a terminal outside of the computer, and that basically is a low-bandwidth path. We wanted a path whereby data goes out in a parallel fashion. The AIOS and GIOS achieve that.

Sutton: We can frequently write the entire screen in the blink of an eye. With that capability I don't have to wonder about algorithms that will rewrite the precise part of the screen that's changed. We've found that using the I/O structure simplifies a number of the programs that we do. For example, in our extended version of Visicalc, we don't write the whole screen; we're more intelligent than that. We write columns when the screen scrolls because we can write a column as a block on the screen. And we can do the things very rapidly. A trick we haven't made use of, but which I'm sure is awaiting exploitation in some future product from us or an outside vendor, is to make use of the two separate planes

of screen memory. If you are doing something in a graphics application and all your menus are completely active in the alpha plane, bringing up a menu just consists of turning on the alpha plane. This means you can fill an entire screen with a touchscreen menu instantaneously. And as quickly as the person touches the item of interest on the menu, the menu can disappear, leaving the graphics intact on the screen. The I/O structure suggests a number of novel uses.

BYTE: You did your work in Pascal. Did you consider other languages?

Sutton: Actually, we did consider and used other languages for that matter. We actively considered using Pascal from a number of independent vendors instead of the Pascal from the HP 3000 and considered using C as a language.

BYTE: Why did you choose Pascal over C?

Sutton: There are a variety of reasons. We like to get a great deal of the work done inside HP in a standard language so that it's easy to port around to other environments. For example, our Visicalc will be available on the 3000. And that's because we were able to write the program once. Then with changes to the I/O structure going to the screen, we were able to make that product run on both machines.

To be frank, we also wanted to have control over the quality of the language. If things turned out to be generating code that was too large for us, we knew we could go in and optimize the compiler.

Some of the utility programs in the system are written in C, but for utilities specific to the 150, it wasn't important to have a language with great porting capability. It made more sense to choose a language for other considerations, such as generating smaller or faster code.

BYTE: Is P.A.M. the utility that you're talking about?

Sutton: Part of P.A.M. was written in C and part in HP Pascal.

BYTE: Will you be able to write programs that use the touchscreen in any language?

Sutton: Any language can use touch already. There's nothing magic about

touch. The touchscreen is controlled at the simplest level by escape sequences. I send those escape sequences just as if I were, if you will, printing them. And if I know what the escape sequences are, I read in my manual the escape sequences to activate a touch area at some certain area, then I can do that in any language.

BYTE: How did you decide what percentage of the resources, including memory, would be devoted to ease of use? How important was ease of use?

Sutton: We wanted to differentiate the 150 from other products in this marketplace, and ease of use was one of the critical differentiating factors,

It has always been our goal to use popular software packages and to develop some of our own.

which is one of the reasons, of course, that we settled on the touchscreen.

We have a fairly formal procedure at HP for passing external specifications through a rigorous review process before the product is actually started. But I don't think we made a conscious decision during that process as to what amount of resources we would devote to ease of use. Our most important constraints, I think, are memory and disk size because we want everything to run on our smallest-capacity disks. Those are important constraints, and some ease-of-use features do take machine resources. For example, we wanted to prevent the possibility of invalid input. I think it's quite easy to enter invalid inputs and have the machine not object to them in some of the products we see on the market. The machine may not blow up, but it will do something that is inconsistent with the inputs. To us, ease of use is important in things as small as that to things as large as using the touchscreen. It all takes effort and code and size.

BYTE: Did you know from the beginning that you wanted to use popular software packages on your machine?

Sutton: Yes; that has always been a goal.

BYTE: When did you decide to also develop some of your own software?

Sutton: That's always been involved in the machine also.

BYTE: To what degree do the applications transfer data among them?

Sutton: We have modified existing applications or worked with vendors to modify the applications to use the high-speed I/O and touchscreen features, and also, in a more limited way, to have the ability to move data back and forth. We've often reworked our own applications to facilitate the data transfer. For example, our own card-file package has been tested to make sure that its data can be transferred to and from the Condor database package. In the same way, we've made sure that our own Memomaker editor is able to transfer data between itself and word-processing packages from outside vendors. We facilitate the transfer by using outside vendors' file formats directly or by having easy ways to get between our format and theirs.

BYTE: You can move information between the Personal Card File and Condor and between the Personal Card File and Wordstar's Mailmerge program. Did you try for greater data transfer?

Sutton: Yes. Our inability to do a greater degree of data transfer is in some sense a limitation of MS-DOS. One reason we thought about building our own operating system was that we knew that with it we could give the appearance of integrating separate, independently written programs. We may yet be able to accomplish that through other mechanisms or through future releases of MS-DOS.

To transfer data among our own applications, we have a mechanism that might be considered similar to Unix pipes.

BYTE: What functions does the file manager provide for applications?

Sutton: Well, fundamentally, it provides consistency across all applica-

When Performance Is A Factor...

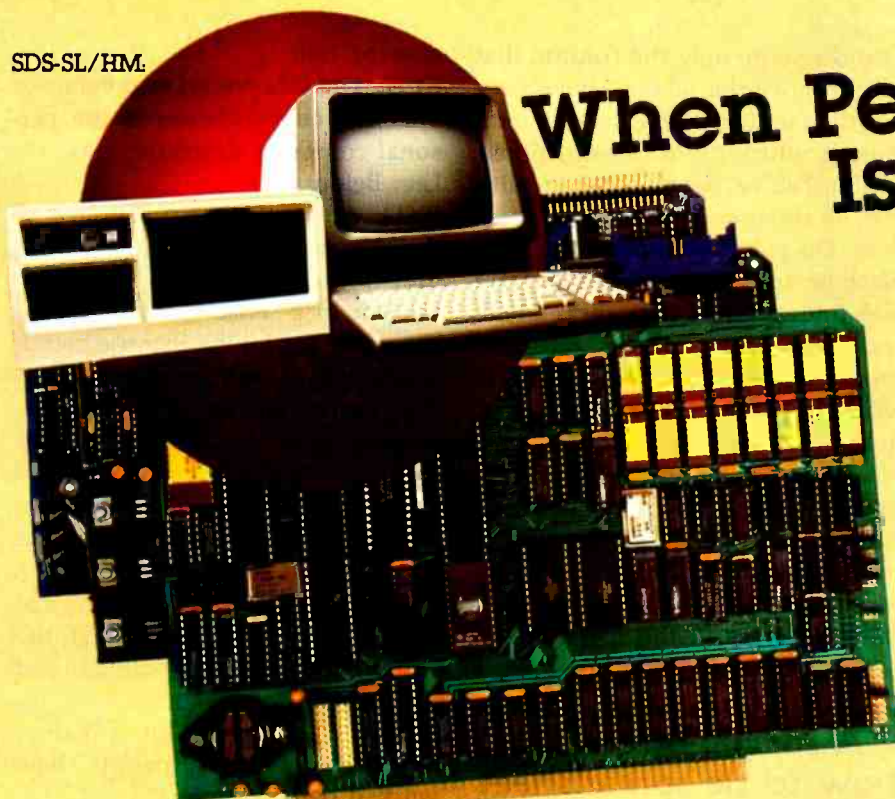

Winchester/SMD Hard Disk Controller

(Shown with Sierra's new 8MHZ Boards)

This is an amazing high-speed companion for your single-or multiuser system. Features NEC's new hard disk controller chip, on-board Z80 processor, buffered sector heads, full ECC supported, SASI or SMD versions available, and optional high-speed DMA pass-thru port for use on Sierra Data's new 8MHZ Master/Slave.

8MHZ-SBC Master and Slave Boards

Now, from a Z80 processor, the most incredible throughput available today in the S-100 industry! As the powerful nucleus of a Sierra Data-supported CP/M 2.2* or 3.0* system, our master makes any system look good. With networking TurboDOS* and our new slave, the results are absolutely unbelievable. Check these features (M-master, S-slave):

- Z80H (M & S) Z80A (M optional)
- Dart, 2 serial ports (M & S)
- PIO, 2 parallel ports (M & S)
- CTC, 4 counter timers (M & S)
- From 64 to 512K on-board RAM (M & S)

- 8232 Math Processor (M & S)
- 4K/8K/16K EPROM (M & S)
- Meets IEEE-696/S-100 Standards (M & S)
- NEC 765 Floppy Disk Controller-controls 8 in. and 5 1/4 in. floppy drives simultaneously (M)
- Multiple Master Buss Arbitration (M)
- DMA Controller (M)
- High-speed Winchester DMA port (M)
- 4K static RAM 8/16 bit independent bus transfer circuit (S)
- Either one or two users per slave under TurboDOS* (S)



SBC-100 and SBC-100S Boards

The workhorses of the single-board computer industry. At 4MHZ these totally IEEE-696 compatible champs out-perform even the 6MHZ imitators. In standalone or slave-satellite configurations you get dedicated Z80A processing with 64K RAM, 4K EPROM, 2 serial RS-232 channels, 2 parallel channels, 4 counter timers and a host of floppy and hard disk

interfacing options. Teamed up with Sierra-supported CP/M 2.2* or networking TurboDOS* you get the most computer power and upgradability for the money.

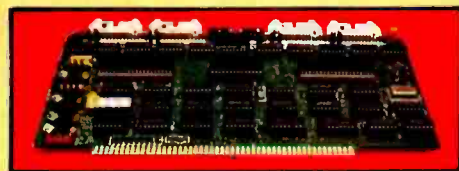

ZSIO-4

A powerful four-port RS-232 serial I/O and real time clock board. Zilog SIO-chips provide ideal links to CP/M-MPM and AlphaMicro-based systems for multiuser processing with high speed data communications.

Out-perform your competition with a company that stays a step ahead. Ask for our free "Performance Building Kit" today.

216-892-1800

HARDWARE
SOFTWARE



SIERRA DATA SCIENCES

Fresno, CA
Product Support Division • 25700 First Street • Westlake, OH 44145
(216) 892-1800 • TELEX: 980131 WDMR

*TurboDOS is a Registered Trademark of Software 2000 Inc.
*CPM is a Registered Trademark of Digital Research

tions, whether in-house or proprietary. The user has a consistent way to get at data and files on the system. So, for example, using the file manager, a person can readily view any directory on any disk, see that directory sorted in alphabetic order, and by simply pointing to a file cause that file to become the object of interest to the application. In addition it provides more functions—in fact, better functions—than conventionally available in packages like Visicalc or our previously existing graphics packages.

BYTE: How did you decide what enhancements to add to Visicalc?

Sutton: We looked at a number of spreadsheet packages that are available in the marketplace today, including the Advanced Visicalc package. Then we compiled a prioritized list of features we would like to see in the package. From that list we chose the features that we could accomplish in the time frame that we had for the product. We expect to continue adding important extensions to Visicalc. Our special interest right now is how to tie spreadsheet packages to a larger network environment.

BYTE: How did you speed up software written in high-level languages?

Sutton: Our approach has been to develop the languages in a fairly straightforward approach in the 3000 environment and to bring those languages across to the 150. We used the results of that as a basis for analysis on where we could tune and improve performance. First and most obvious was to modify all the I/O to use the AIOS/GIOS to improve performance. In addition, monitors tracked time we spent on particular blocks of code. We used this to determine where, for example, our run-time library might need to be optimized to make it faster. Sometimes the compiler itself needed to be optimized in some ways. Sometimes we could change our coding practices and make use of particular algorithmic features. For example, our first version of Visicalc wrote the full screen in MS-DOS vanilla screenwriting. Our second version of Visicalc wrote the full screen using AIOS. The third version

would rewrite only the column that would move the whole screen over and then write only the new column, both of which are AIOS functions.

BYTE: You've been working with lots of independent software vendors. Do you have a mechanism in place for looking at proposals from ISVs (independent software vendors) and from independent, one-man programming firms that want to write for the HP 150?

Sutton: We have a mechanism in place and a better one will certainly be on the way by the time this article appears. We are doing two things simultaneously. One is actively soliciting all the vendors of top software packages in the marketplace,

A special interest is how to tie spreadsheet packages to a larger network environment.

and the second is being receptive to the ideas of smaller vendors who desire to participate. At the moment, we have an ISV cookbook that helps vendors use all the features we've described. We also offer vendors technical support and the physical hardware.

In the future we will have parallel R&D and marketing activities: a complete R&D lab within the personal software division, whose entire orientation is toward helping ISVs develop software for this machine, and a parallel marketing organization helping from the marketing side.

BYTE: What was the hardest part of the whole project?

Sutton: The hardest part of the whole project for me was the fact that a lot of things that are normally done serially were being done in parallel. There were huge numbers of critical and interrelated decisions going on at once.

BYTE: When were you convinced it would really work as you had imagined it would all work?

Sutton: I'm a true believer; I always believed it would. The only variable

was the time.

BYTE: Did this project start before or after the consolidation of the personal computer division?

Lee: Before.

BYTE: And is this the first project of that division, or is this a project the division inherited?

Sutton: In a sense the division inherited it, but I think that the notion of the project was one of the things that caused the organizational restructuring of the company. I think that trying to decide your placement in the marketplace goes a long way toward dictating the structure of your organization, and that was true here.

BYTE: Was there a specific group of people who worked throughout the project, or were people pulled in and out of the Magic team?

Sutton: It was a little bit of both.

BYTE: How many people have worked on this project?

Sutton: About 50 R&D people are working on it now.

BYTE: Did people take the machine home to continue work, or did you keep it pretty well locked up?

Sutton: Lately people have been taking it home to work on. I know I took it home. My kids had a wonderful time playing with it. We will achieve great penetration in the 4- to 7-year-old market as well as in the business market.

BYTE: Was there a kernel of the team, a group of people who've been working only on this who will go on to another project as a team?

Lee: Not necessarily.

Sutton: I think in the software area that will probably be true. Our view of the software area has a longer range than this particular set of hardware. One of the purposes of forming the personal software division is to have compatible, consistent software across a range of products, both the products that are available now and in the future. ■

Phil Lemmons is West Coast Bureau Chief for BYTE. Barbara Robertson is West Coast Technical Editor. They can be reached at McGraw-Hill, 425 Battery St., San Francisco, CA 94111.

Solutions for success

Perfect Software, Inc.

Perfect

It's really two w systems

Powerful, automatic formatting plus simple on-screen editing.
Only Perfect Writer™ gives you both.

It does the work so you don't have to.

You probably don't want to know how a word processor works.

In fact, even setting margins, tabs, chapter headings, and other format details, is something you shouldn't have to worry about. That's why we developed automatic formatting for Perfect Writer.™ It's powerful enough to do much of the work for you, so you don't have to think about it.

Professional word processing in minutes.

You don't have to be an expert to produce professional word processing in minutes. Perfect Writer™ supplies over 100 commands for instant results formatting your document. Set tabs, align margins, adjust spacing or indent and number lists — all automatically. For business letters. Memos. Reports. Technical

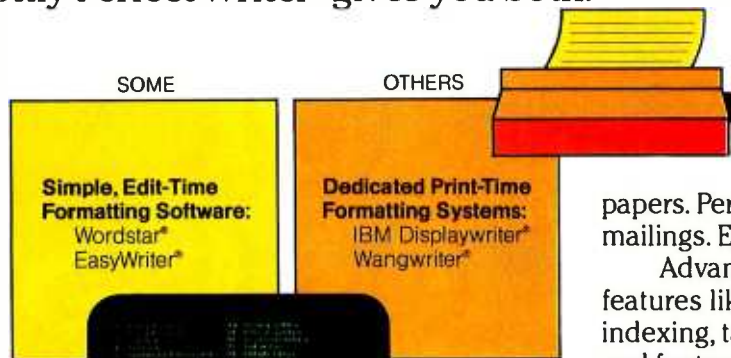

papers. Personalized mass mailings. Even books. Advanced formatting features like automatic indexing, tables of contents and footnotes are built in.



Only Perfect Writer™ BOTH
Simple, on-screen formatting
Automatic print-time formatting.

Simple on-screen editing.

What if you have a special format in mind? A quick note or document design you may want to use only once? No problem. Perfect Writer™ also includes simple on-screen editing and formatting — just like the system you're probably most familiar with. Your printed

document will look exactly like the document you design as you write. What you see is what you get.

Some expensive dedicated word processing systems offer automatic formatting features. Others offer simple manual screen formatting. Only Perfect Writer™ gives you both.

Document Formatting

Print-time formatting
AUTOMATIC:

Just write. Perfect Writer™ does the rest for you. Document design formats such as footnotes, indexing, tables of contents, and report formats — they're all automatic.

Screen formatting
MANUAL:

What you see is what you get.
Manually control the screen and print exactly what's there.

Only Perfect Writer™ does both!

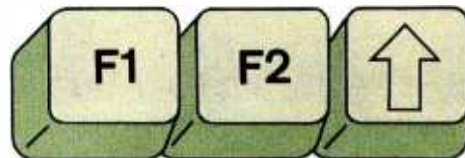

Full-power function keys.

All Perfect Software™ programs can be configured to take best advantage of the sophisticated features offered with today's computers and smart printers.

You can use all of your function keys — including the more than 50 function keys on the IBM-PC.® Perfect Writer™ fully utilizes printers with proportional spacing, too. Print with a choice of up to six typefaces!

Writer™

word processing
in one.

Finally. A word processing program
for any computer in your office.

Perfect Writer™ is the most compatible word processing program.

Everything you compose with Perfect Writer™ — every chart, every table, every document, everything — can be used by virtually any other word processing program or dedicated system.

That's because Perfect Writer™ uses true ASCII data files to store your documents. ASCII is the computer industry's standard information code. It's read and recognized by computer systems worldwide, regardless of disk format or size, whether it's used locally or sent over telephone lines.

Spreadsheets can be included.

Want to illustrate your Perfect Writer™ document with a financial table or graph that's stored in a Perfect Calc™ spreadsheet? You can — easily. In fact, you can even edit the numbers for your Perfect Writer™ document without disturbing the original Perfect Calc™ spreadsheet. That's Perfect Software's™ fully integrated programs at work.

Split screen editing.

You can view and edit two documents on the screen at the same time with Perfect Writer's™ unique split screen feature. One simple command moves you easily between documents. And you can even review a spreadsheet while editing up to six other documents! It makes the preparation of complex documents easier than ever before.

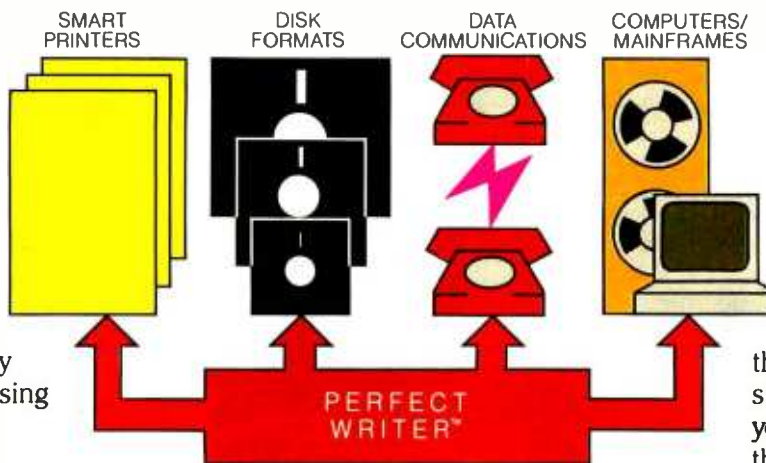

Check your spelling as you write with Perfect Speller.™

Perfect Speller's™ in-text spelling checker finds spelling errors and typos at a rate of 4,000 words per minute. (That's 20 pages every three minutes!) Then, at a single command from you, Perfect Speller™ lists the misspelled words or marks errors in the text of your document.

Self-teaching software makes it easy.

Perfect Writer's™ document design tutorials are matched to the easy-to-read user guide. Eight lessons are included. Learn how to handle form letters, how to write business correspondence, and how to create your own special spelling dictionary. All tutorials are software-based, interactive programs to make learning easy and fun.

Available for all IBM-PC DOS®, CP/M®, and MS-DOS® operating systems.

When you upgrade to new hardware, Perfect Writer™ keeps right on working. All text files are transferable. No other software works with a wider range of personal computers. In fact, Perfect Software™, now available for all of the most popular 8- and 16-bit computers, will soon be available for 32-bit formats as well.

Only Perfect Writer™ offers you this much flexibility. Write your own success story today. With Perfect Writer.™

Perfect Software, Inc.
Solutions for success

Perfect

Up to seven associated spreadsheets plus multiple views

For successful solutions in financial planning.

Perfect Calc™ makes it easy.

Perfect Calc™ gives you the financial planning and analysis tools for success. Automatic associated spreadsheets. Built-in accounting and financial tools. Easy commands.

And only Perfect Calc™ features on-line associated spreadsheets plus split-window display.

With Perfect Calc's™ multiple window display, you can see two different spreadsheets at the same time. Change your figures and see how the resulting variations affect each spreadsheet. Up to seven spreadsheets on-line at once.

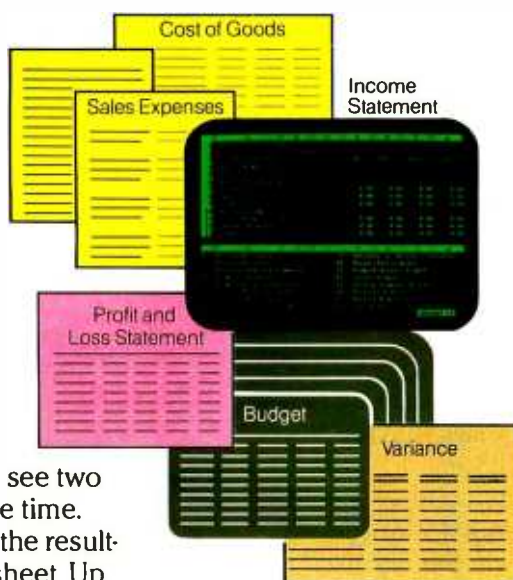

How Perfect Calc's™ multiple file association really pays off.

A good example is the built-in Income Statement Program. The income spreadsheet automatically reads from three other spreadsheets: Cost of Goods Statement, General and Administrative Expenses Statement, and Sales Expenses. All four are on-line simultaneously. All you do is fill in the blanks.

Then use all that information to perform an instant analysis and illustrate the results of potential budget cuts or increases. You change just one spreadsheet using the fill-in-the-blanks style. Perfect

Calc™ automatically takes care of the rest.

Multiple Spreadsheets

Associated spreadsheets

AUTOMATIC:

No double work — use any information you choose simply by referring to other spreadsheets. Move information, formulas or whole spreadsheets freely between multiple spreadsheets. Permits fill-in-the-blanks automatic forecasting and planning. Sixteen built-in application programs are included.

Spreadsheet consolidation

MANUAL:

Simple cut-and-paste spreadsheet entries. Line, column, or whole spreadsheet additions from any one of seven on-line spreadsheets are also easy with Perfect Calc.™

Only Perfect Calc™ does both!

Setting up the Perfect™ spreadsheet!

Entering titles, labels, and additional information on your spreadsheet is easy with Perfect Calc.™ It recognizes words automatically and handles them correctly without any special commands. If you want to use numbers — like dates — for item labels, that's easy, too.

Individually variable column widths add flexibility in setting up your Perfect Calc.™ spreadsheet. And once you've developed one spreadsheet, you can use it as a template for other applications. Simply refer to it.

Self-teaching software.

Easy, software-based lessons are included to make learning spreadsheet techniques simple. The lessons are matched to guides in the user manuals so

Perfect Calc™

Automated spreadsheets Window display.

Sixteen applications built in. And that's only the beginning.

you can follow along in the text. Because you learn on the computer at your own pace, there's no pressure to perform. Try new applications when you are ready.

The most complete applications.

Perfect Calc™ is the only spreadsheet you can buy with 16 applications built in. Standard paper and pencil financial tools are ready to use. All you do is fill in the blanks.

Just a simple command is all you need to start working. And on-screen tutorials and English prompts give you assistance whenever you need it.

Handy cursor commands.

You can move the cursor easily to the top of a column, beginning or end of a line, to the page before or after—with a single command.

And you can go back and forth between two spreadsheets on split screen display with just as much ease. That makes multiple spreadsheet handling easier than ever before.

The most compatible spreadsheets.

Perfect Calc™ data is stored in true ASCII files—the files read and recognized by every computer system. So, it's simple to use a Perfect Calc™ spreadsheet in a Perfect Writer™ report or letter. Or, build graphic displays using the information in one of your spreadsheets.

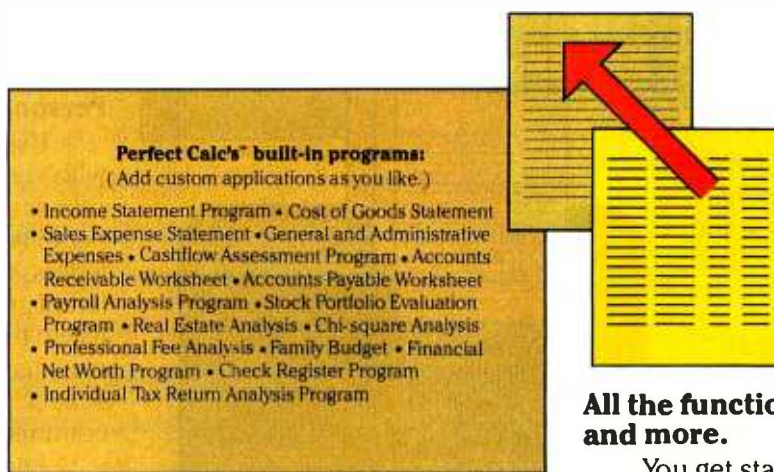

All the functions you need—and more.

You get standard functions for financial, scientific, and engineering applications plus an expandable functions library which allows you to add new formulas as you like. Write your own complex applications programs. Just use a Perfect Calc™ spreadsheet and take advantage of the powerful associated files feature.

Put the solutions for success to work for you.

Using simple plain-English prompts and on-line references, you can do sophisticated forecasting and planning in minutes.

Automatic associated spreadsheet information management. Standard spreadsheet calculation and consolidation. Only Perfect Calc™ gives you both. Start planning for success today with Perfect Calc.™

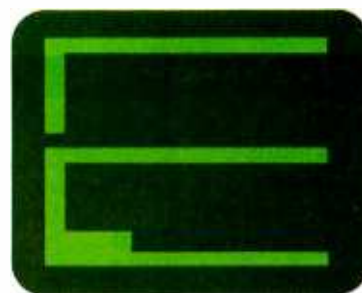

Perfect Software, Inc.
Solutions for success

Perfect

For successful manag

The powerful records management solution
for the personal computer user.

Put information to work for you.

Most information management systems are either too small or too difficult to use. Now there's Perfect Filer™, the executive information management system that's easy to use. You can keep track of mailing lists, clients, sales, merchandise, names and addresses, and much more.

Easy to get started.

Two ready-to-use data entry forms are provided so that you can begin using Perfect Filer™ immediately. One is for individuals, the other for companies and organizations. You type important information just once. Perfect Filer™ does the rest for you. No special training is required. In fact, your entire staff can use it.

On-line references and English prompts provide



INSTANT DATA BASES AND REPORTS

assistance when you have questions. And tutorials are included for improving your skills.

Personalized form letters.

Use Perfect Filer™ together with Perfect Writer's™ word processing features to add a personal touch to mass mailing letters. You can even tag different groups within one mailing list so that your letters to them can include special paragraphs, subsections or operator-typed comments.

And Perfect Filer™ remembers nicknames, titles — even your special salutation for special clients or friends.

Generate mailing lists.

Form letters. Specialized record-keeping forms and sorted lists. Choose from the two data entry forms provided or from seven data entry groups.



Creating custom data bases has never been this automatic.

Single-keystroke data entry menus do the work for you. You enter your data just once on a blank Perfect Filer™ data entry form — whether it be client addresses, direct mail sorting codes, payment records, inventory, or standing orders.

Successful information management. Perfect Filer™ makes it simple.

Information Management

Data entry forms
AUTOMATIC:
To create your own records file,
just enter information on the convenient
on-screen form. All of the parameters
are predefined.

Information management
MANUAL:
Create custom data bases with ease.
Build an entirely new structure,
or "borrow" data entry groups
from existing formats.

Only Perfect Filer™ offers you both!

Perfect Filer™

Information Management.

The integrated software solution.

When you learn one program, you've learned them all.

Perfect Software™ All of the most-asked-for business and personal computer applications in one complete package. Word processing. Financial planning. Mail management. Records keeping. Perfect Software™ provides the solutions to those everyday business problems.

Each Perfect Software™ program works smoothly and efficiently with the others. All share common file structures. And, all use the same command con-

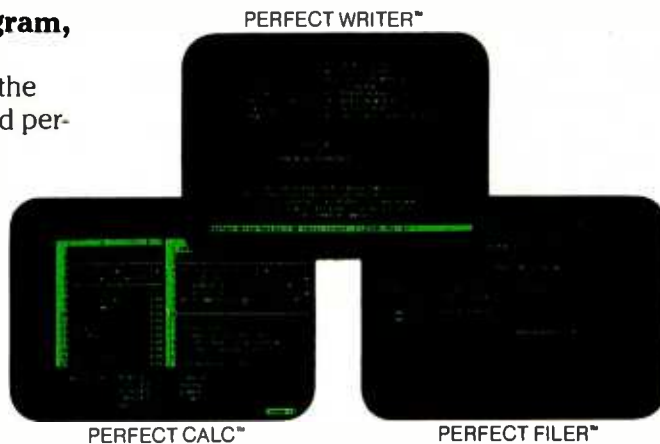

Solutions for success.

You get more performance, more flexibility and more automatic functions with Perfect Software™ than with conventional software packages. So, you save time and effort. And Perfect Software™ programs are self-teaching and fully interactive, for productivity plus convenience.

Perfect Calc™ provides unmatched spreadsheet performance. Perfect Filer™ is a records management powerhouse. Perfect Writer?™ Rated #1 by *Personal Computing*; given highest marks by *Info-World*; and called "the most comprehensive word processing package" by *Esquire Magazine*.

Perfect Software™ Your solutions for success.

The Rebate. \$160.00.

Now, for a limited time, personal computer users can get back \$50 each on Perfect Writer™ and Perfect Calc.™ And, \$30 each on Perfect Speller™ and Perfect Filer.™ That's \$160 factory direct to you when you buy all four Perfect Software™ programs.* Act now. Offer expires October 31, 1983.

Perfect Software, Inc.

Solutions for success

702 Harrison Street, Berkeley, CA 94710

Perfect Software, Perfect Calc, Perfect Writer, Perfect Filer, and Perfect Speller are trademarks of Perfect Software, Inc. IBM-PC and IBM-PC DOS are registered trademarks of International Business Machines. CP/M is a registered trademark of Digital Research, Inc. MS-DOS is a registered trademark of Microsoft.

*Purchases made as a part of computer manufacturer's original equipment offer do not qualify. Void where restricted by law. See in-store display for details.

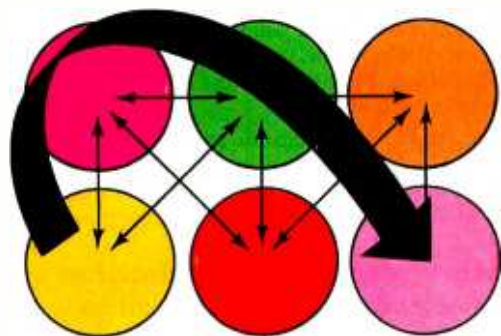

figurations. So, learn one program and you can use them all.

Only Perfect Software™ offers you this much.

Perfect Software™ works with IBM-PC DOS®, CP/M®, and MS-DOS® operating systems as well as most 8- and 16-bit computers. And each Perfect Software™ program is power packed with extra-value features, including:

- Common control commands.
- Manual and automatic functions.
- Self-teaching software.

Circle 361 on inquiry card.

This One Decision Saved our Business and Grossed over \$1,000,000. in Sales

In 1979, our recreational manufacturing business was booming. And we had developed a new product that looked like a real winner. The new product was extremely important, in that it appeared to be the answer to a seasonality problem associated with our other product lines.

By early summer, our order book was bulging. It really looked as if our off-season sales and production problems were over. Then just as quickly the roof fell in. Gas shortages devastated the recreational vehicle market overnight. And our order book for over two million dollars worth of the new product disintegrated.

Faced with a fall and winter of virtually no sales, many thousands of dollars of unneeded parts and excess production staff, I had no choice but to shut down the production lines. And if a solution to our problem could not be found, the business itself was in jeopardy.

A life saving decision

I spent many sleepless nights trying to come up with a solution to this nightmarish situation. Then I remembered a course I had taken in decision analysis. I spent the rest of that night reviewing course material and other books I had bought on the subject. The next day, I called an emergency meeting. Using the decision making techniques I had learned, we spent the rest of the week searching for and analysing potential solutions. The net result was that not only was the company pulled back from the brink of destruction, but we added over \$1,000,000.00 in gross sales during that off-season.

A way of life

From that point on, almost every critical decision (and there were many) regarding new products, marketing channels, pricing, advertising, production equipment, engineering projects, received this same type of analysis.

Although the process was very time consuming and clumsy, because it had to be done by hand, our decisions were much improved. And there were some real benefits that we had not anticipated.

1. Our understanding of each problem was greatly increased.
2. We uncovered opportunities that we would not have thought of in any other way.
3. Our decisions were documented, preventing us from slipping off the selected path or 'rehashing' the same things over and over.
4. Consensus became easier because we were forced to focus and resolve each part of the problem, one piece at a time.

The birth of Decision~Analyst™

Decision~Analyst was created because the process of evaluating complex decisions with multiple alternatives and many criteria is very tedious and time-consuming if you do it on paper. And doing it in your head is virtually impossible.

Any complex decision usually requires multiple revisions to criteria, alternatives, weights and values assigned to them. If done manually, the ordeal of rewriting, recalculating and redocumenting tends to discourage revisions, thus producing poor results.

Decision~Analyst overcomes these problems by asking for the minimum input possible from you, in the correct sequence. It leads you step by step through the decision making process, then does all the necessary calculations and produces polished reports without any further effort. And all of your input is stored on your disk so that revisions and updates can be made easily at any time.

Comprehensive but easy to use

Decision~Analyst is probably the easiest program you'll ever use. You can literally learn to operate the program using only the 'help' screens. But it comes with a thoroughly indexed manual which includes many pages of examples plus a step by step guide to the decision making process.



And Decision~Analyst is no fly-weight. It uses over 100,000 bytes of fast compiled code and a 40,000 character help file. The program is extremely 'bullet proof' and does all the work . . . you do the thinking. And there is no danger of missing a critical step because your analysis is guided through each of the eight menu-driven sections.

Endless opportunity for use

If you're saying to yourself that you really don't have any earth shattering applications for Decision~Analyst . . . then consider this.

If you're in-business, chances are that the most important thing you do is make decisions.

Decision~Analyst can help you select key personnel, decide on new machinery or equipment, prioritize major projects and allocate resources, choose a new product or a better price strategy, select new offices or plant locations, select the most profitable marketing channel or the best piece of computer hardware or software. Use it to analyse any decision which has more than one viable alternative.

In your personal life, it can help you choose the best job, select the right business, career or franchise, determine the best field of investment or even the right home, boat or car. In fact, improving your decisions is probably the most rewarding thing you can do.

Let us help you make a \$139⁰⁰ decision

If there's a chance that Decision~Analyst could help you improve even one decision, would it pay for itself? Chances are it would. In fact, it's likely that it could save you the price many times over!

So why not take advantage of this special \$139.00 introductory price (plus \$5.00 shipping) by calling us today? We'll even refund your money, within 30 days, if you're not completely satisfied.

Decision~Analyst requires a CP/M or MS-DOS operating system, 52K of RAM, a 24 x 80 column screen and an 80 column printer for your reports. Order by calling collect to . . .

Executive Software Inc.

705-722-3373

Dept. DR 028

DA5

Two North State Street, Dover, Delaware 19901

© CP/M is a registered trademark of Digital Research Inc. © MS-DOS is a registered trademark of Microsoft Corp.™ Decision~Analyst is a trademark of Executive Software Inc. * Copyrighted 1983 by Executive Software Inc.

Build the Micro D-Cam Solid-State Video Camera

Part 2: Computer Interfaces and Control Software

Serial interfaces for the Apple II and the IBM Personal Computer and versatile software for the Apple II

by Steve Ciarcia

Last month I introduced you to the Micro D-Cam, a relatively low-cost direct-output digital camera that you can build, either from scratch or from a kit distributed by The Micromint. Using a 64K-bit dynamic memory chip as its optical sensor, it has a resolution of 256 by 128 pixels (picture elements), which is adequate for many applications, including input of graphic images, pattern and character recognition, robotics, process control, and security.

In part 1 I explained the principles of operation of the IS32 Optic RAM (random-access read/write memory) and the rest of the Micro D-Cam's hardware. (Table 1 may help you recall some of the IS32's characteristics.) This month I'd like to finish the project by discussing how the camera can be attached to the expansion buses of the Apple II Plus and the IBM Personal Computer and how the camera is programmed to work.

The amount of software included with this article is somewhat more than you've come to expect from a hardware-type fellow like me, but I feel it is necessary to properly show

how software can be used to enhance the final picture. In particular, some of you may be interested in the method used to present a gray scale on an Apple II computer.

A Quick Review

The IS32 Optic RAM from Micron Technology Inc. is a memory chip specially packaged to function as a digital image-sensing device. (Because its output is a pure digital signal, it cannot be used to directly drive a composite-video monitor.) The IS32 contains 32,768 usable light-sensitive elements arranged in a matrix of 128 rows and 256 columns. Each of the elements in the matrix is a light-sensitive capacitor, a memory cell that can be accessed randomly by simply reading in the appropriate

row and column address. Light striking a particular element causes the capacitor, which is initially pre-charged to a fixed voltage, to discharge toward 0 volts (V). The capacitor discharges at a rate proportional to the light intensity throughout the duration of the exposure. When the cell's content is read, a logic 0 remaining in the cell indicates a bright pixel—the capacitor was exposed to a light intensity sufficient to discharge the capacitor past the threshold point. A dark pixel is indicated by a logic 1 remaining in the cell, which happens when the light intensity is not sufficient to discharge the capacitor past the threshold point.

The operation of the image sensor can be compared to the function of film in a camera. The user can regulate the exposure by two adjustments: aperture (f-stop) and shutter speed. The aperture adjustment controls the amount of light that is allowed to expose the light-sensitive medium (either the IS32 or the film emulsion) by mechanically widening or narrowing the hole through which the light passes. The shutter speed (or scanning speed in the case of the IS32) dictates the amount of time the sensitive medium is exposed.

1. two 128-by 256-element arrays each measuring 5.504 by 1.088 millimeters
2. element size: 8 microns by 9 microns
3. vertical center-to-center spacing: 21.5 microns
4. horizontal spacing: 8.5 microns
5. spacing between left and right arrays: 150 microns

Table 1: Specifications of the Micron Technology IS32 Optic RAM, a 64K-bit memory chip that has the extra talent of serving as a digital image detector.

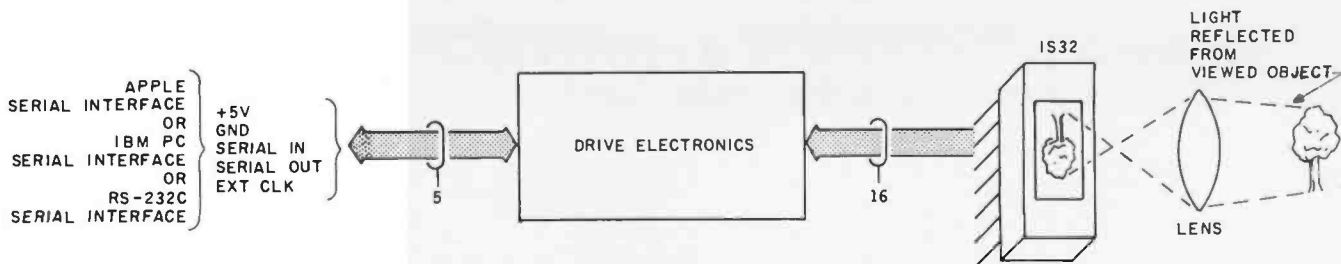

Figure 1: A block diagram of the Micro D-Cam system.

The Micro D-Cam's equivalent of an electronic shutter is controlled by commands transmitted to the interface. Sending a SOAK command to the Micro D-Cam has the effect of opening the shutter. After the appropriate period of exposure has elapsed, two commands, REFRESH and SEND, stop the exposure (close the shutter) and transmit the image to the host computer.

Interfacing the Micro D-Cam

Last month, when we looked at the control and driver electronics of the basic Micro D-Cam, we found that it communicates with its host computer serially, one bit at a time. In its minimal configuration, it requires four wires to be connected to the host computer: two supplying +5 V and ground potential and one each for serial data in and out. In a non-specific configuration, it can operate

asynchronously over an RS-232C link (at a data rate of up to 19,200 bps or bits per second), but I have devised serial interfaces for the camera that can be attached directly to the IBM PC and Apple II computers' buses (although still communicating serially). Using a fifth signal, an additional external clock signal provided to the bus interfaces by the drive electronics, the Micro D-Cam can then function at data rates up to 153,600 bps. The complexity of interface circuits of this type depends upon the host computer's bus structure and address range. The general scheme of connection is shown in figure 1.

Figure 2 is a schematic diagram of the circuit that forms the interface from the Micro D-Cam circuitry (shown in part 1) to the expansion bus of the Apple II Plus computer. It owes its simplicity to the predecoding of the I/O (input/output) slot ad-

dress already provided on the Apple's main circuit board. The address decoders usually required in a peripheral interface are eliminated, and the complete serial interface can be built with only two integrated circuits. The 74LS245 octal bus transceiver buffers the TTL- (transistor/transistor logic) level serial data into and out of the MC6850 ACIA (asynchronous communication interface adapter). The serial bit rate is controlled by the external clock output from the Micro D-Cam drive electronics. For maximum speed, the clock frequency should be set for 153,600 Hz.

Figure 3 on page 70 shows the serial interface circuit for the Micro D-Cam configured for the IBM PC's bus. Due to the greater complexity of the Intel 8088 processor as compared with the Apple's 6502 and the PC's larger memory-address space, the in-

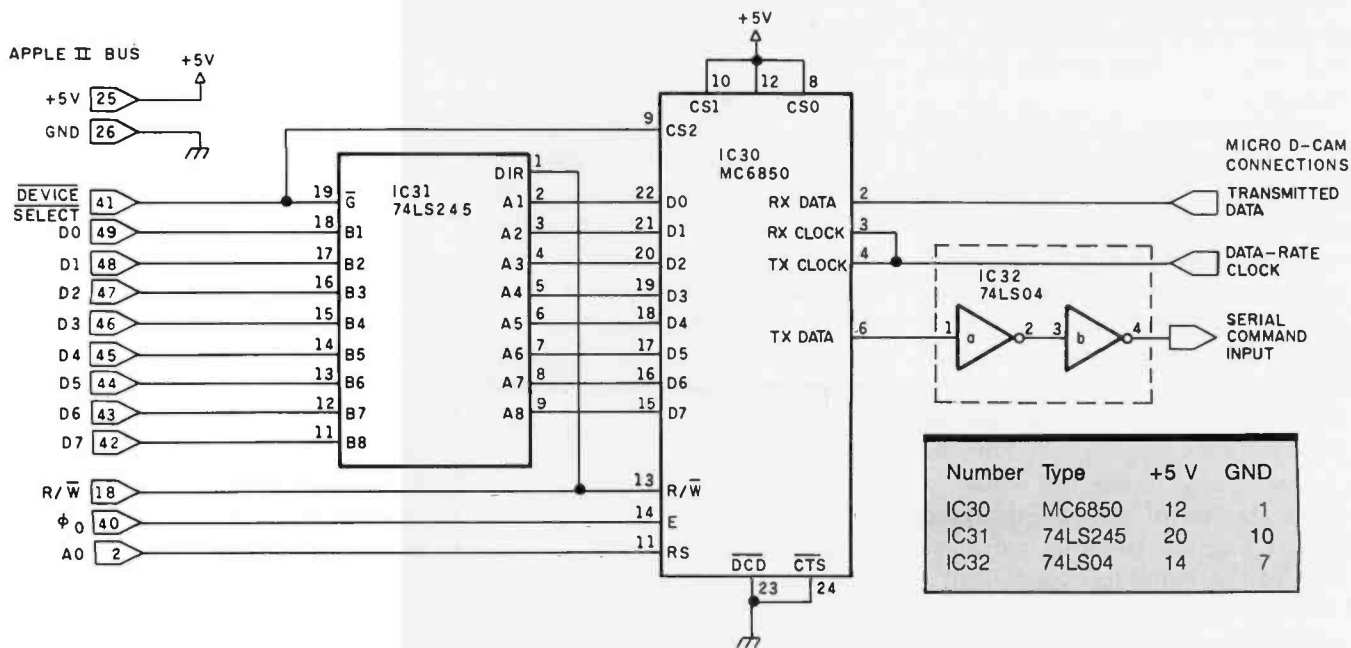

Figure 2: A schematic diagram of an Apple II Plus or Apple IIe interface for the Micro D-Cam. The serial data stream from the Optic RAM is converted to parallel bytes and placed on the Apple's data bus by the ACIA and bus transceiver. Although operating asynchronously, high data rates (up to 153,600 bps) are possible because of the external data-rate clock input from the camera-control circuitry.

In the Hard Disk Jungle Tallgrass Clears a Path



In today's hard disk jungle, Tallgrass clears a path by offering high performance, integrated mass storage solutions for the IBM® PC and compatibles, the T.I. Professional and the Victor 9000 computers.

TALLGRASS INNOVATIVE FEATURES

MASS STORAGE SYSTEMS with formatted HardFile™ capacities of 6, 12, 20, 35 and 70 Mb, all with built-in tape backup.

CONVENIENT INTEGRAL TAPE BACKUP SYSTEM allows rapid tape "image" streaming, or incremental file-by-file backup and restore on ANSI standard inexpensive data cartridges, instead of the usual floppies, video cassettes, or low-capacity removable Winchester devices.

NETWORK READY and fully compatible with networks such as PCnet® and EtherShare™.

HIGH RELIABILITY with dual directory and read-after-write verify options. A dedicated landing zone, where the read/write heads reside when the disk is idle, provides data protection during powerdowns and transportation.

EtherShare™ is a registered trademark of 3Com Corp.

PCnet® is a trademark of Orchid Technology.

IBM® is a registered trademark of International Business Machines Corp.

Follow the Tallgrass path to your local computer dealer and watch your personal computer transform into a powerful data processing system. From \$2,995.00 U.S. including integral tape backup.

Available from COMPUTERLAND®, Entré® Computer Centers, MicroAge® Computer Stores and other participating computer dealers.

New! IBM-XT Cartridge Tape Backup

World Headquarters: Tallgrass Technologies Corp. / 11667 W. 90th St. Overland Park, KS 66214 / 913-492-6002 / Telex: 215406 TBYT UR

Canadian Distributors: Micro-Ware / 440 Phillip St. Waterloo, Ontario N2L 5R9 / 519-884-4541

CompuServe / 1675 W. 8th St. / Vancouver, B.C. V6L 1V2 / 604-733-7783

European Distributor: CPS Computer Group, LTD Birmingham, England B276BH / (021) 7073866

Australian Headquarters: Tallgrass Technologies (Australia) / Five Dock Plaza Suite 12 / 50 Great North Road / Five Dock / Sydney, N.S.W. 2046 / (02) 712-2010



**Tallgrass
Technologies
Corporation**

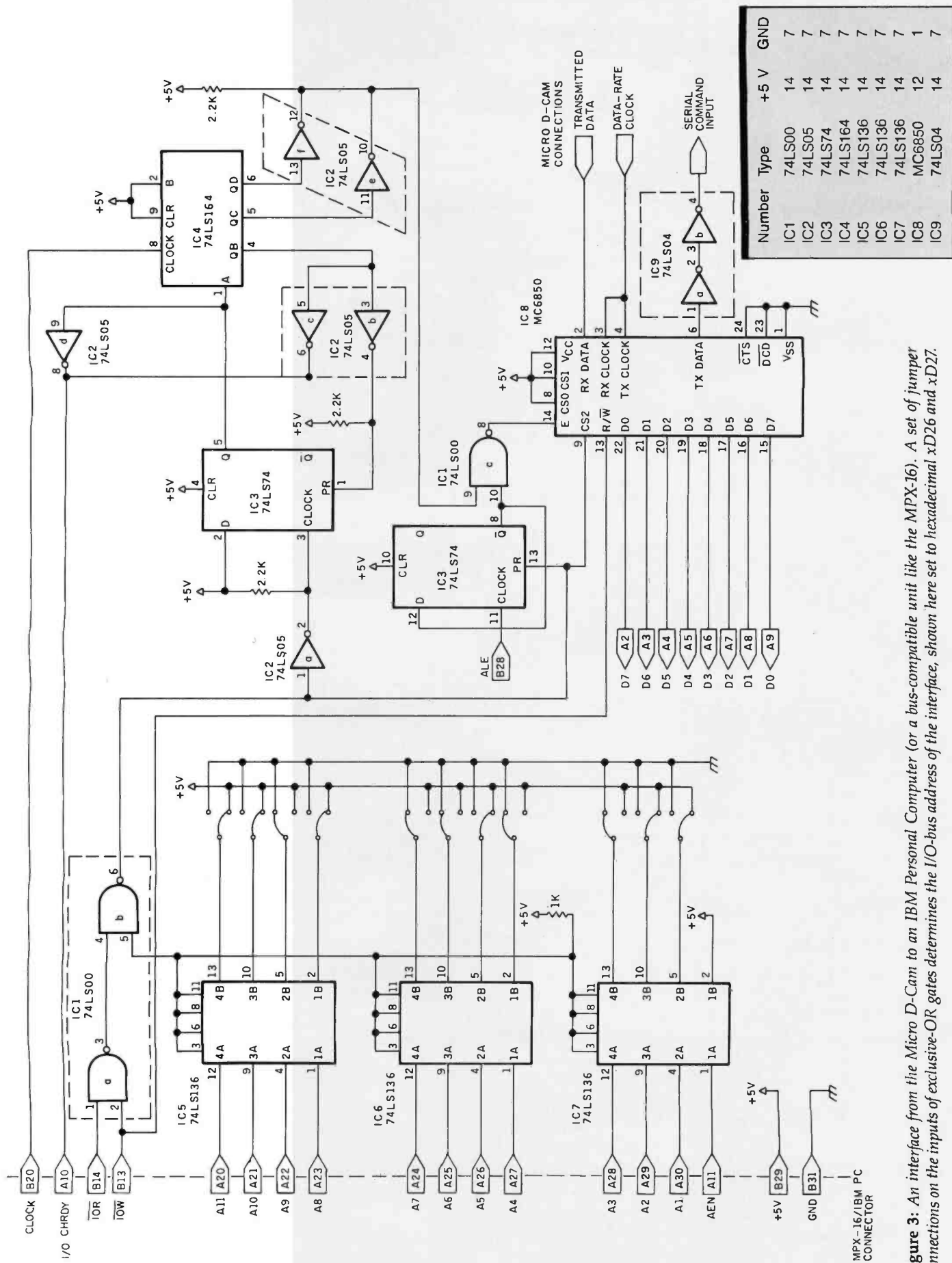

Figure 3: An interface from the Micro D-Cam to an IBM Personal Computer (or a bus-compatible unit like the MPX-16). A set of jumper connections on the inputs of exclusive-OR gates determines the I/O-bus address of the interface, shown here set to hexadecimal xD26 and xD27.



LAST NIGHT, 39 MUSICIANS HAD A COMPU SERVE CONFERENCE, SO DID 31 M.D.S, 49 SPORTS FANS AND 640 APPLE POLISHERS, AND NO ONE HAD TO LEAVE HOME.

The Electronic Forum, Cheaper than Long Distance and Much More Rewarding.

Every night on the CompuServe Information Service, professional and social groups discuss a wide range of subjects. From what's new in medical technology to what's nouvelle in continental cuisine.

And every day more computer owners who share a common interest are discovering this exciting new way to exchange ideas and even transfer hard copy data.

And besides electronic forums, they leave messages for each other on our national bulletin board, "talk" informally on our CB simulator, and communicate via CompuServe's electronic mail.

But best of all, in most cases, CompuServe subscribers get all of these state of the art communications options, plus a world of on-line information and entertainment for the cost of a local phone call plus connect time.

To become part of this flexible communications network, all you

need is a computer, a modem and CompuServe. CompuServe connects with almost any personal computer, terminal, or communicating word processor.

To receive an illustrated guide to CompuServe and learn how you can subscribe, contact or call:

CompuServe

Consumer Information Service, P.O. Box 20212
5000 Arlington Centre Blvd., Columbus, OH 43220

800-848-8199

In Ohio call 614-457-0802

An H&R Block Company

word is composed of 8 bits, with functions as summarized in table 2b. Let's look at each of these in detail:

ALTBIT Mode: When bit 5 is clear (equal to 0), the Micro D-Cam transmits only the pixels from the even-numbered rows and columns in the Optic RAM. This mode usually produces a clearer image than the NOALTBIT mode at the expense of losing resolution.

WIDEPIX Mode: When bit 4 is clear, the Micro D-Cam transmits each pixel in the array twice. Each image-sensing element is rectangular in shape, so by "double-transmitting" the pixels, the proper width-to-height (aspect) ratio is maintained when the image is displayed on the computer's video monitor.

7BIT Mode: The Apple II's implementation of high-resolution graphics is somewhat peculiar. The most significant bit of each byte on the hires graphics page is reserved as the color bit for a group of pixels, while each of the other 7 bits stores a 1 or 0 as a bright or dark value for a pixel. In 7BIT mode, the Micro D-Cam transmits data in a format compatible with the Apple's high-resolution format, with 7 bits of pixel values per byte. The 7BIT mode is selected by clearing bit 3 of the command byte to 0. The alternative to 7BIT mode is 8BIT mode, which is achieved by setting bit 3 to 1. The 8BIT mode causes the camera to transmit in normal bit-mapped format, with all 8 bits in the byte containing image data, and is preferred for use with all computers other than the Apple.

1ARRAY Mode: The 1ARRAY mode is selected by clearing bit 2 of the command byte. Using this mode, only data from the image focused on the lower light-sensitive array is transmitted from the Micro D-Cam. By setting bit 2 of the command byte, 2ARRAY mode is selected, which causes data from both arrays to be transmitted from the camera. The 2ARRAY mode causes a split-screen effect because of the space between the two arrays in the image-sensor chip.

REFRESH Mode: In some ways, the Micro D-Cam is like any other

(2a)	Status Bit	Meaning When Set to 1
	0	data has been received from the camera
	1	a command may be sent to the camera
	2	unused
	3	unused
	4	received data was improperly framed
	5	data received before previous byte read

(2b)	Command Bit	Meaning When Cleared to 0
	7	none (always 1)
	6	none (always 1)
	5	alternating-bit mode (ALTBIT)
	4	wide-pixel mode (WIDEPIX)
	3	7-bit data bytes (7BIT)
	2	transmit one frame instead of two (1ARRAY)
	1	refresh instead of soak (REFRESH)
	0	send the requested image (SEND)

Table 2: Meanings of bits in the status register (2a) and command word (2b) for the Apple II/Micro D-Cam interface.

terface requires three times as many integrated circuits. In the IBM, the Micro D-Cam's two port addresses are decoded by three chips: IC5, IC6, and IC7. These are 74LS136 open-collector exclusive-OR gates connected together in a "wired-OR" configuration. The voltages wired to the 11 inputs of the address decoder determine the interface board's addresses. As shown in figure 3, the addresses I used were xD26 and xD27 (where x can take on any hexadecimal value from 0 to F). The 6850 ACIA (IC8) functions as previously described except that IC2 and IC4 are configured as a wait-state generator to facilitate timely access to the bus.

Data and Command Format

The 6850 ACIA comprises a data register and a status register. You can configure operating parameters (such as parity, stop bits, start bits, clocking, etc.) by writing values into the status register. Before the host computer can access the Micro D-Cam, the ACIA has to be initialized to the proper configuration. The control software does this by writing two bytes, a hexadecimal 03 followed by a hexadecimal 14, into the status register. The first byte performs a master reset on the ACIA, while the second byte specifies that the serial transmission protocol is 1 start bit, followed by 8 data bits, followed by 1 stop bit.

Reading the status register allows the control program to determine when new data has been received and when the ACIA is ready to send data. The meanings of the status bits, when set, are as shown in table 2a.

In normal use, only bit 0 is checked when seeing if data is available from the camera. Bits 4 and 5 are used only in debugging, as these situations should not normally arise. When designing the program that receives the image from the camera, it is a good idea to incorporate a time-out mechanism in case the camera stops sending bytes before the program expects; otherwise, the program can hang up if the software misses even a single byte.

In the Apple II Plus and IIe, the hexadecimal addresses of the type C0nE access the status register of the ACIA on an interface card plugged into the corresponding slot, while C0nF addresses access the ACIA's data register. The n is the hexadecimal value of the slot number plus 8. For example, suppose the interface card were plugged into slot 3; 3 plus 8 equals B, and so address C0BE will access the status register and C0BF the data register.

Command Functions

While the camera is running, the host computer directs the Micro D-Cam's operating modes by sending it command words. Each command

More than a personal computer.



It's an accountant, word processor and financial planner. Now for only \$3,390 per user.*

No matter what business or profession you're in, ALTOS® has a desktop business computer system that can improve your efficiency—at a price that won't put you out of business.

For example, a typical Altos business solution includes integrated software applications for accounting (including a self-paced, step-by-step, built-in tutorial), word processing and financial planning. They're all easy to learn and use.

You can also choose from hundreds of other applications for attorneys, dentists, doctors, insurance agents, manufacturers, pharmacists, realtors and many more.

Altos systems are designed to grow as your business grows. You can start with a single user and add more users on the same system. Plus you can link hundreds together with a network.

And when you're ready, built-in features let you add more storage capacity, peripherals and communications—even electronic mail and appointment scheduling.

All of our systems are backed by responsive, nationwide service and support through the Customer Service Division of TRW, Inc.

So if your business or profession demands more than a personal computer can deliver, talk to Altos. Call, write or clip the coupon today for a free brochure and the name of your local Altos representative.

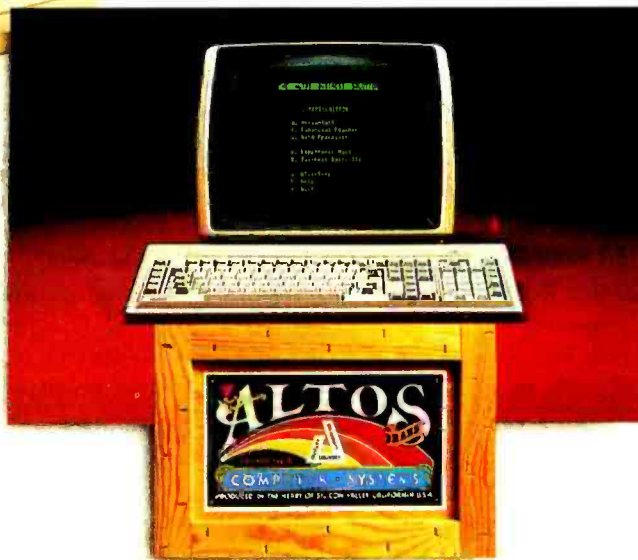

Packed with more value for business

- Please tell me more about the hundreds of uses for an Altos desktop business computer system.
- My application is _____
- Please have an Altos representative contact me.

Name _____ Title _____
 Company _____ Tel _____
 Address _____
 City/State/Zip _____

Mail to: Altos Computer Systems, Attn: Marketing Services,
 2641 Orchard Park Way, San Jose, CA 95134

800-538-7872 (In Calif., 800-662-6265)

In Canada, (416) 864-0740.

*Complete five user Altos system for \$3,390 per user or \$16,950. Price approximate and may vary in your area. Packaged system includes an Altos 586-10 hard disk computer with the XENIX™/UNIX™ operating system with the Altos "Business Command Menu Interface," five terminals, and the ALTOS ACCOUNTANT (with the built-in ALTOS COMPUTER TUTOR), ALTOS EXECUTIVE WORD PROCESSOR, and ALTOS EXECUTIVE FINANCIAL PLANNER applications. Price does not include printer, cables, installation, taxes, additional training and maintenance.

ALTOS is a registered trademark of Altos Computer Systems. XENIX is a trademark of Microsoft and is a microcomputer implementation of the UNIX operating system. UNIX is a trademark of Bell Laboratories. © 1983 Altos Computer Systems



Command Character	Control Effect
>	increase exposure time
<	decrease exposure time
F	fix exposure time to current setting
L	load previously stored image from disk
N	print negative of screen image onto Epson printer
P	print screen output onto Epson (Grafrax option required)
Q	quit and return to main menu
R	toggle display of exposure time and light level
S	save current image to disk
T	use current light level and autotrack the exposure

Table 3: Options for control of the Micro D-Cam that may be selected in real time through the distributed menu-driven software. See table 4 for the options provided in the GREY16 program.

camera. It must receive the proper amount of light to make the image develop properly. Too much light will overexpose the image, while too little light will underexpose the image. Exposure time is determined by how long the control program in the host computer allows the Optic RAM to be exposed to light without its cells being refreshed. Refreshing the image sensor is the same process used in any dynamic memory: the existing charge in each cell is sensed, the voltage compared with a threshold potential, and a fresh potential of 0 V (for a logic 0) or +5 V (for 1) is rewritten into the cell. (The only difference in the Optic RAM is that all cells must contain +5 V at the beginning of an image-sensing cycle when refreshing stops.) If the image sensor is not continually refreshed, the light focused on each cell causes the voltage in each cell to leak away at a rate proportional to the intensity of the light. When the image sensor is not being refreshed, we say it is "soaking" (in light). Allowing the image sensor to soak for longer periods of time enables the Micro D-Cam to see better in dimmer light.

When the REFRESH mode is selected (by clearing bit 1 of the command byte) the Micro D-Cam keeps the image sensor's cells refreshed while it is sending an image. When bit 1 is set, SOAK mode is invoked. This causes the camera to soak (and therefore remain sensitive to light) while it is transmitting an image.

SEND Mode: When a command is sent to the camera with SEND mode

selected (bit 0 cleared), the camera begins transmitting an image.

Control Software

The software for controlling and displaying pictures is vital to the operation of the Micro D-Cam. Menu-driven versions of the Micro D-Cam control software for both the Apple II and IBM PC are available from The Micromint.

However, some of you may already have the Micron Technology Optic RAM or a similar 64K-bit dynamic RAM device with suitable chip layout, and you may want to build the Micro D-Cam from scratch. Consequently, I have included with this article complete listings of two control programs written for the Apple II. One provides experimenters with a means for testing the Micro D-Cam; the second is a more sophisticated software routine that enhances the image and performs gray-scale ordered dithering (I'll explain this term later). While the Micro D-Cam software includes some additional menu-driven utility programs (some options of which are shown in table 3), all the Micro D-Cam photos printed here and last month can be reproduced using only the two programs in the magazine.

A Sample Control Program

The Micro D-Cam demonstration program (listing 1 on pages 512 through 518) illustrates the simplest possible software needed to receive an image from the camera and display it on the Apple's hi-res screen.

It is not really as long and complicated as it looks; the accompanying flowchart (figure 4 on page 76) should reveal the general scheme of operation. The software consists of two parts: a short BASIC main program (listing 1a) and a set of machine-language subroutines (shown in assembled format in listing 1b). The BASIC program loads the machine-language code from disk, interactively sets the correct I/O-slot number and exposure time, and calls the machine-language code to display the image; upon returning to BASIC, the calling program checks to see if you want to terminate the process.

The hard part of the work is done in the machine-language routines, which were necessary to allow the Micro D-Cam to operate at 153,600 bps. When called, the machine code begins by making sure that the hi-res screen is being displayed. It then initializes the ACIA and sends a command to tell the camera to soak without sending an image. (This effectively clears the Optic RAM and tells the camera to begin the exposure.) The program then waits for the duration of the exposure.

The next step is to read the image from the camera and display it on the screen. To save time and memory, the software sends the picture straight to the hi-res screen memory (rather than reading it into a separate buffer area and then moving it) to minimize the processing of the final image. The mode used is alternate-pixel, wide-pixel, with 7-bit data words. Before any part of the picture is received, a number of memory pointers are set up to facilitate proper placement on the screen. A command is sent to the camera to begin transmitting the image, and the program loops to read in each byte of the image and put it on the screen.

The control software knows how many bytes of image data it should receive from the camera, but a problem can arise from relying on byte-counting to determine when to stop reading data: if the computer misses one, it could hang the system up. To be on the safe side, a time-out loop has been provided in the image-reading routine. If the computer times out

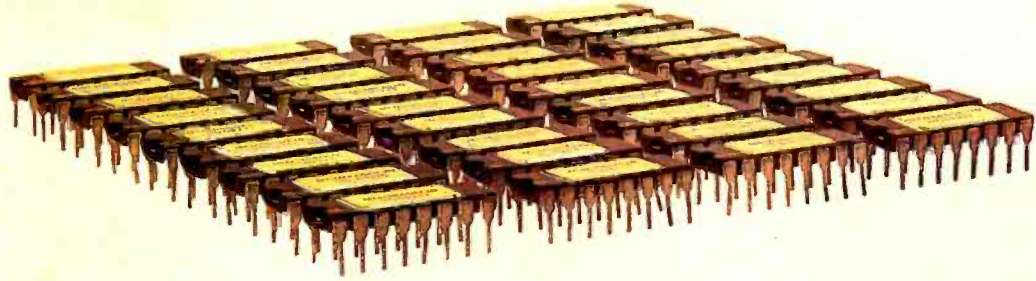

Fill in the blanks.

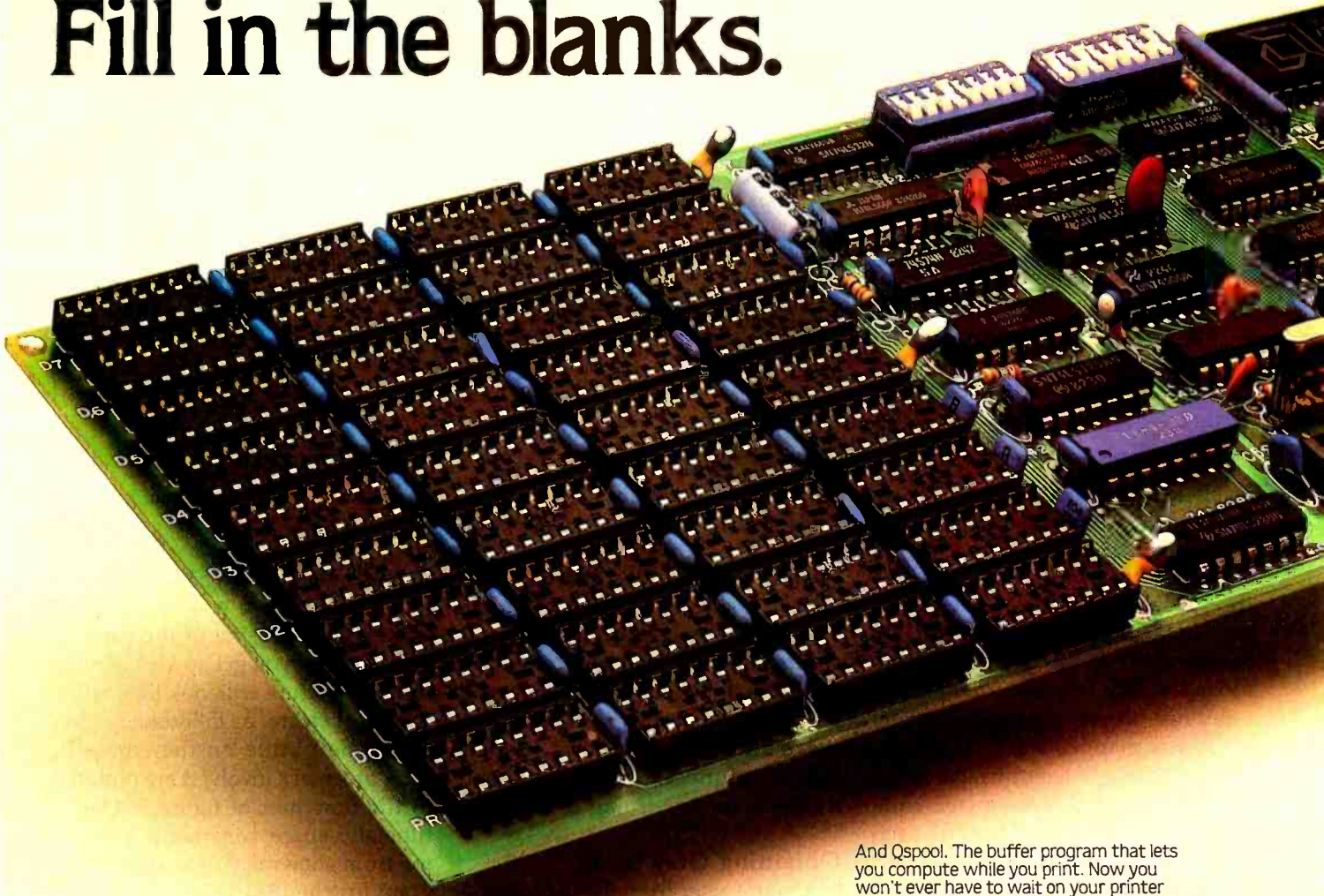

**QUADBOARD™
BY QUADRAM™,
NOW AVAILABLE
WITH NO RAM
INSTALLED.**

Quadboard, the world's best-selling multifunction board for the IBM Personal Computer, now boasts a brand new feature—Nothing. No RAM. The perfect amount of memory when your system has all the RAM it needs.

Now you can take advantage of the Quadboard's other enhancement capabilities without paying for unneeded memory or giving up that Quadram Quality. Whether you own a PC, PC II, or PC XT.

Quadboard comes with a parallel port designed to operate most parallel printers and other parallel devices. A fully-programmable serial port for all your data communications needs, and a battery-powered chronograph (a real-time clock/calendar to keep your system's clock always up-to-date).

Plus there's QuadMaster Software, too. With QuadRAM Drive. The program that lets you use part of system memory as multiple RAM drives. Solid-state drives that let you store and retrieve important information fast.

And Qspool. The buffer program that lets you compute while you print. Now you won't ever have to wait on your printer again. And there's also Qswap. The program that lets you change line printers 1 and 2 back and forth. As often as you like. Whenever your printing needs change.

And remember, Quadboard still comes fully-socketed. For memory expansion in 64K increments. So whenever you're ready, simply plug in the desired number of chips for up to 256K additional RAM.

Versatility. Dependability. Quality. Quadboard by Quadram. Still the first and only board your IBM PC, PC II, or PC XT may ever need.

\$295 (Socketed with no RAM installed)
Available at retail computer stores worldwide.



4355 International Blvd./Norcross, Ga. 30093
(404) 923-6666/TWX 810-766-4915 (QUADRAM NCRS)

Circle 385 on inquiry card.
© Copyright 1983 Quadram Corporation
All rights reserved

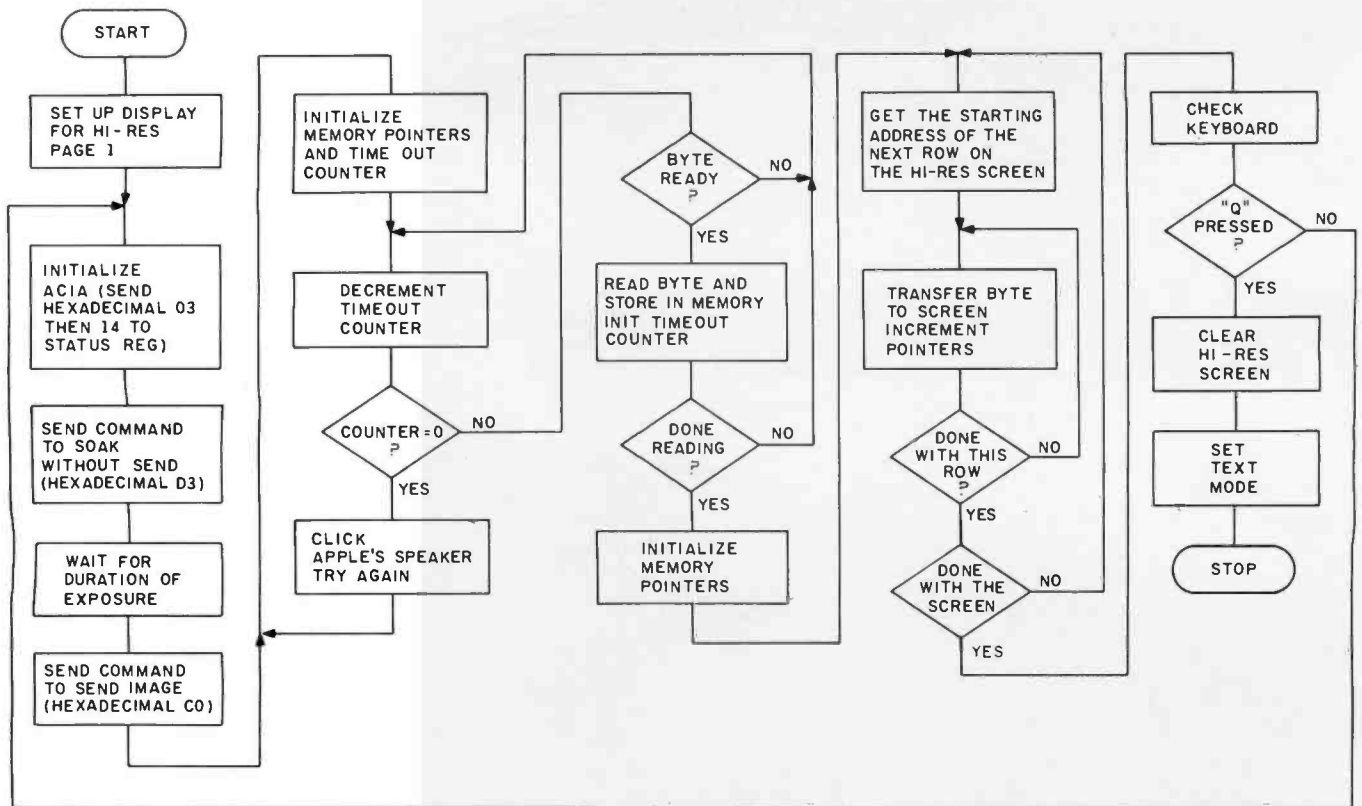

Figure 4: A flowchart of the Micro D-Cam demonstration program for the Apple II. The program consists of a BASIC main routine, shown in listing 1a, and some 6502 machine-language subroutines, shown in assembly-language form in listing 1b.

while waiting for the camera, it clicks the speaker, checks for a keypress, and tries the entire command sequence again. In this manner, you are alerted to any possible problems.

Because the Apple's hi-res screen display is mapped nonlinearly into memory space, a lengthy table at the end of the machine-language code provides the starting address for each consecutive row of the hi-res screen. The program gets the address of the beginning of each row and then reads 40 bytes from the camera, placing them consecutively on the

screen. The next row, and each row after it, is done in a similar manner.

Once the image is on the screen, a command is sent to the camera to refresh without sending. This gets it ready for the next exposure. Finally, the machine code checks the keyboard and processes any command inputs before returning to BASIC.

Obtaining Gray Scale

A more user-friendly demonstration of the Micro D-Cam that also provides a level of gray-scale capability is the GREY16 program of listing

2 (pages 518 through 538). It has one mode that allows you to do quick aiming and focusing of the camera, another to let you get an idea of what the final picture will look like, and a third to create a 15-intensity-level gray-scale picture on the Apple II. (The processes involved are outlined in the flowchart of figure 5. Unfortunately, space constraints prevent me from showing you a similar program for the IBM PC.)

Using GREY16, you can change the length of exposure for the image being displayed, or you can change the upper and lower exposure limits of the gray-scale image. Once you've obtained a satisfactory picture, you can save it on disk for later use or print it on an Epson MX-80 printer (equipped with Grafrax) using the screen-dump program. A summary of available commands in the GREY16 program is shown in table 4.

When it is first powered up, you start the camera running by selecting one of the options from the GREY16 menu. If the exposure time is insufficient, the screen will be black. If the exposure time is excessive, the screen

Command Character	Control Effect
N	display the image in normal size (256 by 64)
F	display the image in full size (256 by 128)
G	create a picture (256 by 128) with 15 levels of gray (this process takes about 30 seconds and displays a countdown of the number of exposures from F to 0)
E	change the exposure time of the current displayed image, the upper limit of the gray-scale image, or the lower limit of the gray-scale image
S	save to disk the picture currently being displayed (this may be done in any of the three display modes: normal, full, or gray)
Q	quit the program and return to BASIC

Table 4: A summary of user commands implemented in the GREY16 program of listing 2.

HOW DOES 1 = 50?

With **SUPER STAR**... The First S-100 Computer
To Use a 5 MB Removable Cartridge.

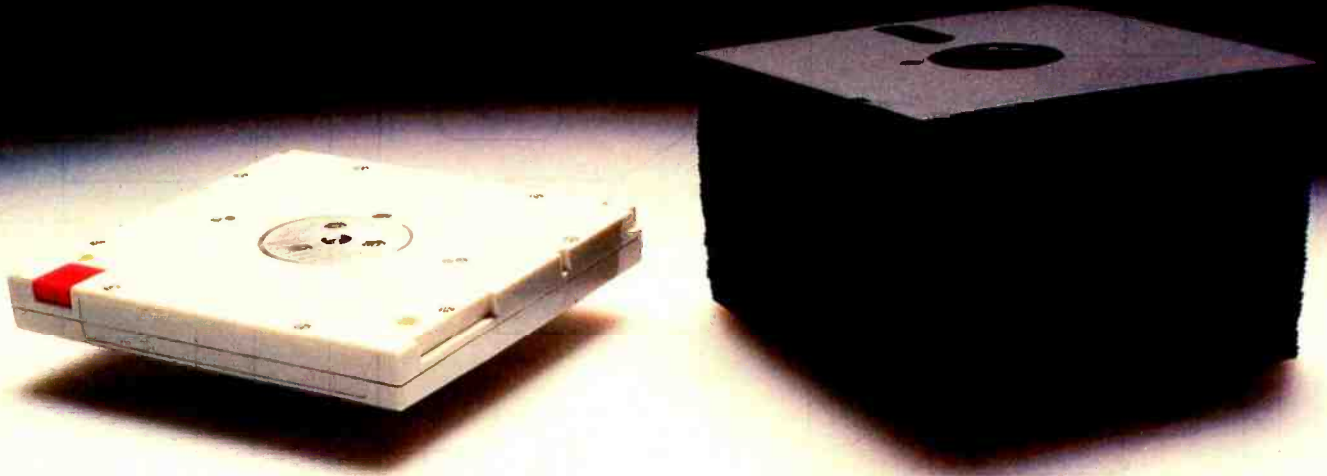

Advanced Digital's new **SUPER STAR™** is the first of a family of S-100-based computer systems to be equipped with a 5-1/4" 5-MB Fixed/5-MB Removable Cartridge Winchester disk drive (10 MB on-line storage capacity) as standard. Now you can have the capacity of up to 50 floppy diskettes and the speed and convenience of 100% backup using the industry-standard Dysan 5-MB cartridge.

SUPER STAR is the ideal system for business, professional, and educational applications. Its CP/M* operating system (standard) gives you access to a vast library of readily available software programs. The six-slot motherboard allows plenty of room for expansion.

And as your business grows, **SUPER STAR** can grow with you. If you need more memory, just plug it in. **SUPER STAR** is based on the S-100 IEEE standard. To add more users, simply add Advanced Digital's **SUPER SLAVE™** processor boards



and TurboDOS* operating system. Now you've got an extremely powerful, multi-user, multi-tasking, multi-processing **SUPER STAR** computer system for up to four users.

SUPER STAR is truly a Super computer system. Look at these outstanding features:

- New Slim-Line Profile
- 5-1/4", 10-MB Winchester Disk Drive, 5-MB Fixed, 5-MB Removable Cartridge
- 5-1/4", Half-High, 48TPI Floppy Disk Drive (Osborne Format Compatible)
- Six Slot Motherboard

- Switch-selectable 110/220V Power
- Up to 4 Users With **SUPER SLAVES** And TurboDOS
- CP/M Operating System Standard
- One Year Warranty

SUPER STAR is the perfect system for applications requiring large data storage capacity, speed, performance, reliability, and dependable, convenient back-up capability. And at a suggested retail price of \$5,000, **SUPER STAR** is a **SUPER VALUE**.

See the entire *Advanced Digital* product line, including the new **SUPER STAR**, at your local, quality computer dealer or contact:



5432 Production Dr.,
Huntington Beach, CA 92649
Phone: (714) 891-4004
Telex: 4722065 ITTSCSMA

*CP/M is a trademark of Digital Research Corp.
TurboDOS is a trademark of Software 2000 Inc.

SUPER STAR, SUPER SIX, SUPER SLAVE are
trademarks of Advanced Digital Corp.

For European Distributor, contact: (714) 891-4004

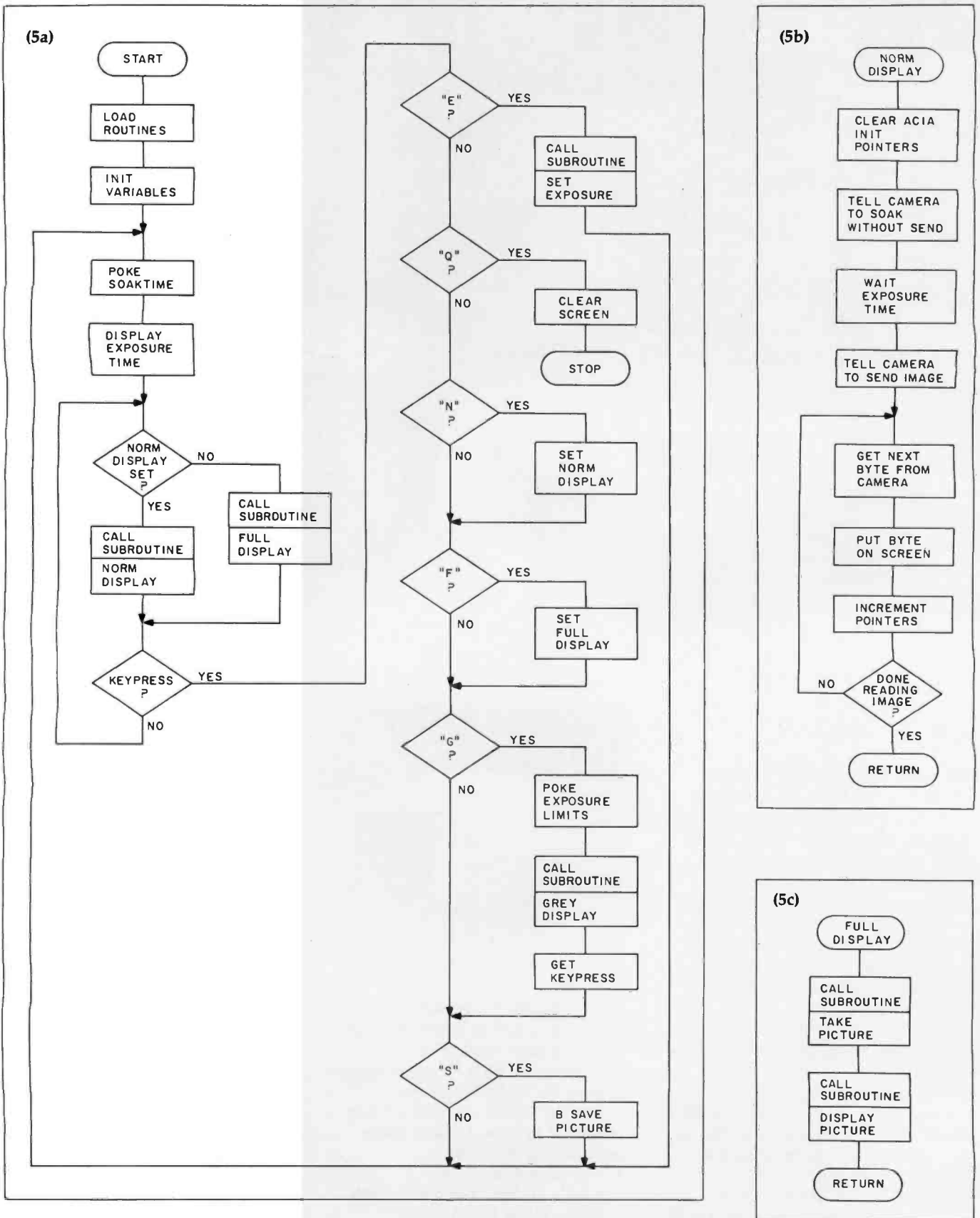

Figure 5: Flowcharts of the GREY16 program for the Apple II (the figure continues on pages 80 and 82). The BASIC portion appears as listing 2a, the machine-language portion as listing 2b. The main routine (5a) calls various subroutines: NORM DISPLAY (5b), FULL DISPLAY (5c), SET EXPOSURE (5d), GREY DISPLAY (5e), TAKE PICTURE (5f), DISPLAY PIC (5g), and ENHANCE (5h).

The subroutine GREY DISPLAY takes sensor pixels from 15 exposures and translates them into arrays of the smaller display pixels to represent intermediate brightnesses.

Figure continued on page 80

From Computer Plus to YOU ...

PLUS after PLUS after PLUS



Model 100 8K \$679
Model 100 24K \$835



Color Computer II 16K \$185
w/16K Ext. Basic \$245
w/64K Ext. Basic \$305

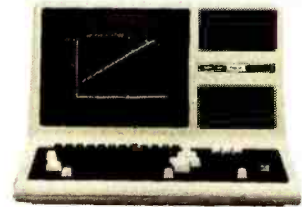

Model IV 16K \$849
Model IV 64K
2 Disk & RS232 \$1699



CITOH Prowriter \$375
CITOH Prowriter II \$649



CoCo Drive 0 \$329
CoCo Drive 1 \$235



DWP210 \$629

BUY DIRECT Here are just a few of our fine offers ...
call TOLL FREE for full information.

COMPUTERS

Model 12 64K 1 Drive	\$2699
Model 12 64K 2 Drive	3375
Model IV 16K	849
Model IV 64K	
2 Disk & RS232	1699
Color Computer II 16K	185
w/16K ext. basic	245
w/64K ext. basic	305
Pocket Computer 2	165
Model 16B 1Dr 256K	4249
Model 16B 2Dr 256K	4915
Model 100 8K	679
Model 100 24K	835

MODEMS

Lynx MII/MIII	235
Hayes Smartmodem II	235
Hayes Smartmodem 1200	565
Novation Smartcat 1200	459
Novation J-Cat	125
R.S. AC-3	129
R.S. Modem I	89

R.S. Modem II

R.S. DC-1200 565

PRINTERS

Smith Corona TPI D.W.	469
Silver Reed EXP500 D.W.	430
Silver Reed EXP550 D.W.	665
Daisy Wheel II	1745
DWP210	629
DWP410	1159
CGP115	159
DMP100	315
DMP120	395
DMP200	520
DMP400	1010
DMP500	1219
DMP2100	1745
Gemini 10X	315
Gemini 15	425
CITOH Prowriter	375
CITOH Prowriter II	649
Okidata	CALL
Epson	CALL

DISK DRIVES

R.S. Model IV Drive 0	515
Color Computer Drive 0	329
Color Computer Drive 1	235
Primary Hard Disk M12	2689
Primary Hard Disk MIII	1799

ETC.

CCR-81 recorder	52
C.C. Joysticks (pair)	22
16K Ram Chips	25
64K Ram Chips	75
8K Par/Par Microfaser	135

Parallel printer cables are available for most computers.

SOFTWARE

CoCo FHL Flex D.O.S.	69.95
R.S. Software 10% off list.	
Send for listing of brand name software.	

We have the lowest possible Fully Warranted Prices AND a full complement of Radio Shack Software.

Prices subject to change without notice. Not responsible for typographical errors. TRS-80 is a registered trademark of Tandy Corp.



TOLL FREE
1-800-343-8124

computer plus

P.O. Box 1094
480 King Street
Littleton, MA 01460
617-486-3193

Write for your free catalog

SINCE 1973 —

Figure 5 continued:

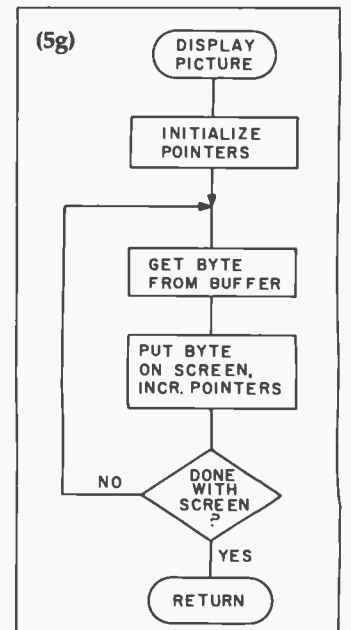
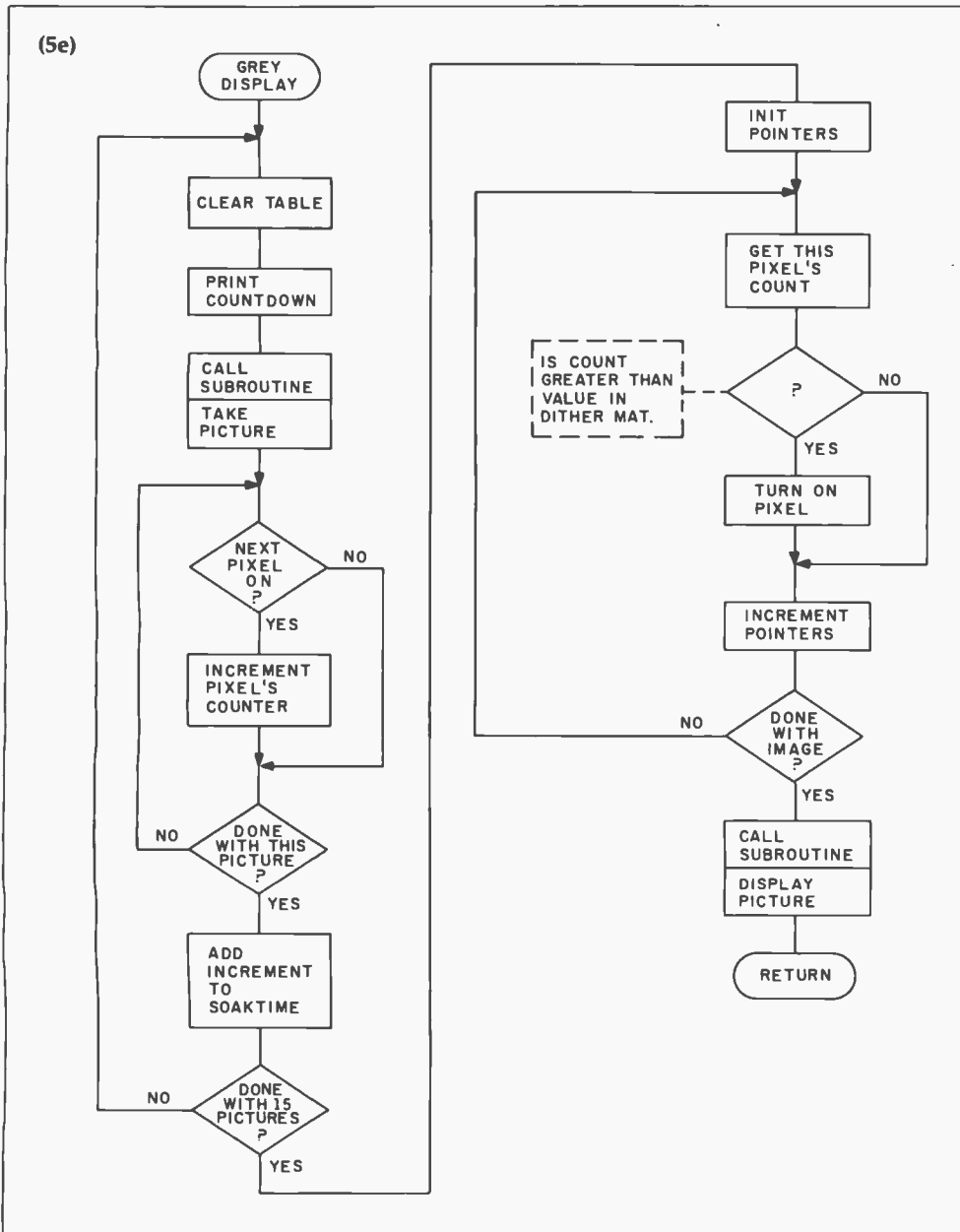
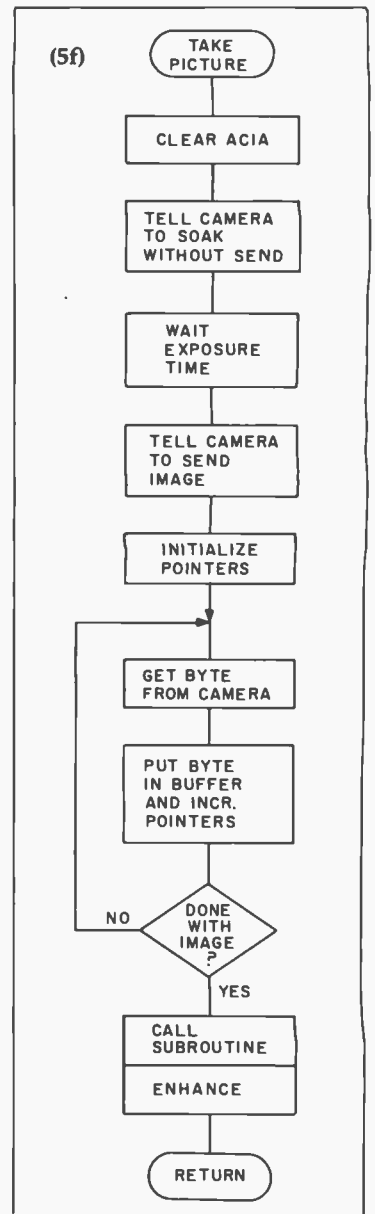
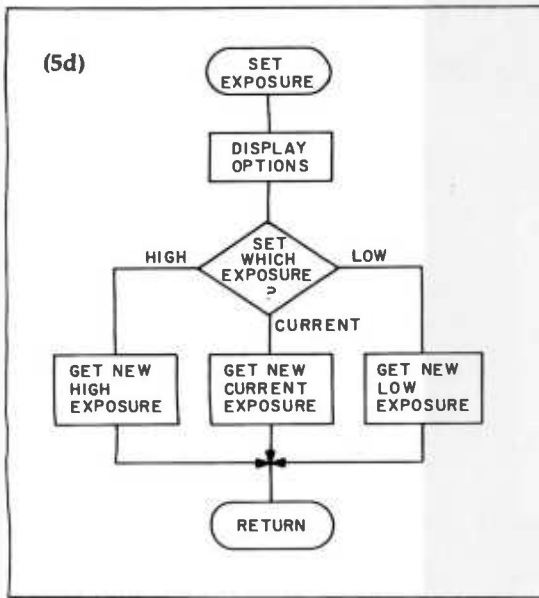

\$299

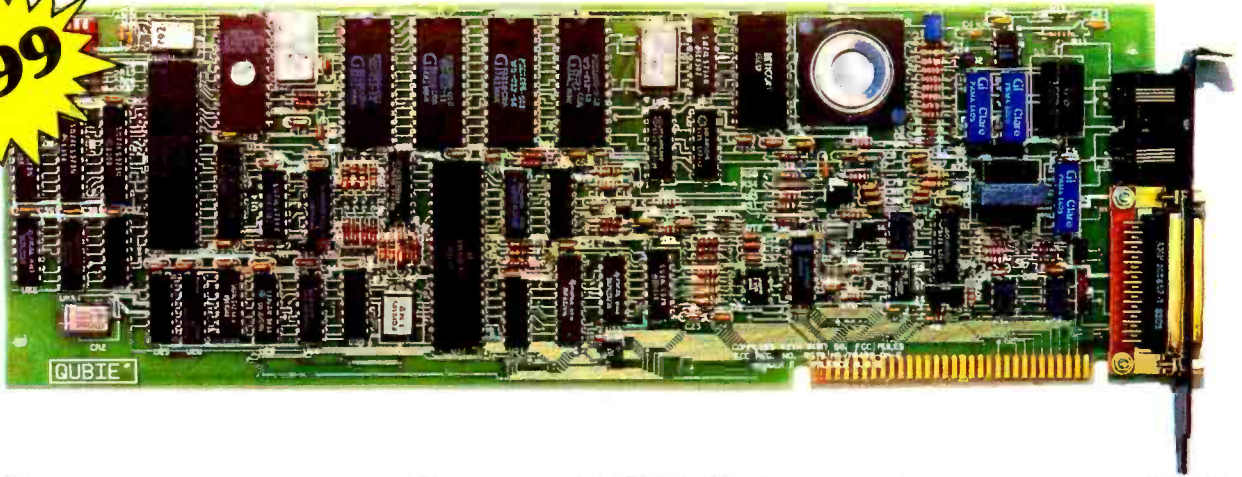

Why pay more for a 1200 baud, auto-dial, 212A Modem for your IBM PC?

Flip the pages. You see PC modem cards with fewer features advertised for as much as \$599. Up until now that's how much it cost to make a modem capable of transmitting at 120 characters per second (1200 baud). It doesn't take a computer to figure out the savings in phone line charges when you communicate four times faster than the 30 character per second modems (300 baud). Now you can have the solution to your communication needs at an unheard of price.

NOW COME THE SMART GUYS

You can imagine how precise the components had to be to convert tones over a phone line into characters. Precision equates to cost. With the advent of the mass market in personal computers the economics of scale drove the costs of manufacture down but did not effect the precision required. The technology used is called "analog filtering". It is the process of sending (modulating) and receiving (demodulating) tones with perfect pitch. A lot of adjusting, noise suppression, and a little magic is required. Real expensive. Some use lots of chips and filters (known as discrete components). The latest rage is LSI (Large Scale Integration) technology. Which is the same old analog stuff condensed onto fewer chips.

A NEW IDEA

We took a different approach. With the Qubie' PC modem card you can say goodbye to the fellow who delivers your ice because refrigeration has been invented. Through the use of four microprocessors (see picture) the tones are chopped up digitally and measured millions of times per second, eliminating the need for analog circuitry. Two microprocessors do the modulating, two the demodulating. The chips are programmed to emulate the 103 (30 characters per second) or 212 (210 characters per second) standards and determine the correct speed automatically. It's a proven technology that provides outstanding performance. Best of all, it's inexpensive and reliable.

NO CORNERS CUT

We included every feature you would want in a modem card. It plugs into your IBM PC or XT and occupies any one slot since it is just 6/10 of an inch thick. The card comes with an asynchronous port which can be used for a printer when you are not using your modem (COM1 or COM2). It's FCC registered for direct connection to your modular phone jack with the cable which is included. There is a separate modular jack for

your telephone or you can listen through the boards' speaker. It operates in full or half duplex mode on Rotary dial lines (pulse dialing) or on tone lines (DTMF), or a combination of both. It will work in originate or auto-answer modes. A separate microprocessor, a Z8, controls all the functions.

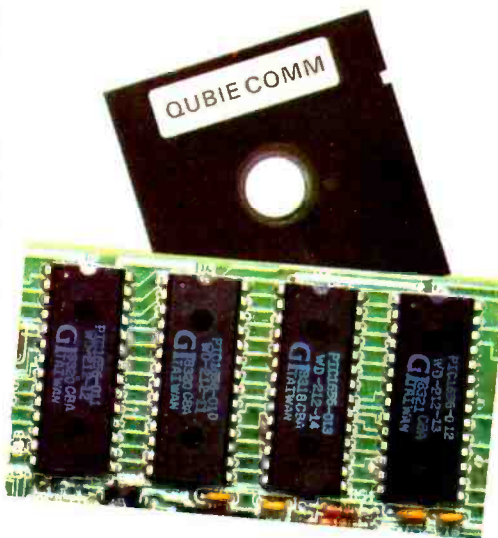

LET'S TALK SOFTWARE

The Qubie' PC modem is 100% compatible with the Hayes software commands so you can use any of the popular communications packages like CrossTalk, Transend, PC-Talk III, etc. Of course we include our Qubie'Comm software package. We think it is as comprehensive a program as you will need. It stores phone numbers, log-on information, handles setting the modems characteristics, saves to disk files, transmits from disk files, and even allows you to transmit a disk file with error checking using the XMODEM protocol. You can even set up your modem for auto answer mode so your computer can be accessed remotely.

WHY BUY FROM US

Because besides having the most advanced product on the market, we stand behind it and you. If at any time during the one year warranty period your modem should require service, we will fix or replace it within 48 hours. Notice also there are no hidden charges in our price. Nothing extra for credit cards or COD charges. We even pay UPS to deliver to you. If you still are

not convinced, and are ready to buy another brand of modem, ask them if their product can take our acid test.

THE ACID TEST

Qubie' gives you a 30 day satisfaction guarantee on your modem. If you are not completely satisfied we will refund the entire amount of your purchase including the postage to return it. If you can, get any of our competitors to give you the same guarantee. Buy any modem you like and return the one you don't like. We know which one you will keep.

WHY PAY MORE?

We don't have a clue. It's all here. A high quality, full featured, communications package at a price that used to be reserved for 300 baud modems. But if you decide to spend an extra \$200 or \$300, we would sure like to hear why. We have spent lots of time thinking about it, and frankly, we just can't come up with a reason.

TO ORDER BY MAIL SEND

- Your name and shipping address
- Daytime phone number
- California residents add 6% sales tax
- Company check or credit card number
With expiration date. (Personal checks take 15 days to clear)



TO ORDER BY PHONE:

Call (805) 482-9829

PRICE:

\$299 Includes: 212A compatible 300/1200 Baud Direct-Connect modem, Qubie'Comm Software, cable to connect to modular phone jack, installation instructions and manual. 1 year limited warranty.

Cable for Serial port to printer \$25

SHIPMENT

We pay UPS surface charges. UPS 2 day air service add \$5 extra. Credit card or bank check orders shipped next day.

Circle 389 on inquiry card.

QUBIE' DISTRIBUTING

4809 Calle Alto
Camarillo, CA 93010

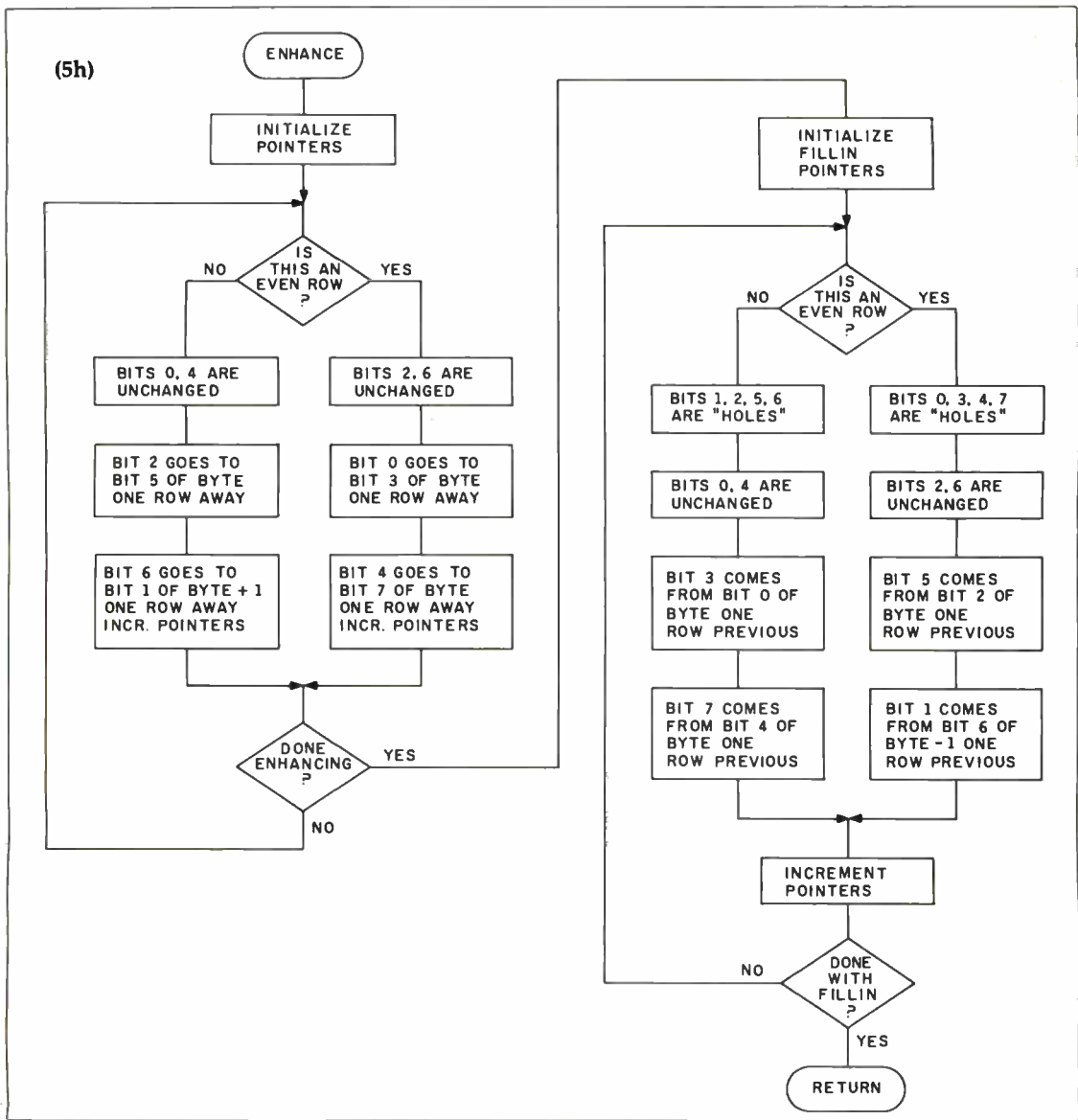

Text continued from page 76:

will be completely white. These situations may be remedied by increasing or decreasing the exposure time or changing the lens aperture. You may need to focus, also. Eventually, a clear picture will appear on the video screen when the lens is properly adjusted.

The gray-scale portion of the program demonstrates what can be done with just a little bit of software enhancement, permitting you to create images with 14 intermediate levels of brightness (plus extreme dark and bright) and display them on the Apple's hi-res screen. The image of an automobile shown in photo 1 is an example.

The technique used to display the gray-scale pictures on the Apple II Plus and IIe computers is known as

ordered dithering, in which half-tone values are constructed from multiple binary black or white images. The process requires the Micro D-Cam

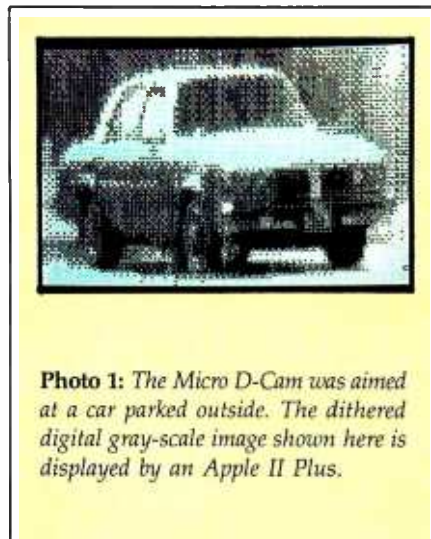

system to take 15 exposures of the same subject, each lasting a little longer than the previous one. (This normally takes only several seconds.) After each exposure is taken, every pixel in it is checked. If the pixel is on (showing a 1 value corresponding to brightness above that exposure's threshold), a counter location corresponding to that pixel is incremented. At the end of 15 passes, this process yields a table of values, each value describing the relative intensity of its corresponding pixel. For example, if a pixel's final value is 15, that pixel should be displayed maximally bright; if a pixel's value is 8, the pixel deserves a shade of gray half-way between the black and white extremes.

Once the pixel-intensity table has been constructed, a 4 by 4 dither

Hayes™

More micro software is written for Hayes than for any other modems!

Because Hayes, the telecomputing leader, continues to lead the way! With popular-selling modems that make telecomputing a breeze for beginners or professionals. And with sophisticated engineering that appeals to software developers.

Send for our free *Communications Software Directory*. It lists more than

a hundred software programs written for Hayes modems by independent programmers. For diverse communication functions, from the practical to the fun. But all maximizing the advanced telecomputing capabilities of Hayes modems.

Whether you're collaborating on competitive strategies with offices

in the field. Doing your gift shopping via computer. Or collecting and analyzing commodity or stock information. Let Hayes provide the superior communications link!

Mail the coupon today for your free copy of the Hayes Communications Directory. (Or pick one up at your local computer store.)

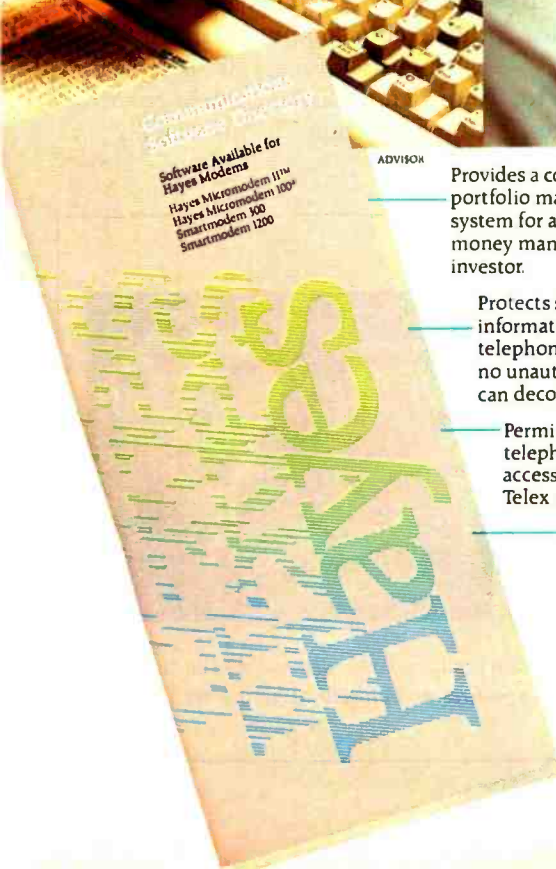

ADVISOR

Provides a comprehensive portfolio management system for active trader, money manager or investor.

Protects sensitive information sent over telephone lines so that no unauthorized person can decode files.

Permits use of normal telephone lines for accessing international Telex network.

THE FLIGHT PLANNER

Aviation software simplifies planning and increases safety.

Automatically logs-on to networks, answers phone, saves incoming data, and allows it to be stored on disk, edited, and printed.

Transfers files between various micros, minis or mainframes.

Automatically answers phone in your name; receives, delivers messages.

TELE GAMMON

Allows users to play backgammon with players at distant locations.

Mail To: Hayes Microcomputer Products, Inc.
Attention: Marketing Services, 5923 Peachtree Industrial Blvd., Norcross, Georgia 30092.

Name _____

Address _____

City _____ State _____ Zip _____

Please send additional information on:

- Smartmodem 300* **
- Smartmodem 1200* **
- Smartmodem 1200B* (plug-in board for IBM PC)
- Micromodem IIe* (for Apple computers)

Hayes BY2

* FCC approved in U.S.A.
** DOC approved in Canada.
©1983 Hayes Microcomputer Products, Inc.

NOTE: More and more software is being written for Hayes modems everyday. Please let us know if you would like to have your program included in our next software directory.

Circle 205 on inquiry card.

Steven A. Ciarcia
Consulting Editor

BYTE
A McGraw-Hill Publication
70 Main Street
Peterborough, New Hampshire 03458
Telephone 603/924-9281



(2a)

(2b)

Photo 2: A corner of the author's business card (2a) was easily reproduced by the Micro D-Cam (2b) because the printing represents only two levels of brightness. One potential use of the image camera is in optical character recognition.



matrix is used to assign a display value (an array of binary pixels) to each screen position. In this software, the matrix is as follows:

0	8	2	10
12	4	14	6
3	11	1	9
15	7	13	5

Then, one pixel at a time, the values in the table of final image magnitudes are compared to the array-element values in the matrix. If the image value for the pixel is

greater than the element's value, that array element is turned on. If the intensity value is 0, none of the matrix elements are displayed bright; if the value is 8, elements 0 through 8 are displayed bright; and if the value is 15, all the elements become bright. In this manner, 15 levels of luminance may be represented but at a certain loss of spatial definition. The process is repeated across the entire screen until each screen position has a value assigned to it.

It would definitely be possible to use different-size dithering matrices,

with certain trade-offs. For example, a 2 by 2 matrix would yield only 5 levels of gray but would have much finer spatial definition, while an 8 by 8 matrix would yield 64 levels of gray but with much loss of spacial definition.

The GREY16 program overcomes many of the limitations associated with binary optical sensors. While black print on white paper (like my business card, shown in photo 2) is easily viewed by the Micro D-Cam with no enhancement, we don't live in a pure-black-and-white world, and three-dimensional objects need shading to be recognized on a two-dimensional video display.

This is most easily demonstrated with a series of photos of a pair of dice. Photo 3a shows the color and lighting conditions of our sample object. If we use the Micro D-Cam without gray scale, we obtain the binary picture in photo 3b. (This slightly vague yet quite representative picture of the dice would probably be usable in robotics or some recognition applications.)

For a more representative picture, we can invoke the G command in the GREY16 program to produce photo 3c. There is now no question of what the subject is or what value is shown on the dice. If the image were reproduced on a computer capable of displaying half-tones, it would look much more like photo 3a than this dithered Apple II Plus display.

(3a)



(3b)

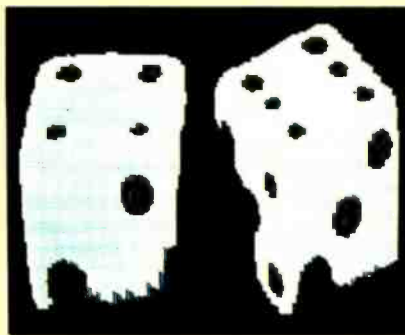

(3c)

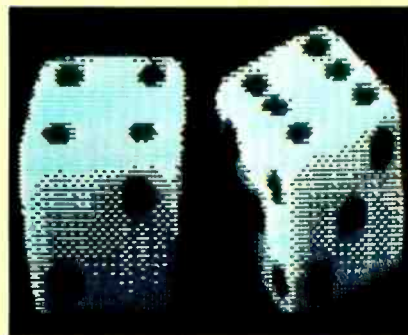

Photo 3: A pair of dice (3a) was scanned by the Micro D-Cam. When only two levels of luminance are recorded and sent to the computer's display, the result is the output shown in photo 3b. When multiple gray-scale exposures and ordered dithering are invoked, the more easily recognizable output of photo 3c appears.

Pick up a little of the best.

Pick up the MICRO MATE Computer Paper you need! Quality Paper... packaged in a make-sense, easy to handle quantity... at an affordable price!

MICRO MATE continuous computer papers fit printers of all popular word processors, desktop, personal and small business computers.

Available from independent forms distributors, computer manufacturers, computer supplies catalogues, office supply and computer stores and other retail outlets in your area.



MICRO MATE™ COMPUTER PAPER

Computer Paper that is affordable and portable!

M-91 series fit 80 column printers.

M-41 series fit 132 column wide printers.



M910LE20
9 1/2" x 11"
blank register bond 1 part,
1/2" perforated side
margins (ideal for word
processors)



M910PPTC
9 1/2" x 11"
blank, 1/2" perforated side
margins, carbonless 2
part



M910PPTC
9 1/2" x 11"
blank, 1/2" perforated side
margins, carbonless 4
part



M41GHS
14 7/8" x 11"
1/2" green bar register
bond 1 part



M41GTC
14 7/8" x 11"
1/2" green bar carbonless
2 part



M41GTC
14 7/8" x 11"
1/2" green bar carbonless
4 part

ERG/68000 MINI-SYSTEMS

- Full IEEE 896/S100 compatibility

HARDWARE OPTIONS

- 8MHz, 10MHz or 12MHz 68000 CPU
- Memory Management
- Multiple Port Intelligent I/O
- 64K or 128K STATIC RAM (70 nsec)
- 256K/512K or 1MB Dynamic RAM, with full parity (150 nsec)
- 5¼" - 8" D/D, D/S floppy disk drives
- 5MB-40MB hard disk drives
- Full DMA Disk Interface
- SMD Disk Interface
- ¼" tape streamer
- 10 to 20 slot backplane
- 20 or 30A amp power supply
- Desk top or Rack mount cabinets

SOFTWARE OPTIONS

- 68KFOR¹ systems language with MACRO assembler and META compiler, Multi-user, Multi-Tasking
- Fast Floating Point package
- Motorola's MACSBUG
- IDRIS⁵ Operating System with C, PASCAL, FORTRAN 77, 68K-BASIC¹, CIS COBOL⁴, RDBMS
- UNIX² Sys III C, etc.
- CP/M-68K³ O/S with C, Assembler, 68K-BASIC¹, 68KFOR¹, Z80 EMULATOR¹, APL
- VED68K¹ Screen Editor

Trademark ¹ERG, Inc.

²BELL LABS ³Digital Research
⁴Micro Focus ⁵Whitesmiths

30 day delivery
with valid Purchase Order
OEM prices available
For CPU, Integrated Card Sets
or Systems.



Empirical Research Group, Inc.
P.O. Box 1176
Milton, WA 98354
206-631-4855

Closing Observations

Two articles have not been enough to describe all the capabilities of the Micro D-Cam. If I had more time, I'd try some experiments using different lenses and filters. Theoretically, if three exposures were taken through red, green, and blue filters, we should be able to create a color image.

One interesting fact I did observe is that the IS32, like most silicon-based image sensors, is infrared-sensitive. My test was somewhat unscientific, and I have no precise data on the Optic RAM's spectral sensitivity. I merely lighted the subject with some infrared light-emitting diodes, but it was clearly seen by the Micro D-Cam even in visible-light darkness.

This mild success leads me to consider related experiments. Don't count on it, but in a few months you just might be reading about some sort of character-recognition wand I've built using an Optic RAM. In the meantime, if you find any other dynamic RAM chips that are suitable in this application or wish to show me a character-recognition program of your own, please write and let me know.

Next Month:

Communicating with their fellow humans can be a problem for people who cannot speak. We'll look at a way digital electronics can be harnessed to remedy this difficulty. ■

Editor's Note: For a review of a similar assembled product, see page 316.

References

1. Ciarcia, Steve. "Analog Interfacing in the Real World." BYTE, January 1982, page 72.
2. Ciarcia, Steve. "Build the Micro D-Cam Solid-State Video Camera, Part 1: The IS32 Optic RAM and the Micro D-Cam Hardware." BYTE, September 1983, page 20.
3. Crow, Franklin C. "Three-Dimensional Computer Graphics." Part 1, BYTE, March 1981, page 54; Part 2, April 1981, page 290.
4. Grob, Bernard. *Basic Television: Principles and Servicing*, 4th ed. New York: McGraw-Hill, 1975.
5. Newman, William M. and Robert F. Sproull. *Principles of Interactive Computer Graphics*, 2nd ed. New York: McGraw-Hill, 1979.
6. Tomas, Joe. "Hardware Review: Dithertizer II." BYTE, February 1982, page 219.

7. Walker, Terry, Harry Garland, and Roger Melen. "Build Cyclops: First All Solid-State TV Camera for Experimenters." *Popular Electronics*, February 1975, page 27.
8. Williams, Thomas. "Digital Storage of Images." BYTE, November 1980, page 220.

The following items are available from

The Micromint Inc.
561 Willow Ave.
Cedarhurst, NY 11596

(800) 645-3479 for orders
(516) 374-6793 for information

1. Complete Micro D-Cam unit including interface card, extension cable, IS32 Optic RAM, lens, remote housing, operator's manual, and utility software. Specify Apple II (II Plus or IIe) or IBM Personal Computer.
Assembled and tested.....\$295
2. Same as item 1 except in kit form. Specify Apple II or IBM PC.
Complete kit.....\$260
3. IC32 Optic RAM sold separately.
Each.....\$42
4. Serial-interface (RS-232C) Micro D-Cam for general use. Software listings for several different computers to be available soon.
Call for price and delivery.

Please add \$4 shipping and insurance in continental United States, \$20 overseas. New York residents, please include 7 percent sales tax.

Editor's Note: Steve often refers to previous Circuit Cellar articles as reference material for each month's current article. Many of these past articles are available in reprint books from BYTE Books, McGraw-Hill Book Company, POB 400, Hightstown, NJ 08250.

Ciarcia's Circuit Cellar, Volume I covers articles that appeared in BYTE from September 1977 through November 1978. Ciarcia's Circuit Cellar, Volume II contains articles from December 1978 through June 1980. Ciarcia's Circuit Cellar, Volume III contains articles from July 1980 through December 1981.

Special thanks to Carl Baker and Jim Herrud of Micron Technology Inc. for their contributions to this project.

To receive a complete list of Ciarcia's Circuit Cellar project kits available, circle 100 on the reader service inquiry card at the back of the magazine.

Steve Ciarcia (POB 582, Glastonbury, CT 06033) is an electronics engineer and computer consultant with experience in process control, digital design, nuclear instrumentation, product development, and marketing. In addition to writing for BYTE, he has published several books.

The Faster The Computer, The Faster The Floppy.

Floppies Think They're Winchester.

People get awfully impatient with slow drives. But the awful truth is, most micros are slower than the slowest drives.

When a processor is unable to keep up with a drive, it simply slams the door shut after reading only part of a track. The diskette continues speeding along under the head, but no data is being transferred. After a sector of dead time, the read resumes again where it left off.

Not so in a Sage™ micro.

It can read an entire track in one revolution, step to the next cylinder and read another entire track during the second revolution. Time-wasting with interleaving and skewing never occur.

The lightning fast disk interfacing and 68000 processor actually let the floppy drives on a Sage micro meet the theoretical transfer rate for standard 5¼ inch floppy disk drives.

How fast is that? Fast enough to load a 20K program in about a second.

Our Winchester's Think Big.

There is only so much area on a 5¼ inch hard disk. So how come we can give you an extra 1.5Mybytes on a 10Mybyte Winchester?

Remember, it's the computer, not the drive, that makes the difference.

The Sage IV micro features full track buffering instead of one or two sector buffering. This means that the disk area that usually must be reserved for

header information, synchronizing gaps and trailer gaps can now be used for storage.

Be A Sage Thinker.

No other computer gives you so much disk performance and capacity for so little.

So whether you'd be satisfied with one or two floppies that think they're Winchester's, or if you need big Win-

chester capacity up to 200 megabytes, think Sage micros.

Call today for full details and the name of your nearest dealer.

Sage Computer Technology, Corporate Office, 4905 Energy Way, Reno, Nevada 89502. Phone (702) 322-6868. TWX: 910-395-6073/SAGE RNO

Eastern United States

Sage Computer Technology, 15 New England Executive Park Suite 120, Burlington, MA 01803 (617) 229-6868

In UK

TDI LTD, 29 Alma Vale Road, Clifton, Bristol BS8-2HL
Tel: (0272) 742796
Tx: 444 653 Advice G

In Germany

MM Computer, GmbH, Hallwanger Str. 59, 8210 Prien
Tel: 08051/3074 Tx: 525 400 mmco-d

© 1983 Sage Computer Technology all rights reserved Sage & Sage IV are trademarks of Sage Computer Technology

SAGE™
COMPUTER TECHNOLOGY

The computer you don't wait for!

Circle 409 on Inquiry card.



A ONE-STOP SOURCE



- Disc Drivers
- Printers
- Switching Power Supply
- Monitors
- Personal Computers

SUPERCOM®

SUPERTRON ELECTRIC CO., LTD.
 P.O. Box 55-1326, Taipei, Taiwan, R.O.C.
 Telex: 24317 SUPEROHM Tel: (02) 713-3492

SPECIALIZING IN DISK DRIVER

Specifications:

- *Capacity: 163K Bytes.
- *48TPI stepping mechanism, 40 tracks to be used for recording.
- *Average rotational latency: 100 milliseconds.
- *Track to track access time: 20 milliseconds.
- *Data transportation speed: 250K bits/sec.
- *Mean time between failure, over 8,000 hours.
- *Disk rotation speed: 300 RPM.
- *Dimensions: 150(W)x51(H)x233(L).
- *Net weight: Less than 1.9kg.



FIDELITY DEVELOPMENT CORP., LTD.
 P.O. Box 1625 Taipei, Taiwan, R.O.C.
 Telex: 21776 FIDCO

APPLE * EXPANSION CARDS

16K RAM	\$ 41.00
128K RAM	\$315.00
80 Column Card	\$130.00
Z-80 Card	\$115.00
RS-232 Card	\$ 75.00
RS-232C Card	\$ 82.00
IEEE-488 Card	\$149.00
Disk Control Card	\$ 68.00
Parallel Interface Card	\$ 61.00
Graphic Card 16K	\$ 99.00
Grappler Card+ 16K Buffer	\$129.00
Grappler+Printer Interface Card	\$ 99.00
Super Serial Card	\$129.00
Super Copy Card-64K	\$101.00
Clock Card	\$ 85.00
Music Synthesizer Card	\$175.00
W/2 external Speakers	
6809 Card	\$315.00
Forth-79 Card	\$ 75.00
A-D/D-A Card	\$199.00
A/D Conversion Card	\$ 99.00
-16 channels	
D/A Card -4 channels	\$123.00
6522 VIA Card	\$ 75.00
Communications Card	\$ 98.00



SYSTEM SPECIALS

64K-Apple* Compatible. Disk Driver.
 Disk Control and 80 Column Card.
 12" Green Monitor

~ \$999 ~

64K-Apple* Compatible, Expandable to 192K
 32K Rom, Advanced 78 Function Keyboard,
 W/Disk Driver, Controller and 80 Column Card,
 12" Green Monitor

~ \$1180 ~

**10% Discount on Orders
 Paid Before Oct 31/83**

ACCESSORIES

KEYBOARD

- (1)Apple* Compatible \$ 83.00
- (2)W/26 User Definable Keys \$147.00

POWER SUPPLY

- Heavy Duty Switching Power Supply \$ 86.00
- +5V 5A +12V 2 A
- 5V 0.5A -12V 0.5 A
- Fan W/Surge Control \$ 42.00
- Powerstrip W/S Control \$ 23.00

JOYSTICK

- (1)Deluxe Model \$ 39.00
- (2)Basic Model \$ 14.00

DISK DRIVER

- Shugart SA-390 \$230.00

MODEM

- All Modem-300 Baud
- Acoustic Modem \$173.00
- Auto Answer \$169.00
- Auto Answer-6 Slot \$360.00
- Auto Answer12 Slot \$473.00
- Additional Slots \$100.00

TELEPHONE

- W/10 No. Memory \$ 35.00
- Cordless \$ 85.00

**Discounts on Volume Purchases
 Further Items Available
 on Request**

Terms: All prices subject to change without notice and availability. Cashier's check/MO/Bank transfer: allow time for company or personal checks to clear. VISA/MASTER CARD/COD +3% CA Res. Residents ADD Tax.
 SHIPPING: \$2 plus 2% for UPS surface \$4 plus 2% for Blue Label. Overages will be returned.
 *APPLE IS THE REGISTERED TRADEMARK OF APPLE COMPUTER, INC.

CIRCUITS & SYSTEMS CORP.
 2210 Wishire, Blvd., Suite 577
 Santa Monica, CA90403, USA.
 (213) 933-7183

Champagne performance.

\$999*

FOR THE MULTITECH BUSINESS PACKAGE

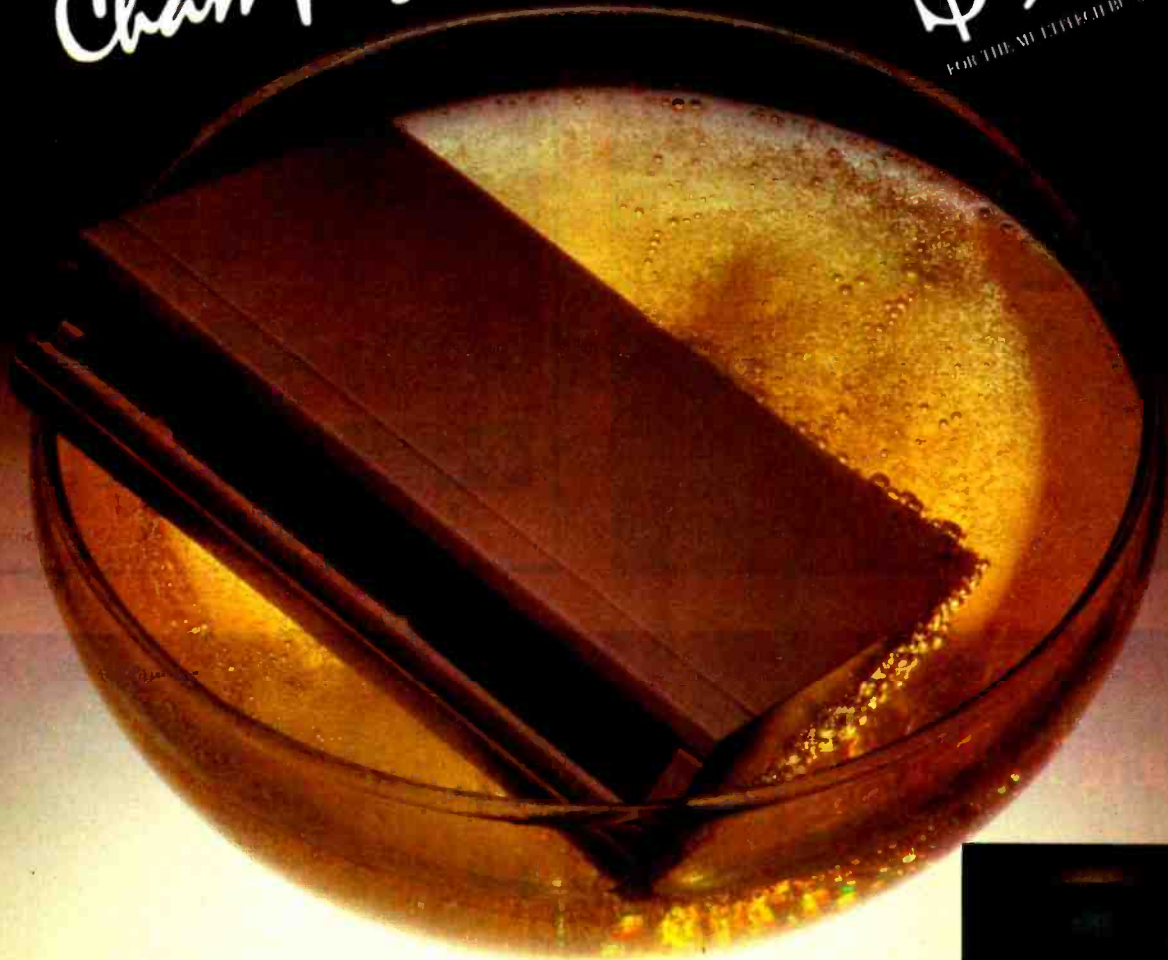

For businesses on a beer budget.

For a small business system that's beer-budget priced there's no better buy today than the MIC-500 from Multitech.

It's got the same sparkling performance features as other popular micros including Z-80A processor, 64K RAM, CP/M 2.2 operating system, and a full compliment of business software including a word processing package, an electronic spreadsheet, a sorting utility, a mass mailing system and a data base system. This package is especially designed for the MIC-500 by the Structured Systems Group, one of the top software houses in the U.S.

Beyond that the MIC-500 is definitely not ordinaire. Dual floppy disk drives packing 500K bytes of low profile storage give you the on-line power you need. For larger storage requirements, the MIC-500 also comes with 2 megabytes of storage for only a moderately higher price. Unlike comparably priced micros, the MIC-500 also features wide expandability via two RS-232C ports and a parallel printer port.

The corker though is price: the MIC-500 comes with the pricetag of an unbelievable \$1195, inclusive of the powerful business software package.

Of course, dealers and OEMs can expect discounts when you buy them by the case. For full details on the powerful MIC-500, write Multitech Electronics, 195 El Camino Real, Sunnyvale, CA 94087. Or phone (800) 538-1542; In California (408) 773-8400.

Circle 320 on inquiry card.



MULTITECH ELECTRONICS

195, W. El Camino Real,
Sunnyvale, CA. 94087, U.S.A.
TEL: (800) 538-1542,
In California (408) 773-8400

Outside North America please
contact:

Multitech Industrial Corp.
315, Fu Hsing N. Road,
Taipei 104, Taiwan, R.O.C.
TEL: (02) 713-4022 (20 lines)
TLX: 23756 MULTIC
19162 MULTIIC

ANKO JOYSTICKS, What A Joy!

ONE YEAR WARRANTY

Accurate and stable performance, elegant appearance and durable mechanism, easy operation on a desk or in hand, and long life variable resistor control are some of the laudable qualities of our unique products.



Please feel free to contact us at:

ANKO ELECTRONIC CO., LTD.
No. 180 Fuho Rd., Yungho City, Taipei County, Taiwan, R.O.C.
Cable: "ANKOELECO" Taipei Telex: 31375 ANKO
Tel: (02) 924-6397, 924-5443
In Western North America, Contact the exclusive dealer:
PRIDE COMPUTER PRODUCTS, INC.
319E. 2nd Ave, Vancouver B.C. V5T 1B9, Canada
Tel: (604) 879-1579 Telex: 0454247

You need . . .

DATATREE ET-2000 SMART TERMINAL

not only because it has 9 additional functions as

FUNCTION	ET-2000	TELEVIDEO 950
CLEAR LINELOOK	ESC13	—
SET PAGE MODE RECEIVE	ESC A	—
CLEAR USER LINE	ESCfDEL	—
SEND FIELD	ESCm	—
REVERSE FIELD TAB	ESCn	—
CONTINUOUS BELL ON	ESC01	—
CONTINUOUS BELL OFF	ESC02	—
READ CURSOR CHARACTER	ESCp	—
CLEAR PAGE MODE RECEIVE	ESC-	—

. . . but also it provide more excellent features that will make you leader in terminal market. Unit in P.C. model also available. Contact us today for more informations.



OEM terms available on request



DATATREE

G. G. M. INDUSTRIAL CO., LTD.

P.O. Box 53-692, Taipei, Taiwan, R.O.C.
Telex: 27014 GGMCO Cable: "GGMCO" Taipei
Tel: (02) 700-2515/6, 703-2171 (10 Lines)

The Vanguard Of Things To Come...



Video Controllers *For home video entertainment systems *Digital logic circuit push-button controls *5 RF Input signals and impulse signal switching to any of 3 devices allows different combinations of input/output *Contains a small internal amplifier which strengthens weak signals and minimizes TV picture noise *Operates from 120V AC 60 Hz line *Sizes: 190 (L)x260 (W)x62 (H)mm

Disk Drives

- * Low Profile, Light Weight
- * High-precision head positioning mechanism
- LDD-103SSA Apple II Compatible
- LDD-103SDS IBM Compatible

- * Eject mechanism for easy removal of discs
- * Less heat, generation and minimum noise.
- * Direct drive
- * Track to track 6 msec.

Mechanical Dimensions.

Height: 41.3mm (1.62in.)
Width: 146.1 mm (5.75in.)
Depth: 215 mm (8.46 in.)
Weight: 1.4 Kg (3.08LBs) Nominal



CAPACITY	LDD-103SSA SINGLE DENSITY	LDD-103SDS DOUBLE DENSITY
Unformatted:		
Per Disk	125 Kbytes	250 Kbytes
Per Track:	3.1 Kbytes	6.2 Kbytes
Formatted: (16 Records/Track).		
Per Disk	81.9 Kbytes	163.8 Kbytes
Per Track:	2.0 Kbytes	4.1 Kbytes
Per Sector:	128 Kbytes	256 Kbytes
Sector/Track:	16	16

We also have switch boxes and video to VHF/UHF modulators.

LUNG HWA ELECTRONICS CO., LTD.

Office & Fty: 5/F., No. 33, Pao Hsing Rd., Hsin Tien City, Taipei Hsien, Taiwan, R.O.C.
Cable: "IFTLUNGHWA" Taipei Telex: 31143 LUNGHWA Tel: (02) 914-5660 (5 Lines)
USA OFFICE: **DISTAR INC.**
2819 Glauser Dr. San Jose, CA 95133 Tel: (408) 926-1875

LDD-103SSA

* Apple II is a registered trademark of Apple Computer Inc.
* IBM, PC is registered trademark of IBM Corp.

Circle 535 on Inquiry card.



MPF-I PLUS

- A complete microcomputer system
- Detailed instruction manuals
- A full range of options and accessories
- For instructional use, plus a wide range of practical applications

Learn Computing with the Micro-Professor-IP for \$199

The Micro-Professor (MPF-IP) is a complete hardware and software system that will expose you to the amazing world of microprocessors.

A comprehensive teaching manual gives you detailed schematics and extensive examples of program code. All of this makes for a superb learning tool for students, hobbyists and microprocessor enthusiasts alike. Also serves as an excellent teaching aid for instructors of electrical engineering and computer science.

With the Micro-Professor-IP you get:

- Z-80 processor chip
- High quality 49-key keyboard
- On board 4 K-byte RAM
- On board 8 K-byte ROM including:
 - Interactive Monitor
 - Line Assembler
 - Two Pass Assembler
 - Tekt Editor
 - Disassembler
 - Language options of BASIC and FORTH.

You'll also get a lot more including:

- Built-in speaker
- 20 digit alphanumerical green tube display.
- 48 Input/Output lines
- Battery back-up circuits for RAM
- Bus expandable Z-80* architecture
- Three user's manuals
- Program storage/reading cassette interface

Options

- Student Workbook (\$15)
- Printer (\$99)
- Speech Synthesizer Board (\$139)
- Sound Generation Board (\$99)
- EPROM Programming Board (\$169)
- Input/Output and Memory Board (\$139)



MPF-I Micro-Professor

Z-80* CPU, 2K RAM expandable to 4K, 2K RAM, sophisticated monitor expandable 8K, 6-digit LED display plus a built-in speaker, cassette interface, and sockets to accept optional

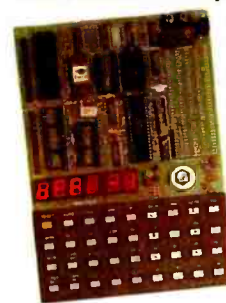

CTC/PIO, BUS is extendable. As well as being an exciting learning tool, the MPF-I is a great lowest cost board for OEM's.

Circle 321 on inquiry card.



MULTITECH ELECTRONICS INC.
195 WEST EL CAMINO REAL SUNNYVALE, CA
94087 U.S.A. TEL: 408-7738400
TLX: 176004 MAC SUVL FAX: 408-7498032

*Z-80 is a trademark of Zilog Inc.

Distributor list U.S.A.

Learning Labs, INC.
P.O. Box 122
Dalhousie, GA 30701
TEL: 404-629-1521

SIVAD INC
P.O. Box 16664,
Jackson, MS39206
TEL: 601-355-3110

Technical Laboratory Systems, INC.
P.O. Box 218609
Houston, TX77218
TEL: 713-465-9793

L.A.B. Corporation
4416 River Road
Afton, MN 55001
TEL: 612-436-1169

Etronics
3928 148th N.E.
Redmond WA 98052
206-881-0857

DIGIAC CORP.
175 Engineers Road,
Smithtown, N.Y. 11787
TEL: (516) 273-8600

Canada Future Electronics INC.

Montreal
237 Hymus Boulevard
Pointe Claire, Quebec
H9R 5C7
TEL: (514) 694-7710

OTTAWA
Boxter Centre
1050 Boxter Road,
Ottawa, Ontario K2C
3P2

TORONTO
4800 Dufferin Street
Downsview, Ontario
M3H 5S8

CALGARY
5809 Macleod Trail
South Unit 109 Calgary,
Alberta T2H 0J9

Vancouver
3070 Kingsway
Vancouver, B.C. V5R 5J7

Outside of North America mail to:
Multitech Industrial Corporation
977 Min Shen E. Road,
105 Taipei, Taiwan, R.O.C.
Tel: 02-769-1225 Tlx: 19162 MULTIC
23756 MULTIC

An Unbeatable Partner For Your Personal Computer

OUR MODEL DG-5 5¼" MINI FLOPPY IS IN MASS PRODUCTION FOR APPLE AND IBM PC
8" DSDD DRIVE · 6809 CARD · AUTO RETURN JOYSTICK FOR APPLE II
KEYBOARD · MODEM KIT · 40 COLUMN DUAL COLOR DOT MATRIX PRINTER · 40/80 COLUMN FOUR COLOR PLOTTER PRINTER FOR APPLE II AND IBM PC.

SPECIAL SOFTWARE FOR APPLE II
STRUCTURED BASIC COMPILER
APPLE II SIMULATED FUNCTION KEYS PROGRAM.

MICRO PROCESSOR — BASED ENERGY REDUCTION CONTROLLER FOR AC MOTOR (CHINESE PATENT PENDING)
MICRO PROCESSOR-BASED ELECTRONIC BRAKE CIRCUIT (CHINESE PT. NO. 17362)

*Apple II is a registered trade-mark of Apple Computer, Inc.
*IBM, PC is registered trade-mark of IBM Corp.



FOR DETAILS OF ABOVE PRODUCTS AND OUR NEW MODEL PORTABLE COMPUTER DGI, IBM PC COMPATIBLE COMPUTER DGII, AND THE FIRST COMMERCIALIZED LOW COST HIGH PERFORMANCE MINI COMPUTER MODEL DGIII FROM TAIWAN, R.O.C. PLEASE CALL:

DG CO. Dealer & Rep. Inquires Invited
2nd Fl., No. 117 Yen Chiou Yuen Rd., Sec 1, Taipei (115)
Taiwan, R.O.C. TEL: (02) 765-0497

New Product Enhances Your Apple II

ENHANCEMENT 8/16



Make Your Apple II Really More Capable And Powerful

- *Built-in: a power supply that solves the expansion and stability problem.
- *Built-in: printer interface.
- *Built-in: two floppy disc drives.
- *Built-in: 5 expansion slots.
- *Enhancement 8 can run cp/m programs.
- *Enhancement 16 can run MS-DOS, CP/M-86 and USCD P — system programs.

TERMINAL CARD



Make Your Apple II An Intelligent Terminal

- *Baud rate — 50 ~ 19.2 K
- *Data bit — 5, 6, 7, 8
- *Parity check — non, even, odd, mark, space
- *Stop bit — 1, 1.5, 2
- *Up load & down load — file transmission
- *Block mode — Yes
- *Modem connection — DTE, DCE
- *Language — BASIC language.



J.E. COMPUTER CO., LTD.

Telex: 22072 JECOMPUT Cable: "JECOMPUT" Taipei

Tel: (02) 799-6740/4 Taipei, Taiwan, R.O.C. Circle 544 on Inquiry card.



GENIUS MUSICIAN BOARD

The GMB Is Specially For Use With Apple II, Apple IIE Personal Computers

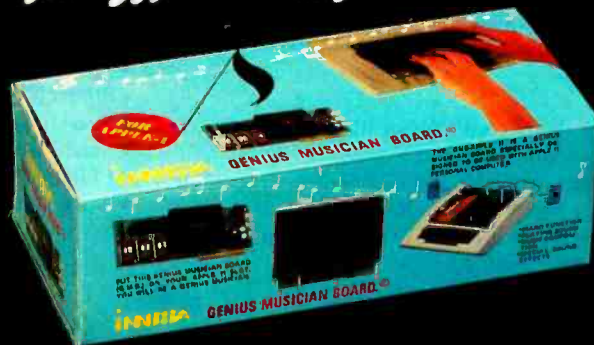

Recommended Retail Price US\$149

Agents & distributors are most welcome.

Use Our Musician Board And Become A Musical Genius!

This state of the art, compact interface card allows the user to create, play and store music. Simple insertion into slot 2 on 48 K Apple type computer is all that's required to convert a computer into a music machine.

The GENIUS MUSICIAN BOARD comes in a complete self-contained package with everything you need to hear and play computer-generated music. Along with the GENIUS MUSICIAN BOARD interface card, is included detailed instructions, keyboard coding labels, and two mini stereo speakers with audio cables. With an easy-to-obtain adaptor, you can also hook up a stereo amplifier with external speakers.

The user not only can play the Apple II keyboard as an electronic piano but also can utilize simple keyboard commands to play pre-programmed music; create custom music programs; develop and compose new music compositions; add special sound effects (gunshot, explosion, laser or rockets firing, PACMAN melody); or designate melody, tempo, chord, beat and rhythm (waltz, rumba, swing, tango, disco, blues, beguine, latin, rock, new wave). The most wonderful performance of the G.M.B. is only one 5-1/4" floppy disk may contain about one hundred popular songs with chord & rhythm, also works in progress can even be saved on a disk for later completion. The combinations are limited only by the user's creative imagination.

WRITE FOR CATALOG

Add \$1.25 per order for shipping. We pay balance of UPS surface charges on all prepaid orders. Prices listed are on cash discount basis Regular prices slightly higher. Prices subject to change

© Copyright 1983 by INNOVA COMPUTER

IND. CO., LTD. All rights reserved.

INNOVA COMPUTER INDUSTRY CO., LTD.

Telex: 10949 INNOVA Tel: (02) 760-5877/8

1st Fl., No. 1, Alley 2, Lane 929, Min Sheng E. Rd., Taipei, Taiwan, R.O.C.

Circle 545 on Inquiry card.

U.S.A. OFFICE: SUNDELIGHT INT'L INC.

933-C S. GREENWOOD AVE.

P.O. BOX 923 MONTEBELLO, CA. 90640

TEL: 213-728-5023 TLX: 292448 SUND OR

Apple II is a registered trademark of Apple Computer, Inc.

MULTITECH GIVES YOUR APPLE A FACELIFT

This array of high quality peripherals from Multitech not only adds to the aesthetic value of your personal, they also transform it into a more powerful, more productive pleasure or business machine.



The ErgoVision high resolution monitor packs powerfully clear graphic capabilities into a tilt and swivel housing that will keep long hours of computing from turning into a pain in the neck.

- *High resolution 12" non-glare screen
- *P31 Green or G134 Amber phosphor
- *NTSC composite video input interface
- *Compatible with most popular micros
- *Ergonomic design with full tilt and swivel capabilities
- *Video bandwidth of 14 MHz
- *Resolution of 1000 lines center, minimum 800 lines corner
- *Scanning frequency of 15750Hz horizontally, 55Hz vertically

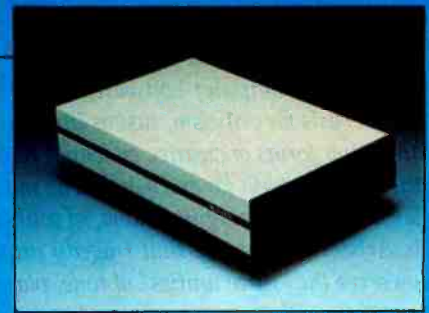

The Slimmer is a half-height 5 1/4" thin floppy disk drive that is compatible with some of the most popular computers on the market today, including the Apple II.

- *Cost effective on-line storage
- *143K byte storage
- *35 track compatible
- *Super slim profile
- *Fast positioning time
- *High reliability
- *Safe media protection



The AccuFeel keyboard offers you the comfort, convenience, and productivity you just can't get with original keyboards.

- *Models plug-compatible with the Apple II and IBM PC
- *Positive tactile feedback
- *Low profile, sculptured and detachable keyboard
- *90 keys including numeric keypad and 16 user function keys
- *Ergonomically designed with DIN specification compliance
- *Auto-repeat on all keys
- *6 foot cable for portability
- *High cost effectiveness
- *Convenient key layout

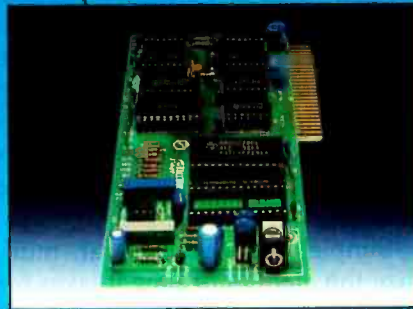

With the SSB-Apple Speech Synthesis Board you too can program your Apple II to talk to you.

- *High performance Texas Instruments TMS5220 speech synthesis chip
- *1,200 word English vocabulary
- *Apple II plug-compatible
- *On-board audio amplifier and speaker
- *Wide application range

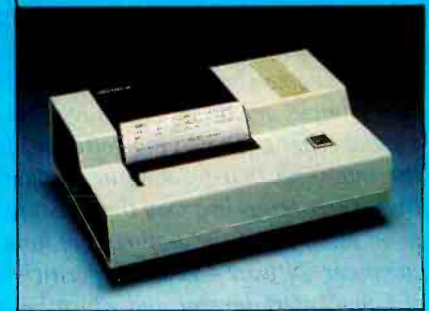

The MIC-40 thermal/dot matrix printer offers hard copy at a very soft price, packing features such as:

- *40 characters/280 dots per line
- *120 CPS (150 to 180 LPM)
- *5x7 dot size alpha-numerical characters
- *7x8 dot size graphic characters
- *Full 96 ASCII character and 50 graphic character display
- *Centronic parallel interface
- *Optional RS232C and current loop serial interface

MULTITECH INDUSTRIAL CORPORATION
 315, FU HSING N. ROAD,
 TAIPEI 104, TAIWAN, R. O. C.
 TEL: (02)713-4022 (20 Lines)
 TLX: 23756 MULTIIC, 19162 MULTIIC

MULTITECH ELECTRONICS INC.
 195, WEST EL CAMINO REAL
 SUNNYVALE, CA 94087, U.S.A.
 TEL: (408) 773-8400
 TLX: 176004 MAC SUVL
 FAX: 408-7498032

Circle 322 on Inquiry card.

IBM is a registered trademark of IBM Corporation

Shaping Consumer Software

Trip Hawkins of Electronic Arts explains his criteria for judging software and presents his view of the programmer as artist

by Phil Lemmons and Barbara Robertson

The Aesthetics of Software

To judge computer software, we first need a basis for criticism, just as literature and other forms of creative endeavor have their own criteria for excellence. The most famous basis for judging drama, of course, is Aristotle's doctrine that tragedy must preserve the "three unities" of time, place, and action. But computer programs have an important characteristic that literature lacks: multiple branching. Computer programs have hundreds and thousands of conditional steps, and a user can run a program many times without ever taking the same path twice. Furthermore, the computer has special characteristics as a medium.

When William M. "Trip" Hawkins, president of Electronic Arts, talks of the need for home computer software to be "hot, simple, and deep," he is suggesting a set of criteria for judging software. In the interview that follows, he explains those three terms in a way that amounts to an essay about the aesthetics of home computer software—a basis for criticism of home entertainment and educational programs. Hawkins's views should prompt discussions among computer users about the nature of software, and in time those discussions may form the basis of an aesthetic to stand alongside those of literature and art.

BYTE West Coast Bureau Chief Phil Lemmons and West Coast Technical Editor Barbara Robertson interviewed Hawkins at Electronic Arts' office in San

Mateo, California. BYTE's questions to Hawkins appear in boldface, and Hawkins's responses follow in lightface.

What Software Should Be Like You have said that software must be "hot, simple, and deep." Did you borrow those terms from some latter-day Marshall McLuhan?

No, I made them up. "Simple" came from Lisa. The first time I started talking about computers as a medium was when I started talking to people about Lisa. At Apple we were trying to get people to understand why Lisa software was only possible with Lisa hardware. And the medium is the message.

"Simple" just means I can minimize the amount of time it takes for somebody to get into the product. In that sense, "simple" can apply to any kind of application, whether it's a game, an educational product, something to satisfy the intellectual curiosity of an adult, or something that pays your bills for you.

When I worked at Apple, we had a struggle with Lisa in the early going. The engineers wanted to know whether or not the person who would be operating the Lisa would be a naive or sophisticated user. We finally convinced them it really didn't matter whether it was a CEO or a secretary—everybody considers his

or her own time precious and wouldn't want to spend any time learning to use the computer and software.

And in the consumer market, leisure time is precious, too, whether it's Johnny's leisure time after school or a parent's on the weekend. Nobody wants to spend time studying a manual to play a game. The idea of having to read a manual to play a game is pretty scary in itself.

The "simple" part has to do with how the program is presented on the screen and what kind of controls you use to interact with it. For example, Mule is an economic simulation game, and there's a whole lot going on. There are a lot of financial transactions, but you never do anything except move your joystick and push the button.

"Hot" has more to do with how you take advantage of what a specific computer can do. For example, the Atari offers much better sound than the Apple, so it's important for an Atari machine and an Atari owner to get a product that takes advantage of that. "Hot" means how well this product uses the heat that's in this medium, how well it takes advantage of the special things it can do.

You're always trying to take advantage of the maximum rate at which somebody can absorb information. And getting the medium as hot as

possible makes it easy to do that.

The computer really has four things going for it as a medium. Two are sound and video—you have to use sound and the screen to the fullest advantage. The third asset of computers is their interactivensness—the natural feedback loop. People get a lot just from the machine making a funny noise because of some action they've taken. The fourth asset is what I call "hidden machinery," the fact that the computer, because it's a data-processing machine, can take an enormous amount of information and keep track of it, providing a structure for it that is completely invisible to the consumer.

The best example I can think of is Flight Simulator. All you can see on the screen is the view out the cockpit and the controls spinning around, but there's all this scaffolding behind it that will sustain you in the air, and you don't have to deal with any of that.

Flight Simulator creates a realistic experience. Realism usually is based on data, and the more data you have for a situation, the more realistic it is. But if that data is apparent to you as you use the program, then the complexity is going to be apparent to you. And that's the problem. Imagine what Flight Simulator would be like if I played it as a board game. It would be a disaster. I'd be constantly computing my velocity, my altitude, and all kinds of other things.

The same thing goes for adventure games. Think of an experience like Dungeons and Dragons, where you're trying to create a very realistic adventure. There are all these charts and tables and complicated manuals, and you're trying to figure out how much weight each person's carrying

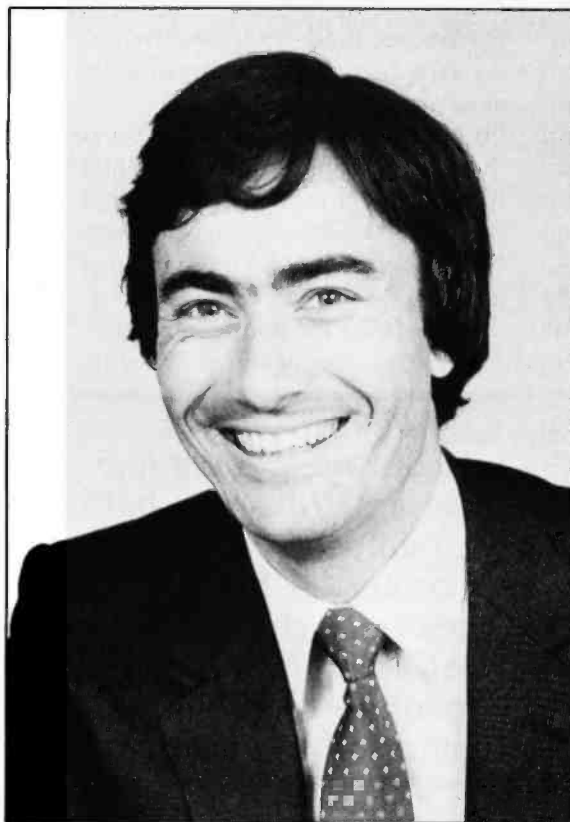

Trip Hawkins

and where he's holding different weapons, how much each one is paid for the weapons, what kind of damage the weapons do when they hit, what percentage of the time they hit, and what kind of monster they're attacking. You have to keep track of all this data. Computers are really good at keeping track of that, and they should be used to hide the machinery.

Getting a program to be hot is a combination of taking advantage of all four of a computer's assets. I think you're failing to fulfill the promise of home computing if you're not pushing those as far as you can with a particular idea. Video games tend to be purely visually oriented; sound effects haven't been that far advanced. With a really good video game you've got some interesting interaction, some interesting graphics, and some interesting sound, but you're not taking advantage of the hidden machinery.

That's partly why "deep" comes in. A lot of video games are simple and hot, but almost none of them are deep. A lot of that has to do with the fact that an arcade is a crazy place

with lots of noise and distraction. You can't take time to think about what you're doing; you've just got to be reacting. And the experience has to be over and done with in 60 seconds. In the home you don't have that constraint, so you can do things differently and offer greater variety.

I don't think anybody's going to have sustained interest in something that's not involving them at all mentally. A mindless reaction is OK for a few minutes' relaxation, but it's certainly not going to become a large portion of your leisure time over years.

Parents don't particularly want to encourage that, anyway. What they really want is products that have *depth*. Again, if I can use Mule as an example, it's a very complicated economic simulation. But when you start playing, there's a beginner version, so some of the complexity is very deliberately stripped out of it, and you only have to learn how to move the joystick and press the button. There are some very interesting music and graphics, and it's still more complicated than a typical video game. In other words, you have to learn how to do a few things and understand a few mechanisms on the screen. Once you get those down, you know how to play.

But learning how to become a good player of the tournament game is totally different—by the time you're playing for the fiftieth time, you're still learning things about it. And a lot of the basic rules of economics are cleverly concealed, so you learn things like the learning curve theory of production, economies of scale, basic supply and demand and bargaining, acquired resources and scarcity or controlling price through

market share, and collusion. It's phenomenal how much is going on.

Even so, when you start out it can be very simple; in fact, you can do other things in the game to handicap people. If, for example, you have an adult playing with a 10-year-old for the first time, the child can be given a special character that has more points and has a longer turn, and the adult can be handicapped. The way you handicap adults is to make them humanoids, and since the game takes place on a foreign planet, you assume that its harsh climate affects the humans.

Simple, Hot, and Deep in Other Software

Do ideas like "simple" and "hot" apply to both educational and entertainment software?

Yes. Anyone who tries to make a distinction between education and entertainment doesn't know the first thing about either. I see the meat of this market in products that combine entertainment and education and don't consciously try to separate the two. A part of our market is still pure fun, and another part is pure learning, but I think the meat of the market is those two in combination.

We see two other parts of the market as distinct. We call one "personal development" just because that's a better way of describing the way an adult thinks about education. In more cases than not, you're indulging a particular intellectual curiosity about how computers work, about music, art, chemistry, or anything you feel like learning about or tinkering around with. A computer is a very interactive playmate for doing that.

The fourth market after entertainment, education, and personal development is home management. That divides into information management and financial management. Information management includes word processing, retrieving information from other computers, and so on. And then there's financial management, which includes things like how to make financial planning decisions and how to figure out how to finance a new house or get your taxes

paid.

Do you see those things as straightforward business-like applications or as games as well?

I think there's a direction we can go there, but people still fundamentally want to get the job done. I think we can make the experience of getting the job done a lot more interesting.

Sound effects for bouncing checks?
I think there probably will be some

We're trying to encourage people like Gahan Wilson to get involved with the computer because they're in the business of using an artistic medium to evoke an emotional response.

playfulness for that sort of thing, but it had better not get in the way of efficiency. Simple applies equally well across all those categories. Hot also applies equally well because you're trying to figure out how to take what a specific computer can do and make it as compelling as possible. Deep really has more to do with whether or not I find the bottom of the product quickly. Clearly, I don't want to find the bottom of it quickly; I want it to continue to be interesting, continue to unfold.

We understand some of your programs are going to involve interesting collaborations.

We're trying to get people like Gahan Wilson involved with the computer because they're in the business of using an artistic medium to evoke an emotional response. Most people in computers haven't thought about the medium that way. We're really trying to encourage that. I think it's going to take a style of software development that's more accessible, where programming is no longer exclusively the province of the people who know how to handcraft assembly code. People who know how to handcraft assembly code seldom are as aesthetically oriented as Bill Budge or as oriented toward emotion as a

great film director. You're going to start to see more collaborative efforts.

Rock, Flicks, and Object Code

Every artist shapes a creation or performance around the capabilities of the equipment used. The musician must work with vocal cords or the harmonics of an instrument. The actor calls upon facial expression, body movements, and the particular characteristics of the film camera. The software programmer, too, must shape a program to existing technology. But the personal computer goes one step beyond by allowing interactiveness. A performance becomes an integration of the user, the programmer's software, and the hardware. Yet the programmer, unlike the performer, takes a back seat to the instrument—the computer—when it comes to recognition. With the exception of a few famed instruments such as the Stradivarius violin, praise for the equipment over the performer does not occur anywhere but in the software programming industry.

Still, the entertainment industry provides parallels for the software industry. Both combine the skills of many people to produce a product—be it an album, a motion picture, or a program. Financial arrangements, however, vary considerably.

In the popular music industry, the songwriter, the musician, and the producer generally get royalties. The musician divides royalties with an agent, a business manager, a personal manager, and perhaps a public relations firm. In the motion picture industry, the company is the producer. Screenwriters get fees or perhaps a small percentage of the film's earnings. The actor gets fees, a percentage, or both, and usually pays some part of the earnings to an agent, a business manager, a publicity agent, and so on.

The software industry is different. The programmer may be an employee who writes code to implement someone else's idea, or he may generate the original idea, the detailed design, and the code itself. In the latter case, the programmer can sell the program for a flat fee, give it to a publisher in exchange for a royalty, or produce copies and contract with a distributor to sell to retail stores or directly to users.

Trip Hawkins and Electronic Arts are

MICROHOUSE

MONITORS

Hitachi I	\$299
Hitachi II	499

GRAPHICS

Fastgraphs	\$189
D Graph	199

PRINTERS

Prowriter Parallel	\$429	Smith Corona Tractor	\$139
Prowriter Serial	629	Banana	239
Smith Corona TP-1	529	Grappler Plus	134

LANGUAGES

Basic 80 Compiler	\$289	Microsoft Cobol 80	\$539
Basic 80 Interpreter	259	muLisp/muStar	144
Msort	149	muLisp/muMath	189
Fortran 80 Compiler	289	C Compiler	189

DATABASE

Dbase II	\$439	Tim III	\$275
Dbase II/Dutil	499	Datastar	169
Dutil	68	Infostar	279
Quickcode	219	Supersort I	149

COMMUNICATIONS

US Autodial	\$479	Hayes Smart Modem	\$239
Password	379	Micromodem II	309
Autolink 300	179	Hayes Chronograph	219
Hayes 1200 Baud	569	Crosstalk	117

FINANCIAL

Supercalc	\$125
Supercalc II	179
Visicalc	189
Visitrend/Plot	228
Multiplan	194
Calcstar	99
Home Accountant for IBM	99
Planstar	395
Scratchpad	199
Money Decisions	79

WORDPROCESSING

Wordstar	\$279
WS/MM	349
WS/MM/SS	444
Starindex	119
Final Word	199
Superwriter	175
Spellguard	119
Spellstar	149
Mathstar	89
TMaker III	189

IBM HARDWARE

Quadboard 64K	\$ 295
Quadboard 256K	479
Quadboard II 64K	295
Quadboard II 256K	479
Quadcolor I	235
Microsoft 64K	259
Microsoft 128K	379
Microsoft 192K	519
Microsoft 256K	624
Datamac 12 Meg Int	1899

We offer savings on the finest in software including Micropro, Sorcim, Ashton Tate, Fox and Geller, Microsoft, Supersoft . . . and excellent buys in hardware peripherals, printers memory boards, modems, diskettes and supplies.



MEDIA

Maxell FD-1	\$40
Maxell FD-2	\$49
Maxell MD-1	\$31
Maxell MD-2	\$44

MICROHOUSE

A WISE CHOICE FOR
ALL MICRO PURCHASES!

TWO LOCATIONS TO SERVE YOU BETTER

TOLL FREE PHONES:

1 • 800 • 523 • 9511

BOX 499, BETHLEHEM, PA 18016

OR

1 • 800 • FOR • SURE

P.O. BOX 4380, SPARKS, NV 89432

Dept #100

Prices subject to change without notice

It's easy to
do business with
MICROHOUSE

Full tech support
Lower prices

We accept
MasterCard, Visa
American Express
and purchase orders

leaders in the movement to treat programmers as artists and reward them accordingly. As Hawkins notes, however, the analogy of the software business to show business can easily be strained.

When did you get the idea to organize this software house on a different model?

At Apple, while we were working on Lisa. Lisa software was inhibited by the need to have so many people simultaneously in agreement. That would be difficult regardless of the collection of people involved.

It occurred to me that in film, television, books, and other forms of entertainment media, artists all work kind of independently. And already by that time there were certainly examples of that in programming. Bill Budge, for example, had done some space games and then he worked for Apple for six months.

I think a lot of software people have plunged into building a huge software organization without realizing the limits to growth that eventually you're going to have to live with.

What are those?

The "mythical man-month," for one. Nine women can't make a baby in a month. And there comes a point in a software project where if you add more people it'll never get done. And I think that you have to find ways to keep things decentralized. Our model of the world is sort of the ultimate in decentralization.

The question is, how can we make these talented programmers and program designers who are working scattered all over the world as productive as possible? Once we can answer that, making the company grow indefinitely is just a function of finding the best talent and leveraging it more effectively than someone else can.

We have all the advantages that go with a small company. We can have a more personal relationship with the programmers. Apple certainly wasn't a huge company, but it had a lot of trouble, as many corporations do, dealing with the idea of putting the software people on a pedestal and treating them differently from everyone else. I realized, hey, they are dif-

ferent—let's put them up on a pedestal.

Based on your view of home computers as a new medium and of programmers as artists, how have you organized Electronic Arts differently from other software houses?

The most important department is the talent department, and that's staffed with producers. Producers

Our producers are very important people—they're a little like book editors, a little like film producers, and a lot like product managers.

basically manage the relationship with the artist. They find the talent, work out product deals, get contracts signed, manage them, and bring them to their conclusion. The producers do most of the things that a product manager does. They don't do the marketing, which in some cases product managers do. They don't make decisions about packaging and merchandising, but they do get involved.

They're like book editors, then?

Yes, they're a little like book editors, a little bit like film producers, and a lot like product managers. I think the biggest time sink for a producer over the full course of the product development is working with the software artist while he's finishing the software—turning around new releases and getting the bugs eliminated and getting manuals straightened out. Usually what happens on the manual is that the original artist will provide something in some rough form, and the producer will figure out how to turn that into a final manual.

Do producers get salaries?

Yes, they're on salary. Some day, when it becomes really easy to figure out a measure of a producer's effectiveness, these people will get a piece of the action. Their performance will be based on how well the products do. I'm already trying to get them to think like portfolio managers—you have this much cash to invest in

terms of advances, and you've got this kind of bottom line to play with in terms of what royalty percentage you can give out, so how much can you spend on the overall marketing, that sort of thing. The idea is to figure out how to produce the most revenue from that. And whether you want a couple of really expensive high-risk, high-reward possibilities, or some of those balanced with some inexpensive 18-year-olds and one more expensive educational group or whatever.

What are the producers' backgrounds?

We have five of them full-time right now. Three of them worked at Apple; in fact, two of them worked directly for me. One was product marketing manager for all the Lisa software, and she's very good at working with engineering people. The other two people from Apple had similar kinds of reputations for being good at working with engineering people. One producer sold computers for IBM and then became an executive recruiter. He signed Gahan Wilson. Our fifth producer, who came from one of our competitors, Automated Simulations, was basically doing all of the company's product marketing. She's basically a social scientist.

Are most of your contracts with individuals or with groups?

It's a range. You have guys like Bill Budge who are individuals and then you have guys from a company like Childware, where it's a group of about four. Then there's another category where there might be one key individual, somebody like Dan Bunten at Ozark Softscape or Jon Freeman at Free Fall Associates. Dan Bunten's the guy who did Cartels and Cutthroats, Cytron Master, and Computer Quarterback. He did those pretty much on his own, but now he has his brother and some other family members involved, and they set up a separate company.

Then you have people like Jon Freeman. He specializes in design—game design, not even program design. His wife, Anne Westfall, specializes in program design. And then there are two other guys that they work with; one is strictly a program-

mer, and the other is a combination programmer and game designer. so it's a little bit of everything. Actually, I guess right now the solo performers are the exception. We have only four or five who can really work that independently.

Do you, like book publishers, get unsolicited products, unsolicited disks?

We do. We expect that their volume is going to go up a lot once we're on the market.

Do you welcome that?

Absolutely, although you tend to have a very low hit rate—about one in a hundred or worse. I've already been through that at Apple, and Rich Melmon. Our vice president for marketing, went through it at Visicorp.

When a programmer signs a contract with you, how is it likely to make his life different than if he were doing software on his own?

It's a really big difference. The guy to talk to about that would be Bill Budge because he recently was running his own company. I know in Bill's case,

there's a lot of time you spend answering the phone, talking to distributors, getting orders, approving artwork or packaging, getting labels printed, doing mailings to dealers, just doing a whole lot of stuff that I find interesting. People like Bill

In some situations now we're much happier to be dealing with lawyers rather than programmers because they don't get freaked-out when they first see a contract.

find it thoroughly tedious. Some programmers out there enjoy it, and I think in some cases it will prove to be their downfall because they're not very good at it, but they like it, and so they'll do a mediocre job both running a company and trying to do the software.

Do you expect to be dealing with

agents for programmers some day? Sometimes we already do. They do exist. In some cases they're just lawyers, but, depending on the amount of experience they have, they can be very smart. There are situations right now where we're much happier to be dealing with lawyers because they don't get freaked-out when they first see a contract.

Contracts with Programmers

What are contracts with programmers like now?

The typical software contract spends most of the time talking about maintenance and support and stuff like that. Once the kind of software that we buy from an outsider is done, it's done, so there's less emphasis on issues like support. There's more emphasis, though, on the rights to different kinds of things. So in fact it's really much more closely modeled after a recording contract. We want to make sure that if we ever want to do "greatest hits of 1983," we can put all the programs on one disk.

What about the fundamental financial aspects of the contract?

It really boils down to a royalty rate on products that we manufacture, which is the market range, typically 10 to 20 percent of the wholesale revenue. Some manufacturers are more out of sync with the market than others, but I think over the next year the rates will become reasonably standard, the same way they are in the record business. Right now they're still all over the map.

How does the range in software compare with what's available in books?

We don't actually encourage too much of a range. So much of our business is driven by percentages of sales that you can't really justify paying a much higher percentage of sales to one guy than another guy. What you're really looking for is higher total revenue on a better product. If you look at our marketing costs, sales commissions, things like rack servicing fees and administrative and R&D budgets, they all tend to be set up as a percentage of sales. What you're really looking for in a big hit product is something that is going to do so much more sales volume that all of

40-50% Savings On Software



As a member of the Software of the Month Club, you'll receive:

- SAVINGS:** high volume buying means low prices to members
- SELECTIONS:** members to decide best sellers — others also available
- NEWSLETTERS:** tips & "how-to" by consultants
- HARDWARE SPECIALS:** co-op savings
- Membership registration fee \$25.** Join now for only \$6. (limited time)
- No minimum purchase required.**

BY TEL 1060

Software of the Month Club, Inc.
953 Mission St. Mint Mall
San Francisco, CA 94103

Name: _____
Address: _____
City/State/Zip: _____

Enclosed is \$6. Please enroll me in the Club.

Check or Money Order VISA MASTERCARD

Exp. Date: _____
Card #: _____
Signature: _____



MEMORY PLUS MORE

LSI 11 MEMORY

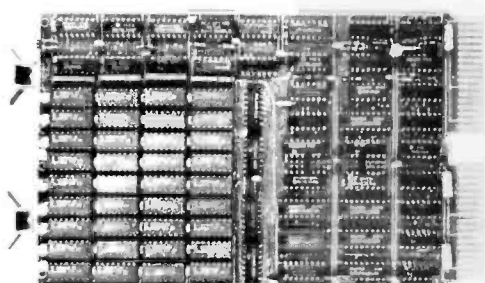

512 SINGLE BOARD W/RS232-C PORT MEMORY FOR IBM PC, XT

- On board parity with interrupt on parity error.
- Addressable as a contiguous block in 64KB increments thru 1 megabyte.

SINGLE QTY. PRICE:
512KB \$545.00

FREE with purchase of memory.

MEMDISK 1 Allows memory to emulate disks.

MULTIBUS MEMORY

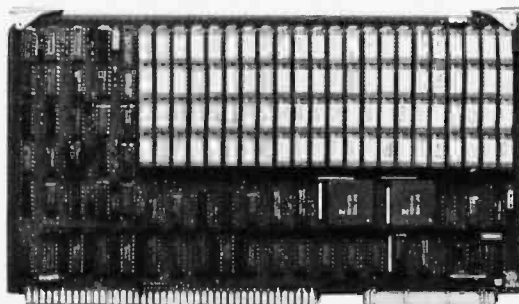

256KB TO 1 MB SINGLE BOARD LSI 11 MEMORY

- Control Status Register (CSR).
- On board parity generator checker.
- Battery back-up mode.

SINGLE QTY. PRICE:
256KB \$595.00
1MB \$3995.00

512KB TO 2MB EDC SINGLE BOARD MULTIBUS MEMORY

- Pin to Pin MULTIBUS compatibility for both 8 bit and 16 bit systems.
- Addressable up to 16 megabytes.
- On board parity with selectable interrupt on parity ERROR.

OR

- Error Detecting and Correcting (EDC).

SINGLE QTY. PRICE:

	Without/EDC	W/EDC
512KB	\$895.00	\$1495.00
2MB	\$5995.00	\$6495.00

MEMORY PLUS MORE from Chrislin means your getting the best in performance and pricing in the market today. Incorporating the 256K RAM technology into the LSI and Multibus memories offers you the most recent technology available. Act now while quantities still last.

140MB WINCHESTER DISK SYSTEM FOR LSI BASED SYSTEMS

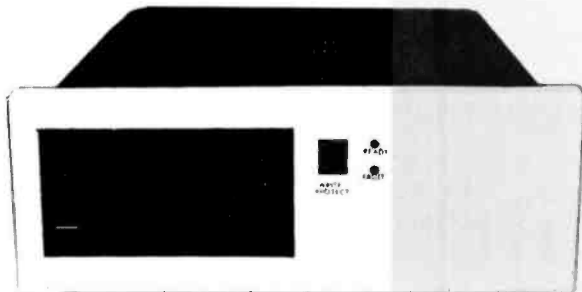

CI-1340-WF: 140MB formatted Winchester (8") disk system w/controller and 2MB floppy (8") backup w/controller.

PRICE:
\$9995.00

"OFFERING QUALITY WITH AFFORDABLE PRICING"



Chrislin Industries, Inc.

31352 Via Colinas • Westlake Village, CA 91362
Telephone: 213-991-2254 • TWX 910-494-1253 CHRISLIN WKVG

IBM is a Trademark of International Business Machines. Multibus is a Trademark of Intel Corporation. LSI is a Trademark of Digital Equipment Corporation.

those percentages start to work in your favor.

So all your programmers will be getting the same royalty?

No, I wasn't trying to suggest that. A certain amount is a function of bargaining and a certain amount is just a function of what we think is fair. The rates are not widely disparate. The thing that does change is the amount of the advance, and that's a function of the track record of the software artist. If he or she really has a strong track record or if the software development method used is clearly more expensive than somebody else's, but we think it's the right method, then we're going to pay for it.

For example, right now we're working with Childware, a group that specializes in educational software. When people from the company came in and showed us their first script, it was something like 32 professionally drawn pictures on a storyboard. That kind of richness of communication is going to cost you.

Some of these groups now have a staff graphic artist and a staff musician, and they'll have certain expenses built into the way they do the development.

One other point I wanted to make about the royalties is that we divide things into three categories. There are royalty rates on products that we are actually manufacturing. There are two subcategories there. One is products where the programming is done by the original artist, who gets a residual royalty rate. If it's a derivative version that's on a machine in which the artist did not do the original programming, he still gets some royalty, and that's worked out.

The second category is licenses. For example, the Bolivian government says, "We'll pay you \$100,000 just for the rights to convert Pinball Construction Set to Bolivian." If there's a straight license, a much higher percentage of that goes to the artist because we don't have to do any manufacturing and distribution.

The third category really has more

to do with merchandising. We may want to create a product specifically for merchandising, but we're not the manufacturer. For example, a T-shirt. The royalty rate there will be very low because we're not anticipating making any money on it.

Research and Development

You also have a research and development department. With the software written mostly outside, what does the research and development department do?

Develop proprietary software tools that our software artists can use to build products faster and to build products that they couldn't build on their own.

Utilities that construct graphics for a particular machine?

Let me talk short term and then long term. In the short term there are things like software theft protection, assistance in getting up on a machine that the particular artist is not familiar with, and assistance with sound. It's more the nuts and bolts kind of thing right now.

In the long term, we're going to put together a workstation that is specifically designed for creating the kind of software that we want to create. And the development system will have things like languages and debugging tools and compilers, and it'll have a lot more memory and a lot more processing power than any of the machines that the consumer is ultimately going to own, today or in the future.

You're developing your own compilers?

We're not necessarily doing all of the development work ourselves. But we already have a FORTH compiler that runs on all four of our target machines for this year—the Apple, the Atari, the Commodore 64, and the IBM PC. We're bringing it up on our first version of the development system. We might have toolkits for sound and graphics, and so on. ■

Phil Lemmons is BYTE's West Coast Bureau Chief. Barbara Robertson is West Coast Technical Editor. They can be reached at McGraw-Hill, 425 Battery St., San Francisco, CA 94111.

Real-Time C

for 8080, Z80

A Run-Time Library for Whitesmiths' C 2.1

- Fast execution
- ROMable
- No royalties
- Fully reentrant machine support
- CP/M file support
- Error checking
- Usable with our AMX Multitasking Executive

Real-Time C \$ 95
 manual only \$ 25
 source code \$950

Intel mnemonic \$ 50
 to A-Natural converter

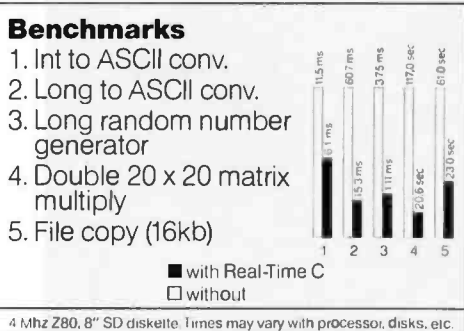

AMX and Real-Time C are trademarks of KADAK Products Ltd.
 A-Natural is TM of Whitesmiths Ltd. CP/M is TM of Digital Research Corp.
 Z80 is TM of Ziog Corp.

KADAK Products Ltd.

206-1847 W. Broadway Avenue
 Vancouver, B.C., Canada V6J 1Y5
 Telephone: (604) 734-2796
 Telex: 04-55670

INTRODUCING CUBIT™ FROM MICROMAX.

micromax
INNOVATORS IN MICRO-COMPUTER SOFTWARE

CUBIT™

FOR THE APPLE® COMPUTER

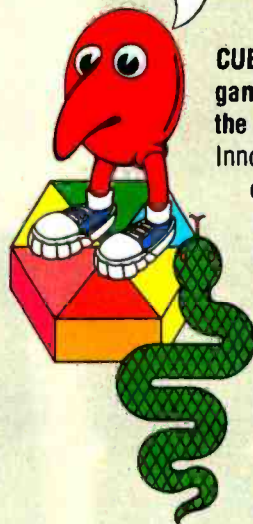

CUBIT. The only game of its kind for the Apple Computer.

Innovative, new and colorful. Cubit offers an extra dimension. It transforms a two-dimensional screen to a 3-D arena.

Cubit offers more than just the hand/eye coordination of typical shoot'em-

up games. It offers fast-moving, action filled, strategy based entertainment. And you don't have to be a concert pianist to handle the controls. Simple to learn, yet enormously challenging to master. Playable with both joystick and keyboard.

For 48K Apple Computers with 3.3 DOS. Enjoyable in black and white, but a whole lot more fun on color monitor.

Look for our next game, to be released soon.

Dealer/Distributors — Please contact us for details on Cubit and our Apple and IBM PC line of products.

Micromax Systems, Inc.
6868 Nancy Ridge Drive
San Diego, California 92121
(619) 457-3131

See us at forthcoming Applefest and Comdex shows.

Apple is a registered trademark of Apple Computers, Inc.

micromax™
INNOVATORS IN MICRO-COMPUTER SOFTWARE

Dealer Inquiries, Circle 305 All others, Circle 306

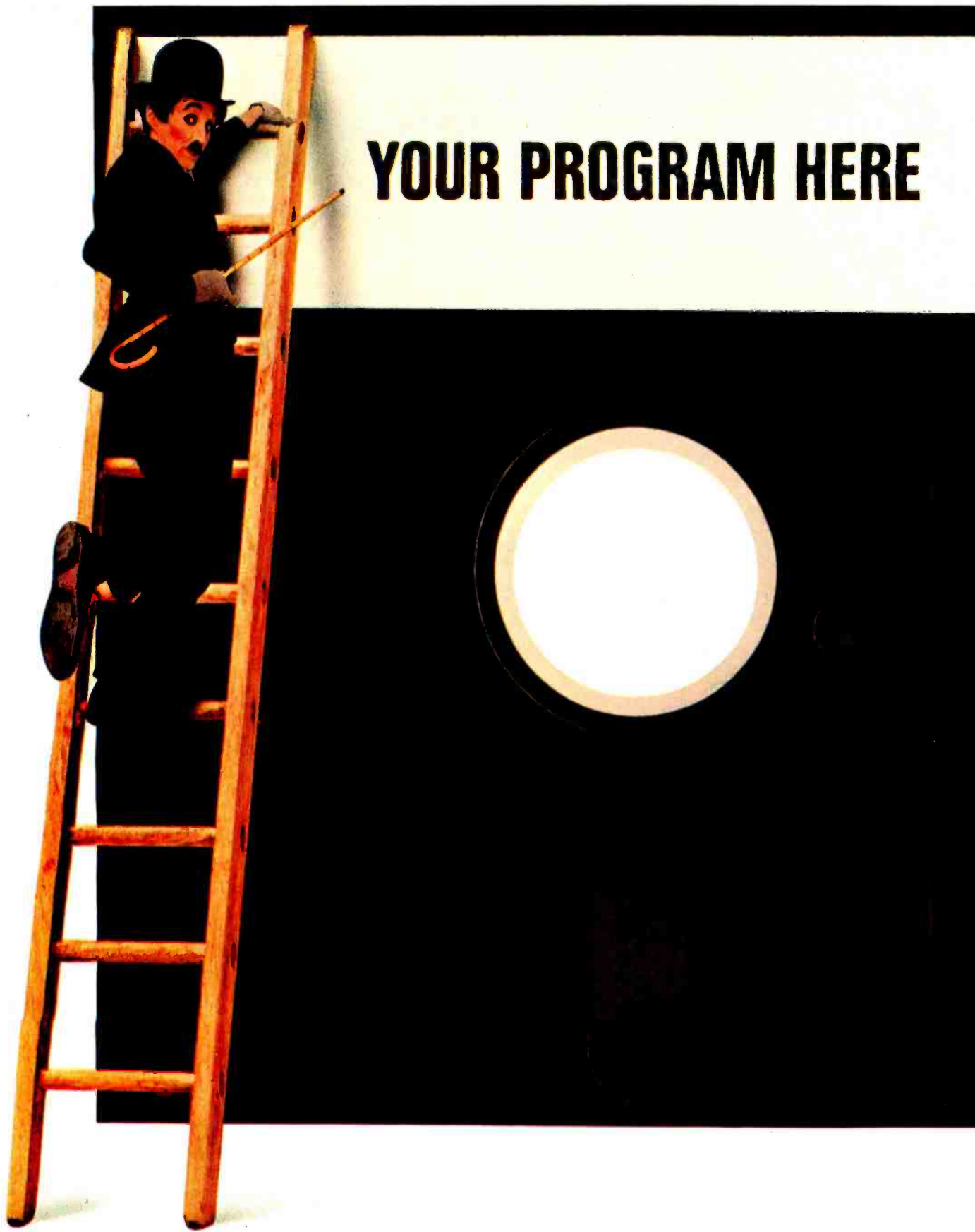

YOUR PROGRAM HERE

The Chaplin character licensed by Bubbles, Inc., S.A.



The best software for the IBM Personal Computer. Could it be yours?

Attention, all programmers. Here's a chance to reach the top.

If you've written software that's completed and runs on the IBM Personal Computer, we could be interested in publishing it.

(We also could be interested if it runs on *another* computer. If we select your software, we'll ask you to adapt it to our system.)

But be advised.

Our expectations are great.

Because the software we publish must be good enough to complement IBM Personal Computer hardware. In fact, the more you take advantage of all our hardware capabilities (see the box at right), the more interested in your software we become.

Think about incorporating color graphics into your program, for example.

Use sound. Consider the power of our keyboard and remember to utilize the ten programmable function keys.

In all cases, we're interested in "friendly" software — with emphasis on quality and wide appeal. Programs with the greatest chance of being published must be easy to use, offer a better way to accomplish a task and provide something special to the user.

What kinds of programs? All kinds.

Education. Entertainment. Personal finance. Data management. Self improvement. Games. Communications. And yes, business.

We select programs that will make the IBM Personal Computer an even more useful tool for modern times.

IBM PERSONAL COMPUTER SPECIFICATIONS

User Memory 64K-640K bytes	Display Screens Color or monochrome High-resolution 80 characters x 25 lines Upper and lower case	Permanent Memory (ROM) 40K bytes
Microprocessor 16-bit, 8088	Operating Systems DOS, UCSD p-System, CP/M-86†	Color/Graphics <i>Text mode:</i> 16 colors 256 characters and symbols in ROM
Auxiliary Memory 2 optional internal diskette drives, 5¼" 160KB/180KB or 320KB/360KB per diskette	Languages BASIC, Pascal, FORTRAN, MACRO Assembler, COBOL	<i>Graphics mode:</i> 4-color resolution: 320h x 200v Black & white resolution: 640h x 200v Simultaneous graphics & text capability
Keyboard 83 keys, 6 ft. cord attaches to system unit 10 function keys 10-key numeric pad	Printer All-points-addressable graphics capability Bidirectional 80 characters/second 18 character styles 9 x 9 character matrix	Communications RS-232-C interface SDLC, Asynchronous, Bisynchronous protocols Up to 9600 bits per second
Diagnostics Power-on self testing Parity checking		

So, if you think your software is the best, consider submitting it. If it's accepted, we'll take care of the publishing, the marketing and the distribution. All you have to do is reap the benefits of our royalty terms. And you're free to market your program elsewhere *at any time* even if you license it to us.

We're offering the ladder. Think about taking the first step.

For information on how to submit your program, write: IBM Personal Computer,

External Submissions,
Dept. 765 PC, Armonk,
New York 10504.



The IBM Personal Computer A tool for modern times

For more information on where to buy the IBM Personal Computer, call 800-447-4700. In Alaska or Hawaii, 800-447-0890.
†UCSD p-System is a trademark of the Regents of the University of California. CP/M-86 is a trademark of Digital Research, Inc.

Is your personal computer TOO personal?



Lets face it!

It's difficult to envision a business environment where only one person needs access to the daily statistics of the business. The Salesman wants to know if his customer's product shipped. The Accountant wants to know if the bills are paid. The Secretary has to get that letter out. You can't afford to keep them waiting.

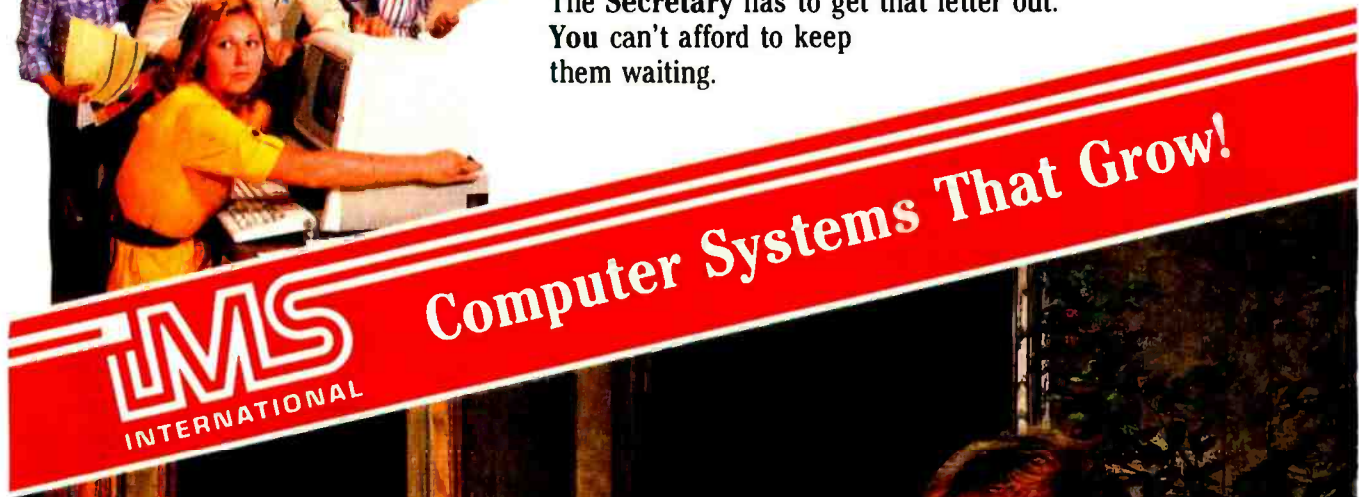

IMS
INTERNATIONAL

Computer Systems That Grow!



The unique architecture of the IMS Multi-processor System allows all functions to be performed simultaneously!

Choose from the IMS family of expandable computers to fit your business.*

*4 user 5000IS System shown. Other IMS systems expandable to 8 and 16 users.

Call or write today for the location of your nearby IMS dealer.
Toll Free: 1-800-648-7979
In Nevada call: (702) 883-7611

IMS
INTERNATIONAL

2800 Lockheed Way, Carson City, Nevada 89701 • Telex 910-395-6051

We Build Computers As If Your Business Depended On Them

- | | | | | | | | | | | | |
|---------------------------------|-----------|------------------------|---------|-----------|--------|-------------|-------------|--------------------------|-------------|----------------------|--------------|
| IMS INTERNATIONAL DISTRIBUTORS: | Argentina | British Virgin Islands | China | Greece | Israel | Malaysia | New Zealand | Saudia Arabia | Spain | Turkey | U.S.A. |
| | Australia | Canada | Ecuador | Hong Kong | Italy | Mexico | Philippines | Republic of South Africa | Sweden | United Arab Emirates | West Germany |
| | Austria | Chile | France | India | Korea | Netherlands | Puerto Rico | Singapore | Switzerland | United Kingdom | West Indies |

New Computers, Boards, Languages, and Other Tidbits

What may be a revolutionary medical program highlights this month's potpourri

by Jerry Pournelle

I'm writing a lot of this on my Otrona in a San Jose hotel room. I don't quite know where the month of June went. Actually, I do: two speeches, a convention, and a lot of work on my novel. Make that three speeches.

Fortunately, there's a lot to write about. Of course, when you're writing about the micro business, there's *always* a lot to write about.

For example: Modula-2/86 is here. The version I have just now runs on the IBM PC under CP/M-86; by the time you read this, there should be others. The Logitech version includes source code (in Modula-2, of course) for KEYBOARD.MOD and DISPLAY.MOD, which are the modules that define the keyboards and display; by fooling about with them, you can make Modula-2 work with a number of PC work-alikes.

You can be sure I'll have more to say about Modula-2.

Something Really Wonderful

I like to give speeches. Most writers do, and as a former professor I often miss my classroom. I simply don't have the time to do it as often as I would like.

I particularly like to give speeches at conferences because I get to meet the other speakers and I learn things it might take me years to discover otherwise. That happened not long

ago at a physicians' conference in Vail, Colorado: I saw a real vision of the future of the micro.

I was supposed to speak at 0900, an hour I don't much care for. Physicians apparently are much earlier risers than I, for they were supposed to have a speaker at 0830. She was sensible, though, and presumed it a misprint, so they didn't have anyone at that ghastly hour. Rather than waste their time, they invited the next day's speaker to begin. He turned out to be Dr. Lawrence Weed, and he hadn't finished when I arrived. I thus discovered by accident the most exciting computer program I've seen this year.

The official name is Problem-Knowledge Coupler. I'd be more likely to call it "Diagnosis by Computer" or an "Auto-Doc." The interesting thing is that the night before I was discussing the possibility that "some-day" there would be computer programs to assist in diagnosis, and several physicians and I agreed that day would not come soon.

We were wrong. The Problem-Knowledge Coupler (PKC) is here right now. Dr. Weed demonstrated it to a fascinated group of physicians. Although most were pleased to see it, one medical student was terrified. "What is there for us to do if the machines can do it all?" he asked.

Of course, the PKC doesn't "do it

all," but it sure does a lot.

It is common knowledge that a patient's medical record is the single most important diagnostic tool available to a physician. A case history plus a good description of symptoms are vital to meaningful understanding. The PKC makes use of this.

A PKC is, of course, a computer program. The patient enters as much of his case history and symptoms as possible in response to a series of questions asked by the program. I'm told this can be done as a dialogue between patient and machine, but I'm sure it's a lot smoother if mediated by a medical professional, such as an office nurse.

Other information, such as blood pressure, pulse, and the like, can be entered by the nurse or the physician. When it's all done, the program offers a list of possible causes.

Note that the machine hasn't "made a diagnosis." It doesn't even present a weighted list; it merely gives all it knows about what could have caused the patient's problems. The physician is free to use intuition, leap to conclusions, order further tests, or do anything else that seems indicated.

It's possible that the physician knows of causes that the machine hasn't listed, in which case the program should be updated. According to Larry Weed, however, that's not

the typical situation.

Consider: we're dealing with a lot of symptoms and indicators. Age, weight, sex, presence or absence of facial hair, blood pressure, somatic type, hereditary factors, diet, previous operations—all these can be important. According to Dr. Weed, a physician generally has to think about as many as 40 indicators. Meanwhile, dozens of possible causes may exist, all linked to the various symptoms in highly complex ways.

Medical diagnosis approaches fundamental limits to human capabilities. Weed demonstrated this by giving the audience a list of symptoms and asking for possible diagnoses. The conference, with more than 40 physicians, could come up with no more than a dozen possibilities; the computer program knew of 28.

Clearly, a physician plus Problem-Knowledge Coupler will be more effective than the physician alone, and the more obscure the problem, the more likely this is to be true.

What really astounded me is that the program runs on microcomputers. Dr. Weed has versions for CP/M 2.2 on the North Star Advantage and the IBM PC. It should be easily adaptable to other CP/M systems.

Aye, There's the Rub

Now comes the disclaimer. I am not a physician. My doctorates are in other fields entirely. Clearly, then, I am not competent to evaluate the medical effectiveness of Larry Weed's computer programs.

The programs are certainly easy to use. They seem to run without glitches. I say "seem to" only because I've yet to do any exhaustive testing, although I intend to.

I spent a lot of time with Larry Weed, including taking part in a dialogue discussion with the entire group, and I was much impressed. Weed has solid academic and medical credentials. He's also fond of pointing out that major league baseball teams and professional

opera companies do not make use of credentials when hiring talent. Performance organizations want to see what recruits can do, not what they've been taught.

Weed wants his PKC judged on that basis—and of course I can't do it. I haven't the credentials. I can only offer observations.

I've seen the program work with test cases. I've watched it list out probable diagnoses, each accompanied by a reference to a medical text. I've seen it list everything a room full of physicians thought of, then add some they hadn't considered but which when put to them were pronounced both reasonable and possible.

I haven't seen it "verified," nor can I think of a way the program could be verified. In particular, there's obviously no way to be certain that the program will list every possible cause of a particular patient's difficulties. I do think, though, that the program could be of great value to physicians.

My view isn't universal. Some physicians I've spoken with are horrified, and a few have said the programs are "demeaning." I fail to understand why. No one thinks checklists are demeaning; how is it different when the checklist is put on a machine? No one thinks reference libraries are demeaning, and everyone insists that reference books have indexes. The PKC looks to me like a very good index.

In any event, I found the programs fascinating, and I'll have more on the subject in a later column. Meanwhile, I'd appreciate comments from those with medical qualifications.

Kaypro versus Osborne

When I give talks, there's one question I get fairly often: which do I recommend, Kaypro or Osborne? As with most questions, the answer is, "It depends." They're both good machines. When the Kaypro first came out, the Osborne software package was clearly superior to the Kaypro's; that's no longer true. The Kaypro 4 (which is in essence the original Kaypro II with double-sided disks) comes with an excellent selection of software.

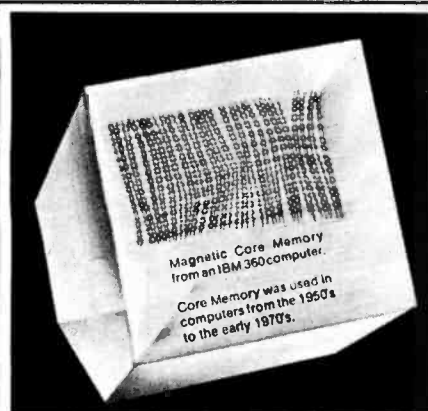

MEMORY BLOCK

Clear Lucite™ cube containing a fragment of history... ideal for paperweight or interesting exhibit. Contains magnetic core memory from an IBM 360 Computer (circa: late '50's-early '70's). Size 2"x2"x2 1/2". 10 day money-back guarantee if not completely satisfied. \$14.95

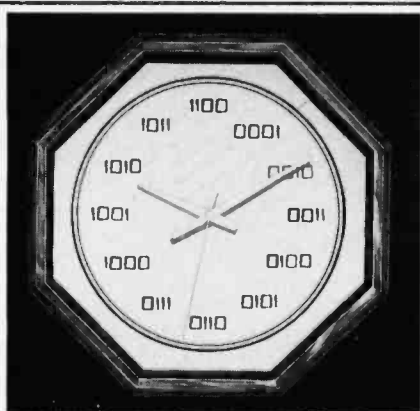

TIMESHARE

Only you and your fellow programmers will know what time it is with this binary numeral wall clock. Handsome simulated dark walnut finish, accurate quartz movement with sweep second hand. Perfect for office or home. Runs on one AA battery. (not incl). 11 1/4" diagonal. 1 yr. warranty. 10 day money-back \$39.95 guarantee if not completely satisfied.

Call Toll-Free Mon.-Fri. 9am-6pm 1-800-B-E-S-W-E-E-T except Florida, or mail coupon below.

BY103

sweet gum inc.

15490 NW 7th Ave., Miami, FL 33169

Please send me ___ Memory Block(s) @ \$14.95
Add \$2 ea. for ship. & handl.

Please send me ___ Timeshare clock(s) @ \$39.95
Add \$3.50 ea. for ship. & handl.

Fla. residents add 5% sales tax. Total \$ _____

Encl. is Check MO Charge my MasterCard Visa
Credit Card # _____ Exp. Date _____

Just send your free COMPUTERMANIA Catalog for now.

Signature _____

Name _____

Address _____

City _____ State _____ Zip _____

600 XL .. \$199.00
 800 XL... \$CALL\$
 1200 XL. \$499.00
 1400 XL. \$CALL\$
 1450 XL. \$CALL\$
 1025 Printer \$399.00
 1020 Color Printer . \$245.00
 1027 Printer \$299.00

EASTERN HOUSE
 Monkey Wrench 2 \$52.75
PARKER BROTHERS
 Tutankham R. \$33.75
 Super Cobra R \$33.75
 Astro Chase R. \$33.75
 Frogger R \$33.75
 QBert R \$33.75
 Popeye R \$33.75
 Risk R \$42.75
 Chess R \$42.75

MODEMS
 ANCHOR MARK I .. \$79.00
 ANCHOR MARK II. \$79.00
 HAYES SMART .. \$239.00
 HAYES MICRO II \$309.00
 Micro Bit
 MPP-1000 \$159.00
 NOVATION
 CAT \$144.00
 D-CAT \$155.00
 J-CAT \$115.00
 APPLE CAT II .. \$279.00
 212 APPLE CAT .. \$589.00

RANA
DISK DRIVE
 1000 \$call
ALIEN GROUP
 Voice Box 2 . \$99.75
DON'T ASK
 Sam \$41.75
 Abuse \$15.95
 Teleatrl \$27.95
 Poker Sam \$24.95



800 48K \$199.00*
 * after \$100. rebate from ATARI cash price \$299.
810 Disk \$399.00

BRODERBUND
 Bank Street Writer D. \$44.75
 AF D. \$24.75
 Apple Panic D. \$23.75
 Choplifter ROM \$32.75

1010 Recorder \$75.00
 410 Recorder \$75.00
 810 Disk Drive \$399.00
 1050 Disk Drive \$335.00
 850 Interface \$CALL\$

Lyc0 Computer Marketing & Consultants

TO ORDER CALL US TOLL FREE 800-233-8760
 In PA 1-717-

BLANK DISK
 ELEPHANT SS/SD \$18.25
 ELEPHANT SS/DD \$21.75
 KANGAROO SS/DD with
 storage case \$24.75
 MAXELL MD I \$29.75
 MAXELL MD II \$39.75
 DISK CASE (holds 10) \$4.95
 DISK CASE (holds 50) \$19.75
 ROM CASE (holds 10) \$19.75

MONITORS
 Amdek Color I \$275.00
 Amdek 300 Green \$149.00
 Amdek 300 Amber \$149.00
 Gorilla Green \$99.00



SINGLE DRIVE AT88 S1 ... \$359.00
DUAL DRIVE AT88 S2 \$559.00
 DRIVE with printer port ... \$449.00
AT88 Expansion Board \$139.00
DUAL HEAD 44S1 \$575.00
SINGLE DRIVE 40S1 \$529.00
ADD ON DRIVES \$CALL
HARD DISK DRIVES \$CALL\$

RANA DISK DRIVES
 Elite 1 \$295.00
 Elite 2 \$449.00
 Elite 3 \$559.00
SSI
 Battle of Shilo \$26.75
 Tigers in the Snow \$26.75
 Cosmic Balance \$26.75
 Knights of the Desert. \$26.75
 Battle for Normandy.. \$26.75
 Germany 1985 \$36.75
CONTINENTAL
 Home Accountant \$51.75
 Book of Apple Software . \$16.75



APPLE DUMPLING GX \$99.75
 APPLE DUMPLING 64 (16 Buffer) \$179.75
INFOCOM
 Zork I, II, or III \$26.75
 Deadline \$33.75

SANYO
 MBC 1000 \$1549.00
 (with micropro software package)
 MBC 1250 \$2195.00
 MBC4050 \$2749.00
 EFD 160 Disk \$499.00
 5500 Letter Q. Printer... \$649.00

HES 64
 Turtle Graphics R \$49.75
 Heswriter R \$38.75
 Attack of Mut Cam R... \$34.75
 Turtle Tutor R \$29.75
 Turtle Trainer R \$29.75
 Paint Brush R \$23.75
 Benji Space Rescue D. \$29.75
 Home Manager C/D ... \$39.75

CARDCO
 Cardprinter / LQ1 \$499.00
 Cardprint DM1 \$109.00
 5 Slot Expansion 64 \$54.00
 64 Write NOW \$39.00
 64 Mail NOW \$29.00
 20 Write NOW \$29.00
 64 Keypad \$29.00
 Universal Cass. Int. \$29.75
 Printer Utility \$19.75
 6 Slot Expansion \$79.95
 3 Slot Expansion \$24.95
 Vic 20/64 Printer Int ... \$59.95
SPINNAKER 64
 Kindercomp \$21.75
 Story Machine \$23.75
 Face Maker \$23.75
 Snooper Trooper \$29.75
 Delta Drawing \$34.75

commodore
HES VIC 20
 Torg C \$14.75
 HES Games I C \$14.75
 HES Games II C \$14.75
 VIC Fortit Rom \$42.75
 HES MON Rom \$28.75
 Turtle Graphics Rom \$28.75
 HES Writer Rom \$28.75
 Shamus Rom \$28.75
 Protector Rom \$31.75
 Robot Panic Rom \$28.75
BRODERBUND 64
 Serpentine R \$26.75
 Choplifter R \$32.75
 Seafox R \$26.75
PARKER 20
 Frogger (ROM) \$33.75
 QBert (ROM) \$33.75
 Tutankham (rom) \$33.75

**PRINTER
 RIBBONS
 AVAILABLE**

PROWRITER 2P. \$699.00
GEMINI 15 \$449.00
PRINTMASTER \$1589.00
SMITHCORONA TP1... \$549.00
 CITHO 8600B \$1025.00
 STARWRITER \$1099.00
 OKIDATA 82 SAVE
 OKIDATA 83 LOWEST
 OKIDATA 84P PRICE
 OKIDATA 93 AVAILABLE
 TRACTOR \$49.75
 OKIDATA 92 \$SAVE

SAVE on these in-stock PRINTERS

GORILLA GX-100 \$199.00
EPSON \$CALL
GEMINI 10 \$299.00
PROWRITER \$365.00
NEC 8023 \$399.00

MasterCard **TO ORDER** **VISA**
 CALL TOLL FREE **800-233-8760**
 In PA 1-717-327-1824
 or send order to
 Lyc0 Computer
 P.O. Box 5088
 Jersey Shore, PA 17740

POLICY
 In-stock items shipped within 24 hours of order. Personal checks require four weeks clearance before shipping. No deposit on C.O.D. orders. Free shipping on prepaid cash orders within the continental U.S. PA residents add sales tax. All products subject to availability and price change. Advertised prices show 4% discount offered for cash, add 4% for MasterCard or Visa. DEALER INQUIRIES INVITED.

DIAMOND DELIVERS!

FREE Dust Cover With Every Order

Multitool Word \$269 Infostar \$259
 Wordstar \$245 dBase II \$ call
 Visicalc \$169 Supercalc 2 \$169

	LIST	OUR PRICE		LIST	OUR PRICE
Micropro®	\$250	\$135	Visicorp®	\$250	\$169
MAILMERGE	\$250	\$135	VISICALC	\$375	\$289
SPELLSTAR	\$645	\$339	VISIWORD	\$300	\$199
WORDSTAR/MAILMERGE	\$350	\$219	VISIFILE	\$300	\$205
REPORTSTAR	\$195	\$ 99	VISITREND/PLOT	\$300	\$205
CALCSTAR			VISISCHEDULE	\$300	
Sorcim®	\$195	\$129	Condor®	\$650	\$429
SUPERCALC	\$295	\$169	CONDOR 20-3	\$295	\$199
SUPERWRITER	\$295	\$169	Fox & Geller®	\$ 99	\$ 65
Ashton-Tate®	\$700	\$309	QUICKCODE	\$295	\$199
dBASE-II	\$400	\$199	dUTL		
THE STRATEGIST	\$295		dGRAPH	\$150	\$ 99
FRIDAY	\$425	\$329	Continental®	\$350	\$259
Supersoft®	\$500	\$359	HOME ACCOUNTANT PLUS	\$400	\$295
FORTRAN	\$295	\$225	Digital Research®	\$200	\$145
C COMPILER			CONCURRENT CP/M 86	\$200	\$155
SCRATCHPAD	\$495	\$239	PASCAL MT+ 86	\$200	\$359
Lexisoft®	\$345	\$249	C BASIC 86	\$500	\$215
SPELLBINDER	\$275	\$175	SPP	\$300	\$279
Microsoft®	\$695	\$479	PASCAL MT+ W/SPP	\$400	\$ 99
SOFTCARD	\$495	\$345	ACCESS MANAGER	\$150	\$ 99
MULTIPLAN	\$100	\$ 69	DISPLAY MANAGER	\$500	\$359
PREMIUM SYSTEM	\$150	\$109	C BASIC	\$ 60	\$ 44
MULTITOOL WORD	\$350	\$259	CB 80		
W/MOUSE	\$350	\$259	CP/M 86	\$680	\$499
MULTITOOL FINANCIAL	\$350	\$259	Quadram®	\$295	\$229
MULTITOOL BUDGET	\$500	\$349	QUADLINK	\$395	\$289
PASCAL	\$350	\$269	QUADCOLOR	\$595	\$425
FORTRAN	\$350	\$289	64K EXPANDABLE BOARD	\$195	\$135
C COMPILER	\$395		256K		
BASIC 80			Microstuf®	\$395	\$319
BASIC COMPILER	\$299	\$219	CROSSTALK	\$195	\$129
Software Arts®	\$100	\$ 85	Computer Innovations®		
TK SOLVER			C COMPILER		
FINANCIAL MANAGEMENT			Lifetree®		
			VOLKSWRITER		

At Diamond Software we offer the best selling business application software for your IBM PC, CP/M or Apple Computer at the lowest possible prices. And we maintain a complete technical department to assist you before, during and after your system purchase. Not only that, we offer same day shipment on most items and we accept Visa, Mastercard and also American Express. We'll even pay the shipping charges if you send us a money order, cashiers, company or personal check. Purchase orders are gladly accepted from qualified organizations and we welcome dealer inquiries. Call Diamond today, you'll be glad you did.

TO ORDER CALL TOLL-FREE 1-800-227-0545

Diamond Software Supply 484 Lake Park Ave., Suite 123 • Oakland, CA 94610

For price quotes, information, or in California call 1-415-893-7676. We credit your order for the call. Technical Department (415) 893-7678. International Telex 338139 (attn. 149)

Support, Service and Price.

Shipping/Handling UPS surface \$3.00 plus an additional \$3.00 per item for UPS Blue. C.O.D. orders add \$4.00. For personal check allow 2 weeks for delivery. All items subject to availability. prices subject to change without notice. Calif. residents please add 6% sales tax. ® IBM is a registered trademark of International Business Machines. CP/M is a registered trademark of Digital Research.

On the other hand, the Osborne Executive comes with much introductory material and a powerful software package, plus the possibility of updates to compatibility with the IBM PC, an option the Kaypro doesn't have. Osborne also has a widespread network of dealers and service centers; more than Kaypro as of this writing. That, too, is subject to change and could be different by the time you read this.

I have experience with both machines: I had a very early copy of both the Osborne 1 and the Kaypro II. Each had its problems, but all those difficulties were fixable. The early Kaypro II had some software problems that caused excessive disk wear. The early Osborne 1 had other troubles, particularly with the keyboards. In both cases the problems have been revised out of the later-production machines. I still have my old Osborne 1, and it does yeoman service as a loan-out machine; Barry Workman ended up buying (from Kaypro Corporation) my old Kaypro II. He has a special program that lets it read a wide selection of disk formats, and it has become a workhorse for his operation. Neither machine has required what I'd call excessive maintenance. They've both had their out-of-service periods, but nothing I wouldn't expect given their hard usage.

Thus, I have no trouble recommending either the Osborne 1 or Kaypro II as a first machine for someone with a low budget. Neither would be my first choice if I could afford more, but both are more than adequate as word processors and general-purpose computers for writers and small-business owners.

By the time you read this, however, you may not be able to find an Osborne 1; they don't make them anymore. They recently dropped the price to \$1295, and while they last, that's a pretty good deal. Some do appear on the used market. I've never advised anyone to buy a used computer. Given that this computer no longer exists, there's not a lot of competition down at the low end of the "transportable" professional computer price scale.

THE EASY CHOICE



Best Separate Compilation – Best Error Handling – Best Implementation on a Small Computer
Comments From 1983 LA AdaTEC Compiler Faire

"... JANUS/Ada encompasses at least 5 times as much of Ada as Supersoft, including many of the more exotic features of the language." *Creative Computing*

"... The compiler performed exceptionally well... the linker performs flawlessly... the error handling is excellent... RR's support is the best I've ever encountered." *InfoWorld*

"The compiler breaks new ground in the microcomputer field with its excellent runtime error-checking code and its excellent compiler error messages." *Microsystems*

"They're (RRS) honest to a fault, so they call their language JANUS; but its more nearly Ada than any other microcomputer implementation I know of... I watched some of the demonstrations and it works." *Jerry Pournelle, Byte*

Encouragement of this kind deserves a just reward; we now intend to complete our compiler and submit it for validation.

Our Ada line is available on the following operating systems: CP/M, CP/M-86, MS-DOS, PC-DOS and CCP/M-86

Available from the following distributors:

Westico, Inc.
 25 Van Zant, St.
 Norwalk, CT 06855
 (203) 853-9880

Marfam Corporation
 5340 Thornwood Dr. Suite 102
 San Jose, CA 95123
 (408) 226-0170

Suntex Data
 10175 Harwin Suite 100
 Houston, TX 77036
 (713) 271-9191

S-100 Systems
 3687-4 Shobumachi
 Obayashi
 Saitama, Japan 346-01
 04808 (5)0416:
 04808(5)6565

Micronix
 11 Blackmore St.
 Windsor 4030
 QLD. Australia
 (07)57 9152

Nord-Micro Informatique
 155, rue du Fauburg St.
 Denis
 75010 Paris
 (1)205-39-47

CP, M, CP, M-86, CCP, M-86 are trademarks of Digital Research, Inc.
 *ADA is a trademark of the U.S. Department of Defense
 MS-DOS is a trademark of Microsoft

© Copyright 1983 RR Software

RR SOFTWARE, INC.

specialist in state of the art programming

P.O. Box 1512 Madison, Wisconsin 53701

(608) 244-6436

Circle 393 on inquiry card.

BYTE October 1983 111

Kaypro 4 versus Osborne Executive

Either the Kaypro or the Osborne is satisfactory as a first computer. They're both competitive with anything else in their price range. My experiences with them are a bit limited, but so far neither has given me any trouble, and both are notable improvements over the earlier models—so much so that I urge anyone contemplating a first machine to try to spring for the extra bucks to get the Executive or Kaypro 4 rather than the Osborne 1 or Kaypro II.

The Executive has true composite video output: you can plug it direct-

ly into a monitor (but not a TV). If you want to use the Executive to drive a TV set for demonstrations or simply because you want a larger screen, you'll need an RF modulator. The Kaypro machines do not have any external video output. On the other hand, the screens for both the Executive and the Kaypro machines are adequate, although if I were doing a lot of work with either, I'd want something bigger.

The Executive has a *much* nicer screen, and the character set is more pleasing. These are matters of taste, of course, and not everyone would agree with me.

Neither the Osborne Executive nor

the Kaypro can be described as portable. "Transportable," yes; but not portable. Both weigh the same: too much (about 28 pounds stripped). I already have arms like an orangutan from carrying the Otrona Attache. (That machine weighs only 18 pounds, but with disks, power cord, documents, and shoulder-strap carrying case the entire mess comes to about 25 pounds; I'd be smarter to put most of the documents in my checked luggage.) Alex and I have carried both Osborne and Kaypro machines all across the country; you *can* do it, if you have to, although you won't enjoy it.

The Executive has single-sided

INTRODUCING The first software program

Sign-Master is an exciting new program that for the first time lets you *transform* ordinary-looking presentations, proposals and special reports into dynamic, colorful word charts. Before Sign-Master, it required a

graphic artist or dedicated graphics processor to create impressive word charts, both time-consuming and more costly options. Now, with Sign-Master's amazing flexibility, you can produce presentation-quality word

charts on paper or acetate in six different type styles and in 16 different sizes — a real breakthrough when you consider that over 65% of all presentations consist of word-only formats. (When graphs are indicated to

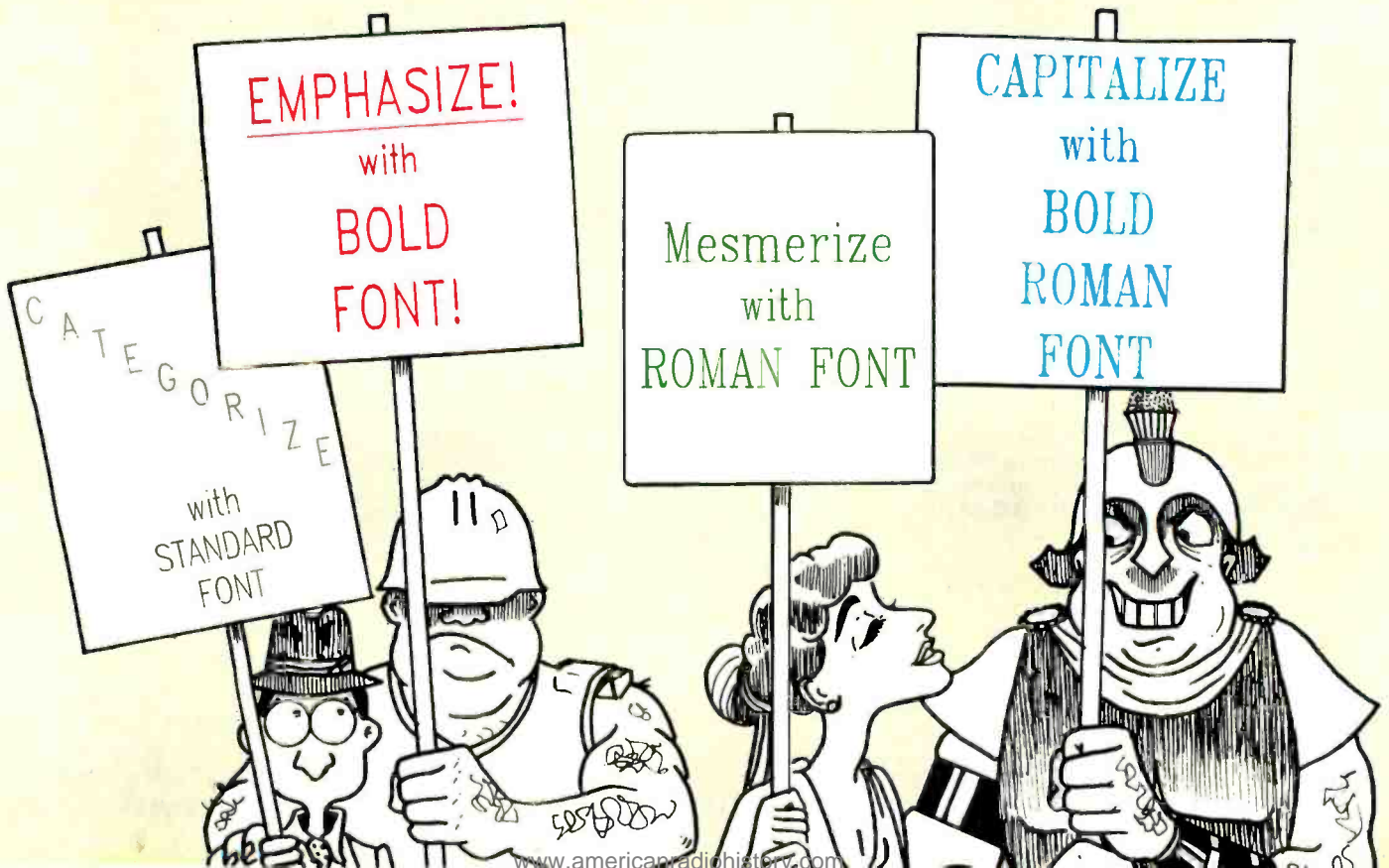

double-density disks (180K bytes per disk); the Kaypro 4 has full double-sided disks, for a full 380K bytes on each. This is probably the most significant hardware difference between the two.

The Executive has two serial output ports and one parallel port that can be either IEEE-488 or Centronics (printer) compatible. Kaypro machines have one serial port and one Centronics port.

The real difference between the machines shows up in packaging and software. The Kaypro was designed by engineers and looks it. Alas, so were most of the Kaypro documents. The latest ones are a *vast* improve-

ment over the ones that came with the first machines, but they still assume you're willing to learn a good bit about CP/M and that you *want* to know things about your computer. Example: whenever your Kaypro does a warm boot, it tells you so by printing the words "warm boot" on the screen. Users not familiar with CP/M react to this in various ways, some of which can be ribald.

The Osborne "philosophy" is that most computer users know little and care less about the way computers work; Adam Osborne would rather commit seppuku with a printed-circuit board than gratuitously tell his users that the machine has done a

"warm boot." The Executive runs vanilla CP/M+ (3.0). The Osborne documents assume you don't know what that is and go from there. (When you turn the machine on with a Wordstar disk in it, the Osborne assumes you want to run Wordstar and brings that up; you never see CP/M unless you want to.)

Osborne's software package includes a number of industry standards, such as Supercalc and, of course, Wordstar. There's also Microsoft MBASIC, Digital's CBASIC, and a run-time disk that will let you run programs written in UCSD Pascal (but not write them; you'd have to buy that separately). Also included

SIGN-MASTER!™ to bring word charts to life!

highlight your data, ideas and conclusions, our Chart-Master™ graphics software is available to do the job.)

Sign-Master can also be used to create effective instruction materials, bulletin board an-

nouncements and direct mail pieces that demand attention. To generate real impact, Sign-Master word charts can be as colorful as you like, depending on the plotter you use. *And* you can be as creative as you like by capital-

izing or italicizing a single character, a single word, or an entire line at the touch of a button. In addition, margins can be justified left, right or centered.

Best of all, Sign-Master's on-line instructions, power and variety of options make you a "Sign Master" without special training.

Sign-Master — the first software program that brings word charts to life.

Sign-Master supports a wide variety of plotters from IBM, Panasonic, Hewlett-Packard, Houston Instruments, Yokogawa, Strobe, Amdek and many others, for use with IBM PC, PCXT and other compatible computers.

The retail price of Sign-Master is \$245.00. For a complete information kit and name of your nearest dealer, contact:

Decision Resources, Inc.
25 Sylvan Road S.
Westport, CT 06880
(203) 222-1974.

Sign-Master and Chart-Master are trademarks of Decision Resources, Inc.

Circle 143 on inquiry card.

DecisionResources, Inc.
Software Designed for Decision Makers



8-MHz 8087. Intel, which makes the chip, was kind enough to supply one for my system. Hudson's board is designed to let you update by simply snipping off two small pins (it's explained fully in Hudson's documents); that will put your 8088 back up to 8 MHz after you get the faster 8087 chip. Intel's people say they'll be able to supply 8-MHz 8087 chips in quantity toward the end of 1983, possibly by the time you read this.

We put the 8-MHz 8087 in my system and speeded the 8088 back up to 8 MHz. The speed improvement is noticeable. There's also an improvement in disk operation speeds even when running 8-bit software with the 8085. My engineer friends tell me that's impossible. All I can say is that it seems faster.

There's not a lot of software that can make use of the 8087, but there's more than I would have supposed. Digital Research supplies 8087 packages with both Pascal MT+/86 and its C86 compilers. In addition, Digital's ASM86 assembler comes with 8087.LIB, a package of 8087 support routines. Supersoft advertises a FORTRAN 86 with 8087 support capability. Logitech's Modula-2 will have 8087 support modules.

Finally, Jim Hudson's piggyback 8087 board normally has no effect on the 8085 (8-bit) half of a dual processor, but there can be exceptions, as with Jack Hersh's FORTRAN 80-87 software reviewed below.

As I was writing this, Jim Hudson called to say that he has a version of the 8087 board for the NEC Personal Computer, and he expects to have one for the Zenith Z-100 by the time this is published. If you crunch numbers, this is a must.

Speed, Precision . . .

The 8087, and especially the 8-MHz 8087, will have a larger impact on the micro community than you might think.

Because 8-bit machines are so very slow in operations involving high-precision numbers, a great deal of the 8-bit software has been written to use only single precision. The 8087 isn't particularly efficient at single-precision calculations, so for much soft-

Program	8-MHz 8087	5-MHz 8087	8-MHz processor (no 8087)	5-MHz processor
Test n=32,000	6.55 sec.	9.87 sec.	3 min., 53 sec.	6 min., 12 sec.
Mat20X	4.44 sec.	7.24 sec.	1 min., 11.96 sec.	1 min., 51 sec.
Mat50x	1 min., 3.5 sec.	1 min., 41 sec.	17 min., 52 sec.	27 min., 38.7 sec.

Table 1: Benchmark tests for the 8087 Systems Support Board.

is Personal Pearl—six disks' worth. Pearl is a "program writing program"; in practice that means you can write file-manager programs with it. If you work at it, you can write some pretty sophisticated stuff.

The Kaypro package is interesting. You have a choice of Perfect Writer or Wordstar; either way you get Wayne Holder's The Word Plus, the best spelling program I know of. The Perfect package includes Perfect Writer, Speller, Filer, and Calc. There's also Chang Lab's Profitplan, a spreadsheet something like Perfectcalc. It's not as good as Supercalc. The package now includes MBASIC and an off-brand BASIC called SBASIC (which is something like CBASIC in both speed and program structure).

In other words, the software packages are comparable. The real difference between Kaypro and Osborne is philosophical. If computers scare you but you can't live without them, Osborne is clearly the better way to go. If you're willing to live with ambiguities and you're curious about small computers, the Kaypro may be more appealing.

They're both good machines.

That's Fast!

Jim Hudson has revised his 8087 math board; it now plugs directly into a Compupro 8085/8088 Dual Processor without modifications to the Compupro board. The board was reworked by Compupro, then redone again by Hudson, who tends to be something of a perfectionist.

The problem with the 8087 "math cruncher" chip is that it runs at 5

MHz (or 5 million cycles per second). That's somewhat slower than the 8 MHz of the 8088 processor ("brain") chip; the result is that if you want the extra math processing speed of the 8087, you have to slow the whole system down. This used to require modifications to the 8085/8088 processor board. Hudson's new board takes care of it without those modifications.

To install Hudson's math board, you must remove the 8088 chip from your processor, plug his board in where your chip used to be, and plug your chip into the empty socket on his board. Two pins on his board interact with the original Compupro processor board to slow it down without your having to do anything else.

You wouldn't think it would be worth the effort to slow your system down, but if you have many calculations to make, it's not only worthwhile, it's necessary. The speed improvements are shown in table 1. Two benchmark tests are included in this table: 32,000 mathematical operations (program Test) and the matrix filling and multiplication "benchmark of sorts" I first described in my October 1982 BYTE column. As you expect, "Mat20x" fills and multiplies 20 by 20 matrices; the "Mat50x" times are for 50 by 50 matrices.

As you can see, adding the 8087 makes for dramatic speed improvements, even though you've slowed the whole system from 8 MHz to 5 MHz. For the past six months, I've run my system at the slower speed in order to take advantage of the 8087.

It's even nicer if you can get an



In a race between 200 cps printers, Anadex outran Okidata Two to One.*

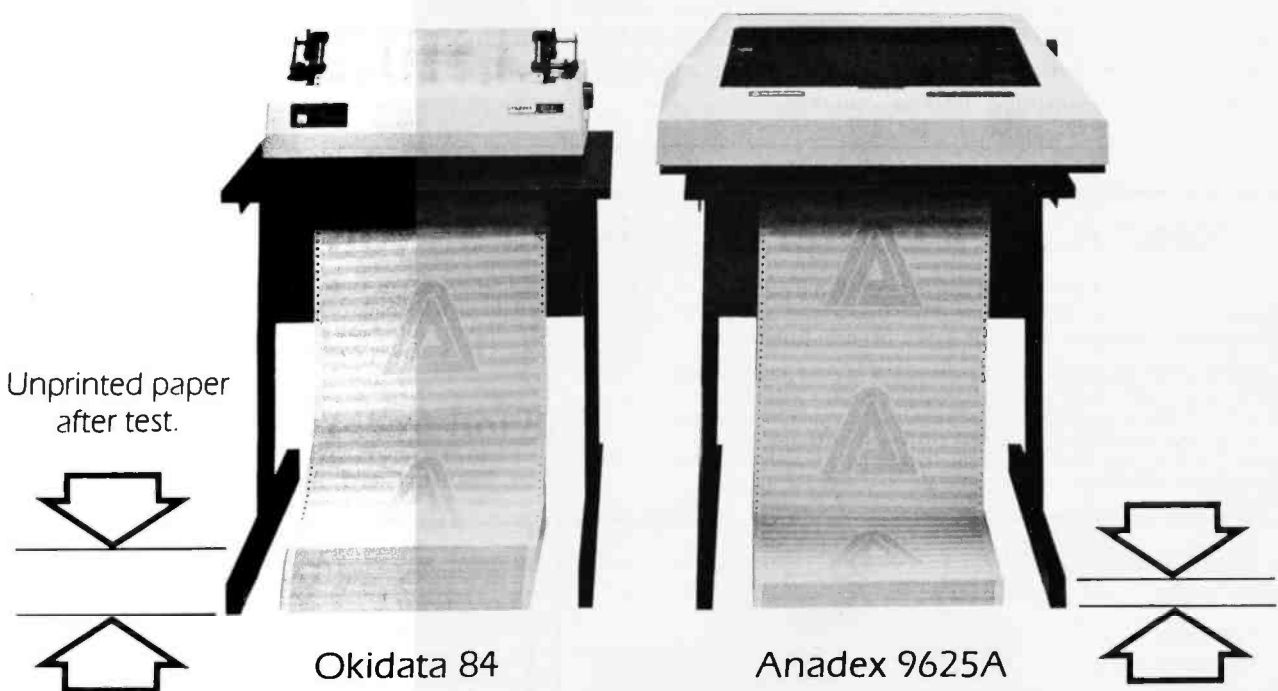

*For a copy of the independent test lab report,
Call (800) 792-7779. In California Call (800) 792-9992.

Anadex. Nobody else comes close.

©Copyright 1983 Anadex, Inc.

ANADEX, INC. • 9825 De Soto Avenue • Chatsworth, California 91311, U.S.A. • Telephone: (213) 998-8010 • TWX 910-494-2761
U.S. Sales Offices: San Jose, CA (408) 247-3933 • Irvine, CA (714) 557-0457 • Schiller Park, IL (312) 671-1717 • Wakefield, MA (617) 245-9160
Hauppauge, New York, Phone: (516) 435-0222 • Atlanta, Georgia, Phone: (404) 255-8006 • Austin, Texas, Phone: (512) 327-5250
ANADEX, LTD. • Weaver House, Station Road • Hook, Basingstoke, Hants RG27 9JY, England • Tel: Hook (025672) 3401 • Telex: 858762 ANADEX G
ANADEX GmbH • Behringstrasse 5 • 8752 Mainaschaff • Frankfurt, W. Germany • Tel: 011-49-06021-7225 • Telex: 4188347

Circle 35 on inquiry card.

BYTE October 1983 115

ware written for, say, the Z80, there's only a gain of a factor of 3 to 4 if you put an 8087 in the loop.

If you use double precision, there's a gain of perhaps 500.

Thus, older micro programs may not be much improved, but if you want double precision (or greater) from a micro, there's a way to do it, provided you can work in FORTRAN. While I was at Jim Hudson's house, Jack Hersh came in.

People in the micro world tend to have nonmicro origins. Jim Hudson, for example, was an anthropology major in college and ended up working for Intel through a chain of coincidences. Similarly, Jack Hersh started off to be a philosopher but has become a computer whiz. He markets his stuff under the name Avant-Code.

Hersh has written a series of library modules for Microsoft's FORTRAN F-80. You write a normal double-precision program in FORTRAN and link in his modules with Microsoft's L-80 linker (which is supplied with its

FORTRAN).

Of course, that won't work on just any system. You need a Compupro Dual Processor with Jim Hudson's 8087 board attached. In addition, you must have the Compupro Systems Support Board, and you must run the system under the Compupro standard CBIOS (customized basic input/output system). Hersh's program runs fine with M-Drive/H pseudo disks, but it won't work with the earlier M-Drive or Warp Drive system.

What's happening, of course, is that although FORTRAN F-80 uses only the 8085 part of a Compupro Dual Processor Board, Hersh's routines wake up the normally dormant 8088 chip and induce it to do the management necessary to coordinate things for the 8087 chip. In order to do that, you need some extra memory. There's a slot for that memory on the Compupro Systems Support Board; Hersh supplies the memory chip to plug into the usually empty socket.

It all sounds complex, but in practice it's easy enough to install and use, and if you have a lot of double-precision numbers to crunch and must use 8-bit software, it's worth looking into.

Jazz Up Your Z-19

The Heath/Zenith Z-19 is a good terminal but has some problems. For one thing, if you try to run it at a really high speed—say at 19,200 bps—it drops characters and otherwise gives me trouble.

Some time ago I was sent a simple fix for that. The Super-19 from Extended Technology Systems does the job nicely. For 50 bucks you get a new ROM (read-only memory) chip and some instructions on how to install it. The whole job, including figuring out how to remove the cover from the Z-19 if you've never done it before, takes no more than 10 minutes for a slow worker.

The documents say that you can run the Z-19 at 38.4 kbps, but ours wouldn't run that fast. It goes at 19.2

New! A work center as efficient as your computer

At last! Computer furniture in warm traditional styling, designed to be used in the home. Finished in antique (dark) pine. Kits come ready for assembly and finishing.

1. The Deerfield Computer Desk. Quality built of solid pine with the features you need for your personal computer system: a 44½"l x 13½"d CRT shelf at a comfortable viewing height; two 6"h x 21¼"w x 12¾"d storage compartments for disk-drive and keyboard; and a convenient wire pass-through in back. Overall: 34½"h x 48"w x 30"d. Shipped knocked down.

2. The Rolling Printer Stand. Paper feeds from the big 11¼"h x 24"w x 21¼"d shelf through a middle or back slot into your printer. The drop leaf catches print-outs. Solid pine. Sized to slip beneath the Deerfield Desk. 17"h x 25½"w x 24"d. Knocked down.

Call toll-free: 1-800-258-4720

In New Hampshire: 1-800-552-0320

Visa, MasterCard, American Express

Only \$199.⁹⁵
plus shpg.

- CRT shelf
- Disk-drive and keyboard storage
- Wire pass-through slot



Yield House®

Quality furniture for over 35 years
Dept. BY30 North Conway, N.H. 03860

Please send me the Deerfield Computer Desk
— Finished #320A. \$199.95. Add \$35.00 shipping.
— Kit #320K. \$139.95. Add \$15.00 shipping.

Please send me the Rolling Printer Stand
— Finished #365A. \$139.95. Add \$12.00 shipping.
— Kit #365K. \$99.95. Add \$10.00 shipping.

— Please send me additional free information.

Name (please print)

Address

City

State

Zip

True MAIL ORDER Prices

With so many so-called Mail Order establishments using "toll free" lines, and grandiose advertising, how can you, the customer, expect to receive true mail order savings? We have done away with these expenses to offer comparable service passing on the savings to you. Our reputation for low prices and satisfaction is outstanding.

DISKETTES		PRINTERS		MONITORS	
*Kangaroo: (w/library case) 5 1/4" SS/DD \$21.35 5 1/4" DS/DD \$28.95 Now available: The 6-pak! 5 1/4" SS/DD \$14.45 5 1/4" DS/DD \$19.45 — 10 yr. Warranty, —		OKIDATA: Microline 92 \$ 499.00 Microline 93 \$ 869.00 Juki Printer: • L/Q • 18CPS \$CALL C.ITOH: Prowriter I Parallel \$ 369.00 Prowriter I Serial \$ 489.00 Prowriter II Parallel \$ 629.00 Prowriter II Serial \$ 689.00 F-10 Starwriter \$1150.00 F-10 Printmaster \$CALL Brother HRI: \$ 775.00 Smith Corona TPI: \$ 539.00 Star Micronics: Gemini 10X Call for low prices! Gemini 15 \$CALL		Amdek: Color I \$295.00 Color II \$489.00 300G Green \$145.00 300A Amber \$155.00 310A Amber \$175.00 Zenith: 12" Green \$ 99.00 USI: 12" Amber \$159.00 12" Green \$155.00 *Taxan: Amber \$139.00 PGS: RGB Monitor \$ CALL BMC: 12" Green \$ 95.00 NEC 1203 Hi Res RGB \$589.00	
MODEMS		SPECIAL		DISK DRIVES	
Hayes: MicroModem II with Terminal Program \$285.00 without Terminal Program \$255.00 Hayes Smartmodem 300 Baud \$199.00 1200 Baud \$505.00 Novation: J-Cat \$104.00 Applecat II \$285.00 Smartcat 1200 Baud \$440.00 U.S. Robotics: 300 Baud \$165.00 1200 Baud \$459.00 Password \$CALL		Columbia Data Products Personal Computer Featuring: • IBM PC Compatibility • 16-bit 8088 Processor • 8 Expansion Slots • Two RS232 Serial Ports • Centronics Printer Port • Double Density Floppy Disk Controller* • 128K RAM Standard Memory \$CALL		For Apple: Fourth Dimension: w/o controller \$219.00 w/ controller \$309.00 Rana Elite I: w/o controller \$270.00 w/ controller \$339.00 For IBM: Shugart Half-Height \$239.00	
COMPUTER PRODUCTS FOR IBM		TANDON DISK DRIVE SPECIAL		COMPUTER PRODUCTS FOR APPLE	
The Ultimate Peripheral MONTE CARLO™ GT™ CARD 64K \$CALL \$45 per 64K upgrade Ask about the Quatro™ Card		TM-100-2 DS/DD 320K Bytes \$235.00 TM-55 320K Bytes Half Height \$235.00		MBI: VIP Graphics Card \$109.00 Appltime Clock Card \$ 75.00 Silicon Valley Systems: Final Analysis \$149.00 Word Handler \$115.00 Continental: Home Acct. \$ 49.00 On-Line: Screenwriter II Pro \$139.00 Visicorp: Visidex \$180.00 Visifiles \$180.00 Visicalc \$180.00 Visitrend/PIot \$225.00 Stoneware: DB Master \$154.00 DB Utility Pak \$ 85.00 T & G Products: Joysticks \$42.00 Select-a-Port \$42.00 Game Paddles \$28.00 Davong Hard Disks 5 Megabytes \$1359.00 10 Megabytes \$1759.00 15 Megabytes \$2159.00 Ram Cards Microsoft 16K \$75.00 Generic 16K \$60.00 Microsoft CP/M Z80 Card \$249.00 80 Column Card: Videx w/softswitch \$269.00	
QuadRam Quadboard 64K \$285.00 128K \$330.00 192K \$375.00 256K \$415.00 Kraft Products: Joysticks \$55.00 Game Paddle \$29.00 Davong Hard Disks 5 Megabyte \$1359.00 10 Megabyte \$1759.00 15 Megabyte \$2159.00 Maynard Electronics Floppy Controllers w/Parallel \$209.00 Floppy Controllers w/Serial \$239.00		Business Visicorp: Visidex \$180.00 Visifiles \$180.00 256K Visicalc \$180.00 Visitrend/PIot \$225.00 ENTERTAINMENT: Infocom: Zork I \$27.00 Zork II \$27.00 Zork III \$27.00		T & G Products: Joysticks \$42.00 Trakball \$49.00	

Send orders and inquiries to:

Computer Apparatus™

P.O. Box 32063 • Aurora, Colorado 80012

Telephone Inquiries: (303) 759-9251

Monday thru Friday — 9:00 a.m. to 5:00 p.m. (Mountain Standard Time)

**We built our reputation on low prices
for the informed computer user.**

DELIVERIES: 2 - 4 weeks average
 PERSONAL CHECKS: Cashier's check and money order will receive shipping preference
 VISA & MASTERCARD: Add 4% to total
 CATALOG: Send for full pricing details
 Prices subject to change without notice
 SHIPPING: UPS add \$2.00 plus 3% of order total, or we calculate exact freight.

without a glitch, though. The Super-19 got a very extended test when Alex took the Z-19 terminal (with the Super-19 in it) off to UCSD (the school, not the system) last fall, and we both forgot to mention it in previous columns. Alex has had this installed as part of Helen (his CCS Z80 system) for months, with no problems, and he says he'd *never* go back to 9600 bps now. Recommended.

A Glitch or Two

The Z-19 with Super-19 won't run at 38.4 kbps for the same reason that you can have trouble running the Heath/Zenith Z-29 terminal at 19.2 kbps. The cables are very sensitive to electrical noise.

In fact, if you want to run the Z-29 at 19.2, you must use the cables supplied with the machine, and don't extend them. Otherwise, the machine can sometimes drop characters. This can have dramatic results depending on the character dropped; leaving things out of a command string is always inconvenient and often disastrous.

It's a good general principle: if you're trying to run things up toward their limits, pay a lot of attention to cables and cable connectors, and keep all the lines as short as possible. This is only common sense, but it's sense that's too often ignored.

As long as you pay attention to the cables, the Z-29 works fine at 19.2, and we still like it a lot.

Slowly but Surely . . .

A recent letter from Canada complains that the Compupro 8086/8087 board doesn't seem to run much faster than a Z80. My correspondent thought this impossible. I put the problem to Tony Pietsch, and tonight I got his report.

Much of the 8086 software, including the BIOS supplied by Compupro, is thinly reworked 8085 (8-bit) stuff. Some was hurriedly translated. The result is fast machines with v-e-r-y s-l-o-w software.

Help is on the way. Tony has begun rewriting all the Compupro BIOSes and is slowly working his way through all the products. He recent-

ly finished a new BIOS for the Dual Processor. I installed it tonight, and it speeds things up something wonderful. By the time you read this, the BIOS I use, including all the friendly little touches like recovering from some CP/M BDOS (basic disk operating system) errors, will be standard with Compupro equipment.

It does point up a problem: if you want the absolutely latest state-of-the-art hardware, you may have to either write your own software or put up with something not so fine for a while. On the other hand, what I think of as "not so good" often turns out to be better than what most people think is "standard," and when you have really high performance hardware, you can be certain that someone will eventually develop software worthy of it.

Sweet Adeline

Alas, poor Adelle, my very low serial number Otrona, is no longer with me. She developed some problems with the disk speed regulator. Under ordinary circumstances, she'd have gone to an Otrona dealer to be fixed. The dealers simply swap out modular parts until the machine works again. This is easy enough because the Otrona is very modular in construction, and a very inexperienced technician can swap assemblies.

However, in my case Otrona tried fixing things under time pressure—I was always about to leave for somewhere—and with a minimum of inconvenience to me, meaning that Judy Seelig, from CTI (which represents Otrona in my area), would come out to Chaos Manor with new drives, new data separator chips, new software, etc., and see if that didn't solve the problem.

Adelle was an older machine. She'd been on more than a dozen trips with me, including a long train trip in Italy. All these changes were designed to bring her up to date so that she'd be similar to what Otrona is shipping now.

Sigh; while the improvements were obvious, none of those measures solved the disk speed problem. The wizards at Otrona concluded

that the problem was with the disk controller chip itself, but by then Judy had had enough of driving out here every Saturday morning. She came one last time and swapped Adeline for Adelle. Then, before Adelle went back to the factory, Judy took some of the parts, like the screen, to swap into her own system: Judy's Otrona is even older than Adelle.

Thus I'm writing this on Adeline, who has been with me to all my speeches and conventions this month and has also been in nearly constant use as an auxiliary machine at home. No hitches, no glitches, no problems.

I can continue to recommend the Otrona Attache as both sophisticated and reliable. The machine is easy to use, the keyboard is reconfigurable (we have one disk set up to change the keyboard into one optimized for the WRITE text editor we favor), and the software package is very good. I carry mine to all my conferences and speeches, and just about everyone is impressed. They particularly like the Charton graphics package that comes with the Otrona.

Personal Basic

The war between Digital Research and Microsoft continues. DR is heating it up with Personal Basic, which is an interpretive BASIC for CP/M-86 and MS-DOS.

Personal Basic is a lot like Microsoft's MBASIC. That's not a coincidence.

On the other hand, it isn't identical. Some of the differences are significant. Others are simply annoying.

The most annoying is that there's no FILES statement in Personal Basic. Thus you cannot get a list of disk files from within a BASIC program. This seems very odd; surely Digital Research of all firms would know how to implement it. Digital's CBASIC and CB-80 don't have the feature either; I wonder if it's a policy?

I send copies of the column to the people affected. The man who wrote Personal Basic just called in some anxiety. The proper statement is DIR, which is what CP/M uses. In my

micro/SPF™ educates micros so you don't have to re-educate programmers.

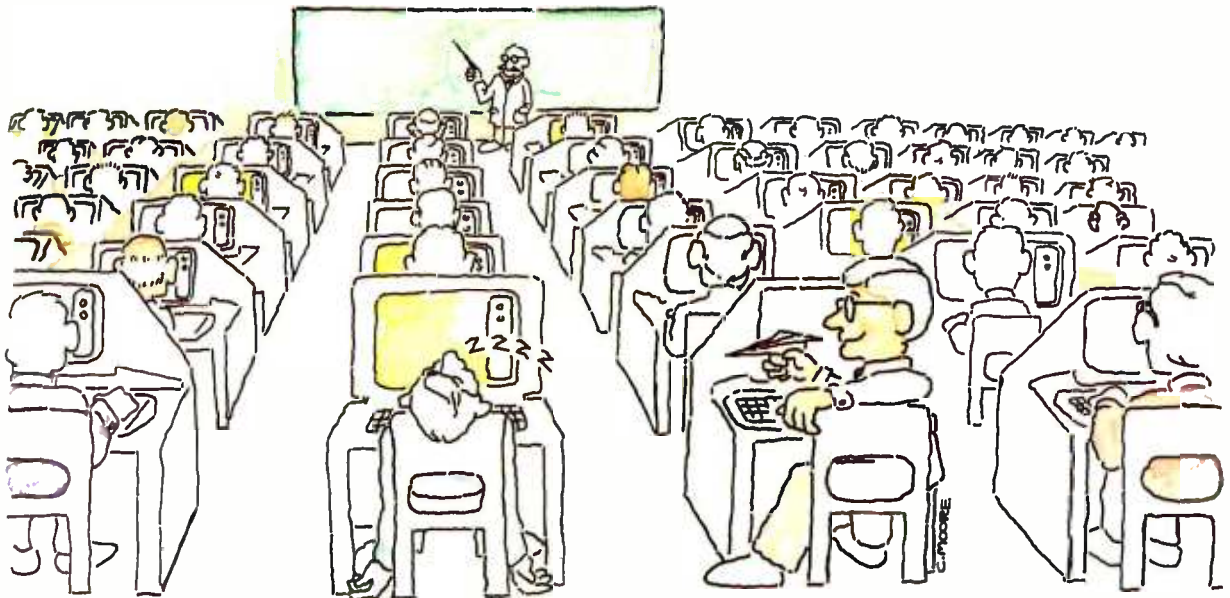

Are you considering microcomputers for programmers already familiar with SPF? Consider the time and effort you could save if re-educating programmers wasn't required.

Now it isn't.

micro/SPF™ is an advanced programming tool. It is designed to accommodate professional programmers familiar with SPF.

Re-education is not required.

What's more, micro/SPF™ is available for the IBM Personal Computer. Plus, other compatible 16-bit microcomputers.

And, future releases will include all extensions of the mainframe environment.

Stop wasting valuable time re-educating experienced programmers.

More and more companies realize the potential value of using microcomputers to perform business functions. But the need for more sophisticated software, designed to satisfy experienced programmers, has become evident.

Seasoned professional programmers have

come to expect less from micros. Less performance. Less sophistication. And less flexibility.

Not anymore.

With micro/SPF™ experienced programmers can quickly and easily recognize the SPF emulation characteristics and operate more efficiently.

Also, they can make better use of their personal computing time.

Why?

Because the problems and frustrations typical of current microcomputer software are eliminated.

micro/SPF™ emulates mainframe software on microcomputers.

micro/SPF™ executes under PC-DOS, MS-DOS and the family of Digital Research's CP/M-86 operating systems.

We've educated micros, so you don't have to re-educate your programmers.

To find out more about micro/SPF™ and other mainframe software tools, contact us. Also available through Digital Research, Inc.



PHASER

Mainframe Software for Micros

PHASER SYSTEMS, INC., 24 CALIFORNIA ST., SAN FRANCISCO, CA 94111 • 415-434-3990

PC-DOS and IBM are registered trademarks of International Business Machines Company. CP/M-86 is a registered trademark of Digital Research, Inc. MS-DOS is a registered trademark of Microsoft Corp.

defense, that was not listed under FILES, COMMANDS, or NAMES in the index.

A big difference between Personal Basic and MBASIC is the way programs are stored. MBASIC wants you to do

SAVE "D:Filename" or
SAVE "D:Filename.ASC",A

In the first line, the file would be stored as a .BAS file, and the storage format would be binary; this has advantages in storage space and speed

of loading. The second line would produce an .ASC file that would be in ASCII characters, i.e., something readable by people as well as machines. To recover a program, you LOAD it:

LOAD "Filename"

Personal Basic wants you to do

SAVE Filename

in order to save a program. It will be stored as Filename.BAS and will be

in ASCII format; there is no provision for storing programs in binary format.

To get a Personal Basic program back, you don't LOAD; you type

OLD Filename

and if you alter the program and want to save it, you type

REPLACE Filename

I suppose there's nothing wrong with doing things this way; indeed, I recall being pretty tired of getting syntax errors when I didn't put the quote marks around a program name for LOAD or SAVE operations.

A lot of the differences between DR Personal Basic and Microsoft MBASIC are like that: possibly improvements, but not dramatic improvements; and they do take getting used to. The editing feature is *very* different. As of this moment I don't like DR's as much as Microsoft's, although I'm prepared to be convinced it's mostly a matter of what I'm used to, because it has some nice features not found in the MBASIC statement editor.

There are other differences. Take error messages, for example. If you type something incomprehensible, MBASIC prints the message "SYNTAX ERROR." Personal Basic prints "Something is wrong," which doesn't seem a great deal more helpful; however, Personal Basic also puts a small caret (^) at the point in your command line where the interpreter got lost. This can be useful.

The best and worst parts about Digital's Personal Basic are the documents.

The best part is a tutorial that teaches a fair amount about BASIC for people who've done zero BASIC programming. It's well written and reasonably well indexed, but it's not complete and doesn't tell much about advanced features like random-access files.

The tutorial is well written in English, but that's not true for the reference manual. While better than the old Digital Research documents (the ones translated into binary and

act
improve
effect
enable
excel



655 Redwood Highway · Suite 311 · Mill Valley, Ca. 94941
Software to be released December 1983 through selected Distributors.



For users of Apple, IBM, TRS/80, Atari, Commodore, Texas Instruments, and other brand name computers:

Here's the easiest way to buy quality diskettes at discount prices

Now you can get error-free double density diskettes by IBM, Control Data, Maxell and Verbatim delivered to your door. For some of the lowest prices around.

You save because we ship huge volumes of magnetic media in boxes of 10.

To order, use this form.

For even faster service, call toll-free.

1-(800)-FLOPPYS or
1-(800)-521-5700

Michigan • 1-800-482-4770

Canada • 1-800-265-4824

Alaska/Hawaii • 1-800-821-9029

ALL MAJOR CREDIT CARDS ACCEPTED

Shipping & handling F.O.B. Southfield

Transaction Storage Systems Inc., Southfield, MI 

Size	IBM Qty.	Verbatim Qty.	Control Data Qty.	maxell Qty.
5-1/4" SS	24.90	23.90	19.90	28.90
5-1/4" DS	39.90	34.90	29.90	41.90
8" SS	24.90	—	19.90	—
8" DS	39.90	—	29.90	—
Sub Totals	\$ _____	\$ _____	\$ _____	\$ _____

Name _____ Title _____

Company _____

Address _____

City _____ State _____ Zip _____

AMEX MASTERCARD VISA

Card # _____ Exp. Date _____

Shipping and handling 1-6 boxes add \$4.00 per order

7 or more add \$6.00 per order.

Clip and mail today to: **Transaction Storage Systems, Inc.,**

22255 Greenfield Road, Southfield, MI 48075 

EXPECT A MIRACLE

Circle 479 on inquiry card.

then Swahili before being retranslated into English), this one really isn't very good. Worse, it gets truly obscure as soon as it tackles subjects too advanced for the tutorial.

Example: random-access files.

In order to have random-access files on a disk, each file must be exactly the same length. Let's suppose each file is 50 bytes long; to find record number 30, the program need only figure out where the 1500th byte is stored in that file; it goes and gets it and presents bytes 1501-1550. Similarly, if you want to alter the thirtieth record, the program writes the new 50-byte record in where bytes 1501-1550 were on the disk. This isn't particularly simple for the program, but it's easy for the programmer.

The problem comes when you specify what those 50 bytes are, and it's particularly tough if you want to compress the data.

Data compression is complicated, but it does save time and disk space. Consider: a single "word" for an 8-bit computer consists of 2 bytes. It can

take all values between 0 and 65,535 (or if we allow negative integers, between -32,768 and +32,767, more or less).

Suppose I have two integers, I1 = 2366 and I2 = 786, and I want to store them. What must I do?

If I store them in ASCII (human-readable) form, that will take 7 bytes; in addition, I will need a byte to separate the two numbers and another to separate the second number from any data following it. That's 9 bytes so far. This is the way CBASIC stores integers. It wastes space, but it's simple.

On the other hand, if I compress the data, I can do it all in 4 bytes: 2 for each integer. This requires two things: a routine that will convert my integers into binary (and back) and a way to tell my program that the first 4 bytes in a record are two integers.

Both Microsoft MBASIC and Digital Research Personal Basic do this. They do it in a slightly different way; Digital then thoughtfully supplies an option that allows you to read and

write compressed data in the same format as Microsoft.

Both recover compressed data through use of the dreaded FIELD statement. The FIELD statement isn't all that awful once you understand the theory. In our example above, for instance, the FIELD statement would be

FIELD #8, 2 as I1\$, 2 as I2\$

because we are going to store two integers, and each requires 2 bytes for storage. We've made a sort of map.

Now we have to convert I1 and I2 into strings. A special function converts integers to 2-byte strings (MKI\$). Of course they're not *real* strings; what they really are is binary numbers. They can't be real strings because they might contain goofy numbers such as 07 (which the computer interprets as a command to ring the bell). However, they're stored as strings and recovered that way.

We shove them into a record that is controlled through use of this particular FIELD associated with a particular file (#8 in this case). When we recover those numbers, the *value* of I1\$ will be our original integer 2366. A special function (CVI) can convert a 2-byte "string" into an integer, and we use it: I1 = CVI(I1\$).

You can have more than one FIELD. If this is confusing, don't worry about it. It's going to get worse.

Digital Research now tells us: "Reallocating field space does not cancel the original mapping; rather, the two maps coexist. For example, if you specify

FIELD #10, 20 AS X\$, 40 AS Z\$,
10 AS Y\$

and

FIELD #10, 70 AS N\$

the first 20 bytes of N\$ are also in X\$, the next 40 also in Z\$, and the final 10 also in Y\$.

"Do not use an INPUT or LET statement with a variable that was declared in a FIELD statement. Otherwise, the variable's pointer moves to string space instead of to the buffer."

New!

BYTEWRITER®

**DAISY WHEEL
PRINTER/TYPEWRITERS**

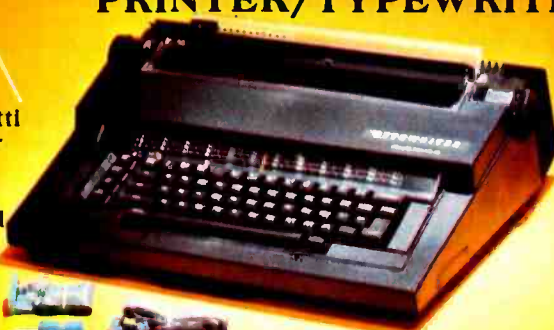

- Full Olivetti typewriter warranty when purchased complete

Complete BYTEWRITER using:

Olivetti Praxis 30 portable	\$495
Olivetti Praxis 35 portable	\$545
Olivetti Praxis 40 office machine	\$645
Interface only-wired and tested	\$165

The parallel interface mounts entirely internally. Interconnecting cables available for most computers.

BYTEWRITER

125 NORTHVIEW RD., ITHACA, N.Y. 14850
(607) 272-1132

NOVATION CATS® VS. HAYES

Take a close look at both and you'll discover the Novation Smart-Cat™ modems give you everything you get with the Hayes Smartmodem—plus some critical extras.

OFF-THE-SHELF SOFTWARE

It's a draw. There's a lot of software for both.

For the Smart-Cats, there's ASCII Express™, The Pro™, Crosstalk 16™, Transend™ and more that let you do virtually anything you'd like. No compromises.

ONLY ON THE CATS

Instant status report

Place a call and your Smart-Cat knows what's going on every micro-second. Fail to get a dial tone? Your Smart-Cat tells you right now. With Hayes, you can wait through an entire call-answer cycle—then wonder what went wrong.

Dial tone detect on long distance

With special long distance telephone services, you must wait for dial tone part way through a long

dialing sequence. The Hayes modem relies on a pause—which works if things go just right. Smart-Cat waits, detects the tone, then completes dialing. It always works.

True, automatic "redialing"

The Hayes modem gives you a simple Repeat of the last command. Enter another command since you last dialed and you've lost the number.

Smart-Cats give you both Redial and Retry. Redial calls the last number dialed no matter what has happened in between.

Retry keeps retrying on a busy signal. A handy time-saver.

Easy on-line commands

With Hayes, you need escape and re-entry codes when on-line. With the Cats, just enter a single command—or even string a bunch together. Smart-Cats follow them, then go back on-line. No lost contacts. No lost data.

Test everything

The Hayes modem has only internal self-testing. But the Cats do

more. They also test the rest of the communications loop. At 1200 baud, the Cats can automatically run data over the line, through the other modem and back. You know if your modem is right. You know if the rest of the loop is right, too.

NOVATION LSI VS. HAYES DISCRETE COMPONENTS

Large Scale Integrated (LSI) circuits—more and more logic on a smaller and smaller chip—is today's technology. It's the breakthrough that has made personal computers possible. It eliminates all kinds of parts and adds all kinds of logic.

Our LSI does something else extremely logical. It cuts costs.

\$595* (NOVATION) VS. \$695* HAYES)

The Smart-Cat 1200 is \$100 less than the Hayes Smartmodem 1200. Now that's a lot smarter.

Lower price, LSI technology, lots of software—and no waiting. You can see them now at your computer store and let your computer out tonight.

How to make a smarter buy on a smart modem

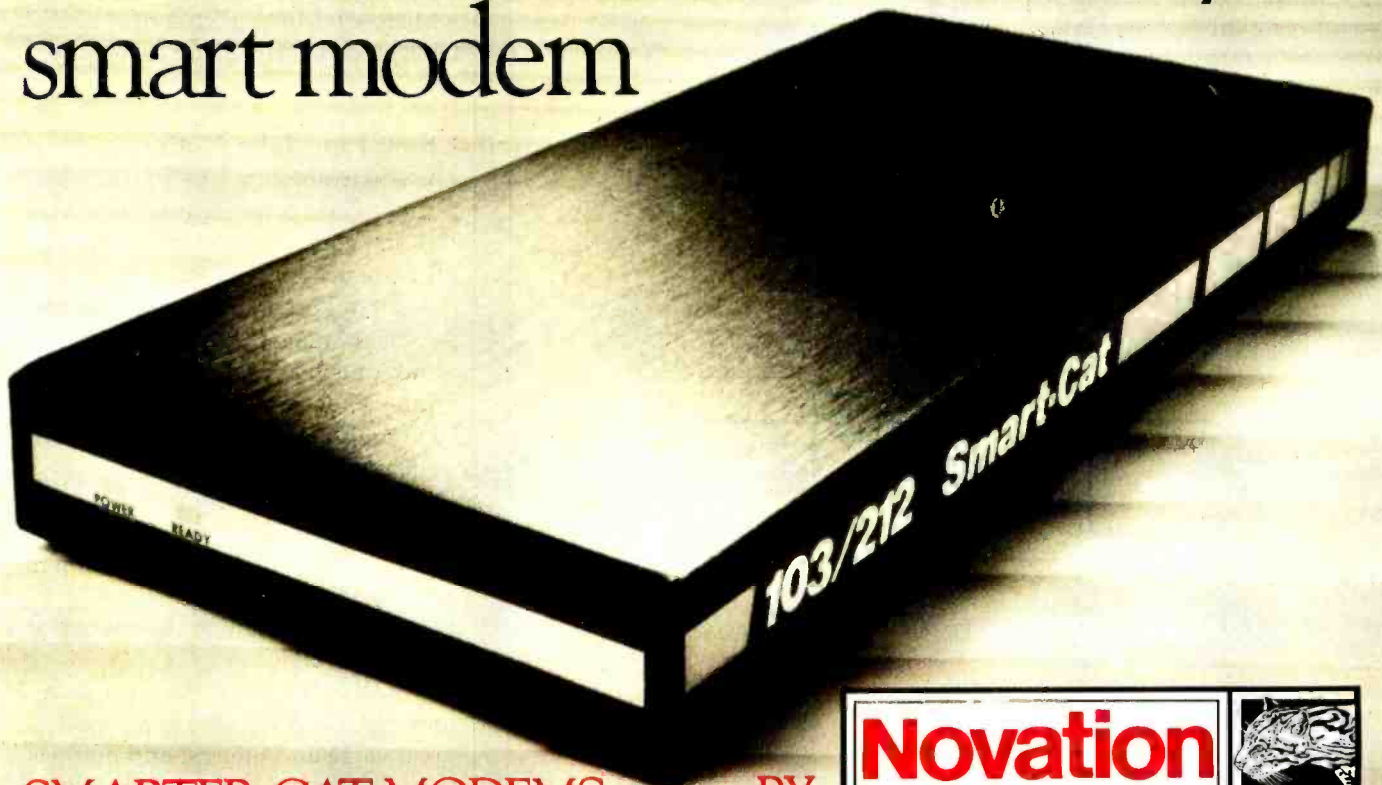

SMARTER-CAT MODEMS

BY

Novation



Novation, Inc., 20409 Prairie Street, Chatsworth, California 91311 • (800) 423-5419 • In California: (213) 996-5060

ASCII Express™ "The Pro" is a trademark of Southwestern Data Systems • Crosstalk 16 is a trademark of Microstuf Inc. • Transend is a trademark of SSM Microcomputer Products, Inc. • Smart-Cat is a trademark of Novation • Hayes is a trademark of Hayes Microcomputer Products, Inc.

*Suggested retail prices

Circle 331 on Inquiry card.

DATA EXCHANGE/64K SPOOLER

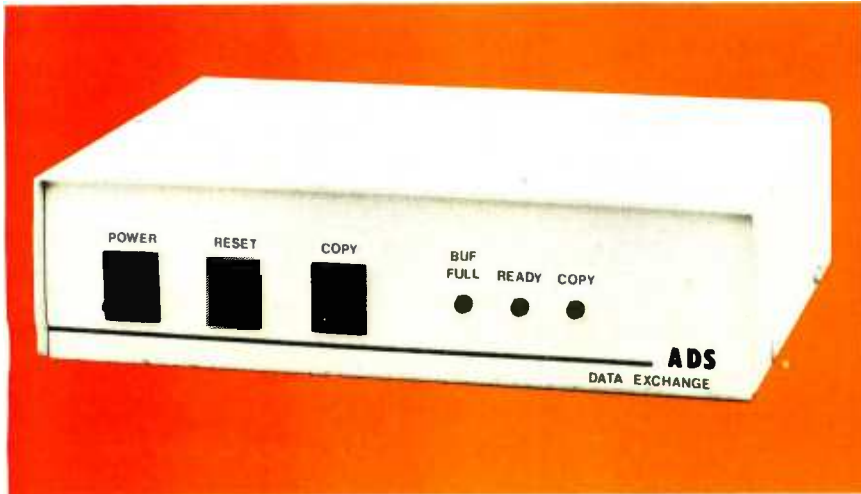

The ADS-8212 DATA EXCHANGE/64K is a computer independent interface converter and print spooler. It can be installed between virtually any computer and any peripheral.

Data can be input in either serial or parallel, stored in its 64K bytes of RAM, and output serial or parallel. Serial ports support baud rates from 50 to 19,200 and both hardware and software handshaking. The input and output ports are completely independent: input data with one protocol and baud rate and output it with a different protocol and baud rate. Selections are dip switch selectable.

A unique feature is its ability to make unlimited numbers of copies. Hitting the copy button will send another copy to the printer. When done making copies, hit the reset button to clear the memory.

Included with the DATA EXCHANGE/64K are two 4 foot output cables, one parallel cable with standard Centronics type connector and one serial cable with standard DB 25 connector. Standard plugs are supplied for input ports.

Suggested list price: \$339.00

Dealer inquiries welcome.

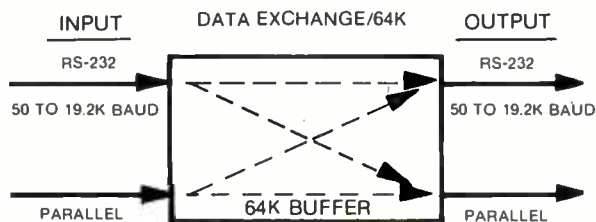

Available at your local dealer or contact

ADS ANTEX DATA SYSTEMS
 A Division of International Antex Inc.
 2630 California Street
 Mountain View, California 94040 ■ Phone (415) 941-7914
 Telex: 348 399 "KARMIGA LTOS"

I read that five times before I could figure out what it meant. It says that if you do one FIELD statement making one allocation (mapping) and another *using different variable names* doing another, then when you read in the data from a random file you can treat it either way: if you ask for N\$, you'll get all 70 bytes of the record; if you ask for Z\$, you'll get the middle 40 bytes. This is useful if you don't want all your records to have identical structures. (They must, however, all have the same *length*.)

Microsoft doesn't explain it a lot better, but it does give more examples of programs making use of files, so that it's a little easier to puzzle out how it's done.

Someday a software publisher is going to explain complex stuff like file structures as well as the simple stuff. That hasn't happened yet. Digital Research's Personal Basic tutorial is a step in the right direction, but it stops far short of what's really needed. Oh, well.

When I get my PC running properly, I'll benchmark Personal Basic against Microsoft MBASIC. My subjective impression is that they're pretty comparable, but I don't have a Microsoft MBASIC that runs under CP/M-86, so I can't do actual tests yet.

CB-80 Fans Take Notice

CB-80 (compiling CBASIC) also has a means for compressing data and has its equivalent of the dreaded FIELD statement. CB-80 makes use of a Digital Research program called Access Manager; with it you can write some really complex CB-80 programs. Indeed, you can write database programs that rival dBASE II in their power and complexity.

I'll have a lot more on Access Manager in a later column; meanwhile, serious CB-80 programmers ought to be aware of it.

They also ought to be aware of Software Magic.

Al Dallas is a part-time programmer. He has developed some tools of great value and interest and markets them under the firm name Software Magic.

Dallas's tools consist of lots of little

YOU WANTED TO BE THE BOSS.

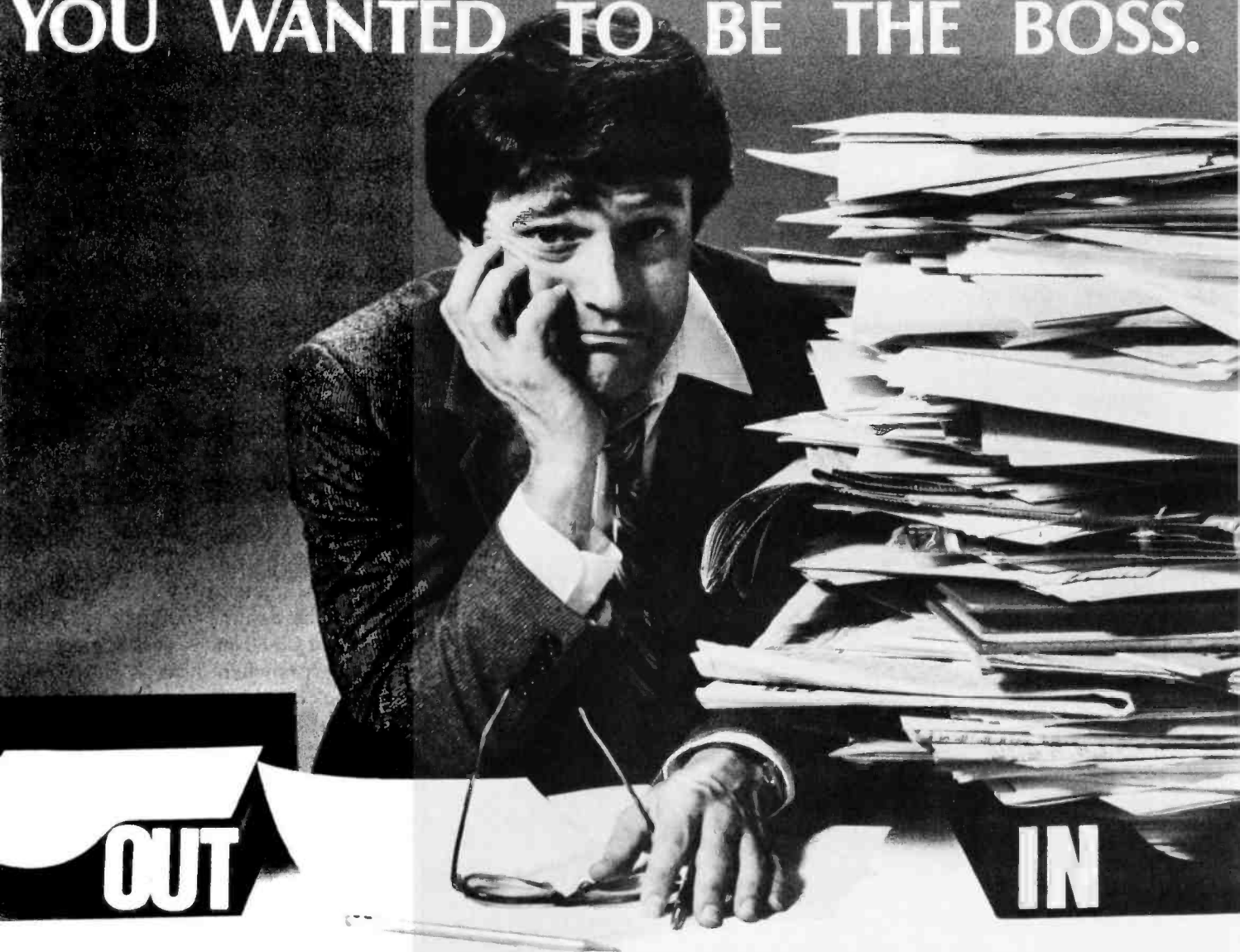

OUT

IN

YOUR BANKER WANTS THE LATEST MONTHLY INCOME STATEMENTS, BUT THE BEST YOU CAN GET HIM IS TWO MONTHS OLD.

Today, even the greatest entrepreneur can feel that he works for everybody but himself—the IRS, the landlord, the banker, even the janitor.

WITH THE BOSS, YOU'RE THE BOSS AGAIN.

Business and computer experts agree the key to solving your business problems is the choice of software. Hardware equipment selection is second.

To be competitive today means handling large amounts of information quickly. To be on top tomorrow means managing much, much more.

The Boss Business Software Products are comprehensive business software programs which get you information you need, as you need it, when you need it and the way you need it. *You know your financial picture at every moment.* You don't have to wait to close out the books at the end of every month.

The Boss takes care of all your business needs, your financial accounting, payroll, inventory and time billing.

WITH THE BOSS, YOU'RE THE BOSS AGAIN.

The Boss Business Software Products are compatible with most hardware systems. Call Balcones Computer Corporation to learn more about making yourself the Boss again.

YES, Send me more information on The Boss.

NAME _____

COMPANY _____

ADDRESS _____

CITY _____ STATE _____ ZIP _____

PHONE _____

TYPE OF BUSINESS _____

For more information call toll free: 1-800-531-5483

Balcones Computer Corporation
5910 Courtyard
Austin, Texas 78731

THE BOSS BUSINESS SOFTWARE PRODUCTS

utilities that let you handle data with CB-80. As an example, he gives you the function CVI(I\$), which will convert a two-character string to an in-

teger, and the reciprocal MKI\$(I), which will turn an integer into a 2-byte string. There are lots of functions that call in the contents of the

computer's registers; these are very useful if you're going to patch assembly-language routines into a CB-80 program.

Also included are date functions, functions for use with Access Manager, a really efficient SORT function based on the Quicksort algorithm, and other goodies. These are all made available as a library of functions you can call in a program and bring in at link time.

Al Dallas also has a book, *Inside CB-80*, that gives the addresses and actions of a whole lot of CB-80 routines; if you're heavily into mixing assembly-language routines into CB-80 programs, it is invaluable. It's a sort of advanced *grimoire* of CB-80 formulas; if you're not very familiar with CB-80, it won't do you any good.

For that matter, his Magic Library documents assume you know a good bit about CB-80 and Access Manager, although nowhere near as much as his book does. If you understand the dreaded FIELD statement, you can use Magic Library to good advantage. If you don't, you'll have to learn it elsewhere.

Whimper . . .

Sigh. The pile of unreviewed—indeed, sometimes unopened—software, books, and even hardware grows daily. By its very nature, this column can tackle only stuff that I've found time to use. I cannot and will not write "reviews" from spec sheets and PR notices. Alas, that dooms me to fall farther and farther behind, but there seems no help for that. To those who sent products for review, I can only counsel patience. I'm dancing as fast as I can. ■

Jerry Pournelle is a former aerospace engineer and current science-fiction writer who loves to play with computers.

Jerry Pournelle welcomes readers' comments and opinions. Send a self-addressed, stamped envelope to Jerry Pournelle, c/o BYTE Publications, POB 372, Hancock, NH 03449. Please put your address on the letter as well as on the envelope. Due to the high volume of letters, Jerry cannot guarantee a personal reply.

Items Reviewed

Access Manager	\$300
Personal Basic	\$150
Digital Research POB 579 Pacific Grove, CA 93950 (408) 649-3896	
Attache Computer	\$2995
Otrona Corporation 4755 Walnut St. Boulder, CO 80301 (303) 444-8100	
CB-80 Book	\$74.95
Magic Library	\$49.95
Software Magic 11669 Valerio St., #213 North Hollywood, CA 91605 (213) 765-3957	
Executive Computer	\$2495
Executive II Computer	\$3195
Osborne Computer Corporation 26538 Danti Court Hayward, CA 94545 (415) 887-8080	
FORTRAN 8087 Library	\$200
Avant-Code 1508A Oxford St. Berkeley, CA 94709 (415) 549-3257	
Kaypro 4 Computer	\$1995
Kaypro Corporation 533 Stevens Ave. Solana Beach, CA 92075 (619) 481-4300	
Modula-2 for the IBM PC	\$495
Logitech 165 University Ave. Palo Alto, CA 94301 (415) 326-3885	
Problem-Knowledge Coupler	Not available
PKC Corporation RR 1, Box 630 Cambridge, VT 05444	
Super-19	\$49.95
Extended Technology Systems 1121 Briarwood Bensalem, PA 19020	
8087 Hardware Board	\$495
Hudson and Associates POB 2957 Santa Clara, CA 95051 (408) 554-1316	

Accept no substitutes.

If you're looking to buy a dBASE-like system, you'll really like dBASE II®

dBASE II is the relational database management system (DBMS) we introduced to the microcomputer world in 1980. It was the best, most powerful and easiest-to-use database management system available.

It still is.

You'll wonder how you managed without it.

Because it's so powerful yet so easy to use, dBASE II has become the standard for managing data with a microcomputer.

Doctors and lawyers, accountants and salespeople, stockbrokers and students, big businesses and small are all managing their data better with dBASE II. Books have been written about it. And other microcomputer data handling programs measure themselves against what dBASE II can do.

dBASE II turns data into a company resource.

dBASE II starts where file handling systems (such as our own Friday!™) leave off.

You get a running start on your business solutions because dBASE II includes a complete hands-on tutorial. You can quickly and easily create a full business information system because all of your data is at your fingertips. Using English-like commands, you add, delete, edit, display, print and manipulate your information.

Once you've decided on what you want done, you save the instructions so that even your least experienced personnel can perform the most complex business functions with two words: *Do Invoices*, *Do Payroll*, *Do anything that needs to be done*.

Your data and your programs are independent, so you can change one without changing the other; in fact, change the way you do business without destroying what you've done.

And dBASE II even simplifies conversion from your present system, and can handle data from other programs, or create files that other programs can use.

Circle 46 on inquiry card.



It's the most advanced information management tool available for your microcomputer. And it's only \$700 (suggested retail price).

The best selling DBMS known to man.

dBASE II struck a responsive chord in the business community when it was introduced and quickly became the best selling database management system made for any computer, micro or mainframe.

To see why, drop by your nearest computer or software store and ask for a demonstration. Then take a package home and use it for 30 days. If it's not everything we said it was, return it and get your money back.

But we think you'll keep it.

Can over 150,000 users be wrong?

Ashton-Tate, 10150 West
Jefferson Boulevard, Culver City,
CA 90230. (213) 204-5570.

ASHTON · TATE ■

©Ashton-Tate 1983
dBASE II is a registered trademark and Friday! is a trademark of Ashton-Tate.

TK!SOLVER EXPLAINED

TK!Solver does for equations what word processing did for words.

The first thing you should know about the TK!Solver™ program is that it is not a spreadsheet. Instead, it does something completely unheard of (until now!)—it turns your personal computer into a voracious equation processor.

The next thing you should know is that if the TK!Solver program can't make life with your personal computer easier (and pay for itself), even if you use it only 15 minutes a week, you are a very rare person.

And finally, you should know exactly what equation processing is, and how it works. If you keep reading this, you will.

Equation processing with TK!Solver, or problem solving made easy.

The best way to understand what the TK!Solver program is, is to understand what it does. The following simple example is designed to do just that. If you're still a little in the dark after reading it, stop in at your local computer store for a very enlightening hands-on demonstration.

Begin by setting up your problem. The TK!Solver program lets you do it quickly, easily, and naturally. For example, a car costs \$9785. What would be the monthly payment on a three-year loan if the down payment is 25% and the interest rate is 15%?

STEP 1. Formulate the necessary equations to solve your problem and enter them on the "Rule Sheet" simply



by typing them in (as in the screen photo). For example: "price-down = loan."

STEP 2. Enter your known values the same way on the "Variable Sheet." For example: "9785" for price. You may also enter units and comments, if you want.*

STEP 3. Type the action command ("!" on your keyboard) to solve the problem.

STEP 4. TK!Solver displays the answer: the monthly payment is \$254.40. **Backsolving, the heart of TK!Solver.** Now that you've defined

the problem and solved it, TK!Solver's unique backsolving ability also lets you think "backwards" to solve for any variable, regardless of its position in the equation. For example, if you can only afford a monthly payment of \$200, you can re-solve the problem in terms of that constraint. The TK!Solver program will solve the problem, displaying your choice of a higher down payment, a longer loan term, or a lesser interest rate. This unique backsolving capability forms the basis of TK!Solver's remarkably flexible problem-solving ability.

SOLVER UNLIMITED:

Also, as you can see from the example on the screen, TK!Solver deals not only with single variables, but with entire equations and sets of simultaneous equations. It also deals with much more complicated problems than this one. How complicated? That's up to you. What kinds of problems? That's up to you, too, but popular applications include finance, engineering, science, design, and education.

Other extremely useful and interesting things TK!Solver does.

Aside from its basic problem-solving abilities, the TK!Solver program performs a number of pretty fancy tricks. Like: *Iterative Solving*; in which TK!Solver performs successive approximations of an answer when confronted with equations that cannot be solved directly, (like $\exp(x) = 2 - x \cdot y$ and $\sin(x \cdot y) = 3 - x - y$). Like: *List Solving*; in which TK!Solver attacks complete lists of input values and solves them all, allowing you to examine numerous alternative solutions, and pick the one you like best. Like: *Tables and Graphs*; using the values you produced with the List Solver, the TK!Solver program will automatically produce tables and graphs of your data. You can look at your formatted output on the screen or send it to your printer with a single keystroke. And like: *Automatic*

*You can easily define appropriate unit conversions on the unit sheet.

Unit Conversion; in which TK!Solver lets you formulate problems in one unit of measurement, and display answers in another. Very convenient what with all this talk about going metric.

The TK!Solver program also provides a wide variety of specialized business and mathematical functions like trig and log and net present value.

Then, there's TK!Solver's on-screen Help facility that provides information on commands and features any time you want it. Just type "?" and a topic name.

And of course the TK!Solver program combines all these features in one *integrated program*.

TK!SolverPacks make problem-solving a picnic.

TK!SolverPack™ application packages are specially developed by experts in specific fields. Each package contains a diskette with about a dozen models that include the necessary equations, values, and tables for solving a particular problem. The models are usable as-is or you can easily modify them.

TK!SolverPack application packages available from Software Arts include Financial Management, Mechanical Engineering, Building Design and Construction, and Introductory Science. Additional TK!SolverPacks are on the way from Software

Arts, McGraw-Hill,™ and others.

We know you're out there. No matter who you are, or what you do, if it involves using equations, the TK!Solver program is an indispensable tool for you.

So, visit your local computer store today, and see TK!Solver in action. You'll be amazed at how much faster and more effectively you'll be able to work when you discover the power of equation processing with the TK!Solver program.

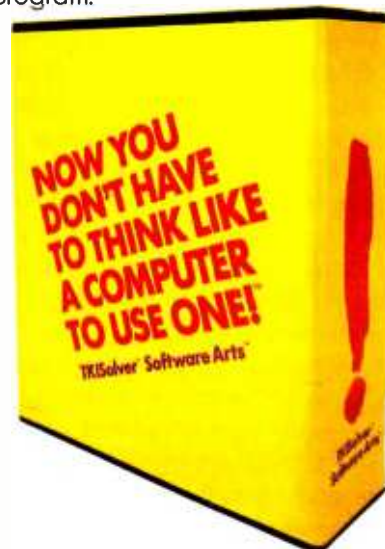

Software Arts™
The inventors of VisiCalc™

27 Mica Lane, Wellesley, Massachusetts 02181
617/237-4000

TK, TK!, TK!Solver, TK!SolverPack, The Problem Cruncher, the stylized ! and the slogan "NOW YOU DON'T HAVE TO THINK LIKE A COMPUTER TO USE ONE!" are trademarks or registered trademarks of Software Arts, Inc. SATN, TK!SATN and DIF are trademarks or registered trademarks of Software Arts Products Corp. Software Arts is a trademark of Software Arts, Inc. and Software Arts Products Corp. The TK!Solver program and the TK!SolverPack applications packages are products of Software Arts, Inc. which is solely responsible for their contents. VisiCalc is a registered trademark of VisiCorp.

Copyright © 1983 Software Arts, Inc. All rights reserved

P/N 100-092 P 8/83

The Unix Operating System

The Unix* operating system has descended from the realm of minicomputers into the midst of microcomputers, mating advanced software features to new and powerful 16-bit microcomputer hardware designs. This multiuser, multitasking operating system developed at Bell Laboratories offers powers and abilities far beyond those of normal microcomputer operating systems. Although Unix has attracted attention for some time, access to it usually has meant being part of a research project or attending an academic institution. A growing market now takes advantage of portable software environment; the Unix operating system, written in the C language (see August 1983 BYTE), makes the move from 16-bit microcomputers to IBM mainframes and the Cray-1 a simple process.

In the near future, Western Electric (the marketing arm of Bell Labs) will offer the newest version of Unix, System 5, for the 80286, 6800, 16032, and Z8000 microprocessors. Some of the licensed versions of Unix already available for microcomputers are Xenix (Microsoft's enhanced Unix) for the Altos 586; Xenix and UniPlus+ for the Apple Lisa; 4.1 BSD Unix and Venix for Digital Equipment Corporation's Professional 350; the Fortune 32:16 with Unix version 7; Venix and Xenix for the IBM Personal Computer; and TRS-Xenix for the Model 16B. Western Electric is rumored to be planning a low-cost Unix microcomputer as well.

Computer professionals who once refused to take microcomputers seriously now take a second look at the powerful 16-bit microcomputers and the advanced software-development environment that Unix offers. Most find the vast collection of software tools (small general-purpose programs) in Unix a boon to their work. Other prominent features of the Unix operating system include its hierarchical (tree-structured) file system that allows you to break up your work area into easily identified groups, the ability to run several programs simultaneously, a flexible command shell that lets you customize the Unix system, I/O (input/output) redirection, and automatic "piping" of the output of one program into the input of the next program.

Unix also enables programs to make use of its advanced features. Applications for microcomputer Unix systems, everything from Wangwriter-like word-processing programs to accounting applications, are bursting onto the scene. Many of these are migrating from the minicomputer/mainframe environment and have multiuser/multitasking capabilities. Unfortunately, popular microcomputer programs written in assembly language may be slow in coming to Unix and hampered by a single-user, single-task orientation. The flexibility of Unix's user interface allows menu-driven command shells, such as those offered by Fortune and Altos, that make Unix simple to learn and use.

Unix systems are selling. The Internal Revenue Service (IRS) placed an order for \$30-million worth of the Zilog System 8000 with the Unix operating system to use for word-processing, financial-spreadsheet, and data-management applications. (One of the largest users of Unix systems outside the Bell system is the Federal Government.) Even McDonalds, looking for a break today, is buying Unix systems. With its expanding availability on microcomputers, the second coming of Unix is here.

— Bruce Roberts

- 132** **The Unix Tutorial, Part 3: Unix in the Microcomputer Marketplace** by David Fiedler

- 160** **Unix and the Standardization of Small Computer Systems** by Jean L. Yates

- 170** **A Tour Through the Unix File System** by James Joyce

- 187** **The Unix Shell** by Stephen R. Bourne

- 209** **Unix as an Application Environment** by Mark Krieger and Fred Pack

- 219** **Usenet: A Bulletin Board for Unix Users** by Sandra L. Emerson

- 241** **The Unix Writer's Workbench Software** by Lorinda L. Cherry and Nina H. Macdonald

- 253** **Typsetting on the Unix System** by Bill Tuthill

- 266** **Moving Unix to New Machines** by Michael Tilson

*UNIX is a trademark of Bell Laboratories.



The Unix Tutorial

Part 3: Unix in the Microcomputer Marketplace

Which software companies offer licensed Unix and which offer look-alikes and work-alikes

by David Fiedler

In the preceding two articles of this series, we've examined the features and facilities of the Unix operating system, looked at a few of the many applications programs available to use with it, and seen how users can customize their working environments in Unix to the point of creating their own applications using available utilities. This last article explains the differences between the various Unix versions and between true Unix and Unix look-alike systems. You'll also see what changes various software firms have made to the Unix system and some of the computers it runs on.

Implementations Old and New

Over the past 10 years six notable modifications of Unix have been available to groups outside the Bell System. In 1973, Unix Version 5 was released to selected educational institutions (version numbers were designated by the edition of the *Unix Programmer's Manual* released with the software). In 1975, Version 6 became the first incarnation of Unix to be sold to commercial firms as well as to schools. The most widely used version as recently as last year, Version 6 has been responsible for the

growth of the "Unix legend."

Because, under a government-ordered consent decree, the Bell System was forbidden to compete in the commercial marketplace, Unix was offered to all users under very restrictive terms. A source license only would be granted, and the software would be offered as is, with no support, no refunds, no warranty, and no maintenance.

These terms were decidedly uncompetitive because a Unix license would cost a company \$20,000 (educational institutions were charged \$200), but a few firms felt the improved productivity achieved with Unix was worth the fee.

Programmer's Workbench, more commonly known as PWB, was essentially Version 6 with certain important utilities added. Among these were:

- the Source Code Control System (SCCS), which allows you to keep account of changes to a text file (whether program source code or an epic poem in German) so the text at any stage can be recreated
- a remote-job-entry (RJE) facility that lets Unix users process batch jobs on an IBM/370 system

- the *nroff* and *troff* packages for text formatting and typesetting support

The advent of Version 7 in 1979 brought new attention to Unix. Many of the previous rough spots had disappeared, the maximum file size had grown to 1 gigabyte, and a standard I/O (input/output) library had been introduced. During this period, microcomputers running Unix appeared, and Unix look-alikes such as Whitesmiths' Idris and Mark Williams' Coherent emerged.

While it sometimes seems as though Version 7 has been around for a long time, in fact it had been on the market for only two years when System III was announced in late 1981. Relatively few architectural changes were made, but System III consolidated the most important features of Version 6, PWB, and Version 7, thus allaying any uncertainty of potential customers as to which version was best. A new pricing policy was instituted under which licensees could offer binary sublicenses to their customers for as little as \$100. In the view of many observers within the industry, System III was the beginning of AT&T's deeper commitment to the Unix operating system as a com-



Photo 1: Digital Equipment Corporation's Micro/PDP-11 is a microcomputer version of the original PDP-11 that Unix was developed on. The system has a 10-megabyte hard disk (with floppy disks for backup) and 256K bytes of memory.

mercial product.

Unix System V was formally announced in January 1983, at the Unicom conference in San Diego. For the first time, users outside the Bell System would be working with the same version of Unix used by those inside, and they would be eligible for the same support, training, and service, as well. System V improvements included a redesigned file system for faster throughput and several internal changes for higher reliability.

AT&T's recent announcement that it would be supporting source code licensees for Unix System V on four advanced microprocessors (the Intel 286, Motorola 68000, National Semiconductor 16032, and Zilog Z8000) gave notice to the industry that AT&T intends to keep promoting Unix aggressively in the fastest-growing segment of the market.

Outside Bell Labs

Software developers are never

satisfied with anything—even Unix. From the day the first tape left Bell Laboratories, Unix has been made bigger and smaller, faster and slower, friendlier and more cryptic. Surprisingly, all this poking around by people intent on improving Unix actually yielded some useful results, including several variants that are commercially important on their own.

The noncommercial institution best known for its work with Unix is the University of California at Berkeley.

The Berkeley Computer Science Department, under the primary leadership of Bill Joy (now at Sun Microsystems), has added the following features (among others) to Unix:

- the *ex* and *vi* screen editors
- the INGRES database-management system
- a replacement for the standard Unix Bourne Shell, called the C-shell
- the general-purpose video terminal interface packages called *curses* and *termcap*
- larger disk-blocking factors and other performance improvements
- an assortment of useful general-purpose utilities such as *more*, *apropos*, *finger*, *head*, and *strings* (exotic names are a Berkeley hallmark)

As is typical with academic groups, the Berkeley people have been quite generous in sharing their improvements with others. While essentially the code of the Berkeley programs is in the public domain, much of it as distributed discloses Bell Labs' licensed Unix software and so may be sent only to Unix source licensees. Nevertheless, entire nine-track tapes full of this code have been sent around the world to licensed Unix sites. When distributed as a package, the Berkeley software is usually known by release numbers. The 4.1 BSD (Berkeley Software Distribution) package has been developed for the Digital Equipment Corporation (DEC) VAX line of computers, while other BSD releases are intended for PDP-11 computers.

Other groups have updated the Berkeley software in turn and made it more general in scope. Many of the Berkeley enhancements have been transported to 68000-based machines by Unisoft Systems as part of its popular Uniplus+ package. It is safe to say that a majority of Unix sites today run some programs originally developed at Berkeley. Even AT&T adopted several of these programs as part of its latest Unix System V release.

Commercial Enhancements

Interactive Systems (1212 Seventh St., Santa Monica, CA 90401) was the

first commercial organization with a Unix license. The company also has the distinction of being the first organization to offer hardware and software support for the Unix system. Since 1977, Interactive Systems has been distributing its own enhanced Unix system and set of utilities consisting primarily of what would today be called office-automation software. Collectively called the IS/1 system, enhancements include packages such as multiwindow screen editors (INed), improved electronic mail programs with Telex/TWX facilities (INmail), and word-processing packages (INroff, INtext). Once exclusively tied to DEC equipment, Interactive Systems now also supports smaller computers such as the Onyx and Plexus.

Another firm that's been around a while is HCR (Human Computing Resources, 10 St. Mary St., Toronto, Ontario M4Y 1P9, Canada). HCR has achieved a reputation for customer support while emphasizing a slightly different technical path from Interactive Systems. HCR specializes in transporting Unix to different processors (such as the Three Rivers Perq machine and National Semiconductor 16032), and enhancing it with technical improvements such as graphics and text overlay software. This last feature allows people using smaller processors in the DEC line to develop and run software that would normally be limited to larger machines such as the PDP-11/70.

Venturcom (139 Main St., Cambridge, MA 02142) has developed this kind of "shoehorning" to a fine art. Its Venix system manages to bring full Unix functionality to machines as small as the IBM Personal Computer and DEC LSI-11/2. Even with its small size, Venix adds real-time extensions that make it equally useful for larger computers. Venix has become quite popular for laboratory use and has given Venturcom a reputation for small-system expertise.

Microsoft (10700 Northup Way, Bellevue, WA 98004) is a name that has long been associated with microcomputer system software, yet the firm didn't offer Unix until relatively recently. While some early

versions of its Xenix system were developed by other software houses on contract, Microsoft has turned Xenix into a well-supported product with significant performance and reliability enhancements. Xenix is available on the Radio Shack Model 16 and Apple Lisa, to name just two recent versions.

The most widely used of the independently available systems is Uniplus+ from Unisoft Systems (303 West 42nd St., New York, NY 10036), a company whose specialty is the narrowest of all. Unisoft's sole business is transporting Unix System III to 68000-based computers, and the company has plenty of experience, having done this 50 times or so already. Anyone who buys a computer running Uniplus+ gets not only Unix System III but also some Berkeley enhancements as well as a few that Unisoft added. A good number of compilers and applications packages will work on any machine with Uniplus+, including the NCR Tower, the Apple Lisa, the Sun Workstation, and computers from Dual, Callan, Codata, Pixel, and Corvus.

Unix Look-alikes

All of the software systems mentioned so far are based on the original Bell Labs Unix that has been transported to a new computer or otherwise modified. There has also been a thriving business in developing operating systems that act like Unix to both the user and the applications code. Such look-alike systems occupy a significant portion of the market. When the first few Unix look-alikes were introduced, Unix sublicenses were priced in the thousands of dollars. Now that sublicense pricing has been substantially cut, look-alikes must both drop in price and have more functionality than before in order to stay competitive. Even so, it's historically been easier for computer manufacturers to deal with the look-alike vendors than with AT&T.

The first and best known look-alike system is Idris from Whitesmiths Ltd. (97 Lowell Rd., Concord, MA 01742). At this writing Idris is still compatible only with Unix Version 6, but it

GRAFOX

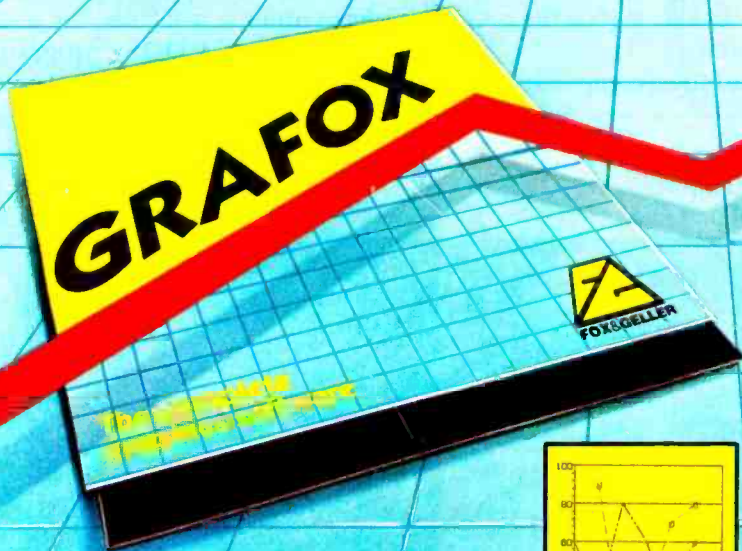

Introducing a whole new way of looking at data. Introducing colorful charts and graphs all at the push of a button. Introducing a powerful, easy-to-use data handling system that produces presentation quality graphics on most popular printers. Introducing GRAFOX, by Fox & Geller. The complete graphics software.

Turning data into colorful charts and graphs is what GRAFOX is all about. And GRAFOX does it faster and easier than any other stand-alone graphics package.

GRAFOX is powerful! With the ability to go directly into IBM BASIC* and .DIF data files and use the data for charts. And Fox & Geller's unique data-query capability enables GRAFOX to summarize data from thousands of records. Thus eliminating the need for the user to do any manual processing of raw material.

But most importantly, GRAFOX is easy-to-use. Requiring no prior experience.

If you want color charts or graphs on your screen, printer or plotter, you want GRAFOX. The powerful, new, complete graphics software from Fox & Geller.

*GRAFOX works with IBM BASIC and other comma delimited BASIC files. GRAFOX also graphs .DIF files such as those created on VisiCalc, 1-2-3, and DB MASTER.

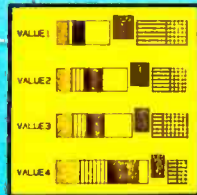
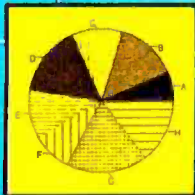
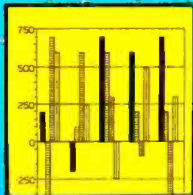
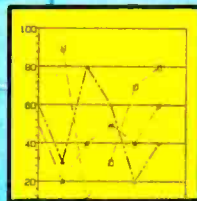

FOX & GELLER INFORMATION HOTLINE (201)-794-8883



FOX & GELLER

Fox & Geller, Inc. 604 Market Street, Elmwood Park, N.J. 07407 Fox & Geller, U.K. 17 Wigmore Street, London W1 England. 011 441-580-5816

Circle 189 on Inquiry card.

has retained a loyal following among its users due to its small size and high degree of portability. An 8080-based computer with bank-switched memory running full Idris can write a floppy disk that can be read by a VAX running Idris—something that can't generally be done with machines running Unix. Idris now runs on computers based on any of five different microprocessors.

Another prominent look-alike is Coherent, introduced a few years ago by the Mark Williams Company (1430 West Wrightwood Ave., Chicago, IL 60614). Coherent's main claims to fame are that it is fully compatible with Unix Version 7 and that it comes with almost as many utilities as does Unix. It has been transported to the PDP-11, Z8000, and 8086.

UNOS, written by Charles River Data Systems (4 Tech Circle, Natick, MA 01760), was intended as a look-alike but goes even further than Unix. While UNOS is compatible with Version 7, it also supports real-time operations for fast response where necessary, such as in labora-

tory work or industrial process control. CRDS's own Universe 68 computer uses UNOS, as does Motorola on that firm's Versabus-based system. UNOS seems to be limited to 68000-based systems as a design constraint.

Unix on Personal Computers

Ignoring for the moment the rapidly dropping prices in the computer world, most 16-bit computers that run Unix or Unix-like operating systems are out of the financial reach of many individuals. Never underestimate the ingenuity of software developers, though, who have made a variety of Unix-like systems targeted toward specific computers or processors. Like Unix, these systems all have hierarchical file arrangements and most are multiuser and multi-tasking, but some are closer to true Unix than others. While some of these systems may be able to run on floppy-disk-based computers, a hard disk or other high-speed disk drive is necessary to fully exploit the power of the software.

One of the oldest companies in the

microcomputer field, Cromemco (280 Bernardo Ave., Mountain View, CA 94043), introduced its Cromix operating system on the Z80 processor in 1981. Cromix might be properly termed a *work-alike* rather than a look-alike: while its user interface, utility programs, and file system are patterned after Unix, its system calls are not compatible. This somewhat limits Cromix in the marketplace because programs written for Unix are not automatically portable to Cromix (and vice versa). Nevertheless, Cromix has been popular among owners of Cromemco equipment because it can emulate their older operating system CDOS (itself a CP/M work-alike) and yields quite respectable performance even on a Z80-based system. With the advent of its dual processor Z80/68000 board, Cromemco introduced Cromix for the 68000, also. This version has probably been less of a success due to the large number of 68000-based systems running real Unix, but it still lets you run CDOS programs because the Z80 is present. It is prob-

AZTEC C — 'C' PROGRAM DEVELOPMENT SYSTEM
PORTABLE SOFTWARE APPLE CP/M IBM

WHY PROFESSIONALS CHOOSE AZTEC C

SOFTWARE SYSTEMS

- AZTEC C is the most complete implementation of UNIX V7 'C' available for microcomputers.
- AZTEC C is portable. 'C' code can be freely moved between UNIX V7 and microcomputer systems. AZTEC C is available for PC DOS (MSDOS), CP/M 86 (MP/M 86), CP/M 80 (MP/M 80), APPLE DOS, MODEL III (IV), COMMODORE 64, and ATARI. All versions of AZTEC C are source compatible.
- AZTEC C is a complete development system that includes relocating assembler, linkage editor, library utility, debugging aids, overlay support. Interfaces to Microsoft and Digital Research development software, and run time routines for I/O, utility, and scientific functions. Source for all library routines provided.
- AZTEC C generates fast native code for the 6502, 8080, Z80, 8088, and 8086.
- Cross compilers are available from PDP-11, 8086, 8080, and 6502 processors.
- Since its release in 1981, AZTEC C has been acquired by several thousand users. Commercial applications include a wide variety of business, scientific, word processing, database, entertainment and financial applications.

PRICE LIST

AZTEC C88	PC DOS (MSDOS)	\$249
AZTEC C86	CP/M 86 (MP/M 86)	249
AZTEC C80	CP/M 80 (MP/M 80)	199
AZTEC C11	CP/M 11 (MP/M 11)	199
AZTEC C65	APPLE DOS	199
AZTEC C65	COM 64 OR ATARI	199
AZTEC Cross Compilers	PDP-11	2,000
AZTEC Cross Compilers	Other	500

Order by phone or mail. Specify product and disk format. Check, Money Orders, COB, VISA, MC, and purchase orders. Cash acceptable. NJ add 6% sales tax.

MANK SOFTWARE SYSTEMS
 Box 55, Shrewsbury, NJ 07874

Order phone: (201) 780-4004
 Tech information: (201) 530-7997
 Tech support: (201) 530-7708

Shipping: COD, 2nd day delivery, or Canada, add \$5. Canada 2nd day or US next day delivery, add \$20. Outside North America, add \$20, and for 2nd day add \$75.

Number One Add-On Products for IBM PC



The Multifunction Cards that let you get the most out of your IBM PC.

AST Research Number One Add-Ons let you realize the full potential of your IBM PC or PC-XT without wasting valuable slot space. By combining your memory and input/output requirements on a single card, you can take advantage of more of the capabilities IBM designed into the PC, while leaving space for future enhancements as they are introduced. AST Research multifunction boards can add user memory from 64K to 512K to your PC bringing your PC memory to its maximum of 640K. You also receive the added features of serial ports, parallel ports, a clock calendar, game adapter port, and SuperPak™ — the utility diskette with the most powerful disk emulator and print spooler software available.

SixPakPlus™ — Up to 384K memory, serial port, printer port, optional game port, and clock calendar on a single card.

I/O Plus II™ — Up to 2 serial ports, optional printer port, optional game port, clock calendar on a single card. No memory.

MegaPlus II™ — Up to 512K memory, up to 2 serial ports, optional printer port, optional game port, and clock calendar on a single card.

ComboPlus™ — Up to 256K memory, serial port, printer port, and clock calendar on a single card.

Communication Products — Other AST Research Number One products include system enhancements and mainframe communications products such as 3270 SNA and 5251 terminal emulation, 3780 RJE support and AST-PCnet™ — the Local Area Network specifically designed for the IBM PC.

AST Quality

All AST Research multifunction boards come with the **AST "Plus"** — our unsurpassed reputation for quality, reliability, after-the-sales support, and overall design excellence — which give our products the best price/performance ratio in the industry.

AST Research Number One Add-On Products are available at Computerland, Entré, Businessland and other computer stores worldwide. Contact AST Research, Inc. for the dealer nearest you. (714) 540-1333/863-1333 TELEX: 295370ASTR UR



AST
RESEARCH INC.

PCnet is a registered trademark of Orchid Technology, Inc.

Circle 6 on inquiry card.

Give Wings to Your Apple

IMAGINE editing your BASIC programs up to 5 TIMES FASTER with powerful tools like SEARCH, REPLACE, INSERT and DELETE, just like your favorite word processor!

IMAGINE having over 50 special FUNCTION KEYS, reducing frequently used commands to only two keystrokes, AND creating your own custom keys to perform complex procedures with a single stroke.

IMAGINE having a large and growing library of helpful programs from Hollywood Hardware and your other favorite software companies RIGHT AT YOUR FINGERTIPS.

NOW IMAGINE having all of this power and more in your Apple ALL THE TIME, without having to search for the right disk, wait for it to load, or worry about memory conflicts, system crashes, reboots, etc.

YOU HAVE JUST IMAGINED. THE ULTRA ROM BOARD/EDITOR, a complete and expandable Program Development System in EPROM.

TIRED OF BROKEN PROMISES? If the Ultra Rom Board doesn't do everything we say, simply return it within 30 days for a COMPLETE REFUND.

CALL OR WRITE FOR COMPLETE INFORMATION.



CURRENT PRODUCTS:

- APB-102 Ultra Rom Board/Editor includes Global Editing & APB-1 \$190.00
- APU-2 Ampersand Utility Rom ? \$34.95
- AD-121602 High Speed 12 Bit, 16 Channel A/D Converter 75 microsec. \$299.95
- PRO-1 Professional Prototyping Board up to 52 (16 pin) sockets \$29.95
- CPU-1 48 Line Parallel Interface Board \$249.95

*APB-1 is a registered trademark of Apple Computer, Inc.

able that Cromemco will eventually adopt Unix and release a Cromix emulator to support its current customers.

Two work-alike systems for computers based on the underrated 6809 processor are Uniflex from Technical Systems Consultants (POB 2570, West Lafayette, IN 47906) and OS-9 from Microware Systems (5835 Grand Ave., Des Moines, IA 50312). Both systems are supported by a number of C compilers and applications programs on computers from several manufacturers.

Micronix is available from Morrow Designs (5221 Central Ave., Richmond, CA 94804) on its Z80-based Decision One line of computers only. This system is compatible with Version 6 Unix and includes a CP/M adapter that allows most programs written for that operating system to be run.

Owners of the IBM Personal Computer and its look-alikes can rejoice in the added power they get from the 8088 processor and the ability to handle over 64K bytes of memory. While several of the transportable Unix look-alike systems mentioned previously can run on the IBM PC, two newer products created expressly for the PC are worth some attention.

QNX from Quantum Software Systems (POB 5318, Station F, Ottawa, Ontario K2C 3H5, Canada) is a work-alike operating system that has the additional features of interprocess communication, prioritized tasks, and support of disk emulators to improve system throughput. A special utility allows you to transfer files between QNX and standard MS-DOS media. A C compiler and full-screen editor are included in the \$650 price.

A firm called Lantech Systems (861 Chartwell Dr., Dallas, TX 75243), which also specializes in user-transparent local-area network software, has announced an operating system called Unetix. Selling for only \$99, Unetix provides a special user interface that allows you to have as many as 10 concurrently active tasks, each one executing in its own separate window on the PC screen. Any or all of these tasks can be the included MS-DOS emulator, which lets you

6842 Valjean Ave., Van Nuys, CA 91406 • (213) 989-1204



Release Your Potential



With the p-System™ from

For: IBM PC & XT CORONA COLUMBIA EAGLE COMPAQ COLBY DOT HYPERION

Do you feel stifled by your operating system? The p-System from NCI will release you. It is the complete program development environment for the IBM Personal Computer and compatibles. This is the fast p-System with the special p-machine emulator developed by NCI.

The p-System from NCI gives you everything you need in one system at far less than the cost to add similar utilities to any other OS. It includes a powerful screen editor, a multi-function file manager and RAMdisk support for fast access to files. Dynamic memory allocation lets you create programs larger than 64K and a print buffer frees your

computer to perform other tasks while printing.

This operating system is stable, friendly and easy to use. Command options are presented on a menu requiring only a single keystroke. The 8087 Numeric Coprocessor Support allows extremely fast floating point calculations and the asynchronous I/O lets you use serial printer and communications routines.

With the p-System you can choose either UCSD Pascal, Fortran 77 or Basic as your programming language. NCI also offers hard disk support for the IBM XT, Corona, Columbia, Corvus, Tallgrass, Davong, Genie 5+5, QCS, Datamac,

Microdisk and Santa Clara. Corvus OMNINET support can easily be added as well as memory cards from AST Research and Tall Tree Systems, the Colorplus card and the Hercules graphics card.

When you buy the p-System from NCI you get technical support and complete documentation.

For full details call or write:

Network Consulting Inc.
Discovery Park,
Suite 110 - 3700 Gilmore Way
Burnaby, B.C. Canada V5G 4M1
(604) 430-3466

SPEED. PORTABILITY. RELIABILITY.

IBM Personal Computer and IBM Personal Computer XT are trade marks of International Business Machines Corporation. The p-System™ is a trade mark of Softech Microsystems, Inc. UCSD Pascal is a trade mark of the Regents of the University of California. OMNINET is a trade mark of Corvus Systems Inc. 5+5 is a trade mark of Genie Computer Corporation. Colorplus is a trade mark of Frederick Electronics.

run most current programs unchanged. While Unetix is a single-user system, it is compatible with Unix. Eventually, multiple PCs running Unetix will be able to share resources and communicate at high speeds.

What About Real Unix on Microcomputers?

Let's consider for a moment why Unix wasn't initially transported to machines both bigger and smaller than the PDP-11. While a college student might not need to justify spending hundreds of hours writing a C compiler for a new machine or moving Unix to that machine to satisfy his innate curiosity, the situation is different in the commercial world. The PDP-11 minicomputer line has, for years, been synonymous with good performance at a moderate price, and there were few competitors with as broad a base of installed systems as DEC had. It made little sense to move Unix to a larger computer, for what company would risk using an unsupported operating system on a \$300,000 machine? As for transporting Unix to smaller systems, for an entire decade, PDP-11s and similar machines were the smallest computers that could run Unix.

By the time Version 7 of Unix was announced in 1979, it was in use on hundreds of computers both inside and outside the Bell System, and thousands of computer science students at universities had begun to ask, "Why doesn't everyone use such a terrific system?" With this ground swell of support (and the entry into the business world of those university graduates), only one thing held back the general use of Unix—inexpensive, powerful hardware.

Only in the last few years, with the advent of 16-bit microprocessors, inexpensive semiconductor memory, and high-performance, low-cost hard-disk systems, has it been possible to bring the price of a powerful computer within reach of most small businesses and even many computer hobbyists. Unix, as both the first portable operating system and the first to emphasize programmer productivity over machine efficiency, is the



Photo 2: Plexus' P/40 uses multiple Z8000 microprocessors to achieve performance approaching that of a VAX.

natural choice for such systems.

First Implementations on Microcomputers: The Z8000

The first implementation of Unix on a microcomputer was the Onyx C8002, introduced in 1980. Based on the Zilog Z8000 microprocessor, the original Onyx was a desktop machine with an integral hard disk, cartridge-tape backup, 256K bytes of memory, and enough RS-232C ports to support eight users. At about \$20,000 including the Unix operating system, at the time it was about half the price of any other computer that ran Unix. While early versions were hard-pressed to keep up with multiple users, Onyx (25 East Trimble Ave., San Jose, CA 95131) kept enhancing its machine's performance. Today's Onyx offerings are much improved, and systems in its Sundance line are available with the entire computer built into a video terminal—including the cartridge-tape backup, which has become Onyx's hallmark.

Zilog (1315 Dell Ave., Campbell, CA 95008) was not far behind in introducing a computer based on its own processor. The Z-Lab Model 20, a precursor of Zilog's current System 8000 line, marked the first entry of

any microprocessor manufacturer into the Unix arena. At the time, this was especially important because it meant *factory support* for the software and hardware both. The Zilog computers run ZEUS (Zilog Enhanced Unix System).

Probably the most carefully designed Z8000-based systems come from Plexus (2230 Martin Ave., Santa Clara, CA 95050). Built around Intel's Multibus, all Plexus machines share the same basic philosophy: spare the main processor from carrying the full computing load. With this in mind, intelligent controllers are used to run the disk, tape backup, terminal ports, and Ethernet interface. The part of the operating system code that runs each set of peripherals is actually resident in the peripheral controller itself. This way, the Unix code running on the main processor needs to make only high-level requests of the controllers and can then continue processing user programs. The result is that a computer such as the Plexus P/40 (see photo 2) has performance comparable to a VAX at a fraction of the price.

An Aside on Chip Competition

Why were these machines based on the Z8000, rather than the Intel 8086 (which was available even earlier), the LSI-11/23, or the now-popular Motorola 68000? The fact that the 8086 has no memory management would allow users on the same 8086-based system to interfere with each other's programs and data; recently, however, engineers have found ways of adding this protection, and so 8086-based Unix systems have appeared. The 68000 wasn't available as a production item when the Onyx and Zilog machines were introduced, and other technical problems with this chip caused further delays in development of 68000-based computers. Perhaps as important as these factors is the similarity in architecture between the PDP-11 and Z8000: C compilers were developed quite early for the Zilog chip, a necessary first step for transporting Unix.

In spite of the early problems, the fact remains that the 68000 microprocessor can support a much larger

When it comes to superior performance, we study our lines very carefully.

Superior printer performance is not a fluke. It evolves from analyzing printed line after printed line. Taking the time to test and retest. After 30 years of manufacturing precision parts, we know that there are no shortcuts.

And so we took the Gemini-10X and methodically put it through its 120 cps pace. We achieved a print head life of over 100 million characters with an extremely precise dot alignment creating each crisp character.

So far so good.

Next, sophisticated performance demanded versatility. A wide choice of character sets, a buffer expandable to 8K, and the ability to interface with all popular personal computers. We added macro

instruction, giving Gemini-10X the capability to perform up to 16 operations with one command. We included as standard a paper feed system that has a friction and fully adjustable tractor feed. Then we even built in the dexterity to print graphics and text on the same line.

Done.

And, of course, staying the best means constant reviewing and fine-tuning. Keeping the Gemini easy to find, easy to afford and so reliable it can be warranted for up to twice as long as its major competitors.

Only the most careful engineering has built the new hard-working Gemini-10X. You'll applaud its performance.

stairTM
MICRONICS • INC

THE POWER BEHIND THE PRINTED WORD.

Computer Peripherals Division
2803 N.W. 12th Street, Dallas/Ft. Worth Airport, TX 75261



linear addressing space per user than any other current 16-bit microprocessor. It can also run at higher clock speeds and support virtual-memory schemes and has 32-bit internal registers for manipulation of larger numbers than its competitors. For these reasons, and due to the relatively painless porting services provided by Unisoft Systems, the 68000 has become the most popular processor for small computers running the Unix system.

This doesn't necessarily mean that

the 68000 is the best chip, though. Intel, Zilog, and DEC would be quick to point out that any software firm writing programs that could run only on 68000-based systems would be cutting out a great deal of its possible market. In general, it's almost impossible to make a blanket statement as to which of these four processors is best for high-performance Unix systems because so much depends on the overall architecture of the machine. Selecting a computer that runs Unix should be done on the

basis of available software, expandability, adherence to industry standards, support, service, and price—not just the type of processor used.

A Few 68000-Based Computers

Due to the large number of similar 68000-based systems in today's market, we'll examine only a few that are representative, innovative, or unique in some way.

Fortune Systems' 32:16 machine, for example, has won a great deal of admiration for its introduction of a menu shell that lets even novice users perform tasks ranging from file copying to system maintenance by following menu choices. Included with the Fortune machine is a powerful word-processing package and a stripped-down version of Unix. The C compiler and many development tools are available at extra cost, but because Fortune's chief market is executives, this isn't considered a great drawback. Fortune's base price of \$5000 created quite a stir when the system was introduced, although this is for just a bare-bones floppy-disk-based system. Still, the Fortune (1501 Industrial Rd., San Carlos, CA 94070) is highly competitive with an attractive package and a great deal of available software.

Pixel (1 Burt Rd., Andover, MA 01810) uses a strategy similar to Plexus in boosting the performance of its 80/AP and 100/AP machines. A TMS9900 processor handles system-level I/O (input/output) and memory mapping, a 68000 microprocessor runs user programs and the Unix system itself, and intelligent peripheral controllers pick up the rest of the load. A unique twist is the use of special video terminals that are memory-mapped into the video controller memory. The screen editor software can then manipulate strings of text in this memory directly, instantaneously updating the display without the overhead of sending the data over a serial port. Regular serial ports are supported by a separate controller.

The Universe 68 from Charles River Data Systems, as noted earlier, uses an in-house Unix look-alike called UNOS. Both hardware and software have been designed for high perfor-

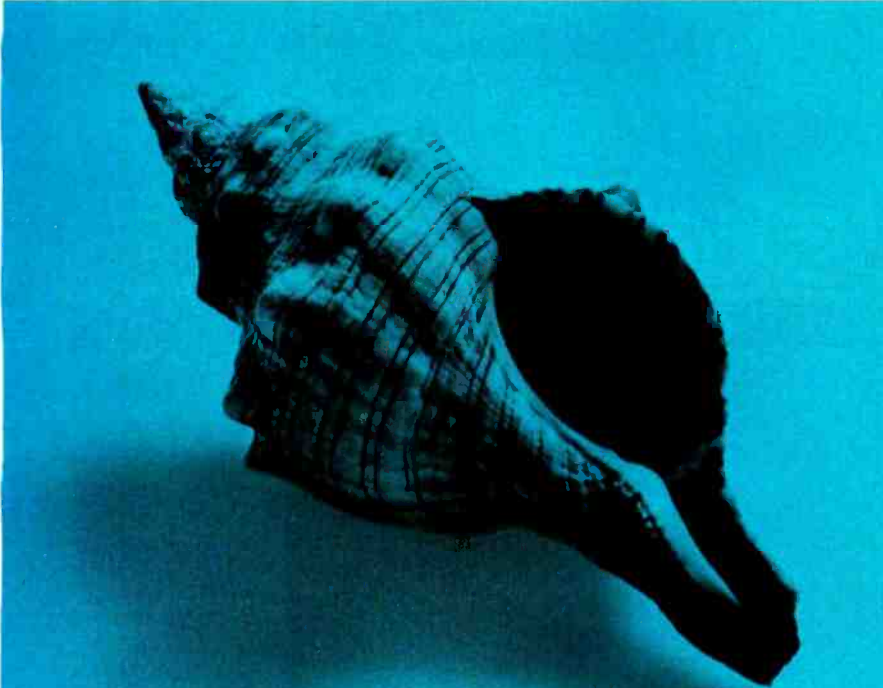

Try listening to UNIX
 That's what we do in UNIX REVIEW
 We listen, and look, and probe
 It's surprising how much there is that's fresh and new.
 Just waiting to be shared
 It's often that way with things that are simply elegant.
 Like a shell. Like UNIX

UNIX™ REVIEW
 THE MAGAZINE FOR THE UNIX COMMUNITY

UNIX is the trademark of Bell Laboratories, Inc.
 UNIX REVIEW is not affiliated with or sponsored by Bell Laboratories.

UNIX REVIEW is offered by the publishers of CP/M Review

UNIX REVIEW —\$23/year bi-monthly CP/M REVIEW —\$18/year bi-monthly

Name _____

Address _____

MasterCard or Visa No. _____ Exp. Date _____

Business Office (206) 232-6719 Editorial Office (201) 625-1797

MAIL TO: REVIEW PUBLICATION, 2711 76th Ave. S.E., Mercer Is., WA 98040

EROS

'Dedicated to Your Satisfaction!'

**LOW, LOW PRICES!
GREAT SERVICE!**

What more can you ask for!



PERIPHERALS FOR ALL COMPUTERS

PRINTERS:

STAR MICRONICS:

GEMINI 10X:
The improved & updated 10 **SCALL**
GEMINI 15X **SCALL**

SMITH CORONA:

TPI **SCALL**

C.I.TOH:

Prowriter I \$ 369.00
Prowriter II \$ 689.00
F-10 Starwriter \$1150.00
F-10 Printmaster **SCALL**

JUKI:

The New! L/Q Printer
18CPS \$ 539.00

OKIDATA:

Microline 92 \$ 499.00
Microline 93 \$ 849.00

CALL FOR PACEMARK PRICES!

HARD DISK DRIVES:

DAVONG:

(IBM, Apple)
5MB \$1339.00
10MB \$1739.00
15MB \$2139.00

TANDON:

TM-100-2 \$235.00

DISK DRIVES:

Fourth Dimension:

With Controller \$270.00
Without Controller \$220.00

Rana Series:

Elite I **SCALL**
Elite II **SCALL**
Elite III **SCALL**

DISKS:

Kangaroo: With library case
and 10 year warranty!

5 1/4" SS/DD (Box of 10) \$19.50
5 1/4" DS/DD (Box of 10) \$28.50
5 1/4" SS/DD (Box of 6) \$14.50
5 1/4" DS/DD (Box of 6) \$22.50

Verbatim:

5 1/4" SS/DD (Box of 10) \$20.95
5 1/4" DS/DD (Box of 10) \$29.95

Dysan:

5 1/4" SS/DD (Box of 10) \$30.95
5 1/4" DS/DD (Box of 10) \$38.95

MONITORS:

Amdek:

Color I \$299.00
Color II \$499.00
310G Green \$179.00
300A Amber \$179.00
300G Green \$144.00
Taxan: Amber 12" \$144.00
Princeton Graphics System:
RGB Hi-Res . \$Priced too low!
Zenith: ZVM 121 Green . \$ 99.00

MODEMS:

Hayes:

Micromodem II
with terminal program ... **SCALL**
without terminal program . **SCALL**
Smartmodem
300 Baud \$209.00
1200 Baud \$509.00

Novation:

J-Cat \$119.00
AppleCat II \$279.00
SmartCat 1200 Baud **SCALL**

U.S. Robotics:

Password **SCALL**

OTHER COMPUTERS WE ALSO STOCK:

Franklin ACE 1000/1200 Commodore 64K

Call for IBM PC and Apple IIe Prices

TANTALIZING SPECIALS!

HALF TRACK:
Macro Joystick
for your Apple™
Complete metal enclosure
Professional joystick
T&G compatible
Adjustable
\$40.00

**PANASONIC
Printer KX-P1090**
Dot Matrix
Bi-Directional
MX Compatible
96 CPS
\$499.00

**COLUMBIA DATA PRODUCTS
MPC Personal Computer**

Features:
- IBM PC Compatibility - 128K Ram -
- 16 Bit Processor -
- 8 Expansion Slots 2 RS232-1 Parallel -
- Floppy and Winchester
controllers built in -

**CALL FOR PRICES ON
COLUMBIA'S NEW
PORTABLE!**

PRODUCTS FOR YOUR IBM-PC®:

MBI:

I-C—MAGIC: Programmable Graphics Screen Dump Prom Chip.. **SCALL**
Monte Carlo™ GT™ Card **SCALL**
Monte Carlo™ Quatro™ Card **SCALL**

T&G Products:

Joysticks \$39.00
Trakball \$49.00

Kraft Products:

Joysticks \$55.00
Game Paddles \$33.00

Quadram Corporation:

Quad Board: 64K **SCALL**
Microfazer **SCALL**

Maynard Electronics:

Floppy Disk Controller:
Parallel \$209.00
Serial \$239.00

SOFTWARE:

Infocom:

Zork I \$27.00
Zork II \$27.00
Zork III \$27.00
Deadline **SCALL**
Lifetree Systems:
Volkswriter **SCALL**

Continental:

Home Accountant Plus ... **SCALL**

VisiCorp:

Visidex \$179.00
Visifiles \$179.00
Visitrend/Plot \$225.00
256K Visicalc \$179.00

PRODUCTS FOR YOUR APPLE®:

MBI:

VIP Graphics Card \$119.00
Appletime Clock Card \$ 85.00

EXPANSION CARDS:

Microsoft:

16K Card \$ 79.00
CP/M Z80 Card \$259.00

Generic:

16K Card **SCALL**

Videx:

80 Column Card
with Softswitch \$269.00
Advanced Logic Systems .. **SCALL**

SOFTWARE:

Continental:

Home Accountant \$ 53.00

On-Line:

Screenwriter II \$ 85.00

Silicon Valley Systems:

Final Analysis \$134.00
Word Handler \$125.00

VisiCorp:

Visidex \$180.00
Visifiles \$180.00
Visicalc \$180.00

T&G Products:

Joysticks \$ 42.00
Game Paddles \$ 28.00

Kraft:

Joysticks \$ 49.00
Game Paddles \$ 33.00

EROS

For a Great Time, Call: 1-800-533-8987
P.O. Box 22573 • Minneapolis, MN 55422 • 1-612-535-4544

Circle 177 on inquiry card.

TERMS AND CONDITIONS: Payment: Personal checks are accepted although cashier's checks and money orders will be shipped first. VISA and Mastercard accepted—add 4% to total. **Shipping:** We calculate exact freight—for mail-in orders add 3% UPS GRD, 4% UPS BLUE - Monitors minimum \$8.00. **Delivery:** ASAP with 2-4 weeks on average. **Price List:** Features all of our up-to-date pricing. **General:** We replace or repair faulty goods at our discretion—refunds only at our discretion—no returns on software.

With BAHR-80™ You'll Never Miss The Bus!



Imagine a single board computer with all the features you need. A quiet, multilayer board that wouldn't need to be plugged into an expensive external bus.

Meet a new high-powered friend — BAHR-80™, a compact single board computer. We've put all the features on one board for greater reliability and mechanical simplicity.

Powerful BAHR-80™ features include:

- Z-80* CPU running at 5MHz
- Up to 32K of EPROMS/EEPROMS
- Up to 1 megabyte of DRAM with parity
- Flexible, mapped Memory Management system
- DMA controller
- Four serial ports, baud rates programmable (RS-232, RS-422)
- Clock Calendar Chip and CMOS RAM, battery backed up
- Counter Timer
- Floppy disk controller
- SCSI/SASI hard disk interface
- Monitor EPROM
- Runs CP/M 2.2**, CP/M Plus**, and MP/M**
- Software available to run the RAM as a disk or as a cache buffer (CP/M Plus)
- SBX expansion connectors (in case you need even more)

Substantial OEM and dealer discounts are available.

BAHR TECHNOLOGIES, INC.™ does more. We designed BAHR-80™ after years of consulting to success-oriented companies; we guided them from good ideas to finished products on the market. Today, we custom-design boards, interface systems, and software — in short, we offer unparalleled support.

We hope you have a question. Call Ken Clark today at 608-244-7080. Ask what's on board at BAHR TECHNOLOGIES, INC.™

BAHR TECHNOLOGIES, INC.™
1842 Hoffman Street
Madison, WI 53704

*Z-80 is a registered trademark of Zilog.

**CP/M, CP/M Plus, & MP/M are registered trademarks of Digital Research Corp.

mance. The computer uses Motorola's Versabus, a 32-bit bus that allows high data-transfer rates. A 4K-byte high-speed cache memory is provided so that the main 68000 processor can run at 12.5 MHz without wait states, which would not be possible otherwise. This architecture, according to the vendor, allows performance greater than that of a VAX-11/730 at a price comparable to a Micro/PDP-11.

Another high-performance machine is designed for laboratory use but could be equally well-suited to an office environment. The Masscomp MC-500 uses three 68000 processors and three separate buses internally. A separate graphics terminal with its own 68000 and 384K bytes of memory supports multiple processes with a joystick and special windowing software. Masscomp (543 Great Rd., Littleton, MA 01460) has modified Unix to add process locking and priority scheduling and added a virtual-memory support package from Berkeley. A multiple-window menu system and graph-plotting round out the package; data acquisition runs on a separate processor still. The result is one of the fastest 68000-based computers on the market.

As a generic look at Multibus-based 68000 computers, let's examine the Sun Workstation from Sun Microsystems (2550 Garcia Ave., Mountain View, CA 94043). The original Sun processor board was developed at Stanford University, while the board Sun itself uses has been further enhanced. Sun's long suit is a high-quality workstation with 1024- by 800-pixel graphics. The Multibus allows Sun to provide a wide range of peripherals, and the company's software expertise enables it to offer the Berkeley 4.2 version of Unix, which is otherwise available only for DEC's VAX series of computers. Virtual memory, an optical mouse, multiple screen windows, and Ethernet support options enable a user to set up one Sun or a dozen with equal ease.

What do I mean by "generic"? Sun licenses its processor board design to a number of different manufacturers,

Instant one-button color printing.



Press here.

It's just that easy! Any time you want to print what's on your Apple's screen just hit the copy button on your Transtar 315 color printer with our PICS card installed, and it's done! No special programming, no lengthy code sequences, no need to exit your program! Just press the button and it prints!

By adding the optional PICS card to your \$599 Transtar 315 color printer, you've opened up a whole new world of easy color printing. For the first time ever, our PICS parallel interface card enables you to screendump virtually any program -- graphics, charts, games -- even copy-protected software! Specially designed only for the Apple II, II+, IIe, and Franklin computers, the Transtar 315 PICS card does the work of a parallel card and a lot more and costs only \$119.95.

At the push of a button, Transtar's innovative new 4-color diagonal ribbon will print up to 7 colors and more than 30 shades in a single pass.

The 315 is precision-built to exacting standards by Seikosha, the most experienced company of the famous Seiko group-- recognized worldwide for quality and dependability. In fact, one of the nicest things about Transtar's 6-month warranty on parts and labor is that you'll probably never use it!

Innovative, inexpensive, dependable, easy: the Transtar 315. Color printing has never looked so good!

Only \$599.

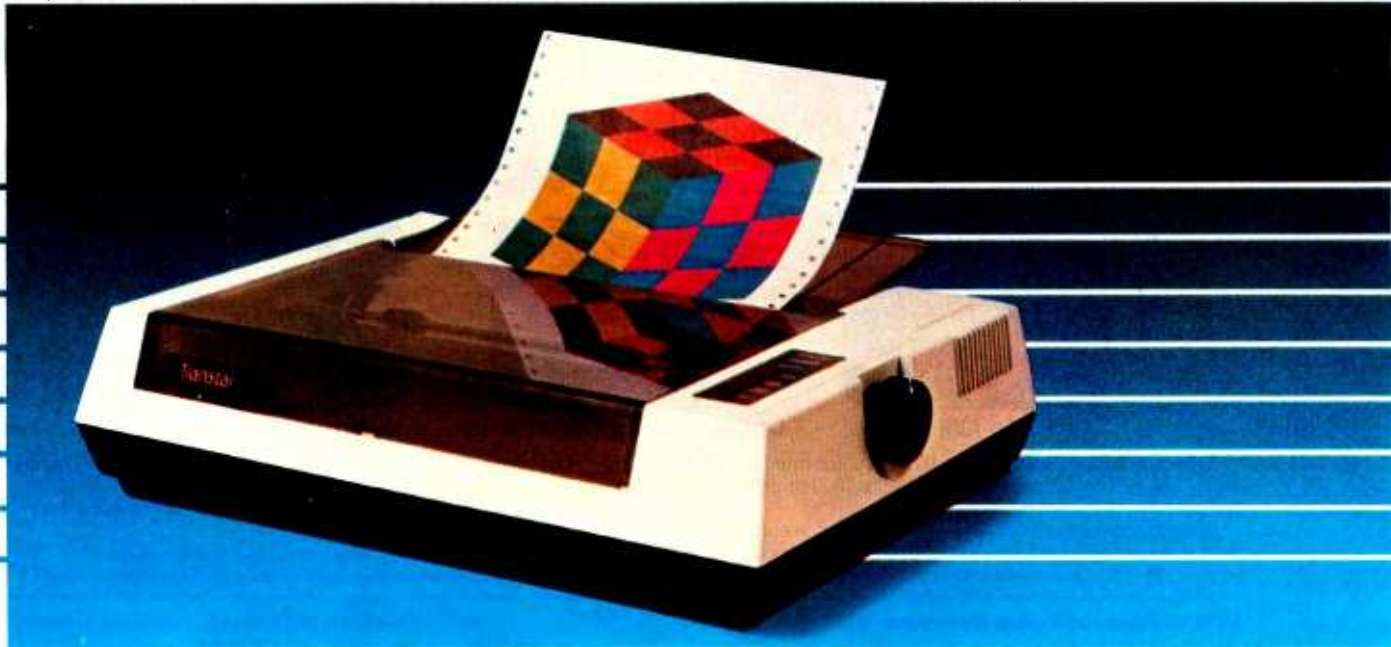

*PICS cards are currently available for Apples and Franklins.
PICS cards for other computers will be available in the future.

Transtar
A Vivitar Computer Product

P.O. Box C-96975, Bellevue, WA 98009

who generally go to Unisoft Systems for their Unix license and then to any maker of Multibus peripheral and memory boards. As a result, quite a few 68000/Multibus/Sun-board/Uni-plus+ systems are available, each appealing to different market needs. While selecting between these systems can be confusing, ultimately it protects the consumer in the event of a market shakeout—if one vendor goes out of business, its surviving competitors can probably support its customers.

The Intel 8086 Processor

As I explained above, 8086 implementations of Unix have been delayed due to hardware considerations. Altos (2641 Orchard Park Way, San Jose, CA 95134) is the chief supplier of 8086-based Xenix machines. Its ACS8600 computer is configured around the Multibus, while its newer 586 computer is based on a single board and is small, inexpensive, and powerful. For around \$8000, it provides up to six users with the power of a 10-MHz 8086 and 10-megabyte

hard disk. Intel's own Unix system is aimed primarily at OEMs and built around the Multibus, so future 80286 microprocessor boards can be easily integrated.

Any mention of the 8086 would be incomplete without a reminder that the hundreds of thousands of IBM Personal Computers and its clones represent the largest potential market for Unix-like software. The IBM PC is based on the 8088, which is internally like the 8086.

Other Implementations

While the 8086, 68000, and Z8000 are the current "big three" in the microprocessor world, other popular single-chip processors can run Unix. The next generation of microprocessor chips includes the National Semiconductor 16032 and Intel 80286, both of which will be supported by AT&T with Unix System V. BYTE has presented in-depth technical coverage of these processors already, so I will only mention in passing that the specifications of the 16032 and 80286 are comparable to several cabinets'

worth of mainframe hardware. HCR and National Semiconductor have both demonstrated working Unix systems based on the 16032. Intel is already demonstrating Unix for the 80286.

Other computers are available that use proprietary microprocessors. For example, the DEC PDP-11/23 processor can be found in both traditional minicomputer environments and in DEC's new Micro/PDP-11. The Micro/PDP-11 is housed in a thin cabinet (see photo 1 on page 133) with a 10-megabyte hard disk, floppy-disk backup, 256K bytes of RAM, and two serial ports, all for \$9200. While these specifications are not unusual compared to some of the 68000-based systems, they are notable because they provide the Micro/PDP-11 user with upward compatibility through the PDP-11 line all the way up to the PDP-11/70. This can be an important consideration for an end user or OEM, especially because most software written to run on the Unix system (particularly public-domain software) was originally writ-

16 Colorful reasons to get doublestuff™

HI-RES



DOUBLE HI-RES



actual doublestuff™ reproduction



LO-RES



DOUBLE LO-RES CONDENSED



DOUBLE LO-RES

Software Development Inc. now offers you something that Apple never told you was possible in the IIe. It's called DOUBLESTUFF.™

Using standard Applesoft BASIC commands, in combination with your existing programs, you can expand your color graphics from 16 color Lo-Res (40 x 48) to double Lo-Res (80 x 48).

Unheard of before! Available NOW! With BASIC commands. Double Hi-Res 16 colors (560 x 192 pixels) is all yours on your Apple IIe. It literally doubles the width on your standard color TV or monitor.

Requirements: Apple IIe—either 80 column card for double Lo-Resolution. Extended 80 column card for double Hi-Resolution.

NEW Products available November '83:
doublestuff designer,™ my first coloring book.™

Software

DEVELOPMENT INC.

Apple and Apple logo are trademarks of Apple Computer Inc. Doublestuff™ is a trademark of Software Development Inc.

doublestuff

designed by:

Louis Bonfiglio and Peter Joselow

To order, send check or money order in the amount of \$39.95

New York State residents, add sales tax to:

Software Development Inc.

2053 West 11th Street

Brooklyn, NY 11223 Tel. (212) 449-6300

Dealer inquiries invited.

“What more can I do?”



Your computer can probably do more for you than you originally thought. And learning to expand its capabilities is as easy as reading a good book.

SYBEX is the pioneer of computer book publishing, offering over 60 titles developed for beginners through advanced. They are so well written and easy to understand that virtually anyone can learn to operate a computer in a matter of hours.



grams and use powerful Pascal language. **Your First BASIC Program** by Rodney Zaks (\$9.95) Write your first BASIC program in one hour! At last, a “how-to-program” book for the first-time computer user, aged 8 to 88. Colorful illustrations and simple diagrams make this book both easy and entertaining.

Mastering CP/M by Alan R. Miller (\$16.95) Now you can use CP/M* to do more than just copy files. With this book you will learn how to incorporate additional peripherals with your system, use console I/O, use the file control block and much more. Also included is a library of useful macros.

The Apple® Connection by James W. Coffron (\$12.95) Now

you can learn the simple techniques for putting your computer to work controlling external non-computer devices in your home or office. Design a computer-controlled burglar

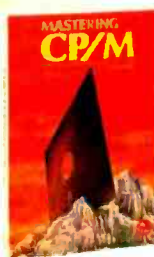

alarm system and control lights, electricity, and other non-computer devices in your home or office. And all are explained in simple, non-technical terms.

SYBEX books are available at bookstores and computer stores everywhere. For a free catalog, mail the coupon or call TOLL-FREE 800/227-2346.

Prices subject to change without notice.



Doing Business with Pascal by Douglas Hergert and Richard Hergert (\$17.95) The first of its kind, this book uses examples and explains how to: design business systems in Pascal, write practical business pro-

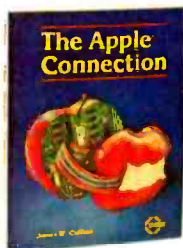

Send me: A free catalog
 0-091 *Doing Business with Pascal* \$17.95
 0-092 *Your First BASIC Program* \$9.95
 0-068 *Mastering CP/M** \$16.95
 0-085 *The Apple® Connection* \$12.95
 Add: \$2.00/Book UPS 6½% Sales Tax CA Res.
 \$12.00/Book Overseas Mail

Charge my:
 VISA MasterCard American Express
 Card # _____ Exp. Date _____
 Total Amount Enclosed \$ _____
 Signature _____
 Name _____
 Address _____
 City/State/Zip _____
 Mail to: SYBEX Inc., 2344 Sixth St., Berkeley, CA 94710
 © 1983 SYBEX, Inc. 1A 11





“Why on Earth would you want any other compiler?”

C86 - For Professional Programmers

Complete C Tight Code No Royalties Library Source

- **C - The Language for Professional Programmers:** C combines full control of the machine with the best productivity features. C is used by:
IBM Bell VisiCorp Digital Research MicroPro Wang Microsoft
- **A Complete Implementation -** C86 includes all of the features described by Kernigan and Ritchie. C86 delivers portability, consistency, FULL C.
- **Extensions** include long identifiers and additional data types.
- **Tight code is produced** by C86. Only needed code is linked from the library. The January 1983 Byte benchmark shows C86 as the fastest.
- **No Royalties** are payable to us on C programs you sell.
- **Library Source** provided includes UNIX I/O support, interface with and control of the Operating System and of hardware, all functions described in K & R, a Mathematics Library, and a Trigonometry Library.
- **Overlay Support** allows development of large programs.
- **Assembler** may be used to write a function. **Macro support** can increase productivity. Programs are **ROMable**.
- **Our Update Policy** helps you to keep the **Best Personal Computer C Compiler** for the 8086 as the technology improves.

See your Dealer for:

- Free Information: "C86 Product Description"..... NC
- "The C Programming Language" by K & R.....\$ 25.00
- "The C86 User Manual"..... 35.00
- C86 Compiler Diskette and Manual 395.00

We support all **common formats** under PC-DOS, CPM-86, MSDOS and MPM-86.

VISA and Master Card accepted. They Say It All... We Do It ALL



Computer Innovations
10 Mechanic Street
Suite J-104
Redbank, NJ 07701
201-530-0995



C86 is a trademark of Computer Innovations, Inc. CPM-86 and MPM-86 are trademarks of Digital Research. MSDOS is a trademark of Microsoft. PCDOS is a trademark of International Business Machines.

Prices subject to change without notice.

ten for the PDP-11.

Hewlett-Packard has its own implementation of Unix running on its HP-9000, which superficially resembles an Apple except that it has three-dimensional color graphics, runs like a VAX, and costs over \$64,000. Three Rivers Computer's Perq workstation supports an HCR-transported Unix with multiple windows and extremely high-resolution graphics.

Larger Unix Hosts

The PDP-11s have long been used at Bell Laboratories for software development, engineering, and office automation under Unix. Use of both Unix and the PDP-11 spread to the Bell Operating Companies for the business applications necessary to run the Bell System. The top of the PDP-11 line, the PDP-11/70 minicomputer, requires several 6-foot-tall racks of equipment; this machine is rapidly becoming obsolete due to the newer additions to the VAX line as well as the more powerful microcomputers.

The VAX is currently DEC's most powerful line of computers. A true 32-bit machine with virtual addressing capabilities, the VAX has also become pervasive in the Unix world. Specific versions of Unix have been written to take advantage of VAX architecture: Berkeley's 4.2 BSD and a previous offering from AT&T known as Unix 32V. Other firms, such as HCR with its Unity system, have made Unix facilities available to users of Unix-based software "on top of" DEC's own operating system for the VAX, known as VMS.

The first non-DEC machine Unix was transported to was an Interdata 8/32. Interdata was replaced by Perkin-Elmer (2 Crescent Place, Oceanport, NJ 07757), the first mini-computer manufacturer to support Unix. This firm's most recent line of machines, the 3210 series, comprises fast 32-bit computers of file-cabinet size with prices comparable to high-end microcomputers (in the \$50,000 range).

For those with budgets in the \$300,000 range, Gould S.E.L. (POB 9148, Ft. Lauderdale, FL 33310) has its

Let's Talk GrafTalk™

GrafTalk is business graphics software that works as hard for your business as you do.

You can use GrafTalk the way you'd like

GrafTalk is flexible in accepting commands. You can type English-language commands interactively, run commands from disk files, or use GrafTalk's menus if you prefer.

GrafTalk has all the graphics features you need

Choose from stacked, percentage, clustered, or floating bars; exploded pies, line plots, scatter diagrams and combinations plots. And adjust their style to fit your needs.

GrafTalk has lots of extras

These include a built-in text editor, a mini-spread-sheet, a feature for creating your own menus, the ability to save and edit your graphs and the capacity to interface with many other programs.

GrafTalk has good, clear documentation

With our color tutorial and full Reference Manual, you can begin making useful graphs right away.

Chances are it works with the hardware you want

GrafTalk runs on CP/M systems, the IBM-PC and other 16 bit systems and with so many screens, plotters and printers that we don't have room to list them all.

Call or write to put GrafTalk to work for you.

GrafTalk is a trademark of Redding Group Inc. CP/M is a registered trademark of Digital Research.

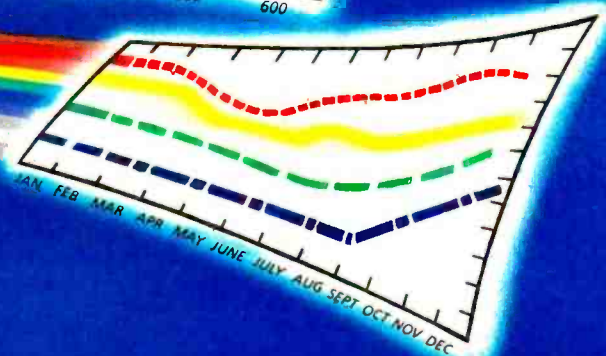
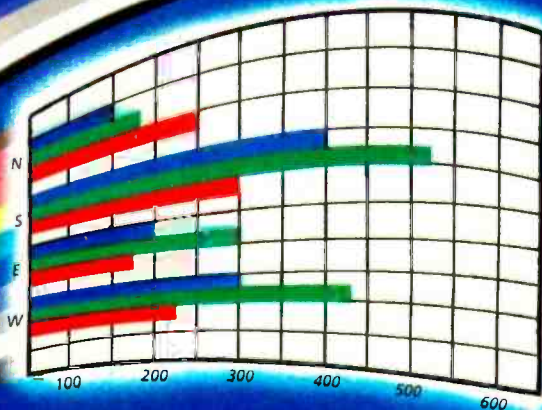
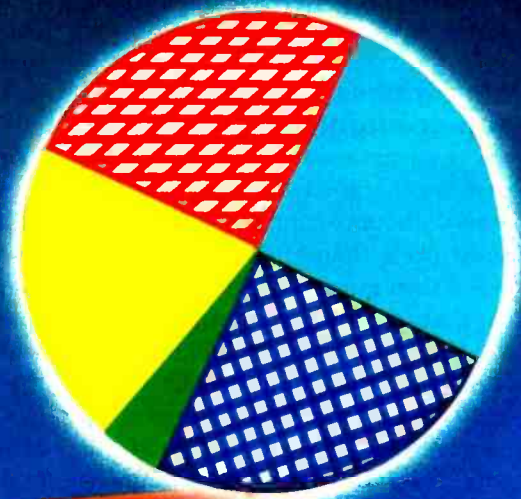

 **REDDING GROUP**

609 Main Street, Ridgefield, CT 06877 Telex 643351
2730 High Ridge Rd, Stamford, CT 06903 203/329-8874

Concept 32/87 series. At this writing, these are the most powerful computers running Unix with full factory support. Gould is rapidly becoming an important factor in Unix circles due to its commitment to Unix and wide-ranging product line.

Last but not least in the minicomputer world, we have the IBM Series 1. While this is the first computer IBM has offered with Unix support, it surely won't be the last. Apart from its Personal Computer, IBM is expected to supply its 4300 mainframe series with Unix as well.

Mainframes and Supercomputers

The customers for this class of machines generally want operating systems with more controls, checks, and audit trails than Unix has: it's rare that a firm buys a mainframe just to support software development. Even so, Unix has been available on the famous IBM/370 computers for years, although not from IBM, and not commercially; Bell Labs transported it a while back to explore the ramifica-

tions of running Unix on these behemoths. Amdahl, the maker of the original IBM look-alikes, announced in 1981 that it would support Unix on its System 470 series.

Any other mainframe Unix implementations are for now at the rumor stage only. Current rumors include not only the IBM 4300 series but also the next version of the Cray supercomputer—without doubt the world's fastest. While these developments are indeed likely to occur, they point up a certain controversy: should every computer everywhere really run Unix? Is it necessary, desirable, and even possible?

Competition from Other Systems

Unix, if it is to be considered a candidate for the "universal" operating system, should be compared with every operating system on every computer. In the interest of brevity I will limit the discussion to some of the most popular of today's operating systems for microcomputers. Minicomputers and mainframes are in many cases capable of supporting

several operating systems simultaneously; nevertheless, these larger machines are more likely to use the manufacturer's own operating system because of the larger installed base of software.

In the first article of this series, I examined the CP/M operating system and mentioned that it was limited to 8080-compatible processors. While this is true for the most widely used version of CP/M (CP/M 2.2, also called CP/M-80), Digital Research Inc., the creator of CP/M, has also been selling versions of CP/M that will run on other processors: CP/M-86, CP/M-8000, and CP/M-68000. The user interface for these versions is similar, but it is not always possible to simply recompile all your programs written for CP/M-80. This is because fewer high-level language compilers are available for the 16-bit versions of CP/M, limiting the portability of applications programs.

CP/M was not designed as a portable operating system (although it was written in the high-level language PL/M, oddly enough), so the

GRAPHICS-PLUS an enhancement For Z19 Terminals from Northwest Digital Systems

- Tektronix² 4010 Compatible Graphics
- 512 Horiz by 250 Vert Resolution
- 80/132 Col and 24/49 Line Text Displays
- Seven Page Off-Screen Text Memory
- Menu-driven "Plain English" Set-up Mode
- 16 Programmable Keys- 128 Chars Each
- Optional Hardcopy Port
- Simple Field Installation

1 TM Zenith
2 TM Tektronix
3 TM DEC

GP-19 Upgrade for Z19 Terminal	\$ 849
Z19 Terminal With GP-19 Installed	\$ 1495

Northwest Digital Systems

P.O. Box 15288, Seattle, WA 98115 (206) 362-6937

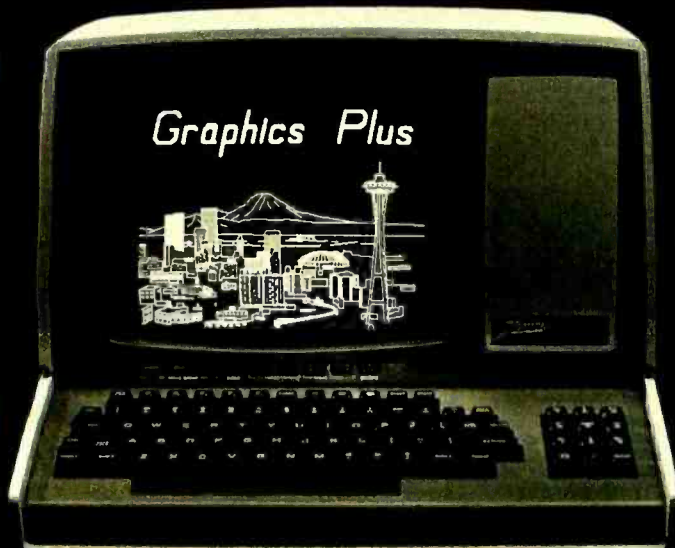

GRAPHICS-PLUS is a field installable enhancement board for the popular Zenith¹ Z19 video terminal adding many powerful features found only on terminals costing much more. GRAPHICS-PLUS provides Tektronix² 4010 compatible vector drawing graphics, VT100³ compatible 80 and 132 column display formats, off-screen scrolling memory, programmable function keys, "Plain English" menu-driven Set-up mode, and a host of other enhancements. Installation can be accomplished within 15 minutes using only a screwdriver.

Before you bet your software business on an OS, look who's betting on MS-DOS and XENIX.

A waiting market. If you write and sell 16-bit software, MS-DOS and XENIX give you the largest installed base. In fact, over fifty 16-bit manufacturers offer their microcomputers with MS-DOS or XENIX. IBM, Victor, Altos, Wang, Radio Shack, Zenith and Intel, to name just a few. And the list is growing. That means there's a ready and expanding market for your 16-bit applications software.

The UNIX™ connection. XENIX is the multi-user, multi-tasking, UNIX-derived operating system for 16-bit microcomputers. MS-DOS 2.0 is Microsoft's single-user OS. MS-DOS and XENIX share hierarchical file structure and I/O redirection, including simple piping. MS-DOS 2.0 also provides XENIX-compatible system calls. That means there's a migration path for programs written to run under MS-DOS and XENIX. What's more, both MS-DOS and XENIX are supported by Microsoft® languages. That's your single-supplier advantage from Microsoft.

Comprehensive support. Microsoft offers you a full product support program. Excellent documentation. Plus continual enhancements to both languages and operating systems. Your applications programs can even be listed in Microsoft's growing Source Directory of 16-bit applications packages. Contact us for current software offerings and vendors.

Leadership. Microsoft led the world into the 8-bit microcomputer marketplace

with the first BASIC for microcomputers. Now, we're leading it into the 16-bit market with single and multi-user operating systems.

Bet the winner. If you're writing and marketing software in the 16-bit marketplace, MS-DOS and XENIX are setting the standard. In fact, they're the standard operating systems for the world's largest selling 16-bit microcomputer systems. Which means your market is already there... and growing. Contact us for complete information. Before you bet your software on an operating system, look where your market is betting.

BETTER TOOLS FOR MICROCOMPUTERS

MICROSOFT™

MICROSOFT CORPORATION
10700 NORTHUP WAY
BELLEVUE, WASHINGTON 98004

Microsoft is a registered trademark and MS, XENIX and the Microsoft logo are trademarks of Microsoft Corporation. UNIX is a trademark of Bell Laboratories



WAREHOUSE SOFTWARE

TOLL FREE ORDER — 1-800-421-3135
 TECHNICAL INFO — (602) 842-1133

Call for programs not listed. We will try to beat any legitimate price for Software.

— **MOST DISK FORMATS AVAILABLE** —
 CP/M Program names prefaced with # are also available for IBM PC.

DATA BASE MANAGEMENT SYSTEMS.

BUY OF THE YEAR!

DBASEII+Everymans data base primer
 * Extra diskette with DBase Accounting, Mail List and Inventory Programs. IBM PC and CP/M — Call for our special price.
 Fox and Geller Quickcode with DBase Package **\$175**

#DB+SORT **\$99**
 #Condor III **\$445**
 #NWA Statpack **\$349**
 #TIM **\$285**
 #Infostar Call

WORD-PROCESSING PACKAGES

#Wordstar, Mail Merge, Spellstar Call
 #Wordstar **\$265**
 #Mail Merge **\$135**
 #Spell Star **\$145**
 #Lexisoft Spellbinder **\$270**
 #IBM PC Volkswriter **\$115**
 #Aspen Spellchecker **\$36**
 #Metasoft Benchmark **\$285**
 #Sorcim Spellguard **\$135**
 Peachtext **\$285**

SPREADSHEETS

#Calstar **\$95**
 #Supercalc **\$185**
 #Microsoft Multiplan **\$185**

ACCOUNTING

#TCS*Equivalent of Peachtree* Specially Augmented By Warehouse Software Customized For Your IBM* Terminal and Printer-GL, AR, PA, AP Each Module **\$75**
 For All Four **\$275**

#CYMA Call
 #Peachtree GL, AR, AP **\$285**
 Home Accountant Howardsoft **\$115**

TRANSFER PROGRAMS

Move-It for IBM PC **\$105**
 Hayes Smartcom Program **\$80**

Best Price in U.S.

Seven Function Board—Includes Async Adapter, Parallel Adapter, Clock with Battery Back-Up and Software, Game Port, 64K Memory Expandable to 512K.
 1 year warranty **\$2??**

CORONA computer Call
 Hayes 1200B Modem **\$450**
 Floppy Disk Controller w/Par. or Serial Port **\$235**
 S/S D/D Diskettes **\$20**
 Plantronics Color + Board Call
 MPI 320K D/S D/D Drives Call
 Toshiba 1/2 height drives Call
 64 K Ram Board Expandable 256K **\$150**
 Stediwatt Surge Protectors **\$65**
 10 Meg Datamac Drives **\$1750**

!!!!!! MONEY BACK GUARANTEE !!!!!!!

For the IBM PC—Fifty Six Utility Programs including: Label Program—Check Reconciliation—Numeric Conversion—IBM & EPSON Printer Set—Calculator Program—Interest Computation—Function Key Set—Menu Generation—Plus 47 others all for **\$19.95 post paid** — (requires 360K drives —160K drive version with 40 programs only **\$14.95 post paid**).

PCDOS

MS C Compiler **\$365**
 MS Pascal Compiler **\$285**
 Prokey **\$65**
 Norton Utilities **\$65**
 PCII Copy Program **\$34**
 Datamost Write-ON **\$94**
 Real Estate Investment Prog. **\$94**
 Microsoft Flight Simulator **\$38**
 Howard Real Estate Analyzer II **\$185**
 CP/M 86 for IBM PC **\$49**
 CBasic 86 **\$145**
 CIS Cobol 86 **\$595**
 Paicalc MT+86 W/Spp **\$450**

TERMS: Prices include 3% cash discount. Add 3% for charge orders. Shipping on most items \$5.00
 AZ orders +5% sales tax. Prices subject to change.

WAREHOUSE SOFTWARE
 4935 West Glendale Ave., Suite 12
 Glendale, AZ 85301

transported versions lack the universality that originally made CP/M so popular. Also, CP/M is a single-user, single-tasking system with relatively few built-in system utilities. In fact, many of the programs sold for use with CP/M-80 are utilities that, when added together, give that system many of the features of Unix. The only problem is that by the time you've purchased all these programs, you're short of both money and user memory. While CP/M-Plus will provide more performance for 8-bit machines, even the newer Concurrent CP/M for 16-bit processors is only a single-user system.

For these reasons, I don't expect CP/M to provide a serious challenge to Unix in those markets appropriate for Unix unless its capabilities are enhanced significantly. Even then, CP/M as a Unix-like system may find only the same limited acceptance as other Unix-like systems do today.

What of MS-DOS, Microsoft's operating system for the IBM PC that has become a de facto standard on 8086-based computers? Microsoft's plans for MS-DOS include gradual upgrades so that single-user MS-DOS will be virtually indistinguishable from single-user Xenix. A case in point is the current version of MS-DOS known as 2.0. This system has a hierarchical file structure, I/O redirection, and supports shell-like command files. Because Microsoft owns both Xenix and MS-DOS, it's a smart move on the company's part to coordinate an eventual merger.

However, this merging muddies the comparison. Clearly, if MS-DOS is to become like Xenix (and therefore like Unix), it will no longer be considered competition. MS-DOS is also limited to 8086 and 8088 processors, so let's look upon Xenix as the multi-user MS-DOS of the future and call this a battle already won by Unix.

The UCSD p-System is one of the few truly transportable operating systems on the market that doesn't resemble Unix. Sold by Softech Microsystems Inc. (16885 West Bernardo Dr., San Diego, CA 92127), the p-System's most distinctive feature is that programs written for it have close to full object code compatibility

regardless of what system they were written for. Programs don't even have to be recompiled to run on a different type of computer, as long as the p-System is supported on both machines. Currently, the p-System runs on a wide range of processors, including the 8080/Z80, 8086/8088, 6502, 6809, 68000, TMS9900, LSI-11, and PDP-11. However, the price you pay for this portability is speed.

The p-System depends on a special type of machine-independent object code called *p-code*. While p-code is the same for all machines, it has to be translated into the object code for any particular machine so it can actually execute. The catch is that this translation is done while the program is running: it's interpreted, the way most BASIC language implementations work. Also, the p-System is multitasking but not multiuser. The p-System doesn't seem to have made much of a dent in CP/M sales and shouldn't hold Unix back a whole lot, either.

There's another operating system being talked about a great deal lately that's considered by many to be new, but it was actually developed quite a while ago. Like Unix, it's both multi-user and multitasking, programmers who use it become inflamed with religious zeal, and many small computer makers are beginning to use it. It's called Pick.

Pick Computer Works of Irvine, California, licenses the Pick system on a select group of minicomputers and a growing number of high-performance microcomputers. Pick's chief strengths are that it was developed specifically with commercial applications in mind (it's essentially built around a database-management system) and that it has a strong base of applications software already in place. Pick has already proven itself a worthy competitor of Unix because it's been implemented on a few computers that don't have Unix also.

The Pick brigade is small but growing. A great deal depends, oddly enough, on the Unix software houses: if the visible output of Unix-based applications doesn't grow, word may spread that there's no software available for Unix. This would

cdex™

Training Programs

Make Using Personal Computers Easy.



Even the best application programs and personal computers still take a considerable amount of time to learn how to use. That is . . . until now!

Cdex Training Programs are computer-assisted training programs that make learning straight-forward and efficient. In an hour, you can master the material on the Cdex disks and begin using the intended product.

It's tough to learn about computers from a book. That's why all Cdex Training Programs are on disk and are:

- Highly Interactive . . .** Creating a dialogue with you and serving as your personal tutor.
- Completely Self-paced . . .** You set your own learning time.
- Graphically Oriented . . .** Remember, a picture is worth a thousand words.

Usable Now and Later . . . Clear and concise training and reference programs for the first-time or experienced user.

Cdex Training Programs run on the IBM® PC and XT Computers, COMPAQ® Portable Computer, Apple® IIe, II Plus and III Computers, DEC Rainbow® 100 Computer and Texas Instruments Professional Computer. See how effective a Cdex Training Program can be; ask your computer dealer for a demonstration.

Cdex™ Training Programs are available for:

- The VisiCalc® Program
- The WordStar™ Program
- The SuperCalc®/SuperCalc²® Programs
- The EasyWriter II™ Program
- How to Use Your IBM® Personal Computer with CP/M-86® and Concurrent CP/M-86™
- How to Use Your IBM® Personal Computer with PC DOS
- How to Use Your Apple® IIe Personal Computer
- How to Use Your Texas Instruments Professional Computer with MS DOS
- Managing Your Business with the Lotus™ 1-2-3 Program
- Managing Your Business with the MULTIPLAN™ Program
- Managing Your Business with the VisiCalc® or VisiCalc® Advanced Version Program
- Managing Your Business with the SuperCalc™ or SuperCalc²™ Program
- The dBase II™ Program
- IBM® PC DOS 2.0
- DB Master™ - Version 4
- The BPI® General Accounting Program
- IBM® Asynchronous Communications State of the Art™ General Ledger
- Peachtree General Ledger
- Making Business Decisions Using the Lotus™ 1-2-3 Program
- Making Business Decisions Using the MULTIPLAN™ Program
- Making Business Decisions Using the VisiCalc® or VisiCalc® Advanced Version Program
- Making Business Decisions Using the SuperCalc™ or SuperCalc²™ Program

Cdex™ Training Programs We make it easy.

cdex™

Cdex Corporation
5050 El Camino Real
Los Altos, CA 94022
415 964 7600

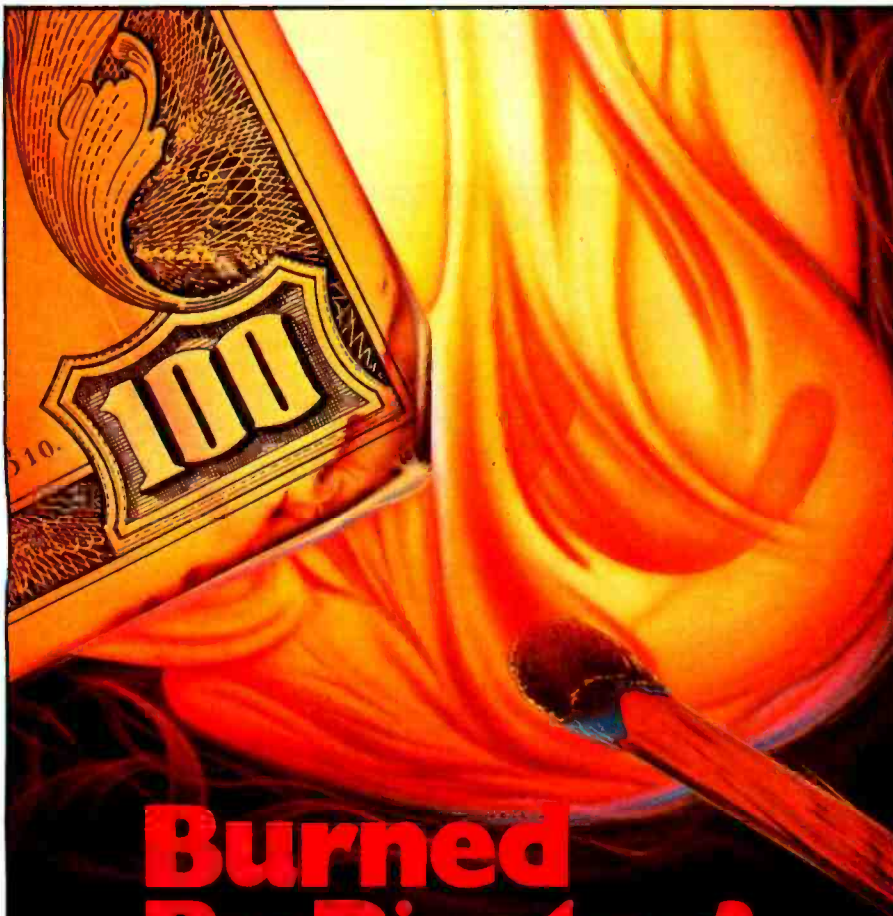

Burned By Pirates?

Don't let unauthorized copiers put a match to your profits.

The PROLOK Software Protection System is powerful, low-cost insurance against piracy.

Tough To Break

Created by a special, patent pending manufacturing process, each PROLOK Diskette is unique.

The PROLOK Protection System provides multi-level security, rendering mass by-pass schemes such as bit or nibble copiers ineffective.

Easy To Use

PROLOK Protection is invisible to the legitimate user. Back-up with normal system utilities. Protected files may be transferred to and from hard disks.

Stop your profits from going up in smoke. Call, or send \$9.95 for your PROLOK Evaluation Diskette and start protecting your bottom line.



Vault Corporation
2649 Townsgate Road, Suite 500
Westlake, CA 91361
(805) 496-6602, ext. 444

California residents, please add 6% sales tax.
PROLOK, PROLOK Software Protection Systems, PROLOK Diskette and PROLOK Evaluation Diskette are trademarks of Vault Corporation.
© 1983 Vault Corporation

cause a certain amount of disenchantment among potential Unix end users and be a boon for Pick. However, this is all just window dressing because already many more applications programs are available for Unix than for Pick. The Perchwell Corporation predicts that Pick will be the system of choice among OEMs who choose not to use Unix for proprietary reasons and that Pick will be successful in this second-fiddle role in much the same way that Oasis or Turbodos relates to CP/M.

Competition from Look-Alikes

If Unix functionality and compatibility are the only way to go, then it seems reasonable that the biggest competition for standard (i.e., AT&T) Unix will not be from other operating systems but from the look-alikes and derivatives. Here, we're talking about real money competition rather than "which operating system is better" because all these implementors tacitly agree that Unix is better.

The biggest question mark is Microsoft and its Xenix. Apart from the success Xenix has had with hardware manufacturers such as Altos and Radio Shack, the tie-in to IBM with MS-DOS means that Microsoft is in a good position to bid on any possible IBM PC contract. It's hard to predict whether IBM will support a Unix-like system on the current PC or wait for its upcoming 80286-based model. AT&T itself could have the advantage in the latter case (because it will have the rights to the "official" 80286-based Unix), so IBM could well prefer to deal with AT&T directly.

IBM has proved unpredictable before, however, and might rather go with Microsoft because it is smaller. The smallest company of all here would be Venturcom, which has the advantage that its Venix system is well thought of by IBM. In the absence of any decision by IBM, the situation would be thrown open to all the current PC-compatible systems. Of these, Unetix and Venix would most likely end up ahead: the first for its price and the second for its embedded applications and heritage.

Look-alikes in general have some of the same advantages as systems such



The
LIME™

OUR LIMES ARE HELPING THE WHITE HOUSE COMMUNICATE!

The Lime™ is a surge protector from EPD.

Surges are fluctuations on the powerline that can happen at any time, causing downtime, data loss and permanent damage to computers, software and all microprocessor controlled equipment.

Limes keep the White House Communications equipment safe from the dangers of power surges that could damage or destroy it without warning. Electronic protection devices, like TheLemon™, The Lime™, The Orange™, and The Peach™, are at work all across

the nation in places like the U.S. Justice Department, Chemical Bank of N.Y., Southwestern Bell, New England Telephone, Diebold Inc., Harvard University, and other leading organizations who know the value of expert protection.

Who's protecting your equipment from powerline problems?

Play it safe and go with the leader in surge protection that protects America's leaders. With EPD you're not only protected by the expert technology behind all of our products but by an insurance policy from Lloyds of London

that insures that protection. With EPD you're in good company.

DON'T PLUG IN WITHOUT US.



Electronic Protection Devices Inc.
P.O. Box 673, Waltham, MA 02254
(617) 891-6602 • 1-800-343-1813

as CP/M and Pick. Some manufacturers will go for these systems specifically to have something they can control a bit better (some will do it just for the price differential). Uniplus+ will continue to be popular as long as the 68000 is king; it's an easy way to get into the market.

The most important factor will be compatibility; look-alikes will survive only as long as applications software is available for them. If the differences between a look-alike and the original mean that software has to be

transported to the look-alike, it won't be worth the trouble to use the look-alike in the long run. An effort is being made among these vendors to determine a standard system interface. This should go a long way toward keeping them all in business.

An interesting factor is that AT&T's size will actually promote competition. Because it's so big, it can't possibly do everything, and if it could, it certainly couldn't do everything right for everybody. And now that people are realizing how popular

Unix is becoming, they're beginning to leave the universities, the Bell Operating Companies, and Bell Labs. They all have their own ideas on how to improve Unix and write applications for it, and you'll be seeing many new companies spring up from this "underground" base of talent.

Conclusions

We've seen that it's technically possible for just about any machine with a 16-bit processor (or larger) and a reasonable amount of disk and memory capacity to support Unix. And in spite of the other operating systems around, computer firms appear to be hedging their bets: they may support other systems, but a Unix implementation always happens to be available. It seems necessary, at least in the market for today and for the foreseeable future, for many computers to run Unix.

But do we really need Unix on every machine? Industry analysts have called for a universal user interface that would let people move to a new job without having to relearn all their computer skills. This would go a long way toward the dream of computer literacy for the masses. The rapid proliferation of Unix seems to indicate that it might be a candidate for such an honor. ■

A free, detailed set of charts listing companies mentioned in this article, their addresses, and their products, can be obtained by sending a stamped, self-addressed envelope to Unix Charts, c/o Infopro Systems, POB 33, East Hanover, NJ 07936.

References

1. Fiedler, David and Susan. *Unique: Your Independent UNIX and C Advisor*, Volume 2. East Hanover, NJ: Infopro Systems, 1982, 1983.
2. Freiboth, B. *Unix System III Guide*. El Cerrito, CA: Pacific Micro Tech, 1983.
3. McGilton, H. and R. Morgan. *Introducing the Unix System*. New York: McGraw-Hill, 1983.

David Fiedler (Infopro Systems, POB 33, East Hanover, NJ 07936) is the editor of the monthly newsletter *Unique: Your Independent UNIX and C Advisor* and the magazine *UNIX Review*. He is also an analyst for The Perchwell Corporation, a consulting firm assisting management of companies using Unix.

The Data Defenders



The Ring King™ Data Defenders. A rugged defense against grit, sharp objects, bending and all other enemies of magnetic media.

New Tray. The Ring King 070 Tray has an attached, hinged lid that locks. Built-in handles for easy moving. Inside are seven rigid dividers and room for 70 mini diskettes.

Flip File. Closed, it's a vinyl binder that protects 20 mini diskettes. Open, the cover flips up and out of the way to pre-

sent diskettes for fingertip selection.

These Data Defenders can organize and protect your data. Visit your Ring King dealer or write for our Diskette and Data Filing Systems Catalog. Ring King Visibles, Inc., 2210 Second Ave., Muscatine, Iowa 52761 (800) 533-9647, in Iowa (319) 263-8144.

**LEADERS IN
COMPUTER SUPPORT**



"Apple fest—San Francisco-booth 1151."



NOW, PLATO COURSEWARE MAKES ALGEBRA FRIENDLY.

Algebra can be a fascinating learning experience with the help of PLATO® educational courseware.

PLATO helps bring out the best in your child... and the best in your Apple II Plus or Apple IIe.

A new series of PLATO lessons can help your kids feel comfortable and confident about Algebra. Practice problems change at random to challenge them; examples of solutions guide them; performance reports encourage them. If a mistake is made, PLATO shows kids the correct answer or how to correct it. So before they know it, they're

into Roots, Polynomials, Factoring, Equations and much more.

These Elementary Algebra lessons join the growing PLATO library of quality educational



courseware for microcomputers. Other lessons include Math, Foreign Languages, Physics-Elementary Mechanics, Computer Concepts, Computer Literacy and Keyboarding.

See the PLATO line at selected retail outlets. All PLATO micro courseware is available for the Apple II Plus and Apple IIe.

Some lessons are also available for the TI99/4A and Atari 800.

For a free PLATO catalog:
Call toll-free: 800-233-3784.

(In Calif., call 800-233-3785.)

Or write Control Data Publishing Co., P.O. Box 261127, San Diego, CA, 92126.

Warranty available free from Control Data Publishing Co., 4455 Eastgate Mall, San Diego, CA 92121.

PLATO
COMPUTER-BASED EDUCATION

GD
CONTROL DATA
PUBLISHING

THE ONE COMPUTER TO HAVE WHEN YOU'RE HAVING MORE THAN ONE.



If you're considering linking up more than one computer, there's only one computer worth considering.

The British Broadcasting Corporation Microcomputer System by Acorn.

One of the BBC Micro's many built-in features is an economical and powerful communications network.

We call this the Econet® local area network.

Econet lets you combine up to 254 BBC's into a single communications system. Virtually no other system lets you hook up this

many computers this easily.

What's more, you can link two micros without any special hardware. And all computers on the Econet network can share disc drives and printers.

But what really makes Econet such a great network of computers is the computer it networks. The BBC Micro. The most versatile computer anywhere for its size and price. Its enormous built-in expansion potential means it can handle anything from basic tasks to advanced Econet networking. It also means changing technology won't change it into an obsolete

system overnight.

All of which make Acorn the perfect communications system for schools or business.

If you'd like to learn more about how Acorn can build you the perfect communications network, write Acorn Computers Corporation, 400 Unicorn Park Drive, Woburn, Massachusetts, 01801, or call toll-free 1-800-225-8001 (in Massachusetts call 617-935-1190). We'd be happy to communicate with you.

ACORN COMPUTER 
© 1983 Acorn Computers Corporation
Circle 13 on inquiry card.



Unix and the Standardization of Small Computer Systems

Developed at Bell Labs around 1970, Unix is heavily influencing the assimilation of systems and applications software

by Jean L. Yates

Small computer systems were first standardized at the hardware level, with standard microprocessors, buses, peripheral chips, and peripherals providing increasingly low-cost systems. Major hardware vendors are now working with software houses to standardize operating

systems and applications so that microcomputers and mainframes can communicate on program, file, and message levels. Within the next three years, the most commonly used type of personal computer will achieve multiprocessing capability, and the number of networks and multiuser

systems will grow dramatically. The Unix operating system and the C language will be major factors in the standardization of file handling and compatibility across small systems and mainframes.

Table 1 portrays the rapid decline in price and accompanying increase in hardware capabilities of typical small-business microcomputers over the past four years. In 1979 the Vector Graphic System B was one of the most popular small-business systems. With 56K bytes of memory, a Z80 microprocessor running CP/M, single-user capability, and 500K-byte floppy disks (very high density for its time), the system sold for \$5500.

By 1981 a new generation of computers with increased hardware capability and a corresponding higher price became popular. Onyx's 8002, for example, which could handle up to six users, offered 256K bytes of RAM (random-access read/write memory) with a Z8000 16-bit microprocessor and the Unix operating system. A tape backed up its 5- to 10-megabyte hard disk, and the system sold for \$15,000 to \$30,000, depending upon the configuration.

Today, products such as the Radio

Time of System's Popular Use	1979	1981	1983	1985
Type of Computer	Vector Graphic System B	Onyx	Altos 586	a future system
Storage Capacity (bytes)	56K	256K	512K	2 megabytes
Microprocessor Used	Z80	Z8000	8086	68010, 286, 386, or 32032
Operating System	CP/M	Unix	Xenix	a virtual type
Number of Users	1	1 to 6	1 to 6	1 to 25
Storage Media	two 500K-byte floppy disks	tape and 5 to 10 megabytes on hard disk	1 megabyte of floppy-disk backup for a 10-megabyte hard disk	a 2-megabyte backup for 50-200-megabyte hard disk
Price	\$5500	\$15,000 to \$30,000	\$8000	\$6000

Table 1: As great strides are made in improving hardware capabilities, prices of small-business computers will return to 1979 levels.

Shack TRS-80 Model 16 and the Altos 586 have radically reduced the price of Onyx-type systems. The Altos 586, which provides 512K bytes of RAM, an 8086 microprocessor, Microsoft's Xenix version of the Unix operating system, one- to six-user capability, and 1 megabyte of floppy-disk backup to a 10-megabyte hard disk, sells for about \$8000, depending upon the configuration. Table 1 points out that with \$6000, users could purchase much more computing power in 1983 than in 1979. In addition to the Altos 586, the TRS-80 Model 16, Fortune's 32:16, IBM PC-XT, and Victor 9000 are examples of systems offering high levels of hardware performance for a comparatively low price.

By 1985 a small-business micro-computer selling for \$6000 will provide 2 megabytes of memory, use a 32-bit microprocessor such as the 68010 or the 386, and offer a virtual operating system. (Today, such systems, which let you run other systems over them—as you would applications programs—are available only on 32-bit superminicomputers and mainframes.) This hypothetical 1985 system should let up to 25 users utilize a 2-megabyte floppy-disk, tape, or optical-storage backup and 50 to 200 megabytes of hard-disk storage.

Increasingly, operating systems for small-business computers are being written in higher-level programming languages such as C. These systems offer networking and other communications capabilities, hierarchical file systems, and disk sharing. Unix is often the vehicle used to take business applications from minicomputers to microcomputers. Unix and the C language are increasingly evident in standard software for 16-bit micros.

The Drive to Standards

The standardization of hardware has been clearly demonstrated, and standardization of the operating system is evident from the popularity of CP/M, MS-DOS, and Unix. These three operating systems are keys to large libraries of applications

software. Currently, the big push in standards is to connect microcomputers to minis and mainframes. Although the hardware and operating-system levels are themselves problems, the biggest problem is connecting packaged applications such as Visicalc or word processors to mainframes and allowing files to be shared and manipulated from mini- or mainframe-based data storage to micro workstations.

Licensed Unix sites will number 1.4 million by 1987.

Available for micros, minis, and mainframes, Unix becomes a viable standard for file and program compatibility.

Standardization Areas

To connect micros to mainframes, standardization must occur at several levels. Although it might initially appear that standardization should occur at the hardware-connection level, most of the standardization needed for software transfer to mainframes and across different types of micros occurs at the operating-system level.

And in many cases, Unix is the standard by which new operating-system developments are being compared.

At the operating-system level, the file format, or the way in which files are held on a floppy disk, is undergoing considerable standardization. The type and order of bits at the beginning and end of files and the way in which data is held in the file maintain, in many operating systems, the same format that Unix has historically used. Unix holds almost all data and text files in standard ASCII (American National Standard Code for Information Interchange) code and does not encode or encrypt data unless it proves absolutely necessary. Great flexibility in moving or manipulating files is thus maintained. You can observe most Unix files with a text editor and see what they contain, unlike binary or hexadecimal files, which produce only dashes and blips on the screen.

Command names, directory structures (specifically the hierarchical directory of Unix), I/O (input/output), and record locking are other areas of standardization on which Unix is having a great impact. Language (gross and subsets) syntax and function call names and arguments are other areas where the C language

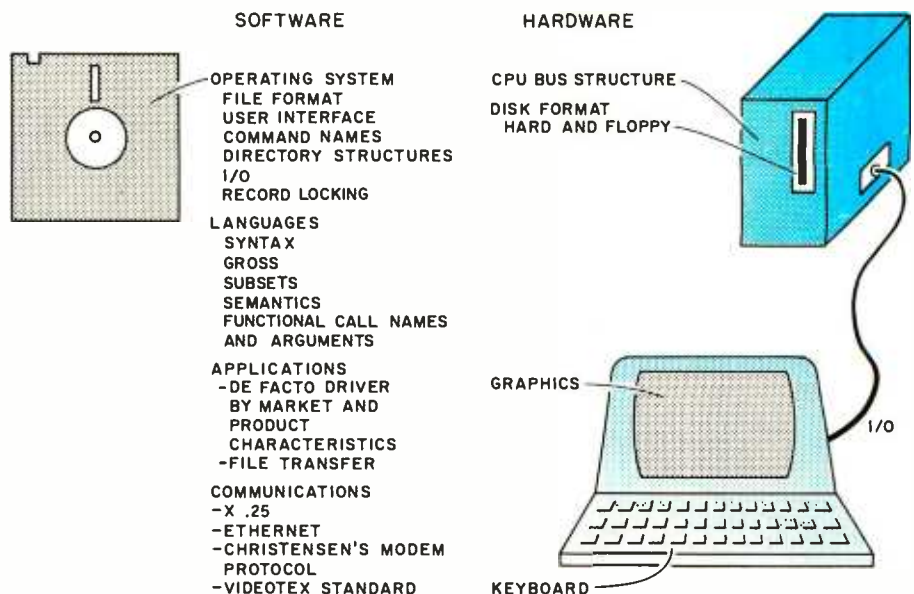

Figure 1: A look at the various areas that are experiencing standardization.

and the system calls of Unix are evolving.

At the applications-software level, drivers for terminals and disks are standardizing as vendors realize the importance of offering a standard interface for easy transfer to their computers. File transfer from micros to mainframes is also becoming standardized. A format growing in popularity is Visicorp's DIF, which has been adopted by most spreadsheet-application vendors as the standard way to hold and manipulate spreadsheet data. For more information on this data-interchange format, see "DIF: A Format for Data Exchange between Applications Programs" by Candace E. Kalish and Malinda F. Mayer (November 1981 BYTE, page 174). Some of these standards are shown in figure 1.

Standard Operating Systems

The three major families of standard operating systems are MS-DOS, CP/M, and Unix. Figure 2 shows that MS-DOS is expected to be the market leader for the next three years. CP/M-80 and CP/M-86 together match the market size of MS-DOS, and the recent Visicorp/Digital Research alliance could push CP/M-86 up near the MS-DOS level. (Visicorp and Digital Research have

Unix for Microcomputers—A History

Developed by Bell Laboratories around 1970 for use on minicomputers, the Unix operating system has evolved into a multi-user system for 16-bit business microcomputers. In contrast to the Apple II, which uses a 6502 8-bit microprocessor, or the TRS-80 Model 1, which incorporates a Z80, a 16-bit microcomputer includes such microprocessors as the 8086 or the 68000. As a multiuser system, it lets many users interact simultaneously with the computer from different terminals.

Unix is actually an operating-system chameleon; its many forms and flavors are the result of adapting research and development software to commercial uses. Today, the operating system is distributed by more than 100 computer and software ven-

dors. Some versions are specifically for use on microcomputers, and some forms of Unix have been reworked to meet the needs of such users as engineers, typesetters, and government agencies.

The majority of Unix users are microcomputer owners whose specific needs differ from those of the traditional computer user. Many find themselves confronting a multiuser operating system for the first time and are thus unfamiliar with the special software-maintenance requirements such systems involve. Because Unix was not developed for the uninstructed user, a beginner cannot take advantage of much of its computing power.

Two companies in particular are promoting the adaptation of Unix for microcom-

agreed to place Visi On, Visicorp's user interface, over Digital Research's operating systems and to provide language and tool support for each other's products.)

The number of licensed Unix installations by the end of 1986 will be only 1.4 million, although pending announcements by small-system manufacturers, specifically Commodore, could boost that figure by another million units. Although the number of Unix licenses is less than

that of MS-DOS or CP/M, those operating systems' sales figures (in dollars) are nearly equal. An average Unix-based system is a higher-performance micro or mini that can accommodate multiple users and costs more than a system running MS-DOS or CP/M.

Table 2 shows the number of new Unix licenses and the dollars that will be spent on licensed mainframes, minicomputers, and microcomputers from 1981 through 1986. The micro-

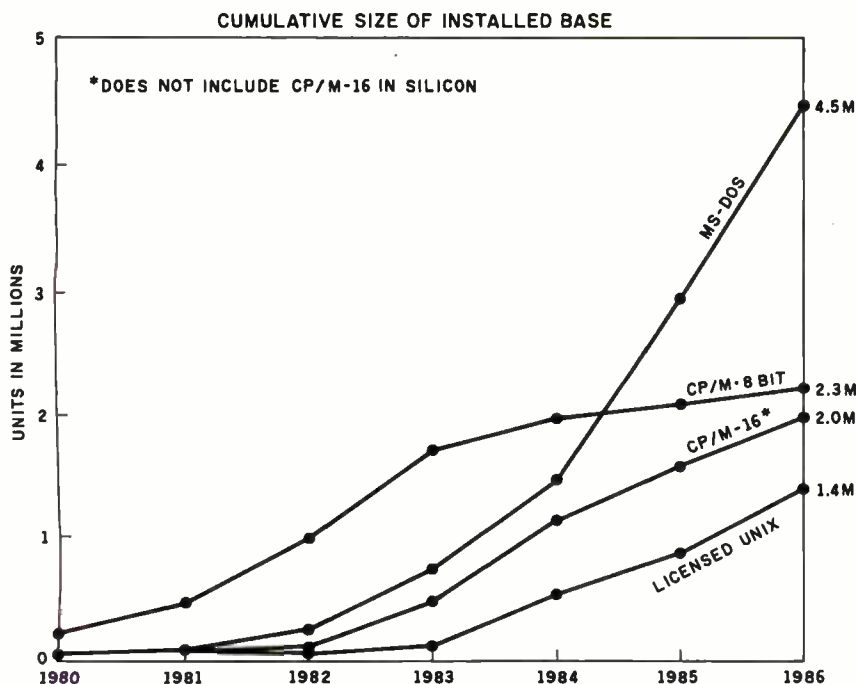

Figure 2: Projected sales of major nonproprietary operating systems through 1986.

CUMULATIVE NUMBER OF UNIX LICENSES THROUGH DECEMBER 1986

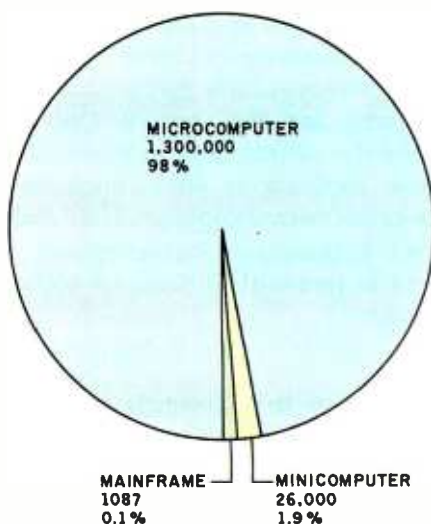

Figure 3: At the end of 1986, mainframe and minicomputer licenses for Unix will represent only 2 percent of the total number issued.

puters: Microsoft Corporation of Bellevue, Washington, with its Xenix operating system for use on 8086-, Z8000-, and 68000-based microcomputers, and Unisoft Systems of Berkeley, California, which makes a system for 68000-based microcomputers. Other vendors have brought Unix to such computers as the Onyx and Plexus.

From its origins as a software program for text editing and formatting, Unix has evolved over a decade to the point that it is now a massive set of programming tools for software development, text preparation, and communications in addition to its ability to perform operating-system functions. The developers of Unix pioneered the concept of software portability—the

capability of operating on various types of computers. This concept was introduced by the Bell System because it didn't want to have to write new software when it decided to use a new type of computer. Portability has proven to be a major selling point for Unix.

The C Language

Unix is written in the C language (see the August 1983 BYTE), which was also developed at Bell Laboratories. Machine-independent C was designed for large software programs that can be used on various types of systems; Unix derives its portability from C. Many microcomputer companies develop applications software in C, often using Unix tools, which are

specifically designed for efficient C programming.

Bell Labs has continued to enhance Unix software and releases periodic updates. With its release of System V earlier this year, Bell demonstrated support of versions for microcomputers in addition to its line of minicomputer-oriented products. Bell may decide to offer additional microcomputer and business software in the future. Today, more than 200 independent software vendors offer Unix applications packages for spreadsheet, accounting, inventory-control, and other business uses.

computer market represents the bulk of Unix units and dollars, although the minicomputer sector is by no means insignificant. Figure 3 diagrams the predicted preponderance of Unix licenses for microcomputers through December 1986; those licenses will account for 98 percent of the total issued.

The Shift to Commercial Use

From 1980 to 1986, Unix end users will change dramatically. As figure 4

indicates, Unix users in 1979 were almost entirely from research facilities and universities, the Bell System, or the government/military. At that time, commercial users made up only 3 percent of the total. By the fourth quarter of 1983, however, 93 percent of an estimated 100,000 total Unix sites will be commercial.

As the Unix market changes to meet commercial needs, it will also serve a vertical market, one that provides specialized software to such

diverse fields as banking and medicine, which implement Unix yet cannot share applications packages.

The Vertical Unix Market

Yates Ventures surveyed more than 600 companies, mostly minicomputer systems houses that sell vertical-market software packages as turnkey systems with 16- or 32-bit minicomputers. Of the companies surveyed, more than 400 have products that could run under Unix; 250 expressed an interest in or said they planned to offer their software on a Unix system.

The vertical market's potential for Unix varies from area to area. One of the largest areas is the banking industry, which is particularly interested in lower-cost fault-tolerant or nonstop systems. Fault-tolerant systems provide built-in mechanisms that work to prevent breakdowns. Tandem originally had the market for nonstop systems to itself. Such companies as Auragen, Bunker-Ramo, Parallel, and Tolerant Transaction Systems, however, are now competing with Tandem and offering much less expensive computers. These manufacturers are providing a viable alternative for those sectors purchasing nonstop systems. Many of these groups simply cannot afford the bigger Tandem systems.

Annual Distribution of New Unix Licenses							
	1981	1982	1983	1984	1985	1986	Total
On mainframes							
\$ Million	3.7	7.6	42.2	88.3	111.9	119.1	372.8
Units	9	20	115	248	325	370	1087
On minicomputers							
\$ Million	220.5	357.0	542.0	838.0	1015.0	1053.0	4025.5
Units	1310	2200	3375	5050	6710	7690	26,335
On microcomputers							
\$ Million	31.4	447.3	1588.8	3437.7	4996.1	5256.5	15,757.8
Units	1320	23,710	110,600	269,800	414,800	495,500	1,315,730
Grand total							
\$ Million	255.6	811.9	2173.0	4364.0	6123.0	6428.6	20,156.1
Units	2639	25,930	114,090	275,098	421,835	530,560	1,343,152

Table 2: Demand for Unix licenses for microcomputers will skyrocket over the next three years.

Hank: Here's the report you've been waiting for. Hope you put your system on automatic and didn't wait up.

To all reps: Price changes on following items effective immediately: No. 10-111A, 10-114A; 10-AL.

Take that, bud. (And retaliate fast. I know phone rates are low now, but game's cutting into sack time.)

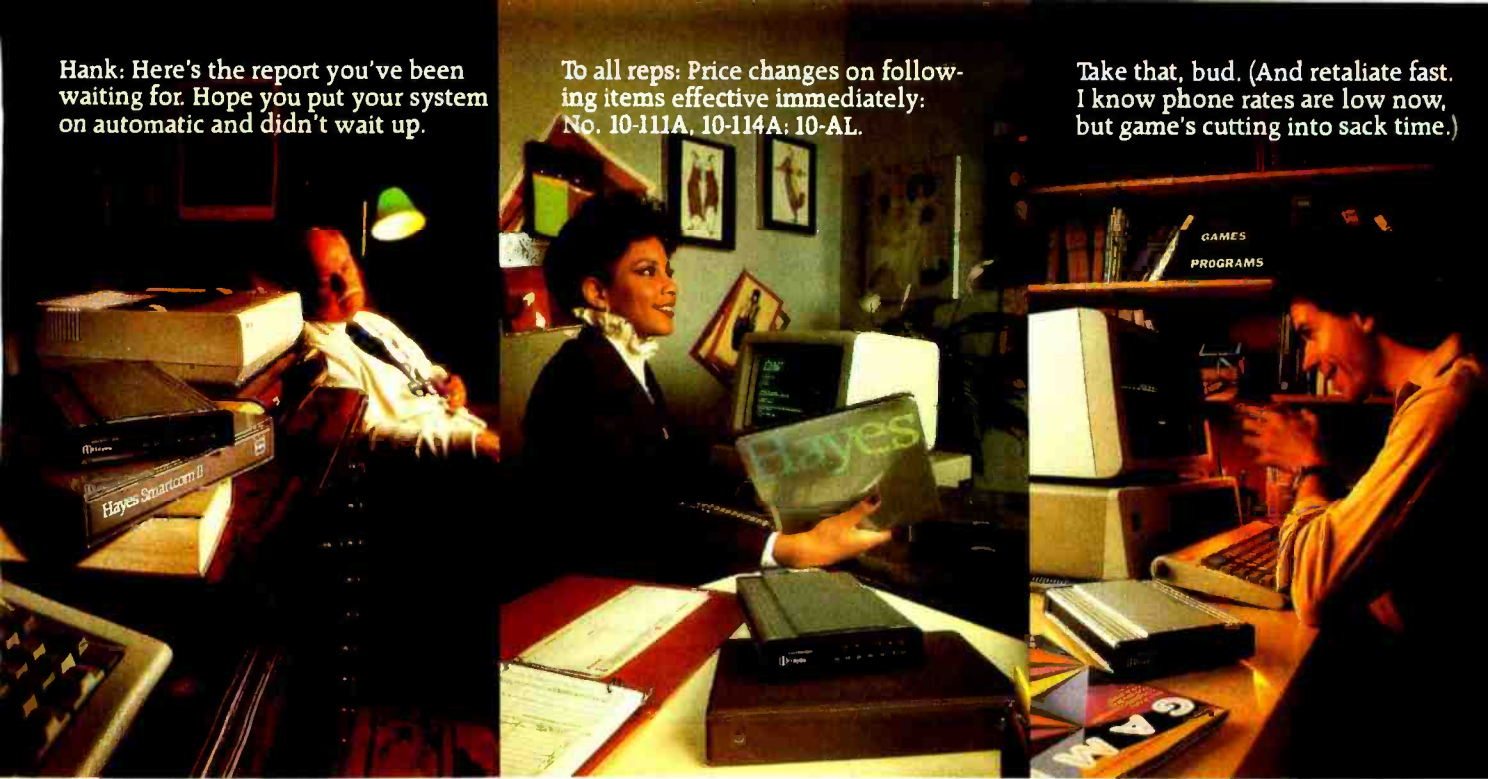

Your computer's telephone. Hayes

Wouldn't it be great if, somehow, you could connect your computer to your accountant's, down the street? To the IBM** PC at the branch office, upstate? Or to your favorite chess challenger, across country?



With a telecomputing system by Hayes, you can.

Quickly. Easily. And for the price of a phone call.

Hayes Smartmodem. Think of it as your computer's telephone. Hayes Smartmodem 300, and the faster Smartmodem 1200, work with any computer with an RS-232 I/O port. They allow you to communicate,

over ordinary phone lines, all across America.

But any modem will send and receive data.

Smartmodems also dial, answer and disconnect calls. Automatically. Without going through the telephone receiver, making them far superior to acoustic coupler modems.

Choose your speed; choose your price. The lower-priced Smartmodem 300 is ideal for local data swaps and communicates at 300 bps. For longer distance and larger volumes, Smartmodem 1200 communicates at 1200 bps or up to 300 bps, with a built-in selector that automatically detects transmission speeds.

Both work with rotary dials, Touch-Tone* and key-set systems; connect to most time sharing systems; and feature an audio speaker.

Either Smartmodem is a perfect match for many different computers. And if you have an IBM PC, Hayes also provides the perfect communications software.

Smartcom II™ We spent a lot of time developing our software, so you can spend less time using it. Smartcom II prompts you in the simple steps required to create, send, receive, display, list, name and re-name files. It even receives data completely unattended—especially helpful when you're sending work from home to office, or vice versa.

And if you need it, there's always "help." One of several special functions assigned to IBM function keys, this feature explains prompts, messages, etc. to make communicating extra easy.

With Smartcom II, it is. The program remembers communication parameters for 26 different remote systems. Just punch a key, you're all set.

You can treat dial-up and log-on sequences the same way. In fact, Smartcom II comes with codes already set up for four popular information services. **COMPU SERVE®**, **DIALOG'S KNOWLEDGE INDEX™**, **DOW JONES NEWS/RETRIEVAL SERVICE**, and **THE SOURCE™** AMERICA'S INFORMATION UTILITY.™ Procedures for obtaining an account with each of the services are included in the Smartcom II manual. But that's not all.

Special offers for Smartcom II

 **Hayes®** owners! Dow Jones News/Retrieval Service has a special introductory offer for

Smartcom II owners. By calling a toll-free number, they receive a free password and one free hour of service anytime after 6:01 p.m., local time.

You'll also be entitled to a valuable

Welcome to **TELEMAIL!** Your last access was Tuesday, Jan. 4, 1983 11:07 a.m. CHECK these bulletin boards: TELEMAIL...TELESOFT...

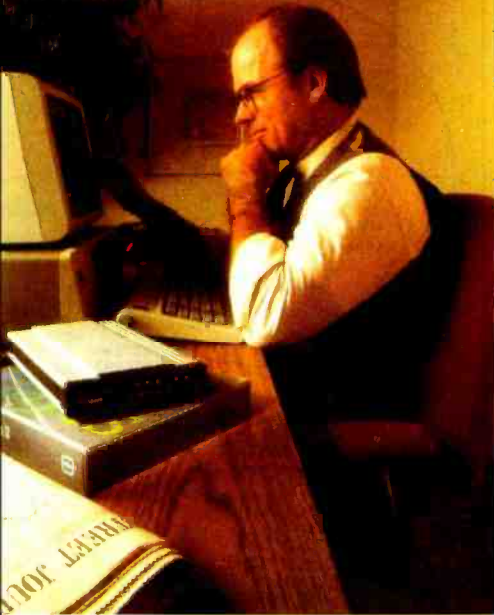

END USERS OF UNIX

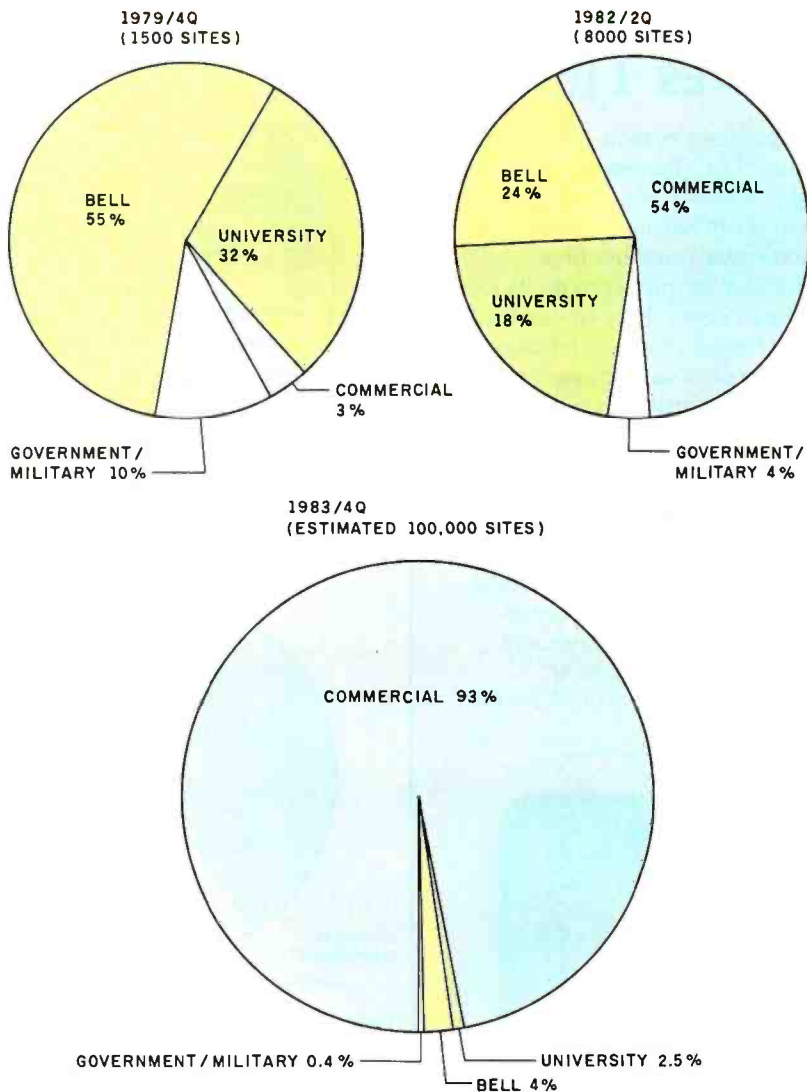

Figure 4: These pie charts show a projected shift in the type of user implementing Unix. By the end of this year, approximately 93 percent of licensed sites will be devoted to commercial applications.

The Market for Unix Applications Software

Based on marketing interviews it regularly conducts, Yates Ventures has projected what types of applications software will make up the total Unix market of \$282.6 million in 1983. Accounting and business-systems software, for example, will represent 30 percent of the Unix market. Word-processing packages will hold second place with a 25 percent share. The productivity-management sector, which includes such packages as electronic spreadsheets, will represent 15 percent. Figure 5 compares the applications-software-market breakdown for 1983 with projected figures for 1986.

By 1986 vertical-market packages will dominate a \$1.7 billion market, representing 37 percent of the total. Productivity-management packages will make up 26 percent of the overall market, with accounting and business-systems software running third at 15 percent. Figure 6 depicts the shift toward verticality—Unix applications-software vendors will see significant growth in that segment. Note, too, that in 1983 hardware vendors and applications-software developers will evenly share 80 percent of the sales of Unix applications packages. Systems integrators will represent a scant 4 percent. By 1986, however, that segment will be selling microcomputers

subscription offer for **THE SOURCE**. Smartcom II owners who subscribe to **THE SOURCE** will receive one free hour of daytime service.

Like all our products, Smartcom II and both Hayes Smartmodems are backed by excellent



documentation and full support from us to your dealer.

So see him today. Break out of isolation. Get a telephone for your desktop computer.

Hayes Microcomputer Products, Inc., 5923 Peachtree Industrial Blvd., Norcross, GA 30092. 404/449-8791. Smartcom II is a trademark of Hayes Microcomputer Products, Inc.

*TM American Telephone and Telegraph
*IBM is a registered trademark of International Business Machines Corp.

© 1983 Hayes Microcomputer Products, Inc. Sold only in the U.S.A.

COMPUSERVE INFORMATION SERVICE is a registered trademark of CompuServe, Incorporated, an H & R Block Company.

KNOWLEDGE INDEX is a service mark of DIALOG Information Services, Inc.

DOW JONES NEWS/RETRIEVAL is a registered trademark of Dow Jones & Company, Inc. THE SOURCE and AMERICA'S INFORMATION UTILITY are service marks of Source Telecomputing, a subsidiary of The Reader's Digest Association, Inc.

MicroSpooler® Saves Time

MicroSpoolers mean an end to waiting. The MicroSpooler stores data and feeds it to your printer as fast as it can handle it. You don't lose valuable computer time waiting for the printer to do its job.

Easy to install. Easy to use. Easy on the budget. These stand-alone MicroSpoolers can be installed in-line between virtually any printer and any computer.

Features:

- 16K memory (user expandable to 32K or 64K)
- Status readout
- Internal power supply
- Vertical mount configuration
- Independently selectable baud rates and handshaking
- Satisfaction guaranteed
- Priced from \$ 219.00



Send or call toll free for literature on our complete Spooler lines.

CONSOLINK CORPORATION

Dept. 2-48
1840 Industrial Circle
Longmont, CO 80501
(303) 651-2014
800-525-6705

UNIX 16-BIT APPLICATIONS-SOFTWARE MARKET SHARE (PERCENT BY NEW SALES)

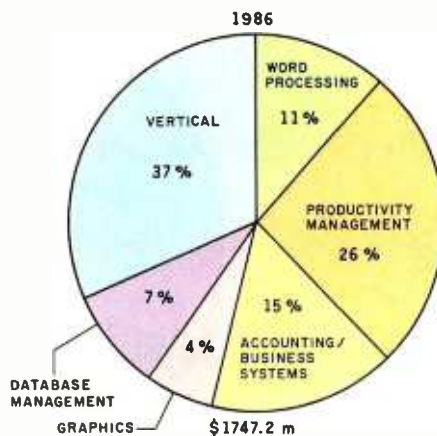
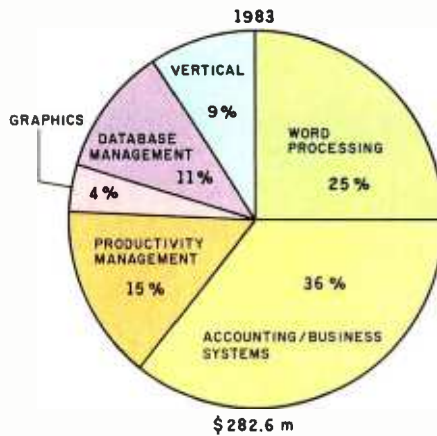

Figure 5: Applications software for Unix 16-bit systems will bring in more than \$1.7 billion in 1986.

with Unix as the standard operating system, and its turnkey system for vertical markets will bring its market share to 55 percent. Also by that time, independent third-party vendors of applications software will control 30 percent of the market while hardware vendors hold on to 10 percent.

Conclusion

The standardization of small computer systems, which began at the hardware level, has now reached operating systems and applications software aimed at the Unix market. Encouraged by the availability of Unix on microcomputers, minis, and mainframes, vendors will continue to adapt it across the spectrum of microcomputer and mainframe products. Moreover, the vertical market

APPLICATIONS-SOFTWARE VENDORS FOR UNIX

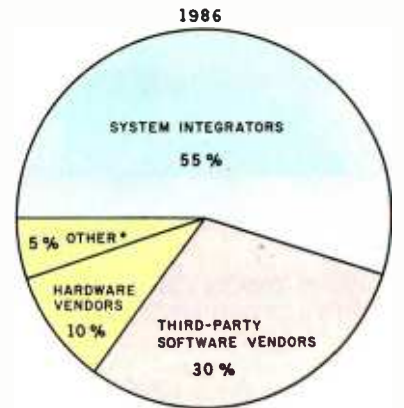
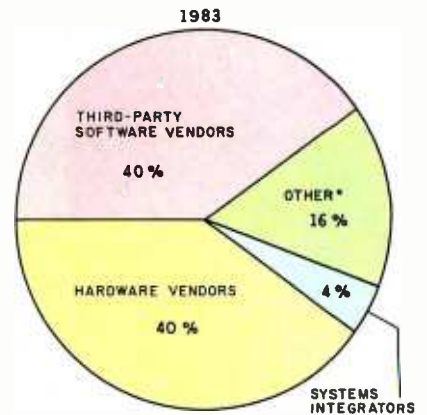

* OTHER INCLUDES INDEPENDENT CONSULTANTS, RETAIL DEALERS AND MAIL-ORDER HOUSES.

Figure 6: Turnkey systems for vertical markets will strengthen systems integrators' position among vendors of Unix applications software.

for Unix will expand. In the future, Unix microcomputers can be expected to command a large share of the microcomputer market because they are priced higher than units that run MS-DOS and CP/M. In the years ahead, those Unix-based micros will be sold largely by systems integrators that will offer vertical-market turnkey systems previously offered only on minicomputers with proprietary operating systems. ■

Jean L. Yates is president of Yates Ventures (4962 El Camino Real, Los Altos, CA 94022), a firm that conducts marketing research on Unix, publishes periodicals and books, and produces training materials on the operating system's use. Author of The User Guide to the UNIX System and Business Guide to the UNIX System, she is also a member of the National Computer Conference program committee.



Repeat it once more... "No manual tax preparation in '84"

Micro-Tax* can turn your personal computer into a profit center—you'll increase your client volume and take the drudgery out of tax preparation. And since the returns never leave your office, you have complete client security.

MICRO-TAX* IS COMPREHENSIVE. It offers three Federal tax packages and 23 fully integrated state packages, so you can select the programs that best meet your needs. Level II has a tax depreciation module, and it automatically computes underpayment penalties, self-employment taxes, minimum taxes, and income averaging. For those who prepare Federal partnership, corporate, and Subchapter S returns, Micro-Tax* has a Federal Level III package. Each tax season Micro-Tax* offers you an update package.

MICRO-TAX* IS VERSATILE. The program is compatible with your IBM PC* or XT*, DEC Rainbow*, Radio Shack*, or any other personal computer with CP/M*, PC DOS* or MS DOS*—from Apple* to Zenith*.

Instead, save yourself time and money and satisfy your clients with your personal computer and...

MICRO-TAX*



MICRO-TAX* IS FLEXIBLE. It's up to you; you can input the client tax information at the time of interview and produce the forms immediately, or enter data during the day and batch print returns at night. Micro-Tax* prints your returns on IRS forms, IRS approved substitute forms, or with transparent overlays.

MICRO-TAX* IS FRIENDLY. You can organize data entry in a sequence very similar to that of manual tax preparation, or you can compute forms out of sequence. It's up to you. So go ahead, repeat it once more...

"No manual tax preparation in '84." No need—once you've got Micro-Tax.*

Call Micro-Tax direct for complete details, or call your local dealer.*

Prove it to yourself: order a demonstration package—a complete 1982 Federal, Corporate/Partnership or State system for only \$58.00 each.

FULL FEDERAL MICRO-TAX* PERSONAL COMPUTER SYSTEMS	1983 FEDERAL FORMS AND SCHEDULES INCLUDED																							PRINTS																																																																																																																																																																																																																																																																																																																																																																																																																																																																																																																																																																																																																																																																																																																																																																																																																																																																																																																																																																																																																																																																																																																																																		
	1041	1042	1043	1044	1045	1046	1047	1048	1049	1050	1051	1052	1053	1054	1055	1056	1057	1058	1059	1060	1061	1062	1063		1064	1065	1066	1067	1068	1069	1070	1071	1072	1073	1074	1075	1076	1077	1078	1079	1080	1081	1082	1083	1084	1085	1086	1087	1088	1089	1090	1091	1092	1093	1094	1095	1096	1097	1098	1099	1100	1101	1102	1103	1104	1105	1106	1107	1108	1109	1110	1111	1112	1113	1114	1115	1116	1117	1118	1119	1120	1121	1122	1123	1124	1125	1126	1127	1128	1129	1130	1131	1132	1133	1134	1135	1136	1137	1138	1139	1140	1141	1142	1143	1144	1145	1146	1147	1148	1149	1150	1151	1152	1153	1154	1155	1156	1157	1158	1159	1160	1161	1162	1163	1164	1165	1166	1167	1168	1169	1170	1171	1172	1173	1174	1175	1176	1177	1178	1179	1180	1181	1182	1183	1184	1185	1186	1187	1188	1189	1190	1191	1192	1193	1194	1195	1196	1197	1198	1199	1200	1201	1202	1203	1204	1205	1206	1207	1208	1209	1210	1211	1212	1213	1214	1215	1216	1217	1218	1219	1220	1221	1222	1223	1224	1225	1226	1227	1228	1229	1230	1231	1232	1233	1234	1235	1236	1237	1238	1239	1240	1241	1242	1243	1244	1245	1246	1247	1248	1249	1250	1251	1252	1253	1254	1255	1256	1257	1258	1259	1260	1261	1262	1263	1264	1265	1266	1267	1268	1269	1270	1271	1272	1273	1274	1275	1276	1277	1278	1279	1280	1281	1282	1283	1284	1285	1286	1287	1288	1289	1290	1291	1292	1293	1294	1295	1296	1297	1298	1299	1300	1301	1302	1303	1304	1305	1306	1307	1308	1309	1310	1311	1312	1313	1314	1315	1316	1317	1318	1319	1320	1321	1322	1323	1324	1325	1326	1327	1328	1329	1330	1331	1332	1333	1334	1335	1336	1337	1338	1339	1340	1341	1342	1343	1344	1345	1346	1347	1348	1349	1350	1351	1352	1353	1354	1355	1356	1357	1358	1359	1360	1361	1362	1363	1364	1365	1366	1367	1368	1369	1370	1371	1372	1373	1374	1375	1376	1377	1378	1379	1380	1381	1382	1383	1384	1385	1386	1387	1388	1389	1390	1391	1392	1393	1394	1395	1396	1397	1398	1399	1400	1401	1402	1403	1404	1405	1406	1407	1408	1409	1410	1411	1412	1413	1414	1415	1416	1417	1418	1419	1420	1421	1422	1423	1424	1425	1426	1427	1428	1429	1430	1431	1432	1433	1434	1435	1436	1437	1438	1439	1440	1441	1442	1443	1444	1445	1446	1447	1448	1449	1450	1451	1452	1453	1454	1455	1456	1457	1458	1459	1460	1461	1462	1463	1464	1465	1466	1467	1468	1469	1470	1471	1472	1473	1474	1475	1476	1477	1478	1479	1480	1481	1482	1483	1484	1485	1486	1487	1488	1489	1490	1491	1492	1493	1494	1495	1496	1497	1498	1499	1500	1501	1502	1503	1504	1505	1506	1507	1508	1509	1510	1511	1512	1513	1514	1515	1516	1517	1518	1519	1520	1521	1522	1523	1524	1525	1526	1527	1528	1529	1530	1531	1532	1533	1534	1535	1536	1537	1538	1539	1540	1541	1542	1543	1544	1545	1546	1547	1548	1549	1550	1551	1552	1553	1554	1555	1556	1557	1558	1559	1560	1561	1562	1563	1564	1565	1566	1567	1568	1569	1570	1571	1572	1573	1574	1575	1576	1577	1578	1579	1580	1581	1582	1583	1584	1585	1586	1587	1588	1589	1590	1591	1592	1593	1594	1595	1596	1597	1598	1599	1600	1601	1602	1603	1604	1605	1606	1607	1608	1609	1610	1611	1612	1613	1614	1615	1616	1617	1618	1619	1620	1621	1622	1623	1624	1625	1626	1627	1628	1629	1630	1631	1632	1633	1634	1635	1636	1637	1638	1639	1640	1641	1642	1643	1644	1645	1646	1647	1648	1649	1650	1651	1652	1653	1654	1655	1656	1657	1658	1659	1660	1661	1662	1663	1664	1665	1666	1667	1668	1669	1670	1671	1672	1673	1674	1675	1676	1677	1678	1679	1680	1681	1682	1683	1684	1685	1686	1687	1688	1689	1690	1691	1692	1693	1694	1695	1696	1697	1698	1699	1700	1701	1702	1703	1704	1705	1706	1707	1708	1709	1710	1711	1712	1713	1714	1715	1716	1717	1718	1719	1720	1721	1722	1723	1724	1725	1726	1727	1728	1729	1730	1731	1732	1733	1734	1735	1736	1737	1738	1739	1740	1741	1742	1743	1744	1745	1746	1747	1748	1749	1750	1751	1752	1753	1754	1755	1756	1757	1758	1759	1760	1761	1762	1763	1764	1765	1766	1767	1768	1769	1770	1771	1772	1773	1774	1775	1776	1777	1778	1779	1780	1781	1782	1783	1784	1785	1786	1787	1788	1789	1790	1791	1792	1793	1794	1795	1796	1797	1798	1799	1800	1801	1802	1803	1804	1805	1806	1807	1808	1809	1810	1811	1812	1813	1814	1815	1816	1817	1818	1819	1820	1821	1822	1823	1824	1825	1826	1827	1828	1829	1830	1831	1832	1833	1834	1835	1836	1837	1838	1839	1840	1841	1842	1843	1844	1845	1846	1847	1848	1849	1850	1851	1852	1853	1854	1855	1856	1857	1858	1859	1860	1861	1862	1863	1864	1865	1866	1867	1868	1869	1870	1871	1872	1873	1874	1875	1876	1877	1878	1879	1880	1881	1882	1883	1884	1885	1886	1887	1888	1889	1890	1891	1892	1893	1894	1895	1896	1897	1898	1899	1900	1901	1902	1903	1904	1905	1906	1907	1908	1909	1910	1911	1912	1913	1914	1915	1916	1917	1918	1919	1920	1921	1922	1923	1924	1925	1926	1927	1928	1929	1930	1931	1932	1933	1934	1935	1936	1937	1938	1939	1940	1941	1942	1943	1944	1945	1946	1947	1948	1949	1950	1951	1952	1953	1954	1955	1956	1957	1958	1959	1960	1961	1962	1963	1964	1965	1966	1967	1968	1969	1970	1971	1972	1973	1974	1975	1976	1977	1978	1979	1980	1981	1982	1983	1984	1985	1986	1987	1988	1989	1990	1991	1992	1993	1994	1995	1996	1997	1998	1999	2000	2001	2002	2003	2004	2005	2006	2007	2008	2009	2010	2011	2012	2013	2014	2015	2016	2017	2018	2019	2020	2021	2022	2023	2024	2025	2026	2027	2028	2029	2030	2031	2032	2033	2034	2035	2036	2037	2038	2039	2040	2041	2042	2043	2044	2045	2046	2047	2048	2049	2050	2051	2052	2053	2054	2055	2056	2057	2058	2059	2060	2061	2062	2063	2064	2065	2066	2067	2068	2069	2070	2071	2072	2073	2074	2075	2076	2077	2078	2079	2080	2081	2082	2083	2084	2085	2086	2087	2088	2089	2090	2091	2092	2093	2094	2095	2096	2097	2098	2099	2100	2101	2102	2103	2104	2105	2106	2107	2108	2109	2110	2111	2112	2113	2114	2115	2116	2117	2118	2119	2120	2121	2122	2123	2124	2125	2126	2127	2128	2129	2130	2131	2132	2133	2134	2135	2136	2137	2138	2139	2140	2141	2142	2143	2144	2145	2146	2147	2148	2149	2150	2151	2152	2153	2154	2155	2156	2157	2158	2159	2160	2161	2162	2163	2164	2165	2166	2167	2168	2169

Introducing the PT-88 jet printer.



Anything else is just a lot of noise.

In a market where noisy superlatives such as "incomparable", "second-to-none", and "the epitome of excellence" are casually applied to a wide variety of printers, Siemens has taken a more quiet and purposeful approach.

The PT-88 is our new jet matrix printer. Upon close inspection, you'll see that it is equipped with all the features your business can benefit from—consistent print quality in a variety of type styles, high speed (150 cps), tractor or single-sheet plain paper feed, full graphics capability, universal interface with personal or desk computers, and modular design for simplified service, if it is ever required.

But in addition to this, the PT-88 offers you something that many others simply can't... a QUIET working environment. Listen very carefully. The super-silent PT-88 whispers while it works, at less than 50 dBA. Compare it to those that operate at more than twice that sound level and clang, screech, rattle and shriek. Then think of how nice it will be to accept phone calls or conduct meetings while the PT-88 is hard at work...right next to your work place if you wish.

In short, the PT-88 puts it all together—reliability, flexibility, performance, and low-cost operation—all in one compact, super-silent unit. The result is a printer of exceptional long-term value. Now the question remains—Is it incomparable? Second-to-none? The epitome of excellence? We'd want you to decide for yourself. One thing's for sure. It's remarkably quiet. And in an increasingly noisier business environment, we think that's something you can appreciate.

For more information, contact:
Siemens Communication Systems, Inc.
Office Terminals Division
186 Wood Avenue South
Iselin, NJ 08830
(201) 321-3400 or
240 East Palais Road, Anaheim, CA 92805
(714) 991-9700.

Quietly impressive printers... from Siemens.

A Tour Through the Unix File System

*How to find your way around in the multiuser
Unix operating system and its associated files*

by James Joyce

Unix, a large operating system designed for multiple users, gives rise to many system and user files that can be segregated into different file areas, each with its own directory. This is preferable to having hundreds of files lumped into one work area because a simple request for a directory listing would fill a terminal's screen several times over. The Unix operating system, therefore, has a hierarchical, or tree-like, file system (though the tree is upside down, with the root at the top), allowing directories to contain subdirectories. Some users find themselves at a loss to understand the tangle this seems to present. Let's take a tour of the file system and pause at points of interest to see the sights.

The first point of interest is where we get on the tour by logging into a Unix system. I'll use my company's system in these examples:

```
ITS UNIX Welcomes You. Please,
```

```
:login: guest
```

```
Password:
```

```
Step right this way for the tour!
```

```
%
```

The login procedure is standard on multiuser systems, with the system identifying itself and asking for user's name and password, then giving the message of the day once you successfully log on. The % is the Unix command interpreter's prompt character, letting you know it awaits your next command. Unix users will recognize the prompt as that of the C-shell developed by Bill Joy at the University of California at Berkeley. I will present examples in terms of the C-shell because it and other Berkeley enhancements to Unix are in widespread use

throughout the Unix community and because all examples will be typescripts of an actual tour through the file system on my company's computer. Everything I type in and the system's responses have been captured by the script program developed by Mark Horton while he was also at Berkeley.

To tell where we are in the file system, the `pwd` command will print the working directory; that is, the directory where we are currently working within the Unix file system. In Unix, a *directory* is a file containing information about other files that are said to be "inside" it.

```
% pwd  
/usr/guest  
%
```

The result of `pwd` is the full *path name* to the working directory, showing which directories you go through to get to the present directory. The first slash (/) indicates root, the top of the file system hierarchy. The root file contains `usr` (pronounced "user"—the directory of users), and the second slash separates the name `usr` from `guest`, our account name. The `guest` directory is inside the `usr` directory and contains all the files of the guest account. Figure 1 is a diagram of this relationship. Directory entries include *pointers* to files elsewhere on the disk, as the lines in the diagram suggest, rather than the actual files themselves.

What's Inside `/usr/guest` ?

The login directory `/usr/guest` contains several files whose names you can see by typing the `ls` command to list file names:

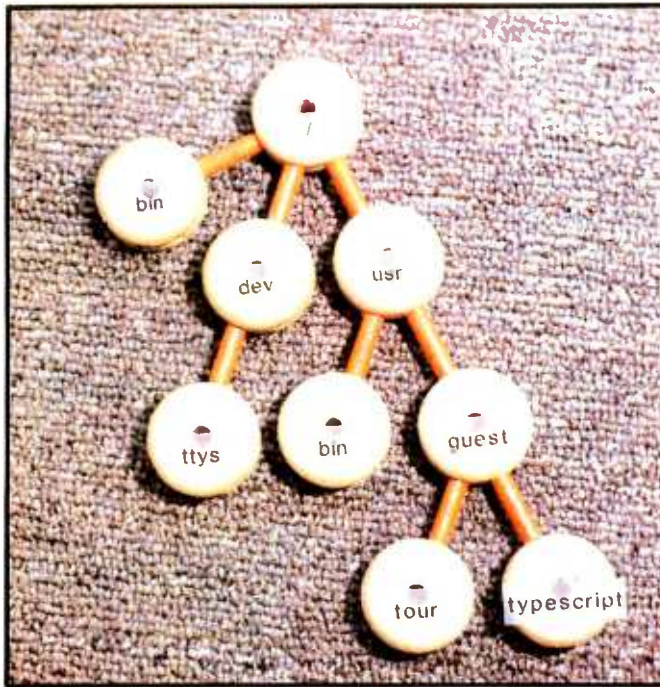

Figure 1: The relationship of directories and files in the Unix hierarchical file system. (Photo by James Joyce.)

```
% ls
tour
typescript
%
```

The file `tour` contains the text of this article, and `typescript` is the copy of what appears on my screen during the tour presented here.

The command `ls -a` produces a list of *all* files, even those that begin with a period or "dot" (`.`), which usually indicates special system file names.

```
% ls -a
.
..
.cshrc
tour
typescript
%
```

We see three new files, the names of which are pronounced "dot," "dot-dot," and "dot-c-s-h-r-c." The first filename, "dot," is a nickname for the current directory. (Perhaps an easy way to remember this is to think of the dot as the Unix shell, or command interpreter, pressing its finger against the inside of the screen to point to where it's currently working.) The listing of files gives the `.` and `..` directories, too, which means directories also are files. The second file, "dot-dot," is short for the parent directory, one level up from where you are. Every directory has at least two entries in it, one for "dot" and one for "dot-dot," files that are automatically created whenever a directory is made using `mkdir`, the make-directory command.

The file `.cshrc` is used by the C-shell to tailor its actions to your desires. You can even customize the prompt to something else by typing

```
set prompt="Yes, Jim?"
```

so that instead of `%` you are prompted with

```
Yes, Jim?
```

There is much more that can be done with the `.cshrc` file, but we must press on with the tour.

Permissions, Owners, Sizes of Files

So far we are learning how to be tourists in the Unix file system. The `pwd` command tells us what directory we are in, and the `ls` command tells us what files are in that directory. Next we'll learn about permissions, ownership, the size of files, and date stamping. The command `ls -la` produces the *long* listing of *all* files:

```
% ls -la
drwxr-xr-x  2 guest   144 Jun 25 12:49 .
drwxr-xr-x 32 root    544 Jun 21 00:26 ..
-rwx----- 1 guest    98 Dec 18 1982 .cshrc
-rw-rw-rw- 1 guest  1561 Jun 25 12:46 tour
----- 1 guest    176 Jun 25 12:50 typescript
%
```

The first character in each line is either a hyphen, indicating the file is an ordinary file, or a `d`, indicating the file is a directory. Not surprisingly, "dot" (our working directory) and "dot-dot" (our parent directory) have a

d in the first position of the long listing of files.

We can see the file names in the right-most column of the `ls` command's output. Reading from the right, we can see a date stamp, expressed as month and day (Jun 25 for `typescript`), and time of last modification (12:50 on a 24-hour clock). The 176 indicates the number of bytes in the file, and `guest` is the file's owner. The 1 indicates the number of links to the file. Because each file is minimally linked once to its parent directory, the number of links is at least one. If the link count drops to zero, the file is deleted.

The line of hyphens for `typescript` tells us that all *permissions* for the file are "turned off." However, the line of permissions for `tour` says read and write permissions (`r` and `w`) are enabled for (from left to right) owner, group, and everyone else. This file is actually writable by anyone on the system—usually not a good idea, but a demonstration here of permissions.

Permissions for `.cshrc` are turned off for the group and everyone else, but the owner can read, write, and execute (`r`, `w`, and `x`) the file. Note that although "dot" is owned by `guest`, "dot-dot" is not—it is owned by `root`, the parent of all Unix files.

Changing Directories

The `cd` command changes directories, and if you simply want to go up one level the command is

```
% cd ..
%
```

and, to verify that you have done so:

```
% pwd
/usr
%
```

Instead of `/usr/guest` the response from `pwd` is `/usr`, meaning that you have successfully moved up one level in the file system. The next thing to do is to see what files are at that level:

```
% ls -l
drwxr-xr-x 2 root      64 Jun 11 12:27 adm
drwxr-xr-x 2 check    400 Jun 22 14:22 bin
drwxr-xr-x 2 root     128 Jun 11 12:33 dict
drwxr-xr-x 3 root     336 Jun 11 12:38 games
drwxr-xr-x 2 guest    144 Jun 25 12:49 guest
drwxr-xr-x 4 root     448 Jun 11 12:46 include
drwxr-xr-x 9 jim      528 Jun 24 17:26 jim
drwxr-xr-x 13 root    496 Jun 13 15:41 lib
drwxr-xr-x 20 root    320 Jun 11 13:16 man
drwxr-xr-x 2 root     32 Jun 11 13:17 preserve
drwxr-xr-x 7 root     112 Jun 11 13:19 spool
drwxr-xr-x 14 root    320 May 30 15:06 src
drwxr-xr-x 2 root    112 Jun 11 13:20 sys
%
```

In this and following long listings of directories, some

lines have been omitted to save space.

We see `guest` in the list, the directory we just left. It comes alphabetically in the list, just after `games`, the directory where the Unix games are. The `man` directory contains the online *Unix Programmer's Manual*, and `src` and `sys` contain, respectively, the source code for the user utilities and for the Unix system.

A Visit to Root

The root directory, `/`, is the parent of all directories, the *primum mobile* of the Unix system. And when we move up one level, and look at the contents of root we see:

```
% cd /
% pwd
/
% ls -l
drwxr-xr-x 2 root      2672 Apr  5 16:38 bin
drwxr-xr-x 2 root      1024 Jun  8 15:21 dev
drwxr-xr-x 2 root       480 Jun 11 23:01 etc
drwxr-xr-x 2 root       448 Jun  8 17:00 lib
drwxr-xr-x 2 root     4128 Oct  5 1982 lost+found
drwxrwxrwx 2 root        32 Oct  5 1982 mnt
drwxrwxrwx 5 root       464 Jun 25 12:48 tmp
-rwxr--r-- 1 root    65206 Jun  8 12:09 unix
drwxr-xr-x 32 root      544 Jun 21 00:26 usr
%
```

The directory `bin` (pronounced as it is spelled) contains the executable binary versions of the Unix utilities, such as `ls` and `pwd`. Scanning down the list, the eye leaps to the file named `unix`. Unlike the other files, it is not a directory. It is an executable file, as the permissions indicate, but it is executable only by `root`, the owner. The file `unix` is the *kernel*, or the control program, of the Unix system. `Unix` is a term that can apply either to the kernel of the Unix system or to the totality and functionality of programs that run on the Unix system.

Let's tour some of the more interesting directories.

Touring /bin

First we will change our working directory into `/bin` and then find the number of files inside it.

```
% cd /bin
% ls | wc -l
165
%
```

The second line in the example is a two-part command. First `ls` is run, and its output is sent (or *piped*) to the `wc` (word count) program, which is in turn told to report only the number of lines it counts. There are 165 commands in `/bin`. To see them we type

```
% ls -l
-rwx--x--x 1 bin      34964 Oct  5 1982  adb
-rwx--x--x 1 bin       307 Oct  5 1982  calendar
-rwx--x--x 1 bin     9216 Oct  5 1982  cat
```



The 3 reasons why our software should cost you an arm and a leg...

1. We are highly specialized and limit our production to only 7 categories: MANUFACTURER, WHOLESALER, DOCTORS, DENTISTS, CHURCHES, SCHOOLS AND FINANCIAL PACKAGES.
2. Our distribution and service network blankets the nation and spans the globe.
3. Our microcomputer software is so finely tuned and incredibly simple it will make your secretary into a computer wizard.

These are the reasons why our software should cost you a lot, and they are precisely the reasons why it won't. . .

1. Specialization increases quality but reduces research and development costs.
2. Worldwide distribution increases volume and reduces unit costs.
3. Simplicity increases effectiveness but reduces installation and operation costs.

For complete information about the microcomputer software that should cost you an arm and a leg, but doesn't, just send for our free brochure. It deals exclusively with your business or profession and it is written in very plain English. The brochure is free, and the postage is paid.

**DISTRIBUTOR AND DEALER
INQUIRIES ARE WELCOME.**



ims
**INTERNATIONAL
MICRO SYSTEMS**

6445 Metcalf • Shawnee Mission, KS 66202
(913) 677-1137

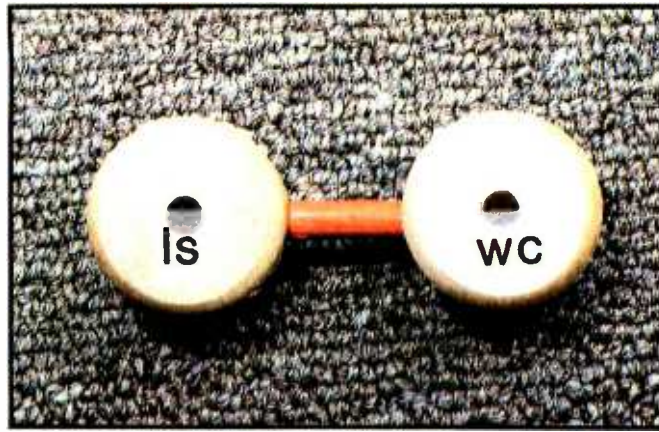

Figure 2: An example of piping the output of one program through another program. (Photo by James Joyce.)

```

-rwx--x--x 1 bin      12060 Oct 5 1982  cb
-rwx--x--x 1 bin      12892 Oct 5 1982  cc
-rwx--x--x 1 bin       8288 Oct 5 1982  chmod
-rwx--x--x 1 bin       9528 Oct 5 1982  cp
-rwx--x--x 1 bin     61212 Oct 5 1982  csh
-rwx--x--x 1 bin     10836 Oct 5 1982  date
-rwx--x--x 1 bin       2748 Oct 5 1982  echo
-rwx--x--x 1 bin     40244 Oct 5 1982  eqn
-rwx--x--x 1 bin     12508 Oct 5 1982  file
-rwx--x--x 1 bin     14324 Oct 5 1982  find
-rwxr-xr-x 1 bin        438 Oct 5 1982  lint
-rwx--x--x 1 bin     20564 Oct 5 1982  login
-rwx--x--x 1 bin     21148 Oct 5 1982  ls
-rws--x--x 1 root     23972 Oct 5 1982  mail
-rwx--x--x 1 bin     12112 Oct 5 1982  man
-rws--x--x 1 root      8636 Oct 5 1982  mkdir
-rwx--x--x 1 root     10236 Oct 5 1982  mv
-rwx--x--x 1 bin     57844 Oct 5 1982  nroff
-rws--x--x 1 root     16808 Oct 5 1982  passwd
-rwx--x--x 1 bin      8436 Oct 5 1982  pwd
-rwx--x--x 1 bin     10140 Oct 5 1982  rm
-rwx--x--x 1 bin     12564 Oct 5 1982  script
-rwx--x--x 1 bin     24900 Oct 5 1982  sh
-rwxr-xr-x 1 bin       546 Oct 5 1982  spell
-rwx--x--x 1 bin     42964 Oct 5 1982  tbl
-rwx--x--x 1 bin     62496 Oct 5 1982  troff
-rwx--x--t 4 bin     120456 Oct 5 1982  vi
-rwx--x--x 1 bin      8536 Oct 5 1982  wc
%
```

Some of the files, such as *vi*, the visual screen editor, seem astonishingly large, and others, such as *spell*, the program that checks spelling, seem astonishingly small. One explanation is that small files may be *shell scripts*, or files containing lines of shell commands that call on other programs to do parts of the desired task under the direction of the script.

Two entries in the long listing deserve brief mention. The *vi* entry has a *t* where execute permission for others is normally indicated. The *t* signifies that the "sticky bit" is set, so that *vi* stays around in the system's swap space, ready for execution. The *s* in the entry for *mkdir* indicates

"set user identification code on execution," allowing the user access to otherwise restricted files.

The vast number of commands in *bin* and the pipe symbol (*|*) help applications developers join them like Tinkertoys to make new applications. A Tinkertoy-style example of piping the output of *ls* through *wc* can be seen in figure 2. Often, using shell scripts, developers can produce applications by using existing general-purpose programs. These applications may be slower than specific programs written from scratch, but developers will have something working quite a bit sooner.

Why /usr/bin ?

The */bin* directory is quite large, and in part to keep it manageable (remember that command names are searched for sequentially), the overflow from */bin* is put in */usr/bin*. The */usr/bin* directory is also the place for local program additions, although some installations create a directory called */local* for that purpose. Let's see what is in */usr/bin*.

```

% cd /usr/bin
% ls | wc -l
  22
% ls -l
-rwxr-xr-x 1 root      17020 Oct 27 1982  cu
-rwxr-xr-x 1 root     15652 Oct 27 1982  put
-rwxr-xr-x 1 root     21764 Oct 27 1982  take
-rwxr-xr-x 1 root     31060 Oct  5 1982  uucp
-rwxr-xr-x 1 root     18204 Oct  5 1982  uulog
-rwxr-xr-x 1 root      8712 Oct  5 1982  uuname
-rwxr-xr-x 1 root     28708 Oct  5 1982  uux
%
```

The first three files are parts of the *cu*, or call Unix, program that allows a user of one Unix system to call up another computer system over a telephone line and either execute commands on that system as though logged in as a normal user or communicate between the two machines to put a file to that system or take a copy

PKASO™

Printer Interface Family

and Apple //e...
We work together



PKASO Interfaces come complete with Cable, Instructional Diskette and Comprehensive Manual.

The PKASO family makes you and your Apple Computer a master of text and graphics.

PKASO makes it easy to use the features of your printer—select character sizes, vary line spacing, even print in colors. Simple PKASO commands make these features usable from the keyboard or a program.

PKASO also adds features to your system. Press a few keys and get a snapshot "dump" of the image you see on the screen—text or graphics. Add new characters and symbols that you couldn't print before, using our SuperFont™ system. Add our new PipeLine™ printing buffer and your printer can take its time while you and your Apple move on to the next task. The PipeLine is a modular add-on to the standard PKASO board.

The PKASO interface is designed for Apple II and Apple III in all the popular configurations. It prints in full color on the IDS Prism Printer, and in striking black on C. Itoh, Centronics, Epson, IDS, NEC, and Okidata matrix printers.

IS PipeLine™ PRINTING BUFFER

For Apple, IBM, TRS-80 and most leading personal computers.

NOW with **serial** as well as **parallel** output and

Random Access Processing
(pat. pending)



Interactive Structures Inc.
146 Montgomery Avenue
Bala Cynwyd, PA 19004
Telephone: (215) 667-1713

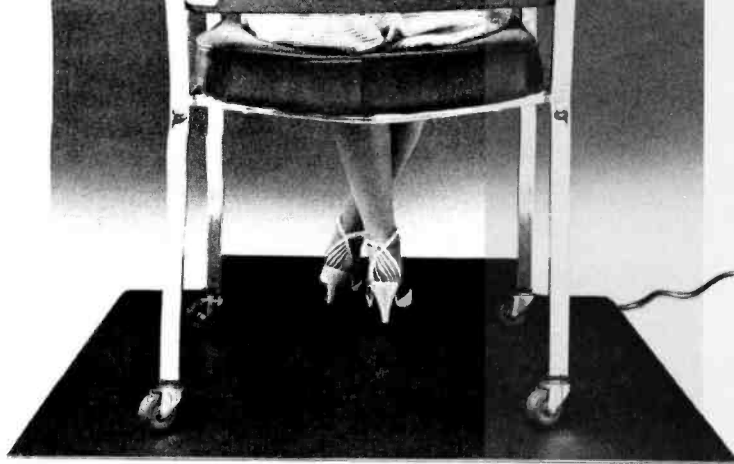

YOU CAN'T FIGHT STATIC SITTING DOWN.

Static electricity exists everywhere in an office environment—it's not just confined to a few square feet around a CRT. And when you consider that someone casually walking past a terminal can generate enough charges to trigger a major malfunction, it's clear that a small anti-static mat is hopelessly ineffective in protecting sensitive computers.

The solution is Staticide®. Unlike bulky mats, which can be unwelcome in a smartly-decorated office setting, Staticide provides an invisible barrier against static—a shield that remains in effect for up to six months with a single application. And while mats can cost hundreds, a quart of Staticide is only a few dollars. What's more, now you could wipe out static and dust attraction on CRT screens and keyboards with new Staticide® Wipes™.

Staticide from ACL. When you compare it against anti-static mats, the results will floor you.

Staticide
by ACL Incorporated

 1960 East Devon Ave.
Elk Grove Village, IL 60007
(312) 981-9212, TELEX: 4330251

Circle 12 on inquiry card.



We offer no static
to our customers.

of a file from that system. The other files are parts of the Unix-to-Unix copy program, an improved facility similar to cu. These communications capabilities come with the standard Unix system.

Relative Pathnames and /usr/lib

Because every directory's parent has the nickname "dot-dot," we can change into a directory at the same level (that is, attached to the same parent directory) as our present directory by using .. in the cd command.

```
% cd ../lib
%
```

We are now in /usr/lib and can see how many files there are and what they are by using the commands we've learned.

```
% ls | wc -l
29
% ls -l
-rw-r--r-- 1 root      57 Mar 17 23:27 crontab
drwxr-xr-x 2 root      432 Jun 11 12:53 font
drwxr-xr-x 2 root      64 Jun 11 12:49 lex
drwxr-xr-x 2 root      64 Jun 11 12:49 macros
-rwx--x--x 1 root     14876 Oct 27 1982 spell
drwxr-xr-x 2 root      192 Jun 11 12:51 tmac
drwxr-xr-x 3 root      496 Jun 11 12:52 uucp
%
```

The files are restricted in that they are readable by others or executable by others but not writable by others. Just as with library books from your local public library, you are not to write in the holdings in this electronic library.

Some of the directories here are specific libraries for the named programs. For example, lex is a library for the lex program in /bin, and uucp is a library for the uucp programs in /usr/bin. But what is the directory called font? We can go look with the command

```
% cd font
%
```

Typing the commands to tell us how many files are in a directory and what they are is becoming a bit tiresome, and so it is time to introduce the history mechanism of the C-shell.

Historical Commands

To see the most recent commands we have given the C-shell, we enter

```
% history
21 ls | wc -l
22 ls -l
23 cd font
24 history
%
```

May we interrupt the hoopla with a few facts?

Nothing in the noisy world of multi-user micros fits the requirements of business system integrators like our new desktop system — the MuSYS NET/work 8816™.

The MuSYS NET/work gives you multiprocessor architecture, extensive mass storage facilities (much greater than 8MB) and TurboDOS™, the high speed CP/M® compatible operating system. Gone are the bottlenecks that make shared-processor multi-user systems too sluggish for real world business applications. You'll also appreciate the 128K RAM per user,

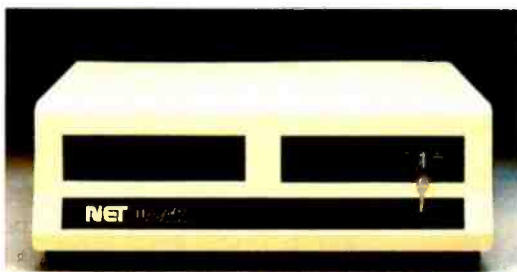

the local area networking capability (including Ethernet™), log-on security and other mainframe-like features that make the NET/work a truly professional, reliable business solution. Dealer and OEM customization programs available.

Get all the down-to-business facts! Call or write, MuSYS Corporation, 1752 Langley, Irvine, California 92714. (714) 662-7387 (toll-free outside California 1-800-852-5362). TWX: 910-595-1967. Cable: MUSYSIRIN.



We design the future.

The facts:	MuSYS NET/work 8816 ¹	ALLOS 8000-10	Televideo 806/20	Micromation Mariner
No. users (min/max)	2/8	4/4	1/6	1/8
Winchester formatted Mbytes (min/max)	16/102	10/20	15/30	20/40
Total RAM per user	128K	48K	64K	64K
User TPA	63.5K	48K	54K	62K
8- and/or 16-bit user processors	YES	NO	YES	NO
Perfect Software¹	YES	NO	NO	NO
Telecommunications Software	YES	NO	NO	NO
Operating system¹	Turbo-DOS	MP/MII	Mmm-OST	M/NET
Use with any terminal	YES	YES	NO	YES
Price (2 user system)	\$7,495 ²	\$7,490	\$10,785 ³	\$13,400

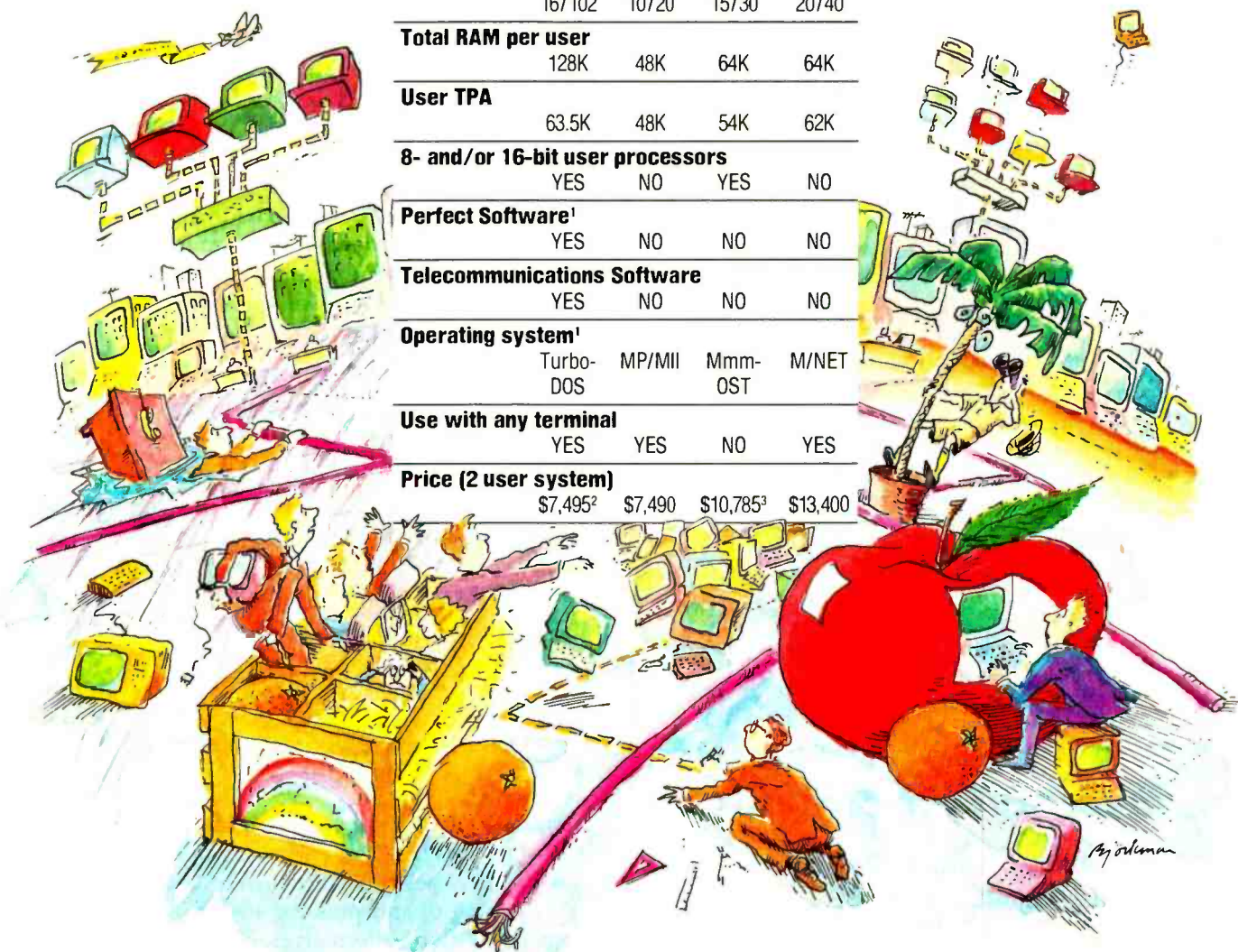

¹ NET/work 8816 is a trademarked product of MuSYS Corporation. Perfect Software is a trademarked product of Perfect Software, Inc. TurboDOS is a trademarked product of Software 2000, Inc. CP/M® and MP/MII are trademarked products of Digital Research, Inc. Mmmost is a trademarked product of Televideo. M/Net is a trademarked product of Micromation. Ethernet is a trademark of Xerox Corp. ² 8-User network is \$11,995. MuSYS prices include 16 MB formatted Winchester. ³ Includes terminals.

Super5

The Finest Quality Products for Apple® and IBM

The *Super5* stands alone in fine quality and workmanship.



Super5-CP80

- 640 dots/line. High density, high quality character.
- Bit image graphic.
- 40, 71, 80, 142 columns.
- Adjustable sprocket pin. feed plus friction feed.
- Cartridge ribbon.
- Standard centronics parallel. Optional RS232C.

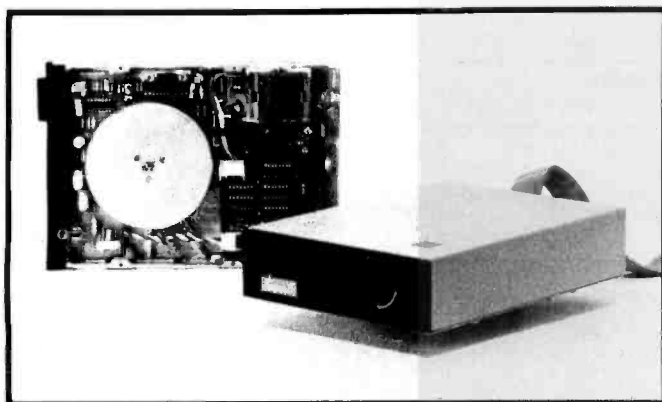

Super 5 has the following advantages compared to the normal floppy disk drive:

Characteristics	Super 5 - T 40	Normal Type
Servo motor/Spindle connection	Direct shaft drive	Belt drive
Head positioning mechanism	Metal band positioner	Plastic CAM positioner
Track to track time	Approx. 3.6 msec.	Approx. 40 msec.
Write-protected sensor	Photo coupler	Mechanical switch
No. of tracks	40 tracks	35 tracks

SUPER5-T40 single sided, direct shaft drive
 SUPER5-T80 double sided, direct shaft drive
 T40 drive control card: suitable for 35, 40 tracks drive
 T80 drive control card: suitable for 35, 40, 80 tracks drive

Mitsuba Corporation

667 Brea Canyon Rd., #25
 Walnut, CA 91789
 Tel.: (714) 594-6959

Japan: EI-EN Ent. TLX J23325
 Taiwan: GIFU Ent. TEL (02) 752-9661
 Hong Kong: A&N Ent. TEL 5-488463

The lines numbered 21 through 24 show the last four commands, indicating that they are the 21st through 24th commands typed so far. To execute a previous command, type the exclamation point (!) followed by the command number.

```
% !21
ls | wc -l
    25
%
```

Command number 21 is shown on the screen so you can see just what is being executed. After the command finishes, the output, 25, appears to let us know there are 25 files in the directory /usr/lib/font. Here are a few of them:

```
% !22
ls -l
-rw-r--r-- 1 root      256 Oct 27 1982  ftB
-rw-r--r-- 1 root      256 Oct 27 1982  ftI
-rw-r--r-- 1 root      256 Oct 27 1982  ftR
%
```

Again, a number of lines have been deleted in the interest of brevity. Those who know troff (the Unix typesetting utility) codes for the phototypesetter will recognize these names as the principal fonts—boldface, italic, and roman, respectively.

You Can Go Home Again

This tour has taken us far and wide in the file system, and even the most ardent Unix fan must admit to having gotten lost one time or another. Of course, we can always find out where we are by using the pwd command.

```
% pwd
/usr/lib/font
%
```

But how do we get back home, to our login directory? (In Unix terminology, the log-in directory is the home directory.) The cd command has a most pleasant default—if you do not type a file name, it defaults to your home directory.

```
% cd
% pwd
/usr/guest
%
```

So no matter how much you explore Unix, no matter how lost you may feel, and no matter how deep in directories you may be, you can return to your home directory by typing cd and pressing Return.

Unix offers many alternatives, and in fact there is another way to go home—through use of the tilde (~) notation:

When you visit your dealer and compare the Princeton IBM-compatible HX-12 side-by-side with the IBM color monitor, your eyes will see the difference.

The HX-12 gives you higher resolution and finer dot pitch (.31mm) than the IBM 5153's medium resolution (.43mm) for a cleaner, sharper image.

Compare our full range of colors and our crisp whites without red bleed. You'll also see a difference in

our non-glare screen—a feature your eyes will really appreciate in a long work session.

The Princeton HX-12 comes with a cable that plugs directly into the IBM PC, ready to burst forth into 16 superb colors. All at a suggested retail price (\$699) that's a pleasure for sore eyes and overworked budgets.

Apple IIe users: call us to learn how you, too, can now enjoy the visible superiority of the Princeton HX-12.

Ask your local dealer for a demonstration and let your eyes decide. Or call us at 800-221-1490 for more information and the name of your local dealer.

If you're ready to move up to color, graduate to the Princeton HX-12. It's right at the head of the class.



Princeton
Graphic
Systems

1101 State Road, Princeton, New Jersey 08540
609-683-1860, TLX 6857009 PGS Prin.
800-221-1490 Circle 372 on inquiry card

DON'T COMPROMISE:

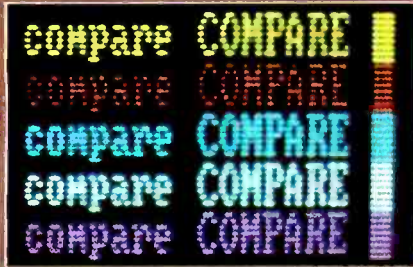

OURS: .31 mm dot pitch, 80 column text.



THEIRS: .43 mm dot pitch, 80 column text.

THE PRINCETON HX-12 HIGH RESOLUTION RGB COLOR MONITOR

for the Image
your eyes deserve



You'll never have a better reason
to begin shopping by mail:

RAM BOARDS

FOR THE IBM

256K

WITH AN RS-232C INTERFACE

\$349

\$507 WITH SUPERCALC 2

512K

WITH AN RS-232C INTERFACE

\$579

\$727 WITH SUPERCALC 2

Our fully-populated memory boards include parity checking and a standard RS-232C interface. They are compatible with all IBM software.

This is a rare opportunity to save a great deal of money without sacrificing quality. These boards meet the highest standards of design, materials and manufacturing available — at any price. They are completely guaranteed for two years.

Alpha Byte also carries the finest in IBM software, such as:

Lotus 1,2,3, D BASE II
Multiplan TK Solver
CP/M 86

Please call for our low prices or come visit us at our new California store.

Alpha Byte

COMPUTER
PRODUCTS

31304 VIA COLINAS
WESTLAKE VILLAGE, CA 91362

In Los Angeles:
(213) 706-0333

By Modem:
(213) 991-1604

CALL OUR MODEM LINE
FOR WEEKLY SPECIALS.

```
% cd ~guest
% pwd
/usr/guest
%
```

The tilde notation is not restricted to your home directory but can be used with any valid login name.

```
% cd ~jim
% pwd
/usr/jim
%
```

You can specify a directory within a login directory if you know its name.

```
% cd ~jim/letters
% pwd
/usr/jim/letters
%
```

The Unix System's Closet

We are nearing the close of our tour of the Unix file system, but we could not leave without looking into the Unix system's closet, */etc*.

```
% cd /etc
% ls | wc -l
28
% ls -l
-rwx----- 1 bin          7736 Apr  5 16:18 cron
-rw-r--r--  1 root         106 Jun  8 16:55 group
-rw-r--r--  1 bin           32 Jun  8 16:54 ident
-rwx----- 1 bin        6248 Apr  5 16:18 init
-rw-r--r--  1 bin           32 Jun 23 10:23 motd
-rw-r--r--  1 root        2467 Jun 21 00:26 passwd
-rw-r--r--  1 bin          321 Jun 21 15:43 rc
-rw-r--r--  1 bin       42020 Apr  5 16:18 termcap
-rw-r--r--  1 root         31 Jun 23 13:33 ttys
-rw-r--r--  1 bin          49 Jun 23 13:39 ttytype
%
```

Many people may already know that the online password file is */etc/passwd*. Some may have heard of *termcap*, the file that describes terminal capabilities to such programs as the *vi* screen editor, the *rogue* game (similar to *Dungeons and Dragons*), and application programs doing screen-oriented updating using the *curses* package. But few will have heard of the other files here. They are employed by the system rather than by users, although users definitely benefit from them.

The *ident* file contains the greeting that identifies the system to a potential user. The contents of this file can be displayed by typing *cat*, the Unix command commonly used to display a file.

```
% cat ident
ITS UNIX Welcomes You. Please,
%
```

We accept VISA, MasterCard or C.O.D. (add \$3 for C.O.D.). Add a \$3 shipping charge to prepaid orders; actual shipping charges will be added to non-prepaid. California residents, add appropriate sales tax.

Circle 27 on Inquiry card.

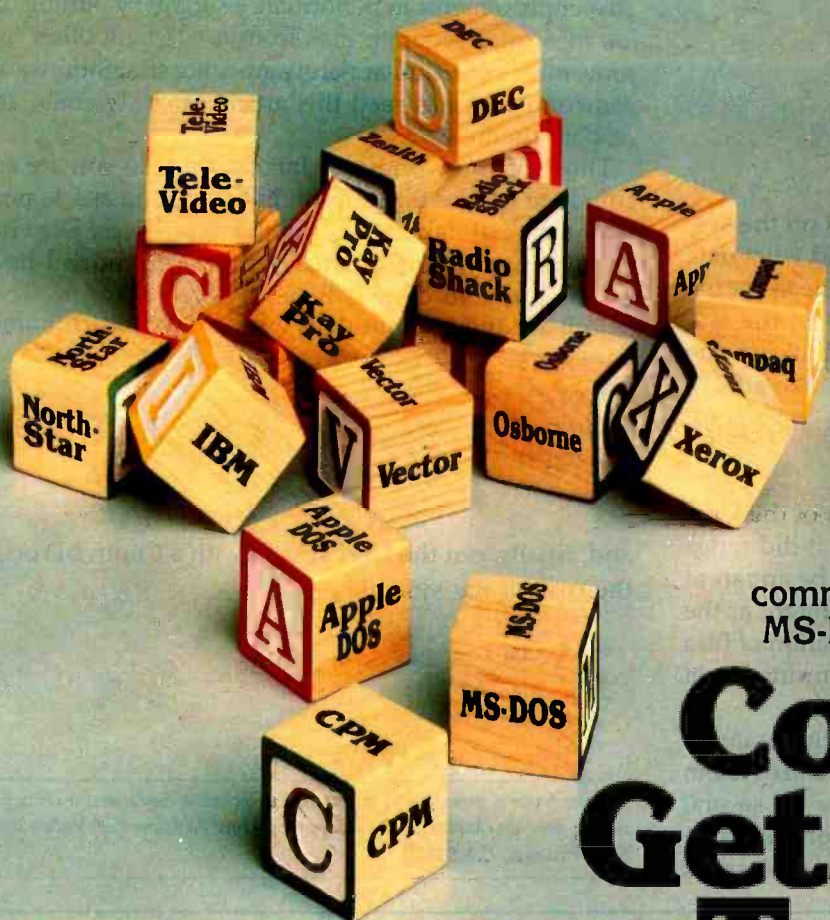

It's as simple as A B C...
 Converse offers you a very
 versatile, packed-with-features,
 communications package for CP/M,
 MS-DOS and Apple DOS systems.

Converse™ Gets Them Together

A	T	O	Z
Apple	Tele-Video	Osborne	Zenith
Radio Shack	North-Star	DEC	Vector
Kay Pro	IBM	Compaq	Xerox

Converse is a unique file transfer and telecommunications program for the non-technical as well as the professional user.

Converse features include:

- Compatible with auto-answer and auto-dial modems
- Terminal Mode operation with data capture option
- Error detection with automatic retransmission
- Remote operation mode
- Multiple file transfer with wild card option
- Status display
- Display of transmitted data stream in ASCII or HEX
- Completely menu driven for non-technical user
- Flexible software interface
- Multi-CPU licensing agreement

Ideal for multi-computer environments: dealers, software developers, clubs and schools. Whether you own Apple, IBM, Osborne or any other personal computer, Converse is the vital communications link that gets them together.

Disk and manual configured for Apple Dos, CP/M or MS-DOS \$145.00.

For any two of the above operating systems \$195.00. Order your Converse today.

Order Desk: (609) 854-5228 Technical Information: (609) 854-5234

PROFESSIONAL SOFTWARE PRODUCTS

Sentry Plaza Office Bldg. / 216 Haddon Ave. Suite 503 / Westmont, NJ 08108

Circle 376 on Inquiry card.



The motd file contains the message of the day, displayed as each user logs into the system.

```
% cat motd
```

```
Step right this way for the tour!
```

```
%
```

The ttys file tells whether a given terminal on the system is allowed to display a login message, and what data rate the terminal connected to it must be. The ttytype file tells the type of terminal that is connected to the system, so the routines that use termcap can look up the characteristics of a particular terminal and take advantage of its capabilities.

The End of This Tour

We now come to the end of this brief tour of the Unix file system. The tour did not last long, but it did range fairly widely over the file system. It should be apparent that the file system is highly organized, although, as the *Unix Programmer's Manual* indicates, the position of files is subject to change without notice. The warning is not given without reason.

Unix is disk-intensive, simply because there are so many files in so many directories. A typical Unix system takes 10 megabytes of disk storage to allow for several users. If the commands and user files are on the same disk, that disk often cannot keep up with the processor's

demands for data. Some Unix systems achieve noticeable improvements in performance simply by putting the /usr files on a separate disk from /bin. Many other improvements of a similar nature are quite straightforward; someone who has read this article carefully could anticipate them.

Those of you who have Unix available to you are encouraged to take this tour on line, with the article near your terminal, taking notes of the differences. Drawing a diagram of your system will show you much I have not had time to discuss here.

To leave the tour properly, we should return home:

```
% cd
% pwd
/usr/guest
%
```

and, finally, exit the Unix system with a Control-D or, in the case of my system,

```
% logout■
```

James Joyce is president of International Technical Seminars, a Unix consulting firm, and founder of the Independent Unix Bookstore (520 Waller Street, San Francisco, CA 94117).

We're Dealer Friendly

In this era of "user-friendly" computers and software, the needs of the dealer often are overlooked.

Not so with CMC.

We have been in the wholesale computer/peripheral business for over 4 years and fully understand the importance of responding quickly to dealers. CMC knows that in order for you to thrive, we must bust our fannies to make sure there is distributor support.

We make every effort to ship immediately from stock such noted products as:

COMPUTERS	SOFTWARE	HARD DISKS
CMC SuperSystems	Accounting Plus	Corvus
PMC MicroMate	Ashton Tate	CMC Targa™
Intertec	Champion	PRINTERS
	Chang Labs	Datasouth
	MicroPro	Panasonic
	Microstuff	Star Micronics
	Perfect Software	Teletex
	Sorcim	MISC.
	TERMINALS/ MONITORS	MicroBuffer
	Panasonic	Dattec Modems
	Teletex	Dysan Diskettes
		Smart Cable

CMC International
Distributed Products Division
Call 800-426-2963

(206) 885-1600 CMC INTERNATIONAL BUILDING 1720-130th Ave. N.E. BELLEVUE, WASH 98005

NEC's crisp, clear, high-performance JC1203 RGB color monitor, an industry standard. Also available, the JC1212 composite video version.

NEC's classic JB1201 green monitor, one of microcomputing's performance legends. Easy on the eye, and the checkbook.



Our impressive new NEC dot matrix printer. Parallel interface, 100 cps, 2K buffer, pin or friction feed. Stunning performance and compatibility in the hottest new peripheral of the year.

Give your IBM system some NEC, and watch its performance soar.

Peripherals from NEC can make almost any computer system better.

Our sparkling new JC1203 color monitor is plug and pin compatible with the 16-color IBM® PC, and delivers the bright, sharp, clear, and stable screen image for which the entire NEC line has long been famous. Similar compatibility is available to owners of Apple II®, Radio

Shack®, and Atari® computers, not to mention our own outstanding NEC PC-8000 series. Also available is a brand new, extremely low cost, NEC green monochrome monitor, the JB1260, perfect companion for an Osborne®, for instance.

Ask your dealer for a demonstration. Or write us at 1401 Estes Avenue, Elk Grove Village, IL 60007.

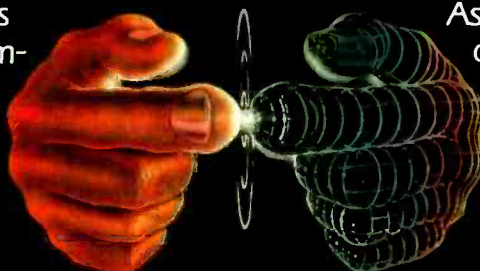

**Productivity
at your fingertips™**

NEC

**NEC Home Electronics (U.S.A.), Inc.
Personal Computer Division**

Nippon Electric Co., Ltd., Tokyo, Japan
Circle 383 on inquiry card.



Shown are IBM-PC compatible programs. The Columbia MPC runs MS-DOS® plus six other operating systems.



THE COLUMBIA MPC WORKS WITH A WORLD OF SOFTWARE. \$3,000 WORTH COMES FREE WITH THE SYSTEM.

World Headquarters:
9150 Rumsey Road
Columbia, MD 21045
(301) 992-3400
TWX 710-862-1891

West Coast:
3901 MacArthur Blvd.
Suite 211
Newport Beach, CA 92660
(714) 752-5215
Telex 277778

Europe:
Limitenstr. 94
4050 Moenchengladbach 2
West Germany
02166-17097
Telex 852452

**Call our distributor
nearest you.**

**Advanced Management
Systems**
Aurora, CO
(303) 752-2972
**Renaissance Technology
Corp.**
Concord, CA
(415) 676-5757

**Commercial Computer
Sales**
Atlanta, GA
(404) 256-9190
Miami, FL
(305) 266-9569
Maitland, FL
(305) 629-6114

RPC Electronics
Pittsburgh, PA
(412) 782-3770
Cleveland, OH
(216) 449-0550
Access Systems
Wellesley, MA
(617) 237-7743

Distributors in Australia, Austria, Belgium, Colombia, Denmark, Greece, Hong Kong, Israel, Italy, Kuwait, Malaysia, Netherlands-Antilles, Norway, Philippines, Portugal, Singapore, Spain, Sweden, Switzerland, Thailand, Turkey, United Kingdom, Venezuela.



Today, the Columbia MPC takes on hundreds of IBM-PC compatible software programs and IBM-PC add-ons or peripherals.

What's more, six other Columbia-supported operating systems are available — CP/M-80, CP/M-86, Concurrent CP/M-86, MP/M-86* (OASIS-16* and XENIX* available soon) — stretching the Columbia MPC's software compatibility beyond any other personal computer.

Farther, faster, for far less.

The Columbia MPC is shipped with fully supported software that will save you \$3,000. Included is the entire self-teaching Perfect Software™ family: Perfect Writer,™ a word processor; Perfect Speller,™ a 50,000 word dictionary; Perfect Filer,™ a data

base manager; and Perfect Calc,™ a financial calculation system.

In addition you get MS-DOS, CP/M-86, Macro/86 Assembler, BASICA,™ Asynchronous Communications Support, Diagnostics and the Columbia Tutor program. This means your Columbia MPC is up and running right out of the box. Space Commanders and Fast Graphs show off the Columbia MPC's full-color graphics.

Way out front in value and performance.

With a list price of \$3,995 — including 128K RAM, 640K in dual disk drives, 8 IBM-PC compatible expansion slots, 2 serial and 1 parallel I/O, IBM-PC compatible keyboard, and color graphics monitor controller — the Columbia MPC is

ready to go. And a complete 12MB hard disk system lists for \$5,995 — software included! B/W or color monitors and printers optional.

Made in U.S.A.—supported worldwide.

All Columbia hardware and software are backed by the "Call for Columbia" national service program. So, call us or our distributor for the dealer nearest you — and start looking at the Columbia MPC. It'll show you a whole new world of performance and value.

COLUMBIA
DATA PRODUCTS, INC.

- | | | | | | | |
|---|---|---|--|--|---|--|
| Compatible Data Systems, Inc.
Rochester, NY
(315) 437-3909
Philadelphia, PA
(215) 383-0180
N.Y. City, NY
(212) 259-1440 | Crystal Computers, Inc.
Lenexa, KS
(913) 541-1771
Florissant, MO
(314) 837-3003 | Hall-Mark Electronics
Dallas, TX
Call your local
Hall-Mark office or call:
(214) 343-5920 | MP Systems
Dallas, TX
(214) 385-8885 | Micro Distributing, Inc.
Coquitlam, B.C., Canada
(604) 941-0622 | Peripherals Plus, Inc.
Montreal, Quebec,
Canada
(514) 364-5554 | Zepher Industries, Inc.
Seattle, WA
(800) 562-5057
WA WATS
(800) 426-5047
Nationwide WATS |
| Southwest Data Products, Inc.
Houston, TX
(713) 461-0100 | Southeastern Data Products
Lynchburg, VA
(804) 384-6000 | Waybem Corporation
Garden Grove, CA
(714) 554-4520 | Wetaskiwin Computers
Wetaskiwin, Alberta,
Canada
(403) 352-9302 | Tele-Terminals
Brooklyn Park, MN
(612) 536-6000
Milwaukee, WI
(414) 785-9221 | Tek-Aids Industries
Arlington Heights, IL
(312) 870-7401 | |

Perfect Software, Perfect Writer, Perfect Speller, Perfect Filer, and Perfect Calc are trademarks of Perfect Software, Inc. Home Accountant Plus is a trademark of Continental Software Company. Fast Graphs is a trademark of Innovative Software, Inc. IBM and IBM-PC are trademarks of International Business Machines. CP/M and MP/M are registered trademarks of Digital Research, Inc. OASIS is a trademark of Phase One. MS-DOS, MS-BASIC and XENIX are trademarks of MICROSOFT. *Prices effective June 1, 1983

Circle 88 on inquiry card.

IN 1982, THE COMPETITION WAS BUSY TRYING TO COPY THE SemiDisk™

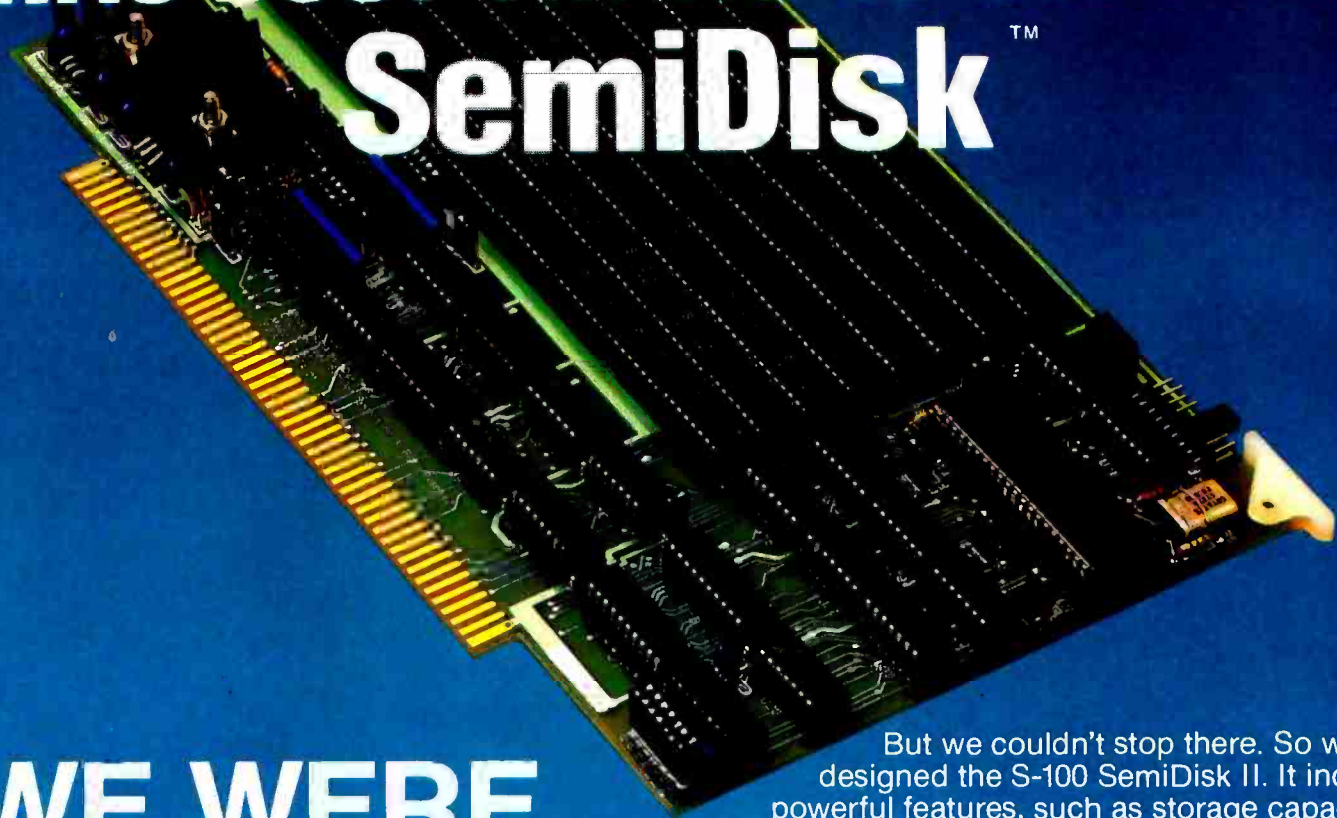

WE WERE BUSY, TOO

They say a moving target is harder to hit. Well, we've been moving very fast recently. Last year we introduced the **FIRST** and, until now, the best dedicated disk emulator ever designed for S-100 microcomputers, with unparalleled price and performance, the SemiDisk I. The original. Naturally, we had imitators. But nobody managed to duplicate SemiDisk's features, let alone improve on the idea. And now the original is even better: only \$1495 for 512 Kbytes, including the sophisticated SemiSpool print-spooler software system (only \$2350 for 1 Mbyte). Far better performance for much less money.

But we couldn't stop there. So we designed the S-100 SemiDisk II. It includes powerful features, such as storage capacity up to 2 Mbytes per board, 8 Mbyte total disk size, automatic power-fail check and battery backup provision, and on-board hardware parity checking for exceedingly fast operation. Features the competition can only wish they could offer. And at \$1795 for 512K (\$2650 for 1 Mbyte), it still costs less than inferior imitations.

Twice as fast as the SemiDisk I, SemiDisk II runs wide circles around hard disks, and blows floppies off the road. Needless to say, it leaves the competition crawling in the dust. So if you want the benefit of truly extraordinary computer performance, you'll find it in the SemiDisk II.

Make no mistake about it, SemiDisk II is the fastest, highest density, easiest to use, most compatible, most cost-effective microcomputer disk emulator ever built. And considering the SemiDisk I, that's really saying something.

SemiDisk

It's the disk the others are *still* trying to copy.

SemiDisk Systems, Inc.

P.O. Box GG Beaverton, OR 97075 (503) 642-3100

Call 503-646-5510 for CBBS™/NW, a SemiDisk-equipped computer bulletin board.

SemiDisk trademark of SemiDisk Systems, Inc. Copyright © 1983 SemiDisk Systems, Inc.



NO WAITING

The Unix Shell

The Unix shell is both an interactive command interpreter and a programming language

by Stephen R. Bourne

The Unix shell is both a programming language and a command language. As a command language it provides a user interface to the process- and file-handling facilities of the Unix operating system. As a programming language it contains mechanisms found in algorithmic languages. This combination encourages use of important concepts unique among operating systems. The shell can modify the environment in which commands are executed; the outcome of a command may determine the flow of control. The flow of data may also be controlled and redirected via the shell, enabling communication between processes.

The shell executes commands that are read from either a terminal or a file. Simple commands are written as sequences of "words" separated by blanks. The first word is the name of the command to be executed; remaining words are passed as arguments to the command invoked. For example, the command

```
ls -l
```

prints a list of the filenames in the current directory. The argument `-l` tells `ls` to print the date of last use, the size, and the status of each file.

Commands are similar to procedure calls in languages like Pascal or FORTRAN. The notation is different in two respects. First, although the arguments are arbitrary strings, they need not be enclosed in quotes in most cases. Second, there are neither parentheses enclosing the list of arguments nor commas separating

them. Command languages tend not to have the extensive expression syntax found in algorithmic languages. Their primary purpose is to issue commands; it is therefore important that the notation be free from superfluous characters.

To execute a command, the shell creates a new process and waits for it to finish. These operations are primitives available in the Unix operating system. A command may be run without waiting for it to finish using the postfix operator `&`. For example,

```
print file &
```

calls the `print` command with the argument `file` and executes it in the background. The `&` is a metacharacter (i.e., has special meaning to the shell) interpreted by the shell and is not passed as an argument to `print`.

Associated with each process is a set of file descriptors numbered 0, 1, . . . , used in all I/O (input/output) transactions between processes and the operating system. File descriptor 0 is termed the standard input, and file descriptor 1 is termed the standard output. Most commands produce their output on the standard output that is initially (after logging in) connected to a terminal. This output may be redirected for the duration of a command, as in

```
ls -l > file
```

The notation `>file` is interpreted by the shell and is not passed as an argument to `ls`. If the file does not

exist, it is created; otherwise, the contents of the file are replaced with the output from the command.

To append to a file, the notation `>>file` is provided, as in

```
ls -l >> file
```

The standard input may be taken from a file by writing, for example,

```
wc < file
```

`Wc` (word count) prints the number of characters, words, and lines on the standard input.

The standard output of one command may be connected to the standard input of another by writing the "pipe" operator, indicated by `|`, as in

```
ls -l | wc
```

Two commands connected in this way constitute a "pipeline," and the overall effect is the same as

```
ls -l > file
```

```
wc < file
```

except that no file is used. Instead, the two processes are connected by a pipe created by an operating system call. Pipes are unidirectional; synchronization is achieved by halting `wc` when there is nothing to read and halting `ls` when the pipe is full. The Unix operating system, not the shell, deals with this matter.

A *filter* is a command that reads input, transforms it in some way, and prints the result as output. One such filter, `grep` (to search a file for a pat-

1-2-3...

REASONS TO BUY FROM PACIFIC COMPUTERS...

low prices product support
satisfied customers

"When Data I/O decided to buy micro's we shopped around for the best prices. Imagine our surprise when we found Pacific Computers! Full service attention at mail order prices, a combination that made my job much easier. Informed, helpful and responsive."

Wes Gilbert
Director, Mgmt. Services

COMPUTERS

Franklin, Kaypro, Teletote Portable, Apple IIe, Altos, Zorba, Columbia Portable & Desktop PC's, Superbrain... more

CALL FOR LOWEST PRICE!

PRINTERS

Gemini 10x	\$329
Okidata 92	\$529
Diablo 620	\$952
Mannesmann Talley 160L 10" carriage w/tractor	\$659
Mannesmann Talley 180L 15" carriage w/tractor	\$861
Daisywriter	
17cps letter quality 48K	\$999
Microbuffer 64K stand alone	\$290
IDS Prism 132 Sprint, 3.4K Buffer	\$1179
Other Brands	We Have Them All!

MODEMS

Hayes 300 baud	\$209
Hayes 1200 baud	\$499
Hayes 1200B for IBM	\$459
Other Brands - We have 'em	CALL

MONITORS

BMC Green New Style	\$99
Amdek Amber	\$179
Taxan Amber	\$149
Taxan Green	\$143
Zenith ZVM 121 Green	\$95

APPLE PERIPHERALS

ALS CP/M	\$299
ALS Z Card	\$139
Apple Dumping	\$95
Grappler Plus	\$139
Grappler 16K Buffer Board	\$125
SSM Modemcard, internal, 300 baud	\$245
Shugart Drives	\$219
PFS Filler	\$89
PFS Report	\$69
More than 1000 programs	CALL
Other Products - We have 'em	CALL

IBM PERIPHERALS

AST I/O (no ram) w/1s. 1p.c.g.	\$219
AST Mega Plus 64K, 1s. c.	\$359
Tandon TM100-2 drive	\$259
Hercules Board w/monochrome & graphics	\$389
Peachtext 5000	\$275
Lotus 123	CALL
Multiplan	\$210
USI Color & Monochrome Graphics Card, new product	CALL
Davong, Corona, Tall Grass, Targa Hard Disks	CALL
PFS File	\$99
PFS Report	\$89
More! 100's of programs available	CALL

PACIFIC COMPUTERS

13256 Northup Way #7
Bellevue, WA 98005

to order call collect

206-641-7233

prices reflect 3% cash discount
Bank Cards FOB Seattle Sorry, no COD
All products currently in stock.

tern), selects from its input those lines that contain some specified string. For example,

```
ls | grep old
```

prints those filenames from the current directory that contain the string old.

A pipeline may consist of more than two commands; the input of each is connected to the output of its predecessor. For example,

```
ls | grep old | wc -l
```

prints the number of files in the current directory with names containing the string old.

Filename Generation

Many commands accept arguments that are filenames. For example,

```
ls -l main.c
```

prints information relating to the file main.c. The shell provides a mechanism for generating a list of filenames that match a pattern. For example,

```
ls -l *.c
```

generates, as arguments, to ls all filenames in the current directory that end in .c. The character * is a pattern that matches any string including the null string. In general, shell patterns are specified using the following notation: * matches any string of characters including the null string; ? matches any single character; [...] matches any of the individual characters enclosed. A pair of characters separated by a minus matches any character lexically between the pair.

For example,

```
[a-z]*
```

matches all names in the current directory beginning with one letter from a through z.

```
/usr/fred/epns/*
```

matches all names in the directory /usr/fred/epns that consist of at least one character. If no filename matches the

pattern, the pattern is passed, unchanged, as an argument. This mechanism is useful both to save typing and to select names according to some pattern. It may also be used for finding files. For example,

```
echo /usr/fred/*core
```

finds and prints the names of all core files in first-level directories of /usr/fred. (Echo is a standard command that prints its arguments, separated by spaces.) This feature can be expensive, requiring a scan of all subdirectories of /usr/fred.

There is one exception to the rules given for patterns. The character . (period) at the start of a filename must be explicitly matched.

```
echo *
```

therefore echoes all filenames that don't begin with . in the current directory.

```
echo .*
```

echoes all filenames that begin with . in the current directory. This prevents inadvertent matching of the names . ("current directory") and .. ("parent directory"). (Ls suppresses information for . and ..)

Care should be taken when you use the rm command with generated patterns. You could easily remove more files than you intend. To reduce the chance of error, first echo the pattern, as shown in this example:

```
echo tmp*
```

followed by

```
rm tmp*
```

Be careful not to introduce a space between tmp and *.

Interactive Use of the Shell

When the shell is used from a terminal, it issues a prompt before reading a command. By default this prompt is \$. It may be changed by setting the prompt string;

```
PS1=yesdear
```

up to
384k

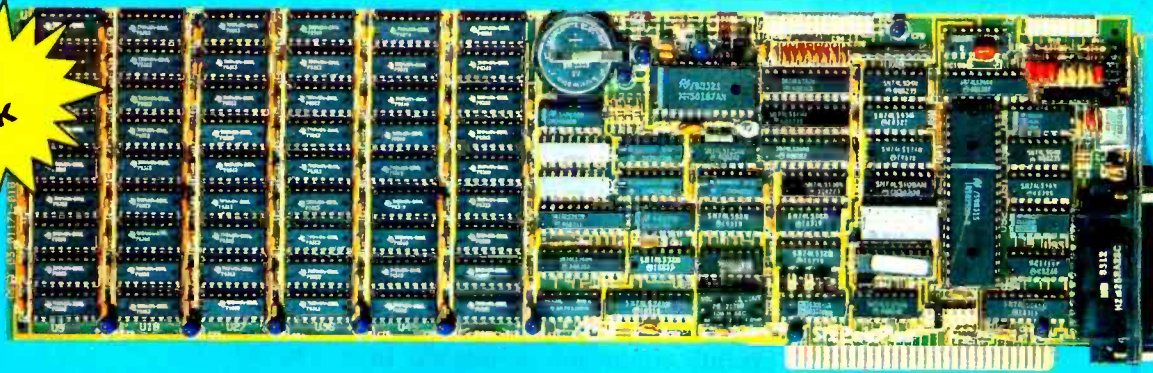

Thirsty for 384k for Your IBM PC? Try a SixPakPlus™

Since the introduction of DOS 2.0, the capabilities of the PC have been increased with the ability to address up to 640k of memory. With the current PC having 256k available on the computer motherboard, you need another 384k to reach 640k. Great you say, but multi-function boards only have room for 256k on them. Well look again, because now you can get the new SixPakPlus™ with up to 384k of memory, clock/calendar, asynchronous [RS232C serial] port, printer port, SuperDrive™ electronic disk emulation, and SuperSpooler™ printer spooling. There is even an optional game port. And if you already have enough memory for your present needs, you can still get on the bandwagon by buying it without any memory. When your needs for memory grow, the sockets are ready for you to install six banks of 64k parity checked memory.

With the SixPakPlus™ from AST Research you get the most advanced multifunction board available from the industry leader in IBM PC enhancements.

You get a clock/calendar powered by a clip-on battery which does not require factory service to replace. It automatically loads the correct time and date when you turn on your computer. The serial port can be configured as COM1 or COM2, and has jumpers for simplifying wiring of cables. The printer port uses all the same signals as IBM's — you can even use the IBM diagnostics on it. The optional game port uses any IBM compatible joystick.

The board is backed up with a one-year warranty on parts and labor and the Qubie™ satisfaction guarantee. If for any reason you are not satisfied with the performance of your board within 30 days of purchase, you may return it for a full refund, including the postage to return it. And if your board should need warranty service we do the repairs in 48 hours or we replace your board with a new one. That's the level of service that has made us the largest dealer in the world for AST Research products.

NOW
AVAILABLE
WITH
GAMEPAK



MegaPlus II & I/O-Plus II The Ultimate Expansion for IBM PC or XT

The AST Research MegaPlus II™ has three functions standard. Parity checked and fully socketed memory up to 256k in 64k increments, clock/ calendar with battery back-up for automatic loading of time and date when the computer is turned on; and asynchronous communication port [RS232C serial] which can be used as COM1 or COM2, (DTE for a printer, or DCE for a modem). Also included is SuperDrive™ "electronic disk" software. This program builds "disk drives" in memory which access your programs at the speed of RAM. You get SuperSpooler™, print spooling software. It operates your printer while you continue to work with your computer.

Options include a 100% IBM compatible parallel printer port (can be configured as LPT1, or LPT2), and a second RS232C asynchronous port (COM1 or COM2). Three MegaPak™ options can plug onto your MegaPlus II "piggyback" style to give you an additional 128k or 256k of memory, or a game port.

I/O-Plus II™, is the answer for those who don't need additional memory but would like all those other multi-function board features. The I/O-Plus II™ comes standard with a clip-on battery powered clock/calendar, an asynchronous communication port [RS232C serial], SuperDrive™ electronic disk, and SuperSpooler™ print spooling software.

Optional is a second asynchronous port (DTE, or DCE), a parallel printer adapter, and the best game paddle adapter on the market. It is an IBM standard game port, but it can also use Apple compatible paddles and joysticks. Options are all socketed so they may be added later should the need arise.

Both boards come with a one year factory warranty and the Qubie™ satisfaction guarantee. If for any reason you are not satisfied with the performance of your board within thirty days of purchase, you may return it for a full refund, including the postage to return it.

TO ORDER

BY MAIL INCLUDE:

- complete description of products requested
- daytime phone number
- California residents add 6% sales tax
- check or credit card number with expiration date (personal checks take 18 days to clear)



TO ORDER BY PHONE:

In California (805) 482-9829
Outside California TOLL FREE (800) 821-4479

PRICES:

I/O-Plus II™ with Clock/calendar, serial (asynchronous) port, SuperDrive™ and SuperSpool™
\$129

MegaPlus II™ no memory, with clock, serial, and software - \$229

SixPakPlus™ no memory, with clock, serial port, printer port, and software: \$229

Each 64k of memory installed and tested on MegaPlus, SixPakPlus or alone \$50
Parallel Printer Port \$35
Second Asynchronous Port \$35
Game Adapter (I/O or SixPakPlus) \$35
MegaPak™ with 256k of Memory \$299
128k of Memory \$199
GamePak for MegaPlusII \$40
ConnectAll Cable Bracket \$19
Cable to Parallel Printer \$35
Cable to Modem or Serial Printer \$25
Diagnostics Program \$10
SUPERWRITER by Sorcim \$179
SUPERCALC™ by Sorcim \$159
dBASE II by Ashton-Tate \$409
Word Processing Keyboard \$229
Keyboard/Superwriter Package \$399

SHIPMENT

Normal shipment is day after receipt of order. We pay UPS surface charges on all items except keyboards. For keyboard add \$5 for surface, \$10 for 2 day air. All COD shipments add \$3 handling.

QUANTITY PURCHASES?

If your corporation, institution, or users group has needs for quantities of boards, call us for details on our quantity purchase program.

QUBIE' DISTRIBUTING

4809 Calle Alto, Camarillo, CA 93010

Tempo House
15 Falcon Road, London, SW 11, UK

Circle 564 on Inquiry card.

sets the prompt to be the string `yesdear`. If a *newline* (carriage return) is typed and further input is needed, the shell issues the prompt `>`. Mis-typing a quotation mark sometimes causes this. If the prompt is unexpected, an interrupt returns the shell to read another command. This prompt may be changed by saying, for example,

PS2=more

Following login, the shell reads and executes commands typed at the terminal. If your home directory contains a file named `.profile`, the shell executes it before reading any commands from the terminal. The following `.profile` is typical:

```
date
calendar
MAIL=/usr/spool/mail/srb
HOME=/usr/srb
PATH=../bin:/usr/bin:$HOME/bin
TERM=...
```

export MAIL HOME PATH TERM

This profile also prints the date and checks the calendar reminder service. If you always use the same terminal, then you should set the TERM variable in the profile.

Shell Procedures

The shell may be used to read and execute commands contained in a file. For example,

```
sh file arg1 arg2 . . .
```

calls the shell (itself a program, called `sh`) to read commands from file. Such a file is called a "shell procedure." Arguments supplied with the call are referred to within the procedure using the positional parameters `$1,$2,. . .`. If the file `wg` contains

```
who | grep $1
```

```
then
```

```
sh wg fred
```

is equivalent to

```
who | grep fred
```

where `$1` is replaced by `fred`, and `sh` is an append command. (The command to end the case statement is `esac`, "case" spelled backward.) When `append` is called with one argument, as in

is equivalent to

```
sh wg fred
```

This enables shell procedures and programs to be used interchangeably.

Frequently, procedures are used to loop through the arguments (`$1, $2,. . .`), executing commands once for each argument. An example of such a procedure is `tel`, which searches the file `/usr/lib/telnet` containing lines of the form

```
fred 277-0123
bert 277-0789
```

GTEK INC. DEVELOPMENT HARDWARE/SOFTWARE
HIGH PERFORMANCE/ COST RATIO
EPROM PROGRAMMER (601) 467-8048

Compatible w/all Rs 232 serial interface port * Auto select baud rate * With or without handshaking * Bidirectional Xon/Xoff and CTS/DTR supported * Read pin compatible ROMS * No personality modules * Intel, Motorola, MCS86, Hex formats * Split facility for 16 bit data paths * Read, program, formatted list commands * Interrupt driven, program and verify real time while sending data * Program single byte, block, or whole EPROM * Intelligent diagnostics discern bad and erasable EPROM * Verify erasure and compare commands * Busy light * Complete w/Textool zero insertion force socket and integral 120 VAC power (240 VAC/50Hz available)

DR Utility Package allows communication with 7128, 7228, and 7956 programmers from the CP/M command line. Source Code is provided. PGX utility package allows the same thing, but will also allow you to specify a range of addresses to send to the programmer. Verify, set the Eprom type.

MODEL 7316 PAL PROGRAMMER
 Programs all series 20 PALS. Software included for compiling PAL source codes.

Software Available for CPM,¹ ISIS,² TRSDOS,³ MSDOS.⁴

1. TM of Digital Research Corp.
2. TM of Intel Corp.
3. TM of Tandy Corp.
4. TM of Microsoft.

Post Office Box 289
 Waveland, Mississippi 39576
 (601)-467-8048

Avocet Cross Assemblers are available to handle 8748, 8751, Z8, 6502, 680X, etc. Available for CP/M and MSDOS computers. Order by processor type and specify kind of computer.

Model DE-4 U/V Products hold 8, 28 pin parts. High quality professional construction.

\$799 stand alone
MODEL 7956



MODEL 7956 GANG PROGRAMMER

Intelligent algorithm. Stand alone, copies eight EPROMS at a time. With RS-232 option \$999.

\$499
MODEL 7316

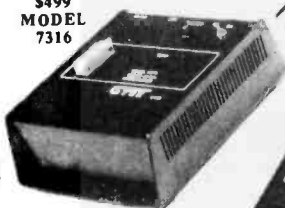

\$1195
MODEL 7324



MODEL 7324 PAL PROGRAMMER
 Programs all series 20 & 24 PALS. Operates stand alone or via RS232.

\$499
MODEL 7228



MODEL 7228 EPROM PROGRAMMER

All features of Model 7128 plus Auto Select Baud, super fast adaptive programming algorithms, low profile aluminum enclosure. Programs 2764 in one minute!

\$389
MODEL 7128



MODEL 7128 EPROM PROGRAMMER
 Programs and Read:

NMOS	NMOS	CMOS	EEPROM	MPU'S
2508	2758	27C16	5213	8748
2516	2716	27C32	5213H	8748H
2632	2732	C6716	X2816	8749H
2564	2732A	27C54	48016	8741
68766	2764		12816A	8742H
68764	27128			8741H
8755	27256			8751
5133				

- Model 7128-L1,L2,L2A . \$209.00
- Model 7128-24 \$289.00
- DR8 or DR5 \$ 30.00
- DR8PGX or DR5PGX . . . \$ 75.00
- Cross Assemblers \$200.00
- XASM (for MSDOS) . . . \$250.00
- U/V Eraser DE-4 \$ 78.00
- RS232 Cables \$ 30.00
- 8751 adapter \$174.00
- 8755 adapter \$135.00
- 48 Family adapter \$ 98.00

A coloring book for your computer.

This is no children's toy. This is no-nonsense quality, yet affordable. It's the Panasonic Digital Plotter — the high-speed peripheral that turns business computer graphics into high resolution full color hard copy.

Nothing can match the Panasonic Plotter in its price range. It provides six-color graphics at a fast 400mm (16") per second, with a choice of fiber, ball point or plastic tip pens in black, red, purple, blue, green and brown.

What's more, it's got a high level of built-in intelligence that greatly simplifies external programming. With simple commands, you create lines, circles and a full ASCII character set. Plus complex, color-

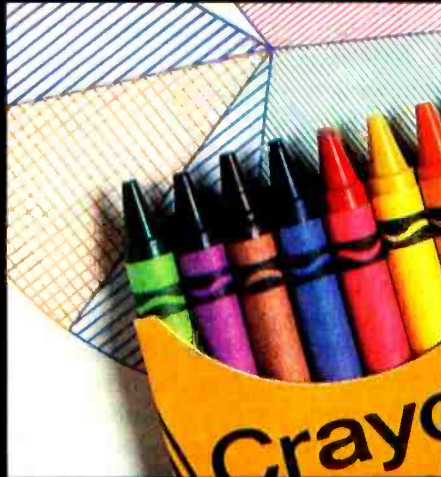

ful grids, bar graphs and pie sections. All as easy as pie!

It features an electrostatic paper-holding system for secure, high-stability plotting. An Automatic Chart Advance option for continuous, un-attended plotting. And three available interfaces — 8-bit parallel, RS232C serial and GP-IB — for compatibility with most common minis and micros, as well as for instrumentation graphics.

For complete details, write or call today: Panasonic Industrial Company, Information Systems Group, One Panasonic Way, Secaucus, NJ 07094; (201) 348-5337. In Chicago call (312) 981-4824.

The Panasonic intelligent plotter.



1-Year Limited Warranty.

Panasonic
Industrial Company

Circle 350 on Inquiry card.

The text of tel is

```
for i
do grep $i </usr/lib/telnos; done
```

The default in list for a for loop is the positional parameters. The command

```
tel fred bert
```

prints those lines in /usr/lib/telnos that contain the string fred, followed by those lines that contain bert.

You can use procedures to tailor the command environment to your needs. Because procedures are text files requiring no compilation, they are easy to create and maintain. The capability to try out parts of a procedure at a terminal helps in debugging. To further assist debugging, the shell provides two tracing mechanisms. If a procedure is invoked with the -v flag, as in

```
sh -v proc
```

the lines of proc are printed as they are read. This is useful when checking procedures for syntactic errors, particularly in conjunction with the -n flag, which suppresses command execution. An execution trace is specified by the -x flag and causes each command to be printed as it is executed. When errors in the flow of control are suspected, the -x flag is more useful than -v.

During the execution of a procedure, the standard I/O is left unchanged, allowing procedures to be used as filters. However, commands sometimes require inline data. A special input redirection notation, <<, is used to achieve this effect. For example, the editor takes its commands from the standard input. At a terminal,

```
ed file
```

calls the editor and reads editing requests from the terminal. Within a procedure, this is written

```
ed file <<!
editing requests
!
```

The lines between <<! and ! are called a *here* document; they are read by the shell and made available as the standard input to the command being executed. The string ! is arbitrary; a line that consists of the string following << terminates the document. There are a number of advantages to making "here" documents explicitly visible. The number of lines read from the procedure is under the control of the procedure writer, enabling a procedure to be understood without having to know what commands such as ed do. Furthermore, because the shell is the first to see such input, parameter substitution can be optionally applied to the text of the document.

Control Flow

The case and for constructs provide for data-driven branching and looping. The for loop notation is recognized by the shell and has the general form

```
for name in w1 w2 . . .
do command-list
done
```

A *command list* is a sequence of one or more simple commands separated or terminated by a newline or ; (semicolon). Furthermore, reserved words like do and done are normally preceded by a newline or ;. A shell variable called *name* is set to the words w1 w2 . . . in turn each time the command list following do is executed. If in w1 w2 . . . is omitted, the loop is executed once for each positional parameter; that is, in \$* is assumed.

Another example of the use of the for loop is the create command

```
for i do >$i; done
```

The command

```
create alpha beta
```

ensures that two empty files, alpha and beta, exist and are empty. The notation >file may be used on its own to create or to clear the contents of a file. Also note the ; (or newline) required before done. The notation <file

may also be used to test for the existence of a file.

A multiple-way branch is provided by the case notation. For example,

```
case $# in
  1) cat >>$1 ;;
  2) cat >>$2 <$1 ;;
  *) echo usage: append [ from ] to ;;
esac
```

is an append command. (The command to end the case statement is esac, "case" spelled backward.) When append is called with one argument, as in

```
append file
```

\$# is the string 1 and the standard input is copied onto the end of file using the command cat >>\$1.

```
append file1 file2
```

appends the contents of file1 onto file2. If the number of arguments supplied to append is other than 1 or 2, a message indicating proper usage is printed.

The general form of the case command is

```
case word in
  pattern) command-list ;;
  . . .
esac
```

each branch being terminated by ;;. The ;; preceding esac is optional.

The shell attempts to match word with each pattern in the order the patterns appear. If a match is found, the associated command list is executed, and execution of the case is complete. Because * is the pattern that matches any string, it can be used for the default case. Caution: no check is made to ensure that only one pattern matches the case word. The first match found defines the set of commands to be executed. Below, the commands following the second * will never be executed.

```
case $# in
  *) . . . ;;
  *) . . . ;;
esac
```

SuperSoft BASIC Compiler

for CP/M-86[®], MS DOS, and PC DOS

Compatible with Microsoft BASIC

The SuperSoft BASIC compiler, available under CP/M-86 and MS DOS, is compatible with Microsoft* BASIC and follows the ANSI standard. If you want to compile BASIC programs under CP/M-86, PC DOS, and MS DOS, SuperSoft's BASIC compiler is the answer.

Greater accuracy with BCD math routines

If you have used other languages without BCD math, you know how disconcerting decimal round off errors can be. For example:

**With IBM PC*
BASIC**

```
10 A=.99  
20 PRINT A  
30 END
```

Output: .9899999

**With SuperSoft
BASIC with
BCD math**

```
10 A=.99  
20 PRINT A  
30 END
```

Output: .99

As you can see, SuperSoft BASIC with BCD provides greater assurance in applications where accuracy is critical.

SuperSoft's BASIC is a true native code compiler, not an intermediate code interpreter. It is a superset of standard BASIC, supporting numerous extensions to the language. Important features include:

- Four variable types: Integer, String, and Single and Double Precision Floating Point (13 digit)
- Full PRINT USING for formatted output
- Long variable names
- Error trapping
- Matrices with up to 32 dimensions
- Boolean operators OR, AND, NOT, XOR, EQV, IMP
- Supports random and sequential disk files with a complete set of file manipulation statements
- IEEE floating point available soon as an option

In addition, SuperSoft BASIC has no run time license fee. SuperSoft's line of fine language compilers includes FORTRAN, BASIC, C, and Ada.

Requires: 128K memory
BASIC compiler: \$300.00

SUPERSOFT LANGUAGES: THE STANDARD OF EXCELLENCE.

Circle 446 on inquiry card.

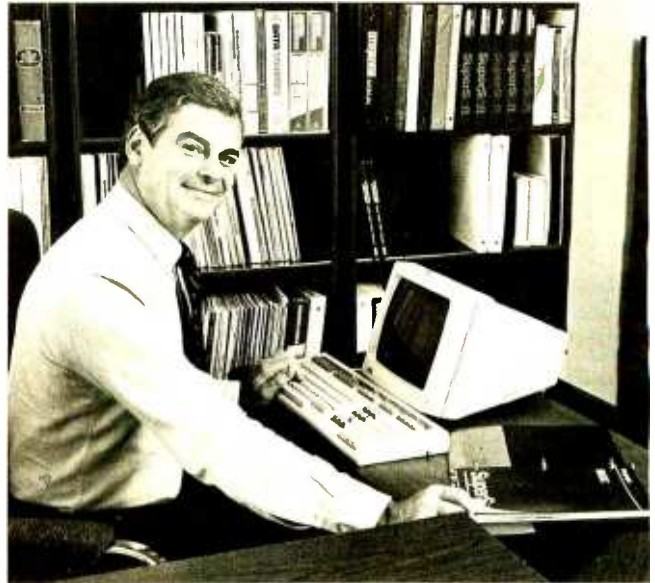

SuperSoft BASIC lets me run compiled BASIC programs under either CP/M-86 or MS DOS.

*SuperSoft BASIC is compatible with Microsoft BASIC interpreter and IBM PC BASIC. Due to version differences and inherent differences in compilers and interpreters some minor variations may be found. Machine dependent commands may not be supported. The vast majority of programs will run with no changes.

Japanese Distributor: ASR Corporation International, 3-23-8, Nishi-Shimbashi, Minato-Ku, Tokyo 105, Japan. TEL. (03)-4375371. Telex: 0242-2723.

European Agent: SuperSoft International Ltd., 51 The Pantiles, Tunbridge Wells, Kent, England TN2 5TE. TEL. 0892-45433. Telex: 95441 Micro-G.

SuperSoft[®]

FIRST IN SOFTWARE TECHNOLOGY P O Box 1628 Champaign, IL 61820 (217) 359-2112 Telex 270365

Microsoft is a trademark of Microsoft Corporation.
IBM PC is a trademark of International Business Machines Corporation.
CP/M is a registered trademark of Digital Research.

BYTE October 1983 193

PROCESS CONTROL

(TAURUS ONE) + (YOUR PC) = (PROCESS CONTROL SYSTEM)

Now a new micro computer based data acquisition and control front end that gives you:—

Power that's easy to use:— Plugs into any RS232C, RS422, or IEEE 488 port on your Personal Computer • Powerful Command functions that include: simple reads and writes, high speed block analog reads, pulse counting, frequency, change of state detection, direct thermocouple input, and more • Results in engineering units • Convenient screw terminal panels • Compatible isolated AC/DC 3 amp switchers and isolated input sensing •

Power that's easy to cost justify:—

A full range of input output modules provide: 12 bit analog inputs with 4 programmable ranges for inputs from $\pm 10\text{mV}$ to $\pm 10\text{V}$, digital I/O, counters, pulse output, 12 bit analog output, 4-20 MA input/output, thermocouples • Stand alone mode with direct terminal support • Remote operation • Communicates simultaneously to three computers • Internal diagnostics •

Power that's easy to expand:— Plug in expansion to 1024 points • User memory allows downline load of user written functions and programs • EPROM space for special user functions • Rack mount hardware available for all options •

TAURUS ONE®

Write or call for more information to:

 **TAURUS
COMPUTER
PRODUCTS
INC.**

IN U.S.A.

C/O I.M.S.
P.O. BOX 1663
BUFFALO, N.Y.
14203
(603) 673-6662

IN CANADA

P.O. BOX 911
STATION "U"
TORONTO, ONT.
M8Z 5P9
(613) 226-5361
TELEX: 053-3577

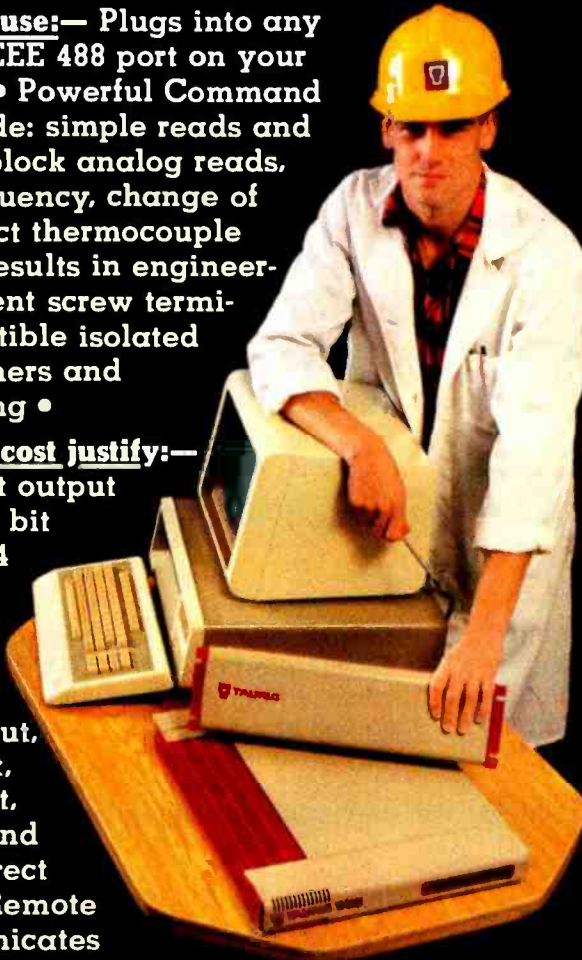

The case construction can also be used to distinguish different forms of an argument. The following example is a fragment of a cc command.

```
for i
do case $i in
  -(ocs)) ... ;;
  -* ) echo unknown flag $i ;;
  *.c) /lib/c0 $i ... ;;
  *) echo unexpected argument $i ;;
esac
done
```

To allow the same commands to be associated with more than one pattern, the case command provides for alternative patterns separated by a |. For example,

```
case $i in
  -x|-y) ...
esac
```

is equivalent to

```
case $i in
  -(xy)) ...
esac
```

The usual quoting conventions apply; thus

```
case $i in
  \?) ...
esac
```

matches the character ?.

When a command finishes execution, it returns an *exit status* (return code). Conventionally, a zero exit status means the command succeeded; nonzero means it failed. This Boolean value can be tested using the if and while constructs. The general form of the conditional branch is

```
if command-list
then command-list
else command-list
fi
```

The else part is optional. The value tested by if is that of the last simple command in the command list following if. Because this construction is bracketed by if and fi, it may

← Circle 459 on inquiry card.

SuperSoft's NEW C Compiler

... when quality counts.



In 1982 SuperSoft helped C programmers around the world move their applications from 8 to 16 bit operating systems with the first C compiler under CP/M-86®, PC DOS, and MS DOS.

With SuperSoft's new release of version 1.2.6, with its enhancements, upgrades, and improvements SuperSoft is helping those programmers stay ahead of the pack. SuperSoft was there when it counted in 1982 and will continue to be there for you in the future. Today there are several C compilers on the market, and you can look at them all. But if you want a C that's fully portable, syntactically compatible with UNIX version 7 C, rigorously tested, fast in both compilation and execution, packed with more library functions than any other, and produces a very highly optimized assembly code...then you'll find only one. The SuperSoft C compiler.

Professional Quality

Recently companies have been scrambling to catch up by releasing C compilers. SuperSoft started working on C over three years ago, and the work has never stopped. While others were struggling to put in features, SuperSoft was refining and polishing...adding the quality professionals depend on.

Thoroughly Tested

SuperSoft C has been tested with hundreds of commercial application programs. And all this testing has paid off...with a compiler that's highly reliable in every phase of operation.

Portable

SuperSoft C is now available in most operating system environments. Since we don't sell operating systems, we can support them all. And as new operating systems become popular, SuperSoft C will be there.

Packed with Library Functions

SuperSoft now has the most complete set of library functions available. All provided with source code.

Thorough User Manual

The new user manual is extensive—jammed with thorough explanations to help you every step of the way. And our technical hotline can help answer any additional questions.

SuperSoft's line of fine language compilers includes Fortran, BASIC, Ada, and C.

So when quality counts, think SuperSoft.

SuperSoft C, CP/M version: \$275.00
all other versions: \$500.00

SuperSoft®

FIRST IN SOFTWARE TECHNOLOGY P.O. Box 1628 Champaign, IL 61820 (217) 359-2112 Telex 270365

Japanese Distributor:

ASR Corporation International, 3-23-8, Nishi-Shimbashi, Minato-Ku, Tokyo 105, Japan.
Tel. (03)-4375371. Telex: 0242-2723.

European Distributor:

SuperSoft International Ltd., 51 The Pantiles, Tunbridge Wells, Kent, England TN2 5TE.
Tel. 0892-45433. Telex: 95441 Micro-G.

UNIX is a trademark of Bell Laboratories
CP/M-86 is a trademark of Digital Research

be used unambiguously in any position that a simple command may be used. This is true of all the control-flow constructions. Furthermore, in the case of if there is no dangling else ambiguity. Apart from considerations of language design, this is important for interactive use. A C-language style if ... then ... else, in which the else is optional, involves looking ahead to see if the else is present. In this case, the shell is incapable of determining that the if construct is ended until the next command is read.

The conditional AND and OR operators are also provided for testing the success of a command; they are written && and ||, respectively.

```
command1 && command2 (1)
```

executes *command₂* only if *command₁* succeeds. It is equivalent to

```
if command1
then command2
fi
```

Conversely,

```
command1 || command2 (2)
```

executes *command₂* only if *command₁* fails. The value returned by these constructions is the value of the last command executed. Thus (1) returns true if and only if both *command₁* and *command₂* succeed, whereas (2) returns true if and only if either *command₁* or *command₂* succeeds.

The while loop has a form similar to if.

```
while command-list1
do command-list2
done
```

Command-list₁ is executed and its value tested each time around the loop. This provides a notation for a break in the middle of a loop, as in

```
while a; b
do c
done
```

First a, then b, is executed. If b returns false, the loop exits; otherwise, c is executed and the loop

resumes at a. This deals with many loop breaks, but break and continue are also available. Both take an optional integer argument specifying how many levels of loop to break from or at which level to continue, the default being considered one level.

Variables

The shell provides string-valued variables that may be used within shell procedures and interactively as abbreviations for frequently used strings. Variable names begin with a letter and consist of letters, digits, and underscores.

Variables may be given values by an assignment or when a procedure is invoked. An argument to a procedure of the form *name=value* causes *value* to be assigned to *name* before execution of the procedure begins. The value of *name* in the invoking shell is not affected. Such names are sometimes called keyword parameters.

Keyword parameters may be exported from a procedure by saying

```
export user box
```

IBM PC-8087 SUPPORT FROM MICROWARE

87FORTRAN/RTOS™ is a full ANSI-77 subset with 8087 extensions. It generates in line 8087 code allowing use of all 8087 data types, including 32, 64 and 80 bit reals and 64 bit integers. The complete subset I/O is supported including Internal and External Files and List Directed I/O. Extensions include recursive subroutines, interrupt handlers and the generation of software interrupts. 87FORTRAN/RTOS uses the Intel large memory model, allowing data/code structures which utilize the full megabyte. The compiler provides direct access to 8088 ports and supports logical operations on 8 and 16 bit operands normally treated in assembly language. 87FORTRAN/RTOS is ideal for applications which are number intensive or control hardware. 95% of all "main frame" size programs compile and run without extensive editing. The price includes support for one year and RTOS. **\$1350**

87PASCAL/RTOS™ is the most powerful compiler available to PC users at this time. It is an ISO-Standard Pascal, with 8087-8088 exceptions. These make it possible to use all the 8087 data types directly, while generating modules in one of the three Intel Memory Models. Modules produced using different memory models can be interfaced and linked. This gives the user complete control of the memory model/speed trade off characteristic of iAPX cpus. All exceptions to the ISO definition are clearly marked with a grey background in a manual which is a standard of the industry, and more readable than many tutorials. The compiler makes it possible to cause or handle interrupts. It also reads ports and performs all the tasks necessary to control iAPX-86 hardware. Use of 87PASCAL guarantees you upward compatibility with future Intel processors and languages. Includes RTOS. **\$1350**

MicroWare 8087 Products

8087-3 CHIP - in stock.....	\$223
87MACRO™ - our development package for the IBM Assembler includes a Preprocessor which translates 8087 opcodes, source for a library of code macros, and a COMPLETE function library with trigonometrics, transcendental, encoder/decoder and conversions.....	\$150
87BASIC™ - includes patches for BASCOM.COM, BASCOM.LIB and BASRUN.EXE and the MicroWare 8087 runtime routines.....	\$150
MATRIXPAK™ - assembly language matrix routines callable from any 8087 compatible IBM compiler. Allows user-specified very large matrices. Size is limited by available ram.....	\$150
87FASTPAK™ - includes one MicroWare runtime library, the 87/88 Guide, an 8087, and installation instructions.....	\$375
87/88GUIDE - an excellent tutorial on writing 8087 code and interfacing it with compilers. Full of code that runs!.....	\$30
Microsoft Fortran 3.1.....	289
Microsoft Pascal 3.1.....	289
Microsoft Business Basic Compiler.....	495
Microsoft C Compiler with Librarian.....	450
Computer Innovations CI/C86.....	345
Supersoft Fortran.....	340
Energraphics.....	235
Abstat.....	345
64K RAM Upgrade Kit.....	64
Hayes Smartmodem 1200B.....	499
Sandstar Modular Expansion Boards.....	call
Epson FX-100 or C. Itoh Printers.....	call

RTOS™ — Real Time Operating System

RTOS is a MicroWare configured version of iRMX-86, Intel's legendary real time operating system. This DOS is entirely re-entrant and provides many features found only on mainframes. It includes the Intel Assembler, ASM-86, which supports the 8086, 8087, 8088 and 80186. All modules produced by the compilers or ASM-86 are combined, loaded and managed with the Utilities LINK-86, LOC-86 and LIB-86. These products make it possible to load modules anywhere in RAM, and resolve external references between runtime modules. Overlays with a single root job are supported by the linker. Binding of modules is accomplished at link or load time. RTOS/ASM-86/LINK-86/LOC-86/LIB-86..... **\$600**

**Micro
Ware**

P.O. Box 79
Kingston, MA
02364
(617) 746-7341

**You Can
Talk To Us!**

SuperSoft FORTRAN

For CP/M-86®, MS DOS, IBM PC DOS®, and CP/M-80®

SuperSoft FORTRAN is the answer to the growing need for a high quality FORTRAN compiler running under CP/M-86 and IBM PC DOS. It has major advantages over other FORTRAN compilers for the 8086. For example, consider the benchmark program used to test the IBM FORTRAN in InfoWorld, p. 44, Oct. 25, 1982. (While the differential listed will not be the same for all benchmark programs, we feel it is a good indication of the quality of our compiler.) Results are as follows:

IBM FORTRAN:	38.0 Seconds
SuperSoft FORTRAN:	2.8 Seconds

In its first release SuperSoft FORTRAN offers the following outstanding features:

1. Full ANSI 66 standard FORTRAN with important extensions
2. Standard data types, double precision, varying string length, complex numbers
3. Free format input and free format string output
4. Compact object code and run time support
5. Special functions include string functions, dynamic allocation, time/date, and video access
6. Debug support: subscript checking, good runtime messages
7. Full IEEE floating point
8. Full 8087 support-available as option (\$50.00).

Program developers:

SuperSoft's family of FORTRAN compilers means you can write your programs once and they will run under CP/M-80, CP/M-86, and MS DOS. This lets you get your applications running fast no matter what the environment.



"At last, a FORTRAN compiler that works great on my 8086, 8087, and 8088 and Z-80 based systems!"

SuperSoft FORTRAN: available NOW and working great!

Requires: 128K with CP/M-86 or MS DOS, 32K with CP/M-80

Price: \$425 (in each environment)

In conjunction with SuperSoft, SuperSoft FORTRAN was developed by Small Systems Services, Urbana, IL, a leader in FORTRAN development.

CP/M-80 and CP/M-86 are registered trademarks of Digital Research. IBM PC is a registered trademark of International Business Machines Corp.

Japanese Distributor: ASR Corporation International, 3-23-8, Nishi-Shimbashi, Minato-Ku, Tokyo 105, Japan, Tel. (03)-4375371. Telex: 0242-2723.

European Agent: SuperSoft International Ltd., 51 The Pantiles, Tunbridge Wells, Kent, England TN2 5TE. Tel. 0892-45433. Telex: 95441. Micro-G.

SuperSoft®

FIRST IN SOFTWARE TECHNOLOGY P.O. Box 1628 Champaign, IL 61820 (217) 359-2112 Telex 270365

The current compiler allows 64K code space and 64K data space with expansion anticipated in future releases.

Do something selfish. Support the arts.

We are speaking here of business support of the arts, and what it can do for your clients, your employees and your company.

In a word, lots.

Because in addition to the rewards that the arts have to offer society, there are rewards that the arts can and will offer business. Very real, very tangible rewards. All very much in your company's self-interest.

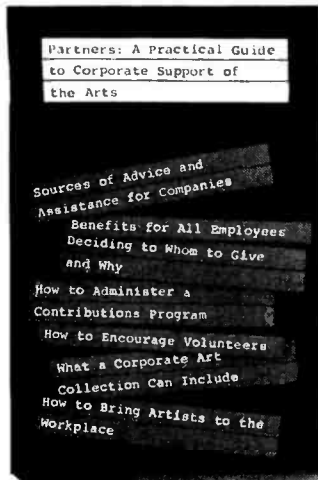

To learn how to go about getting them—or, as the case may be, how to go about it better—there's Partners.

Partners is the first practical guide to corporate support of the arts. And for anyone who has anything at all to do with the arts—or would like to—it's indispensable.

In it, you'll find dozens of examples of how business and the arts have helped—and continue to help—one another. Detailed information. No-nonsense advice. Sources to turn to for guidance. Specifics.

Partners: A Practical Guide to Corporate Support of the Arts. For more information and prices, write us today at the address below. And see how much your business can get from supporting the arts.

It's one of the few things in this world that's selfish and selfless at the same time.

Partners.

The first book on supporting the arts that doesn't leave everything to the imagination.

Partners is published by the Cultural Assistance Center, Inc., a nonprofit service organization established to promote and assist cultural institutions.

Write the Cultural Assistance Center, Inc., 330 West 42nd St., New York, N.Y. 10036.

Modification of such variables within the called procedure does not affect the values in the calling procedure. (Generally, a process may not modify the environment of its caller without an explicit request on the part of that caller. Files and shared file descriptors are the exceptions to this rule.)

A name with value intended to remain constant throughout a procedure may be declared `readonly`. The form of this command is similar to the `export` command,

```
readonly name ...
```

Subsequent attempts to set `readonly` variables are illegal.

Variables within a procedure are set by writing, for example,

```
user=fred
```

The value of a variable may be substituted by preceding its name with `$`;

```
echo $user
```

echoes `fred`. (Echo is a standard command that prints its arguments, separated by blanks.) The general notation for parameter (or variable) substitution is

```
${name}
```

and is used, for example, when the parameter name is followed by a letter or a digit. If a parameter is not set, the null string is substituted for it. Alternatively, a default string may be given, as in

```
echo ${d-}
```

which echoes the value of `d` if it is set, and `.` otherwise. Substitutions may be nested; thus

```
echo ${d-$1}
```

echoes the value of `d` if it is set; otherwise, it echoes the value (if any) of `$1`. A variable may be assigned a default value using the notation

```
 ${d=.
```

which substitutes the same string as

```
 ${d-}
```

unless `d` was not previously set, in which case it is set to the string `.` (The notation `${...=...}` is not available for positional parameters.)

When a parameter is required to be set, the notation

```
 ${d?message}
```

substitutes the value of the variable `d` if it has one; otherwise, `message` is printed, and execution of the procedure is abandoned. If `message` is absent, a standard message is printed. A procedure that requires some parameters to be set might start with

```
 : ${user?} ${acct?} ${bin?}
```

The `:` command is built-in to the shell and does nothing after its arguments are evaluated. In this example, if any of the variables `user`, `acct`, or `bin` are not set, the shell abandons execution of the procedure. Some variables have a special meaning to the shell (see table 1).

Command Substitution

Standard output from a command can be substituted in a way similar to parameter substitution. The command `pwd` prints on its standard output the name of the current working directory. If the current directory is `/usr/fred/bin`, the command

```
 d='pwd'
```

is equivalent to

```
 d=/usr/fred/bin
```

The entire string between grave accents (`'...'`) is taken as the command to be executed and is replaced with the output from the command. The command is written with the usual quoting conventions except a `'` must be escaped using `\`. For example,

```
 ls 'echo "$1"'
```

is equivalent to

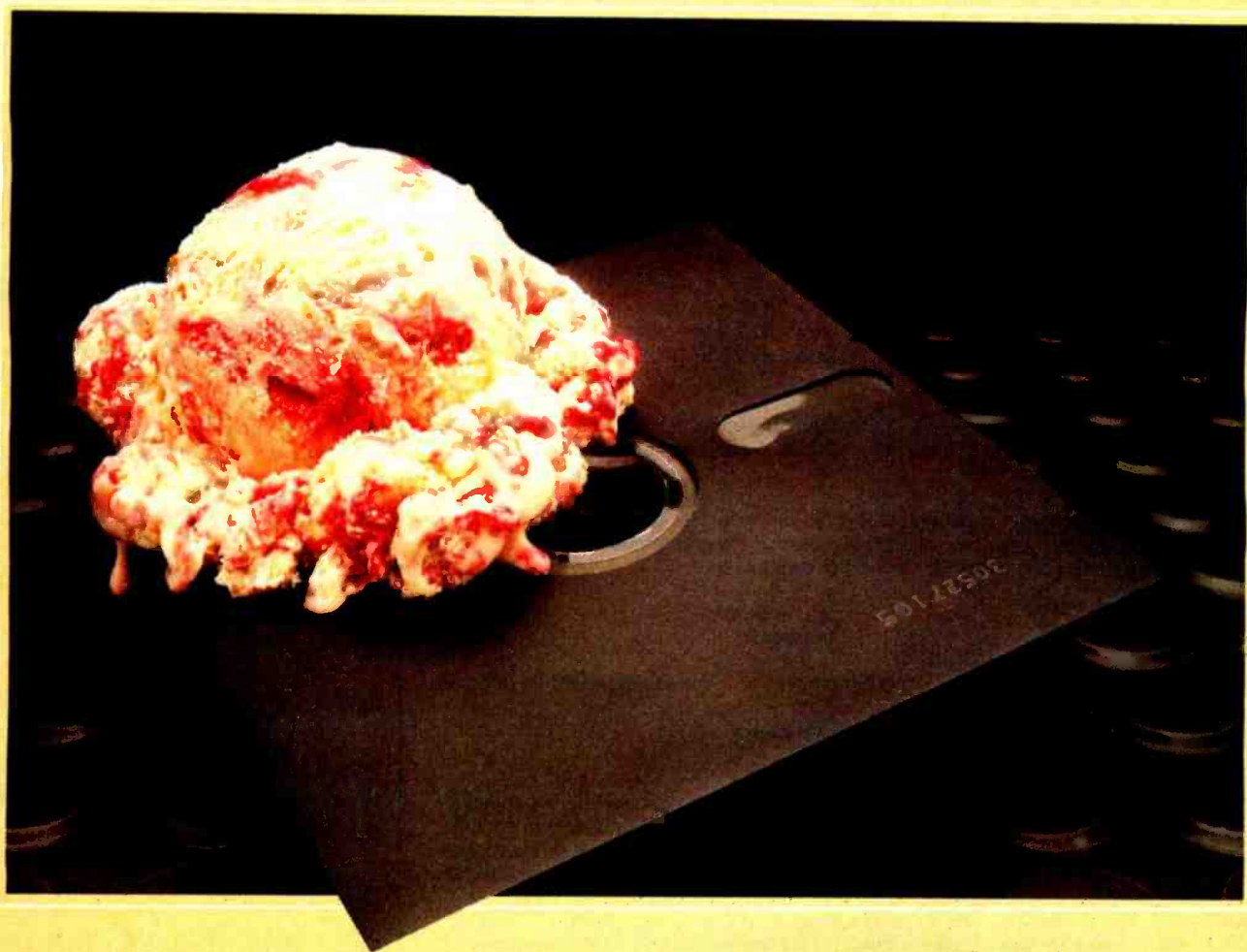

NOW THERE ARE TWO WAYS TO MAKE dBASE II A TREAT. (ONLY ONE IS GUARANTEED.)

Let Autocode write your programs for you.

For those of you with no desire to join the ranks of computer programmers just to get your work done, treat yourself to Autocode. Autocode is the easiest, fastest way to get what you want from dBase II, because it generates complete, high quality programs from simple instructions. Whether you're a dBase II master or just learning, you'll like the way Autocode writes powerful, elegant code with a minimum of effort. And you'll appreciate the fact that Autocode, unlike slower, less capable program generators, supports sophisticated dBase II features like on-screen calculations and multi-tiered criteria for report generation.

dBase II is a registered trademark of Ashton-Tate.
Autocode I is a trademark of Stemmos Ltd.

Even if you're an experienced programmer, the consistent quality of Autocode's programs will win you over.

Use Autocode without risk.

Give it a try. For only \$195.00, you get the unabridged Autocode disk and our concise, entertaining, clearly written manual. We're so sure you'll like the simplicity of Autocode's easy to use menu-driven operation, the only risk is that you'll never go back to dBase II alone. So for a taste of the best thing that's ever happened to dBase II, try Autocode. Contact your dealer, or call toll-free 800-262-8800 or (415) 777-3800. Or write Axel Johnson Corporation, 666 Howard St., San Francisco, California 94105.

Autocode I

☆ A member of the Axel Johnson Group.

Command substitution occurs in all contexts in which parameter substitution occurs (including "here" documents) and the resulting text is treated the same in both cases. This mechanism allows string processing commands to be used within shell procedures. An example of such a command is `basename`, which removes a specified suffix from a string. For example,

```
basename main.c .c
```

prints the string `main`. The following fragment from a `cc` command illustrates the use of `basename`.

```
case $A in
...
*.c) B='basename $A .c'
...
esac
```

sets `B` to the part of `$A` with the suffix `.c` stripped. Here are some composite examples:

```
for i in `ls -t`; do ...
```

The variable is set to the names of files in time order, with the most recent files first.

```
set `date`; echo $6 $2 $3, $4
```

Print the date arguments in the order specified, e.g., `1970 Feb 3, 11:59:59`. The output from `date` is `Tue Feb 3 11:59:59 GMT 1970` and the shell breaks up this output as arguments for the `set` command. The result is assigned to the positional parameters.

```
a='expr $a + 1'
```

Increment the shell variable `a` by 1 using the output from the `expr` command.

Evaluation and Quoting

The shell provides parameter substitution, command substitution, and filename generation for the arguments to commands. Let's look at the order in which substitutions occur and the effects of quoting mechanisms.

(a)

\$? The exit status (return code) of the last command executed as a decimal string. Most commands return a zero exit status if they complete successfully and return a nonzero exit status otherwise. Testing the value of return codes is deferred until the section on `if` and `while` commands.

\$0 The name of the command procedure being executed. This variable can be used to distinguish cases when a command has more than one name. For example, the following script is called `tlytek` and a link to the same file exists called `tlyblit`. If the file has any other name, and is executed by that name, the default case applies. The command sets terminal options using the `stty` command

```
case $0 in
tlyblit) stty erase ^H kill @ ffo tabs ;;
tlytek) stty erase ^H kill @ tek -tabs ;;
*)      stty erase ^H kill @ ;;
esac
```

\$# The number of positional parameters (in decimal); used, for example, in the `append` command to check the number of parameters. `$#` is also updated by the `set` command.

\$\$ The process number of this shell (in decimal). Because process numbers are unique among all existing processes, this string is frequently used to generate temporary filenames. For example,

```
ps a >/tmp/ps$$
rm /tmp/ps$$
```

\$! The process number of the last process run in the background (in decimal).

\$- The current shell flags, such as `-x` and `-v`.

(b)

\$MAIL When used interactively, the shell looks at the file specified by this variable before it issues a prompt. If the specified file has been modified since it was last looked at, the shell prints the message you have mail before prompting for the next command. For user `fred`, this variable is set as `MAIL=/usr/spool/mail/fred`

\$HOME The default argument for the `cd` command. The current directory is used to resolve filename references that do not begin with a `/` and is changed using the `cd` command. For example, `cd /usr/fred/bin` makes the current directory `/usr/fred/bin`. `cd` with no argument is equivalent to `cd $HOME`

\$CDPATH The list of directories searched by `cd`. Each directory name is separated by `:`. A typical setting of this variable, `CDPATH=.:$HOME/desk` specifies that `cd` should search the current directory, the parent directory, `..`, and `$HOME/desk`. If the directory `./src` exists, and there is no `src` directory in the current directory, `cd src` changes the directory to `./src` and prints this string as confirmation.

\$PATH A list of directories that contain commands (the search path). Each time a command is executed by the shell, a list of directories is searched for an executable file. If `$PATH` is not set, the current directory, `/bin`, and `/usr/bin` are searched by default. `$PATH` consists of directory names separated by `:`. For example, `PATH=.:/bin:$HOME/bin:/bin:/usr/bin` specifies that the current directory (the one before the first `:`), `/bin`, `$HOME/bin`, `/bin`, and `/usr/bin` are to be searched in that order. In this way, individual users can have their own commands in `$HOME/bin` accessible independently of the current directory. The directory `./bin` allows access to any directory named `bin` from the current directory. This separates commands from data files within a directory associated with some project or activity. If the command name contains a `/`, the directory search is not used; a single attempt is made to execute the command. The form `./cmd` may be used to bypass the search path for command in the current directory.

\$PS1 The primary shell prompt string, by default, `$`.

\$PS2 The shell prompts with `$PS2` when more input is needed; by default, the value is `>`.

\$IFS The set of characters used for blank interpretation.

Table 1: Variables that have special meaning to the shell. In table 1a, the variable `$?` is set after each execution of a command; all others are set initially by the shell. The variables in table 1b are typically set in the file `.profile` in the user's home directory.

Now for a limited time only new Wizard controllers. Available only through participating dealers.

Getting more out of...



Your IBM PC

Wizard-Spooler Full Feature Print Spooler Card. Same board supports parallel and serial printers. 16K buffer with 32K or 64K optional. Lets you run the next task while old task is printing.

Wizard PC Memorycard Gives you up to 256K of memory on a single plug-in-and-run board. Increases computing efficiency and helps you achieve more of the real potential of your PC.

Your Apple

Wizard BPO 32K Buffered Printer Output. Lets you continue using your Apple while the printer prints. BPO Parallel and SBO Serial for parallel or serial printers. Graphics, and text formatting, of course.

Wizard IPI Intelligent Printer Interface. Realize your parallel printer's full capabilities for text printing, text formatting and graphics.

Wizard EBI Epson Buffered Interface. For Apple, IBM PC and other computers. It mounts completely inside any MX or FX Series printer and gives you up to 64K of buffering so your computer won't be tied up while the printer is printing. EBI-Serial and EBI-Parallel for serial or parallel printers.

Wizard plug-in performance products have been designed by Wesper Microsystems to help you get more out of your personal computer. Manage your computer, instead of letting it manage you!

All Wizard products are covered by a two-year factory warranty. And they're available at all fine computer stores.

 **WESPER
MICROSYSTEMS™**

A WESPERCORP COMPANY

14321 New Myford Road, Tustin, CA 92680 (714) 730-6250

Before a command is executed, the following evaluations occur.

- parameter substitution, e.g., \$user
- command substitution, e.g., `pwd`

Substituted strings are not re-scanned. For example, if the value of the variable X is the string \$y, then

echo \$X

echoes \$y.

After these substitutions have occurred, the resulting characters are broken into words (blank interpretation); the null string is not regarded as a word unless it is quoted. For example,

echo ''

passes on the null string as the first argument to echo, whereas

echo \$null

calls echo with no arguments if the variable null is not set or is set to the

null string. Each word is then scanned for the file pattern characters *, ?, and [..], and an alphabetical list of filenames is generated to replace the word. Each such filename is a separate argument.

Metacharacters such as <, >, *, ?, |, and & have a special meaning. Any character preceded by a \ is quoted and loses its special meaning, if any. The \ is ignored; thus

echo \?\\

echoes ?\ . To allow long strings to continue beyond one line, the sequence \newline is ignored.

A \ is convenient for quoting single characters. When more than one character needs quoting, the above mechanism is clumsy and error prone. A string of characters may be quoted by enclosing part of the string between single quotes, as in

echo '*'

The quoted string may not contain a single quote.

A third quoting mechanism uses double quotes and prevents interpretation of some, but not all, meta-characters. Within double quotes, parameter substitution and command substitution occur, but filename generation and the interpretation of blanks do not. The characters in table 2 have a special meaning within double quotes and may be quoted using \ . For example,

echo "\$x"

passes the value of the variable x to echo, whereas

echo 'x'

passes the string \$x to echo.

In cases requiring more than one evaluation of a string, the built-in command eval may be used. The eval command reads its arguments (which have therefore been evaluated once) and executes the resulting command(s). If the variable X has the value \$y, and if y has the value pqr,

Graphics for the IBMpc Apple II

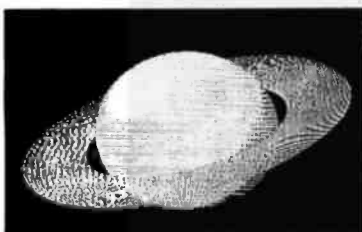

This is a spectacular collection of graphics programs for the IBMpc and the Apple II or Iie. It contains more than 60 programs in BASICA. They're listed beside theory and equations in a 280 page self-teaching guide. An optional program disk is available.

These programs will show you how to write your own 2D and 3D graphics software and they will give you many useful, ready-to-run graphics routines to incorporate in your own software.

Programs are menu driven and modular. They show how to use elementary graphics commands and do 2D and 3D translation, rotation, scaling, clipping, windowing, hidden line removal, shading, perspective, hi-speed animation, with applications to science, business, engineering and games. Adopted as a text in many leading universities. We know you will be pleased.

Please send:

IBMpc Book- \$30.50 IBMpc BASICA Disk- \$21.50

Apple Book- \$30.50 Applesoft Disk- \$21.50

Name _____

Address _____

City/State/Zip _____

check enclosed visa/mastercard

card no. _____ expiration date _____

call (617)934-0445 for faster delivery

KERN PUBLICATIONS • P.O. Box 1029B • Duxbury, MA 02332

Designer^{3D}

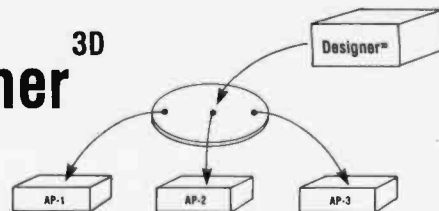

This is a professional 3 dimensional graphics design program. With Designer^{3D} you can interactively create 3D drawings on the screen, rotate in 3 dimensions, enlarge, view in perspective, store on disk, recall and update.

Run Designer^{3D} - a cursor appears on the screen with a set of 3 dimensional coordinate axes. Move the cursor around in 3 dimensions identifying node points, lines and points defining curves. Curves fit through points using a cubic spline algorithm. See your 3D picture being created on the screen. X,y,z coordinates are displayed as the cursor moves. Then enlarge, rotate, store your 3D picture on disk, recall and modify.

The picture stored on disk is a text file of node x,y,z coordinates and the lines and curves comprising the 3D object. Interface Designer^{3D} to other programs through this disk file. Use Designer^{3D} as a graphics pre-processor for your own applications software.

Designer^{3D} is supplied on disk in machine language with a user's manual. Perfect for CAD/CAM applications.

Please send Apple Designer^{3D}- \$85

IBMpc Designer^{3D}- \$85

Name _____

Address _____

City/State/Zip _____

check enclosed visa/mastercard

card no. _____ expiration date _____

call (617)934-0445 for faster delivery

KERN PUBLICATIONS • P.O. Box 1029B • Duxbury, MA 02332

then

eval echo \$X

echoes the string pqr.

Errors and Faults

The treatment of errors depends on the type of error and on whether the shell is being used interactively. An interactive shell is one with I/O connected to a terminal. Execution of a command may fail for any of the following reasons:

- I/O redirection fails because a file does not exist or cannot be created; in this case, the command is not executed
- the command itself does not exist or is not executable
- the command terminates abnormally; for example, with a "memory fault"
- the command terminates normally but returns a nonzero exit status

In all of these cases, the shell goes on to execute the next command. Except

\$	parameter substitution
'	command substitution
"	ends the quoted string
\	quotes the special characters
	\$, ', ", \

Table 2: These characters have special meaning when enclosed in double quotes; they should be quoted using \.

for the last case, an error message is printed.

All remaining errors cause an exit from a procedure. An interactive shell returns to read another command from the terminal. Such errors include

- syntax errors; e.g., if... then... done
- a signal such as terminal interrupt; the shell waits for the current command, if any, to finish execution and then either exits or returns to the terminal
- failure of any of the built-in commands, such as cd

If any error is detected, the flag -e

causes the shell to terminate.

Procedures normally terminate when an interrupt is received from the terminal. An interrupt is communicated to a process as a signal. If cleaning up (e.g., removing temporary files) is required, the built-in command trap is used.

```
trap 'rm /tmp/ps$$; exit' 2
```

sets a trap for terminal interrupt (signal 2) and, if this interrupt is received, executes the commands

```
rm /tmp/ps$$; exit
```

Another built-in command is exit, which terminates a procedure. The exit is required in the preceding example; otherwise, after the trap is taken, execution resumes at the place where interrupted.

Signals can be handled by a process in one of three ways. They can be ignored, in which case the signal is never sent to the process; they can be caught, in which case the process must decide what to do; or they can

Business Scientific Data Plotting

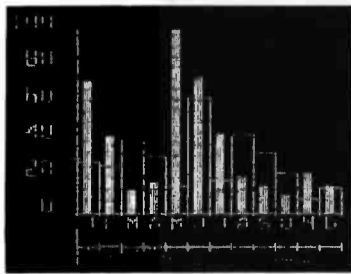

Data Plotting Software for Micros- This 232 pg book/disk package contains 18 programs in BASIC for processing and plotting data: Histograms, pie charts, log plots, regression, statistical analysis, curve fitting, barcharts, stock market charts, 3D views of surfaces, data management, applications to science, engineering and business.

Special features include writing text over graphics, automatic scaling and axis labeling, automatic replotting when data is changed.

Book contains program listing in Applesoft BASIC with theory, equations and full documentation. Disks contain same programs in Applesoft BASIC or IBMpc BASICA. Use the programs as-is or modify and combine for your own special applications.

- Please send Book- \$30.50
 Applesoft Disk- \$19.95
 IBMpc BASICA Disk- \$19.95

Name _____
Address _____
City/State/Zip _____

- check enclosed visa/mastercard

card no. _____ expiration date _____

call (617)934-0445 for faster delivery

KERN PUBLICATIONS • P.O. Box 1029B • Duxbury, MA 02332

Applied Statistics for Micros

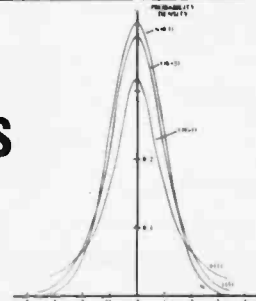

Applied Statistics for Microcomputers- This is a package of professional level statistics programs for use in business, science and engineering. Book contains program listings in BASIC alongside theory and documentation. Optional disk contains same programs in BASIC.

Book gives clear, easy-to-read tutorial on errors, statistical distributions, hypothesis tests, variance, covariance, regression, response surfaces and time series. 22 programs calculate normal, chi-square, t and F distributions; variance with randomized blocks, Latin squares, factorials, response surfaces. Hi-accuracy multi-linear regression program has data handling and transformation. Also programs for hypothesis testing, sorting and smoothing. Numerous practical applications.

Assumes no prior knowledge of statistics. Used as a text for years at a leading university.

- Please send: Book- \$38
 IBMpc BASICA Disk- \$26 Applesoft Disk- \$26 CP/M86 Disk- \$26

Name _____
Address _____
City/State/Zip _____

- check enclosed visa/mastercard

card no. _____ expiration date _____

call (617)934-0445 for faster delivery

KERN PUBLICATIONS • P.O. Box 1029B • Duxbury, MA 02332

ALPHA OMEGA

COMPUTER PRODUCTS

ALPHA OMEGA COMPUTER PRODUCTS. The beginning of fast, efficient service and low-priced computer products. The end of mail order worries.

DISKETTES

SCOTCH 3M SS DD	24
MAXELL MD2 DD DD	39

PRINTERS

CITOH 8510 PARALLEL	CALL
STAR MIC DELTA 10	CALL
OKIDATA MICROLINE 92	495
EPSON FX-80	CALL
EPSON FX-100	679

MODEMS

HAYES SMARTMODEM 300	205
HAYES SMARTMODEM 1200	495
MICROMODEM II	265

MONITORS

TAXAN 12" AMBER	122
USI PI 3 12" AMBER	139
AMDEK 300 G	133
AMDEK COLOR I 13"	274
AMDEK COLOR II 13" RGB	419

IBM PERIPHERALS & SOFTWARE

TANDON TM55-2 THIN LINE	CALL
TANDON TM100-2	235
MICROSOFT MOUSE	144
QUADRAM QUAD BOARD W/64K	273
KRAFT & T.G. JOYSTICKS	46
DBASE II	395
WORDSTAR	264
HOME ACCOUNTANT +	98
VOLKSWRITER	119
LOTUS 1,2,3	CALL
MULTIPLAN	169
FLIGHT SIMULATOR	34

APPLE PERIPHERALS & SOFTWARE

VIDEX VIDEOTERM 80 COLUMN	219
MICROSOFT PREMIUM PAK	469
MICROSOFT 16K RAMCARD	69
KRAFT & T.G. JOYSTICKS	44
QUENTIN APPLEIMATE DRIVES	235
SUPER 5 THIN LINE DRIVES	263
WIZARD BPO16K BUFFERED INT	139
EPS KEYBOARD	297
COOL & TIME (Fan, Time, Surge)	69
PFS FILING SYSTEM	82
PFS REPORT	82
DBASE II	395
WORDSTAR	239

CALL FOR COMPLETE PRODUCT LINE AND CURRENT PRICING

(213) **345-4422**

4847 LA MONTANA CIRCLE
TARZANA, CA 91356

All products are in factory sealed packages. We guarantee all items for 30 days. Within this period, defective merchandise returns must be accompanied by RMA number. All other returns will be subject to a 10% restocking fee. For prepaid orders there will be a 3% shipping charge, \$5.00 minimum. There will be an additional \$4.00 surcharge on COD orders. Cash or Cashiers Check is required on COD orders. Calif. residents add 6.5% sales tax. Prices subject to change without notice.

be left to terminate the process. If a signal is ignored on entry to the procedure by invoking the procedure in the background, trap commands (and the signal) are ignored.

A procedure itself may elect to ignore signals by specifying the null string as the argument to trap. A trap may be reset by saying, for example,

```
trap 2
```

which resets the trap for signal 2 to its default value (exit).

The procedure scan exemplifies the use of trap without an exit in the trap command. The scan command takes each directory in the current directory, prompts with its name, then executes the command typed at the terminal. Interrupts are ignored while executing the requested commands but cause termination when scan is waiting for input.

```
d='pwd'
for i in *
do if test -d $d/$i
then cd $d/$i
while echo "$i:"
trap exit 2
read x
do trap : 2; eval $x; done
fi
done
```

The command

```
read x
```

is built-in to the shell and reads the next line from the standard input and assigns it to the variable x. The command

```
test -d arg
```

returns *true* if *arg* is a directory and *false* otherwise.

To execute a command, a new process is created using the system call fork. The execution environment for the command includes I/O and the states of signals. The environment is established in the created process before the command is executed. The built-in command *exec* is used in the rare cases requiring no fork.

The environment for a command

run in the background, such as

```
list *.c | lpr &
```

is modified in two ways. First, the default standard input for this kind of a command is the empty file */dev/null*. This prevents two parallel processes, the shell and the command, from trying to read the same input. Chaos would otherwise ensue.

ed file &

allows both the editor and the shell to read from the same input at the same time. The other means of modifying the environment of a background command is to turn off the *quit* and *interrupt* signals so they are ignored by the command, thus enabling use of these signals at the terminal without causing background commands to terminate.

Summary

You should now be able to begin using the Unix shell as a programming language to write your own shell scripts. Existing Unix commands can be easily combined to create your own tools. Some of the examples shown in this article are extremely useful. I recommend that avid Unix users go on to greater proficiency with the Unix shell.

The major alternative to the standard Unix "Bourne" shell is the C-shell developed at the University of California at Berkeley. The C-shell is superior for interactive use with its aliasing, history, and job-control facilities. But if you want to write portable shell scripts that can be used on any Unix system, use of the standard Unix shell is recommended because it is available on all Unix systems. ■

Dr. Stephen Bourne is best known for his contributions to the Unix system, including the "Bourne" shell and the book The Unix System. An internationally known computer scientist with 15 years of computer systems experience, he is one of the designers of the Cambridge Capability Computer and is recognized for his contributions to programming-language design and compiler-construction techniques. Dr. Bourne can be reached at Silicon Graphics Inc., 630 Clyde Court, Mountain View, CA 94043.

Match the 68000 Competition with UNIX[™] operating systems.

Beat it with UniFLEX[™].

W

e can't keep a good thing secret. Our new UniFLEX Operating System for the 68000 is better than the competition's UNIX operating systems or like offerings. Better in several ways. A whole new generation of users can now enjoy the efficiency, flexibility, and reliability that built our reputation.

Want the full story? Call us. Or watch for more details.

There *is* a superior alternative.



Technical Systems Consultants, Inc.
111 Providence Road
Chapel Hill, NC 27514 USA

Telephone: (919) 493-1451
Telex II: 510-920-0540

UNIX[™] is a trademark of Bell Laboratories.
UniFLEX[™] is a trademark of Technical Systems Consultants, Inc.

"Training? Call a computer school."

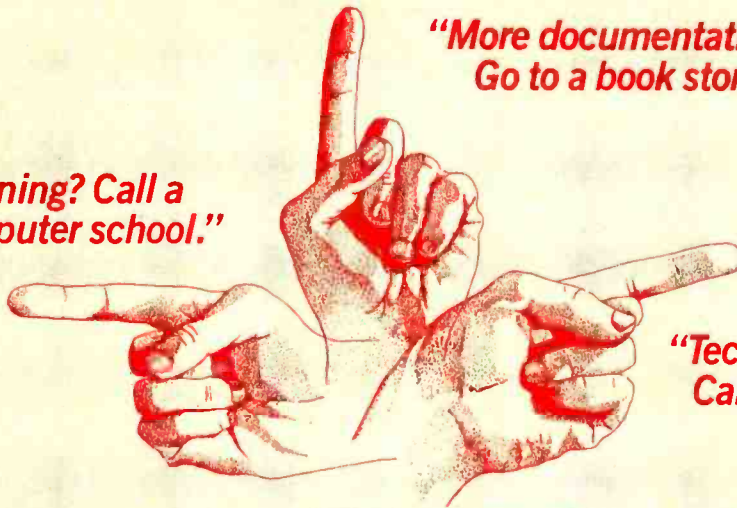

"More documentation? Go to a book store."

"Technical support? Call the publisher."

Interested in dBASE II™ or 1-2-3™? Beware The Dreaded Finger Pointers!

Sound familiar? Does your dealer turn into a "finger pointer" when you need help?

At SoftwareBanc we offer a complete system that doesn't stop when your software is delivered.

Careful Product Selection

Do you get bewildered by the endless lists of software you find in most ads? Let us be your quality control department.

We only sell the best programs on the market. After a thorough evaluation we chose dBASE II™ for data processing, and 1-2-3™ for financial management.

Our complete line of add-on products help you to continue to get the most from your software.

Expert Technical Support

When you buy software from us, you can rest assured that help is only a phone call away. Just call us at (617) 641-1235 for all the free support you need.

Money Back Guarantee

We are offering a 60 day money back guarantee on the following software: 1-2-3, dBASE II and ABSTAT. Call for details.

Free dBASE II™ User's Guide

Order dBASE II™ from us, and you'll receive a free copy of our dBASE II™ User's Guide. You can also buy the User's Guide first for only \$29, and then receive a full credit when you buy dBASE II.™

1-2-3™ & dBASE II™ Classes

Want more in-depth information about dBASE II™ or 1-2-3™? Attend a SoftwareBanc Seminar near you. Each session runs from 9 to 5, and costs \$175. Seminars are in lecture format with a custom sound & video system which is used to display taped interviews with prominent software personalities and sessions with various software programs.

Chicago
Oct. 17-21

Dallas
Nov. 14-18

San Diego
Dec. 12-16

Prices You Can Afford

†1-2-3™	\$399
†dBASE II™	\$479
†ABSTAT™	\$379
dBASE II™ User's Guide	\$29
DBPlus™	\$95
dGRAPH™	\$199
dUTIL™	\$69
dNAMES™	\$109
FRIDAY™	\$199
QUICKCODE™	\$199
TEXTRA™	\$60*

†No-risk 60 day money back guarantee
*Only available for IBM PC with MS-DOS.

Free Catalog

If you want to learn more about SoftwareBanc, call or write for our free product catalog.

SoftwareBanc

661 Massachusetts Avenue
Arlington, Mass. 02174

For technical support call:
(617) 641-1235

Dealer Inquiries Invited.

™ Manufacturer's trademark

Payment may be made by: MasterCard, Visa, check, C.O.D., money order. Mass. residents please add 5% sales tax. Add \$5.00 for shipping and handling. Prices subject to change.



Hours 9AM-8PM E.S.T.
Monday-Friday

Teach your computer who's BOSS!

Attend a dBase II or 1-2-3 SoftwareBanc Seminar

Here are just a few of SoftwareBanc Seminars' clients:

ABC	Digital Research	Price Waterhouse
Arthur Anderson	Dunn & Bradstreet	RCA
Boeing Aerospace	E.F. Hutton	Shell Oil
CBS	Fox & Geller	Smithsonian Institute
Chase Manhattan Bank	IBM	U.S. Air Force
Citibank	Internal Revenue Service	U.S. Navy
Computerland	Laventhol & Horwath	U.S. Postal Service
Cornell University	Merrill Lynch	Victor Business Products
Digital Equipment Corp.	Osborne Computer Corp.	Westinghouse
	Polaroid Corp.	Xerox



ADAM B. GREEN



Taught by the nation's leading dBASE II expert, Adam B. Green, whose dBASE II User's Guide has sold over 30,000 copies.

"Green doesn't just teach dBASE syntax, he establishes the fundamental terminology and organization behind data-base management systems."

dNEWS - Ashton-Tate

1983 Schedule of Classes

Anchorage August 11-12 Sheraton Anchorage	New York September 19-23 New York Hilton	Dallas November 14-18 AMFAC
Washington, D.C. August 29-September 2 Marriott Crystal Gateway	Chicago October 17-21 Hyatt Regency	San Diego December 12-16 Hyatt Islandia

4 Days of Instruction

9:00 A.M. to 5:00 P.M.
dBASE II Fundamentals
dBASE II Programming
Advanced dBASE II
Problem Solving with 1-2-3

State of the Art Presentation

- Video and sound system
- Buffet Lunch/Coffee Breaks
- Video tapes of program authors
- Portfolio of Comprehensive Seminar Notes

\$175 Per Day of Instruction

Pre-payment may be made by:
MasterCard, VISA or Check.
Call or write to register



SoftwareBanc Seminars
661 Massachusetts Avenue
Arlington, MA 02174
(800) 451-2502
(617) 641-1241 in MA

computers wholesale

315-472-3055

Box 150 Brewerton, N.Y. 13029

Circle 565 on inquiry card.

—TERMINALS—

ESPRIT	
Esprit.....	\$429
Esprit II.....	499
Esprit III.....	719
Esprit III (Color).....	Call
LEAR SEIGLER	
ADM 3A.....	549
ADM 5A.....	579
ADM 22.....	599
ADM 36.....	979
QUME	
102.....	555
102A (Amber).....	569
108.....	715
108A (Amber).....	729
TELEVIDEO	
910.....	479
925.....	669
950.....	859
970.....	929
WYSE	
100.....	Call
300 (Color).....	Call
ZENITH	
Z-29.....	649
ZT-10.....	399
ZT-11.....	459

—MODEMS—

HAYES		
Micro Modem 100.....	269	
Micro Modem II.....	269	
Smartmodem 300.....	199	
Smartmodem 1200.....	498	
Smartmodem 1200B.....	Call	
NOVATION		
D-Cat.....	16	
J-Cat.....	105	
Apple Cat II.....	310	
103 Smart Cat.....	199	
103/212 Smart Cat.....	475	
212 Auto Cat.....	519	
SIGNALMAN		
Mk I..... \$ 79	Mk VII..... \$ 119	
Mk III..... 99	Mk II..... 79	
Mk V..... 89	Mk VI..... Call	
NEW! Volksmodem.....		Call
U.S. ROBOODICS		
Auto Dial 212A.....	479	
Password.....	Call	

Advertised prices reflect a cash discount on prepaid orders only. Most items are in stock for immediate delivery in factory sealed cartons with full factory warranties.

—SYSTEMS—

ALDOS	
ACS-8000-10.....	\$5989
ACS-8000-12.....	7189
ACS-8000-14.....	8789
Series 5-5D.....	3990
Series 5-15D.....	2199
580-10.....	4789
586-10.....	6389
586-14.....	10,389
MTU-3.....	2000
MTU-4.....	2000
COLUMBIA	
UP Portable.....	Call
MPC.....	Call
MPC w/Hard Disk.....	Call
CROMEMCO	
C-10 Super Pak.....	1429
CS-1.....	3195
CS-1H.....	5595
CS-2.....	3755
CS-3.....	5595
64 FDC.....	475
TUART.....	255
EAGLE COMPUTER	
II E Series	
II E-1.....	II E-2
II E-3.....	II E-4
PC Series	
PC-E.....	PC-1
PC-2.....	PC-XL
1800 Series	
1620.....	1630

—Call us today for the best prices—
(Eagle Computers cannot be shipped UPS)

INTERTEC	
Superbrain II JR.....	1859
Superbrain II QD.....	2309
Superbrain II SD.....	2609
Compustar.....	Call
MORROW	
Micro Decision w/Terminal.....	
MD-1 w/1 drive & software.....	1270
MD-2 w/2 drives & software.....	1590
MD-3 w/DS drives & software.....	2010
NEC	
PC-8801A Computer.....	Call
PC-8831A Dual 5 1/4" disk drive.....	Call
NORTHSTAR	
Advantage 2Q.....	2319
Advantage 1Q HD5.....	3599
Horizon 2Q 64K.....	2399
HD 18 Mb. hard disk.....	3879
TELEVIDEO	
TS-803.....	1989
TS-802.....	Call
TS-802H.....	Call
ZENITH	
ZF-100-21.....	2319
ZF-120-22.....	2879
ZF-120-32.....	4479

—PRINTERS—

ANADEX		
DP-9501.....	\$1099	
DP-9620.....	1199	
DP-9625.....	1299	
DP-6500.....	2399	
WP 6000.....	2159	
CENTRONICS		
730-1 Parallel.....	200	
739-3 Serial.....	469	
COEX		
80 FT parallel.....	289	
C.ITOH		
Prowriter 8510A Par.....	375	
Prowriter 8510A Ser.....	575	
Prowriter II Par.....	679	
Prowriter II Ser.....	739	
DIABLO		
620 RO 25 CPS.....	919	
630 RO 40 CPS.....	1769	
EPSON		
MX-80FT.....	469	
MX-100.....	649	
FX-80.....	Call	
RX-80.....	Call	
GEMINI		
10X.....	295	
15X.....	435	
MANNESMAN TALLEY		
MT-160 I.....	529	
MT-160 L.....	599	
MT-180 L.....	Call	
NEC		
3510..... \$1490	3530..... \$1490	
3550..... 1845	7710..... 1949	
7715..... 2099	8023..... 399	
NEW NEC 2000.....		Call
OKIDATA		
ML-82A.....	389	
ML-83A.....	595	
ML-84 Par.....	979	
ML-92.....	489	
ML-93.....	839	
Pacemark 2350.....	Call	
Pacemark 2410.....	Call	
QUME		
Sprint 11/40.....	1339	
Sprint 11/55.....	Call	
SILVER REED		
EXP 500 Par.....	459	
EXP 550 Par.....	659	
EXP 550 Ser.....	689	
TEXAS INSTRUMENTS		
TI-810 Basic.....	1199	
TI-810 Package.....	1549	
TI-810 LQ.....	1919	
TI-820 Basic.....	1549	
NEW TI-850.....	Call	

—MONITORS—

AMDEK	
Color I.....	\$279
Color I +.....	319
Color II (RGB).....	399
Color III (RGB).....	349
300 G (12" green).....	135
300 A (12" amber).....	149
310 A (IBM PC).....	175
BMC	
15 MHZ (12" green).....	79
NEC	
JB-1260 (12" green).....	99
JB-1201 (12" green).....	149
JC-1212 (12" color).....	339
JC-1203 (12" RGB).....	549
ZENITH	
Z-122 (12" green).....	109
Z-123 (12" amber).....	135
Z-131 (13" color + gr.).....	299
Z-135 (RGB).....	519

—HARD DISKS—

CORVUS		
Model 6.....	2120	
Model 11.....	2970	
Model 20.....	3820	
Omninet 6.....	1950	
Omninet 11.....	2800	
Omninet 20.....	3650	
Mirror Back-up.....	670	
PERCOM		
Call for best price!		
KONAN		
SPECIAL! 5Mb. for S-100.....		1629

—DISKETTES—

3M/ Scotch
5 1/4" . . . \$21.95
(Single Sided, Double Density)

5 1/4" . . . \$30.95
(Double Sided, Double Density)

Call us for the lowest prices on other popular diskettes!

If you can't find what you need listed here, just call for the best prices on the items you require.

N.Y. residents, add appropriate sales tax. We accept VISA and Master Card. Personal and company checks, allow 2 weeks to clear. C.O.D.'s require a 25% deposit. All prices and offers may be withdrawn without notice.

Unix as an Application Environment

A tools approach to the needs of the business community

by Mark Krieger and Fred Pack

The operating system defines a computer's environment. And the first requirement of an environment is that it be reliable. Users need a robust software foundation—one that's not susceptible to a crash yet is able to exit gracefully when necessary. The system's stability should quell the need for releases of new applications, and the sponsoring organization should provide reliable support. Generally speaking, the operating system should be mature.

Users also have secondary needs. The operating system must provide a framework for its two kinds of users: the developers and the end users. Developers are most productive when they have good tools to aid the programming process. These tools include languages, debugging aids, text editors, and other utilities. End users have an entirely different set of needs. They should be isolated from the esoterica of the computer and be given something that is easy to use.

Finally, various technical features are needed:

- the ability to handle multiple users
- interprocess communication and concurrent operations so that users and their tasks can work together

- communication capability so that users on different machines can work together
- file locking so that users do not get in each others' way
- a rich set of utilities so that we are spared from having to create our own routines
- portability so that the programs we write today will continue functioning in the advanced machines available in the future
- a large body of applications so that the computer can immediately perform useful work for us

Because it meets these criteria, we believe that the Unix operating system is one of the systems of choice.

General Software Problems

Unfortunately, most designers of operating systems neglect the needs of the end user. The early designers didn't expect their systems to be used in the mass market, and later designers patterned their products after the originals to provide compatibility. Furthermore, most computer users were technically adept; system software "hand holding" wasn't necessary. Finally, until quite recently microcomputers' limited computational power kept designers from de-

voting the machine resources required to make the system software easy to use.

These historical problems are being overcome due to the dramatic drop in microcomputer prices and the increase in computer capabilities. Stated simply, a low-cost computer must not require extensive operator training. The typical computer user is someone with a problem to solve, not a computer professional.

The increased computer "horsepower," storage, and graphics capabilities that are standard today permit the system designer to make the system infinitely more pleasant to use for both computer professionals and the problem solver.

The historical problems of operating systems center on their tendency to be cryptic, unfriendly, and unstandardized. Phrasing a command precisely can require extensive study of a dense, technically oriented, and usually poorly worded system manual. Occasionally, machines respond even to proper commands with system-error-messages such as BDOS ERROR or ERR ON DEV 0/1, which are incomprehensible. The user may find that his data is lost because he forgot to issue the SYNC command when he turned off the

machine.

Integrated software application packages such as 1-2-3 from Lotus Development and Visi On from VisiCorp provide session guidance, common data and command structures, and consistent documentation. However, a fully integrated environment can be achieved only by the underlying operating system. Apple's Lisa is the first of such systems. Lisa provides extensive graphical representation, lets users issue commands without keying, and can exchange data with all the integrated applications.

Alternatives

Several operating systems are vying for a significant share of the microcomputer marketplace. The primary ones are CP/M, MS-DOS, Pick, and Unix. Lisa-style operating systems will soon be contenders.

CP/M: CP/M was the first significant microcomputer operating system. Consequently, it has the largest collection of application software. Because the older microcomputers had limited power, CP/M did not provide sophistication for either developers or users. Updated versions have added concurrency, multiuser capability, and portability. Many of CP/M's features have become de facto standards because of CP/M's popularity on 8-bit computers; however, CP/M is hampered by its limited abilities.

MS-DOS: MS-DOS, designed for the newer 16-bit machines, remains largely compatible with the command syntax of CP/M. This has proven to be a winning strategy, and MS-DOS is very successful. At this time, MS-DOS is not portable and runs only on the 8086 microprocessor family. MS-DOS is evolving to more closely resemble Unix, by mimicking the tools approach and file structure, which is so useful for program development and applications.

Pick: the Pick operating system, an applications environment, was designed around databases and query facilities, which means it is easy to use. Because it permits programming only in BASIC, it is not efficient for math or computational applications.

Of course, a good deal of data processing is concerned specifically with databases. Pick is portable and runs on a wide range of machines. Originally designed for larger machines, it has the sophisticated facilities business users demand.

Unix: the Unix operating system, designed by Bell Laboratories 10 years ago as a program-development base, originally ran on minicomputers. It is

Several operating systems are vying for a significant share of the microcomputer marketplace. The primary ones are CP/M, MS-DOS, Pick, and Unix.

very portable and has migrated both up- and down-scale. Though a fine development system, until recently Unix lacked application programs and was not for the end user. It has always provided an integrated, consistent, and powerful environment to software developers through the tools approach. We'll discuss Unix's strengths, weaknesses, and potential in greater detail later.

Lisa: the Lisa-style operating system will have a profound effect on the front-ends of all future operating systems. A Lisa user sees a graphics display with pictorial representations instead of words. He operates the system by manipulating a mouse, which moves the cursor among the pictures (or "icons"), each of which signifies a command or the data to be handled. In addition, extensive use is made of windowing, which enables the user to see several displays at once.

Mice and windows are proliferating in new application designs even for other operating systems. For instance, Multitool-Word, a new word processor from Microsoft, uses a mouse and multiple windows, as do Visi On and the Unipress EMACS extensible screen editor for Unix.

Strengths of Unix

Unix has a reputation as the best

environment for writing and maintaining programs, but it is considered a poor basis for end-user applications. We feel that the acclaim is justly deserved, but the negative sentiment is not as appropriate regarding applications use.

Unix is multiuser: because the cost of a machine is borne by several users, it can be lower than multiple single-user alternatives. Other operating systems are moving toward multiuser capability, but Unix has always had this facility.

A less obvious advantage of multiuser systems is the availability of shared data. Most applications rely on a database of some kind, and this data is usually of general interest to the user community. While networks of single-user machines can theoretically access a common data bank, in practice this is a cumbersome process.

Another inherent virtue of multiuser systems is the ability to develop software jointly. Large projects require many people, and the individually created components become integrated during the course of the project. Interim testing and final integration are greatly simplified when all the components reside on the same computer. MP/M, a member of the CP/M family, is available in a multiuser format, as is Pick. Lisa and MS-DOS 2.0 are not multiuser systems.

Multitasking capability: the process of running more than one program concurrently is another asset of the Unix system. This permits you to do more than one job at your terminal: for example, you could query a database while printing a lengthy report. Most microcomputer operating systems do not provide this capability, and even some mainframe operating systems limit the scope of multitasking. Unix has no built-in constraints on the degree of concurrent work.

Unix is the best program-development system: though most computer users are not programmers, they do rely on the programmers' creations. Thus, Unix applications can be particularly sophisticated because the development environment is so rich.

A number of standard languages are included in Unix, among them C, assembler, and FORTRAN. Pascal, COBOL, BASIC, and Ada are also available. C combines the efficiency of assembly-language with the control structures of modern high-level languages. Many applications exist for most of the other languages. Unix also provides several editors and debugging aids. The standard `ed` line editor is usually supplemented with the `vi` screen editor, which is now part of Unix System V.

The concept of reusable tools permits existing program segments to be strung together. Many applications require sorting of data, for example. Under most operating systems, the programmer must either write his own sort or obtain a commercially available one. Using this sort may be a separate job step. As one of its hundreds of built-in utilities, Unix includes a sort that can be run as a concurrent task or as a separate step. All of these utilities can interface with either terminals or files and communicate with each other. An example is the `/RDB` database package. `/RDB` is a collection of approximately 40 interacting tools that let you build a relational database without writing a single program.

An advanced file system: historically, operating systems organized files in a "flat" structure so that users' data and programs were commingled. As system complexities and disk sizes grew, flat file systems became intolerable. Unix provides a far advanced method of managing data and programs: the tree-structured file hierarchy.

In Unix, files are members of directories, which are themselves members of higher-level directories. Data and programs can therefore be organized coherently according to need. Any file or directory can be protected against unauthorized access. This protection extends to read/write/execute access for specific users, groups of users, and the entire user community. The file system is easily navigable from within programs or the command line.

Unix has extensive communications capabilities: standard Unix utilities

transfer files between computers. In addition, the communications package permits a user to pass through one computer and log into another.

Weaknesses of Unix

The most often cited criticisms of Unix are its "user unfriendliness," its tendency to destroy files when the hardware crashes, its lack of record interlock needed to permit multiple, simultaneous write access to shared data, and the lack of a body of avail-

able applications. Until recently, the Bell System seemed unconcerned with the commercial potential of its Unix product and thus did not take the steps needed to ensure its success in the marketplace.

User unfriendliness: Unix was designed for computer professionals, an audience that appreciates terse command syntax because a minimum of keystrokes are needed to get results. Thus, to copy files you enter `cp` instead of "copy." This minimalist

NOW AVAILABLE FOR IBM P.C.

DBPlus™

SORT, COMPRESS, and TRANSFORM
dBASE II™ DATA FILES

NOW AVAILABLE FOR IBM P.C.

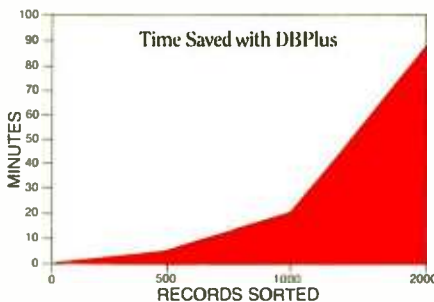

If you are serious about dBASE II™, you need DBPlus™. This program runs outside of dBASE II™ and performs the following important functions on dBASE II™ data files:

- Sort
- Compress/Decompress
- Transform

DBPlus™ is designed to free you from the chore of typing, or memorizing a new language. In most cases all you have to do is move the cursor to the next menu item and press return!

SORT

DBPlus™ can sort a data file up to 15 times faster than dBASE II™ on a single field; 32 fields may be sorted in a single pass, and each additional field requires 1% more sorting time.

COMPRESS/DECOMPRESS

A copy of any dBASE II™ data file, can be produced which is only 30% to 40% of the original size.

The compressed file will save you transmission time and phone costs, when you send a data file over a modem.

Making backup copies of large data files can use up many floppy disks. Compressed files will save you space in archival storage.

TRANSFORM

You can now modify the structure of any data file, by adding, deleting, and modifying fields, without any programming knowledge.

DBPlus™ can also create a new file which is compatible with WordStar/MailMerge.™

Now retailing for \$125.

Manual and demo available. Call for a dealer near you.

HumanSoft

661 Massachusetts Avenue
Arlington, Mass. 02174
(617) 641-1880

Dealer and distributor inquiries invited!

dBASE II is a registered trademark of AshtonTate, Inc.
WordStar/MailMerge is a registered trademark of MicroPro, Inc.
DBPlus is a registered trademark of HumanSoft

philosophy extends to the Unix manuals, which require considerable study to comprehend. Few examples are given, which further makes the system difficult to learn.

In reality, Unix is no harder to use than any command-line-oriented system. You must learn the syntax of the commands, and Unix cannot be faulted for having so many commands; these commands, after all, are what give it great power. The commands use a standard format and syntax, unlike some competing products. In addition, the development of new menu-oriented shells is making Unix more accessible to the end user. The documentation is improving considerably, and numerous books have been written on Unix, which improve the learning process.

Propensity to destroy files: the criticism goes back a few years. Because Unix uses a "write behind" file mechanism to improve disk performance, there is a risk of file corruption or data loss if the hardware is not properly turned off (e.g., dur-

ing a power failure). Such file losses occurred with regularity years ago; however, recent improvements have made Unix at least as robust as other systems.

Lack of record interlock: the lack of a record-interlock feature has been a serious impediment to widespread commercial use of Unix. Most data-processing applications require users to share a common database, and, as discussed earlier, Unix made shared

Unix comes with C and FORTRAN, and other languages are becoming available as demand increases.

data possible by its multiuser nature. Unfortunately, Unix did not protect these files against simultaneous write access, which created the risk of file degradation. Of course, application developers could arrange for their own protection, and many did. Even

so, the operating system is the best place for such protection, and Unix has not had it until recently.

The Bell System: another criticism of Unix has been that it is a creature of the Bell System, whose interests may not correspond to those of the commercial computer world. This observation has certainly been valid, and as Unix progressed (without complete upward compatibility) from Version 6 to 7, and later from System III to V, observers had the right to feel that the system was too unstable for them to rely on.

Bell has clearly responded to those objections: the royalty fee has been reduced, the company has promised that it will not make future enhancements at the expense of compatibility, and Bell Labs has begun working closely with the major hardware manufacturers so that Unix can be available in a standard manner on all the popular 16-bit microprocessors.

Unix as an Applications Base

Unix is a sound vehicle for applications programs. The body of existing, commercially available Unix applications is not yet very large because until recently few microcomputer manufacturers supplied Unix with their machines. Applications are written as authors see a new market develop, and authors can reliably be expected to service the Unix area, just as they have flooded the MS-DOS arena, which did not even exist two years ago.

For years Unix has been the primary system in many research labs and engineering firms. These centers have designed many applications for internal use, and some of these are now appearing commercially.

Languages: Unix comes with C and FORTRAN, and other languages are becoming available as demand increases. Thus, both RM and CIS COBOLs, which are very popular on CP/M systems, now exist for Unix. BASIC from Microsoft and SMC have been ported. The first Ada implementations have been for Unix because Unix offered the best development base for its authors. Pascal, BASIC, and FORTRAN from SVS are

CORVUS SYSTEMS **WE** **INTERTEC DATA SYSTEMS**

WON

THE PRICE WAR

In every battle, we came up the victors. Not only in price, but in service and support as well.

Call to order: **1-800-257-5217**
(in NJ 609-424-4700)

TRISTAR
THE NETWORKING EXPERTS

We carry:

Intertec Data Systems
Corvus Concept
Corvus Hard Disk
C. Itoh Printers

TriStar Data Systems
2 Keystone Avenue
Cherry Hill, NJ 08003
609-424-4700
215-629-1289

WE SERVICE WHAT WE SELL

NEVADA COBOL™ \$29.95

each!

A HIGH CALIBER COMPILER FOR CP/M®

Teachers praise Nevada COBOL. Extremely easy to learn, easy to use. Nevada COBOL is installed in hundreds of high schools, colleges, and universities. Its excellent documentation, 165 pages with an index, also serves as a classroom text.

And, students love Nevada COBOL. It's the affordable, easy to use COBOL. Imagine — being able to do advanced projects at home, and "no more long waits at the computer center."

Nevada COBOL. A compiler based upon the ANSI-74 standards with some level-2 features. COPY, CALL... USING... CANCEL, PERFORM ...THRU ... TIMES ... UNTIL, IF ... ELSE ... NEXT SENTENCE, AND/OR, DEPENDING ON, INSPECT, TALLYING, REPLACING. And more. Much more.

Applications Programmers proclaim Nevada COBOL the best compiler for development. It's fast. It's compact. It's portable. Better yet, you can distribute your object programs, royalty free.

Take advantage of our money back guarantee. If you are not completely satisfied, just return the package—in good condition, with the sealed diskette unopened—within 30 days, and we will refund your money.

A powerful addition to their microcomputers. Since December 1979, when we ran our first ad in *Byte* magazine, thousands of users worldwide have discovered Nevada COBOL. There's even an established Nevada COBOL Users Group!

Join them! Order now!



ELLIS COMPUTING™

ALSO AVAILABLE:

NEVADA FORTRAN™	\$29.95
NEVADA PILOT™	\$29.95
NEVADA EDIT™	\$29.95
COBOL APPLICATIONS PACKAGE BOOK 1	\$ 9.95

Commodore-64 version available from Commodore Business Machines.

MAIL TODAY! To: Ellis Computing, Inc.
3917 Noriega Street
San Francisco, CA 94122
(415) 753-0186

The CP/M® Operating System, an 8080/8085/Z80 microprocessor, and 32K RAM are required.

Software Packages: COBOL FORTRAN PILOT EDIT

Diskette Format: 8" SSSD (Standard IBM 3740 format)
5 1/4" Apple CP/M Xerox 820 (Kaypro) Osborne
 Televideo Micropolis Mod II North Star DD North Star SD
 TRS-80 Mod I with CP/M @ 4200 hex TRS-80 Mod I/Mapper
 Heath Hard (Z-89) Heath Soft (Z-90)
 Superbrain DD DOS 3.X (512 Byte sectors)

Shipping/Handling Fees. Add \$4.00 for the first package and \$2.00 for each additional package. OVERSEAS add \$15.00 for the first package and \$5.00 for each additional package. Checks must be in U.S. funds and drawn on a U.S. bank!

Send my order for _____ packages @ \$29.95 each Total _____
COBOL Applications package @ \$9.95 each Total _____
In CA add sales tax _____
Shipping/handling _____
Total _____

Check enclosed
 MasterCard Visa

_____ Exp. Date _____

Signature _____

Ship to:
Name _____

Street _____

City/State/Zip _____

available from certain hardware manufacturers.

Menu systems: the "user unfriendliness" issue has been disposed of by front-ends to Unix, which replace the command-line interpreter (shell) with a formatted screen that displays a menu. For example, Fortune and Altos Unix machines both include a menu shell. In addition, Unipress's menu system can be tailored easily either as a replacement Unix shell or as a front-end to any application. Properly configured menus can significantly reduce the learning period and error rates and guide the user.

Word processors and editors: Unix includes both word processors and text editors: the *nroff/troff* package is extremely powerful, although difficult to learn and use; the *ed* line editor has recently been supplemented with the full-screen *vi* product.

Software vendors are now providing excellent additional tools. The XED, Horizon, LEX, and the Fortune Forword word processors have features heretofore available only on dedicated word-processing machines.

EMACS is a screen editor that has migrated to Unix from its origins on DEC 10/20. This product has extraordinary powers; for example, multiple windows enable several files to be edited simultaneously, and a built-in compiled MLISP programming language provides great extensibility.

Spreadsheets: the microcomputer age was to an extent built upon the spreadsheet. Such programs are now available for Unix. The Unix environ-

ment is so powerful that spreadsheets like Ultracalc have no practical limits on the numbers of rows or columns. Unicalc is compatible with Visicalc and Supercalc. Both these spreadsheets are written in C, so they can be placed easily on any Unix machine. Multiplan is also available.

Database and ISAM: because Unix itself does not provide a keyed file mechanism, products have been written to fill this need. (Only Pick has been designed with a built-in database.) A variety of modern relational databases are now available. Mistress, Informix, Unify, Ingress, and /RDB are all tailored for Unix. Some of them also support query languages.

Programmers often want to access data based upon a key or index, without needing a full database system. The Phact ISAM (indexed sequential-access method) system from Unipress enables the C language programmer to build and maintain sophisticated multi-index, variable-length record, ISAM files. The Informix package also has an ISAM system.

Emulators: because so much software is designed for the older 8080/Z80 CP/M computers, several Unix software houses have written emulation packages that can interpret CP/M object code. This capability vastly extends the range of usable applications for Unix. Because Mimix, an emulator for CP/M, is written in C, it is portable and runs on PDP-11, VAX, 8086, and MC68000 Unix systems. The Bridge is another example.

Emulators for MS-DOS, Apple DOS, and CP/M-86 should be available soon.

Business applications: the word processors and spreadsheets mentioned above are the first step toward full business applications. In addition, now that COBOL and BASIC function on Unix, a tremendous body of application software for business can be ported to Unix. The Open Systems and MBSI financial packages already function on Unix, and others are following.

Summary

This powerful operating system is demanding new applications; its software foundation is growing, and Bell Labs' decision to lower royalties and work with equipment manufacturers is giving Unix a needed push. As a result, great numbers of microcomputer users are being attracted by this multiuser operating system, no longer labeled unfriendly since the implementation of front-end menus. The Unix system is catering to the needs of both developers and end users, and a continued increase in widely known business applications will ensure that Unix meets its potential. ■

Mark Krieger earned an M.S. in computer science from Pratt Institute and was a visiting computer scientist at CERN in Geneva, Switzerland. He is president and cofounder of Unipress Software.

Fred Pack earned an M.B.A. from New York University. He is vice-president and cofounder of Unipress Software (1164 Raritan Ave., Highland Park, NJ 08904).

DATA TRANSFER PROBLEMS?

Your Simple Solution is **REFORMATTER**® Diskette Conversion Software



- Avoids serial communication protocols.
- Needs only one system to transfer data.
- Converts source code and data files.
- Allows 2-way transfer.
- Quick, reliable, and inexpensive.

VERSIONS	
Runs On	Reads/Writes
CP/M	↔ IBM 3740
CP/M	↔ DEC RT-11
CP/M-86*	↔ NEW IBM 3740
CROMIX	↔ DEC RT-11
DEC RT-11*	↔ CP/M
MS-DOS*	↔ NEW IBM 3740
TRSDOS II	↔ CP/M
TRSDOS II	↔ DEC RT-11
PRICE:	\$249 *\$350

Requires 8" floppy drive

(415) 324-9114 TWX: 910-370-7457
467 Hamilton Avenue, Suite 2, Palo Alto, Calif. 94301



Even if your business isn't pictured here... **CADO** has the computer system you need.

Whatever you sell—product or service—if you're in business with CADO... you're in business.

It's that simple. CADO has a computer system to help you keep track of every side of your specific business—inside and outside.

Here's why more and more businesses are choosing CADO:

EXPERIENCE. CADO has been installing turnkey solutions to specific business problems for ten years—an era in high-tech time.

SOFTWARE. Hundreds of programs are available through CADO's vast Distributor network. Your nearby CADO office has a staff of professional programmers who can also design or adapt an application tailored to meet your exact needs.

EXPANDABILITY. You can start with a desktop system (video terminal and printer) and grow—with CADO—to a 64-terminal system with 1.1 billion bytes of storage. The fact is, the CADO supermicro outperforms many *mini*-computers that cost tens of thousands of dollars more.

Complementing all that data processing power, you get CADO's exclusive WordBase™ which combines powerful data capture techniques and output control with com-

Circle 75 on inquiry card.

plete word processing capabilities. WordBase does all your word processing, lets you generate custom reports, prepare forms, and create unique data bases—all without hiring a technical staff.

So whatever business you're in—put yourself in this picture. Call **800-556-1234, ext. 128**; in California, **800-441-2345, ext. 128** for the name of your nearby CADO Distributor. Or send in the coupon below.

CADO

A CONTEL COMPANY

CADO Systems Corporation

2055 West 190th Street • P.O. Box 3759 • Torrance, CA 90510
(213) 323-8170 • Telex 66-4711 CADO TRNC

My business is _____

Please rush me more information now about the CADO system I need.

NAME _____

TITLE _____

COMPANY _____

ADDRESS _____ PHONE _____

CITY _____ STATE _____ ZIP _____

BY-9

How HP business graphics



Enhance your reputation for being more professional, persuasive, credible and effective than your competition with the new HP 7475A Business Professional's Plotter.

Make a first impression that lasts

The vital importance of graphics to today's business professional cannot be overstated. In survey after survey, statistics prove graphics can help you spot trends and relationships quickly, analyze data accurately, and communicate your ideas with more

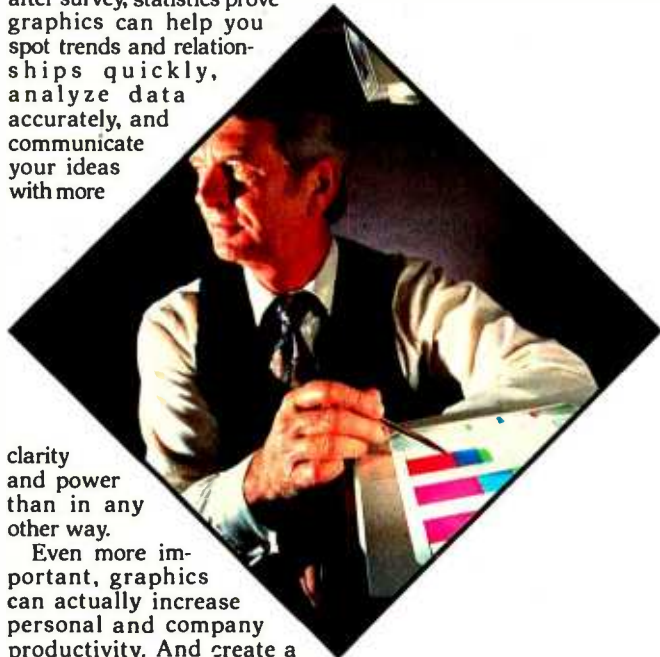

clarity and power than in any other way.

Even more important, graphics can actually increase personal and company productivity. And create a first impression of quality and professionalism that lasts and lasts.

Graphics: the end to meetings that go nowhere

In a fascinating research project conducted by The University of Pennsylvania, 123 MBA candidates were involved in a study designed to test the effectiveness of business graphics in meeting situations. The results were startling. In the group where visual aids were used:

- **Meetings were shorter:** The study showed a 28% reduction in meeting length when transparencies were used.
- **Group consensus was faster:** Agreement was reached by 79% of the group using transparencies, compared with only 8% among the control group using no visual aids.
- **The decision process was accelerated:** 64% of study participants said they made their business decisions *immediately after the visual presentation*. When overheads were not used, the control group said they delayed decision-making until *some time after the group*

discussion following the presentation.

• Presenters with visual aids were perceived as being more professional, persuasive, credible and effective than those not using visual aids.

Now, with the new HP 7475A Business Professional's Plotter, your meetings can have immediate and productive results like these.

How the quality look of HP graphics can help

The way you present your information can be equally as important as the actual information you're presenting. And that's where the new HP 7475A Business Professional's Plotter lets your professionalism shine through.

Standards unsurpassed in the plotter business

The technical standards of the HP 7475A have no equal for producing quality graphics. With a resolution of one-thousandth-of-an-inch, curved lines are smooth, not jagged, and straight lines are *consistently* straight. Its exceptional repeatability (the ability of a pen to return *precisely* to a given point) assures that intersecting lines and circular shapes will meet *exactly*. The result is *high-quality* charts and graphs you'll be proud to present.

Why 6 pens when experts say 4 will do?

Graphics industry experts maintain that good graphics contain four colors per chart. But Hewlett-Packard goes the experts two better by providing a six-pen carousel, so you can store and use pens of different widths—thick pens for bold headings and thin pens for details. And with six pens, you won't have to waste valuable time changing them. That's important when "the boss wants to see your presentation in twenty minutes!"

With the HP 7475A, you also get automatic pen capping to prevent pens from drying out between uses, and special "pen damping" (gently lowering the pen to the paper or transparency) to increase pen life and ensure better line quality... use after use after use. You also get a rainbow of 10 colors to choose from, in two line widths.



Your choice: 2 paper sizes and today's most popular graphics software packages

While most professional business applications will be satisfied with standard 8½ x 11" paper or transparencies, the HP 7475A adds the

can be the key to your success.



capability of plotting on larger 11 x 17" media, too. The larger plots are especially well-suited for time lines, PERT charts, schematics and engineering drawings.

Best of all, you don't have to be a programmer to produce quality graphics on the HP 7475A. It's supported by a variety of professional graphics software packages for both HP and non-HP desktop and personal computers.

Naturally, speaking of software compatibility leads us to hardware compatibility....

Compatible with almost any personal computer in the marketplace today

With two interfaces available, the HP 7475A quickly "makes friends" with most models of today's most popular personal computers, including IBM®, Apple™, Compaq™, Osborne® and Commodore™ -- as well as a host of HP computers.

The cost? Surprisingly affordable

The new HP 7475A Business Professional's Plotter is an amazingly affordable \$1895. When you consider that a typical fee for a single five-color transparency from a graphics service is \$50—and that the same transparency can be prepared for about \$1 in materials on the HP 7475A—the return on your investment is almost immediate.

Another choice: HP's low-cost, high performance Personal Computer Plotter

For the "business on a budget," you may also want a look at our 2-pen Personal Computer Plotter, the 7470A. Its low cost (only \$1095) is as remarkable as the quality of its plots. With many of the same features as the new HP 7475A, the HP 7470A plots on a single paper size (8½ x 11"). It stores and caps two pens,

and you can easily change the pens yourself for multi-color plotting. Best of all, the HP 7470A 2-pen plotter lets you turn your personal computer into a personal graphics workstation for only \$1095.

Send for your FREE "Better Presentations Package" today!

For a FREE sample plot, overhead transparency, and more details, mail the coupon below today. We'll also enclose a list of software packages you can use with the HP 7475A or HP 7470A.

For the name of your nearest Hewlett-Packard dealer call toll-free 800-547-3400.

1101303



YES! I'm ready to gain a reputation for being more professional, persuasive, credible and effective than my competition. Please send me your FREE "Better Presentations Package," so I can learn more about the new HP 7475A Business Professional's Plotter and the HP 7470A Personal Computer Plotter. I understand I will receive this valuable package without cost or obligation.

Name _____ Title _____

Company _____

Address _____

City/State & Zip _____

Phone Number (_____) _____

My computer is _____

Send to: Hewlett-Packard
16399 W. Bernardo Drive, San Diego, CA 92127
Attn: Marketing Communications 11303 BTO

SUMO-TESTED

WOULD YOU BELIEVE 3 OUT OF 4 SUMO WRESTLERS RECOMMEND CASES BY COMPUTER-MATE™?

Neither do we. But, it wouldn't surprise us. Because our cases are built with brute strength, able to take a tough beating from even the mightiest challengers.

Stop wrestling with your computer equipment. With our cases you have ease of transportation plus maximum protection for all your components. Standard cases available for IBM, DEC, Apple, TI, plus many others. Custom built cases are also available to help protect almost any configuration of sensitive equipment.

For loss prevention, each case has a 3" x 5" personal identification frame and individual serial number with toll free number. And like all Computer-Mate products, each case is pre-screened for excellence and backed with a 100% unconditional guarantee.



Chances are your computer equipment will never undergo a heavy bout with a Sumo wrestler, but with protection from Cases by Computer-Mate™, the odds are 3 to 1 your equipment would win.

For order/information contact:

Computer-Mate, Inc.

1006 Hampshire Lane, Richardson, Texas 75080

Dallas (214) 669-9370 • Texas Residents (800) 442-4006

Out of State (800) 527-3643. Dealer inquiries welcome.

Usenet

A Bulletin Board for Unix Users

You can easily connect to a nationwide network of Unix enthusiasts

by **Sandra L. Emerson**

Although they aren't as well known as Unix text editors and program-development tools, Unix communications programs are powerful packages that provide access to Usenet, an electronic network that links Unix users around the country. You need only a Unix system and a modem to electronically send and receive mail, transfer files, and discuss the delights and frustrations of using Bell Laboratories' operating system. The comprehensive set of networking capabilities even enables you to log in to both a local and a remote system and work on the two simultaneously.

The Usenet Network

Usenet provides a set of programs (collectively called netnews) that allows messages to be posted in news groups, where user-defined topics are discussed. Anyone who has access to a Unix system running Usenet can participate in this network: there are no special membership requirements. The network is managed and maintained cooperatively by volunteers. Although no central administration exists, individual members who devote a significant amount of time to Usenet are generally considered opinion leaders when policy or strategy decisions are needed. Mark Horton, who works at a Bell Laboratories branch in Columbus, Ohio, is such a leader. Horton, who became

interested in Usenet while at the University of California at Berkeley, helped develop the current Usenet programs. He points out that Usenet has grown from 50 sites two years ago to more than 500 today, with 5 to 10 new sites joining every month. In January of this year, Horton polled Usenet members to assess their feelings about a potential surge in membership resulting from the spread of desktop Unix systems now available at more popular prices. Although some members were concerned that the network might become overloaded, the general sentiment was in favor of continuing to allow anyone with access to a Unix system to join.

Participation in Usenet

To set up a Usenet site, you need a Unix system, a modem (preferably an auto-dial type), and disk storage to cope with the flood of messages that Usenet will unload once you are connected. It's not unusual for a large Usenet site to have more than 2 megabytes of messages in its queue.

The C-language Usenet programs run under the Unix operating system, but physical networks other than Unix's native uucp (Unix-to-Unix copy) can be used to carry the news: for example, gateways exist on a limited basis to the Defense Department's ARPANET and IBM's Bitnet. The majority of sites, however, use

the uucp programs because they are already supplied with the rest of the Unix software and their use requires no special hardware.

Usenet members can sign up for any of several dozen news groups on topics ranging from assembly language to auto mechanics. And any user can start a news group. The Usenet community—currently made up of Unix users at universities, manufacturers and packagers of Unix systems, and providers of Unix-related services—has already built a large, unique, and occasionally rich database of news and commentary.

Usenet's History

The Usenet software was developed by a group of programmers—Steve Daniel, Tom Truscott, Steve Bellovin, and James Ellis—at Duke University in the spring of 1980. The first connection they made was to the neighboring University of North Carolina. Prior to the development of Usenet, Unix users could send electronic mail and files from point to point using the existing Unix network facilities, but no larger organizational framework or technical support was available for pooling news from a wide reading audience.

Version A of the Usenet front-end software was originally intended for use by the members of Usenix (university Unix users group) as a means

for online publication of their newsletter, but this implementation never really materialized. In the fall of 1980, Mark Horton at Berkeley learned of Usenet and became the first West Coast link. After the network was introduced at a Usenix meeting in Delaware, several more Unix sites were connected to it. Soon Usenet sites were scattered across the country; Oregon's Reed College and the University of Oklahoma were early members. Shortly afterward, programmers at Bell Labs (at the mother node in Holmdel, New Jersey) took notice, and Usenet was strengthened by the addition of Bell Labs personnel and facilities. With very little advertising, Usenet gained 50 member sites in its first year.

The Usenet software was originally designed to deal with a volume of one or two news articles per week. With an increasing volume of messages (the current level of activity is nearly 50 new articles per day), it became clear that new front-end software was needed. Aided by a talented young programmer named Matt Glickman, then a high school sophomore, Mark Horton and others at Berkeley rewrote the Usenet software early in 1982. The version B programs could handle the increased volume and, more important, could sort the messages by topic. Previously, messages for all news groups had been delivered in the order in which they arrived at the news machine. The version B programs (B News) contributed significantly to the growth of the network. The latest release of these programs is B News 2.10 (spring of 1983). The older form of the news programs, A News, is still in use at two of the original Usenet sites. A screen-editing front-end package called *notesfiles* is also available at some Usenet sites.

Between releases of front-end software, any Usenet member may suggest improvements or solutions for bugs and post them in a news group. They are then distributed to the network from news groups such as *net.sources*.

When a new member joins Usenet, a neighboring site sends a copy of the source for the news programs and

documentation to the new site. Installing the programs and custom-tailoring them to individual needs is not particularly complicated; adequate disk storage, however, is quite important because the programs and documents themselves now consume about 700,000 bytes. Because of its size, the 2.10 B News release is being distributed in Unix tar format (suitable for tape or disk) instead of through the *net.sources* news group.

Finding your nearest local site is a key part of getting on Usenet, either as a new site or as a user. Because there is no central distribution point for the Usenet programs, the spread of both news and software depends on the cooperation of member sites in forwarding materials to their part of the network.

It's a Bulletin Board

Although the protocols of getting on Usenet and adding or reading messages are slightly more elaborate than those for The Source or CompuServe, Usenet does appear to the user as would most electronic bulletin boards. Messages are dated and posted in news groups, each of which is named according to the main subject matter of the messages it posts. Anyone entering a message must decide which news groups should receive it. Messages and announcements of general interest are posted to *net.general*. For example, *net.general* might announce the formation of new news groups, post trivia questions, and relate other miscellaneous messages.

As in many information utilities, each subscriber can select a personal list of topics. However, users may read articles from any news group at any time. The software can keep track of which articles have been read; unread articles are listed chronologically by publication date, beginning with the earliest.

Of the more than 500 official Usenet sites, most are at universities and Bell Labs research facilities. Each site that has an intelligent modem (and can therefore forward messages) agrees, by convention, to forward news to at least two or three other machines. This agreement cuts down

on phone costs and helps distribute network maintenance. However, each region also has one or more backbone network machines that link to up to 50 Unix systems. Recently, manufacturers of Unix systems and software and providers of Unix-related services have been joining Usenet in increasing numbers. The user population might therefore be shifting from an academic and research community to one including many representatives from the outside world. The Usenet reading audience undoubtedly numbers in the thousands.

A Map of the Network

Of course, you don't have to be an official site in order to participate in Usenet. Many Usenet users simply obtain accounts on major network node machines, such as the nearest VAX, and dial into these machines to read the news. Users at official Usenet sites who have agreed to store and forward news set up *uucp* links with the network node machine and with their neighboring Usenet machines. The *uucp* programs function by queueing up work in a spooling directory and performing it at times specified in system files. The fact that the *uucp* process always involves copying—copying out work to be sent and copying in work to be received—is another reason that adequate disk storage is important for Usenet sites. Usenet sites poll the network on a regular basis, telephoning specific machines at agreed-upon times to send and receive work.

If you own a desktop Unix system, to join Usenet you will likely become an end node connected as a satellite to the nearest large Unix system. Particularly in the San Francisco Bay area, some manufacturers of Unix systems and software have been making their in-house development machines available on a limited basis for Usenet use.

Although no formal mechanism for network self-study is set up, interested users periodically measure the volume of traffic, make a map of the network, and even analyze the content of network news and post it to the appropriate news groups. Several

TCS Heart of TEXAS COMPUTER SYSTEMS

Toll Free 1-800-433-5184

Texas 1-817-274-5625

CORVUS

HARD DISK DRIVES Complete from \$1649

Single and multiuser HARD DRIVES for all brands of computers
One or several computers can share A HARD DISK.

Tandon

TCS DRIVE CABINET is industrial grade heavy guage metal, safety fused, and comes with gold plated external connector with extender cable.

1 DRIVE in Cabinet

40 track single sided \$199
80 track (dual sided 40 track) \$299
160 track (dual sided 80 track) \$399

2 DRIVE Double Cabinet

40 track single sided \$399
80 track (dual sided 40 tracks) \$599
160 track (dual sided 80 tracks) \$799

1 DRIVE Double Cabinet

40 track single sided \$259
80 track (dual sided 40 track) \$349
160 track (dual sided 80 track) \$449

Drives in cabinets come assembled and tested with power supply. Order cable separately.

BARE DRIVES ONLY

40 track single sided \$165
80 track (dual sided 40 track) SCALL
160 track (dual sided 80 track) SCALL
8 inch Slimline sgl/dbl sided SCALL
Winchester Hard Drives 5 Meg. \$399

CALL IF YOU FIND A LOWER PRICE ON DRIVES

PERCOM

Hard Drives supporting both DOSPLUS and LDOS

5 Megabytes of storage \$1390
10 Megabytes of storage \$1690
15 Megabytes of storage \$1990
20 Megabytes of storage \$2490

PRINTERS



PRINTER CABLES AND INTERFACES AVAILABLE
Call for current pricing

PRINTERS

- * 100 - 120 - 160 CPS
- * Bidirectional Logic Seeking
- * Friction and Tractor
- * 9X9 Dot Matrix
- * True Decenders
- * High Res-Bit Image Block Graphics
- * Super Script-Subscript
- * Underlining
- * Backspacing Doublestrike
- * 5, 6, 8 1/2, 10, 12 and 17 Pitch
- * Programmable Line Spacing
- * SIX (6) MONTH WARRANTY

GEMINI 10X (9 Inch Carriage, 120cps) Friction and Tractor \$CALL
GEMINI 15 (15 Inch Carriage, 100cps) Friction and Tractor \$CALL
GEMINI 15X (15 Inch Carriage, 120cps) Friction and Tractor \$CALL
DELTA 10 (10 Inch Carriage, 160cps) Friction and Tractor \$CALL

STAR Printers can be interfaced with most computers on the market today, such as: Apple II, III, IBM PC / Osborne / Heath Kit H89 / TRS-80 Model I, II, III, 4, 12, 16, 100 Zenith Z89, Z90, Z100 / T199/4A / Kaypro / Atari 400, 800 / Commodore 64, VIC 20

CALL FOR OUR LOW PRICES

Smith-Corona® TP-1

LOW COST LETTER QUALITY DAISY WHEEL PRINTER

Your choice PARALLEL or SERIAL Interface

List Price \$895.....~~\$479~~.....\$CALL

TCS has the LOWEST PRICES on IN-STOCK PRINTERS!

DOT MATRIX PRINTERS

EPSON RX/FX
C ITOH 8510/TEC/PMC
DMP 100
DMP 200
DMP 400
DMP 500
DMP 2100
ANADIX 9501-A
CENTRONICS 352/353
OKIDATA

LETTER QUALITY PRINTERS

SILVER REED/BMC (16cps)
BROTHER/COMREX/BMC (16cps)
DMP 2100 (160/wp/100cps)
RS DAISYWHEEL II (40cps)
DWP 410 (25cps)
C ITOH F-10 (40 CPS)
NEC 3520/3530/3550
NEC 7710/7730

IBM

320K Bytes Tandon Disk Drives \$CALL
QUADBOARD 64k - 256k memory, clock, serial, parallel \$279
BMC RGB Ultra Hi Res Color Monitor \$449
HARD DISKS from \$1390

TRS-80

TRS-80 equipment comes with original 90 day Manufacturer's Limited Warranty.

MODEL 12 and MODEL 16

MODEL 12, 1 drive \$CALL
MODEL 12, 2 drives \$CALL
TCS MODEL 12 version, 2 Tandon drives (like the original) \$2995

MODEL 16B...Support up to 6 users. Run your whole office with hard disk capabilities for about \$1000 per user!

MODEL 16B, 1 drive \$CALL
MODEL 16B, 2 drives \$CALL

Model 12 and Model 16 Accessories

128K memory board (256K Max.) \$629
128K extra memory chips (RS) \$269
128K extra memory chips (TCS) \$189
Kenix Microsoft Multi-user Basic \$269
Kenix Accounting Software \$CALL
Kenix Multiplan Spread Sheet Software \$263
MII/12 to M16 multi-user upgrade kit \$1339
DT/1 Video Terminal \$629

MODEL IV

MODEL IV, 16K Cassette \$825
MODEL IV, 64K, 2 drives, RS-232 \$CALL

Model III Color Computer

All Radio Shack equipment is shipped from our store in Brady, Texas

TCS Model IV, 64K, 2 Disks

Systems come with 180 Day Warranty

\$1499

With standard 40 track double density drives. Over 340,000 bytes.

Enhanced Model IV Operating System

RS-232 FREE!

\$1699

With 2 dual headed 40 track double density drives. Over 730,000 bytes.

Enhanced Model IV Operating System

Fully assembled and tested systems that are software compatible and functionally identical to Radio Shack units sold at computer stores for \$hundreds more.

- * CONTROLLER BOARDS are high quality double sided epoxy boards with gold plated contacts.
- * POWER SUPPLY is the finest switching type available.
- * MOUNTING HARDWARE includes power and data cables.
- * DISK DRIVES are Tandon, the same ones used by Radio Shack. 40 track, double density, with a 5 millisecond stepping rate.

TCS MODEL III DISK EXPANSION KITS

1 Controller, Power Supply, Mounting Hardware & Instructions \$249
2 Controller, Power Supply, Hardware & one 40 track Tandon Drive \$429
3 Controller, Power Supply, Hardware, two 40 track Tandon Drives \$598
3a Kit 3 but with two 80 track drives (dual sided 40s) \$791
3b Kit three but with two 160 track drives (dual sided 80s) \$989

TCS MODEL IV DISK EXPANSION KITS

11 Controller, Power Supply, Mounting Hardware, one 40 Track Tandon Drive \$479
12 Controller, Power Supply, Mounting Hardware, two 40 Track Tandon Drives \$649
12A Kit 12 but with two 80 Track Tandon Drives \$629
12B Kit 12 but with two 160 Track Tandon Drives \$849

DAVONG HARD DRIVES

5 Megabytes of storage from \$1295
10 Megabytes of storage \$CALL
15 Megabytes of storage \$CALL
Networking systems for multiuser hard disks. Tape and cartridge back up systems are also available for IBM PC, APPLE II, and APPLE III.

APPLE DISK DRIVES

High quality slimline drives
1st drive w/controller \$279
2nd drive only \$229
Totally compatible with all apple software

\$CALL

TCS Heart of TEXAS COMPUTER SYSTEMS

P.O. Box 1327 Arlington, Texas 76004-1327

Toll Free 1-800-433-5184 Texas 1-817-274-5625

Circle 467 on inquiry card.

S-100

ESTABLISHED 1977

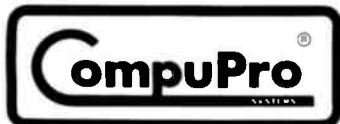

SYSTEMS CENTER

System 8/16A	\$4495
System 8/16B	\$5395
System 8/16C	\$6895
System 8/16 68K	\$6895
MULTI-PRO™ MP-10	CALL
System Z80	\$2895
20 MEG. HARD DISK SUB-SYSTEM For ALL SYSTEMS	\$2899

★ Fully Assembled & Burned-in ★

All Systems include SORCIMS SUPERWRITER SPELL CHECKER, MAIL LIST & FORM LETTER PROGRAMS

INTERFACER 3-B Serial A&T	\$515
RAM-1B 64K 8/16 A&T	\$415
RAM-21 128K 8/16 A&T	\$825
RAM-22 256K 8/16 A&T	\$1395
CPU 88K W/CP/M & 4th A&T	\$790
8IX SLOT MOTHER BOARD	\$99

MORROW

MO2 W/LIBERTY FREEDOM 100 TERMINAL & TALLEY SPRINT PRINTER	\$1,595
MO3 WALL OF THE ABOVE PLUS QUEST BOOKKEEPING	\$1,895
16MEG. WINCHESTER DRIVE SUBSYSTEM W/S/W FOR THE MICRODECISION	\$2,195
MULTI-VO W/3 SERIAL 1 PARA. RT. CLOCK & INT.	\$300
8" SUBSYSTEM W/OS DD DRV. QJDMA, CP/M & BASIC	\$1,095

COLUMBIA

MODEL 1600-1 W/S/W KB. CRT CONT. ZENITH HI-RES RGB & GRN MON	\$3,270
--	---------

EAGLE P.C.-2

\$2995

Access

CALL

COMPLETE PORTABLE W/64K RAM, 7" AMBER, 2 DRV., 2 MODEMS, MX80 PRNTR, Sep KB, GRAPHICS W/Lots of S.W. & Tutorials, USI 12" AMBER MON & Many Options Avail.

PRINTERS

DAISYWRITER	CALL
TALLEY MT 160L	CALL
EPSON MICROBUFFER 8K Serial For Epson	\$129
OKIDATA	CALL

Votrax

Personal Speech System

\$285

SMS THE LAST MEMORY™

W/O RAM \$140

W/64K HI-SPD STATIC RAM \$269
OR MIX EPROM & RAM-WILL WORK WELL IN NORTH STAR HORIZON



Z 80 CPU \$239
W/SERIAL PORT

SEATTLE COMPUTER

GAZELLE-III-USER SYSTEM W/XENIX 82 MB HD. (TAPE BACK-UP OPTIONAL)	\$1,198
64K RAM BDW/85 NS CHIPS	\$ 476
8087 CPU UPGRADE	\$ 316
DISK MASTER 5 1/4 & 8 in	\$ 340



COMMUNICATIONS

MM-212 1200BAUD	\$625
S/100 MODEM BD. W/S.W. & LOTS OF EXTRA FEATURES	

NOVATION

J-CAT MODEM	\$119
FOR ALL MICROS INCLDS. ALL CBLs.	



VB 1C MEMORY MAPPED VIDEO BOARD	\$206
---------------------------------	-------

TRANSMODEM 1200 BY RACAL VADIC	\$475
EASIER TO USE THAN MOST OTHER MODEMS ON THE MARKET	

PC MATE by TECMAR FOR IBM

1st MATE 64K Plus SERIAL	\$295
2nd MATE 2 SERIAL/2 PARA	\$229
5 MEG. CART WINCHESTER	\$1,495
Lab Quality D/A & A/D BOS for IBM-PC & S-100 BUS	

S-100 MAINFRAMES

PARA DYNAMICS

3820S PRONTO W/SEQUENCER HEAVY DUTY PWR. & COOLING FOR 20 BOARDS AND ANY MIX OF DRIVES & BACK-UP DEVICES	\$1,235
3020 R RACK MOUNT 20 SLOT	\$715
2200 R RACK DUAL 2" DRV. CAB.	\$525
3510 D 10 SLOT. DUAL 5 1/4"	\$685

INTEGRAND

800 082F W/OPTIONS	\$497
SPEC. PAINT, FILTERS, S-100 CONNECTORS, AC CBLs, TERM. M.B.	
1100 0 W/WOOD TRIM	\$449

FLOPPY DISK DRIVES

ADD-ON DRIVE SYSTEM ALL-IN-ONE CABINET WITH 20 MEG. H.D. & 2 GUME 242 F.D. CABINET, PWR. SUP., CABLES, & FAN W/FILTER INCLD.	\$3,595
--	---------

Qume 842 8" DSDD	\$460
242 8" DSDD	\$445
142 5" DSDD	\$190

IBM has recently selected the GUME Drive for their PC.

Tandon 100-2 5 1/4 in. DSDD	\$229
-----------------------------	-------

different network maps have been produced according to various schemes. A list of longitude and latitude points of Usenet sites has also been published, but users comment that when lines are drawn to indicate links, the resulting map is quite confusing. Many cross-country links exist, and a geographical map of the network is therefore both hard to read and not particularly useful. Every few months, users such as Bill and Karen Shannon and Karen Summers Horton produce logical maps of the network. The Shannons' Usenet Logical Map (figure 1) is designed to be legible even in output from dot-matrix printers and will fit on one notebook page when reduced. As figure 1 shows, Usenet is a lumpy network, and, predictably, some of the largest nodes are supported by machines at Bell Labs. In recent months, the map has spawned an outtrigger of West Coast Unix system manufacturers in its upper left quadrant, as witnessed by names such as Varian, Zehntel, Fortune, Altos 86, Sun, and Onyx.

Current News Groups

Presently more than 100 news groups are in Usenet, including several groups whose messages are piped to Usenet from ARPANET. News groups with the prefix "fa" come from ARPANET: those prefixed with "net" are of network-wide distribution, and news groups with no prefix are local ones.

What do Usenet users talk about? As might be expected, this community of Unix users devotes most of its energy, by volume of news, to discussing Unix itself. Because the Unix programs and utilities were developed over more than 10 years in relatively sheltered environments such as Berkeley and Bell Labs, such discussions could go on for years. Not only are there hundreds of utility programs in the standard Bell Labs Unix distributions, but dozens more are under development. Moreover, systems such as Whitesmith's Idris constantly sound variations on the Unix theme. Now that Unix is available commercially, dozens of applications programs are being developed, each

14425 North 79th Street
Scottsdale, Arizona 85260
TELEX: 16 5025 FTCC SEC PHX
SALES
800-528-3138
TECHNICAL 602-991-7870
Circle 407 on Inquiry card.

FULL DEALER SUPPORT
VISIT OUR SHOWROOM
Hrs. 9:00AM - 5:30PM M-F
Subject to Available Quantities
Prices Quoted Include
Cash Discounts
Shipping & Insurance Extra

Announcing

SuperSprite™

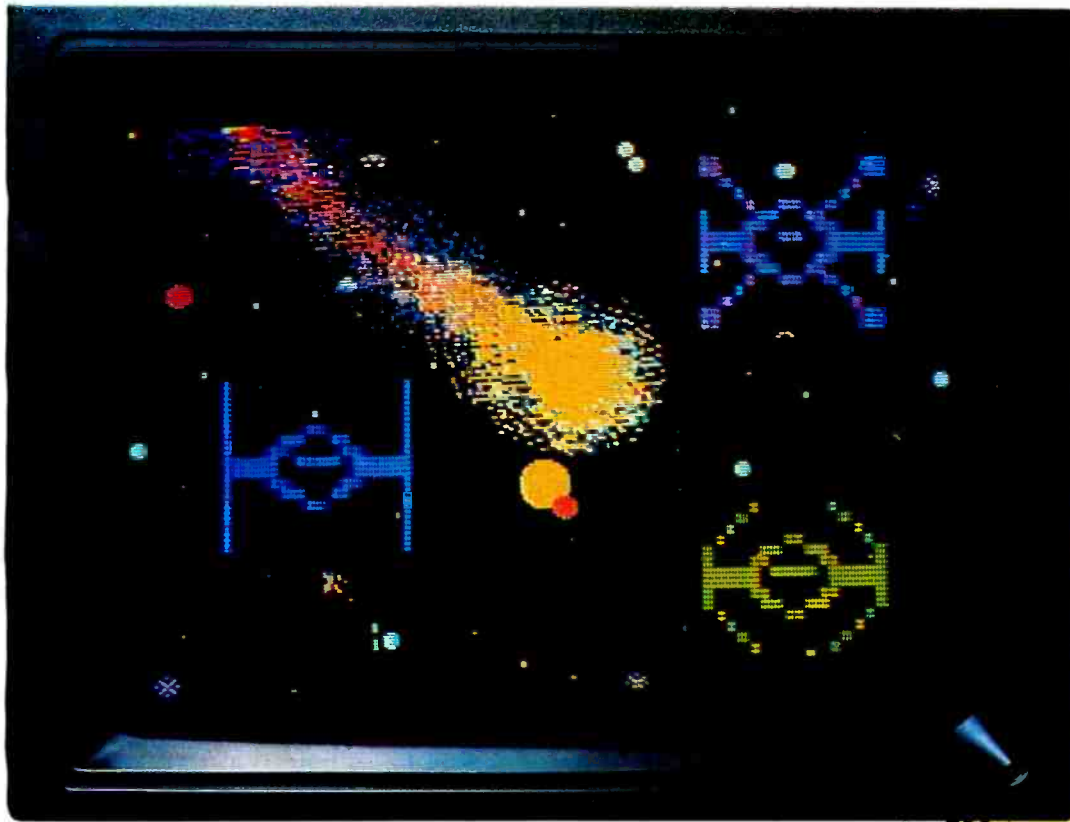

Plug arcade excitement into your Apple computer

Super Sprite is an amazing peripheral card that plugs easily into the Apple's expansion slot. It magically transforms your Apple into an exciting entertainment center for colorful and dramatic animation, realistic sound effects and actual speech.

Sprites Galore

Only Super Sprite has multi-plane graphics for life-like 3-D animation. Watch your screen come alive with animated characters (sprites) that flit and fly, intersect and interact, and never get in the way of each other. And sprite action can join standard Apple graphics on the screen at the same time.

Software Support

Every Super Sprite package includes the Ampersprite™ software language that lets you devise sprites in seconds from the keyboard. Plus sound effects and speech! Or, simpler yet, you can buy a commercial game that's already written around the Super Sprite.

Your computer store should have Super Sprite in stock. If not, ask him to order one for you. Suggested retail is only \$395.



Super Sprite package includes operator's manual, Ampersprite programming utility and demo diskettes.



Synetix Inc.

15050 N.E. 95th, Redmond, WA 98052. (206) 881-7110 1-800-426-7412

* Ampersprite is a registered trademark of Avant-Garde Creations, Inc. ** Super Sprite is a registered trademark of Synetix Systems, Inc., 1983. © Copyright Synetix Systems, Inc., 1983

*Apple is a registered trademark of APPLE COMPUTER, INC.

Circle 454 on inquiry card.

BYTE October 1983 223



```

alberta--ubc-vision--sfucmpt   wjhl2--foxvax1   utcsstat--utcsrgv--trigraph
ubc-medgen | mpvaxa grkermit--genrad--mitccc wateng--watdaisy | dciem
teltone--uw-beaver--uw-june--uw70   linus--security   watmath---+=utzoo==+
microsoft--fluke--vax1   uw-vlsi   wivax   vaxine   watarts   watcgl   hcr
| ssc-vax   vax2   vortex   unh   | medmap--cwruecmp--cwrunix
=====+=====+=====+decvax=+=====+=====+=====+
ittapp | ndcuts   tpdcvax   twin40--web40   mi-cec--idis--pitt--dri0 | adiron
+=====ittvax=====+-----bunker   ikonas-----+mcnc=+-----+-----duke=====+-----phs
qumix   sii   dcdwest   wxlvax   | uvacs--ncsu   tucc--unc+   ucf-cs--uf-che
trwspf   trwssp +=====sdcsvax=====+-----sdchema   msdc   ecs   brl-bmd   fau
trw-unix--+   | sdcsla   philabs--+   | emory   udrelay   unm-ivax--nmtvax
sdcrcdf--sdccsu3   phonlab   micomvax   | cmcl1   nyccb   rocky2   lanl-a   cubs45
bmcg   sdcattb--sdCatta   noscvax   | +=====cmcl2=====+-----+-----esquire-----+
| sdcarl   | tpsa--spanky   | e   f   g   j   (hocs*)   | sbcs
| 594lux--machaid--hocda   | d--+=hocsb=====+-----k   | peri
==houxm=====+ (houx*)   q   r   y   +=houxz=====+-----hou5d--hou5a   +=floyd=====+
---b---+=houxa+=+-----+houxi==+-----p   ihps3   | hou5e   vax135
-h--j--k   c   f   o   hound   uofm-cv   | npoiv   hou5c   | cornell
| bpa--sb6   scbhq   +-----mb2b--uofm-hfh   | hou5f--hou5b   | uw-beaver
att3--111--+=sbl=====+-----burl--kcwin--we53   | houxe   orion--ariel
+=====otuxa=====+-----+-----wel3=====+-----+-----lime+-----+-----houti--houca
we04-3b   nwuxc   inuxa   inuxb   inuxd   uniq   | hoh-2   houxc   deimos
princeton   +=====+inuxc=====+-----ixn5c--druxs--drux[h-r,t-z]
-----pur-ee--iuvax--isrnix   | iwlc8   iws11
minn-ua   | ecn-pa--ecn-pb--ecn-ed   | iwlc7--iws13--iws12
umn-cs   purdue-----+-----pucc-h--pur-phy   | ihps2-----iws14--iwlc6
stolaf   ncrday--cincy   pucc-i   ihhf1   | | iws15   iws16
ihps3   | ihns   ixn5h   iheds   ihn5i   | | ihuxk--ihlap
+++++=====+=====+=====+=====+=====+=====+=====+=====+=====+=====+
| ihpad   | ix1pb   | ixn5e   | ihtpa   | ihux[a-j,l-u,w,x]
ixn5d   ihima   ixn5c   cdlnccch--laidbak--trsvax
=====harpo=====+=====+=====+=====+=====+=====+=====+=====+=====+=====+

```

* European map *

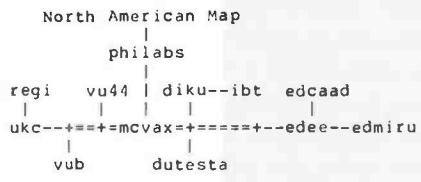
EUROPE



of this writing, six out of the 100 active groups are discussing specific technical aspects of Unix. Another 16 news groups are concerned with other aspects of the computer industry. For example, six groups are

discussing microcomputers, one group has an interest in peripherals, and another is addressing data communications. In short, the Usenet online conference is somewhat like a real-time



- ANADIX**
- Epson**
- DATASOUTH**
- NEC**
- Daisywriter**
- Diablo**
- Ribbons**
- Gemini**
- MANNESMANN TALLY**
- Okidata**
- MPI**
- PRICES SO LOW— WE CAN'T LIST THEM!**
- ADDs**
- Smith Corona**
- QANTEX**
- SUPPLIES**
- LEAR SIEGLER**
- AMPEX**
- ESPRIT**

All equipment is in factory cartons with manufacturers' warranty. Prices subject to change without notice. Most items in stock or shipped as received.

1 **NATIONWIDE SERVICE. MOST PRODUCTS**
SUPER WAREHOUSE

P.O. BOX 373 WALLINGFORD, CONNECTICUT 06492
ORDER LINE **ORDER HOURS**
203-265-1223 **9:00 AM - 5:00 PM-EST**
MONDAY-FRIDAY

PHONE ORDERS FREE
(ONE DOLLAR CREDIT FOR PHONE ORDERS)

Announcing the Encore™ diskette.

The way it performs, you'd never guess it costs only \$1.59*.

Here's your best value in diskettes today.

New Encore meets the same high standards that big-name brands meet—100% error-free performance, ANSI certification. In many cases it actually exceeds system requirements. There's even a 1-year replacement guarantee.

Yet the cost is as low as \$1.59 for single-sided, single-density 5¼" Encore diskettes (when you purchase four or more boxes, ten diskettes per box).

And only \$2.99 for double-sided, double-density 5¼" Encore diskettes.

With important savings comes reliable performance on all popular systems: Apple II, IIPlus, IIe, III; IBM PC; Radio Shack TRS-80; DEC; Wangwriter and many others. So from now on, get accurate, reliable performance without the high cost. Get Encore.

**Send coupon today. Or call
1 (800) 547-5444.
In California 1 (800) 547-5447.**

To ensure your complete satisfaction, Encore diskettes are covered by a 45-day risk-free trial period. Allow two weeks for delivery. This offer good only in the Continental U.S. Call for information on system compatibility.

FREE Inmac Floppy Library Case!

Order your Encore diskettes within the next 30 days, and with each box you'll receive a free Floppy Library Case for easy storage, fast retrieval, and sure protection of your data. But hurry—supplies are limited. (Limit 4 per order)

inmac™

World's leading source of computer supplies and accessories.



*Price for one SSSD 5¼" Encore diskette when purchasing 40 or more diskettes.

ORDER NOW

Inmac, Encore Introductory Offer, 2465 Augustine Dr., Santa Clara, CA 95051. Yes, I think Encore sounds like a great deal. Please send me:

No. of boxes	Order No./Description	Price per box of 10 diskettes		
		1	2-3	4+
_____	7970 - 5¼" SSSD soft sector	\$25.90 (2.59 ea)	\$19.90 (1.99 ea)	\$15.90 (1.59 ea)
_____	7971 - 5¼" DSDD soft sector	\$43.90 (4.39 ea)	\$35.90 (3.59 ea)	\$29.90 (2.99 ea)
_____	7960 - 8" SSDD soft sector	\$39.90 (3.99 ea)	\$29.90 (2.99 ea)	\$26.90 (2.69 ea)
_____	7961 - 8" SSSD soft sector	\$32.90 (3.29 ea)	\$24.90 (2.49 ea)	\$19.90 (1.99 ea)
	IBM format 2305830			
		Subtotal	_____	
		Sales Tax*	_____	
		Total Order	_____	

*Customers in CA, CO, DC, NJ, NY, TX, IL, GA add applicable tax.

Check enclosed Bill Company P.O. No. _____
 Visa MasterCard Account No. _____

Signature _____
Name _____ Phone _____
Firm _____
Address _____
City _____ State _____ Zip _____
 Please send me a free Inmac catalog. 107130

control	net.games.emp	net.micro.pc	net.sf-lovers
fa.arms-d	net.games.rogue	net.misc	net.singles
fa.editor-p	net.games.trivia	net.movies	net.social
fa.info-terms	net.garden	net.music	net.sources
fa.info-vax	net.general	net.new.group	net.space
fa.info-visi	net.graphics	net.news	net.sport
junk	net.ham-radio	net.news.config	net.sport.baseball
msgs	net.invest	new.news.groups	net.startrek
net.ai	net.jobs	net.news.map	net.suicide
net.audio	net.joke	net.news.newsite	net.taxes
net.auto	net.jokes	net.nlang	net.test
net.aviation	net.jokes.d	net.notes	net.travel
net.books	net.lan	net.periphs	net.tv
net.bugs.2bsd	net.lang	net.pets	net.unix-wizards
net.bugs.4bsd	net.lang.c	net.philosophy	net.usoft.s
net.bugs.uucp	net.lang.pasca	net.physics	net.wanted
net.college	net.lang.pascal	net.poems	net.wine
net.columbia	net.mail	net.politics	net.wines
net.comics	net.math	net.railroad	net.wobegon
net.cooks	net.med	net.rec	net.women
net.cycle	net.micro	net.rec.caves	net.works
net.dcom	net.micro.68k	net.rec.photo	parents
net.emacs	net.micro.apple	net.records	
net.flame	net.micro.atari	net.religion	
net.followup	net.micro.cpm	net.rumor	

Table 1: A list of active news groups compiled from a San Francisco Bay area news machine in May 1983. The net.cooks, net.unix-wizards, and net.sf-lovers were among the list's most active groups; each contained more than 500 current articles.

conference composed mostly of academic, technically sophisticated computerists: their favorite play is their work. However, at least a third of the news groups are concerned with hobbies and recreation. Computer games—mostly of the Dungeons and Dragons genre—are well represented. There have also been groups on birds, boats, bridges, caves, coins, photography, and scuba diving. The news groups on science fiction (net.sf-lovers) and the *Star Wars* movies have attracted so much activity that some members have grumbled publicly about these "groupies" and the amount of disk space they consume. Because messages stay on the network for two weeks unless an earlier expiration date is specified, a very active news group can indeed loom large on the network terrain. (For a partial listing of Usenet news groups, see table 1.)

Usenet Site Requirements

The most important prerequisite for becoming a Usenet site is to know the location of the nearest existing Usenet site and the name and telephone number of the person in charge of it. You must have access to a Unix system and have system-man-

ager (superuser) privileges in order to set up the uucp and netnews system files. You also need a modem, preferably an auto-dial one (to initiate transactions), and sufficient disk storage to handle the news flow.

With an auto-dial modem, your system can telephone other systems and initiate uucp work, including Usenet work. Such systems are called active uucp sites. When an active system initiates a uucp transaction, it telephones the remote system and allows that system to log in as a user. The active system then performs work for the remote system. Without an auto-dial modem, you must wait until a neighboring active site telephones your system, then your work is passed along to the active site only after it has emptied its queue of work being sent to your system. Although being a passive site is not a great limitation, you must arrange for an active site to poll your system on a regular basis. You can do so by exchanging tokens such as system names and setting up system files that contain phone numbers and calling times. Although an active site can poll 7 to 10 machines for work, the uucp link connects only two machines at any time.



13 TIMES FASTER THAN dBASE II™

If you bought your computer to save time, then you need SUPER, the most powerful database system you can use. Power is a combination of speed, ease of use and versatility. SUPER has them all.

FAST - To demonstrate SUPER's speed, ISA retained a professional dBASE programmer to benchmark SUPER vs. the acknowledged leader. A simple mailing list application was chosen to minimize dBASE programming cost. The results:

Task	SUPER Time	dBASE II Time
Set up/Program	5:20 min.	12:18:00 hrs.
Input 100 records	50:29 min.	1:27:50 hrs.
Sort & Print Labels	6:41 min.	4:18 min.
Totals	1:02:30 hrs.	13:50:08 hrs.

Notice that SUPER was faster at every task where *your time* is involved—and saving your time is probably the whole reason you bought a computer.

EASY TO USE - SUPER won because of its ease of use. Since it is menu-driven, office personnel can easily learn to use SUPER to set up their own applications, speeding and simplifying dozens of tasks without the need of programmer support.

VERSATILE - SUPER, unlike other business programs, doesn't dictate how to run your business. With SUPER the computer does what you want, when you want, the way you want it. *SUPER may be the only business program you'll ever need.* It can handle customer files, payables, receivables, depreciation, appointments, cost accounting, time charges, commissions, inventory, manufacturing control, and even matrix accounting systems!

SUPER PERFORMANCE AT A SUPER PRICE -

That SUPER beats the \$700 dBASE program may surprise you, but in terms of price vs. performance SUPER has no competitors. Among its features are: production input, data compression, multiple databases on line, transaction posting, file reformatting, stored arithmetic files, flexible report formats, hierarchical sort and multi-disk files for up to 131, 068 records. It can select by ranges, sub-strings, and field comparisons. It interfaces to word processors such as WordStar™, SuperSCRIPTSIT™, Model II/16 SCRIPTSIT™, and NEWSRIPT™. In fact SUPER has so many features that

it takes a six-page product description to cover them all. Write or call and we'll send you one.

SUPER is available for TRS-80™ Models I & III under NEWDOS™, LDOS™, and DOSPLUS; for TRS-80 Models II, III and 16 under TRSDOS™; and CP/M™ systems.

NOW \$199.00*

Manual (Price applicable to purchase) \$ 25.00

Now available for the IBM PC

MasterCard and VISA accepted.

OTHER SOFTWARE

- **ManageMint™:** A PERT/CPM project management system compatible with SUPER. It includes scheduling, resource and financial management modules.
- **Sales Planning and Data Extraction System:** Improves hit rates while cutting costs.
- **Small, economical program packages** for accounting, business and office applications as well as utilities.

Write for Catalogue



Institute For Scientific Analysis, Inc.

SOFTWARE FOR HARD USE™

Dept 84 Institute for Scientific Analysis, Inc.
P.O. Box 7186 Wilmington, DE 19803 (215) 358-3735

ORDERS ONLY
800-441-7680 EXT. 501

Trade mark owners: dBASEII-Ashton-Tate. SCRIPTSIT, SuperSCRIPTSIT, TRSDOS, and TRS-80-Tandy Corp. NEWDOS/80-Apparat. Inc. WordStar-MicroPro Intl. Corp. NEWSRIPT-PROSOFT. LDOS-Logical Systems, Inc. CP/M-Digital Research.

*Plus \$15.00 formatting charge for non-standard CP/M version.

"I built this 16-bit computer and saved money. Learned a lot, too!"

Save now. Build the H-100 kit, a computer that will keep pace with technology for years to come.

Advanced 16-bit computing at a kit price! With most circuit boards already pre-wired, H-100 is our easiest computer kit. And our manuals ensure that "We won't let you fail!"

Dual microprocessors deliver 16-bit speed and 8-bit compatibility. The industry standard S-100 card slots allow a host of peripherals and memory expansion to 768K RAM.

A high-density (320K) 5.25" drive is standard. Powerful options include an internal multi-megabyte Winchester drive (available soon).

See the world's first 16-bit/8-bit computer kit, plus peripherals and

software...at your Heathkit Electronic Center.† Or mail the coupon today for a FREE Heathkit computer catalog!

H-100 SERIES COMPUTER SPECIFICATIONS:

USER MEMORY:
128K-768K bytes*

MICROPROCESSORS:
16-bit: 8088
8-bit: 8085

DISK STORAGE:
Built-in standard
5.25" disk drive,
320K bytes/disk

KEYBOARD:
Typewriter-style,
95 keys, 13
function keys,
18-key numeric pad

GRAPHICS:
Always in graphics mode.
640h/225v resolution;
up to eight colors
are available**

*128K bytes standard.
**Optional.

COMMUNICATIONS:
Two RS-232C Serial
Interface Ports and
one parallel port

DIAGNOSTICS:
Memory self-test
on power-up

AVAILABLE SOFTWARE:
Z-DOS (MS-DOS)
CP/M-85
Z-BASIC Language
Microsoft BASIC
Multiplan
SuperCalc
WordStar
MailMerge
Data Base
File Manager
Most
standard
8-bit CP/M
Software

Buy from
the leader in
electronic kits
and save!

†Heathkit Electronic Centers are units of Veritechnology Electronics Corporation. Heath Company and Veritechnology Corporation are subsidiaries of Zenith Radio Corporation. Prices, product availability and specifications are subject to change without notice.

Installing the uucp Programs

Installing the uucp programs is the first major hurdle a prospective Usenet site must clear. Some manufacturers of Unix systems, such as Intel, which makes the Xenix-based 86/330 system, are currently supporting uucp versions that are known to work. Although Microsoft's Xenix and Uniplus' standard distributions include cleaned-up and newly documented versions of uucp, direct support from software suppliers ranges from limited to nonexistent.

The uucp programs were developed for much more restricted networking than they are currently being asked to sustain for Usenet and other uses. According to Mark Horton, the uucp programs have not been thoroughly revised since 1978, and they've needed many patches and fixes since then. Fortunately, Usenet itself has been the means of distributing many of these improvements, but most people who have tried to install the uucp programs would agree that they are remarkably temperamental. Paul Miller of Horizon Software Systems, who is currently writing a book with Charles Clanton on Unix system administration, enjoys using uucp but admits that the best way to get it up and running might be to hire someone who's done it before.

While I don't intend to provide here a complete guide to installing uucp, I can offer a few handy hints for system managers. Volume 1 of the *UNIX Programmer's Manual* (New York: Holt, Rinehart & Winston, 1983) provides additional instruction in the use of uucp under entries for uucp, uux, and mail. Tutorial papers, "A Dial-up Network of Unix Systems" and "Uucp Implementation Description" are included in volume 2 (part B).

Some of uucp's problems result from the nature of its assigned task. The ability of one system to log into another system (usually as a user named uucp) and receive or send files represents a fundamental breach of system security unless authorized access is verified. Many of uucp's failures are caused by lack of permission at some point in the transaction.

Every file in the Unix file system is

Get your full-color

FREE

Heathkit
Computer
Catalog!



Heathkit

Heath
Company

CLIP COUPON AND MAIL TODAY TO:

Heath Company, Dept. 334-102
Benton Harbor, MI 49022

Please send my FREE Computer
Catalog, with details on the new
16-bit/8-bit H-100 Computer Kit, today!

Name _____

Address _____

City _____ State _____

CP-219 R1 Zip _____

We have CP/M[®] for Radio Shack computers.

2,000 new programs for your TRS-80[®] 12.

CP/M is the runaway leader in disk operating systems, but until now owners of Radio Shack computers have been locked out of the thousands of useful programs that operate on CP/M.

Now you can put the power of CP/M into your Radio Shack TRS-80 II, 12, or 16, and be able to use all the popular and useful software—and hardware—that has been previously out of your reach.

Use any printer.

Instead of being chained to Radio Shack hardware, you'll be able to add a video terminal, any printer (serial or parallel) and several Winchester hard disk drives with storage up to 80 megabytes.

Yes! Send me free information

about CP/M for Radio Shack.

Name _____

Address _____

City _____ State _____ Zip _____

Phone _____

or send us your business card.

Pickles & Trout[®], P.O. Box 1206, Goleta, CA 93116 (805) 685-4641

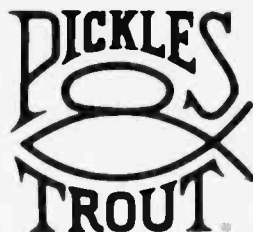

Uses only 8.5K of memory.

Since our first version went on the market in 1980, we've condensed and refined it into a compact, easy-to-use system enjoyed by thousands of users.

Besides the standard Digital Research CP/M manual, you'll get the 250-page manual we've developed through our long experience in adapting CP/M to Radio Shack computers. Our manual has lots of examples and an index and glossary.

You'll have your first working disk in ten minutes.

Only \$200.

The floppy disk version of Pickles & Trout CP/M is \$200. The hard disk versions (for Tandy, Corvus, and Cameo) are \$250, except for the multi-user Cameo, which is \$400.

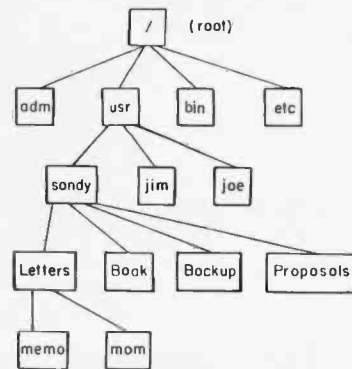

Figure 2: This diagram represents part of a Unix file system tree. Beginning with root (/), it shows four directories in root, three user directories, and four directories owned by sandy, one of which (Letters) contains two files.

flagged with a set of permission bits defining levels of access for the file's owner, the owner's group, and the general public. Access is defined as "read" (can read or copy), "write" (can edit), or "execute" (can execute a command or command file, or search a directory). Files are arranged hierarchically; beginning with the root of the file system, files are indexed in directories, which in turn point to other directories, and so forth (see figure 2).

The relationship of any file to the root directory is expressed as the file's path, which consists of directory names separated by slashes, ending in the file's name. For example, the file memo in the directory Letters might have the following path:

`/usr/sandy/Letters/memo`

(This user capitalizes the first letter of each of her directories so that they will be listed first in a directory listing.) The `usr` directory is a name conventionally given to the directory used to index the work of system users. When a user logs in, work is begun in the home directory, which usually has the same name as the account name. If the appropriate permissions are not in effect at any point in the path of a file involved in a uucp transaction, the transaction fails.

In addition to requiring appropriate permissions on the files and directories involved in uucp work, a number of system files are installed



Uncompromising Additions to your S-100/IEEE-696 BUS

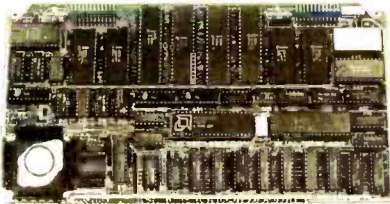

DUAL GPIB-488 INTERFACE BOARD

A Stand-Alone, Independently Controlled Dual Channel IEEE-488 I/O Processor. Interface Activity Modes for Controller-in-Charge, Controller Assigned or Terminal Bus Slave, and all Interface Functions are handled transparent to Host System CPU through an on-board CPU and DMA controller. User Friendly operation.

A&T, P/N 52748-800-102 \$675.00

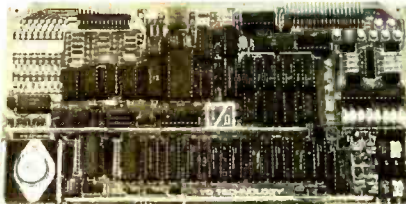

12-BIT A-D-A CONVERTER BOARD

8 Channel A-D: 12 microsec. Conversion, 50KHz Sample Rate, Programmable Gains, Offset and Diff./Single Modes.

8 Channel D-A: 2 microsec. Settling, Bipolar V or Unipolar I Output, Programmable Reference levels, Dual-Ported Channel Refresh RAM. **16/8-Bit Data Transfers** via I/O or Memory Mapped with Extended Addressing.

A&T, P/N 52748-900-101 \$455.00

MULTI-FUNCTION I/O BOARD

A&T, P/N 52748-100-101 \$325.00

SMART PROTOTYPING BOARD KIT

P/N 52748-400 \$60.00

California residents add 6% sales tax.
U.S. Domestic Price, FOB Factory.
Prices and Specifications subject to change without notice.

**I/O TECHNOLOGY
POST OFFICE BOX 2119
CANYON COUNTRY
CA 91351
(805) 252-7666**

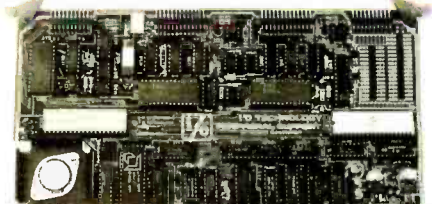

PERIPHERAL SUPPORT BOARD

Two Serial SYNC/ASYNCR Ports with RS-232, TTL or Current Loop Outputs, three 8-Bit Parallel Ports, three Timers, Real Time Clock/Calendar and Response Programmable Interrupt Controller. Small Proto Area with +5 and ±12v.

A&T, P/N 52748-150-101 \$395.00

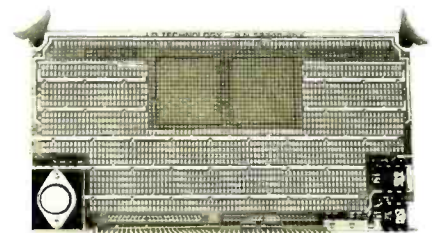

MULTI-PURPOSE PROTOTYPING KIT

Industrial Quality with Plated-Thru holes for Wire-Wrap or Solder projects. Complete with +5, ±12v Regulators, Bus Bar, Filter Capacitors, and Manual.

A&T, P/N 52748-450 \$70.00

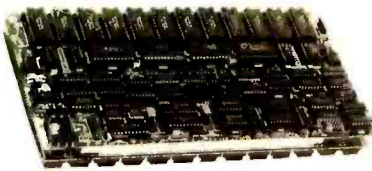

Top Board Support Logic and 32K x 8 RAM
Bottom Board 96K x 8 RAM

128K x 8/64K x 16 CMOS STATIC RAM MODULE

150 microsec. Access, Extended Addressing, Programmable wait cycles, Write protect and Bank select. Battery back-up capability. No wait cycles with fast 16-Bit Processors.

A&T, P/N 52748-550-128 \$825.00

in order to improve and refine uucp performance and security. These system files contain telephone numbers, site names, and access information used for linking to a remote machine.

The first requirement for performing uucp work is that a log-in name exist by which remote computers can identify themselves when they log in to your machine. Traditionally, the user name uucp is used, and an entry is made in the user account file, `/etc/passwd`.

Locations of uucp Programs and System Files

Most uucp programs and files are stored in four areas: a commands directory (such as `/usr/bin`), a library (`/usr/lib/uucp`), a system-administration directory (`/etc`), and the spooling directory (`/usr/spool/uucp`).

System files such as L-devices, L-dialcodes, L.sys, SQFILE, and USERFILE contain utility and security information. Each machine in the network has a uucp site name; a machine's own name is usually stored in a file in the

`/etc` system-administration directory (e.g., `/etc/systemname`). The library file L.sys records the names of remote machines that will be logging in as uucp on your machine. Your machine's name, in turn, must be installed in the L.sys files of machines that yours will log into. The L.sys file must list the site names and connection information for all machines with which you plan to connect. A password for the uucp user may also be included in the L.sys file entry. Here are some sample entries from an L.sys file:

```
frobish Any tty13 1200 tty13 login:-
EOT-login: uucp ssword: Uucp-ppswd
usxvax Any ACU 1200 6328792 login:-
EOT-login: uucp ssword: Uucp-ppswd
cranshaw Any ACU 300 sr6760884
login:-EOT-login: uucp ssword:
Uucp-ppswd
```

L.sys entries include the site name, calling times, the device and speed for the connection, and a simulation of the log-in sequence. The letters

ACU in the sample entries stand for automatic calling device (or auto-dialer), and a telephone number that will be used by the intelligent modem appears. If no ACU is mentioned, the connection is assumed to be hard-wired. Area codes and their abbreviations (such as "sr" for Santa Rosa, California) are stored in the L-dialcodes file, which is also in the library directory. The dashes and EOT symbols between log-in tokens indicate a pause, so that the modems and computers can synchronize with one another. Because the leading letters of "password" are usually lost in transmission, they are omitted in the L.sys file entry. There are many different opinions on the correct way to set up the L.sys file. Some installations, for example, also use ogin: for login:. If trial and error doesn't result in success, try to make your L.sys file congruent with those of the machines you will be calling. The L-devices file contains one entry for each device on which uucp may call out. For example:

PROGRAMMERS FLIGHT SIMULATOR
Apple II Plus DOS 3.3 48K



This total IFR System disk features gobs of menu selectable flight programs each with breath taking realistic picture graphics, moving scenery, airport approaches, holding patterns and much much more.

\$50.00 At your Computer Store or direct from
 Visa Mastercard

Programmers Software
 2110 N. 2nd Street
 Cabot, Arkansas 72023
 (501) 843-2988

PROGRAMMERS
"C" the extras we offer

C Compiler —

- Complete non-float implementation (float avail 3Q) per Kernighan and Ritchie.
- Small and medium models supported. Medium model allows greater than 64k of code and greater than 64k of data.
- Complete standard I/O package.

c-window™ — Source level debugger

- Fully interactive symbolic debugging.
- Full C expression evaluation during debugging.
- Statement and expression breakpoints.
- Automatic commands provide multiple variable display per single step or breakpoint.

Available for MSDOS systems

C Compiler \$195.00	c-window demo package
c-window \$195.00	(w/manual and diskette) \$45.00

c-systems P.O. Box 3253 • (714)637-5362
 Fullerton, CA 92634

c-window tm c-systems MSDOS tm Microsoft

ONLY THE WORLD'S BEST WORD PROCESSOR COULD GENERATE WORDS LIKE THESE.

"PIE:Writer, outscored every other word processing program for microcomputers...(It) crams an incredible amount of power into a small and inexpensive package...PIE:Writer beat four out of six dedicated word processors."

Arthur Naiman
"Word Processing Buyer's Guide"
McGraw Hill Book Company

"PIE:Writer is hard to beat..There is little I can't do with it..Do not fail to check out this program if you are a first time purchaser."

James Martellaro
Peelings II

"All in all, PIE:Writer is one of the most thorough word processing packages available...it can perform many functions in addition to word processing...PIE:Writer just may be the best buy."

Peter Olivieri
"Softalk"
March 1983

Why are some of the most respected authorities in the field of software saying all these nice things about PIE:Writer"? The answer is easy.

Easy to Learn. Easy to Use.

Part of the reason that PIE:Writer is the top ranked word processor is that it's just plain simple to run. In fact, you can use it as soon as you get it home. To write a letter, for instance, just (a) load the program, (b) type the letter 'E', and (c) write your letter. Then, (d) type 'F' to enter the print mode for either screen or paper and you're ready to print. You'll get a perfectly typed, spaced and formatted letter. Now what could be easier than that?

Powerful Features.

Don't confuse our use of the word simple with unsophisticated. PIE:Writer offers features and capabilities far beyond any other word processing programs for microcomputers. And that goes for most of the dedicated word processors as well. Here are just a few:

	Operating system(s) and/or machine(s)	Price	Overall Score
CPT 8100	dedicated word processor*	\$15,000	94 1/2
Dictaphone Dual Disp.	dedicated word processor*	\$13,500	85 1/4
PIE:Writer:	Apple II, IBM PC	\$149.95 \$199.95	84 1/4
WordStar	CP/M†, Apple II, IBM PC	\$500	80
Easywriter	IBM PC**	\$175	35

- A tutorial section that easily acquaints you with the features of the program in step-by-step transactions.

- You can customize the design of your letters and reports with integrated centering, bold facing, special tab features, mail merge capabilities, automatic page numbering, line lengths and much more.
- PIE:Writer is also compatible with both the Apple IIe and IBM Personal Computer and other popular compatibles.

The Hayden Advantage.

With thousands already in use, PIE:Writer is part of Hayden's growing "Personal Information Environment" family of software products. This includes PIE: Speller, a 20,000-word dictionary spelling checker with the ability to add user-specific dictionaries. You can expect some very exciting PIE additions in the near future. And naturally, full technical support from the company that has built its reputation on quality and service.

But don't take our word for it. Or the experts, either, for that matter. Try PIE:Writer for yourself and enjoy the ease and excitement of writing with the world's best word processor.

PIE:Writer

HAYDEN SOFTWARE

*Includes word processing hardware & multistation support. †Requires additional CP/M Hardware for your personal computer (\$200-600 extra). CP/M is a registered trademark of Digital Research. *VisiCalc © is a registered trademark of VisiCorp. **Very similar program called Easywriter Professional, available for the Apple II.

tty5 tty5 300
tty5 tty5 1200
tty2 0 9600

This sample L-devices file specifies that calls may be made at 300 or 1200 bps (bits per second) through device tty5. A hard-wire link to another machine through device tty2 operates at 9600 bps. If the L-devices file is empty, the site is defined as passive—incapable of calling remote machines.

USERFILE

The USERFILE restricts a local or remote uucp user's ability to access the local file system. Each entry in USERFILE may contain a user ID, a site name, and one or more path names. Each line specifies what areas of the file system a given user may access. The user can be a person logging into the system or a computer calling to perform uucp work.

For example, USERFILE could contain:

```
, /usr/public  
root, /  
uucp, /usr/public /usr/spool/uucp
```

The first entry allows any user (indicated by a null field followed by a comma) access to files beginning with the prefix /usr/public. The second entry allows the user root to access files beginning with the prefix "/"; this means those beginning with the root directory and extending to the whole file system. The third entry specifies that any remote computer logging in as uucp can access files beginning with the path /usr/public or /usr/spool/uucp.

Frequently, a shell script will be supplied with your uucp programs that will correctly set up the ownership and permission structure for the uucp files and programs. If no such script exists, a list of ownership and permission requirements is provided in the tutorial on uucp implementation.

Information about uucp transactions is accumulated in several record-keeping files in the /usr/spool/uucp directory. Periodically, old log files should be removed in order to recover disk space. The secondary programs uulog and uuclean aid in maintenance work: uulog updates the uucp log file or, optionally, reports on its contents; uuclean removes old files from the spool directory.

Testing uucp

The quickest way to test whether you have correctly set up the UUCP system files is to copy a file to another place on the local system, using the -x9 option to provide the maximum amount of debugging information. Once you succeed (return status 0), you can try calling or being called by a remote system. Of course, you must first telephone someone at the other end of the potential connection so that you can install each other in your system files in an agreed-upon way.

The syntax of the uucp command requires that each remote system name be followed by an exclamation point. Because uucp cannot deduce routing information on its own, each site name in a machine-to-machine

beautifully NEW...incredibly effective



stop your CRT from being an eyesore

Any computer terminal operator will verify how tiring, frustrating, and downright inefficient CRT glare can be. Now, thanks to Optech CRT filters, this hassle can be eliminated.

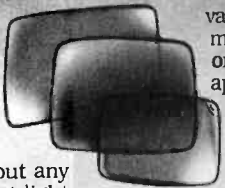

Attached in minutes without any tools, Optech diffuses ambient light (external light) while dramatically improving contrast. The result? Data displayed as never before—clear, bright, and without interference. And since Optech CRT filters come in a

variety of sizes to custom fit the most popular computer terminals on the market today, they actually appear to be built into the terminal when attached. Beautiful? Of course. Both in its effectiveness and appearance. And its price tag is less than an inexpensive program.

But you be the judge. Call toll free for your nearest Optech dealer. You'll see how to quickly, economically, and efficiently say good-bye to the CRT eyesore forever.

CALL TOLL FREE AT 800-346-7802

SGL HOMALITE CORPORATION 11 Brookside Drive • Wilmington, Delaware 19804 • Telephone 302-652-3686
A subsidiary of SGL Industries, Inc.



\$\$ "LOWEST PRICES" \$\$



SMITH CORONA

LETTER QUALITY PRINTERS SMITH CORONA TP1 \$482

STARWRITER 40 CPS S or P .. \$1274
PRINTMASTER 55 CPS S or P .. 1544
NEC 3510 33 CPS SERIAL .. 1386

DOT MATRIX PRINTERS

GORILLA BANANA Graphics \$221
EPSON
MX-80 w/Graphics Rom +, 80 cps .. 427
FX-80 Friction & Tractor 160cps .. 595
MX-100 Friction & Tract. 100cps .. 653
STAR MICRONICS
GEMINI 10 2.3K Buffer 100 cps .. 329
GEMINI 15 15" Carriage .. 494
OKIDATA
82A Serial & Parallel 120 cps .. 409
84 Parallel 15" Fr&Tr 200 cps .. 1005
92 Parallel 10" Fr&Tr 160 cps .. 514
PROWRITER 8510 10"Par 120cps 404
8600-Near Letter Quality Par 1031
PRISM 80 .. 974

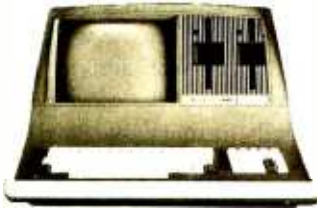

SUPERBRAIN

SUPERBRAIN II
DOUBLE DENSITY .. \$1970
QUAD DENSITY .. 2376
SUPER DENSITY .. 2684
COMPUSTARS FOR NETWORKING
VPU-10 .. CALL
VPU-20 .. CALL
VPU-30 .. CALL
VPU-40 .. CALL
DSS-10 .. CALL

AMERICAN SQUARE COMPUTERS is organizing a World Wide Association of Computer Dealers. Open a Store or Start Work Out of Your Home! We Charge NO FRANCHISE FEE! (Our Competitors charge a FRANCHISE FEE of from \$15,000.00 to \$45,000.00.) Be a Winner! Let US help YOU get started MAKING MONEY by HELPING PEOPLE to put COMPUTERS to WORK. Write or Phone today.

Which Computers are Best? ... Free
Insured Shipping at Low Rates.

ADVANCED DIGITAL

S-100 SUPER QUAD SINGLE BOARD
COMPUTER Z-80 64K RS232 DISK
CONTROLLER FOR 5" OR 8" .. \$474
SUPER SLAVE 128K + PS NET/1 .. 437
SUPER SIX/128 6 MHZ 128K .. 555
TURBODOS SINGLE USER .. 250
SUPER SYSTEM-DD-8 .. 2327
SUPER SYSTEM-8-HD-10 .. 3920

ALTOS COMPUTERS

586-10 16 bit 12Mb HD .. \$5830
8000-2 64K RAM .. \$2680
8000-15 208K RAM .. 3653
8000-10 208K RAM .. 5571
5-15D 3 USER 2 5 1/4" .. 2201
5-5D 3 USER HARD DISK .. 4379
8600-12 16 BIT 20 MB HD .. 9104

TRAXX 5 1/4" ADD ON DRIVES

Bare drive SSDD Quantity 2 Ea ... 215
SSDD w/cabinet & power sup. 312



TELEVIDEO

TERMINALS

TELEVIDEO 910 .. \$419
TELEVIDEO 925 Detach Keybd .. 674
TELEVIDEO 950 Prog func keys .. 863
TELEVIDEO 970 VT-100 compat. .. 935
ADDS Viewpoint 3A+ Emulates .. 458
ADDS Viewpoint 60 Graphics .. 620
ADDS Viewpoint 90 Prog. EPROM .. 820
ADDS Color Terminal NEW! .. 998
Zenith Z-29 Z19&VT100 compat .. 655
Zenith ZT-1 Terminal+modem .. 460
Visual 50 Ergonomic .. \$545
Visual 55 New! Enhanced #50 .. 626
Visual 100 80/132 columns .. 890
Visual 400 ANSI x3.64 compat .. 1074
Visual 500 Graphics 14" screen .. 1646
TELEVIDEO 914 Detach Keybd .. \$506
TELEVIDEO 924 NEW .. \$614

MONITORS

ZENITH
ZVM 121 Green Phosphor .. \$123
ZVM RGB Color Monitor .. 545
GDZ-13-14 Composite Color .. 325

NEC

JC1201M 12" Composite Color .. \$378
JC1202DHA 12" RGB Color Mon. .. 810
JB1201M 12" Green phosphor .. 176

AMDEK

Color I Color monitor .. \$321
300G 12" Green .. 165

GRAPHICS & COLOR GRAPHICS

VECTRIX

VX 128 8 colors 322x560 Pix. ... \$2245
VX 384 16.8 million colors .. 3865
VXM Hi Res. 13" RGB Monitor .. 1430

MICROANGELO

MA 512 512x480 Monochrome .. \$674
MA 520 512x480 + Screen Pak2 .. 890

COMPUTERS

COMPUPRO

Compupro computers come as mainframe, boards, and drives, and you must set the switches.

816A Computer 8085/8088 128K .. \$3964
816B Computer 8085/8088 256K .. 5038
816C 8085/8088 384K 3 users .. 6470
816D 10 MHZ 8086 512K .. 10052
816-08 CPUZ 208K Oasis .. 6471
816-016 10 MHZ 8086 512K .. 10052

SEATTLE Pure 16 bit computer is the fastest microcomputer by actual test! S-100, 128K Static Ram, 8 MHz 8086 18 slot, Mainframe, 3 serial & 1 parallel ports.

Gazelle II computer .. \$4346
Hard Disk Gazelle II .. 5750

RADIO SHACK TRS-80 SAVE! CALL

TARBELL with 2-8" disk drives
EMPIRE I single sided .. \$3304
EMPIRE II double sided .. 3775

MEDICAL SOFTWARE

MICROMED & MICRODENT .. 1656
STARDOC .. 350
THE DOCTOR'S OFFICE NEW! CALL



NORTH STAR ADVANTAGE

North Star Advantage 8 BIT 8/16
Work Station .. \$1918 \$2281
2 Floppies 360K ea. ... 2252 2542
5 Mb Hard + 360K Floppy .. 3362 3652
15 Mb Hard + 360K Floppy .. 4385 4748

NORTH STAR HORIZON

HORIZON 1 User Multi
2 Floppies 360K ea. ... \$2252 N/A
5 Mb Hard + Floppy .. 3362 \$6095
15 Mb Hard + Floppy .. 4385 6821
18 Mb Hard + Floppy .. 5837 8273



Morrow Terminal

Micro Decision II

MICRO DECISION

"A DEAL YOU CAN'T REFUSE"

64K RAM Z80 4MHz 2 serial ports
5 1/4" disks Free Software — CPM 2.2
MicroSoft Basic, BaZic, WordStar
LogiCalc spreadsheet, Correct-it

ONLY
MD11 10Mb + 400K FL + Morrow Term. .. 2139
List 2745

MD2 2-5" SS drvs + Per. Pearl .. 828
MD2 +ADDS 3A+ Terminal .. 1279
MD2 +ADDS 3A+ +Smith Corona 1779

MD3 2 sided drives & Bookkeeping & Personal Pearl. FANTASTIC BUY

MD3 2 Double sided drives .. 1055
MD3 +ADDS 3A+ Terminal .. 1508
MD3 +ADDS 3A+ +Smith Corona 2008
Above Packages include all Cables

DECISION I

"IBM-360 on the Z-80 & S-100 Bus!"

Sixteen programs running simultaneously! FREE CPM, MicroSoft Basic, S-100, IEEE 696, 14-slot, 4 MHz Z80 Real time clock, Interrupts, 3 Serial & 1 parallel port. 64K static RAM expandable to 1 Megabyte.

D100 Hardware & Software as above \$1783
D120 1 DSSD 5 1/4" + 10 Mb HD
+Wordstar, Correct-It, LogiCalc, BaZic, and Personal Pearl \$3538

D200 = D120 + MOS, Multiuser \$3889
D210 w/15Mb HD plus MOS .. \$4240
D220 w/15Mb HD 6 user .. \$5293

MOS Multiuser upgrade to 256K RAM .. 734
+Micronix operating system .. 1432

MOS+ with above & Whitesmith's C & Pascal .. 1117

MORROW DISK DRIVES

Complete systems include S-100 controller, power supply, cabinet, & fan. CPM & Basic 80
Add Drives include power supply, cabinet & fan.

	System	Add Drive
5 1/4" Winchester	5Mb \$1432	\$1011
5 1/4" Winchester	15Mb 1713	1362
8" Winchester	10Mb 2625	2134
8" Winchester	20Mb 3187	2766
5 1/4" Winchester	10Mb 1572	1081
8" (w/DMA controller)		
One 1 sided ..	\$870	\$576
One 2 sided ..	1081	800
Two 1 sided ..	1418	1011
Two 2 sided ..	1839	1432

Call for latest prices & availability

Factory Guarantees

We Beat Prices

AMERICAN



COMPUTERS

919-889-4577

4167 Kivett Dr.

Jamestown N.C. 27282

919-883-1105

Circle 33 on inquiry card.

BYTE October 1983 235

path must be included on the command line. For example,

```
uucp -x9 /user/sandy/Letters/memo
frobish!usxvax!cranshaw!usr/arnold
```

would copy sandy's memo file to the arnold directory on the cranshaw machine via machines frobush and usxvax.

Currently, more than 1500 Unix systems are known to be uucp sites. A Usenet news group lists contact information for many of these machines. Mail and file-transfer services, as well as the Usenet news service, are supported.

On the Network

Once you have established a uucp link to your nearest Usenet neighbor, you can copy over the news programs and install them. Matt Glickman has written a *USENET Version B Installation Guide*, which should be part of the initial documentation you receive. One of the first articles you submit should go to net.news.newsite in order

to provide contact information for use by the network. If you are planning to forward news to other sites, you must also install their site names and the names of the news groups to be forwarded in a sys file, which is similar to uucp's L.sys file.

Like other Unix programs, the news programs are simple commands with a number of options. On one command line, you specify what you want to do to whom and to what extent.

The basic Usenet news command is readnews, which forwards news to you from a default subscription list. Any user can custom-tailor the subscription list by creating a .newsrc file in the home directory. The news programs automatically update the .newsrc file with the number of news articles that have been read. A roughly accurate list of active news groups can be obtained by listing the news spooling directory, /usr/spool/news.

As each article is presented, a header indicates the name of the author, the subject, and the length of

the article (in number of lines). A more detailed header giving the transmission path of the article is shown on request. Entering a question mark will get you the complete list of news commands. A number of responses are possible; you can read all or part of an article, decline to read an article, skip to the next news group, or reply to any item. When you use the quit command (q), a record is made of which articles you read or refused, and you then exit from netnews.

Usenet is remarkable for its nationwide scope and density of information flow, but in many respects it resembles other bulletin-board systems. Much of the dialogue concerns the operation (or nonoperation) of software, including the news programs themselves. Useful information is present but may be buried in a host of humdrum commentaries and rather trivial complaints. If you're patient and persistent, though, the occasional gems can make reading all that other news worthwhile. Moreover, some of the articles indicate that reading and writing the news can also be a satisfying social activity for network members.

What is really remarkable is that the whole Usenet structure has been built and maintained by volunteers and that thus far no heavy-handed central administration has been necessary. Usenet is an egalitarian communications medium, still open to new members because of the good will of its current members. The implicit social contract that exists among Usenet members—to forward news, respond to requests for information, and participate in network maintenance—will continue to be a vital part of Usenet. ■

Acknowledgment

Thanks to James Joyce, who runs *International Technical Seminars and The UNIX Bookstore*, for suggesting this article and providing invaluable advice and support.

Sandra L. Emerson (309 63rd St., Apt. D, Oakland, CA 94618) is a freelance technical writer and coauthor of a book on the Unix operating system. She holds a B.A. in English from Duke University and an M.S. in health education from the University of Toronto.

Treat your personal computer to famous Diablo letter-quality printing.

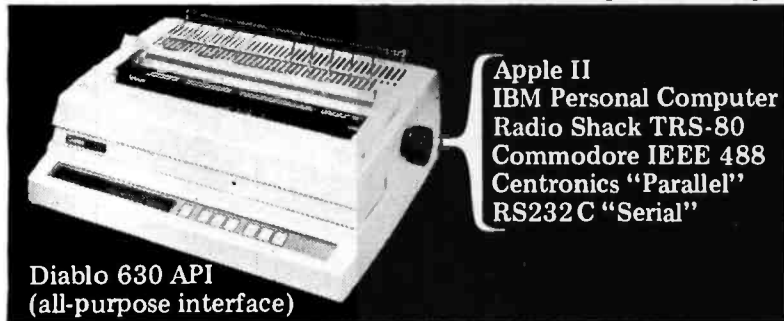

Diablo 630 API
(all-purpose interface)

MTI has the new Diablo 630 API ready for you.

Don't settle for less: up to 40 cps, your choice of over 200 metalized or plastic printwheels, in MTI's opinion the best letter-quality printer on the market today. And at MTI's best price.

Whether you rent, buy or lease our equipment, you'll find MTI is the one source for all the terminals, peripherals, systems, applications expertise and service you'll ever need. At good prices. Call us today.

New York: 516/621-6200, 212/767-0677, 518/449-5959
Outside N.Y.S.: 800/645-6530
New Jersey: 201/227-5552
Ohio: 216/464-6688

"QED" Discounts
VISA & MasterCard



Diablo® Authorized
Distributor

Applications Specialists & Distributors, New York, New Jersey and Ohio.
DEC, Intel, Lear Siegler, Texas Instruments, Dataproducts, Diablo, 3Com,
Hazeltine, Racal-Vadic, Digital Engineering, MICOM, Cipher, U.S. Design,
Protocol Computers, MicroPro, Microsoft, Polygon and Select.

MicroAge[®]

**"BECAUSE WE COULDN'T
AFFORD MISTAKES!"**

"They guided us over the rough parts when we needed it"

"During September of 1982, we started our MicroAge Computer Store in Tulsa, Oklahoma with 3 people. Today we have 11 people working for us and we're still hiring. By following MicroAge's advice and marketing strategy when we started in business, we were able to reach Tulsa's business computer buyers in a much shorter time than we could have on our own."

"Both of us had technical backgrounds in computers but lacked the marketing experience necessary to reach our goals. We used MicroAge's experience and leadership to guide us through the rough spots and boost our sales and marketing potential."

"MicroAge...they helped us build a sales organization to reach the Oklahoma businessman."

John E. Moiser
John Moiser
President

George B. McLawhon
George McLawhon
Vice President

To build your own professional computer sales organization with MicroAge write to:

MicroAge[®]
COMPUTER STORES

"The Solution Store"

1457 West Alameda • Tempe, Arizona 85282

(602) 968-3168

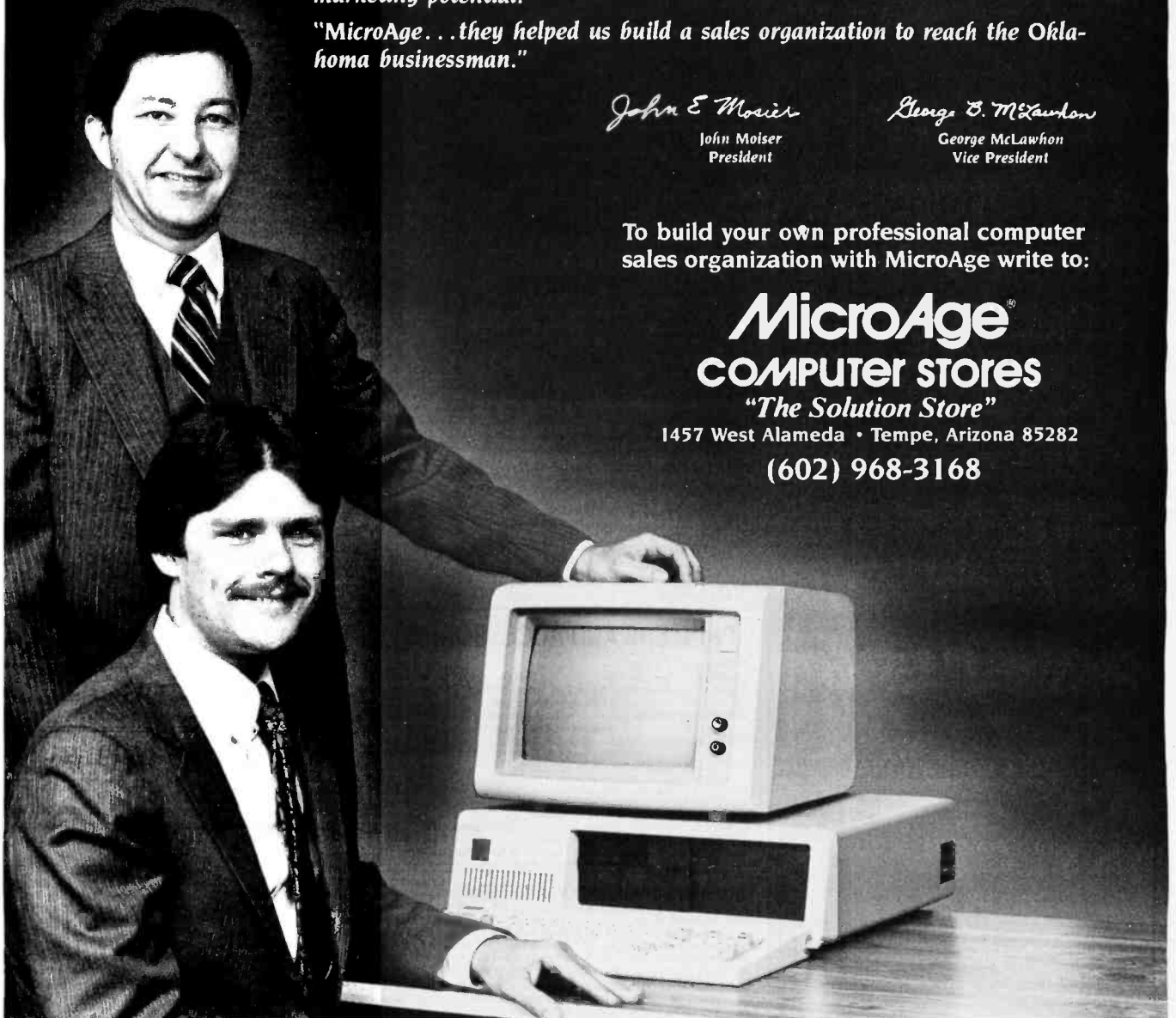

MicroAge franchisees John Moiser and George McLawhon shown with IBM products.

Circle 293 on inquiry card.

The Choice of

SAVE THIS AD IT IS YOUR CATALOG AND CHANGES MONTHLY

Conroy-LaPointe — The Supply Center for the IBM-PC or XT

SOFTWARE for the IBM-PC or XT

BUSINESS

	LIST PRICE	OUR PRICE
ASHTON-TATE dBase II, requires PC-DOS & 128K	\$ 700	\$ 395
dBase II User's Guide by Software Bank	\$ 30	\$ 20
Everyman's DB Primer (Book)	NEW! \$ 15	\$ 12
The Financial Planner	NEW! \$ 700	\$ 419
Friday	NEW! \$ 295	\$ 199
APPLIED SOFTWARE TECHNOLOGY, Versatorm	\$ 389	\$ 265
CONTINENTAL, The Home Accountant Plus	\$ 150	\$ 112
FCM (Filing, Cataloging, Mailing)	\$ 125	\$ 85
Property Management	\$ 495	\$ 329
DATAMOST, Real Estate Investment Program	NEW! \$ 130	\$ 89
Write-On (Word Processor Program)	\$ 130	\$ 89
DIGITAL RESEARCH, Concurrent CP/M-86™	\$ 350	\$ 235
CBASIC 86™	\$ 200	\$ 159
CP 86™	\$ 60	\$ 40
DOW JONES, Market Analyzer	\$ 350	\$ 279
Market Manager	\$ 300	\$ 239
EAGLE SOFTWARE, Money Decisions	NEW! \$ 150	\$ 129
FOX & GELLER, Quiccode (MSDOS)	\$ 295	\$ 179
diagraph (MSDOS, requires color graphics adaptor)	\$ 295	\$ 179
Unit for IBM PC DOS	\$ 99	\$ 59
HAYDEN, IBM Pie Writer	NEW! \$ 200	\$ 135
HOWARDSON, Real Estate Analyzer II	\$ 250	\$ 189
INFORMATION UNLIMITED, EasyWriter II (Word Processor)	\$ 350	\$ 259
EasySpeller II (88K Words)	\$ 225	\$ 149
EasyWriter II (88K Words)	\$ 409	\$ 299
EasyWriter III (a DBMS)	\$ 495	\$ 329
INNOVATIVE SOFTWARE, TIM II (a DBMS)	\$ 225	\$ 159
INSOFT, Data Design (a powerful easy to use DBMS)	NEW! \$ 17	\$ 12
Data Base Made Easy (Book)	NEW! \$ 495	\$ 329
LOTUS, 1-2-3	NEW! \$ 995	\$ 699
MICROCRRAFT, Verdict (Legal) or Billkeeper, each (CP/M86)	\$ 495	\$ 329
MICROPRO, WordStar™ plus free WordStar Training Manual	\$ 495	\$ 329
MailMerge™ (Call on 2 Pak, 3 Pak and others)	\$ 250	\$ 129
SpellStar™	\$ 250	\$ 129
WordStar Professional, 4 Pak, 3 above + StarIndex	\$ 895	\$ 429
StarIndex™	NEW! \$ 195	\$ 109
InfoStar™	\$ 495	\$ 329
Report Star™	\$ 350	\$ 199
Multiplot, Multipan	MSDOS NEW! \$ 275	\$ 189
Multiplot, Word	MSDOS NEW! \$ 375	\$ 275
Multiplot, Word with Mouse	MSDOS NEW! \$ 475	\$ 350
Multiplot, Financial Statement	MSDOS NEW! \$ 100	\$ 75
Multiplot, Budget	MSDOS NEW! \$ 150	\$ 115
muMath muSimp	NEW! \$ 300	\$ 225
Business BASIC Compiler	MSDOS NEW! \$ 600	\$ 450
Pascal Compiler	MSDOS NEW! \$ 350	\$ 260
C Compiler	MSDOS NEW! \$ 500	\$ 375
BASIC Compiler	MSDOS NEW! \$ 395	\$ 295
Fortran Compiler	MSDOS NEW! \$ 350	\$ 259
COBOL Compiler	MSDOS NEW! \$ 750	\$ 559
BASIC Interpreter	MSDOS NEW! \$ 350	\$ 259
MULTISOFT, StretchCalc (makes a close Lotus out of Visicalc)	NEW! \$ 99	\$ 59
NORTH AMERICAN BUS SYSTEM, The Answer	\$ 250	\$ 169
OSBORNE COMX (Book & Disk, Business, Statistics & Math Programs)	\$ 100	\$ 69
Some Common BUS Programs (70 programs)	\$ 100	\$ 69
Practical Basic Programs (40 more programs)	\$ 145	\$ 99
PBL CORPORATION, Personal Investor	\$ 595	\$ 365
PEACHTREE SOFTWARE, Peach Pak 4 (GL, AR & AP)	NEW! \$ 395	\$ 299
Peach Text 5000	\$ 389	\$ 149
PERFECT SOFTWARE, Perfect Writer™	\$ 295	\$ 99
Perfect Speller™ or Perfect Calc™, each	\$ 595	\$ 199
Perfect Filer™	NEW! \$ 140	\$ 95
SOFTWARE PUBLISHING, PFS: File	\$ 125	\$ 85
PFS: Report	\$ 295	\$ 199
SORCIM ISA, SuperCalc II	\$ 395	\$ 269
SuperWriter	\$ 150	\$ 99
SYNAPSE, Free Manager	\$ 250	\$ 169
SYNERGISTIC, Data Reporter	\$ 275	\$ 169
T. MAKER, T. Maker II	\$ 250	\$ 179
VISICORP, VisiCalc™ 256K	\$ 250	\$ 199
VisiDev or VisiSchedule, each	\$ 250	\$ 199
VisiFile or Desktop Plan II, each	\$ 300	\$ 239

UTILITY

CENTRAL POINT Copy II PC Backup and Utility	NEW! \$ 40	\$ 35
COMX Fasttrak™ RAM Disk emulator and printer spooler program	Works \$ 100	\$ 59
or any PC DOS version or RAM Card, Menu Driven	NEW! \$ 119	\$ 69
HAYES Smartmodem II	\$ 119	\$ 69
MICROCOM, Microterm™	\$ 35	\$ 25
NAGY SYSTEMS, Copy PC Backup and Utilities	\$ 35	\$ 25
NORELL, DATA System Backup	\$ 50	\$ 39
NORTON, Norton Utilities, 14 powerful programs, 3 disks	\$ 80	\$ 65

HOME & EDUCATIONAL

EPYX Automated Simulations, Temple of Apshai	\$ 40	\$ 29
Ol Barons	NEW! \$ 100	\$ 75
ARMONX Executive Suite	\$ 40	\$ 27
BLUE CHIP Millionaire	\$ 60	\$ 39
BPI SYSTEMS, Personal Accounting	\$ 195	\$ 139
CONTINENTAL, The Home Accountant Plus	\$ 30	\$ 22
SPODE RBLIND Apple-Plan	\$ 150	\$ 112
DATAMOST, Pkg Pen or Space Strike, each	\$ 75	\$ 55
DAVIDSON, The Speed Reader II	\$ 50	\$ 39
INFOCOM, Deadline	\$ 50	\$ 39
Zork I or Zork II or Zork III, each	\$ 40	\$ 29
INSOFT, Word 1 or Quota or Mystix, each	NEW! \$ 35	\$ 29
MICROSOFT Flight Simulator (by Sub-Logic)	NEW! \$ 50	\$ 35
PBL CORP., Personal Investor	\$ 145	\$ 99
SPINNAKER Snopner™ #1 or #2, each	\$ 45	\$ 35
Slovy Machine or Face Maker or Rhymes & Riddles, ea	\$ 35	\$ 25
STRATEGIC, The Warp Factor	\$ 40	\$ 30

IBM is a trademark of IBM Corporation

IBM-PC

System Includes
Two 320K Disk Drives by CDC
90 Day Warranty By Us
Call For Details And Configurations



HARDWARE

MEMORY CHIP KITS Add-on to your memory cards or mother board. 100% tested. With 90 day warranty.

	LIST PRICE	OUR PRICE
64K Kit, 200NS, 9 chips, 4164	\$ 150	\$ 45
16K Kit, 200NS, 9 chips, 4116 for PC-1 motherboard	\$ 30	\$ 16
AST Combo Plus, 64K w/async para & clock/calendar	\$ 395	\$ 279
Above Combo Plus, 256K, S/P/C	\$ 695	\$ 525
CCS SuperVision, monochrome 132 Col., 44 line video board	\$ 850	\$ 680
Z-Plus 64, last, 280B, 64K (expand to 192K), para port	\$ 875	\$ 695
ComX 256K RAM Card with Fasttrak™ RAM disk emulator	\$ 695	\$ 256
and printer spooler software, 2 Year Warranty		
CURTIS PC Pedestal™ for Display on 9"	\$ 80	\$ 65
9 Foot Cable for IBM Keyboard (extends 3' to 9')	\$ 50	\$ 35
Key Tronic, KBS150, Standard Typewriter keyboard	NEW! \$ 269	\$ 199
MICROSOFT 64K RAM Card w/Parity	\$ 350	\$ 250
256K RAM Card w/Parity	\$ 875	\$ 625
64K System Card, 4 Function	\$ 395	\$ 295
256K System Card, 4 Function	\$ 625	\$ 465
MBI Monte Carlo 64K Five Function (to 1000K)	\$ 625	\$ 395

	LIST PRICE	OUR PRICE
QUADRAM Quadcolor I	\$ 295	\$ 235
Quadcolor II, use with Quadcolor I, set 640x200	\$ 275	\$ 209
Microtazer, w/Copy, Par/Par, 8K, #MP6 w/Power Supply	\$ 189	\$ 139
Microtazer, w/Copy, Par/Par, 64K, #MP6 w/Power Supply	\$ 319	\$ 235
Microtazer, w/Copy, Par/Par, 128K, #MP128 w/Power Supply	\$ 465	\$ 345
Microtazer, Snap-on, 8K, Par/Par, Epson, #ME6, w/Power Supply	\$ 179	\$ 145
Microtazer, Snap-on, 64K, Par/Par, Epson, #ME64, w/Power Supply	\$ 319	\$ 235
All Microtazers are expandable (w/copy to 512K) (Snap-on to 64K)		
TG PRODUCTS, Joystick	\$ 65	\$ 49

DRIVES

	LIST PRICE	OUR PRICE
CONTROL DATA OR Tandon Disk Drives		
★ DISK DRIVES, Double Sided 360K/320K. Same as now supplied with IBM-PC & XT. Tested, burn-in. With installation instructions		
60 day warranty by us.	1 each \$ 529	\$ 249
	2 or more \$ 529	\$ 239
Hall Height 360K or 320K Drives, same as above	\$ 395	\$ 199
★ DAVONG INTERNAL Hard Disk, 5-6MB	\$ 1995	\$ 995
(FOR PC-1, complete) CLOSURE OUT		
MAYNARD, Floppy Drive Control Board, for up to 4 drives, same with Parallel Port	\$ 195	\$ 165
	\$ 275	\$ 205
VISTA IBM-PC/XT 6MB Backup for Hard Disk, V1200	\$ 1549	\$ 1049

PRINTERS AND ACCESSORIES

	CALL PRICE	CALL PRICE
EPSON MX or FX PRINTERS		
LEADING EDGE, Gonlia Banana	NEW! \$ 250	\$ 209
OKIDATA, Microline 82A, 80 col., 120 cps, Para., friction & pin feed	\$ 549	\$ 419
83A, 132 col., 120 cps, Para., friction & tractor feed	\$ 899	\$ 729
PRACTICAL PERIPHERALS, Microbuffer In-Line 64K, Parallel	\$ 349	\$ 259
Microbuffer In-Line 64K, Serial	\$ 349	\$ 259
★ STAR MICRONICS, 9x9 Dot Matrix, 120cps, 2.3K, Gemini 10 X	\$ 499	\$ 289
9x9 Dot Matrix, 100cps, 2.3K, Gemini 15™	\$ 649	\$ 489
IBM-PC to Epson or Star Micronics Cable	\$ 60	\$ 35
Apple Interface and Cable for Epson or Gemini	\$ 95	\$ 59
Grappler - by Orange Micro, specify printer	\$ 165	\$ 119
Apple Graphics Dump Program by Epson	\$ 15	\$ 9
LETTER QUALITY - DAISY WHEEL PRINTERS:		
COMREX, Comiter CR-1, 1F, 200 wpm, Serial	Limited Special \$ 1199	\$ 545
TTX, 13 cps, 10-12-15 Pitch, Para, 8 Ser, Pin & Friction	\$ 649	\$ 499
SUPPLIES: Tractor Feed Paper, Ribbons, Heads, Cume Daisy Wheels and Ribbons		

ORDERING INFORMATION AND TERMS: All Mail: P.O. Box 23068, Portland, OR 97223. Include telephone number. All items usually in stock. We immediately honor Cashiers Checks, Money Orders, Fortune 1000 Checks and Government Checks. Personal or Company Checks allow 20 days to clear. No C.O.D. Prices reflect a 3% cash discount so ADD 3% to above prices for VISA or MC. For U.S. Mainland, add 3% for shipping, insurance and handling (S/H) by UPS with \$5 minimum for S/H. UPS ground is standard so add 3% more for UPS Blue with \$10 minimum for S/H. Add 12% total for S/H for US Postal, APO or FPO with \$15 minimum for S/H. For Hawaii, Alaska and Canada, UPS is in some areas only, all others are Postal so call, write, or specify Postal. Foreign orders except Canada for S/H add 18% or \$25 minimum for S/H (except for monitors add 30% or \$50 minimum for S/H). Prices subject to change and type errors, so call to verify. All goods are new, include warranty and are guaranteed to work. Due to our low prices, ALL SALES ARE FINAL. Call before returning goods for repair or replacement. Orders received with insufficient S/H charges will be refunded. ORDER DEADLINE HOURS 6 A.M. to 6 P.M. PST, Monday through Friday and 10 A.M. to 4 P.M. EST, Saturday. 6 A.M. here is 9 A.M. in New York.

OUR REFUNDING: We have been in computers and electronics since 1958, a computer dealer since 1979 and in mail order since 1980. Banks: 1st Interstate Bank, (503) 643-4678. We belong to the Chamber of Commerce (503) 644-0123, Better Business Bureau (503) 227-0648 and Direct Marketing Association, or call Dunn and Bradstreet if you are a subscriber. Fasttrak™ and Genem™ are trademarks of ComX Corporation. WordStar, MailMerge, StarIndex, InfoStar, are trademarks of MicroPro.

8" CP/M-80 SOFTWARE MUCH MORE IN STOCK

	LIST PRICE	OUR PRICE
ASHTON-TATE dBase II	\$ 700	\$ 395
MICROCRRAFT, Verdict (Legal) or Billkeeper (Professional), each	\$ 395	\$ 269
MICROPRO, WordStar™ plus free WordStar Training Manual	\$ 495	\$ 239
MailMerge™ (Call on 2 Pak, 3 Pak and others)	\$ 250	\$ 129
WordStar Professional, 4 Pak, 3 above + StarIndex	\$ 895	\$ 429
MICROSOFT Multiplan	\$ 275	\$ 199
Fortran 80 Compiler	\$ 500	\$ 325
BASIC Compiler	\$ 395	\$ 295
COBOL-80 Compiler	\$ 750	\$ 545
multiSp muStar-80	\$ 200	\$ 145
Macro-80	\$ 200	\$ 145

MONITORS AND ACCESSORIES

AMDEK, 12" Green, #300G	\$ 200	\$ 159
★ 12" Amber, #300A	\$ 210	\$ 159
★ 12" Amber, 310A for IBM-PC/XT	\$ 230	\$ 169
★ 13" Color I, Composite	\$ 379	\$ 299
★ 13" Color II, RGB, Hi Res (Ap. II, III & IBM-PC)	\$ 529	\$ 459
★ 13" Color III, RGB, Commercial (Ap. II, III)	\$ 479	\$ 399
DVM, Color II or III to Apple II Interface	\$ 199	\$ 175
NEC, 12" Green, Model JB1201M	\$ 249	\$ 159
12" Color, Composite, Model JC1212M	\$ 450	\$ 349
PRINCETON, RGB Hi Res	\$ 795	\$ 599
QUADRAM, Quadcolor 12" RGB Color	\$ 395	\$ 325
QuadScreen 17", 968 x 512, 2 pages, w/cable, card, disk	\$ 1995	\$ 1595
SANYO, 9" Green, Model DM5109	\$ 200	\$ 139
12" Green, Model DM112CX	\$ 260	\$ 199
13" Color, Composite, Model DM6013	\$ 470	\$ 349
ZENITH, 12" Green, Model ZVM121	\$ 150	\$ 99

MODEMS AND ACCESSORIES

HAYES, Micromodem II (for the Apple II)	\$ 379	\$ 275
Apple Terminal Program for Micromodem II	\$ 100	\$ 65
IBM-PC Smartmodem II Software	\$ 119	\$ 89
Stock Chronograph (RS-232)	\$ 249	\$ 189
Smartmodem 300 (RS-232)	\$ 289	\$ 225
Smartmodem 1200 (RS-232)	\$ 699	\$ 535
IBM-PC Smartmodem 1000 Bplus Smartcom II	\$ 599	\$ 439
Micromodem 100 (S-1200)	\$ 399	\$ 275
IBM-PC to Modem Cable	\$ 39	\$ 29
NOVATION, Appletalk II Modem, 300 BAUD	\$ 389	\$ 269
212 Apple Cat, 1200 BAUD	\$ 725	\$ 599
SIGNALMAN, Modem MKII (RS-232)	\$ 99	\$ 79
SSM, Transcend I for Apple II Data Comm.	\$ 89	\$ 69
Modem Card for the Apple II	\$ 299	\$ 259
Transmodem 1200 (110,300,1200)	\$ 695	\$ 559

CORVUS

6 Meg Hard Disk, w/Interface	\$2095	\$1895
11 Meg Hard Disk, w/Interface	\$3195	\$2695
20 Meg Hard Disk, w/Interface	\$4195	\$3495
IBM-PC Interface (IBM DOS), Manual & Cable Kit	\$ 300	\$ 239
Minor built in for easy backup	\$ 790	\$ 595
Apple Interface, Manual & Cable Kit	\$ 300	\$ 239
Other interfaces, Omni-Net, Constellation, Mirror, Air/Fit Stock		

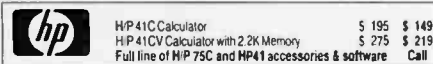

DISKETTES

CONTROL DATA CORPORATION Certified Top Quality Diskettes.		
CDC, 100 each, 5-1/4, with ring, SS, DD, 48T (Apple, IBM, etc.)	\$ 550	\$ 179
10 each, 5-1/4, with ring, SS, DD, 48T (Apple, IBM, etc.)	\$ 55	\$ 19
100 each, 5-1/4, with ring, DS, DD, 48T (IBM, H.P., etc.)	\$ 790	\$ 295
10 each, 5-1/4, with ring, DS, DD, 48T (IBM, H.P., etc.)	\$ 75	\$ 35
DYSAN, 10 each, 5-1/4, SS, SD, (Apple, etc.)	\$ 69	\$ 39
10 each, 5-1/4, DS, DD, 48T (IBM, H.P., etc.)	\$ 89	\$ 49
MAXELL, 10 each, 5-1/4, MD-1, SS, SD or SS, DD	\$ 55	\$ 29
GENERIC™ DISKETTES		
100 each SS, SD, 35 Track (Apple, Atari, etc.)	\$ 415	\$ 130
1000 each SS, SD, 35 Track (Apple, Atari, etc.)	\$4150	\$ 995
100 each DS, DD, 40 Track (IBM, H.P., etc.)	\$ 626	\$ 170
1000 each DS, DD, 40 Track (IBM, H.P., etc.)	\$6260	\$ 1400
★ With jackets, no labels, produced by a top of the line manufacturer. 90 day warranty by us		

PLOTTERS

ENTER COMPUTER, Sweet-P, with Apple interface and Software	\$ 795	\$ 695
--	--------	--------

★ Means a BEST buy **AD #980**

CASH & CARRY OUTLETS: Over-the-counter sales only. Open Monday through Saturday 10:00 until 5:00.
PORTLAND, OREGON, 11507-D S.W. Pacific Hwy, Terrace Shopping Center, Tigard, OR 97156 between 217 and I-5. Call 545-1020.
SEATTLE, WASH., Grand Opening Soon. Call for location (800) 547-1289.

Professionals T.M.

LOW PRICES TO PROFESSIONALS WHO KNOW WHAT THEY WANT AND KNOW HOW TO USE IT.™



apple II+/Ile supply center

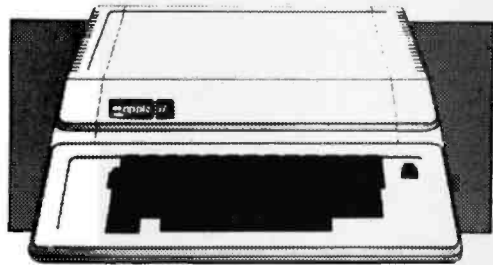

APPLE IIe 64K, 40 COLUMN	\$1,250
APPLE IIe 128K, 80 COLUMN	\$1,395
APPLE IIe, STARTER SYSTEM BY APPLE (System A)	
64K and 80 column	
Disk II with controller	
Apple Monitor III	
Monitor Stand	\$1,650
APPLE IIe STARTER SYSTEM BY CONROY-LA POINTE (SYSTEM B)	
128K and 80 column	
1 Micro-Si Drive with controller	
Filer, Utility and DOS 3.3 Diskette	
Sanyo 9" Green Monitor	
RF Modulator (for color TV)	
Game Paddles	
Game with color graphics and sound	
20 Blank Diskettes	\$1,695
WARRANTY: Limited warranty is 100% Parts & Labor for 90 days by us.	
To substitute or delete drive on System B, subtract \$245 and add drive price. (System D)	
To substitute or delete monitor on System B, subtract \$130 and add other monitor price (System M)	

DISK DRIVES for APPLE II+ /Ile

CENTRAL POINT, Filer, Utility and Apple DOS 3.3	\$ 20	\$ 15
μ-SCI		
A2, 5-1/4", 143K Disk Drive	\$ 479	\$ 249
Controller Card/A2 Drive	\$ 100	\$ 79
*A40, 160K, 40 Track Drive	\$ 449	\$ 299
*A70, 286K, 70 Track Drive	\$ 599	\$ 299
A40 A70 Controller Card	\$ 100	\$ 79
Rana		
Elite 1, 163K, 40 Tracks	\$ 379	\$ 265
Elite 2, 326K, 80 Tracks	\$ 649	\$ 415
Elite 3, 652K, 160 Tracks	\$ 849	\$ 525
Elite Controller w/ Manual & Diskette	\$ 145	\$ 84
TEAC		
*143K Disk Drive, 1/2 High Controller Card	\$ 379	\$ 279
*Electronics by ComX	\$ 89	\$ 69
VISTA		
Solo, 5 1/4" 143K Disk Drive Std. Height Controller Card	\$ 300	\$ 249
DiskPak V1200, 6MB Backup Sys.	\$1549	\$1049
*V1900 Dual 8", Std. Format w/Controller, Complete for Apple	\$2195	\$995

WHILE THEY LAST OVERSTOCK SPECIALS FOR APPLE III+ /Ile

*ALS, Synergizer + Supercalc + Condor (or II+)	\$ 749	\$299
*Axiom, 320K RAM Disk System (+ or e)	\$1000	\$685
*CCS, Serial Interface 7710A	\$ 150	\$ 99
*ComX, 16K RAM Card, 1Yr. Warranty, for II+	\$ 179	\$ 39
Microsoft, 16K RAM Card for II+	\$ 100	\$ 69
Satum Systems, 32K RAM Card for II+	\$ 249	\$169
64K RAM Card for II+	\$ 425	\$299
128K RAM Card for II+	\$ 599	\$399
Silicon Valley, Word Handler List Handler	\$ 250	\$ 39
*Vides, Videoterm, 80 column card for II+	\$ 345	\$229

IBM-PC/XT SPECIALS

\$45 \$40 Two or more.
64K CHIP KIT
9 Each, 4164, 200 ns. MEMORY EXPANSION
90 Day Warranty by us.

\$256 \$229 Two or more.
256K RAM BOARD
Fully Compatible, 2 Year Warranty by ComX.
With Fasttrak RAM/Disk Emulator and Spooler Software
Works on DOS 1.1 or 2.0.

CONTROL DATA

\$249 \$239 Two or more.
320K/360K DS DD DISK DRIVE
Same as now installed by IBM. With detailed installation instructions and 60 Day Warranty by Factory Authorized Distributor.

\$199
HALF HEIGHT
320K/360K DS DD DISK DRIVE
By CDC. With Detailed Installation Instructions
60 Day Warranty by Factory Authorized Distributor.

FOR ATARI
RANA 1000 Disk Drive, 320K **\$449** **\$369**

HARDWARE

RAM EXPANSION

	LIST PRICE	OUR PRICE
*ComX, for Ile, 80 col./64K Adder Card	\$ 295	\$145
*ComX, RAM Card, 1 Yr. Wty. (II+) 16K	\$ 179	\$ 39
*ALS, ADDRam (II+) 16K	\$ 100	\$ 59
*Microsoft, RAMCard (II+) 16K	\$ 100	\$ 69
*Satum Systems, RAM Card (II+) 32K	\$ 249	\$169
RAM Card (II+) 64K	\$ 425	\$299
RAM Card (II+) 128K	\$ 599	\$399
*Axiom RAM Disk System (+ or e) 320K	\$1000	\$685

VIDEO CARDS

*ALS, Smarterm II (+ or e)	\$ 179	\$139
ComX, 80 col./64K Adder (Ile)	\$ 295	\$145
Vides, Videoterm 80 col. (+ or e)	\$ 345	\$229
*UltraTerm (+ or e)	\$ 379	\$279
Soft Video Switch (II+)	\$ 35	\$ 25
Enhancer II (II+)	\$ 149	\$ 99
Function Strip (II+)	\$ 79	\$ 59
Full Video Line. Call. Up to 35% off.		
Vista, Vision 80	\$ 289	\$199

MISCELLANEOUS

ALS, The CP/M Card V3.0 (+ or e)	\$ 399	\$299
Z-Card (+ or e)	\$ 169	\$129
Color II (+ or e)	\$ 179	\$139
ASTAR, RF Modulator, to use TV	\$ 35	\$ 25
*CCS, Serial Interface 7710A	\$ 150	\$ 99
*Central Point, Alaska Card (copier, + or e)	\$ 130	\$ 99
Eastside, Wild Card (copier, + or e)	\$ 130	\$ 99
Kensington, System Saver	\$ 90	\$ 69
Key Tronic, KB200 keyboard (II+)	\$298	\$219
Kraft, Joystick (Ap III+)	\$ 65	\$ 49
Paddle (Ap III+)	\$ 50	\$ 39
M&R, Super Plan (+ or e)	\$ 50	\$ 39
*Microsoft, Z80 Softcard (+ or e)	\$ 345	\$235
Z80 Softcard Plus (+ or e)	\$ 645	\$459
Softcard Premium Pack (II+)	\$ 695	\$495
Softcard Premium Pack (Ile)	\$ 495	\$395
Micro Tek, Dumping 64, Buffer	\$ 349	\$269
*Orange Micro, Grappler Plus (e or +)	\$ 175	\$119
16K Buffer Board for Grappler +	\$ 175	\$119
Buffered Grappler +, 16K	\$ 245	\$185
2 Chip Kit for above for 64K	\$ 28	\$ 19
Paymar, Lower Case Chip (II+)	\$ 50	\$ 39
Practical Peripherals.		
MBP Ile 64K Par. (Epson Internal) (+/e)	\$ 279	\$209
MBS Ile 32K Ser. (Epson Internal) (+/e)	\$ 219	\$169
Microbuffer II +, 16K, (+ or e)	\$ 259	\$199
Par/Ser (specify)		
Microbuffer II +, 64K, (+ or e)	\$ 349	\$259
Par/Ser (specify)		
*PCPI, Appki-Card, 14 features 6 Mhz	\$ 375	\$275
RH Electronics, Super Fan II	\$ 75	\$ 59
*Satum Systems, Accelerator II	\$ 599	\$449
SSM A1011, Serial/Para Interface	\$ 225	\$169
TG Products, Game Paddles (II+)	\$ 40	\$ 29
Joystick (II+)	\$ 60	\$ 45
Select-A-Port (II+)	\$ 60	\$ 45
Trak Ball (II+)	\$ 65	\$ 44
Vides, PS/IO, Par/Ser Interface	\$ 229	\$169

SOFTWARE

BUSINESS

	LIST PRICE	OUR PRICE
Apple Computer, Inc. 50% off list, on Apple Inc. software	Call	Call
Applied Soft Tech., VersaForm	\$ 389	\$265
Artisal, MagicWindow II NEW!	\$ 150	\$ 99
Ashton-Tate, dBase II (Req CP/M 80)	\$ 700	\$395
Financial Planner (Req CP/M 80)	\$ 700	\$395
Friday (Requires CP/M 80)	\$ 295	\$199
User's Guide by Software Banc	\$ 30	\$ 20
BPI Systems, GL, AR, AP, PH or INV, each	\$ 395	\$295
Broderbund, Bank Street Writer	\$ 70	\$ 47
Continental, GL, AR, AP or PR ea	\$ 250	\$169
Home Accountant	\$ 75	\$ 49
FCM	\$ 100	\$ 68
Dow Jones, Market Analyzer	\$ 350	\$279
Market Manager	\$ 300	\$239
Hayden, Pie Writer (Specify 80 col. board)	\$ 150	\$ 99
Howard Soft, Real Estate Analyzer II	\$ 195	\$129
Tax Preparer	\$ 225	\$149
Info, Unim., Easywriter (PRO)	\$ 175	\$119
LJK, Letter Perfect w/ Mail Merge	\$ 150	\$ 99
*Micro Craft, (requires Z80 CP/M Card)	\$ 995	\$469
Professional Billkeeper	\$ 995	\$469
Vendict, (Legal Billing)	\$ 995	\$469
Micro Lab, Tax Manager	\$ 180	\$119
Micro Pro, (all require Z80-CP/M Card)		
WordStar [®] + Training Manual	SPECIAL \$ 495	\$239
MailMerge™	SPECIAL \$ 250	\$129
SpellStar™	SPECIAL \$ 250	\$129
* WordStar Professional, 4 Pak, 3 above + Star Index	SPECIAL \$ 895	\$429
* WordStar w/Applicard & CP/M	SPECIAL \$ 495	\$345
Microsoft, Multi-Plan (CP/M or Apple DOS)	\$ 275	\$199
Finajog, Multitool (CP/M or DOS)	\$ 100	\$ 75
Budget, Multitool (CP/M or DOS)	\$ 150	\$115
Sierra-On-Line, ScreenWriter II	\$ 150	\$ 89
The Dictionary	NEW! \$ 100	\$ 69
General Manager II	NEW! \$ 230	\$155
Osborne/C.P. Soft, (Disk and Book)		
Some Common Basic Programs (75 each)		
Statistics and Math Programs	\$ 100	\$ 49
Practical Basic Programs (40 each)	\$ 100	\$ 49
Peachtree, Requires CP/M & MBasic, 40 columns		
Series 40 GL & AR & AP, all 3	\$ 595	\$365
Series 40 Inv. or Payroll, each	\$ 400	\$275
Series 9 Text & Spell & Mail, all 3	\$ 595	\$395
Perfect, Perfect Writer	\$ 495	\$149
Perfect Speller	\$ 295	\$ 99
Perfect Writer/Speller 2 Pak	\$ 695	\$199
Perfect Filer	\$ 595	\$259
Quark, Word Juggler (Ile)	\$ 239	\$179
Sensible, Sens. Speller, specify 80 Col. Bnd.	\$ 125	\$ 85
* Silicon Valley, Word Handler	\$ 250	\$ 39
Joystick	\$ 90	\$ 35
* Sof./Sys., Executive Secretary	\$ 250	\$169
Executive Speller	\$ 75	\$ 55
Software Publishing, PFS: File (specify + or e)	\$ 125	\$ 85
PFS: Report	\$ 125	\$ 85
PFS: Graph	\$ 125	\$ 85

	LIST PRICE	OUR PRICE
Stoneware, DB Master	\$ 229	\$129
DB Utility for II	\$ 99	\$ 69
Vides, Applewriter II preboot disk	\$ 20	\$ 15
Viscalc 80 col. preboot disk	\$ 50	\$ 39
Viscalc 80 col. to 176K disk	\$ 90	\$ 69
Videoterm Utilities Disk	\$ 37	\$ 28
VistiCorp/Personal Software.		
Viscalc 3.3	\$ 250	\$169
Viscalc Enhanced (Ile) NEW!	\$ 250	\$169
VisiFile or VisiDex, each	\$ 250	\$169

UTILITY & DEVELOPMENT

Beagle, Utility City	\$ 30	\$ 22
DOS Boss	\$ 24	\$ 18
Apple Mechanic	\$ 30	\$ 22
Central Point, Filer, DOS 3.3 and Utility	\$ 20	\$ 15
Copy II Plus (bit copier)	\$ 40	\$ 35
Epson, Graphics Dump	\$ 15	\$ 9
Insoft, Graf-ORTH by Paul Lulus	\$ 75	\$ 59
Microsoft, A.L.D.S.	\$ 125	\$ 75
BASIC Compiler	\$ 395	\$299
Cobol 80	\$ 750	\$559
Fortran 80	\$ 195	\$149
TASC Compiler	\$ 175	\$159
* Omega, Locksmith (bit copier)	\$ 100	\$ 75
Penguin, Comp. Grphs. Sys. NEW!	\$ 70	\$ 53
Graphics Magician NEW!	\$ 60	\$ 41
Phoenix, Zoom Grafix	\$ 40	\$ 34
Quality, Bag of Tricks NEW!	\$ 40	\$ 29
Satum Systems, VC-Expand	\$ 100	\$ 49
VC-Expand 80	\$ 125	\$ 69
Sensible, Back it Up, (bit copier)	\$ 60	\$ 49

HOME & EDUCATION

Broderbund, Choptiter	\$ 35	\$ 26
BudgeCo, Pinball Constr. Set	\$ 40	\$ 27
Continental, Home Accountant	\$ 75	\$ 49
Dalamosi, Aztec or Zaxxon, each	\$ 40	\$ 27
Edu-Ware, (Large Inventory)	Call	Call
Hayden, Sargon II (Chess)	\$ 35	\$ 29
Infocom, Zork I, II, or III, or Starcross, each	\$ 40	\$ 27
Deadline	\$ 50	\$ 34
Lightning, Mastetype	\$ 40	\$ 27
Micro Lab, Miner 2049er	\$ 30	\$ 23
Muse, Castle Wolfenstein	\$ 30	\$ 23
Sierra-On-Line, Ultima II	\$ 60	\$ 40
Sorppan (X Rated)	\$ 35	\$ 22
Sir-Tech, Wizardry	\$ 50	\$ 39
Sub Logic, Flight Simul.	\$ 34	\$ 25
OTHER BRANDS AND PROGRAMS IN STOCK, CALL		

VISA

THE WORLD'S LARGEST COMPUTER MAIL ORDER FIRM T.M.

CONROY-LA POINTE

Formerly **Computer Exchange**

ALL MAIL: P.O. Box 23068, Portland, OR 97223
SHOWROOMS AT: 11507D SW PACIFIC HWY., PORTLAND, OR. OPEN M-SAT 10-5.
SEATTLE, WA OPEN M-SAT 10-5

NATIONAL ORDER DESK TOLL FREE (800) 547-1289

Order Desk Hours: 6AM to 6PM PST

Oregon TOLL FREE [800] 451-5151 Portland: 245-6200	Hot Line For Information On Your Order [503] 245-1030
---	---

Free Storage!



Buy Five...Get One Free!

Now there's a new cartridge manufacturer offering the only complete line of **total track tested** data cartridges for your 1/4" drive. Each cartridge is tested end to end...all tracks...to assure data integrity. As the world's leading manufacturer of 1/4" drives, DEI[®] knows the importance of cartridge requirements with today's higher bit

densities. Our **total track testing** gives DEI a decided edge in cartridge performance. To introduce you to the quality of DEI's 1/4" cartridge line, we're offering for a limited time, six cartridges for the price of five. To place your order, call 800-227-3800 extension 882. For dealer inquiries, call Danielle at (619) 452-7840 ext. 233.

DEI 1/4" cartridges are available in the following bit densities:

300' 1600 bpi/450' 1600 bpi/
450' 6400 bpi/555' 6400 bpi/
450' 10,000 fci

® Registered Trademark of Data Electronics, Inc.

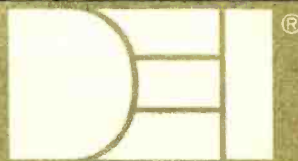

DATA ELECTRONICS, INC.

10150 SORRENTO VALLEY RD.
SAN DIEGO, CALIFORNIA 92121
TELEPHONE (619) 452-7840
TELEX 69-7118 · TWX 910-335-1150

The Unix Writer's Workbench Software

With this package, you can spot stylistic as well as grammatical problems in your prose

by Lorinda L. Cherry and Nina H. Macdonald

The Unix Writer's Workbench software, consisting of programs and databases, is designed to help improve your writing. The package includes programs that identify mistakes and stylistic problems in your draft text as well as interactive programs to help you answer spelling and word-choice questions. Because the programs are general, you can use them with a variety of texts from letters to journal articles. You can also adapt the programs to meet your own needs. This article describes programs you might use in writing and revising a paper and how you can tailor the Writer's Workbench software to your own writing.

Writing Help

Let's set the scene. You have just finished a huge program and can no longer avoid writing it up. You have a Unix operating system and are either composing your first draft at the terminal or writing it off line, planning to type it in later. You're using the standard Unix `mm` (memorandum) or `ms` (manuscript) macros for formatting. In one sentence, you use the word "seperate"—or should it be "separate"? The `spelltell` program can help you find out with its database of commonly misspelled words. If you can spell part of the word, the

program will return all the words on its list that match your entry. You type "sep.rate" or "~sep" or "rate\$" and get the correct spelling, "separate." (The period stands for any character, the caret for the beginning of the word, and the dollar sign for the end of the word.) Next you want to describe the "affect"—or should it be "effect"?—of your program on its input data. The `worduse` program and its database, with explanations of about 700 commonly confused or misused words, can set you straight.

Proofreading Help

You've finished the first draft, it's stored in a file, and you now face the dreaded task of proofreading and revising it. It's time to put the main Writer's Workbench program, `wwb`, to work. The `wwb` program has two sections, `proof` and `prose`, which may each be run separately; in fact, the Writer's Workbench system has a hierarchical structure, as shown in listing 1, and most of its smaller programs can be run independently. If you're a poor typist or speller, however, you should probably run `spell` on your paper before invoking `wwb`; the stylistic analysis part of `wwb` relies on the words in the text being spelled correctly.

`Proof` first checks spelling and gives

you a list of misspelled words (see listing 2). Next, it runs the punctuation checker, `punct`. The errors it finds include unbalanced quotation marks or parentheses, violations of the standard rules governing the order of punctuation marks, and sentences that do not begin with a capital letter. If you do not understand why the checker is complaining about your punctuation, type `punctrules` and get a display of the rules the `punct` program enforces.

`Proof` then checks the text for "double" words; that is, a word occurring twice in a row. This common mistake is easier for the computer than a human proofreader to find. `Proof` next gives the diction output, which displays sentences containing wordy or frequently misused phrases and recommends substitutions. Diction has a database of about 450 awkward or wordy phrases; each sentence in the text containing one of these phrases is printed with the unacceptable phrase set off in special marks (`*[` and `]*`). And sometimes, for the sake of efficiency, only part of the unacceptable phrase is bracketed. However, you should not assume the program is always right. `Proof` also looks for split infinitives. If you don't recognize split infinitives or don't know why you shouldn't use them, call `splitrules` to

get information.

Help with Prose

Perhaps the most important section of `wwb` output is `prose`, which analyzes your writing style by using a program that finds parts of speech. `Prose` gathers statistics, compares them with a standard you choose, and explains in English how the text might be improved. If your text compares favorably to the standards, `prose` will tell you so. If your text differs greatly from the standards, `prose` will suggest ways to improve it (see listing 3). The

program uses measures that writing experts agree lead to well-written text—varying sentence length and sentence type and avoiding the passive voice, for example.

With `wwb` output in hand, you'll probably want to start by making the changes suggested by `proofr`. These changes are fairly straightforward, but you will have to consider carefully the changes recommended in the section on word choice. It may be even harder for you to figure out how to follow the recommendations of `prose`. You can then run another pro-

gram, `style`, to find all sentences with certain characteristics. For example, you can ask `style` to print all sentences with passive verbs, nominalizations, expletives, or all sentences longer than 50 words. (See listing 3 for definitions.) This output should give you an idea of where to start. If you have too many passive verbs, try the `findbe` program, which provides a formatted draft of your text highlighting all forms of the verb "to be." Go through this draft and try to rewrite the highlighted verbs to lower your count. If there are many long words in your article, use `syl` to find them; give an integer to `syl`—5, for example—and it prints all the words in your article with five or more syllables.

Listing 1: A summary of the Unix Writer's Workbench system hierarchy.

COMMAND-FUNCTION TABLE

Commands	
<code>abst file</code>	evaluates text abstractness
<code>acro file</code>	finds acronyms
<code>findbe file</code>	identifies difficult syntax
<code>match stylefile1 2 N</code>	collates statistics from different texts
<code>org file</code>	shows text structure
<code>parts file</code>	assigns grammatical parts of speech
<code>sexist file</code>	finds sexist phrases and suggests changes
<code>spelltell pattern</code>	prints commonly misspelled words containing pattern
<code>style file</code>	summarizes stylistic features
<code>syl -n file</code>	prints words of n syllables or longer
<code>topic file</code>	provides clue to topic, keywords
<code>parts file</code>	assigns grammatical parts of speech
<code>wwb file</code>	runs proofreading and stylistic analysis
<code>proofr file</code>	gives proofreading comments
.....	finds split infinitives
<code>diction file</code>	finds awkward phrases and suggests changes
<code>double file</code>	detects repeated typings of words
<code>punct file</code>	checks punctuation
<code>spellwwb file</code>	checks spelling, using <code>spelldict</code>
<code>prose file</code>	gives extended editorial comments
<code>style file</code>	summarizes stylistic features
<code>parts file</code>	assigns grammatical parts of speech
Explanations	
<code>prosestand</code>	prints standards used by <code>prose</code> to evaluate documents
<code>punctrules</code>	explains punctuation rules
<code>splitrules</code>	explains split infinitives
<code>worduse word</code>	explains frequently misused or confused words
<code>wwbhelp word</code>	gives information about commands and functions
<code>wwbinfo</code>	prints a copy of this table
Environmental Tailoring	
<code>dictadd</code>	adds phrases to <code>ddict</code> , <code>spelldict</code> , <code>sexdict</code> dictionary
<code>spelladd</code>	adds words to <code>spelldict</code> dictionary
<code>mkstand</code>	builds standards for <code>prose</code> from user documents
User Specified Dictionaries	
<code>ddict</code>	personal list of awkward phrases
<code>sexdict</code>	personal list of sexist terms
<code>spelldict</code>	personal list of correct spellings

Note. Indented commands are automatically run by the less indented commands that immediately precede them.

Finishing Touches

The Writer's Workbench system contains several programs that let you look at text in different ways. The `org` program, for instance, prints all headings and the first and last sentences of each paragraph. If your text is well organized, the output of `org` should be reasonably coherent and can be used as a basis for a summary of the paper. If the output isn't coherent, you may have a serious problem. No program can tell you how to reorganize your paper; you'll have to decide how to present it to your readers. `Org` may help you see that you have problems, but it doesn't correct them.

Suppose you also wrote a short document to tell a user how to implement your program. Did you assume that your user was male or female? Many people resent such assumptions. A quick run of your documentation through the `sexist` program will ensure you won't make such a mistake. `Sexist` is simply a variant of the `diction` program with a different dictionary of phrases and substitutions.

If you need keywords for your paper, the `topic` program helps by printing the 20 most frequently used noun and adjective-noun pairs in the text. `Topic`'s output also gives you an idea of the subjects you've emphasized. A program called `acro` searches the text for acronyms, letting you

THE FORTH SOURCE™

MVP-FORTH

Stable - Transportable - Public Domain - Tools

You need two primary features in a software development package - a stable operating system and the ability to move programs easily and quickly to a variety of computers. MVP-FORTH gives you both these features and many extras. This public domain product includes an editor, FORTH assembler, tools, utilities and the vocabulary for the best selling book "Starting FORTH". The Programmer's Kit provides a complete FORTH for a number of computers. Other MVP-FORTH products will simplify the development of your applications.

MVP Books - A Series

- Volume 1, All about FORTH** by Haydon. MVP-FORTH glossary with cross references to fig-FORTH, Starting FORTH and FORTH-79 Standard. 2nd Ed. \$25
- Volume 2, MVP-FORTH Assembly Source Code.** Includes CP/M®, IBM-PC®, and APPLE® listing for kernel \$20

MVP-FORTH Software - A Transportable FORTH

- MVP-FORTH Programmer's Kit** including disk, documentation, Volumes 1 & 2 of MVP-FORTH Series (All About FORTH, 2nd Ed. & Assembly Source Code), and Starting FORTH. Specify CP/M, CP/M 86, CP/M+, APPLE, IBM PC, MS-DOS, Osborne, Kaypro, H89/Z89, Z100, TI-PC, MicroDecisions, Northstar, Compupro, Cromemco \$150
- MVP-FORTH Cross Compiler** for CP/M Programmer's Kit. Can also generate headerless code for ROM or target CPU \$300

- MVP-FORTH Meta Compiler** for CP/M Programmer's kit. Use for applications on CP/M based computer. Includes public domain source \$150
- MVP-FORTH Fast Floating Point** for APPLE Programmer's Kit. Includes 9511 math chip on board with disk and documentation. \$400
- MVP-FORTH Programming Aids** for CP/M, IBM or APPLE Programmer's Kit. Extremely useful tool for decompiling, calling, and translating. \$150
- MVP-FORTH** by ECS Software for IBM-PC or ATARI® 400/800. Standalone with screen editor. License required. Upgradeable \$100
- MVP-FORTH** by ECS Software for IBM-PC or ATARI 400/800. Enhanced with color animation, multitasking sound, utilities, and unlimited run time license. \$175
- MVP-FORTH Professional Application Development System (PADS)** for CP/M, IBM-PC, or APPLE. A three level integrated system with complete documentation. Complete system \$400
 - MVP-FORTH PADS** Enhanced virtual system \$150
 - MVP-FORTH PADS** Programming Aids \$150
 - MVP-FORTH PADS** Meta Compiler \$150

*** MVP-FORTH operates under a variety of CPU's, computers, and operating systems. CP/M® disks can be supplied 8", SS/SD, 3740 format or 5 1/4" for Osborne® Northstar® Micro Decisions® Kaypro® or H89/Z89®. Specify your computer and operating system. ***

FORTH DISKS

FORTH with editor, assembler, and manual.

- APPLE** by MM \$100
- APPLE** by Kuntze \$90
- ATARI** valFORTH \$60
- CP/M** by MM \$100
- HP-85** by Lange \$90
- HP-75** by Cassidy \$150
- IBM-PC** by LM \$100
- NOVA** by CCI 8" DS/DD \$150
- Z80** by LM \$50
- 8086/88** by LM \$100
- VIC FORTH** by HES. VIC20 cartridge \$60

Enhanced FORTH with: F-Floating Point, G-Graphics, T-Tutorial, S-Stand Alone, M-Math Chip Support, MT-Multi-Tasking, X-Other Extras. 79-FORTH-79.

- APPLE** by MM, F, G, & 79 \$140
- ATARI** by PNS, F, G, & X \$90
- CP/M** by MM, F & 79 \$140
- Apple, GraFORTH** by I \$75
- Multi-Tasking FORTH** by SL, CP/M, X & 79 \$395
- TRS-80/II or III** by MMS, F, X, & 79 \$130
- Timex** by FD, tape G, X, & 79 \$45
- TUTORIAL** by LH, includes Starting FORTH \$95
- Extensions** for LM Specify IBM, Z80, or 8086
 - Software Floating Point \$100
 - 8087 Support (IBM-PC or 8086) \$100
 - 9511 Support (Z80 or 8086) \$100
 - Color Graphics (IBM-PC) \$100
 - Data Base Management \$200
- Victor 9000** by DE, G, X \$150

fig-FORTH Programming Aids for decompiling, calling, and translating. CP/M, IBM-PC, Z80, or Apple \$150

CROSS COMPILERS Allow extending, modifying and compiling for speed and memory savings, can also produce ROMable code. *Requires FORTH disk.

- CP/M \$300
- 8086 \$300
- Northstar \$300
- IBM \$300
- Z80 \$300
- Apple II/II+ \$300
- FORTH Computer - Jupiter Ace** \$150
 - 16K RAM Pack \$50
 - 48K RAM Pack \$125
 - Par/Sec Interface \$100

Key to vendors:
 CCI Capstone Computing Inc.
 DE Dai-E Systems
 FD Forth Dimension
 I Insoft
 LH Laxen and Harris
 LM Laboratory Microsystems
 MM MicroMotion
 MMS Miller Microcomputer Services
 NS Nautilus Systems
 PNS Pink Noise Studio
 SL Shaw Labs

FORTH MANUALS, GUIDES & DOCUMENTS

- ALL ABOUT FORTH** by Haydon. See above. \$25
- FORTH Encyclopedia** by Derick & Baker. Programmer's manual to fig-FORTH with FORTH-79 references. Flow charted. 2nd Ed. \$25
- Understanding FORTH** by Reymann \$3
- FORTH Fundamentals, Vol. I** by McCabe \$16
- FORTH Fundamentals, Vol. II** by McCabe \$13
- Beginning FORTH** by Chirlian \$17
- FORTH Encyclopedia Pocket Guide** \$7
- And So FORTH** by Huang, A college level text. \$25
- FORTH Programming** by Scanlon \$17
- FORTH on the ATARI** by E. Floegel \$8
- Starting FORTH** by Brodie. Best instructional manual available. (soft cover) \$18 (hard cover) \$22
- Installation Manual for fig-FORTH** \$15
- 1980 FORML Proc.** \$25
- 1981 FORML Proc 2 Vol** \$40
- 1982 FORML Proc.** \$25
- 1981 Rochester FORTH Proc.** \$25
- 1982 Rochester FORTH Proc.** \$25
- 1983 Rochester FORTH Proc.** \$25
- A FORTH Primer** \$25
- Threaded Interpretive Languages** \$23
- META FORTH** by Cassidy \$30
- Systems Guide to fig-FORTH** \$25
- Invitation to FORTH** \$20
- PDP-11 User Man.** \$20
- FORTH-83 Standard** \$15
- FORTH-79 Standard** \$15
- FORTH-79 Standard Conversion** \$10
- NOVA fig-FORTH** by CCI Source Listing \$15
- NOVA** by CCI User's Manual includes editor, assembler, and utilities \$25

Source Listings of fig-FORTH, for specific CPU's and computers. The Installation Manual is required for implementation. Each \$15

- 1802
- 8080
- PACE
- 68000
- 6502
- 8086/88
- 6809
- Eclipse
- 6800
- 9900
- NOVA
- VAX
- AlphaMicro
- APPLE II
- PDP-11/LSI-11
- Z80

Ordering Information: Check, Money Order (payable to MOUNTAIN VIEW PRESS, INC.), VISA, MasterCard COD's \$5 extra. No billing or unpaid PO's. California residents add sales tax. Shipping costs in US included in price. Foreign orders, pay in US funds on US bank, include for handling and shipping by Air: \$5 for each item under \$25, \$10 for each item between \$25 and \$99 and \$20 for each item over \$100. Minimum order \$15. All prices and products subject to change or withdrawal without notice. Single system and/or single user license agreement required on some products.

DEALER & AUTHOR INQUIRIES INVITED

MOUNTAIN VIEW PRESS, INC.

PO BOX 4656

MOUNTAIN VIEW, CA 94040

(415) 961-4103

quickly check if you've defined them upon introduction.

Tailoring the System

Next, let's say you're finished with your paper and have submitted it for publication. The last time you ran *proofr*, however, it complained about the spelling of your last name and about that cute acronym you used to name your program. You can use *dic-tadd* to create your own supple-

mentary file that will be searched automatically next time you use the Writer's Workbench system. Some of the phrases *proofr* complains about are appropriate in context. Use *dictadd* and make a private file of phrases; in the future, *proofr* will ignore some of its own phrases and use yours instead. Using this supplementary file concept, you can adapt the output of the Writer's Workbench system to your own needs.

Suppose you decide the audience you usually address is much less sophisticated technically than readers of technical instructional manuals, and therefore you'd like different standards for prose. Or perhaps you have a favorite author whose style you would like to emulate. To adapt the software for such styles, you first have to gather text samples that reflect your standards. Because the Writer's Workbench system calculates statistics, you must have a reasonable number of samples on line—at least 20 samples of more than 2000 words each. Once you have the text in files, the *mkstand* (for "make standard") program will calculate all the statistics necessary for prose. Subsequently, when you run the program, you can have your text compared to your own standards rather than those of the system.

Listing 2: *The proofr program's output for a first draft of this article.*

```
***** SPELLING *****
Possible spelling errors in byte_draft are:

meta          sep.rate      SPELLTELL
misspeled     seperate     WORDCHOICE
scp

If any of these words are spelled correctly, later type
    spelladd word1 word2 ... wordn
to have them added to your spelldict file.

***** PUNCTUATION *****
The punctuation in byte_draft is first described.

0 double quotes and 18 single quotes
2 apostrophes
0 left parentheses and 1 right ones
Because of the unbalanced parentheses, the following check for mistakes
may make errors.

The program next prints any sentence that it thinks is
incorrectly punctuated and follows it by its correction.

line 3
OLD: you have just finished a super program and
NEW: You have just finished a super program and

For more information about punctuation rules, type:
    punctrules

***** DOUBLE WORDS *****
For file byte_draft:

the the appears beginning line 10 byte_draft

***** WORD CHOICE *****

Sentences with possibly wordy or misused phrases are listed next,
followed by suggested revisions.

For file byte_draft

beginning line 15 byte_draft
You *{ utiliz}*e the SPELLTELL program, an interactive program
with a data base of the most commonly misspelled words, to find
out.
```

Listing 2 continued on page 246

How It's All Done

The proofreading programs look at *all* the words in the text. The stylistic programs, on the other hand, separate the words in sentences from the words in headings and figures and tables. Those words should not be included in any counts of words in sentences, nor should they be included as part of any sentence. Writer's Workbench programs use embedded formatting commands to discard nonsentence text. Users of the Unix formatting macro packages label their nonsentence text with macros for headings, tables, centered lines, and other displays that are not part of the regular text. Thus, the stylistic programs can figure out which characters to include in their analyses. Word-processing systems in which a typist types as though on a typewriter do not allow this analysis, and the Writer's Workbench stylistic programs would be difficult to implement with such systems.

Conclusion

The programs we've described are not designed to do everything for a writer; rather, they remove some of the tedious burden of proofreading and provide guidelines about style. In this way, they free writers to examine their organization and content.



BEFORE YOU DAMAGE YOUR COMPUTER, PLUG IT IN RIGHT.

INTRODUCING THE WIRE TREE™ AC SURGE PROTECTOR, FROM NETWORKOR™.

Power surges and voltage spikes. Their causes can be as simple as someone opening your refrigerator, or running a power tool, or switching on a fluorescent light.

But their results can be devastating. They can wipe out your computer's memory. Even damage its sensitive circuits.

That's why smart computer users protect their personal computers by plugging them into The Wire Tree from Networkor.



The Wire Tree has four outlets and provides power surge protection that conforms to IEEE guidelines.

It comes with a bracket to mount underneath your desk or table and has a unique cable support feature which organizes your system's power cords into a neat bundle and moves them out of your way. And it lets you control system power from a single illuminated on/off switch.

You've invested a lot of time and money in your computer system. Protect that investment with The Wire Tree. Ask for one at your local computer store.

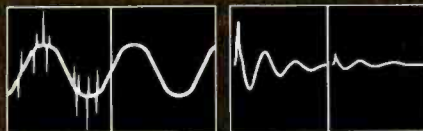

Voltage surge enters The Wire Tree.

Constant power output

R.F. interference enters The Wire Tree.

Filtered power output



Networkor, Brooklyn, N.Y. 11237 (212) 821-7555

Listing 2 continued:

beginning line 27 byte_draft
[Through the use of] WORDCHOICE you discover the difference.

beginning line 27 byte_draft
WORDCHOICE is also an interactive program and has a
[very] large data base of the commonly confused or misused
words.

file byte_draft: number of lines 29 number of phrases found 3

Please wait for the substitution phrases

----- Table of Substitutions -----

PHRASE	SUBSTITUTION
through the use of:	use "by, with" for " through the use of"
utiliz:	use "use" for " utilize"
very:	use "OMIT" for " very"
very:	use "doubtless, no doubt" for " there is very little doubt that"
very:	use "in a sense or OMIT WHOLE PHRASE" for " in a very real sense"
very:	use "unimportant" for " of very minor importance"

- * Not all the revisions will be appropriate for your document.
- * When there is more than one suggestion for just one bracketed word, you will have to choose the case that fits your use.
- * Capitalized words are instructions, not suggestions.
- * To find out more about each phrase, type "worduse phrase."

NOTE: If you want this program to look for additional phrases or to stop looking for some, for instance to stop flagging "impact," type the command dictadd.

May 19 17:08 1983 PROOFR OUTPUT FOR byte_draft Page 3

***** SPLIT INFINITIVES *****

For file byte_draft:

Possible split infinitives:
to now describe

For information on split infinitives type:
splitrules

Listing 3: The prose program provided these comments on a poorly written technical paper.

NOTE: Your document is being compared against standards derived from 30 technical memoranda, classified as good by managers in the research area of Bell Laboratories.

READABILITY

The Kincaid readability formula predicts that your text can be read by someone with 16 or more years of schooling, which is rather high for this type of document. Good technical papers average close to 13th grade level, even though the audience has more education than that.

This text includes many long words. Consider running the syllable counting program, _sy_, to look at the words in this text with five or more syllables. To do this type the following command when this program is done.

Listing 3 continued on page 248

The programs were designed hierarchically; casual users can get a lot of information with just one command, and experienced users can run individual programs when necessary.

The Writer's Workbench software has been very well received by writers who have used it. They report that they like getting information about their papers privately; only the computer knows. They prefer specific suggestions to comments such as "vague" or "poorly written" that they often get from human reviewers. Many claim their writing has improved simply because the system has prodded them to think about the choices they make when writing. ■

References

1. Cherry, L. L. and W. Vesterman. "Writing Tools—The STYLE and DICTION Programs." *Computing Science Technical Report*, 91, Bell Laboratories, 1981.
2. Cherry, L. L. "Writing Tools," *IEEE Transactions. Communications*, Special Issue on Communications in the Automated Office, 30, No. 1 (January 1982), pages 100–105.
3. Macdonald, N. H. "The Unix Writer's Workbench Software: Rationale and Design," *Bell System Technical Journal*, 62, No. 6, Part 3 (July-August 1983), pages 1891-1908.
4. Macdonald, N. H., L. T. Frase, P. S. Gingrich, and S. A. Keenan. "Writer's Workbench: Computer Aids for Text Analysis," *IEEE Transactions. Communications*, Special Issue on Communications in the Automated Office, 30, No. 1 (January 1982), pages 105–110.

Lorinda Cherry has a master's degree in computer science. She is a member of the technical staff of the Computing Science Research Center at Bell Laboratories (600 Mountain Ave., Murray Hill, NJ 07974).

Nina H. Macdonald holds a doctorate in linguistics from the University of Michigan and works at Bell Laboratories (6 Corporate Pl., Piscataway, NJ 08854).

Where to Learn More

To find out more about the Unix Writer's Workbench software that was announced at the July 1983 Usenix conference, contact
Western Electric Software
Sales and Marketing
POB 25000
Greensboro, NC 27420
(919) 697-6530

LOSE WAIT FAST™



Don't waste another second waiting for your printer to finish before you can use your computer again. With Microbuffer™ printer buffers you can print and process simultaneously!

MICROBUFFER.™
SO WHAT ARE YOU WAITING FOR?™

Another fine product from **PRACTICAL PERIPHERALS**

31245 La Baya Drive, Westlake Village, California 91362
(213) 991-8200 • TWX 910-336-5431

syl -5 filename

If most of the long words are technical terms that you must use, consider providing a glossary of terms to make this paper easier to read. If the words aren't technical terms, use shorter words wherever you can. In changing your text, be sure not to use several different words for the same concept; such synonyms are frequently confusing to the reader.

VARIATION

You have an appropriate distribution of sentence types.

SENTENCE STRUCTURE

Passives

This text contains a higher percentage of passive verbs (32.0%) than is common in good documents of this type (22%). A sentence is in the passive voice when its grammatical subject is the receiver of the action.

PASSIVE: The ball was hit by the boy.

When the doer of the action in a sentence is the subject, the sentence is in the active voice.

ACTIVE: The boy hit the ball.

The passive voice is sometimes needed

1. to emphasize the object of the sentence,
2. to vary the rhythm of the text, or
3. to avoid naming an unimportant actor.

EXAMPLE: The appropriations were approved.

Although passive sentences are sometimes needed, psychological research has shown that they are harder to comprehend than active sentences. Because of this you should transform as many of your passives to actives as possible. You can use the `style` program to find all your sentences with passive verbs in them, by typing the following command when this program is finished.

style -p filename

Nominalizations

You have appropriately limited your nominalizations (nouns made from verbs, e.g., "description").

Expletives

This text contains a higher percentage of expletives (8.0%) than is common in good documents of this type (3%). Expletives are words that have no content. For instance, "it" and "there" are often used as expletives in sentences such as "It is dark" and "There are three solutions to this puzzle." In these sentences, "it" and "there" have no content; they are simply linguistic placeholders.

Expletives are sometimes necessary, e.g., "It is raining." Often, however, they add unnecessary words to a sentence: "There are three solutions to this puzzle" can

easily be shortened to "This puzzle has three solutions."

To find all the expletives counted by this program, type the following command after this program is finished.

style -e filename

PROSE OUTPUTS

Options

You can request that your document be compared against different standards; typing `-t` with the `prose` command, e.g.,

prose -t filename

will compare your text against training documents.

A `-s` option will provide a very short version of the `prose` output.

prose -s filename

If you already have a style table in a file, you can save time by using it as the input to `prose` rather than the textfile. To do this, precede the style table filename with a `-f`, e.g.,

prose -f styletable-filename

All the options can be selected at the same time and listed in any order.

prose -f styletable-filename -s -t

Statistics

The table of statistics generated by the program `style` can be found in your file `styl.tmp`. If you want to look at it type:

cat styl.tmp

You can also use the `match` program, which provides a better format, type:

match styl.tmp

If you are not interested in the file, remove it by typing:

rm styl.tmp

ORGANIZATION

The `prose` program cannot check the content or organization of your text. One way to look at the overall structure of your text is to use `grep` to list all the headings that were specified for the `mm` formatter. To do this, type:

grep ".H" filename

You can also use the organization program, `org`, to look at the structure of your text. `Org` will format your paper with all the headings and paragraph divisions intact, but will only print the first and last sentence of each paragraph in your text so you can check your flow of ideas.

org filename

For people who want power.



And something more.



If you are seeking power in software we believe we have created the program you seek.

And our opinion is shared by a great many computer analysts who consider 1-2-3™ from Lotus® the most productive program in the marketplace.

Like many great ideas the essence of its success is its simplicity. With 1-2-3, you have spreadsheet, information management and graphic functions—all in one program.

You can switch from one function to another with the touch of a key, instantaneously. Although it seems faster.

In effect, it's a perfect combination of raw power and spectacular speed.

But for those who want more, 1-2-3 is specially designed so you can develop customized applications for your business needs. And the world's largest electronic spreadsheet has enough operators, functions and commands to perform virtually any task you ask of it.

In fact, the only limit is your imagination. 1-2-3 from Lotus is power and something more.

Call 1-800-343-5414 (In Massachusetts call 617-492-7870) and find out more about 1-2-3 from Lotus.

The hardest working software in the world.

Circle 275 on inquiry card.

1-2-3 and Lotus are trademarks of Lotus Development Corporation. All rights reserved.

INTRODUCING



THE SECOND GENERATION 96 TPI DISK

NO OTHER PRODUCT LINE IS EXPRESSLY DESIGNED FOR PRECISION 96 TPI PERFORMANCE.

What makes one computer a better buy than another?

How about a 96 tracks-per-inch drive? It can pack more than a megabyte on a single flexible disk.

Today, over 20 microcomputer manufacturers are marketing 96 TPI disk systems. And thanks to a new diskette engineered to standards previously unattainable, 96 TPI performance can now be as reliable as 48 TPI.

The product that makes this possible is the Xidex Precision™ Flexible Disk.

A TANGIBLY SUPERIOR DISK.

We had no choice. To turn out a highly reliable 96 TPI product line *in volume*, Xidex had to build the most automated and advanced disk manufacturing facility in the world. And we had to find ways to enhance current capabilities in materials, magnetic formulations, manufacturing and quality control.

The best substrate. We start with the most stable polyester substrate commercially available. We can command the best because we're the world's largest purchaser of polyester substrate. Using a superior substrate makes the disks less susceptible to distortions caused by temperature and humidity.

And that's just the beginning.

Tighter hub hole specs. We reduced the accepted tolerances on the center hole diameter by 50% (from .001" to .0005") to

decrease the risk of head to track misalignment.

Improved signal strength. We coat with a unique magnetic particle that has a signal level almost 20% higher than average. (This was accomplished without any sacrifice in overwrite and peak shift properties.) The resulting "hotter" signal means you're less likely to lose your data if head alignment is less than perfect.

Better finishing. We use proprietary binders and lubricants, and we polish the disk to a higher luster than you're used to seeing. This significantly improves signal performance and assures longer life for the disk drive heads.

More protective jacket. Jacket construction is particularly critical to 96 TPI performance. Xidex has selected a 10 mil jacket that is 33% thicker than the industry average. The jacket not only feels more substantial, it offers greater protection from contaminants, extended handling and extremes in temperature and humidity. Its superior squareness and flatness allow it to slip more easily into the drive and improves double sided head compliance. The all-polyester liner helps the disk to rotate more quietly and with less torque.

Tighter quality control. Product testing must also be a cut above accepted standards. Xidex disks not only go through the most rigorous 100% test procedures, they are also required to pass an additional outgoing quality check of 18 tests.

Xidex disks are 100% certified . . . to a higher level than any other product. But many users don't realize that "100% certified" simply means that the disks are certified against dropouts. Disks can fail for other reasons, too. It's only because Xidex controls *all three* critical areas—coating, physical construction and testing—that we can produce a reliable 96 TPI product.

Naturally, our disks also offer a lifetime warranty against manufacturing defects.

HIGH VOLUME PRODUCTION CAPACITY.

Xidex's monthly shipments of disks have been soaring since mid-1982. And we're just barely tapping our capability. Our new coating facility will be able to turn out over 150 million disks a year.

Our product line also includes a full line of 48 TPI disks that are superior to anything on the market. Available in 5¼" and 8" sizes, they are made to the same exacting standards as our 96 TPI products.

A WORLD LEADER IN PRECISION COATING.

As one of the largest manufacturers of computer media products, we've been perfecting the art of precision, high speed, volume coating onto polyester since 1969. In fact, we currently coat more polyester media products than all manufacturers of flexible disks combined.

We're also the first vertically integrated American manufacturer of flexible disks in over five years.

If you'd like more information on the most reliable 48 and 96 TPI disks that money can buy, give us a call. We also have a technical paper on 96 TPI disks that's yours for the asking.

Xidex Magnetics, P.O. Box 3418, Sunnyvale, CA 94088-3418. (415) 964-4652. In California call toll free (800) 672-1403. Outside California call (800) 538-1584.

PRECISION™ FLEXIBLE DISKS

Smith-Corona makes a successful printer even better. Introducing the TP-II.

When Smith-Corona® introduced the TP-I™ daisy wheel printer, it filled an important need. It gave home users and small businesses the opportunity to have high-quality letter-perfect printing at the lowest price to that time. No wonder it's been such a success!

Now, Smith-Corona improves upon that success. With the TP-II™ printer.

The TP-II has all the features of the TP-I. It's compatible with most microcomputers. It handles letter and legal sized paper. There's an optional tractor feed for handling fanfold paper.

Dual Interface

But the TP-II has some significant improvements, as well. It can interface with both serial and parallel computers. Which means you can upgrade your computer whenever you want without having to buy a new printer, too.

Letter-Quality Printing

The TP-II has the same excellent print quality as the finest office typewriters. There's



a choice of easy-to-change daisy wheels to give you a wide variety of print styles and languages. (At \$7.95 each, you can easily afford several.) There is a new ASCII 93-character printwheel with all the characters necessary to print out computer program listings, as well as printwheels in seven foreign languages.

Self-Testing

The Self-Test Switch lets you automatically print out a test pattern to check on the TP-II's operating condition. You can easily set DIP switches for baud, parity and character bit length. Plus it offers carriage return line feed, as well as a new 256 character buffer.

800 Number for Information

Add to all these features the fact that the TP-II is made in America by a company that has earned a reputation for reliability. A company that backs its printers (and everything else it makes!) with a national factory service network and an 800 number you can call if you have a problem.

So if you're in the market for a high-quality, low-cost daisy wheel printer, consider the one that's improved upon success. The Smith-Corona TP-II.

Please send me more information on the Smith-Corona TP-II daisy wheel printer.

Name _____

Address _____

City _____ State _____ Zip _____

Mail coupon to:
Smith-Corona, 65 Locust Avenue
New Canaan, CT 06840

Smith-Corona

B10

Smith-Corona is a trademark owned by SCM Corporation.

Typesetting on the Unix System

The formatting and typesetting system built around the troff program works reliably and can be learned in a day

by Bill Tuthill

The Unix text and formatting system, based on the troff (Typesetter RunOFF) program, is the mainstay of document preparation at Bell Laboratories as well as many universities and research institutions. Offered free of charge with any computer that runs Unix, troff (pronounced tea-roff) is a dependable system that is easy to learn. Studies have shown that Unix composition is about 2.5 times as fast as typewriter composition and costs a third less (see reference 5). The current facility provides special languages that make tables, equations, and bibliographies easy to specify and format. Without change, it can have the same text file line-printed, typewritten (perhaps with proportional spacing), and phototypeset for publication. In newer releases the typesetting system also provides languages for drawing diagrams within a document.

The troff program was written in PDP assembly language in 1973 by Joseph Ossanna. The nroff program (New RunOFF) was devised to drive typewriter terminals instead of a typesetter and shares source code with troff. Updated programs were rewritten in the C language around 1975 and evolved slowly but steadily until late 1977, when Ossanna was killed in an automobile accident. Because nobody else knew exactly how troff worked, its evolution came to a halt.

Offshoots of troff

Other programs later grew up around troff: tbl for producing complex tables, eqn for typesetting mathematical equations, and refer for handling bibliographic references. These programs are preprocessors for troff. That is, they look for appropriate areas of text and transform a high-level specification language into low-level typesetting codes. These codes are then passed from the preprocessors to troff using the Unix pipe

The original troff allowed for only four fonts and 15 point sizes; the new one permits 256 fonts and 128 point sizes.

mechanism. The functionality the preprocessors provide could never have been built into troff itself given the memory constraints of the time when troff was first used.

Another advantage of preprocessors is that existing ones can be changed, and new ones written, without modification of troff itself. Thus, the modularity provided by the Unix system allowed typesetting software to grow through accretion into the full, mature system it is today.

The first versions of troff produced typesetting code only for the Graphics Systems (later Wang) CAT/4. In late 1979 Brian Kernighan began rewriting troff to produce intermediate ASCII (American National Standard Code for Information Interchange) code, which could then, theoretically, be converted to binary codes for any typesetter. In 1982 this software was released to the public.

Educational source licenses cost \$300 per processor, and commercial source licenses sell for \$4000 per processor. Both are available only to Unix license holders. The distribution tape includes translating programs for the Mergenthaler Linotron 202, Compu-graphic 8400, and Autologic APS-5 phototypesetters and the Imagen Canon LBP-10 laser printer. Note, however, that recent releases of Unix, including 4.1 BSD and System V, do *not* include the new device-independent troff.

The original troff allowed for only four fonts and 15 point sizes; the new one permits 256 fonts and 128 point sizes. In addition, the former line-length limit of 7.54 inches has been lifted. The new troff also provides graphics primitives for drawing diagonal lines, circles, ellipses, arcs, and splines. Two new preprocessors, pic and ideal, provide a way to include diagrams in typeset documents. Pic is simpler and thus easier to learn, but ideal provides more powerful con-

structs for shading and opaquing. Unfortunately, neither program is as easy to use as Lisa Draw because they require that diagrams be specified linguistically rather than graphically.

The coding and design of *troff* are often criticized. It is true that its old C source code is largely un-commented, but it is also well organized and has proven extremely robust. The native input syntax is terse and unnatural, yet it is sufficiently general that macros at the user level are natural, mnemonic, and extensible. *Troff* is also criticized for its voracious appetite for computer resources, particularly when used in conjunction with the preprocessors. However, some typesetting systems are even worse. Let's face it: the computing required for text processing is inherently much greater than that required for numerical processing. Strings take up more space in memory than numbers; calculating character widths and filling and adjusting lines require a lot of number crunching.

Other Formatting Systems

Most formatting systems that run on mainframes are based on the *runoff* formatter written at MIT in the early 1960s. The idea behind that formatter was to mix text and formatting directives in the same file. Formatting commands appear on lines starting with a period, whereas text lines do not start with a period. With this type of formatter, which could be called a batch system, files are prepared with a text editor and then material is run off with a separate program. The *troff* program descended from *runoff* and uses the same arrangement to specify commands.

Today, most word processors that run on microcomputers are interactive—files are formatted while you are entering text, using one unified program. In many ways this arrangement works better than a batch formatting system, because you aren't surprised by unusual results when you run off a file for the first time. However, the theory that "what you see is what you get" also implies that "what you see is *all* you get." Word-

star, for example, does not provide proportional spacing on a daisy-wheel printer, let alone the ability to do phototypesetting, mathematical equations, and complex tables.

The *troff* system has two principal competitors: *TEX*, from Stanford University, and *Scribe* from Unilogic. (In addition, many commercial typesetting systems are available that do not compete directly because of their high cost and because they do not run on general-purpose computers.)

TEX was developed in 1978 by Donald Knuth at Stanford. Parts of it, especially its equation-formatting capability, were inspired by the *eqn* program on Unix. The strength of *TEX* lies in its algorithms for boxes,

Batch formatting may produce unusual results but offers more powerful options.

paragraphing, hyphenation, and "glue." *TEX* considers text objects (such as paragraphs and lists) to be boxes separated from each other by stretchable glue. Entire paragraphs are held in a data structure then output all at once to prevent orphans and widows. (An orphan is a *single* line from the beginning of a paragraph appearing at the bottom of a page, and a widow is a single line from the end of a paragraph appearing at the top of a page.) Hyphenation is avoided, if at all possible, simply by measuring how much room is left on the final line of a paragraph and placing extra words there. By contrast, *troff* works a line at a time. Therefore, widows and hyphenation problems occur every now and then, although orphans can easily be avoided.

The first version of *TEX* was written in *Sail*; newer versions are in a nonstandard version of *Pascal*. The principal drawbacks of *TEX* are that it is difficult to learn and use and poorly documented. Its input language is baroque and hard to read, and no useful beginner's manual is available—the one book by Knuth must suffice. In addition, many sym-

bols required by *TEX* are not available on standard ASCII keyboards. Tables are difficult to specify using *TEX*, no bibliographic tools are provided, and *TEX* has no graphics language. On the other hand, Knuth's *Metafont* provides a means of describing and creating entirely new symbols. Support for various output devices, both laser printers and typesetters, has improved. *TEX* was chosen by the American Mathematical Society as its standard document-formatting language. The American Physical Society chose *troff* as its standard language.

Arguably the easiest to use of all the batch formatting systems, *Scribe* was written in 1979 by Brian Reid at Carnegie-Mellon University and is now marketed by Unilogic Ltd. in Pittsburgh. Although not so much simpler to use that it can hold its own against interactive mouse-driven systems, the *Scribe* formatter does accommodate different types of documents (such as letters, articles, theses, books) and high-level text constructs (such as paragraphs, titles, and headers). Document types and text constructs are defined in an easily modified *Scribe* database. This system's beginner-level manual is excellent, as is the documentation for more advanced users.

Scribe has two principal drawbacks, however. Its licensing cost is relatively high, and the current version has no facility for producing mathematical equations, although such a feature is promised for future versions. Tables are fairly difficult to specify using *Scribe*, and it provides no graphics language.

Some users also complain that *Scribe* is verbose; when converting *Scribe* input to *troff* input, deletion is the most common operation required. However, *Scribe* support for different output devices is (and always has been) excellent. In addition to supporting typesetters that the new *troff* supports, and some that it doesn't, *Scribe* supports the Xerox 9700 laser printer.

Typesetting with troff

To use the *troff* system, you enter text and interspersed formatting commands (lines beginning with a

WATCH OUT ATARI! AT-D2 HAS LANDED!



AVAILABLE
NOW!
WITH PRINTER
PORT

...WITH IT'S FLEET OF THE MOST ADVANCED SINGLE AND DOUBLE DENSITY DRIVE SYSTEMS IN THE UNIVERSE - TOTALLY COMPATIBLE WITH ATARI* COMPUTER MODELS 400, 800, 600XL, 1200XL, 1400XL, AND 1450XL.

DOCK YOUR FAVORITE PRINTER DIRECTLY TO OUR DRIVE'S BUILT-IN PARALLEL PRINTER INTERFACE. THERE'S NO NEED TO BUY AN EXPENSIVE ATARI 850 MODULE.

THE COMMAND CONTROL PANEL FEATURES READ, WRITE AND DENSITY INDICATORS, A TRACK COUNTER TO LOCATE EVERY BIT OF YOUR DATA AND A TOUCH-SENSITIVE SWITCH TO PROTECT IT.

WARP SPEED OF UP TO 18 TIMES FASTER THAN ANY OTHER ATARI DRIVE IS ACHIEVED WITH OUR OPTIONAL TURBO-CHARGED SOFTWARE.

AWESOME POWER — DESTROY A PLANET OR LEARN HOW ONE IS CREATED. BALANCE YOUR CHECKBOOK OR WRITE A BESTSELLER. LEARN A NEW LANGUAGE OR CREATE ONE.

IT'S MAGNIFICENTLY SIMPLE! — JUST PLUG IT IN AND LIFT-OFF!

*Atari is a registered trademark of Atari, Inc.

TRAK GIVES YOU THE MOST STORAGE FOR YOUR DOLLAR!

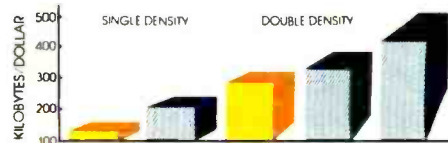

OUR FLAGSHIP, AT-D2, WITH TWICE THE STORAGE CAPACITY OF THE ATARI 810 DRIVE PLUS A PRINTER INTERFACE AND COMMAND CONTROL PANEL, HAS A VALUE OF OVER \$1000 YET COSTS LESS THAN \$500!

SEE YOUR DEALER NOW FOR A TEST FLIGHT, OR

call toll free: 1-800-323-4853
in Illinois, call collect: 1-312-968-1716
TWX 910-222-1848

trak  A commitment to quality
microcomputer corporation 1511 Ogden Ave., Downers Grove, IL 60515

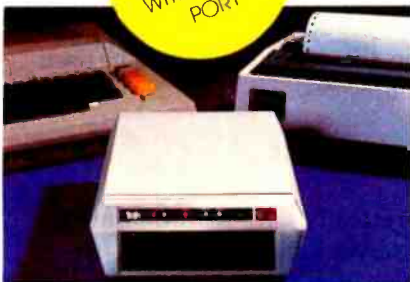

TRAK'S floppy and hard disk drive systems for the Apple and IBM-PC are available at many Computerland and other fine stores worldwide.

FOR INTER-COMPUTER DATA TRANSFER, YOU NEED "PORT AUTHORITY."

It's yours with the TLC-1: the three-port solid state data switch. Say good-bye, at last, to the inefficiencies and limitations of the electrical-contact switch. Thanks to the remarkable TLC-1: the solid state data switch with three independent RS232 ports. Repeat...three independent ports.

Because of this unique design, the TLC-1 resolves all configurations of switching among any three units... computers, modems and printers. This means 63 possible connection configurations - using any combination of DCE and DTE equipment - with all received and transmitted data independently switched. That's "port authority"!

And it's accomplished with very simple controls. Just three buttons and six status lights. You need no special software.

Moreover, because it processes every function with solid state switching, the TLC-1 participates in each connection while the power is on. So there's no switching noise, no junk data, no glitch of any kind. Just incomparable data transfer. And for \$245.00, that's an awful lot of power.

To order, or request more information, please write or call:



period) into a file using a text editor. Most people use vi (pronounced vee-eye and standing for visual), a screen editor developed at the University of California. Some installations prefer the Rand editor in one of its many incarnations (ned, red, ined, e) or some version of emacs, originally from MIT and the inspiration for MINCE and Perfect Writer. All these editors are screen oriented. Some diehards and underprivileged typists still use line editors such as ed, which makes them far less productive than they would be using a good screen editor.

When you are ready to run off the text, the file is written to disk and the nroff formatter is invoked:

`$ nroff -ms file`

A macro package (such as -ms) is almost always involved because it provides pagination and common text structures such as headers, paragraphs, footnotes, and displays. Here is a short list of the most frequently used -ms macros:

- .TL title
- .SH section header
- .PP paragraph
- .DS display start
- .DE display end
- .FS footnote start
- .FE footnote end

The nroff formatter provides typewriter output. If you want to typeset the file, this command would be used instead:

`$ troff -ms file`

Theoretically, it would not be necessary to change the file. However, lineation and pagination are different with troff because the typesetter packs more words per line and thus more words per page.

If the text had particularly tricky tables, you might want to employ the tbl preprocessor:

`$ tbl file | nroff -ms`

or

`$ tbl file | troff -ms`

Get everything done by Friday!™

Invoices. Paychecks. Mailing lists and form letters. Inventory. Reports. And just about any file handling that needs to be done around the office.

Get them all done quickly, efficiently and accurately any day of the week—by Friday!™



Friday! is the revolutionary new electronic file handling system for your microcomputer from Ashton-Tate, the people who invented dBASE II®. It's just \$295 (suggested retail price).

For the name of your nearest Friday! dealer, drop us a line. Ashton-Tate, 10150 West Jefferson Boulevard, Culver City, CA 90230. (213) 204-5570. **ASHTON-TATE**

dBASE II is a registered trademark and Friday! is a trademark of Ashton-Tate. ©Ashton-Tate 1983

The

HERBIE

Try-Before-You-Buy Special!

ALASKA
Compucenter
Anchorage, 907/561-2125

ARIZONA
Tab Products of Arizona
Phoenix, 602/864-0311

ARKANSAS
Parkin Printing & Stationery
Little Rock, 505/375-7231

CALIFORNIA
Beta Business Systems, Inc.
San Diego, 619/565-4505
Computer Paris Exchange
Northridge, 213/341-3783
Data Bits, Inc.
Orange County, 714/633-6650

Informco
Van Nuys, 213/994-3380

Int'l Memory Products of California
Santa Monica, 213/450-0132

Jeskin Products
San Diego, 714/489-0121

Kierulff Electronics, Inc.
Offices Nationwide
Los Angeles, 800/338-8811
213/725-2325 (in CA)

J. P. Patti, Inc.
Sante Fe Springs, 213/949-0961

Quest Media & Supplies, Inc.
Sacramento, 916/488-3310

The Supply Depot
Simi Valley, 805/583-0505

Tayco
Los Angeles, 213/466-5175

Todd Sales
Covina, 213/331-7377

COLORADO
Computerware, Inc.
Boulder, 303/443-0172

Data Pro, Ltd.
Denver, 303/777-8655

CONNECTICUT
Associated Computer Supplies, Inc.
Monroe, 203/261-6504

FLORIDA
AB Data Corporation
Tampa, 813/223-7194

Data Pax
Miami, 305/446-9291

Kar Printing
Hiialeah, 305/557-4782

National Data Products
Tampa, 800/237-3875

Pinellas Processing Supplies
Largo, 813/224-0466

GEORGIA
Computer Traders
Atlanta, 404/955-0360

Magnetic Media
Atlanta, 404/457-0002

HAWAII
Unitek Computer Services
Honolulu, 808/523-8881

IDAHO
R & L Data Systems, Inc.
Idaho Falls, 208/529-3785

ILLINOIS
American Computer Equipment Co.
Wheaton, 312/653-7444

Comark, Inc.
Elmhurst, 312/834-5000

Int'l Memory Products of Illinois
Prospect Heights, 312/537-8000

Pryor Corporation
Chicago, 312/644-5650

Thomas Computer Corporation
Chicago, 312/944-1401

Visible Computer Supply Corp.
St. Charles, 312/377-2586

INDIANA
Data Comm
Brownsburg, 317/852-5112

Kelley World Company
Mishawaka, 219/255-4926

IOWA
Nebraska Iowa Computer Supplies
West Des Moines, 515/225-2526

KANSAS
Mid-America Computing, Inc.
Lenexa, 913/492-8805

LOUISIANA
Byrd Business Forms
Kenner, 504/467-8400

MARYLAND
Federal Data Corporation
Chevy Chase, 301/986-0800

Grafico Corporation
Baltimore, 301/747-1065

MCO Computer Supplies
Millersville, 301/621-7800

Spartan Industries, Inc.
Burtonsville, 301/384-1300

MASSACHUSETTS
Continental Resources
Bedford, 617/275-0850
800/343-4688

MICHIGAN
J & B Data Processing Supplies
Kalamazoo, 800/422-0662

Precision Data Products
Grand Rapids, 616/452-3457

Transaction Storage Systems
Southfield, 800/FLOPPYS
800/265-4824 (Canada)

MINNESOTA
Allanson Business Products, Inc.
Bloomington, 612/881-1151

Computerware Data Products, Inc.
Eden Prairie, 612/941-6150

Sexton Data Products
Minneapolis, 612-941-5880

MISSOURI
Computime, Inc.
St. Louis, 314/434-5995

Specialty Computer Ribbons
Hazelwood, 314/731-0808

NEBRASKA
Nebraska Iowa Computer Supplies
Omaha, 402/551-1288

NEW JERSEY
Data Research Associates
Englewood, 201/569-2620

NEW MEXICO
I.M.S.
Albuquerque, 505/884-7591

NEW YORK
Arrow Electronics
Farmingdale, 516/694-6800

Corstar Business Computing Co., Inc.
White Plains, 914/428-5550

Daily Business Products, Inc.
Hauppauge, 516/543-6100

Datorex Systems, Inc.
Buffalo, 716/633-1031

NORTH CAROLINA
Clyde Rudd & Associates
Greensboro, 919/288-0222

Kester Business Systems
Greensboro, 919/855-1600

OHIO
Dak Supply Corporation
Cleveland, 216/238-0102

Treb-Kirby Company
Cleveland, 216/651-6282

Trebilo International, Inc.
Cleveland, 216/961-3334

OKLAHOMA
Data Products, Inc.
Oklahoma City, 405/943-9733

Tinker Office Supply
Tulsa, 918/622-8891

OREGON
Force 4 D. P. Supplies, Inc.
Portland, 503/620-8888

National Micro Wholesalers
Beaverton, 503/643-0626

PENNSYLVANIA
Computer Resources Co.
Allentown, 215/776-2100

Granville Associates, Inc.
Carnegie, 412/276-3588

National Ribbon, Inc. (NRI)
Morrisville, 215/736-1134

Used Computers, Inc.
Berwyn, 215/647-1881

RHODE ISLAND
Narragansett
Providence, 401/751-3440

TENNESSEE
Advance Magnetics, Inc.
Nashville, 615/329-0641

Forms and Supplies, Inc.
Memphis, 901/346-1249

TEXAS
Bull's I Data
San Antonio, 512/656-6367

Grammco Computer Sales
San Antonio, 512/690-0641

Monarch Paper Company
Houston, 713/686-9332

Philbo Enterprises, Inc.
Dallas, 214/358-1200

D. G. Renick & Company
Houston, 713/688-3604

Suntex Data Supplies
Houston, 713/783-5270

UTAH
Rebel Enterprises, Inc.
Salt Lake City, 801/261-3300

VIRGINIA
Champion Data Products, Inc.
St. Charles, 301/843-6980

Federal Sales Service, Inc.
Alexandria, 703/922-9400

Overview Systems
Falls Church, 703/241-9146

Virginia Impressions Products Co., Inc.
Richmond, 804/282-3166

WASHINGTON
Western Paper Company
Kent, 206/251-5300

Your business can sample the finest 5 1/4" double-sided floppies—with our compliments.

Control Data is the world's leading producer of disk drives and computer systems for American business. Our hardware and software are hard at work reducing costs, cutting lead time and boosting productivity throughout industry.

The same unbeatable quality that makes us a leader in computing also goes into our floppy disks. And now you can test our high quality, error-free performance at a price you really can't beat. Free.

How can you try before you buy our flexible media? Just fill out the attached coupon and mail it to us. Your local distributor will deliver your free 5 1/4" double-sided double-density floppy.

Find out for yourself. Fill out the attached coupon and mail it to Control Data Corporation today!

Offer limited to one redemption per business. Expires 12-31-83.



CD CONTROL DATA



```
(1a)
.vs 14
.TS
allbox;
cfB s s s s
c c c c c
l l n l l.
.sp
\s+2Northern California Whitewater\s-2
.sp
\fiRiver      Class   Length  Season  Comments\fp
Lower Klamath  2-3    25 mi.  summer  warm water and pleasant scenery
Cal Salmon    4-5    21 mi.  spring  extremely technical, many rocks
Yuba N Fork   3-4    9 mi.   spring  portage 10 ft. waterfall at end
American N Fork 4-5    13 mi.  spring  beautiful, several portages required
American Middle 3-4    17 mi.  summer  has tunnel through rock, 3 portages
American S Fork 2-3    18 mi.  summer  most popular whitewater section
Stanislaus    2-3    9 mi.   summer  inundated by New Melones Reservoir
Tuolumne     4-5    18 mi.  summer  continuously difficult and fast
Merced        3-4    14 mi.  spring  no dams above, very cold water
Carson E Fork 2       20 mi.  spring  scenic, includes hot springs
Truckee       1-3    25 mi.  spring  scenic, easy access, variety
.TE
```

(1b)

Northern California Whitewater				
<i>River</i>	<i>Class</i>	<i>Length</i>	<i>Season</i>	<i>Comments</i>
Lower Klamath	2-3	25 mi.	summer	warm water and pleasant scenery
Cal Salmon	4-5	21 mi.	spring	extremely technical, many rocks
Yuba N Fork	3-4	9 mi.	spring	portage 10 ft. waterfall at end
American N Fork	4-5	13 mi.	spring	beautiful, several portages required
American Middle	3-4	17 mi.	summer	has tunnel through rock, 3 portages
American S Fork	2-3	18 mi.	summer	most popular whitewater section
Stanislaus	2-3	9 mi.	summer	inundated by New Melones Reservoir
Tuolumne	4-5	18 mi.	summer	continuously difficult and fast
Merced	3-4	14 mi.	spring	no dams above, very cold water
Carson E Fork	2	20 mi.	spring	scenic, includes hot springs
Truckee	1-3	25 mi.	spring	scenic, easy access, variety

Figure 1: Through use of the tbl preprocessor, the input in 1a resulted in the attractive table shown in 1b.

Simple lists can be done by hand, but it's difficult to make them work properly on both a typewriter and a typesetter. If you fail to call the tbl program, junk will appear in place of a good-looking table. See figure 1 for an example of table input and output.

If the text contains mathematical equations, you will want to invoke the eqn preprocessor:

```
$ neqn file | nroff -ms
```

or

```
$ eqn file | troff -ms
```

The neqn variant is used for typewriters, while eqn is used with a typesetter. Both programs, developed by a compiler-compiler, translate a simple context-free grammar into appropriate formatting commands. See figure 2 for an example of equation input and output.

The refer preprocessor can be used to deal with bibliographic material. The pic and ideal languages provide for the inclusion of graphics into a

document. Tables of contents, as in figure 3, can be collected and generated automatically or produced as an afterthought.

Documentation Guide

The troff system is a well-documented one. The original manuals from Bell Laboratories are not suitable for beginners, however, because they are organized by program rather than in tutorial order and assume far too much knowledge on the part of the reader. Better material is available, though. For people with

COMPUTER WAREHOUSE

CALL TOLL FREE **1-800-528-1054**

PRINTERS

C-Itoh	
F-10-Parallel or Serial	\$1049
55 CPS Serial or Parallel	\$1555
8510 Parallel (Prowriter)	\$339
Computer International	
Daisywriter 2000 w/48K	Call
Comrex	
CR-1-S	\$665
CR-1-P	\$755
CR-2	\$449
Datasouth	
DS180	\$1155
Diablo	
620 RO	\$850
630 RO	\$1699
DTC	
380Z	\$1080
IDS	
Microprism 480	\$480
Prism 80	\$1160
Prism 80 Color	\$1345
Prism 132	\$1310
Prism 132 Color	\$1500
Juki	
6100	Call
Epson	
All models	Call
NEC	
PC-8023A	\$385
PC-8025	\$669
3510	\$1365
3550	\$1710
7710	\$1900
2010	\$785
2015	\$785
2050	\$910
Okidata	
82A	\$385
83A	\$630
84P	\$975
84S	\$1060
92	\$490
93	\$835
2350P	\$2020
2410P	\$2299
Olivetti	
PRAXIS 41 (w/interface)	\$725
2300 INK JET	\$399
Qume	
1140 w/interface	\$1369
Silver Reed	
EXP550P	\$675
EXP550S	\$690
EXP500	\$389
Star Micronics	
Gemini-10X	Call
Gemini-15X	Call
Delta	Call
Tally	
MT 160L w/Tractors	Call
MT 180L w/Tractors	Call
Spirit 80	Call
Toshiba	
P1350	\$1445
Transtar	
120P	\$449
120S	\$429
130P	\$669
130S	\$709
140S	\$1179
T315	\$449

Rana	
Elite 1	\$245
Elite 2	\$380
Elite 3	\$490
Controller (w/Drive only)	\$75
1000 (For Atari)	\$290

TRAK	
PI-1	\$199
ATD-2	\$375

SPECIAL OF THE MONTH

\$1375

**UNBELIEVABLE SYSTEM!
UNBELIEVABLE PRICE!**



**PIED PIPER • GEMINI 10X
TAXAN 12" AMBER MONITOR
5 SOFTWARE PACKAGES**

System includes: Pied Piper Portable (features below) • Gemini 10X
• Taxan KG-12N • CPM • Perfect Writer • Perfect Speller • Perfect Calc
• Perfect Filer • All necessary cabling.

VIDEO TERMINALS

ADDS	
A-1 Green	\$495
VIEWPOINT 60	\$685
Hazeltine	
Esprit I	\$485
Esprit II	\$540
Esprit III	\$735
Qume	
QVT 102 Green	\$535
QVT 102 Amber	\$550
QVT 103 Green	\$840
QVT 103 Amber	\$850
Televideo	
910	\$465
910+	\$549
925	\$699
950	\$899
970	\$975
Wyse	
Wyse 100	\$680
Wyse 300	\$1020
Visual	
Visual 50 Green	\$599
Zenith	
Z-29	\$635

MONITORS

Amdek	
Video 300	\$130
Video 300A	\$145
Color I	\$270
Color I Plus	\$275
Color II	\$450
Color III	\$360
BMC	
12" Green	\$85
12" Color	\$195
NEC	
JB 1201	\$155
JB 1260	\$115
Taxan	
12" Amber	\$125
USI	
12" Amber	\$150
Zenith	
12" Green Screen	\$95
12" Amber Screen	\$120

DISKETTES

Maxell	
MD-1 (Qty. 100)	\$230
Scotch	
744-0 (Qty. 100)	\$200
Elephant	
S/S S/D (Qty. 100)	\$155
COMPUTERS	
Altos	
Series 5-15D	\$2100
5-80-10 W/MPM	\$3525
Atari	
600XL	\$149
800XL	\$248
Corona	Call
NEC	
APC HO1	\$1875
APC HO2	\$2375
APC HO3	\$2875
Northstar	
Advantage	\$2160
Advantage w/5MB	\$3345
Advantage w/15MB	\$4315
Horizon II 64K QD	\$2625

Pied Piper

Communicator I Portable, Z-80, 64K Ram, Full sized keyboard, Slimline 5 1/4 Disk Drive with 1M Byte of storage, Monitor output, Perfect Word, Perfect Calc, Perfect Speller, Perfect Filer, CPM, 90-day nationwide warranty \$965

Sanyo	
MBC-550	\$749
MBC-555	\$1059
Televideo Systems	
802H	\$4210
803	Call
Teletote	Call
MODEMS	
Hayes	
Smartmodem	\$199
Smartmodem 1200	\$485
Smartmodem 1200B	\$430
Micromodem II	\$265
Above w/terminal program	\$299
Novation	
J-CAT	\$90



2222 E. Indian School Rd.
Phoenix, Arizona 85016

Order Line: 1-800-528-1054
Other Information: 602-954-6109

Order Line Hours: Mon.-Fri. 10-5 MST Saturday 9-1 MST

Prices reflect 3% to 5% cash discount. Product shipped in factory cartons with manufacturer's warranty. Please add \$8.00 per order for shipping. Prices & availability subject to change without notice. Send cashier's check or money order...all other checks will delay shipping two weeks.

FLIP-IT
works!
bookmark by D/Punch™

running out of diskettes?
how many floppies do you have?
only listen to records on one side?
only play tapes on one side?

STOP WASTING HALF YOUR MONEY & MEMORY EXACTLY.

Why should your single-sided diskettes be readable and writeable only to one side? THESE TIMES DEMAND THAT EVERY DOLLAR YOU SPEND HAVE THE POWER OF TWO

GREAT FOR:

1. Saving storage space
2. Increasing memory
3. Making backup copies
4. Saving money
5. Fun to do

Now you can easily convert your single-sided Floppies into Flippies (diskettes) using FLIP-IT's pat. pend., clumsyproof, leeryproof, conversion Kits. Works with single, double or quad density — hard or soft sector. With FLIP-IT, there is:

8" FLIP-IT

NO NEED TO:

1. Measure.
2. Make alignment marks.
3. Take media out of jacket.
4. Alter your hardware.
5. Buy additional software.

"FLIP-IT was very easy to use... converted... four boxes of diskettes in less than one half hour... Used other side... No Problems."
John DeMeritt, Belmont, MA

"No errors in reading or writing data in spite of heavy use... will continue to recommend to my friends and clients."
Joseph Wellelette, Brookline, MA

When ordering, remember to specify your computer system.

a) 5 1/4" FLIP-IT: for all 5 1/4" computers incl. Apple, IBM, Osborne, Atari, Radio Shack, Commodore, Victor, Kaypro, Franklin & more only \$29.95

b) 8" FLIP-IT: for 8" computers incl. IBM, Wang, Altos, Radio Shack, DEC, DG & more only \$34.95

c) Labels: (self-sticking, 100 ea.) only \$3.00

d) Write Protect/Enable Tabs: (100 ea.) \$2.65

e) Hub-Reinforcer Kit: (positioning tool for hub-opening)
5 1/4" disks: \$10.99 8" disks: \$12.99

f) Hub-Reinforcer Rings: (50 rings ea. for hub-opening)
5 1/4" disks: \$5.85 8" disks: \$7.20

g) Disk Sleeves: (Lint free, 10 ea.)
5 1/4" disks: \$2.55 8" disks: \$3.85

Add \$3 for shp & hdg (AK, HI, PR, Canada add \$5.50, Foreign countries add USD 10.50) — Mass. Res. add 5% tax. Send Check, Money Order to.

D/Punch Co. (BB)
P.O. Box 201, Newton Hds, MA 02161
Telex: 4991009 CHTRI TECH. INFO: (617) 964-2126

TOLL FREE 24 HRS ORDER LINE
1-800-227-3800 ext. 128

copyright 1983 D/Punch Corp.
We acknowledge all trademarks
Dealer inquiries invited.

For your FREE bookmark for your manuals, send us a stamped, self-addressed envelope. **SPECIAL**

FLIP-IT
works!
bookmark by D/Punch™

(2a)

```
.EQ
gsize 12
alpha over {2 pi} int from 1 to omega ~
left { sum from k=1 to inf sin sup 2 X sub k (t) right }
left [ f(t) + g(t) right ] cdot sqrt {lambda over phi}
.EN
```

(2b)

$$\frac{\alpha}{2\pi} \int_1^{\omega} \left\{ \sum_{k=1}^{\infty} \sin^2 X_k(t) \right\} [f(t) + g(t)] \cdot \sqrt{\frac{\lambda}{\phi}}$$

Figure 2: Example of input (2a) and the resulting equation (2b) set using the eqn preprocessor.

Table of Contents

Introduction	1
The Unix System	2
The Terminal	5
Tutorial Session 1	
Logging In and Logging Out	6
Using the Shell	9
Tutorial Session 2	
Using the Editor	11
Writing to Disk	14
Tutorial Session 3	
The Shell Revisited	15
Changing Your Password	17
Sending and Receiving Mail	18
Tutorial Session 4	
The Editor Revisited	19
Address Arithmetic, Pattern Searching	20
Tutorial Session 5	
Elementary Text Formatting	23
To Format or Not to Format	24
Formatting Larger Documents	26
Tutorial Session 6	
The Shell Revisited Again	30
Input/Output Redirection	31
Filename Expansion	32
Spelling and Syntax Checkers	33
Tutorial Session 7	
The Editor Revisited Again	34
Preserving and Recovering Files	37
Appendix 1: Directories	A-1
Appendix 2: Login Files	A-5
Appendix 3: The Unix Network	A-8
Appendix 4: Permissions	A-9
Appendix 5: Shell Scripts	A-11
Appendix 6: Setting Search Paths	A-12
Appendix 7: Miscellaneous Shell Metacharacters	A-14

Figure 3: Information for a contents page like this one can be gathered and generated automatically or collected later in the production cycle.

PRINTERS

C. ITOH

Prowriter

120 cps, 4 fonts (includes proportional), 8 sizes, 160 x 144 dpi, friction & tractor feed. A worthy rival of Epson.

Prowriter **\$399.88**
Prowriter 2 **\$719.88**

Starwriter



Letter-quality, 40 cps, 136 columns (Diablo 630 code). The **Printmaster** is the 55 cps version. Serial or parallel interface.

Starwriter **\$1219.88**
Printmaster **\$1679.88**

EPSON

FX, RX & MX



RX-80 **\$399.88**
MX-80 F/T **\$469.88**
MX-100 **\$664.88**
FX-80 **\$564.88**
FX-100 **\$769.88**

INFORUNNER

Riteman

A compact printer with 120 cps, 10/17 cpi, 160 x 144 dpi graphics, optional tractor (pin/friction std.). Very portable.

Parallel **\$349.88**

NEC

SpinWriter

2010/2030 **\$999.88**
2050 **\$1149.88**
3510/3530 **\$1729.88**
3550 **\$1999.88**
7710/7730 **\$2399.88**

OKIDATA

Microline Series

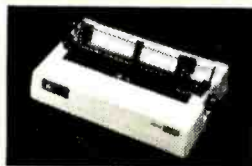

Microline 80 **\$339.88**
Microline 82A **\$419.88**
ML82A-ML92 Adjustable Tractor Feed **\$59.88**
82A/83A Okigraph I (graphics ROM) **\$49.88**
82A/83A Hi-speed RS-232C Interface **\$129.88**
Microline 83A **\$679.88**

Smith-Corona Memory Correct III Messenger \$629.88 UPS DELIVERED

Here's the printer you've been waiting for. The Smith-Corona **Memory Correct III Messenger** is ideal for the home or small office. It combines the features of an electric typewriter **and** a letter-quality printer. And it's designed to handle both jobs easily.

Features 12 cps, 3 pitches (10, 12 & 15), variable line spacing, 10.5" writing line, backspacing & auto-correction. Comes complete with parallel/serial printer interface.

Memory Correct III Messenger **\$629.88**



OKIDATA

Microline 92 **\$524.88**
w/RS-232C **\$634.88**
Microline 93 **\$884.88**
w/RS-232C **\$994.88**
IBM PC Plug-n-Play Graphics ROM (92/93) **\$49.88**
92/93A Hi-speed RS-232C Interface **\$99.88**
Microline 84 **\$1024.88**
w/RS-232C **\$1124.88**

MANNESMANN TALLY

MT-160 L



160 cps, 8 fonts (including a correspondence font), parallel & serial interfaces, friction/tractor feed, plus a menu-driven installation from the control panel.
MT-160 L **\$689.88**
MT-180 L **\$CALL**
MT-Spirit **\$CALL**

SMITH CORONA

TP-1/TP-2

TP-1 **\$CALL**
TP-2 **\$CALL**

SILVER REED

EXP-550



The **EXP-550** features 17 cps, 13/12/15 pitch capability, Diablo code compatibility. An exceptional printer.
EXP-550 (Parallel) **\$719.88**
w/RS-232C **\$759.88**
EXP-500 (Parallel) **\$459.88**

STAR MICRONICS

Gemini 10X/15



Gemini 10X **\$329.88**
w/RS-232C **\$429.88**
Gemini 15 **\$499.88**
w/RS-232C **\$589.88**
Delta 10 **\$CALL**

USI

Pi Monitors

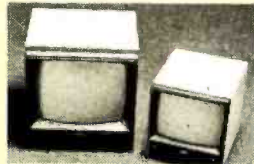

Pi 3 (12" amber) **\$189.88**
Pi 4 (9" amber) **\$159.88**

AMDEK/NEC

Monitors

300A **\$159.88**
300G **\$149.88**
JB-1205M (amber) **\$179.88**
JC-1203 (Hi-Res) **\$639.88**

QUADRAM

QuadChrome

690 x 240 resolution, 80 columns x 24 lines, 16 colors & exceptional performance. Cable included.
QuadChrome(RGB) **\$529.88**

PRINCETON GRAPHICS

HX-12

Same spec's as the **QuadChrome**. Same price too.
PGS HX-12 (RGB) **\$529.88**

US ROBOTICS

Password



0-300/1200 baud direct-connect modem with auto-dial/answer, full/half duplex, voice/data. Uses LSI technology. Cables & power supply included (specify computer).
Password **\$379.88**

US ROBOTICS

Courier (OS-1)

For the **Osborne-1**. 0-300/1200 baud direct-connect modem with auto dial/answer, full/half duplex, voice/data. Uses Osborne-1 modem port & includes cables, power supply & Telepac communications software for the Osborne-1.
Courier **\$479.88**

DC HAYES

Smartmodem

0-300 or 0-300/1200 baud direct-connect modems with auto dial/answer, full/half duplex. Stand-alone units come with power supply & modular cable (RS-232C cable optional).
1200B is an in-board modem for the **IBM-PC** & includes **Smartcom II**.
300 **\$219.88**
1200 **\$539.88**
1200B w/Smartcom II (IBM PC) **\$459.88**

NOVATION

SmartCat
(300 baud) **\$199.88**
(1200 baud) **\$499.88**
Apple Cat II
(300 baud) **\$319.88**
(1200 baud) **\$669.76**

Cat
D-Cat (300 baud) **\$159.88**
J-Cat (300 baud) **\$139.88**

IBM Peripherals



We carry a variety of IBM PC peripherals, including Quadram's **Quadboards**, **Quadlink** & the single-function boards, **AST's Sixpak**, **MegaPlus**, **MegaPak, I/O+**, Tandon's **TM-100-2** double-sided drives, **QCS's Big Blue & Hard Disk** subsystems, plus **Maynard Disk Controllers** in a variety of configurations.
Call **(800) 343-0726** for prices & orders.

Apple Peripherals

We also carry numerous Apple II/III/IIe peripherals, including **Pkaso Printer Cards**, **Microsoft's Z80 Cards, RamCards & Premium Packs**, **Vindex's VideoTerm & Enhancer II**, **Rana Elite-1 Disk Drives**, **Saturn Systems Accelerator II & Memory Boards**, **Quadram's eRAM 80 Column Card**, & **Kensington's System Saver & Format II**. We also carry the **Ace 1000** from Franklin Computers.
Call **(800) 343-0726** for prices & orders.

Accessories

We also carry cables, diskettes, diskette boxes, switch boxes, surge protectors & printer paper.
Call **(800) 343-0726** for prices & orders.

Information/Orders:

(603) 881-9855

Orders Only:

(800) 343-0726

No Hidden Charges:

We pay UPS ground shipping on all our orders, and we *never* charge extra for credit cards. We accept CODs up to \$1000 & add a \$10 fee per order. We have a \$50 minimum order. Personal checks are cleared in 3 weeks.

All our equipment is shipped with full manufacturer's warranty. We sell only what we are authorized to sell to insure full warranty support, & we're authorized for warranty work on a number of printers. We also offer extended warranty plans for many printers.

Sorry, we cannot accept open POs or extend credit/terms at these prices. APO and foreign orders are not accepted.

We prepared this ad in August, & prices do change, so call to verify them.



HIGH TECHNOLOGY AT AFFORDABLE PRICES THE BOTTOM LINE



MILFORD, NH 03055-0423 □ TELEPHONE (603) 881-9855

Circle 69 on inquiry card.

www.americanradiohistory.com

no previous computer experience, one book teaches editing and formatting in about eight hours. *The Unix Tutorial* by Peter Birns, Pat Brown, and John Muster (UC Berkeley, 1983, to be published by Prentice-Hall late this year as *Unix for People*) starts with the vi screen editor, as is appropriate, rather than with an outmoded line editor such as ed or ex.

For those interested in learning all the facets of Unix, rather than merely document preparation, *Introducing the Unix System* by Henry McGilton

and Rachel Morgan (McGraw-Hill, 1983) is a clear but detailed book that includes several chapters on the various editors and formatting tools. It is so good that it is unlikely to be superseded. The System V Unix release from AT&T includes a new guide to document preparation. Unfortunately, like most of the new documentation from Western Electric, this guide adds more paper to the stack of Unix manuals—but little functionality. It is hard to use this book, and the text is often lifted ver-

batim from material available elsewhere. Consult the books listed in the references list at the end of this article for more on the Unix formatting and typesetting system.

But realize that by the time a software system is as mature, reliable, and well documented as troff is, it is already outmoded. Anybody who has thought seriously about troff will tell you that someone should write a better formatting and typesetting system. Such a system would provide interactive previewing on a bit-map display, the capability of incorporating pictures and graphs within a document, and a simple icon-oriented user interface. Of course, those people never volunteer to write this system themselves, nor do they offer to pay for the years of labor required to carry out such a project. Until a better system is developed, users can try some of the sophisticated Unix-based systems, such as the Bedford system, that are already on the market. Those alternatives, however, are very expensive. ■

TSL's new Hard Disk Drive FALCON stores 30 MILLION BYTES

Formatted

and

- * installs in minutes on your IBM-PC
- * can be configured to run either under DOS 1.1 or DOS 2.0
- * the disk controller uses error correcting algorithms for maximum reliability.
- * uses high quality CDC WREN hard disk for storage.

TSL's FALCON stores *ninety times* as much data as your PC double-sided floppy disks.

TSL's INTRODUCTORY PRICE

\$3995⁰⁰ limited
time
offer

includes a full
90 day warranty.

To order your FALCON at this price or to find out if FALCON interfaces with your PC, call (314) 343-9140 or write:

FALCON
TSL
Dept. 10-83B
306 Axminster Drive
Fenton, MO 63026
Dealer inquiries invited

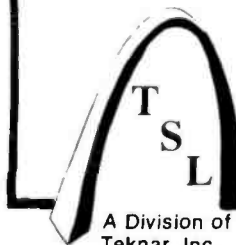

A Division of
Teknar, Inc.

Always a step ahead.

References

1. Joy, Bill and Mark Horton. "An Introduction to Display Editing with Vi." *VAX Unix Programmer's Manual*, Vol. 2c, University of California, Berkeley, 1980.
2. Kernighan, Brian W. and Lorinda L. Cherry. "Typesetting Mathematics—User's Guide." *Unix Programmer's Manual*, Vol. 2a, Bell Laboratories, 1979.
3. Knuth, Donald. *TEX and Metafont: New Directions in Typesetting*. Bedford, MA: Digital Press, 1979.
4. Lesk, M. E. "Tbl—A Program to Format Tables." *Unix Programmer's Manual*, Vol. 2a, Bell Laboratories, 1979.
5. Lesk, M. E. and Brian W. Kernighan. "Computer Typesetting of Technical Journals on Unix." *Proceedings of the National Computer Conference*, Vol. 46, 1977, pages 879-888.
6. Reid, Brian K. and Janet H. Walker. *Scribe Introductory User's Manual*. Pittsburgh, PA: Unilogic Ltd., 1980.
7. Saltzer, J. E. "Runoff. *The Compatible Time-Sharing System*, edited by P. A. Crisman. Cambridge, MA: MIT Press, 1965.
8. Western Electric. *Document Processing Guide: Unix System*. 1982.

Bill Tuthill is a programmer at Imagen Corp. (2660 Marine Way, Mountain View, CA 94043). He has a bachelor's degree from Middlebury College and a master's degree from the University of California, Berkeley. His interests include music and outdoor sports.

MAXI PROGRAMMING FOR MICRO-COMPUTERS



Let ALCOR Language Systems Transform You Into a Professional Programmer

ALCOR languages can guide you step-by-step from novice programmer to a seasoned professional. All of our systems are easy to use and share a clean, simple interface. In fact, all systems require only two commands to compile and execute a program!

Are You Tired Of Struggling With The Documentation?

No longer will you have to fumble through poorly written manuals filled with a peculiar dialect of progamese. Each of our languages come with a complete and well organized documentation set that includes a special language tutorial for new programmers.

Never again will you have to figure out whether a problem is a language bug or a programming error.

For reliability, all ALCOR language compilers utilize state-of-the-art design techniques. The result is unequaled reliability and performance.

Mainframe power and sophistication on micro computers.

Are you tired of being told that the other language is a subset of the real thing? All ALCOR language systems are complete language implementations with all



of the features expected in professional programming environments.

Compatibility is a reality, not an advertising gimmick.

All ALCOR languages were designed by our own highly trained and professional staff of programmers. Not borrowed or copied, but exclusively created by us so that you can develop libraries of routines in any language that are callable from any other language.

ALCOR language systems run on a wide range of computer and operating system combinations.

Professional programmers know that the portability of a program is a crucial factor in applications. Rewriting applications every time you change computers is a waste of your valuable time and unnecessary with ALCOR languages.

If you want to develop quality software, do it with the quality language system from ALCOR.

MULTI-BASIC—A revolutionary approach to compiler design. MULTI-BASIC is the first language system to solve the BASIC compatibility problem. Not only does it support powerful features such as recursion, it compiles both MBASIC and CBASIC programs!

C—ALCOR C is the perfect tool for systems programmers. It is a complete C implementation as described in the Kernigan and Ritchie book "The C Programming Language."

PASCAL—A powerful Jensen and Wirth standard Pascal that is packed with the features necessary for serious program development such as random access files, dynamic strings and separate compilation.

These language systems are now available for most Z-80 based micro-computers with CP/M or TRSDOS compatible operating systems. 8086 and 68000 versions soon.

Yours for the asking!

Yes! Please rush via return mail your information package describing these new languages now available.

- Pascal
 Multi-Basic
 C Language.

Name _____

Address _____

City _____

State _____

Zip _____

FREE information-packed brochure.
 Call or write today to:



800 W. Garland Avenue, Suite 204
 Garland, TX 75040
 Telephone: (214) 494-1316

Dealer, Distributor and OEM Inquiries Invited.

TRS-80 and TRSDOS are trademarks of Tandy Corporation. CP/M and CBASIC are trademarks of Digital Research. MBASIC is a trademark of Microsoft.

© 1983, ALCOR Systems, Garland, Texas

LOOK AT ALBERT AND

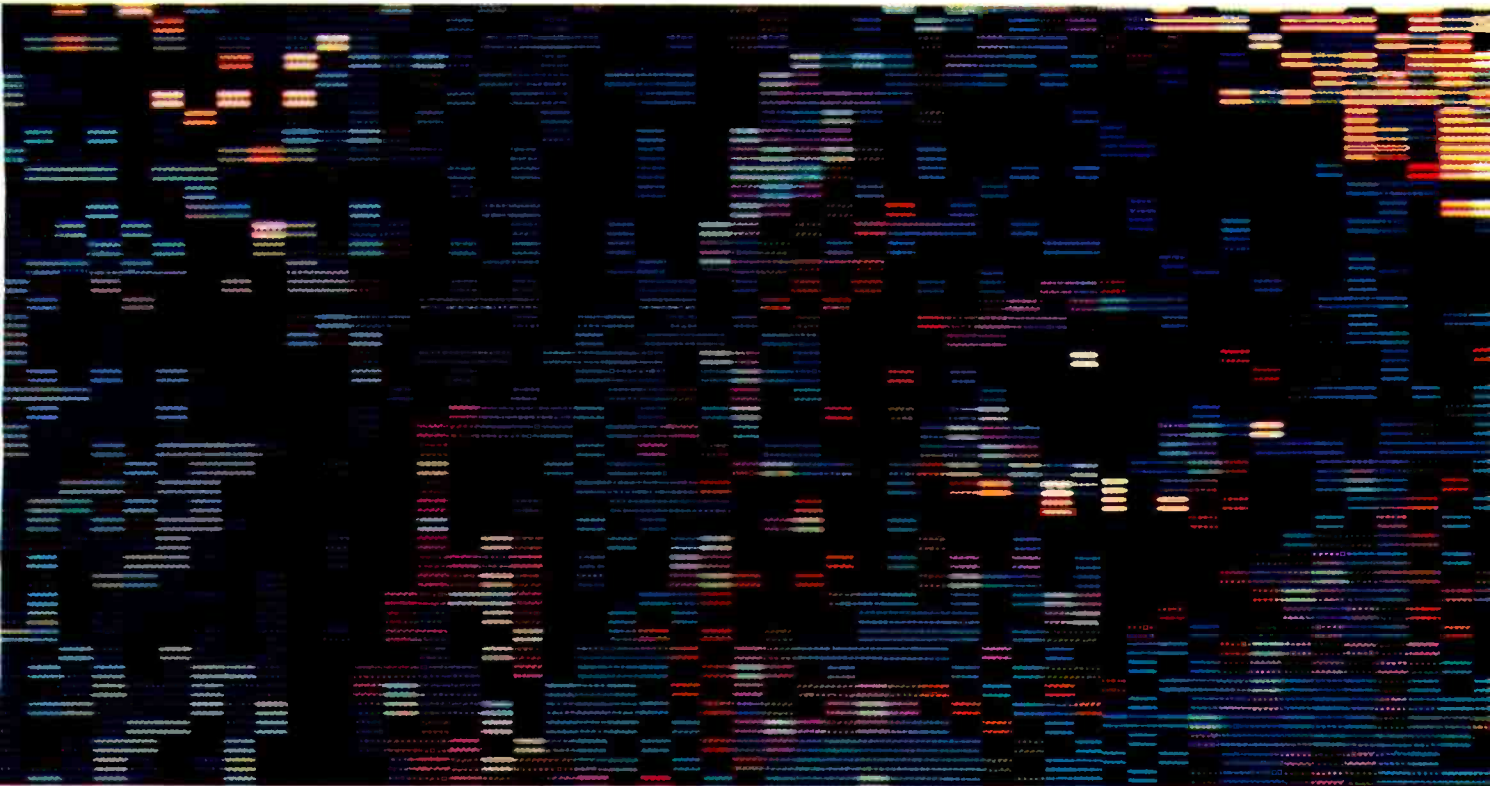

You've never seen a personal computer like Albert.

Albert provides basic work-alike access to over 15,000 programs of Apple-based software. But Albert is also designed with powerful, next-generation features for improved performance now—and spectacular applications yet to come.

Albert is ready to print and communicate.

Albert has the capability to hear your voice. Break it down for digital storage. Analyze and respond.

Albert can process and generate sound. Real voices. Artificial voices. In-

RGB output displays up to 16 on-screen colors from 256 selectable hues.

Parallel printer port.

A/D and D/A ports for voice input/output, audio control, digital storage.

Battery/charger ports.

110V AC or 12V DC. Albert operates anywhere.

Composite video output port.

Five fully buffered expansion slots. Albert can grow.

Detached serial keyboard.

Complete business Integrated software. Albert comes ready to work.

Graphics touch tablet generates images and business graphics with astonishing speed.

RS 232 communications with full handshaking.

RS 422/423 office networking levels.

Calendar clock for home security, document dating and control applications.

SEE THE FUTURE.



THE EYES OF ALBERT EINSTEIN, BY COMPUTER ARTIST SAUL BERNSTEIN. THE PORTRAIT IS MAGNIFIED AND PHOTOGRAPHED IN SECTIONS ON A BARKO CD33HR RGB MONITOR.

structions. News. Special alerts. Even music.

Albert can generate 256 subtle and brilliant colors—for text display, backgrounds and graphics.

And Albert can display everything with RGB high resolution brilliance.

Albert draws pictures and graphics literally with a touch of a fingertip. And with astonishing speed.

ALBERT VS. APPLE IIe.

	Apple IIe	Albert
Standard Computer	1395*	1595*
64K RAM Memory	Included	Included
Upper/Lower Case	Included	Included
Detached Keyboard	150	Included
Parallel Printer Port	50	Included
RS 232 Communications	100	Included
Networking Port	150	Included
Arcade Speed Game Port	150	Included
RGB Color	90	Included
S.A.M. Voice Output	100	Included
A/D, D/A Ports	150	Included
Battery/Charger Ports	N/A	Included
Calendar Clock	50	Included
Touch Tablet	100	Included
Integrated Software:		
Financial Forecast		
Word Processor		
Data Base Manager		
Mailing List		
Word Speller	540	Included
Battery + Charger	360	50
	3385	1645

Standard system configuration. Monitor and disk drives not included.

N/A = Not Available for Apple IIe.

*Standard computer price is manufacturer's suggested retail price. Other prices are actual or typical market prices of independent compatible products. All prices as published August, 1983. Prices subject to change.

Apple® is a registered trademark of Apple Computers Inc. S.A.M.™ is a trademark of Don't Ask, Inc.

Albert is incredible *fun*. Plug in a next-generation analog joystick, and watch what happens. Nothing, but nothing beats games on the Albert.

And Albert comes with a complete system of integrated business software. So you can put your Albert to work the day you get it.

Ask your Albert dealer for the Albert 60 Second Demonstration.

For the Albert dealer nearest you, write or call Albert Computers Inc., P.O. Box 6399, Thousand Oaks, CA 91359. Telephone 1 (805) 497-1073.

Albert.
The future of the personal computer.

Albert™

Moving Unix to New Machines

Some portability considerations and a case history of Unix for the NS16032

by Michael Tilson

Noted for its power and elegance, the Unix operating system is highly portable. As a result, largely compatible versions of Unix exist on a staggering number of computers. The task of moving ("porting," in Unix jargon) the operating system to a new machine, however, can prove challenging, as we will see.

Software History

Before we look at a case study, consider the trends that have influenced software development and the features that make Unix portable. A major development in the history of software has been the movement away from machine-specific (nonportable) code toward machine-independent (portable) code. The earliest computers were programmed in machine language, and the resulting programs would run only on a specific type of machine.

Later, high-level languages made it possible for programs to be written more quickly; these languages could directly express high-level concepts, freeing programmers from having to deal with many machine-level details. The high-level concept of addition, for example, is independent of the machinery that performs the calculation, and high-level languages that directly express the idea of ad-

dition with the + operator can free programmers from having to know the format of a particular machine-level ADD instruction. This programming ease made software usable on more than one type of machine when high-level languages were implemented on new machine environments.

Although languages quickly achieved a high degree of computational portability, things were not as easy when it came to noncomputational tasks. The operating-system environments in which the high-level programs ran were very different from one machine type to the next. Although the ability to open, read, and write files is as important in real-world applications as computation, each operating system had a different way of performing these basic functions as well as a different command syntax and a different set of utility programs for editing or file maintenance. Moreover, most operating systems required that the programmer deal with machine details (such as disk-track size) that were unimportant from an applications standpoint.

Unix Portability Advantages

In an attempt to overcome these drawbacks, Unix was designed to be portable. Because the Unix system

hides most machine details, it can serve a broad range of computers. In fact, Unix is available on machines ranging in price from a few thousand dollars to tens of millions of dollars. No other system has the same degree of portability (see table 1).

Portability, in this case, means that software developed for Unix can run without change on almost every available computer (if that computer is running Unix). Programmers also benefit from this portability. For example, a programmer using a 16-bit microcomputer version of Unix can make use of the full set of Unix utilities, and if he or she moves to an Amdahl mainframe, the same programming environment can be used. The same commands are used to copy or remove files or to compile C programs. A few details may be different, but the programmer needn't relearn everything.

Other operating systems take other approaches to portability. The original CP/M, for example, was portable in the sense that binary 8080 programs could be insulated from the details of device support. Because the 8080 (and Z80) was dominant in the early personal computer market, programs that used CP/M could run on many machines. However, most CP/M programs were written in 8080

assembly language, so moving these programs to new processors such as the 68000 is not easy. CP/M is also unable to provide some services needed by larger systems, such as multiprocess and multiuser support or a standard high-level implementation language. Thus, it does not span the range of machines Unix does. It is hard to imagine, for instance, the CP/M system in control of an IBM mainframe.

Another approach to portability that has achieved wide acceptance is the UCSD p-System.

P-System programs are typically written in Pascal. Like Unix, the p-System provides an entire operating environment. Because the p-System is interpretive, it is possible to write binary programs that can run on any p-System machine, making p-System applications highly portable. Unfortunately, the interpretation is inefficient. And, as with CP/M, the p-System environment lacks multiprocess and multiuser support and does not comfortably scale up to larger configurations.



Photo 1: *The NS16000 workstation, which includes memory-management and floating-point capabilities. This workstation was used to port a demand-paging virtual-memory implementation of Unix to the NS16032 processor.*

Another portability approach makes use of a "layer" of software. The layer's function is to hide the ugly details of the operating systems. The most widely known example of this is the Software Tools package, which provides a virtual operating system. With it, programs are written in highly portable FORTRAN (using a preprocessor to translate an enhanced language into standard FORTRAN). All operating-system functions are performed using only a standard set of library routines.

Thus, all that is required to move a program is standard FORTRAN and the necessary library.

Now consider the Unix system. It is portable at the source-code level; therefore, if an applications program is written in the C language using standard Unix system calls, that program should be portable to any Unix environment. The Unix system comes with a complete set of utility programs, so that large applications can be constructed using standard tools that function in the same way on all machines.

The system has enough power to be used on large machines as well as microcomputers.

What Makes Unix Portable?

To understand the portability of Unix, we must look at the steps involved in porting Unix. How does one get Unix on a new machine? There are three components: a C compiler, the Unix kernel, and the Unix utilities.

The Unix system is written almost entirely in the C high-level systems-

Altos	Ithaca Intersystems
Amdahl	LMC
Apollo	Masscomp
Apple	Megadata
Auragen Systems	Momentum
BBN	Mostek
Burroughs	Motorola
Callan Data Systems	Nabu
Charles River	National Semiconductor
CIE Systems	NCR
Codata	Nixdorf
Columbia Data Products	Onyx
Computer Automation	Paradyne
Computer Consoles	Perkin-Elmer
Computhink	Philips
Convergent Technologies	Pixel
Cyb Systems	Plessey Peripheral Systems
Data General	Plexus
DEC	Sun Microsystems
Dual Systems	Tandy/Radio Shack
Durango	Tektronix
Fortune Systems	Televideo
General Automation	Three Rivers
Gould S.E.L.	Torch
Hewlett-Packard	Univac
Honeywell	Western Electric
IBM	Wicat
ICL	Zentec
Intel	Zilog

Table 1: A partial list of manufacturers whose computers can run Unix.

implementation language. C is similar to Pascal, although C has a more abbreviated syntax, greater expressive power, and offers much more freedom to access low-level machine resources. The use of C is pervasive throughout the Unix code for both the system proper and the utility programs. Thus, a reliable C compiler is a prerequisite for porting Unix to a new machine. The portable C compiler is an important part of the Unix system. This compiler is designed to be adaptable to new machines.

The Unix system, which consists of approximately 200 programs, is structured in two levels: the kernel level and the user level. The kernel has full control of the machine resources, while user-level code has no direct access to any resource. The kernel is responsible for process management, I/O (input/output) support, and file-system management. All resource usage (for example, process creation, file creation, or file I/O) is accomplished by system calls to the kernel. There are about 40 important system calls. Over the years, additional features have been added to

the Unix kernel. These features are frills—the basic 40 system calls support 99 percent of the applications programs.

These system calls are machine independent to enhance Unix's portability. For example, the write system call writes an arbitrary number of bytes to a file at an arbitrary byte position. The parameters do not depend in any way on disk-track sizes or other hardware features. In fact, one can write to a file, a tape, or a line printer in exactly the same way. Most aspects of the file-system, process-management, and process-scheduling functions are also machine-independent.

The kernel interface is narrow and powerful. A small set of primitives provides the necessary services in a way that does not depend on the features of the underlying hardware. This hardware independence stems from the original Unix system's design, which was based on a simple but high-level notion of operating-system service; this concept is akin to the idea of providing the + operator in a high-level language rather than using machine-level ADD

instructions. Although the first versions of Unix were not portable (in fact, the earliest Unix system was written in assembly language), the high-level concepts involved are inherently portable. The "ideas" of addition and file I/O are the same on all machines.

The Unix kernel, which is mostly machine-independent and written almost entirely in C, consists of less than 20,000 lines of code. Roughly 1000 of these lines are low-level assembly-language support routines. Around 4000 lines are devoted to device, memory-management, and process support. If these 1000-line and 4000-line sections are rewritten, the kernel should run on a new machine.

The remainder of the Unix system (the kernel represents only a fraction of the total code) consists of machine-independent user-level code—even the Unix command interpreter is just an ordinary user-level C program that needs no special machine-dependent privileges at the hardware level. Therefore, to implement Unix on a new machine, you need only build a C compiler and implement the Unix kernel. In theory, everything else comes easily. In practice, it isn't that simple.

The Challenge of Porting Unix

One consideration in the implementation of Unix is its demand on hardware—Unix needs more hardware facilities than either CP/M or the p-System. For example, because Unix is a true multiuser, multiprocess operating system, it usually requires memory management and protection. Memory management enables the system to allocate processes to any free area of memory, and memory protection prevents one program from destroying the code or data of another program that may be running simultaneously. Memory protection is also used to enforce the narrow and well-defined interface between the user level and the kernel level.

Unix systems are oriented toward disk access. Users can request large amounts of work from the system (this means less work for people and

more work for machines). As a result, the system makes heavy use of the disk for program loading and file I/O. The design of the system revolves around the file system; therefore, it is not reasonable to run the system without a hard disk. Finally, most Unix configurations require at least 256K bytes of semiconductor main memory.

Although Unix is a powerful system, it can't run on all computers—the hardware must have a certain level of sophistication. An IBM Personal Computer with a hard disk probably represents the minimum configuration. Although the IBM PC, based on the 8088 processor, lacks memory protection, it can run Unix because it is a single-user machine and needs less memory protection than a multiuser system would.

Portability Problems

Given the right hardware, it seems easy to implement Unix. However, Unix is not perfect, and various problems will arise. For example, many Unix utilities make unfortunate assumptions about the underlying machine. It is usually easy to compensate for these assumptions on a machine for which they are false, but it can take some time to test all 200 Unix programs to discover any portability problems.

Ironically, some portability problems arise from features built into the C language, which was chosen in part to enhance Unix's portability. The C language is about twice as extensive as Pascal, mainly because many low-level features (such as arithmetic on pointers) have been included in the language to allow machine-independent programming. For example, if a C command increments a pointer by one, the pointer points to the location of the next data item in memory, not to the location of the next byte. (The latter result would typically occur in response to a hardware-dependent pointer-increment command.) Thus, with the C implementation, adding one to a pointer that points to a double-precision number yields a pointer to the next double-precision number; this operation has the same

meaning on all machines running C.

Unfortunately (at least from the standpoint of portability), however, some machine-dependent operations are also allowed in C. For example, C allows you to treat a pointer as an integer and to perform bit-masking tests on the value of that pointer. Although this capability can be useful for implementing functions such as storage managers, the capability is inherently nonportable because some machines store pointers simply as byte numbers while others use more complex schemes. If a program knows that a certain bit in a pointer indicates a certain fact, then the program can successfully run only on machines for which that bit indicates the same fact.

Another difficulty encountered in porting Unix is implementing the C compiler. On some machines, implementation is not difficult, but because the language is large and subtle, eliminating all of the bugs is never a trivial task. On other machines, construction of the compiler can be a formidable undertaking. For example, the "character" is a C data type, and the C language requires pointers to character (i.e., byte) locations. But some machines are word-addressed—their natural machine pointer can only refer to an entire 16- or 32-bit word, and the compiler may have to resort to extreme measures to provide the necessary byte pointers. At Human Computing Resources (HCR) our implementation team has implemented compilers for two such machines and has found the task difficult.

The C language is based on a simple model of the underlying hardware; some more complicated machines have been designed specifically for other languages such as Pascal. The implementation of a C compiler on single-language machines often requires ingenuity because all of those "good" machine features turn into obstacles that must be circumvented, subverted, or otherwise overcome. (For example, C and Pascal subroutine calling conventions are quite different. If a machine is designed specifically for the Pascal convention, implementation of the C convention may be difficult.) At HCR

we did it once, and we can testify that it isn't easy.

Once a C compiler is implemented, it is necessary to implement the kernel. Again, some machines fit well with Unix, while other machines have features that must be overcome. The closer the fit, the shorter the implementation time required.

Other problems are not so obvious. For instance, a machine may have used its own proprietary operating system for years, and the programs that drive its various peripheral devices (often written in assembly language) have been passed down from one generation of programmers to the next. In some cases, nobody has looked at the hardware manuals for years. Unix is a whole new system. The implementation team must sit down with the manuals and write the kernel hardware-support routines. Because the kernel is written in a high-level language, it will probably use all of the available hardware features. In fact, Unix is known for driving machines harder than any other system. When implementing Unix, programmers often find that the manuals are incorrect or incomplete or that some hardware feature has never before been used and doesn't work. This can wreak havoc with implementation schedules.

New machines have similar problems. The documentation may be incomplete or wrong. The machines may have design errors. Again, these errors are often not apparent in testing but show up under the load of a Unix system. Prototype machines especially tend to have reliability problems. Most programmers never expected to have to learn how to use a logic analyzer and often find tracking down subtle hardware errors a frustrating experience. At HCR, we often experience this problem because our implementation team usually uses prototype machines a year or more before they reach the public.

A Case Study: the NS16032

This case study provides some insight into the process of porting Unix. In mid-1982, we began work on our Unity version of Unix for the Na-



Predictable.

A flawless future is in sight with 3M diskettes.

When it comes to keeping track of precious data, predictable means reliable. Being able to count on every diskette, every time. At 3M, reliability is built into every diskette. We've been in the computer media business for over 30 years. And we've never settled in. We're constantly improving and perfecting our product line, from computer tape and data cartridges to floppy disks.

3M diskettes are made at 3M. That way, we have complete control over the entire manufacturing process. And you can have complete confidence in the reliability of every 3M diskette you buy.

Look in the Yellow Pages under Computer Supplies and Parts for the 3M distributor nearest you. In Canada, write 3M Canada, Inc., London, Ontario. If it's worth remembering, it's worth 3M diskettes.



Circle 548 on inquiry card.

3M hears you...

3M

tional Semiconductor 16032. (This work resulted in a public demonstration at the November 1982 Comdex show. That demonstration was the first public exhibit of a true demand-paged, virtual-memory implementation of Unix on a microprocessor.)

The National 16000 series is probably the most suitable chip set available for Unix. It has a 32-bit software architecture, so there are no unnecessary memory-addressing limits. The instruction set has been designed to support high-level languages. Architecturally similar to the DEC VAX superminicomputer, the 16032 has some additional features. Full memory management is provided with a standard chip, including demand paging, which allows virtual memory to be supported. A floating-point chip provides a true floating-point instruction set; the NS16032 does not rely on the cumbersome coprocessor scheme used by some other machines. Although the details and actual instructions are different, the machine may be described as a "VAX on a chip." Because the standard Bell Laboratory release of Unix ran on the VAX, we expected this implementation to be easier than others.

The basic process of a "Unix port" is simple, but there are many complicated details. The first step involves becoming familiar with the target machine. In my company's case, we took delivery of a prototype workstation from National Semiconductor (see photo 1). This station had all of the necessary equipment but no software except for some bootstrap ROMs and some diagnostics. All initial software development took place on a VAX 780 running Unix. (It is conceivable that one could port Unix without a nearby Unix development system, but it would be needlessly difficult.) A period of reading and experimenting ensued.

When doing work of this sort, it's always a good idea to start with similar software and modify it. We used the portable C compiler for the VAX and converted it into a 16000 compiler. A skeleton of the 16000 compiler already existed. Implementation of the compiler proper posed no great technical problems.

We did have to make a significant design tradeoff: the 16000 architecture allows global data and procedures to be directly addressed, or you can access data and code via the "module table." The latter procedure is a bit slower but results in smaller code because a user might often be able to use 8-bit offsets into the module table rather than full 32-bit address constants. We decided to use the module table because there are many benefits to having smaller code. Smaller code reduces program loading time and reduces the virtual-memory paging rate. The VAX does not have an equivalent feature.

The portable C compiler generates symbolic assembly code. That code is then assembled, and the resulting object module is linked with other modules and library routines.

The idea of porting Unix is simple; the implementation can become complicated.

The second step in porting Unix was construction of an assembler and linker. The main difficulties here involved the large variety of addressing modes and the correspondingly complicated program-relocation information needed by the linker. The module table added significant complexity. The assembler and linker probably involved as much work as the compiler.

Having "finished" the compiler/assembler/linker, we had to test the result. We developed down-line loading software so that we could compile programs on the VAX and run them on the National machine. We then started to test the compiler. During previous projects (HCR has ported Unix to a number of machines, including the MC68000, the Computer Automation 4/95, and the Three Rivers PERQ), HCR had developed an extensive test suite for the C compiler. This test suite requires minimal hardware support—only the ability to print characters. The test suite is not perfect, but it

does check out a large fraction of the compiler. On the National machine, the compiler stabilized quickly. Because the machine architecture is very regular, there are not a large number of special cases, which are often a source of compiler bugs.

In parallel with the compiler effort, we began work on the kernel. The first requirements were for a bootstrap loader, a low-level machine assist, some software to handle communication with the host development machine, and driver software for the disk unit. When these were met, we ran our first stand-alone programs. These stand-alone programs were some of the basic Unix maintenance programs, modified to call a library of stand-alone routines rather than the (as yet nonexistent) operating system. The programs were used for initial setup, such as construction of an empty file system on the disk or loading of files into the file system. This stage also checked out the team's fundamental understanding of the hardware.

The kernel was the next big step. We adapted a VAX version of Unix to run with the National hardware. As expected, most of the code ran unchanged. It was especially helpful that the memory-management scheme closely resembles that of the VAX. We used the demand-paging code from the Berkeley version of Unix. That code was far from perfect, but it did work, and it gave us a starting point. The initial kernel had a number of loose ends, but it was solid enough to start loading processes. We have an initial kernel test process that verifies that basic functions work correctly.

Once the initial kernel had come up, we were ready to finish the job. We started cross-compiling the utility programs, starting with the most important. (The utility that rebuilds damaged file systems is quite useful at this point because the system is still likely to crash from time to time.) At the same time, we finished off loose ends in the kernel. Moving utility programs was easy because the 16000 architecture is so similar to that of the VAX. In fact, it is hard for a C program to know that the

Apple II & IIe Centronics Printer Interface

- MULTIPLE DRIVERS ONBOARD IN EPROM (INTERCHANGABLE 2K RAM)
- APPLESOFT, PASCAL, & CP/M COMPATIBLE.
- 2 HANDSHAKE LINES: (ACK AND STROBE)
- 4 STATUS LINES: (SELECT, BUSY, PAPER OUT AND TRIME)
- CENTRONICS DATA BIT 8 MAY BE JUMPED LOW.
- CONVENIENTLY LOCATED RIBBON CONNECTOR.

PART NO. 22010 \$159.95

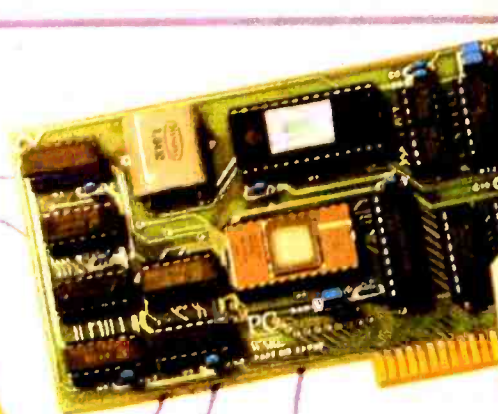
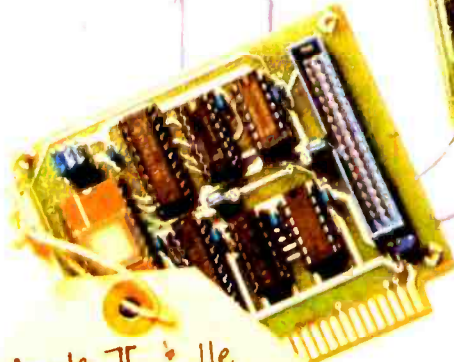

Apple II & IIe Serial Asynchronous I/O Interface (EIA- RS 232C)

- POWERFUL 2K INTELLIGENT DRIVER IN EPROM (INTERCHANGABLE 2K RAM)
- APPLESOFT, PASCAL, and CP/M COMPATIBLE
- SUPPORTS FULL and HALF DUPLEX
- CRYSTAL CONTROLLED BAUD RATES, SOFTWARE PROGRAMMABLE FROM 50 TO 19200 PLUS HARDWARE DEFAULT SETTING
- PROGRAMMABLE CONTROL REGISTER
- PARITY, OVERRUN, and FRAMING ERROR CHECKS
- SOFTWARE PROGRAMMABLE INTERRUPTS.
- DOUBLE-BUFFERED DATA
- CHOICE OF FOUR HANDSHAKE SIGNALS (JUMPER).
- DCD, DSR and/or CTS HARDWARE OVERRIDE (JUMPER)
- SIMPLE DCE/DTE CONFIGURATION HEADER

PART NO. 22030 \$184.95

Apple II & IIe Parallel I/O Interface

- MULTIPLE DRIVERS ONBOARD IN EPROM (INTERCHANGABLE 2K RAM)
- APPLESOFT, PASCAL, & CP/M COMPATIBLE.
- DUAL 8-BIT BI-DIRECTIONAL PARALLEL PORTS.
- FOUR HANDSHAKE LINES
- CONVENIENTLY LOCATED RIBBON CONNECTOR.

PART NO. 22020 \$89.95

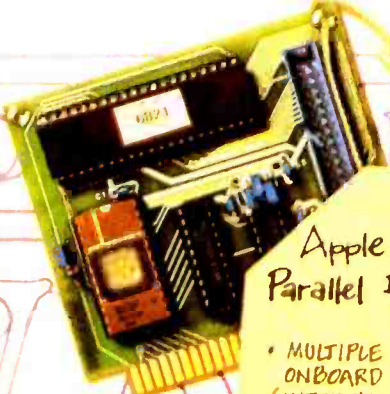

New for
Apple!

Circle 352 on Inquiry card.

PC
PERSONAL COMPUTER
WARE

PC WARE, INC.
Dept. B
4883 Tonino Dr.
San Jose, CA 95136
(408) 978-8626

TO ORDER In USA shipping paid by us for orders pre-paid. We accept C.O.D. orders (U.S. only). For VISA or MASTERCARD shipping charges will be added. CA residents add 6.5% for tax. Outside USA add 15% for shipping and handling. Payment must be in U.S. funds. Dealer inquiries invited.





PREVENT THE DISASTER OF HEAD CRASH AND DROPOUT.

The war against dust and dirt never ends. So before you boot-up your equipment, and everytime you replace a cassette, disk or drive filter, be sure to use Dust-Off® II; it counteracts dust, grit and lint. Otherwise you're flirting with costly dropouts, head crashes and downtime.

Dust-Off II is most effective when used with Stat-Off II. Stat-Off II neutralizes dust-holding static electricity while Dust-Off II blasts loose dust away. There's also the Dual Extender and Mini-Vac for vacuuming dust out of hard-to-reach places.

Photographic professionals have used Dust-Off brand products consistently on their delicate lenses and expensive cameras for over ten years. They know it's the safe, dry, efficient way to contaminant-free cleaning.



Cleaning not provided by liquid cleaners.

Dust-Off II's remarkable pinpoint accuracy zeroes in on the precise area being dusted. And you have total control—everything from a gentle breeze for



Stat-Off II neutralizes dust-holding static electricity from media and machines.

delicate computer mechanisms to a heavy blast for grimy dirt.

Don't let contamination disrupt your computer operation. Stock up on Dust-Off II—the advanced dry cleaning system,

at your local computer or office supply dealer.

Or send \$1.00 (for postage and handling) for a 3 oz. trial size and literature today.



Dust-Off® II

The safe dry cleaning system

Falcon Safety Products, Inc., 1065 Bristol Road, Mountainside, NJ 07092

machine is not a VAX. This is in stark contrast to other machines in our experience. The major task was to verify that all of the utilities are operational. Again we employed a test suite. As a result we found a few more compiler bugs and one or two kernel bugs.

Some other programs require adaptation to the specific machine (for example, the FORTRAN compiler). We also added a few extra system features, such as bitmap display support.

Moving C programs to the 16032 was easy because the 16000 architecture is similar to that of the VAX.

All of this sounds too easy. In fact, we did encounter some difficulties. Nearly all of the problems stemmed from the fact that we were using prototype hardware with engineering sample chips. At one time or another, everything that could go wrong did. There were errors in the documentation. The disk did not work. The disk controller did not work. The central processor board did not work. The central processor chip did not work. The memory-management chip did not work. The interrupt controller did not work. The floating-point chip did not exist at first and then did not work. The problems were usually intermittent, often subtle, and always maddening.

(Important note: it would be false to conclude that the National chips or hardware are unreliable; these problems always occur with new chips or prototype hardware. Before parts reach production quality, they exist in experimental form. National provided good support during the project and the problems have been solved. We have since then had excellent success in making our product run on original equipment manufacturer (OEM) machines using the 16032 processor. Because chip-development cycles are long, we

Introducing ULTRAFRAME™ the multitasking, multiuser system designed for system integrators & OEM's.

FRONT VIEW

Mainframe-like Chassis Engineering Attractive aluminum chassis offers continuous-duty capability plus all the flexibility you'll need in one desktop system. Tailor a package to your unique needs. Even put your name on the front.

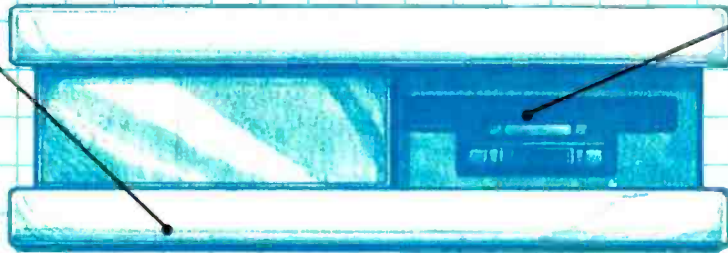

Integral 5" & 8" Floppy Drives Your choice of 5" or 8" half-height drives — up to 1.2 MB capacity.

TOP VIEW - SHOWING INTERIOR

Both 8 and 16 Bit Capability Our system is designed to accommodate both 8 and 16 bit Slavenet processors at the same time. Gives you access to the widest range of software with upward mobility in the same chassis.

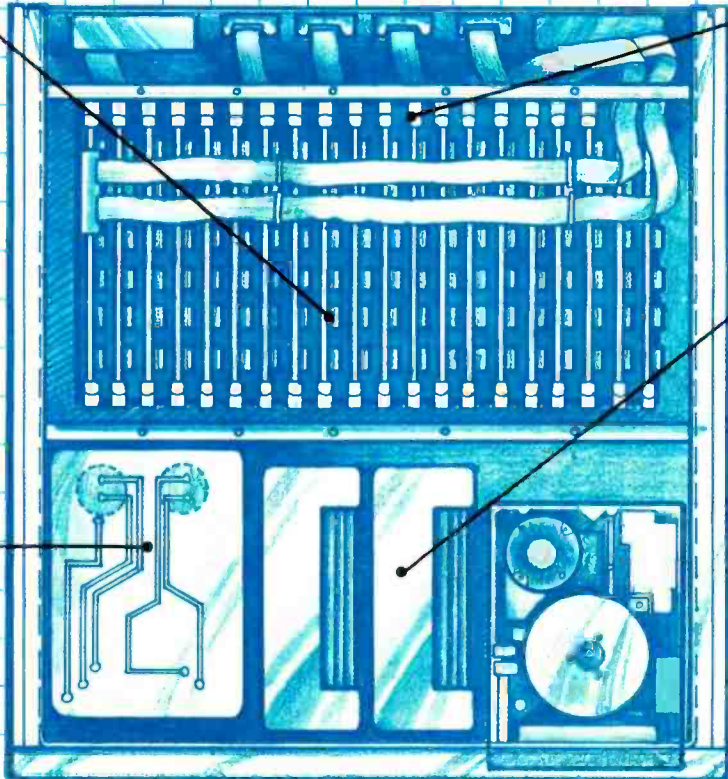

Up to 32 Users — in Parallel Our multiprocessor system uses up to 16 Slavenet™ processor boards — each a complete Z80 computer with 64K RAM per user — to maintain fast, multi-user performance as you add users or tasks. Both 12 and 20 slot S-100 models available.

Low Cost Per User Give your customer high performance and lower cost per user than any micro network. They get true multi-user, multitasking operation plus shared resources — and you get a customer for life.

Fast, High-Capacity Hard Disks Full range of fast 5" & 8" Winchester drives from 10 to 120 MB (formatted), including new high-capacity 5" models. Most 5" models have provision for adding a second drive later on. Also, 14" drive models from 145 MB to 1,160 MB.

High Capacity Power Supply Engineered to support max. load under continuous operation with two-level filtration. Easy 110/220V, 50/60 cycle switching. Solid state circuitry for max. reliability. Power regulation heat sunk to chassis.

Fast, Multiprocessor Operating Systems We offer IBS p-NET™ and TurboDOS™ — proven multiprocessor operating systems for fast, multitasking applications. Access to all UCSD-Pascal™ and CP/M™ software.

BACK VIEW

BACKSTOP™ — Video Archiving Plug in any standard video recorder to archive up to 100 MB of data. Fast, low-cost backup system for hard disks (optional).

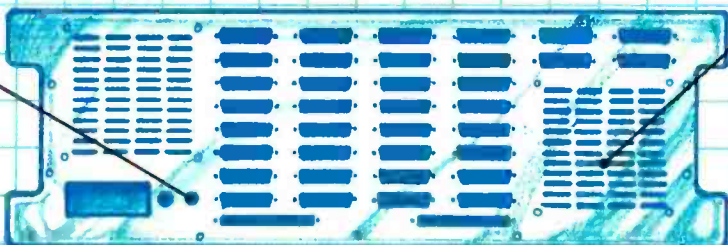

Dual Whisperfan Cooling Two high-capacity fans assure adequate cooling for around-the-clock operation. Maximum air flow around all drives and critical components.

See us at
COMDEX/Fall '83
November 28-December 2, 1983
Las Vegas Convention Center.

UCSD-Pascal™ is a trademark of the Regents of U. of C.
CP/M is a trademark of Digital Research, Inc.
TURBODOS is a trademark of Software 2000.
IBS is a trademark of IBS, Inc.

Three-Year Warranty IBS gives you the clincher — a premium warranty to back a premium product. At a competitive price. Ask about our dealer support program.

ULTRAFRAME™

ibs
INDEPENDENT BUSINESS SYSTEMS

Call collect (415) 443-3131. TWX: 910-386-6003. IBSNET
5915 Graham Court, Livermore, CA 94550

often had to patch around the problems to continue work. We were only able to demonstrate at Comdex because of the quality, dedication, and perseverance of the implementation team. This kind of debugging requires a high level of expertise. Having to do this debugging is the penalty you pay for being on the leading edge—if you wait for the final production hardware, you won't be first.)

Finishing the Job

Many people think that it is easy to bring up the Unix system on a new machine. In fact, it is possible to bring up a limping kernel with a

buggy compiler in about four months. However, to bring up a system with all of the utilities, with an allowance for inevitable problems, with some performance tuning and commercial enhancements, and with everything tested and solid, takes about a year. Once Unix has been ported to a particular hardware type (e.g., the 16032 chip set), you can adapt the system to other configurations fairly quickly. Each OEM will use the chip set to build systems with various bus structures and I/O devices. Adapting Unix to a new configuration can take from one or two weeks (if the target machine works and only one or two device drivers

are required) to several months (if the hardware doesn't work or is otherwise intractable, or if "strange" devices must be supported). Some people also refer to this configuration process as "porting" Unix, but the final process of adaptation to OEM requirements is not nearly so difficult. ■

Michael Tilson is vice-president for technical development at Human Computing Resources Corporation (10 St. Mary St., Toronto, Ontario M4Y 1P9, Canada). He has many years of experience with Unix and Unix-based software products. He has been involved with the implementation of Unix on several machines and is actively involved with industry efforts to increase the level of standardization of Unix-like systems.

A compiler for MODULA-2? An interpreter for PROLOG?

MODULA-2/P-CODE • MODULA-2/NATIVE CODE • PROLOG INTERPRETER

Available October 1983 Prices starting at \$495.00

from:



Springer-Verlag New York
175 Fifth Avenue
New York, N.Y. 10010
Att: Mark Langweiler

Springer-Verlag New York Berlin Heidelberg Tokyo

Buy the People for the people.

OLYMPIA
'PEOPLE'
MICROCOMPUTER

STANDARD FEATURES

- TRUE 16 BIT CPU*
Intel 8086 Microprocessor
- 128k READ/WRITE MEMORY (RAM)
Expandable to 512k
- BUILT-IN DUAL FLOPPY DISK DRIVES
1.3 Megabyte Total Storage
- HIGH RESOLUTION TEXT/GRAPHICS
25 Lines by 80 Columns
640 by 475 Pixel Resolution
- DETACHABLE, LOW-PROFILE KEYBOARD
12 Function Keys
Numeric Keypad

ALSO AVAILABLE

- CCP/M-86™
- COLOR MONITOR
- 10 MEGABYTE
WINCHESTER HARD DISK

AND MUCH MORE

RUNS CP/M-86™ and MS-DOS™

The following names are trademarks of the following companies. CP/M-86™ and CCP/M-86™—Digital Research, MS-DOS™—Microsoft, WordStar™—MicroPro, SuperCalc™—Sorclm, dBase II™—Ashton-Tate. *16-bit microprocessor with 16-bit databus

Introducing the People personal microcomputer from Olympia. Engineered to be powerful. Engineered to be people-friendly. Engineered for office performance.

In fact, chances are you can't buy a personal microcomputer that gives you more for your money. Because the People has all the features that ensure the system will be just as viable tomorrow as it is today. And it's compatible with major software packages, such as WordStar™, SuperCalc™

and dBase II™.

For more reasons why you should buy the People for your people, send for our free brochure: Olympia USA Inc., Dept. BY10, Box 22, Somerville, NJ 08876.

Or call the Olympia Sales Office in:

New Jersey—(201) 722-7000;

NYC—(212) 697-9051;

Chicago—(312) 640-0300;

Sealy, TX—(713) 885-7473;

El Monte, CA—(213) 350-4173;

Burlingame, CA—(415) 692-2880.



 **OLYMPIA®** Engineered
for office performance.

© 1983 Olympia USA Inc

Circle 334 on inquiry card.

BYTE October 1983 277



SOMEWHERE, OUT THERE, A BEST-SELLING PROGRAM

WHERE IS IT?

Wherever it is, we want it. Maybe, just maybe, we're searching for your program, but we'll never find it unless you call us.

It has to be good, though. Because we're the Software Guild™, an organization devoted to finding the very best microcomputer programs for packaging and distribution under the Softsmith™ label. Hundreds of titles have already been licensed to the Softsmith library. But they're only the beginning. Our goal is to have the best program in major categories on every

popular machine. Of course, we can't do it without you.

If you're a program author or publisher, The Software Guild offers some distinct professional and monetary advantages.

First, you devote your time to what you do best: programming. You can leave the manufacturing, packaging, documentation, distribution and customer service to us.

Second, our revolutionary retail merchandising system will put your program before the public through the normal computer and software stores, plus record outlets, department stores, book shops, and more places where software has never before been available.



IS BEING WRITTEN.

Third, is royalties. Wider distribution means more substantial royalties. And, your Software Guild royalties start to accrue when the dealer makes his purchase in quantity, so you aren't left waiting while money trickles in.

Fourth is flexibility. We do not insist on the exclusive rights to your program. You can deal with other publishers and distributors, or market your program yourself, while it is in Softsmith distribution.

We know you're out there, working and dreaming, and we want to help make your dream come true. Our full staff of professional evaluators are waiting to review your best-seller.

**So call us, wherever you are.
Contact Regina Roberts at (415) 487-5200.
Or write:
The Software Guild
2935 Whipple Rd.
Union City, CA 94587**



The Software Guild™
(415) 487-5200

The NEC Advanced Personal Computer

High-resolution graphics, color, and 16-bit performance in an attractive package

by David B. Suits

Not long ago, I started looking for a new microcomputer. Actually, I wasn't looking so much as musing about which computer would be a significant step up from my 8080-based system. My next computer, I knew, would have a 16-bit CPU (central processing unit). It would use Digital Research's CP/M-86, have a high-resolution color-graphics display, and come with dual 8-inch disk drives. The drives would be arranged so that the disks could be inserted vertically. (Perhaps I have strange wrist bones, but I find it uncomfortable to have to load disks horizontally.) I also wanted a detachable keyboard with four cursor-control keys arranged in a diamond-shaped pattern. The keyboard would have to have a separate calculator-style keypad for easy entry of numeric data and some special-function keys to make application programs (such as word processors) easier.

Nothing advertised in the magazines met my requirements. I thought I would have to start making some compromises.

The APC

Perhaps NECIS (NEC Information Systems) read my mind. Its APC (Advanced Personal Computer) fulfilled my expectations (see photo 1) and, in fact, exceeded them. The NEC APC also has double-sided double-density disk drives; the keyboard has 22 programmable function keys; there is a user-definable character set; and the system includes a real-time calendar/clock, a single-voice music generator, 128K bytes of RAM (random-

access read/write memory), and 4K bytes of battery-powered RAM that will retain data even when the computer is off (see At a Glance box on page 284). There is also an automatic power-off feature so the machine can be turned off under software control.

The APC is available in a monochrome or color model. The monochrome model comes with one disk drive; two drives are optional. The color model comes with two integrated drives. The disk-controller chip, the NEC 765, handles up to four single- or double-density floppy-disk drives. Having "grown up" with single-density 5¼-inch disks, I was impressed by the new double-density 8-inch disks. The formatted capacity of each disk is 1 megabyte, and data is transferred via DMA (direct memory access) at 62.5K bytes per second.

The APC Display

The 12-inch CRT (cathode-ray tube) display is handled by NEC's 7220 GDC (Graphics Display Controller), a complex and powerful chip that can control up to 256K 16-bit words of display memory, partition the display into four text or graphics areas, and perform figure drawing, area fill, panning, and zooming. The APC display refresh memory (without the optional graphics subsystem installed) consists of 12K bytes of static RAM separate from the 8086 microprocessor's main memory.

The screen has 25 lines of 80 characters each, with a 26th line, or status line, at the top (see photo 2). The status line shows a digital calendar/clock, indicates which

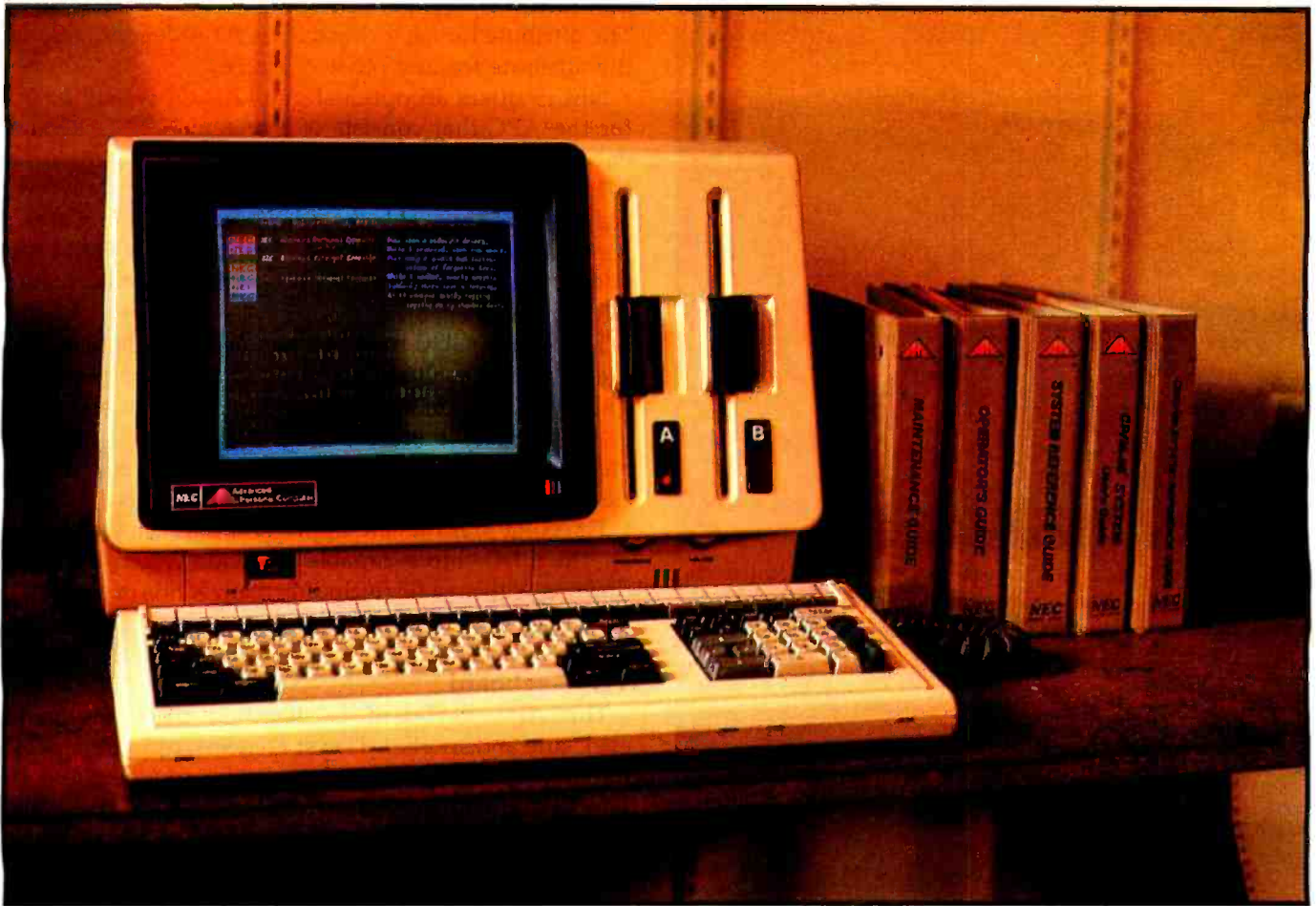

Photo 1: The NEC APC (color model), with five volumes of documentation. The main power switch is under the display. The brightness and volume controls are under the disk drives. Note the main power cord, which attaches to the front of the system.

of four latching-switch keys is down (Caps Lock, Grph1, Grph2, and Alt), and shows what NECIS calls the "speed," a number from 0 to 9 that indicates the relative speed with which characters are output to the screen. (The speed is user-determinable from the keyboard, but it is not clear where its usefulness lies.)

Each of the character positions on the screen is composed from a matrix 8 pixels wide by 19 pixels high. While some APC special characters use the entire width or height of the matrix, the ASCII (American National Standard Code for Information Interchange) characters are displayed in an 8 by 13 subarea, and the user-defined characters are formed in an 8 by 16 subarea.

The 8 by 19 character box and the 25-line by 80-character screen give the screen a resolution of 640 pixels horizontally by 475 pixels vertically. However, the status line at the top of the screen also occupies display memory, so the actual vertical resolution is 494 pixels. NECIS's CBIOS (customized basic input/output system) routines that come with CP/M-86 allow for turning the status line on and off but not for moving the cursor into that line. To make use of the full 26 display lines, I had to write a custom routine to handle the GDC. The documentation supplied with the APC is extensive but

seemed complex. After I understood the basics of the GDC, however, I found that it was relatively simple to get it to do what I wanted in the way of cursor, character, and attribute manipulation. The powerful graphics features of the GDC are a bit more difficult to manage, and I have only recently begun to tackle them.

Any display character may have six attributes: overline, underline, vertical strike through, reverse video, blink, and color. The overlines, underlines, and vertical lines always appear in steady green, even if the character appears in some other color or is blinking.

There are eight screen colors available: black, red, blue, purple, green, yellow, light blue, and white (see photo 2). (I prefer "magenta" to "purple" and "cyan" to "light blue," but NECIS uses the less esoteric names. On the other hand, NECIS refers to black as "secret.") In the monochrome version only black, green, and "highlight" (bright green) are available as color attributes. When the "reverse" attribute bit is set, the selected color appears as the background for the character, and the character itself is black. (I wish there were a way to select foreground and background colors on the color model so characters could appear in any of the eight colors against any of eight background colors. But that would require

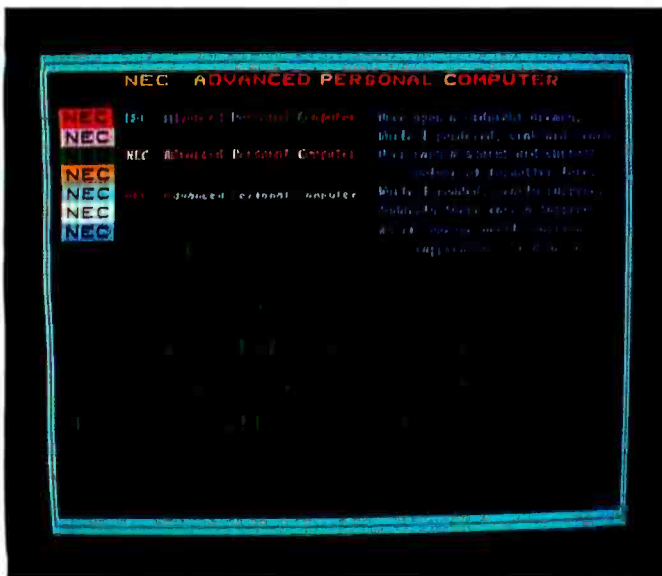

that each character's attribute be extended by three bits.) The attribute for each character is set independently of the attribute for any other character.

NECIS offers an optional graphics subsystem board for the APC that consists of a second 7220 GDC and enough memory to specify the color for each pixel in a 1024 by 1024 array. (The actual screen display, however, is a 640 by 494 movable "window" into that larger area.) For the monochrome model, 128K bytes of RAM are added; for the color model, the graphics board contains 384K bytes.

The second GDC runs independently of the first, and the outputs of each are combined and sent to the screen. This means not only that text and high-resolution graphics may be displayed simultaneously, but also that they are manipulated independently of each other (like two transparent display planes, one on top of the other).

The color graphics are impressive and fast (see photo 3). The GDC chip is capable of a wide variety of figure drawing with area fill (including many kinds of patterns), panning, and zooming.

The Keyboard

The APC keyboard is detached from the main enclosure and sports 108 keys; 22 are user-programmable function keys on the top of the keyboard (see photo 4). The KEY utility program provided on disk allows the user to program only the first 16 of these keys; the remaining six keys are "reserved," although no definite use is claimed for them anywhere in the documentation. They are programmable, but you would have to dip into the CBIOS routines to program them. To the left of these function keys is a key labeled FNC, which acts as a shift key, giving each of the 22 function keys a second function (also programmable).

In addition to the alphanumeric and programmable function keys, there are, on either side of the space bar, four new keys: Grph1, Grph2, Alt, and Help. The Grph1 and Grph2 keys access the APC's special characters (Greek letters, mathematic symbols, and character graphics). The Alt key is supposed to allow access to the user-defined character set, but it does not. (I had to write my own assembly-language routine to access this set. In the process I discovered that the APC's CBIOS routines could have easily allowed the Alt key to access the user-defined characters, but, for some reason, did not. I suspect that it was a mistake that might be remedied with one or two additional instructions in the code.) The Help key ordinarily echoes as a question mark, but application programmers may reprogram it to present help messages.

Separate from the main set of keys is a 25-key cluster including a numeric keypad, a Delete key, an Insert key, a Clear/Home key, a Print key, a Break/Stop key, and four cursor-control keys. The CP/M-86 utility programs recognize the Break/Stop key as a Pause key (Control-S); pressing it once causes processing to stop and pressing it a second time causes processing to continue. Pressing Shift along with the Break/Stop key generates Con-

Photo 2: The APC display, showing normal ASCII characters, special characters, and user-defined characters. Eight colors are available (in normal and reverse video), plus underline, overline, vertical line, and blink.

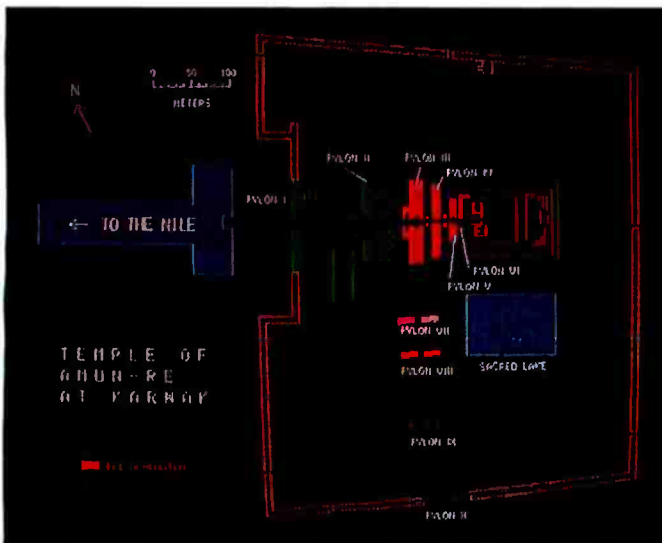

Photo 3: Examples of color graphics on the APC. Although each pixel may be only one of eight colors, different colored pixels that are close to each other appear as new hues or shades.

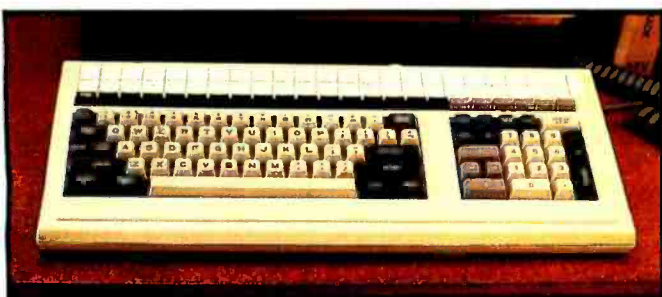
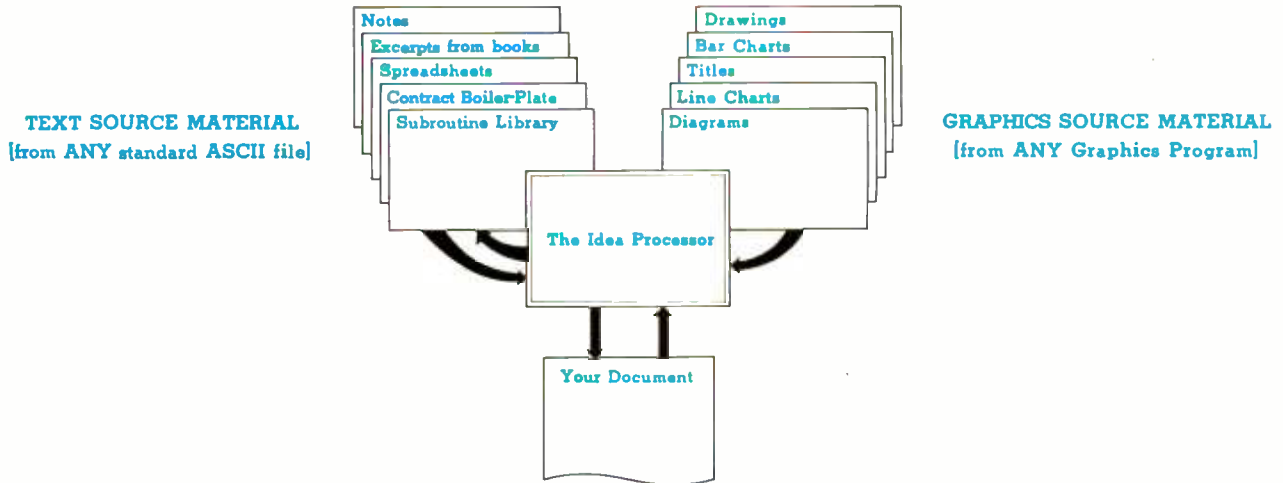

Photo 4: The APC keyboard. Twenty-two programmable function keys are above the regular keys. At the top of the keyboard is an overlay strip that can be used to indicate the programmed functions of the special keys. Notice that the left Shift key is upside down (see text).

THE IDEA PROCESSOR™

A NEW CONCEPT IN THE MANAGEMENT OF TEXT AND GRAPHICS

Much more than just the finest text editor—much more than just the most powerful cardfile system—much more than just a comprehensive document formatter—it's an integrated system that provides incredible power in the manipulation of text, graphics (from any source!), spreadsheets, programs, or just about any kind of information you can store in a file on your IBM Personal Computer. Index your source material—spreadsheets, graphs, excerpts from letters, memos, contracts, books—then build your document, using the marvelous Idea Processor editor in conjunction with the instant text database access afforded by the Cardfile. Or copy sections of your document into your own cross-indexed archive: legal boiler-plate, literary quotations, subroutine libraries—you design it. Cross-index each citation up to 10 ways. Print your document with auto-footnoting, auto-indexing, and imbedded graphs and spreadsheets. The Idea Processor thinks along with you . . . to multiply your productivity.



The Idea Processor is more than just a program. It's even more than a software system. It's a new way of looking at the management of text, graphics, and documents. Use it to build your next contract, program, memo, letter, or article. You'll see what we mean.

- The finest Editor available
- The most powerful Cardfile program available
- Editor and Cardfile are completely integrated and operate simultaneously
- Fastest data base access
- Move all or any part of a card to the document, or vice versa
- Manages up to 64,000 cards in a data base
- All commands entered via function keys or labelled keys for ease of use
- Constantly available function key information
- Eighteen full screens of HELP messages at a keystroke
- Keyboard MACRO commands replace 100 keystrokes with a single keystroke
- On screen underline and **Boldface**
- Edits files up to 160K
- Saves and indexes spreadsheets and graphics generated by any program
- Incorporates spreadsheets and graphs in printed text
- Auto Footnoting and Auto Indexing
- Bi-directional continuous line and page scrolling
- Uses full power of IBM keyboard and printer
- Complete novices use it comfortably in an hour; full proficiency in four hours

The Idea Processor

\$295

Integrated editor and cardfile program, text formatter, graphics management to integrate graphics from other programs into document and cards

Requires an IBM-compatible personal computer with 192K of memory

From your dealer or:



225 Lafayette St.
New York NY 10012
212-334-8043

Circle 219 on inquiry card.

Idea Processor is a trademark of IdeaWare Inc.
IBM is a trademark of International Business Machines Inc.

Visa and MasterCard

At a Glance

Name

NEC APC (Advanced Personal Computer)

Manufacturer

NEC Information Systems
5 Militia Dr.
Lexington, MA 02173
(617) 862-3120

(NEC Information Systems should not be confused with NEC Home Electronics, distributors of the PC-8000 microcomputer, although both organizations are divisions of Nippon Electric Company, Ltd.)

Dimensions

Main enclosure: 18.5 by 13.8 by 18.1 inches; keyboard: 18.9 by 2.2 by 8.5 inches

Weight

Main enclosure: monochrome model—52.8 pounds (24 kg); color model—74.8 pounds (34 kg); keyboard: 5.1 pounds (2.3 kg)

Power Requirements

105 volts to 130VAC, 50/60 Hz; 150–340 watts maximum (without options)

Processor

5-MHz NEC PD8086 16-bit microprocessor

Memory

4K bytes of bootstrap ROM, 128K bytes of dynamic RAM (expandable to 640K bytes in increments of 128K bytes), and 4K bytes CMOS RAM with battery backup power

Standard Configuration

Main unit with integrated CRT display, integrated disk drive(s) and five-slot card cage, parallel-printer interface, RS-232C synchronous or asynchronous serial interface, programmable music generator with speaker, hardware calendar/clock, 108-key keyboard

Video Display

12-inch diagonal CRT with long-persistence phosphor,

black/green/highlight (monochrome model) or eight colors (color model), 80 characters by 25 lines plus a 26th status line. Video resolution is 640 by 494 pixels with underline, overline, vertical line, reverse video, and blink. Character ROM has 224 characters with 256 user-definable characters. The video is controlled by a NEC 7220 Graphics Display Controller

Keyboard

Detached with 108 keys, including four cursor keys, a numeric keypad, and 22 dual-mode programmable function keys

Disk Drives

One (standard with monochrome model) or two (standard with color model) 8-inch double-sided double-density floppy-disk drives with a capacity of 1.2 megabytes each (single-density disks are also supported), integrated into the main enclosure

Options

RAM expandable to 640K, second serial interface, 8231 arithmetic chip, graphics subsystem board, hard disk, prototyping boards

Software Supported by NECIS

Accounting Plus (\$695), Benchmark Word Processor (\$495), Benchmark Telecommunicator (\$95), Benchmark Mailing List Manager (\$195), Microplan Financial Spreadsheet (\$195), Microplan Business Planner (\$495), dBASE II (\$695), CP/M-86 (\$150), MS-DOS (\$150), various terminal emulator and communications packages (from \$245-\$1485)

Prices

APC-HO1 (monochrome, one disk drive)	\$2748
APC-HO2 (monochrome, two disk drives)	\$3448
APC-HO3 (color, two disk drives)	\$4198
Additional 128K bytes RAM	\$ 700
Each additional 128K bytes RAM	\$ 200
Monochrome graphics subsystem	\$ 448
Color graphics subsystem	\$ 648
Arithmetic coprocessor chip	\$ 250
Additional serial port (with cable)	\$ 335
12-megabyte hard disk	\$2698
Second hard disk	\$2398
Engineering-development boards	\$ 89

trol-C, which CP/M-86 interprets as an interrupt. Print is a convenient way to issue Control-P and causes data being sent to the screen to be sent to the printer as well. Pressing Print a second time turns off that function. Del acts as an "erase input line" key (Control-X). Ins, which issues character code 1C hexadecimal, is merely echoed as Control-backslash. Clear/Home sends the cursor to the top left corner of the screen; pressing it in conjunction with Shift will erase the screen.

The four cursor-control keys are positioned in a diamond shape so that the up-arrow key is on top, the left-arrow key is on the left, etc.

There is a useful feature that enables the screen to act as a "window" into a 50-line display area at any given time. Using the Control key in conjunction with the up- or down-arrow keys causes the window to move up or down through the larger display area, so that up to 25 lines that have already scrolled up and off the screen can be easily displayed.

The keys have an excellent feel and sound. It is the fastest and most comfortable keyboard I have used, and typing on it is a joy (with one exception, which I'll mention later).

Inside the keyboard is an 8048 8-bit microprocessor that monitors the keys. When a key is pressed, the 8048 decodes it, sends an interrupt request to the 8086, and presents the key code to one of the 8086's ports. At the same time, the status of the switch keys (Shift, Control, etc.) is presented to another port. When the 8086 acknowledges the interrupt, a software routine reads the keyboard data into a 64-byte FIFO (first in, first out) buffer. This manner of handling the keyboard has two desirable consequences. First, it relieves the 8086 from having to interrupt what it is doing to poll the keyboard every so many milliseconds to see if a key is pressed; second, the 64-byte buffer acts as a type-ahead buffer so that if you type faster than the application program can process the input, no characters are likely to be lost.

We Offer You More!

That's right. If you compare the benefits of ordering from National Computer to all our competitors, you'll see why more smart shoppers buy from us every day. We save you money even before you order with our toll free 800 line, and then if you find a lower advertised price we'll meet it. Since we stock what we advertise you can rest assured your order will be shipped promptly. In addition, if for any reason you are not satisfied with any merchandise you purchase from National Computer you may return it for exactly what you want or a full refund. Check us out! We've been in business for over 4 years, and one glance at our catalog will demonstrate the commitment we have to direct marketing and to our fine customers.



VIDEO MONITORS

AMDEK 300 12" Hires green	145**
AMDEK 300A 12" Amber	159**
AMDEK Color Plus 13" Color	329**
AMDEK Color Plus Hires RGB	439**
AMDEK 310G Green	179**
AMDEK 310A Amber	179**
COMREX 360U 12" Hires amber	169**
NEC 1201M 12" Hires green	159**
Princeton PGS 4K-12	499**
TAXAN Vision 12" Hires RGB	329**
TAXAN Vision 3 12" Hires RGB	499**
TAXAN 12" Hires amber	149**
ZENITH 12" Hires green	110**



KAYPRO

The anytime, anywhere computer. Includes CP/M, CBASIC, a spreadsheet and wordprocessing software. PLEASE CALL FOR MORE DETAILS.



KOALA TOUCH TABLET

A new dimension in computer control with the touch of a finger. Special price 109**



QUADCHROME BY QUADRAM

High Resolution 12" RGB color monitor.
• 80 character x 25 lines
• 690K x 240V dot resolution
• 16 colors, high & low intensity
• Includes IBM PC cable
• Very affordable

Only \$529.95

We carry the Princeton PGS MX-12 for only \$499.95



SWEET-P PLOTTER

A simple to operate plotter which easily interfaces to the PC using a centronics parallel port. Complete with software, set of pens, paper and operators manual. List Price \$795.00. Special Offer \$599.00

DISKETTES

Buy 100 for only \$219.95

3M Scotch 5 1/4" SS/DD	25**
3M Scotch 5 1/4" DS/DD Box of 10	35**
Verbatim 5 1/4" SS/DD Box of 10	29**
Head Cleaning Diskette 5 1/4"	27**



POPULAR SOFTWARE

WordStar by MicroPro	269**
Random House Encyclopaedia	129**
MailMerge by MicroPro	169**
SuperSort by MicroPro	169**
SpellStar by MicroPro	169**
dBase III/IS DOS or CP/M/86	429**
LOTUS 1 2 3	429**
PC Tutor by Comprehensive	69**
Home Accountant Plus	115**
Crosstalk by MicroStuf	129**
Peachtree GL/ARAP 4 pak	399**
SuperCalc by Sorcim	139**
VisiWriter by Lettface	139**
Microsoft Multi-Plan	179**
Microsoft Flight Simulator	39**
VisiCalc	169**
VisiFile	219**
VisiTerminal/Print	219**
VisiSchedule	219**
VisiWordreq (128K)	299**



HAYES IBM PC MODEM

Smartmodem 1200B with communications software



QUADLINK

by Quadram

Only \$499.95

Now you can run Apple software on your IBM PC. Advanced technology from the IBM PC peripheral leader Quadram has made it possible. Quadlink allows you all IBM enhancements while running Apple software, including all peripherals. Now you can enjoy the best of both software worlds including hires games special packages not available on the IBM PC. Apple/ve your IBM today!

Modems

Hayes Smartmodem 300	219**
Hayes Smartmodem 1200	489**
Noraton J Cal 0300 baud	114**
Anchor Mark III 300/1200 baud	99**
Anchor Mark VIII 300/1200 baud	99**
RIXON PC212A (IBM PC)	CALL
CACTUS Technology IBM PC	299**

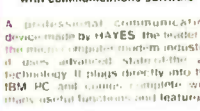

MICROFAZERS by Quadram

PRINT BUFFERS

Please call for prices on the configuration of your choice.



EAGLE COMPUTER

PLEASE CALL FOR DETAILS ON OUR EAGLE Ie AND EAGLE PC SYSTEMS



COMMODORE 64

CALL FOR PRICE
COMMODORE 1541 Disk Drive Call 289**
COMMODORE 1525 Printer 65**
Database program generator 229**
DATA 20 Z 80 & 80 column pac 229**
CARDCO Centronics interface 65**
Micro System RS 232 interface 59**

We carry a complete line of accessories and software for the Commodore. Please Call

CALL FOR ATARI TOO!



corona.

IBM PC COMPATIBLE DESKTOP COMPUTER

128K, dual 320K disk drives, 9" display, serial & parallel ports, and MS-DOS.

IBM PC COMPATIBLE PORTABLE

128K dual 320K disk drives, 9" display, serial & parallel ports, and MS-DOS. Please call or write for more details.



QUADLINK

by Quadram

Only \$499.95

Now you can run Apple software on your IBM PC. Advanced technology from the IBM PC peripheral leader Quadram has made it possible. Quadlink allows you all IBM enhancements while running Apple software, including all peripherals. Now you can enjoy the best of both software worlds including hires games special packages not available on the IBM PC. Apple/ve your IBM today!

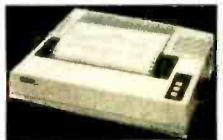

EPSON FX-80

Call for special price

RX-80 Special Price \$339.95

EPSON FX-100
GEMINI 10X Please call for low prices
GEMINI 15
C.I.TOH 8510
C.I.TOH 9550
NEC 3023A
BROTHER HR-1
CANON A210 INK JET
TRANSTAR



OKIDATA ML92

160 cps, 10" carriage, 80 columns

Only \$499.95

Tractor for ML 92	59**
OKIDATA 03	869**
OKIDATA 82A with tractor	459**
OKIDATA 84A par. w/tractor	999**



TRANSTAR 315 COLOR PRINTER

Prints 7 colors plus more than 30 shades, all in a single pass of the print head. And it's built by Seiko

Only \$549.95



LETTER QUALITY PRINTERS

C. I.TOH F-10 Starwriter 40 cps	1149**
C. I.TOH F-10 Starwriter 55 cps	1649**
Daisywriter 40 cps w/4HK buffer	1049**
NEC 3510 33 cps RS 232 serial	1389**
NEC 3530 33 cps parallel	1489**



NEC 3550 Sprinwriter for IBM PC

Only \$1889.95



COLUMBIA VP PORTABLE

Featuring IBM PC and COMPAT compatibility teamed with the most comprehensive software package in the industry to deliver all the functions you need. Includes 128K RAM, expandable to 256K, 2 5 1/4" half-high floppy disk drives with 120K DS/DD & 480K DS/DD drives, character set. Full IBM compatible keyboard. The unit only weighs 32 lbs.

PLEASE CALL FOR MORE DETAILS.



APPLE DISK DRIVES HALF-HEIGHT

SLIMLINE 5 1/4" DRIVES

Overdrive with controller	299**
Overdrive without controller	249**

Fourth Dimension with controller	279**
Fourth Dimension	239**
MicroSci A2	249**
MicroSci A2 with controller	459**
Rana Elite I	289**



FRANKLIN ACE 1200

Apple II compatible computer - 64K, upper/lower case, and more!

FRANKLIN ACE 1000 AVAILABLE. PLEASE CALL FOR DETAILS. System packages at special prices.

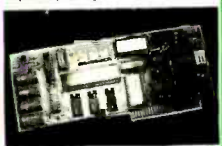

APPLE II ACCESSORIES

Grappler Plus	125**
PKASO Interface	135**
Grappler Bufferboard 16K	139**
Hayes MicroModem II with terminal package	279**
Videx 80 column card	239**
Enhancer II	119**
Ultraliner 128x48 video card	339**
Wizard BPO card	139**

MICROSOFT

PREMIUM SYSTEM

Includes 2.80 SoftCard, 16K Ram Card, Videx Videoterm, Softswitch, & CP/M User Guide by Adam Osborne. List 755.00. Only \$459.95

2.80 SoftCard by Microsoft	229**
16K RamCard by Microsoft	69**



IBM Personal Computer

Includes 64K, 2 DS/DD 320K drives, keyboard, color video card and MS-DOS. PLEASE CALL FOR SYSTEM PRICES.

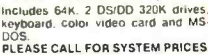

Columbia MPC

IBM PC compatible system. Includes 128K, 2 DS/DD 320K drives, keyboard, video card, MS-DOS & CP/M 86 software. Monitor not included. PLEASE CALL FOR SYSTEM PRICES.



QUADRAM QUADBOARD

256K only \$399.95

64K 269**	128K 349**	192K 419**
-----------	------------	------------

512 QUADBOARD

64K 269** 256K 429** 512K 639**
QuadChrome RGB Color Monitor Call Coming soon! New direct connect modem.



AST MEGAPLUS

64K with serial & clock	339**
128K 399**	192K 449**
64K with parallel & serial	379**
128K 439**	192K 499**
MegaPak option (256K) for 512K total	329**

COMBOPLUS

64K w/tn serial, parallel & clock 339**
128K 399** 192K 459** 256K 499**

IO PLUS

Serial, parallel, clock and game adapter port 155**

Apparat, Inc.

ComboCard with parallel printer port, Asynchronous communications / RS-232 port, and clock/calendar 169**
RS-232 cable for combo card 29**

Frederick/Plantonics COLORPLUS CARD

widra/1sm utility software 369**

DISK DRIVES FOR IBM PC

Tandon TM 100 2 DS/DD	249**
Tandon 5 1/4" Half-Height	CALL
Davong 5 mb	CALL
Davong 10 mb	CALL
Davong 15 mb	CALL

Your Guarantee of Satisfaction
We guarantee every item in this advertisement for 30 days. If, for any reason whatever, you are not satisfied with any merchandise purchased from us, we want you to return it to us at our expense. We will exchange it for exactly what you want, or will refund your money, and include any shipping charges you have paid.

NATIONAL COMPUTER PRODUCTS

To order, please send money order or cashier's check. Personal checks 3 weeks to clear. Prices reflect 2% cash discount. We accept VISA, MasterCard, American Express, Drivers Club and Carte Bancaire. Shipping handling & insurance charges, add 3% of merchandise total (min. \$5.00). California residents add 6% sales tax. Foreign customers please call or write. Prices and availability subject to change without notice. All equipment is new and warranted by the manufacturer.



NATIONAL COMPUTER PRODUCTS

8338 Center Drive, La Mesa, CA 92041-3791

AD #1083



Information on products, and order inquiries call (619) 460-6502

Call, Alaska, & Hawaii Call (619) 698-8088

DEALERS, WE BUY EXCESS STOCK, PLEASE CALL OR WRITE



A FULL CAST OF STAR PERFORMERS

The Esprit product line has the right performer for every terminal role. It begins with *Esprit I*, an editing terminal at a conversational price. This basic Esprit presents crisp, clear video in comfortable green phosphor on a 12" diagonal screen. The integral typewriter keyboard has a 14-key numeric pad with alternate function key modes. *Esprit II* delivers additional editing features, plus the convenience of a detached keyboard; enhancements you'll appreciate in data entry. *Esprit III* meets a wide range of terminal applications. It costs much less than a TVI 925, but gives a significantly stronger performance including line drawing graphics, a broad repertoire of video attributes and editing commands, 22 user definable function keys and an optional 4-page display memory. *Esprit III COLOR* delivers the full Esprit III performance in eight brilliant colors.

There's an Esprit that's ready to star in all your terminal roles. Auditions are being held by your Esprit dealer right now.

Esprit Systems, Inc., Hazeltine Terminals Division, 100 Marcus Drive, Melville, NY 11747 (516) 293-5600

Esprit Systems, Inc.
Hazeltine Terminals Division



Photo 5: The APC nonmaskable interrupt switch. Access to the switch is possible only by removing a rubber plug in the rear of the keyboard.

The keyboard has an undocumented feature. A close look reveals the absence of any CPU reset key. Nor does the main enclosure have such a switch. The only "panic button" evident is the main power switch, which is a poor substitute for a reset. There is nevertheless a hardware reset switch hidden inside the keyboard. (It took me several weeks to realize it was there.) Access to it is possible only by removing the rubber plug on the rear of the keyboard (see photo 5). You can stick a finger inside and press a momentary-contact switch that generates the 8086 nonmaskable interrupt. Unfortunately, unless you have inserted the proper jump vector into low memory, the 8086 jumps to a routine that prints "INTERRUPT TRAP HALT" on the screen and then stops dead in its tracks. The APC then has to be turned off and back on. I would have thought a warm or cold boot of CP/M-86 would have been more useful, but this is better than nothing.

Inside the Main Enclosure

One reason I was especially interested in the APC was because I had learned to associate NECIS with high-quality products. I was not disappointed.

On the outside, the APC has a clean and aesthetically pleasing design. A peek inside the main enclosure (see photo 6) reveals a thick steel chassis that reminds me of the tough insides of NEC's Spinwriter. The top cover securing latches, for example, could have been plastic, but instead they are 1/8-inch steel. The routing of all cables is neat and secure. There is nothing that hints of any last minute changes (except that the red, blue, and green bias pots on the analog board have been replaced by small shorting jumpers).

The two slim 8-inch disk drives to the right of the CRT are NEC's own (FD 1165 S). The six-slot card cage is occupied by three 100-contact circuit boards (not, alas, S-100). One board is the main processor board with the 8086 and 128K bytes of RAM. Another board contains the controllers for the CRT, disk drives, and serial and parallel interfaces, with an empty socket for an optional

8231 arithmetic coprocessor chip. (Rumor has it that NECIS may soon offer the 8087 chip instead.) The third board contains an additional 128K bytes of RAM and the second 7220 GDC with its own 384K bytes of RAM. Adding a second serial controller and the hard-disk controller would take up two more slots on the card cage, leaving only one. But the size of the boards (11 by 9½ inches) allows for a great deal of hardware on one board. You could, for example, get another 384K bytes of RAM (bringing it up to the maximum 640K allowed) on another board and still have room for something else. (A light pen would be nice.)

Documentation

The APC documentation is slick. Pages are typeset and arranged in two small three-ring binders. The *Operator's Guide* gives the user a brief overview of the system, unpacking instructions, etc. The *System Reference Guide* consists of several hundred pages of detailed descriptions of the APC hardware. I was amazed at the amount of information provided. There are even IC (integrated circuit) data sheets for the 8086 processor, the 7220 GDC, the 765 disk controller, and other important chips. (Not included are the data on the 8048 keyboard controller, the 8255A programmable peripheral interface, and the 1771 sound generator.) In addition, there are 22 pages of schematics. Even the PAL (Programmable Array Logic) decoding specifications are provided. Each manual has a table of contents, and the *System Reference Guide* has a glossary.

The CP/M-86 operating system has two other manuals: the *CP/M-86 System User's Guide* and the *CP/M-86 System Reference Guide*. They are typeset versions of Digital Research's manuals, with additions and caveats concerning the APC implementation and APC-specific features such as music generation, user-programmable charac-



Photo 6: Inside the APC (color model). At left are the two 8-inch disk drives. To the right is the ventilation fan. Behind the fan is the six-slot card cage, presently occupied by three boards. To the left of the card cage is the CRT, and behind that is the main analog board.

ters, and so on. These manuals live up to Digital Research's strict requirements for near-completeness amid utter confusion. But a clever reader can often figure out some way to arrange a series of trial-and-error experiments on the computer to discover what the manuals were hinting at. Maybe.

In the text portions of the four manuals, I found only five typographical errors. The tables and drawings, however, were another matter. At last count there were 76 errors, most of them minor, but some of them the source of a great deal of confusion and wasted time.

An optional *Maintenance Guide* includes data not provided in the *System Reference Guide*, most notably a trouble-shooting guide, schematics for the analog board, and several pages of illustrated parts breakdowns. The trouble-shooting guide is interesting in that, if a faulty part is located, it instructs you to send the entire subsystem in for replacement. I suspect that this will make field maintenance of the APC a simple matter. Fortunately, my machine has been performing flawlessly from the time I first plugged it in, so I have had no occasion to seek maintenance.

Problems

The APC has some minor annoyances. I mentioned that the keyboard is excellent with one exception—the left Shift key. The key cap is about two and a half times wider than usual, which makes finding it with your little finger an easy matter. The cap attaches to the switch underneath by means of a shaft that comes down from the left edge of the cap. Unfortunately, a typist's fast-moving little finger often presses down near the center or the right edge of the cap. This applies torque to the shaft, which then binds—a real nuisance. Fortunately, the key can be unsoldered from the printed-circuit board underneath and moved over to the right (it's as though the keyboard was designed for the key to be soldered into either spot). This solves the problem of the sticking key, but at a slight aesthetic cost: the keycap must now be turned around, and you see Shift printed upside down.

A second problem has to do with the way the CBIOS routines handle the keyboard under CP/M-86. I mentioned before that the Alt key is not decoded to give access to the user-defined characters as it should. In addition, there are certain key strokes which the CBIOS routines will not allow your program to know about. Specifically, the programmable-function keys will always generate their programmed sequence of characters, and CONTROL plus the up- or down-arrow key will always cause the screen to scroll up or down. There is no way to intercept these key codes to take some other action unless you write your own keyboard-decoding routine.

The third problem concerns the display. When a large portion of the screen holds characters in reverse video (or when the graphics have printed over a large area of the screen), there is a flicker to the display. The display also wiggles slightly, although most people probably would not notice it.

Support

What kind of support is the APC owner likely to get from NECIS? Over the past four years I have occasionally dealt with NECIS for servicing of my (second-hand) Spinwriter printer. I have found the company consistently courteous, prompt, and helpful (over the phone, anyway). Although the printer is years out of warranty, they sent me, free of charge, an upgraded main processor board for it, along with a more recent users manual.

Although NECIS wants its APC customers to deal with their dealers and not directly with the head office, the head office seems to be bypassing its dealers and going directly to its customers. I was recently mailed an updated version of the CP/M-86 disk, but my dealer has not received a copy. (The updated version, by the way, provided for a 200 percent speed improvement in certain disk accesses and included Digital Research's GSX-86 graphics-system extension package which provides graphics handling routines allowing programs to talk to a number of graphics devices (CRTs, printers, plotters) in a uniform manner without having to worry about coordinate translations and scaling.)

Several months ago I received a letter from NECIS saying that some users felt the ventilating fan in the color model was too loud. (It is. The fan is a 4½-inch Sanyo that is noisy when the APC is positioned close to a wall that reflects the noise.) The letter said that users will be able to pick up smaller fans from their dealers and install them themselves. How much will this cost the user? Nothing. Moreover, NECIS does not even require the original fan in exchange. Unfortunately, my dealer was not told about these new fans, and even after several months he has still not been able to get any.

In spite of the lack of communication between NECIS's head office and the dealers, I believe that NECIS is taking a continued interest in customer satisfaction. The company distributes a number of software packages for the APC and each package is guaranteed to conform to the specifications supplied with it. (If it doesn't, NECIS will fix it or give you your money back.) Because the software includes database management, accounting, spreadsheet, word-processing, and communication packages, the company's guarantee is a significant indication of its support for the APC.

All of its software, however, must be run under the CP/M-86 operating system. Will NECIS support any high-level language or any other operating system? Yes and no. MS-DOS, the operating system from Microsoft that the IBM Personal Computer has made so popular, is now available for the APC. Getting a copy, however, has been so far impossible. I'll have to wait and see what happens. As for a high-level language from NECIS, there is PTOS BASIC, a BASIC interpreter provided only to dealers for running some graphics demonstration programs. Although no documentation is provided with PTOS BASIC, I did a little experimenting that revealed that it is similar to Microsoft BASIC with almost all the bells and whistles you could imagine and with some

Listing 1: The Sieve of Eratosthenes Benchmark Program written in PTOS BASIC for the NEC APC.

```

5 DEFINT A-Z
10 S=8190
20 DIM F(S)
30 PRINT "10 ITERATIONS"
40 FOR M=1 TO 10
50 C=0:FOR I=1 TO S:F(I)=1:NEXT
60 FOR I=1 TO S:IF F(I)=0 THEN 100
70 P=I+I+3:K=I+P
80 IF K <= S THEN F(K)=0:K=K+P:GOTO 80
90 C=C+1
100 NEXT
110 NEXT
120 PRINT C" PRIMES"
    
```

powerful graphics commands. I hope NECIS chooses to release this BASIC.

To test the speed of the APC, I rewrote the Sieve of Eratosthenes program (see listing 1) in PTOS BASIC. Execution time (10 iterations): 1680 seconds. After removing line 5 (so that variables were single-precision floating point), execution time slowed to 2070 seconds. (The program was adapted from the BASIC version for the program listed in "Eratosthenes Revisited, Once More through the Sieve," January 1983 BYTE, page 283).

The APC is a member of the new generation of high-performance microcomputers. It will not compete in the low-end market dominated by Apple, Atari, Radio Shack, and Commodore. It does, however, represent an option to the IBM PC, but its success as a PC competitor will depend to a large extent on independent hardware and software vendors. There are already dozens of CP/M-86 programs—from business applications to languages to games—available from independent vendors that are written for, or can be customized for, the APC.

The list is too long to include here (NECIS can provide about a 30-page list), but one item is worthy of note: Ticom (13470 Washington Blvd., Marina del Rey, CA 90291) has reportedly adapted the UCSD p-System for the APC and added support for the APC's graphics, music, and clock/calendar features. This opens a whole new range of application software.

It is by now a firm tradition that each brand of computer be supported by some kind of newsletter. An independent APC news journal, *NexWorld* (285 Beach St., Belmont, MA 02178), began publication in April. A slick (and a bit expensive) monthly publication, it is under the editorship of Kenneth T. Mazur.

Conclusion

When I set out on my search for a new-generation microcomputer, I had a checklist of desirable features. The APC fulfilled all my requirements and then some. I am pleased with its quality, design, and power. The high-resolution color graphics are impressive. The manuals supplied with the system contain a great deal of information about the machine's hardware. The problems I've encountered after six months of fairly intimate work with the APC can be classified as minor annoyances. On a scale of 1 to 10, I give the NEC APC a 9. ■

I would like to thank the staff of the Computer Center of Rochester, New York, for their assistance in the preparation of this article.

David B. Suits, assistant professor of Philosophy at the Rochester Institute of Technology, is currently studying for an MS in Computer Science. He has written articles for other microcomputer publications, published the book Color Graphics for Intecolor 3651 and Compucolor II Computers, and is coeditor of Colorcue, a newsletter for Compucolor and Intecolor computer users. He can be reached at the College of Liberal Arts, Rochester Institute of Technology, POB 9887, Rochester, NY 14623.

**FOR YOUR APPLE,
RADIO SHACK,
IBM PC,
OSBORNE ETC.**



DISKETTES-5 1/4 IN.

	3M	COMMAND
SSDD	\$2.10 Ea./50	\$1.90 Ea./80
DSDD	\$2.85 Ea./50	\$2.75 Ea./80

HARD DISC SUBSYSTEMS

	5MB	10MB	15MB
APPLE	\$1325.	\$1525.	\$1725.
IBM	\$1350.	\$1550.	\$1750.

We carry Daisy Wheel Printers, Floppy Disc Drives, Monitors, Terminals, Expansion Boards, Software, Ribbons, Printwheels Etc.

Call Toll Free 1-800-638-2436
We are open on Saturdays: 9:30 AM to 1 PM



Met-Chem International Corporation
2911 Dixwell Avenue Hamden Conn 06518
Telephone (203) 248-3212

Circle 290 on inquiry card.

**5 Megabyte
Winchester Disk
\$375.00**

These are factory new units. Every unit was burned in for more than 48 hours, and then passed final certification. Each unit comes with a 30 day warranty from Software Services. These units are the close-out of a major manufacturer's 1982 product line. This is a one time offer, limited to units on hand.

Product Features:

- 1) 6.4 Megabyte raw capacity
- 2) Standard ST506 interface
- 3) 5.0 mbits per second data transfer
- 4) 1.75 millisecond track to track
- 5) Reliable rack and pinion positioner
- 6) Same profile as 5 1/4-inch floppy

Add \$12.00 shipping and handling per disk drive. Optional faceplate is \$5.00. Product manual alone is \$5.00. Call for quantity prices. Terms are personal check or money order.

Software Services
721 Glenhaven Court
Boulder, CO 80303
(303) 494-1518

Circle 437 on inquiry card.

**SAVE MORE
THAN EVER ON
3M Scotch
DISKETTES!**



\$1.95 ea. 5 1/4" SSDD (744)
Qty. 20

\$2.70 ea. 5 1/4" DSDD (745)
Qty. 20

5 1/4" SSDD—96TPI (746)	\$2.89 ea.
5 1/4" DSDD—96TPI (747)	\$3.95 ea.
(Specify soft, 10 or 16 sector.)	
8" SSDD (740)	\$2.07 ea.
8" SSDD (741)	\$2.54 ea.
8" DSDD (743)	\$3.30 ea.
(Specify soft or 32 sector.)	

Save even more on quantity orders!
Minimum Order: 20 diskettes. Add \$3.00 shipping per 200 diskettes. C.O.D. charge \$1.65 additional.

Visa • MasterCard • Checks
For fast service, call
DISK WORLD!
Nationwide: 1-800-621-6827
In Illinois: 312-944-2788
Suite 4806 • 30 East Huron Street • Chicago, Illinois 60611

Authorized Distributor
Information Processing Products



Circle 156 on inquiry card.

**WE UNLEASH THE
POWERFUL GRAF**



THE WORLD'S MOST REALISTIC TECHNOLOGY.

You'll never see Infocom's graphics on any computer screen. Because there's never been a computer built by man that could handle the images we produce. And, there never will be.

We draw our graphics from the limitless imagery of your imagination—a technology so powerful, it makes any picture

that's ever come out of a screen look like graffiti by comparison. And nobody knows how to unleash your imagination like Infocom.

Through our prose, your imagination makes you part of our stories, in control of what you do and where you go—yet unable to predict or control the course of events. You're confronted with situations and logical puzzles the like of which you won't find elsewhere. And you're immersed in rich environments alive with personalities as real as any you'll meet in the flesh—yet all the more vivid because they're perceived directly by your mind's eye, not through your external senses. The method to this magic? We've found the way to plug our prose right into your psyche, and catapult you into a whole new dimension.

Take some tough critics' words about our words. **SOFTALK**, for example, called **ZORK® III**'s prose

“far more graphic than any depiction yet achieved by an adventure with graphics.” And the **NEW YORK TIMES** saw fit to print that our **DEADLINE™** is “an amazing feat of programming.” Even a journal as video-oriented as **ELECTRONIC GAMES** found Infocom prose to be such an eye-opener, they named one of our games their Best Adventure of 1983.

Better still, bring an Infocom game home with you. Discover firsthand why thousands upon thousands of discriminating game players keep turning everything we write into instantaneous bestsellers.

Step up to Infocom. All words. No graffiti. The secret reaches of your mind are beckoning. A whole new dimension is in there waiting for you.

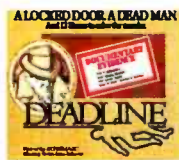

INFOCOM™

The next dimension.

Infocom, Inc., 55 Wheeler St., Cambridge, MA 02138

For your: Apple II, Atari, Commodore 64, CP/M 8*, DEC Rainbow, DEC RT-11, IBM, NEC APC, NEC PC-8000, Osborne, TI Professional, TRS-80 Model I, TRS-80 Model III.

Circle 226 on inquiry card.

Hardware Review



Photo 1: The TRS-80 Model 4 may look like a Model III in a white cabinet, but it is really a new computer. (All photos by Glenn Mead.)

Radio Shack's TRS-80 Model 4

This Model III-compatible computer has a host of new features and a lower price tag than its precursor

by Rowland Archer Jr.

The design of Radio Shack's new TRS-80 Model 4 computer is proof that large corporations can be responsive to the needs of their customers. An enhanced version of the popular TRS-80 Model III, its new features read like a Model III owner's wish list. Highlights include a 24-line by 80-column screen with normal and reverse video, an enhanced keyboard, a 4-MHz Z80A central processor, up to 128K bytes of RAM (random-access read/write memory), the ability to run normal CP/M, and an internal speaker for sound output. The Model

4 can also run any Model III software in a totally compatible mode. I tried hard, but I couldn't find a single piece of Model III software that didn't run perfectly on the Model 4.

Overview

The least expensive Model 4 is the \$999 tape-based version. For \$1699 you can get a Model 4 with one disk drive; most people will probably buy the two-drive system, priced at \$1999. You can start with any model

and upgrade in stages all the way to the top of the line. Separately priced options include 64K bytes of memory for \$149, the first disk drive for \$649, the second disk drive for \$240, and a 5-megabyte Winchester disk drive for \$1999. There is an additional installation charge (not specified) for any upgrade. Radio Shack plans to offer a high-resolution (640 by 240 pixels) monochrome graphics plug-in card for \$249.95.

If you own a Model III, you weren't forgotten. You can upgrade a Model III to a Model 4 for \$799. This may seem expensive, but the upgrade includes a completely new main circuit board and keyboard, lets you run all your old software, and gets you into the new Model 4 world.

The cassette version of the Model 4 looks (photo 1) and acts a lot like a TRS-80 Model III in a white case. It includes 16K bytes of RAM, Microsoft BASIC in ROM (read-only memory), a 16-line by 64-column upper- and lowercase display, a parallel printer port, and a cassette I/O (input/output) port. The keyboard has been upgraded to include a control key, a caps lock key, and three function keys. Those are the only new features that are standard with the cassette-based Model 4. You must add at least one disk drive to get any other Model 4 features, even the internal speaker.

The single-disk system includes the above features plus one 180K-byte single-sided double-density disk drive with 40 tracks. The \$1999, two-drive system also adds an RS-232C serial port.

A disk-based Model 4 is a dual-personality machine. When you run Model III software, it mimics a Model III exactly. But when you boot the TRSDOS 6.0 disk that

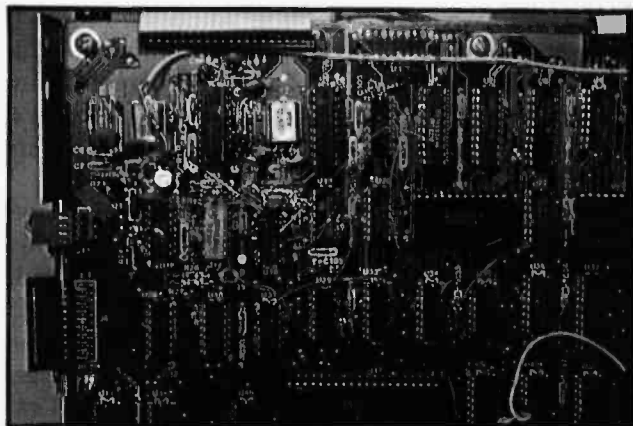

Photo 2: A nest of blue wires bears witness to an engineering staff's last-minute work to get the bugs out of the Model 4.

comes with any disk system or upgrade, the real Model 4 and all of its features emerge. CP/M Plus, an extra-cost option not available at the time of this writing, will also run in Model 4 mode.

Any Model 4 can be upgraded to 128K bytes of RAM. Because the Z80 can address only 64K bytes of memory at a time, the extra memory is switched in and out of the top 32K-byte bank of the Z80's address space. TRSDOS 6.0 software can use the extra memory for a printer spooler or memory disk (more on these later).

Model III Compatibility

When my Model 4 arrived, the first thing on my mind was to check out the claimed Model III compatibility. I

At a Glance

Name

Radio Shack TRS-80 Model 4

Manufacturer

Radio Shack
One Tandy Center
Fort Worth, TX 76102

Price

\$199 (16K bytes of RAM; cassette storage)
\$1699 (64K bytes of RAM; one disk drive)
\$1999 (64K bytes of RAM; two disk drives)
\$149 (additional 64K bytes of RAM, 128K bytes maximum)

Dimensions

18½ by 20½ by 12½ inches
36 lbs. (with two disk drives)

Processor

Z80A running at 2 MHz (Model III mode) or 4 MHz (Model 4 mode)

Memory

16K bytes of RAM minimum, optional 64K bytes or 128K bytes;
14K bytes of ROM (active only in Model III mode)

Data Storage

Cassette in Model III mode; a maximum of four (two in main unit, two external) single-sided double-density floppy-disk drives holding 180K bytes each; a maximum of four 5-megabyte external hard-disk drives may be added

Keyboard

70 keys including control, caps lock, three function keys, and separate numeric data-entry pad

Standard Features

16-line by 64-column display, full ASCII character set, parallel printer port, Model III compatibility on all models; Model 4 mode with 24-line by 80-column display, sound capability on disk-based systems, RS-232C serial port on two-disk systems

Software

Runs all Model III software; all models include Model III ROM BASIC; disk systems include TRSDOS 6.0 and TRSDOS 6.0 BASIC; CP/M Plus optional

Documentation

Getting Started with TRS-80 BASIC, beginner's guide, 342 pp.
Model 4 Disk System Owner's Manual, advanced users loose-leaf reference guide, 500 pp.
Introduction to Your Disk System, TRS-80 Model 4, beginner's guide, 42 pp. All the above include table of contents and index.
Model 4 Quick Reference Guide, TRSDOS 6.0 and BASIC commands, 38 pp.

Audience

Users looking for an expandable system capable of running BASIC and a wide range of Model III TRS-80 and CP/M software

was admittedly skeptical because when the Model III was announced, it was claimed to be compatible with its predecessor, the Model I. There was some truth to this claim, but there were also enough differences to cause most non-BASIC Model I software to require modification before it would run on the Model III.

After unpacking the Model 4 and admiring its off-white, textured plastic case (no tears here for the demise of battleship gray), I plugged it in and booted up a Model III TRSDOS disk. The familiar opening graphics of a Model III appeared, and everything worked OK beginning with the "TRSDOS Ready" prompt. I ran several BASIC programs and found no problems. So far I was not too surprised, because BASIC provides a fair amount of insulation from hardware differences.

Determined to find the cracks in the Model 4's armor, I started running Radio Shack machine-language software. Scripsit, Visicalc, and Profile all checked out OK. Then I ran some non-Radio Shack arcade games—still no problems. Getting desperate, I moved on to self-booting disks such as Powersoft's Super Utility Plus. It came up flying, opening graphics and all. The Model 4 is truly compatible with the Model III.

Part of the key to the Model 4's compatibility with the Model III is the inclusion of a complete set of Model III ROMs, the chips containing Model III BASIC and the Model III I/O driver routines that handle the screen, keyboard, line printer, and cassette port. These chips enable software that makes use of Model III ROM routines to work without changes. The Model III ROMs are located at the beginning of the Z80's address space, in conflict with addresses reserved by CP/M. When you run in Model 4 mode, these ROMs are switched out of the Z80's address space and replaced with RAM. The result is a full-fledged 64K-byte Z80 machine that can run normal CP/M.

Radio Shack deserves a lot of credit for adding so many new features to the Model 4 while retaining total Model III compatibility. The Model 4 user has immediate access to a large range of Model III software and will be able to take advantage of CP/M and TRSDOS 6.0 software as it becomes available.

Screen and Keyboard

The Model 4 has four different screen formats. Two are in Model III mode: 16 lines by 64 columns and a double-width character mode with 32 characters per line. TRSDOS 6.0 automatically switches the screen to a 24-line by 80-column format. Double-width characters, in Model 4 mode, result in 40 characters per line. One annoy-

ance is the need to readjust the brightness when you switch between 16 by 64 and 24 by 80 modes. Apparently the increase in the number of video scan lines to create 24 lines of characters reduces the brightness of each line, making the overall screen image dimmer. When a large solid graphics object is displayed, such as the Tandy hourglass logo that accompanies TRSDOS 6.0 booting, a noticeable hash pattern appears over the graphics image, and bright vertical lines occur where each column meets an adjacent column. This is not a serious deficiency but could benefit from some cleanup work in future revisions of the Model 4. As photo 2 shows, several wiring modifications were made after the PC board was designed, a sure sign that a new PC board is coming soon.

When the Model 4 is in 24 by 80 mode, the video memory is not directly accessible to BASIC programs via PEEK and POKE, as it is in Model III mode. The same physical RAM supports both the 16 by 64 and the 24 by 80 modes, but in the latter mode it is relocated out of directly addressable memory. The Model III graphics character set is available in 24 by 80 mode, and the new larger screen format has higher resolution: 72 by 160 individual pixels in Model 4 mode instead of the Model III's 48 by 128.

The new keyboard (see photo 3) adds several desirable keys to the Model III's layout: a control key (to the left of the space bar, marked CTRL), an uppercase lock key (to the right of the space bar, marked CAPS), and three function keys (over the numeric keypad, marked F1, F2, and F3). With the shift key, the function keys produce six different programmable functions. Keyboards are one of those things that no two people ever seem to agree on, but I think this one has a good feel and is pleasant to use. The control key is somewhat out of the way, down by the space bar, but it is still an improvement over the Model III, which has no control key at all.

The keyboard does not have separate keys to generate some of the less frequently used ASCII (American National Standard Code for Information Interchange) characters, such as braces ({ }) or brackets ([]). These characters can be generated, however, by compound key sequences such as CLEAR plus " < " to generate the left bracket, CLEAR plus " > " to generate the right bracket, and so on. Key sequences are provided for all 128 ASCII characters as well as for most of the high range codes (128 to 255).

TRSDOS lets you turn an audible key click sound on or off during key depression. The sound is very muted and seems to get lost



Photo 3: The Model 4's keyboard enhances the Model III's with a caps lock, control key, and three function keys.

WE'RE LOOKING FOR A FEW GOOD DEALERS.

It's a software jungle out there. You're fighting amidst a deluge of product claims and counterclaims.

That's why you should join forces with the Champion. A superior software accounting system, written in dBASE II* on one small disk, that requires very little dealer support. In fact, Champion performs so well in the trenches that profits are no longer an uphill battle.

The system has received excellent reviews:

"... users will find this to be a very comprehensive software package with several features that make it superior to its competition."

— Carl Heinz, CPA,
INTERFACE AGE, 8/83

Other software dealers will tell you what they *think* their product will do. Only Champion dealers will *show* you how the software performs, feature by feature:

- If you have a question, you can ask the Champion for help.
- The system has built-in safeguards, so it will not crash.
- You get timely, professional-looking reports.
- The entire system is updated whenever any information is entered.

CHAMPION IS EASY TO DEMONSTRATE, SO IT'S EASY TO SELL.

The Champion system is very dealer-friendly. You don't have to be an accountant to demonstrate it. And the system will not crash. Champion gives you total confidence in being able to demonstrate any function to a prospective customer.

After the demonstration, customers can use Champion for a trial period. This allows them to examine the package on their own computers, risk-free for 30 days, or 200 transactions.

See what this system can do for your operations. Be among the few, the proud. The Champion Dealers.

*dBASE II is a registered trademark of Ashton-Tate.

NOTHING PERFORMS LIKE A CHAMPION.

Data Base Research Corporation
66 South Van Gordon,
Suite 155
Lakewood, CO 80228
(303) 987-2588

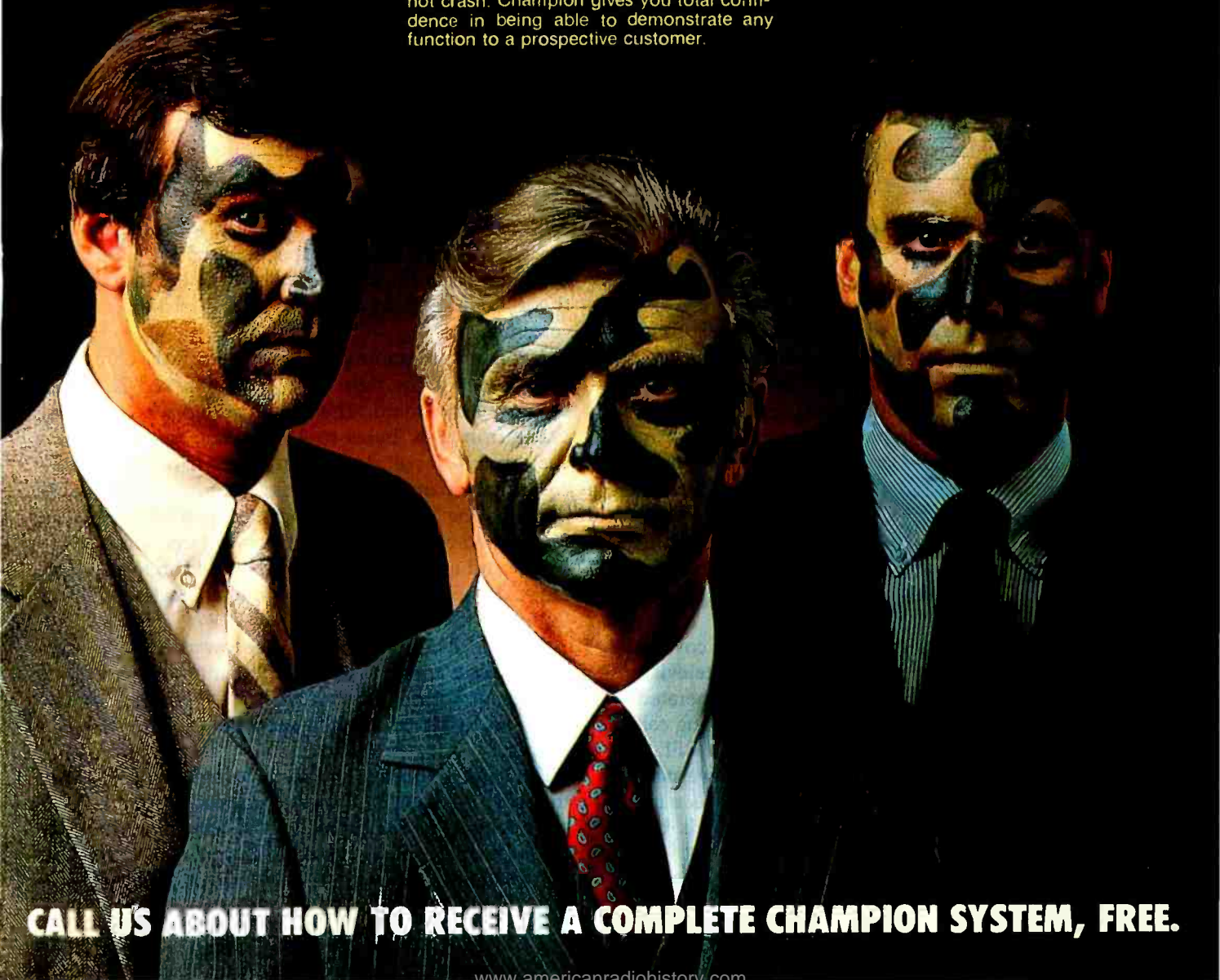

CALL US ABOUT HOW TO RECEIVE A COMPLETE CHAMPION SYSTEM, FREE.

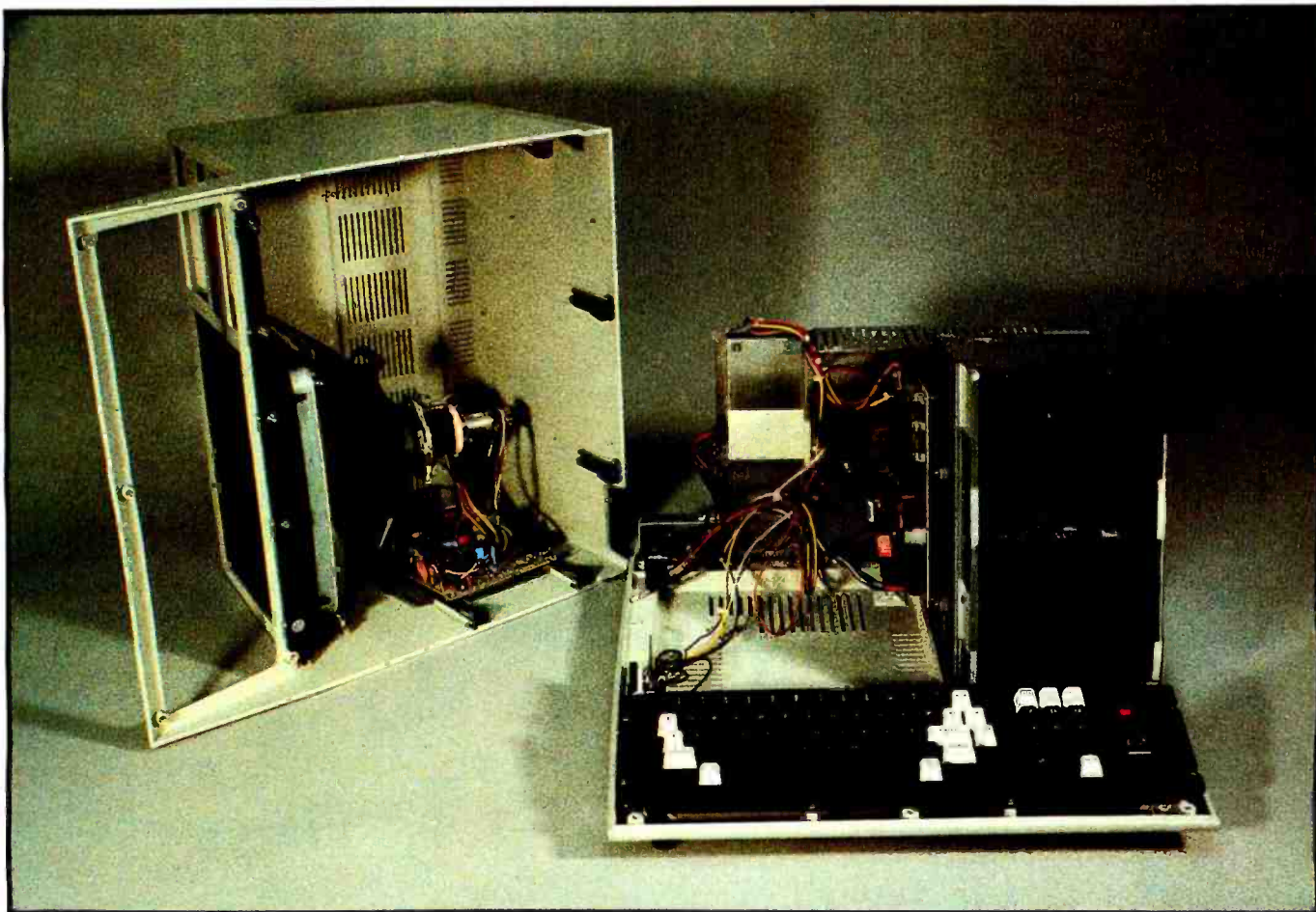

Photo 4: *The Model 4 exposed: the video-display terminal and analog video board are in the top half of the cabinet; everything else resides in the bottom half.*

in the mechanical clatter of key presses, so I left it turned off.

Inside the Model 4

The Model 4's hardware secrets are easily exposed by removing one screw on the back and 10 on the bottom of the case. The video display and analog video board are mounted in the top half of the cabinet, as you can see in photo 4. The bottom half of the cabinet holds most of the Model 4's goodies. Disk-based Model IIIs have two power supplies; the Model 4s have one, mounted vertically to the left of the disk drives. A small board carrying the amplifier and speaker for internal sound is located behind the disk drives. The RS-232C board and the disk controller are also mounted out of sight across the back of the cabinet.

A piece of grounded aluminum completely covers the motherboard, shielding nearby radios and televisions from the radio-frequency interference (RFI) generated by all computer circuitry. All potentially interfering cables are wrapped with aluminum tape to help cut RFI. This shielding pays off; I enjoy listening to shortwave stations while I compute, and my TRS-80 Model I was a horrible broadband polluter. The Model 4's RFI is barely noticeable on a radio in the same room.

Removing the shield exposes the main circuit board

(photo 5). To the lower right, you can see the two banks of eight 64K-bit RAM chips that make up the 128K bytes. The three large chips at the bottom and left of center are the ROMs that hold Model III BASIC and I/O support routines.

A custom programmable array logic (PAL) chip is the second chip to the right of the ROM marked "C" at the bottom of the board. The PAL is added when you upgrade from 64K bytes to 128K bytes; because it is a custom chip, it will slow down alternate vendors of low-cost memory upgrades. The first 40-pin chip above the ROMs is the Z80 central processor; just above it is the 6845 video-controller chip. The two large chips at the center and near the top of the board, from left to right, are video RAM and the custom character-generator ROM.

A tangle of blue wire-wrap wires toward the upper left-hand corner attests to a host of last-minute engineering changes (photo 2). My test machine was serial number 5831, so Radio Shack has been doing a lot of hand-wiring.

The cassette-port connector is located at the back of the machine near the power cord feed-through. Card-edge connectors are exposed at the bottom of the Model 4 for parallel printer, external floppy-disk drive, and master I/O bus connections. RS-232C connection is made

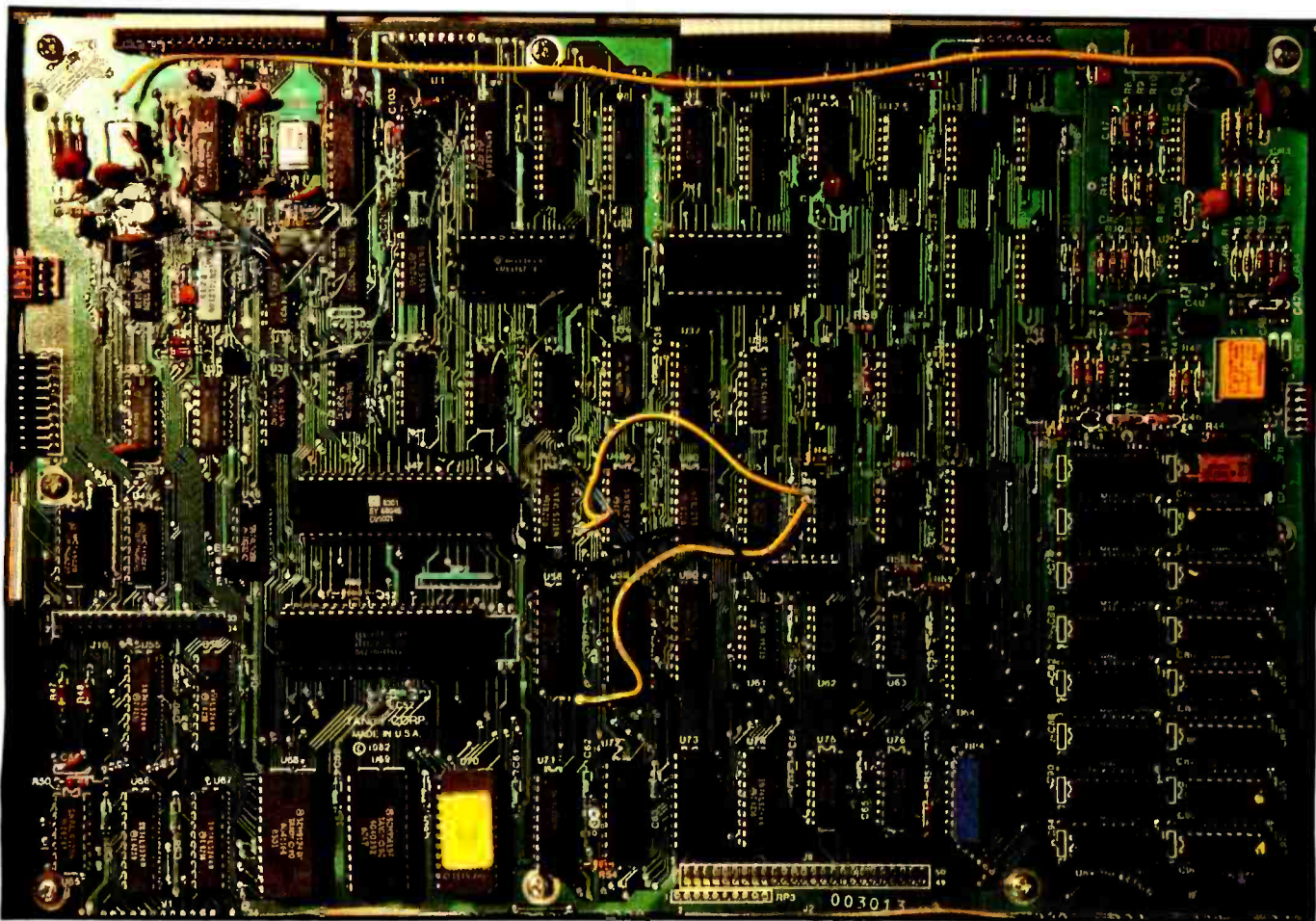

Photo 5: The Model 4's main circuit board. See the text for a tour of its major features.

through a female DB-25 connector on the bottom of the machine.

TRSDOS 6.0

Every disk-based Model 4 computer includes TRSDOS 6.0, which is identical to LDOS 6.00, the latest revision from Logical Systems Inc. LDOS grew out of the original TRSDOS and is largely a superset of it. It should be fairly easy for the experienced TRSDOS user to learn the essentials of TRSDOS 6.0.

TRSDOS 6.0 is totally RAM-based, meaning that it does not use any ROM support code. The Model III ROMs are switched out of the Z80's address space when TRSDOS 6.0 is running. Memory locations 0000 (hexadecimal) to 25FF are used by the resident portion of TRSDOS 6.0. Overlays are mapped from 2600 to 2FFF. User memory starts at 3000, leaving 52K bytes free in a 64K-byte system.

TRSDOS 6.0 can read and write any LDOS formatted disk and convert files from a TRSDOS 1.3 disk. All the powerful features of LDOS are included; see the March 1982 BYTE for a complete review. Suffice it to say here that LDOS is a well-documented, tested, and supported operating system that has sold thousands of copies for more than \$100 each; it is a substantial piece of software to include with the Model 4.

Most of the command syntax of TRSDOS 6.0 is identical to that of LDOS 5.1.3. The following new features are incorporated as well:

- SETKI sets the delay until a key repeats and the rate at which it repeats
- KILL has been replaced by REMOVE, which accepts a list of filenames to delete (TRSDOS 6.0 BASIC still uses the keyword KILL to delete files)
- TAPE100 can read and write Model 100-format cassette tapes, allowing BASIC program and text-file exchange

As mentioned above, the Model 4 can be configured with 128K bytes of RAM. TRSDOS 6.0 includes two programs that take advantage of the extra 64K-byte bank of memory. The first, called MEMDISK, lets you address the extra memory as if it were a disk drive. MEMDISK can also work in a 64K-byte machine, using the available memory you allocate to it. Any files put in a MEMDISK will be accessed at memory speeds, much faster than floppy-disk access times. If you put the TRSDOS system overlay files there, you can make TRSDOS totally memory resident, meaning that you can take the DOS disk out of drive 0 and use that disk drive for a data-storage disk.

The other TRSDOS command that can use the extra

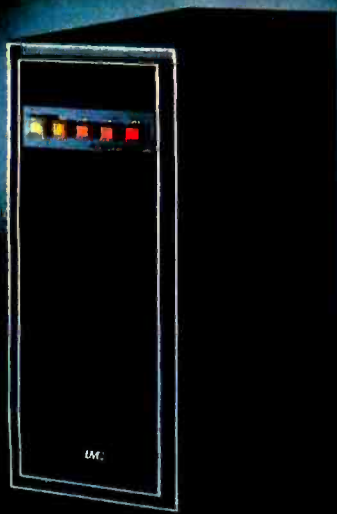

LMC's 32-Bit Virtual Memory MegaMicro Is The-State-Of-The-Art UNIX Microcomputer

LMC's 32-bit MegaMicro provides mainframe or super-minicomputer performance at prices competitive with today's far less powerful 8- and 16-bit microcomputers. This is made possible by use of the next generation of logic chips—the National Semiconductor 16000-series. LMC MegaMicros incorporate: the NS16032 central processing unit which has true 32-bit internal logic and internal data path configured on the IEEE 796 multibus; demand-paged virtual memory implemented in hardware; and hardware 64-bit double-precision floating-point arithmetic.

The LMC MegaMicro is supplied with HCR's UNITY* which is a full implementation of UNIX** and includes the Berkeley 4.1 enhancements to take advantage of demand-paged virtual memory. Also included are C and FORTRAN. Typical multi-user systems with 20 megs. of fast (30 ms. average access time) winchester disk storage, a half meg. of RAM, virtual memory, hardware floating-point arithmetic, UNIX, C, and FORTRAN 77 are available for \$15,000 (and even less with quantity or OEM discounts).

* UNITY is a Trademark of Human Computing Resources.

**UNIX is a Trademark of Bell Laboratories.

LMC MegaMicros *The Logical Alternative™*

LMC

The Logical MicroComputer Company

140 S. Dearborn, Chicago, IL 60603 (312) 580.0250

memory is SPOOL. Like MEMDISK, SPOOL can use available memory (and disk space) in a 64K-byte machine. The most common use of SPOOL is a printer spooler. Output destined for the printer is buffered in memory and sent to the printer whenever it is ready to accept characters to print. As long as your program's printer output does not exceed available memory, it can proceed without having to wait for the printer. For example, you can print a file from TRSDOS, then do other things while it is printing. Although the spooler worked fine from TRSDOS, the version I tested had a problem interacting with BASIC: BASIC generated an internal error whenever I tried to print using the spooler.

For assembly-language programmers, TRSDOS 6.0 has one major difference from TRSDOS 1.3: the use of "supervisor calls" (SVCs), instead of vector addresses, to call DOS routines. SVCs tie down less memory than vector addresses because one address is called with a function number in the A register instead of calling a different address for each function. The Model III's DOS vector table was located above the ROMs, putting it in the middle of user program space on the all-RAM-based Model 4. As a result, any machine-language program that used TRSDOS 1.3 vectors to perform I/O or handle interrupts will not function under TRSDOS 6.0 until it has been changed to use SVCs. LDOS 5.1.3 supported both vector addresses and SVCs, and the manual warned that the use of SVCs was recommended for compatibility with future releases of LDOS. Vendors that took this warning seriously will have the easiest time converting to TRSDOS 6.0.

TRSDOS 6.0 BASIC

Model 4 disk systems also include a new Microsoft BASIC. Although Model 4 BASIC is largely compatible with Model III BASIC, enough differences exist that many programs will require conversion to run in Model 4 mode. The differences are as follows:

- The first 40 characters of variable names are significant; Model III BASIC supported only two significant characters
- Spaces are required between keywords and variables; Model III BASIC allowed them to be omitted in many places
- Floating-point numbers are rounded instead of truncated when they are converted to integers; e.g., PRINT TAB (X), where X is 7.5, prints in column 8 under TRSDOS 6.0 BASIC; it prints at column 7 under Model III BASIC
- ERR is the actual error number, not ERR/2+1
- POINT, SET, and RESET are gone: you can only PRINT graphics characters, and there is no way to PEEK or POKE to the screen
- If a FOR. . .NEXT loop test fails before the first time through the loop, the loop is skipped altogether; Model III BASIC always performs the loop at least once

The entire set of CMD functions (CMD "A" through CMD "Z") is gone; many of the functions have been

DYNAMITE



The Dynax DX-15 explodes into the eighties as the most advanced letter-quality printer on the market today. Complete with all the sophisticated features found in your costlier models, and offering such options as Key Board, Tractor Feed, and Auto Cut Sheet Feed, the DX-15 assures the user, whether it be for business, home or word processing applications, the ultimate in reliability and durability at a blow-away price.

The DX-15 won't blow your budget either, but it will blow the myth that a printer with all these advanced features has to be expensive. Visit or call your nearest dealer for full particulars and let us blow your mind at how inexpensive it is to put you behind the printer of the eighties, the Dynax DX-15... **It's Dynamite.**

Dynax

DYNAX INC. 5698 Bandini Blvd., Bell, California 90201

replaced by new ones with different syntax, e.g., SYSTEM instead of the old CMD "S" command returns you to TRSDOS Ready. There are no replacements for the following functions, however: CMD "C" (compress a BASIC program), CMD "J" (Julian date conversion), CMD "O" (string array sort), and CMD "X" (program cross-reference).

TRSDOS 6.0 BASIC has quite a few new features:

- WHILE. . . WEND loop control
- OPTION BASE selects array origin as 0 or 1
- COMMON stores variable values when CHAINing between BASIC programs
- SWAP exchanges the values of two variables in a single statement
- ERASE removes arrays during program execution
- WAIT suspends execution until a given value is seen at a Z80 port
- WRITE # automatically supplies double quotes and commas when writing strings to a file
- PRINT @ takes either a linear screen position or a row, column location to position the cursor before printing
- WIDTH sets the output line width on either the video display or printer
- CALL augments USR with the ability to call assembly-language routines and pass more parameters
- HEX\$ converts integers to hexadecimal ASCII strings
- OCT\$ converts integers to octal ASCII strings

- LPOS returns the current line printer output column position
- CLEAR sets the high memory pointer and reserves stack space. CLEAR is no longer needed to reserve string space; strings use available memory dynamically
- SYSTEM("command") executes a TRSDOS command and returns to BASIC

TRSDOS 6.0 BASIC is a more powerful BASIC in many ways than Model III BASIC, but it will require program conversion to make use of those features. Fortunately, Model III BASIC will also run on the Model 4, so you can run your old applications without rewriting them.

Documentation

Model 4 disk systems come with one old and three new manuals. The old one is the Model I and III introductory BASIC manual, *Getting Started with TRS-80 BASIC*, a tutorial that is written in a light, entertaining style without being condescending. It follows the tradition of the highly commended Level I BASIC manual written by David Lien. Examples abound, and lots of tips and techniques are highlighted in the margins. I wish this manual had been around when I learned BASIC.

The new manuals are a tutorial introduction to Model 4 disk systems, a large TRSDOS 6.0 and TRSDOS 6.0 BASIC reference manual, and a quick reference guide. *Introduction to Your Disk System* takes the new user step by step from plugging the computer in through running

PRICE, SERVICE, INTEGRITY... YOU OWE IT TO YOURSELF TO CALL US!

TOLL-FREE (800)392-7081
Calif., Alaska, Hawaii & all info Call (213)725-3080



EPSON
FX-80, 160 CPS, 80 Col., friction & tractor feed, parallel... Call
FX-100, 160 CPS, 132 Col., friction & tractor feed, parallel... Call
MX-80, MX-80 F.T., MX-100... Call

FINGER PRINT by Dresselhaus - Add-On module for MX-80/MX-100. Gives fingertip control up to 11 printer functions. Reg. \$59... \$49.95

STAR GEMINI
Gemini-10X 120 CPS, 9x9 hi res. graphic, friction/tractor feed, 80 column, Parallel interface... SCALL
Gemini-15 15" carriage... SCALL

NEC
NEC 8023A, 100 CPS, 80 Col. \$389
NEC SPINWRITER 3550
NEC's new letter-quality printer especially designed for the IBM PC. 203 columns, auto proportional space, justification, bi-directional, 350 words per min. Parallel. \$1,815
Tractor... \$245



PROWRITER
C. Itoh ProWriter 851DAP, 120 CPS, 80 col., Graphics, Parallel... \$345
C. Itoh ProWriter-II 1550, 120 CPS, 136 col., 2K buffer, parallel... \$648



Super 5 CP-80 80 CPS, 80 Col., friction & pin feed for 4" to 10" wide paper. Parallel... \$339



BROTHER HR-1A
Letter quality daisywheel printer 16 CPS, bi-directional, friction feed, Parallel interface. Super value \$595
Serial Interface... \$749
Tractor... \$119

DAISYWRIter 2000
The intelligent letter-quality printer w/48K built-in buffer memory, 17 CPS, bi-directional, auto margin justification, universal interfaces \$1,195

JUKI 6100
NEW! Letter quality daisywheel printer. Features an 18 CPS speed, 10/12/15 pitches, 100-character daisywheel, 13" platen, a graphic mode & word processing functions. 2K buffer, 62dB quiet operation. It utilizes the popular IBM Selectric typewriter ribbons. Parallel... Call



C. Itoh F-10 StarWriter
40 CPS daisywheel (parallel) \$1,089
65 CPS daisywheel (parallel) \$1,499
Tractor for F-10... \$226

DYNAX DX-15
New! Letter quality daisywheel printer with 2-color printing. Logic seeking, bi-directional, proportional spacing, graphic & bold printing, 3K buffer, Parallel... \$CAll
Serial Interface... \$CAll
Cut sheet feeder... \$249
Tractor... \$119
Keyboard... \$195
Ribbons (1 dozen)... \$49



Hayes Smart Modem
300...\$199
1200...\$499
1200B...\$459

MONITOR SALE

**** RGB COLOR ****
BMC BM-AU9191MU, 13" RGB color, 640-dot high resolution. Designed for IBM PC. Sale \$519
Princeton HX-12, 12" RGB color, 690-dot hi resolution. Sale \$485
Amdak RGB Color II, 13", 560-dot, 20 MHz. Sale \$539

**** GREEN SCREEN ****
Dynax GM-120, 12" green, 600 line, 20 MHz. Made by JVC. Excellent! List \$200.00... \$129.00
USI PI-2, 12" green, 1,000 line, 20 MHz... \$159.00
Taxan KG-12N, 12" green 800-dot, List \$199.00... \$149.99

**** AMBER SCREEN ****
Dynax AM121, 12" amber, 600-dot, 20 MHz. Made by JVC. Excellent! List \$250.00... \$149.00
Taxan KA12N, 12" amber 800-dot, List \$205.00... \$150.00
USI PI-3, 12" amber, 1,000 line, 20 MHz... \$179.00

IBM PC & XT

A. 64K IBM PC System, two 320K drives, color graphics card-SCall
B. 64K IBM PC System, two 320K drives, monochrome display, display & printer adapter -SCall

CORONA COMPUTERS
Complete with 128K memory, keyboard, hi-res monitor, graphics, serial & parallel interfaces, MS DOS, GW Basic, PC Tutor, GSX Graphics, Word Processing Software.
Desk Model w/ 2-320K drive SCall

SOFTWARE FOR IBM PC
WordStar... \$495 \$319
MailMerge... \$250 \$169
SpellStar... \$250 \$169
Home Accountant Plus... \$150 \$109
1st Class Mail... \$125 \$99
Multiplan... \$275 \$199
1-2-3 (Req. DS drive)... \$495 \$319
dBASE II... \$700 \$429
Bottom Line Straight... \$400 \$259
Real Estate Analyzer... \$250 \$189
SuperCalc II... \$295 \$139
SuperCalc II... \$295 \$139
Spell Guard... \$195 \$159
Super Writer... \$295 \$229
Versaform... \$389 \$249
PeachPak IGL(A/R/AP)... \$595 \$359
The Tax Manager... \$250 \$179
Property Management... \$400 \$259
VisiCalc/256K... \$250 \$179
VisiFile... \$300 \$219
VisiDisk... \$250 \$199
VisiWord... \$375 \$295
VisiMail... \$225 \$195
VisiSchedule... \$300 \$225
DeskTop Plan... \$300 \$229

HALF HEIGHT DISK DRIVES
for Apple II and Franklin Ace
Super 5 (ALPS) 40-track, SS... \$239
Super 5 (Teac) 40-track, SS... \$269
Super 5 (Teac) double sided... \$365
Control card for SS drive... \$59
Control card for DS drive... \$69

CABLES
Parallel printer cable for IBM PC... \$35
Serial modern/cable for IBM PC... \$35

AST Multi-Function Cards for IBM PC and XT
New Low Prices!
(Each card now comes w/ SuperDrive & SuperSpool)
Amount of memory installed on card... \$4K 128K 192K 256K
with all options (serial, parallel ports & clock)... \$287 337 387 437

SixPakPlus II Cards
Six-function card with 64K-384K RAM memory, Parallel port, Serial port, Optional Game port, Clock-Calendar, SuperDrive & SuperSpool Software. Memory installed on card... \$4K 128K 192K 256K 320K 384K
w/ Parallel, Serial ports & clock... \$359 \$409 \$459 \$509 \$559 \$609
Optional Game port... add \$35

MegaPlus II Cards
Amount of memory installed on card... \$4K 128K 192K 256K
w/ standard features of serial port No. 1 & clock... \$289 \$339 \$389 \$439
w/ either parallel or additional serial port No. 2... \$324 \$374 \$424 \$474
w/ both parallel and additional serial port No. 2... \$359 \$409 \$459 \$509
MegaPak - expands a fully populated MegaPlus card to 612K... \$335

I/O Plus II Cards
Standard card w/one serial port (S1) and clock/calendar... \$129
Additional Parallel (P), Game (G), or Serial 2 (S2) port... add \$35 ea.

5 1/4" DISK DRIVES for IBM PC

Tandon TM-100-1 SSDD 160K \$195
Tandon TM-100-2, DSDD 320K \$245
Tandon half height DSDD 320K \$255
QUME half height DSDD 320K \$249
Panasonic half ht. DSDD 320K \$249

EASTERN ENTERPRISES, INC.
Must Merchandising Since 1969
2937 S. VAIL AVE., LOS ANGELES, CALIF. 90040

To order, please send money order or cashier's check. Personal or company checks require 2-3 weeks to clear. Prices reflect 3% cash discount. Visa/Mastercard accepted. Shipping, insurance & handling charges are 3% of total order value by UPS Surface, 5% by UPS Air or Parcel Post. COD's requires 20% deposit. Calif. residents add sales tax. No sales tax on out-of-state orders. Prices & availability subject to change without notice.

Don't limit your computer's input with a mouse. A mouse can move a cursor on a screen. Period. With GTCO's new Micro Digi-Pad™ you can position a screen cursor...or draw, trace, select menu functions on the tablet, even use the stylus like a joystick. Micro Digi-Pad is priced like a mouse...and you can use it like a mouse. Or use it with a stylus for input as natural as a pencil on paper.

GTCO's patented digital electromagnetic scanning--with no mechanical parts--lends itself to operation in office and industrial environments that cripple an optical or mechanical mouse.

The Micro Digi-Pad is GTCO's answer to the need for low cost, versatile graphic input.

MICRO DIGI-PAD CHALLENGES THE MOUSE



COMPARE

FEATURE	MICRO DIGI-PAD	vs.	MOUSE
Low cost	Yes		Yes
Small Package	Yes		Yes
Ergonomic	Yes		Yes
Low Power	Yes		Yes
Single Voltage	Yes		No (RS-232C Model)
Absolute Coordinates	Yes		No
Off Screen Menu	Yes		No
Trace Graphics	Yes		No
Stylus Option	Yes		No
4D (Stylus tilt output)*	Yes		No
4 buttons	Yes		No
Digitizer Compatible	Yes		No
Dual RS-232C	Yes		No
Hostile Environment	Yes		No
Proven Supplier	Yes		?

*Patent Pending

GTCO is the largest supplier of electromagnetic digitizers worldwide.



GTCO Corporation

1055 First Street/Rockville, MD 20850
(301) 279-9550 Telex 898471

BASIC application programs. A sample mailing-list program, written in BASIC, is supplied with TRSDOS 6.0. Chapter 4 takes you through the process of loading and running the program. Even though this is a small manual (42 pages), it thoughtfully includes an index.

The *Model 4 Disk System Owner's Manual*, based on the LDOS manual, is a large, loose-leaf volume containing both TRSDOS 6.0 and TRSDOS 6.0 BASIC documentation. Each command is described in detail and many examples are given. Written for the programmer, this manual is quite a step up from the introductory booklet. The LDOS technical reference section is not included here; I hope it will be in the promised technical reference manual. Those who need to interface to TRSDOS 6.0 through SVC calls should consult with LDOS 5.1.3 documentation until the technical reference manual becomes available.

The BASIC section of the manual is similar in layout and style to the TRSDOS part. A good understanding of BASIC programming is assumed, and the novice had better work through the *Getting Started* manual before tackling this one. There are a number of appendixes, including a glossary, error message discussion, a list of differences between Model III and TRSDOS 6.0 BASIC, and several on TRSDOS 6.0 programming techniques such as the use of logical devices and filters. The manual closes with a fairly complete index. This manual will require a lot of study on the part of a new user, while ex-

perienced LDOS users should have little trouble.

The *Quick Reference Guide's* 33 pages include an alphabetical listing of TRSDOS 6.0 and TRSDOS 6.0 BASIC commands, statements, and functions. Each command's syntax is given, followed by a one-sentence description and one or two examples. I found the quick reference very helpful once I had learned a command, but not very useful for learning new commands.

Conclusion

The TRS-80 Model 4 provides a lot of flexible computing power. It incorporates many of the most frequently requested enhancements to the Model III. Although a very large library of Model III software already exists, the lack of Model 4 mode software at the time of this review made me feel as if I was driving a sports car that was rigged to keep it from going over 55 MPH. By the time you read this, plenty of CP/M and at least some basic TRSDOS 6.0 software packages should be available.

Given all the new features in the TRS-80 Model 4 and a price that's lower than its predecessor, the popular Model III, it's safe to say that Radio Shack has a guaranteed winner. ■

Rowland Archer Jr. (5420 Loyal Place, Durham, NC 27713) is manager of software development for a minicomputer company. He has been working with TRS-80s for four years.

COMING SOON TO A DEALER NEAR YOU!

CONTROL/NET

(A TRUE STORY)



"A BRILLIANT DEBUT PERFORMANCE"

STARRING—The Control/Net as itself (1 to 10 users, 127 MB hard disk (20 & 40 MB OPT.) TurboDOS™ driven, S-100 bus)

CO-STARRING—Select Wordprocessing™, SuperCalc™ & Tabsort™ 7 module accounting package.

SPECIAL GUEST ... YOU (the Businessperson) in one week of training near Orlando, Florida (home of Walt Disney World & EPCOT center).

All of this for only \$58. per week!

SUPPORTING ROLE played by General Electric's Nationwide optional service contract.



CONTROL
ELECTRONICS
INC.

707 NICOLET AVE. WINTER PARK, FLORIDA 32789 (305) 628-3850

TurboDOS is a trademark of Software 2000. SuperCalc is a trademark of Sorcim, Inc. Select is a trademark of Select Information

THE PURCHASING AGENT works for you!

Here's how we work:

- As your agent, we buy microcomputer products for you from wholesalers.
- We can buy any microcomputer product.
- We are not biased in favor of any particular product or line, because we do not have any stock we need to move.
- Our price policy is to match the lowest legitimate advertised prices, with few exceptions.
- Our service is available to everyone on the same terms:
Prepayment by cashiers check
Freight charges f.o.b. wholesaler
- Bank references and client references are available.

B-83-10

[Since 1980]



THE
PURCHASING AGENT, INC.

574 Weddell Drive, Ste. 5
Sunnyvale, CA 94089
(408) 744-0646

IF YOUR DATA'S WORTH REMEMBERING, IT'S WORTH PROTECTING.

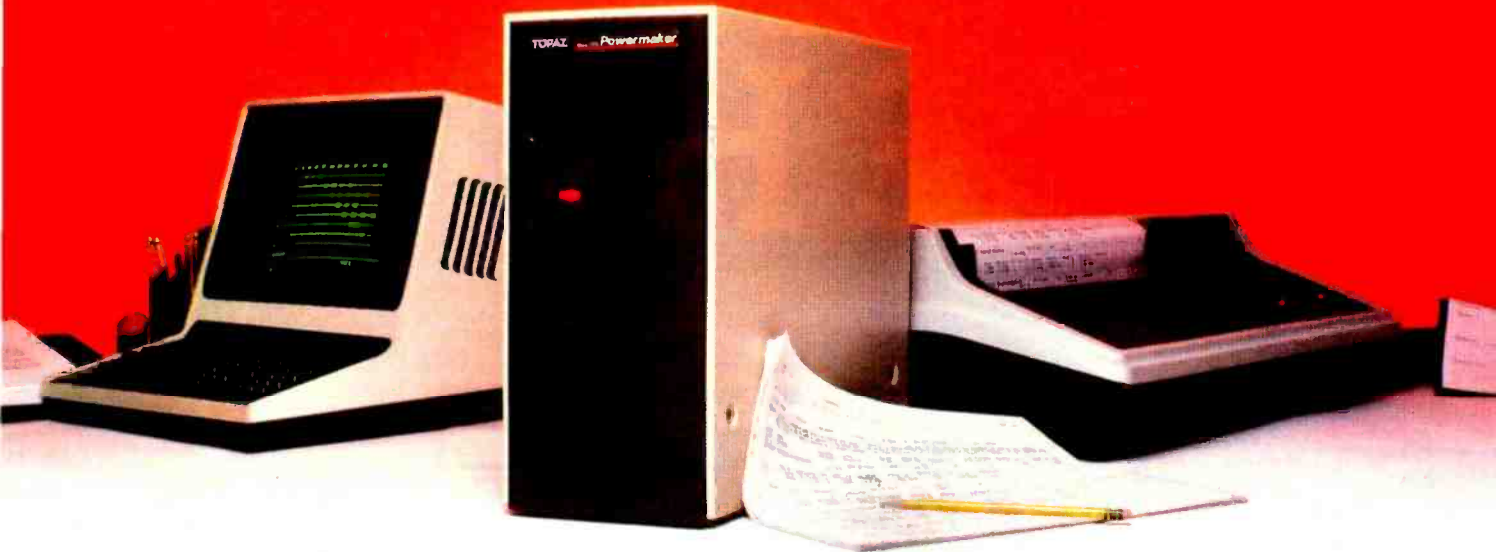

POWERMAKER[®] MICRO UPS

A split-second blackout or a sudden voltage sag can shut down your small business computer, completely wiping out critical data. Inventories, payrolls, receivables — whatever is in the memory may be lost instantly.

Although this type of data is just as important to a small business as it is to a large corporation, blackout protection has always been far too costly for small business applications. But now there is the Powermaker Micro UPS, an inexpensive standby power source specifically designed for small business computers.

This new rechargeable power system provides up to 35 minutes of steady sine-wave power, enabling even the most sensitive small computers to ride through blackouts and voltage sags completely unaffected.

Why sine-wave power? Because square-wave power impairs the performance of many printers, viewing screens and timing circuits. Powermaker produces a sine wave that exactly matches the wave shape of commercial power,

ensuring compatibility with any computer system.

In addition to providing highly reliable blackout and brownout protection, Powermaker also protects against electrical noise, one of the major causes of computer errors and system malfunction. Powermaker is portable, completely automatic, maintenance free and plugs into any standard 120V outlet.

No matter how small your computer, your data is worth remembering. Protect it with an affordable Powermaker Micro UPS.

For complete information about the new Topaz Powermaker Micro UPS, please fill out this coupon or call us.

**TOPAZ; 9192 TOPAZ WAY
SAN DIEGO, CA 92123-1165
PHONE: (619) 279-0831
TWX: (910) 335-1526**

- Please send me complete information about Powermaker[®]
 Please have a representative call me.

Name _____

Title _____

Company _____

Address _____

City _____ State _____

Zip _____ Phone _____

TOPAZ
SOLUTIONS TO POWER PROBLEMS™

THE CORONA PC'STM ARE HERE.

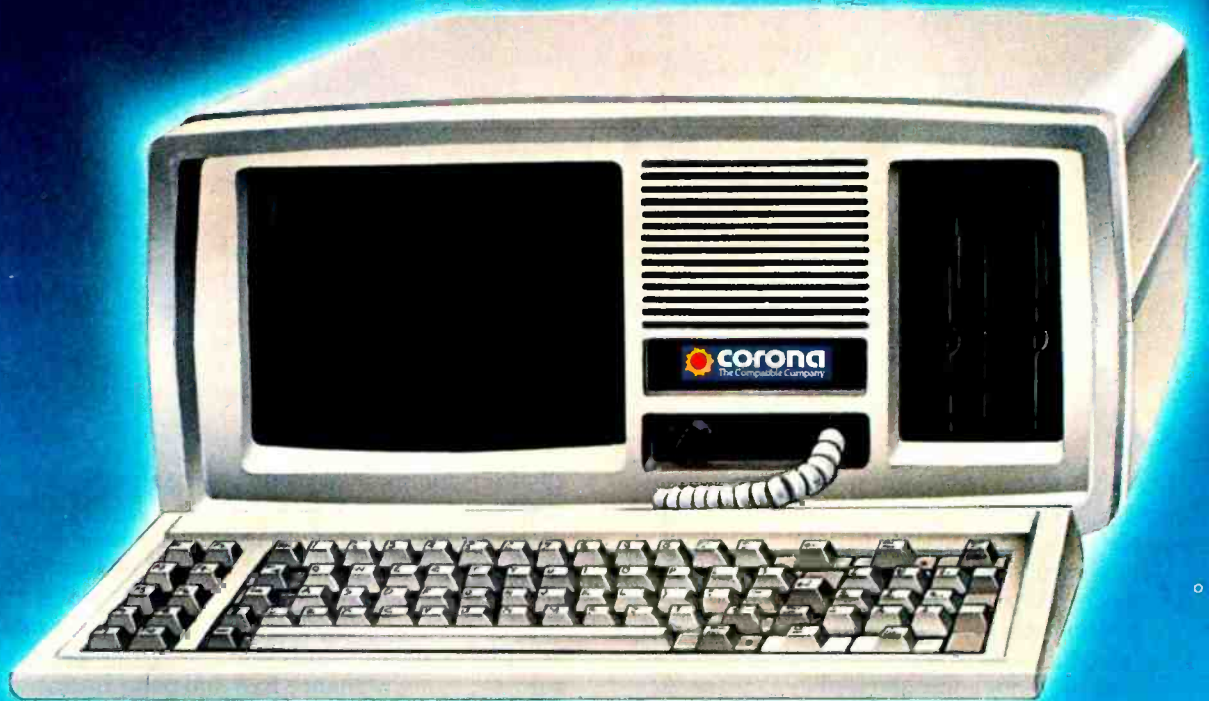

The Corona PC's, desktop and portable, give you everything you've ever wanted in an IBM-compatible PC and more. For a great deal less.

Compatible and more.

The Corona PC is a 16-bit microcomputer based on the 8088 microprocessor, just like the IBM PC. And like the IBM PC, it runs any software that conforms to the IBM standard.

But unlike the IBM PC, the Corona PC comes with 128K of memory. Supports up to 512K on the main board. Includes a 320K floppy drive, a communication port, a printer port and an improved IBM PC keyboard.

Both the desktop and portable Corona PC's include high-resolution monitors and built-in graphics. Higher character definition makes both models easier to read, and our 640 x 325 pixel high-resolution graphics are over 60% better than the

IBM PC. It's a complete system, the standard for microcomputing in the IBM-compatible world.

You can take it with you.

And unlike IBM, we have a portable version.

Its high-resolution, high-contrast 9" display is easy to read. It has all the power and features of our desktop, but lets you take it to the office next door, across the country or just conveniently tuck it onto a corner of your desk.

More expandability.

You may never add a thing to your Corona PC because we've built in so much capability.

But just in case, we've built all the important components into the main system board, leaving the four expansion slots free. And provided an extra large power supply to support any capabilities you may want to add in the future.



RAM-disk for incredible speed.

Our RAM-disk software lets you treat an area of your computer's memory as if it were a disk drive. So you can copy your programs and data into memory, then watch your work get done faster.

More software.

The Corona PC includes the MS-DOS operating system and comes with GW-BASIC, the MultiMate¹ word processor and the PC Tutor² training course. So you can start being productive immediately.

And you can run Context MBA³, dBASE II⁴, LogiCalc⁵ and LogiQuest⁵, the EasyFamily⁶, Wordstar⁷ and the "Star" family, the SuperWare⁸ series, T.I.M.⁹, the VisiSeries¹⁰ and Perfect Series¹¹ of programs and most other popular software.

And it improves your bottom line.

The Corona Portable PC™ is \$2,545, the desktop

version is \$2,595. Both about a thousand dollars less than the equivalent IBM PC.

For more information, contact Corona Data Systems, 31324 Via Colinas, Westlake Village, CA 91361. (213) 991-1144. Call (800) 621-6746 toll-free.

Or better yet, just grab your hat and head to the nearest Corona PC dealer for a very convincing demonstration.



© Corona Data Systems 1983 1: TM Softword Systems. 2: TM Comprehensive Software Support. 3: TM Context Management Systems. 4: TM Ashton-Tate. 5: TM Software Products International. 6: TM Information Unlimited Software. 7: TM Micropro. 8: TM Sorcim Corp. 9: TM Innovative Software. 10: TM Visicorp. 11: TM Perfect Software Inc.

Circle 538 on inquiry card.

The Morrow Micro Decision

A look at Morrow's first effort at a single-board, stand-alone personal computer

by Tom Wadlow

A new contender has entered the field of midrange computers: the Micro Decision, created by Morrow Designs (see photo 1). Midrange computers bridge the gap between low-cost home computers, such as Sinclair, Radio Shack, and Atari machines, and the more expensive systems such as IBM's Personal Computer and the various S-100 and professional systems. The hallmarks of this breed are a large software library (included in the price of the machine) and a price that is always under \$2000.

The midrange category was opened by the Osborne 1 and its close rival, the Kaypro II. The Micro Decision is similar to both these systems and should be a direct competitor with them.

Morrow Designs and its founder, George Morrow, have been in the microcomputer industry for almost as long as the industry has existed. Morrow is known primarily for his work in the area of high-quality S-100 components and systems. The Micro Decision is his first effort in the single-board, stand-alone personal computer market. It is based, in part, on the Decision I, an S-100-based system that is currently Morrow's mainstay.

System Overview

The Morrow Micro Decision is composed of a processor unit, including disk drives and input/output ports, and a terminal. The portable system is built around a single circuit board containing a Zilog Z80A microprocessor running at 4 MHz, 64K bytes of memory (no other size is available), a floppy-disk-drive controller, and two RS-232C serial ports.

The cabinet, which is similar in design to that of IBM's

Personal Computer, is fairly small and will fit easily on a desk or tabletop. The top of the cabinet is a convenient place for the video display. The keyboard is not attached to the display, allowing the screen to be placed at eye level without making the computer uncomfortable to type at. The computer's Reset button is inconspicuously located at the lower right front corner of the processor unit, under the lip of the cabinet frame, making it impossible to reset the system by bumping the chassis with the keyboard. The power switch is on the back of the cabinet.

The terminal provided with the Micro Decision is a Lear Siegler ADM 20), a two-piece unit with the keyboard connected to the back of the display by a coiled 4-foot cable. Brightness and power controls are located on the front of the display. The keyboard has a numeric keypad and cursor control keys in addition to the alphanumeric keypad.

The basic Micro Decision comes equipped with a single 5¼-inch disk drive that holds approximately 200K bytes of information and software that allows you to read and write disks in Osborne, Xerox, and IBM formats.

Micro Decision Hardware

One of the two serial ports is dedicated for communications with the terminal, and the other can be used as a printer port or for connection to a modem. There is also a connector to allow additional disk drives. Lack of a third port is somewhat annoying, as most people prefer not to disconnect cables to switch between their modem and printer. Fortunately, the terminal is equipped with

an auxiliary serial port, and cable swapping can be avoided by connecting the modem to the second serial port and the printer to the terminal's auxiliary port. Morrow should consider, however, addition of a parallel printer port to leave the second serial line free for the modem. This would allow greater printing speed and a wider choice of printers.

Disk Storage

Unlike the Osborne and Kaypro, which each come equipped with two 5¼-inch disk drives, the Micro Decision basic system has only one. The basic drive is single-sided single-density and stores about 200K bytes. Also available are double-sided double-density drives. Programs distributed with the system allow the user to set drive characteristics so that the Micro Decision can be used to read and write formats other than its own. Currently, programs are available for IBM Personal Computer (CP/M-86, not PC-DOS), Osborne, and Xerox disks.

I reviewed a Micro Decision 3. The differences between systems 1, 2, and 3 are in the type of disk drives that are installed. An MD-1 is a system with a single two-thirds-height 5¼-inch drive, an MD-2 has a pair of two-thirds-height drives, and an MD-3 has between two and

four half-height drives. The MD-1 and MD-2 drives are single-sided, with 200K bytes of storage per drive. The half-height drives for the MD-3 are double-sided with 384K bytes per drive. The drives for all systems are manufactured by Tandon.

Tandon half-height drives are very quiet. I would not hesitate to recommend them for use in a small office, where even the hum of a fan can be annoying. On the same note, the Micro Decision has no cooling fans, so other than the faint, intermittent noise of the disks, the unit is absolutely quiet. All Micro Decision drives spin for a few moments after they have been used and then shut down to preserve the media and the equipment (Tandon drives are also fast). Other pleasing features of the system include the Morrow virtual-drive capability and the rewritten software for the disk controller.

The Micro Decision can have up to four physical drives and any number of virtual drives. For example, if you reference a third drive in a two-drive system (perhaps by performing a "STAT C:"), the BDOS (basic disk operating system) will redefine drive A: as drive C: and ask you to change floppy disks. A reference to drive A: will undo the change, again causing a request for you to swap disks.



Photo 1: The Morrow Micro Decision. The system consists of a single-board computer based on Zilog's Z80 processor, some number of 5¼-inch floppy-disk drives, and a Lear Siegler ADM 20 terminal. At press time, Morrow planned to offer a Freedom terminal with the system instead of the Lear Siegler terminal.

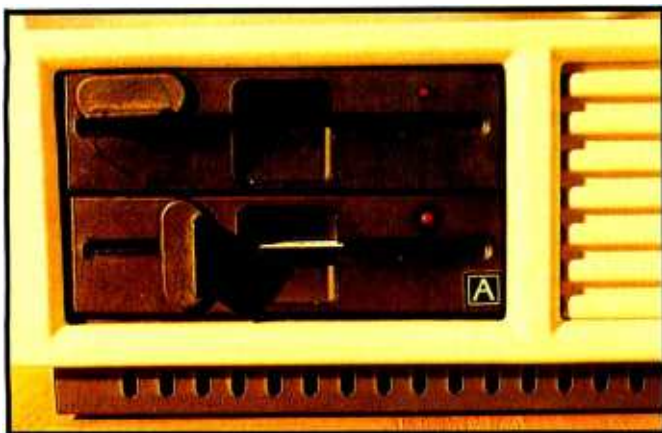

Photo 2: This photo shows the rather odd arrangement used to close the disk drives.

Rewritten software for the disk controller offers the user a choice of responses when faced with CP/M's BDOS error messages. Instead of "BDOS ERROR on B:R/O," the user is now given the option of retrying, aborting the operation, or ignoring the error.

One feature of the system that I did not care for, however, was the knob used to secure the media in the drive (see photo 2). Instead of the usual "garage-door" type latch, these knobs must be turned 90 degrees to close the drive. This is an unnatural motion for most people. But it is a minor inconvenience when considering there are four disk drives in a small enclosure.

The Terminal

My misgivings about this system concern the terminal. I found the keyboard layout poor. For example, the Control key is next to the Space bar, putting it underneath the palm of the left hand; the cursor control keys are in the top row, above the number keys, when there is a numeric keypad that could have doubled as arrow keys (as on many popular terminals); there is a huge Caps-lock key, but a tiny Delete key; and the terminal has an extremely loud and annoying bell tone, with no volume control.

The display, however, is crisp and clear. The terminal has two levels of brightness (an advantage in the menu-driven CP/M provided by Morrow).

Very little information about the terminal comes with the computer. In addition, the terminal is delivered unconfigured. A new Micro Decision user must set the terminal characteristics using a single sheet of instructions and two cursor keys while looking at a baffling row of 1s and 0s that appear at the bottom of the screen. Fortunately, the terminal has a nonvolatile memory, so this setup need only be performed once.

Software

Like the Osborne and the Kaypro, the Micro Decision comes equipped with a basic set of programs, making the computer useful immediately. It also is equipped with a CP/M-compatible screen-oriented text editor, a spreadsheet program, and a database manager.

Morrow PILOT and CP/M: When the Micro Decision's operating system is first loaded, the computer displays a menu of available CP/M commands (see photo 3). This menu is written in PILOT (Programmed Inquiry, Learning or Teaching language), originally designed for writing computer-aided instruction lessons. The menu system provides a clean, simple way to use most of the capabilities of CP/M. Each possibility is described clearly and concisely, with the CP/M command that will be invoked listed with the explanation. Two or three keystrokes will implement almost any command. As each command is executed, the user can watch PILOT invoke the commands from the conventional CP/M prompt. For a novice user, this automated walk-through makes up for the slowness of the menu system because he or she can see the command happening each time. After watching menu commands, the user should gain the confidence and familiarity with CP/M to try the system in the usual interactive manner.

From the menus it is also possible to call each of the packages provided, such as Wordstar and Logicalc. An ambitious user could learn PILOT well enough to add entries to the menu, or perhaps entire new pages containing customized menus.

Logicalc is an interactive spreadsheet program, following the tradition of Visicalc. A spreadsheet calculator consists of an array of cells; each may contain a number, a label, or an equation based on the value of other cells.

At a Glance

Name

Morrow Micro Decision

Use

Personal and general-purpose computing

Manufacturer

Morrow
600 McCormick St.
San Leandro, CA 94577
(800) 521-3493

Size

16.7 by 5.3 by 11.3 inches

Standard Features

Hardware: 4-MHz Z80A processor, 64K bytes of RAM
Software: CP/M 2.2 disk operating system, Wordstar, Correct-It, Logicalc, Microsoft BASIC, North Star-compatible BaZic, Personal Pearl Database

Options

May be ordered with a Lear Siegler ADM 20 video terminal and one or two single-sided disk drives, or two double-sided half-height drives

Price

With one drive: \$1195; with two drives: \$1545; with two half-height drives: \$1695; \$595 for the video terminal

Mass Storage

Up to four 5¼-inch floppy-disk drives

ATTENTION HUMANS! MAGIC HAS LANDED

— the computer for the serious of mind.

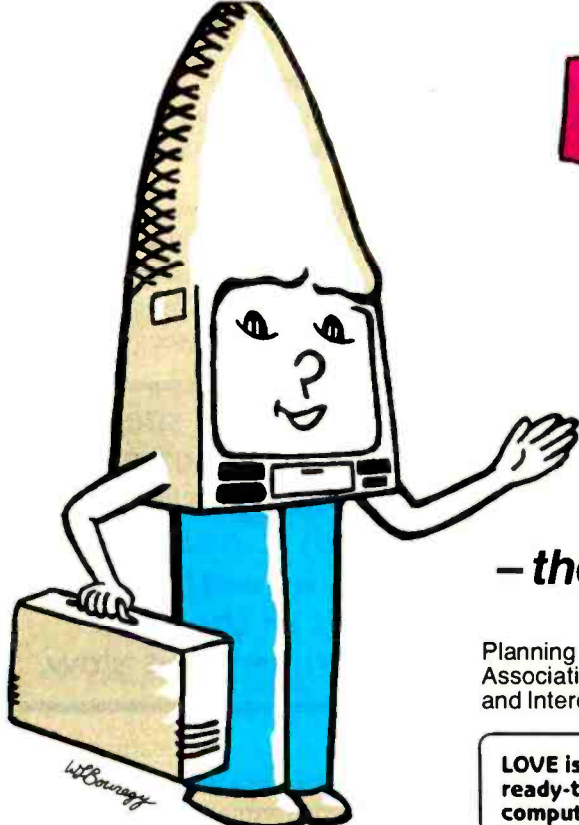

Like television and stereo, computers can be used by many different people, in offices and business, in schools and at home ... the interest in programs is the difference.

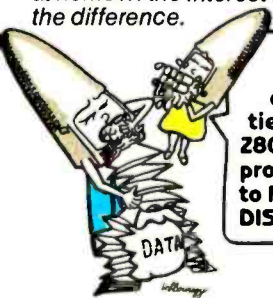

Excessive consumption of mass quantities is EASY with 280A and 6502 processors and up to FOUR 400KB DISK DRIVES.

Here are a few of the ways (or software programs) in which you can put Magic in your life.

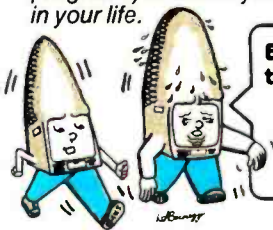

Extensive selection of software abound everywhere at economy levels.

Professional Appointment Book • Income Tax Preparation • Accounts

Receivable • Accounts Payable and Aging • School Administration

• Property and Asset Management • Engineering Circuitry • Sports and Activity Statistics • Medical and Legal Accounting • Wordprocessing and Letters • Travel



64K RAM, dual processor system, video, communications and printer interfaces.

Planning and Scheduling • Church and Association Management • Mortgage and Interest Details •

LOVE is a ready-to-use computer system.



Games for Executives • Menu and Recipe Files • Retail and Store Management • Mail List Operations • Activity and Hobby Organizing • Learning FORTRAN • Order and Sales Entry • Christmas Presents List • College

ATTENTION HUMANS!

Our mission here on earth is rapid conversion of excessive data into functional modes of information ... this may be accomplished with Itty Bitty Machine ... but more productively with MAGIC.

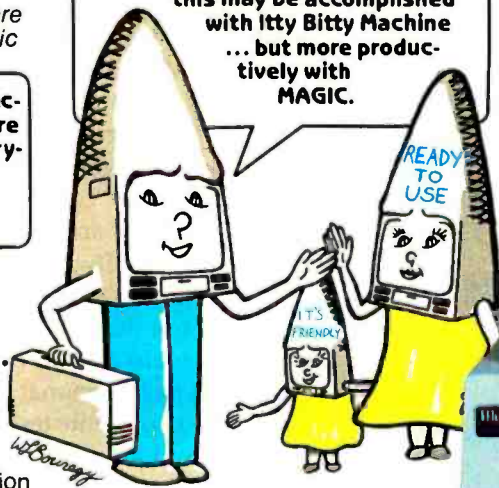

MAGIC speaks many languages including CBASIC which comes with system, plus a dictionary, a word processor, an electronic spreadsheet and a filing system — FREE.

BASIC Programming and Learning • Electronic Spreadsheet • Administrative Reports • Address File, Control and Updating • Dictionary and Spelling • Your Own Private Secretary • Designing Forms • Information for Insurance and Hospitalization • Learning Computers • Managing Home Purchases and Inventory • Structural Engineering • Medical Office Scheduling

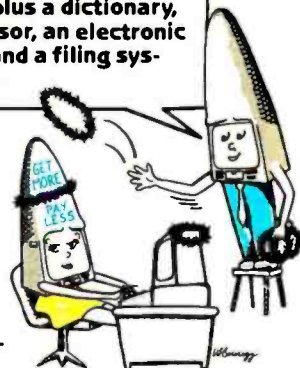

Thesis and Reports • Data Communications • Business Marketing • File and Retrieval Systems • Dental Office Management • Librarianship and Cataloging • Indexing for Small Business • Household Inventory • Investment Analysis and Tracking •



WRITE TO: Magic Computer Company, Inc. • Two Executive Drive • Fort Lee, NJ 07024
(201) 944-6700 • CALL: (800) 221-1565 • Telex: 144594

(3a)

```
THE MICRO DECISION MICRO MENU

This menu is your road map through the CP/M operating system. To
perform these functions, just enter the appropriate number after
the OPTION prompt below, then follow the instructions given.

0  CREATE A WORKING DISKETTE
1  RUN A PROGRAM
2  DISPLAY A DISKETTE DIRECTORY (DIR)
3  VIEW OR PRINT A FILE (TYPE, PIP)
4  COPY A FILE (PIP)
5  FORMAT A DISKETTE (FORMAT)
6  MAKE A BACKUP DISKETTE (FORMAT, BACKUP)
7  CHECK DISKETTE AND FILE SIZE (STAT)
8  OTHER OPTIONS (REN, ERA, STAT)
9  EXECUTE A CP/M COMMAND
ESC  EXIT TO CP/M

OPTION :

Current File:                               Current Drive: A:
```

By changing the value of key cells, it is possible to play the game of "what-if?" Spreadsheets are popular with people who work with a large volume of interrelated numeric calculations.

Logicalc can handle a universe of 255 rows by 127 columns of cells. Of those 32,385 cells, only 10 rows by up to 15 columns are visible at any one time, using the standard display mode. An extended-screen mode is provided that permits a display of 15 rows (see photo 4).

Correct-It is an interactive spelling corrector. Given the name of a text file, it will pass through the file and display words it does not recognize. You can leave the word as is or correct it in the text. Correct-It is well written, but slow.

Logicalc is not as easy to use as Visicalc, creating some problems for novice users, but it does the job. Its major failing in the Micro Decision environment is that it is not integrated well with this computer. Logicalc does not require the use of terminal cursor keys, but rather a group of control characters on the left side of the keyboard. With the inconvenient placement of the Control key, my left hand was cramped during extended Logicalc use. Also, I found the Logicalc installation process confusing.

Another problem with Logicalc is its lack of compatibility with other packages. Although it can save and load spreadsheets, the format of those files is not in the DIF (Data Interchange Format) standard, making it impossible to use Logicalc in conjunction with other popular software on the market. It is, however, compatible with packages written by Software Products International, the authors of Logicalc.

Wordstar and Correct-It: Wordstar is one of the most popular personal computer text editors on the market today. It is a screen-oriented editor that is used as both a word-processing system and in the creation of software.

Correct-It is an interactive spelling corrector written by Aspen Software. Given the name of a text file, Correct-It will pass through the file and display words it does not recognize. The user has the option of leaving the word as is or correcting it in the text. Correct-It can add to its dictionary, so that it can "learn" new words as they occur in the text. It has a basic dictionary of 36,000 words and knows about the dot (text formatting) commands used by Wordstar.

Correct-It is well written, but slow. It took approximately a minute to load and sort a text file that consisted of a single sentence of 14 words, three of which were misspelled. For full-sized documents, it would be usable, but frustrating.

MBASIC and BaZic: The Micro Decision is available with two versions of BASIC. Microsoft BASIC is a stan-

(3b)

```
DISPLAY A DISKETTE DIRECTORY (DIR)

You may obtain an on-screen list of files on a diskette by
entering your choice after the OPTION prompt.

1  Display of files on current drive
2  Display of files on another drive or diskette
ESC  Exit to CP/MENU

OPTION :
```

(3c)

```
COPY A FILE

Choices in this menu allow you to copy a single file, or a group
of files, onto another diskette. The diskette upon which the
files will be copied must already be formatted and have enough
room to accept the new files. Enter your choice from the list
below after the OPTION prompt.

1  Copy a single file to another diskette
2  Copy all files on one diskette to another diskette
ESC  Exit to CP/MENU

OPTION :_
```

Photo 3: Menu-driven CP/M. Photo 3a shows the main menu and the CP/M commands that may be accessed through it. Photos 3b and 3c show the submenus for displaying the directory of a disk and copying a file.

IS THIS LEVEL OF RELIABILITY REALLY NECESSARY?

ACCUTRACK



If you've ever lost data due to a faulty disk, you know how important reliability can be.

That's why Accutrack disks are critically certified at 2-3 times the error threshold of your system. Why they're precision fabricated for higher signal quality, longer life and less head wear. And why we take such extra steps as testing single-density mini disks at double-density levels. So you don't have to worry about the reliability of your media.

Accutrack disks. OEMs have specified them for years. You can trust them for your data. Call toll-free (800) 225-8715 for your nearest dealer.



ACCUTRACK
Dennison KYBE Corporation

82 Calvary Street, Waltham, Mass. 02254
Tel. (617) 899-0012; Telex 94-0179
Outside Mass. call toll free (800) 225-8715
Offices & representatives worldwide

Dealers: Give your customers a choice—Accutrack's OEM performance as well as your heavily advertised brand. We have the industry's only complete line of disks, cassettes and mag cards, including virtually all special formats. If you want a quality line, small minimums, the ability to mix and match, private labeling, fast delivery and great price, call today. Find out how responsive a media supplier can be.

Circle 146 on Inquiry card.

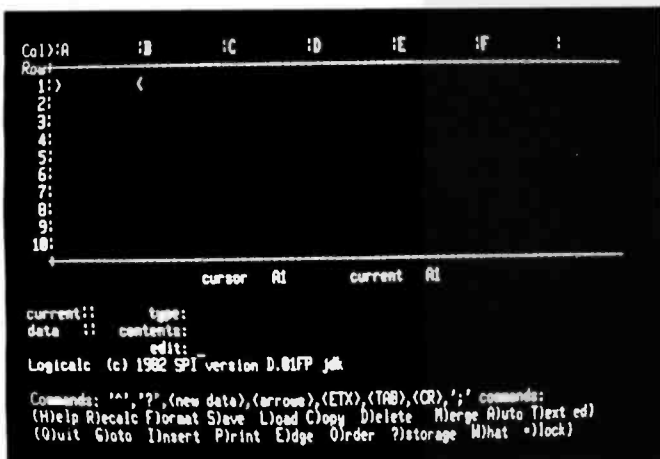

Photo 4: The Logicalc spreadsheet program.

standard in the personal computer industry, running on both 8080 and Z80 microcomputer systems. BaZic is a North Star-compatible BASIC interpreter (written by Micro Mike's Inc. of Amarillo, Texas) that uses the full Z80 instruction set. It is faster than MBASIC but more idiosyncratic. Many, but not all, MBASIC programs will run under BaZic.

Personal Pearl will be the database manager distributed as standard software with the Micro Decision. At the time of this review, Personal Pearl was unavailable for examination.

The Bottom Line

As previously stated, the price of midrange computers is approximately \$2000, and the price of various versions of the Micro Decision is roughly the same. However, the Micro Decision price can be reduced. It can be purchased without a terminal (\$595), bringing the price of the basic unit (MD-1) to \$1195. The MD-2 costs \$1545, and the MD-3 costs \$1695. Full systems cost \$1790, \$2140, and \$2290, respectively.

Comments and Conclusions

The Micro Decision would make a good second computer for people who are familiar with CP/M systems or for those who have had experience with computers. From a hardware-design standpoint, the system is well constructed and reliable. Morrow's software is not suitable for novice users; the documentation for Logicalc and Correct-It consists of references containing little in the way of tutorials (tutorials and examples are vital for inexperienced users).

The major failing of the system is its terminal; however, it is possible to purchase a Micro Decision without one. The software can be configured to work with most popular terminals on the market today. ■

Tom Wadlow is an engineer and freelance writer living in the San Francisco Bay area. He can be reached at Apt. 226, 5157 Norma Way, Livermore, CA 94550.

Low-cost Interface DiskSystems[®] for IBM PC-2.0 DOS



- 10, 15, 25 megabyte models available now!
- DiskSystem includes Winchester disk drive, cabinet, power supply, cable, controller, I/O adapter and device driver ■ Fully compatible with 2.0 DOS (unmodified) ■ Exclusive double shock isolation system ■ Standard warranty includes 90 days parts and labor

10 megabytes formatted storage \$1695
 15 megabytes formatted storage \$2295
 25 megabytes formatted storage \$2995

- 5 1/4" Winchester Backup or Additional Storage For IBM PC XT or IBM PC DiskSystem
 - Slave compatible with 2.0 DOS
- 10 megabyte formatted storage \$1425
 15 megabyte formatted storage \$1645
 25 megabyte formatted storage \$2295

Dealer Inquiries Invited

I² INTERFACE INC

7630 Alabama Avenue
 Canoga Park, CA 91304
 (213) 341-7914 Telex: 662949

MULTIUSER SYSTEMS MADE POWERFUL...



MultiMicro Computer raises expectations for multiuser systems.

In fact, our new system is so good we call it the MicroMainframe.®

And we can prove it.

Each user gets their own processor. Each processor has 64 K of RAM. The MicroMainframe has over 1 megabyte of system memory and up to 450 megabytes of hard disk memory.

That's right, 450 megabytes.

There's more.

An 8" double sided, double density floppy drive, RS-232, RS-422 or Centronics™ parallel interfaces, 20 slot chassis, real time clock, true record locking and quiet operation are standard. Streaming tape backup and 6 MHz operation are available.

It's also simple.

Up to 16 users can be accommodated easily. The power supply and cooling system have been designed for straight-forward, plug-in expansion.

... AND FAST...

Best of all, TurboDOS™ takes full advantage of the

MicroMainframe's direct memory access, memory management, and slave level memory architecture. That makes our system fast.

Very fast.

It can also run any CP/M™ program.

The best MicroMainframe around?

The only MicroMainframe around.

... AND INEXPENSIVE.

Our Base, 4 user system with 320 K of system memory, 16 megabytes of hard disk storage and a 1.2 megabyte floppy disk drive retails for only \$9950.00.

That's a fully expandable, 20 slot system. Additional users can be added for under \$750.00.

CALL.

Call today. We'd like to help you solve your multiuser problems.



Dealer inquiries invited.

MultiMicro Computer,
9631 Netherway, Huntington
Beach, CA 92646, 714/963-8954

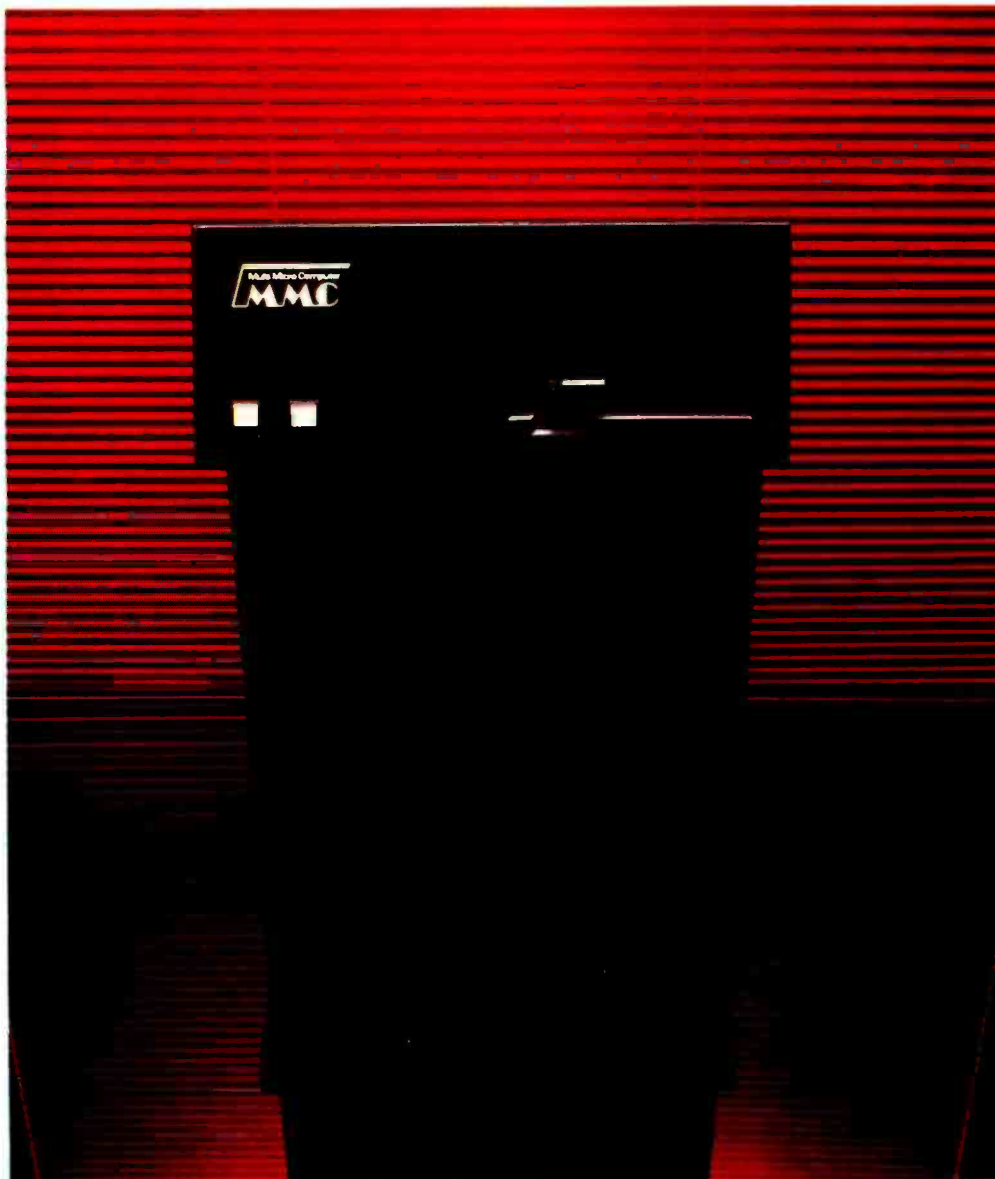
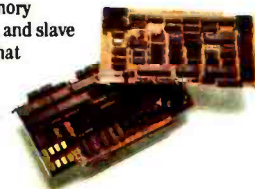

CP/M™ Digital Research. • TurboDOS™ Software 2000 Inc. • Centronics™ Centronics, Inc.

WRITE IT. PROOF IT. SEND IT.

THE WORD JUGGLER™ SYSTEM FROM QUARK.

If you're serious about word processing on your Apple IIe or Apple III, you should test the Word Juggler System from Quark. Integrated tools that combine ease of use with extraordinary power.

WRITE IT WITH WORD JUGGLER.

The anchor of the system is Quark's Word Juggler word processor, a program that lets you easily perform the most intricate editing tasks. For example, you can delete characters, words, even paragraphs with just a single key-stroke. You can instantly copy, move or delete entire blocks of text. Then display or print your document by simply pressing a key.

And there's virtually nothing to memorize. Because editing and formatting commands are always right there on the keyboard. Word Juggler for the Apple III comes with special templates which identify principal word processing functions. On our version for the IIe, the editing commands are labeled on easy-to-install, replacement keycaps.

Plus, Word Juggler lets you generate form letters from existing mailing lists, because the program has a built-in interface with both PFS:File and Apple's Quick File.

PROOF IT WITH LEXICHECK™

Once you've written your document, you can quickly proof it with Lexicheck—a high performance spelling checker with a 50,000-word dictionary. Simple and fast, Lexicheck is invoked from within Word Juggler by a single keystroke. The program scans your document and highlights unrecognized words in context. If the words are actually misspelled, you can quickly correct them. If words are merely unknown, as with jargon or abbreviations, you can add them easily to your own personal dictionary.

SEND IT WITH TERMINUS™

And with Quark's new Terminus communications program, you can use Word Juggler for electronic mail applications. A single keystroke invokes the program from within the word processor, allowing you to communicate with most any RS232 device. You can predefine the protocols you need to communicate with as many as 14 different systems, at transmission rates up to 9600 baud.

TEST IT TODAY.

Your dealer wants to give you a complete demonstration of all the features and capabilities of The Word Juggler System from Quark. And while you're there, check into Quark's full line of Office Automation Tools for the Apple III.

Word Juggler for the Apple III, \$295
Word Juggler IIe, \$239
Lexicheck for the Apple III, \$149
Lexicheck IIe, \$129

Terminus for the Apple III, \$89
Terminus IIe, \$89
All prices suggested U.S. retail

Quark™

INCORPORATED

Office Automation Tools

Circle 388 on Inquiry card.

Quark, Word Juggler, Lexicheck and Terminus are trademarks of Quark, Incorporated.

Apple and Quick File are registered trademarks of Apple Computer, Inc. PFS is a registered trademark of Software Publishing Corporation.

The Microneye

This low-cost image-sensing camera interfaces easily with a variety of popular microcomputers

by Dr. Chris Wieland

If you stop and think for a minute about science-fiction movies in which a computer goes wild and turns on its owner, the computer always possesses one attribute—vision. Invariably, as its hapless victim tries one thing after another to escape, the mad computer watches, blocking each attempt at just the last minute, the better to torment its victim. One can only assume that computers have a twisted sense of humor; surely, many computer users can attest to that fact.

Fortunately, such computers have thus far been kept in check because the cost of adding vision has been out of reach for nearly all computer users. So far, few stories

have appeared in the newspapers about home computers turning on their owners. This situation may change dramatically, however, thanks to the introduction of a product called the Microneye.

The Microneye is a low-cost (as little as \$295) imaging system designed to interface easily with a variety of popular microcomputers. Made by Micron Technology of Boise, Idaho, this solid-state camera is capable of recording high-resolution images at rates of up to 15 frames per second (or a frame every 67 milliseconds). In other words, this imaging device can function as a movie camera, catching the activity of any moving object. Con-

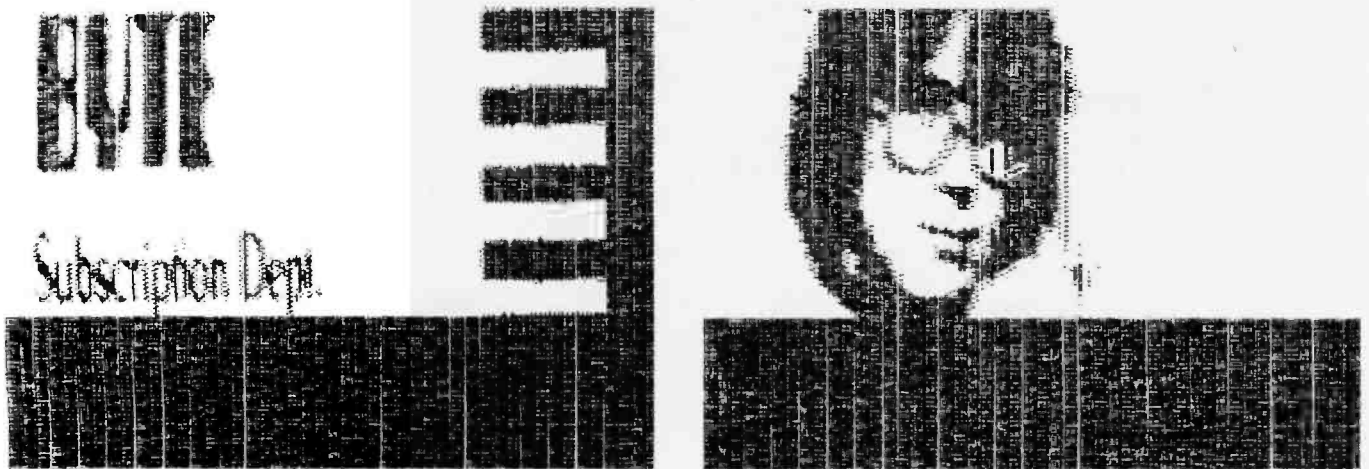
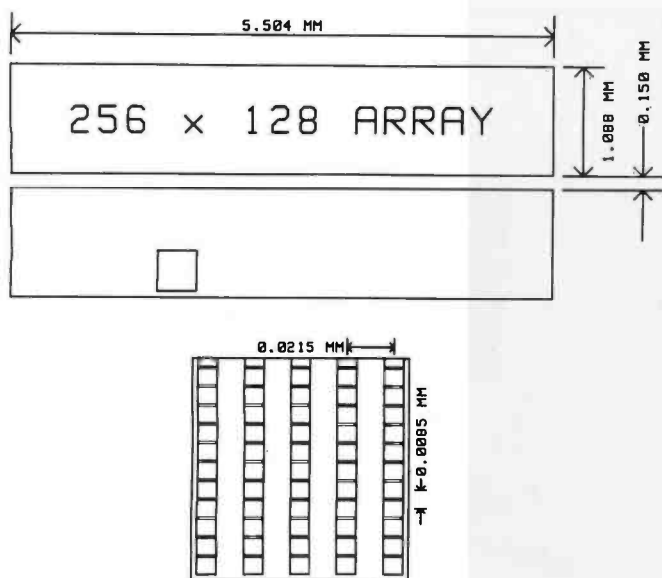

Figure 1: Two examples of images produced by the Microneye solid-state camera. On the left is a view of one of those annoying subscriber cards that fall out of magazines. On the right is a picture of a photograph of the author. The card was photographed at a distance of about 3 feet, the author's photo from about 5 feet. Both images were displayed on an Apple high-resolution screen and printed on an Axiom printer using a screen-dump routine. The broad black band at the bottom of each image is a result of the fact that the 256- by 192-pixel area of the Microneye does not completely fill the 256- by 192-pixel area of the Apple's high-resolution screen.



ENLARGEMENT OF DETAIL

Figure 2: Dimensions of the photosensitive array of the IS32 Optic RAM chip. Enlargement shows center-to-center spacing distances of individual light-sensing elements (pixels). Each pixel is 8 by 9 micrometers. Array and detail dimensions are drawn to scale.

sequently, the Microneye can be used for motion detection or image analysis; the camera can replace similar, but more expensive, solid-state systems such as those based on CCDs (charge-coupled devices) or photodiode arrays.

Inside the Camera

The basis of the Microneye camera, and a major reason for its low cost, is an integrated circuit called the IS32 Optic RAM, manufactured by Micron Technology. The RAM in the name of this image-sensing chip is well chosen because the chip is precisely that, a dynamic 64K-by 1-bit RAM (random-access read/write memory) circuit modified for image-sensing capabilities. This chip keeps the cost of the Microneye quite reasonable because the process of manufacturing dynamic RAM chips is already well established; thus, Micron avoided the cost of developing a totally new silicon technology.

Forming an Image

If you are familiar with the operation of dynamic memory, you know that dynamic RAMs must be refreshed (recharged) every so often or they lose their data. Each storage location, or bit, in the memory acts like a tiny capacitor or battery that slowly loses its charge if it is not periodically refreshed to its original voltage level.

When light falls on the surface of a dynamic RAM silicon chip, it accelerates the rate at which charge is lost from the memory locations in the chip. This photosensitive property is the basis of the image-sensing capability of the IS32 Optic RAM. The Microneye produces a picture for the host computer when an image is optically focused on the surface of the Optic RAM. Light from

At a Glance

Name

Microneye Bullet, Microneye camera, and RS-232 camera package

Manufacturer

Micron Technology Inc.
2805 East Columbia Rd.
Boise, ID 83706
(208) 383-4000

Price

Microneye Bullet camera, \$295; Microneye camera, \$485; RS-232 Microneye camera package, \$540

Hardware Required

Apple II Plus, IBM PC, or Commodore 64 with one disk drive; Radio Shack Color Computer or Commodore 64 with cassette interface; or any computer with RS-232C interface for RS-232 unit

Documentation

19-page operator's manual; program listings on copyable disk

Audience

Anyone who needs low-cost, high-resolution imaging

an image reaches the surface through a rectangular quartz window in the top of the IC. The window covers the small square of silicon comprising the chip and makes it look physically much like an EPROM (erasable programmable read-only memory) chip. To create the image, the data in every memory location is initially set to a value of logic 1. Then, after a specific delay, the data from the memory is read back. Under normal circumstances the data does not change; it is still all 1s. However, because light focuses on certain areas of the chip, indeed on specific memory storage "cells," the discharge rate of these memory locations accelerates. As a result, the contents of these particular memory locations change from 1s into 0s.

Now, if you take each memory location and display it on your computer's graphics display in the same configuration found on the surface of the Optic RAM (using a white dot to represent a 1 and a black dot to represent a 0), you'll have a picture of the image focused on the chip (figure 1).

The resolution of the IS32 Optic RAM chip is 128 by 256 pixels (picture elements). However, the Optic RAM actually contains two 128 by 256 photosensitive arrays separated by a narrow nonphotosensitive strip (see figure 2), making a total array size of 256 by 256 elements. Through software manipulation, you can partition the array into smaller units to provide, for example, zoom effects or to meet user requirements dictated by limited memory space. Thus, depending on your needs, you can form the picture into a square of 100 by 100 pixels or a long rectangle of 256 by 8 pixels.

You can choose from three models—the Microneye Bullet, the Microneye camera, and the RS-232 Microneye

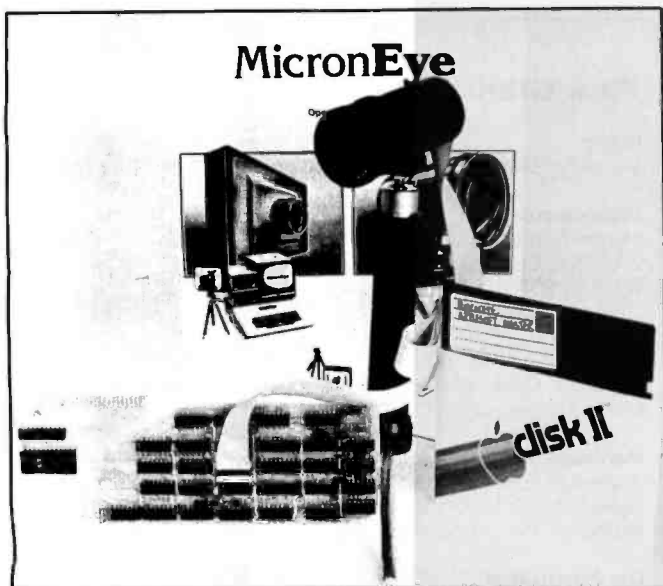

Photo 1: Microneye, Bullet version.

camera—to meet your computer, budget, and image-sensing requirements. The Microneye Bullet (photo 1) is designed for use with the Apple II Plus, the IBM Personal Computer, the Radio Shack Color Computer, and the Commodore 64. The name Bullet refers to the shape of the cylindrical case in which the image-sensing element is housed. This unit is quite small—less than 3½ inches long and 1½ inches in diameter—and is composed of only a C-mount lens and the IS32 Optic RAM chip in a cylindrical housing. A double-sided PC board that plugs into a specific user slot on each computer contains the electronics that interface the chip to the computer. Because the controls of the IS32 Optic RAM are located within the computer and because many signals must travel between the interface board and the Bullet unit, a user is limited to 4 feet of cable connecting the computer to the Bullet.

I am currently using this version with my Apple II Plus computer and find the short cable to be only slightly restrictive. A nice feature of this unit is its small size; it can be mounted where other image-recording devices would never fit.

A second version, the Microneye camera, has all the interfacing electronics, along with the Optic RAM and the lens, located in the camera case (photo 2). With this version, a six-conductor modular telephone cable connects the camera to a small 3- by 3-inch card located in the computer, allowing remote sensing at distances of up to 25 feet (although only a 6-foot cable is supplied with the unit). This second version is available for the same four computers listed for the Bullet.

The third version, the RS-232 Microneye camera, is fully self-contained and enables data and camera commands to be sent over a standard RS-232C interface, making it usable with nearly any computer. Externally, the RS-232 version looks identical to the Microneye camera.

Included with each camera is an easy-to-use software-driver package. This package comes on a 5¼-inch disk



Photo 2: Microneye, camera version.

for the Apple II Plus, IBM PC, and Commodore 64 or on cassette tape for the Radio Shack Color Computer and Commodore 64. Pascal and 6502 assembly-language listings are available for the RS-232 version. A small tripod is also included for camera mounting. All versions derive power from the host computer and use only 50 milliamperes of current from the +5-volt supply, owing to the extensive use of CMOS (complementary metal-oxide semiconductor) circuitry.

The User Interface

The software driver is quite easy to use; it is clear that Micron Technology worked hard to develop a software package that lets you quickly start up the camera with a minimum of difficulty and allows you to retain complete flexibility in changing the camera's operating mode. The main program begins by presenting a menu of operating conditions you select through single keystrokes. You can control the light sensitivity of the camera by selecting options from the menu; exposure times may be set at ranges from 0.001 seconds for bright images to 60 seconds for dimly lit scenes or time-exposure effects. In addition, the exposure rate can be set to a mode in which the time is automatically changed to match a user-selected light level. Pictures may be saved or loaded from the storage medium or dumped to a printer with graphics capabilities. When you use a graphics printer for display, you can generate images using gray levels (figure 3). This image generation is accomplished by averaging multiple samples of the same image (taken at varying exposures) to estimate the relative intensity of each pixel.

The software can be listed and copied and is fully documented with comments that even encourage a user to make modifications.

Possible Applications

If the preceding description has not yet made you rush to order the Microneye, perhaps a few ideas about ap-

Now 60 MHz or 100 MHz Tek quality is just a free phone call away!



Tek has expanded its best-selling 2200 scope line up to 100 MHz. And brought it all as close as your phone. Tek's revolutionary, reduced-component architecture brings unprecedented quality, reliability and affordability to the 60 MHz 2213 and 2215, and now, the 100 MHz 2235.

All three of these lightweight (13.5 lb.) scopes feature 2 mV/div vertical sensitivity and 5 ns/div sweep speeds, plus a complete trigger system for stable triggering on digital, analog or video waveforms.

Scopes with a comprehensive 3-year warranty*... probes... and expert advice. One free call gets it all! You can order, or obtain literature, through the Tek National

	2213	2215	2235
Bandwidth	60 MHz	60 MHz	100 MHz
No. of Channels	2	2	2 + Trigger View
Alternate Sweep	—	Yes	Yes
Vert/Trig B/W Limit	—	—	Yes — 20 MHz
Single Sweep	—	—	Yes
Accuracy: Vert/Horz	3%	3%	2%
Delay Jitter	1:5,000	1:10,000	1:20,000
Trigger'g Sensitivity	0.4 div at 2 MHz	0.4 div at 2 MHz	0.3 div at 10 MHz
Input R-C	1M Ω — 30pf	1M Ω — 30pf	1M Ω — 20pf
Variable Holdoff	4:1	4:1	10:1
Price	\$1200†	\$1450†	\$1950†

Marketing Center. Technical personnel, expert in scope applications, will answer your questions and expedite delivery. Direct orders include operating and service manuals, two 10X probes, 15-day return policy, and worldwide service back-up.

**Call toll-free:
1-800-426-2200,
Extension 84.**

In Oregon, call collect:
(503) 627-9000, Ext. 84.

†Price F.O.B. Beaverton, OR.
*3-year warranty includes CRT and applies to 2000 family oscilloscopes purchased after 1/1/83.
Scopes are UL Listed, CSA and VDE approved.

Tektronix®
COMMITTED TO EXCELLENCE

plications will change your mind. My own application for the Microneye involves automation of scientific animal-behavior experiments. Many studies of animal behavior require that the position, orientation, or mechanical motion of animals be recorded. Often, such material must be recorded for long periods of time at evenly spaced intervals; at other times, the activity to be recorded may last only 5 seconds and need to be analyzed 10 times per second. Such studies can be carried out with videotape or film systems; however, the extraction of data from these media is tedious, to say the least, and the cost of either system is prohibitive.

Because of the limitations of video and film, the introduction of the Microneye is welcome. Now, for a very low cost, the experiments mentioned above can be carried out automatically by a camera and computer; data collection as well as analysis can be automated (figure 4).

Some other applications for this solid-state camera include robotics, motion detection, security systems, image analysis and pattern recognition, graphic arts work, remote sensing stations, position and size monitoring for production, and inexpensive reading machines for the blind.

The Microneye camera is an extremely versatile image-sensing device that can be used in many personal, scientific, or industrial applications. The unit's cost, relatively low compared to standard video systems or more exotic schemes of image recording, makes it particularly attractive. ■

Editor's Note: For information on how you can build a digital camera similar to the Microneye, see page 67.



Figure 3: An example of an image incorporating gray levels, generated with a graphics printer.

Dr. Chris Wieland (Campus Box B-334, University of Colorado, Boulder, CO 80309) holds a PhD in biology. A research associate at the University of Colorado, he is studying the neurophysiology of animal behavior.

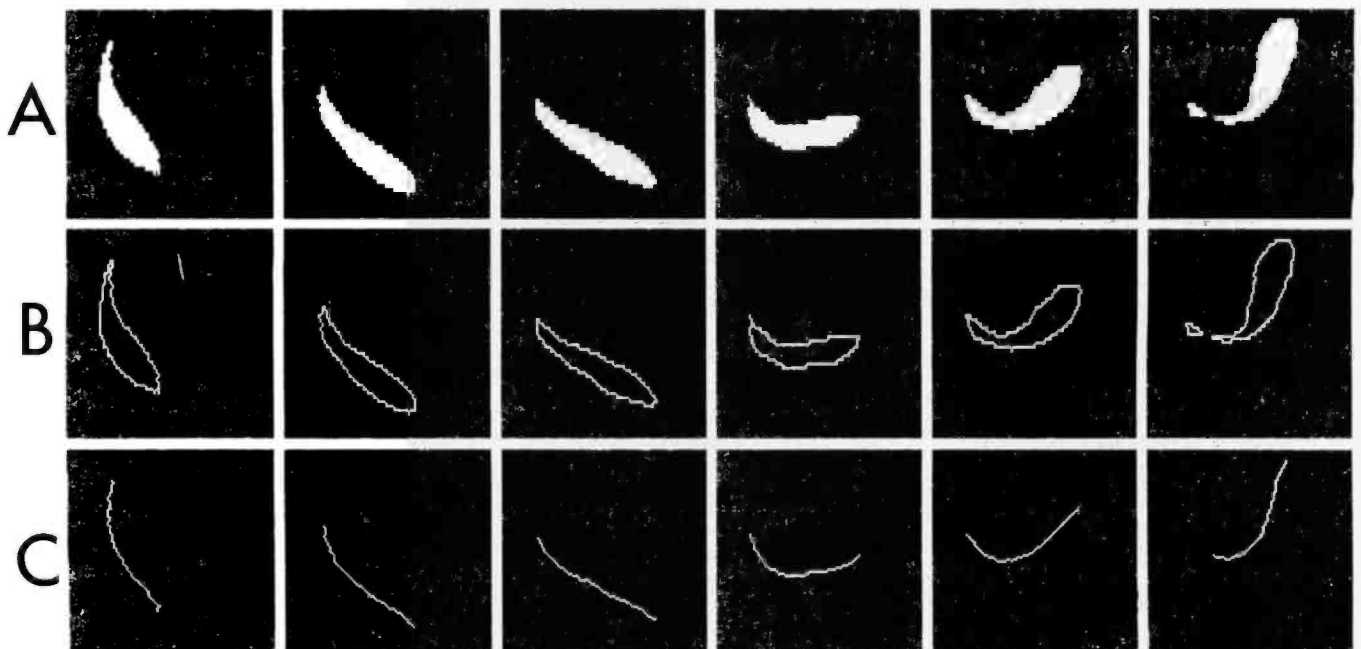

Figure 4: An example of image analysis based on a digital image generated by the Microneye. Shown are sequential frames, "filmed" from beneath a glass aquarium, of a goldfish executing a turn. Using binary image information supplied by the Microneye camera and image-analysis programs (designed by the author and not supplied with the camera), it is possible to determine mechanical properties (such as angular velocity and displacement speed) of the fish's turn. Time between each frame is 370 milliseconds. A shows the fish silhouette (the original camera image); B, the computer-generated outline; and C, the computer-generated midline.

Get together by satellite.



The world's largest privately owned earth station network lets you hold videoconference meetings at hundreds of Holiday Inn® hotels at the same time. For hotel reservations just call 800-HOLIDAY

*A better
place to beSM*



VoiceDrive...



© SuperSoft, Inc., 1983

USING A COMPUTER HAS NEVER BEEN THIS EASY.

The Future of Microcomputing

First there were punch cards
and paper tape,
then the terminal,
light pen,
and mouse.

Now there is **VOICE DRIVE** –
providing voice control of
computers – the next step in
making computers easier
to use. And at **SuperSoft**,
the future has arrived.

Imagine the freedom of using an electronic spreadsheet without having to touch the keyboard. You just say “insert column,” or “show me profits”... What could be simpler? Voice control is easier to learn, easier to remember, and easier to use than the keyboard. This means a faster learning curve and greater productivity.

Vocal engineering for specific applications.

VoiceDrive is software which interfaces to voice recognition hardware. It has taken the critical step of tailoring voice recognition to specific application programs. ScratchPad – SuperSoft’s state-of-the-art electronic spreadsheet – is the first program to utilize the VoiceDrive interface. Word processing, graphics, and others are soon to come. All VoiceDrive programs give you complete use of voice entry while still allowing traditional keyboard control.

ScratchPad with VoiceDrive. The spreadsheet you can talk to.

ScratchPad with VoiceDrive is the electronic spreadsheet which allows complete voice control of all commands and data entry. This is the key to providing solutions – solutions for secretaries and managers who don’t have time to learn cryptic keyboard commands – solutions for those who want to use a computer while doing other things like writing or looking through papers – solutions for those giving computer presentations who don’t want to be tied to a keyboard – and solutions for people who just wish computers were easier to use.

ScratchPad with VoiceDrive is currently compatible with the Tecmar voice recognition card for the IBM PC, with compatibility in other environments soon to come. Both software and hardware can be purchased through SuperSoft and its dealers worldwide.

ScratchPad with VoiceDrive: \$495.00
ScratchPad with VoiceDrive
and Tecmar Voice Recognition
Board: \$995.00

Japanese Distributor: ASR Corporation
International, 3-23-8, Nishi-Shimbashi,
Minato-Ku, Tokyo 105, Japan.

TEL. (03)-4375371. Telex: 0242-2723.

European Agent: SuperSoft International
Ltd., 51 The Pantiles, Tunbridge Wells, Kent,
England, TN2 5TE. TEL. 0892-45433.
Telex: 95441 Micro-G.

For more information about VoiceDrive
call or write: SuperSoft, P.O. Box 1628,
Champaign, IL 61820, 217-359-2112.
Telex 270365.

Circle 449 on inquiry card.

IBM PC is a trademark of International Business Machines.
Tecmar is a trademark of Tecmar, Inc., Cleveland, Ohio.

SuperSoft®

The M68000 Educational Computer Board

A look at Motorola's \$495, 68000-based single-board computer

by Robert W. Floyd

If you're interested in getting acquainted with Motorola's 68000 16-bit microprocessor but can't part with \$5000 or more, Motorola offers a usable system for only \$495. For that price, don't expect a disk drive and a Unix operating system, but do expect a 68000-based single-board computer with 32K bytes of RAM (random-access read/write memory) and what may be the best monitor program in ROM (read-only memory) ever developed.

At \$495 per unit, Motorola is not going to get rich by selling its Educational Computer Board (ECB). Obviously the strategy is to educate the coming generation of engineers and programmers about the 68000, with the expectation that they will design products that use the 68000. In addition to its intended audience of educators and students, this board is of interest to both hobbyists and people involved in developing 68000-based products. It is *not* a development system, but its interpretative assembler and disassembler make it handy to quickly test short routines.

The 68000

The 68000 is becoming an increasingly important microprocessor in today's market, as evidenced by the frequent announcements of products using the 68000. The chip is expandable by design, and Motorola has announced that a full 32-bit version will be available in 1984. Before jumping on the bandwagon, however, you should

know that the 68000 is not just a bigger version of the old 8-bit microcomputer; it is considerably more complex than many of the 16-bit minicomputers popular since the 1970s.

Before reviewing the system, I'll briefly highlight some of the major differences between the 68000 and the old 8-bit devices we're familiar with. The machine language supports byte, word (16-bit), and long-word (32-bit) operations. It has eight data registers and eight address registers, each 32 bits wide. Except for one register, A7, which is always the current stack pointer, all address and data registers are treated identically.

The processor operates in two states: user and supervisor. Certain instructions are legal only in the supervisor states. Once in the user state, the processor will stay there until an *exception* occurs. Exceptions may be caused by resets, interrupts, bus errors, a variety of runtime errors, and executions of TRAP. Besides some of the interrupt conditions, all exceptions are auto-vectorized; when the exception occurs, the processor gets the address of the exception-handling program from a specific location in memory. These exception vectors take up the first 1K bytes of memory and should all be initialized immediately after a reset occurs if you don't want your processor going off in strange directions.

The large number of 16-bit op codes makes a greater assortment of instructions possible. In the 68000, these possibilities appear as both new operations and a vari-

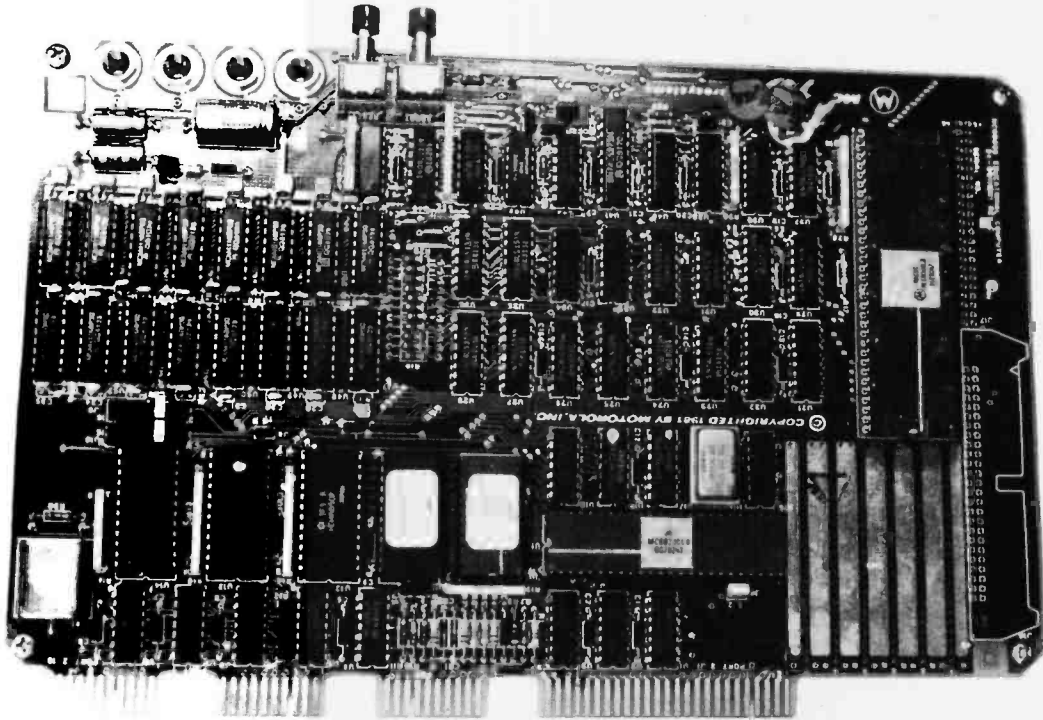

Photo 1: The very large integrated circuit (IC) in the upper right is the 68000. The other large IC near the wire-wrap area is the 48-pin MC68230 parallel interface/timer. The two serial interface ICs are at lower left. The edge connectors on the bottom are, from left to right, serial port 2 (host), serial port 1 (terminal), port 4 (cassette recorder), and port 3 (Centronics-type parallel printer).

ety of addressing modes for the standard operations. Most of these operations fall into the general scheme of supporting higher-level languages. These include instructions such as a branch subroutine (BSR), which allows relative branches to any address within 32K words above the program counter's address; the LINK and UNLINK instructions, which ease the construction of reentrant subroutines; and the move-multiple-registers instruction (MOVEM) for quickly saving registers. In addition, 12 addressing modes contain many instructions. These different modes are available for data transfer and logical and arithmetical operations. They can also be used in some of the transfer-of-control operations. In other words, a jump to subroutine (JSR) doesn't have to go to an absolute address—it might go to the address calculated by adding a data register to an address register plus an immediate value included in the instruction (by the way, that's one I haven't used yet). The result of this addressing arrangement is that it takes skill to write a program shorter than 64K bytes that is *not* relocatable, and it is very easy to write reentrant subroutines.

If Motorola simply added eight more address and eight more data lines to an 8-bit processor, only 56 pins would be needed. You well might ask what other functions have been added to require 64 pins. First, the 68000 is asynchronous in operation; it will not terminate any bus cycle until it recognizes that data transfer is complete, which is normally done by having the memory or pe-

ripheral device assert a data transfer acknowledge (DTACK). Because not all devices run asynchronously, the 68000 has a provision for synchronous devices, particularly those designed for the old 6800 microprocessor. In this case, a line called valid peripheral address (VPA) is used instead of DTACK.

When the 68000 detects this signal, it replies with a valid memory address (VMA) signal and synchronizes the bus operation to the Motorola 6800 E cycle. To provide more flexibility in the interrupt structure, three interrupt control lines produce seven levels of interrupts. Three bus arbitration lines allow DMA (direct memory access), refresh, and so on. One last note—RESET is bidirectional, so the 68000 can execute an instruction that resets all peripheral devices but does not affect operation of the processor.

Hardware

Let's take a look at what you get for \$495. The ECB is a single-board computer measuring 7½ by 10½ inches. The quality of construction is excellent. The board's edge contacts as well as its traces are gold plated. The ECB provides a 68000 operating at 4 MHz, a 16K-byte ROM monitor, 32K bytes of dynamic RAM, two RS-232C serial interface ports, and the MC68230 parallel interface/timer (PIT) that provides a cassette tape recorder interface, a Centronics-type printer interface, a 24-bit timer, plus

UP TO 40% OFF TANDON WAREHOUSE SALE!

CLEARANCE • CLEARANCE • CLEARANCE • CLEARANCE • CLEARANCE

TOLL FREE
1-800-321-3552

IN OHIO AND OTHER INQUIRIES (216) 481-4993

VERBATIM

5 1/4" (15/DEN) MD525-01	\$26.95*
5 1/4" (25/DEN) MD550-01	39.95
5 1/4" (25/4/DEN) MD557-01	51.50
8" (15/DEN) FD34-4000	43.95*
8" (25/DEN) FD34-4001	46.95*

WABASH BULK

5 1/4" (15/SD) W/HUB RING	\$3.59*
5 1/4" (15/4DD) W/HUB RING	1.89
5 1/4" (25/4DD) W/HUB RING	3.79
8" (15/SD) SOFT OR 32 SECTOR	1.69
8" (15/DD) SOFT OR 32 SECTOR	2.39
8" (25/DD) SOFT OR 32 SECTOR	3.09

BARE DRIVES

The Monitor's Special, OEM Version of Shugart
SA440 (25, 40/40) Slimline \$219.00

Manufacturer	Model	No. of Heads*	No. of Tracks	Full or Slimline	Price
Tandon*	5 1/4" TM100-1	1	40	Full	\$169.00
Tandon*	5 1/4" TM100-2	2	40/40	Full	249.00
Tandon*	5 1/4" TM100-4	2	80/80	Fuji	329.00
MPI*	5 1/4" Model 51	1	40	Full	179.00
MPI*	5 1/4" Model 52	2	40/40	Full	239.00
MPI*	5 1/4" Mdl 501	1	40	Slimline	179.00
MPI*	5 1/4" Mdl 502	2	40/40	Slimline	239.00
MPI*	5 1/4" Mdl 902	2	80/80	Slimline	329.00
MPI**	8" Mdl 41	1	77	Slimline	399.00
MPI**	8" Mdl 42	1	77/77	Slimline	499.00

For TRS-80, Heath, Zenith, IBM and Others

*The complete 5 1/4" Drives w/Case and Power Supply add \$54.95

**Call for details on 8" Case and Power Supply

APPLE AND FRANKLIN USERS

Franklin Ace 3000 Computer w/64K	\$799.00
Dumping-DX M. Resoluport	
Graphics Printer Interface w/Free Cable	129.00
Dumping-DX II Resoluport Graphics w/4K Buffer	269.00
IO Adapter plus Apple I/O w/Free Printer Cable	139.00
Fourth Dimension Apple Disk Drive w/1-Yr. Warr.	229.00
Fourth Dimension Disk Controller	89.00
Fourth Dimension Parallel Card and Free Cable	59.95

TRS-80 USERS

2-Disk II™ Disk Drive Upgrade*	\$219.00
Disk II™ Disk Drive Upgrade*	269.00
All Hardware and Cables for 2 Drives 1 Year Warranty 100% Compatible. NO soldering required.	
*Both with Free Disk Diagnostic Software.	
RG-232 Board for Both Model II and IV	\$ 79.95
LNW System Expansion I/O For Model I w/32K	349.00
MD Doubler 5 1/4" Double Density* Board for Model I	169.00
Sprint! Speed-Up Kit, 4 MHz Fast	89.95

SUPPLIES

5 1/4" File Box for 75 Diskettes	\$24.95
Avery Tabulabels 5000 3 1/2 x 5 1/8	15.95
Font Pad Paper 9 1/2 x 4 1/8 white 3000 count	29.95
7 1/4 x 1 1/8 white 3000 count	39.95
Head Cleaning Kit	17.95
16K Ram-Kit 1116 200 NS	17.95
64K Ram-Kit 4304 200 NS	79.00
Epson Printer Service Manual	29.95
Epson Gratex Plus Panel (Prices F.O.B. S.P.)	83.95

PRINTER BUFFERS

Quadrant Microfizer Parallel to Parallel w/8K	\$159.00*
Parallel to Serial w/8K	189.00
Serial to Serial w/8K	189.00
Serial to Parallel w/8K	189.00
All come with pause control and copy feature, and can be upgraded to 512K.	
Practical Peripherals MPB/EPSON w/16K	\$149.00
MPB/EPSON w/32K	189.00
Int-Line Parallel to Serial w/32K	289.00
Int-Line Parallel to Serial w/64K	339.00

MICRO DATA SUPPLIES

22295 EUCLID AVE. EUCLID, OHIO 44117

A SUBSIDIARY OF THE COMPUTER WAREHOUSE, INC. OF OHIO

WE ACCEPT
• Visa
• MasterCard
• Checks
• Money Order
• C.O.D.

ALL PRICES ARE FOR MAIL ORDER ONLY. Prices, Specifications and Offerings subject to change without notice.

ADD \$3.00 FOR SHIPPING & HANDLING \$5.00 Extra for C.O.D. Orders. Ohio Residents add 6.5% Sales Tax.

MOST SCHOOLS AND GOVERNMENT PURCHASE ORDERS ACCEPTED

Mnemonic	Function
HE	help, displays Tutor commands
MD	memory display
MM, M	modify memory
MS	store into memory
.A0-.A7	display/set address registers
.D0-.D7	display/set data registers
.PC	display/set program counter
.SR	display/set status register
.SS	display/set supervisor stack pointer
.US	display/set user stack pointer
DF	display formatted registers
OF	display offset registers
.R0-.R6	display/set offset registers
DC	convert decimal to hexadecimal
BF	block of memory fill
BM	block of memory move
BS	block of memory search
BT	block of memory test
BR	set a breakpoint
NOBR	remove breakpoint
GO, G	execute user program
GT	execute until breakpoint
GD	execute without setting breakpoints
TR, T	trace
TT	temporary breakpoint trace
DU	dump memory to a port
LO	load memory from a port
VE	verify memory load/dump
PA	printer attach
NOPA	reset printer attach
PF	port format
TM	transparent mode
*	send message

Table 1: The commands available in the Tutor monitor.

some uncommitted I/O (input/output) pins for a user to play with (see photo 1).

The MC68000L4 microprocessor in this kit is the slowest version Motorola makes of this chip, running at 4 MHz (compared to 12 1/2 MHz for the fastest version). Remember: this board was designed for educators, not benchmark freaks. Yet even at this leisurely pace its minimum instruction time is only 1 microsecond. Because any given instruction on a 16-bit chip generally does a lot more than a single instruction on an 8-bit microprocessor, the throughput of a slow 16-bit chip is several times greater than that of the fastest 8-bit machine.

Dysan Software Duplication:

It's your name on the package label. And your company's reputation on the line. Whether your program retails for \$40.00 or \$400.00, or is for company internal distribution, the cost of duplicating it on diskettes is just a fraction of the value of your product. Doesn't it make sense to protect the time, money and talent invested in your software with the finest and most complete software duplication services available?

Quality Software Deserves the Quality Media.

Dysan's software duplication services are unsurpassed for fidelity of reproduction. Not only is your program copied unerringly onto the finest media made—the Dysan diskette—but it's also copied on proprietary equipment manufactured by Dysan, exclusively for Dysan. Plus Dysan offers you the widest variety of support services available—from software protection to serialization and packaging.

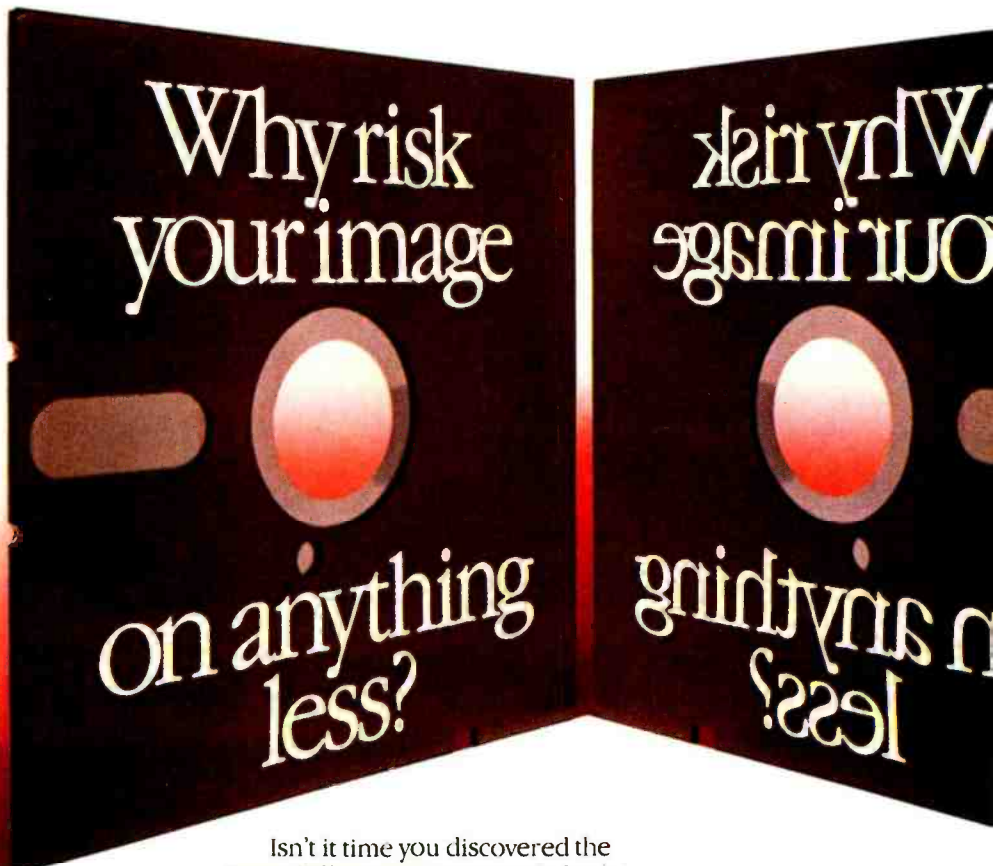

Isn't it time you discovered the Dysan difference? For more information on Dysan software duplication, fill out and return this coupon today, or call (800) 551-9000.



Circle 164 on inquiry card.



Dysan Software Duplication Division
5201 Patrick Henry Drive
Santa Clara, CA 95050
(800) 551-9000
(408) 988-3472

Please send me more details on
Dysan's Software Duplication Services.

B10

Name: _____

Company: _____

Address: _____

City: _____ State: _____ Zip: _____

Phone: () _____

PURE POWER CONTROL CENTER

Introducing a powerful new link for
your computer system:
The Power Directors
from Computer Accessories.

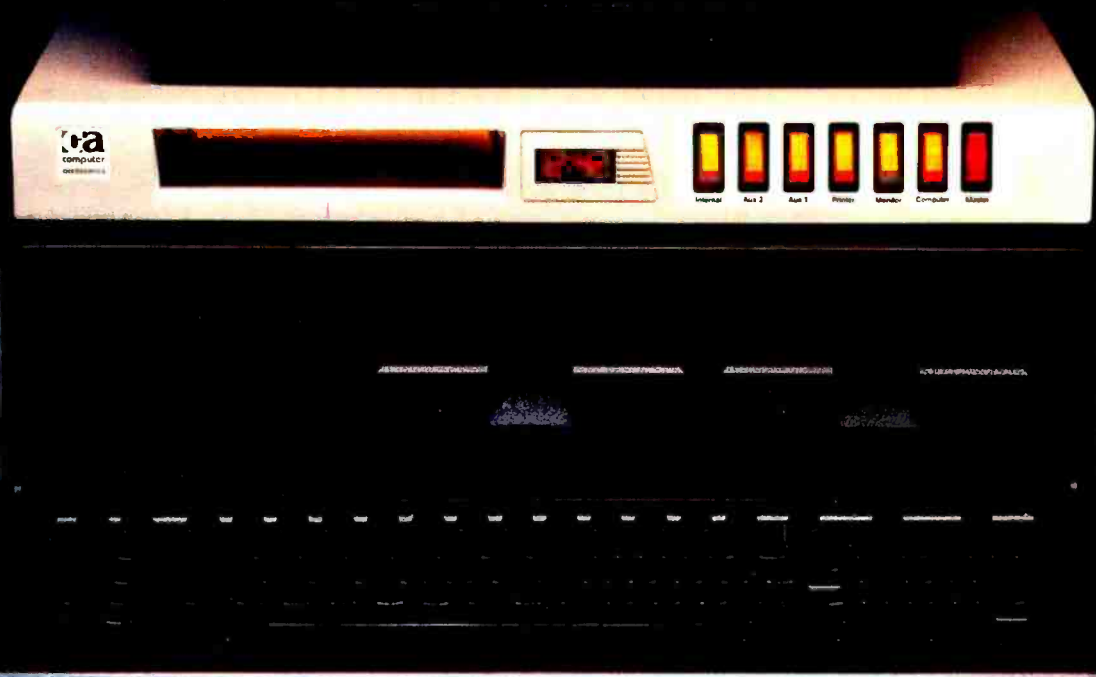

Power Directors incorporate UL approved TranZorb™ semiconductor technology and exceed the 1983 IEEE-587 Guide for surge voltages in low voltage AC power circuits. So you can protect your computer system from line surges and noise, giving it the pure power it needs. Voltage spikes are stopped in less than a nanosecond, EMI/RFI line noise is filtered out, and current overloads are prevented. Now your system can be truly integrated with

central power control like the Model P12 shown above. Instead of a haphazard maze of power lines and extension cords, each component plugs into the fully shielded Power Director. You can turn on each component individually, or power up the entire system with a single switch.

Look for the full line of Power Directors wherever personal computers are sold. TranZorb is a product of General Semiconductor Industries of Tempe, Arizona.



Computer Accessories Corporation, 7696 Formula Place, San Diego, CA 92121 (619) 695-3773

The 32K bytes of RAM are located in the lowest memory space and consist of sixteen 16K by 1-bit dynamic RAM chips. The monitor program, which resides in two 8K by 8-bit ROMs, is located in address space 8000 to BFFF (hexadecimal), making it awkward to expand the RAM because any additional memory will be noncontiguous with the original RAM. (Because it should be no more difficult to have the monitor reside at higher memory, why not do so and give hobbyists more flexibility?)

Communication to the ECB is through one of its two RS-232C serial ports. The data rate is user-selected from 110 to 9600 bits per second. Although any RS-232C terminal can be used, a video terminal is definitely preferable. For example, if you are doing a program trace, displaying eighteen 32-bit registers can burn a lot of paper and time. Also, the assembler works by first disassembling an instruction, letting the programmer change it, then overwriting the original instruction with the new. This makes for a pretty messy display if you're using a teletype.

In addition to the transmit and receive lines (pins 2 and 3), serial port 1 must supply the DTR (data-terminal ready) signal. Pin 1 is not connected on the board, so make sure ground is tied to pin 7 on your DB-25 connector. The other serial port, the designated host port, allows the ECB to act like a terminal to a host computer, which enables programs to be downloaded from (or uploaded to) a host computer. The serial ports on the ECB come out to 20-pin edge connectors instead of to a DB-25 connector. If you don't want to make or modify your own cables, Motorola sells cables that mate from the edge connector to a standard DB-25.

The operation of the MC68230 PIT, a remarkable device in itself, requires a 32-page manual. The chip provides three 8-bit parallel ports with handshake and a 24-bit timer. Separate interrupt vectors for both the parallel ports and the timer may be stored in the PIT. This chip supports a Centronics-type parallel printer port (which drives my Epson MX-80) and provides a cassette-recorder interface.

In addition to the peripherals, you need a power supply for the ECB. The board requires only 5 volts at 750 milliamperes and +12 volts at 100 milliamperes. All the components are tied together on the board on a simple, unbuffered bus. Although there is no edge-of-board connector for system expansion, most of the 68000's pins are brought out to a wire-wrap area, and a provision exists for inserting a 50-pin connector for expansion by the user. Because these lines are unbuffered, three-state buffers should be installed if more than a couple of extra chips are added to the bus.

Software

The ECB contains a monitor in ROM called Tutor. In addition to the usual monitor functions, it provides a disassembler and a line-by-line assembler. Compared to what else is on the market, the monitor alone is worth

Speed up system construction and provide better performance with Vector's

S-100 & STD BUS MAINFRAMES

- Supplied with high performance Faraday shielded motherboards.
- Integral card racks with plastic guides.
- EMI filtered. Fan. Heavy duty power supply.
- Quality aluminum case with interchangeable slide out vinyl finished panels in various colors.



STD BUS
(IEEE P961)
VP200
Mainframe
\$750.00

S-100 BUS
(IEEE 696)
VP100
Mainframe
\$725.00

NEW S-100 FUNCTIONAL BOARDS



RAM 17 — 64K of low power static RAM for CPU speeds to 10 MHz. 8800GR17B . . \$450.00.

○ INTERFACER 1 — Two RS232 ports, 50—19200 Baud, USART's perform all basic I/O functions. 8800G1B . . \$295.00.

○ INTERFACER 2 — Three parallel ports, one RS232 port, selectable rate interrupt timer. 8800G12B \$325.00.
* Trademarks of COMPUPRO.



12460 Gladstone Av., Sylmar, CA 91342-0336; (213) 365-9661

SEE US AT WESCON BOOTHS 1717 & 1719

103

Circle 495 on inquiry card.

October 1983 © BYTE Publications Inc. 329

← Circle 102 on inquiry card.

At a Glance

Name

M68000 Educational Computer Board (Motorola part # MEX68KECB)

Manufacturer

Motorola Inc.
Microsystems Division
3102 North 56th St.
Phoenix, AZ 85018
Distributed by Hamilton/Avnet Electronics

Hardware

Single-board computer, 6½ by 10½ inches, containing a 68000 microprocessor running at 4 MHz; 16K-byte monitor ROM; 32K-byte dynamic RAM; two serial I/O ports with data rate individually selectable from 110 to 9600 bps; MC68230 parallel port/timer that provides three 8-bit parallel ports with handshaking; audio cassette I/O; Centronics-type printer port; and wire-wrap area. Operation requires an external power supply (+5V at 750 mA, +12V at 100 mA), RS-232C-compatible video terminal, and connecting cable

Software

16K-byte monitor ROM with most of the functions of the Motorola Macsbug plus interpretative assembler, disassembler, printer and tape recorder functions, and a series of TRAP #14 functions that allows user program access to most of the monitor data conversion and I/O routines

Options

Interface cables to connect computer board to terminals, printers

Price

\$495

Warranty

90-day warranty includes parts, labor, and return shipping

Documentation

Over 450 pages, including data sheets on LSI circuits, a software manual for the 68000, and a manual on the ECB hardware and monitor

Audience

Educators, students, hard-core hobbyists, and 68000 systems developers who would like to use the ECB as a supplementary aid

bly-language programs starting at an even address, such as 1000 hexadecimal. If you are following the book *68000 Assembly Language Programming* by Gerry Kane, Doug Hawkins, and Lance Leventhal (Berkeley, CA: Osborne/McGraw-Hill, 1981), you will notice that all the programs in the book start at 4000 hexadecimal. However, if more than one program is being used, the others have to reside somewhere else in memory.

Assigning the starting addresses of the routines to offset registers makes testing the routines a lot easier. Let's try an example. Assume you have a routine that starts at 4F7E hexadecimal and you'd like to test a piece of code hexadecimal 1A6 bytes from the origin. If adept at this sort of thing, you could perform hexadecimal arithmetic, come up with 5124, then type GO 5124. An easier way of doing this is to set R1=4F7E and then type GO R1+1A6 (or whatever displacement you need). The same technique is used for looking at the *n*th item of a buffer and checking the value in a peripheral chip.

The block search command (BS) lets you search through any block of memory looking for either ASCII (American National Standard Code for Information Interchange) strings or binary data. This is useful when looking for particular memory references, such as I/O locations. The block fill command (BF) is useful for zeroing memory or buffers or for setting ASCII buffers to all space characters. The GO command starts program execution at a specified location, but a return from subroutine (RTS) will not return to the monitor. To do so, you have to use a special TRAP instruction.

In transparent mode (TM), the ECB acts as a dumb terminal to a host computer. Everything received on port 1 is immediately transmitted on port 2. I was able to use the TM command to good advantage when installing the ECB in my Heath H-19 video terminal. Internally, I wired the output of the H-19 to the terminal port of the ECB, and the ECB's host port to the input of the H-19. When first powered on, the H-19 talks to the ECB; but once TM is executed, it behaves like a normal H-19.

DU (dump) and LO (load) commands let you dump automatically formatted binary files either to or from memory. Normally this command is used with port 4 for a tape recorder or with port 2 to a host computer. The VE (verify) command reloads a program saved using the DU command and verifies that it matches what is in memory. The contents of memory can be either dumped or loaded using the DU and LO commands, respectively. Memory is dumped in what Motorola designates "S" records, which consist of header and data dumps in hexadecimal ASCII. You can use the DU command with all supported I/O channels (terminal, host, printer, and cassette tape). The LO command supports input from all but the printer. Because data is transferred in hexadecimal ASCII instead of straight binary, 2 bytes need to be saved for every single byte of actual data, which can be annoying when you have to wait two minutes to load a 4K-byte file.

Probably the two most important parts of the monitor are the assembler and disassembler. These features are

the price of the board. Table 1 lists the monitor commands provided in Tutor. Most of them resemble those of run-of-the-mill monitors, but a few require some explanation. Note the variety of addressing commands for Tutor. Most other monitor commands work only in the immediate mode (the user enters the explicit physical address), but Tutor has eight separate addressing modes. The most important of these are absolute, absolute plus the contents of an offset register, address register indirect, address register plus displacement indirect, and memory indirect.

One of the more sophisticated monitor commands is .Rn, which enables you to display and modify any of the eight special registers. Remember that the 68000 programs are intrinsically relocatable. These registers help users write position-independent code by being automatically added to addresses specified in Tutor commands. For example, it's generally easier to write assem-

Only 84 more Shopping days 'til Christmas!



ROCKY MTN. MICRO, INC.

HIGH TECHNOLOGY PRODUCTS & SERVICE FROM THE HIGH COUNTRY

IBM-PC HARDWARE

PLANTRONICS, Colorplus	\$ 369.00	HAYES 1200	\$ 469.00
QUADRAM CORPORATION		Internal modem on a card	
QUADBOARD Multifunction Board		TANDON TM	\$ 232.00
Full expandability from 64K to 256K		100-2 320K Drive	
Parallel Printer Port		TANDON "SLIM-LINE"	\$ 259.00
Asynchronous RS232C Serial Modem Port		TM50-2	\$ CALL
Programmable Clock Calendar		QUADLINK	\$ CALL
RAM Disk Drive (software)		AST	\$ 303.00
64K starts at	\$ 299.00	6 PACK PLUS 64K 364K, one ser, one par. cc	
MICROFAZER Printer Spooler			
Print Buffering from 8K to 512K			
Any Printer Computer Combination			
Why wait on your printer?			
Prices start at	\$ 129.00		
QUADCOLOR IBM Color Card	\$ CALL		
QUADCOLOR II 640 by 200	\$ 229.00		
STB SYSTEMS "SUPER RIO" CARD			
The Truly ultimate IBM add-on Eight+ Functions on one card.			
• 64-256K (786K w/opt "PiggyBack" card)			
• Two RS232C ports, one parallel			
• Parallel cable			
• Clock/calendar	• Game Port		
• Serial cable	• RAM disk		
• Printer Buffer			
Simply The Best	\$ CALL		

QUME'S SUPERIOR HALF-HEIGHT 320K DRIVE
 QumeTrak 142 features
 Ceramic R/W Head,
 Advanced Steel Band Head
 Positioner & 4 Drive Daisy
 Chain capability . . . \$ \$229.00

KEY TRONIC, INC.
 Enhanced Word Processing Keyboard
 Model KB-5150
 Familiar key placement for touch-typists. Key legends instead of obscure symbols \$ 205.00

IBM-PC SOFTWARE

TEMPLE OF APSHAH	\$ 29.00	PC TUTOR	\$ 43.95
MULTIPLAN	\$ 185.00	WOODSTAR	\$ 301.95
DBASE II	\$ 457.00	HOME ACCOUNT PLUS	\$ 91.50
EASY WRITER II	\$ 234.75	MULTIPLAN	\$ 185.50
PFS FILE	\$ 93.95	LOTUS 1,2,3,	\$ CALL
PFS REPORT	\$ 83.75	PFS GRAPH	\$ 93.95
VISICALC	\$ 182.95	DEADLINE	\$ 33.50
COPY II PC	\$ 29.00	FACEMAKER	\$ 24.95
FROGGER	\$ 23.50		

COLUMBIA DATA PRODUCTS

THE ENHANCED IBM ALTERNATIVE
TRULY IBM COMPATIBLE!!

IBM Hardware & Software compatibility in a Multi-User 16 Bit computer. 128K two serial ports, one parallel port and 8 expansion slots. Can run MP M 86, OASIS-16, MS-DOS "Super-Pak" includes MS DOS & CPM 86 operating systems, Macro-Assembler, Diagnostics, Basic w/ colorgraphics PLUS Perfect Writer, Speller Calc and File. Fast Graph, Space Commanders & Home Accountant \$ CALL

COLUMBIA PORTABLE-COLUMBIA VP, 128K Slim Line Drives, 9" monitor, (amber or green) comes w/MS-DOS super pak \$ CALL

APPLE/FRANKLIN HARDWARE

FRANKLIN ACES-THE APPLE II+ / IIE ALTERNATIVES

ACE 1000 (64K)		ACE 1200 (128K)	
Upper & Lower Case		Move over IIE	
Automatic Key Repeat	WITH COLOR!	Has everything the 1000 has plus	
Numeric Keypad		280 Card (CP M) + 80 columns	
Larger power supply with fan		Built-in drive, built-in color	\$ CALL
Call for Special package price			

MICRO-SCI A2 Disk Drive	\$ 229.00	MICROBUFFER II 16K	\$ 209.00
RAMA SYSTEMS - ELITE SERIES		VIDEX PSIO Dual Function Card	\$ 176.00
300% Faster than Disc II		Modem and Printer Ports	
Elite I (up to 163K)	\$ 289.00		
Elite II & III	\$ CALL		
Compatible Controller Card	\$ 55.00		

VISTA COMPUTER CO. INC.
 PRESENTS THE V1200:
 Removable mass storage for your Apple!
 6 meg (formatted) per 5 disc cartridge. Comes complete w/ drive, cable, controller, software and one 6 meg Vistapak cartridge.
 All for only \$1298.00

RAM EXPANSION		MISCELLANEOUS	
Davong (16K)	\$ 49.95	ALF PRODUCTS, INC. 8088 Processor:	
Microsoft (16K)	\$ 75.00	Powerful "IBM" chip on a card:	\$ CALL
Microtek (BAM 16K)	\$ 73.00	ANTI-STATIC TOUCH MATS	\$ 68.00
80 COLUMN CARDS		KENSINGTON, System Saver	\$ 72.00
ALS, Smartterm II	\$ 129.00	KRAFT, Joystick	\$ 48.00
Videx, UltraTerm	\$ CALL	Paddles	\$ 35.00
VideoTerm ComboPkg	\$ 271.00	M & R ENTERPRISES	
Vista, Vision 80	\$ 239.00	Sup'r Mod Universal	\$ 55.00
PRINTER INTERFACES/BUFFERS		Sup'r Fan	\$ 38.00
Microtek, RV611C par.	\$ 63.00	MICROSOFT	
Apple Dumping 16K	\$ 160.00	Softcard W/CPM 280	\$ 245.00
Orange Micro, Grappier+	\$ 119.00	Softcard Premium Pack	\$ 495.00
Buffered Grappier+	\$ 189.00	Softcard Plus (Franklin)	\$ 445.00
		T & G PRODUCTS	
		Joystick	\$ 43.00
		Game Paddles	\$ 28.50
		Select-a-port	\$ 43.00
		Trak-Ball	\$ 47.00
		SATURN SYSTEMS, INC.	
		Neptune 80 column card w/64K for IIE	\$ CALL

MILE-HIGH SAVER

APPLE COMPATIBLE DRIVES

FOURTH DIMENSION MICRO SCI
 \$219.00 \$229.00



PRINTERS - DOT MATRIX

C-ITOH		
Prowriter I - par	\$ CALL	
Prowriter II - par	\$ 649.00	
EPSON		
FX-80, FX100	\$ CALL	
GORILLA, Banana	\$ 209.00	
IDS, Prism	\$ CALL	
Microprism	\$ 559.00	
MANNESMANN TALLY		
MT1601	\$ CALL	
MT160L	\$ CALL	
OKIDATA		
82A	\$ 419.00	
83A	\$ 706.00	
84 par	\$1055.00	
92 par	\$ 499.00	
93 par	\$ 927.00	
STAR MICRONICS		
Gemini 10X	\$ CALL	
QUANTEX		
7030 (Dot Letter Quality)	\$1695.00	
BROTHER HR-1	\$ 884.00	
C-ITOH		
Starwriter F-10-40 par	\$1179.00	
JUKI 6100, 18 CPS	\$ CALL	
NEC		
3550 IBM plug-in	\$1936.00	
TTX-1014, Pin & friction feed, ser & par interface	\$ 516.00	

MONITORS

AMDEK,	300 Amber	\$ 155.00
	300 Green	\$ 139.00
	310A including cable	\$ 179.00
	Color I composite	\$ 299.00
	Color II RGB (IBM compatible)	\$ 439.00
GORILLA,	Green Hi-Res	\$ 89.00
NEC,	1201 Hi-Res, Green	\$ 159.00
	1203 RGB	\$ CALL
	1205 Hi-Res Amber	\$ CALL
TAXAN	Amber	\$ 129.00
	Green	\$ 119.00
USI	Amber Hi-Res	\$ 149.00
ZENITH	Green Med Res	\$ 99.00

DISKETTES & STORAGE

MEMOREX	10 each 5 1/4 SS DD	\$ CALL
	10 each 5 1/4 DS DD	\$ CALL
ELEPHANT	10 each 5 1/4 SS DD	\$ 19.95
	10 each 5 1/4 DS DD	\$ 26.95
VERBATIM	10 each 5 1/4 SS DD	\$ 25.95
	10 each 5 1/4 DS DD	\$ 36.95
ZIMAG	12 each 5 1/4 SS DD	\$ 19.95
LIBRARY CASE, 5 1/4		\$ 2.50
DISK BANK, 5 1/4 Interlock & swivel		\$ 5.50
DISK FILE, 5 1/4 Elephant "Trunk"		\$ 21.95

NEC APC

Color APC, 128K Bytes of User Memory, Dual 1 Megabyte FDD's, Communications Controller, Printer Controller, Auto Power off, Battery Back-up, 4K CMOS RAM & Hardware Clock/Calendar Programmable Character Set, Detached Keyboard w/Programmable Function Keys & Numeric Pad, Model HO3 \$ CALL

MODEMS

ANCHOR AUTOMATION	
Signalman Mark 1	\$ 83.00
HAYES	
Smartmodem 300	\$ 211.00
Smartmodem 1200	\$ CALL
Smartmodem 1200B	\$ 459.00
Micromodem II w/Terminal program	\$ 299.00
NOVATION	
CAT (Acoustic)	\$ 453.00
D-CAT	\$ 168.00
J-CAT	\$ 115.00
Auto Cat	\$ 219.00
Apple Cat II	\$ 273.00
212 Module (1200 baud opt. for Apple Cat II)	\$ 345.00
212 Appie Cat II (1200 baud)	\$ 626.00

VISIT OUR WAREHOUSE OUTLET STORE

Rocky Mountain Micro, Inc.

MAIL ORDERS: 10890 E. 47th Ave. Denver, Colorado 80239

- TERMS AND CONDITIONS:**
- NO CREDIT CARD FEE
 - Personal checks (allow 10 days to clear), Visa, Master Card, wire transfers, include telephone number
 - COD orders accepted - \$300 maximum - \$10 nonrefundable surcharge - All products factory sealed with manufacturer's warranty
 - PO's accepted from qualified customers - Approval needed on all returns - 10% restocking charge unless defective plus shipping
 - All Colorado residents add 3.5% sales tax. City & County of Denver residents additional 3.6% sales tax
 - Shipping, Handling & Insurance \$5.00 minimum, 4% UPS ground; UPS Blue Label rate quoted at time of order
 - All prices subject to change without notice
 - Export orders accepted from foreign dealers, Contact F. L. Kleinberg & Co. TWX 910-940-2517
 - Telephone Order Desk Hours: 8 AM to 6 PM, Monday through Friday, 10 AM to 4 PM Saturday, Mountain Standard Time

NATIONAL ORDER DESK: **1-800-862-7819**

IN COLORADO CALL: 303-371-2430

TECH ASSIST. & CUSTOMER SERVICE
 CALL 303-371-2430
YOUR SATISFACTION IS OUR BEST ADVERTISING!
WE SERVICE WHAT WE SELL

System Saver[®]

The most important peripheral for your Apple II and IIe.



For Line Surge Suppression

SYSTEM SAVER provides essential protection to hardware and data from dangerous power surges and spikes. Dangerous voltage spikes are clipped off at a safe 130 Volts RMS/175 Volts dc level. High frequency noise is smoothed out before reaching the Apple II.

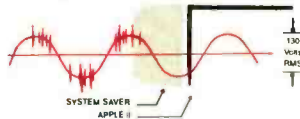

For Cooling

Today's advanced peripheral cards generate more heat. In addition, the cards block any natural air flow through the Apple II creating high temperature conditions that substantially reduce the life of the cards and computer itself. SYSTEM SAVER's fan exhausts 15 cubic feet of air per minute.

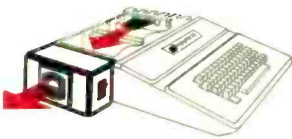

For Operating Efficiency

SYSTEM SAVER contains two switched power outlets. SYSTEM SAVER efficiently organizes your system so that one convenient, front mounted power switch controls SYSTEM SAVER, Apple II, monitor and printer. The heavy duty switch has a pilot light to alert when system is on. You'll never use the Apple power switch again. Also available in 220/240 Volt. 50/60 Hz.

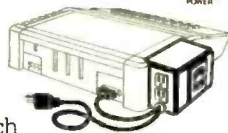
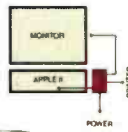

Easy Installation

Just clips on. Color matched to Apple II.

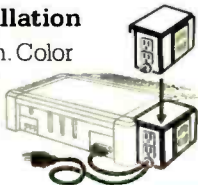

Fits on Apple Stand



\$89.95 at dealers everywhere or order direct by phone or mail. For phone or mail orders include \$2.50 for handling. New York State residents add sales tax. VISA and MASTERCARD accepted. Dealer inquiries invited.



919 Third Avenue • New York, NY 10022 • (212) 486-7707
Telex: 236200 KEN UR

004030	FFFF	DC.W	9FFF ?.
TUTOR 1.1 >	MD 4000 2F;DI		
004000	307C6000	MOVE.W	024576, A0
004004	4200	CLR.L	D0
004006	1010	MOVE.B	(A0)+, D0
004008	6724	BEQ.S	\$00402E
00400A	43E00001	LEA.L	1(A0), A1
00400E	00010000	BCLR	00, D1
004012	5340	SUBQ.W	01, D0
004014	600E	BRN.S	\$004024
004016	0300	CMPH.B	(A0)+, (A1)+
004018	630A	BLS.S	\$004024
00401A	1420	MOVE.B	-(A0), D2
00401C	10E1	MOVE.B	-(A1), (A0)+
00401E	12C2	MOVE.B	D2, (A1)+
004020	00C10000	DSET	00, D1
004024	51C0FFFO	DBF.L	D0, \$004016
004028	00010000	BTST	00, D1
00402C	6602	DNE.S	\$004000
TUTOR 1.1 >	MM 402E;DI		
00402E	4E73	RTE	? RTS_

Photo 2: The assembly and disassembly functions, invoked by typing DI after a memory display or memory modify command. Assembly is done line by line—the code at the current memory is first disassembled and followed by a question mark. The programmer then types in the correct code, and the original code is overwritten with the new. Any value not recognized as a valid op code is disassembled as the declare word (DC.W) pseudo op.

of much greater necessity than their counterparts on an 8-bit computer. Many times I've hand-assembled 100 or so lines of 6502 code, but I wouldn't even think of hand-assembling more than one line of 68000 code. Each instruction must be coded on a bit-by-bit basis, and the results must be converted to hexadecimal.

The assembler is a line-by-line interpretative routine, invoked by typing the MM (memory modify) command, the starting address, and the DI option. The assembler first disassembles the code at the current location, then prompts the programmer to enter the new instruction to be assembled. The new instruction is then written over the original. This process requires a video terminal because a printing terminal would type the new instruction over the old, resulting in illegible copy. Because it is a line-by-line assembler, labels can't be used in the operand field. Previously defined offsets, however, can be used. For forward references (address unknown), the * can be used. This generates the code for a jump to the location of the operation just assembled. When the entire routine has been written, it can be disassembled and the correct memory location inserted at all instructions that branch to themselves.

The disassembler may be invoked in the same manner as the assembler: it disassembles one line at a time. To get a complete listing, the MD (memory display) command can be used with the DI option (see photo 2). The listing can be directed to all four I/O ports. However, the

Heath/Zenith Users— Get the Information You Need:

Read the only independent magazine with a specific focus on your system—

SEXTANT the Independent Magazine for the Entire Zenith Computer Community.

Whether you use an H/Z100, H/Z89, Z90, H88, or H8—you'll find articles in every issue which apply to your system.

Explore CP/M, HDOS, and Z-DOS capabilities through *Sextant's* articles. Applications, programs, compatible hardware and software, and the latest developments in the Heath/Zenith community are among the topics included in *Sextant* on a regular basis.

Carefully edited to bring you a broad coverage of the Heath/Zenith community, *Sextant* features include:

- A broad range of "how-to" articles which will help you implement system enhancements as you need them. Read about how other users have altered their systems to suit their needs—and how you can do the same.

- Reviews of products from Zenith and independent suppliers will help you sort out the questions you have about hardware and software options you might consider.

- Short program listings, including utility programs and games, give you practical options which you can implement immediately.

- For your system needs, you'll find over 90 advertisements of compatible products in each issue of *Sextant*. Many advertisers find the independent magazine for the entire Zenith computer community the most direct medium to market their Heath/Zenith-specific products—you'll find independent suppliers with products you won't find advertised elsewhere.

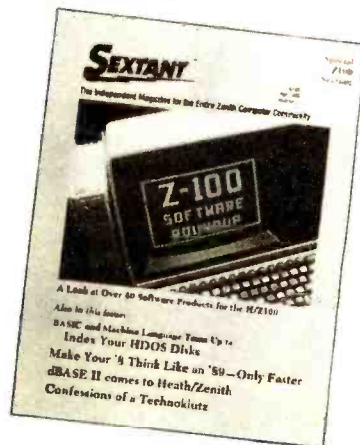

- And, so that you'll be informed of the latest progress and innovations in your Heath/Zenith community, *Sextant* provides extensive coverage of community affairs. Read about major events in the Heath/Zenith community, as Heath/Zenith users meet to discuss recent developments and future projections. Specific companies and individuals are highlighted as they make significant contributions to the Heath/Zenith community.

A Whole World of Information About Your System, Available to You Now.

Start your subscription today! Call Toll Free: DATAEL™ 800/341-1522

(M-F 8 am-9 pm Eastern Time)

Or send in the coupon below to: Sextant, Dept. B, 716 E Street S.E., Washington, DC 20003 • 202/544-0900



Your satisfaction with *Sextant* is guaranteed. If at any time you're not satisfied just let us know and your money will be refunded—in full.

Send me:

- 8 issues for \$19.94 (\$23.00 to Canada)
- 4 issues for \$9.97 (\$11.50 to Canada; \$14.00 overseas via surface mail, \$35.00 via air mail)
- Payment enclosed (Checks must be in U.S. dollars payable on a U.S. bank.)
- Bill me
- Charge my: Visa MasterCard (MC code # _____)

Card # _____ Expiration date _____

Name _____

Address _____

Please allow 6 to 8 weeks for delivery of your first issue.

Sextant, Dept. B, 716 E Street S.E., Washington, DC 20003

EXPOTEK

2723 W. Windrose
Phoenix, Arizona 85029

1-800-528-8960

Guaranteed Low Prices

THIS MONTH'S SPECIAL
DAISYWRITER 2000
CALL

for the IBM

TANDON 100-2DD	\$245
QUADRAMCARDS	CALL
16K RAM CHIPS		
SET OF 9	\$1575
64K MEM/UPGRADE	\$80
SOFTWARE	CALL

PRINTERS

CITOH

F1040	\$1090
F1055	\$1499
1550P	\$599
8510P	\$345

COMPUTERS ALTOS

580-10	\$4199
586-10	\$5498
586-14	\$7680
8600-12	\$8399

SILVEREED SAVE \$ CALL

DATASOUTH

DS120	\$595
DS180	\$1169

ATARI SAVE \$ CALL NORTHSTAR

ADVANTAGE	\$2150
W/15MB	\$4310

DIABLO

620	\$895
630RO	\$1710

NEC

3510	\$1365
3550	\$1705
7710	\$1900
8023	\$399

TELEVIDEO

802	\$2515
802H	\$4449
803	\$1845
1603	CALL

OKIDATA SAVE \$ CALL

TERMINALS

ADDS

VIEWPOINT A1	\$485
VIEWPOINT A2	\$550

HAZELTINE

ESPRIT I	\$498
ESPRIT II	\$540

TELEVIDEO

910	\$555
925	\$699
950	\$865
970	\$1015

DISKDRIVES

FOR APPLE		
MICOR SCI A2	\$255
RANA ELITE I	\$260
RANA ELITE III	\$540
FOR ATARI		
RANA 1000	\$375

MONITORS

AMDEK

300 GREEN	\$129
300 AMBER	\$145
310 AMBER (IBM)	\$199
COLOR I	\$275

BMC

GREEN	\$88
COLOR	\$299

APPLECARDS

16K RAM	\$69
Z80	\$235
VIDEX 80 COLUMN	\$227
VIEWMAX 80	\$175
MICROSOFT PREM. PK	\$465

DISKETTES

ELEPHANT SS/SD	\$18.00 BX
SCOTCH SS/DD	\$22.00 BX
DYSAN SS/SD	\$33.00 BX
(100 MIN. ON DISKS)		

ALL PRICES SUBJECT TO CHANGE
CUSTOMER SERVICE (602) 863-0759

software does not support reading anything other than "S" files from the tape recorder, and I have not yet found a way of retrieving disassembled listings from tape.

Motorola does not supply source listings of the Tutor program, which could be a pain for anyone writing I/O routines, but it does support a large number of user-available routines that can be accessed through the TRAP #14 instruction. The TRAP function is the only graceful way to enter supervisor mode from user mode. The function desired is passed as a parameter in register D7. Currently, 28 different I/O and utility routines are available to the user through the TRAP, and 127 additional numbers are available for user-defined functions.

Tutor is the only software available for the ECB. As dedicated software hackers get the board, this situation will change. I plan to purchase the FORTH source code for the 68000, along with the installation manual, from the FORTH Interest Group (FIG).

Documentation

When you first open the shipping container, the board seems dwarfed by the nearly 500 pages of documentation that come with the system (see photo 3). The documentation consists of a 240-page programming manual for the 68000, a 130-page manual for the educational board, and data booklets on the three major LSI (large-scale integration) chips on the board—the MC68000 microprocessor, the MC68230 parallel interface adapter and timer, and the MC6850 asynchronous communications interface.

I've read a lot of computer documentation and have found, as a rule, that Motorola documentation is the most thorough and intelligible. The documentation for the ECB is no exception. Only the source listing for Tutor is lacking. The documentation is not simple because the computer and its software are complex, but so far I haven't come across any problems that couldn't be solved by reading the book. Overall, the material reflects a standard of excellence I would like to see other manufacturers emulate.

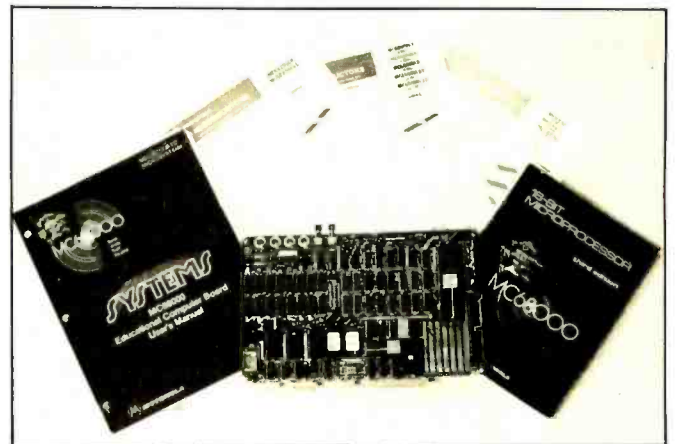

Photo 3: The documentation seems to dwarf the ECB. Clockwise from left are the Educational Computer Board Users' Manual, data books on the MC68230 timer, the 68000, the MC6850 serial interface adapter, and the MC68000 Programmer's Manual.

From Japan's largest computer company. Quality. Value. Performance.



Fujitsu, Japan's largest computer company, introduces its Micro 16s™ personal business computer. The Micro 16s combines Fujitsu's knowledge of semiconductor technology and the step-by-step quality control in manufacturing that's made Fujitsu Japan's number one computer company.

You'll find the Micro 16s is a complete system. Its price includes the CP/M-86® operating system, SuperCalc²™ spreadsheet, WordStar® word processing program, a high resolution color monitor, and both the Z80^A 8-bit and the 8086 16-bit microprocessors.

With the Micro 16s, you can use over 3,000 8- and 16-bit CP/M® software programs available today. In addition, MS™-DOS and the multi-tasking Concurrent CP/M™ are available as options.

Micro 16s performance results from its flexibility of design. The Micro 16s features expansion slots that allow you to add up to one megabyte of memory, hard disks, and local area networking. The design flexibility will also give you the capability to add the advanced 16- and 32-bit microprocessors of tomorrow.

If you're looking for quality, value, and performance in a personal business computer, ask for the Fujitsu Micro 16s. For more information, call toll free 1-800-MICRO 16. Or write Fujitsu Microelectronics, Inc. Professional Microsystems Division, 3320 Scott Blvd., Santa Clara, CA 95051.



FUJITSU

CP/M and Concurrent CP/M are trademarks of Digital Research Corporation. SuperCalc² is a trademark of Sorcim Corporation. WordStar is a registered trademark of MicroPro International. MS is a trademark of Microsoft. Z80 is a registered trademark of Zilog, Inc.



Photo 4: The ECB fits neatly into a Heathkit H-19 terminal. Regulated power is obtained from the H-19 through the wires in the upper left. The serial output of the terminal goes directly to the ECB, and the host port of the ECB is wired to the serial output port of the H-19. Separate holes punched in the rear chassis are for the cassette and disk I/O connectors.

Homebrew Capabilities

Although the board is designed primarily for educational purposes, it has great potential as the basis of a

homebrew project. In fact, that was my prime motivation in buying the board. Because it starts out with an excellent monitor, 32K bytes of RAM, and some basic I/O functions, I was already on the way to having a system with reasonable capabilities.

I wanted video capabilities, so I installed the board inside a Heathkit H-19 terminal (see photo 4). The ECB draws only a few watts, thus there is no problem with it using the H-19 power supply. The serial output of the H-19 board goes directly into the ECB board, and port 2 of the board hooks to the DB-25 connector on the back. In this way, the system acts like a normal H-19 terminal when the program is in transparent mode.

Because I soon tired of loading programs from tape and had an old 8-inch disk drive I had picked up at a swap meet, I decided to construct a disk controller. The design I used is a modification of Nicholson and Camp's "Super Simple Floppy-Disk Interface" (see May 1981 BYTE, page 360). The interface turned out to be even simpler on the ECB because the 68000 is fast enough to perform some functions in software that had been implemented in hardware on the original design.

Conclusions

If you are interested in learning about the 68000, and particularly about 68000 assembly language, the ECB is hard to beat. Even if you already have a 68000 development system, the ECB is valuable for writing and testing short routines.

The monitor program alone, which includes an assembler and disassembler, is worth the price of the board. I expect a 16K-byte monitor to be very powerful, and this one is.

The Motorola documentation is excellent but lacks a source listing of the monitor program. However, most of the important I/O and conversion routines are available through the TRAP #14 function. ■

Robert W. Floyd (1123 Kainui Dr., Kailua, HI 96734) works as a physicist at the Naval Ocean Systems Center, Hawaii Laboratory.

C compilers

HOST	6809 TARGET	PDP 11*/LSI 11* TARGET	8080/(Z80) TARGET	8088/8086 TARGET
FLEX*/UNIFLEX* OS-9*	\$200.00 \$350.00	500.00	500.00	500.00
RT 11*/RSX 11* PDP-11*	500.00	200.00 350.00	500.00	500.00
CP/M* 8080/(Z80)	500.00	500.00	200.00 350.00	500.00
PCDOS*/CP/M86* 8088/8086	500.00	500.00	500.00	200.00 350.00

*PCDOS is a trademark of IBM CORP. MSDOS is a trademark of MICROSOFT. UNIX is a trademark of Bell Labs. RT-11/RSX-11/PDP-11 is a trademark of Digital Equipment Corporation. FLEX/UNIFLEX is a trademark of Technical Systems consultants. CP/M & CP/M86 are trademarks of Digital Research. OS-9 is a trademark of Microware & Motorola.

• FULL C

• UNIX* Ver. 7 COMPATABILITY

• NO ROYALTIES ON GENERATED CODE

• GENERATED CODE IS REENTRANT

• C AND ASSEMBLY SOURCE MAY BE INTERMIXED

• UPGRADES & SUPPORT FOR 1 YEAR C SOURCE AVAILABLE FOR \$2500⁰⁰

408-275-1659

TELECON SYSTEMS
1155 Meridian Avenue, Suite 218
San Jose, California 95125



ALL THE HARD PART IS MAKING SURE MINI DISKS COME ERROR FREE.

THEY STAY THAT WAY.

A disk is built with certain safeguards. That's why most disk makers offer guarantees that the product you receive comes to you error free.

We at Memtek Products are concerned that the minidisk remains error free. *Every* time you use it. After exposure to dust, cigarette smoke, fingerprints, even wear caused by your computer. And so, we have built safeguards around the disk, as well.

Memtek Products' latest innovation... acknowledgment of a real world beyond the laboratory.

The hub ring. Designed to prevent our minidisks from jamming in your machine. Rigid. Durable. Reinforced.

The coating. A critically-controlled coating of high-energy magnetic oxide particles that covers the disk's surface, which is then micro-polished to improve head to disk contact, preventing dropouts, lowering head abrasion.

The lubrication system. A constant lubricant protects both the disk surface and the drive head from wear.

The sleeve. Comes with a soft liner that protects the disk while gently cleaning the surface.

The guarantee.

We'll replace, free, any minidisk if it fails to accurately store and retrieve data due to a defect in materials or workmanship for up to 5 years from date of purchase. Simply mail the disk back.

The Memtek lineup.

Premium, double and quad density minidisks as well as 10- and 15-minute computer cassettes and a 5 1/4" disk drive head cleaner.



WE PLAY FOR KEEPS™



Construction Costs Profile

- 1 - Materials (24%)
- 2 - Labor (27%)
- 3 - Overhead (22%)
- 4 - Land (27%)



Only the Texas Instruments Professional Computer offers these 7 advantages that add up to more computer for your money.

If you're a smart business professional, you want a business computer that gives you the most productivity power for your dollar. For you, Texas Instruments has the answer: the TI Professional Computer. With seven obvious advantages that make buying TI make sense.

The Disk Storage Advantage.

The TI Professional Computer gives you standard 320K floppy disk storage. That's twice the standard data storage of the leading competitor.

The Function Key Advantage.

We give you 12 function keys that you can easily preprogram to make your work simpler and easier. The best the competition can do is 10 or fewer function keys.

The Keyboard Advantage.

Our standard touch-typing layout makes word processing as easy as sitting at a typewriter. The separate numeric and cursor control keypads let you isolate information and enter numbers for spreadsheets more quickly. And with our isolated edit/delete keys, you'll never have to

worry about accidentally erasing valuable data.

The Monitor Advantage.

Our monitor gives you 40-50% better resolution than the leading personal computers. Which means you get clearer displays that are easy on the eyes. And some of the sharpest graphics possible today.

The Software Advantage.

There's software available now for the TI Professional Computer that meets virtually every professional and small business need. And with our memory expansion board, you can use advanced integrated software like Lotus 1-2-3™ to help you do several kinds of work without changing programs.

The Expandability Advantage.

Our standard features like the floppy disk controller and printer support are built-in so they don't take up the valuable expansion slots you'll need for adding optional features like communications and up to ten megabytes of hard-disk storage. Which leads to one of our most exciting advantages...

The Future Enhancement Advantage.

No one wants to buy a personal computer that's already on the road to obsolescence. That's why we're developing exciting new features that you can easily add to your TI Professional Computer—like speech recognition. Imagine being able to say, "Spreadsheet, please" and having it appear instantly on your monitor. This and more will be available this fall.

One additional benefit makes the TI Professional Computer especially attractive — the price. Feature for feature, dollar for dollar, you'll get more computer for your money.

Get the business computer that puts these benefits to your advantage. Visit your TI authorized dealer or write: Texas Instruments Data Systems Group CA, Dept. 062BY, P. O. Box 402430, Dallas, TX 75240. Or call toll-free: 1-800-527-3500.



TEXAS INSTRUMENTS

Creating useful products
and services for you.

You don't need a computer to talk to another computer.

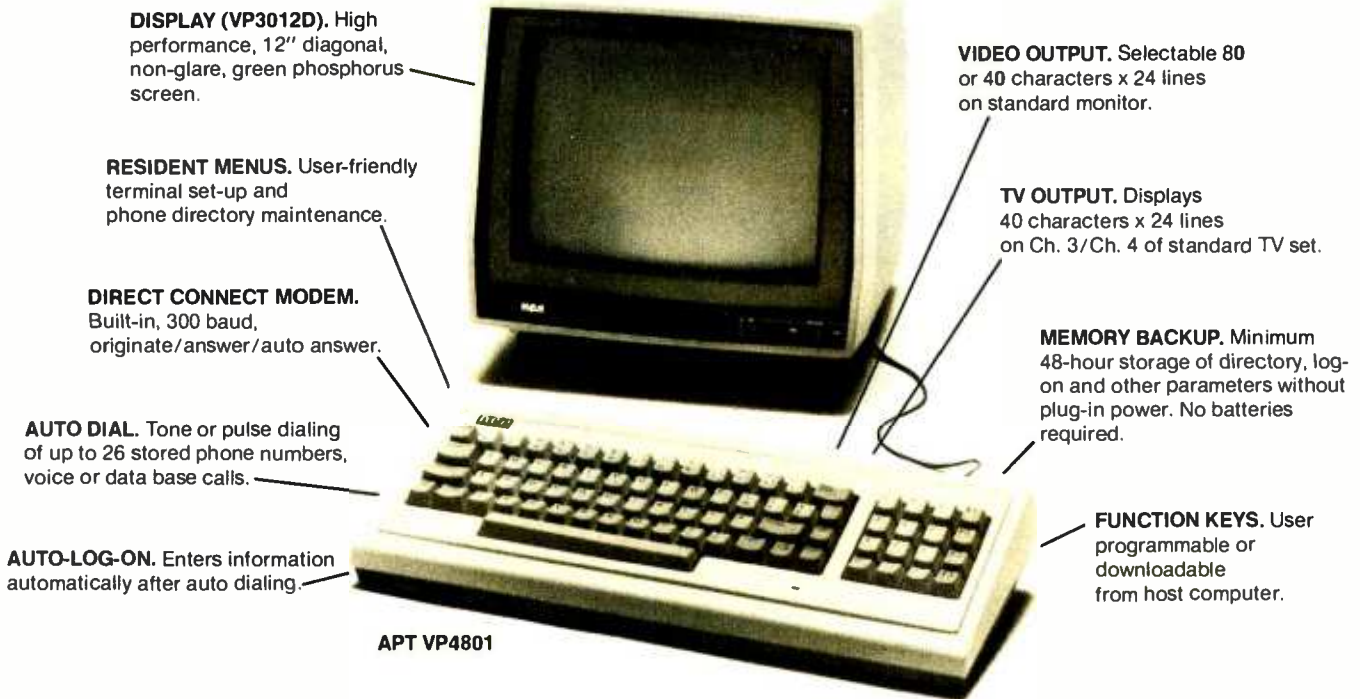

The new RCA APT (All Purpose Terminal) expands your data communications capabilities for a lot less money.

For business, professional and personal data communications, you'll find more user-friendly features and greater communications capabilities in the RCA APT than in other terminals selling for up to three times the price.

The new APT terminals are ideally suited to multi-data base time sharing and dedicated, direct computer-connected applications. They feature menu-controlled operation and a programmable "personality" to match specific communications requirements for your data bases.

A single keypress can dial a stored number, send the log-on sequence to the host computer, and return terminal control to the user. Password protection prevents unauthorized access to designated numbers. APT can also be used as an auto-dialer for voice communications.

OTHER FEATURES

RS232C port for direct computer connections at data rates to 9600 baud, or for connecting high speed modems and other accessories. Parallel printer port for hard copy. Numeric keypad, can dial phone numbers not in terminal directory. Built-in speaker with adjustable volume control for audio monitoring of phone line. Smooth scroll display. Automatic screen blanking to reduce possibility of burn. Briefcase size: 17" x 7" x 2". Weight: under 4 lbs.

Quite simply, matching features with price, there is no other professional quality terminal available today that can do as much at such low cost.

APT terminals list for \$399, in your choice of full stroke or membrane keyboard versions. Either style is also available with a display monitor for \$598 list. The data display monitor alone, VP3012D, \$229 list.

For more information—or to order—call 800-233-0094. In Penna., call collect to 717-393-0446. Or write for fully descriptive brochure to RCA MicroComputer Products, New Holland Avenue, Lancaster, PA 17604. OEM and dealer pricing available. The new RCA APT. Expansive. Not expensive.

APT VP3801. Flexible membrane keyboard version designed for travel and hostile environments.

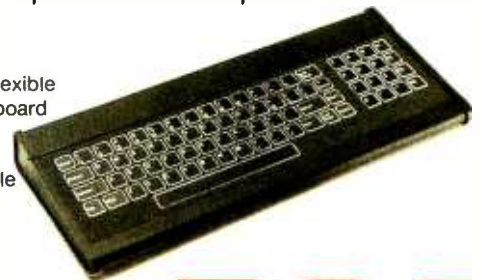

RCA

Fancy Font

Increase the versatility of your Epson printer

by Paul E. Hoffman

Since before the age of wooden presses, typographers have been concerned with designing typefaces to suit specifications and tastes; that concern continues in this day of dot-matrix machines. Softcraft has released a program called Fancy Font that lets Epson printer users design their own type styles.

Epson printers, because they use dot-addressable graphics, are capable of considerable versatility; however, modifying your own program to directly control each pin in the Epson's print head is a difficult and time-consuming task.

With the Fancy Font system, you can alter the size and style of characters and create unique symbols. This easy-to-use package runs under CP/M-80 or PC-DOS and works with any MX-80, MX-100, FX-80, or FX-100 printer. (The MX series must have Grafrax graphics chips; all

FX printers come with the Grafrax installed.) With just a few additions to your text files, you can print in roman, italic, sans serif, Old English, script, or a font of your own design.

Fancy Font achieves a very high quality print by using the Epson's dot-addressable characteristics—it prints the necessary dots for each line, moves down a fraction of a dot-width, prints the line again, and so on, six passes per line. Although this procedure makes printing your final draft quite slow, the output is significantly more attractive than the standard type style available.

The people at Softcraft have apparently gone to great lengths to make Fancy Font a usable program; they've packaged extensive command-line options, help messages at all prompts, informative error messages, and, most important, a complete and well-written users manual for \$180. The market for Fancy Font includes anyone with a CP/M-80 or PC-DOS machine and an Epson printer who wants a variety of type styles.

Features of Fancy Font

Fancy Font, loaded with features, lets you customize output to fit your needs. As a result, you can actually come up with new uses, instead of a list of wishes, for the system. This flexibility is important to anyone who uses a computer for different applications.

One of the package's most apparent features is the number of predefined fonts it offers. The 33 font files (see table 1) provide enough latitude that you will probably never need to define your own font. The fonts are very well designed and resemble closely the type from a standard typesetter; examples of each font are shown in figure 1.

You can have as many as 10 fonts active at any one

Style	Sizes
Roman regular	8, 10, 11, 12, 18, 40
Roman italic	10, 11, 12, 18
Roman bold	10, 11, 12, 18
Roman subscript	8
Roman superscript	8
Sans serif regular	8, 10, 11, 12, 18
Sans serif italic	12
Old English	18, 20, 40
Script	12, 14, 18, 20, 40
Special characters	12, 20, 40

Table 1: Sizes of fonts supplied with Fancy Font. All sizes are given in points; 1 point is equal to 1/72 of an inch.

These are Roman regular, *Roman italic*, and **Roman bold**. Many people prefer the Sans Serif regular or *Sans Serif italic*, but the most proper and high-minded among us prefer Script or even **Old English**.

Figure 1: Samples of the type styles provided with Fancy Font.

time. Fancy Font tries to load into memory as many fonts as possible in order to reduce disk access time, but it will swap fonts in and out of memory as necessary. You probably won't use more than three or four type styles in any one document, but you might have many files with the special symbols and characters you create, and you may want to use different sizes of one style for things such as headings, body, and footnotes.

You need to make only minor modifications to your current text files to accommodate Fancy Font. All formatting commands are given with a backslash and can be inserted in-line. The commands let you space vertically on the page with accuracy to 1/72 of an inch, space horizontally with accuracy to 1/120 of an inch, justify text, substitute strings specified on the command line, and a host of other functions (see table 2).

Tables are especially easy to format with Fancy Font because you can specify both relative movements (from your position on the page) or absolute movements (from the top or left margin).

Command	Description
fn	Switch to font number n
vn	Move down n/72 inches
wn	Move to n/72 inches from the top of page
h	Move right by 1/120 of an inch
in	Move right n/120 inches
an	Move to n/120 inches from the left margin
p (or ^ L)	Go to next top of page
t (or ^ I)	Move to next tab stop
u	Toggle underlining
c	Center the current line
r	Make the current line flush right
b	Break the current line
j	Turn on justification
k	Turn off justification
dn	Print ASCII character n
sn	Substitute string number n
s#	Substitute the current page number
sf	Substitute the current filename

Table 2: Formatting commands in Fancy Font. These commands may appear anywhere on a line of text. They are all preceded by a backslash (e.g., \c).

Because Fancy Font works with any text editor, you can type in the text you want to print, then add the formatting commands afterward. Unfortunately, Fancy Font does not format paragraphs, so each line has to be the right length; however, with the justification command, there is a reasonable amount of leeway. Many text editors let you set the margins for their own paragraph filling; you can simply adjust these to the ones you choose in your Fancy Font output.

People rarely agree on how they like their text to look, so Softcraft has included an editor that lets you change the characters provided. Though it's not quite as easy to use as the formatting program, the new user can pick it up fairly quickly. The program lets you modify existing fonts and create your own. Figure 2 shows three letters as they appear on the distribution disk and after modification using Fancy Font. It took less than two minutes to make the changes. To modify characters, you choose a character set for the originals and instruct Fancy Font to save each character as a file of asterisks, each asterisk representing a dot to be printed. You then edit each file, asterisk by asterisk, shaping the letters to your preference; for example, you can add asterisks to make characters bolder or wider and remove asterisks to make characters lighter or more narrow.

You may want to create special characters that do not correspond to ASCII (American National Standard Code for Information Interchange) codes. The Fancy Font system contains a program called Cfont that lets you select characters from the Hershey set, a collection of graphics symbols and letters, and insert them in your own fonts. Of course, you can also modify these characters the same way you modify the ASCII characters.

Figure 3 shows an AND gate in a shaded box and the input to the formatter that made the figure. The gate was created with a text editor, and the shaded box was supplied as a combination of the characters in one of the special fonts. In font 0 (the supplied special-character font), b makes the vertical line and g makes the box. In font 1 (created with the electronic symbols), A generates the AND gate.

With the Hershey set's four type styles and almost 1600 symbols (including Greek, Hebrew, and Russian characters), you may think you have all the printing characters you would ever want. One of the nicest features of Fancy Font is that its writers knew this would not be the case and that you would want an easy way to create your own characters.

PENPAD[®] draws circles around a keyboard and a mouse.



Here are just a few ways PENPAD[®] can be used:

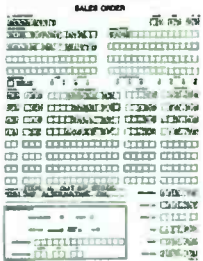

ORDER ENTRY



CONTROLS AT THE TOUCH OF A PEN

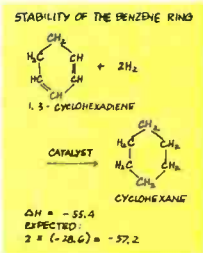

SCIENTIFIC EQUATIONS

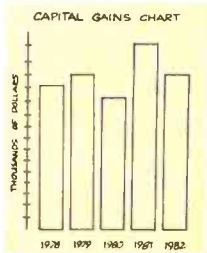

INDUSTRIAL AND BUSINESS GRAPHICS

Only PENPAD[®] allows you to perform the functions of a keyboard, mouse and graphics tablet with a single, friendly means of input—a pen.

Only PENPAD[®] has Dynamic Character Recognition which converts your own handwriting into characters and displays them on the screen as if they were typed on a keyboard.

Only PENPAD[®] lets you compose text and graphics on the screen simultaneously. It combines the freehand capability of a multi-color high resolution graphics tablet with Dynamic Character Recognition and enables you to switch between text and freehand modes instantly.

Only PENPAD[®] puts the cursor in your hand at the point of your pen. Write anywhere or touch user-programmable function areas on the tablet. You can design function areas in any size or location on the pad and point to objects and icons at the touch of a pen.

Not only can PENPAD[®] draw circles around a keyboard and a mouse, it also lets you enter text by handprinting, select your own commands, use objects and icons, and sketch out rough ideas...all with one hand tied behind your back.

- PENPAD[®] works with most popular PC's like IBM, Apple, Wang, DEC, Seiko, and others.
- Software product developers call for special opportunities.

Circle 355 on inquiry card.

Before Fancy Font begins formatting your text, you can give commands that set margins, substitute strings, and print the copy you need. You can give these parameters (see table 3) on the CP/M or PC-DOS command line, have them stored in the PFONT command file for repetitive use of the formatter, or enter them interactively.

The interactive input for these parameters is especially easy to use; every software company should be as helpful in guiding users as Softcraft is. At any prompt, you can type a ? to get more information about what your options are at that point. You can also type a & to find out all of the current values, a < and a filename (a la Unix) to get more parameter commands from a command file, a Control-V to get a general help message, or a Control-C to quit (the system asks if you are sure before tossing you back to the operating system).

While your file is printing, you can abort the printing of an individual page by typing a Control-P, abort the rest of the current file by typing a Control-F, or abort printing completely by typing a Control-C. Perhaps this seems like an excessive number of features, but once you start using Fancy Font you will probably want them all.

Disadvantages

Fancy Font is a very useful program; however, it has two disadvantages. First, because the program requires six passes over each line (and prevents the printer from running bidirectionally), it takes an incredibly long time to print anything. Second, the formatter does not know

Old:
New:

XYZ
XYZ

Figure 2: The top line shows characters from the distribution disk. The bottom line shows those characters modified using Fancy Font.



\f0bgb \a0003 \f1A

Figure 3: An AND gate in a shaded box and the line of text used to produce it. The AND gate was designed with a text editor and made part of a font of electronic symbols.

At a Glance

Name

Fancy Font version 1.7

Type

Text formatter for enhanced printing with Epson printers

Manufacturer

Softcraft
8726 South Sepulveda Blvd., Suite 1641
Los Angeles, CA 90045
(213) 821-8476

Price

\$180

Format

5¼- or 8-inch floppy disk for CP/M, Apple CP/M, Kaypro, Epson QX-10, Osborne, and IBM PC-DOS; files can be transferred to a hard disk

Computer System

CP/M-80-based system with 48K bytes of usable RAM or IBM PC with PC-DOS; Epson MX-80, MX-100, FX-80, or FX-100 with Graf-trax PROMs; full 8-bit parallel or serial printer interface

Documentation

94 pages, including nine appendixes and a table of contents

Audience

Users who want high-quality, fancy printing from an Epson MX-80, MX-100, FX-80, or FX-100

Command	Description
FI	Name of file(s) to print; up to 15 may be specified
FO	Name of fonts to use; up to 10 may be specified
RD	Rough draft mode; this allows two faster, but lower-quality, print modes
EP	Use normal Epson fonts, including compressed, expanded, double-strike, etc.
SD	Screen display
SU	Strings to substitute for
FP	First page to print
LP	Last page to print
CF	Concatenate files without a page break
LM	Left margin
SP	Spacing between lines
TM	Top margin (between page top and text)
BM	Bottom margin (between text and page bottom)
HM	Heading margin (between page top and header)
FM	Footling margin (between footer and page bottom)
PL	Total page length in inches
LW	Line width
HL	Heading line for top of page
FL	Footling line for bottom of page
NF	Suppress header and footer on first page
PP	Pause between pages for paper insertion
PF	Process formfeeds
PN	Initial page number
CI	Change command indicator
IS	Set initialization string
PG	Enable vertical margins
TB	Set tab stops

Table 3: Parameters to the PFONT command.

Taxan monitors when precision counts

Dedicated to quality and precision, TAXAN offers a complete line of monitors including green and amber, ultra-high resolution monochrome, plus medium and high resolution RGB monitors.



⊗ TAXAN also offers the 410-80, 80 column and RGB card to interface with the Apple IIe.

⊗ TAXAN monitors stand alone.

See your local ⊗ TAXAN dealer, or call us for details!

⊗ **TAXAN**

TSK Electronics Corporation

18005 Cortney Court

City of Industry, CA 91748

(213) 810-1291

Circle 483 on inquiry card.

TANDON Blow Out!

Tandon
TM-55-2
..... **\$229⁰⁰**

Tandon
TM-100-2
..... **\$229⁰⁰**

(Please Limit 4 Drives Per Order)
— Offer Expires 11/15/83 —

“THE COMPUTER-LINE”

Product Information & Order Lines:

California

1-800-255-4659 / 1-213-716-1812

Colorado

1-800-525-7877 / 1-303-279-2848

Customer Service & Order Inquiry:

1-213-576-6468

Open 7 Days A Week

Mon.-Fri. 7 am to 8 pm / Sat.-Sun. 8 am to 6 pm

how to wrap paragraphs; the lines in your input file must be the correct length when you run the formatter.

The lack of paragraph wrap is a program deficiency I hope will be rectified in future releases of Fancy Font. Although Softcraft claims you can generally guess the correct line length, you will more than likely need to go through two rough drafts to get the line lengths right. It would be much handier for Softcraft to simply figure out how many characters can fit on a line (accounting for differences in character sizes) and break the line at the nearest word.

The slow printing speed is necessary for Fancy Font to produce high-quality type. To partially alleviate this problem, Softcraft gives you three choices of type for rough drafts: two lower-density print modes and the straightforward Epson typeface. You can look at rough drafts of your work, then print out the final copy later. The two rough-draft modes run about three and four times faster than the final draft mode but about half as fast as the Epson font mode. In the high-quality mode, it takes 10 to 15 minutes to type an average page of text.

Documentation

As you would expect from a program with an excellent user interface, the manual is clear and easy to read. The text begins with an example of how to start printing with Fancy Font and explains all options and parameters in detail.

The nine appendixes cover everything from using Fancy Font with Wordstar to the internal formats of the font files. They also show samples of the different type styles and all of the characters in the Hershey set. The back cover serves as a reference card for the formatter parameters and options.

The people at Softcraft, very responsive on the telephone, are more than willing to answer detailed technical questions.

Conclusions

Fancy Font will give your CP/M-80 or PC-DOS computer a new way to present text. The system's resolution is quite good (it can be improved by reducing the printed output with a photocopier), and the program is very easy to learn and use.

Although the final output takes a significantly long time to print, its high quality is usually worth the wait. Also, being able to design your own characters and symbols frees you from having to cut and paste them on printed pages.

The number of Fancy Font's print features is impressive. For anyone with an Epson printer, Fancy Font's ease of use makes it a package worth considering. The price of the package is fair compared to others on the market, and its capabilities make it a very good buy. ■

Paul E. Hoffman, president of Proper Software (Suite 1024, 2000 Center St., Berkeley, CA 94704), writes manuals for many microcomputer companies in the San Francisco area.

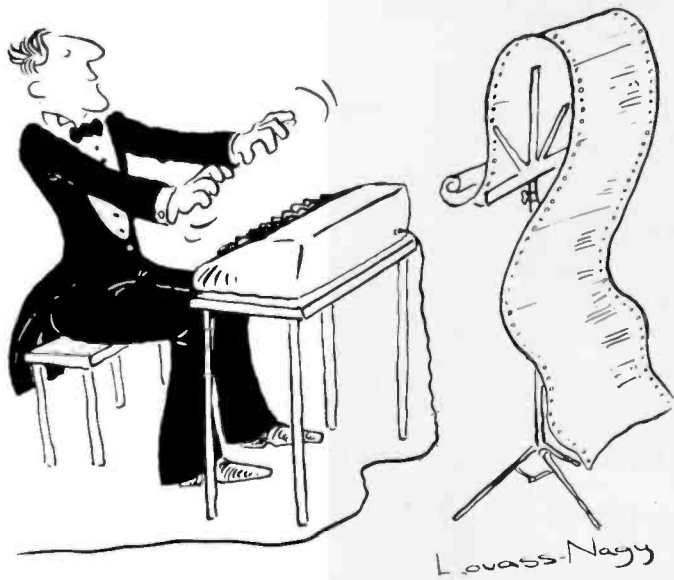

Before Johann Sebastian Bach developed a new method of tuning, you had to change instruments practically every time you wanted to change keys. Very difficult.

Before Avocet introduced its family of cross-assemblers, developing micro-processor software was much the same. You needed a separate development system for practically every type of processor. Very difficult and very expensive.

But with Avocet's cross-assemblers, a single computer can develop software for virtually any microprocessor! Does that put us in a league with Bach? You decide.

The Well-Tempered Cross-Assembler

Development Tools That Work

Avocet cross-assemblers are fast, reliable and user-proven in over 3 years of actual use. Ask NASA, IBM, XEROX or the hundreds of other organizations that use them. Every time you see a new microprocessor-based product, there's a good chance it was developed with Avocet cross-assemblers.

Avocet cross-assemblers are easy to use. They run on any computer with CP/M* and process assembly language for the most popular microprocessor families.

5 1/4" disk formats available at no extra cost include Osborne, Xerox, H-P, IBM PC, Kaypro, North Star, Zenith, Televideo, Otrona, DEC.

Turn Your Computer Into A Complete Development System

Of course, there's more. Avocet has the tools you need from start to finish to enter, assemble and test your software and finally cast it in EPROM:

Text Editor VEDIT -- full-screen text editor by CompuView. Makes source code entry a snap. Full-screen text editing, plus TECO-like macro facility for repetitive tasks. Pre-configured for over 40 terminals and personal computers as well as in user-configurable form.

CP/M-80 version \$150
 CP/M-86 or MDOS version \$195
 (when ordered with any Avocet product)

ROM Simulator -- ROMSIM by Inner Access eliminates need to erase and reprogram EPROM. Installed in an S-100 host, ROMSIM substitutes RAM for EPROM in external target system. 16K memory can be configured to simulate the 2708, 2758, 2716, 2516, 2732, 2532, 2764, 2564 in either byte or word organization. Avocet's configurable driver makes loading of HEX or COM files fast and easy.

From \$495 depending on cabling and RAM installed.

Avocet Cross-assembler	Target Microprocessor	CP/M-80 Version	CP/M-86 MSDOS** IBM PC Versions	
XASM05	6805	\$200.00 each	\$250.00 each	
XASM09	6809			
XASM18	1802			
XASM48	8048/8041			
XASM51	8051			
XASM65	6502			
XASM68	6800/01			
XASMZ8	Z8			
XASMF8	F8/3870			\$300.00 each
XASM400	COP400			\$500.00
XASM75	NEC 7500			
(Coming soon: XASM68K...68000)				

EPROM Programmer -- Model 7128 EPROM Programmer by GTek programs most EPROMS without the need for personality modules. Self-contained power supply... accepts ASCII commands and data from any computer through RS 232 serial interface. Cross-assembler hex object files can be down-loaded directly. Commands include verify and read, as well as partial programming.

PROM types supported: 2508, 2758, 2516, 2716, 2532, 2732, 2732A, 27C32, MCM8766, 2564, 2764, 27C64, 27128, 8748, 8741, 8749, 8742, 8751, 8755, plus Seeq and Xicor EEPROMS.

(Upgrade kits will be available for new PROM types as they are introduced.)

Programmer \$389
 Options include:
 Software Driver Package \$ 30
 RS 232 Cable \$ 30
 8748 family socket adaptor \$ 98
 8751 family socket adaptor \$174

Call Us

If you're thinking about development systems, call us for some straight talk. If we don't have what you need, we'll help you find out who does. If you like, we'll even talk about Bach.

VISA and Mastercard accepted: All popular disc formats now available -- please specify. Prices do not include shipping and handling -- call for exact quotes. OEM INQUIRIES INVITED.

*Trademark of Digital Research **Trademark of Microsoft



AVOCET SYSTEMS INC.™

DEPT. 1083-B
804 SOUTH STATE STREET
DOVER, DELAWARE 19901
302-734-0151
800-448-8500
TLX 467210

BHART BEST PRICES

BUY OF THE MONTH BMC 800 mod. 20 A Unique Computer at a Unique Price



Made by Okidata in Japan, with all the quality you have come to expect from this manufacturer, and unique features to appeal even to the most discriminating buyer:

Completely integrated computer: Z-80A CPU (optional: 8086 CPU) 64K - 1 MB RAM, 2 Floppies 800 KB (optional: 2 removable Hard Discs 12.3 MB), 12" display (mono/color), optional light pen, high-res. graphics (8 shades grey/8 colors), ROM port w/EPROM programming capability, clock & calendar, AND a 140 CPS dot-matrix printer built-in: A complete screen dump requires only a single key press, and your most intricate graphics are immediately reproduced on plain paper! Standard software included: CP/M, BASIC, WordStar, SpellStar, MailMerge, CalcStar. Computer, built-in printer & all other features listed above:

- Monochrome Model; LIST \$1995 **\$1795**
- Color Model; LIST \$2995 **\$2595**

BURROUGHS B-20

Most advanced multi-user, multi-tasking micro on the market: Beats many mini's, yet priced comparable to many 8-bit systems.

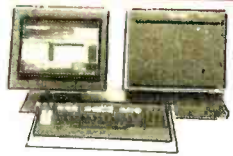

16-bit, 128K-512K RAM, supports up to 16 intelligent workstations with no degradation. Hard disk up to 76 MB, 9-track MTU (mainframe-compatible) option. Mini-like operating system & utilities. Extensive Burroughs & 3rd-party business software, outstanding word-processing, telecommunications & terminal emulation (All Burroughs software include training diskettes & "Help" screens).

- B-21-6 Master/workstation incl. display, 1 Floppy & 15 MB Hard Disk. Oper. Sys. & choice of BASIC/Pascal/COBOL/Fortran incl. List \$8745
 - B-22-CP Cluster workstation, 132 col display!, high-res. graphics. List \$4595
- All B-20 systems installed on your site. Nationwide Burroughs on-site service at extremely low cost. Dealer inquiries invited.

FLOPPY DISKETTES

The very lowest prices for NAME BRANDS: scan this magazine or any other publication and prove it for yourself!
All prices below of first-quality diskettes, reinforced hub, individual envelopes, original factory boxes of 10 (no "private label" rejects or "generics"!).

	LIST	SPECIAL
NASHUA 5 1/4" s.s., s.d.	\$3.55	\$1.49
NASHUA 8" s.s., s.d.	4.00	1.84
All NASHUA diskettes carry unconditional 5-year Manufacturer's Warranty!	3.98	1.89
CONTROL DATA 5 1/4" s.s., d.d.	4.20	1.99
3-M 5 1/4" s.s., d.d.	6.00	2.99
3-M 5 1/4" d.s., d.d.	5.55	2.79
3-M 8" s.s., d.d.	7.10	3.49

Minimum Order 5 boxes (add 20% for 1-4 boxes), add 5% for credit cards or for purchase orders from approved organizations.

SOFTWARE

	LIST	YOUR PRICE	LIST	YOUR PRICE
MS-DOS & APPLE & CP-M				
Multipian	275	179	The Home Acct.	75 51
MultiTool Budget Anal.	150	111	General Accounting	395 288
Supercalc	195	129	Screenwriter II	129 94
Wordstar	495	263	Sensible Speller	125 83
QuickCode	295	212	Bank Street Writer	70 51
dBASE II	700	391	PFS: File	125 83
ZORK I, II, III	49	39	PFS: Report	125 83
			PFS: Graph	125 83
			VisiCalc 3.3	250 186
MS-DOS & APPLE				
VisiCalc	250	179	Advanced Visicalc (Apple III)	400 315
VisiSchedule	300	218	VisiFile	250 186
VisiTrend-Plot	300	218	Eduware (all)	CALL
Versa-Form	389	256	Desktop Plan 3.3	250 189
SuperText Prof.	175	88	Modifiable D/Base	90 59
Personal Investor	145	105	D/B Master	229 160
MS-DOS & CP/M				
Friday	295 ¹⁹⁶		Word Processors:	
Dow-Jones Conn.	50	36	Spellstar	295 180
Cache/Q		CALL	Mailmerge	295 180
Encryptor		CALL	Supersort	195 180
Citation		CALL	BONUS PACK	990 ⁴⁵⁵
SpellBinder	495	274	(Includes: Wordstar & M/Merge)	
Final Word	300	215	Word Handler	199 139
BSTAM	200	144	Games:	
MS-DOS				
PeachText 5000	395	258	Cannon Ball Blitz	35 25
Lotus 1-2-3	495	357	Eggs II	30 21
ATI Power (PC)	75	357	Frogger	35 25
ATI Power: Wordstar/Supercalc/MBasic/Multi-Plan/VisiCalc/dBASE/Easy-Writer II/Easy Filer (each)	75	54	Kamikaze	35 27
Target Fin. Model	325	253	Master Type	40 27
Condor I Database	295	212	Olympic Decathlon	29 23
Condor III Database	650	468	Robot Wars	40 24
Home Acct. Plus	150	104	Wizardry	50 35
1st Class Mail	124	89	CP/M (Most Formats)	
Property Management	495	345	CP +	150 109
Write On	129	89	Random House Thes.	150 109
Real Estate Invest.	129	94	dPATCH	195 129
Random House Thes.	150	109	MicroLab File Lib.	295 195
Money Decisions	199	144	ATI-Pwr. for CP/M	75 54
Deadline	39	36	ATI Power: WordStar/Supercalc/dBASE/Multi-Plan/MBASIC (each)	75 54
Star Cross	39	36	Financial Planner	700 499
PC Text	100	70	Bottom Line Strat.	400 289
Window	150	109	Cardbox	245 174
Wordtrix	34	25	PlannerCalc	99 74
Joysticks (Kraft Sys.)	69	49	Target Fin. Modeling	325 254
Mince	175	160	Palantir Word Proc.	425 309
Final Word	300	215	FMS-80	995 599
Scribble	175	159	Citation card file	250 169
Cross Talk	195	149	Supervyz	150 90
StatPack	495	359	Micro B +	260 209
The Word Plus	150	108	Smart Key	60 46
The Personal Investor	145	99	Smart Print	35 28
RM/COBOL	950	684	Quick Screen	149 123
RM/COBOL Runtime	250	179	dGRAPH	295 217
Job Cost System	495	359	dUTIL	99 84
File Manager Plus	149	109	Prof. Time Acct.	595 439
Advanced Visicalc	400	309	SuperFile	195 117
VisiWord	375	292	Deadline	59 42
VisiSpell	225	176	Star Cross	49 36
Desktop Plan	300	229	Mathemagic	99 74
VisiDex	250	219	Pascal Z	450 378
Bus. Forecast Models	100	79	Pascal BZ (bus. ver.)	450 378
Move-It	150	99	Benchmark	499 359
Wordmate	495	327	Benchmark mailist	250 179
PFS: File	140	93	CIS Cobol	850 612
PFS: Write	140	93	FORMS 2	200 144
PFS: Graph	140	93	FORTH 79	139 109
VisiWord	375	292	CROSSTALK	195 153
VisiFile	300	223	ZIP (C or M-BASIC)	160 104
StarBurst	226	195	ZIP for both C- and M-BASIC	225 142
Pie Writer	199	132	StatPack	495 357
DataFax	299	214	The Word Plus	150 108
Koala Pad	150	108	Textwriter III	125 108
Home Acct.	150	108	Databook	295 229
Logo (Dig. Res.)	149	108	Milestone	295 229
Graph (Dig. Res.)	400	288	Job Files (Proj. Cost)	500 360
			Pearl 1	49 32
			Pearl 2	295 179
			Pearl 3	495 297
			Personal Pearl	295 179
			The Quad	495 419
			Quick N Easy Pro	395 284
			MailMan	125 94
			Quick 'N Easy Gen.	295 214
			CRT FORM	400 289
			Encode/Decode	100 74
			Diagnostic II	125 89
			Term II	200 144
			Disk Doctor	100 72
			Disk Edit	100 74
			Scratch Pad	295 209
			Move-It	125 94
			Money Mgr.	125 94

The Universal Computer

RÖMAR II—Runs Applesoft & CP/M!
6502 CPU for Applesoft, and Z-80 adapter card for CP/M. 64K RAM. 72 keys in standard keyboard. 8 expansion slots accept standard APPLE cards. 80 W power supply w/ fan. heavy duty construction. Will function perfectly with Apple-compatible disk drives and 3.3 DOS.
LIST \$795
Holiday Special \$595!!!



SPECIAL \$1.00 PACKAGES:

Buy a COLUMBIA VP portable at list and get a RITEMAN printer for only \$1

Buy an EAGLE II at list and get a GEMINI 10X printer for only \$1

IBM COMPATIBLE BOARDS

BUBBLE MEMORY CARD by Helix: A reliable, fast alternative to hard disk!!! Runs under MS/DOS 2.0. Immediate availability:

2 MB... \$999 4 MB... \$1499

This product truly opens a new era in computing: Bubble memory is not erased at power-down, no moving parts and therefore inherently much higher reliability than hard disk (especially for portables)—and price that is competitive with hard disks!

AST RESEARCH: Most advanced boards for the PC

PC-NET Starter Kit: 2 Adapter Boards, all needed cabling and software. LIST \$1490 \$ CALL

Additional Adapter Boards (1 needed per workstation) LIST \$695

Mainframe Adapter Board: To connect IBM-PC to System 34, 38 or any mainframe accepting 3270, 3780 interface. LIST \$895 \$ CALL

Direct Connect Modem: Auto-dial/receive, auto-BAUD, clock, 1S + 1P, Game port LIST \$695

MegaPlus: 64K-256K RAM, Superdrive Disk Emulator, Superspool, Clock, 1P + 2S, Game port. LIST \$395 \$ CALL

IO-Plus: 2S + 1P, Game port, clock LIST \$315

PASOCOM: Absolutely BEST BUY: 256K RAM, 1P + 1S, Game port, clock & calendar unbeatable value \$369

QUADRAM: All boards available \$ CALL
Quadlink \$ CALL

PRINTERS



Mannesmann-Tally MT-160L: No other printer can match all these features: serial AND parallel inputs standard. 160 cps standard, plus LETTER-QUALITY printing at 50 cps, dot graphics standard, frontpanel programming standard, heavy-duty construction. **TRACTOR INCLUDED** \$ CALL
MT-160L NEW up to 264 columns! \$ CALL

GEMINI 10X from Star-Micro: All the features of EPSON-FIT, plus backspace, continuous underline. LIST \$499 \$ CALL!!!

GEMINI-15: similar but 15" carriage. Even better buy. LIST \$649 ONLY \$ CALL!!!

Okidata Pacemaker 350 cps LIST \$2695 \$1999
Anadex WP-6000 LIST \$2699 \$1995
IDS Microprism \$ 519
Epson FX-80 \$ CALL Epson RX-80 \$ CALL
Okidata 92 \$ CALL

RITEMAN Dot-Matrix Printer: Small enough to fit in your briefcase (27x14"x10 1/4", 11 lb.), yet prints 80/132 col. AND full dot graphics (9x9 pinthead) at 120 CPS on standard. \$499 \$ CALL

Daisy-Wheel Printers:
DAISYWRITER 2000: 48K buffer \$1099
TRANSTAR 130, emulates Diabolo \$ 699
TRANSTAR 315 color printer \$ CALL
BROTHER HR-1 \$ CALL
BROTHER HR-15, best buy LIST 599 \$ CALL
QJME Sprint II \$ CALL
DIABLO 620 \$ 999
JUKE 6100 low cost/high perf. LIST 699 \$ CALL
Silver-Read EXP 550 \$ 649
Smith Corona TPIH \$ CALL
Mannesmann-Tally Spirit LIST 399 \$ CALL

PLOTTERS:

Strobe Plotter \$ CALL
Mannesmann-Tally Pxy 3 LIST 795 \$ 679

OTHER COMPUTERS

NEC P-8800: High flexibility & performance: Z-80 CPU w/ optional 8086 CPU, ROM BASIC, choice of 5 1/4" Floppies, dedicated graphics RAM \$ CALL

Micro-Decision by Morrow Designs: Highly-rated, Z-80, 64K RAM, 2 Floppies, optional terminal, CP/M w/PILOT "shell," WordStar, SpellChecker, LogiCalc, BASIC-80, Basic, Personal Pearl & Quest Bookkeeping system (only w/MD-3). \$972

MD-2 single-sided Floppies, \$1245
MD-3 double-sided Floppies, Quest Bookkeeping \$545
Morrow Terminal or Liberty Terminal

Superbrain QD: List \$2895 \$2245

TeleVideo 803: All features of the well-known TeleVideo 802 (RS422 interface optional) + graphics + larger screen + free W/P & SpreadSheet = Unbeatable Buy! LIST \$2495 \$2099
TeleVideo 1603, 806, 816: Our prices are the lowest \$ CALL

BASIS-108 Z-80 & 6502 CPU, high-res. graphics, 64K RAM \$2099

EAGLE-II 64K RAM, superb display, dedicated word-processing keys, SpellBinder, UltraCalc, CBASIC, CP/M, e Floppies 780 KB. List \$1999 \$1645

Sanyo MBC-2000 8085 CPU, 2 Floppies 640KB LIST \$3495 \$ CALL

NorthStar Advantage 8-bit w/16-bit upgrade, extensive software. LIST \$2999 \$2499

PORTABLE COMPUTERS

PIED PIPER PORTABLE COMPUTER: First truly portable computer comes with a built-in quad-density Floppy (1 MB unformatted, 5 1/4"). 64K RAM, full-size keyboard, CP/M, PerfectWriter, PerfectSpeller, PerfectCalc and PerfectFiler. Serial and parallel output. No monitor, but can use external monitor connect to your own TV (RF modulator built-in) or use optional built-in modem (300 Baud auto-dial/answer). WEIGHS ONLY 12.5 lb, and small enough to carry daily from home to office (4"x20"x11"). LIST \$1296 \$989

TeleVideo

TeleTote 1: Portable computer with outstanding graphics, 8 bit 96-160K RAM, 2 Floppies 737 KB, Mouse port, CP/M, GSX graphics software, WordProcessor, SpreadSheet. LIST \$1499 \$ CALL Available NOW



TERMINALS:

Hazeltine ESPRIT II LIST 645 \$539
Hazeltine ESPRIT III LIST 895 \$619
QJME QVT-108 LIST 895 \$729
WYSE 100 LIST 995 \$ CALL

MONITORS:

USI green, 12" \$137
USI amber, 12" \$149
Taxan RGB-1 \$315
Taxan RGB-III hi-res. \$514
Zenith RGB hi-res. \$524
Princeton PGS hi-res. \$495
NEC 1203 RGB \$610

MODEMS:

Hayes Smartmodem 1200 \$484
SmartCom II \$ 79
Hayes 1200 B (f/IBM-PC) \$449
US Robotics (similar to Hayes, but lower priced) \$399
Autolink 1200

16-BIT COMPUTERS

COLUMBIA 1600 A BEST BUY:

Fully compatible with IBM-PC, accepts all IBM boards, reads all IBM software, 128K, 8 expansion slots, 2 Floppies or 1 Floppy + 10 MB hard disk, 8087 socket, Columbia supports up to 4 users under MP/M-86 or Multi-user MS-DOS.

Free Software: MS-DOS, CP/M-86, BASICA, MS-BASIC, PerfectWriter, PerfectSpeller, PerfectFiler, PerfectCalc, Fast Graphs, Home Acct. Plus, Macro-Assembler, Asynch, Communications, Columbia Tutor, Diagnostics, Space Commanders. **Nationwide service** by Bell & Howell.

Columbia 1600-1 system w/amber monitor LIST \$3495
Columbia 1600-4 10 MB Winchester LIST \$5095 \$ CALL
MP/M-86 Multi-user operating system LIST \$695 \$ CALL



COLUMBIA VP PORTABLE

LIST \$2995
\$ CALL



CORONA-PC: Runs most IBM software. Exceptionally high-res. display & graphics. MS-DOS, CP/M-86, GW-BASIC, GSX graphics software, W/P & Spread Sheet.

Corona-PC LIST \$2995 \$ CALL
Corona Portable PC LIST \$2795 \$ CALL

TeleVideo 1602G: 160K RAM, NEC 7220 graphics co-processor, 8087 socket, detachable keyboard, GSX Graphics software. LIST \$4495 \$ CALL

SANYO MBC-550

The first IBM-compatible computer under \$1,000!

Standard features: 8088 CPU, 128K RAM, 1 Floppy 160 KB, color graphics controller, printer port. **Software Included:** BASIC, DOS for compatibility with most IBM software, 8087 Arithmetic start in September. This computer is already a hot seller and our first shipment has been completely sold out! \$ CALL



NEC-APC: Extremely sophisticated graphics & color display, 8086 CPU, 128K RAM, 1 or 2 8" Floppies, Hard Disk option.

SPECIAL OFFER: CP/M-86, WordStar, SpellStar, MailMerge, SuperCalc, dBASE-II, Millionaire game included FREE.

H02 Monochrome: LIST \$3448 \$ CALL
H03 Color: LIST \$4198 \$ CALL



Zenith Z 100 w/hard disk \$ CALL

DEC Rainbow-100:

Now w/MS-DOS, runs most IBM software \$2935



EAGLE-PC: Many deluxe features (105 key keyboard), 8086 CPU for faster processing.
EAGLE-PC-E: 1 Floppy, LIST \$1995 \$1555
EAGLE-PC-2: 2 Floppies, monitor, software. LIST \$3495 \$ CALL
EAGLE-PC-XL: 1 Floppy, 10 MB Hard Disk. LIST \$4495 \$ CALL

NEW COD 15-Day Exchange Privilege
Mo-Fri 9:00 AM-5:30 PM PST Sat 12:00 Noon-5:00 PM PST

(800) 845-5555 CA AK HI call (714) 832-3443

AMERICAN EXPRESS VISA MASTERCARD
P.O. Box 3791 Riverside CA 92519

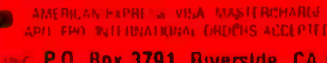

TERMS: All orders are shipped FOB destination. Prepaid orders only. Payment in full is required at the time of purchase. Delivery is subject to product availability. All prices are in U.S. dollars and include shipping and handling charges. Taxes and duties are extra. Returns are accepted within 30 days of purchase. Refunds are given in the form of store credit. No cash refunds. All prices are subject to change without notice. © 1983 American Radio History, Inc.

APPLE is trademark of Apple Computer Inc. IBM is trademark of International Business Machines Corp.

Photographic Animation of Microcomputer Graphics

By compensating for a computer's slow rate of display generation, a movie camera can produce pleasing animated graphics

by Peter Cann

A computer's ability to generate pictorial displays opens the door to many exciting applications, but most computers can't achieve the animation quality of commercial movies or TV. Interfacing a movie camera to a computer, however, can overcome this drawback.

The inability of most computers to achieve TV-quality animation stems from their video-display generation rates. These low rates prevent a computer from generating the successive, slightly different images quickly enough to create the illusion of continuous motion as perceived by the human eye. For example, simulating

a piece of TV footage in real time (requiring 60 frames per second) is a challenge beyond the capability of any ordinary computer.

The phrase "in real time" in the preceding paragraph is significant. Without it, the sentence it qualifies would be false. For in terms of resolution, many computers can generate images showing much more detail than can broadcast TV, even though these computers might not be able to flash a new frame on the screen every 1/24 or 1/60 second, as can movie and TV equipment, respectively.

One way to solve the speed problem is to photographically animate a

computer's visual output. This technique allows a computer to take as much time as it needs to generate each frame. When the computer completes one frame, a movie camera, whose shutter is triggered electronically by the computer, transfers that image to a single frame of film and then advances the film by one frame. The computer then begins to draw the next frame. When it finishes, the camera records that frame and again advances its film one frame. When the entire presentation has been captured one frame at a time in this manner, the film is developed and shown at sufficient speeds to be of interest to people.

Effective use of this technique requires an understanding of the factors that affect still photography of video images, such as exposure timing, ambient light, and the alignment of the camera with the screen. For all but the briefest presentations, it is almost imperative to have the camera controlled by the computer (see figure 1).

This article offers various tips for those interested in still or stop-action photography of video displays. Along with explanations and suggestions of a general nature, I will present examples, including programs and camera-control interfaces, for the TI-99/4 and Apple II computers.

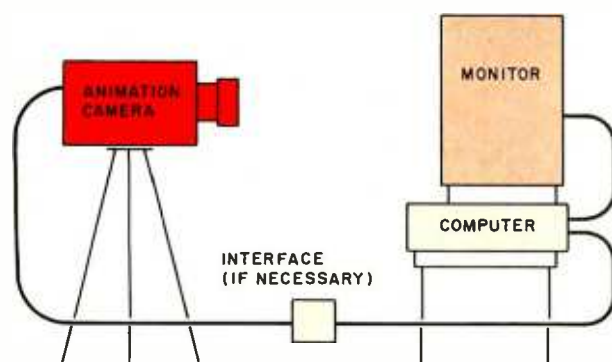

Figure 1: A system block diagram. In this configuration, the animation camera is focused on the monitor, which in turn receives and displays the computer's video output. The camera's trigger circuit is interfaced to the computer.

(1a)



(1b)



Photo 1: Video display and cabbage. Photo 1a shows that bright external light and a brief (1/125 second) exposure are good for the cabbage but bad for the video display. Photo 1b, in contrast, shows that no external light and a long (1/2 second) exposure are great for video display—but where's the cabbage?

Shooting Video

Photographing a TV picture is not the same as photographing, say, a cabbage (see photo 1). The TV image is created by an electron beam of varying intensity that scans across the phosphor-coated screen at high speed. The phosphor glows where the beam hits it, with a brightness related to the beam's intensity. The beam scans one horizontal line every 60 microseconds or so, generating a complete frame every 1/60 second.

A photograph of a TV screen exposed for less than 1/60 second comes out with parts of the picture much darker than the rest (see photo 2a). These parts may not be completely black because the phosphor continues to glow dimly for a short time after the electron beam stops striking it. An exposure slightly

longer than 1/60 second results in parts of the picture being somewhat brighter than the rest (see photo 2b); the bright parts were scanned twice during the exposure while the rest of the picture was scanned only once.

Any exposure that is an exact multiple of 1/60 second should provide an excellent picture, but camera timing accuracy must be better than ± 1 percent for the lower multiples—for example, 2/60 or 3/60 second. The few cameras whose timing accuracies I have observed have not met this requirement (see photo 2c).

One good way to photograph an unchanging TV image is with a very long exposure. Because each dot is generally scanned either n or $n+1$ times during an exposure, you can simply make n great enough so that the difference between the two pos-

sibilities is insignificant. I recommend something like 1/2 second, which entails about 30 video scans. Anything shorter than 1/15 second results in noticeable image degradation due to timing effects.

These timing problems are much less serious if a monitor with a high-persistence phosphor is used. The persistence of a phosphor is a measure of how long a piece of it glows after being momentarily excited by an electron beam. The phosphor used in most green-screen monitors has much higher persistence than that found on TV.

Another threat to picture quality is stray light. Unlike the cabbage, which we see by means of the light it reflects, the TV picture is luminous. It makes its own light, and any light striking it from outside only washes

(2a)



(2b)



(2c)



Photo 2: Video-display photographs illustrating the effects of camera timing. The 1/125-second exposure used to take photo 2a was too brief to record a whole frame. The shutter opened while the middle of the screen was being scanned and closed before the electron beam returned to the top of the screen. Note that the phosphor near the top was still glowing during the exposure even though the electron beam had passed on. In taking photo 2b, the timing control was set between 1/60 and 1/30 second; thus, some screen areas were scanned twice while the shutter was open, some only once. To take photo 2c, the camera was set for a 1/30-second exposure. Every part of the screen should have been scanned exactly twice while the shutter was open. Unfortunately, the camera's timing mechanism is not sufficiently precise for this purpose.



Photo 3: Video display with candle, resulting in two sharp reflections of the candle's flame: one from the front surface of the glass screen and another from the back surface. Light from the flame also scatters back from the phosphor in all directions.

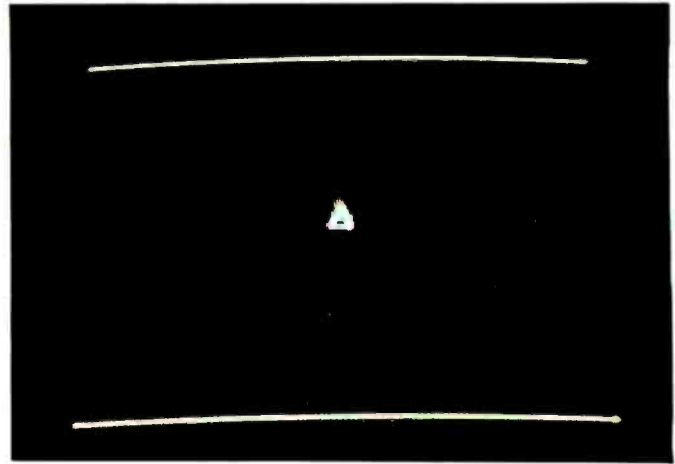

Photo 4: This photo indicates parallax effects. Although the two lines shown here are of equal length on the computer monitor, the lower one looks longer because the camera was positioned below the monitor, looking up at an angle of about 45 degrees.

out the picture. This problem manifests itself in two modes: some light may bounce from the surface of the glass as if from a mirror, while other light may scatter back from the light-gray phosphor inside (see photo 3). Cue lights on the front of the camera should not be overlooked as a source of such interference. For example, the jumbo red LED (light-emitting diode) on the front of our animation camera at Logo Computer Systems Inc. (LCSI) bounced light off the surface of the screen and into the lens, showing up on the film. To prevent image degradation due to this light, we usually covered the LED with tape.

One last point: if the camera is not aligned squarely with the screen, parallax distortion occurs. For example, if two parallel lines of equal

length are displayed on the screen, and the part of the screen containing one line is closer to the camera than the part containing the other, the closer line will appear longer on the film (see photo 4).

The Animation Camera

At LCSI we used a Canon 1014 XL-S camera for animation. This Super-8 camera with single-frame capability and electronic remote control (see photo 5) offers three film speeds: 9, 18, and 24 frames per second, as set by the film-speed knob. In run mode these film speeds result in approximate exposure times of 1/15, 1/30, and 1/60 second, respectively. The 1/15-second exposure works pretty well for shooting video images.

With the camera in single-frame

mode, the film-speed knob continues to control exposure time. Unfortunately, the 9-frames-per-second position now gives a 1/30-second exposure. This setting produces an unsatisfactory picture with flickering diagonal stripes resulting from interaction of the camera's rotating slotted-disk shutter with the video scan.

While playing with the camera, we discovered that it would shoot a single frame at 1/15 second if we put it in the 9-frames-per-second run mode and closed the camera's trigger circuit for 1/3 second. (It seems likely that many cameras without a single-frame mode could be convinced to shoot single frames by using this method. Even the old windup movie cameras could prob-



Photo 5: Two views of the Canon 1014 XL-S animation camera.

Looking Good!



Composite Color Attractively Priced

- **Fine Resolution**—350 x 350 lines with 400 at center.
- **Full Compatibility with IBM PC**—as well as Apple II, Apple III, and many other popular personal computers.
- **Proven BMC Quality, Performance and Reliability.**

Contact your local dealer or call BMC direct for the dealer nearest you.

IBM® is a registered trademark of International Business Machines; Apple™ is a trademark of Apple Computer, Inc.



Setting the standard in price and performance.

LOS ANGELES

16830 South Avalon Blvd.
Carson, CA 90746
Telex: 664258 BMC GDNA
Phone: 213-515-6005

NEW YORK

450 Barend Avenue
Carlstadt, NJ 07072
Phone: 201-939-7079/7061

Dealer Inquiries circle #67. End users circle #68.

FACIT 4560

To put your micro computer on letter quality terms

Facit 4560 Letter Quality Printer is specifically designed for easy integration into your micro computer system.

And especially into applications where print quality, cost and ease of operation are important considerations.

The print wheel library features a variety of national versions and type-styles. The easy drop-in print wheels print fully formed characters. Bold face and shadow characters as well as automatic underlining add further printout versatility.

Pitch 10, 12, 15 and proportional corresponding to the inserted print wheel are controlled from the front panel or via the interface. All word processing commands are industry standard.

Friction feed, landscape and portrait paper handling, optional forms tractor and two-bin cut-sheet feeder completes your low noise (<60 dB) 22 CPS Letter Quality printer.

The Facit 4560.



FACIT
DATA
PRODUCTS

Circle 183 on inquiry card.

235 Main Dunstable Road
P.O. Box 828 Nashua, N.H. 03061
Phone: (603) 883-4157.

Europe: S-105 45 Stockholm, Sweden.
Phone: (8) 738 60 00.

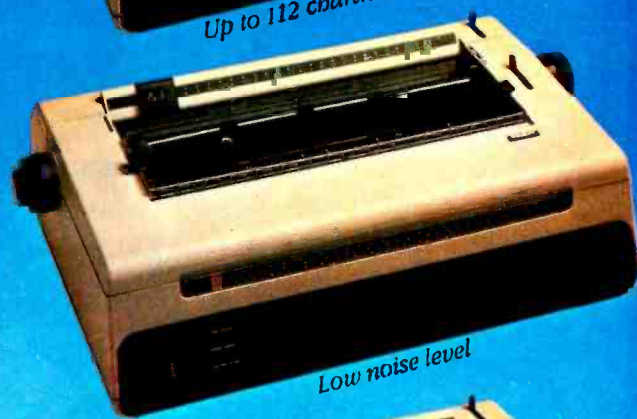

GET FULL VALUE FROM YOUR VICTOR 9000™

with the UCSD p-SYSTEM™ IV.1

Get the most from your VICTOR 9000 as well as from your software development efforts. The power and portability of the UCSD p-System is available for the VICTOR 9000 from TDI.

The Standard Development System Includes:

- Full Screen Editor, Filer, Assembler and other Utilities
- The UCSD Pascal Compiler
- Native Code Generator
- Ram Disk Support Above 128K
- Turtlegraphics - full use of VICTOR screen (800 x 400)
- Complete documentation

Options:

- Fortran 77 and Basic compilers
- Hard disk support



TDI SYSTEMS, INC
820 HUNGERFORD DR.
ROCKVILLE, MD 20850
(301) 340-8700

TDI LIMITED
29 ALMA VALE RD.
BRISTOL, U.K. BS8 2HL
0272 742 796

VICTOR 9000 is a trademark of VICTOR TECHNOLOGIES, INC.
UCSD p-SYSTEM and UCSD PASCAL are trademarks of the Regents of the University of California

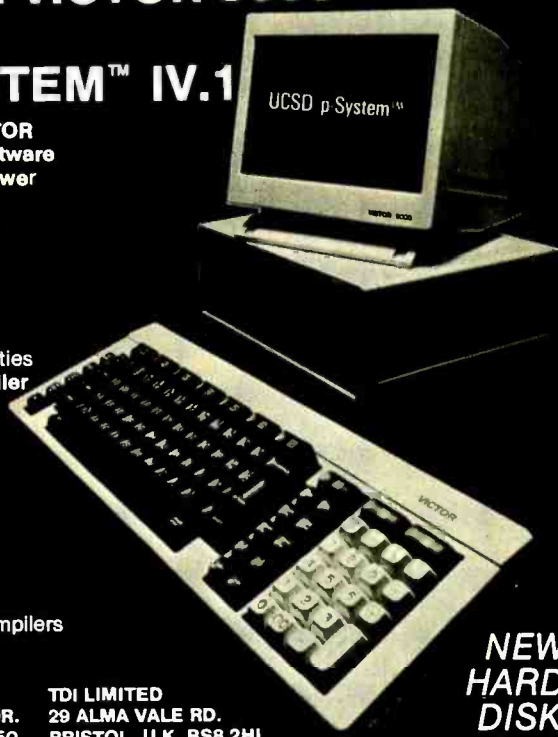

**NEW
HARD
DISK
SUPPORT**

then AC-coupled to the inverting input of the LM741C op amp through C2. This input is biased at +2.5 V by the voltage divider consisting of R2 and R3. The noninverting input of the op amp is tied to a voltage in the range of +2.5 to +3.6 V by the adjustable voltage divider consisting of R4, R5, and R6. The exact voltage is selected by experiment.

The output of the op amp is filtered by the R7-C3 combination. Diode D1 provides the desired fast-discharge, slow-charge action. Push button PB1, when pressed, holds C3 in the discharged state, duplicating the effect of the audio-beep signal. The voltage across C3 is interpreted by one of the twin 555-type timers in the LM556 chip. This half of the chip is configured as an inverter with hysteresis. Trip points at the input are 1/3 and 2/3 of the supply voltage. Including R7, C3, and D1, this circuit can be called a retriggerable one-shot.

The retriggerable one-shot output (LM556 pin 5) is made available to SW2 (mode select) and is coupled to the output-pulse-generator trigger input (LM556 pin 8) through the C4-R8 high-pass filter. Diode D2 protects this input from the +18-V spike created by the rising edge of the one-shot's output. The time constant for the output-pulse generator equals (R9+R10)C5, R10 added to avoid the possibility of a short circuit at low settings of R9.

SW2 connects the reed-relay coil to LM556 pin 5 (direct mode), nothing (safe mode), or LM556 pin 9 (pulse mode). Freewheeling diode D3 kills spikes created when the reed-relay coil is deenergized, and ballast resistor R11 reduces the load on the pulse-generator output (LM556 pin 9) sufficiently to ensure proper operation when SW2 is in pulse mode. (Adding R11 shouldn't be necessary; a healthy LM556 chip should be able to function while supplying up to 200 milliamperes to the relay. The interface that I built, however, couldn't end the output pulse until I installed the resistor. Other solutions might involve more careful layout or increased use of filter capacitors on the power lines.)

Power from a 9-V battery is con-

Put labels on your list.

Next time you shop for computer supplies, pick up a pack of Avery's new self-adhesive labels. By putting all your address lists on labels, you get more done in less time. Name badge labels, shipping labels, piggybacks and new clear labels are also available.

The labels are designed especially for micro computers. And they're packaged to fit neatly behind your printer. Look for them wherever you buy computer supplies.



Avery Label

An Avery International Company

Business Systems Division

Circle 50 for dealer inquiries.
Circle 51 for end-user inquiries.

LET THE "ANGEL"™ DO THE WAITING

Two RS-232C Connectors for serial input and output

6 Leds to indicate power, transmission and reception status, buffer activities, page number, etc.

SKIP and REPRINT provide independent page controls to reprint portions of documentation.

40 Pin Expansion Bus available for future expansion

COPY provides convenient one key operation for single copy or multi-copy of text

3 externally accessible Dip Switches for baudrate, device type, and parallel and serial selections. Selections can be made without losing buffer



Function keys extend the useful commands to more than 10, including: hex-dump, memory test, remote loading, etc.

8 easy-to-operate membrane key switches.

Independent PAUSE and HOLD controls to suspend transmission and reception.

Two 20 Pin Edge Connectors for parallel input and output

Connect an "ANGEL" between your computer and your printer, and let the "ANGEL" do the waiting

Your valuable computer spends 95% of its time waiting for the printer to catch up...and while the computer waits, the payroll continues.

The computer sends data to the "ANGEL" at speeds up to 19.2K baud. The "ANGEL" stores data and sends it to the printer at a speed the printer can handle, and your computer is free to continue working without interruption.

A USER WRITES:

"I tried the "ANGEL" with my Altos system connected to an Epson MX-100, both set at 9600 baud. Without the "ANGEL" it takes 30 minutes to print 210 doctors' requisition forms. With the "ANGEL" installed, my computer is free after 90 seconds."

With "ANGEL'S" self diagnostics and memory test, the entire system thoroughly checks itself every time you power up.

PAGE REPRINT is another unique feature. EXAMPLE: You are printing a 32 page report, and the paper jams at page 11. Reset the printer to the top of the form, press PAGE REPRINT, and resume printing at the top of page 11. Want to restart two pages back? Press PAGE REPRINT twice, and you resume at page 10.

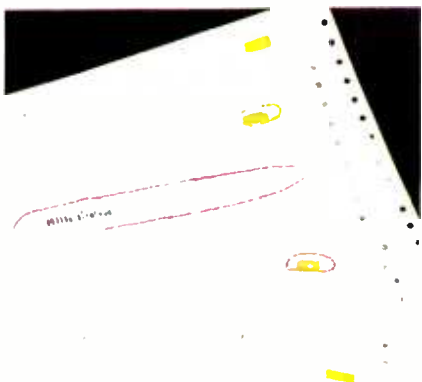

PAGE REPRINT

...And think of these other possibilities: HEX DUMP. Display or printout every bit of data your computer sends out to the printer in an easy-to-read Hexidecimal and ASCII format. A must for your programmer. Pause and Hold for real time programs. Page skip for selective printing. What a waste to print the entire documentation if you only need part of it.

Simple external switch settings, let the "ANGEL" accept either RS-232 serial or Centronics parallel data and can output either/or in any combination, (S,S,S-P,P-S,P-P). The "ANGEL" is compatible with almost all Micro-Computers, and can be installed by anyone in minutes. Switches are clearly marked for ease of operation, and a concise, USER FRIENDLY operator reference card is included with each unit.

The "ANGEL" has a full one year limited warranty.

THE "ANGEL" WILL NEVER KEEP YOU WAITING!



HEX DUMP

"ANGEL" is compatible with almost all Micro-Computers, including IBM, Apple, TRS-80, Vector Graphic, NorthStar, Altos, Xerox, Heath, Zenith, NEC, DEC, etc., with RS-232 serial, Hardware Handshaking, or Centronics compatible parallel interface. The manufacturer reserves the right to change the product specification.

ANGEL, The Intelligent Buffer, features:

- 64K Byte Memory Size
- Four Interface Modes in one unit:
 - Serial to Serial
 - Parallel to Parallel
 - Serial to Parallel
 - Parallel to Serial
- Serial Baudrate from 110 to 19.2K Baud
- Single, Multiple and Continuous Copy
- Clear/Reset
- Pause/Hold
- Page Skip
- Page Re-print
- Page-Pause
- Hex-Dump
- Self-Diagnostics
- Space Compression to extend the effective buffer size to more than 128K
- Price - \$295.00

TO ORDER:

CALL TOLL FREE 1-800-323-3304
OR SEND CHECK OR MONEY
ORDER TO LIGO RESEARCH

Please rush me () "ANGEL(S)" @ \$295.00 each

Sub total _____
ILLINOIS ONLY Add 6% U.S. sales tax _____
Delivery charge \$4.00 _____

TOTAL

Charge my () VISA () MASTERCARD
MY ACCT. # IS _____
EXPIRATION DATE _____



Photo 6: Filming under control of TI's Logo language.

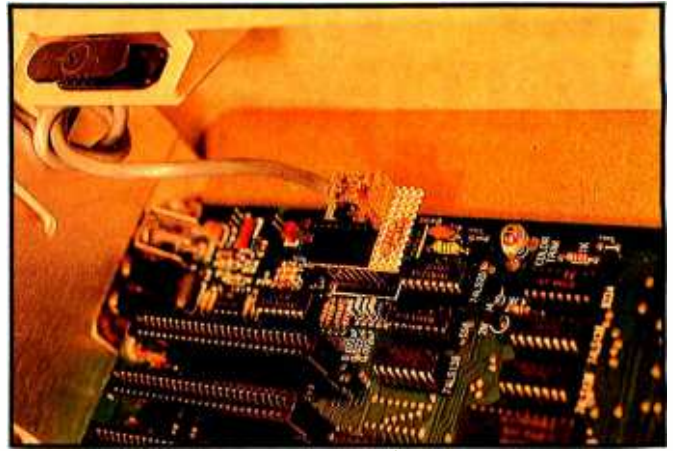

Photo 7: For a few dollars, this interface lets the Apple computer control an isolated set of contacts, which can control cameras, cassette decks, model trains, and other items. Game paddles can be plugged in on top.

trolled by SW1 and filtered by C6. C7 reduces harmful arcing of the reed-relay contacts. Video ground is used as a reference for interpreting the voltage on the single audio conductor supplied by the 99/4.

In use the camera is focused on the monitor screen and connected to the interface (see photo 6). The interface accepts the 99/4's audio and video plugs and provides a video plug to the monitor. The video plug is involved because the 99/4 has only one wire going to the audio plug; the interface, like the monitor, uses video ground as a reference for interpreting the audio signal.

I have also made a camera-control interface for the Apple that is much less complex than that for the 99/4. This relative simplicity is possible because the Apple provides latched logic outputs at its game I/O (input/output) socket along with power for user circuits. These outputs are controlled by referencing certain physical-logic memory addresses. The various Logo implementations for the Apple support this output control with `.DEPOSIT <address> <value>` and `.EXAMINE <address>` commands. They also provide a means of forcing a garbage collection, which prevents arbitrary garbage collections

from popping up for a little while, allowing generation of an accurate delay with a software loop.

The Apple interface consists of a relay driven by a transistor that is in turn driven by the Apple's Annunciator 0 (ANN0) output. The circuit is constructed on a vector board with a 16-pin wire-wrapping socket used as a plug to mate with the Apple's game I/O socket (see photo 7). Using the wire-wrapping socket is an easy way to allow things to be plugged in on top of the interface. If you feel uncomfortable about forcing the wire-wrapping pins into the Apple's socket, you can use a 16-pin header. This interface can be used without modification to control a cassette-deck motor.

The device to be controlled is connected to the normally open contacts of the relay (see figure 4). When ANN0 (pin 15) goes high, the resistor network pulls up the base of the transistor, saturating the transistor and energizing the relay coil. The resistor network limits the current in the base circuit when ANN0 is high and divides the voltage from ANN0 by a factor sufficient to ensure that, when ANN0 is low, the voltage on the base is comfortably below the turn-on threshold of the transistor. Referencing physical address 49241 turns the relay on, and referencing 49240 turns it off. Note the diode across the relay coil that allows for the orderly disposal of energy stored in the coil's magnetic field. Without the diode, a

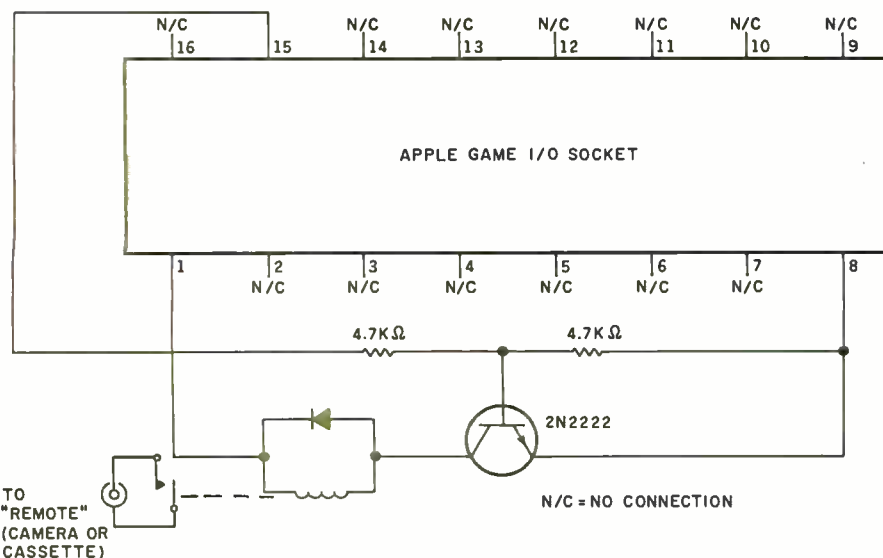

Figure 4: Apple-interface schematic diagram. The Annunciator 0 output of the Apple is amplified by the transistor and used to control the relay. The resistors protect the Apple and the transistor and ensure that the transistor turns off when it should. The diode allows the relay's coil current to decay gradually when the transistor turns off.



3M introduces the Purrrrrrrsonal Printers.



Quiet, high-quality printers at prices that won't scratch holes in your pocketbook.

\$299, manufacturer's suggested retail price, for a printer that puts 80 columns of full-size text, 136 columns of compressed print, and computer-generated graphics on crisp white paper. Or \$249 for the 40/80-column model.

Price is about the only way that our new 3M Silent PC Printers draw attention to themselves. At home or in the office, they're virtually inaudible since their non-impact electronic printing elements skim across the paper with none of the monkeylike chatter that you hear from ordinary matrix printers. Result: Less distraction for you, and less disturbance to others.

Our Silent PC Printers differ from most other sensibly-priced printers in another way, too. They print sharp, black characters from one end of the paper roll to the other, since there's no ribbon to wear out.

Maintenance is kept to a minimum since 3M Silent PC Printers have only two moving parts: the pinless printhead and the DC stepper-motor paper drive. They come with a one-year warranty (90 days on Printhead), and they're made in the U.S.A. by 3M, a company whose name is synonymous with quality.

Either serial or parallel interfaces are available. For literature, and for the name



40/80-column Silent PC Printer

of a dealer who can give you a demonstration, call **800-538-8157 Ext. 928** toll-free. (In California, call **800-672-3470 Ext. 928.**) In Canada, call **1-800-268-9055** and ask for operator #11. Or, if the cat's got your tongue, mail the coupon instead.

Mail to: **BYT1083**
 3M Business Communication
 Products Division
 Attn.: G. Collins
 3M Center—Building 216-2N
 St. Paul, MN 55144

- Please send literature on the new 3M Silent PC Printers and tell me where I can buy them.
 I'd like a demonstration soon.

Name _____

Title _____

Phone (____) _____

Company _____

Address _____

City _____

State _____ Zip _____

3M Business Communication Products Division

3M hears you ...



Circle 3 on inquiry card.

**Man and
machine...
the new
partnership.**

**Industrial
automation
comes alive at
AM84**

**TEXTILE HALL
CONVENTION CENTER
GREENVILLE,
SOUTH CAROLINA
MARCH 19-22, 1984**

Don't miss the event of the 80's as the Sun Belt explodes with the first automated manufacturing exhibition and conference.

Planned to bring the latest state-of-the-art hi-tech manufacturing and processing into the heart of the rapidly expanding industrial South, AM84 offers a full 4 day conference and exhibition.

The conference will have speakers of international stature. Both events will cover all areas of automated manufacturing and technologies. This will include robotics, metalworking, materials handling, CAD/CAM, process control instrumentation, CNC, micro-processing, flexible manufacturing systems and other related fields.

Call today for complete details on AM84.

Conference:
803/242-3170, Ext. 260

Exhibition:
803/233-2562

P.O. Box 5823
Greenville, S.C. 29606

AM84 Conference/Exhibition is co-sponsored by the Technical Education System of South Carolina and Textile Hall Corporation.

voltage many times greater than the supply voltage could appear across the transistor when the transistor tries to interrupt the current in the relay coil.

On machines already equipped with a software-controllable cassette-motor relay, the Remote cord

can be plugged directly into the 1014 XL-S camera. Such a direct connection should also work with machines that use a transistor to control the cassette motor if the wiring is such that the camera's control-circuit current can flow through the transistor in the appropriate direction.

Listing 1: TI Logo procedures used to generate an animated film, frames of which appear in photo 8.

```
TO ACTION
TELL TURTLE
CLEARSCREEN
HIDETURTLE
COLORBACKGROUND 1
SETCOLOR 15
SX - 80
SY 30
SETHEADING 90
L
O
G
O
NOPENCIL
REPEAT 24 [SHOOT]
SIGNAL
END
```

```
TO L
PENDOWN
RIGHT 90
DRAWFORWARD 24
LEFT 90
DRAWFORWARD 16
PENUP
LEFT 90
DRAWFORWARD 24
RIGHT 90
DRAWFORWARD 4
END
```

```
TO O
PENUP
DRAWFORWARD 12
PENDOWN
REPEAT 72 [DRAWFORWARD 1 RIGHT 5]
PENUP
DRAWFORWARD 16
END
```

```
TO G
PENUP
DRAWFORWARD 12
REPEAT 9 [DRAWFORWARD 1 RIGHT 5]
RIGHT 180
PENDOWN
REPEAT 63 [DRAWFORWARD 1 LEFT 5]
LEFT 90
DRAWFORWARD 12
PENUP
RIGHT 90
DRAWFORWARD 12
RIGHT 90
DRAWFORWARD 16
END
```

```
TO DRAWFORWARD :STEPS
IF :STEPS = 0 THEN STOP
FORWARD 1
BUILDPENCIL
SHOOT
DRAWFORWARD ( :STEPS - 1 )
END
```

```
TO BUILDPENCIL
MAKE "X ( XCOR - 7 )
MAKE "Y YCOR
TELL SPRITE 0
SETCOLOR 4
SY ( :Y + 4 )
SX :X
CARRY 0
TELL SPRITE 1
SETCOLOR 11
SY ( :Y + 12 )
SX :X
CARRY 1
TELL [2 3]
SETCOLOR 3
SY ( :Y + 28 )
SX :X
CARRY 2
TELL SPRITE 3
SY ( :Y + 44 )
TELL SPRITE 4
SETCOLOR 6
SY ( :Y + 60 )
SX :X
CARRY 3
TELL TURTLE
HIDETURTLE
END
```

```
TO SHOOT
BEEP
WAIT 10
NOBEEP
WAIT 60
END
```

```
TO NOPENCIL
TELL [0 1 2 3 4]
SETCOLOR 0
END
```

```
TO SIGNAL
COLORBACKGROUND 15
PRINT [ALL DONE.]
WAIT 60
COLORBACKGROUND 1
WAIT 30
SIGNAL
END
```

(8a)

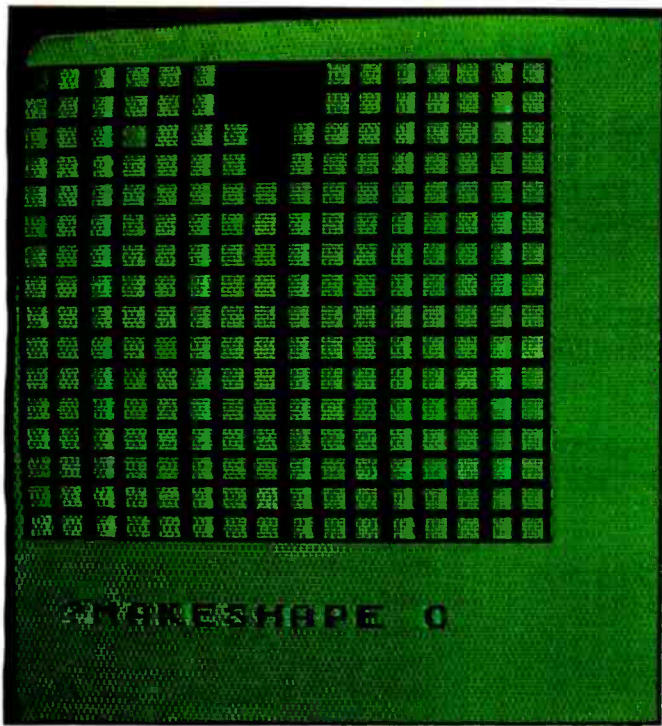

(8b)

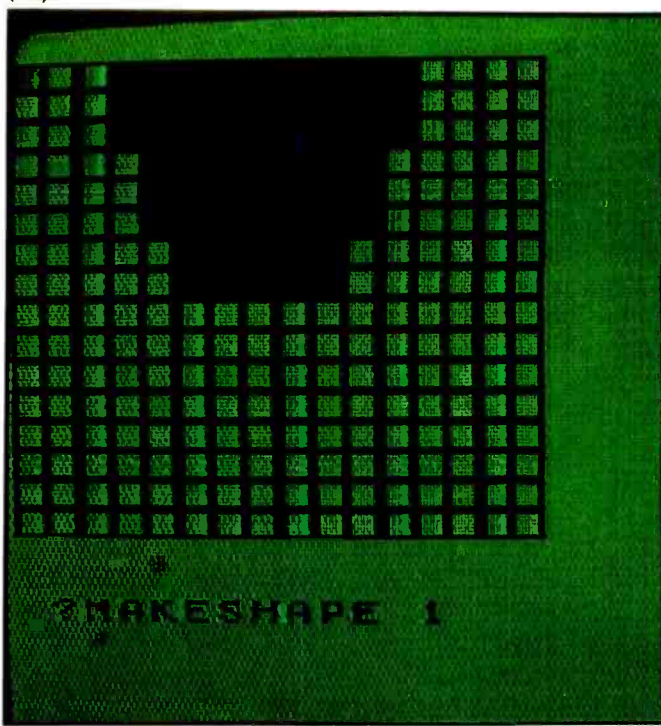

(8c)

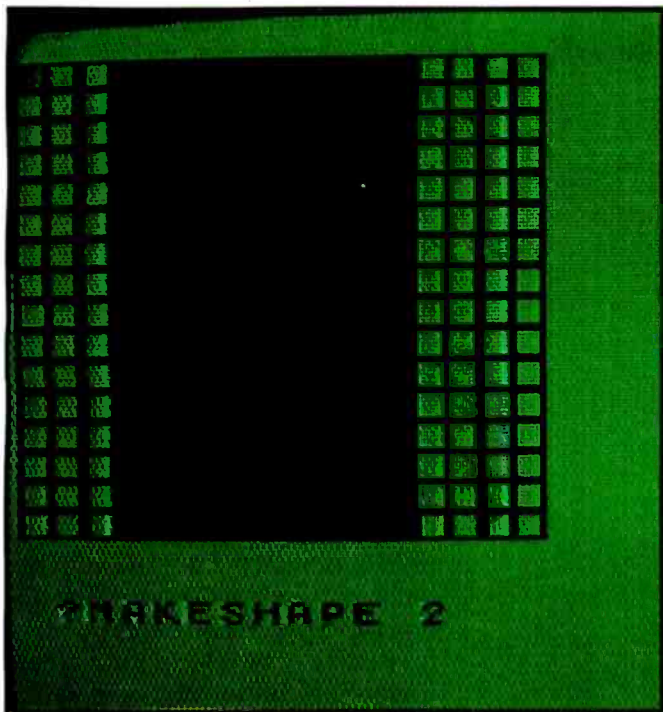

(8d)

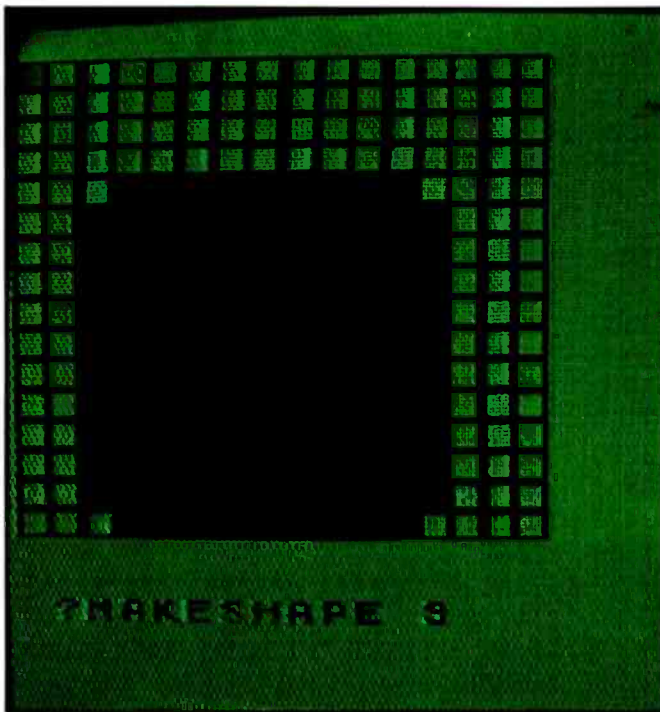

(8e)

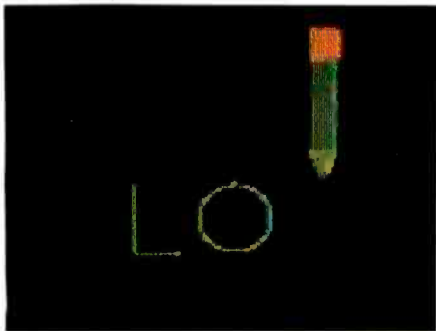

(8f)

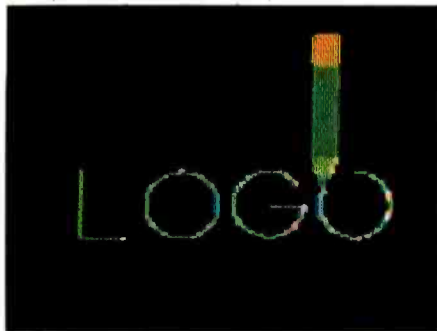

(8g)



Photo 8: TI Logo shape definitions (photos 8a through 8d) and the resulting action shots (photos 8e through 8g).

```

100 TEXT : HOME : VTAB 5
200 PRINT "THIS PROGRAM GENERATES AN ANIMATED FILM"
300 PRINT "OF A TIME-VARYING GRAPH OF VOLTAGE (Y)"
400 PRINT "VERSUS POSITION (X) VERSUS TIME (T) FOR"
500 PRINT "A RESONATING LENGTH OF PERFECT TRANS-"
600 PRINT "MISSION LINE WITH SHUNTED ENDS."
700 PRINT
800 PRINT "THE LINE IS ASSUMED TO BE RESONATING"
900 PRINT "AT ITS FIRST AND SECOND HARMONICS WITH"
1000 PRINT "EQUAL AMPLITUDES."
1100 PRINT
1200 PRINT "WHEN PROJECTED AT 24 FRAMES PER SECOND"
1300 PRINT "EACH CYCLE OF THE FIRST HARMONIC TAKES"
1400 PRINT "ABOUT ONE SECOND."
1500 PRINT : PRINT
1600 PRINT "PLEASE ENTER THE NUMBER OF SECONDS TO"
1700 PRINT "BE FILMED. RETURN TO BEGIN. --->";
1800 INPUT S
1825 PRINT
1850 PRINT "STANDING WAVE,"
1875 PRINT "FIRST AND SECOND HARMONICS."
1890 HCOLOR= 7
1900 FOR T = 0 TO (S * 6.28318) STEP .261799
2000 HGR
2100 FOR X = - 1 TO + 1 STEP .02
2200 Y1 = SIN (T) * COS (X * 1.57080)
2300 Y2 = SIN (T * 2) * COS ((X + .5) * 3.14159)
2400 Y = Y1 + Y2
2500 H PLOT (130 + (X * 120)),(90 + (Y * 40))
2600 NEXT X
2700 POKE 49241,0
2800 FOR D = 1 TO 300
2900 NEXT D
3000 POKE 49240,0
3100 FOR D = 1 TO 1000
3200 NEXT D
3300 NEXT T
3400 TEXT : HOME : VTAB 10
3500 FLASH
3600 PRINT "*****"
3700 INVERSE
3800 PRINT : PRINT "FILMING COMPLETED."
3900 NORMAL
4000 END

```



Photo 9: Two examples of the Applesoft transmission-line model in action.

Photographic Animation Examples

The set of TI Logo procedures shown in listing 1 and shape definitions shown in photo 8 cause the previously described TI hardware system to generate an animated film of a pencil writing the word "LOGO." Although this animation looks pretty good on the monitor, the film provides better animation quality. The procedures are given in the order that they are first called. ACTION is the top-level, script procedure.

The Applesoft program shown in listing 2 generates a time-varying graph (see photo 9). The graph represents relative voltage in terms of time and position along a resonating length of perfect transmission line with shunted ends. The line is assumed to be resonating electromagnetically at its first and second harmonics. The length of the line is equal to one-half the wavelength of the lower frequency and one wavelength of the higher. The amplitudes of the two frequencies are the same.

Conclusion

It is often useful to photograph a computer-generated video image. Exposure timing, ambient light, and the positions of the camera and monitor are critical to the success of such photography.

When a computer is able to generate a series of displays that would be interesting or useful if—and only if—display rates could be many times faster, photographic animation can be used to achieve the desired multiplication of speed. In almost all applications of this technique, it is extremely desirable to place the camera under the control of the program generating the display. ■

This project was carried out under the auspices of Logo Computer Systems Inc. (9960 Cote de Liesse, Lachine, Quebec H8T 1A1, Canada, (514) 631-7081).

Peter Cann, who is almost entirely self-educated in the computer field, has a near congenital fascination with machines. His first exposure was to an IBM 370 running FORTRAN. After a brief stay at MIT and a few years of freight handling, he wound up at Logo Computer Systems. He is now with Atari (5 Cambridge Ctr., Cambridge, MA 02142) maintaining a Unix VAX. Peter enjoys hacking anything that beeps, whirrs, or crunches.

True or False: You Can Now Run Apple Software in Your IBM[®] PC.

✓ True. Introducing Quadlink by Quadram. The revolutionary enhancement board that turns your IBM Personal Computer into an Apple compatible system.

Quadlink. Simply plug it inside your PC, press a few keys, and instantly run virtually any Apple software package available.

Quadlink greatly enhances your PC's capabilities.

✓ True. Quadlink gives you access to the largest software library ever written. Business, educational, and entertainment packages. Software for any professional or home use. This means your PC can now do more than ever before. In more ways than ever before.

AVAILABLE AT AUTHORIZED FULL-SERVICE QUADRAM DEALERS WORLDWIDE.

© Copyright 1983
Quadram Corporation
All rights reserved.

With Quadlink, there's no diskette reformatting needed.

✓ True again. With Quadlink you'll never have to worry about "compatibility." Just put your Apple diskette in the PC drive and watch it go. It's that easy. Like having an Apple computer inside your IBM.



QUADLINK™ BY QUADRAM™

And every Quadlink comes with that traditional Quadram Quality built right in.

✓ Absolutely true.

Quadlink is available only at authorized full-service Quadram dealers.

✓ True. So visit the Quadram dealer nearest you today and ask to see Quadlink in action. And while you're there ask about our full line of IBM PC enhancements. Including the popular six-function Quadboard™. You'll agree: when it comes to quality engineering and dependable performance, Quadram passes the test.



QUADRAM
CORPORATION
1983

4355 International Blvd., Houston, TX 77057
(713) 923-8886 TW/CR 706 4015 (C) 1983 QUADRAM CORP.

\$680.00
Suggested Retail

Apple and the Apple logo are registered trademarks of Apple Computer, Inc.

IBM and the IBM logo are registered trademarks of International Business Machines Corporation.

NEW MATRIX PRINTER OUT PERFORMS ITSELF 3 TO 1.

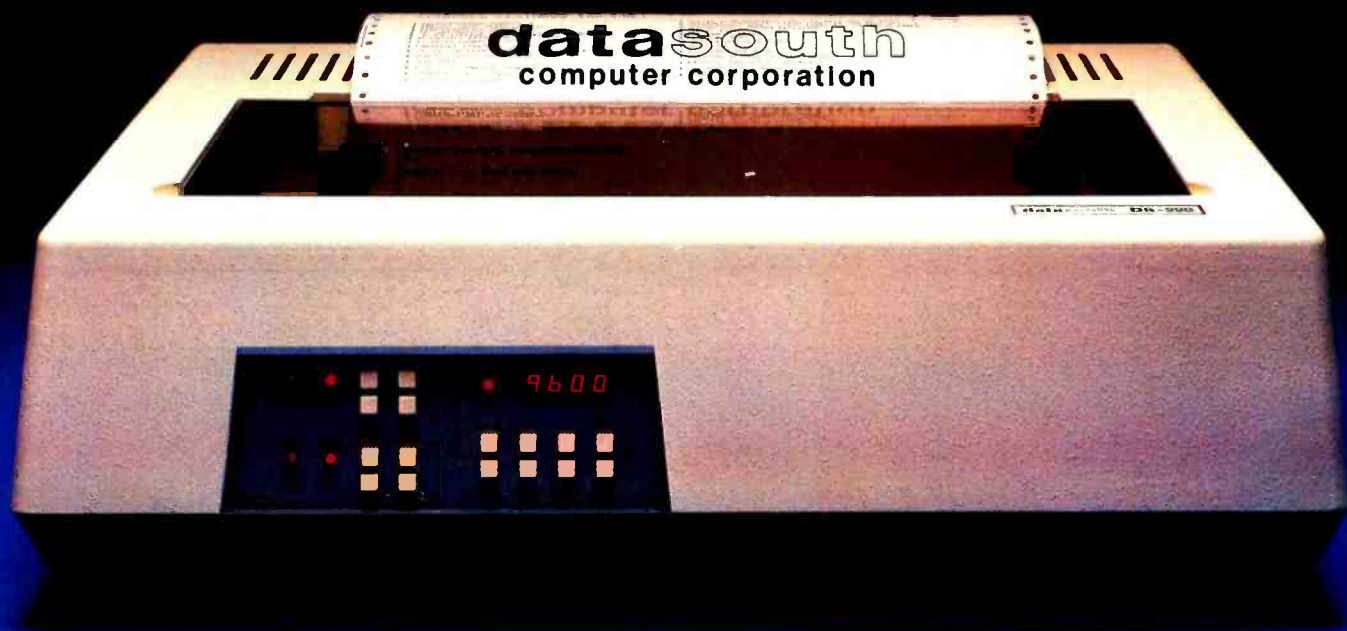

H I G H P E R F O R M A N C E

INTRODUCING THE NEW DS220 MULTI-MODE MATRIX PRINTER

In the beginning was the Datasouth DS180. A printer that *defined* high performance printing, with a balance of high technology design and mechanical simplicity. A high throughput printer that produced clean hardcopy under the most severe conditions.

Now there's the Datasouth DS220. A printer that raises those high performance standards and applies Datasouth technology to multiple printing tasks — all at one time.

The Datasouth DS220 redefines high performance for multimode printing the way the DS180 did for data quality printing.

For speed, the DS220 combines a 220 CPS print speed with servo-controlled logic seeking and high-speed tabbing over blank spaces. This allows the DS220 to zip instantly from one printable character to the next. In side-by-side tests of real-task performance — not just spec-sheet comparisons — the DS220 outperforms its rivals time after time.

For correspondence, the DS220 uses its 40 CPS bi-directional NLQ mode to form characters with the precision and clarity you would expect from a word processing printer.

And for graphics, the DS220 adds high performance artistry to popular microcomputer applications programs through high-resolution, dot-addressable output. Sharp new details emerge from business charts and graphs, and from engineering drawings.

The sum is even more than three printers in one. The DS220 offers a total of eleven different pitches and fonts along with seven international character sets. Plus non-volatile space for up to 64 do-it-yourself characters for downloading from the host computer.

And those are just the printing capabilities. In other respects, the DS220 outperforms not just itself but virtually every other printer on the market. Its front panel programming sets new standards in user friendly printer ergonomics. Its four digit LED display and push button panel allow programming of over fifty features, with a minimum of fuss and confusion. Those features include a variety of interface and communications selections that allow compatibility with a wide range of mini and microcomputers. And the DS220 handles six part forms with its adjustable tractor feed, as well as cut sheets and letterhead with its friction feed.

Best of all, the DS220 advances all the engineering, design and mechanical virtues established by its forerunner, the DS180. In the Datasouth tradition, the DS220 is made to run virtually nonstop in a wide variety of applications.

Test drive three high performance printers in one — the multimode DS220.

Call for details and the name of your nearest Datasouth sales/service distributor.

HIGH
PERFORMANCE

HIGH
PERFORMANCE

HIGH
PERFORMANCE

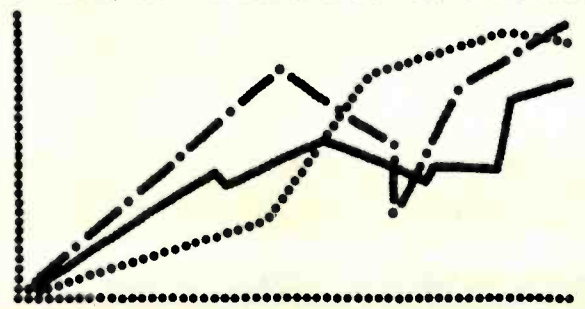

Simulated output shown. Call or write to Datasouth for samples of actual output.

datasouth

M A T R I X P R I N T E R S

Available nationwide through our network of sales/service distributors.
Datasouth Computer Corporation • Box 240947 • Charlotte, NC 28224
704/523-8500 • Telex 6843018 DASOU UW

Circle 141 on inquiry card

The Fourth National Computer Graphics Association Conference

*Graphics hardware is better, faster, and cheaper—but the software
still lags behind*

by Alexander Pournelle



Photo 1: A view of McCormick Place, where NCGA 1983 was held. (Photo by the author.)

The National Computer Graphics Association (NCGA) Conference is to computer graphics what the National Computer Conference (NCC) is to the entire computer industry. All the manufacturers go to the NCGA show to exhibit their latest in picture-making equipment. The conference is only about a quarter the size of the NCC, but that means there's a fighting chance one person can see the whole show. (Some of the companies represented at NCGA and SIG-GRAPH are listed in the text box at the end of this article.)

This summer's NCGA was held in Chicago's McCormick Place, the largest convention hall in the United States (see photo 1). I spent only two days at the show last year. I was at this year's for four solid days and still didn't see every booth and exhibit.

What can these newfangled machines do that Aunt Rhoda's Atari can't? Well, an Atari 800 can display only eight colors at a time on a field of 320 by 192 pixels (picture elements). The very best in computer graphics displays are 4096 by 4096 pixels and can display over 16 million colors. Top-of-the-line machinery can write at more than 10 million pixels per second, making images move incredibly fast. Only the most demanding applications can currently justify the high price (\$30,000 and up) that quality demands. Prices are falling, however. What was \$100,000 last year is now \$50,000.

The theme of 1982's NCGA conference was electronic drafting. This year, the focus moved to electronic graphs. Businessmen surpass engineers as the largest market segment. Businesses want "presentation graphics"—bar and line graphs, pie charts—and they're willing to pay a lot for them. The tone of this year's NCGA show was quite different from last year's. Electronic drafting and CAD/CAM (computer-aided design/computer-aided manufacture), although still very important, were second-place topics behind presentation graphics. Office automation (which overlaps the graphics industry) and imaging tied for third place. New companies making one or two graphics devices were the most

exciting part of the show, as always.

Robert Heinlein fans will be happy to know that Drafting Dan, from the book *Door into Summer*, is alive and well. Heinlein described Dan as a cross between a drafting table and a typewriter but didn't predict that plans would be laid out on a video display before pen ever touched paper. Tedious redrawing for engineering change orders can be all but eliminated with current CAD/CAM equipment.

Why are so many people interested in business graphics? It seems that designing a building is less important than presenting last year's sales figures in color. Management wants more productivity; color graphs can be drawn by computer much more

Drawing software at the conference ranged from poor to good.

quickly than by hand. The data is available before it's out of date. "Graphics at Work" was the show's official theme, but "Improving Business Communications" would be more accurate.

What are people in business doing with computer graphics? They're doing lines, bars, and pies: the three basic chart groups. I thought it was tragic to see so much equipment making such unimaginative pictures. I can only hope this will change. (For the author's report on a show emphasizing more imaginative graphics, see the text box at the end of this article.)

Last year I complained about the lack of games at the conference; it's a shame because games can demonstrate just what all this incredible machinery can do. This year I figured out why there are no games: credibility. The attitude I encountered was, "Can you imagine some corporate vice-president walking up to my booth and seeing Star Raiders? He'd never buy anything from me!"

Show Highlights and Lowlights

Interest in graphics is accelerating—the NCGA show grew about 20 per-

cent in floor space this year; already the number of companies signed up for 1984's show exceeds the number of this year's exhibitors. The highlight of 1983's show was galloping technology that's resulting in some outstanding equipment with astonishing potential. The show's lowlight was the drawing software, which translates the operator's (or artist's) commands into pictures. Drawing software at the conference ranged from poor to good; none of it was excellent.

The drawing software currently available enables you to draw lines, boxes, shades, circles, planes, and so on, but it lags behind the hardware by two years or so. Like most microcomputer software, it's not very self-explanatory or helpful. Slowly, microcomputer software has improved; there's a bunch that is really outstanding. I see that trend in drawing programs. A major cause of the lag is that companies formed to make new graphics products usually make hardware. If they write any software, it is often to test their new boards. As a result, the new guys on the block (and there are a lot of them) have incredibly powerful hardware but nothing to do with it. When the IBM Personal Computer was announced, little software was available. The situation improved when software writers saw the enormous potential market. The graphics market is perhaps less concentrated but almost as large as the PC software market.

New Product Profiles

Shows are horrible places to get any in-depth data on new products; nothing works perfectly. One company's main processor died the first afternoon of NCGA and wasn't revived until the next day. On the other hand, shows are great if you're worried about a company's product reliability. Electronics are notorious for breaking when moved.

Prices are plummeting. New, low-priced, medium-performance, medium-density boards were everywhere this year. Of course, low price to people in the graphics industry means \$4000 and up because they're used to paying \$40,000.

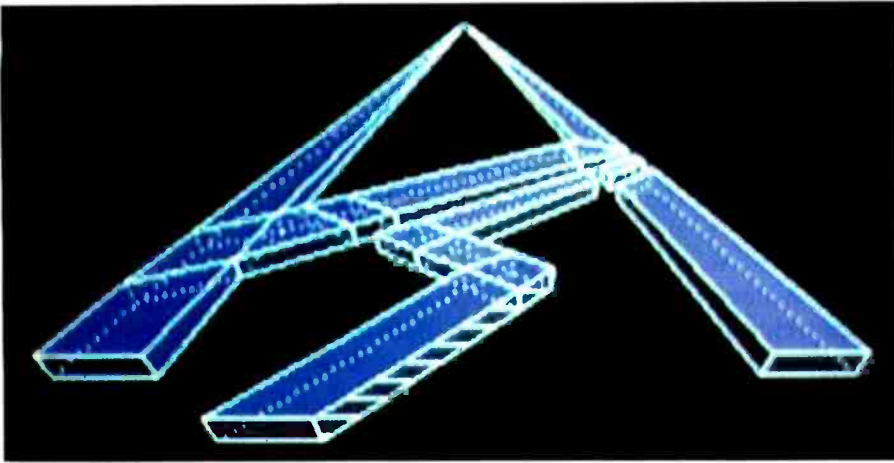

Photo 2: Color graphics from the Rampage board by Parallax Systems. The Rampage currently runs on LSI-11 machines, including the Heath H-11. (Photo by the author.)

A new product of interest is the Rampage, a low-priced, high-performance, medium-density board. The manufacturer, Parallax Systems Inc., started (of course) in a garage. Seven ex-employees of other graphics companies thought they could do better than their old bosses.

They may have been right. The Rampage awed other design engineers at the show. They would come over to the Parallax booth, quietly watch some demonstrations, then return later with more designers. What was so impressive was not the actual pictures being displayed but the speed with which they could be manipulated. Photo 2 shows the Parallax company logo in transparency; note how the lines behind it are dashed. The Rampage can switch quickly between this translucent mode and hidden-line mode (in which none of the back side shows). The board (about \$7000) is priced at less than a quarter of the nearest competition. Currently, the Rampage works only on the Digital Equipment Corp. (DEC) Q-bus, although Parallax plans to make different versions available quickly.

3M (you know, the makers of Scotch Tape) announced an interesting item: a fast overhead-transparency maker. Expect it at your graphics service bureau late this year or early next.

CP/M has long lacked any kind of graphics standard. Digital Research Inc. (DR) formulated what it calls GSX, or Graphics System Extension,

but almost no companies use it. The Visual 1050, a CP/M-based machine (see photo 3) that has true mono-

chrome dot graphics (640 by 300) built in at no extra cost, debuted at NCGA. The 1050 uses DR's GSX, can emulate a DEC VT-100, and comes with Wordstar, Multiplan, CBASIC, and CP/M 3.0; it should be available by the time you read this.

Speaking of CP/M, DR had better watch out for Unix. I was surprised last year to see so many CP/M-compatible machines but was more surprised this year to see a great switch-over to Unix and Unix-like operating systems. Graphics depend partially on operating systems for portability, and CP/M is still not set up properly for graphics.

As IBM PC look-alikes proliferate in the micro world, so do DEC VT-100 and Tektronix Inc. 4014 look-alikes in the graphics world. There are many

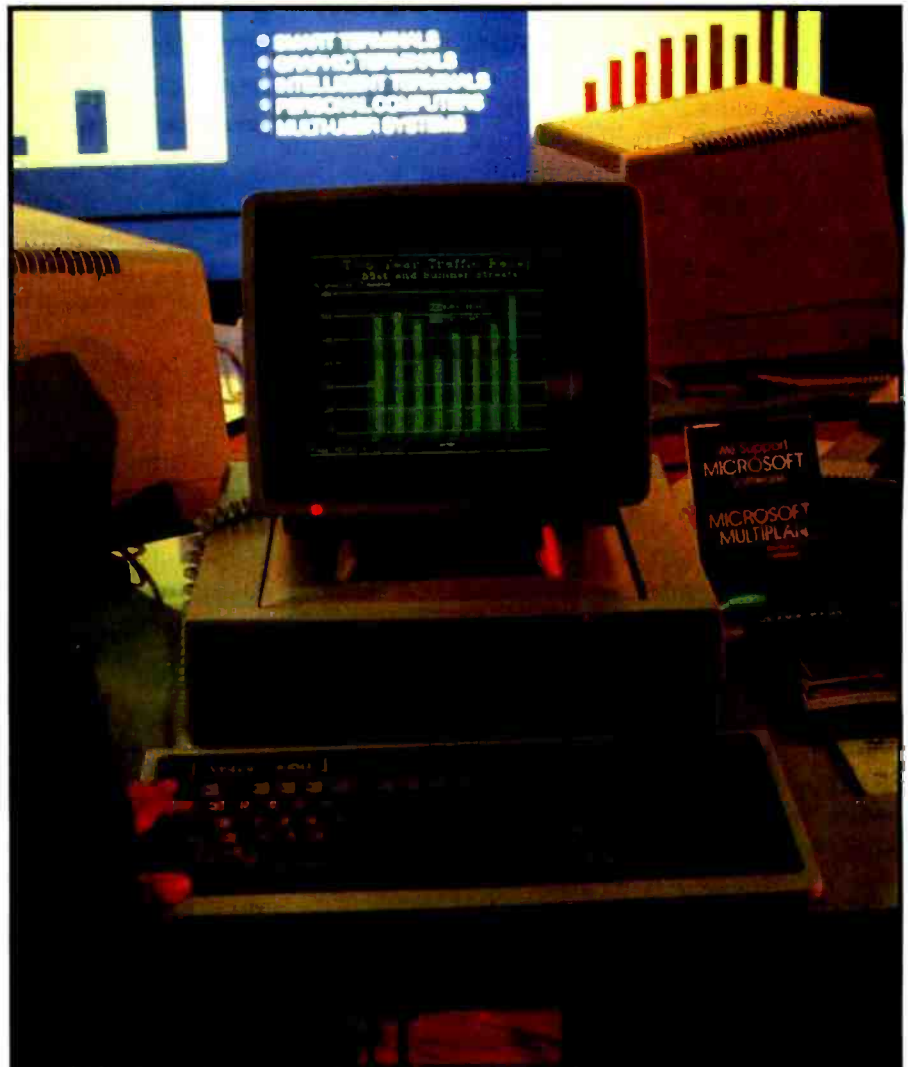



Photo 3: Visual Technology's first move from terminals to computers. This version of the 1050, with software, two drives, CP/M 3.0, and manuals, lists for \$2695. True dot graphics are displayed with text. (Photo by the author.)



Small In Price, Big In Performance

You could save lots of money by purchasing our Apple®  compatible floppy drives when you buy your computer—but don't despair, even if you have already bought your Apple or Apple compatible computer, our add-on floppy drives will still save you dollars.

Our drives are not only small in price and size but they are big in performance. Our half-high drive (41 millimeters high) is half the size of the standard Apple drive. The half-high drive provides a big 160K bytes of dual density storage running either DOS 3.2 or 3.3. Our contemporary slim line styling, cooling louvers, auto eject of diskette for operator convenience, a unique quick-release controller cable, and a fast 12 milliseconds head access time are features that you won't find at any price.

Small price, small size and big performance is not all that you get. Our 8000 hour Mean Time Between Failures is one of the highest reliability factors in the industry. That means trouble free operation!

The **WTI Half Track™** is available in both the first and second drives. The first drive comes with software, controller card, cable and a complete instruction manual. The second drive priced lower than the first, comes with cable and instruction manual. Both drives are available right now.

Apple is a trademark of Apple Computer, Inc. Half Track is a trademark of WTI Computer & Peripheral Products.

For more information, see your local computer dealer or call or write:



COMPUTER & PERIPHERAL PRODUCTS
1530 South Sinclair, Anaheim, CA 92806 (714) 978-9820

The Changing Face of Computer Graphics

Computer graphics systems are usually composed of the same basic parts. First, there's the operator, without whom not much gets done. Next is the main processor or host computer, which does the thinking. Then there's the display computer, which holds and may process the image being displayed. These pictures or images are displayed on a video monitor, which is much like the guts of your television set. The software controls everything.

Getting data into the computer requires input devices such as mice, bit pads, trackballs, keyboards, and video cameras. For more permanent image copies, there are output devices like plotters, printers, and slide cameras. Communications links, usually cables, connect all these parts. A typical computer graphics system is shown in the photo below.

The division between these parts is somewhat arbitrary; the host computer, for instance, may be part of the graphics system. There may be only one processor hosting and displaying (as in Apple Computer Inc.'s Lisa). However the parts fall together, the sum is only as fast as its weakest link. That weak link is often the controlling software.

Standards

The difficulty of moving software from one machine to another is direct-

ly proportional to the differences between the two machines. That's why the whole graphics industry has decided on some de facto standards and one formalized one. The formalized standard is the ACM/SIGGRAPH CORE standard. Unfortunately, it came along too late for universal acceptance. Many machines conform to it, but older, less ambitious standards—namely PLOT10 and FORTRAN—are still prevalent.

PLOT10 was designed by Tektronix more than 10 years ago so that FORTRAN programs could draw pictures on the then-new Tektronix graphics terminals. One Tektronix employee admitted no one ever expected PLOT10 to survive longer than five years. But like color television and the QWERTY keyboard, any standard will survive if enough units are in the field. The same reasoning applies to FORTRAN, which has become self-perpetuating. Every new machine must have a FORTRAN compiler: no one wants to rewrite that giant catalog of old programs. If this isn't depressing enough, one of the products at the NCGA show was a processor that ran FORTRAN directly in microcode.

Graphics systems come in two types: raster and vector. A television is a raster device—pictures are drawn from left to right across the screen, a line at a time. In vector graphics, the lines in a picture are drawn contiguously; to draw a

square, vector graphics draws all four sides, one at a time. (See Gregg Williams' article "A Graphics Primer," November 1982 BYTE, page 448 for more information.) Vector graphics machines are slowly losing their position; even CAD/CAM systems, the largest users of vector graphics, are switching to raster. Vector may never die out completely, but raster will be what the majority use.

Two Strategies for Generating Images

Generating computer pictures requires much data manipulation. One photo represents millions of operations by the computer. These operations can be performed either directly by special-purpose hardware or by special-purpose software running on a general-purpose computer.

Among those who generate video and film computer graphics are followers of both camps. Lucasfilm, the company that brought you the *Return of the Jedi* graphics, uses a lot of specialized hardware. Digital Productions owns a Cray-1, a very fast general-purpose mainframe, and doesn't use much specialized hardware. Both approaches have their pluses and minuses. Hardware takes longer to realize but can manipulate very quickly. Developing software that generates images takes less time than developing hardware, but the finished software isn't as fast as special-purpose hardware. A combination of new hardware and software is much more difficult to coordinate; at least some items should be "stock" or familiar.

Communications

Computers usually talk to terminals and modems in "serial" fashion: one bit at a time. The most popular method of communicating, the RS-232C port, is susceptible to noise, can work only over short distances (25 feet), and is comparatively slow (only up to about 1000 characters per second). Two much more modern methods of communicating serially are the RS-422A and RS-423A ports, but the industry, largely due to inertia, has not yet changed to these standards. It's unfortunate because these newer communications standards solve the problems of the RS-232C and run very fast. Speed is important



A complete graphics system that includes an Apple IIe (background left) and a Jupiter 7 (foreground right). Commands are entered with a Summagraphics bit-pad pointer.

because most display and host computers can run much faster than the line between them, which means screen updates (displaying new pictures) take longer than they ought to. I know of no computer company (graphics or otherwise) that uses RS-422A or RS-423A ports to move data. In the graphics field, I had hoped to see optional RS-422A on some terminals and computers, but it didn't happen this year. Sooner or later, at least one company will offer RS-422A and RS-232C ports, and the ball will roll. A really fast terminal is especially important in graphics because a nice picture can be as long as 25,000 words.

Portrait of the Computer as a Young Artist

I'm not a very good draftsman or artist. With a computer, I can draw straight lines; more important, I can erase. Artists and nonartists alike can benefit from computerized graphics systems. Nonartists benefit because another means of communication opens for them; artists benefit because the drudgery, the repetitive work is lessened. If the world wants "boilerplate" pies, bars, and lines, it can have them quickly and professionally.

Computers are great for the commercial arts, but what about the fine arts? The photo at right shows an image that could qualify as an example of either commercial or fine art. At SIGGRAPH, there is an art show just for computer graphics art.

I don't think artists will be replaced by computers. Instead, the drudge work will be automated, leaving more time for creative work. A computer can be an artist's tool, just as premade brushes are a tool. Soon, an artist will be able to walk into an art supply store and buy a new reflections package as he would a tube of gouache. This will be a sort of industrial revolution for art.

There is, however, one major controversy. When is art actually original? If I have the tools, it doesn't take long to set up the machine to make a really beautiful drawing. But I didn't do the work of painting the reflections—the computer did, with software someone else may have written. The problem will fade in importance as the public becomes more familiar with computer pictures and more demanding about



Is it commercial art or fine art? Eleanor Matthews used the Beacon Illustrator system by Florida Computer Graphics to produce this picture. The Beacon has a point resolution of 640 by 480, but the picture's resolution was increased to 2000 by 2000 with Matrix Corp.'s Lasergraphics enhancer unit. The image was then photographed with a Matrix QCR.

what it sees. The problem of judging originality should lessen as graphics acquire a history.

What It's All Good For

Education: Schools and computer graphics will go well together. Consider how much easier teaching economics would be if graphs of demand curves and gross national product could be changed instantly. If students could access and experiment with the data, "math phobia" could be conquered.

Such developments await lower prices, better software, and teacher acceptance. The first two are inevitable. An Apple or IBM PC would suffice in the classroom, although not as well as a larger machine. With the coming precipitous drops in prices, such tools could be in common use in less than five years.

Office: Computers are slowly being accepted in the workplace. Computer graphics lag behind office automation in businesses. Word processing is still used only by word-processing specialists, not by managers.

But many people entering the workforce now have grown up with com-

puters and aren't afraid to type. They will help their coworkers learn to use computers. Almost every office in middle management will have its own terminal in five years, if only because interoffice mail and electronic memos are so much easier than the paper equivalents. The trend of acceptance will slowly come to include graphics, too. After a while, almost everyone will latch on to the simple graphics triumvirate, bar/line/pie, although artists will still be called to make the more complicated drawings.

Engineering Productivity

Because there aren't enough engineers, we have to make the ones we have work faster. Blueprint changes no longer need to be a slow and tedious process. The next barrier is that every engineer will want to have a terminal on his desk rather than wait in line for one of a few terminals. When prices come down, terminals will proliferate very quickly just as soon as management realizes how much more can be accomplished. Several companies, notably Apollo and Versatec, are pushing such combined office/engineering networks.

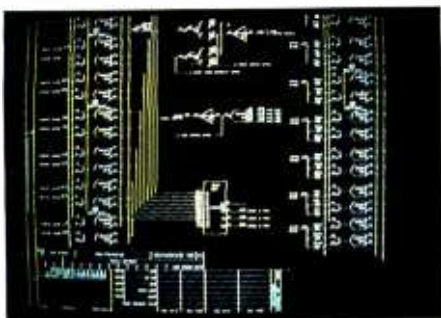

Photo 4: An example of computer-aided design. This DEC schematic demonstrates just how much detail the best equipment can show. On the original screen, you could see the tiniest writing in the bottom right corner. (Photo by the author, taken from a Conrac monitor using a Lexidata generator with DEC graphics data.)

of these terminals out on the market today and ample software, too. In a surprise move, Tektronix has brought out a relatively low-cost line of terminals that emulate both a VT-100 and Tektronix's own 4014 with color. At \$4000 to \$8000, the 4100 family is going to be very popular.

Last year I said that Conrac (a long-time maker of video monitors) didn't want to be overrun by the Japanese and was quickening its usually sedentary pace of product introduction. It displayed several new products, including what I thought was the best monitor at the show. It was a 19-inch 60-Hz noninterlaced model that was great to watch. Photo 4 shows an image from that monitor; I warn you that it looks better in person.

If picture quality is of major importance to you, a dedicated camera is in order. Polaroid Corp. has now entered the graphics camera market with low- to medium-priced (\$2000 to \$7500) camera packages that attach to IBM PCs or Apples and make transparencies, prints, or slides. The Videoprinter line was making impressive screen copies from an IBM PC. Lang Systems Inc., maker of the Videoslides recorder, was worried about such large competition, but its unit is more adaptable than Polaroid's. The market should support both. These cameras don't do much more than take a picture from a screen. That means the picture's

resolution—how many dots high and wide—is the same as your screen's. More ambitious pictures, ones with more colors and more dots, require more ambitious hardware to smooth out jagged lines, use more natural colors, and so on. Such hardware is expensive but impressive.

If your needs are greater than your budget, a graphics service bureau, which takes your data and returns finished graphics, is still the way to go. Hardware investments are lower because most of the expensive equipment is theirs, not yours. You send your picture data over a modem and they photograph and return your pictures, usually in two days. Most bureaus automatically remove jags and beautify your pictures. If you're worried about others seeing your valuable data, most service bureaus will send your pictures back undeveloped. Bureaus charge between \$5 and \$15 a slide (less for large orders).

True 3-D was before its time and remains a pretty sideshow. Obviously, true three-dimensional display (as compared to three-dimensional projection on a two-dimensional picture tube) is a powerful tool, but it's yet to be perfected or accepted. I hope I'm at the show when holographic computer graphics are first demonstrated; it will be an exciting milestone.

The prize for best give-away item goes to Jupiter Systems for its "Show Hospitality Sweet," a chocolate shaped like the planet Jupiter, complete with red spot. Jupiter also showed off its new Jupiter 12, a computer graphics workstation with higher resolution than the Jupiter 7.

The Works, scheduled to be the first all-computer-graphics, full-length motion picture, is still stalled without enough capital. The world will wait another year.

Commercial graphics houses are producing. Digital Productions is handling the space footage for *The Last Starfighter*, to be released next year. The company is rumored to be working on good computer models of the human figure, too. I wish I could show you some pictures, but Digital Productions is understandably secretive.



Photo 5: The Enter Computer Sweet-P plotter fits into a briefcase and is relatively light. The pen moves in one direction only; the paper moves in the opposite direction. Enter has made plots "up to 10 feet long" on the Sweet-P using this feature. (Photo by the author.)

Networks and Graphics

Versatec's network, called the Expert, is based on the ill-marketed Xerox Star and combines office automation and CAD. Versatec (a division of Xerox) is more famous for a laser printer/plotter that intersperses pictures and text. The unit does a professional job, and I've noticed only one problem: the text doesn't look as good as phototypeset text, which I'm told is a function of how many dots per inch are laid down. The new generation of laser printers should be an improvement.

Apollo Computer Inc.'s Domain network is meant more for office automation than design, although it does both. It has some very important network features. You can access data from other nodes (terminals) as easily as from your own, which means you can get a program from your coworker's disk and run it or send files to any printer on the network. The network has some ambitious security provisions. One important security item: each terminal has a floppy disk, so you can take your data with you. Why don't the micro companies sell a network like this?

At the moment, the cost of such networks prohibits giving every user a terminal, but don't be surprised if this changes in two years.

Some Product Developments

You may have seen their ads: Enter

Introducing the powerful, multi-processing HORIZON[®] 8/16 from North Star.

The turbo-charged system with outstanding performance.

The new North Star HORIZON 8/16 microcomputer can handle up to eight individual users, supporting both 8-bit and 16-bit applications simultaneously.

Its advanced, multi-processor architecture makes this powerful performance possible. Unlike other multi-user systems, the HORIZON 8/16 doesn't load up its users on a single processor; instead, it provides a dedicated processor for each individual user—at a cost no greater than that of conventional multi-user systems.

The result? No degradation in processing performance, even when there are eight users on the system.

And North Star's industry standard S-100 bus gives you the flexibility to choose your options and tailor the system to meet your specific requirements.

What's more, the new North Star TurboDOS[®] is many times faster than standard, multi-user operating systems—and is compatible with CP/M-80[®], CP/M-86[®] and MP/M.[™]

As for reliability, over 30,000 first generation HORIZONS are still in use. And each of these can be easily upgraded to the new 8/16 architecture.

The HORIZON 8/16 outperforms everything in its class. Costs no more. And is the only multi-user micro designed to

meet your needs for today, and tomorrow—simply by plugging in the options you select.

You can discover North Star's HORIZON 8/16 at more than 1,000 computer stores and system houses nationwide. Call 800-722-STAR for the location nearest you. Or write North Star Computers, Inc., 14440 Catalina Street, San Leandro, CA 94577.



NorthStar[™]
Simply powerful solutions.



Z-80 is a registered trademark of Zilog, Inc.
TurboDOS is a registered trademark of Software
2000, Inc. CP/M-80, CP/M-86, MP/M and CP/M are
either trademarks or registered trademarks of Digital
Research Inc.
Systems serviced nationwide by MAI/Sorbus Service Division.

Circle 329 on inquiry card.

www.americanradiohistory.com

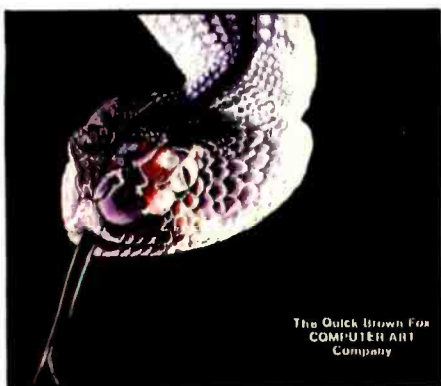

Photo 6: This image was drawn by hand. The artist used a Summagraphics bit pad and software designed for drawing by hand. The system, put together by New England Technology, uses a Jupiter 7 and an Apple IIe. (Photo by Quick Brown Fox.)

Computer Corp. has a cute little plotter it calls the Sweet-P (see photo 5). Unlike the more advanced plotters, the Sweet-P is easily interfaced to most common micros over a Centronics or RS-232C line. Enter showed the Sweet-P working on a Compaq and a Kaypro II. Plot commands can be sent in an MBASIC LPRINT statement, meaning you don't need very sophisticated software to make some rather impressive graphs. Plot pens are changed by hand. Epson America Inc., the world's largest volume-manufacturer of printers, has selected the \$795 Sweet-P as the companion to its QX-10 computer.

Eagle Computers makes more than computers: Eagle started as Audio Visual Laboratories and then branched into computers. This explains the keyboard on its IBM PC work-alikes; it has keys marked with visual terms such as "enhance." Now there is a combination product: "A complete desktop computer graphics system" that includes a digitizing pad, an 8086-based computer, a high-resolution monitor, and a camera.

Ithaca Intersystems, an S-100 computer company, brought out the Graphos VT-100-compatible color graphics terminal. The Graphos has a screen resolution of 640 by 480 pixels; it supports up to 16 windows or independent screens within the screen. Each of these windows can display 16 different colors. Graphos starts at \$8000 (a lot less than most of its competition) and can be ex-

panded to include an S-100 card cage. I asked the Ithaca people why a nice S-100 company is going into graphics, and they said they didn't want to stay a nice little S-100 company. Bravo.

Computer graphics can be created two ways: from scratch (by hand, as in photo 6) or from real-world data (photos, maps, diagrams, or any television image). The second method is called imaging, a very powerful tool. Imaging is used in medicine to "clean up" x-rays and CAT scans. Space and astronomical photographs are enhanced on similar equipment. Gould Inc.'s DeAnza Imaging and Graphics division had what I thought was the best imaging equipment at the show. DeAnza was showing images good enough to eat (see photo 7).

Color Picture Tubes

Color "bottles" are all foreign-made, mostly in Japan. The American firms have given up without a fight. American graphics companies would love to use domestic tube; it's often the only foreign-built part in their machines. But unless some more elegant display method comes along, the foreign monopoly is likely to continue.

There's still no replacement for the television picture tube. IBM announced a step toward it at NCC: a dense plasma display (July 1983 BYTE, page 297) which it had working on a PC. The display doesn't offer color and it isn't cheap, but the only vacuum tube most of us use is closer to being replaced. I won't be sorry to

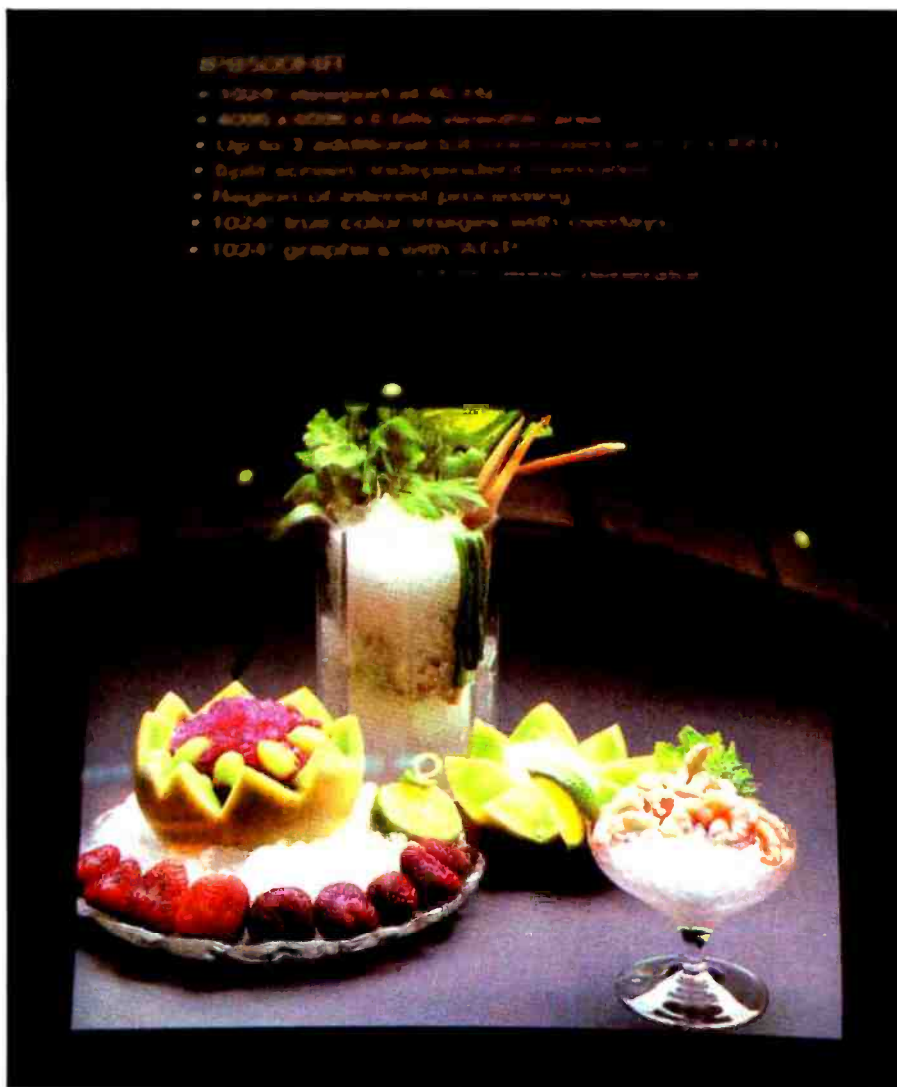

Photo 7: Tasty imaging. This picture was first taken with a high-quality television camera, digitized, then stored on disk; what you see here was shot from a monitor. Such images can be called up at any time and manipulated; you could zoom in, enhance one section of the picture, save that result, then return to the original. (Photo by the author.)

New! Only PC Saver protects your computer 2 ways:

1. Filters current from wall outlet

The reality is that power from your wall outlet is far from pure. There is AC line noise—Radio Frequency Interference or RFI—which is the cause of snow on

your TV screen when an appliance is switched on. Line noise is interpreted by your PC as data. The results? Errors. Crashed programs. Memory losses.

Surges—a sudden increase in power; and spikes—sharp, high voltage transients add to the pollution. Caused by the start/stop of inductive

devices, distant lightning, even electric company power rerouting, they too can confuse the computer or even damage the PC's intricate circuits.

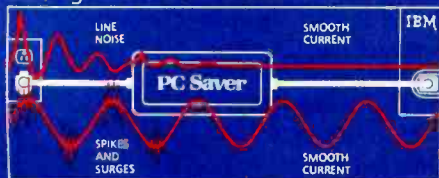

2. Stops "Feedback" noise from peripherals

For example: You connect your PC to a multi-outlet power strip containing protective circuitry. This guards against transients from the wall outlet. But then you

plug in a peripheral, such as a printer, to the same outlet strip.

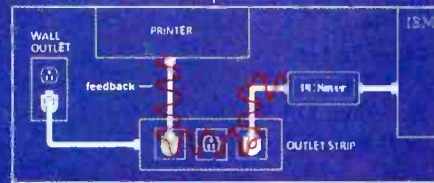

Operating the printer can generate line noise that feeds back through the outlet strip into the computer.

With the unique PC Saver replacement line cord you're protected against both sources of power problems.

An 'L' type filter attenuates common and transverse mode noise. Surges and spikes are clipped to a safe 133 volt RMS/189 Volt DC level.

Fits Most Personal Computers

The PC Saver replacement power cord fits the IBM PC and PC-XT, all Apples, DEC, Radio Shack, Compaq, and more. Also peripherals and test equipment.

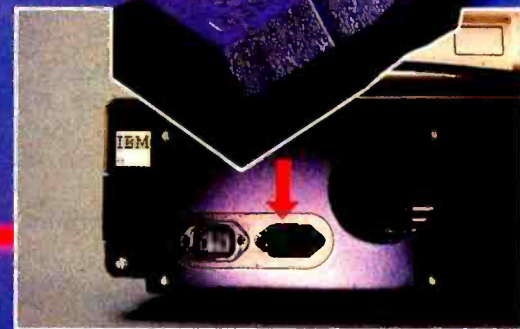

Only \$39.95 at your local dealer.

For phone or mail orders please include \$2.50 shipping and handling. New York State residents add applicable sales tax.

VISA and MASTERCARD accepted.

Kensington Microware Ltd
919 3rd Avenue, New York, NY 10022
(212) 486 7707 Tlx: 236200 KEN UR

IBM, PC and XT are trademarks of International Business Machines Corp. Apple, the Apple logo, Apple Computer, Inc. DEC, Digital Equipment Corp. PC Magazine, 21st Century Publishing, Compaq, Compaq Computer, Inc. Radio Shack, Texas

**KENSINGTON
MICROWARE**

© 1989 Kensington Microware Ltd.

PC Saver is a registered trademark of Kensington Microware Ltd. All other trademarks are the property of their respective owners.

Also available in 240/250 Volt model.

Circle 255 on inquiry card.

see it go. By decade's end, all-in-one computers and terminals will optionally come with something other than a picture tube. The tube will never die out; it's like black-and-white film—too familiar and too capable to become obsolete. But the competition will have advantages: smaller computers, lower power con-

sumption, fewer parts to align. The new displays will represent the single largest change in computer components since magnetic cores were replaced by memory chips.

Competition

The Japanese aren't here yet. They displayed a few interesting things at

the conference but remain in the wings. Most companies are running scared of their competitors, foreign and domestic; consequently, development proceeds at a fast pace. No one wants to be blind-sided, especially in an industry in which being hit unawares means waiting until the entire crowd passes over you. Because

For More Information

Slide makers and graphics photographic recorders:

Lang Systems Inc.
1392 Borregas Ave.
Sunnyvale, CA 94086
(408) 734-3332

Polaroid Corp.
575 Technology Sq.
Cambridge, MA 02139
(617) 577-2000

Sweet-P plotter:

Enter Computer Inc.
6867 Nancy Ridge Dr., Suite D
San Diego, CA 92121
(619) 450-0601

Fiber optics communications:

Artel Communications Corp.
POB 100, West Side Station
Worcester, MA 01602
(617) 752-5690

Video monitors:

Amtron Corp.
5620 Freedom Blvd.
Aptos, CA 95003
(408) 688-4445

Overhead (Vue-Graph) maker:

3M Audio Visual Division, AV82-19
POB 33600
Saint Paul, MN 55133

Jupiter series of graphics terminals:

Jupiter Systems
2126 Sixth St.
Berkeley, CA 94710
(415) 644-1024

Office automation networks with graphics:

Versatec, a division of Xerox
2710 Walsh Ave.
Santa Clara, CA 95051
(408) 988-2800

Apollo Computer Inc.
15 Elizabeth Dr.
Chelmsford, MA 01824
(617) 256-6600

Image-processing systems:

Gould Inc., DeAnza Imaging and Graphics Division
1870 Lundy Ave.
San Jose, CA 95131
(408) 263-7155

Visual 1050 personal CP/M computer with graphics:

Visual Technology Inc.
540 Main St.
Tewksbury, MA 01876
(617) 851-5000

Rampage fast graphics add-on board:

Parallax Systems Inc.
1030 East Duane Ave., Suite H
Sunnyvale, CA 94086
(408) 720-1600

Color VT-100-compatible graphics terminals:

Ithaca Intersystems Inc.
200 East Buffalo, Box 91
Ithaca, NY 14851

Tektronix Inc.

POB 500
Beaverton, OR 97077
(501) 644-0161

Graphics presentation makers (software and hardware):

New England Technology Group
400 West Cummings Park
Woburn, MA 01801
(617) 938-8833

Audio Visual Laboratories/Eagle
500 Hillside Ave.
Atlantic Highlands, NJ 07716-2197
(201) 291-4400

Antics animation software:

Grove Park Studio Animations Ltd.
104 Grove Park
Camberwell, London SE5 8LE
England

AC gas discharge plasma display:

Photonics Technology
POB 432
Luckey, OH 43443

Apple/IBM color graphics add-ons:

Number Nine Computer Engineering Inc.
POB 1802
Hartford, CT 06144
(203) 233-8134

Software for Number Nine board:

Visual Data Enterprises
POB 30563
Los Angeles, CA 90030
(213) 250-4977

Apple/IBM-based postproduction graphics equipment:

Symtec Inc.
15933 West Eight Mile Rd.
Detroit, MI 48235
(313) 272-2950

Beacon Illustrator system:

Florida Computer Graphics
1000 Sandy Pond Rd.
Lake Mary, FL 32746
(305) 321-3000

Graphics shows and associations:

National Computer Graphics Association
8401 Arlington Blvd., Suite 601
Fairfax, VA 22031

Special Interest Group on Computer Graphics (SIGGRAPH)
Association for Computing Machinery
111 East Wacker Dr.
Chicago, IL 60601
(312) 644-6610



ACEWriter II

Sophisticated word processing that's easy to learn

ACECalc

VisiCalc®-compatible spreadsheet analysis program with 80 columns of variable width

ACE Display card

Opens video display to a full 80 columns by 24 lines

ACE 80 CPU card

Allows you to run CP/M and Apple® II programs

ACE Dual Interface card

Allows you to connect to local and remote printers, terminals, computers and other accessories



Apple II compatible

64K

of RAM

Ulc

Upper & lowercase



Typewriter-style keyboard



12-key numeric pad



VisiCalc keys



50-watt power supply



Built-in fan



1982



1983

Good. Better.

And you thought Franklin was good before.

Well, look at Franklin now. You'll find our ACE product line has grown . . . and grown. To include sophisticated word processing. Sensational spreadsheet analysis. And an array of peripheral boards. So you can expand the capabilities of your ACE 1000 as your business needs increase. Our product line's not the only thing that's grown. Franklin now has more than 1,000 authorized dealers throughout the country. So, if you thought we were good before, come see us now.



FRANKLIN
COMPUTER CORPORATION
Better than ever.

Apple is a registered trademark of Apple Computer Inc.
VisiCalc is a registered trademark of Visi Corp.

2128 Route 38; Cherry Hill, NJ 08002 Telephone: 609-482-5900; Telex: 837-385

Circle 190 on inquiry card.

neither hardware nor software can do much alone, the single technological "gotcha" is not as large a worry as the company that quietly goes for two years without a major product change and then announces a whole line of new machines. No one did that at this year's show, but I wonder if it won't happen in 1984.

People frequently start graphics companies to compete with their former employers, often with direct product copies. Watch for a shakeout, with some "me-too" companies merging. One-product companies that don't branch out may find themselves in serious trouble. Will the market support four firms making exactly the same CAD/CAM equipment?

For all of you who have read Tracy Kidder's *The Soul of a New Machine*, this won't come as a surprise. Data General (DG) announced the MV/10000, a more powerful MV/8000 (the machine described in Kidder's book). The MV/8000 is a direct com-

petitor of DEC's VAX 11/780 computer, but the MV/10000 has no real competition (from DEC, anyway). One prominent DEC employee was overheard saying DEC won't have anything for at least a year and a half to compete with the MV/10000. This is a perfect example of how a single product can stomp the competition. DEC will lose customers to DG the way DG lost customers to DEC, then DEC might come out with an ultra-VAX that takes customers from the MV/10000.

Computer graphics require large amounts of data very quickly; most large color terminals have enormous cable bundles connecting them to their host. Fiber optic cables transmit over a much more modest light-conducting fiber, which Artel Corp. demonstrated by sending data from booth to booth over very thin cables. The image received wasn't quite as good as one transmitted by coaxial cable, but fiber optic lines really come into their own after about 50 feet. At

longer distances, coaxial cables are susceptible to screen interference; fiber optic cables are not.

What Next?

Within five years, I think a lot of small businesses from interior decorators to tailors will make use of graphics. Home animators, architects, and (of course) game designers already use graphics; watch for magazines like *Computer Animator*. Rock bands are already using graphics. Anyone who wants fast previews of reality without waiting for a draftsman will appreciate CAD/CAM-type systems. We can expect graphics consulting houses to spring up the same way software companies have. High-density, low-cost computer graphics are as powerful a wave as the micro-computer revolution itself. ■

Alex Pournelle is chief programmer at Workman Associates (112 Marion Ave., Pasadena, CA 91106). He also attends UC San Diego and is collaborating on a textbook. He would like to hear from people working on low-cost graphics visuals.

The SIGGRAPH Conference

The NCGA show focuses on the business side of graphics; the SIGGRAPH conference focuses on innovation. SIGGRAPHs are run by the Special Interest Group on Graphics, which is part of the Association for Computing Machinery (an organization of computer professionals, students, and academicians). The conference is officially named the "Annual Conference on Computer Graphics and Interactive Techniques," but everyone calls them SIGGRAPHs. This year's, the tenth, was held in Detroit's Cobo Hall in July.

For a novice, SIGGRAPHs are much more engaging than NCGA shows. If you're curious about what Lucasfilm is up to, want to make your own cartoons at home, or want a fast education on graphics, this conference is the place to be; you see the leading edge in computer graphics. Don't misunderstand: the two conferences are different in emphasis, not in quality. At SIGGRAPH, the emphasis is on the new, whether it's better pictures, bet-

ter machinery, faster computers, or new ways of using graphics.

The art show was worth the trip alone. There were exhibits of "pictures" (wall hangings) and "videos" (moving pictures on videotape), both ranging from fair to superior. Several pieces required less than \$15,000 in equipment, which is a modest investment in this field. Encouragingly, much of the work came from schools with computer graphics courses.

In addition to the art exhibit, there was a film and video show. About four hours of computer graphics were shown over two nights. The material ranged from pure art to pure entertainment. Demonstration reels included commercials, network logos, and presentations. Not all of the notable artistic films and videos were computer-generated; some were computer-enhanced or hybrid (analog/digital) material.

"ACT III," six minutes of graphics synchronized to Philip Glass music, was an impressive piece. "Oua Oua,"

made live by Ed Tannenbaum on his homebrew Apple-based system, was pure fun. The piece that elicited the greatest reaction from the crowd was a short segment (about 45 seconds long) from *The Works*, billed as the "first all-computer-generated, full-length motion picture." This film was started by the New York Institute of Technology's Computer Graphics Laboratory about three years ago, but lack of computing power and money have delayed its completion.

SIGGRAPH also sponsors one- and two-day courses on various topics within the field: computer-aided design (CAD), robotics, solids modeling, animation, and so on. I attended most of the Introduction to Animation course and was very impressed. I learned a lot about computer animation and how much more there is to learn.

More New Products

Because NCGA and SIGGRAPH are

Text box continued on page 380

It's easy to make points when you're a pro.

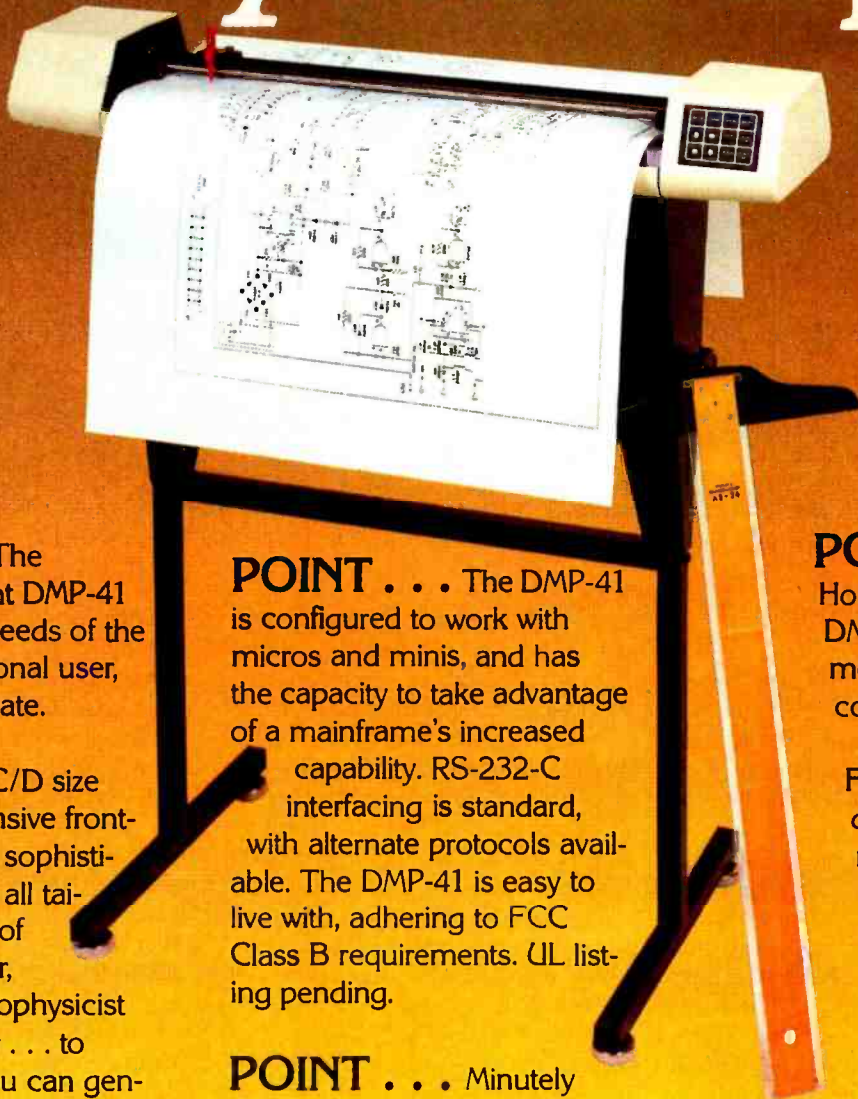

POINT . . . The Houston Instrument DMP-41 plotter meets the needs of the serious or professional user, yet it's easy to operate.

POINT . . . C/D size format, comprehensive front-panel controls and sophisticated firmware are all tailored to the needs of the surveyor, drafter, oceanographer, geophysicist and land developer . . . to name but a few. You can generate superior architectural elevations, contour maps, circuit-board layouts and assembly drawings quickly and accurately on bond, vellum or synthetic media.

POINT . . . The DMP-41 is configured to work with micros and minis, and has the capacity to take advantage of a mainframe's increased capability. RS-232-C interfacing is standard, with alternate protocols available. The DMP-41 is easy to live with, adhering to FCC Class B requirements. UL listing pending.

POINT . . . Minutely defined step size and high-resolution logic—combined with robust drives and optimized pen ballistics enable you to create plots of high precision and surpassing quality.

POINT . . . The Houston Instrument DMP-41 is one of your most cost effective considerations.*

For the name, address and phone number of your nearest distributor, write Houston Instrument, 8500 Cameron Road, Austin, Texas 78753. Phone 512-835-0900, or 800-531-5205 if outside Texas. In Europe contact Bausch & Lomb Belgium NV, Rochesterlaan 6, 8240 Gistel, Belgium. Tel 059-27-74-45, tlx 846-81339.

BAUSCH & LOMB 
houston instrument *division*

*suggested US retail \$2,995

Circle 57 on inquiry card.



A frame from an animated film produced by the Nippon Animation Co., Tokyo, using the Antics software.

Text box continued from page 378:

only a month apart, I thought SIGGRAPH would offer little new to see. But that was not the case. Several companies decided to skip NCGA and show off their new products *only* at SIGGRAPH. What follows is a short report on the newest and the best.

For the Apple II or IBM Personal Computer user, there's a new series of high-resolution color boards from Number Nine Computer Engineering (named after the Beatles' song "Revolution Number Nine"). Starting as low as \$895, this expandable board has software from Visual Data Enterprises that lets you "paint" and draw on the screen and save images on an Apple disk. Based on the cursory look I got at the system, I'd say Number Nine has a real winner. Most functions (zoom, pan, scroll, plane selection) are under software control. The board comes standard with 16 colors, 512 by 512 resolution, and RGB-TTL interface. It's definitely worth examining if you want to do some home or business graphics.

There is a lot of room between Number Nine and companies that

make equipment for the television networks. Symtec Inc. announced the PGS III system for the Apple II or IBM PC. Designed to produce graphics for low- to medium-budget video projects, this box is good for postproduction work. It can't compete with network broadcast graphics and isn't meant to. At \$2000 (black and white) to \$10,000 (deluxe color), the PGS III is much more affordable than the equipment the networks use.

Plasma screens are here and they look great if you want a big, bright, monochrome (one-color) display. Photonics Technology showed its 42- by 42-inch orange plasma display, which is only 1/2-inch thick. It's very easy to look at in any light; because it's transparent, you can put a drawing behind it for tracing. Although too expensive for the average user, expect to find them commonly used for design conferences in five years. Considering that plasma units are very large (1-meter diagonal measure), they are the most rugged thing available. The army is using them for battlefield situation displays.

IBM also believes in plasma displays.

Big Blue exhibited a plasma display, in a terminal, that can show one to four separate tasks simultaneously. The unit is a smaller version of the Photonics display. Only three things are wrong with it: it's \$7000, uses EBCDIC, and has an Egyptian keyboard. Well, hieroglyphic. The same people who brought you the most popular keyboard in America (the Selectric layout) now have one even more cryptic than the PC's. There's a little picture of an open lock on the Shift Lock key, and an arrow shaped like a reversed L on the Return key. Pardon my density, but I didn't figure out that the little open lock meant "shift lock." English is more readable than pictograms. Didn't pictograms go out with hieroglyphics?

Graphics Engines

You thought the 8087 was expensive: most graphics involve crunching a whole lot of floating-point (i.e., real) numbers. Most computers aren't very good at this alone and need an add-on box or card to increase their speed. For instance, the chip that does this for the IBM PC (and other 8086/88

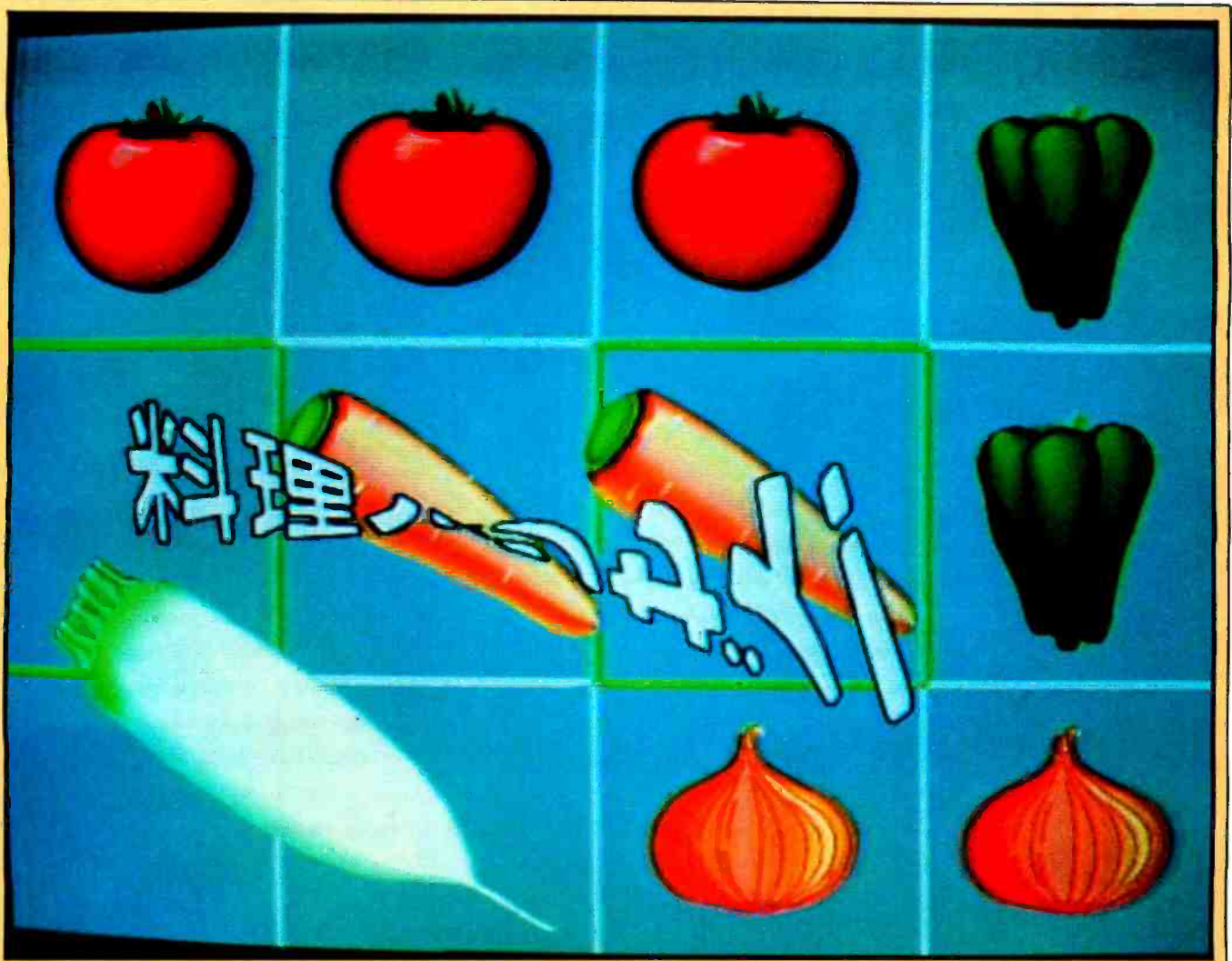

This title frame, from a sequence designed by Nippon Animation, illustrates the coloring and shading capabilities of the Antics package.

machines) is the Intel Corp. 8087, currently about \$100. Be happy that it's cheap. Real number crunching begins at "only" \$50,000 for minis. Of course, those units are incredibly fast; they are required for the sheer numbers of calculations that graphics require.

Cray Research was pushing the Cray-1 and its bigger brothers as graphics engines. Cray was the only company that didn't bring its own machine; the Cray-1 is a little hard to carry around. If the Mercedes is the sign that you've made it in Hollywood, the Cray (starting at \$5 million) is the sign that you want to compute some pretty impressive graphics.

More proof that FORTRAN will never die: the Antics animation software package is written in it. This package has been developed by a group in England called Grove Park

Studio Animations Ltd. Antics (not related to ANTIC, the graphics chip in Ataris) works with most hardware (so you can upgrade your black boxes) and allows a great variety of creature and object animation. The photos above and at left are examples of Antics graphics. We have seen only the beginning of the revolution; there are concepts and wrinkles not even thought of yet. And yet Grove Park must use a 25-year-old language for portability.

The Japanese embrace computer graphics with professional relish. They will be a force to reckon with. I expect them to use computer graphics to churn out more film animation. Currently, just about all graphics equipment (except the TV tube) is American-made, as is most innovation. But this is changing rapidly. The U.S. still

has a lead but isn't accelerating fast enough to stay ahead. I think computer graphics will become a rage in Japan like cartoon animation is now.

One problem with covering these shows is that there's too much to see. By Thursday, the day the exhibits closed, everyone was exhausted. Videos that had made people applaud or laugh on Monday were greeted with silence on Thursday. Such shows cause information overload. Even if only half the exhibitors have something worth looking at, 10 minutes per booth works out to about 14 hours of looking at equipment. Then there's the art show, the film and video show, technical lectures, parties, and classes. Five full days is barely enough time to spend at SIGGRAPH if you're trying to cover everything.



THE VICTORY FACTOR. MICROCOMPUTER ARCHITECTURE WITH NO END IN SIGHT.

Real UNIX™ Power. Real-Time Speed.

Victory Computer Systems announces the FACTOR—the first 16-bit multi-CPU computer that gives you pure UNIX programming power with real-time response. We did it with a system architecture that simultaneously implements an entire array of 16-bit single board computers. Each SBC has its own MC68000™ CPU, 256 kilobytes of dual-ported RAM, and VRTX™—a rugged, real-time software-on-silicon operating system that switches

tasks in as little as 100 μ sec. So now you can run several UNIX programs at once. Or use your FACTOR to monitor automated equipment while simultaneously processing words and data for up to 24 fully supported users.

The VMEbus. Faster by a factor of 10.

The FACTOR's CPUs communicate over the VMEbus—an advanced new backplane design with 6 card slots, 4 bus arbitration levels and 32-bit address and data paths. At 20 megabytes per

second, the non-multiplexed VMEbus is *an order of magnitude faster* than the bus implemented in today's most popular microcomputer systems. Even if you don't run a factory, the FACTOR's speed will mean faster throughput as your computing needs grow. And growth is what the Victory FACTOR is all about.

Exponential Growth. FACTORED-In.

The FACTOR's expansion-oriented architecture will take you far beyond today's performance horizons. In pro-

UNIX is a trademark of Bell Laboratories. VRTX is a trademark of Hunter & Ready Inc. Ethernet is a trademark of Xerox Corporation. MC68000 is a trademark of Motorola Inc. UNIPUS is a trademark of Unisoft, Inc. Z80 is a trademark of Zilog, Inc. CP/M is a trademark of Digital Research, Inc. *The VMEbus is supported by Philips/Signetics, Mostek, Motorola and Thompson-CSF.



cessor power. In multi-channel industrial I/O flexibility. In on-board memory. In built-in mass storage options. In the number of fully supported users. And there's no end in sight.

In designing a multi-user system with real-time speed, you've always had many factors to consider.

Now there's just one.

We've got more to tell you about the Victory FACTOR. To get the whole story, give us a call today.

System Hardware:

- Each single board computer with: 16-bit MC68000 CPU, 256 Kb dual ported RAM, VRTX real-time executive in PROM, 8 RS-232C serial ports, and a Centronics-compatible parallel port.
- New international standard 20 Mb/sec VMEbus.*
- Optional 1 Mb RAM expansion board.
- Mass storage: Hard disk, floppy disk, and removable cartridge hard disk built-in. (29-104 Mb UF)
- Fully supports Motorola 2 MHz I/O bus and industrial control interface cards.
- Alphanumeric terminals in green, international amber, or color.
- Graphics terminals in monochrome or color.
- Optional coprocessor board for concurrent execution of CP/M™ on four Z80's, each with its own 64Kb RAM.

System Software:

- UNIX (UNIPLUS™) operating system (includes "C" language).
- VRTX real-time operating system standard in PROM.
- Available languages: SMC Basic; Fortran '77; Pascal (IEEE Standard); RMCOBOL ANSI '74 Standard (Ryan-McFarland).
- Ethernet™ local area network Interface.
- 3780, and 3270 data communications protocols.

Outside CA: 1-800-221-2419
 Inside CA: 408-295-4600

Or TELEX 176-431 ANS: VICTORY SNJ
 OEM QUANTITY DISCOUNTS AVAILABLE



THE ARCHITECTURE OF INTELLIGENT COMPUTING.

©Copyright 1983 Victory Computer Systems, Inc.

2055 GATEWAY PLACE SUITE 300
 SAN JOSE, CALIFORNIA 95110

Circle 496 on inquiry card.

Echonet

Part 2: The Compiler

How Echonet produces relocatable code from English-like programs

by C. Bradford Barber

Last month, I introduced Echonet with scenarios and a comparison to other programming systems. This month I'll show how Echonet works by examples and a glossary. The first example presents the Echonet concept and the second example describes, in detail, the Echonet compiler.

In brief, programs in Echonet are *entries* and *objects* stored in an Echonet dictionary. Entries consist of an entry *name*, an entry *definition*, and the *relocatable machine code* that causes a computer to perform the entry's task. Entries are defined by instructions that indicate other entries and objects. Objects contain data used by entries.

Echonet describes programs in terms of their design. While programmers using other languages go through a cycle of establishing requirements and specifications, designing, encoding, testing, and maintenance, an Echonet user repeats a shorter cycle of idea, design, and test. The key is the Echonet dictionary, whose many entries offer a broad selection of preprogrammed functions. Each time a new program is designed, the Echonet dictionary is enhanced by that program for the next design cycle.

Programming Languages

Before studying Echonet, let's review how programming systems currently work. A programming system provides a programming language, an editor for writing programs, and an interpreter or compiler. Interpreters (e.g., most BASICs) execute a program one instruction

at a time, while compilers (e.g., FORTRAN) translate a program into machine instructions.

A programming language—whether it is compiled or interpreted—provides a fixed set of statements, operations, and data types. A language's reference manual describes:

- statements that specify actions; for example, the BASIC statement PRINT X prints the value of X
- operations that specify functions of one or more variables; for example, X + Y computes the value of X plus Y
- data types that describe variables; for example, an integer data type may be any whole number between -32768 and +32767

When you write a program, you write a sequence of instructions, comments, and declarations. The following BASIC program prints 0, 1, 2, 3, 4, 5, etc., until you interrupt it:

```
0010 REM PRINT NUMBERS
0020 LET J = 0
0030 PRINT J
0040 LET J = J + 1
0050 GO TO 30
```

Line 10 is a comment. The instruction at line 20 sets a variable, J, to zero. The instruction at line 30 prints the value of J. The instruction at line 40 increments J by adding 1 to the old value. The instruction at line 50 repeats execution starting at line 30.

This program is short. Unfortunately, useful programs

Echonet is a trademark of Echo Systems Company.

are much longer. Programs of 300 instructions, 3000 instructions, and even 10,000 instructions are common.

Invented Words, Mysterious Instructions

Programs are unusual documents. They're heavy reading in both senses of the word. They are hard to read because programs are not written in English, nor are they really written in a programming language. Let's look at the short BASIC program. Not counting line numbers and comments, it contains eight words and notations provided by BASIC: LET, =, PRINT, LET, =, +, GO, and TO. I invented the other seven words and numbers for the program: J, 0, J, J, J, 1, and 30. This is not unusual—in a typical program, almost half of the words are invented for that program or for a collection of related programs.

Besides invented words, programs contain mysterious instructions that the reader must decode. For example, line 40 of the BASIC program means "increment J" yet says "LET J = J + 1."

If a program were written once and then forgotten, an invented language wouldn't be a problem. Unfortunately, most programs are modified many times during their useful lives. Once the program is finished, it is set aside. Soon it needs enhancement or correction. The program is modified, then set aside again until the next change. Each time, the program must be read. Each time, its mysteries must be decoded and understood.

Echonet and Entries

With Echonet, you write programs as understandable phrases. Let's look at an example entry used in solving the Hanoi Tower Puzzle. Figure 1 diagrams the puzzle. The aim is to move a stack of rings from one tower to another tower. You can move the topmost ring of a tower to any other tower, but you cannot place a larger ring

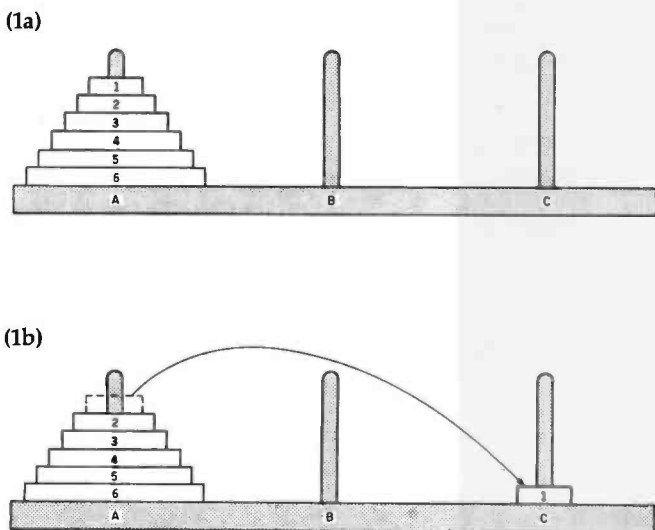

Figure 1: The Hanoi Tower Puzzle. Figure 1a shows the initial position, figure 1b the first move. The object is to transfer all the disks to another tower without ever placing a larger disk on a smaller one.

on top of a smaller ring. Listing 1 shows some of the entries used in solving the Hanoi Tower Puzzle. Each entry has an entry name shown in bold type and an entry definition written underneath. (In the following discussion, I have italicized words that have special meaning; for a glossary of these terms, see page 394.)

The first entry in listing 1 moves the topmost ring of any tower in figure 1 to any other tower. It is one step in solving the Hanoi Tower Puzzle. It has an *entry name* (**move TowerRing from HanoiTowerA to HanoiTowerB**), an *entry definition* (the three lines following the entry name), and *relocatable code* (Echonet stores relocatable code for executing the entry or *compiling* other entries).

The first entry definition in listing 1 is a sequence of three *instructions* with one instruction per line. Each instruction in the sequence starts at the same column. In this way, the visual appearance of an entry corresponds to its internal structure.

Each instruction in an entry definition *indicates* another entry. The three instructions in the first entry definition of listing 1 indicate the other three entries in listing 1. In turn, every instruction in these three entries indicates other entries (not shown) in an *Echonet dictionary*.

In an Echonet dictionary, every entry has a unique entry name. This makes all names unambiguous; given an entry name, both you and the computer can locate the entry.

Objects

In Echonet, words that start with a capital letter indicate *objects*. Table 1 lists the objects used in listing 1. Every object has an *object name* for indicating the object, *data* for describing the object, and *data types* for indicating entries by instructions. Objects are used as *arguments*, *parameters*, and *data types*.

Data typing in Echonet is a way of using objects to

Listing 1: Four entries used in solving the Hanoi Tower Puzzle. The name of each entry appears in boldface type, while its definition appears below.

move TowerRing from HanoiTowerA to HanoiTowerB

```
raise TowerRing above HanoiTowerA
move TowerRing above HanoiTowerA to HanoiTowerB
lower TowerRing onto HanoiTowerB
```

raise TowerRing above HanoiTower

```
for ScreenLine from TowerRing. .position to above. .HanoiTower
erase TowerRing on HanoiTower at ScreenLine
draw TowerRing on HanoiTower at next Higher. .ScreenLine
```

move TowerRing above HanoiTowerA to HanoiTowerB

```
on line above. .HanoiTowerA, move TowerRing from
--- HanoiTowerA to HanoiTowerB
```

lower TowerRing onto HanoiTower

```
for ScreenLine from above. .HanoiTower to onTopOf. .HanoiTower
erase TowerRing on HanoiTower at next Higher. .ScreenLine
draw TowerRing on HanoiTower at ScreenLine
```

THE BEST KEPT SECRET IS OUT.....

JUKI LETTER QUALITY, DAISY WHEEL PRINTERS ARE NOW AVAILABLE NATIONWIDE AT \$699⁰⁰



There's no mystery about it! Juki's Model 6100 bi-directional, daisy wheel printers are full featured and priced right!

Designed to perform word processing and graphic functions including bold face, subscript, superscript and shadow, the Model 6100 prints at 18 cps, has a proportional spacing control and utilizes 100 character drop-in daisy wheels. The Juki printer uses IBM Selectric Ribbons and is compatible to IBM, Apple, Osborne, Kaypro and most other personal computers. But that's no secret!

The news is that the Juki Model 6100 printers are now available through a reliable network of industry professionals strategically located throughout the country to give you the prompt, dependable sales and technical service you need. And Juki distributors are backed by a company who has been specializing in electronics for over 25 years.

So, contact the Juki distributor nearest you for the real undercover story on the best letter quality, daisy wheel printer around.



CONTACT YOUR JUKI DISTRIBUTOR FOR THE DEALER LOCATION MOST CONVENIENT FOR YOU:

ACORN DATA PRODUCTS
7304-L South Allon Way
Englewood, CO 80112
303/779-6644
Serving:
MT, WY, CO, UT, NM

BUTLER ASSOCIATES, INC.
82A Winchester Street
Newton, MA 02161
617/964-5270
Serving:
ME, NH, VT, CT, RI, MA

COMPUTER SERVICES INTERNATIONAL CORP.
905 Boulevard East
Weehawken, NJ 07087
201/866-2880
Serving: METRO NY, E. PA, NJ

GENTRY ASSOCIATES, INC.
7665 Currency Drive
Orlando, FL 32809
305/859-7450
Serving:
TN, NC, SC, MS, LA, AL, GA, FL

INFORMATION SYSTEMS, INC.
2420 E. Oakton Street, Unit K
Arlington Heights, IL 60005
312/228-5480
Serving:
WI, IL, MN, IA, MO, NE, ND, KS, SD

INTERNATIONAL BUSINESS SYSTEMS CENTER
7023 Little River Turnpike
Annandale, VA 22003
703/750-3882
Serving: MD, DE, DC, VA

OSSMANN COMPUTER TECHNOLOGIES, INC.
6666 Old Collamer Road
E. Syracuse, NY 13057
315/437-6666
Serving: UPSTATE NY

SIGMA DISTRIBUTING
2110 116th Ave. N.E.
Bellevue, WA 98005
206/454-6307
Serving:
WA, OR, ID, AK

SOUTHERN MICRO DISTRIBUTORS
8708 Royal Lane
Irving, TX 75063
214/258-6636
Serving: TX, OK, AR, LA

STAR-TRONIC DISTRIBUTOR CO.
23976 Freeway Park Drive
Farmington Hills, MI 48024
313/477-7586
Serving: MI, IN, OH, KY, PA, W. PA, WV

TECHNOLOGY MARKETING CORP.
2300 Valley View Lane
Suite 109
Dallas, TX 75234
214/243-7994
Serving: TX, OK, AR, LA

VITEK
930-G Boardwalk Avenue
San Marcos, CA 92069
619/744-8305
Serving:
S. CA

WESTERN MICRO TECHNOLOGY
10040 Bubb Road
Cupertino, CA 95014
408/725-1660
Serving: N. CA, NV, AZ

NATIONAL HEADQUARTERS: IUKI INDUSTRIES OF AMERICA, INC. DA DIVISION
299 Market Street
Saddle Brook, NJ 07662
201/368-3666

WEST COAST: IUKI INDUSTRIES OF AMERICA, INC. CALIFORNIA DIVISION
20437 South Western Avenue
Torrance, CA 90501
213/320-9001

Object Name	Data Type	Description
HanoiTower	HanoiTower	any tower in figure 1
HanoiTowerA	HanoiTower	any tower in figure 1
HanoiTowerB	HanoiTower	any tower in figure 1
ScreenLine	ScreenLine	any line of the screen
TowerRing	TowerRing	any ring on a HanoiTower

Table 1: The objects used in listing 1.

match instructions with entry names. Every object has one or more data types, and every data type is an object. An instruction matches an entry name if (1) all *name words* and *notations* in both instruction and entry name match exactly, (2) arguments and parameters occur at the same locations in both instruction and entry name, and (3) a data type of each argument is the same as a data type of the corresponding parameter. For example, the instruction "raise TowerRing above HanoiTowerA" indicates the entry **raise TowerRing above HanoiTower**, as does any instruction "raise XXXX above YYYY" where a data type of XXXX is **TowerRing** and a data type of YYYY is **HanoiTower**.

Operations

The third entry in listing 1 contains a . . (double dot), a _ _ _ (triple underscore), and a comma. The double dot makes the surrounding words ("above" and "HanoiTowerA") belong to an *operation*. The triple underscore makes the second line a continuation of the first line. The comma matches a comma in the indicated entry name.

Operations in Echonet are like value-returning function calls in a programming language. Just as with function calls, the results of operations become arguments to instructions. When Echonet looks up an instruction in an Echonet dictionary, it first replaces operations with a temporary object that is the operation's result.

In the third entry of listing 1, the operation "above. HanoiTowerA" is like a function call "getScreenLineAbove (HanoiTowerA)." It indicates the entry **ScreenLine := above. .HanoiTower**, and it is replaced by a temporary object, **TemporaryA**, whose data type is made to be **ScreenLine**. After replacing the operation, the entry's instruction would read "on line TemporaryA, move TowerRing from HanoiTowerA to HanoiTowerB," which indicates the entry on line **ScreenLine**, **move TowerRing from HanoiTowerA to HanoiTowerB**.

Indented Programs

The last feature of listing 1 is indentation that defines an *indented program*. For example, the entry **raise TowerRing above HanoiTower** indents two instructions below the first instruction. The first instruction is similar to a BASIC statement such as FOR I = 1 TO 4. It starts **ScreenLine** at "TowerRing. .position" and repeats the indented program until **ScreenLine** is "above. .HanoiTower." Each repetition erases a **TowerRing** at its current

UNIX SPOKEN HERE

and MS-DOS, and VMS too!

UniPress, your UNIX source.

We have a line of software for a range of hardware, including VAX, MC68000 and IBM PC. Source code, as well as binary. Quantity and OEM terms. Maintenance available.

PACKAGING: VAX/VMS and UNIX, MC68000/UNIX on Sun, Masscomp, Apollo, Tandy 16, Apple Lisa, Sritek Board for IBM PC, Dual, Plexus, Callan, and Cyb. Perq and Perkin Elmer, too. Inquire regarding other hardware.

UniPress Software

Priced
from

UNIX SOFTWARE

- Full UniPlus+ UNIX for Apple LISA \$ 495
- EMACS—Multi-window text editor (Gosling version) 395
- LEX—Powerful word processor 500
- PHACT—Isam file manager 250
- /RDB—Relational database tools 250
- MENU SYSTEM—Menu generation 495
- UniCalc—Powerful spreadsheet 350
- MIMIX—CP/M emulator 495
- C cross compiler—to 8086 and 68000 (includes assembler, linker, etc.) 5000

MS-DOS SOFTWARE

- Software tools—Unix-like facilities add power to MS-DOS: includes ed, grep, sort, diff, uniq, etc. . . . 200
- PHACT—Isam file manager 250
- C compiler—Full C language 395

VMS SOFTWARE

- EMACS—Multi-window text editor (Gosling version) 2500

Call or write for more information.

UniPress Software, Inc.

Dept. B10

1164 Raritan Avenue, Highland Park, NJ 08904
201-985-8000 Toll Free: 800-222-0550 (outside NJ)

Mastercard and Visa

Unix is a trademark of Bell Laboratories.
VMS is a trademark of Digital Equipment Corp.
MS-DOS is a trademark of Microsoft.
UniCalc is a trademark of Lattice, Inc.

Smith-Corona® TP-1™
 Daisy Wheel
 Printer



\$419

- Print Speed: 12 CPS
- Fully-Formed Characters
- Choice of 10 or 12 CPI Models
- Drop-in Ribbon Cassettes
- Standard Serial or Parallel
- Compatible With Most MicroComputers

MICRO MART
 8764 Complex Dr., San Diego, CA 92123
  (619) 268-0169 

Circle 561 on inquiry card.

**Touch Tone
 Decoding Modem**

Convert Touch Tones to ASCII. The Touch Tone Decoder Modem offers a low cost solution to remote monitoring and data entry applications. It autoanswers and connects any host computer's asynchronous RS-232 port with the telephone system. Select 300, 600, or 1200 baud data rate or optional external audio input. \$500 single quantity. Touch Tone send/1200 baud receive terminal available.

the microp^{er}ipheral corporation
 2565 152nd Avenue NE
 Redmond, WA 98052
 (206) 881-7544

Circle 562 on inquiry card.

**ANNOUNCING SAVINGS FOR
 MAIL ORDER BUYERS**

Have you spent too much time looking at every mail order ad for computer products to find the lowest price? Now you can save time and money with the **MAIL ORDER REPORTER (MORE)**, a consumer service which provides a comprehensive list of mail order dealers side by side with the current prices for their products. At a glance you can determine which dealers sell the products you want at the lowest price.

SAVE \$100

As an example of how **MORE** can save you money: One dealer advertises many products at prices which are very competitive, however one of its popular items is \$100 more than a lesser known dealer's price, costing buyers needless expense. With **MORE**'s complete pricing table you would instantly see the lowest price on any item.

REPORTS ON SOFTWARE AND HARDWARE

MORE presents two complete reports—one for software and one for hardware. **MORE's Software Report** includes: word processors, spreadsheets, databases, communications, financial/accounting programs and others. **MORE's Hardware Report** includes: printers, monitors, hard disks, modems, diskettes and others.

FREE GUIDE TO MAIL ORDER

If you order by October 20th you will receive free a copy of **MORE's** Guide to trouble free mail order buying.

ACT NOW

MORE'S SOFTWARE REPORT	\$ 9.95*
MORE'S HARDWARE REPORT	9.95*
Extra Value—both for only	17.50*

*CA residents add 6-1/2% sales tax.

CALL: 800-227-3800 EXT 43
 (Mastercard and VISA only) or MAIL a check or money order to:
MORE
 P.O. BOX 880953
 San Francisco, CA 94188-0953

Circle 563 on inquiry card.

position and redraws it one line higher. The first instruction contains two operations that indicate entries **ScreenLine := TowerRing.** position and **ScreenLine := above.** **HanoiTower.**

Because the first parameter of each entry is **ScreenLine**, and the data type of an indented program is **IndentedProgram**, the first instruction indicates the entry for **ScreenLine** from **ScreenLineA** to **ScreenLineB** **IndentedProgram**.

Entries in Echonet are like words in a dictionary. As with words, people will use them many times.

As described below, an indented program is compiled into relocatable code for an entry. A similar construct, not used in this example, is an *embedded clause*. Its main purpose is to embed conditional expressions into relocatable code (e.g., "while A = B do . . ." contains A = B as an embedded clause).

A Review of Entries

The entries in listing 1 illustrate several properties of Echonet:

- Echonet divides programs into components called entries and objects.
- Objects contain data. Object names start with a capital letter (e.g., **TowerRing**).
- Every entry has a multiword name that describes the entry (e.g., **move TowerRing from HanoiTowerA to HanoiTowerB**).
- Entries are defined by instructions that indicate entries and objects. Instructions may include operations or embedded clauses.

Entries in Echonet are like words in a dictionary. Entries are durable. As with words, people will use them many times. Instead of starting from scratch—inventing variable names, procedure names, and program names—Echonet users build upon an Echonet dictionary of entries and objects written by many people. Instead of encoding their programs in an invented language, Echonet users write their programs in a language made from entries.

Relocatable Code

Unlike words in a dictionary, Echonet entries contain relocatable code for execution by a computer. Echonet *compiles* relocatable code for an entry by (1) dividing the entry definition into instructions, (2) locating entries and objects indicated by the instructions, and (3) creating

NEW



SANYO PLUS



The best deal in a 64K, Z-80 system just got better. Our new Sanyo Plus system now includes dual half-height, built-in ocal drives for a total formatted floppy disk capacity of .64-1.28 Megabytes.

A new feather-touch keyboard features 15 special-function keys which are enabled under both Wordstar and Sanyo Basic, a built-in palm rest and a keypad with math functions and an enter key.

Of course you still receive over \$2400 worth of extras including CP/M®, Sanyo Basic, Wordstar, Mailmerge, Spellstar, Calcstar, and Infostar (Including Datarstar and Reportstar). Plus a games disk, a 300 baud direct connect modem, modem software, a free burn and test, and more.

Yet the price remains the same.

Sanyo Plus with Graphics \$2495.

No dealers please, F.O.B. Scottsdale
Call for additional information on extended warranty, and hard disks.

\$1995



SORRY CHARLIE!

If you just bought a 16-bit PC with a 160K drive, 128K RAM, MS-DOS, a Word Processor and an Electronic Spreadsheet you're going to be sorry you read this ad. Why? Because In October, Scottsdale Systems (with considerable help from Sanyo) will give you all this and more with the introduction of the Sanyo PC Plus at \$995!

In addition, we will pretest your PC Plus system, make user copies of your software and include your choice of an Amber or Green monitor.

Not only is the Sanyo PC Plus priced less than one-third that of a comparably equipped IBM-PC®, it is also less expensive than most 8-bit computer packages. The PC Plus will run most software developed for the IBM-PC®, features expansion slots and is backed by over 50 Sanyo service centers nationwide.

Plus - Thanks to its brushed, stainless-steel finish, the Sanyo PC Plus looks more expensive, yet takes up less space.

If you haven't made your computer decision yet, give us a call. We are now taking reservations for the Sanyo PC Plus. Better safe than sorry!

PC Plus \$995
PC Deluxe call

TELEVIDEO

Local installation available via TRW.

Teletext	Call
803 w/CP/M	\$1849
803	\$1849
1603	\$2295
806	\$5111



ZENITH

400 Service Centers Nationwide.

ZF-110-22	\$2699
ZF-120-22	\$2799
ZW-110-32	\$4249
ZVM-135	\$479

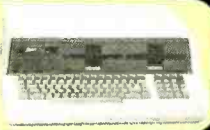

ALTOS

Altos Loves Unix

Let us Test your Altos.

5-80-2	\$1998
5-80-10	\$3649
8000-10	\$5444
5-86-10	\$6049



Call for other products/prices

TERMINALS



Adds Viewpoint 3A+ - Emulates the ADM-3A, detached keyboard, keypad, 12" green display, nationwide Adds service. \$457

Viewpoint 60	\$636
Wyse 100	\$694
Wyse 300	\$1049
Televideo 914	\$515
Televideo 924	\$666
Televideo 925	\$735
Televideo 970	\$1044
Zenith Z-29	\$656
Zenith ZT-1	\$446
Qume 102	\$544

HOUSTON INSTRUMENTS

DMP-29	\$1795
DMP-40	\$745
DMP-41	\$2340

COLUMBIA VP

\$2349

Scottsdale Systems Ltd.

617 N. Scottsdale Road, Suite B, Scottsdale, Arizona 85257

VISA (602) 941-5856 MasterCard

Call 8-5 Mon.-Fri.

We participate in arbitration for business and customers through the Better Business Bureau of Maricopa County.

SERVICE/ORDERING

INTEGRATION: Prices listed are for new equipment in factory sealed boxes with manufacturer's warranty. We will pretest your equipment. Integrate your system, configure your software, provide special tables, etc. for an additional charge. Call for prices.

ORDERING: MAIL ORDER ONLY. Prices listed are for cash. No C.O.D.'s. We sell on a Net 30 basis to Fortune 1000 companies and Universities with good credit. P.O.'s, charge cards add 2%. Az. residents add 6%. Prices subject to change, product subject to availability. Personal checks take 3 weeks to clear. 0-20% restocking fee for returned merchandise. Shipping extra - products are F.O.B. point of shipment. CP/M and MP/M are registered trademarks of Digital Research. Wordstar is a registered trademark of MicroPro International. IBM and IBM PC are registered trademarks of International Business Machines Corporation.

SOFTWARE: Sold only w/systems, not warranted for suitability.

PRINTERS



Gemini 10X	\$288
Gemini 15X	\$438
Delta 10's, 15's	Call
Epson FX-80	Call
NEC 8023A	\$398
Tally 160L/trac	\$584
Tally 180L/trac	\$799
Color IDS/All Opts.	
Prism 132	\$1469
Prism 80	\$1369



Letter Quality

Silver Reed 500	\$409
Silver Reed 550	\$654
Sanyo PR 5500	LESS
NEC 3510	\$1410
NEC 7710	\$1965

OKIDATA

The new Microline 92's and 93's feature 160 C.P.S. draft mode, 40 C.P.S. correspondence mode. Standard parallel, serial card add \$91.

Microline 92	\$489
Microline 82	\$389
Microline 93	\$835
Microline 84	\$969

DTC-380Z

Replaces the Datsywriter 2000. Uses the same printwheel, ribbons, and tractor feed. Will run serial, parallel, or IEEE 488, 48K buffer standard, uses Diablo codes.

\$1044



CP/M[®]
IBM[®]
APPLE[®]

DIRECT SOFTWARE™ DISCOUNT DIGEST

CP/M[®]
IBM[®]
APPLE[®]

TO ORDER CALL (415) 924-4744 • TOLL FREE (800) 533-3012 CA (800) 533-3011 USA

Direct Software™ Discount Prices Save \$\$ and Make Sense to Smart Buyers Who Know What They Want!!

DIRECT SOFTWARE™ MAKES PRIME PRODUCTS SO AFFORDABLE THAT THOSE IN-THE-KNOW WILL FIND IT UNWISE TO RESIST. OUR PRODUCTS ARE BACKED BY SUPPORT AND SERVICE, WITH SAME-DAY SHIPMENT ON MOST ORDERS. COMPARE OUR PRICES AND SAVE:

	List	Sale
ALPHA SOFTWARE		
Apple-IBM Connection	195	129
Data Base Manager	145	119
Data Base Manager II	295	269
Mailing List	95	65
Question	45	39
Typeface	125	79
ANDERSON—BELL		
ABSTAT	395	339
ASHTON-TATE		
Bottom Line		
Strategist	400	269
dBASE II	700	398
Financial Planner	700	479
Friday	295	239
ASPEN SOFTWARE		
Grammatik	75	56
Proof Reader	50	38
A.T.I.		
Training WordStar	75	65
Training Benchmark	75	65
Training dBASE II	75	65
Training Multiplan	75	65
BORLAND		
Menu Master	195	165
DIGITAL MARKETING		
Milestone	295	249
Datebook II	295	249
Footnote	129	109
Bibliography	125	109
Notebook	150	119
Office Filer	395	319
Hyper-Typer	49.95	39
The Micro Link II	89	79
Plan 80	295	249
DIGITAL RESEARCH		
Access Manager	300	220
Concurrent CP/M 86	350	249
CB 80 Compiler	500	369
CBASIC	150	94
SID	75	63

MULTIPLAN™
\$179
BENCHMARK™
\$299

SPECIALS

dBASE II + QUICKCODE	List 995	Sale 565
dBASE II + dUTIL	799	439
dBASE II + dGRAPH	995	565

	List	Sale
FOX & GELLER		
Quickcode	295	180
Quickscreen	149	119
dGraph	295	190
dUtil	99	58
HUMANSOFT		
DBPlus	125	95
IUS		
Easy Filer	400	249
Easy Planner	250	179
Easy Writer II	350	179
Easy Speller	125	99
Easy Speller II	225	109
General Ledger	595	359
Accounts Receivable	595	359
Accounts Payable	595	359
Order Entry	595	359
LEXISOFT		
Spellbinder	495	229
LIFETREE		
Volkswriter	195	125
LOTUS		
1-2-3	495	359
METASOFT		
Benchmark Word Processor	499	299
Benchmark Mail List	259	182
MICROPRO		
Wordstar	495	248
Wordstar/ MailMerge	645	347
Wordstar/SpellStar	645	347
Professional Pak	845	395
InfoStar	495	258
InfoStar + CP/M		
Card	495	339
Wordstar + CP/M		
Card	495	339
MailMerge	250	129
SpellStar	250	128
CalcStar	145	88

WORDSTAR™
\$248
FRIDAY™
\$239

	List	Sale
MICROSOFT		
Multiplan	275	179
BASIC 80	350	249
BASIC Compiler	395	285
FORTRAN 80	500	345
Softcard	345	248
Flight Simulator	50	38
Time Manager	150	115
MICROSTUFF		
Crosstalk	195	117
OASIS		
The Word Plus	150	105
Punctuation & Style	150	99
PERFECT SOFTWARE		
Perfect Writer	489	265
Perfect Speller	289	159
Perfect Filer	589	249
Perfect Writer/Speller	695	359
SELECT Information Systems		
Select	495	329
SORCIM		
SuperCalc	195	129
SuperCalc II	295	169
SuperWriter	395	179
SuperSpellguard	195	125
TYLOG		
DBase Window	249	199
VISICORP		
Visicalc	250	169
VisiSchedule	300	205

dBASE II™
\$398
LOTUS™
\$359



- Purchase orders accepted
- Prompt UPS Blue Label service
- Dealer institutional discounts invited
- Quantity discounts available
- Call for charges; Prices may vary

Call today for our free catalog
TO ORDER CALL
(415) 924-4744
TOLL FREE
(800) 533-3012 CA
(800) 533-3011 USA

Listing 2: Entries for demonstrating the Echonet compiler. The instructions in listing 2a clear and increment Count, while the instructions in listing 2b repeat the code of listing 2a.

<p>(2a)</p> <p>nonsense instruction</p> <p>clear Count</p> <p>increment Count</p>	<p>(2b)</p> <p>forever nonsense</p> <p>repeat</p> <p>nonsense instruction</p>
---	---

Listing 3: Entries for demonstrating the Echonet compiler (listed alphabetically). The entries in listing 3a are indicated by instructions in listing 2. The entries in listing 3b are indicated by instructions in listing 3a. Entries in listing 3c are indicated by code instructions in listings 3a, 3b, and 3c; entries not listed here are preceded by "append."

(3a)

```
clear Integer
Integer < - 0

increment Integer
Code_increment_16Bits of Count

repeat IndentedProgram
label Loop
do IndentedProgram
go to Loop
```

(3b)

```
do IndentedProgram
Code_do_program of IndentedProgram

go to Label
Code_go_to_Label of Label

Integer < - Number
Code_set_16Bits of Integer to Number

label Label
Code_define_label of Label
```

(3c)

```
CodeValue instruction
execute during compile:
append CodeValue to New_relocatable_code

CodeValue of Object
execute during compile:
append CodeValue to New_relocatable_code
append Object to New_relocatable_code

CodeValue of ObjectA to ObjectB
execute during compile:
append CodeValue to New_relocatable_code
append ObjectA to New_relocatable_code
append ObjectB to New_relocatable_code

execute during compile: IndentedProgram
Code_compiler_executes instruction
do IndentedProgram
Code_finish_executes instruction
```

new relocatable code from relocatable code stored with each indicated entry.

When Echonet compiles relocatable code for the first entry in listing 1, it concatenates relocatable code from three entries (raise TowerRing above HanoiTower, move TowerRing above HanoiTowerA to HanoiTowerB, and lower TowerRing onto HanoiTower) and stores the new relocatable code into a fourth entry (move TowerRing from HanoiTowerA to HanoiTowerB). The resulting relocatable code can execute directly. It doesn't need an operating system or an interpreter. It is like a program stored on a disk, but with two advantages: it can execute anywhere in computer memory, and other entries can use it for compiling new relocatable code.

Compiling Relocatable Code from Relocatable Code

The following will describe how Echonet compiles relocatable code. Listing 2 shows two entries: one called **nonsense instruction**, which clears and increments a count, the other called **forever nonsense**, which repeats "nonsense instruction" forever. Listings 3a, 3b, and 3c

Relocatable code for an entry is a sequence of code instructions. The sequence is compiled by concatenating shorter sequences.

show entries indicated by these instructions. Table 2 describes all objects used in the demonstration.

Relocatable code for an entry is a sequence of *code instructions*. The sequence is compiled by concatenating shorter sequences together. These shorter sequences were compiled by concatenating still shorter sequences together. The shortest sequence is a single code instruction. If you look at the definition of an entry, the definitions of each instruction, and the definitions of the instructions of the definitions of each instruction, you will in due course find code instructions. If you look at the *code* for an entry, you will find relocatable code.

Note that the entries in listing 3c reference each other. Echonet can have circular references because the meaning of an entry is different from its definition. The former is relocatable code while the latter is readable text. This difference distinguishes Echonet from programming languages such as FORTH and Smalltalk and from macro-processors used with assembly languages.

Compiling an Entry

Echonet compiles an entry by concatenating relocatable code indicated by instructions. Let's see how Echonet compiles **nonsense instruction** (from listing 2).

Step 1: The compiler looks up the first instruction,

Object Name	Data Type	Description
Code_compiler_executes	CodeValue	start compiler execution
Code_define_label	CodeValue	define a label
Code_do_program	CodeValue	compile a program
Code_finish_executes	CodeValue	finish compiler execution
Code_go_to_label	CodeValue	branch to a label
Code_increment_16Bits	CodeValue	increment a 16-bit value
Code_set_16Bits	CodeValue	set a 16-bit value
CodeValue	CodeValue	a data type that represents a numeric value for selecting a code instruction
Count	Integer	an integer counter
IndentedProgram	IndentedProgram	a data type that represents a sequence of indented instructions
Integer	Integer	a data type that represents a 16-bit value
Label	Label	a data type that represents a location's label
Loop	Label	a label for looping
New_relocatable_code	RelocatableCode	a buffer for building relocatable code
Number	Number	any numeric literal
Object	Object	a data type that represents any object in Echonet
ObjectA	Object	an Object
ObjectB	Object	an Object

Table 2: The objects used in listings 2 and 3.

"clear Count." This instruction indicates **clear Integer** (listing 3a) because **Integer** is the data type of **Count**. The compiler appends the relocatable code for **clear Integer** to the new relocatable code. It replaces the parameter **Integer** with the argument **Count**. The resulting code is:

```
new relocatable code
relocatable code for "Integer < - 0"
```

which after parameter replacement produces the same code as:

```
new relocatable code
Code_set_16Bits of Count to 0
```

Because **Count** is not a parameter of **nonsense instruction**, the compiler allocates **Count** as the first temporary value in **nonsense instruction**.

Step 2: The compiler looks up the entry for "increment Count" and finds **increment Integer** (listing 3a). It appends this entry's relocatable code to the new relocatable code and replaces the parameter **Integer** with the argument **Count**:

```
new relocatable code
Code_set_16Bits of Count to 0
Code_increment_16Bits of Count
```

Step 3: The compiler finishes the code and stores it with **nonsense instruction**. The result is:

```
relocatable code for— nonsense instruction
Code_set_16Bits of Count to 0
Code_increment_16Bits of Count
```

The entry **nonsense instruction** is no different from other entries; after an entry is compiled, it contains relocatable code. This code can be executed or used for compiling an entry. You execute an entry by writing the entry's name and pressing the function key labeled Do. If you typed in the words "nonsense instruction" and pressed Do, Echonet would look up the entry named **nonsense instruction**, load the entry's relocatable code, and execute the loaded code.

Compiling an Entry with an Indented Program

In listing 2b, I used "nonsense instruction" for defining **forever nonsense**. After compiling **nonsense instruction** Echonet has relocatable code for compiling **forever nonsense**.

Step 1: The compiler looks up the instruction "repeat" followed by an indented program. Because the data type of an indented program is **IndentedProgram**, "repeat" indicates the entry **repeat IndentedProgram** (listing 3a). Echonet had compiled this entry from three instructions:

```
relocatable code for—repeat IndentedProgram
relocatable code for "label Loop"
relocatable code for "do IndentedProgram"
relocatable code for "go to Loop"
```

which produced a sequence of code instructions:

```
relocatable code for—repeat IndentedProgram
Code_define_label of Loop
Code_do_program of IndentedProgram
Code_go_to_label of Loop
```

Step 2: The compiler appends the first code instruction of **repeat IndentedProgram**:

Hire performance.

Gifford gives you more.

When you go with Gifford, you get more than you ever thought possible from a multiuser computer system. Or a computer company. More productivity. More flexibility. More expandability. More speed. And more support.

It means *total performance* for every Gifford customer.

Gifford systems can run *both* 8 and 16-bit programs, giving you an incredible choice of over 5,000 CP/M® or MP/M™ applications. And we developed this feature, so when we say it really works, it really does.

In addition, our systems can run popular single user programs, while giving you multiuser benefits such as the ability to share resources like printers and hard disks, plus advanced security features to protect sensitive information. And you can run true multiuser programs with features like file lockout, record lockout and shared data bases.

All Gifford systems use CompuPro's proven S-100 based products, making it easy to accommodate any

performance enhancements.

For example, expansion's a snap...literally. Just snap in an expansion board, add a terminal, and you're ready to handle more. And since every system has twenty bus slots, there's plenty of power for everyone.

Gifford keeps on giving.

To make absolutely sure you get all the performance you hire, we support everything we sell. Should you ever need to call us, use our hotline to reach a knowledgeable representative.

And, if the problem can't be solved with words, it can be diagnosed via modem. If the problem is hardware related, we'll replace any defective CompuPro part within 24 hours *free* for two full years. Support continues with our two, three and five day hands-on seminars.

Meet our specs.

Just look at what our popular \$9990 three user system includes: 320K static RAM memory, two 8" DS/DD floppies, the Gifford F5-21

Winchester 21Mb drive, a CompuPro enclosure with IEEE 696/S-100 bus with 20 slots and nine I/O ports. Plus dBASEII™ SuperCalc-86™ and MP/M-86™.

Other exclusive features include time accounting for users and projects, electronic mail, system scheduler, non-destructive memory test, MP/M II queue calls, and more. As well as expansion capabilities for up to six users.

Make the cut.

If you need our kind of performance, cut the coupon or give us a call. We'll send you a free brochure detailing our exclusive high performance features, our two year warranty, and the benefits of selecting an IEEE 696/S-100 bus-based system.

But if you don't need to hire us, there's only one possible reason. You already have.

Gifford Computer Systems is a Full Service CompuPro® Systems Center.



The powerful Gifford System 321 shown with optional GCS-80 terminals.

GIFFORD
COMPUTER SYSTEMS

1922 Republic Avenue, San Leandro, CA 94577
(415) 895-0798 A division of G&G Engineering
I'D LIKE THE WHOLE STORY.
Please send me your brochure.

Name _____ Title _____
Organization _____ M/S _____
Address _____
City _____ State _____ Zip _____
Phone _____
 Please have a representative call me. By

GIFFORD COMPUTER SYSTEMS San Leandro, CA (415) 895-0798 San Francisco, CA (415) 391-4570 Los Angeles, CA (213) 477-3921
 Miami, FL (305) 665-9212 Houston, TX (713) 877-1212 Amherst, NY (716) 833-4758 Telex: 704521

Circle 193 on inquiry card.

www.americanradiohistory.com

new relocatable code
Code_define_label of Loop

Step 3: The second code instruction of **repeat IndentedProgram** is "Code_do_program of IndentedProgram." This is a special code instruction that tells the compiler to start appending relocatable code for the indented program.

Step 4: The indented program of **forever nonsense** (listing 2) consists of a single instruction, "nonsense instruction." The compiler locates the relocatable code for "nonsense instruction" and appends it to the new relocatable code:

new relocatable code
Code_define_label of Loop
Code_set_16Bits of Count to 0
Code_increment_16Bits of Count

Step 5: The compiler has finished the indented program of **forever nonsense**, so it returns to the relocatable code for **repeat IndentedProgram**.

Step 6: The compiler appends the third code instruction of **repeat IndentedProgram**:

new relocatable code
Code_define_label of Loop
Code_set_16Bits of Count to 0
Code_increment_16Bits of Count
Code_go_to_label of Loop

Step 7: The compiler is finished with the relocatable code for **repeat IndentedProgram**. It returns to the definition of **forever nonsense** (listing 2). It doesn't find any more instructions in **forever nonsense**, so it stores the new relocatable code. The result is:

relocatable code for—forever nonsense
Code_define_label of Loop
Code_set_16Bits of Count to 0
Code_increment_16Bits of Count
Code_go_to_label of Loop

Now you can execute **forever nonsense** or use it in compiling another entry. If you typed "forever nonsense" and pressed Do, Echonet would load the relocatable code stored with **forever nonsense** and start the computer executing that code. On a Z80 microcomputer, Echonet would load:

Glossary of Echonet Terms

The following glossary defines the Echonet system by defining the important words used for describing Echonet. Because Echonet is a new way of looking at programs and programming, it uses many of these familiar words in new ways. All words defined by the glossary are italicized at some point in the main text.

argument: the part of an instruction or operation that indicates an object. An argument may be an object name, an operation, an indented program, an embedded clause, a string, or a number. For example, the operation "Count + 3" has two arguments: object name **Count** and number 3.

code: data that defines a sequence of computer instructions. For example, code 60 in a Z80 microprocessor increments the accumulator.

code instruction: the smallest unit of code that Echonet can execute or use in compiling an entry. A code instruction is identified by a numeric value called a "code value." A code instruction contains data that describes its arguments. Relocatable code is a sequence of code instructions.

compile: to generate relocatable code from an entry definition and an Echonet dictionary. Echonet compiles relocatable code from relocatable code stored with entries indicated by instructions and operations.

data: a bit string stored in a computer or stored on computer-readable media. A bit string is a sequence of ones and zeros that encodes a sequence of numeric values. Everything in Echonet is ultimately represented as data stored in an Echonet dictionary.

data type: an object assigned to objects and operations that is used for indicating entries with instructions and operations. For example, the object **TowerRing** is a data type for the objects **TowerRingA** and **TowerRing**. This allows the instruction "draw TowerRingA" to indicate the entry **draw TowerRing**. Users assign data types to objects when they define an object.

Echonet dictionary: a dictionary of entries and objects accessed by unique entry names and unique object names. An Echonet dictionary stores entries and objects for a user and for groups of users. An Echonet dictionary may contain hundreds of thousands of entries and objects.

embedded clause: part of an instruction identified by an embedded-clause pattern. An embedded clause is an argument whose data type is the object **EmbeddedClause**. On compilation, an embedded clause is passed as text to the indicated relocatable code.

embedded-clause pattern: a sequence of name words, notations, and textual classes. For example, "while any-clause do" is an embedded-clause pattern.

entry: an entry name, an entry definition, and data. Many entries contain relocatable code for execution or for compiling other entries. An Echonet dictionary stores entries.

entry definition: either text or a sequence of instructions. An entry definition describes an entry. The Echonet compiler turns an entry definition into relocatable code.

entry name: a sequence of name words, notations, and object names. Instructions and operations indicate entries by entry names. Object names in an entry name indicate parameters. Each entry name is unique within an Echonet dictionary.

```

Loop:           ;;repeat
ld hl, 0       ;; nonsense instruction
inc hl
jp Loop       ;hl = Count

```

The values of **Count** would be 0, 1, 0, 1, 0, 1, 0, 1, etc.

Discussion

I named Echonet after the Echo 1 satellite, which, in 1960, introduced me to information technology. At that time, Echo 1 reflected messages from earth. Now, Echonet reflects and captures ideas for computer programs.

Research on Echonet started when I first saw assembly-language listings produced by an optimizing ALGOL compiler. Such listings, especially those for nonarithmetic programs, were verbose and convoluted. By studying these listings, I learned that high-level programming languages did not accurately specify computer actions.

Echonet resulted from my search for a programming system that could symbolically represent any sequence of computer actions. The first breakthrough was deciding to make entry names the grammar for instructions. The second breakthrough was separating entry definitions from relocatable code. This removed the need for built-

in instructions. The third breakthrough was using entries as Echonet's user interface.

One of my guiding principles was to accept the fundamental differences between people and computers. For example, computers can compute and store data far better than people can, while people recognize similarities and differences far better than computers can. The Echonet compiler connects the two by automatically translating from the personal world of symbolic entries and objects into the computer world of data and executable code. ■

Brad Barber runs Echo Systems Company (POB 5192, Westport, CT 06881), a one-person research firm. He recently joined ITT Programming as part of a research group that works on coordination systems.

Acknowledgments

Careful reviews by Terry Baker, Charles Barber, Robin Barber, Earl Gilmore, Chris LeTocq, and Gregg Williams greatly enhanced this article. My thanks to them and to the editors of BYTE for their help and encouragement.

Echonet is a research project of Echo Systems Company. To receive the next Echonet Newsletter, please send a stamped, self-addressed envelope to Newsletter, Echo Systems Company, POB 5192, Westport, CT 06881.

indented program: an indented sequence of instructions below another instruction. An indented program is an argument of the preceding instruction. The object **IndentedProgram** is the data type of an indented program.

indicate: to select an entry with an instruction or operation. Also, to select an object by matching text with an object name. An instruction or operation indicates an entry when it matches an entry name. Before matching, Echonet replaces arguments and parameters with data types. If a match fails, Echonet tries other data types for the arguments.

instruction: one line of text. An instruction can indicate an entry. Many instructions indicate entries that have relocatable code. Instructions often contain arguments.

name word: a sequence of letters, digits, and underscores that starts with a lowercase letter. Name words occur in embedded-clause patterns, entry names, and operator patterns.

notation: printable characters other than letters and digits. For example, "\$" and ">" are notations.

number: a sequence of digits. A number has the data type **Number**. For example, the instruction "print 123" indicates the entry **print Number**.

object: an object name, data types, and data. The same object can act as parameter, argument, or data type, depending on its use. An Echonet dictionary stores objects.

object name: a sequence of letters, digits, and underscores that starts with a capital letter. An object name is unique within an Echonet dictionary. Instructions and entry names indicate objects by object names.

operation: part of an instruction that matches an operator pat-

tern. An operation is an argument to an instruction or operation. Operations indicate entries whose entry names start with a parameter followed by :=. The data types of an operation are the data types of the initial parameter. For example, the instruction "print integer + 3" contains the operation "Integer +3." This operation indicates the entry **IntegerResult := Integer + Number** which has an **Integer** data type. So, this instruction indicates the entry **print Integer**.

operator pattern: a sequence of name words, notations, and textual classes. For example, "any-object-name + any-object-name" is an operator pattern. Operator patterns show the operations in an instruction.

parameter: an object indicated by an object name in an entry name. For example, the entry **print Integer** has a parameter **Integer**. In an entry definition, parameters become arguments to instructions and operations.

relocatable code: a sequence of code instructions that Echonet can execute anywhere in computer memory. Echonet uses relocatable code to compile new relocatable code. Relocatable code may contain several thousand code instructions.

string: text enclosed by quotes. A string has the data type **String**. For example, the instructions **print "this is a string"** indicates the entry **print String**.

text: characters that can appear on a page or a screen. Text may be 212 characters wide.

textual class: a pattern element that identifies an object name, a name word, a clause, end of line, or start of line; textual classes occur in operator patterns and embedded-clause patterns.

If you can beat these prices, you must have a brother-in-law in the business.

ALPHA DISKS..\$ 21.50

DISKETTES

SCOTCH 3M

S S D DEN 40 TRK. 10, 16 SECTORS	\$ 23.50
D.S.D.OEN 40 TRK. 10, 16 SECTORS	36.50
8" DISKS IN STOCK	CALL

VERBATIM DATALIFE

MD 525-01, 10, 16	\$ 26.50
MD 550-01, 10, 16	44.50
MD 557-01, 10, 16	45.60
MD 577-01, 10, 16	34.80
FD 34-4001	48.60

DISKETTE STORAGE

5 1/4" PLASTIC LIBRARY CASE	\$ 2.50
8" PLASTIC LIBRARY CASE	3.50
PLASTIC STORAGE BINDER w/ Inserts	9.95
PROTECTOR 5 1/4" (50 Disk Capacity)	21.95
PROTECTOR 8" (50 Disk Capacity)	24.95
DISK BANK 5 1/4"	5.95
DISK BANK 8"	6.95

ATARI

See Apple & Atari Software

BANK STREET WRITER	\$ 55.50
CENTPEDE	32.00
DEFENDER	32.00
DONKEY KONG	CALL
EPSON CABLE TO 850 INT.	30.00
GALAXIAN	32.00
HOME ACCOUNTANT	59.00
IN HOME KEYBOARD	67.00
PACMAN	32.00
DIX	35.00
SIGNALMAN MODEM	85.00
STAR RAIDERS	32.00
TAX ADVANTAGE	38.97
WICD TRACKBALL	59.00

INTEC PERIPHERALS RAM MODULES

48K FOR ATARI 400	\$145.00
32K FOR ATARI 800	67.00
MOSAIC 64K 400/800	169.68

PRINTERS

STAR MICRONICS GEMINI 10	\$ CALL
STAR MICRONICS GEMINI 15	CALL
RIBBONS FOR MX-80	8.95
RIBBONS FOR MX-100	24.00
C-ITOH F-10 40 CPS PARALLEL	1250.00
C-ITOH F-10 40 CPS SERIAL	1250.00
C-ITOH F-10 55 CPS PARALLEL	1639.00
C-ITOH F-10 55 CPS SERIAL	1639.00
C-ITOH PROWRITER PARALLEL	410.00
C-ITOH PROWRITER SERIAL	550.00
C-ITOH PROWRITER II PARALLEL	699.00
C-ITOH PROWRITER II SERIAL	767.00
NEW! EPSON FX-80	CALL
EPSON MX-100 W/GRAFTRAX PLUS	CALL
EPSON GRAFTRAX PLUS	60.00
EPSON RX-80	CALL
BMC PB101 PARLL or SER	730.00
COMREX CR-1 SERIAL	829.00
COMREX TRACTOR FEED	109.00
NEC 8023A	425.00

NEC SPINWRITER 3530 P. RO.	1739.00
OKIDATA MICROLINE 82A	460.00
OKIDATA MICROLINE 83A	700.00
OKIDATA MICROLINE 84	1170.00
OKIDATA 92	CALL
OKIDATA 93	CALL
OKIGRAPH 82	49.95
OKIGRAPH 83	49.95
MICROBUFFER IN-LINE 32K	299.00
MICROBUFFER IN-LINE 64K	349.00
MICROBUFFER 64K EXPANSION MOD.	179.00

BOOKS

BASIC BETTER & FASTER DEMO DISKS	18.00
CUSTOM I/O MACHINE LANGUAGE	24.95
HOW TO DO IT TRS-80	24.00
MICROSOFT BASIC FASTER & BETTER	24.95
MICROSOFT BASIC & DECODED	24.95
THE CUSTOM APPLE	24.95
THE CUSTOM TRS-80	24.95
TRS-80 DISK & MYSTERIES	16.95
Tab Books in Stock. Call For Titles.	

APPLE II/IIe HARDWARE

ABT APPLE KEYPAD	\$119.00
MICROSOFT Z-80 SOFTCARD	249.00
M & R SUPERTERM 80x24 VIDEO BD.	315.00
M & R COOLING FAN	44.95
M & R UNIVERSAL MOD.	54.95
PROMETHEUS VERSACARD	165.00
QUENTIN APPLEMATE DRIVE	258.00
SUPER CLOCK II	129.00
T/G JOYSTICK	44.95
T/G PADDLE	29.95
T/G SELECT-A-PORT	54.95
T/G TRACKBALL	47.50
THE MILL-PASCAL SPEED UP	270.00
VERSA E-Z PORT	21.95
VERSA WRITER DIGITIZER	259.00
VIDEX ULTRATERM	326.00
VIDEX 80x24 VIDEO CARD	260.00
VIDEX KEYBOARD ENHANCER II	129.00
VIDEX FUNCTION STRIP	71.50
KRAFT JOYSTICK	48.00
MICROBUFFER II 16K W/GRAPHICS	259.00
MICROBUFFER II 32K W/GRAPHICS	299.00
SUPERFAN II	62.00
SUPERFAN II W/ZENER	84.50
RANA CONTROLLER	104.00
GRAPPLER+	145.00
7710A ASYNCHRON. SER. INTERFACE	135.00
7712A SYNCHRON. SER. INTERFACE	159.00
7742A CALENDAR CLOCK	99.00
7728A CENTRONICS INTERFACE	105.00
VISTA VISION 80-80 COL. CARD	259.00

MONITORS

AMDEK COLOR I	\$350.00
AMDEK RGB COLOR II	480.00
AMDEK RGB INTERFACE	169.00
AMDEK 310A IBM AMBER	179.00
BMC GREEN MONITOR	92.00
NEC 12" GREEN MONITOR	159.00
TAXAN 12" AMBER	145.00
TAXAN RGB I	359.00
USI AMBER 9"	145.00
USI AMBER 12"	160.00

MOUNTAIN HARDWARE

COPYROM	\$ 49.00
CPS MULTIFUNCTION BOARD	145.00
EXPANSION CHASSIS	580.00
KEYBOARD FILTER ROM	49.00
MUSIC SYSTEM	369.00
RAMPLUS 32K	160.00
ROMPLUS W/ KEYBOARD FILTER	165.00
ROMPLUS W/O KEYBOARD FILTER	125.00
ROMWRITER	149.00

MODEMS

New! Hayes IBM Internal 300/1200 baud Direct Connect Modem w/soft.	\$489.00
HAYES MICROMODEM II	289.00
MICROMODEM W/ TERMINAL PKG.	309.00
HAYES 100 MODEM (S-100)	325.00
HAYES CHRONOGRAPH	199.00
HAYES SMART MODEM (300 Baud)	227.00
HAYES SMART MODEM (1200 Baud)	540.00
IBM SIGNALMAN	229.00
NOVATION J-CAT	125.00
NOVATION SMARTCAT 212	499.00
NOVATION SMARTCAT	209.00
NOVATION AUTO-CAT (1200 Baud)	619.00
NOVATION APPLE-CAT (300 Baud)	310.00
NOVATION APPLE-CAT (1200 Baud)	605.00
SIGNALMAN MODEM W/RS-232C	85.00

TRS-80 MOD I HARDWARE

LNW 5/8 DOUBLER W/DOSPLUS 3.4	\$181.00
LNW EXPANSION INTERFACE	350.00
LNW 80 MOD II W/CP/M	CALL
PERCOM DATA SEPARATOR	27.00
PERCOM DOUBLER II W/DOS 3.4	159.00
TANDON 40 TRK DISK DRIVE W/P.S.	181.00
4 DRIVE CONTROLLER P/S	259.00

IBM HARDWARE

APPARAT COMBO BOARD	\$154.00
AST	CALL
HERCULES GRAPHICS CARD	429.00
KRAFT JOYSTICK	48.00
MICROSOFT 64K	276.00
PLANTRONICS COLORPLUS GRAPHICS BOARD w/ DRAFTSMAN	475.00
QUADBOARD 64K	338.00
T/G JOYSTICK	47.95
T/G TRACKBALL	47.95
64K MEMORY UPGRADE	80.00

Davong Systems, Inc. Call for prices and stock.

ALPHA BYTE IBM MEMORY EXPANSION BOARDS

256K W/RS-232C	349.00
256K W/RS-232C & SUPERCALC 2	507.00
512K W/RS-232C	579.00
512K W/RS-232C & SUPERCALC 2	727.00

IBM DISK DRIVES

Alpha Byte's add-on drive kits for the IBM-PC — each kit includes installation instructions.	
Tandon TM100-1 Single head 40 trk.	\$195.00
Tandon TM100-2 Double head 40 trk.	262.50
TEAC HALF HEIGHT D.S. Disk Drives	279.00
BRAKETS & CABLE for half height drive	25.95
PANASONIC 1/2-HEIGHT DISK DRIVES	249.00

ISOLATORS

ISO-2 6-SOCKET	\$49.95
----------------	---------

BARE DRIVES

TANDON 5 1/4 INCH	
100-1 SINGLE HEAD 40 TRK	\$195.00
100-2 DUAL HEAD 40 TRK	262.50
100-3 SINGLE HEAD 80 TRK	250.00
100-4 DUAL HEAD 80 TRK	369.00

TANDON THINLINE 8 INCH

848-1 SINGLE SIDE	\$379.00
848-2 DUAL SIDE	490.00

MICRO PRO

APPLE CP/M	
CALCSTAR*1	\$109.00
DATASTAR*1	207.00
MAILMERGE*1	174.00
SPELLSTAR*1	174.00
SUPERSTOR*1	179.00
WORDSTAR*1	279.00

MICROSOFT®

APPLE	
ALDS††	95.00
BASIC COMPILER*	299.00
COBOL*	525.00
FORTRAN*	150.00
OLYMPIC DECATHLON	24.95
TASC APPLESOFT COMPILER	125.00
TYPING TUTOR II	16.50
Z-80 SOFTCARD	249.00

IBM SOFTWARE

BENCHMARK	\$388.70
CONCURRENT CP/M* 86	315.00
CP/M 86 DIGITAL RESEARCH	60.00
α BASE II	429.00
EASYWRITER II	247.00
EASY SPELLER	149.00
EASY FILE	285.00
FIRST CLASS MAIL	85.00
GRAPHICS HARD COPY SYSTEM	19.50
HOME ACCOUNTANT+	105.00
INFOSTAR	279.00
JFORMAT	39.00
LOTUS 1.2.3	380.00
MAILMERGE	174.00
MOVE IT	109.00
PFS FILE	97.50
PFS GRAPH	97.50
PFS REPORT	97.50
SPELLSTAR	174.00
SUPERCALC 2	168.00
THE WORD PLUS	117.00
T.J.M. III	379.00
VERSA WRITER GRAPHICS TABLETS	270.00
VISICALC / 256K	189.00
VISITREND / VISIPLLOT	235.00
VISIDEX	192.00
VISIFILE	249.00
VISISCHEDULE	229.00
VOLKSWRITER V 1.2	145.00
WORDSTAR	279.00
WRITE ON	90.00

Call for additional IBM software prices.

CP/M is a reg. trademark of Digital Research. *Requires Z-80 Softcard. †Reg. trademark of Micro Pro International Corp. ‡Trademark of Practical Peripherals, Inc. **Trademark of Software Dimensions, Inc.
MICROSOFT is reg. trademark. ††Trademark of Microsoft Corp.

S-100 HARDWARE

CALIFORNIA COMPUTER SYSTEMS

7065C 64K DYNAMIC RAM	\$ 139.00
2422 DISK CONT. & CP/M	359.00
2710 + SERIAL I/O	279.00
2719 + SERIAL / 2 PARALLEL I/O	289.00
2720 + PARALLEL I/O	279.00
2810 7.80 CPU	259.00

IBM GAME SOFTWARE

APPLE PANIC	\$ 23.61
CONQUEST	25.36
CROSSFIRE	24.95
DEADLINE	35.90
GALAXY	14.95
GO! (GO, GO)	35.36
MIDWAY CAMPAIGN	17.00
MILLIONAIRE	48.80
STARCROSS	28.00
THE WARP FACTOR	31.10
WITNESS	35.00
ZORK	28.00

If you don't see the software you want, call our software store for a complete listing.

APPLE SOFTWARE

APPLE MECHANIC	\$ 19.95
ASCII EXPRESS PRO	16.95
BANK STREET WRITER	25.00
BEARLE BIRD	25.00
BEAGLE BROTHERS	25.00
DATA CAPTURE - C 80 COLUMN	14.95
DISK MASTER VERifier	9.95
DISK MASTER VERifier II	9.95
DISK MASTER VERifier III	9.95
DISK MASTER VERifier IV	9.95
DISK MASTER VERifier V	9.95
DISK MASTER VERifier VI	9.95
DISK MASTER VERifier VII	9.95
DISK MASTER VERifier VIII	9.95
DISK MASTER VERifier IX	9.95
DISK MASTER VERifier X	9.95
DISK MASTER VERifier XI	9.95
DISK MASTER VERifier XII	9.95
DISK MASTER VERifier XIII	9.95
DISK MASTER VERifier XIV	9.95
DISK MASTER VERifier XV	9.95
DISK MASTER VERifier XVI	9.95
DISK MASTER VERifier XVII	9.95
DISK MASTER VERifier XVIII	9.95
DISK MASTER VERifier XIX	9.95
DISK MASTER VERifier XX	9.95
DISK MASTER VERifier XXI	9.95
DISK MASTER VERifier XXII	9.95
DISK MASTER VERifier XXIII	9.95
DISK MASTER VERifier XXIV	9.95
DISK MASTER VERifier XXV	9.95
DISK MASTER VERifier XXVI	9.95
DISK MASTER VERifier XXVII	9.95
DISK MASTER VERifier XXVIII	9.95
DISK MASTER VERifier XXIX	9.95
DISK MASTER VERifier XXX	9.95
DISK MASTER VERifier XXXI	9.95
DISK MASTER VERifier XXXII	9.95
DISK MASTER VERifier XXXIII	9.95
DISK MASTER VERifier XXXIV	9.95
DISK MASTER VERifier XXXV	9.95
DISK MASTER VERifier XXXVI	9.95
DISK MASTER VERifier XXXVII	9.95
DISK MASTER VERifier XXXVIII	9.95
DISK MASTER VERifier XXXIX	9.95
DISK MASTER VERifier XL	9.95
DISK MASTER VERifier XLI	9.95
DISK MASTER VERifier XLII	9.95
DISK MASTER VERifier XLIII	9.95
DISK MASTER VERifier XLIV	9.95
DISK MASTER VERifier XLV	9.95
DISK MASTER VERifier XLVI	9.95
DISK MASTER VERifier XLVII	9.95
DISK MASTER VERifier XLVIII	9.95
DISK MASTER VERifier XLIX	9.95
DISK MASTER VERifier L	9.95
DISK MASTER VERifier LI	9.95
DISK MASTER VERifier LII	9.95
DISK MASTER VERifier LIII	9.95
DISK MASTER VERifier LIV	9.95
DISK MASTER VERifier LV	9.95
DISK MASTER VERifier LVI	9.95
DISK MASTER VERifier LVII	9.95
DISK MASTER VERifier LVIII	9.95
DISK MASTER VERifier LIX	9.95
DISK MASTER VERifier LX	9.95
DISK MASTER VERifier LXI	9.95
DISK MASTER VERifier LXII	9.95
DISK MASTER VERifier LXIII	9.95
DISK MASTER VERifier LXIV	9.95
DISK MASTER VERifier LXV	9.95
DISK MASTER VERifier LXVI	9.95
DISK MASTER VERifier LXVII	9.95
DISK MASTER VERifier LXVIII	9.95
DISK MASTER VERifier LXIX	9.95
DISK MASTER VERifier LXX	9.95
DISK MASTER VERifier LXXI	9.95
DISK MASTER VERifier LXXII	9.95
DISK MASTER VERifier LXXIII	9.95
DISK MASTER VERifier LXXIV	9.95
DISK MASTER VERifier LXXV	9.95
DISK MASTER VERifier LXXVI	9.95
DISK MASTER VERifier LXXVII	9.95
DISK MASTER VERifier LXXVIII	9.95
DISK MASTER VERifier LXXIX	9.95
DISK MASTER VERifier LXXX	9.95
DISK MASTER VERifier LXXXI	9.95
DISK MASTER VERifier LXXXII	9.95
DISK MASTER VERifier LXXXIII	9.95
DISK MASTER VERifier LXXXIV	9.95
DISK MASTER VERifier LXXXV	9.95
DISK MASTER VERifier LXXXVI	9.95
DISK MASTER VERifier LXXXVII	9.95
DISK MASTER VERifier LXXXVIII	9.95
DISK MASTER VERifier LXXXIX	9.95
DISK MASTER VERifier XL	9.95
DISK MASTER VERifier XLI	9.95
DISK MASTER VERifier XLII	9.95
DISK MASTER VERifier XLIII	9.95
DISK MASTER VERifier XLIV	9.95
DISK MASTER VERifier XLV	9.95
DISK MASTER VERifier XLVI	9.95
DISK MASTER VERifier XLVII	9.95
DISK MASTER VERifier XLVIII	9.95
DISK MASTER VERifier XLIX	9.95
DISK MASTER VERifier L	9.95
DISK MASTER VERifier LI	9.95
DISK MASTER VERifier LII	9.95
DISK MASTER VERifier LIII	9.95
DISK MASTER VERifier LIV	9.95
DISK MASTER VERifier LV	9.95
DISK MASTER VERifier LVI	9.95
DISK MASTER VERifier LVII	9.95
DISK MASTER VERifier LVIII	9.95
DISK MASTER VERifier LIX	9.95
DISK MASTER VERifier LX	9.95
DISK MASTER VERifier LXI	9.95
DISK MASTER VERifier LXII	9.95
DISK MASTER VERifier LXIII	9.95
DISK MASTER VERifier LXIV	9.95
DISK MASTER VERifier LXV	9.95
DISK MASTER VERifier LXVI	9.95
DISK MASTER VERifier LXVII	9.95
DISK MASTER VERifier LXVIII	9.95
DISK MASTER VERifier LXIX	9.95
DISK MASTER VERifier LXX	9.95
DISK MASTER VERifier LXXI	9.95
DISK MASTER VERifier LXXII	9.95
DISK MASTER VERifier LXXIII	9.95
DISK MASTER VERifier LXXIV	9.95
DISK MASTER VERifier LXXV	9.95
DISK MASTER VERifier LXXVI	9.95
DISK MASTER VERifier LXXVII	9.95
DISK MASTER VERifier LXXVIII	9.95
DISK MASTER VERifier LXXIX	9.95
DISK MASTER VERifier LXXX	9.95
DISK MASTER VERifier LXXXI	9.95
DISK MASTER VERifier LXXXII	9.95
DISK MASTER VERifier LXXXIII	9.95
DISK MASTER VERifier LXXXIV	9.95
DISK MASTER VERifier LXXXV	9.95
DISK MASTER VERifier LXXXVI	9.95
DISK MASTER VERifier LXXXVII	9.95
DISK MASTER VERifier LXXXVIII	9.95
DISK MASTER VERifier LXXXIX	9.95
DISK MASTER VERifier XL	9.95
DISK MASTER VERifier XLI	9.95
DISK MASTER VERifier XLII	9.95
DISK MASTER VERifier XLIII	9.95
DISK MASTER VERifier XLIV	9.95
DISK MASTER VERifier XLV	9.95
DISK MASTER VERifier XLVI	9.95
DISK MASTER VERifier XLVII	9.95
DISK MASTER VERifier XLVIII	9.95
DISK MASTER VERifier XLIX	9.95
DISK MASTER VERifier L	9.95
DISK MASTER VERifier LI	9.95
DISK MASTER VERifier LII	9.95
DISK MASTER VERifier LIII	9.95
DISK MASTER VERifier LIV	9.95
DISK MASTER VERifier LV	9.95
DISK MASTER VERifier LVI	9.95
DISK MASTER VERifier LVII	9.95
DISK MASTER VERifier LVIII	9.95
DISK MASTER VERifier LIX	9.95
DISK MASTER VERifier LX	9.95
DISK MASTER VERifier LXI	9.95
DISK MASTER VERifier LXII	9.95
DISK MASTER VERifier LXIII	9.95
DISK MASTER VERifier LXIV	9.95
DISK MASTER VERifier LXV	9.95
DISK MASTER VERifier LXVI	9.95
DISK MASTER VERifier LXVII	9.95
DISK MASTER VERifier LXVIII	9.95
DISK MASTER VERifier LXIX	9.95
DISK MASTER VERifier LXX	9.95
DISK MASTER VERifier LXXI	9.95
DISK MASTER VERifier LXXII	9.95
DISK MASTER VERifier LXXIII	9.95
DISK MASTER VERifier LXXIV	9.95
DISK MASTER VERifier LXXV	9.95
DISK MASTER VERifier LXXVI	9.95
DISK MASTER VERifier LXXVII	9.95
DISK MASTER VERifier LXXVIII	9.95
DISK MASTER VERifier LXXIX	9.95
DISK MASTER VERifier LXXX	9.95
DISK MASTER VERifier LXXXI	9.95
DISK MASTER VERifier LXXXII	9.95
DISK MASTER VERifier LXXXIII	9.95
DISK MASTER VERifier LXXXIV	9.95
DISK MASTER VERifier LXXXV	9.95
DISK MASTER VERifier LXXXVI	9.95
DISK MASTER VERifier LXXXVII	9.95
DISK MASTER VERifier LXXXVIII	9.95
DISK MASTER VERifier LXXXIX	9.95
DISK MASTER VERifier XL	9.95
DISK MASTER VERifier XLI	9.95
DISK MASTER VERifier XLII	9.95
DISK MASTER VERifier XLIII	9.95
DISK MASTER VERifier XLIV	9.95
DISK MASTER VERifier XLV	9.95
DISK MASTER VERifier XLVI	9.95
DISK MASTER VERifier XLVII	9.95
DISK MASTER VERifier XLVIII	9.95
DISK MASTER VERifier XLIX	9.95
DISK MASTER VERifier L	9.95
DISK MASTER VERifier LI	9.95
DISK MASTER VERifier LII	9.95
DISK MASTER VERifier LIII	9.95
DISK MASTER VERifier LIV	9.95
DISK MASTER VERifier LV	9.95
DISK MASTER VERifier LVI	9.95
DISK MASTER VERifier LVII	9.95
DISK MASTER VERifier LVIII	9.95
DISK MASTER VERifier LIX	9.95
DISK MASTER VERifier LX	9.95
DISK MASTER VERifier LXI	9.95
DISK MASTER VERifier LXII	9.95
DISK MASTER VERifier LXIII	9.95
DISK MASTER VERifier LXIV	9.95
DISK MASTER VERifier LXV	9.95
DISK MASTER VERifier LXVI	9.95
DISK MASTER VERifier LXVII	9.95
DISK MASTER VERifier LXVIII	9.95
DISK MASTER VERifier LXIX	9.95
DISK MASTER VERifier LXX	9.95
DISK MASTER VERifier LXXI	9.95
DISK MASTER VERifier LXXII	9.95
DISK MASTER VERifier LXXIII	9.95
DISK MASTER VERifier LXXIV	9.95
DISK MASTER VERifier LXXV	9.95
DISK MASTER VERifier LXXVI	9.95
DISK MASTER VERifier LXXVII	9.95
DISK MASTER VERifier LXXVIII	9.95
DISK MASTER VERifier LXXIX	9.95
DISK MASTER VERifier LXXX	9.95
DISK MASTER VERifier LXXXI	9.95
DISK MASTER VERifier LXXXII	9.95
DISK MASTER VERifier LXXXIII	9.95
DISK MASTER VERifier LXXXIV	9.95
DISK MASTER VERifier LXXXV	9.95
DISK MASTER VERifier LXXXVI	9.95
DISK MASTER VERifier LXXXVII	9.95
DISK MASTER VERifier LXXXVIII	9.95
DISK MASTER VERifier LXXXIX	9.95
DISK MASTER VERifier XL	9.95
DISK MASTER VERifier XLI	9.95
DISK MASTER VERifier XLII	9.95
DISK MASTER VERifier XLIII	9.95
DISK MASTER VERifier XLIV	9.95
DISK MASTER VERifier XLV	9.95
DISK MASTER VERifier XLVI	9.95
DISK MASTER VERifier XLVII	9.95
DISK MASTER VERifier XLVIII	9.95
DISK MASTER VERifier XLIX	9.95
DISK MASTER VERifier L	9.95
DISK MASTER VERifier LI	9.95
DISK MASTER VERifier LII	9.95
DISK MASTER VERifier LIII	9.95
DISK MASTER VERifier LIV	9.95
DISK MASTER VERifier LV	9.95
DISK MASTER VERifier LVI	9.95
DISK MASTER VERifier LVII	9.95
DISK MASTER VERifier LVIII	9.95
DISK MASTER VERifier LIX	9.95
DISK MASTER VERifier LX	9.95
DISK MASTER VERifier LXI	9.95
DISK MASTER VERifier LXII	9.95
DISK MASTER VERifier LXIII	9.95
DISK MASTER VERifier LXIV	9.95
DISK MASTER VERifier LXV	9.95
DISK MASTER VERifier LXVI	9.95
DISK MASTER VERifier LXVII	9.95
DISK MASTER VERifier LXVIII	9.95
DISK MASTER VERifier LXIX	9.95
DISK MASTER VERifier LXX	9.95
DISK MASTER VERifier LXXI	9.95
DISK MASTER VERifier LXXII	9.95
DISK MASTER VERifier LXXIII	9.95
DISK MASTER VERifier LXXIV	9.95
DISK MASTER VERifier LXXV	9.95
DISK MASTER VERifier LXXVI	9.95
DISK MASTER VERifier LXXVII	9.95
DISK MASTER VERifier LXXVIII	9.95
DISK MASTER VERifier LXXIX	9.95
DISK MASTER VERifier LXXX	9.95
DISK MASTER VERifier LXXXI	9.95
DISK MASTER VERifier LXXXII	9.95
DISK MASTER VERifier LXXXIII	9.95
DISK MASTER VERifier LXXXIV	9.95
DISK MASTER VERifier LXXXV	9.95
DISK MASTER VERifier LXXXVI	9.95
DISK MASTER VERifier LXXXVII	9.95
DISK MASTER VERifier LXXXVIII	9.95
DISK MASTER VERifier LXXXIX	9.95
DISK MASTER VERifier XL	9.95
DISK MASTER VERifier XLI	9.95
DISK MASTER VERifier XLII	9.95
DISK MASTER VERifier XLIII	9.95
DISK MASTER VERifier XLIV	9.95
DISK MASTER VERifier XLV	9.95
DISK MASTER VERifier XLVI	9.95
DISK MASTER VERifier XLVII	9.95
DISK MASTER VERifier XLVIII	9.95
DISK MASTER VERifier XLIX	9.95
DISK MASTER VERifier L	9.95
DISK MASTER VERifier LI	9.95
DISK MASTER VERifier LII	9.95
DISK MASTER VERifier LIII	9.95
DISK MASTER VERifier LIV	9.95
DISK MASTER VERifier LV	9.95
DISK MASTER VERifier LVI	9.95
DISK MASTER VERifier LVII	9.95
DISK MASTER VERifier LVIII	9.95
DISK MASTER VERifier LIX	9.95
DISK MASTER VERifier LX	9.95
DISK MASTER VERifier LXI	9.95
DISK MASTER VERifier LXII	9.95
DISK MASTER VERifier LXIII	9.95
DISK MASTER VERifier LXIV	9.95
DISK MASTER VERifier LXV	9.95
DISK MASTER VERifier LXVI	9.95
DISK MASTER VERifier LXVII	9.95
DISK MASTER VERifier LXVIII	9.95
DISK MASTER VERifier LXIX	9.95
DISK MASTER VERifier LXX	9.95
DISK MASTER VERifier LXXI	9.95
DISK MASTER VERifier LXXII	9.95
DISK MASTER VERifier LXXIII	9.95
DISK MASTER VERifier LXXIV	9.95
DISK MASTER VERifier LXXV	9.95
DISK MASTER VERifier LXXVI	9.95
DISK MASTER VERifier LXXVII	9.95
DISK MASTER VERifier LXXVIII	9.95
DISK MASTER VERifier LXXIX	9.95
DISK MASTER VERifier LXXX	9.95
DISK MASTER VERifier LXXXI	9.95
DISK MASTER VERifier LXXXII	9.95
DISK MASTER VERifier LXXXIII	9.95
DISK MASTER VERifier LXXXIV	9.95
DISK MASTER VERifier LXXXV	9.95
DISK MASTER VERifier LXXXVI	9.95
DISK MASTER VERifier LXXXVII	9.95
DISK MASTER VERifier LXXXVIII	9.95
DISK MASTER VERifier LXXXIX	9.95

CONTINENTAL SOFTWARE

F C M W/FORM LETTER	\$ 75.00
G/L A/R A/P PAYROLL	Each 165.00
PROPERTY MGMT	325.00
THE HOME ACCOUNTANT	39.95

VISICORP

DESKTOP PLAN II	\$169.00
VISICALC	169.00
VISIDEX	169.00
VISIFILES	189.00
VISIPILOT	158.00
VISISCHEDULE	229.00
VISITERM	79.00
VISITREND/VISIPILOT	229.00

CP/M® SOFTWARE

We carry CP/M® software in all popular disk formats — Northstar, Televideo, and Heath/Zenith formatted programs in stock! Call for availability and price. Most software also available on IBM.

BASE II	\$429.00
DUTIL	91.00
PASCAL/M 2-80 OR 8080	295.00
IASCAL Z	349.00
P & T CP/M® MOD 2 & 16 TRS-80	193.50
DICKCODE	230.00
SPELLGUARD	230.00
SUPERCALC 2	217.00
THE WORD PLUS	117.00

DIGITAL RESEARCH

C BASIC	\$109.00	NEWDOS/80 2.0 MOD 1.111	122.50
M/AC	82.00	OMNITERM SMART TERM MOD 1.111	89.95
PASCAL MT+ W/ SSP	429.00	PROSOFT NEWSSCRIPT MOD 1.111 w/labels	109.00
PL/1-80	439.00	SPECIAL DELIVERY MOD 1.111	119.00
ZSID	92.00	TRACKACCESS MOD 1	24.95
		X-TRA SPECIAL DELIVERY MOD 1.111	179.00

This Month's Specials:

CP/M FRONT END SPECIAL	
POWER GIVES 55 COMMANDS REG-\$169.00	\$125.50
Utilities & English Programming Commands Available for Apple, IBM PC, Dec, etc.	
\$\$\$ MILLIONAIRE STOCK MARKET SIMULATION \$\$\$	
AVAILABLE FOR IBM APPLE ATARI	\$48.50
GET READY FOR CHRISTMAS!!!	
EDUCATIONAL SOFTWARE FOR THE KIDS	
SPINNAKER Sincoperrooms I or II	\$34.95
In Search Of The Most Amazing Thing	31.16
Story Machine	27.26
KinodrComp	23.36
Facemaker	27.26
Data Drawing	38.96
ALL SPINNAKER PRODUCTS ARE AVAILABLE FOR YOUR IBM PC & PC XT Also Apple & Atari	
PROTECT YOUR INVESTMENT!	
SWITCHED SIX SOCKET VOLTAGE SPIKE PROTECTION SGL-115s ONLY	\$32.50
NEW!!! STELLAR 7	
3D GAME FOR YOUR APPLE II AND APPLE IIE	\$26.95
ATTENTION IBM USERS! Would You Like...	
AN ELECTRONIC SPREADSHEET A SPELLING PROGRAMMER WITH	
A MAILING LIST MANAGER & A POWERFUL WORD PROCESSOR WITH	
A RANDOM HOUSE ELECT. THESAURUS???	
PEACHTEXT 5000	\$258.50
CALL NOW AND RECEIVE A FREE BOX OF 10 DISKETTES WITH YOUR PEACHTEXT 5000	
APPLE IIE	
MICROSOFT CP/M 80 COLUMN 64K RAM	\$362.50
PFS FILE REPORT GRAPH each	97.50
APPLE II+	
MICROSOFT PREMIUM PAK CP/M 10K RAM	
VIDEO 80 CLM WITH SOFTWARE	\$489.00
APPLE II+ AND IIE COMPATIBLE	
MULTIPLAN 40 & 80 COLUMN OR CP/M	\$199.00
MICROSOFT MULTITOOls FOR MULTIPLAN	CALL
RANA ELITE 1 PLUS DISK DRIVE W/CONTROLLER & SOFTWARE	399.00
IBM	
CP/M 86 DIGITAL RESEARCH	\$ 94.00
JOYSTICK ADAPTOR	18.95
LOTUS 1-2-3 DATABASE W/GRAPHICS & SPREADSHEET Dos 1 or 2.0	380.00
V.CROSOFT FLIGHT SIMULATOR	58.95
MONTI CARLO MULTIFUNCTION CARD 64K	345.00
MULTIPLAN MS DOS	199.00
P.A.N.TRONICS COLOR PLUS W/DRAFTSMAN	475.00
QUADRAM QUADLINK	CALL
SUPERCALC 2 NEW SPREADSHEET FROM SORCIM	168.00

Computer Crime: A Growing Threat

The proliferation of home computers has eased illegal access to small-business computers and corporate mainframes

by Collen Gillard and Jim Smith

In this article, Collen Gillard and Jim Smith describe two facets of the computer crime problem. Gillard begins by introducing background information based on documented cases of computer crime. The names of individuals and companies have been changed to protect their privacy. Starting on page 412, Smith discusses the technical requirements of a security system designed to deter the computer criminal.

Few businesses can operate today without the help of a computer. Computer-stored data, once the province of wealthy corporations, is now available to small-business owners as well, thanks to the falling costs of microcomputers and the development of easy-to-use applications software. Unfortunately, however, this same machine that provides businesses with a competitive edge also places them at the mercy of a new type of lawbreaker—the computer criminal.

Consider this case from the files of the International Association of Computer Crime Investigators (IACCI), headquartered in Burlingame, California:

In San Jose, California, in 1982, a successful software company lost a key employee in a dispute over a pay raise. The disgruntled ex-employee soon began to market a similar software line. To develop a customer base, he merely turned to his home computer, equipped with a modem, for easy access to his former employer's confidential files.

From the privacy of his home, he dialed the former employer's computer and, discovering that his file had been deactivated, tried those of company employees, guessing at their passwords. After a few attempts, he penetrated the system and located proprietary product-development information as well as customer

lists. In minutes, his chief competitor's business secrets were flowing from the printer in his study.

The former employer's customers soon revealed that he was approaching them with products similar to those of his former employer, but at attractive discounts.

Knowing that their product data and customer records were confidential, the company's executives could draw only one conclusion—their computer system had been tapped. Fortunately, though, because a secret monitoring device was in place, the intrusion was identified and, after a detailed investigation, the ex-employee was apprehended and prosecuted. However, during the investigation, service for more than 50 key customers was interrupted. This case is unusual because it was detected and prosecuted. The vast majority of intrusions go undetected, and an untold number of crimes are therefore not prosecuted.

The Potential for Damage

Trade secrets and marketing data are not the only types of material threatened by the access home computers and remote terminals provide. The government stores sensitive information on its military installations, manpower, and defense plans in computer systems. Are these top-secret files safe from unauthorized access?

In the recent film, *WarGames*, a teenage computer whiz nearly launches World War III while playing what he believes to be a simulated war game with a remote computer.

Although parts of the plot may be farfetched, the film highlights some current realities: namely, the ease with which dial-up access is gained to an airline reservations system and a bank. Moreover, months before the film was released, a group of 12 teenagers from Milwaukee managed to gain access to computers in the nuclear-weapons laboratory at Los Alamos, New Mexico. The Milwaukee teenagers used procedures for dial-up entry and password search not unlike those used by the high-school student in the movie. In wry homage to the movie after its release, one of the Milwaukee students began to sign in to the Los Alamos computer as "Joshua," the password that enabled the computer whiz in the film to log onto the game-playing computer.

A disturbing aspect of the Los Alamos raid is a statement from one of the youths whose knowledge of the machines consisted of a six-week computer course. He described the break-in as "really easy to do. All you have to find is someone with a computer and modem. And we all have computers and modems."

The youths, aged 15 to 21, had logged onto the Los Alamos system

through dialing into the Telenet network. Such a national network requires only a local telephone number to get into the service and an account number to use it.

As one youth summed up the situation, the problem occurred because of the vulnerability of the computers. He admitted that "it got out of hand," but added that, "it's not our fault, either. There's no security in it . . . It didn't take too much intelligence to get into the things."

In this case, the violated systems contained no classified material. But what if the perpetrators had been more threatening and the computer files more sensitive?

The case of the Milwaukee youths,

who also admitted breaking into business and corporate computers, proves that illegal forays into computer systems can be as simple as the acquisition of a telephone number and a password code. Dial-up penetration of computer systems today is a serious threat to businesses large and small. For large corporations and institutions like the U.S. government, such threats can have far-reaching consequences.

In a similar case from a year ago, a student who was enrolled at Carnegie-Mellon University in Pittsburgh demonstrated the vulnerability of the military's computer systems from his dormitory room when he broke into the U.S. Department of

Defense computer network. From there, he moved onto an Air Force computer system. When discovered and questioned as to his intentions, he said he was gathering "missile plans" to publish in an underground newsletter called *TAP*.

Geoffrey Goodfellow, a systems analyst with Stanford Research Institute (SRI) International in Menlo Park, California, explains: "Once someone accesses a national network like the one used by the Department of Defense, that person has unlimited access to any of the computer systems belonging to the universities or corporations hooked to the network. In this case, the student from Carnegie-Mellon wandered in and



Photo 1: The Secure Access Unit works with a telephone and modem that provide direct-dial access to a computer. It calls back a remote terminal to verify that the user is requesting access at an authorized location.

out of systems all over the country, accessing directories, reading files—just, as the student put it, 'browsing around for something interesting.' "

The point? Casual intruders can have two effects: while browsing, they can innocently destroy records and alter operating systems; and, when they *do* find interesting information, the temptation to steal it is strong.

Fear of Publicity Cripples Awareness

Although most authorities on computer security won't speculate on how much computer criminals steal annually, all agree that the dollar figure is far into the millions. Charles Wood of SRI points out, "We will never know how many crimes go undetected and how many unreported. Many firms don't want the publicity, nor do they want to encourage other thieves. Banks, in particular, shun publicity. There is nothing like this kind of publicity to foster loss of confidence in your firm's ability to handle security."

Although solid data on losses resulting from computer crimes is not available, statistics from the F.B.I. are still illuminating. They reveal that the average amount stolen in an armed robbery is \$3000; by embezzlers, \$19,000; and by computer thieves, an astounding \$100,000.

Doug DeVries, DP security manager at Hewlett-Packard Co., warns that unless businesses act on the problem, losses from computer crime could increase in the future. Experts recommend computer security systems to protect highly vulnerable systems and curb computer crime.

The fast-moving field of computer technology has surpassed computer law and its associated areas, particularly criminal investigation. According to Bruce Goldstein, computer criminologist and founder of the IACCI, "In all the world, approximately 200 police investigators have completed technical training in this special type of criminality. Present databases indicate a far-reaching problem beyond the scope of this limited number of individuals." In-

deed, as many computer security analysts admit, part of the problem lies just in anticipating the locations of a system's vulnerability.

At one time, corporate officials thought that the highly technical nature of computers ensured their security. After observing how vulnerable those systems actually are, firms are now forming "tiger teams" to find holes in their computer security systems.

These teams are composed of computer experts in systems analysis, operating systems, applications programming, and physical security. They take a "no holds barred" approach and attack the integrity and security of an entire computer system in order to find exposures and vulnerabilities. Such teams are discovering that a multiplicity of solutions is necessary to plug security holes. Technical products include encryption devices, password and software systems, and a call-back device such as the Secure Access Unit (SAU) and its multiport cousin, the Secure Access Multiport (SAM) from a San

APPLE IIe	IBM P/C-XT	NEW PORTABLE
		
ON SALE	CALL NOW	COLUMBIA VP
\$639.00	FOR SALE PRICE	\$2359.00
COMPUTERS		
Apple compatibles..... 450 & up	Columbia 1600-1..... 2289	Columbia 1600-4..... 3494
Kaypro II or 4..... SALE	Pled Piper..... 989	SKS Nano & Pico..... CALL
Corona Desktop or Port..... 1989	Teletext Teletote..... 1229	Compaq..... CALL
Eagle 1620..... 3395	DEC Rainbow 100..... 2789	IBM, Apple are registered trade marks
PRINTERS		
Gemini 10x..... 259	NEC 3550..... 1695	JUKI 8100..... 499
Transstar 130..... 679	Epson..... CALL	
MONITORS		
Princeton Graphics HX-12..... 479	Hi-RES Amber..... 129	Order Color I..... 274
RGB..... BEST BUY	New! NEC Amber 1205m..... 154	
APPLE/FRANKLIN ACCESS. & SOFTWARE		
M.S. Prem. Softcard..... 349	Ultraterm by Videx..... 289	5 1/4" Compatible Drive..... 199
GRAPPLER (Buffered)..... CALL	Z-80 card..... 99	Graphic Printer card..... 99
Wordstar w/appli card..... 299	30 TO 60% OFF SOFTWARE!	
IBM ACCESS. AND SOFTWARE		
USI multi-display card..... 339	Monte Carlo Quatro 256K..... 399	Monte Carlo GT 256K..... 439
Quadlink by Quadram..... 469	Davong 5 meg..... 1475	Mice?..... CALL US!
Tandon TM 100-2..... 229	Wordstar..... 239	
SPECIAL		
Byte Bat..... FREE	with any computer purchase!	
5 1/4" Sentinel DS/DD (box 10) 25. ea.		

BUY DIRECT AND SAVE

All prices and products subject to change and availability.

TO ORDER (619) 291-1442

COMPUTERS and more

2420 University Ave., Suite 3, San Diego, Ca. 92104

2000 letters per hour via your personal computer



delivered in 48 hours or sooner at 26¢ a piece.

Whether it's credit and collection applications, announcements to your customers, or sales promotions for new services, our MAIL-COM software turns your personal computer into a one-button mailing house of enormous power. All you need is a modem, a personal computer, and our MAIL-COM software.

Our software allows you to link up with the U.S. Postal Service's new ECOM System. After receiving your letters via modem, the Postal Service will then print, stuff, seal and deliver the letters usually by the next day and guaranteed within 48 hours.

MAIL-COM is a complete, interactive package supporting all ECOM formats. Available now for the IBM PC (\$195.00), CP/M (\$195.00) and the Alpha Micro (\$495.00).

To order, call or write...

Digisoft Computers

1501 Third Avenue
New York, NY 10028
(212) 734-3875

Drive it for less.
 Drive it with more.
 All New Reduced Prices. And Now, BASIS:
 CUSTOMIZED Perfect Writer,[™] Perfect Speller,[™]
 Perfect Filer,[™] and Perfect Calc,[™] Free.



Some people drive fine German machines to work. Other people drive them once they arrive.

The tradition of high quality, high performance German craftsmanship and engineering is legend. And while we most often see that tradition in action on America's streets and highways, it is in America's business offices that its future holds the most promise.

The BASIS 108 is the proof.

This powerful small business computer passes higher-priced competitors with ease. Its dual processors — for CP/M[®] and Apple II[®] compatibility — open up the largest library of microcomputer software and plug-in peripherals available today. This unique combination also provides compatibility with other popular languages, including Pascal[™] and LOGO.

The lightweight, low profile, detached keyboard is a work of art and practicality. There's a full 128-key ASCII character set. Fifteen user-definable function keys that can provide access to 60 distinct functions. A nine-key cursor control block. And a convenient eighteen-key numeric pad.

And there's more. RGB and composite NTSC or PAL video. Keyboard-selectable 80 or 40 column display. High resolution color graphics. Parallel and serial printer interfaces. Easily accessible outboard I/O connectors. Six Apple II-compatible card slots for peripherals expansion.

The BASIS 108. Microcomputing's "Best Of Both Worlds" German craftsmanship and American business savvy. CP/M-based business computing and Apple II-based personal computing. High performance and surprisingly low cost.

The BASIS 108. A computing machine finely tuned to handle the fast tracks of business today, particularly now with a bundled-in Perfect Software Package[™] that includes Perfect Writer,[™] Perfect Speller,[™] Perfect Filer,[™] and Perfect Calc.[™] Call your BASIS dealer for a test drive.



BASIS

Exclusively Distributed in North America by:



Computer System Designs
 99 Danbury Rd., Ridgefield, CT 06877
 (203) 431-4540, (800) 222-0626
 Ontario, CA (714) 947-5727
 Montreal (514) 636-8363
 Toronto (416) 281-3625

Circle 56 on inquiry card.

CP/M[®] is a registered trademark of Digital Research, Inc. Apple II[®] is a registered trademark of Apple Computer, Inc. Pascal[™] is a trademark of the Regents of the University of California at San Diego. Perfect Software, Perfect Writer, Perfect Speller, Perfect Filer, and Perfect Calc are trademarks of Perfect Software, Inc.

Francisco company named LeeMAH. These devices restrict outside dial-ups to certain authorized locations. All function best when employed together to secure a system. No single solution can do the job.

A Different Kind of Culprit

In a sense, computer crimes do not differ significantly from more traditional crimes. As SRI computer security specialist Donn Parker and his associate Charles Wood explain, such crimes as fraud, theft, larceny, embezzlement, extortion, sabotage, es-

pionage, and violation of privacy have the same results regardless of the means used. Yet computer crime is different. "The occupations of the perpetrators, the timing of the acts, the geographic locations of the parties involved, and the environments in which these acts take place have all changed," say Parker and Wood.

Computer criminals, for example, are generally white-collar, well-educated professionals without police records. When caught, many have based effective defenses on the claim that their ethical judgment was

undermined by the impersonal nature of their act.

In his book, *Crime by Computer*, Donn Parker states that the most common characteristic among computer criminals is that, as formerly honest people, they have difficulty accepting their dishonesty. Hence, they work hard to rationalize their crimes. For example, they claim they don't steal from people, only from corporations; or, because they don't like their bosses, they say they embezzle more for revenge than personal gain and try to justify their retaliation.

Computer embezzlers often prefer to see themselves as borrowers—not thieves—who became criminals without intending to. They often have problems with alcoholism, drugs, or financial responsibilities, says Parker, adding that computer criminals are generally people who by nature seek easy solutions to complex problems.

In August of 1977 the *New Yorker* told the story of an accountant who embezzled more than \$200,000 a year from the produce-packing company where he worked. "I had a very tough job at best, organizing the accounts of a company run by people I didn't like," he said.

When he didn't get the bonus he'd been expecting, he warned, "There's one guy in this organization you shouldn't fool around with." He said his motive for embezzling was revenge.

A more recent case involved a former Federal Reserve Bank employee who illegally accessed the bank's database. The culprit was able to dial up using the password of an existing employee to obtain confidential data on money supply and interest rates.

The Hacker

For many young computer enthusiasts, though, breaking into a computer system is just a game. Such electronic whiz-kids—"hackers" in computer lingo—say they break in for the challenge, or "because it's there."

Consider, for example, the case in which workers at the New Jersey Board of Education turned on their terminals one morning to find their

DECADES OF SERVICE

Washington Computer Services

97 Spring Street
New York, New York 10012

TO ORDER: CALL OUR TOLL-FREE NUMBER: (800)221-5416

In N.Y. State and for technical information: (212) 226-2121

HOURS: 9:30 AM—5:30 PM (EST) Monday-Friday

an affiliate of **WASHINGTON ELECTRIC COMPANY** est. 1912

CUSTOM COMPUTER ROOM WIRING SINCE 1960

TELEX: 12-5606 CABLE: WASHCOMP NYK

FULLY CONFIGURED BUSINESS SYSTEMS

The following are some examples of the fully assembled and tested business and scientific computer systems which we offer:

IMS The Premier Multi-User Computer System
8000 SX, multi-processor, Turbo DOS
CPM 2.2 FULL 2 YEAR WARRANTY!
5000 IS, S-100 desk top mainframe
8000 S up to 16 user
3270 Software Available. On-Site Service Contracts Available.
IMS on GSA Contract #G500K830156035

CALL FOR CONFIGURATION

NEC APC 8086, 16 bit processor; Two 8" DSDD disk drives; 128K RAM (to 640K); green or RGB color screen.

PERFECT FOR:

- Word Processing
- CAD/CAM graphics (1024 x 1024 resolution)
- DataBase Management
- Accounting

• Chang Lab's Microplan • IBM emulations • CP/M-86, MSDOS, UCSD P.

NEC on N.Y.S. Contract #P-07220

NEC PC-8800 ON GSA CONTRACT #G500KA30156035

EPSON NEW QX-10 Micro with VALDOCS software: \$2995.
68000 16 bit multi-user, S-100, UNIX V.7

SEATTLE COMPUTER 8086 16 bit, 128K RAM, S-100, Gazelle

California Computer Systems **GODDOUT** **MORROW DESIGNS**

Under Systems **NorthStar** On GSA Contract

8 & 16 BIT BOARDS & SYSTEMS **SCALL**

SCION MicroAngelo Hi Res Graphics Systems
Similar savings on SSM, DELTA, DYNABYTE, TELEVIDEO, ALTOS, DEC, DATA GEN., ATARI, TECHMAR, ZENITH, ITHACA SYSTEM GRP., and many others!

PLEASE! Do not confuse us with mail order dealers. We are a full service distributor serving the data processing & installation needs of business & industry from micros to mainframes. System houses, educational institutions & governmental agencies given special consideration. Leasing available.

N. Y. State agencies, municipalities, and schools — call us for information on our O.G.S. term contracts on hardware & software.

DEALER and INTERNATIONAL INQUIRIES WELCOME

For fast delivery, send certified check, money order or call to arrange direct bank wire transfer. Personal or company checks require two to three weeks to clear. Prices subject to change without notice; call for latest prices. Prices include 3% cash discount. N.Y. residents add sales tax. Qantex is a trademark of North Atlantic Industries, Inc. CP/M™ is a trademark of Digital Research. All sales subject to our standard sale conditions (available on request). Call for shipping charges. Above prices do not include customization or installation. DBase II is a trademark of Ashton Tate. P.D.'s accepted upon our credit approval; call for prices and terms.

Where Do You Turn To Solve Your Computer Puzzle?



TURN TO US!

We'll show you the easiest way to put the pieces together.

Matched, Compatible, Proven—
Use Someone Else's Engineering to Supplement Yours.

SOFTWARE

Over 2000 business scientific, professional applications & educational packages are available. Call with your requirements for our advice or a quotation. We feature DBase II & Fox & Geller.

TERMINALS

TELETYPE	AMPEX	QUME
TELEVIDEO	ADDS	IBM 3101
LEAR SIEGLER	ANN ARBOR	DIGITAL EQUIP. CORP.
	VISUAL	HAZELTINE

NEW TELETYPE 5410

132 col., ANSI, VT-100 compatible.
ONLY \$895



PRINTERS

Teletype 40, 300 LPM-typewriter quality, RS-232 interface. This quality printer is available in many configurations including forms access, queitized case, etc.
Teletype 43 from \$995

ANADIX	DIABLD	MANNESMANN TALLY
CENTRONICS	EPSON	NEC AMERICA
C. ITOH	OKIDATA	QUME
DATA PRODUCTS	QANTEX	TOSHIBA
DIGITAL EQUIP. CORP.		TEXAS INSTRUMENTS
		INTERGRAL DATA SYS.

normally friendly machines with new foulmouthed personas. In addition, the board's files had been wiped out. Security operators finally located the perpetrator—a 15-year-old.

Unauthorized computer users and their motives fall into three groups: employees (for embezzlement or vengeful destruction), hackers—high-school and college students (for malicious reasons or out of curiosity), and computer users from outside a company (committing grand theft). Alan Fielding meets what security experts consider the profile of the curious hacker turned by temptation to illegal profit.

When the law caught up with Fielding, the 21-year-old computer whiz had already illegally made a million dollars from a telephone supply company that he set up.

While studying engineering at U.C.L.A., Fielding developed intimate knowledge of telephone company technology. Referring to telephone company discards he had collected since youth, he developed a scheme

to obtain equipment from a California telephone company and resell it. He had used one telephone company's computerized ordering system to build a lucrative illegal business. He ultimately was prosecuted and convicted.

Fielding is an example of what many computer security experts fear most: the high-school hacker who turns to bigger things. Massachusetts Institute of Technology programmer Richard Stallman defines a hacker as "someone who knows computers inside and out, gets a nonprofessional amount of fun out of them, and can appreciate the irony and beauty of a program."

As applied to students, this description must also include an element of youthful and undisciplined exuberance. As Wood puts it, "Kids are often motivated by challenge or the respect of their peers. It's like joyriding in cars used to be. And, like joyriding, it's mostly a male phenomenon. Our obvious concern is, what happens when these kids grow up and mischief turns to per-

sonal gain?"

SRI's Geoffrey Goodfellow broke into his first major computer network at age 15. He calls himself a hacker—a term, he notes, that once had less derogatory connotations.

Although Goodfellow distinguishes the malicious from the mischievous or harmless hacker from the more dangerous computer criminal, security officials take a dim view of *anyone* who romps through company files. Such innocent romps, they say, sometimes cause as much damage as intentional assaults.

The Basic Tools

Fielding is just one of many who have discovered that the phone lines, a modem, and a home computer provide a computer wizard with all the burglary tools necessary to dial up and break into a computer system. From there, the possibilities are as unlimited as your imagination and skill and the information a computer system stores.

The basic tools for a computer break-in can be purchased at any

B L U E C H I P B I T S

INTRODUCING THE HOME/WORK EDITOR®

WITH COMMUNICATION INTERFACE

If you're frustrated with the limitations of your present editor, Blue Chip Software has the answer. The HOME/WORK EDITOR is a versatile text editing tool for the Apple II, Apple II+, Apple IIe and Apple Emulators with many of the features found on far more expensive text editors such as WYLBUR.

In addition to EDIT and SAVE, the HOME/WORK EDITOR'S exclusive Communication Facility allows you to SEND and

RECEIVE files by dialing up a host computer. Through phone hook-up you can communicate with most mainframes and most of the 2000 databases in North America.

\$99.95 plus applicable taxes. For more information contact your dealer or Blue Chip Software.



BLUE CHIP SOFTWARE™

P.O. Box 6635, Station C, Victoria, B.C. V8P 5N7 (604) 592-2622

Apple II, Apple II+, Apple IIe and Apple Emulator are registered trademarks of Apple Computer Company. WYLBUR is a trademark of Stanford University.

MicroScript™ \$99

State of the Art Text Formatter

- extensible generic markup
- multiline headers, footers, and footnotes
- automatic widow and orphan suppression
- automatic section numbering
- automatic bullet, number, and definition lists
- floating and inline figures
- left, center, right, or justify text alignment
- left and right indentation with delay and duration
- bold, underscore, and proportional spacing
- macros and symbols
- multiple input files of unlimited size
- direct printer control
- format preview
- IDS, Qume, Diablo, NEC, C.I.TOH, and all TTY
- table of contents, index
- multiple columns
- conditional processing

MicroEd™ \$49

Customizable Full Screen Editor

- full cursor control by character, word, or line
- position to top or bottom of window or file
- scroll by line, half window, or full window
- global or selective find and replace
- delete by character, word, line, or block
- read external files into current file
- copy, move, and write blocks of text
- insert, overlay, or wordwrap text
- all cursor addressable VDTs

Postpaid within U.S. & Canada, outside U.S. add \$5, CA residents add 6½%.
8" SS/SD CP/M-86, 5.25" SS/DD PC-DOS.

VISA

MicroType™

Master Card

6531 Crown Blvd., Suite 3A, San Jose, CA 95120
(408) 997-5026

* CP/M-86 is a trademark of Digital Research. PC-DOS is a trademark of IBM Corporation



"THE COMPUTER-LINE"

"Committed to bringing computers within the reach of all Americans"

Products for the IBM® PERSONAL COMPUTER

Hardware

Columbia Portable Computer

"The very personal computer"

Featuring:
 • IBM PC compatible
 • 128K RAM
 • 2, 5 1/4" half height drives
 • 9" green or amber screen
 • Thousands of dollars worth of free software SCALL

Also Available: HARD DISK VERSION

With Floppy and Internal
 10 Megabytes Hard Drive SCALL

IBM® Personal Computer

Features:
 • 64K Memory
 • 2 Tandon TM-100-2, 320K Byte Drives
 • 1 floppy disk controller
 • 1 color graphics card
 Slimline drives and hard disk drives configurations are available upon request.

Call for pricing
 on all IBM® Systems.

Accessories

T & G Products:
 Trak Ball \$ 45.00
 Joysticks \$ 45.00
 Gibson:
 Light Pen \$259.00

Columbia Data Products Personal Computer

Featuring:
 • IBM PC Compatibility
 • 16-Bit 8088 Processor
 • 8 Expansion Slots
 • Two RS232 Serial Ports
 • Centronics Printer Port
 • Double Density Floppy Disk Controller
 • 128K RAM Standard Memory
 • 2 320K DS/DD Disk Drives

SUPER 3000 SOFTWARE PACK INCLUDES:

Home Accountant Plus
 Perfect Writer (Word Processing)
 Perfect Speller (Spelling Checker)
 Perfect Calc (Electronic Spreadsheet)
 Perfect Filer (Data Base Manager)
 Perfect Software Customer Support Hotline
 Fast Graphs (Color Graphics Report Generator)
 Space Commanders (Color Graphics Game)
AND MUCH MORE!

Call For Pricing And Information
 On The Extensive Software
 Standard With The Computer!

QUADRAM CORPORATION

Quadboard: The memory board for the IBM featuring:
 • Fully expandable from 64K to 256K
 • Parallel Port
 • Asynchronous (RS232) Serial Port
 • Clock/Calendar
 • RAM Disk Drive SCALL

Microfazer:
 • Buffering from 8K to 64K (4-32 pages of text)
 • Printer and Computer Independent
 • Parallel/Parallel; Parallel/Serial; Serial/Serial available
 • Compute while you print! SCALL

Disk Drives

MAYNARD ELECTRONICS

Floppy Disk Controller for IBM PC
 With Parallel Port \$179.00
 With Serial Port \$209.00

SHUGART HALF HEIGHT DRIVE

Shugart Quality
 Now available for your IBM
\$235.00

SIEMANS DISK DRIVE

Double Sided/Double Density:
 320K Bytes of Storage
ONLY \$245.00

TANDON Drive Special

Double Sided/Double Density:
 320K Bytes of Storage
 TM-100-2 **ONLY \$229.00**

DAVONG HARD DRIVES:

INTERNAL or EXTERNAL
 5 Megabytes SCALL 15 Megabytes \$CAL
 10 Megabytes SCALL 20 Megabytes \$CAL

Software

ENTERTAINMENT:

Frogger
 Zork I
 Deadline
 Temple of Apshai
 Zork II
 Starcross
 Zork III

BUSINESS:

Lotus 1-2-3
 PFS: File
 The Home Accountant
 PFS: Report
 Visicalc
 Multi Plan
 Wordstar

EDUCATION:

The Most Amazing Thing
 Story Machine
 Kindercomp
 Face Maker

CALL FOR THE BEST PRICES ON
 THIS MONTHS HOTTEST SOFTWARE

Peripherals For All Computers

Printers

C.Itoh Printers:
 Prowriter I Parallel \$ 379.00
 Prowriter I Serial \$ 499.00
 Prowriter II Parallel \$ 649.00
 Prowriter II Serial \$ 699.00
Okidata:
 Microline 92: 160 CPS bidirectional with 40 CPS correspondence, 80 column \$ 499.00
 Microline 93: 160 CPS bidirectional with 40 CPS correspondence, 132 column \$ 850.00
 Pacemark 2350, 350 CPS bidirectional/2 color printing, 136 column.
 Parallel \$2099.00
 Serial \$2199.00
 Pacemark 2410.
 Parallel \$2399.00
 Serial \$2499.00
IDS Prism:
 132 Color \$1495.00
Smith Corona:
 TP-I Parallel or Serial \$ 549.00
Star Micronics:
 New Gemini 10X, improved throughout!
 120 CPS, Parallel SCALL
Juki:
 L/O, 18 CPS, Parallel SCALL

PRO/WRI TER



1550 Dot Matrix Printer

Monitors

Amdek:
 Color I \$299.00
 Color II \$499.99
 300G Green \$145.00
 300A Amber \$159.00
BMC:
 Lo Res Green \$ 89.00
 Hi Res Green \$149.00
NEC:
 1201 Green \$159.00
 1212 Color Composite \$299.00
 1203 RGB Hi-Res Color \$599.00
Zenith:
 ZVM-121 17MHZ \$109.00
Taxan:
 Amber \$145.00
Princeton Graphics:
 Outstanding color for IBM SCALL

Modems

D.C. Hayes:
 Micromodem II (Apple) \$259
 Smartmodem 300 Baud \$209
 Smartmodem 1200 Baud \$525.
 Smartmodem 1200B \$475.
 Smartcom II \$ 85
Novation:
 J-Cat RS232 Direct Connect \$119
 Smart Cat 1200 Baud \$455
 Applcat II (Apple) \$149
U.S. Robotics:
 2 year warranty
 300 Baud \$179
 1200 Baud \$479
 Password \$CA

Diskettes Library Cases

Dysan: top quality
 5 1/4" SS/DD (Box of 10) \$CA
 5 1/4" DS/DD (Box of 10) \$CA
Verbatim:
 5 1/4" SS/DD (Box of 10) \$23
 5 1/4" DS/DD (Box of 10) \$43
Elephant Diskettes:
 5 1/4" SS/DD (Box of 10) \$22
 5 1/4" DS/DD (Box of 10) \$29

Products for the APPLE® COMPUTER

Hardware

Microsci:

A-40: High reliability with 40 data storage tracks SCALL

A-70: Offers exactly twice the storage capacity of the Apple Disk II SCALL

Fourth Dimension:

With Controller Card SCALL

Without Controller Card SCALL

Hard Disk Drives:

Elite I: 40 track SCALL

Elite II: 80 track SCALL

Elite II: 160 track SCALL

DAVONG HARD DRIVES:

5, 10, 15, 20 Megabytes SCALL

Accessories

Ram Cards:

Microsoft 16K \$ 79.00

Microtek 16K Card SCALL

Davong 16K Card SCALL

CP/M for APPLE:

Microsoft Z80 Card \$269.00

Advanced Logic SCALL

80 Column Cards:

Videx with Softswitch \$279.00

Wesper Wizard 80 SCALL

Kensington System Saver \$ 69.00

T & G:

Joysticks \$ 44.00

Select-A-Port \$ 44.00

Game Paddles \$ 29.00

Kraft:

Joysticks \$ 49.00

Game Paddles \$ 33.00



NEC APC

NEC's finest business computer only available at our retail stores. Stop in and see a demonstration.

Mountain Computer:

CPS Multi-Function Card SCALL

Orange Micro:

Grappler Plus SCALL

Microbuffers:

for Epson, IDS, NEC, & Okidata

16K \$219.00

32K \$249.00

Apple IIe® Computers

- Provides these standard features:
- Typewriter-style, full ASCII keyboard, upper and lower case, and auto-repeat feature
 - 6502A microprocessor (8-bit CPU)
 - 64K bytes RAM memory
 - 16K bytes ROM, which includes built-in Apple-soft BASIC language
 - Color graphics and sound capabilities
 - Seven I/O expansion slots
 - Back panel designed for quick connect/disconnect, using D-style connectors

Franklin Ace 1000

- Offers:
- 64K Memory
 - 40 column upper/lower case display
 - Apple IIe compatibility
 - More space between expansion slots and internal fan aid cooling

CALL FOR PRICES ON FRANKLIN ACE 1200 Now Available!

WORDPROCESSING

- On Line: Screenwriter
The Professional
- Silicon Valley:**
Format II
- Southwest Data Systems:**
ASCII Express, The Professional

Software

ENTERTAINMENT:

Zaxxon
Frogger
Zork I
Choplifter
Ultima II
Deadline
Temple of Apshai
Zork II
Wizardry

BUSINESS

The Bank Street Writer
PFS: File
PFS: Report
PFS: Graph
The Home Accountant
Visicalc
Multi Plan
Wordstar
dBase II

EDUCATION:

Master Type
The Most Amazing Thing
Typing Tutor
Story Machine
Type Attack
Face Maker



HALLOWEEN SPECIALS

IBM UPDATE

	Retail	Our Price
M-100-2	\$345.00	\$235.00
M-SD-2	\$345.00	Your Choice
4K Quadboard	\$395.00	\$285.00
Verbatim DS/DD	\$ 71.50	\$ 42.50
	\$771.50	\$561.50
	SAVE \$210.00	

APPLE IIe UPDATE

	Retail	Our Price
4th Dimension	\$375.00	\$225.00
Davong 16K Ram	\$129.00	\$ 69.50
Verbatim SS/DD	\$ 49.00	\$ 24.50
	\$553.00	\$319.00
	SAVE \$234.00	

TRS-80 UPDATE

	Retail	Our Price
*TM-100-1 with case and power supply	\$249.00	\$149.00
16K Rams 8-4116	\$ 24.00	\$ 13.50
Verbatim SS/DD	\$ 49.00	\$ 24.50
	\$322.00	\$187.00
	SAVE \$135.00	



all for trade-in details

*Factory Reconditioned Warranty 90 Days

"THE COMPUTER-LINE"

Product Information & Order Lines:



California
1-800-255-4659
1-213-716-1812

Colorado
1-800-525-7877
1-303-279-2848

Customer Service & Order Inquiry: 1-213-576-6468

MS: All prices reflect a 2.9% cash discount. All goods acknowledged faulty on receipt by the customer will be repaired or replaced at our discretion. Customers must call for an RMA number before returning any goods. This facilitates our quick attendance to faulty goods. We reserve the right to repair or return to the manufacturer for repair all goods becoming faulty within the specified warranty period. Any goods (hardware or software) returned for restocking are subject to a 15% restocking fee at our discretion. The charge for cancellation of orders is 20% at our discretion. No returns on software. We accept no responsibility for any claims made by manufacturers. Prices quoted for stock on hand and subject to change without notice. Specialists in APO and International deliveries. Please add 3% (minimum \$3.00) for shipping. APO add to prices 5% for shipping (minimum \$5.00). We will calculate exact freight. Please allow a minimum of 2 weeks plus mail time (if an order is mailed in) for receipt of all UPS delivered goods. All goods (other than APO international) delivered UPS ground.

computer store or by mail. The information required for breaking in can be bought, sold, or traded on an easily accessed dial-up computerized bulletin board.

Computer security experts have identified both legitimate and "cracker" bulletin boards. The "cracker boards" are fed and manned by "T.H.E.M.," as the group is called in computer crime circles. T.H.E.M. is an acronym for Telecommunications Hackers, Embezzlers, and Manipulators. There are more than 800 of these boards operating today

in the United States, according to IACCI founder Goldstein.

The computer criminal, then, has all the needed tools: hardware to use in illegal access and, via the bulletin boards, access codes to computers across the country.

The Legal Issues

Newspaper and magazine reports have sensationalized crime committed with computers. Many articles claim that the nature of the medium makes detection of unauthorized use impossible, or that even if such use

is detected, it is impossible to prove in court. These claims are the subject of much debate.

Legislators and the courts are beginning to take computer crime very seriously. Some states, particularly those with industry bases in high technology, have passed some legislation helping to govern computer crime; indeed, bills have been proposed in the U.S. House of Representatives that may bring clarity to a multitude of complex and inter-related questions. Sentences may one day reflect the magnitude of the offense.

Unfortunately, the legal process takes time, whether at the state, local, or national level. And victims and potential victims cannot wait for those channels to yield solutions to computer-crime-related issues.

If the problem arises through technical vulnerabilities, the obvious solutions are to be found on a technical level. Technical innovations now are available that can limit vulnerability and make computer systems with dial-up access much easier to protect.

Limiting Computer Access

In the past, log-in passwords gave computer systems at least superficial protection from outside dial-up intruders. A "gray market" in these passwords, however, has weakened the protection those words once afforded. Computer gray markets, DeVries explains, operate out of underground newspapers and electronic bulletin boards, which advertise the availability of such items as telephone numbers, log-in or user names, and passwords for company computers. Such information is available in trade for similar means of access.

DeVries points out that the larger the computer system and the greater the amount of information it stores, the harder it is to supervise those using it. A system's ports of access, he says, are the weak links in a system's security.

Today new products are emerging to address the growing concern over computer security. The LeeMAH Secure Access Unit (SAU), for exam-

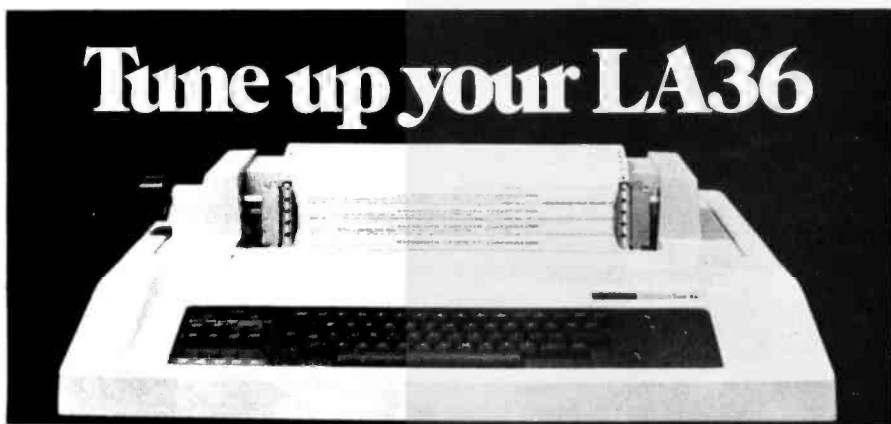

The DS120 Terminal Controller makes your LA36 perform like a DECwriter® III.

The Datasouth DS120 gives your DECwriter® II the high speed printing and versatile performance features of the DECwriter® III at only a fraction of the cost. The DS120 is a plug compatible replacement for your LA36 logic board which can be installed in minutes. Standard features include:

- 165 cps bidirectional printing
- Horizontal & Vertical Tabs
- Page Length Selection
- 110-4800 baud operation
- 1000 character print buffer
- X-on, X-off protocol
- Self Test
- RS232 interface
- 20 mA Current Loop interface
- Top of Form
- Adjustable Margins
- Double wide characters
- Parity selection
- Optional APL character set

Over 5,000 DS120 units are now being used by customers ranging from the Fortune 500 to personal computing enthusiasts. In numerous installations, entire networks of terminals have been upgraded to take advantage of today's higher speed data communications services. LSI microprocessor electronics and strict quality control ensure dependable performance for years to come. When service is required, we will respond promptly and effectively. Best of all, we can deliver immediately through our nationwide network of distributors. Just give us a call for all the details.

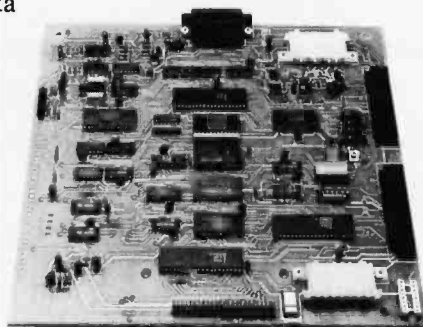

datasouth computer corporation

4216 Stuart Andrew Blvd. • Charlotte, North Carolina 28210 • 704/523-8500

The ultimate printing machines.

Perfect business partners for IBM, Apple, Osborne, Eagle and other micros.



One machine solutions to every application. Prices starting at \$698.

Meet the leading family in multi-functional micro printers. The 80-column Tally MT 160 for a small footprint; the 132-column Tally MT 180 for accounting and spreadsheet packages. (Print at 20 cpi and get 264 columns!)

A Word Processing package gives you letter quality text, proportional spacing, margin justification, auto centering. A resident Graphics package offers the versatility of two different dot densities. And you get high speed report printing at 160 cps

bi-directionally. Plus eight different resident character widths for condensed or double-wide printing.

There's more. 3-way paper handling lets you use fanfold forms, letterhead or roll stock. The control panel has a conversational program menu for easy "answer a question" push-button set-up. The dual interface has both a serial and parallel port for direct plug compatibility with your micro (no hidden interface costs!) And one look at the solid machine construction lets you

know that Tally builds printers to last!

Tally has the printers for today that you won't outgrow tomorrow.

Mannesmann Tally, 8301 S. 180th Street, Kent, Washington 98032. Phone (206) 251-5524. Mannesmann Tally Canada, 703 Petrolia Road, Downsview, Ontario M3J 2N6. Phone (416) 661-9783.

For the name of the sales outlet nearest you, call toll free **1-800-447-4700.**

(In Illinois 1-800-322-4400)

MANNESMANN TALLY

Computer printers manufactured in the U.S. and Europe for worldwide markets.

Circle 285 on inquiry card.

Protecting Information from Unauthorized Access

A variety of security techniques have emerged to combat the costly and destructive types of computer crime described in this article. The purpose of each of them is to limit access to such authorized users as employees who are traveling or working at home.

Communication with a computer from a remote terminal is usually carried out via a direct-dial telephone network. Although many online terminals are connected to the host via dedicated or private-line telephone circuits, an employee working away from his office normally accesses the company computer through the standard local and long-distance telephone network. This arrangement permits the greatest flexibility at the lowest cost.

ple, is a device designed to protect single-port systems; its recently introduced counterpart, the Secure Access Multiport (SAM), guards multiport systems. These products and others are designed to prevent unauthorized access to a system.

DeVries says that one advantage of the SAU is that it limits dial-up access to previously selected dial-up sites. Like an answering service, it screens callers before they reach the company's computer modem and log on. (See the text box on this page for details.)

Callers use a push-button telephone to send the SAU a six-digit Location-Identification Number (LIN). The device receives it, hangs up, and checks its memory for the authorized six digits.

Like an automatic electronic watchman, the SAU and the SAM answer all incoming calls to the system and provide call-back access only to those who are at authorized locations.

Within a matter of seconds, the device answers the call and receives the six-digit LIN via a push-button telephone. At this point, the device emits an acknowledgment tone and disconnects.

The device searches its call-back directory for a preprogrammed telephone number of the authorized

location. It then calls back. At the authorized site, the user answers the call, enters a one-digit connection code, and is connected to the system. If the incoming call came from an unauthorized site, the attempt to breach the security is thwarted, and, in the case of the SAM, an audit trail logs the unsuccessful attempt. Additionally, the audit trail monitors successful connections and reports on modem and line operation.

Phone-line access to company systems permits thefts of software, files, money, and materials from any distance, DeVries notes. "The tremendous proliferation of personal computers, modems, and hacking skill means that there are statistically just that many more people out there with the capability of breaking into company systems," DeVries says. "Today there are more and more people who know how to program, how to get passwords, how files and directories look, and who just might see something interesting on your system. With just passwords, someone

CREATE YOUR OWN—GAMES COMPUTERS PLAY

"This is not just another book of program listings of public domain software . . . This is a book written by an expert programmer of games, showing you how to approach game-programming through conversation and example."

Rick Horlick,
Teacher, Lincoln/Sudbury School,
Consultant, Computer Camps International

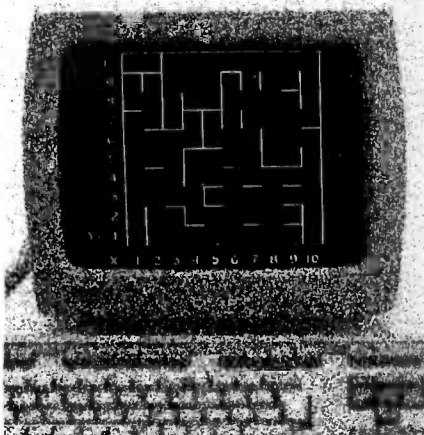

GAMES COMPUTERS PLAY, By Keith Reid-Green, gets you off to a fast start designing your own games. Want to do real-time animation? This book shows you how. GAMES COMPUTERS PLAY is full of ideas on games, graphics programs, and hobbyist applications.

Games can be written for any personal computer, in any language with this book. This book gives you all the tools you need for quick results. The author provides the basic game algorithms and shows you how to convert them to run on your system. You can enjoy designing and adding refinements. Available October, 1983, est. pages 250, includes 33 color photos and 175 drawings of actual games \$16.00, paper-bound. Order #EY-00025-DP.

Ask for GAMES COMPUTERS PLAY at your local bookseller or, order directly from Digital Press. TOLL FREE #1-800-343-8321 or 8322. In Massachusetts, (617) 663-4124, phones are open 8:00 a.m. to 4:00 p.m., Eastern time.

ORDERING INFORMATION

Return to: Digital Press Order Fulfillment
Digital Equipment Corporation
12-A Esquire Rd.,
Billerica, MA 01862

Please send me _____ copies of GAMES COMPUTERS PLAY (\$16.00). Postage and handling free when your order is prepaid by check or charge card. Ten percent discount when ordering two or more copies. Prices subject to change without notice. Make checks payable to Digital Equipment Corporation.

Check included VISA

MasterCard Purchase Order
(attach P.O.)

Charge Card Acc't No. _____

Expiration Date _____ Telephone _____

Authorized Signature _____

Name _____

Company/School _____

Address _____

City _____ State _____ Zip _____

digital

ANNOUNCING THE WY-50.

PRETTY BABY

A NEW GENERATION OF LOW-COST TERMINALS FROM WYSE.



'Never before has anyone put so much into something so good looking. Or so compact. It took revolutionary design to do it. Design a lot of people couldn't accomplish for the price. But we did.

In fact, the birth of the WY-50 introduces a new standard for low cost terminals. It was conceived to give you 30% more viewing area. Developed to meet the most advanced European ergonomic standards. And best of all, delivered for a surprisingly low price.

The WY-50 sells for only \$695.00.

BORN WITH ADVANCED FEATURES:

- 14" screen.
- 80/132 column format.
- Soft-set up mode.
- High resolution characters.
- Low-profile keyboard.
- Industry compatible.
- Only \$695.00.

For more information on the revolutionary design, outstanding features and unique good looks of our Pretty Baby, contact WYSE TECHNOLOGY

and we'll send you a brochure filled with everything you need to know.

The WY-50. It's a real beauty.

Circle 515 on inquiry card.

WYSE *Make the Wyse Decision.*

WYSE TECHNOLOGY, 3040 N. First St., San Jose, CA 95134, 408/946-3075, TLX 910-338-2251, in the east, call 516/293-5563, call toll-free, 800/538-8157, ext. 932, in CA 800/672-3470, ext. 932, in the midwest, 313/227-5011, in So. CA, 213/340-2013.

**APPLE IIe
64K RAM CARD**
80 column x 24 lines
64K RAM
Compatible with
Apple IIe Software
\$149⁰⁰

**PARALLEL INTERFACE
EPSON TO APPLE**
New From
COEX **\$49⁹⁵** CABLE INCLUDED

**5 1/4" Floppy
DISKETTES**
All Certified—100% Guaranteed
BOX of 100... **\$149⁰⁰**
Above with
Hub Rings... **\$169.00**

**COEX 80-FT DOT MATRIX
PRINTER**

- 9x7 Dot Matrix, 80 CPS, Bi-Directional Printing
 - 2K Buffered Memory
 - 80, 96, 132 Columns, Graphics and Block Printing
 - Selectable Char Pitch, Line Spacing and Feed
- PARALLEL
COEX Interface Card to Apple... **\$49.95**
Commodore Interface Card to VIC, 64, PET... **\$79.95**



\$275⁰⁰

for **APPLE
16K RAM CARD**
Language Transparent
COEX FACTORY **\$69⁹⁵**
WARRANTY

FLOPPY DISK DRIVE
Apple IIe Compatible
with • Track Zero Micro Switch
• DOS 3.2.1 & DOS 3.3
• CP/M and PASCAL
**DESIGNED
FOR YOUR
APPLE"..... \$235⁰⁰**
Controller Card
for above..... **\$75.00**

EXTENDER CARDS
for APPLE... **\$16.95**
for I.B.M.... **\$19.95**

VISION-80® \$229⁰⁰
80x24 Video Display Card
Vista Computer Company's new Vision-80 board is a sophisticated yet easy to use video display card for the Apple™ computer.

**DO YOU HAVE
A COMMODORE?**
NEW ROM for COEX 80 & DP8480
Allows Full Graphics Compatibility
with All Commodore Computers... **\$29⁹⁵**

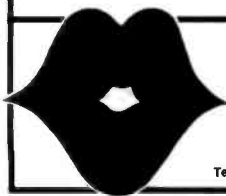

"Have You Kissed Your Computer Lately?"
Components Express, Inc.

1380 E. Edinger • Santa Ana, Calif. 92705 • 714/558-3972
TWX 910-595-1565 • ADVACON SNA • International Orders Welcome
Terms of Sale: Cash, Checks, Credit Cards, M.O., C.O.D. FOB Santa Ana. Calif. residents add 6% sales tax.



for 6809
8080, Z80
8088, 8086

Real-Time Multitasking Executive

- ROMable (< 3K)
- No royalties
- Source code included
- Language interfaces
- Low interrupt overhead
- Inter-task messages

Options:

- C, Pascal, PL/M, Fortran i/f
- Extended memory (> 64K)
- Configuration Builder Utility
- Resource (semaphore) Manager
- Buffer Manager
- Integer Math Library
- Real-Time C Library

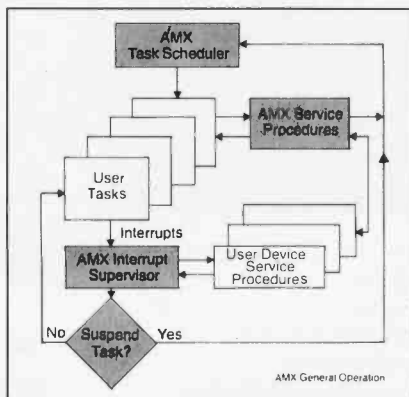

AMX, Real-Time C are TM of KADAK Products Ltd.
Z80 is TM of Zilog Corp.

KADAK Products Ltd.

206-1847 W. Broadway Avenue
Vancouver, B.C., Canada V6J 1Y5
Telephone: (604) 734-2796
Telex: 04-55670

AMX (for 8080) \$800 U.S.
manual only **\$ 75 U.S.**

in Timbuktu would have everything he needed."

"Computers are dumb and accept at face value any material put to them," Goodfellow says. For this reason, he is dissatisfied with the password system of protection. "It's too easily broken, or obtained, to provide security to something as valuable as a computer system," he explains. "People often have ridiculously obvious passwords, like their initials [or] wife's, children's, or dog's names. And if it isn't sufficiently mnemonic, they'll write it down somewhere on their desk. Obviously, for this last reason, it's impractical to assign them."

And as sensational news stories have shown, reliance upon passwords to block outsiders is foolhardy and only a partial step toward reliable security. A first step might be to remove one's computer's telephone number, thus limiting the computer's exposure to the finite number of telephone numbers in its directory.

As Goodfellow says, "What's nice about the SAU is that you know exactly who's getting in, and you can stop him at any time. You can stop employees by removing their authorization numbers from the SAU directory."

**A View from a Computer
Criminologist**

"In the 1980s," notes IACCI Executive Director Goldstein, "almost all phases of our lives have been computerized—from offices to assembly lines to farms to homes, we are increasingly in contact with computer information networks.

"We have made ourselves even more vulnerable by allowing not only our internal losses to cripple us—we have opened this door to the corporate vaults (our computer-stored data) to a dial-up criminal who can rob us from the safety and comfort of his home computer. *WarGames* of another ilk is a reality."

Goldstein added that, "One recommendation that represents a realistic appraisal of the situation is to consider a viable telecommunications device to limit or control access to the computer."

What did one computer say to the other?

Nothing much, until ASCOM came along.

With ASCOM™, personal computer communication has never been so easy. That's why Big 8 accounting firms and Fortune 500 companies use ASCOM. ASCOM is an interactive microcomputer telecommunications program for timesharing and data transfers. It is easy to use because it employs menus, simple commands and features on-line help facility.

A typical use of ASCOM is to access a data base to retrieve data for storage and analysis on your micro-computer. It can also be used to transmit program files to another machine running ASCOM or MODEM 7. This can be done locally through direct connection,

or over the telephone with a modem.

ASCOM works on IBM PC, MS-DOS, CP/M-86, CP/M-80, and TURBODOS compatible micros.



ASCOM Features:

- Works with modems or by direct connection from 110 to 19,200 baud.
- Transfers both text and program files between computers.
- Protocols synchronize large file transfers.
- Remote mode permits control of another micro running ASCOM.
- Auto processing with command files.
- Displays directories and files.

WESTICO 25 Van Zant Street
Norwalk, CT 06855
(203) 853-6880 • Telex 64-3788

Dial up our 24-Hour Computer Hotline for 300 baud modems: (203) 853-0816

Please send me an ASCOM program & documentation: \$175.00*

ASCOM documentation: \$30.00*

FREE: Catalog of over 300 programs.

C.O.D. Visa MasterCard

Card No. _____ Exp. _____

Model of Micro _____ 5 1/4" _____ 8" _____

Name _____

Company _____ Tel: _____

Address _____

City _____ St. _____ Zip _____

(*Plus \$3.00 shipping and handling in North America. CT residents add 7 1/2% sales tax). ASCOM is a trademark of Dynamic Microprocessor Associates. CP/M is a trademark of Digital Research © Copyright 1983 Westico, Inc.

WES-6.

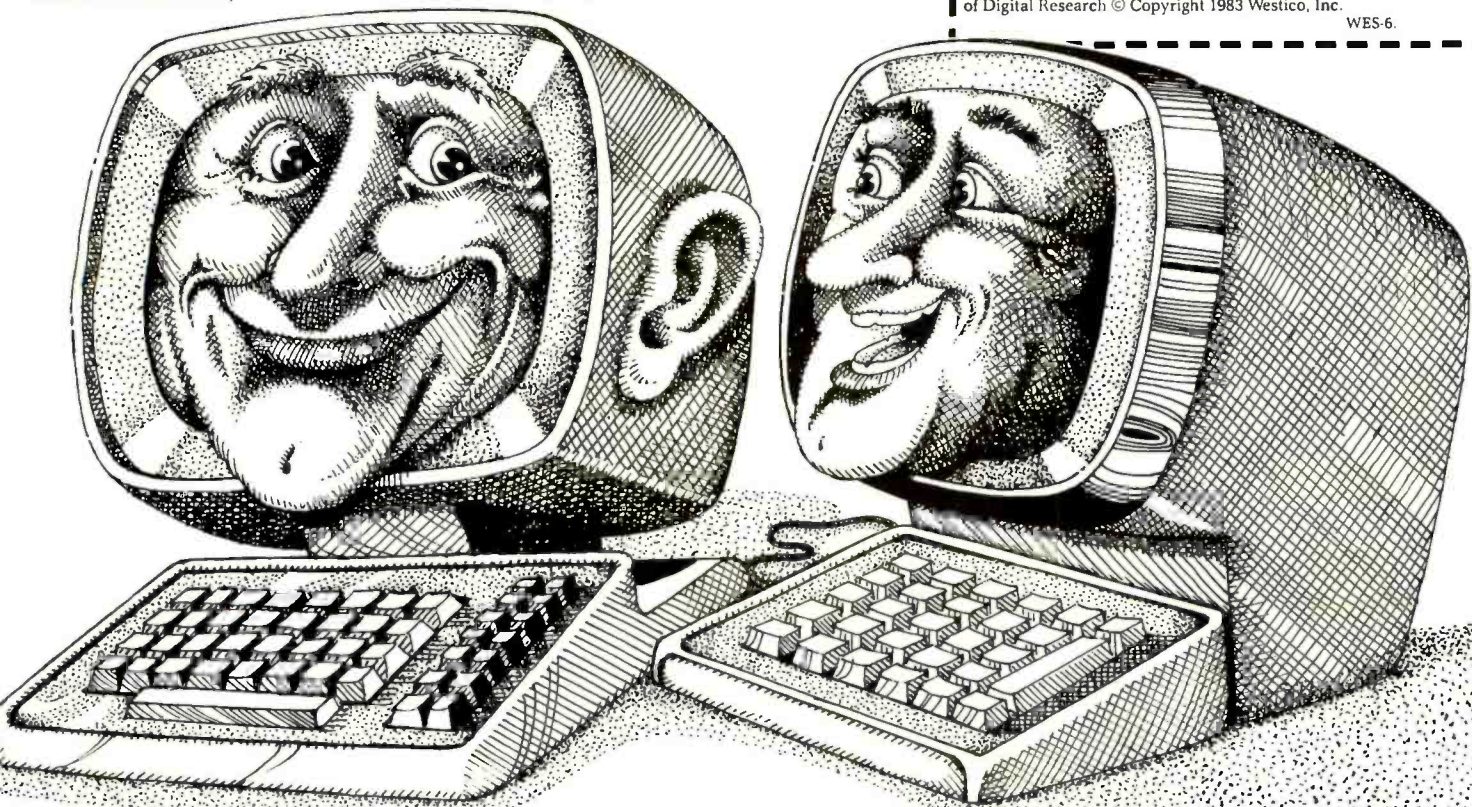

WESTICO
The Software Express Service

C. ITOH
Prowriter 8510 AP, 10" Carriage, 120 CPS, 80 col. Parallel \$379
Prowriter II, 1550P, 15" Carriage, 120 CPS, 132 col. Parallel \$645
Starwriter F-10, 40CPS, Daisywheel, Parallel \$1145
Printmaster F-10, 55 CPS, Daisywheel, Parallel . . \$1550
Starwriter F-10 Tractor . \$225

STAR
Gemini-10X, 10" 120 CPS \$325
Gemini-15, 15" 100 CPS \$465
Delta-10, 10" 160 CPS . . \$CALL
STX-80, 60 CPS, Thermal \$170

NEC SPINWRITER 3550. The new letter-quality printer for the IBM-PC. Auto proportional space. Bi-directional, 203 columns, 350 WPM, Par. . . \$1810
Tractor \$245
Cutsheet Feeder \$899
Cutsheet Guide \$95

EAGLE SOFTWARE™
 6121 Silverbriar Avenue
 Houston, Texas 77091
 (713) 692-7100

OKIDATA

ML-80P, 80 CPS, 80 col., pin & friction feed, block graphics, parallel interface \$328
ML-82A, 120 CPS, 80 col., pin & friction, block graphics, serial & parallel \$395
ML-83A, 120 CPS, 136 col., tractor & friction, parallel & serial \$689
ML-84P, 200 CPS, 136 col., 9 pin, dot addressable graphics, friction & tractor feed, parallel \$995
ML-92P, 160 CPS, 80 col., friction & tractor feed, 9 pin lead, 72 x 72 DPI dot add. graphics, parallel \$545
ML-93P, 160 CPS, 136 col., tractor & friction feed, 9 pin head, 72 x 72 DPI dot add. graphics, parallel \$875

***** RGB COLOR *****
AMOEK Color II, 13 Mi/Res \$475
Color III, 13" Lo/Res . . \$430
Color IV, 13" Hi/Res \$1050
BMC AU-919MU (680/line), 13", Made for IBM . . . \$455

**ORDERS ONLY
 TOLL FREE
 1-800-231-0616
 TEXAS RESIDENTS
 INFORMATION
 713/692-7100**

PRINCETON HX-12, 12" (690/line), Hi/Res. Made for IBM \$475
TAXAN, Vision I (380/line) 12" \$315
Vision III (680/line) 12" \$549
CABLE TAXAN to IBM or APPLE III \$19

***** GREEN SCREEN *****
AMOEK Video 300, 12" Hi/Res. Green \$145
TAXAN K6-12N, 12" Green, 800 Dot \$145
BML BM-12A, 12" Green \$89
GORILLA, 12" Green, Hi/Res \$90
USI P11, 9" Green . . . \$135
P12, 12" Green . . . \$155
SANYO, 12" Hi/Res.

***** AMBER SCREEN *****
AMOEK Video 300-A, 12" Hi/Res. Amber \$159
Video 310-A, 12" Amber Made for IBM-PC . . . \$175
TAXAN K6-12N UY, 12" AMBER 800 Dot \$150
USI P13, 12" Amber . . . \$175
P14, 9" Amber . . . \$145

TO ORDER:

5 1/4" TANDUM DRIVES
TM100-1, 5S1DD, 160K \$195
TM100-2, DS1DD, 320K \$245

APPLE COMPATIBLE
Disk Drive \$225
Controller Card . . . \$75

Hayes
Micromodem II \$258
Smartmodem 300 \$205
Smartmodem 1200 \$519

Quadram
Quadboard-64K . \$295
Quadboard-128K . \$345
Quadboard-192K . \$385
Quadboard-256K . \$445
 Each board has a parallel and serial port.
Quadram drive, Qspool, clock, 256K ability and **Quadmaster** software.

Please send money order or cashiers check. Personal or company checks require 2-3 weeks to clear. Prices reflect a 3% cash discount. Mastercard/Visa accepted. Shipping, insurance & handling charges are 3% of total order value by UPS Ground. 5% UPS Blue Label. Texas residents, no tax on Software; 5% all others. Out-of-state order, no tax. Prices subject to change. All brands are registered trademarks.

Easy Access: Curse Or Boon?
 Easy access, while a blessing to the computer user away from the office, also makes the computer vulnerable to intruders. Through the same direct-dial access port that allows a company's outside personnel to access the computer, so can a computer hacker dial in and attempt to access private and sensitive information. To prevent the loss of important data, many companies avoid direct-dial telephone access into their corporate computers. But for those companies that permit telephone access, several hardware and software devices and systems aid in preventing and detecting unauthorized usage.

Improving Security Tools

One of the simplest and oldest ways to protect a direct-dial interface port is to use an unpublished telephone number. This technique usually prevents unauthorized company personnel from dialing into the computer just to have fun. However, an unlisted telephone number is a poor security solution. Keeping a number secret and changing it as needed pose difficult problems. But perhaps the biggest drawback of using unlisted numbers is the fact that a serious attempt to discover the direct-dial-access port of a computer requires no knowledge of the telephone number itself. A smart terminal or personal computer system equipped with a simple control program and the appropriate modem and automatic dialer circuitry can be used to dial telephone numbers at random and identify those numbers that answer with the conventional modem carrier tone. This renders even an unlisted telephone number useless.

The most popular security approach in use is the password system. This software technique requires a user to enter a password to gain access to a computer's operating system. The password, like an unlisted telephone number, is kept secret and often reassigned periodically to prevent unauthorized use. And, like the unlisted telephone number, the secret password is vulnerable to random or systematic at-

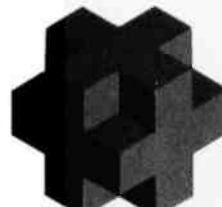

Petro-Lewis Yield Plus Fund II

A unique series of limited partnerships formed to purchase oil and gas production payments from a specified portfolio of producing

Production Payments with Initial Fixed Rate

PETROLEWIS

This announcement is neither an offer to sell nor a solicitation of an offer to buy any of these securities. The offering is made only by the Prospectus, copies of which may be obtained in any State only from dealers or brokers who may lawfully offer these securities in such State.

properties plus engage in development drilling activities on those properties.

\$450 Million Offering

Plus Development Drilling For Potential Additional Income

Minimum Subscription—\$2,500 in most states (\$2,000 for Qualified IRA Plans)

Please see that I receive the latest information on this offering, including a current prospectus.

Mail to: Kay Grover
 Petro-Lewis Securities Corporation
 P.O. Box 2250, Dept. MH-1, Denver, CO 80201

Name	Telephone
Firm	
Address	
City	State Zip

NEW FOR APPLE II AND IIe

WILDCARD™

MAKES BACK-UP COPIES OF PROTECTED SOFTWARE QUICKLY, EASILY, WITH JUST A PUSH OF A BUTTON.

New software locking schemes have rendered even the latest generation of copy programs virtually unusable. Locksmith™, Nibbles Away™ and other "Nibble copiers" require complicated parameter settings, much patience and great effort to use. More often than not, the results are disappointing. WILDCARD is different. Rather than copying disks track by track, WILDCARD ignores the disk and any copy protection encrypted on it. Instead, WILDCARD takes a snapshot of memory in your Apple® II.

Now you can make back-up copies of protected software with the push of a button.

FEATURES

- Hardware copying device... push button operation.
- Copies 48K memory resident software, most 64K software.
- No programming experience or parameters necessary.
- Backs up DOS 3.2 and DOS 3.3 disks.
- Creates DOS 3.3 unprotected and autobooting disks.
- WILDCARD lives in any slot. Undetectable by software.
- Produces autobooting disk in 2 minutes.
- Copies are DOS 3.3 compatible.
- Copies become accessible for alterations.
- Simple, easy-to-use software included.

WILDCARD *Utility Disk 1* also included, featuring:

- Automatic program compression and BRUN file maker.
- Multiple programs can be placed on the same disk.
- Recreates basic files to load and save.
- Files can be placed on a hard disk...and more.

WILDCARD \$139.95

Order direct from East Side Software Co., 344 E. 63 St., Suite 14-A, New York City 10021, 212-355-2860. Please include \$3.00 for shipping and handling. Orders outside continental U.S. please add \$10.00 for shipping and handling. Mail and phone orders may be charged to MasterCard and VISA. N.Y. State residents add sales tax. Dealer inquiries welcome.

IMPORTANT NOTICE: The WILDCARD is offered for the purpose of enabling you to make archival copies only. Under the Copyright Law you, as the owner of a copy of a computer program, are entitled to make a new copy for archival purposes only and the WILDCARD will enable you to do so. The WILDCARD is offered for no other purpose and you are not permitted to utilize it for any other use, other than that specified.

Apple and the Apple logo are registered trademarks of Apple Computer, Inc.—CP/M—trademark of Digital Research, Inc. Locksmith—trademark of Omega Microwave, Inc. Nibbles Away—trademark of Computer: applications.

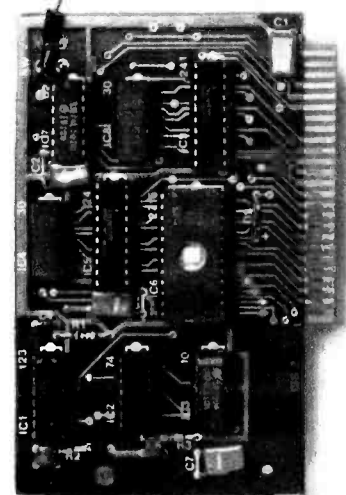

Software is not copy protected. System requirements: Apple II Plus with 64K and DOS 3.3 or Apple IIe. Franklin Ace also supported.

Wildcard does not operate with CP/M or other microprocessor based software.

Circle 166 on inquiry card.

tack using a personal computer. A dedicated hacker using an unrelenting trial-and-error technique can often uncover a valid password and unlock a company's computer software system with little or no effort. In fact, the major problem with a password approach is that users often assign very simple and easy-to-remember (and guess) passwords that often go unchanged for months and even years.

In fact, it is not uncommon for an employee to leave a company and find that the password he was assigned is still completely valid long after his departure.

Related to the password approach is a hardware solution known as the pass-through technique. With this method, after an incoming call is answered, the calling party enters an identification code, usually using the Touch-Tone telephone to enter the data. A valid code causes the pass-through circuitry to establish a full connection between the caller and the computer modem. A normal connection sequence then occurs. The

relative ease of determining a secret code and gaining entry makes this system as susceptible to failure as the password approach is.

Although these three approaches are effective for individual situations, none provides solid protection for the direct-dial computer-access port. Yet all are widely used. They should not be totally scrapped, but instead used to provide layers of security according to the requirements of the individual installations. Unpublished telephone numbers and passwords are valuable defenses even if additional security equipment and software are in place.

An Emerging Technology

Several new techniques aimed at limiting computer access are emerging. Four are data encryption, voice and fingerprint recognition, and retina scan. The first is not actually an access-control method but a message-coding technique. Voice and fingerprint recognition, on the other hand, are normally used as a user-unique "password" to control com-

puter access.

The accepted method for data encryption is the National Bureau of Standards' Data Encryption Standard (DES). This technique scrambles the transmitted data by iterative multiplication with a randomly generated 56-bit key. An additional 8 data bits in the key are provided for parity checking, thus making the DES key 64 bits long. DES keys are themselves highly secret and must be guarded as carefully as passwords.

The major drawback to data encryption is the high cost to implement even a simple system. An encrypted communications channel requires DES circuitry at both ends of a link. At the host computer, where the number of data-access ports is limited, the added cost of encryption equipment is small compared to the cost of the entire system, and the DES equipment is easily justified. Because similar equipment must also be installed at each terminal used to access the host computer, the resulting cost to modify these terminals for data encryption can easily exceed the

Your own Personal Computer



\$24.⁹⁵

in 14K Gold

First time anywhere!

Personal Computer of 14 kt gold to charm your favorite operator. Available in solid gold \$24.95. With diamonds pave' in screen \$79.95. 18" 14 kt fine chain \$22.00 additional. Also available as Tie Tack & Cufflinks. Add \$2.50 for postage and handling. Special pricing for bulk orders. To order phone 201-674-8123 or send check or money order to:

Larem, Inc. Dept. J
600 Central Ave.
East Orange, N.J. 07018



Shown
Actual Size

MASTERCARD,
VISA, AMERICAN
EXPRESS ACCEPTED

NSC 800 Real Time Emulation

Convert your existing Z 80 emulator into an NSC 800 emulator with the NSC 800/Z 80 pod.

We will be pleased to advise on a total emulation package for NSC 800 support.



KURT EICHWEBER

HAMBURG · FED. REP. OF GERMANY

Further details from Sales Representative:

International Aerospace Technologies, Inc.

Executive Plaza, Suite 110, 4717 University Drive, Huntsville, Alabama 35805. Telephone: 205/837-0611. Telex: 594441

**Purolator
armored**

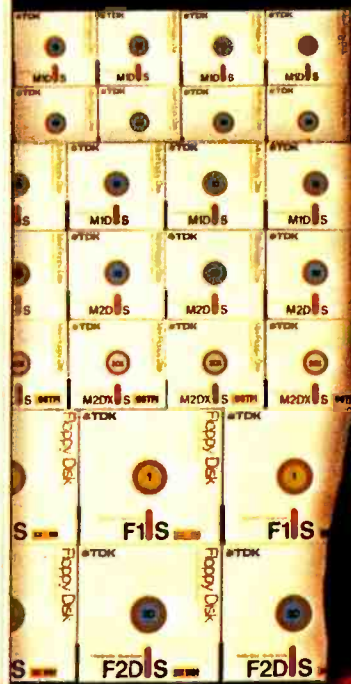

TDK Floppy Disks. Invaluable security for irreplaceable information.

Today, more and more companies are relying on convenient floppy disks to record, store and safeguard information. Irreplaceable information which is vital to their business interests. It is precisely the value placed on this information that makes the floppy disk an invaluable tool for storage and security. And this is where TDK floppy disks become invaluable to you. TDK floppy disks are guaranteed 100% error-free at the time of manufacture and certified for double-density encoding. Furthermore, each track of every TDK floppy disk is tested to exceed industry standards... including those of IBM, Shugart, ANSI, ECMA, ISO and JIS. Once you insert a quality TDK floppy disk into your computer system, you're guaranteed highly reliable, ultra smooth performance. This is due to TDK's proprietary disk-burnishing technique that provides optimum head-to-disk contact.

TDK floppy disks are available in 5¼ and 8-inch sizes in the most popular formats. Each disk comes in its own protective Tyvek-type envelope. For a copy of our brochure, "Some Straight Talk About Floppy Disks," write to: TDK Electronics Corp., Computer Products Marketing Dept., 12 Harbor Park Drive, Port Washington, NY 11050, or call 516-625-0100.



TDK[®]
The heart of your system.

terminal's initial cost by a factor of two or more. Furthermore, management of a DES key can prove difficult; a terminal with DES key codes installed is an easy target for an unauthorized user and thus provides little security. The implementation of data encryption often only shifts the data-security problem from one of controlling computer access to controlling terminal use.

Two other security techniques, voice and fingerprint recognition, are relatively new, expensive, and unproven, but they could prove useful in the future. For use in monitoring dial-access connections, voice recognition is more attractive than fingerprint verification because it does not require the use of additional hardware on remote terminal equipment. The purpose of both methods, however, is the same: to identify the user.

Tracking Attempts to Breach the System

To monitor the effectiveness of any of these security methods, a computer system should also generate an

audit trail, a record of the transactions it makes. A typical record would describe the telephone line or lines involved in each connection, the time and duration of each connection, and the access codes used to establish the connection. A log of successful and unsuccessful access attempts should also be included. This record, coupled with the call accounting records generated by most of the modern PABX and telephone-company switching systems, can be invaluable in tracing computer criminal activity.

User vs. Location Authorization

The security approaches described thus far are used to identify the user on a direct-dial access port into a computer. A second, highly accurate technique identifies the user's location rather than the actual user or his terminal. Because most legitimate users access a company computer from home or a company field office, location identification can be an important way to spot an unauthorized user.

The Secure Access Unit (SAU) provides the means to implement this technique. It verifies the location of a direct-dial access request and denies access if the call originates at an unauthorized location. This simple, low-cost hardware solution operates outside of the host computer equipment and its dial-access modems. The latter feature is important because many computer security problems stem from the unauthorized alteration of computer software or data by personnel who have access to the machine through unprotected online terminals. Once system software has been altered, the security control on outside access may be compromised.

The SAU telephone-line interface is housed in a package that's 8.5 by 11 by 2¼ inches deep (see photo 1 and figure 1). It is installed between the direct-dial telephone network and the modem on a computer-interface port; it can also be used on the remote-access port of any remotely controlled equipment and works with any conventional modem or ac-

HP 9816 Word Processor

- Screen always shows final form of document with page divisions
- Mistakes cannot cause loss of any text
- Integral spelling checker-corrector with 60,000 word dictionary
- Keyboard overlay supplied
- Header and footer, Auto page numbering
- Superscripts and subscripts
- Comment lines
- Variable indentation, right justification
- Table of contents generator
- Math functions
- Mail list and low cost options available
- Unprotected HP BASIC source code supplied
- Also available for HP 9836, 9826, 9845 & 9000

"Much easier to use than WordStar"—M.L. CA
"Very well written, congratulations"—R.E. FL
"My customers love the dictionary"—A.McD. TX

WORDWISE 2

L. W. James and Associates • 1525 East County Road 58
Fort Collins, CO 80524 • 303-484-5296

In Less Than 3 Minutes

Your IBM Model 50, 60, 65, 75, or 85
Electronic Typewriter
can be an RS232C PRINTER or TERMINAL



CALIFORNIA MICRO COMPUTER Models 5060 and 5061 can be installed easily and require NO modifications to the typewriter.

For additional information contact:

CALIFORNIA MICRO COMPUTER
17791 Jamestown Lane Huntington Beach, CA
92647 (714) 847-4141

How can your microcomputer talk to an IBM mainframe?

CLEO.



The communications features of the CLEO-3270 Software package allows your microprocessor to emulate a cluster of IBM terminal devices.

You don't even need to change software on your mainframe computer, because for all it knows, it's communicating with a 3271-12, 3275-12, or 3276-XX cluster. And the program will accommodate up to 8 terminals.

The CLEO software provides the cluster emulation and makes the ASCII devices look like an IBM 3278 CRT and 3287 printer.

If your IBM mainframe doesn't support remote 3270 clusters, you need remote batch communications. CLEO-3780 Software is your answer.

For full details contact Phone 1, Inc., 461 North Mulford Road, Rockford, IL 61107; phone (815) 397-8110.

Circle 367 on Inquiry card.

Standard Features-CLEO 3270

- Bisynchronous 3276-2 protocol to 9600 baud
- SDLC 3271-12 and 3275-12 protocol
- Up to eight line cluster activity
- Selectable control unit address
- User install program for various CRTs
- 3278 emulation for ASCII CRTs
- Available for CP/M™, MP/M™, MsDOS™, TurboDOS™, Unix™, and Xenix™.
- Coded in C language
- 3276-12 protocol, coming soon

Standard Features-CLEO 3780

- Point-to-point and multipoint communications
- Available for CP/M™, MP/M™, MsDOS™, TurboDOS™, Unix™, and Xenix™.
- Supports transparent mode
- Coded in C language

CLEO

IBM PC, APPLE, etc. . .

SHARING AND SWITCHING PROBLEMS?
GILTRONIX HAS THE SOLUTION!

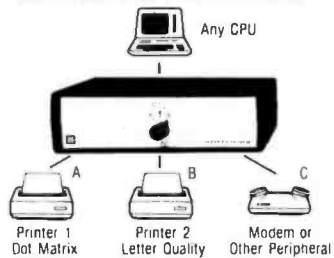

MANUAL UNITS
2-6 Ports
Selecto-Switch

OR

AUTOMATIC UNITS
2-7 Ports
Auto-Switch

Serial (RS 232C)/Parallel (Centronics)

LOW COST ADD-ONS FROM THE MAIN
MANUFACTURER



3780 Fabian Way, Palo Alto, CA 94303
(415) 493-1300

Circle 194 on inquiry card.

BASF DISKETTES

BASF Diskettes at competitive price. Call TOLL FREE (800) 235-4137 for prices and information. Visa and Master Card accepted.

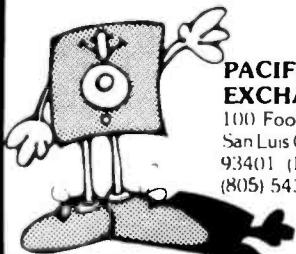

PACIFIC
EXCHANGES
100 Foothill Blvd
San Luis Obispo, CA
93401 (In Cal call
(805) 543-1037)

Circle 341 on inquiry card.



A word for this Punch/Reader Combo is

Speed! Model 510 punches paper tape at 110cps, reads at 150cps. This rugged machine is computer compatible offering RS232C, current loop, parallel inputs. The ASCII-to-Baudot code conversion permits direct keyboard entry for Telex/TWX transmission. Plus: 256 character storage, 75-9600 baud rate, 5-8 level tape, stock. ADDMASTER CORP 416 Junipero Serra Dr., San Gabriel, CA 91776 • 213/285-1121.

Circle 15 on inquiry card.

NEW! S-100 BUS COMPATIBLE

SINGLE BOARD COMPUTER WITH VIDEO OUTPUT



USES:

This card can function as a stand alone single board computer or a S-100 Intellivision video interface card

FEATURES:

4 Mbit, 2.8Kbit up to 4K of EPROM, up to 4K Static RAM, 8-bit BIT video ports, one 8 BIT output port, one 8 BIT serial input port with asterisk, composite video output (60/50), video distributors (television, underlines, blinking), graphs, capabilities.

PRICE:

Bare board with documentation \$49.95
Monitor and video terminal software (for EPROM) \$45.00
Source listing (with Monitor purchase) \$15.00
Hard to find Parts Kit (crystal and love link PROMs) \$15.00

EMS Educational
Microcomputer
Systems
P.O. BOX 10415 IRVINE, CA 92714-0415
714-553-0133

Circle 170 on inquiry card.

KEYED FILE HANDLER

FOR

UCSD "P" System
Pascal® for IBM PC®,
Apple III®, Apple IIe®

Write your own Pascal® programs with keyed records. Read a record by key, insert key and write data, get next sequential key, read a record by record number, remove key and data and release disk space, dynamic memory allocation, etc.

ATX COMPUTER

1-800-858-4620 (US)
1-800-792-1063 (TX)

Circle 428 on inquiry card.

SUPER-FAST! Z80 DISASSEMBLER \$69.95

Uses Zilog Mnemonics, allows user defined labels, strings, and data spaces. Source or listing-type output with Xref to any device. Available for Z80 CP/M or TRS-80.

SLR Systems

200 Homewood Drive
Butler, PA 16001
(412) 282-0864

Add \$2.00 shipping. Specify format required. Check, money order, VISA, Master Card, C.O.D. PA residents add 6% sales tax. Dealer Inquiries Invited. CP/M, TRS-80 TM of Digital Research, Tandy Corp.

Circle 428 on inquiry card.

cess controller that functions with voice-band data communications. Typically installed on a wall in the telephone-equipment closet next to a computer room, the unit can alternatively be rack mounted in the computer room.

The SAU contains the circuitry needed to answer all incoming calls, accept a valid Location-Identification Number (LIN), and return a call to the appropriate location before a final connection is allowed. The return call prevents general unauthorized access by positively establishing the location of the calling party before allowing access to the computer. Note that the SAU identifies the proper location of a remote user but not his identity (unless the LIN is known to only one person). In general, the SAU would be used with several security measures on a system. Passwords, software partitioning, and even data encryption could still be required to ensure complete control.

The SAU comes with a directory of return-call telephone numbers—a master number and as many as 99 authorized-location telephone numbers. Each telephone number can be as many as 16 digits long. From the master location, usually a secured telephone, the 99 other numbers can be added, deleted, or modified.

The newly introduced Secure Access Multipoint (SAM) can support 2304 users and interface as many as 64 telephone lines with one controller. Audit-trail record keeping, remote-access control of directory information, and unique line partitioning and return call routing options are also available for the multiple-line unit.

The SAU can be used to access small single-line systems and the SAM can be used for larger systems. Usually the SAU operates with one telephone line. Because it must control access into the data modem of the computer's interface port, it can function with any standard modem at any data rate. After allowing a user to access a protected computer, the unit becomes transparent during the actual data connection. The microprocessor-controlled device includes extensive self-test and maintenance

SHARP HAS DEVELOPED THE COMPUTER SYSTEM THAT LETS YOU DEVELOP THE CHIPS.

Are you a custom program developer looking for a cost-effective way to put your programs in module form?

Or an executive looking for a way to get your company's custom programs into the field?

If so, Sharp has the simplest and most direct development system available.

Introducing, the Sharp PC-1500A Computer, the CE-165 Writer and the CE-160 Memory Module.

The PC-1500A is an 8K portable computer programmable in BASIC, making it the ideal computer to take your completed programs into the field. It also serves as the input for the chip development process.

When used with the CE-165 Writer, the PC-1500A gives you the ability to write and verify your own programs into 16 8K-byte memory modules all at the same time and all in an incredibly fast 8 seconds! It also erases 16 chips in only 10 seconds!

With this kind of simplicity and speed, you can control your own delivery schedule, inventory and distribution.

And finally there's the small matter of the chip. It's another big plus for our system. The Sharp CE-160 Memory Modules are made with CMOS technology and lithium batteries that assure years of retention. They're even made with a security circuit that guards against "L-LIST" commands.

All in all, the remarkable system gives you the ability to develop your own chips while retaining control and confidentiality over your own programming.

To find out more or to learn how this system can be customized to meet your needs, call Sharp at (800) 526-0264 or (201) 265-5600. Ask for Systems Division, Vertical Marketing Group.



Sharp Electronics Corp., 10 Sharp Plaza, Paramus NJ 07652

Circle 362 on inquiry card.



FROM SHARP MINDS
COME SHARP PRODUCTS

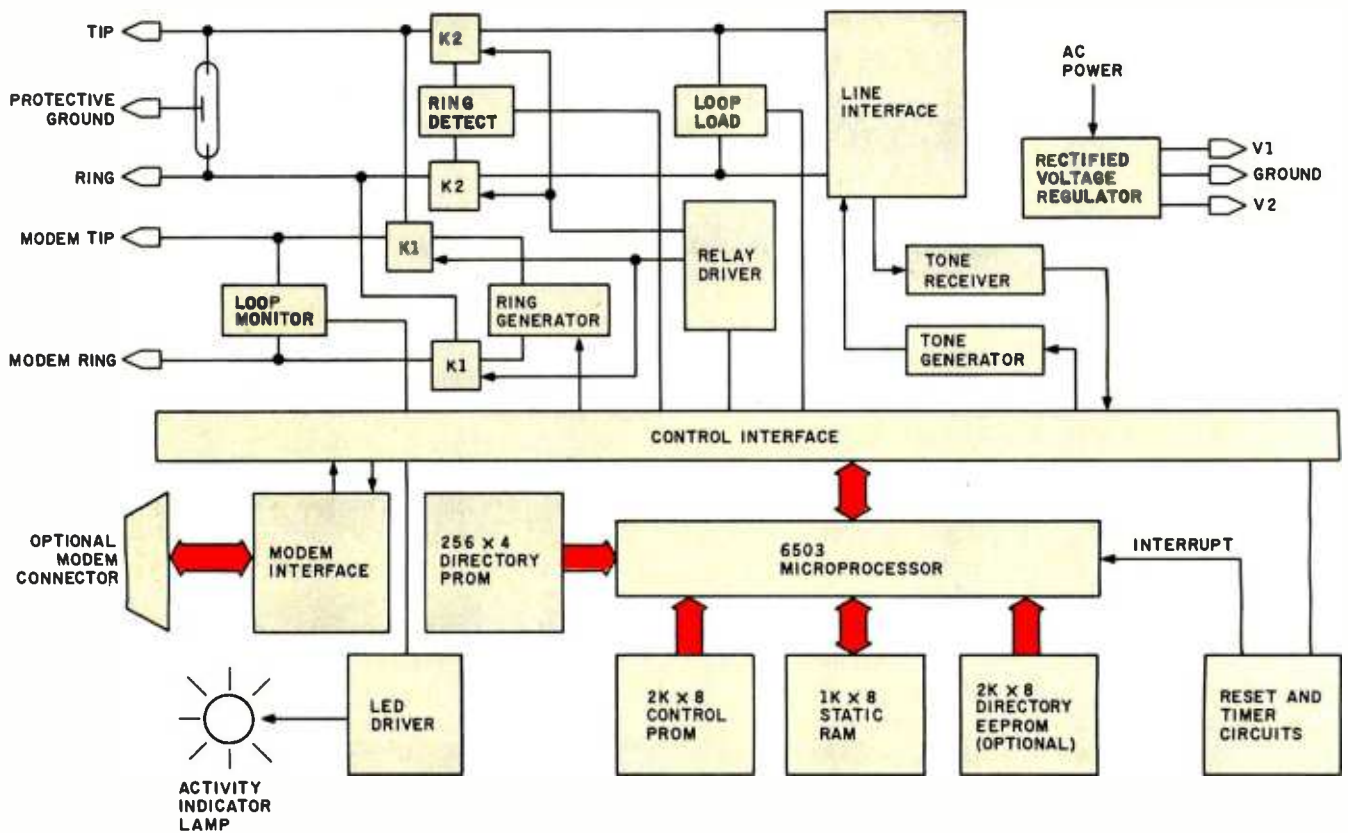

Figure 1: A block diagram of the Secure Access Unit's circuitry.

capabilities, fail-safe control of malfunctions, and remote testing features.

Figure 1 is a block diagram of the SAU's circuitry. The device normally derives power from a wall-plug low-voltage transformer. The circuit board is enclosed in a metal housing with a hinged-cover door that can be equipped with a locking latch.

The SAU interfaces the telephone line through the "TIP" and "RING" terminals. Detection of the ring current is accomplished with the block marked Ring Detect, an optoisolator coupler detection circuit that provides high isolation between the telephone line and the SAU's control circuits. The 6503-based main controller analyzes the ring signal information and answers the incoming call by operating relay K2. Next, a DC loop load circuit block and an AC line interface block are connected to the TIP and RING terminals. The SAU is then prepared to receive the LIN as a tone code from the calling party.

After the SAU receives the LIN, a sequence of six digits, it checks the code against a table of telephone

numbers stored in its directory. If a match is found, it uses the tone generator to send the user an acknowledgment tone and then monitors the DC loop conditions for the proper network disconnect signal to ensure that the user has properly hung up the telephone handset. If this network signal does not occur at the appropriate time, the SAU begins a forced disconnect procedure.

The SAU also terminates incoming telephone calls that do not result in a valid LIN code within a preset time period. This function prevents a caller from hanging on the line to tie up the device and the computer port it protects.

As depicted in the operational flowchart in figure 2, the SAU continues its security function by returning to an off-hook state and dialing the telephone number that corresponds to the valid LIN it received. After the user answers this return call and enters a one- or two-digit connection code, the SAU activates its associated modem and relay K1 to connect the user through to the host computer's modem. The SAU monitors the con-

nection first through the normal line-interface circuit block to ensure a proper modem handshake sequence has occurred and then through the high-impedance loop-monitor circuit block to detect the completion of the call. When this call is complete, the SAU returns to its idle state, ready to receive the next call.

The SAU can interface the host computer modem in one of two ways. Because normal direct-dial interface ports are arranged with automatic answer modems, the SAU's primary interface arrangement is through the ring-generator circuit block; the unit is wired to the modem through the two terminals marked MODEM TIP and MODEM RING. When the SAU is ready to activate the modem, it synthesizes a high-voltage 20-Hz ring signal that it transmits to the idle modem. The modem, interpreting this signal as an incoming call, connects to the MODEM TIP and MODEM RING lines to answer the call. The SAU then operates the K1 relay and connects the modem to the normal TIP and RING telephone lines.

Sleeves of Tyvek® protect your data investment better than paper. Here's why:



1. TYVEK® spunbonded olefin has more than twice the strength of good quality paper.
2. TYVEK does not lint.
3. TYVEK is smooth and nonabrasive.
4. TYVEK is chemically clean... has a neutral pH.
5. TYVEK reduces static problems.
6. TYVEK is unaffected by water.

With TYVEK, you don't have to compromise on any important sleeve criteria. You get it all. That's why TYVEK is still the best way to protect your diskettes.

For more information, write: DuPont Company, Room X40133, Wilmington, DE 19898.

®DuPont registered trademark.
DuPont makes TYVEK, not sleeves.



Circle 160 on inquiry card.

(800) 272-3360
TOLL FREE IN CALIFORNIA

(800) 292-3360
TOLL FREE OUTSIDE CALIF.

**"WHY PAY MORE"
COMPARE THESE PRICES
MC-P APPLICATIONS
BRINGS SOFTWARE & HARDWARE
AT UNBEATABLE PRICES**

SOFTWARE

	LIST	OUR
APPLIED SOFTWARE TECHNOLOGY		
VersaForm	\$389	\$252
ASHTON TATE		
Financial Planner	700	452
BPI ACCOUNTING SYSTEMS		
GL/AP/AR (Each)	395	285
FOX & GELER Quick Code .. 295 184		
HOWARD SOFT		
Real Estate Analyzer II.....	195	126
LIFETREE Volkswriter		
	195	129
MICROSTUFF Crosstalk		
	195	125
MICROPRO		
Word Star w/Applicard	495	345
MICROSOFT		
Flight Simulator	50	33
PBL CORPORATION		
Personal Investor	145	94
PEACHTREE		
Peach Pack (AR, AP, GL) ..	595	300
SOFTWARE PUBLISHING		
Pfs: File		
Apple	125	81
IBM	140	91
Pfs: Report	125	81
SORCIM SuperCalc		
	195	130
SNAPSE File Manager		
	150	97
VISICORP		
Visicalc	250	165
Visifile (Apple)	250	165
Visifile (IBM)	300	198
VisiSchedule	300	198

LOTUS 1-2-3
\$325⁰⁰

WORD STAR PRO
\$435⁰⁰

DBASE II
\$395⁰⁰

EDIX/WORDIX
\$129⁰⁰

MULTIPLAN
\$168⁰⁰

HOME ACCOUNTANT
\$ 49⁰⁰

BANK STREET WRITER
\$ 46⁰⁰

TANDON T100-2
\$235⁰⁰

OKIDATA 92
\$499⁰⁰

AMDEX COLOR II
HI RES RGB
\$425⁰⁰

AST MEGA PLUS 64K
\$320⁰⁰

NOVATION J-CAT
\$105⁰⁰

EPSON FX 100
\$635⁰⁰

HERCULES GRAPHICS CD.
\$359⁰⁰

USI MULTI DISPLAY CARD
\$339⁰⁰

HARDWARE

	LIST	OUR
HAYES MICROCOMPUTER PRODUCTS		
Hayes Stack Chronograph (RS-232)	\$249	182
Hayes Stack Smart Modem (RS-232)	289	214
Smart Modem 1200 (RS-232)	699	505
ADVANCED LOGIC SYSTEM (Apple II)		
Z-Card	169	110
Printer Mate (Parallel)	99	49
CP/M Card (W/ CP/M 3.0) ..	399	300
MICROSOFT		
Softcard (Apple)	345	242
Ram Card (Apple)	100	70
64K Ram Card (IBM)	350	245
MPC PERIPHERALS (Apple)		
Parallel Interface Card (w/Cable)	90	63
NOVATION		
Apple - Cat II	389	260
212 Auto Cat	695	561
Smart-Cat 103/121	595	416
Smart-Cat 103	249	174
PERSONAL COMPUTER PRODUCTS		
Applicard 6 Mhz	375	265
Applicac: 4 Mhz Applicard & Max 80 Col Card	620	334
KRAFT Joystick		
IBM	70	46
Apple	65	42
VERBATIM DISC		
S/S D/D 10 Pk.	49	24
AMDEK MAI BOARD		
	599	455
ELECTRONICS PROTECTION DEVICES		
Lemon	60	39
Peach	98	63
QUADRAM		
Quadboard 64K	395	285
Quadboard 512 + 64K	325	240
MEMORY CHIP SET (64K/9 chips)		
	95	55
PRINTERS		
Mennesman Tally MT 160L ..	798	635
NEC 8023A		395
MONITORS		
Amdek 12" 310A	230	169
Panasonic CT 160 Color	399	305
Princeton Graphics		485

CALL FOR OTHER SOFTWARE & HARDWARE PRICES
"International Dealer Enquiries Welcomed"

MC-P APPLICATIONS

111 W. St. John St., Suite 307

San Jose, CA 95113 Phone (408) 293-3360

Telex: 294207 MCPA UR

HOURS: 8 a.m. to 5:30 p.m. — Mon. - Sat.

(Phone Orders Only on Sat.)

TERMS: All prices subject to change. Cashier's check/MO/Bank Transfer. Allow time for company or personal checks to clear. Prices reflect cash prepaid discount. VISA/MASTER CARD/COD/PO's =3%. California residents add sales tax. **SHIPPING:** \$2 per item for UPS surface (\$6 for Blue Label) within continental USA.

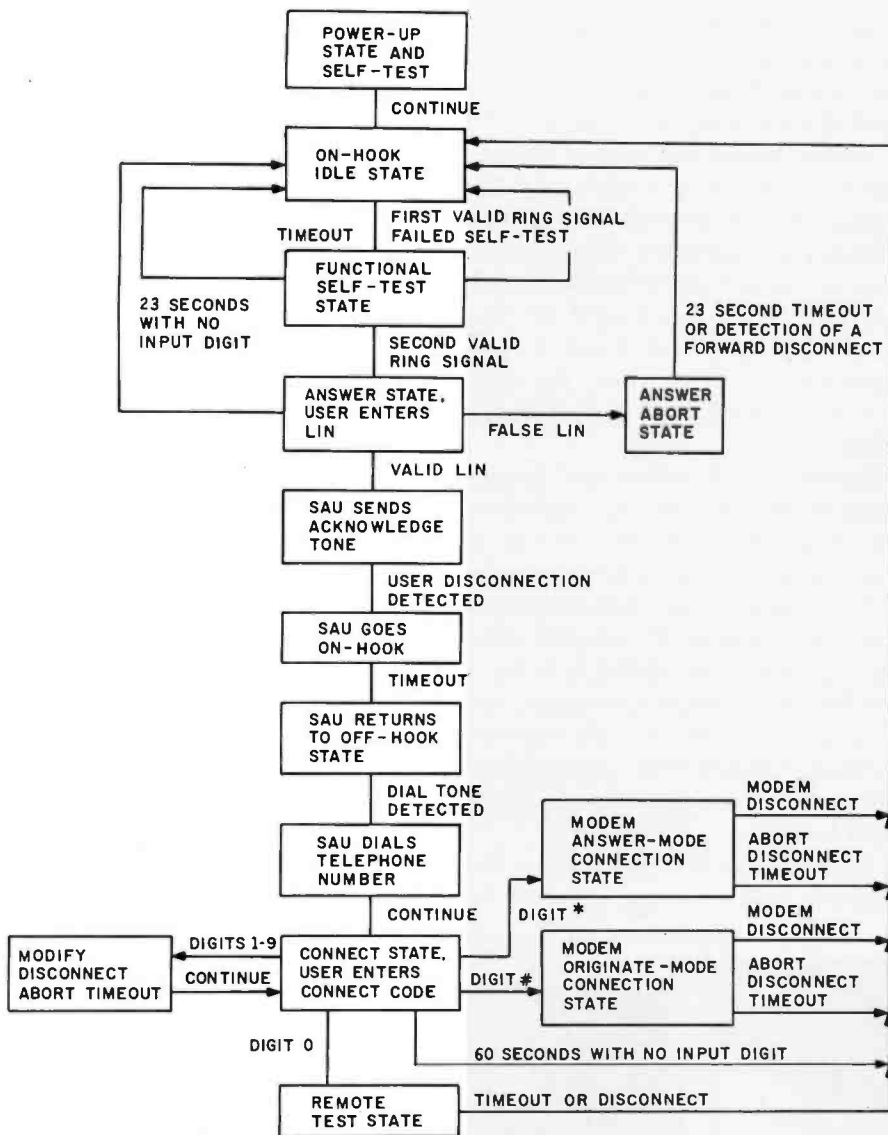

Figure 2: This flowchart describes the Secure Access Unit's (SAU) operation. Note that if the unit receives an invalid (false) Location-Identification Number (LIN), it aborts the attempt to access the host computer and returns to the idle state.

An auxiliary connector (marked in figure 1 as the optional modem connector) and the modem-interface circuit block provide additional control leads and functions to activate an originate-mode modem. In this interfacing scheme, the SAU connects the MODEM TIP and MODEM RING lines to the telephone lines while it operates a control lead to the modem. The modem is forced into the connection state—originate mode—and listens for the normal answer-tone carrier signal from the user's modem. After the connection is established, the SAU resumes its line-monitoring functions.

Several control and dialing features

are provided in the SAU's software. For installations with full automatic modem equipment at both ends of the connection, the SAU can function without the need for a connection code from the user after the return-call operation is complete. Also, the device can be requested to dial out one of ten 16-digit prefix numbers before dialing a regular number from its return-call directory. This system has two advantages: it allows telephone numbers as long as 30 digits to be dialed, and the prefix numbers need only be entered into the directory once.

The SAU performs several self-tests before it answers an incoming call.

The best of UNIX™ and more for CP/M™ CLIP/\$4995

No risk, 15 day, money back guarantee*

CLIP runs as a standard CP/M 2.2 program replacing the console command processor with a powerful UNIX-like shell. CLIP, optimized for the Z80, takes only 5.2K of additional memory when running your applications programs.

- **Over 50 resident commands**

- **Editing keys**

Single keystroke commands allow you to edit and recall your last 10 commands—just like a word processor! These editing keys may be used within most existing programs, too.

- **UNIX-like enhancements**

CLIP brings the most powerful UNIX features, namely, I/O redirection and pipes, to CP/M.

- **Design your own commands**

CLIP is also a powerful "macro" programming language replacing SUBMIT with:

- Conditional command execution
- Argument and switch parsing
- Command tracing
- File I/O (OPEN, GET, PUT, CLOSE)
- Extensive string manipulations

- **Built-in calculator**

This binary, octal, decimal, and hex calculator can pass its results to programs, macros, or 10 memories.

- **Built-in universal text editor**

- **And much more!**

On-line HELP, file searching, user defined prompt, and multiple commands per line.

Software Tools Package \$25

A set of fourteen software tools, inspired by UNIX, complement and enhance CLIP. These tools contain: a sorter, binary file editor, resynchronizing file comparer, pattern matcher, word extractor, and more!

File Encryptor \$25

This program will keep letters, data, programs, or any CP/M file secure.

CLIP, Tools and Encryptor \$9995

Experience more productivity and control of CP/M today! With our money back guarantee, you have nothing to lose!

Visa/MC/Check/MO/PO accepted

Add \$3.50 shipping, AZ: 7% tax

Formats: 8"SSSD/Osborne/Kaypro/Apple/Heathkit/Northstar/VT180+Rainbow/Xerox 820/Micro Decision/Superbrain/NEC-8001

*10% restocking fee

Thoughtware, Inc.

800-821-6010 602-327-4305

Orders

Technical

P.O. Box 41436

Tucson, AZ 85717

These include functional verification of the tone generator and receiver, tests of the telephone line loop voltage and impedance, tests of the connection veracity between SAU and the modem, and verification that the proper connection arrangement exists between the SAU and the telephone line. Should a test fail, the unit does not answer calls, thus guaranteeing that no malfunctions occur during the critical return-call operation.

In addition to performing self-tests, the SAU can be placed in a remote-test operating mode. Remote testing allows a reading of the directory serial number (not its contents), measurement of tone levels and frequencies from the tone generator, correct operation of the tone receiver, and verification of the connection wiring to the companion modem. As are all the SAU's operations, the remote-test state is protected by the return-call sequence to prevent unauthorized remote-controlled tampering of the unit.

The SAU/SAM return-call security technique, like almost any computer-security method, increases the time needed for access-port connection. In a normal automatic-answer direct-dial modem setup, it adds approximately 15 to 45 seconds to the time required to establish a data connection—the time it takes the user to dial the LIN and that required for the return-call operation. Once a data connection is established, the unit does not delay the actual data transmission.

Password and voice- and fingerprint-recognition security schemes take less overall time than the unit; the data-encryption approach probably increases the call duration, though, because it reduces data throughput. Time added to make a connection can be an annoyance, but it's a minor inconvenience compared to those resulting from unauthorized entry into a corporate computer's data banks.

Similar to the SAU technique is the manual call-screening process in

which an operator (instead of the SAU) verifies each incoming call by returning a call to a prearranged telephone number. Unless the calling party has wiretapped the telephone line or broken into the location of the authorized telephone number and guessed the correct LIN, this return-call operation is very effective at establishing a legitimate connection. Such techniques as encryption, passwords, or pass-through connections cannot provide a similar level of security at a comparable cost.

Remember, however, that the SAU/SAM does not provide the total solution for every situation. Layers of security control are crucial and should be carefully considered before a total direct-dial-access security package is chosen. ■

Collen Gillard holds a master's degree in communications from Stanford University and writes frequently on computer-related subjects. Jim Smith is a partner in Omnicom Engineering, a design firm that developed the LeeMAH Security Access products.

EXPORTING SERVICES

Overseas dealers and distributors:
You need the lowest prices prompt
delivery, exclusive territories and
professional services. We've pro-
vided these for three years. We've
access to over 500 U.S. hardware
and software manufacturers. Telex
us NOW for more information or a
quotation.

**American Buying and
Exporting Services**
1635 School St.
Moraga, CA 94556
(415) 376-7600
Telex: 470851



**Active
Electronics**

**NUMBER ONE IN
QUALITY
SERVICE
AVAILABILITY**

**THE WORLD'S MOST
COMPLETE PROFESSIONAL
AND HOME ELECTRONICS
ENTHUSIAST INVENTORY**

- Semiconductors + Memories
- Microprocessors + Support Circuits
- Microcomputer Systems + Peripherals
- Passive Electronic Components
- Hand Tools, Wire Wrapping,
Soldering Equipment + Hardware

**NOW AVAILABLE — FREE
1983 80-page catalog**

A complete listing of products
and specifications

Call, write or circle the
inquiry card for your
free copy today.

**P.O. Box 8000, Westboro, Mass. 01581
CALL TOLL FREE: 1-800-343-0874**

Mass customers call (617) 366-0500

Softline

FOR YOUR BOTTOM LINE.

ALPHA SOFTWARE		HUMANSOFT		OASIS	
Data Base Manager II	\$169	DBplus	\$ 89	The Word Plus	\$119
Apple IBM Connection	\$139				
ART SCI		IUS		ORGANIC	
Magic Window II	\$109	EasyWriter II	\$229	Dalebook II	\$239
Magic Calc	\$109	EasySpeller II	\$149	Milestone	\$239
Magic Memory	\$ 74	Financial Management Series	\$939		
ASHTON-TATE		INNOVATIVE SOFTWARE		PBL	
Friday	\$199	TIM III	\$299	Personal Investor	\$149
Bottom Line Strategist	\$279	Fast Graphs	\$169		
Financial Planner	\$459			PEACHTREE	
APPLIED SOFTWARE TECHNOLOGY		INSOFT		Peachtext (for Apple II)	\$159
VersaForm	\$249	Data Design	\$169	Peachpak—GL/AP/AR	\$269
Q base	\$145				
BPS		ISM		PERFECT SOFTWARE	
BPS Business Graphics	\$279	Mathemagic/Graphmagic Combo	\$119	Perfect Writer	\$239
COMPREHENSIVE SOFTWARE				Perfect Speller	\$149
PC Tutor/PC Pal Combo	\$ 79	LJK		Perfect Calc	\$149
		Data Perfect	\$ 89	Perfect Filer	\$289
Condor Computer		Letter Perfect	\$109		
Condor III	\$439			PETER NORTON	
CONTINENTAL SOFTWARE		LEXISOFT		Norton Utilities	\$ 59
Home Accountant Plus	\$ 99	Spellbinder	\$249		
Home Accountant (for Apple II)	\$ 49			ROSESOFT	
FCM (for Apple II)	\$ 85	LIFETREE		ProKey	\$ 59
FCM (for IBM PC)	\$ 69	Volkswriter	\$129		
DATAMOST		MARK OF THE UNICORN		SIERRA ON LINE	
Write On	\$ 89	Final Word	\$199	Screenwriter Professional	\$149
REIP (Real Estate)	\$129			The General Manager	\$169
DIGITAL RESEARCH		MICRO PRO		SILICON VALLEY SYSTEMS	
CP/M 86	\$ 50	WordStar	\$289	List Handler	\$ 69
Concurrent CP/M 86	\$259	SpellStar	\$159	Word Handler	\$339
EAGLE SOFTWARE		MailMerge	\$159		
Money Decisions	\$129	WordStar Professional (WS/MM/SS)	\$549	SOFTWARE ARTS	
EMERGING TECHNOLOGY		WordStar with Applicard	\$389	TK! Solver	\$219
Offix	\$ 79	MICROSOFT		SOFTWARE PUBLISHING	
Edix/Wordix	\$279	Multitool—Financial Statement	\$ 79	PFS: Write	\$ 99
FOX AND GELLER		Multitool—Budget	\$119	PFS: File	\$ 99
Quickcode	\$184	MICROSTUF		PFS: Report	\$ 89
HAYDEN SOFTWARE		Crosstalk	\$129	PFS: Graph	\$ 99
Pie Writer (for Apple II)	\$109	MUSE		SOFTWARE TECHNOLOGY FOR COMPUTERS	
Pie Writer (for IBM PC)	\$139	Super Text Professional	\$ 79	The Creator	\$219
HOWARD SOFTWARE		NORTH AMERICAN BUSINESS		SORCIM	
Real Estate Analyzer	\$185	Memory Shift	\$ 79	SuperCalc	\$129
Tax Preparer 83	\$185	Answer	\$189	SuperWriter	\$179
				SpellGuard	\$129
				VISICORP	
				VisiCalc	\$169
				VisiSchedule	\$219
				VisiTrend/Plot	\$219

dBase II \$399	1-2-3 \$339
WordStar MailMerge \$359	Multiplan \$189
PFS: File PFS: Report \$189	VisiCalc-Advanced \$299
PeachText 5000 \$249	MultiMate \$299
VisiWord \$279	VisiFile \$219 for IBM PC
DB Master \$159 for Apple II	SuperCalc 2 \$179

For more information on our complete line of software and accessories call our toll-free number for a FREE copy of The Softline Catalog

FREE!

Diskette Library Case

... with your order. This attractive case protects, indexes and stores 10 diskettes for quick retrieval. Normally a \$10 value, it is now available **FREE** to Softline customers



TERMS:
Checks—allow 14 days to clear. Visa and MasterCard—add 3%. COD orders—cash, m.o. or certified check—add \$3.00. Shipping and handling UPS surface—add \$3.00 per item (UPS Blue \$6.00 per item). NY State Residents—add 8.25%. All prices subject to change.

To Order call
1-800-221-1260
In New York State call (212) 438-6057

For technical support
and information call
(212) 438-6057

Monday
thru Friday
9:00 AM - 7:00 PM

Sundays
10:00 AM - 4:00 PM

Softline
Softline Corporation
1333 60th Street, Brooklyn, N.Y. 11219



Circle 547 on inquiry card.

For IBM-PC and New, easier-to-use programs And you won't have to

If you're like most personal computer users, you're not using your computer as much as you expected to.

You find the software too complicated.

Too much to read.

Too much to remember.

Too much new software being offered. And too difficult to find out what works best.

Help Is On The Way.

Software Digest is a unique new monthly service that will make your life simpler. And help you get more out of your computer. By making software easier to use. And easier to compare.

We'll digest programs for you.

Every month you'll get a valuable new program to simplify a specific task. On disk. Ready to run.

Plus brief demonstrations of more comprehensive programs in that same category. Also on disk.

We'll digest information for you.

Every month you'll get a concise buyer's guide with clear comparisons of all major programs of that type.

We'll digest opinions for you.

Every month you'll get the results of an up-to-date survey showing how a large number of actual users, as well as reviewers, rate each program for ease, performance and reliability.

Sharp Focus and Brevity To Save Your Time.

We'll focus sharply on one important application every month.

The first month, we'll cover word processing, including spelling programs. The next month, personal record keeping. Spreadsheets, investment analysis and other categories will follow.

We'll eliminate the technical jargon. Cut out excess wordage. Boil things down to essentials. And organize the facts to make them more useful.

Everything will be in plain English. And there is a separate edition for your system. So you won't have to wade through information for other computers. What you get from us, you can use.

A Sweetheart of a Disk.

The heart of Software Digest is its monthly disk—you'll get a different one each month.

We'll pay substantial royalties for streamlined versions of valuable programs that meet our standards of simplicity and reliability.

You'll get these programs as part of our service. At no additional charge.

And we'll make them so simple that you can run them immediately. Without a manual.

Each disk will also contain demonstrations of other programs in the same category from leading software houses. You'll be able to try out these programs in your own office or home. At your convenience. Without any pressure.

There will also be several additional features on each monthly disk. Utility programs that will grow into a valuable program library. A serialized "computer literacy" course to help you really master your computer. And—for a little diversion—a game every month.

All on a disk. Ready to run.

Why You Will Like Our Programs.

Let's consider the first program you'll get from us. The Software Digest Letter Writer.

Most word processing programs try to outdo each other with a multitude of functions.

But you need a word processing program primarily for writing letters or memos.

And you'd like it to be simple.

So we're going to give you the kind of program you'll really like to have, but haven't



Apple users. at a surprisingly low cost. read any manuals.

been able to find. An extremely simple word processing program—*with a minimum of commands and instructions*—to make it easier to handle your business and personal correspondence.

If you already have a more complex word processing program, you can save it for those less frequent occasions when you have to write a multi-page report, or a book.

If you don't have such a comprehensive program, but need one, Software Digest will help you make an intelligent selection.

Subscribe Now and Save 40%.

Individual issues of Software Digest will be available at computer and book stores, later this year, at the single issue price of \$25.

But you can save 40% by subscribing in advance. *The cost to subscribers will be only \$15 per issue—including the monthly disk.* A tremendous bargain.

You'll be billed for only one issue at a time. *after* it is mailed to you, not before.

Another advantage of becoming a subscriber is that *you'll have 10 days to examine each issue and actually try out the programs.* If you're not fully satisfied, just send it back. The charge and your subscription will then be automatically cancelled.

Subscribe today, while this special offer is in effect. You'll save money. And you'll be able to build a *complete* collection of Software Digest programs and guides—beginning with the important first issue.

Software Digest[™]

P. O. Box 10 Merion, PA 19066

Software Digest is a trademark of Software Digest Inc.; IBM-PC, Apple and Franklin are trademarks of IBM Corp., Apple Computer Inc. and Franklin Computer Corp.

CREDIT CARD HOLDERS MAY ORDER TOLL-FREE:

IBM-PC Edition . . . 1-800-345-8500—Ext. 400

Apple Edition 1-800-345-8500—Ext. 401

RISK-FREE CHARTER SUBSCRIPTION APPLICATION

Software Digest
P.O. Box 10
Merion, PA 19066

Please enter my subscription to Software Digest, beginning with the first issue, at the special subscriber's price of \$15 per month. Bill me or charge my credit card account **after** each issue is mailed. I have the right to cancel at any time. I also have the right to return any issue within 10 days after receipt, in which case both the charge for that issue and my subscription will be automatically cancelled.

PLEASE TYPE OR PRINT VERY CLEARLY. THANK YOU.

Name _____

Company (if applicable) _____

Address _____

City, State, Zip _____

Bill me. Bill my company (Purchase Order No. _____)

Charge to my: Master Card Visa American Express

Card No. _____

Exp. Date _____ Signature _____

IMPORTANT - SPECIFY YOUR COMPUTER MODEL BELOW

Minimum of 64K memory (48K for Apple models) and one 5¼" disk drive required. If you don't have enough memory or a disk drive, your computer dealer can easily add it to your system.

- IBM-PC or other computer that runs IBM-PC software.
 Apple, Franklin or other computer that runs Apple software.

If you are interested in receiving Software Digest for another make of computer, please indicate your model and operating system below. We will inform you when Software Digest begins an edition for that system:

T

More Unix-Style Software Tools for CP/M

The CP/M Microtools include the most popular utilities available for the Unix operating system

by Christopher O. Kern

Microtools, a package of Unix-style utilities for the CP/M environment, testifies to the popularity of the Unix operating system and its utilities. The 26 programs in this package can be used with regular CP/M or with CP/M enhanced by Microshell, a command interpreter similar to the Unix Shell. Microshell replaces the stan-

dard console command processor (CCP) of CP/M and creates a Unix-like framework within which the Microtools programs run. Both Microtools and Microshell are distributed by the same company, hence it's not surprising that they work together.

The Microtools package is similar, in many respects, to another set of Unix-style software tools, called Unica, which I reviewed in a previous issue (see "Microshell and Unica: Unix-Style Enhancements for CP/M," December 1982 BYTE, page 206). There is some overlap between Microtools and Unica. For example, both products include pattern-matching programs modeled after the Unix grep family of utilities and both offer file-comparison programs based on the diff utility that is available on Unix systems (see listing 1).

The two products are guided by the same philosophy of small, general-purpose programs, as well. Both, for instance, provide a consistent command syntax. Options and parameters for the programs are specified in a similar manner for all the programs in each package.

The programs in each package are also designed to work together. Using temporary files, they can be combined in "pipelines" that read the output of one program into the input of the next program, as shown in listing 2c. Both packages feed the output from one program to a temporary file, from which the next program reads its input. That means that the time required to execute a pipeline is equal to at least the sum of the times required to run the programs individually. Unica is also capable of these composite functions.

Under Unix, which is a multiuser, multitasking operating system, the programs in a pipeline execute simultaneously. The system provides coordination and transfers data between them.

There are some important differences between Microtools and Unica, however. The Microtools programs are all designed to be compatible with the Microshell com-

At a Glance

Name

Microtools

Type

Unix-style utilities for CP/M

Author

Donald Graft
Microtool Software
POB 12
Naperville, IL 60566

Distributor

New Generation Systems Inc.
2153 Golf Course Dr.
Reston, VA 22091
(703) 476-9143

Price

\$150

Format

Various CP/M floppy-disk formats

Computer

8080/8085/Z80-based computers with the CP/M-80 operating system

Documentation

73-page users manual

Audience

Business users and hobbyists who want the utilities available on Unix

Listing 1: A comparison of the Microtools and Unica utility programs made by using the col program.

FUNCTION	MICROTOOLS	UNICA
Concatenate files	cat.com	cat.com
List words in file	deform.com (option)	wx.com
Compare text files	diff.com	sc.com
Search for regular expression in file	grep.com	sr.com
Create file link	ln.com	ln.com
Create pipeline without Microshell	p.com	(not necessary)
Concatenate files horizontally	paste.com	hc.com
Sort lines in memory	sort.com	srt.com
Save temporary file from pipeline	tee.com	tee.com
Find unique lines in file	uniq.com	srt.com (option)
Count words, lines, characters	wc.com	wc.com
Print files in columns	col.com	n/a
Print lines common to two files	com.com	n/a
Encrypt file	crypt.com	n/a
Cut columns from file	cut.com	n/a
Remove editor commands	deform.com	n/a
Echo arguments	echo.com	n/a
Search for string in file	find.com	n/a
Get drive, user for Microshell	get.com	n/a
Merge sorted files	merge.com	n/a
Get item from list for Microshell	next.com	n/a
Print files in pages	pr.com	n/a
Print records on separate lines	rec.com	n/a
Delay processing	sleep.com	n/a
Split file into pieces	spl.com	n/a
Find strings in binary file	str.com	n/a
Compare binary files	n/a	bc.com
Copy file(s)	n/a	cp.com
Create disk allocation map	n/a	dm.com
Compute file CRC	n/a	fid.com
List contents of directory	n/a	ls.com
Change name of file	n/a	mv.com
Set (change) file attributes	n/a	sfa.com
Find spelling errors	n/a	sp.com
Transliterate characters in file	n/a	tr.com
Look up words in dictionary	n/a	wl.com

mand interpreter. The Unica programs, on the other hand, are designed to stand alone, although I have used most of them under Microshell with no serious ill effects. The Microtools programs were written in C (alas, no source code is included). The Unica utilities, by contrast, were written in a structured Z80 assembly language. As a result, the Microtools programs tend to be somewhat larger and slower than their Unica counterparts.

Microcomputer Software Tools

The Microtools packages are distributed by New Generation Systems of Reston, Virginia, the manufacturer of Microshell, and their compatibility with Microshell is one of the main features of the programs. As you might suspect, the company recommends Microshell for use with Microtools.

The Microtools programs, however, can also work with the normal CP/M command interpreter. They contain code to perform input and output redirection and a special, separate utility simulates pipelines. It works by creating a file for submit.com, the batch-processing program supplied with CP/M.

Nevertheless, pipelines are much simpler and cleaner under Microshell. And Microshell provides many other features that these programs can use. The most important is the ability to create "shell files," also known as shell procedures. As the name implies, these files are executable procedures. Their components are whole programs rather than the statements of a programming language.

Two Microtools programs, get.com and next.com, are designed especially for Microshell. They manipulate values in memory that can be used within shell files to pass parameters to programs or to alter program flow.

For example, next.com and another Microtools program, find.com, can be used to create a shell file for erasing some members of a group of related files. This shell file is invoked by typing

```
eraq <ambiguous filename>
```

after which you're prompted for the files you want to erase.

The source code—a normal text file—is shown in listing 3. The first line uses the -w option of the find program

NEVADA

FORTRAN™

"If you want to learn or teach someone FORTRAN, this is the package to buy." *ACCESS*, March/April 1983.

Perfect for teaching FORTRAN. Perfect for learning FORTRAN. Perfect for Scientists and Engineers. Based upon the ANSI-66 standards (FORTRAN IV), advanced features include IF...THEN...ELSE constructs. COPY statement. CHAINING with COMMON. TRACE style debugging and 150 verbal error messages. What's more, you can intermix in-line FORTRAN and Assembly Language statements for those special Micro needs! Get yours today. Diskette comes with 214-page manual.

NEVADA

PILOT™

Why has Nevada PILOT become so popular? It's definitely easier to learn than BASIC. The documentation (114 pages) by Professor Starkweather is exceptional! And, it meets all the PILOT-73 standards with many new features, including a built-in full-screen text editor.

Perfect for training, testing, virtually all programmed instruction and word puzzle games. Order yours now! Diskette and manual come with 10 FREE programs.

NEVADA

EDIT™

"A well-thought-out product with excellent documentation and an astoundingly low price." *Microcomputing*, May 1983

Now, high quality text editing for micros. Nevada EDIT is great for program editing, as it was designed specifically to create COBOL, BASIC, and FORTRAN programs. It's a character-oriented full-screen video display text editor.

Simple to configure. You can customize tab stops, default file type, keyboard control key layout, and CRT by menu selection.

CP/M is a registered trademark of Digital Research, Inc. TRS-80 is a registered trademark of Tandy, Corp. Apple II is a trademark of Apple Computer, Inc. Osborne is a registered trademark of Osborne Computer Corp. Xerox 8010 is a trademark of Xerox Corp. Kaypro is a trademark of International Systems Development Corp. Health is a trademark of Health Corp. IBM is a trademark of International Business Machines Corp. Nevada COBOL, Nevada FORTRAN, Nevada PILOT, Nevada EDIT and EDIT are trademarks of Ellis Computing, Inc. © 1983 Ellis Computing, Inc.

NEVADA

COBOL™

Nevada COBOL is based upon the ANSI-74 standards with many advanced features. It's field-proven with thousands of users world-wide in Business, Government and Education. The excellent documentation (165 pages) is used as a classroom text at a number of colleges.

Because of Nevada COBOL's superior design, it requires about half the memory of competitive COBOL compilers. This major advantage is just one reason many business programmers are switching to Nevada COBOL.

And, lots of students are using Nevada COBOL because it's the affordable, easy-to-use COBOL! Order yours now!

Also available: COBOL Application Packages, Book 1, \$9.95.

Nevada FORTRAN and Nevada COBOL are now available for the Commodore-64 from Commodore Business Machines, Inc.

To make our software available to even more micro users, we've slashed our prices. What's more, we're offering a money back guarantee. If for any reason you're not completely satisfied, just return the package — in good condition with the sealed diskette unopened — within 30 days and we'll refund your money.

This is a limited time offer, so order yours today!

\$ 29.95
each

MAIL TODAY! To: Ellis Computing, Inc.
3917 Noriega Street
San Francisco, CA 94122
(415) 753-0186

The CP/M* Operating System, an 8080/8085/Z80 microprocessor, and 32K RAM are required.

Software Packages: COBOL FORTRAN PILOT EDIT

Diskette Format: 8" SSSD (Standard IBM 3740 format)
5 1/4" Apple CP/M Xerox 820 (Kaypro) Osborne
 Televideo Micropolis Mod II North Star DD North Star SD
 TRS-80 Mod I with CP/M (4 1/2" 4200 hex) TRS-80 Mod I/Mapper
 Heath Hard (Z-89) Heath Soft (Z-90)
 Superbrain DD DOS 3.X (512 Byte sectors)

Shipping/Handling Fees: Add \$4.00 for the first package and \$2.00 for each additional package. **OVERSEAS** add \$15.00 for the first package and \$5.00 for each additional package. Checks must be in U.S. funds and drawn on a U.S. bank!

Send my order for _____ packages @ \$29.95 each Total _____
COBOL Applications package @ \$9.95 each Total _____
In CA add sales tax _____
 Check enclosed Shipping/handling _____
 MasterCard Visa Total _____

_____ Exp. Date _____

Signature _____

Ship to:
Name _____

Street _____

City/State/Zip _____



ELLIS COMPUTING™

Listing 2: Using shell files and pipelines. A sample telephone listing (a) is encrypted by the Microtools crypt program using the password "justice" (b). Getphone.sub, a simple Microshell shell file containing a pipeline, is shown in (c). It reads the encrypted file, phones.cpt, using the d(encrypt) option of the crypt program with the second argument of the command line (the password). The output of the crypt program is then "piped" (using the | symbol) to the grep pattern-matching utility. An invocation of getphone.sub under Microshell is shown in (d). The tilde (~) character indicates that the name johnson begins with an uppercase "J." (The Microshell prompt is "AO>".)

(2a)

```
Blair, John          789-1796
Chase, Samuel       796-1811
Cushing, William   789-1810
Iredell, James     790-1799
Johnson, Thomas   791-1794
Johnson, William  804-1834
Livingston, Brockholst 806-1823
Moore, Alfred      799-1804
Paterson, William  793-1806
Todd, Thomas       807-1826
Washington, Bushrod 798-1829
Wilson, James      789-1798
```

(2b)

```
X2*8;TO#XT'      )4E<FFGK          e-,8)WU8I[ ]LZ          BJA7BS\_
Z+O/@HGfY7Sfil^iDUYSQWW`
k:'%->Nqk/EXZx  ?@>EYbjd_.7@KA?dbF]jbUn%
OWIDO_qod((8MLQi\ :ViloaLHPWVTZ\g          q4;-9<X\]Vsn:zztvr '>B f]jk ))$
elAG@aT|Q[jc\?QTNLRQ_ w.;+?JVX|j@Yfvvtz          JV` ]gh_l
~<71XS1U_cQb    HCP@CQUi!%62=RNvTywI #r{ "dleYdu )w(2COquc,J`hy          <DOSZfb`
```

(2c)

```
%break off : ignore attempts to interrupt command
crypt -dp $2 phones.cpt | grep $1
%break on
```

(2d)

```
AO> getphone ~johnson justice
Johnson, Thomas    791-1794
Johnson, William   804-1834
```

AO>

to list all files matching the ambiguous file reference. Find lists one filename on each line. The list is placed in the temporary file 0raq.tmp using Microshell's output redirection.

Next.com fetches the name of each program from the list in sequence, erases it from the temporary file, and places it where the Microshell command interpreter can find it. The shell file then prints each filename, asking whether the file should be erased. Depending on the answer, the shell file either erases the file or loops immediately to the next filename. The percent (%) character introduces intrinsic Microshell commands; %print <string> outputs a string to the console terminal. The result is a new CP/M utility "program." It works more slowly than a compiled program, but it took only a few minutes to create and debug.

The Microtools programs can also be used independently. For example, I used the program col.com to create the columns in listing 1. Listing 4 shows part of the source file that was fed to col to produce it.

The fact that the programs can work together smoothly is also very important. It makes it possible to create new procedures by constructing shell files. For example, using Microshell and the Microtools utilities, it would be relatively easy to construct a menu-driven software shell, or "front-end", for CP/M.

This front-end processor displays the commands that are available and prompts you in your choice.

Or a simple spelling aid could be created from the Microtools deform.com, sort.com, and uniq.com. Deform (with the -w or word-list option) would break a text file into individual words, one per line. The output of deform

Listing 3: *Eraq.sub—a Microshell shell file to erase multiple files, with a query before each erasure. The shell file (a) uses two Microtools programs, find.com and next.com. The syntax is eraq <ambiguous filename>. An invocation of eraq.sub under Microshell is shown in (b).*

(3a)

```
find -w $1 >eraq.tmp
%loop
    next eraq.tmp
    %memstr %l
    %if %l = done then goto fin
    %print -n "Erase "
    %print -n %l
    %print -n " (y/n)? "
    %getchr %AS <$T
    %print
    %locase %AS
    %if %AS NE y then goto %loop
    era $l
    %print -n %l
    %print " erased"
    %goto loop
%fin
era eraq.tmp
%exit
```

(3b)

```
A0> eraq byte*.txt
Erase BYTE882.TXT (y/n)? y
BYTE282.TXT erased
Erase BYTE1282.TXT (y/n)? y
BYTE1282.TXT erased
Erase BYTE183.TXT (y/n)? n
Erase BYTE283.TXT (y/n)? n
Erase BYTE883.TXT (y/n)? n
```

A0>

Listing 4: *The source file for listing 1. The file was fed to the Microtools program col.com to produce the multicolumn output. Only the first 39 lines of this file are printed.*

```
FUNCTION
MICROTOOLS
UNICA

Concatenate files
cat.com
cat.com
List words in file
deform.com (option)
wx.com
Compare text files
diff.com
sc.com
Search for regular expression in file
grep.com
sr.com
Create file link
ln.com
ln.com
Create pipeline without Microshell
p.com
(not necessary)
Concatenate files horizontally
paste.com
hc.com
Sort lines in memory
sort.com
srt.com
Save temporary file from pipeline
tee.com
tee.com
Find unique lines in file
uniq.com
srt.com (option)
Count words, lines, characters
wc.com
wc.com
```

NOT ONLY ANOTHER TECHNOLOGICAL BREAKTHROUGH BUT ALSO EASY TO USE AND TO INSTALL

Modems are the most important device used to link two products together through ordinary telephone lines at miles apart. The INCOMM STARCOM, a 300/1200 bps Auto Dial, Auto Answer, Auto Log On modem was introduced to

link two high speed devices together with having absolutely NO knowledge of computers or communications in general. Anybody can install and operate the STARCOM Family in a few minutes.

- STARCOM is a 300/1200 bps Auto Dial/Auto Log On/Auto Answer Modem.
- OSCOM is a 300/1200 bps Auto Dial/Auto Log On/Auto Answer with Osborne (TM) Computer Software (included) modem.
- COMSOFT is a communication software package.
- OEM MODEM BOARD is also available for custom installation.

THE
STARCOM
\$450.



THE
OSCOM
\$520.



**SEND FOR
FULL LINE
CATALOG**
of peripherals including Modems, Muxes, Switches and Breaker Boxes.

**DEALER INQUIRIES
INVITED**
(312) 459-8881
or 1-800-323-2666

INCOMM

115 N. WOLF RD. WHEELING, IL 60090

SO COMPACT:
Only 1 1/4" x 6 1/2" x 7 1/2". 1.5 lbs.
Fits in your coat pocket!



“Your Portfolio, Sir.”

DOW JONES INVESTMENT EVALUATOR™ — the computer software that serves your personal investment needs at home, accurately and efficiently.

A Personalized System

With the INVESTMENT EVALUATOR, your home computer and a telephone modem, you have a personalized system for managing your portfolio. A system that automatically updates and tracks only those stocks you want to follow — allowing you to evaluate your position at a glance.

Easy Access to News/Retrieval®

This software automatically dials and connects you with Dow Jones News/Retrieval®, the world's leading supplier of computerized information on demand. It allows you and your family access to current quotes, financial and business news, general news, movie reviews, sports, weather and even the Academic American Encyclopedia.

The Right Amount of Software for the Job

The INVESTMENT EVALUATOR gives you the capabilities you need without making you pay for a lot of complex functions you may never use. Menu screens lead you to what you want with one-touch commands. The program is completely reliable, comes with an easy-to-follow manual and is fully supported by the Dow Jones Customer Service hotline.

From Dow Jones, Publishers of The Wall Street Journal

Dow Jones has been serving the business and financial communities for over 100 years. Now Dow Jones Software™ serves you at home.



For a free brochure call:
1-800-345-8500 ext. 262
(Alaska, Hawaii and foreign
call 1-215-789-7008 ext. 262)

DOW JONES SOFTWARE™

Dow Jones Investment Evaluator™

Available for Apple II, Apple IIe, IBM PC and TI Professional. Compatibility with Atari and Commodore to follow.

...Bank on it.

Copyright © 1983 Dow Jones & Co., Inc. All rights reserved.

Unica: an Update

There has been one major change in the Unica utilities since BYTE last reported on them. The package now includes an outstanding implementation of the Unix utility `grep`, which stands for "Globally look for Regular Expressions and Print."

`grep` is a pattern-matching program. The pattern is a regular expression, composed of normal characters and "metacharacters." The metacharacters generate ambiguously defined patterns that `grep` then searches for. For example, the command

```
grep BYTE . *page <filename>
```

will find all lines in a file that contain the word "BYTE" followed by the word "page" and then print them on the console.

An implementation of `grep` is included with the Microtools package. It is roughly equivalent to a version of `grep`, originally distributed by the DEC users' group, DECUS. I adapted it for CP/M and placed it in the public domain earlier this year. In fact, the public-domain program is a bit faster than the Microtools version. (The program is available for the taking from a number of remote CP/M systems around the country.)

The Unica program `sr.com` is considerably more sophisticated. It accepts full regular expressions, including conditionals. For example, the command

```
sr unix:microtools:unica <filename>
```

will print each line containing the words "Unix," "Microtools," or "Unica." Each subexpression can contain metacharacters and be of arbitrary complexity.

The astonishing thing about `sr` is that it is more than twice as fast as either the public-domain or Microtools programs, neither of which permits conditional expressions. The key is a better algorithm—better, as it turns out, than the one used by the Unix utility that matches full regular expressions, `egrep`.

A character-transliteration program has also been added to the Unica package. This enables you to make certain substitutions in text files. For example, Unica's `tr.com` can be used to map all the characters in a file to either lowercase or uppercase.

A spelling program, which was almost unusable in the first release of Unica, has been improved. A large dictionary is now available. Unfortunately, the program still doesn't recognize many common variants of root words. And it is much slower than the commercial spelling programs I have seen.

The developers of Unica have taken obvious care to make sure its documentation is properly updated to reflect the current versions of the programs. I wish every software vendor were as conscientious.

would be passed to `sort.com` in a pipeline. `Sort`, in turn, would put the lines (words) in alphabetical order. `Uniq.com`, the last program in the pipeline, would filter out duplicate words. The result: a list of the individual words in the text file, in alphabetical order. The list could then be scanned for any possible misspellings.

Unfortunately, `sort.com` uses a relatively slow "shell sort" algorithm. It took almost twice as long to sort a file of 1000 words as my homegrown in-memory sorting program, which was created with the same compiler that was used for the Microtools but which utilizes a "quick-sort" algorithm. The Unica sorting utility, which was written in a form of assembly language, was faster yet.

Used intelligently, the Microtools programs can be put

together to provide some of the facilities of a simple database management system. One of the examples in the well-written manual shows how you can take a text file containing lines of the form—name:address:phone:notation, then cut it up, reformat it, and use it to print mailing labels.

The manual is well organized and clear. But because the idea of connecting programs together is probably a new one for most CP/M users, more examples would be useful. ■

Christopher O. Kern (201 I St., SW, Apartment 839, Washington, DC 20024) is a journalist and computer hobbyist. He is a frequent contributor to BYTE.

ULTRA-RES™ GRAPHICS

IEEE-696 S-100

IBM-PC

- 1 X 512 X 512 \$495

- 1 X 512 X 512 \$495

- 3 X 512 X 512 \$1250

- 1 X 1024 X 1024 \$995

- 1 X 1024 X 1024 \$995

FEATURES

Software drivers, Hardware zoom, Programmable Display Resolution, Windowing, Multi-Controller Capability, NEC UPD7220 Graphic Controller

Starting Prices

ULTRA-RES Trademark CSD Inc.

IBM-PC Trademark IBM

C.S.D. Incorporated
P.O. BOX 253 Sudbury, MA 01776
(617) 443-2750

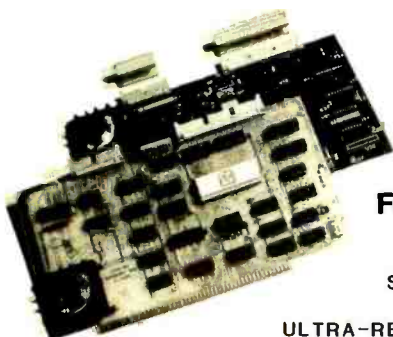

dBASE

BREAK THROUGH

dBASE II is a trademark of
Ashton-Tate

Announcing

the most sophisticated database program development tools available on any personal computer anywhere.

The Database

ACCELERATOR™

Automatic program, screen, menu, report generation.
Automatically checks, formats, documents your programs.
Now available for the IBM PC at an introductory
price of \$195. 30 day money back guarantee.

from
Optimal Software

The Database Accelerator is a
trademark of Optimal Software.

Distributed by Programming International
505 Hamilton Avenue, Suite 301, Palo Alto, CA 94301
(800)222-8811 inside California; (800)631-4400

Dealer Inquiries welcome.

Also available at
SOFTWARE
to go
and other fine
software dealers

Mainframe Graphics on a Microcomputer

Display Tektronix-type plots on your microcomputer

by Mahlon Kelly

Did you ever wish you could display complex graphics displays on your microcomputer? Interfacing a microcomputer to a mainframe gives you several advantages. You can double or triple the capabilities of your system. But not all the power of a mainframe is easily available. The high-resolution graphics available on most mainframes require expensive graphics terminals. Except for simple line-plot graphics, most microcomputers don't have the speed or software to handle mainframe graphics.

If you have a microcomputer capable of high-resolution graphics and a smart-terminal program, it's possible to display high-resolution mainframe graphics previously requiring expensive terminals. Just save the mainframe's output as a disk file, then display it on your microcomputer's screen. It's only a matter of converting the output from the mainframe system into a form that your computer will understand.

Tektronix (the oscilloscope company) was the first to produce a high-resolution graphics terminal for large computers. Along with the terminal it produced the software that generated the code necessary to tell the terminal what to do. This set a de facto standard for the industry. Most large computers will produce the code to

drive Tektronix terminals. But how can you put the display on the screen of your microcomputer?

The Problem

My research work generates a lot of data that must be interpreted visually. (See "Data Collection with a Microcomputer," March 1983 BYTE, page 295.) The recorded data are sent to a Cyber computer, where they are processed and massaged in various ways. The reduced data are then sent back to my microcomputer for further processing and storage.

The problem is that I can get a good look at the data using various graphics programs, but those programs send output only to a Tektronix terminal or some other terminal that's configured to think it's a Tektronix. (The Retrographics package produced by Digital Engineering for the ADM-3A is a good example.) I was spending too much time commuting between my own LNW-80 microcomputer and our University's Tektronix facility. I needed to send the graphics output to my microcomputer and display it on the screen. Although that seemed difficult at first, it took only a 30-line BASIC program to do the whole job (it took about two weeks of spare time to figure out how). The Tektronix emulation pro-

gram (see listing 1) has been developed for LNW-BASIC on the LNW-80, a microcomputer that is functionally the same as the TRS-80 Model I but that, among other features, has both high-resolution black-and-white and color graphics. The program can easily be translated to other versions of BASIC.

Communications

To understand how the Tektronix terminal works, it's important to understand how computers and terminals communicate over the phone lines. Most terminals respond to ASCII (American National Standard Code for Information Interchange) characters that are transmitted bit by bit. The Tektronix does everything in response to ASCII characters. These characters consist of seven bits of information that can be converted into a set of 127 different decimal-based numbers or an equivalent number of alphanumeric and control characters. The first 31 ASCII characters are control characters. They tell a "normal" terminal what to do. For example, an ASCII 7 tells the terminal to beep or sound a bell, an 8 tells it to do a backspace. Characters 32 through 63 represent various special characters such as *, ?, %, and the numbers 1 through 9. The characters 64 through 95

Listing 1: *The Tektronix emulation program to translate a file of Tektronix graphics control characters to a plot on a microcomputer screen. The program is designed for an LNW-80, but only five lines need to be changed to adapt it to other machines.*

```

10 ' THIS PROGRAM TO PLOT A FILE IN EMULATION OF A TEKTRONIX TERMINAL HAS BEEN DESIGNED TO BE USED ON A LNW-80.
20 ' THE FIVE LINES WITH A REMARK STATEMENT STARTING WITH '****' USE THE LNW-BASIC GRAPHICS LANGUAGE. THEY SHOULD BE
30 ' MODIFIED FOR WHATEVER SYSTEM IS TO BE USED. THE PURPOSE OF THOSE LINES SHOULD BE SELF-EXPLANATORY.
40 '
50 '
60 CLEAR 1000
70 MODE 1 ' **** PUTS THE LNW IN HIGH RESOLUTION MODE
80 ' **** IN LINE 40 PCLS CLEARS THE HIGH RESOLUTION SCREEN; CLS CLEARS ALPHANUMERIC.
90 PCLS: CLS: HX=0: HY=0: LX=0: LY=0: OLD=0: CH=0
100 FLAG$="T" ' TELLS THE PROGRAM TO EXPECT TEXT AS A DEFAULT
110 PRINT "WHAT IS THE INPUT FILE NAME? ";
120 LINEINPUT FILE$
130 '
140 ' START THE INPUT.
150 '
160 OPEN "I",1,FILE$ ' OPEN THE INPUT FILE.
170 LINEINPUT #1,A$ ' LINEINPUT BECAUSE THE STRING MAY HAVE UNPRINTABLE CHARACTERS.
180 IF LEN(A$)=0 GOTO 170 ' IF THE INPUT WAS A NULL STRING, GET ANOTHER.
190 '
200 FOR I=1 TO LEN(A$) ' LOOK AT THE WHOLE STRING CHARACTER BY CHARACTER.
210 OLD=CH ' SAVE THE ASCII VALUE OF THE PRECEDING CHARACTER.
220 CH=ASC(MID$(A$,I,1)) ' LET CH = THE ASCII VALUE OF THE CHARACTER POINTED TO.
230 IF CH=29 FLAG$="B" ' IF THE CHARACTER IS A CONTROL GS, SET A FLAG SO THAT THE PEN WILL BE MOVED BUT THE LINE NOT DRAWN.
240 IF CH=12 AND OLD=27 THEN CLS: PCLS ' IF THE CHARACTER PAIR ESC,FF WAS RECEIVED, CLEAR THE GRAPHICS AND ALPHANUMERIC SCREEN.
250 IF CH=31 THEN FLAG$="T" ' IF US WAS RECEIVED, SET THE FLAG TO EXPECT ALPHANUMERIC INPUT.
260 IF CH<32 GOTO 290 ' IF THE CHARACTER IS A CONTROL CHARACTER, JUMP.
270 IF FLAG$="T" PRINT CHR$(CH);GOTO 290 ' IF IN TEXT MODE, PRINT THE CHARACTER AND GET ANOTHER.
280 GOSUB 350 ' BRANCH TO THE SUBROUTINE THAT DECIDES WHAT THE GRAPHICS CHARACTER DOES.
290 NEXT I ' GO GET ANOTHER CHARACTER.
300 IF EOF(1) THEN CLOSE: STOP ' QUIT IF FILE DONE.
310 GOTO 170 ' GO GET ANOTHER STRING.
320 '
330 ' FOLLOWING IS A SUBROUTINE TO DECIDE WHAT TO DO WITH THE GRAPHICS CHARACTERS.
340 '
350 IF CH>31 AND CH<64 AND OLD>95 AND OLD<128 THEN HX=CH: OLD=CH: RETURN ' IF THE CHARACTER IS A 'HI'
360 ' AND THE PREVIOUS WAS A 'LO Y', THEN THE CHARACTER IS A 'HI X' (SEE TEXT).
370 IF CH>31 AND CH<64 THEN HY=CH: OLD=CH: RETURN ' IF THE CHARACTER HAS A VALUE BETWEEN 31 AND 64,
380 ' THEN IT'S A 'HI Y'; IT ISN'T A 'HI X' BECAUSE IT PASSED THE TEST OF THE PREVIOUS STATEMENT.
390 IF CH>95 AND CH<128 THEN LY=CH: OLD=CH: RETURN ' IF THE CHARACTER VALUE IS BETWEEN 95 AND 128 THEN IT'S A 'LO Y'.
400 IF CH>63 AND CH<96 THEN LX=CH: OLD=CH: GOSUB 440: RETURN ' IF THE VALUE IS BETWEEN 63 AND 96 THEN IT'S A 'LO X'; DO A PLOT.
410 '
420 ' SUBROUTINE FOR ACTUAL PLOTTING; CHANGE LINES 480 AND 490 FOR APPROPRIATE SCREEN RESOLUTION. SEE TEXT.
430 '
440 X=.47*((HX-32)*32+LX-64) ' **** CONVERT HX AND LX TO THE VALUE OF X TO BE PLOTTED. SEE TEXT.
450 Y=.25*((HY-32)*32+LY-96) ' **** CONVERT HY AND LY TO THE VALUE OF Y TO BE PLOTTED. SEE TEXT
460 DRAW "XFLAG$,MX,Y" ' **** IF FLAG$="B" MOVE TO X AND Y BUT DON'T DRAW. IF FLAG$="A" THEN MOVE AND DRAW.
470 FLAG$="A" ' SET IT SO THE NEXT LINE WILL BE DRAWN.
480 RETURN

```

represent uppercase letters and a few symbols like @. From 96 through 127, the input represents lowercase letters and a few other symbols. While most terminals will respond to the ASCII codes—that is, they will print a B when the code 66 is sent—the Tektronix can either act like a normal terminal or interpret the characters to draw straight lines.

That's all the Tektronix terminal can do. In terms of graphics, all it can do

is draw straight lines. Think of it as a plotter with a point on the screen that can move from one point (specified as an *x,y* coordinate) to another point. It can move the pen in a down or lifted position; that is, it can move it and draw a line or move it without drawing a line. Of course, very short, straight lines when combined end to end can look like a curve. Everything on a Tektronix screen is the product of a series of straight lines, written

with the pen either in the up or down position.

How can this help you use a microcomputer to plot a graph intended for a Tektronix? First, you need to receive the characters intended for the graphics terminal. If you have a good smart-terminal package and you can access a mainframe, tell the mainframe that you are using a Tektronix terminal (you would tell the same lie if you had a modified ADM-3), set it

Listing 2: Part of an output file giving directions for a graphics plot on a Tektronix terminal. Although it may look like garbage, it produces very precise instructions and plots.

```
AZcChF1HnKpMPoRmUjWgZdI`_$_|/BwDrGmIhLbN#|QwSrVmXiCeJa0@"^CCEXhvJtMsOrRTWsYu\x^|1
AC#dFkIrKkYn#ePhSpUwX^ZzeJj_lo2ErDtGJLs0qQoT1VjYgEd^`3@#3CxEsHoJjMfPeR#U|WgZv\l_r4
ApDnFmIkKNPSlUmXoCsJx5@CB^E#BghJpLx0Z`QfTiUnYr\l^v6ACFuHtKqMoPmRjUgWdZaJ#D_z7Bvd
rGoIkLiNfQdSbV`X#e|J|C8@zCyEHJMOCER|T3W^Y\#a^c9ACdFIKNePffSgUiXjZJ_i;BqDeGcIaL`O#Q
^T3vCYgCw^"r#DFIKNPKRSUVXCJrZ@BBEGHJMORTVYCL^r#ACFGIKMMPRUXYZJ_r^BDGIKLNQRSVYCEJ
r(@BDEHJMOPRUUVWY\^r)ABDFHIKPNSTUXZZJ_r*BEFGJLMNQTUVYCE^_r+ACEHJKMPQ:UEUwtU$1ACDFI
KNOQSVVXZJr-@BBEGHJMORTTUVYZ\^r.ACfHKLNPruwxzJ__r/BDFIKLNQqsvyCJ^r0@BCEHJMooRTUwZ
\^r1ACfHIKnpRtVXZZJ_r2BEFGJLLNQTUVYCE^r3@CFHJJMOQRUWZ\J_r4BCDFIKNOQSVVXCEJr5@ABEG
GJLORSTUVYZE^r6ACFFHKLNPruwxzJ^_r7BDGIJLNPQSVXCE\^r8@CCEGJMooRTUwZ\^r9AACFGIKNPSUX
YZJ_r;BDEGJLLORQSVYCE^^i;MGJf1FnGMlNjNiMoNqNrMnqMnrNmQmVnWmGx^fCFJGM:ENxNwM3NMG#^fb
FcGmbN`N"M#eN"rCr;^#o^o;CeGgFiFjGHiIqIiIjKMiNgNeMiNnNoMnNmNoMnMsNtMGuFxFyGMxNuN
tMzNcMG3FFZ^GM#N3NcMzAn#oCo;^&k^k;CqGfFcFbGMcNfNgLfKbLhNkNlNmNkMnNlNmKpNqMGrFuFvG
MuNrNqMwNxMGyF|F3GM|N3NxM^NkCk;^(\^h;C^M^NcNdMGcF^F^H^I^dIeNh
```

up to send the output for a plot, and then save the output to a disk file. You may have to change the translation tables in your smart-terminal program so that the control characters aren't changed, but that should be straightforward. You now have a file that was intended to produce a plot. It will look like garbage (listing 2 shows part of such a file), but it really does have meaning.

How does the Tektronix interpret the characters it receives to draw a line? This is the hard part. First, remember that it only draws a straight line from a point where the last line left off to a new point specified by X and Y coordinates with the pen either lifted or down. (At the start of a program the terminal assumes the pen to be at coordinates

0,0.) The terminal has to receive 4 bytes (actually four 7-bit characters between 0 and 127 decimal) to know where to end the line. There's not enough information in a single byte to specify an X or Y coordinate, so each coordinate uses 2 bytes. The bytes are called Hi X (HX) and Lo X (LX) and Hi Y (HY) and Lo Y (LY); Hi specifies the larger part of the number for the coordinate and Lo specifies the smaller. HY and LY are converted to a value corresponding to a Y coordinate and HX and LX do the same for X. The numbers are stored, and as soon as an LX is received, the terminal responds by drawing a line. When it receives HX, HY, or LY, it simply stores them while waiting for the LX.

How does the terminal know

whether the character it receives is an HX, an LY, or whatever? Remember that each character that's received has an associated numerical value. If the value is between 64 and 95, it's an LX. If it's between 96 and 127, it's an LY. If it's between 32 and 63, it can be either an HX or an HY. If the Hi number is *immediately* preceded by an LY, then it is an HX; otherwise it's an HY. So the terminal stores LX and LY according to the value of the incoming byte, and it stores HX or HY according to the value of the byte and whether the previous byte was an LY.

You might think that the computer would send 4 bytes for every line to be plotted, but it doesn't. Because the line is often short, HX and HY change infrequently, and often only X or Y changes. To wait for 4 bytes

RADIO SHACK COLOR COMPUTER MODEM COMMUNICATIONS

Make your Color Computer an intelligent printing terminal with off-line storage!

- Talk to a timeshare system or information service
- Print out what is received as it is received
- Save received text to cassette tape
- Re-display the received text even while on-line
- Communicate with other computers
- Using your computer as a general-purpose 300-baud terminal
- Downloading programs from other computers

The Microtext module is a program pack containing not only firmware but a second serial port so that both your printer and modem can be connected at the same time. Microtext can be configured for any serial printer that will work with the Color Computer, even if it requires line feeds! But even if you don't have a printer, you can keep a permanent copy of your data by storing to cassette tape. Also, any Radio Shack/Centronics-compatible parallel printer may be used by adding the Micro Works' P180C parallel interface.

For those of you with special terminal applications, Microtext has selectable parity; it sends odd, even, mark or space. With mark parity (which is default) you can send to computers requiring either seven or eight bits. All 128 ASCII codes can be sent. Exchange programs with other Color Computer users! Basic programs may be downloaded from other computers or timesharing systems.

You'll find many uses for this versatile module! Available in ROMPACK, ready-to-use, for \$59.95

PLUS

First-rate Programming Tools • Books • Games • Memory Upgrade Kits
Hardware • Keyboards • Parts

THE MICRO WORKS

P.O. BOX 1110 DEL MAR, CA 92014 619-942-2400

to be sent when 1, 2, and 3 would do is very inefficient. Of course, if HY, LY, HX, and LX are sent in that order, all will be stored, and that's OK with the terminal. However, if only the Lo X value must be changed, then only an LX is sent (remember that a line is drawn whenever an LX is received). If LY and LX must be changed, two bytes will be sent (LY and LX). If HX and LX must be changed, then LY, HX, and LX will be sent in that order. The LY tells the terminal that the Hi byte is an HX and not an HY. If HY and LX must be changed, then HY and LX are sent. To change all 4 bytes, all 4 bytes are sent.

Once the terminal has 4 bytes in memory and it receives an LX, how does it know where to draw the line? First, the line starts at the end of the last line. That's simple. The end of the *new* line is specified by HY, LY, HX, and LX as they are stored in memory. The coordinates are calculated as follows:

$$X = (HX - 32) * 32 + LX - 64$$

and

$$Y = (HY - 32) * 32 + LY - 96.$$

Those equations are for a Tektronix terminal, and that terminal has a maximum value for X of 1024 and a maximum for Y of 780. You must multiply X and Y by appropriate factors if your screen has a lower resolution. For example, my LNW has a maximum resolution for X of 492, and I must multiply X by 492/1024 to have all of the plot on the screen. A few computers expect Y=0 to be in the upper left-hand corner. In that case, subtraction is needed, as for my LNW. For the LNW, $Y = 192 - (192/780 * ((HY - 32) * 32 + LY - 96))$ and $X = 492/1024 * ((HX - 32) * 32 + LX - 64)$ will produce a plot with X=0 and Y=0 in the lower left-hand corner.

The terminal also responds to control characters. The two most important characters have ASCII values of 31 and 29. Remember that the terminal has two modes of operation: graphics and alphanumeric. If it's in graphics mode and receives a 31, the

terminal sets itself to alphanumeric mode and will print the string "rose" not as the flower but the word. If it receives 31 while in alphanumeric mode, it will do nothing. If it receives a 29 while in alphanumeric mode, it will go into graphics mode. The first coordinate it receives (as HY, LY, HX, LX) will make it move its pen, but with the pen raised, thus going to a new line origin. The second set of coordinates will make it draw a line. Each set of coordinates after that will produce another line. If it receives a 29 in graphics mode, the pen will be lifted and go to the next set of coordinates to be received. If the received coordinates are exactly the same as were previously received, then a single point will be drawn. Using this scheme any shape can be drawn, and the pen can be moved around to plot anywhere on the screen (if a 29 is sent first).

There are other control codes. The most important is a sequence of two bytes: 27 (escape) and then 12. This tells the terminal to erase the screen, both the graphics and alphanumeric modes. The code 26 erases the alphanumerics but not the plot.

It should be possible for some enterprising programmer who understands mainframe graphics to write a smart-terminal program for most microcomputers that would eliminate the step of storing the graphics file and then displaying it with a BASIC program. The microcomputer, in other words, would act just like a Tektronix terminal with the plot appearing as it came in over the phone. The advantages would be that the plot could be stored on disk and sent to a point-addressable printer. Writing such a program is beyond my ability and ambition.

Tektronix has defined the most simple and efficient way to transfer graphics output. If the procedure is understood by microcomputer programmers, we will soon have smart terminals that have the ability to receive not only alphanumeric output but graphics displays as well. ■

Mahlon Kelly (268 Turkey Ridge Rd., Charlottesville, VA 22901) is associate professor of Environmental Sciences at the University of Virginia.

To find out where we're showing off the P1350 printer, call one of these Toshiba distributors:

- COMPU SHOP
1355 Glenville Drive
Richardson, TX 75081
(214) 783-1252
- CYPRESS DISTRIBUTING CO., INC.
1266 Lincoln Avenue
Suite 109
San Jose, CA 95125
(408) 297-9800
- DIGITAL ENTRY SYSTEMS
27 Spruce Street
Waltham, MA 02154
(617) 899-6111
- GENERAL BUSINESS COMPUTERS, INC.
2 North Olney Avenue
Cherry Hill, NJ 08003
(609) 424-6500
- GENERAL MICROCOMPUTER
Georgetown Center
52303 Ermons Road #26
South Bend, IN 46637
(219) 277-4972
- INTECH GROUP
Royal Commerce Center
2025 Royal Lane
Dallas, TX 75229
(214) 241-1717
- KALTRONICS DISTRIBUTORS, INC.
702 Landwehr Rd.
Northbrook, IL 60062
(312) 291-1220
- MICRO DISTRIBUTORS
11794 Parklawn Drive
Rockville, MD 20852
**(301) 468-6450 or
(800) 638-6621**
- MICROAMERICA DISTRIBUTING CO.
17103 Kingsview Avenue
Carson, CA 90746
(213) 327-6030
- 1050 Remington Road
Schaumburg, IL 60195
(312) 882-0095
- 366 Washington Street
Wellesley, MA 02181
(617) 431-7660
- 1461 Exchange Drive
Richardson, TX 75081
(214) 235-3616
- MICROWARE DISTRIBUTORS, INC.
20415 S. W. Blanton Avenue
Aloha, OR 97007
(503) 642-7679
- MIDTEC ASSOCIATES
8363 Ouwira Road
Lenexa, KN 66215
(913) 541-1711
- MONROE DISTRIBUTING CO.
2999 Payne Avenue
Cleveland, OH 44114
(216) 781-4600
- PARAGON SALES, INC.
780 Charcot Avenue
San Jose, CA 95131
(408) 263-7955
- PREMIER SOURCE DISTRIBUTING
1882 McGaw Avenue
Irvine, CA 92714
(714) 261-2011
- STAR DATA, INC.
4021 N. 30th Street, Suite 4
Phoenix, AZ 85016
(602) 955-9233
- SYSPRINT, INC.
7777 S. Central Expressway, Suite 2A
Richardson, TX 75080
(214) 689-3666
- TRANSALASKA DATA SYSTEMS, INC.
200 Center Court
Anchorage, AK 99502
(907) 561-1776
- ... Or these Toshiba Regional Offices:
- TOSHIBA AMERICA, INC.
177 Madison Avenue
Post Office Box 2331R
Morristown, NJ 07960
(201) 326-9777
- TOSHIBA AMERICA, INC.
662 Office Parkway
The Colonnade Building
St. Louis, MO 63141
(314) 991-0751
- TOSHIBA AMERICA, Inc.
2555 Cumberland Parkway, Suite 285
Atlanta, GA 30339
(404) 434-3891
- TOSHIBA AMERICA, INC.
18017 Sky Park Circle
Suites P and Q
Irvine, CA 92714
(714) 250-0151

In Touch with Tomorrow

TOSHIBA

Circle 476 on inquiry card.



Nothing shows off your IBM PC™ like Toshiba's P1350 printer.

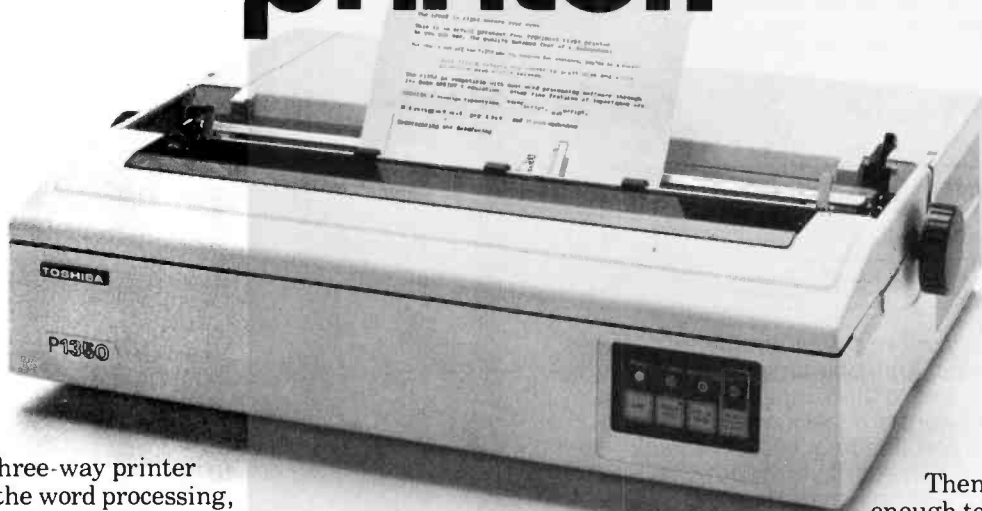

Now there's one three-way printer that fully equals the word processing, data and graphics capacity of your IBM PC: Toshiba's P1350.

But the P1350 is more than compatible with PC hardware. It will print programs like Lotus 1-2-3 data processing and graphics output with remarkable character definition.*

For even more flexibility, the Toshiba P1350 with Qume SPRINT 5 emulation handles all popular word processing programs. Under software command, the P1350 will print high-speed drafts or switch to letter-quality text and graphics.

The innovation behind this three-in-one flexibility is Toshiba's print head. Pin diameter has been reduced to just eight mils. And the number of

pins in the print head has been increased to 24.

The result is a superior 360 by 180 dot-per-inch density pattern in the text mode. Instead of spinning your wheels at 40 cps, the P1350 produces letter-quality printing at 100 cps. In its draft mode, Toshiba's P1350 can accelerate up to 192 cps.

When it comes to graphics, the P1350 really shows its stuff. Whatever your computer displays, Toshiba's P1350 prints. With astonishingly clear definition. And extra-fine reproduction that can only come from a print head capable of 200 million impressions and exclusive 180 by 180 dot-per-inch graphics density pattern.

Then, if that's not enough to pique your interest, the P1350 also

features three different fonts. Variable pitch. Subscripts, superscripts and underlining without the need of a second pass. A super-reliable, optional sheet feeder. And more.

So show off your IBM. OR ANY OTHER PERSONAL COMPUTER. With the superior quality and flexibility of Toshiba's spectacular P1350 printer.

Distributors on the adjacent list make it easy to find the P1350. Or get more information by calling, toll-free, 1-800-457-7777.

*IBM PC to P1350 graphics utilizes PaperScreen and color graphics adapter. IBM PC is a Trademark of International Business Machines. Lotus and 1-2-3 are Trademarks of Lotus Development Corporation. ©1983 Toshiba America, Inc.

In Touch with Tomorrow

TOSHIBA

Information Systems Division, TOSHIBA AMERICA, INC.

We think you're calculating enough to

And we've devised a little test to prove it. All you have to do is compare our PC-8200's specs with the specs for Radio Shack's Model 100 or the HP-75. For someone who's savvy enough about computers to read this magazine, you shouldn't have any trouble picking the best one. So here goes:

	NEC	Radio Shack	Hewlett-Packard
Price	\$799*	\$799	\$995
RAM/ROM	16K/32K	8K/32K	16K/48K
RAM Expandability (Internal/External)	To 96K (64K/32K)	To 32K (32K/none)	To 24K (24K/none)
Free bundled software	Yes	No	No
Function keys	10	8	0
RAM cartridges	Yes	No	No
Bar Code Reader, RS232, Parallel Port, Cassette Port	Yes	Yes	Not Standard
Floppy Disk and SIO Port, Cursor Cluster	Yes	No	Not Standard

*Includes perpetual clock calendar. NiCad battery pack, AC adapter charger optional. The PC-8200 is a battery-operated CMOS-based system.

It all boils down to more power and better features for the same price. And, of course, more software—14 FREE programs to start, including linear forecasting and word processing.

The PC-8200 portable from NEC. We think you should be impressed. If you're not, maybe you picked up the wrong magazine.

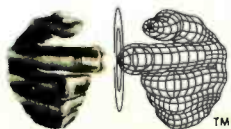

Productivity at your fingertips

NEC

**NEC Home Electronics (U.S.A.), Inc.
Personal Computer Division**

1401 Estes Avenue
Elk Grove Village, IL 60007

NEC Corporation, Tokyo, Japan

Circle 325 on inquiry card.



get more computer for your money.



NEC PC-8201A

LOW BATTERY

Unit shown actual size.

Announcing The best 6502 Assembler in the World

ORCA/M™

Now. The kind of high-level support you'd only expect to find on a main frame.

ORCA/M (Hayden's *Object Relocatable Code Assembler for Micros*) lets you develop sophisticated applications with the speed and ease of a high-level language, yet retain the control and efficiency that only assembly language can give.

Here's what ORCA/M gives you:

The Assembler

Macro language features:

- Conditional assembly of source and macro files
- Separate source and macro files
- Nestable macros
- Parameter mid-string and string search functions
- Symbolic parameter assignment
- Numeric, string, and boolean type parameters
- Parameter subscripting
- Global communication between macros
- Macro expansion loop control
- Count, length and type parameter-attribute functions

Extensive Macro Libraries

Memory Constant Declarations:

- Integer
- Character
- Four-byte Integer
- Hexadecimal
- Floating Point

Relocatable object module generation

Fast assembly directly to disk

Program segmentation:

- Selectively assembly individual subroutines
- Global and local scope of symbols

The Linker

Produce executable binary files from relocatable object modules

Link routines from library files

Link subroutine re-assemblies

Define a new origin for previously assembled code

Invoke at assembly time or by command

Subroutine libraries:

- Floating point and double-precision routines
- Transcendental functions
- Hi- and lo-res graphics
- Multiple-precision integer math
- Input and output

The Editor

Co-resident screen editor:

- Global search and replace
 - Block move
 - Entry of non-keyboard characters
- Supports lower case adapters and shift-key modification**

80-column: horizontal scrolling with 40-column displays

The System

Monitor: transparent control of system from one command level

Extended Disk Commands:

- File copy
- File undelete
- Catalog sort
- Wildcard filenames

Disk ZAP: Built-in disk sector editor

Optimized DOS 3.3 compatible operating system

Operating system interface:

- Supports a variety of configurations
- User-modifiable to allow linkage of custom drivers for peripherals

64k RAM supported, 48k required

This unique array of features and functions speaks for itself: the power of ORCA is unsurpassed.

All features are documented clearly and extensively. Source listings for the subroutine and macro libraries, as well as the operating system, are included.

ORCA. If you're serious about developing 6502 software, it's the one to have.

Available from your local dealer, or call:

800-343-1218
(In MA call 617-937-0200)
ORCA/M: 21609
Apple II or IIe disk, 48k, DOS 3.3
Two drives and 64k recommended

Introductory Price: \$99.95

\$149.95

After September 30, 1983

ORCA/M is now also the best 65C02 assembler, supporting all 27 new opcodes. New hardware support includes the IIe 80 column board and disk emulators for the Legend™ 128K card and IIe extended memory card.

HAYDEN SOFTWARE

Talker

A routine developed for Radio Shack's TRS-80 and Votrax's Type-N-Talk makes writing talking programs easier

by Heyward S. Williams

Writing a talking program is simple if you can use the PRINT and INPUT statements to automatically transfer information to the speech synthesizer. Talker is a keyboard and video-intercept routine that performs this function for the TRS-80 and the Votrax Type-N-Talk voice synthesizer. Although vocal programs are useful in many areas, I wrote this utility routine specifically because I became involved with writing programs for the visually handicapped.

I began work on Talker in 1981 when my wife, Suzanne, lost her sight from a combination of neurovascular rubeosis and retinopathy.

During her rehabilitation, we searched for better ways to handle everyday problems that confront a blind person, such as writing letters and finding addresses or recipes. There was little hope that Suzanne could return to her profession in retailing if she could not access the data she needed to perform her job.

To help solve these problems, I began an investigation of voice synthesizers that would enable Suzanne to use our TRS-80. The only synthesizers available at the time had specific vocabularies, which limited them in our application. One unit, the Sweet Talker from Micromint

Inc., provided its host computer with a software-resident text-to-speech capability and seemed to be the best solution. Unfortunately, it ran only on an Apple II, and because I had already spent several lifetimes learning the idiosyncrasies of my TRS-80, I was hesitant to change machines. Then Votrax Inc. introduced the Type-N-Talk. This unit uses an RS-232C interface and includes a microprocessor programmed to internally execute a text-to-speech algorithm that simplifies the job of writing voice-output programs. Although it is somewhat primitive and occasionally amuses us with original pronunciations, it is reasonably priced and adequately fulfills our requirements.

The first program I wrote for the Type-N-Talk was a typing review and exercise routine that served to overcome Suzanne's mild case of "computerphobia" and familiarize me with the requirements of the synthesizer. Written in machine language, the program is relatively simple.

Next came a more ambitious project: I wrote a simple word-processing program or, as we call it, the Friendly Letter Writer. Although this program is also written in machine language, by the time I had it almost

finished I was convinced that I needed to find a way to write future programs in BASIC if I hoped to ever get them done.

Sending text to the synthesizer from BASIC is not difficult, but the task does require extra lines. This constraint was undesirable because I wanted to use commercially available programs with little or no modification. Back I went to my editor-assembler to write a machine-language program that would make programming spoken text easier. The result, presented here, is called Talker.

Features

Talker has many useful features:

- It is transparent to the keyboard and video routines so that normal BASIC commands such as INKEY\$ and PRINT can transfer information to the synthesizer as well as execute their normal functions
- It is written in machine language to minimize processing delay
- It repeats each key as it is pressed
- It reads whatever is written to the video display
- A character immediately sent to the video display from the keyboard is not repeated

- It pronounces punctuation marks and, if they are returned from the keyboard, the control codes (the Type-'N-Talk unit alone does not pronounce punctuation or control codes)
- It skips redundant spaces, which are often used to position titles on the display but which would result in excessive delays in the spoken text
- The text transmitted to the Type-'N-Talk is spoken if a carriage-return character or two consecutive spaces are encountered
- The spoken response can be turned off and on from the keyboard or by sending special characters to the display
- Talker can be put into a mode in which it ignores some punctuation by sending special characters to the display
- It automatically relocates itself to the end of high memory, resets the high-memory pointer, changes the keyboard and video-driver vectors, and jumps to BASIC or returns to the disk operating system (DOS)
- The program operates without modification on Model I or Model III computers
- It occupies less than ½K byte of memory

•It is compatible with Level II BASIC, TRSDOS, and NEWDOS

Talker operates best with a disk system because of the ease with which some programs can be implemented, but a disk system is not necessary.

In one mode, Talker ignores some punctuation by sending special characters to the display.

Hardware and Setup

To run Talker, you'll need an RS-232C interface board to enable the Type-'N-Talk unit to receive information from the computer. These boards are available from Radio Shack (part numbers 26-1145 and AXX0511 for Models I and III, respectively). You must modify the RS-232C connection to work with the Votrax unit, however, because this application requires only the RECEIVE-ONLY mode (the Votrax unit provides more modes than are neces-

sary). To implement the RECEIVE-ONLY mode, the Ground Return lines (pins 1 and 7) and the Ready to Transmit (RTS, pin 5) lines must connect to the TRS-80. The next step involves resolution of the standard problem associated with RS-232C transmissions: the proper connection of the Transmit Data and Receive Data lines. It seems that every piece of equipment designed considers itself the controller, asserting that pin 2 on its connector is the Transmit Data line and expecting that everything else will dutifully receive data on this line. The Type-'N-Talk is no exception to this, and to make it work properly, pin 2 on the TRS-80 connector must go to pin 3 on the synthesizer. (In theory, you could put the COMM/TERM switch on the Model I's RS-232C board in the COMM position to solve this problem; the Model III doesn't have this switch.) Finally, pins 4, 8, and 20 on the Type-'N-Talk must connect for proper operation. I used two RS-232C connectors (Radio Shack 276-1547 male and 276-1548 female) separated by ¾-inch spacers (from Radio Shack's 64-3024 assortment) and held together by 1-inch 4-40 machine screws to make a jumper. Figure 1 shows the necessary connections. The female connector plugs into the RS-232C cable, and the male connector plugs into the Votrax unit. For a Model I system, the COMM/TERM switch must be in the TERM position. The sense switch settings on the Model I RS-232C board are not important because the bps (bits-per-second) rate is set in the software.

The Type-'N-Talk can retransmit data it receives to other units (modems and printers) on the same RS-232C line. I disabled this feature to improve throughput because my printer has a parallel interface. I have not investigated whether this program can run both the Votrax unit and a printer on the same interface.

Set the Baud Rate switches on the back of the Type-'N-Talk for 9600 bps (switches 1 through 7 up, switch 8 down), the rate selected in the software.

You'll need an external speaker and, to connect it to the synthesizer,

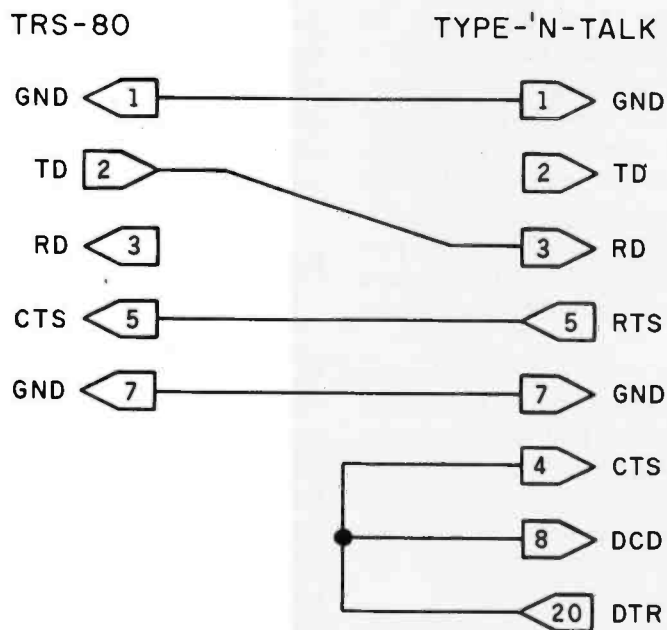

RS-232C CONNECTIONS

Figure 1: A schematic illustrating the RS-232C connections between a TRS-80 computer and a Type-'N-Talk voice synthesizer.

VISUAL 300/330.

Excellence in Ergonomics, Emulations and Economics.

Both the VISUAL 300 and VISUAL 330 combine VISUAL ergonomic elegance with excellent emulation capability.

For example, the VISUAL 300 complies to the ANSI X3.64 standard and is protocol-compatible with DEC VT100/VT52® terminals. And the VISUAL 330 emulates the DEC VT52, Lear Siegler ADM-3A,™ Data General D200, and Hazeltine 1500.

Nothing compares to these VISUAL terminals when it comes to ergonomics. They are designed in lightweight plastic and can easily be swiveled and tilted for maximum operator comfort. A "menu-style" set-up mode eliminates all cumbersome switches. Other human design features include:

- 12" or 14" non-glare screen, available in green or white phosphor
- High density 7 x 9 dot matrix characters; 7 x 11 in lower case
- 25th status line
- Detached keyboard, with coil cable
- Sculptured keycaps with matte finish for low glare
- N-Key rollover

- Audible keyclick, user enabled
 - Jump, or 2-speed smooth scrolling
- The versatile VISUAL 300 and 330 offer a package of standard features unmatched by any terminal in their class:
- Block and character transmission
 - 12 user-programmable non-volatile function keys, each capable of storing 32 characters
 - Blink, underline, reverse, bold and blank video attributes require no display space
 - Line-drawing character set
 - Split screen
 - Full editing
 - Programmable non-volatile columnar tabbing, or field tabbing, forward and backward

The U.L. listed VISUAL 300 and 330 exceed FCC Class A requirements and U.S. Government standards for X-ray emissions.

All this at surprisingly low prices. Call for details on the VISUAL 300 and 330—the flexible terminals.

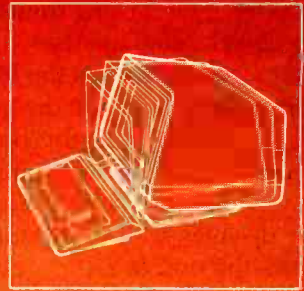

Tilt: 10° forward, 15° backward



Swivel: 270°



Service available in principal cities through Sorbus Service, Division of Management Assistance, Inc.

VISUAL

 See for yourself

Visual Technology Incorporated
540 Main Street, Tewksbury, MA 01876
Telephone (617) 851-5000. Telex 951-539

Circle 498 on inquiry card.

www.americanradiohistory.com

a cable with a miniature phone plug on one end and whatever matches the speaker on the other.

Commands and Operation

You can select four Type-N-Talk operating modes using control codes. The Talker program uses only one mode. The first causes the phoneme codes corresponding to the input text to be transmitted to the host computer. The Talker implementation does not use this mode, therefore the unit disables it. The second mode causes the unit to retransmit the input text on the RS-232C lines to other peripherals in a daisy-chain configuration. The Talker program disables this function. The next mode, also disabled in this application, spells out all consecutive capital letters. Finally, an internal timer causes any text in the buffer to be spoken if more than approximately four seconds have elapsed since the last character was received. This mode is left operational and is used by Talker.

The most important command that the Votrax unit recognizes is the carriage

return (hexadecimal 0D, decimal 13). This command causes any text in the buffer to be spoken and is used extensively by the Talker program.

Within the Type-N-Talk, an internal 750-character buffer stores incoming text. If it is filled before a carriage return is received, the unit stops accepting transmissions and speaks the text. Recognizable characters are limited to uppercase and lowercase characters and numbers. The unit ignores punctuation and control characters; they must be translated by the program.

Talker does not use the phonetic programming modes of the Type-N-Talk unit; the text-to-speech algorithm is adequate.

The Driver Vectors

The key to program operation lies in the use of vector addressing to locate the keyboard and video-display driver routines in the TRS-80. A block of RAM (random-access read/write memory) is set aside for information about the keyboard and the

display. The RAM locations in the block are initialized when the computer is first turned on or reset; the locations contain the information listed in table 1 on page 452.

The RAM locations allow execution of appropriate subroutines. For example, if a PRINT statement is encountered, the BASIC interpreter calls a subroutine that goes to hexadecimal RAM 401E through 401F (decimal 16414 through 16415) to find the address of the driver that will print the specified character on the display and then jumps to that address. It isn't difficult, therefore, to insert the Talker routine in series with the display driver. The original address is taken from the vector location hexadecimal 401E through 401F and saved as the exit address from Talker. The address of Talker is written in its place. When the display driver is called, the program goes first to the Talker routine, then on to the original driver, and finally back to the host program.

Essentially the same thing happens to the keyboard driver except that the

FREE SHIPPING

SYSTEM #1
OUR LEAST EXPENSIVE WORD PROCESSING SYSTEM
 Pied Piper • Comrex CR-2 • Zenith ZVM-123 Monitor • Perfect Speller • Perfect Calc • Word Processor • Perfect Filler
\$1549

SYSTEM #2
OUR LEAST EXPENSIVE IBM LOOK-A-LIKE
 Sanyo MBC-555 2 Drive Computer • Zenith ZVM-123 Monitor • Word Processor • Spread Sheet • MS-DOS
\$1119
 • Sanyo Basic
 (Above With One Disk Drive \$810)

<p>PRINTERS</p> <p>C. ITOH</p> <p>Prowriter 8510 \$345. F-10 Serial or Parallel \$1099.</p> <p>COMREX</p> <p>CR-2 SAVE</p> <p>DIABLO</p> <p>620 RO \$875. 630 RO \$1715.</p> <p>EPSON</p> <p>RX-80 SAVE RX-80 F/T SAVE MX-80 F/T SAVE FX-80 SAVE FX-100 SAVE</p> <p>JUKI</p> <p>6100 \$480.</p> <p>NEC</p> <p>8023A \$385. 3510 \$1370. 3550 \$1715.</p> <p>STAR MICRONICS</p> <p>Gemini 10X & 15X SAVE Delta SAVE</p>	<p>PRINTERS</p> <p>OKIDATA</p> <p>82A \$390. 83A \$635. 84P \$980. 84S \$1065. 92 \$495. 93 \$840.</p> <p>TALLY</p> <p>MT 160L w/tractors SAVE MT 180L w/tractors SAVE Spirit 80 SAVE</p> <p>TOSHIBA</p> <p>1350 Serial or Parallel \$1460.</p> <p>TRANSTAR</p> <p>130P \$675. 120P \$450. T315 \$450.</p> <p>TERMINALS</p> <p>TELEVIDEO</p> <p>910 \$470. 910+ \$555. 925 \$705. 950 \$905. 970 \$980.</p>	<p>COMPUTERS</p> <p>PIED PIPER</p> <p>Communication I \$975.</p> <p>TELEVIDEO</p> <p>803 \$1825.</p> <p>SANYO</p> <p>MBC 550 \$715. MBC 555 \$1025.</p> <p>MODEMS</p> <p>HAYES</p> <p>1200 \$490 300 \$205</p> <p style="font-size: 0.8em;">Prices reflect 3% to 5% cash discount. Product shipped in factory cartons with manufacturer's warranty. Free shipping is on UPS ground only. Prices & availability subject to change without notice. Send cashier's check or money order...all other checks will delay shipping two weeks.</p>
---	---	--

SILICON SPECIALTIES
 2034 WEST SOUTHERN
 MESA, ARIZONA 85202
 602-969-0921

Sakata COLOR MONITORS

... we promise performance



SAKATA offers fine quality CRT DISPLAY MONITORS which are compatible with IBM, APPLE, ATARI 800, NEC and other fine personal computers.

Unusually attractive design with neutral color will enhance the appearance, provide unexcelled quality performance. Illustrated Model SC-100 is 13" **COLOR** Display Monitor with linear circuitry, composite color and a host of other quality features.

Also available: Model SG-1000 . . . 12" monochrome, high resolution CRT MONITOR. Model SC-200 . . . 13" RGB high resolution **COLOR** CRT MONITOR. Model SC-300 . . . 13" RGB, super high resolution **COLOR** CRT MONITOR. Priced below competition—if there is any.

SAKATA CRT MONITORS are available wherever personal computers are sold or write for technical and illustrated literature and prices.



SAKATA SC-100 COMPATIBILITY CHART

COMPUTER	SC-100 COLOR
APPLE II	✓
APPLE III	
ATARI-800	✓
COMMODORE-64	✓
IBM-PC	✓
NEC-PC	✓
OSBORNE	✓
TI-99	✓
VIC-20	✓

NOTE: ON CERTAIN COMPUTERS
ADAPTER CABLE REQUIRED.

SAKATA U.S.A. CORPORATION
651 Bonnie Lane, Elk Grove Village, IL 60007
(312) 593-3211/800-323-6647 (outside Illinois)

"SAKATA . . . serving industry worldwide . . . since 1896"

Location	Description
4015 hexadecimal 16405	Start of keyboard block—driver type
4016 hexadecimal 16406	Driver address—least significant byte
4017 hexadecimal 16407	Driver address—most significant byte
401D hexadecimal 16413	Start of video block—driver type
401E hexadecimal 16414	Driver address—least significant byte
401F hexadecimal 16415	Driver address—most significant byte

Table 1: *The special codes used to control Talker.*

Decimal	Hexadecimal	ASCII	Translated
00	00	NULL	Ignored
01	01	SOH	Break (keyboard only)
04	04	EOT	Control — Turns off punctuation
05	05	ENQ	Control — Turns on punctuation
06	06	ACK	Control — Turns Talker off
07	07	BEL	Control — Turns Talker on
08	08	BS	Back (keyboard only)
09	09	HT	Tab (keyboard only)
10	0A	LF	Down (keyboard only)
10	0D	CR	Sends carriage return
24	18	CAN	Shift back (keyboard only)
25	19	EM	Shift tab (keyboard only)
27	1B	ESC	Shift up (keyboard only)
31	1F	US	Clear (keyboard only)
32	20	SP	Space (keyboard only)
33	21	!	Exclamation *
34	22	"	Quote *
35	23	#	Number
36	24	\$	Dollar
37	25	%	Percent
38	26	&	And
39	27	'	Apostrophe *
40	28	(Paran *
41	29)	Close paran *
42	2A	*	Asterisk *
43	2B	+	Plus
44	2C	,	Comma *
45	2D	-	Minus * (could be dash)
46	2E	.	Point * (could be period)
47	2F	/	Slash
48-57	30-39	0-9	Numbers 1 through 9
58	3A	:	Colon *
59	3B	;	Semicolon *
60	3C	<	Less
61	3D	=	Equals
62	3E	>	Greater
63	3F	?	Question *
64	40	@	At
65-90	41-5A	A-Z	Letters A through Z
91	5B	_	Up *
92-95	5C-5F		Ignored
96	60		Control — Turns Talker off (keyboard)
97-122	61-7A	a-z	Letters a through z
123-255	7B-FF		Ignored

* Not spoken if punctuation off

Table 2: *The characters recognized as valid by Talker and their translations. The spelling errors correct pronunciation problems in the voice synthesizer.*

Talker program must intercept the character after it has been generated by the keyboard. Here the Talker program calls the original keyboard driver. After the original keyboard driver has done its job, it returns to the Talker program, which performs its magic and returns to the host program.

Philosophy

Because the program was written for a visually impaired person who was not computer-oriented, simplicity and ease of use were important.

Each key on the keyboard, including all the punctuation marks and control codes (see table 2), is spoken as it is pressed. Although more characters can be displayed on the video screen, only those that correspond to the keyboard are spoken, keeping the number of characters to a minimum. To make the visualization process even easier and to increase the speed at which the text can be read, the operator has the option of preventing some punctuation marks from being spoken when they are displayed on the video screen. Imagine (comma), if you can (comma), how advantageous this can be (exclamation)!

Ideally, turning the computer on should automatically load the program to eliminate any technical decisions that might be confusing to a blind operator. The computer operating system becomes transparent to the user, who can concentrate on the requirements of a specific applications program. Incidentally, I have found that this philosophy is equally valuable when writing programs for people who are not handicapped by anything but their own fear of computers. In fact, I often use it on programs written for my own use, simply because I am too lazy to type in all the required statements to get the program to run time after time.

If the program is not being used by a visually handicapped person, the character set can be expanded, and normal modes of loading and executing programs can be used.

Loading

I was able to implement the automatic loading system easily using a

UNBELIEVABLE!

XCOMP sat down to design a truly distributed IBM network so versatile and complete that it would satisfy any user's needs.

It seems too good to be true, but we did it!

X-NET is so advanced that it can only be imitated. It has all the features of standard networks and many more. And, because it is not dependent on a central file server you save the high cost of that hardware.

Call our sales department today for complete details on X-NET. The exclusive network of PC-DOS 2.0!

X-NET

A Network Superset of PC-DOS 2.0

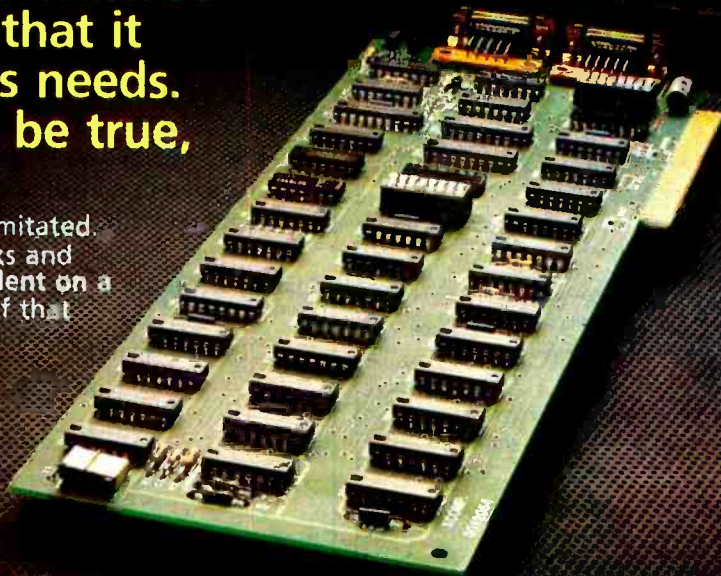

Other quality products available from XCOMP.

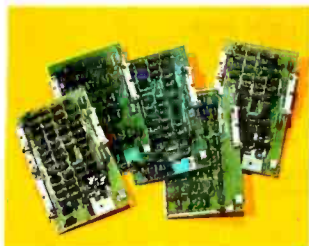

CONTROLLERS

XCOMP manufactures a complete line of controllers for all popular drives. The X/R Series is a controller for 3 to 300 megabyte drives.

We also produce a \$100 controller package. A microprogrammable data board is common to each package and operates with a second drive interface board. Buffer size is 256 bytes, with disk data rate up to 10MHz.



HARD DISK SUB-SYSTEMS

10 megabyte and 16 megabyte hard disk sub-systems for the IBM PC, Apple II and III and nearly all popular personal computers.

XCOMP sub-systems are 2 to 3 times faster than many of the competition's and come complete with our extensive software.

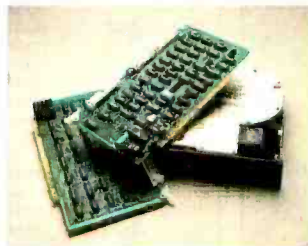

PACKAGE DEALS

Exceptional prices on 10 and 16 megabyte formatted drives and controllers. The ST/S for S100 computers and the ST/R for single board computers. An optional Z-80 adapter allows for simple plug-in convenience. Optional equipment includes software, cables and cabinetry.



THE TOASTER

THE TOASTER is a hard disk sub-system containing TWO REMOVABLE 3.9", 5 megabyte cartridges. THE TOASTER provides unlimited storage and convenient back-up with total portability. Speed and convenience for simple disk.

THANK YOU FOR YOUR OVERWHELMING RESPONSE!

We are substantially back-ordered on TOASTERS. We appreciate your patience!

Circle 516 on inquiry card.

Apple, Apple II and Apple III are trademarks of Apple Computer, Inc.
IBM and IBM PC are trademarks of International Business Machines Corporation



© 1983, XCOMP, Inc.

XCOMP, Inc., 7566 Trade Street, San Diego, CA 92121, (619) 271-8730, Telex 182786

RS-232

DATA ACQUISITION

Control & Measurement



Starbuck Model 8232

A general purpose real-world interface: connects to ANY computer or terminal via RS-232

TYPICAL APPLICATIONS:

- Use with printing terminal: create low-cost data logger
- Use with modem and phone for remote acquisition & control
- Capture data bursts for subsequent analysis/plotting
- Monitor experiments; transfer data daily to main computer

FEATURES:

- 8 analog inputs, 0-5 VDC
- 8 digital input channels
- 8 opto-isolated outputs
- All inputs and outputs fully protected to withstand abuse
- 8 bit (0.4%) analog accuracy
- On-board 2000 point buffer
- Up to 5000 analog readings/s
- Triggered acquisition
- Units may be chained for extra channels
- Controlled by ASCII strings
- Application manual details interfaces for common sensors
- Applications engineer on call
- THRIFTY PRICE: \$540. complete! Applications manual only: \$5. TRS-80 version also available



PO Box 24, Newton, MA 02162
(617) 237-7695

Dealer and OEM inquiries welcome

disk system and NEWDOS/80 version 2.0. I disabled the date and time prompts using the NEWDOS SYSTEM command and set the AUTO command to run TALKER/CMD. When the computer is turned on, the program relocates itself, performs some housekeeping to set up the interfaces, exits to BASIC, and starts executing a menu program. This procedure works equally well with Model I and Model III TRS-80 computers.

When I decided to write this article, I realized that I would have to try the program with TRSDOS. I found

my old Model I TRSDOS 2.3 disk and discovered that I could use the AUTO command, which loads and executes the Talker program. However, when the relocation routine exits to DOS, the operator must type BASIC, answer the NUMBER OF FILES? and MEMORY SIZE? questions, and then select a specific program to run. But don't despair; keep reading and you will find a version of the Talker program that simplifies this operation.

The same result can be accomplished with TRSDOS on the Model III; however, the DATE and TIME questions must be answered before

Text continued on page 466

Listing 1: The Talker program and symbol table.

```

00100 ;RELOCATABLE TALKING INTERCEPT PROGRAM (TALKER)
00110 ;
7000 00120 ORG 7000H
00130 ;
7000 20 00140 DEFM ' 14 APRIL 1983 '
00150 ;
00160 ; ROUTINE TO RELOCATE PROGRAM TO HIGH MEMORY
00170 ;
00180 ; ONCE THE PROGRAM HAS BEEN RELOCATED, THIS PART OF THE
00190 ; PROGRAM IS DISCARDED
00200 ;
4049 00210 HIMEM1 EQU 4049H ;MODEL I END OF MEM ADDR
4411 00220 HIMEM3 EQU 4411H ;MODEL III END OF MEM ADDR
4016 00230 KBDADR EQU 4016H ;KEYBOARD DRIVER VECTOR LOCATION
401E 00240 CRTADR EQU 401EH ;DISPLAY DRIVER VECTOR LOCATION
00250 ;
00260 ; FIRST THE DISPLAY & KEYBOARD DRIVER ADDRESSES ARE
00270 ; TRANSFERRED FROM THE VECTOR LOCATIONS INTO THE PROGRAM
00280 ;
7010 2A1E40 00290 START LD HL,(CRTADR) ;DISPLAY DRIVER VECTOR
7013 225972 00300 LD (CRTRET),HL
00310 ;
7016 2A1640 00320 LD HL,(KBDADR) ;KEYBOARD DRIVER VECTOR
7019 220172 00330 LD (KBDRET),HL
00340 ;
00350 ; NEXT THE RS-232 PORT IS INITIALIZED
00360 ;
701C 3EEE 00370 LD A,0EEH ;9600 BAUD
701E D3EB 00380 OUT (0EBH),A ;RST UART
7020 D3E9 00390 OUT (0E9H),A ;SET BAUD RATE
7022 3E6C 00400 LD -A,6CH
7024 D3EA 00410 OUT (0EAH),A ;SET CONTROL REGISTER
00420 ;
00430 ;THE RETRANSMISSION MODE OF THE VOTRAX UNIT IS TURNED OFF
00440 ;
7026 3E1B 00450 LD A,1BH ;TO TURN OFF ECHO MODE
7028 CDCB72 00460 CALL SEND ;SEND CHARACTERS 1BH 14H
702B 3E14 00470 LD A,14H
702D CDCB72 00480 CALL SEND
00490 ;
00500 ; NOW THE LENGTH OF THE PROGRAM IS DETERMINED
00510 ; AND HIGH MEMORY IS CHANGED
00520 ;
7030 2A4940 00530 LD HL,(HIMEM1) ;MODEL I END OF MEM ADDR
7033 3A5000 00540 LD A,(0050H) ;CHECK MOD I OR MOD III
7036 FE0D 00550 CP ODH
7038 2B03 00560 JR Z,SET1 ;JUMP IF MODEL I
703A 2A1144 00570 LD HL,(HIMEM3) ;MODEL III END OF MEM ADDR
00580 ;
703D 01B401 00590 SET1 LD BC,LAST-BEGIN ;LENGTH OF PROGRAM
7040 B7 00600 OR A ;CLEAR CARRY
7041 ED42 00610 SBC HL,BC
00620 ;
7043 FE0D 00630 CP ODH ;CHECK MODEL I OR MODEL III
7045 2B05 00640 JR Z,SET2 ;JUMP IF MODEL I
7047 221144 00650 LD (HIMEM3),HL ;SET MODEL III HIGH MEM
704A 1B03 00660 JR SET3
704C 224940 00670 SET2 LD (HIMEM1),HL ;SET MODEL I HIGH MEM
704F 23 00690 SET3 INC HL ;POINT HL @ NEW START ADDR OF PROG
7050 E5 00700 PUSH HL ;SAVE NEW START ADDRESS
00710 ;
00720 ; DETERMINE NUMBER OF BYTES BETWEEN THE PRESENT LOCATION
00730 ; OF THE PROGRAM & THE ADDRESS AT WHICH IT WILL BE WHEN
00740 ; IT IS RELOCATED
00750 ;
7051 110072 00760 LD DE,BEGIN ;PRESENT ADDR 1ST BYTE OF PROG
7054 AF 00770 XOR A

```

Listing 1 continued on page 456

How to make your Apple run 3½ times faster.



Just plug in the Accelerator II® and watch your Apple® II or II Plus take off.

Imagine running VisiCalc®, DB Master®, Applesoft, Apple Fortran or Pascal without long delays. With the Titan Accelerator II, your Apple II or II Plus runs these programs a true 3½ times faster. The Accelerator II also runs your Franklin, Basis and other Apple II compatibles 3½ times faster. This faster computer response time means less waiting for you and an increase in your productivity.

This Titan exclusive has its own fast 6502 processor, 64K of high-speed memory, and built-in fast language card. It is transparent to your software and is hardware compatible with most standard peripherals. And you can turn it off from the keyboard to run your Apple at regular speed.

Find out how to run faster and increase your productivity without breathing hard. For information on the Accelerator II and other Titan microcomputer products, see your computer dealer or contact: Titan Technologies, Inc., P.O. Box 8050, 3990 Varsity Dr., Ann Arbor, MI 48107; Telephone (313) 973-8422.



Attention dealers. Ask us about our special demonstrator unit offer.

Sales and marketing by The MARKETING RESOURCE GROUP, Costa Mesa, CA.

Apple is a registered trademark of Apple Computer, Inc. VisiCalc is a registered trademark of VisiCorp, Inc. DB Master is a registered trademark of Stoneware, Inc.

SPECTACULAR OFFERS

wabash

6 YEAR WARRANTY

M11	5 1/4"	SINGLE SIDE SINGLE DENSITY	1.49*
M13	5 1/4"	SINGLE SIDE SINGLE DENSITY	1.89*
M14	5 1/4"	DOUBLE SIDE DOUBLE DENSITY	2.79*
M16	5 1/4"	DOUBLE SIDE QUAD DENSITY	4.19*
F111	8"	SINGLE SIDE SINGLE DENSITY	1.89*
F1312	8"	SINGLE SIDE DOUBLE DENSITY	2.39*
F144	8"	DOUBLE SIDE DOUBLE DENSITY	2.99*

maxell

LIFETIME WARRANTY

MD1	5 1/4"	SINGLE SIDE DOUBLE DENSITY	2.29*
FD1-128	8"	SINGLE SIDE DOUBLE DENSITY	3.60*

BASF

2 YEAR WARRANTY

54968	5 1/4"	ss,dd	1.79*
53428	8"	ss,sd	1.89*

BASF

LIFETIME WARRANTY

54974	5 1/4"	ss,dd	2.19*
54998	8"	ss,sd	2.29*

TDK

LIFETIME WARRANTY

2501	5 1/4"	ss,dd	2.49*
2801	8"	ss,dd	3.90*

SENTINEL

LIFETIME WARRANTY

5S-11	5 1/4"	ss,dd	1.73*
8S-11	8"	ss,sd	2.14*

WE ALSO STOCK AT FANTASTIC LOW PRICES

Memorex

3M

Dynaflex

ULTRA

Flippies, Tapes, Data Cartridges, Data Cassettes, and Disk Picks

* QUANTITY 100. SMALLER QUANTITIES ADD 5%

DISK DRIVE HEAD CLEANING KITS
5 1/4"
15.95

C-10 CASSETTES
Get 8 cassettes, and Cassette/8 Library Album 8.00

SNAP-IT POWER CENTER
Turn one outlet into six!
Power Surge Control
RFI Filtration
15 Amp Circuit Breaker 59.95

LIBRARY CASES
8" Kas-sette/10 2.99
5 1/4" Mini Kas-sette/10 2.49

BOOK VALUES

FULL SELECTION, DISCOUNT PRICES

on hundreds of titles published by ALFRED, HAYDEN, DILITHIUM, SAMS, TAB, MCGRAW HILL and many others.

SOFTWARE

AT FANTASTIC PRICES

SAVE 25% OR MORE on thousands of software packages for all systems, including Business, Language, Engineering, Games, Graphics, Utility, and many more.

• Written purchase orders accepted from governmental agencies and well rated firms for net 30 day billing. • International orders accepted with a 15.00 surcharge for handling, plus shipping charges. • C.O.D. requires a 10% deposit. • We accept Visa, Mastercard, Money Order, and Certified checks. • Checks require bank clearance. • All shipments F.O.B. San Diego. • Minimum shipping and handling 2.00, minimum order 10.00. • California residents add 6% sales tax. Prices and terms subject to change without notice. • All sales subject to availability, acceptance, and verification. • All sales are final. • Satisfaction guaranteed or full refund.

We also offer printer ribbons, printwheels, type elements, equipment covers, power consoles, paper supplies, storage and filing equipment, furniture and many other accessories for word and data processing systems. Write for our free catalog.

Orders Only
800-854-1555
Information
619-268-3537

ABC

DATA PRODUCTS

Modern Hotline (Anytime) 619-268-4488
Exclusive Monthly Specials
ITT TELEX 4992217
8668 CLAIREMONT MESA BLVD
SAN DIEGO, CALIFORNIA 92123

Listing 1 continued:

7055 ED52	00780	SBC	HL,DE	;NEW BEGINNING - PRES BEGINNING
7057 EB	00790	EX	DE,HL	;DIFFERENCE INTO REGISTER DE
	00800 ;			
	00810 ;			NEXT THE VARIOUS ABSOLUTE ADDRESSES IN THE PROGRAM ARE
	00820 ;			ADJUSTED TO REFLECT THE NEW LOCATION
	00830 ;			
7058 21B372	00840	LD	HL,FIND	
705B 19	00850	ADD	HL,DE	
705C 221A72	00860	LD	(F11+1),HL	
	00870 ;			
705F 215B72	00880	LD	HL,DISTLK	
7062 19	00890	ADD	HL,DE	
7063 225472	00900	LD	(CONT+2),HL	
	00910 ;			
7066 21E372	00920	LD	HL,LTRFLG	
7069 19	00930	ADD	HL,DE	
706A 224872	00940	LD	(CONS+1),HL	
	00950 ;			
706D 21DF72	00960	LD	HL,TOGG	
7070 19	00970	ADD	HL,DE	
7071 220772	00980	LD	(S1+1),HL	
7074 223072	00990	LD	(S2+1),HL	
	01000 ;			
7077 21C872	01050	LD	HL,SEND	
707A 19	01060	ADD	HL,DE	
707B 22B472	01070	LD	(T1+1),HL	
	01080 ;			
707E 21C672	01090	LD	HL,CR	
7081 19	01100	ADD	HL,DE	
7082 222272	01110	LD	(T2+1),HL	
	01120 ;			
7085 21C272	01130	LD	HL,SPACE	
7088 19	01140	ADD	HL,DE	
7089 22AF72	01150	LD	(SPKW-2),HL	
	01170 ;			THE NEW KEYBOARD & DISPLAY VECTORS ARE THEN CALCULATED
	01180 ;			AND PUT IN THE NORMAL VECTOR LOCATIONS
	01190 ;			
708C 21D272	01200	LD	HL,TCRT	;DISPLAY ROUTINE
708F 19	01210	ADD	HL,DE	
7090 221E40	01220	LD	(CRTADR),HL	
	01230 ;			
7093 210072	01240	LD	HL,ECHO	;KEYBOARD ROUTINE
7096 19	01250	ADD	HL,DE	
7097 221640	01260	LD	(KBDADR),HL	
	01270 ;			
	01280 ;			FINALLY THE PROGRAM IS TRANSFERED TO THE NEW LOCATION
	01290 ;			
709A D1	01300	POP	DE	;NEW BEGINNING ADDRESS
709B 210072	01310	LD	HL,BEGIN	;OLD BEGINNING ADDRESS
709E EDB0	01320	LDIR		;REG BC STILL HAS LENGTH OF PROG
	01330 ;			
	01340 ;			NOW RETURN TO DOS OR JUMP TO BASIC & RUN A PROGRAM
	01350 ;			
70A0 21A670	01360	LD	HL,BASIC	
70A3 C30544	01370	JP	4405H	;NEWDOS DOS COMMAND MODE
	01380 ;			
70A6 42	01390	BASIC	DEFM	*BASIC 3V, RUN"DATE"*
70BB 0D	01400		DEFB	ODH
	01420 ;			TRSDOS CHAINING ROUTINE
	01430 ;			
	01440 ;			THE NEW KEYBOARD & DISPLAY VECTORS ARE CALCULATED
	01450 ;			AND PUT IN THE NORMAL VECTOR LOCATIONS
	01460 ;			
70B9 21D272	01470	LD	HL,TCRT	;DISPLAY ROUTINE
70BC 19	01480	ADD	HL,DE	
70BD 221E40	01490	LD	(CRTADR),HL	
	01500 ;			
70C0 210072	01510	LD	HL,ECHO	;KEYBOARD ROUTINE
70C3 19	01520	ADD	HL,DE	
70C4 22FB70	01530	LD	(TKBDR),HL	;SAVE FOR FUTURE USE
	01540 ;			
	01550 ;			FINALLY THE PROGRAM IS TRANSFERED TO THE NEW LOCATION
	01560 ;			
70C7 D1	01570	POP	DE	;NEW BEGINNING ADDRESS
70CB 210072	01580	LD	HL,BEGIN	;OLD BEGINNING ADDRESS
70CB EDB0	01590	LDIR		;REG BC STILL HAS LENGTH OF PROG
	01600 ;			
	01610 ;			NOW RETURN TO DOS & CHAIN TO BASIC
	01620 ;			
70CD 21DC70	01630	LD	HL,CHAIN	;SET KBD VECTOR FOR CHAIN
70D0 221640	01640	LD	(KBDADR),HL	
	01650 ;			
70D3 21FA70	01660	LD	HL,COMD	;COMMAND STRING
70D6 22F670	01670	LD	(COMREG),HL	;SAVE HL
70D9 C32D40	01680	JP	402DH	;JUMP TO TRSDOS
	01690 ;			
70DC 2AF670	01700	CHAIN	LD	HL,(COMREG)
70DF 4E	01710	LD	C,(HL)	;COMMAND CHARACTER
70E0 23	01720	INC	HL	;POINT TO NEXT CHARACTER
70E1 22F670	01730	LD	(COMREG),HL	;SAVE NEXT STRING ADDR
70E4 110C71	01740	LD	DE,ECCOMD+1	;END OF COMMAND STRING
70E7 7C	01750	LD	A,H	;TEST FOR END OF COMM STR
70E8 92	01760	SUB	D	
70E9 2002	01770	JR	NZ,CH1	
70EB 7D	01780	LD	A,L	
70EC 93	01790	SUB	E	
70ED 79	01800	CH1	LD	A,C
70EE C0	01810	RET	NZ	;RETURN IF NOT END

Listing 1 continued on page 458



For families who are serious about FUN..

Now, you can get brand-new computer games for families who want *more* than shoot-'em-up space wars with flat stick-figure graphics. These are absorbing one-of-a-kind games that will treat you to the most advanced color animation ever for the Apple® Personal Computer.

Children delight in the bubble-gum colors and cartoon-like animation. Grownups and game connoisseurs are challenged by the expert skills and strategy required to survive to the final rounds.

Look for this new software — created by Optimum Resource, Inc. and distributed by Weekly Reader Family Software — in finer computer stores. Or call toll-free 1-800-852-5000, Dept. AB-40.

Apple II or Apple II+, with 48K and one disk drive. 3.3 DOS, and Apple IIe or Apple III. Keyboard, paddles or Joy stick.

Stickybear, Old Ironsides, Chivalry and Fat City are registered trademarks of Optimum Resource, Inc. Apple and Apple II, II+, IIe and III are registered trademarks of Apple Computer, Inc.

AM13-G23

Circle 517 on inquiry card.



NEW Fat City™
Operate a wrecker to flatten buildings as garbage cans are hurled at you from windows. 9 different towns. Poster, stickers included. Ages 8 to 99. **Only \$39.95**



NEW Stickybear™ Basketbounce
Win points by catching falling bricks, donuts or stars before running out of baskets. 16 rounds. Poster, desk-top mobile, stickers included. Ages 3 to 99. **Only \$39.95**



Old Ironsides™
Thrilling 2-player naval battle. Use the wind, compasses, cannons to outwit your opponent! Detailed graphics recreate true sailing experiences. Poster, Log Book included. Ages 8 to 99. **Only \$39.95**



Stickybear™ Bop
Animated shooting galleries of Stickybears, ducks, planets, more. Pop-up game, poster, stickers included. Ages 3 to 99. **Only \$39.95**



NEW Chivalry™
Unique boardgame and software combination. To rescue the king, play 20 animated games of skill and chance — jousting, tournaments, etc. For 1 to 4 players. Sturdy 21" x 24" gameboard, playing pieces, poster, instructions, strategy hints included. Ages 8 to 99. **Only \$49.95**

Weekly Reader Family Software

A division of Xerox Education Publications
Middletown, CT 06457

MICROXPRESS

DISK DRIVES FOR

IBM · apple · TRS-80 **ZENITH** / HEATH®
AND OTHER PERSONAL/MICROCOMPUTERS



8" THINLINE FLEXIBLE DISK SUBSYSTEM
(SHOWN ABOVE) FULLY ASSEMBLED & TESTED WITH COMPLETE DOCUMENTATION
I-8480* DUAL DRIVE, DOUBLE-SIDED, 2.4MB .. \$1.495
I-8481* SINGLE DRIVE, DOUBLE-SIDED, 1.2MB;
INCL. FILLER PANEL - SECOND DRIVE
CAN BE ADDED LATER 995
*8" FLEXIBLE DISK CONTROLLERS FOR **IBM PC & apple** NO CONTROLLER NEEDED FOR **Zenith/HEATH*** Z-100 Call

5 1/4" FULL HEIGHT INTERNAL MOUNTING FLEXIBLE DISK DRIVES FOR IBM PC & XT, Zenith/HEATH* AND OTHER SMALL COMPUTERS.
GD CONTROL DATA CORPORATION
CDC 9409 DOUBLE-SIDED, 48TPI, 320/360KB 245
Tandon
TM100-2 DOUBLE-SIDED, 48TPI, 320KB 230
TM101-4 DOUBLE-SIDED, 96TPI, 640KB 295

5 1/4" 1/2 HEIGHT INTERNAL MOUNTING FLEXIBLE DISK DRIVES (INCLUDES STRAP KITS TO MOUNT IN FULL HEIGHT FOOTPRINT) 6 MS. STEP RATE
Tandon TM50-2
DOUBLE-SIDED, 48TPI (2) DRIVES FOR 395
QUMETRAK 142
DOUBLE-SIDED, 48TPI (2) DRIVES FOR 425
TEAC FD 55-B
DOUBLE-SIDED, 48TPI (2) DRIVES FOR 575
TEAC FD 55-F
DOUBLE-SIDED, 96TPI (2) DRIVES FOR 750
IBM 4 DRIVE ADAPTOR CABLE Call

IBM PC DOS SOFTWARE UTILITIES FROM TALL TREE SYSTEMS
J FORMAT ENABLES USE OF 5 1/4", D/S, 96TPI & 8" FLEXIBLE DISK DRIVES PLUS OTHER FEATURES FOR IBM PC DOS 1.10 VERSION 1.78 50
J FORMAT-2SAME AS J FORMAT ABOVE FOR IBM PC DOS 2.0 35
WINDRIVE ENABLES USE OF WINCHESTER SUBSYSTEMS FOR IBM PC DOS 2.0 35
JETDRIVE ENABLES IMPLEMENTATION OF ELECTRONIC DISK FOR IBM PC DOS 2.0 35
J UTILITIES INCLUDES J FORMAT-2, WINDRIVE & JETDRIVE 95

GD CONTROL DATA CORPORATION DISKETTES
1242-00 5 1/4" SINGLE-SIDED, SINGLE/DOUBLE DENSITY, WRITE PROTECT NOTCH & HUB RING (Box of 10) Special 19.95
1244-00 5 1/4" DOUBLE-SIDED, SINGLE/DOUBLE DENSITY, WPN & HUB RING ... (Box of 10) Special 29.95
— 8" SINGLE OR DOUBLE-SIDED, SINGLE/DOUBLE DENSITY, WPN & HUB RING, VARIOUS FORMATS ... Call

apple DISK DRIVES
DATA DRIVES 5 1/4" FLEXIBLE DISK EXTERNAL SUBSYSTEM BY TAVA CORP. 275

MICROXPRESS

(714) 632-8512
305 S. State College Blvd.
Suite 135
Anaheim, CA 92806



Listing 1 continued:

```

70EF 2AF870 01820 ; LD HL, (TKBDR) ;SET NEW KEYBOARD VECTOR
70F2 221640 01830 LD (KBDADR),HL
70F5 C9 01840 RET
01850
01860 ;
70F6 01870 COMREG DEFS 2 ;COMMAND ADDRESS REG
70F8 01880 TKBDR DEFS 2 ;KEYBOARD VECTOR REG
01890 ;
70FA 42 01900 COMD DEFM 'BASIC'
70FF 0D 01910 DEFB 0DH
7100 0D 01920 DEFB 0DH ;RETURN FOR # OF FILES ?
7101 0D 01930 DEFB 0DH ;RETURN FOR MEMORY SIZE ?
7102 52 01940 DEFM 'RUN"DATE"' ;RUN SPECIFIED PROGRAM
710B 0D 01950 ECOMD DEFB 0DH ;END OF COMMAND SEQUENCE
7200 01960 ORG 7200H
01965 ;
7200 01970 BEGIN EQU $ ;BEGINNING ADDRESS OF PROGRAM
01980 ;
01990 ; ROUTINE TO ECHO KEYBOARD
02000 ;
02010 ; PROGRAM GOES TO KEYBOARD DRIVER THEN RETURNS TO ECHO
02020 ;
02030 ; ALL KEYS EXCEPT ENTER SPOKEN
02040 ; IF SAME LETTER IS IMMEDIATELY SENT TO DISPLAY,
02050 ; IT WILL NOT BE REPEATED
02060 ; SHIFT @ KEY TOGGLES TALKER ON/OFF
02070 ;
7200 CDE303 02100 ECHO CALL 03E3H ;CALL OLD KEYBOARD ROUTINE
7201 02110 KBDRET EQU $-2 ;KEYBOARD ROUTINE ADDRESS
02120 ;
7203 B7 02150 OR A ;TEST CHAR RETURNED FROM KEYBOARD
7204 CB 02160 RET Z ;RETURN IF 0 (NO CHARACTER)
02170 ;
7205 4F 02180 LD C,A ;SAVE CHARACTER
7206 21DF72 02190 S1 HL,TOGG ;ECHO ON/OFF REGISTER
7209 FE60 02200 CP 60H ;TEST FOR SHIFT @
720B 2B19 02210 JR Z,ONOFF ;TOGGLE TALKER ON/OFF IF SHIFT @
02220 ;
720D 34 02230 INC (HL) ;TEST TOGGLE REG FOR 0
720E 35 02240 DEC (HL) ;WHICH MEANS TALKER OFF
720F CB 02250 RET Z ;RETURN IF TALKER OFF
02260 ;
7210 23 02270 INC HL ;POINT HL @ LAST CHARACTER REG
7211 77 02280 LD (HL),A ;SAVE CHAR
02290 ;
7212 23 02300 INC HL ;POINT HL @ KEYBOARD REGISTER
7213 34 02310 INC (HL) ;SET KEYBOARD REGISTER
02320 ;
7214 23 02330 INC HL ;POINT HL @ SPACE FLAG REGISTER
7215 23 02340 INC HL ;POINT HL @ LETTER FLAG REGISTER
7216 CBF5 02350 SET 7,(HL) ;SET LETTER FLAG REGISTER
02360 ;
721B C5 02370 PUSH BC
7219 CDB372 02380 F11 CALL FIND ;SPEAK LETTER OR COMMAND
721C C1 02390 POP BC
721D FE0D 02400 CP ODH ;SEE IF A REG RETURNS WITH C/R
721F 2B03 02410 JR Z,TKRET ;JUMP IF IT DOES
02420 ;
7221 CDC672 02430 T2 CALL CR ;OTHERWISE SEND C/R
7224 79 02440 TKRET LD A,C ;RECOVER ORIGINAL CHARACTER
7225 C9 02450 RET
02460 ;
02470 ; ROUTINE TO TURN TALKER OFF OR ON IF SHIFT @ KEYS HIT
02480 ;
7226 AF 02490 ONOFF XOR A ;CLEAR A REG
7227 BE 02500 CP (HL) ;TEST TOGGLE REG FOR 0 (OFF)
7228 77 02510 LD (HL),A ;SET TOGGLE REG TO 0
7229 79 02520 LD A,C ;RECOVER ORIGINAL CHAR (60H)
722A C0 02530 RET NZ ;RETURN IF TOGGLE REG WAS NOT 0
722B 34 02540 INC (HL) ;OTHERWISE SET TOGGLE REG TO 1
722C C9 02550 RET
02570 ; ROUTINE TO READ TEXT THAT IS SENT TO THE DISPLAY
02580 ;
02590 ;CHARACTER IS SENT TO TALKER BEFORE IT GOES TO DISPLAY
02600 ; COMMANDS NOT SPOKEN BUT CARRIAGE RETURN (C/R) SENT
02610 ; AUTOMATIC C/R IF 2 CONSEQUITIVE SPACES
02620 ; WILL NOT REPEAT CHAR JUST ENTERED ON KEYBOARD
02630 ; CHAR 07 TURNS TALKER ON
02640 ; CHAR 06 TURNS TALKER OFF
02650 ; CHAR 05 SPEAKS BOTH LETTERS & PUNCTUATION
02660 ; CHAR 04 SPEAKS LETTERS ONLY
02670 ;
722D 3B29 02680 TCRT JR C,DISP ;IF READ FROM DISP SKIP TALKER
02690 ;
722F 21DF72 02700 S2 LD HL,TOGG ;TALKER ON/OFF REGISTER
7232 79 02710 LD A,C ;NEW CHARACTER
7233 FE07 02720 CP 07H ;TEST FOR TALKER ON SWITCH CHAR
7235 2003 02730 JR NZ,CON1 ;JUMP IF NOT
7237 3601 02740 LD (HL),1 ;SET TOGGLE REGISTER ON
7239 C9 02750 RET ;RETURN
02760 ;
723A 3016 02770 CON1 JR NC,CONT ;SKIP IF NOT SWITCH CHARACTER
02780 ;
723C FE06 02790 CP 06H ;TEST FOR TALKER OFF SWITCH CHAR
723E 2003 02800 JR NZ,CON2 ;JUMP IF NOT
7240 3600 02810 LD (HL),0 ;SET TOGGLE REGISTER OFF
7242 C9 02820 RET
    
```

Listing 1 continued on page 460

Hayes

Your Apple's telephone.



"Thanks for the prompt reply. Sure was a lot faster than waiting for the mail!"

"Gary: The pedigrees for next week's auction are as follows.."

"Attn. Prod., Sales, Purch.; Recommend 50% blue, 30% red screen for closest match!"

A complete plug-in communications system for Apple® computers. From Hayes, the established telecomputing leader: the simple but sophisticated Micromodem II™ plug-in board modem and its companion software, Smartcom I.™ Everything you need to expand the world of your Apple II, IIe, II Plus and Apple III. In one, convenient communications package.

With Micromodem II and Smartcom I, you can access data bases, bulletin boards, and the varied resources of information services. Plan your travel itinerary via computer, including flight numbers, hotel and rental car reservations. Retrieve and analyze daily stock and options prices. Work at home and send reports to your office. You can even do your gift shopping by computer!

Micromodem IIe. Think of it as your Apple's telephone. It allows your computer to communicate with any Bell-103 type modem over ordinary telephone lines, at 110 or 300 bits per second. Micromodem IIe installs easily in an expansion slot, and requires no outside power source. It connects directly to either a single or multiline modular phone jack, to perform both Touch-Tone® and pulse dialing.

Micromodem IIe dials, answers and disconnects calls automatically. And, unlike some modems, it operates in full or half duplex, for compatibility with most time-sharing systems.

A built-in speaker lets you monitor your



calls when dialing. That way, you'll know if a line is busy. With Smartcom I, Micromodem IIe automatically redials your last number.

Discover how Micromodem IIe can help maximize the capabilities of your Apple. While Smartcom I software will minimize your efforts.

Smartcom I companion software. For effortless communications. Whether you're a newcomer to personal computing or a seasoned professional, you'll appreciate the ease and speed with which you can perform any communications function. Thanks to Smartcom I!

Let Smartcom I guide you through a few easy-to-answer questions to tailor the program to your particular needs. Then you're ready to go!

Make a selection from the Smartcom I menu to manage your communications, files or printer. Program prompts guide you along the way. And menu selections let

you easily make a call, end a call, or answer a call. When you're on the receiving end, your Micromodem IIe answers automatically, even if you're not there!

Convenient! And so is the Smartcom I memory for phone numbers. Smartcom I stores three of your most frequently called telephone numbers and one prefix. Plus, it also remembers the last number dialed.

Smartcom I also provides a directory of the files stored on your disk.

And lets you create, list, name, send, receive, print or erase files right from its menu.

Smartcom I is as versatile as you need it to be. It accepts DOS 3.3, Pascal, CP/M™ 3.0 or CP/M Plus™ operating systems. And accommodates up to six disk drives and several printer interface cards.

Like all our products, Smartcom I and Micromodem IIe are backed by excellent documentation and full support. Including a two-year limited warranty on Micromodem IIe and a 90-day warranty on Smartcom I!

See your dealer today. Then plug into the exciting world of telecomputing.

Hayes Microcomputer Products, Inc., 5923 Peachtree Industrial Blvd., Norcross, Georgia 30092. 404/449-8791.



FCC approved In U.S.A.
©1983 Hayes Microcomputer Products, Inc.
Micromodem IIe and Smartcom I are trademarks of Hayes Microcomputer Products, Inc. Apple Computer is a registered trademark of Apple Computer, Inc. Touch-Tone is a registered trademark of American Telephone and Telegraph. CP/M is a trademark of Digital Research, Inc. CP/M Plus is a trademark of Advanced Logic Systems.

S-100 Boards from S. C. Digital



NEW 80186 CPU BOARD

features: **Model: 80186 CPU**
 • Intel 80186 Based • Executes 8086 codes plus 10 additional • built in DMA channels, timers, interrupt controller • Interface to Numeric Data Processor, 8087 • 8 or 16 bit data transfer, with 4 or 8 MHz clock • Provision to run 2 different CPU's on the bus, such as our M:280 CPU.

Z808 CPU BOARD

features: **Model Z80 CPU**
 • 2, 4 or 6 mhz clock. • 22 bit Address by Memory Mapping in 16K blocks. • 2 or 4Kbyte EPROM (not supplied) with Phantom generation. • Jump on Reset. • Provision to run two different CPU's on the same bus, such model 8186 CPU.

FLOPPY DISK CONTROLLER

features: **Model FDC1**
 • Single or Double density, sides, in any combination of up to four 8" or 5.25" drives. • Digital phase locked loop. • DMA data transfer with cross 64K boundaries, 248 address, DMA arbitration. • Monitor/boot EPROM accommodating two different processors. • CPM Bios programs. • Serial port to 19.2K baud.

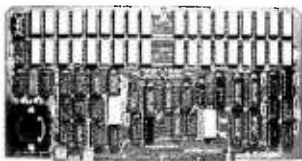

256K DYNAMIC RAM

features: **Model 256KZ**
 • 8/168 Data, 248 Address. • Parity bit per Byte • Transparent refresh • Unlimited DMA • 180nsec. Access time • Will run 8086, 8088, 68000 to 8mhz, Z80, Z8000 to 6mhz without wait states.

64K STATIC RAM

features: **Model 64KS**
 • 8/168 Data 248 Address • Disable in 2K increments • 180nsec Access Time (with 64KB) from address on, runs 8086, 68000 to 10mhz, Z80, Z8000 to 8mhz without wait states • Battery back up capable.

Board Sets: For Limited Time Only!
 • Z80B CPU, DMA Floppy Controller, CP/M Plus 256KB Ram \$1,350

All boards conform to IEEE896/S100 specifications, fully socketed, screened legends, masks. Gold contacts. Guaranteed One Full Year.

Model	Prices	with
80186 CPU	\$595	16 Bit CPU
Z80 CPU	\$325	Memory Mapping, 8 mhz
FDC 1	\$395	Monitor EPROM
758KZ	\$749	256KB. Parity
256KZ-128	\$849	428KB. Parity
64KS	\$425	64KB. CMOS
32KUSM	\$295	32KB. CMOS
3SPC	\$259	3 serial, 1 parallel, cassette
CP/M Plus	\$155	Purchased with FDC1
Z80 Monitor	\$55	2K in EPROM, source code, for 35 PC

All Boards come assembled and tested.
 Prices subject to change without notice.

Delivery is within 3 to 5 working days. MC, Visa or COD orders accepted. (Add \$6 for COD orders) Illinois residents add 5 1/2% sales tax.

*CP/M is a registered trademark of Digital Research, Inc.
 O.E.M. & DEALER PRICE AVAILABLE

S.C. DIGITAL, INC.
 1240 N. Highland Ave., Suite #4
 P. O. Box 906, Aurora, Illinois 60507
 Phone: (312) 897-7749

Listing 1 continued:

7243 FE05	02830 ;			
7245 2004	02840 CON2	CP	OSH	; LETTER & PUNCTUATION SWITCH CHAR
7247 32E372	02850	JR	NZ,CON3	
724A C9	02860 CONS	LD	(LTRFLG),A	; SET LETTER FLAG REGISTER
	02870	RET		
	02880 ;			
724B FE04	02890 CON3	CP	04H	; LETTERS ONLY SWITCH CHAR
724D 2009	02900	JR	NZ,DISP	; GO TO DISPLAY IF NOT
724F AF	02910	XOR	A	; CLEAR A REGISTER
7250 18F5	02920	JR	CONS	; SET LETTER FLAG REGISTER ON
	02940 ;			ROUTINE TO CHECK FOR COMMANDS SENT TO DISPLAY
	02950 ;			ALSO MULTIPLE SPACE COMMANDS
	02960 ;			
7252 C5	02970 CONT	PUSH	BC	
7253 CD5B72	02980	CALL	DISTLK	; SPEAK CHARACTER SENT TO DISPLAY
7256 C1	02990	POP	BC	
7257 AF	03000	XOR	A	; CLEAR CARRY
7258 C35B04	03010 DISP	JP	45BH	; GO TO DISPLAY DRIVER
7259	03020 CRTRET	EQU	%-2	; DISPLAY DRIVER ADDRESS
	03030 ;			
	03040 ;			
725B 34	03050 DISTLK	INC	(HL)	; TEST TOGGLE REG FOR 0
725C 35	03060	DEC	(HL)	
725D CB	03070	RET	Z	; RETURN IF TALKER OFF
	03080 ;			
725E 23	03090	INC	HL	; POINT HL @ LAST CHARACTER REG
725F 46	03100	LD	B,(HL)	; LAST CHARACTER
7260 3620	03110	LD	(HL),20H	; STORE SPACE IN LAST CHAR REG
7262 79	03120	LD	A,C	; GET NEW CHARACTER
7263 FE0C	03130	CP	0COH	; CHECK FOR SPACE COMPRESSION CODE
7265 305B	03140	JR	NC,SPACE	; SEND SPACE IF TRUE
	03150 ;			
7267 71	03160	LD	(HL),C	; LOAD REG WITH NEW CHARACTER
7268 23	03170	INC	HL	; POINT HL @ KEYBOARD FLAG REGISTER
7269 35	03180	DEC	(HL)	; TEST FOR KEYBOARD FLAG
726A 3600	03190	LD	(HL),0	; RESET KEYBOARD FLAG REGISTER
726C 2002	03200	JR	NZ,LNFK	; JUMP IF LAST INPUT NOT FROM KBD
	03210 ;			
726E BB	03220	CP	B	; COMPARE LAST & NEW CHARACTERS
726F CB	03230	RET	Z	; RETURN IF SAME
	03240 ;			
7270 23	03250 LNFK	INC	HL	; POINT HL @ SPACE FLAG REG
7271 FE20	03260	CP	20H	; SEE IF IT IS A SPACE
7273 3B51	03270	JR	C,CR	; SEND C/R IF IT IS A COMMAND
	03280 ;			
7275 2009	03290	JR	NZ,NSPC	; SPEAK CHARACTER IF NOT SPACE
	03300 ;			
7277 BB	03310	CP	B	; IF IT IS A SPACE SEE IF LAST
7278 204E	03320	JR	NZ,SEND	; CHAR WAS ALSO & SEND IF NOT
	03330 ;			
727A 34	03340	INC	(HL)	; TEST SPACE FLAG REG
727B 35	03350	DEC	(HL)	
727C CB	03360	RET	Z	; RETURN IF SPACE FLAG SET
	03370 ;			
727D 34	03380	INC	(HL)	; SET SPACE FLAG
727E 1846	03390	JR	CR	; SEND C/R
	03400 ;			
7280 3600	03410 NSPC	LD	(HL),0	; RESET SPACE FLAG REGISTER
7282 23	03420	INC	HL	; POINT HL @ LETTER FLAG REGISTER
	03440 ;			ROUTINE TO SPEAK CHARACTERS
	03450 ;			
	03460 ;			COMMANDS SPOKEN IF FROM KEYBOARD
	03470 ;			PUNCTUATION SPOKEN ONLY IF LETTER FLAG NOT 0
	03480 ;			CHARACTERS ABOVE 7BH ARE IGNORED
	03490 ;			
7283 FE7B	03500 FIND	CP	7BH	
7285 D0	03510	RET	NC	; RETURN (IGNORE) IF CHAR >7BH
	03520 ;			
	03530 ;			SEE IF CHAR =5BH (UP ARROW) THIS IS THE ONLY CHARACTER
	03540 ;			RECOGNIZED BETWEEN 5AH & 60H
	03550 ;			
7286 FE5B	03560	CP	5BH	
7288 2B0C	03570	JR	Z,WORD	; A=5BH
	03580 ;			
	03590 ;			SEE IF CHARACTER IS A LETTER (UPPER OR LOWER CASE)
	03600 ;			
728A FE41	03610	CP	'A'	
728C 303A	03620	JR	NC,SEND	; 41H<A<7AH
	03630 ;			
	03640 ;			SEE IF CHARACTER IS A PUNCTUATION MARK ; <=>?@
	03650 ;			
728E FE3A	03660	CP	' ; '	
7290 3004	03670	JR	NC,WORD	; 39H<A<41H
	03680 ;			
	03690 ;			SEE IF CHARACTER IS A NUMBER
	03700 ;			
7292 FE30	03710	CP	' 0 '	
7294 3032	03720	JR	NC,SEND	; 2FH<A<3AH
	03730 ;			
	03740 ;			OTHERWISE CHAR MUST BE A COMMAND OR PUNCTUATION MARK
	03750 ;			
	03760 ;			
	03770 ;			ROUTINE TO FIND THE PROPER WORD TO SPEAK
	03780 ;			FOR COMMANDS & PUNCTUATION
	03790 ;			
7296 46	03800 WORD	LD	B,(HL)	; SAVE LETTER FLAG FOR USE LATER
7297 CBBE	03810	RES	7,(HL)	; CLEAR KBD FLAG IN LETTER FLAG REG
	03820 ;			
7299 23	03830 TERM	INC	HL	; POINT HL TO BEGINNING OF TABLE

Listing 1 continued on page 462

THE ONE AND ONLY

CRAMBO

You've got a problem. Go to your favorite computer store. Ask to see their Combo Cards. Then ask about their RAM Cards. See the problem? Just too many to pick from. Now, ask to see the CRAMBO™. No problem. There's only one. Ours. Except you don't know what a CRAMBO is. You've probably guessed it's a Combo Card piggy backed to a RAM Card. So it only takes up one slot in your IBM/PC. That's right. But here are the details.

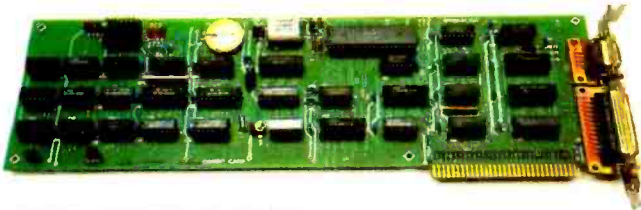

THE COMBO II CARD:

For **\$189** you'll get a Clock Calendar, Async Communications, Parallel Printer and a Game Adapter.

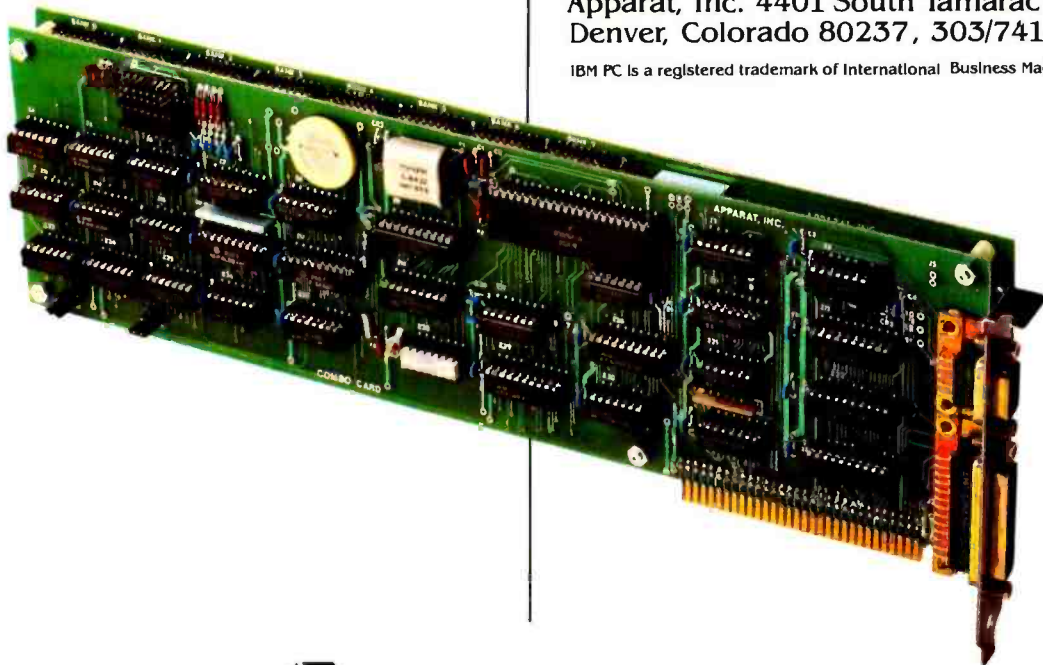

THE 512K RAM CARD:

It too, is only **\$189** with 64K of RAM installed. And when you need more RAM, 64K increments are available for \$64 each. And, SDRIVE, the electronic disk emulator, is available at no cost with the RAM Card.

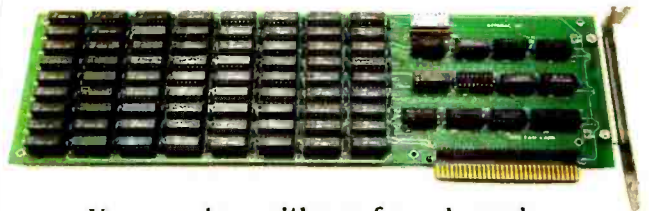

You can buy either of our boards separately for use in the XT or PC expansion chassis. But only our boards can be piggy backed to give you the one and only CRAMBO. And for only **\$359**.

Go check out the CRAMBO at the same store carrying all those Combo Cards and RAM Cards. If they don't have the CRAMBO have them call us. **800/525-7674**. Or write: Apparat, Inc. 4401 South Tamarac Parkway, Denver, Colorado 80237, 303/741-1778.

IBM PC is a registered trademark of International Business Machine Corp.

 **Apparat, Inc.**

Circle 38 on inquiry card.

www.americanradiohistory.com

Applications Software Developers

Write more powerful applications with Idris, Whitesmiths' more powerful operating system.

To produce the high quality applications today's business environments require, you need a powerful, sophisticated operating system. Idris, the fastest, most complete UNIX-like system for micros, meets your needs. Idris offers:

- multi-user, multi-tasking capabilities
- networking, even between dissimilar computers
- application portability from Idris to UNIX and UNIX to Idris
- ROM-ability

SEND FOR OUR FREE BOOKLET "THE PROFIT-BUILDERS' CHECKLIST"

Our new booklet gives you a quick and easy way to check the benefits of Whitesmiths' full line of products. See for yourself how you can produce more powerful applications, cut your costs, widen your markets, and build your bottom line.

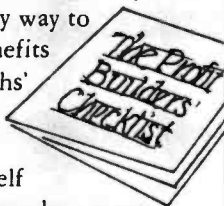

Idris is a trademark of Whitesmiths, Ltd.; UNIX is a trademark of Bell Laboratories.



Whitesmiths, Ltd.
97 Lowell Road
Concord, Mass. 01742
(617) 369-8499

NAME _____
TITLE _____
COMPANY _____
ADDRESS _____
CITY _____
STATE _____ ZIP _____
TELEPHONE _____

Listing 1 continued:

729A CB7E	03840	BIT	7, (HL)	; FIND TERMINATING CHAR
729C 23	03850	INC	HL	
729D 28FB	03860	JR	Z, *-3	
	03870 ;			
729F 7E	03880	LD	A, (HL)	; GET CHARACTER FROM TABLE
72A0 E67F	03890	AND	7FH	; REMOVE FLAG BIT
72A2 C8	03900	RET	Z	; RETURN IF END OF TABLE
	03910 ;			
72A3 B9	03920	CP	C	; COMPARE TO NEW CHARACTER
72A4 20F3	03930	JR	NZ, TERM	; CONTINUE SEARCH IF NOT SAME
72A6 78	03940	LD	A, B	; TEST LETTER FLAG TO SEE IF ALL
72A7 B7	03950	OR	A	; PUNCT TO BE SPOKEN
72A8 2004	03960	JR	NZ, *+6	; SEND REGARDLESS IF SET
72AA CB7E	03970	BIT	7, (HL)	; CHECK CHAR FLAG IN TABLE
72AC 2814	03980	JR	Z, SPACE	; SEND SPACE IF CHAR NOT ALLOWED
	04000 ;			
	04010 ;			
72AE CDC272	04020	CALL	SPACE	; SEND SPACE TO SEPARATE WORD
72B1 23	04030	INC	HL	
72B2 7E	04040	LD	A, (HL)	
72B3 CDCB72	04050	T1 CALL	SEND	; SEND WORD
72B6 CB7E	04060	BIT	7, (HL)	; CHECK FOR TERMINATOR
72B8 28F7	04070	JR	Z, SPKWD	; CONTINUE IF NOT TERMINATOR
	04080 ;			
72BA 7E	04090	LD	A, (HL)	
72BB FEA0	04100	CP	0A0H	; IF TERMINATOR = A0H CONTINUE
72BD 2007	04110	JR	NZ, CR	; OTHERWISE SEND C/R
72BF 23	04120	INC	HL	
72C0 18EF	04130	JR	SPKWD	
	04140 ;			
	04150 ;			
	04160 ;			
	04170 ;			
	04180	SPACE LD	A, 20H	; SEND SPACE TO VOTRAX
72C2 3E20	04190	JR	SEND	
72C4 1802	04200 ;			
72C6 3E0D	04210	CR LD	A, 0DH	; SEND C/R TO VOTRAX
	04220 ;			
72C8 F5	04230	SEND	PUSH	AF ; SAVE CHARACTER
	04240 ;			
72C9 DBEA	04250	SEND1	IN	A, (0EAH) ; CHECK RS-232 STATUS
72CB CB77	04260	BIT	6, A	
72CD 28FA	04270	JR	Z, SEND1	; LOOP IF RS-232 NOT READY
	04280 ;			
72CF AF	04290	XOR	A	; DELAY FOR ONE FRAME GIVE VOTRAX
72D0 3D	04300	DELAY	DEC	A ; TIME TO RESET CLEAR TO SEND LINE
72D1 20FD	04310	JR	NZ, DELAY	
	04320 ;			
72D3 DBE8	04330	SEND2	IN	A, (0EBH) ; SEE IF VOTRAX READY TO RECEIVE
72D5 CB7F	04340	BIT	7, A	; CLEAR TO SEND (CTS) TRUE
72D7 20FA	04350	JR	NZ, SEND2	; LOOP IF NOT READY
	04360 ;			
72D9 F1	04370	PDP	AF	; RESTORE CHARACTER
72DA E67F	04380	AND	7FH	; REMOVE FLAG BIT
72DC D3EB	04390	OUT	(0EBH), A	; SEND CHARACTER TO RS-232
72DE C9	04400	RET		
	04420 ;			
	04430 ;			
	04440	T0GG	DEFB	1 ; TALKER ON/OFF FLAG REGISTER
72DF 01	04450	DEFB	0	; LAST CHARACTER REGISTER
72E0 00	04460	DEFB	0	; KEYBOARD REGISTER
72E1 00	04470	DEFB	0	; SPACE FLAG REGISTER
72E2 00	04480	LTRFLG	DEFB	1 ; LETTERS & NUMBERS ONLY FLAG REG
72E3 01	04490			
	04500 ;			
	04510 ;			
	04520	DEFB	80H	; TABLE MUST START W/ 80H
72E4 80	04530 ;			
72E5 3B	04540	DEFB	' ; '	
72E6 53	04550	DEFM	' SEMI '	
72EA A0	04560	DEFB	0A0H	
	04570 ;			
72EB 3A	04580	DEFB	' ; '	
72EC 43	04590	DEFM	' COLO '	
72F0 CE	04600	DEFB	' N' +80H	
	04610 ;			
72F1 3C	04620	DEFB	' < '	
72F2 4C	04630	DEFM	' LES '	
72F5 D3	04640	DEFB	' S' +80H	
	04650 ;			
72F6 BD	04660	DEFB	' = ' +80H	; ALWAYS SPOKEN
72F7 45	04670	DEFM	' EEQUAL '	
72FD D3	04680	DEFB	' S' +80H	
	04690 ;			
72FE 3E	04700	DEFB	' > '	
72FF 47	04710	DEFM	' GRATE '	
7304 D2	04720	DEFB	' R' +80H	
	04730 ;			
7305 3F	04740	DEFB	' ? '	
7306 51	04750	DEFM	' QUESTIO '	
730D CE	04760	DEFB	' N' +80H	
	04770 ;			
730E C0	04780	DEFB	' @ ' +80H	; ALWAYS SPOKEN
730F 41	04790	DEFM	' A '	
7310 D4	04800	DEFB	' T' +80H	
	04810 ;			
7311 21	04820	DEFB	' ! '	
7312 45	04830	DEFM	' EXCLAMATIO '	
731C CE	04840	DEFB	' N' +80H	

The CONCEPT AVT

Because VT100 users deserve more than just VT100 compatibility.



THE CONCEPT DISPLAY TERMINAL

VT100 compatibility is one thing, but eight pages of memory, programmable function keys, windowing, multiple computer capabilities, ANSI standard conformance...and VT100 compatibility is something else. Only from Human Designed Systems.

A good news/great news story from Human Designed Systems.

First the good news. The *concept* AVT display terminal gives you everything you need in an 80/132-column ANSI/VT100-compatible display terminal. And at a very competitive price.

Now the great news. The *concept* AVT display terminal provides an exciting, new set of capabilities that lets you do much more. Without changing the price.

It starts with ANSI standard conformance, DEC software compatibility, and 80/132-column capability, and extends that even further by offering eight pages of display memory to relieve the interactive user of the need to generate unnecessary hardcopy printouts and to provide the application developer with a powerful tool for applications requiring multiple formats and storage of large volumes of text; by enabling users to permanently configure a terminal for their needs or applications; by providing functionality

\$1295*

designed to improve the effectiveness of slow-speed applications; by enabling users to create true windows within display memory; by providing programmable function keys which transmit data and/or execute terminal commands; by providing up to three additional communications ports for connection to other

peripherals and computers; by providing flexible user networking functionality for use in a wide range of different applications, including multiple computer connections; and by doing much more.

VT100 compatibility and ANSI standard conformance. Add it to the *concept* display terminal's 132-column performance, in ASCII or APL/ASCII models, with multiple computer capabilities, windowing, programmable function keys, multiple pages of memory, and much more, and you can see why Human Designed Systems has given terminals a new meaning...and that means true economy.

human designed systems, inc.

3440 Market Street, Philadelphia, PA 19104
215-382-5000

*Quantity one. DEC and VT are trademarks of Digital Equipment Corporation.

Human Designed Systems. We're redefining terminal performance.

Atlanta — (404) 391-9763; Boston — (617) 329-3510; Chicago — (312) 825-2960; Dallas — (214) 437-1888; Delaware — Infocon: (302) 239-2942; Denver — (303) 469-1953; Hawaii — Gray Associates: (808) 261-3751; Los Angeles — (213) 410-9454; Northern New Jersey — Infocon: (201) 624-1372; New York City Area — Infocon: (212) 689-8833; New York State — Naco Electronics: Rochester: (716) 223-4490; Syracuse: (315) 699-2651; San Francisco — (415) 692-4184; Washington, DC — International Systems Marketing: (301) 279-5775; Argentina — Itron SA: (01) 744-9369; Australia — Computer Clarity PTY Ltd.: (02) 241 3885; I. O. Peripherals Pty. Limited: (02) 427 3555; Belgium — BELCOMP: 091/25 22 88; Canada — CALL Systems: Toronto: (416) 362-1063; Denmark — ADCOM Data Aps: 1-19 44 66; Finland — Modulsystem OY: 0-6926511; France — Walton: (1) 226.06.90; Singapore — DTS Singapore: (65) 33-88-566; Switzerland — Milek ag: 02/461 22 52; United Kingdom — Shandell Systems Ltd.: 02407-2027; West Germany — COMKO Computersystemges, mbH: 0221-48 30 51. INTERNATIONAL DISTRIBUTORSHIP INQUIRIES INVITED.

Circle 213 on inquiry card.

www.americanradiohistory.com

KEY TRONIC POLISHES THE APPLE II* KEYBOARD



Eleven Function Keys
Streamline Multiple
Key Operations

Full Shifting Capability

Keys in Familiar
Typewriter Locations

Numeric Pad

10 Foot Cable
For Portability

Enhance your APPLE II* Computer System with a Key Tronic keyboard peripheral. This detached, low-profile keyboard is plug-compatible with the existing keyboard socket of the Apple II. It also features reliable microprocessor electronics, solid-state capacitance switches, and positive tactile feedback.

Special keyboard available for the handicapped — factory direct.

*Apple II is a registered trademark of Apple Computer, Inc.

Suggested Retail Price: \$298.00

To order Model KB-200 call Toll Free 1-800-262-6006 for the retailer closest to you. (8am-4pm Pacific Time) Warranty information may be obtained, free of charge, by writing to the address below.

 **key tronic**

THE RESPONSIVE KEYBOARD COMPANY

DEPT. E1 • P. O. BOX 14687 • SPOKANE, WASHINGTON 99214 USA

RETAILERS: For the Distributor in your area, call Toll Free 1-800-262-6006 Dept. D (8am-4pm Pacific Time)

Circle 261 on Inquiry card.

```

73B3 00      05B50      NOP          ;TABLE MUST END W/ 00
              05B60 ;
73B4      05B70 LAST EQU      $          ;END OF ROUTINE
              05B80 ;
7010      05B90      END      START
00000 TOTAL ERRORS
    
```

SYMBOL TABLE

```

BASIC 70A6 01390 01360
BEGIN 7200 01970 00590 00760 01310 01580
CH1 70ED 01800 01770
CHAIN 70DC 01700 01630
COMD 70FA 01900 01660
COMREG 70F6 01870 01670 01700 01730
CON1 723A 02770 02730
CON2 7243 02840 02800
CON3 724B 02890 02850
CONS 7247 02860 00940 02920
CONT 7252 02970 00900 02770
CR 72C6 04210 01090 02430 03270 03390 04110
CRTADR 401E 00240 00290 01220 01490
CRTRET 7259 03020 00300
DELAY 72D0 04300 04310
DISP 725B 03010 02680 02900
DISTLK 725B 03050 00880 02980
ECHO 7200 02100 01240 01510
ECCMD 710B 01950 01740
F11 7219 02380 00860
F1ND 72B3 03500 00840 02380
HIMEM1 4049 00210 00530 00670
HIMEM3 4411 00220 00570 00650
KBDADR 4016 00230 00320 01260 01640 01840
KBDRET 7201 02110 00330
LAST 73B4 05B70 00590
LNFK 7270 03250 03200
LTRFLG 72E3 04480 00920 02860
NSPC 72B0 03410 03290
ONOFF 7226 02490 02210
S1 7206 02190 00980
S2 722F 02700 00990
SEND 72CB 04230 00460 00480 01050 03320 03620 03720 04050
      04190
SEND1 72C9 04250 04270
SEND2 72D3 04330 04350
SET1 703D 00590 00560
SET2 704C 00670 00640
SET3 704F 00690 00660
SPACE 72C2 04180 01130 03140 03980 04020
SPKWD 72B1 04030 01150 04070 04130
START 7010 00290 05B90
T1 72B3 04050 01070
T2 7221 02430 01110
TCRT 722D 02680 01200 01470
TERM 7299 03830 03930
TKBDR 70FB 01880 01530 01830
TKRET 7224 02440 02410
TOGG 72DF 04440 00960 02190 02700
WORD 7296 03800 03570 03670
    
```

Text continued from page 454:

the Talker program can execute. Knowing how and when to do this is difficult for a blind operator because there are no audio prompts. A patch to eliminate this problem was written by John Ratzlaff and appeared in the September 1982 issue of *80 Micro* (page 34). It is: patch*0:0 (Add=4EA9, Find=CA, Chg=C3).

Don't use the DO command and a chain file with TRSDOS because, when the command file is complete, the keyboard vectors are rewritten, bypassing Talker. Use the chain shown in listing 1 or use NEWDOS.

In a cassette system, the memory size must be set using the SYSTEM command before the program can be loaded and further programs run manually.

Regardless of which system you use, the Talker program consists of two major parts: the intercept routines and a relocation/initialization routine. When loaded and run, the initializing routine retrieves the keyboard and video-driver vectors, sets the RS-232C parameters, turns off the retransmission mode of the Type-N-Talk, relocates the intercept routines to the end of memory, determines if the host computer is a Model I or III and sets the high-memory pointer accordingly, inserts new addresses into the keyboard- and video-vector locations, and exits to DOS. The initialization routine is then discarded,

a message to our subscribers

From time to time we make the BYTE subscriber list available to other companies who wish to send our subscribers material about their products. We take great care to screen these companies, choosing only those who are reputable, and whose products, services, or information we feel would be of interest to you. Direct mail is an efficient medium for presenting the latest personal computer goods and services to our subscribers.

Many BYTE subscribers appreciate this controlled use of our mailing list, and look forward to finding information of interest to them in the mail. Used are our subscribers' names and addresses only (no other information we may have is ever given).

While we believe the distribution of this information is of benefit to our subscribers, we firmly respect the wishes of any subscriber who does not want to receive such promotional literature. Should you wish to restrict the use of your name, simply send your request to the following address.

BYTE Publications Inc
 Attn: Circulation Department
 70 Main St
 Peterborough NH
 03458



Plug 3,000 new applications into your Apple.®

THE CP/M Card™ plugs CP/M Plus™ into your Apple. The CP/M Card gives you the option of running your Apple II with the speed and capability of a professional Z-80 system with CP/M*-compatible software. You plug in the CP/M Card. Then choose CP/M or your standard Apple software at your option.

Plug into a big, new world of software.

The CP/M Card gives you instant access to the world's largest selection of microcomputer software—more than 3,000 CP/M-compatible applications, languages, and programming utilities. So, you, too can use professional business programs such as WordStar,* SuperCalc,™ Condor,™ and other high-performance software from Day One. Yet, you still have access to your present library of Apple software.

Plug into incredible performance.

Together, the ultra-fast CP/M Card and CP/M Plus run applications up to

300% faster than your Apple system! The CP/M Card is the only Apple II performance package that offers the speed and efficiency of CP/M Plus.

A plug about quality.

The CP/M Card was designed and built by Digital Research, the creators of CP/M, and Advanced Logic Systems, the most respected manufacturer of Apple performance products. So you know the CP/M Card is the most perfectly integrated Apple performance package you can buy.

Why just keep plugging along? The CP/M Card provides everything you need—including 64K of on-board memory, CP/M Plus, CBASIC,* GSX™-80 and full documentation—for just \$399.

Now available through the CP/M library. See your local microcomputer dealer today. Or contact Advanced Logic Systems, 1195 East Arques Ave., Sunnyvale, CA 94086 (800) 538-8177. (In California (408) 730-0306.)

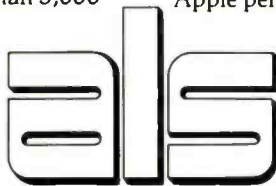

Advanced Logic Systems
The CP/M Card for your Apple II.

CP/M, CP/M Plus, the CP/M Card and CBASIC are either trademarks or registered trademarks of Digital Research Inc. Z-80 is a registered trademark of Zilog, Inc. WordStar is a registered trademark of MicroPro International Corporation. SuperCalc is a trademark of Sorcim Corporation. Condor is a trademark of Condor Computer Corporation. GSX-80 is a trademark of Graphics Software System. Apple is a registered trademark of Apple Computer, Inc. ©1982 Digital Research Inc.

Circle 18 on inquiry card.

www.americanradiohistory.com

and the memory space that it occupies can be reused.

The Keyboard Intercept

If the keyboard driver is called, the character returned from the normal keyboard routine is intercepted before it is sent back to the host program. If the character is a letter or number, it is transmitted to the Type-'N-Talk followed by a carriage return so that it is spoken immediately and no distinction is made between uppercase and lowercase letters (if available). If it is a punctuation mark or control character, it must be translated into a word or the Votrax unit will ignore it. This word is then sent and immediately spoken. Flags are set so that if the same character is immediately sent to the video-display driver, it is not repeated. The Talker program can be toggled off and on by pressing the Shift and @ keys simultaneously. This key combination represents the only command that can be sent to the Talker program directly from the keyboard.

The Video Intercept

If the video-display driver is called, the character is intercepted before it is sent to the display, and unless it is one of the special program control characters (numbers 04 through 07), it will be spoken and then sent on to the display. If the video driver is being used to read a character already on the display, the intercept program passes the request to the driver.

The video-intercept routine sends any number or letter (uppercase or lowercase) directly to the Type-'N-Talk. Control codes for the display (such as BACK SPACE and TAB) are not transmitted, but a carriage return is sent in their place, causing the previously transmitted text to be spoken. The carriage return and the space characters are transmitted directly. If two or more consecutive space characters are encountered, the first space is sent, a carriage return is sent in place of the second space character, and subsequent consecutive spaces are ignored.

Punctuation marks are translated

into words and sent to the Type-'N-Talk preceded by a space and followed by a carriage return, provided that the intercept routine has not been instructed to ignore them. The marks that are ignored and their pronunciation can be easily changed by modifying the lookup table in the program. For example, you may want to substitute PERIOD for POINT or DASH for MINUS.

All graphics codes are ignored. Space-compression codes result in a single space being sent to the Votrax unit. The special character codes of the Model III (numbers 192 through 255) are considered space-compression codes.

Four special codes can be used to control the intercept program. The BASIC statement PRINT CHR\$(4) will cause punctuation marks to be ignored; PRINT CHR\$(5) causes them to be spoken. This command has no effect on punctuation characters originating from the keyboard. PRINT CHR\$(6) causes the program to stop talking, and PRINT CHR\$(7)

BYTE Back issues for sale

	1976	1977	1978	1979	1980	1981	1982	1983
Jan.				\$2.75	\$3.25	\$3.25		\$3.70
Feb.			\$2.75	\$2.75	\$3.25	\$3.25	\$3.70	\$3.70
March			\$2.75	\$2.75	\$3.25	\$3.25	\$3.70	\$3.70
April			\$2.75	\$2.75	\$3.25	\$3.25	\$3.70	\$3.70
May		\$2.00	\$2.75	\$2.75	\$3.25	\$3.25	\$3.70	\$3.70
June		\$2.00	\$2.75	\$2.75	\$3.25	\$3.25	\$3.70	\$3.70

	1976	1977	1978	1979	1980	1981	1982	1983
July	\$2.00	\$2.00	\$2.75	\$2.75	\$3.25	\$3.25	\$3.70	\$4.25
Aug.		\$2.00	\$2.75	\$2.75		\$3.25	\$3.70	\$4.25
Sept.		\$2.75	\$2.75	\$2.75	\$3.25		\$3.70	\$4.25
Oct.			\$2.75	\$2.75	\$3.25	\$3.25		
Nov.				\$3.25		\$3.25	\$3.70	
Dec.		\$2.75	\$2.75	\$3.25	\$3.25	\$3.25	\$3.70	

Circle and send requests with payment to:
BYTE Back Issues
P.O. Box 328
Hancock, NH 03449

Please allow 4 weeks for domestic delivery and 8 weeks for foreign delivery.

name _____
 address _____
 city _____
 state _____ zip _____

The above prices include postage in the US. Please add \$.50 per copy for Canada and Mexico; and \$2.00 per copy to foreign countries.

Check enclosed

Payments from foreign countries must be made in US funds payable at a US bank.

VISA Master Card
 Card # _____ Exp. _____

Signature _____

The TTX-1014 Desktop Daisywheel.

Professional Printing. Personal Price.

Just \$649 buys
a letter-quality,
daisywheel printer.

You don't need a big-business budget to make your microcomputer's hard copy look like a million dollars. The TTX-1014 Desktop Daisywheel delivers true letter-quality, professional printing for just \$649.

\$649. Complete. The TTX-1014 comes complete with features that most printers offer only as expensive, extra-cost options. Like a pinfeed-forms guide. Plus built-in RS232C serial and Centronics-type parallel interfaces—both standard.

Performance. Not Problems. The compact TTX-1014 is built to handle all your letter-quality printing needs. Pin-feed forms? No problem. The TTX-1014 lets you use forms from 2 1/2 to 14 1/2 inches wide. Want a different typeface? No problem here, either. The 100-character ASCII printwheel can be changed in seconds...
and extra

daisywheels are available in computer stores and major retail outlets everywhere. And you can quickly select pitch (10, 12, or 15 characters/inch) and linespacing (3, 4, or 6 lines/inch) by program control or built-in switches. All that plus logic-seeking, bidirectional printing at up to 14 cps. And all for \$649.

Built Business Tough. In business, dependability counts. And the TTX-1014 is built to stand up to the rigors of business applications. At a typical 25% duty cycle, business users can look to a full 3000 hours of printing before servicing is required. And in home use and other light applications, the TTX-1014 can deliver many years of trouble-free operation.

Professional printing. Personal price. The TTX 1014-Desktop Daisywheel. Professional performance for just \$649. Try one at your dealer's today.

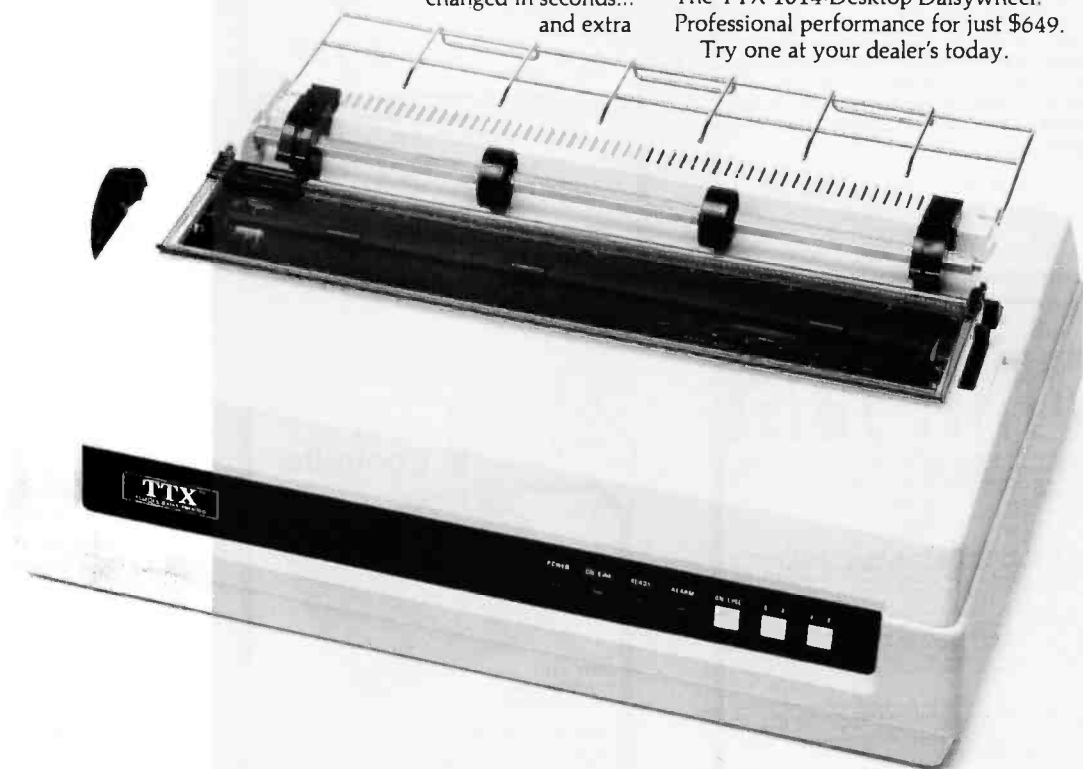

TTX™

Teletex Communication Corporation
3420 East Third Avenue
Foster City, California 94404
415/341-1300 TX:349420

\$649 is manufacturer's suggested retail price.

Circle 465 on inquiry card.

BYTE October 1983 469

ARBA Retail Systems Presents

THE MISSING LINK

THE HARDWARE

- RS 232 fully featured cash register —not just a cash drawer

THE SOFTWARE

- 99 depts.—65,000 item inventory
- Detailed inventory analysis and reports
- Prints price tags
- 12 digit alpha numeric part number
- Sales by employee
- Runs under CP/M or MP/M

THE SYSTEM . . .

now available from

ARBA Retail Systems
890 E. Roosevelt Road
Lombard, Illinois 60148
(312) 620-8566

Circle 44 on inquiry card.

RTL

Relocatable Threaded Language \$150

RTL is a new language which retains the speed and extensibility of Forth but adds many additional advantages as a result of its more structured dictionary. Names, code, and variables are all stored in separate areas for easy generation of headerless, romable code. All code is relocatable. RTL supports local variables, multitasking, redirected I/O, and even allows definitions to be changed retroactively. All source code is included. Versions are currently available or under development for 68000, 6809, 8080, 280, 8086, 8088, and 6502.

RTL Programming Aids
10844 Deerwood SE
Lowell, MI 49331
(616) 897-5672

Circle 405 on inquiry card.

uniforth

One of the finest implementations of the FORTH language. Field tested and reliable, UNIFORTH is available for the IBM PC as well as most systems with 8" disks and the following processors:

8080	PDP-11
Z80	68000
8086/8	16032

As a task, UNIFORTH is compatible with and supports all features and file types of the CP/M, CDOS, MS-DOS and DEC operating systems. As an operating system, UNIFORTH will function "stand-alone" on most commercial microcomputers.

The FORTH-79 Standard language has been extended with over 800 new words that provide full-screen and line-oriented editors, array and string handling, enhanced disk and terminal I/O, and an excellent assembler. Detailed reference manuals supply complete documentation for programming and system operation, in an easy-to-understand, conversational style using numerous examples.

Optional features include an excellent floating-point package with all transcendental functions (logs, tangents, etc.), the MetaFORTH cross-compiler, printer plotting and CP/M file transfer utilities, astronomical and amateur radio applications, word processing, etc.

Compare these features with any other FORTH on the market:

- Speed and efficiency
- Variety of options
- Ease of use
- Documentation quality

You'll find UNIFORTH is superior.

Prices start at \$35. Call or write for our free brochure.

Unified Software Systems

P.O. Box 2644, New Carrollton, MD 20784, (301) 552-1295

Circle 489 on inquiry card.

HEATH H-19/89 OWNERS

EXPAND YOUR SYSTEM WITH THIS SINGLE P.C. BOARD

- Color Graphics w/32 Sprites
16K Ram
- 6 Tone Music Stereo
Dual Noise Gen.
With 4 I/O Ports

\$299.00

gap electronics
Box 86491
San Diego, CA 92086
(619) 267-7547

Visa & MasterCard Accepted

Circle 398 on inquiry card.

COMPUTER SUPPLIES FOR ALL MAKES & MODELS

DISKETTES

5 1/4 S/S S/D
MIN. ORDER 50 **\$180**

RIBBONS

DIABLO HYTYPE II
MULTI STRIKE DR NYLON **\$388**

EPSON
MX70/MX80 **\$464**

EPSON
MX100
MIN. ORDER 6 **\$784**

LABELS • CONTINUOUS FORMS

CALL TOLL FREE 1-800-248-2418

IN N.Y. STATE (212) 967-1700

TERMS—VISA, MC OR COD
DEALER INQUIRIES INVITED

WORLDWIDE COMPUTER SUPPLIES
159 MAIN ST., S.J., N.Y. 10307

Circle 513 on inquiry card.

Z8^{*} SBC 8671 Basic Controller

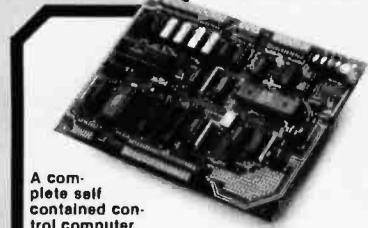

A complete self contained control computer.

Features: Z8000 microprocessor with 2K basic interpreter. Sockets for 48K of on board user memory. 48 parallel I/O lines, RS 232 & 20MA current loop serial communications, and more . . .

Custom & Oem versions also available **NOW ONLY \$285.00 each**

*Z8 is a Trademark of Zilog Corp.



Lehmann & Associates
P.O. Box 566, Maumee, Ohio
(419) 891-0687

Circle 267 on inquiry card.

starts the Type-N-Talk speaking again. These commands are not sent to the display because they would be ignored anyway.

As I mentioned before, the two major parts of the Talker program are the relocation/initialization routine and the intercept routine. Descriptions of these routines follow (see listing 1).

The Relocation/Initialization Routine

The Talker program is loaded at hexadecimal 7000 (decimal 28672) and starts at 7010, which allows you to use the program on computers with 16K, 32K, or 48K bytes of memory without changes. The message in line 140 serves as a check on the date of the program. I have the program on several different disks and I find it helpful to have a clear ASCII (American National Standard Code for Information Interchange) date that I can read with DEBUG to ensure that I have the latest version.

First, the normal keyboard and display-driver addresses are taken from the vector locations and stored in the intercept program (lines 290 through 330). Next, the RS-232C interface is initialized, and the bps rate set to 9600 (lines 370 through 410). The program then turns off the retransmission mode of the synthesizer, which is normally used in daisy-chain configurations, by sending it the characters hexadecimal 1B and 14 (decimal 27 and 20).

The high-memory pointer determines how much memory is available for program use and is located at hexadecimal 4049 (decimal 16457) for the Model I and 4411 (decimal 17425) for the Model III. The program automatically finds which computer is being used by looking into the ROM (read-only memory) at location 0050 (decimal 80), where the special character table is located in Model I for keyboard decoding. If the byte stored there is hexadecimal 0D, you have a Model I; if not it's a Model III (lines 530 through 570). I have included this capability because I regularly run the program on both computers, and it is a nuisance to keep changing the pointer address

THE BENCHMARK[®]

- Word Processor
- Spelling Checker
- Graphics Package
- Mail List
- Financial Planner
- Data Manager
- Telecom

A Family of Highly Developed Software for Your Personal Computer

WE KEEP GOOD COMPANY

Dealers

Liberty Computer Sales
Tempe, AZ
(602) 949-8218
(800) 328-8905 outside AZ

Compusales
Lawndale, CA
(213) 370-3224

K.J. Murphy & Company
San Francisco, CA
(415) 391-5950

Compumax
Gainesville, FL
(904) 375-7737

Advanced Business

Systems of Jax
Jacksonville, FL
(904) 396-4414

InfoSystems, Inc.
Tampa, FL
(813) 223-5266

Atlanta Software House
Decatur, GA
(404) 292-2146

Major Mill, Inc.
Glenwood, IL
(312) 755-2500

Ellis Word Processing
Convington, KY
(606) 356-8642

Southern Computer Systems
Shelbyville, KY
(502) 633-5639

Computer Power International
Westwego, LA
(504) 436-9517

Soft Supply & Systems
Burlington, MA
(617) 229-6666

Invent Software, Inc.
Mineola, Long Island
(516) 294-7670
Computerland of Durham
Durham, NC
(919) 493-5402

J.A.M. Computers, Inc.
Long Island, NY
(516) 543-3770

Legal Computer
Applications, Inc.
Long Island, NY
(516) 488-3338

Haslba/Harris Assoc.
New York, NY
(212) 929-0104

Advanced Data
Technology Corporation
Greenville, OH
(513) 548-7747

Resource Control Group
Newtown Square, PA
(215) 359-1810

Odin Information Systems
Florence, SC
(803) 665-0000

The Software Place
Austin, TX
(512) 453-0851

Houston, TX
(713) 781-1488

Marshall Business Equipment
Marshall, TX
(214) 938-8371

Business Computer
Systems, Inc.
Salt Lake City, UT
(801) 967-0820

H & H Computer
Enterprises, Inc.
Blacksburg, VA
(703) 552-0599

micro MAX
Reston/Herndon, VA
(703) 471-4156

Byte Size Solutions, Inc.
Seattle, WA
(206) 783-9599

Total Computer Center
Washington, D.C., Metro
(703) 836-8188

faxx Computer Center
Langley, B.C. Canada
(604) 535-5337

Vancouver, B.C. Canada
(604) 875-1221

Distributors
Electrical Equipment Company
Phoenix, AZ
(602) 275-7801

SoftwareLand
Phoenix, AZ
(602) 279-9566

Scottsdale, AZ
(602) 248-8080

Mesa, AZ
(602) 834-8080

Western Information
Systems, Inc.
Phoenix, AZ
(800) 824-3086

GKE Software
Los Gatos, CA
(408) 354-5010

Software Resources
San Rafael, CA
(800) 851-9009

(800) 851-9010 outside CA
Standard Data Corp.
Ft. Lauderdale, FL
(305) 776-7177

Computer Management, Inc.
Atlanta, GA
(404) 231-1221

Van Ausdall & Farrar Inc.
Evansville, IN
(812) 424-5736

Fort Wayne, IN
(219) 432-1547

Indianapolis, IN
(317) 634-2913

South Bend, IN
(219) 289-4006

Soft Source, Division of
Continental Resources
Boston Metro, MA
(617) 275-2175

K.R. Computing
St. Louis, MO
(314) 721-3168

Professional Automated
Systems, Inc.
Columbus, OH
(614) 890-1095

(800) 231-1367 outside OH
Micro-Ware Hardware &
Software Distributors
Waterloo, Ontario
(519) 884-4541

Lone Star Micro, Inc.
Dallas, TX
(214) 521-2931

(800) 527-5078 outside TX
Futech International Corporation
Grand Prairie, TX
(214) 660-1955

Northern Shield
Willowdale, Toronto
(416) 225-5835

The Benchmark is a federally registered trademark of Metasoft Corporation.

Metasoft Corporation • 6509 West Frye Rd. • Chandler, Ariz. 85224 • (602) 961-0003 • (800) 621-1908

Circle 291 on inquiry card.

www.americanradiohistory.com

back and forth. If the program was to be run on only one or the other, this check could be eliminated, but because this part of the program eventually is discarded, the extra memory use is not a factor. Once the model type is determined, the length of the intercept routine (LAST-BEGIN = 436 bytes) is subtracted from the existing high-memory pointer, and this new address becomes the end of usable memory and is stored in the pointer location (lines 590 through 670). The intercept routine starts at this address plus 1 byte when it is relocated. For example, if the high-memory pointer were 32767, it would become 32767 - 436 or 32331, and the intercept routine would start at 32332 when it was relocated.

The difference between the new starting address (32332 in the example) and the present starting address (hexadecimal 7200 or decimal 29184) of the intercept routine is then calculated. Now various absolute addresses (subroutine calls and flag register addresses) are adjusted to reflect the new location (lines 760 through 1150), and the new locations of the keyboard and display intercepts are written back into the driver vector locations (lines 1200 through 1260). At last the intercept routine is transferred to the new location. The HL register pair is then loaded with the address of a DOS command string, and a jump to NEWDOS automatically starts execution of a BASIC program called "Date," a program I wrote that asks for the date from the operator, reads it back in English, and then runs a menu of available programs.

Remember that I promised to give a chaining routine for TRSDOS if you read far enough? Well, lines 1470 through 1950 do just that. Instead of the keyboard intercept vector being immediately loaded in the driver location, it is stored temporarily, and the location of a keyboard chain routine set in the driver vector's place. Whenever the keyboard is called, this new routine sends back a character instead. It types in "BASIC," answers the NUMBER OF FILES? and MEMORY SIZE? questions, and types in the name of the BASIC program to be

run automatically. Before returning with the last character, however, it replaces the keyboard driver vector with the address of the keyboard intercept routine. If you use this chaining routine, remember to assemble it in place of lines 1200 through 1400 and insert the name of the program to be run in place of Date.

The relocation and initialization are now complete, and this part of the program can be written over by BASIC.

The Intercept Routines

For clarity, the intercept routines are broken into three parts: the keyboard intercept, the video intercept, and their partner, the Find routine. Remember that, although listing 1 shows the program assembled at hexadecimal 7200 (decimal 29184), it is actually residing at the end of high memory.

The Find routine sends a character to the synthesizer or translates it into a word and transmits it.

The routine that echoes the keyboard is called, as you might suspect, Echo. This routine first calls the original keyboard routine to get a character.

Now the fun begins. First the character is checked to see if it is a null (00), which would indicate that no key had been pressed (lines 2150 through 2160). If this is the case, the program returns immediately to the host program as it normally would. If there is a character, it is then compared to hexadecimal 60 (the shift @ key), which is used to toggle Talker on and off (lines 2200 through 2210). If it is the hexadecimal 60, the routine jumps to lines 2490 through 2550 to turn on Talker; otherwise the TOGGLE flag register is checked to see if Talker has already been turned off (lines 2230 through 2250). Assuming that Talker is still on, the routine saves the character in the LAST CHARACTER register and sets the

KEYBOARD flag register (lines 2270 through 2310). The video-intercept routine uses these registers to prevent repetition of a character sent to the display after being input from the keyboard. Next, bit 7 of the LETTER flag register is set to make sure that all punctuation is spoken even though the PUNCTUATION OFF mode has been selected (lines 2330 through 2350).

The character is then passed to the Find routine, which either sends it directly to the synthesizer or translates it into a word and transmits it. Upon return from this routine, a test checks whether the last character sent to Type-N-Talk was a carriage return (hexadecimal 0D), and if it was not, a carriage return is sent (lines 2400 through 2450). Finally, the original character from the keyboard is returned to the host program.

The video-intercept routine is straightforward in that you can intercept the character on its way to the display, but many decisions and assumptions must be made before the job is complete. First, the condition codes must be examined to determine if the video driver was called to read a character already on the display. The carry flag indicates this condition and, if that flag is set, the routine continues directly to the video-display driver (line 2680). Assuming that the host program is really trying to write something on the display, the intercept routine next checks to see if the character is one of the special codes used to control Talker (see table 1) and, if it is, the appropriate action is taken (lines 2700 through 2920). The intercept routine returns directly to the host program when these codes occur because they are ignored by the normal display routine.

If the character is not a control code, the Distlk (display talker) subroutine is called. This routine first tests the TOGGLE flag register to see if the Votrax unit is still talking and returns to the host program if the unit is quiet (lines 3050 through 3070). The character in the LAST CHARACTER register is removed and saved temporarily (you'll need it later), and a space (hexadecimal 20)

COMPUTERSCOPE

USER PROGRAMABLE MULTIFUNCTION INSTRUMENT

by RC ELECTRONICS INC.

DIGITAL STORAGE OSCILLOSCOPE

SIGNAL AVERAGER

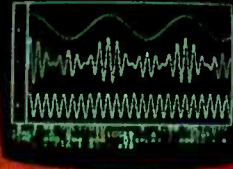
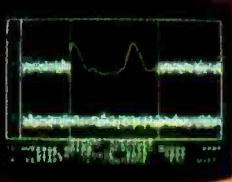

SPECTRUM ANALYZER

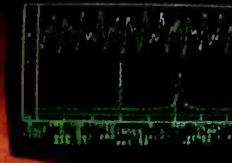

HISTOGRAM ANALYSIS PACKAGE

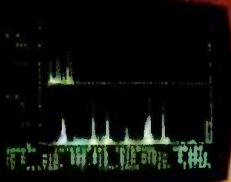

MULTIPLE TRACE DISPLAY

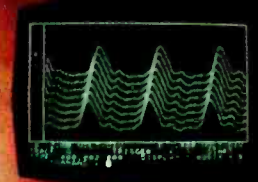

APPLE II COMPATIBLE

STRIP CHART
RECORD



PROGRAMMABLE
FUNCTION GENERATOR

DISK STORAGE



THE FIRST MULTIFUNCTION INSTRUMENT BASED ON A PERSONAL COMPUTER

Why pay for several different companies to design microprocessors into their instruments when we have upgraded a general-purpose microcomputer to accomplish the same tasks. R.C. Electronics has developed special hardware to give the **COMPUTERSCOPE** performance matching that of dedicated instruments with all the flexibility of a general-purpose computer. The **COMPUTERSCOPE** is hardware- and software-compatible with the Apple II, but with bonus features like a heavy-duty power supply and a 10-key pad for data entry.

For further information on the **COMPUTERSCOPE's** capabilities, contact R.C. Electronics for the name of your local representative.

5386 HOLLISTER AVE. • SANTA BARBARA, CA 93111 • (805) 964-6708
Telex 295281

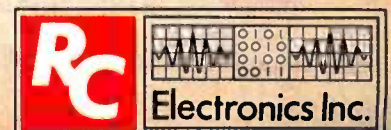

Product demonstration circle #391. General information circle #392. (SEE US AT WESCON BOOTH #4200)

www.americanradiohistory.com

is stored in its place. The character to be displayed is then tested, and if it is a space-compression code (hexadecimal C0 through FF, decimal 192 through 255), a space is sent to the synthesizer, and the compression code is sent on to the display (lines 3090 through 3140). If it is not, the new character is put in the LAST CHARACTER register for subsequent reference.

The next section (lines 3170 through 3230) eliminates repetition of a character that has just been input from the keyboard. If the keyboard flag register is not 0 and the new and last characters are the same, the new character is ignored. (There is a possibility, of course, that the last character from the keyboard was never sent to the display and that this character is the first letter of a new prompt. Unfortunately, if this is the case, the second one will still be ignored.)

The next test determines whether the new character is a control code to the display (TAB or BACK SPACE, for example), in which case a carriage

return is sent to the synthesizer. Otherwise, the program determines whether the host program is sending consecutive spaces and, if so, it ignores all but the first one. Here, execution jumps to line 3410 if the new character is not a space. If it is a space, it is compared with the last character to see if you just sent one. If you did not, you send it along to the synthesizer. Otherwise, to prevent sending lines of nothing, you must test the SPACE FLAG register, which, when it is not 0, indicates that at least two consecutive spaces have occurred. If it is 0, you set it and send a carriage return; otherwise, you ignore the space and return (lines 3250 through 3390).

Assuming that execution reaches line 3410, you clear the SPACE FLAG register, and the character or the word for it is sent to the Type-N-Talk by the Find routine (lines 3410 through 3420). The Find routine provides the return and, after clearing the carry (which you may have set), the character is sent on to the original video driver and then home to the

host program (lines 2990 through 3010).

The Find Routine

The Find routine checks an incoming character to see if it is a letter or number, translates it if it is not, and sends it to the synthesizer. (Refer to table 2 for the characters that are translated.) Lines 3500 through 3720 do the actual testing. If the character is greater than hexadecimal 7B, it is ignored, and 5B (up arrow) is the only character recognized between the uppercase and lowercase letter sets, so if the character falls between hexadecimal 41 (A) and 7A (z), it is transmitted directly. The numbers are handled similarly, and everything else must be made into a word before it can be sent. The translation is done (only if permitted by the LETTER flag) by looking up the character in the table, which is located at lines 4520 through 5850. This is done in lines 3800 through 3980.

A word about the table is in order at this point. First, some misspellings are evident. This is done intentionally



VILLAGE DATA CENTER
P.O. BOX 603
JOSHUA TREE, CA 92252

Choose from Our Menu
Monday-Friday
8:00 AM — 5:00 PM

Our sales staff is happy to take your order.

- #1. Medical
- #2. Dental
- #3. CA9 Programs
- #4. Construction Accounting
- #5. School Administration
- #6. Word Processing
- #7. General Accounting

The above items are now being served for connoisseurs of the Apple and IBM PC Computers.

To make reservations, or to inquire about our weekly SPECIALS.



Call
(619) 365-6668



Smart

THE GIFT

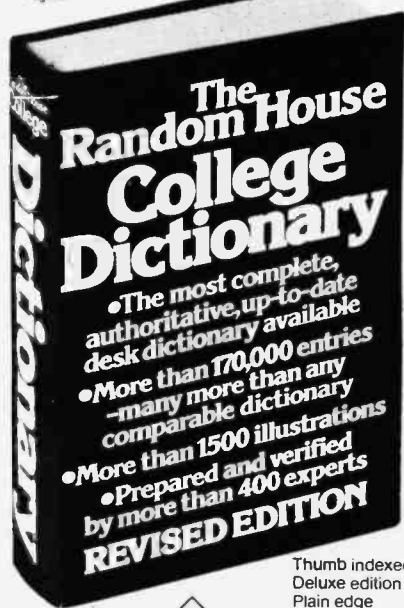

The Random House College Dictionary

- The most complete, authoritative, up-to-date desk dictionary available
- More than 170,000 entries — many more than any comparable dictionary
- More than 1500 illustrations
- Prepared and verified by more than 400 experts

REVISED EDITION

Thumb indexed \$14.95
Deluxe edition \$15.95
Plain edge \$13.95

Now at your bookstore  **RANDOM HOUSE**

Publishers of *The Random House Dictionary of the English Language. Unabridged Edition*

THE NEW STANDARD. THE MICROSOFT MOUSE.

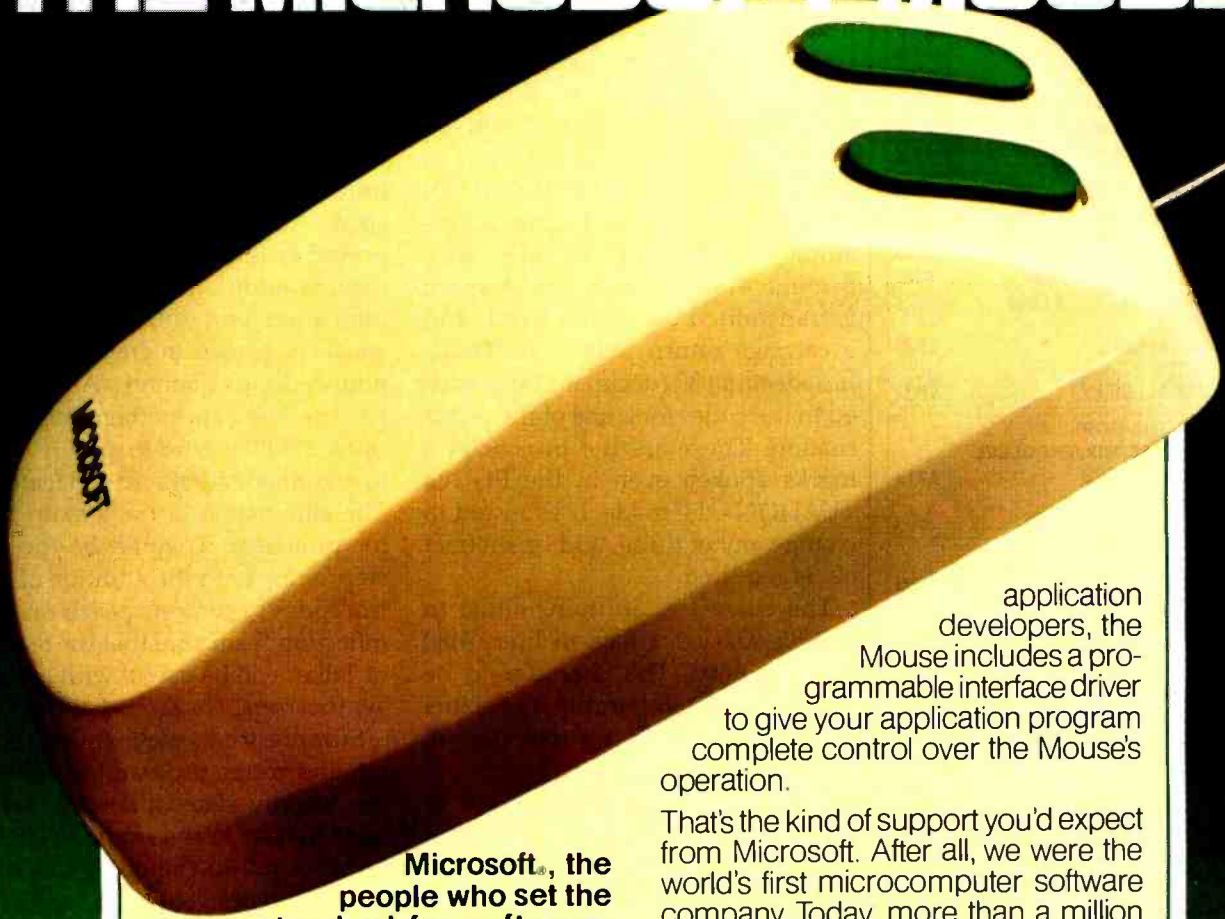

Microsoft®, the people who set the standard for software, have done it again with the Microsoft Mouse.

Our expertise in both hardware and software has gone into the development of the Microsoft Mouse. Now you can plug in the most exciting computer product of the year and put it to work.

The Mouse lets you move the cursor freely and naturally, then execute commands at the push of a button.

The Microsoft Mouse is a complete system. It comes with an on-screen tutorial, a practice application, and the Multi-Tool™ Notepad, a mouse-based text editor, so you can begin using the Mouse right away. And for

application developers, the Mouse includes a programmable interface driver to give your application program complete control over the Mouse's operation.

That's the kind of support you'd expect from Microsoft. After all, we were the world's first microcomputer software company. Today, more than a million microcomputers are running Microsoft-languages, operating systems, application programs, and hardware-software combinations.

You can get the Microsoft Mouse in either a bus or serial version for the IBM® PC or PC XT.

Ask your Microsoft dealer for a demonstration of the Microsoft Mouse — a whole new standard.



BETTER TOOLS FOR MICROCOMPUTERS

MICROSOFT™

Microsoft is a registered trademark, and MS and the Microsoft logo are trademarks of Microsoft Corporation.

**!!!!COMPETITIVE PRICES!!!!
FROM DIGITAL DIMENSIONS**

FOR THE IBM P.C.

FULL AST LINE.....	CALL
NEC Spinwriter 3550..33CPS.....	\$1,990
NEC 8023A.....	\$415
Quadram Quadboard w/64K.....	\$320
Quadram Quadboard w/128K.....	\$380
Quadram Quadboard w/192K.....	\$430
Quadram Quadboard w/256K.....	\$490

64K UPGRADE KITS.....	\$58
------------------------------	-------------

OKIDATA

ML-80.....	\$317	ML-82A.....	\$395
ML-83A.....	\$639	ML-84P.....	\$969
ML-84S.....	\$1,083		
ML-92..80 COL., 160 CPS PARALLEL.....	\$509		
ML-93..136 COL., 160 CPS PARALLEL.....	\$832		

THE GORILLA

SEIKOSHA DOT MATRIX, PARALLEL	
50 CPS PLUS GRAPHICS.....	\$219
MONITOR HI RES 12"	
NON GLARE GREEN.....	\$95

INFO RUNNER RITEMAN

120 CPS, FRICTION, PIN & TRACTOR FEED ALL STANDARD.....	\$339
--	-------

IDS

PRISM 80..3.4K & 200 Sprint.....	\$1,036
Inc. sheet feed, color & graphics.....	\$1,429
PRISM 132..3.4K & 200 Sprint.....	\$1,195
Inc. sheet feed, color & graphics.....	\$1,591
MICROPRISM 480.....	\$569

DIABLO

Diablo 620.....	\$989
Diablo 630.....	\$1,915

QUME

1140+ 40 CPS.....	\$1490
-------------------	--------

C. ITOH

Prowriter..80 Col., 120 CPS, Parallel..	\$396
Prowriter 2..80 Col., 120 CPS, Parallel.....	\$696
Starwriter F-10..40 CPS, Parallel.....	\$1,149
Printmaster F-10..55 CPS.....	\$1,489
8600 B 90 CPS Hi Res.....	\$1,119

MODEMS

Hayes 300 Baud Smart Modem.....	\$219
Hayes 1200 Baud Smart Modem.....	\$515
Hayes Integrated Modem for the IBM PC.....	\$499

MONITORS

Taxan	
RGB I - Med. res. color.....	\$309
RGB III - High res. for the IBM and Apple III.....	\$509
Green Phosphor.....	\$129
Amber.....	\$129
Amdek	
Color I.....	\$309
Color II.....	\$609

DIGITAL DIMENSIONS

190 Chapel Rd., Manchester, CT 06040

Info & Orders Call 203-649-3611
Orders Only 1-800-243-5222

All Prices Include UPS Ground Freight In U.S.
CT Residents Add 7 1/2% Sales Tax
Prices Subject To Change Without Notice.

to correct some pronunciation problems in the Type-N-Talk. Second, the terminating characters are denoted by adding hexadecimal 80 to the ASCII code for the last letter of the word. (Note that the table must start with hexadecimal 80 and end with 00). Unless this character happens to be A0, the word stops there. If it is A0, the next character is skipped, and the reading continues, enabling you to save space by using SEMI COLON for both semicolon and colon, for example. The routine in lines 4020 through 4130 sorts this out. A space is transmitted before the word, and a carriage return follows it. Third, hexadecimal 80 (decimal 128) is added to the codes for some of the punctuation. These are the punctuation marks spoken even in the PUNCTUATION OFF mode. If you want to change any of these, add or subtract 80 as required.

The characters are transmitted to the RS-232C interface in lines 4180 through 4400. The character to be sent is saved temporarily, the status of the RS-232C transmitter is checked, a delay is inserted to ensure that the Type-N-Talk has had time to turn off the CLEAR TO SEND line if it is talking, and the status of this line is tested. If everything is ready, the character is sent and the subroutine returns.

The flag registers (lines 4440 through 4480) are located just before the word table in memory and should be kept in that order because they are accessed by indexing the HL register pair. Eventually HL is left pointing at the start of the table. Note that if the TOGG register is set to 0 when the program is assembled, the Talker program will initially be off and must be turned on by the shift @ key or by sending 07 to the display. I use this to prevent the BASIC headers from being spoken while the system is being initialized. The PUNCTUATION ONLY mode may be similarly set by initializing the LTRFLG to 0.

New Speech Synthesizers

Since we purchased our Type-N-Talk, several improved synthesizers have appeared on the market. Votrax

has introduced a new model (and reduced the price of the old one), and Steve Ciarcia has published two articles in BYTE (September and October 1982) describing a unit called Microvox, which is available in kit form from Micromint Inc. and as a finished unit called the Intex-Talker from Intex Micro Systems Inc. In addition, a company called Street Electronics Corporation has released a unit called the Echo Speech Synthesizer. All of these units have improved text-to-speech algorithms and include additional features such as intonation and inflection, internal speakers, parallel interfaces, and pronounced punctuation. Although I have not used any of them yet, I don't think it will be hard to modify Talker to accommodate the added features. The elimination of the lookup table for punctuation would be the first step, along with the addition of control codes to control speech rate and inflection. I am sure that the features of Talker will be useful with the new synthesizers.

Suzanne wants me to finish a cooking and recipe program for her and has already stated that she doesn't want to have to run from the kitchen (downstairs) to the computer room (upstairs) when she is using it. This means that I will have to develop a remote terminal with another synthesizer that she can use in the kitchen, so I may get a chance to try out a new model, after all.

Conclusion

I was once told that if you give a job to a lazy man, he will get it done in the easiest possible manner. This program seems to justify that saying. Talker is a utility routine that loads itself automatically and makes vocal programs only a PRINT statement away. Now I can concentrate on the real task of satisfying my wife's growing demand for more and more programs that substitute speech for sight. ■

Heyward Williams is head of the Systems Engineering Department at Alpha Industries Inc. in Woburn, Massachusetts. He can be reached at 57 Franklin St., Derry, NH 03038.

**MACROTECH INTRODUCES ADIT
THE I/O WITH A MIND OF ITS OWN.**

Take a load off your CPU.

Our new ADIT DMA I/O boards, used in conjunction with our complete line of dynamic memory boards, can offer you extremely efficient expansion of your S-100 system.

A Z80B microprocessor provides on-board intelligence. ADIT features up to 16 channels per slot, full software compatibility, multi-mode operations and will make all your user ports good to the last byte.

Write or phone us for complete information about how ADIT 16-channel intelligent DMA I/O boards and Macrotech modular memory boards will increase the speed and capabilities of your system.

The Macrotech family of modular products includes:

*MAX 256
MAX 512
MAX 768
MAX-M*

*MAX 384
MAX 640
MAX 896
128ST*

and

ADIT. The intelligent solution to S-100 I/O

M **MACROTECH INTERNATIONAL CORP., 20630 Lassen St., Chatsworth, CA 91311 (213) 700-1501**

DEALER/DISTRIBUTORS: Priority One Electronics (800) 423-5922, (213) 709-5111 • Soft Machines (217) 351-7199 • IN ENGLAND: Fulcrum (Europe) (0621) 828-763

Circle 281 on inquiry card.

www.americanradiohistory.com



for a complete selection of microcomputer hardware, software and accessories.

ORYX SYSTEMS

QUALITY DISCOUNTS

APPLE/ FRANKLIN

ASHTON-TATE	
d-Base II	\$ 399
ASPEN SOFTWARE	
Grammatik	\$ 60
Proofreader	42
BEAGLE BROS.	
Apple Mechanic	\$ 22
DOS Boss	17
Utility City	22
BRODERBUND	
Bank Street Writer	\$ 55
General Ledger w/AP	305
Payroll	275
CDEX	
*Visicalc Training	\$ 45
CHARLES MANN	
Class Scheduling	299
CONTINENTAL SOFTWARE	
Home Accountant	\$ 55
DOW JONES	
Market Analyzer	\$ 279
Market Manager	240
Microscope	569

LOGO CORNER

Krell Logo	\$ 75
Abelson Book	15
Terrapin Logo w/full documentation	115

HAYDEN	
Pleewriter	\$ 108
HOWARD SOFTWARE	
Creative Financing	\$ 145
Real Estate Analyzer	145
LINK SYSTEMS	
Datafax	\$Call
DataLink	79
MICROPRO	
Wordstar (Special)	\$ 375
(w/CP/M Card, 70 col. & 64K	
Infostar (Includes CP-M/70 col/64K)	375
Pro Pak (WS/MM/SS/Index)	399
MICRO LAB	
Asset Manager	\$ 144
Invoice Factory	144
Payroll Manager	216
Tax Manager	129
Wall Streeter	216
MICROSOFT	
Cobol-80	\$ 499
Fortran-80	145
TASC Compiler	125
A.L.D.S.	99
Multiplan (DOS)	189
OMEGA	
Locksmith	\$ 75
Inspector	47
Watson	44

PEACHTREE (CP/M)	
Peachpak 40 G/L + A/R	
A/P (Special)	\$ 259
Series 40	
G/L, A/R, A/P ea.	195
Inventory	225
Series 9	
Peachcalc	279
Telecommunications	279
PENGUIN SOFTWARE	
Complete Graphics	\$ 53
Graphics Magician	45
Complete Graphics/Apple Tablet	86
Special Effects	50
SOFTECH	
Basic Compilers' Runtime	\$ 169
Softeach	94
UCSD p-system set	469
Xeno file	39
SOFTWARE PUBLISHING	
PFS: File	\$ 94
Graph Report	94
SUPERSOFT	
Basic Tutor	\$ 79
Fortran	325

SYSTEMS PLUS (Z80 req.)	
Landlord	375
VISICORP	
Visicalc (II or IIE)	\$ 179
Visischedule	225
CP/M SOFTWARE	
BYROM SOFTWARE	
*BSTAM	\$ 149
*BSTMS	149
COMPUVIEW	
*V-Edit 5080 Z80, IBM PC\$	130
*V-Edit CP/M86, MS DOS	160
DIGITAL RESEARCH	
*Pascal Mt + W/SP	\$ 389
MAC	85
SID (8080 Debugger)	68
ZSID (Z80 Debugger)	90
CP/M 2.2	140
C Basic 2	110
PL/1-80	425
INFOCOM	
*Deadline	\$ 39
*Starcross	32
*Suspended	39
*Zork I, II, III (each)	32
LEXISOFT	
*SpellBinder	\$ 275
MARK OF UNICORN	
*Final Word	\$ 239

d-BASE II CORNER

Ashton-Tate	
D-Base II	\$ Call
Bottom Line Strategist	299
FPL	475
Friday	225
Human Soft	
dB Plus	\$ 99
Fox & Geller	
Quick Code	\$225
D Unit	60
Software Banc	
d-Base II User's Guide:	
w/ d-Base II Purchase	\$ 15
w/o d-Base II Purchase	20
Anderson-Bell	
Abstat	\$349
Tylog Systems	
d-Base Window	\$206
*All above available on PC-DOS	

MICROPRO	
*WordStar	\$Call
*InfoStar	275
*Pro-Pack (WS/MM/SS Index)	\$Call

MICROSOFT	
Basic 80	\$ 249
Basic Compiler	289
Fortran 80	330
Cobol 80	499
Macro 80	150
MuMath/MuSimp	194
MuLisp/MuStar	156
*Multiplan	198

ORGANIC SOFTWARE	
*Datebook	229
*Milestone	229

PICKLES & TROUT	
CP/M for TRS-II	\$ 170

PRO/TEM SOFTWARE	
*Footnote	\$ 105

REVASCO	
Z80 Disassembler	\$ 85

SORCIM	
*Supercalc II	\$ 199
Superwriter (W/Speller & Mailer)	179



PEACHTREE CORNER

* PeachPak 4 (GL, AP, AR)	\$ 259
* General Ledger / Accounts Payable / Accounts Receivable / Sales Invoicing / Inventory Control / PeachPay Payroll	Each 399
* Peachtext	160
* Peachtext w/Random House Thesaurus	195
* Spelling Proofreader	95
* PeachCalc	90
* Job Cost System	399
* Client Posting & Accounting	399
* Graphics Language	275
* Business Graphic System	199

MICROSTUF	
*Crosstalk	\$ 135

NORTHWEST ANALYTICAL	
*Statpak	\$ 379

OASIS	
*The Word Plus	\$ 120
*Punctuation and Style	99

SELECT	
Select Word Processor	\$ 356

STAR COMPUTER SYSTEM	
G/L, A/R, A/P or Pay	\$ 350
*Legal Time, Billing	845
Property Management	845

Formats Available*

8" std, Altos Apple III/III, Cromenco, CP/M 86, Dec VT-80, Eagle, Heath/Zenith, Hewlett Packard 125, Micropolls/Vector Graphic, Northstar, Osborne, Otrona, Superbrain, Televideo, Xerox 820.
*Some Format Subject to "Download" fee

SUPERSOFT	
*Diagnostic II	\$ 90
Disk Doctor	75
*Fortran 4	305
Basic-8086	225
Lisp	120
Z8000 Assembler	400
C Cross Assembler	400
*ScratchPad	219

IBM/PC

Please see CP/M listing. All products with a "*" in front will also run on PCDOS and are priced the same.

ALPHA SOFTWARE	
Data Base Manager II	\$ 195
Mailing List	72
Executive Package	105
Type Faces	99
Question	35
Apple — IBM Connection	130

CENTRAL POINT	
Copy II PC	\$ 34

CONDOR III	
	\$365

CONTINENTAL	
Home Accountant	\$ 99

DIGITAL RESEARCH	
Concurrent CP/M 86	\$ 225
CP/M-86	50
Cobol 86	499
Pascal MT + 86 w/SPP	375
SPP 86	150
SID 86	113
C Basic 86	135

DOW JONES	
Market Analyzer	\$ 279

ECO-SOFT	
Microstat	\$ 230

GRAPHIC SOFTWARE	
Super Chartman II	\$ 299
Super Chartman IV	199
Both	350

LEXISOFT	
Spellbinder	\$ 259

LIFETREE	
Volkswriter	\$ 135

LOTUS 123	
	\$Call

PEACHTREE
Please see listing under CP/M.

Peachtext 5000 (Word processor, dictionary, spelling proofreader, PeachCalc electronic spreadsheet, list manager). FREE box of 5 1/4" diskettes and \$10 coupon for AccessPak (retail \$525).
All of the above . . . \$ 247

SUPERSOFT

C Compiler-8086	\$ 350
Star Edit	180
Disk Edit	80
Basic Compiler	325
Fortran IV PC/DOS	
or 8086	325
8087 Support	40
Diagnostics II	100
Optimizer	149
Personal Data Base	99
Investment Tax Pac	160
Scratch Pad	219

SYSTEMS PLUS

Landlord (prop. mgmt.)	\$ 375
Runtime Basic	
(req'd for above)	45
... and many more!	

**APPLE/
FRANKLIN
BOARDS**

ALS CP/M Card	\$ 299
ALS Smarterm	249
ALS Z-Card II	142
ABT Keypad	99
Axlon Ramdisk 128K	299
Bit 3 Dual Comm-plus	209
CCS 7710 Asynch Serial	119
East Side Wild Card	110
M & R Sup'r terminal	
80col.	249
Microsoft 16K Ramcard	72
Microsoft Softcard	245
Microsoft Softcard +	429
Microsoft Premium	
Softcard (Ile)	397
Softcard (Ile)	75
Microtek Printer I/F	195
Microtek Dumping-16	119
Microtek Dumping-GX	119
Mountain A-D/D-A	279
Mountain Music	
System w/Software	299
PCP 4 MHz Appli-Card	
+ 88 Card	599
PCP 88 Card 16 Bit +	
64K	475
Prometheus Versacard	159
Prometheus Graphitti	
Card	99
SSM ASIO Serial I/F	
w/cable	129
SSM AIO-2 4 Serial/	
Parallel	179
Street Echo II Speech	
Synth. I/F	129
Tymac Parallel I/F	
w/cable	79
Videx Display Enhancer	109
Videx Display	
Enhancer II	129
Videx Function Strip	69
Videx Videoterm VT-600	235
Videx Ultraterm	299
Wesper 16K Ram Card	69

**IBM/PC
BOARDS**

AST RESEARCH

ComboPlus 64K	
Clock/Calendar, Serial &	
Parallel, I/F, Expandable	
to 256K	\$287
MegaPlus 64K, Clock/	
Calendar, Serial Port,	
Expandable to 512K	
w/Megapak	287

Extra ports available for Megaplus and I/O Plus II includes Game, Parallel & Serial 35

Megapak 256K upgrade for Megaplus \$Call

I/O Plus II Clock/Calendar and Serial Port 118

BYAD DS-II

(64K, Z80, CP/M)	\$599
------------------	-------

MAYNARD ELECTRONICS

Floppy Drive Controller	\$185
Floppy Drive Controller	
w/Parallel or Serial	
Port	249
Sandstar Memory Card	
— 3 modules cap.	194
Sandstar Multifunction	
Card — 6 modules	
cap.	93
Sandstar Modules	\$Call

QUADRAM

Quadboard 64K, Clock/	
Calendar, Serial &	
Parallel Ports,	
Software	\$269
Microfazer Stack Printer	
Buffer (expandable to 512K)	
• Parallel/Parallel 8K	145
• Parallel/Parallel 64K	188
• Serial/Parallel 8K	170
• Serial/Serial 8K	189
Quadlink 64K Memory,	
Game port allows Apple	
Software to run	
on IBM/PC	\$Call

TECMAR Products \$Call

XEDEX/MICROLOG

Baby Blue	\$475
-----------	-------

TALL TREE

512K JRAM Mem.	
Board	\$699

MONITORS

Amdek Video 300A	
Amber	\$180
Amdek RGB	450
NEC 12" Hi-Res Green	187
Sanyo 12" Hi-Res Green	199
USI Hi-Res 12" Amber	169
NEC JB-1260 Green	99
PGS RGB Color	\$ Call
NEC JC-1203 RGB	560
Quadram Quadchrome	\$ Call
Taxan 12" Amber	149
Monitor	
Taxan 12" Green	136
Taxan 12" Medium RGB	323
Taxan 12" High RGB	512
Taxan RGB Cable	
for PC	17

MODEMS

Novation Apple-Cat II	\$269
Hayes Micromodem II	299
Anchor Mark I	84
Anchor Mark VII	129
Hayes Smartmodem	
300	\$205
Hayes Smartmodem	
1200	509

TELECOMMUNICATIONS CORNER

*****SPECIAL*****

Hayes Smartmodem 1200/Hayes Smartcom II Software	
AST I/O Plus II Clock Calendar and Serial Port	\$695
Above w/Smartmodem 300	415
Hayes Smartmodem 1200 & Smartcom II Software	579

Hayes Chronograph	189
Novation 212 Auto-Cat	585
US Robotics Auto-Dial	
(full auto 300/1200)	459
US Robotics Auto-Link	
(auto answer	
300/1200)	379
US Robotics Password	395

Star Micronics	
Gemini 15	489
GE Printers	\$ Call
Epson FX-80	599
Transtar T-130-P	725
Transtar T-315P Color	519
Mannesman Tally	
MT160	549

... and much more.

DISK DRIVES

Tandon TM-55-2	\$275
Tandon TM-100-2	240
Davong DSI-501 Hard	\$ Call

DISKETTES

3M 5" DS DD Box	\$ 31
BASF 5" DS DD Box	37
Maxell 5" DS DD	
MD2 Box	40
Verbatim 5" DS DD Box	35
Ultra Magnetics 5" DS,	
DD Bonus Box	
(12 diskettes)	35

DISPLAY CARDS CORNER

Hercules Graphics Board	\$369
Orchid Monochrome Graphic Adapter	432
Plantronics Colorplus	389
USJ Display Card (color/monochrome)	\$ Call
Amdek MAI Card	\$ Call
Tecmar Graphic Master	\$ Call

We offer the following complete systems w/full support on our technical line . . .

- Franklin 1000 & 1200
- Corona
- NEC APC & 8800
- Columbia
- Televideo

... please call.

PLOTTERS

Enter P100 Sweet P	
Apple/Franklin,	
IBM/PC	\$ 599
Strobe M100 Plotter	
w/I/F Apple/Franklin	499
Strobe M100 Plotter	
(RS 232)	539
Panasonic Digital	
Plotter	\$ Call

Miscellaneous

Koala Technologies	
Graphic Tablet	
w/Software,	
Apple, IBM/PC	\$ 99
Symtec Light Pen	
IBM/PC	\$ 140
Symtec High Pen	
Apple/Franklin	200
TG Joystick Apple/	
Franklin	49
TG Joystick IBM/PC	54
Versa VersaWriter	
Tablet IBM/PC,	
Apple/Franklin	259
Mouse Systems PC	
Mouse	229
Wico Analog Joystick	59
Wico Apple Adapter	18
Wico IBM/PC I/F Card	52
Keytronic Keyboard	
IBM/PC	209
Keytronic Keyboard	
Apple/Franklin	249
Curtis PC Products	\$ Call
Electronic Protection	
Series	\$ Call

CP/M is a registered trademark of Digital Research. IBM and the IBM logo are registered trademarks of International Business Machines. Apple and the Apple logo are registered trademarks of the Apple Computer Company. Franklin and the Franklin logo are trademarks of the Franklin Computer Company.

Please:

- Wisconsin residents — add 5% for sales tax.
- Add \$3.50 for shipping per software and light items. For multiple and other items, call.
- Foreign — add 15% handling & shipping for prepayment. (Int'l money order)
- Prices subject to change without notice.
- All items subject to availability.

Store prices are strictly retail.

ORYX SYSTEMS, INC.

205 Scott St. • P.O. Box 1961
Wausau, WI 54401

— Int'l. Telex
260181 ORYX SYS WAU

We welcome:

- Visa, Mastercharge & American Express — (Add 4%)
- Checks (Allow 1-2 weeks for clearing)
- COD (Add \$2.00 per shipment — Cash or certified check required)

Working Hours: Mon.-Th 8:30 - 5:30 • Fri. 8:30 - 6:30 •
Sat. 10:00 - 2:00 • Central Time

For technical information and
in Wisconsin: 715-848-2322

ORDER TOLL FREE OUTSIDE WISCONSIN 1-800-826-1589



Bitmaps Speed Data-Handling Tasks

Programming techniques employing bitmaps enhance the speed of list comparison and make short work of file searches

by Eric Sohr

Bitmaps are data structures that can speed data-handling tasks and reduce memory requirements in a variety of programming applications. Specifically, bitmaps—strings of 1s and 0s—can make short work of ordered-list comparisons and file searches.

This article describes programming techniques that evolved during the three years I spent developing a cross-indexing system called LITMAS (literature manipulation system). LITMAS uses bitmaps extensively for data handling and disk files; it runs on the 6502-based Apple II.

To present this material logically, I will begin by describing ordered lists and then bitmap representations of ordered lists. I will also illustrate the speed of bitmap operations when compared to alternative methods of processing and present the 6502 assembly-language coding and documentation. I will conclude with sections on bitmap compression.

Ordered Lists

For our purposes "ordered list" means a set of nonnegative integers such as $L_y = (y_1, y_2, y_3, y_4 \dots y_n)$, where each $y_i \geq 0$ and where $y_1 < y_2 < y_3 < y_4 \dots < y_n$.

For example, (1, 8, 16, 21) is an ordered list, while (1, 16, 8, 21) is a set that contains exactly the same elements but is not an ordered list. The elements 16 and 8 are out of sequence in the second set.

Ordered lists are often useful in computer operations. The ordering sequence minimizes the number of tests that must be performed when comparing one list with another. Suppose, for example, that you want to find the common members of two lists: $L_x = (X_1, X_2, X_3, X_4 \dots X_m)$ and $L_y = (Y_1, Y_2, Y_3, Y_4 \dots Y_n)$. If the sets are not ordered, you must choose one set and compare each member of that set with each member of the second set. If there are m members of the first set and n members of the second set, you must perform $m \times n$ comparisons between list members. If, however, the two sets are ordered, you need only perform $m+n$ comparisons. Ordering permits you to read each set only once to determine common items. Sorting techniques and algorithms are important research topics because of the time savings possible after the creation of ordered lists. A guarantee of ordering permits critical shortcuts in finding, inserting, and deleting members of a list.

An Algorithm for Examining Two Sequential Lists

The following algorithm can compare two ordered lists. The lists in this case are:

List 1 = $L_x = (X_1, X_2, X_3, X_4 \dots X_m)$

List 2 = $L_y = (Y_1, Y_2, Y_3, Y_4 \dots Y_n)$

In computer implementations of this algorithm, two memory locations serve as counters: a is the counter for L_x and b is the counter for L_y . The comparison is completed as soon as the algorithm has operated on all of the elements in either List 1 or List 2, i.e., when either a exceeds m or b exceeds n . Assume that each list has at least one member. The algorithm steps are:

1. $a=0, b=0$ —Set the counters for each list to an initial value of zero.
2. $a = a+1 : b = b+1$ —Increment the list counters.
3. If $a > m$, then quit—If a exceeds m , then there are no more members of L_x .
4. If $b > n$, then quit—If b exceeds n , then there are no more members of L_y .
5. Read X_a : Read Y_b —Read the next member of each list.
6. If $X_a = Y_b$, then go to step 16—A match. Add this value to the answer list.

(If step 6 fails, no match is found and either X_a or Y_b is larger than the other. After determining which list contains the smaller value, increment the counter for that list and read the next item in the list.)

7. If $X_a < Y_b$, then go to step 12—If true, then X_a is smaller, and the next member of L_x should be read.

(If step 7 is not true, then Y_b must be less than X_a . Therefore, increment b and read the next member of L_y .)

8. $b = b + 1$ —Increment the counter for L_y .
9. If $b > n$, then quit—If b exceeds n , then the entire list has been read.
10. Read Y_b —Read the b^{th} member of list L_y .
11. Go to step 6—Do comparison.
12. $a = a + 1$ —Increment the counter for list L_x .
13. If $a > m$, then quit—If a exceeds m , then the entire list has been read.
14. Read X_a —Read a^{th} member of list L_x .
15. Go to step 6—Do comparison.
16. Write the value X_a in answer list—Update the answer list. Either X_a or Y_b can be chosen since they are equal. (No discussion in the manner in which answer list is maintained is presented here.)
17. Go to step 2—Get the next list members.

Notice that each list member is examined one time and that the answer list is always ordered.

This algorithm performs set intersection. A similar algorithm can be devised to do set union. The intersection of two sets is the set that contains items common to both sets. The union of two sets is the set of items contained in one, the other, or both lists.

Notice that a single step in the algorithm—step 6—compares the two values in each list. The remainder of the algorithm is bookkeeping—testing for the end of lists and determining which list counter, a or b , should be incremented. Another method of comparison using bitmaps affords the opportunity to use machine-language instructions to find the intersection and union of two ordered lists.

Bitmaps

A bitmap is a string of 1s and 0s. Each member of the bitmap has a position and a value, and each posi-

tion in the bitmap can take on the value 0 or 1. A bitmap of length 8 (a byte of memory) can represent any ordered list of the integers 0 through 7. A value of 1 in a bitmap position means that the integer corresponding to that position is included in the list; a 0 in that position means that the integer is not included in the ordered list. The bitmap 10001001 thus stands for the ordered list (0, 4, 7) (see table 1). Table 2 provides some other examples.

A single byte can be used to represent an ordered list of from 0 to 8 elements in the range of integers 0 to 7. Thus, the ordered lists () and (0, 1, 2, 3, 4, 5, 6, 7) can be represented by a single byte, as table 2 shows.

In some cases, bitmaps may represent a memory savings over alternative methods of representing an ordered list. I will have more to say about such memory requirements when I discuss compression of bitmaps.

Bitmaps for Comparisons

Bitmaps provide an elegant method for comparing ordered lists. This method relies on the powerful AND and OR Boolean operations found in most machine languages. The results of the AND operation on 2 bits equals 0 unless both bits are 1, and the result of the OR operation on 2 bits equals 1 unless both bits are 0. Table 3 shows the AND and OR operations performed on bitmap representations of the two lists (0, 2, 5, 7) and (1, 3, 5, 6).

If you are unfamiliar with Boolean operations, look closely at table 3. A bit-by-bit operation has been performed vertically. Notice that the results are ordered lists. Hundreds of machine cycles would have been required to solve these problems using a standard algorithm. (For example, try using the 17-step comparison algorithm to find the intersection of the two lists in table 3, keeping track of the number of increments and comparisons.) An assembly-language program to solve the same problems using bitmaps is much faster. If location A contains a bitmap representation of (0, 2, 5, 7) and location B contains a bitmap representation of (1, 3,

01234567—Position (0 through 7)
10001001—Value (0 or 1)

Table 1: The bitmap 10001001, which represents the ordered list (0, 4, 7).

Bitmap	List
00010001	(3, 7)
11100001	(0, 1, 2, 7)
00111100	(2, 3, 4, 5)
00000000	() (List with no members)
11111111	(0, 1, 2, 3, 4, 5, 6, 7)

Table 2: Bitmap examples and the corresponding lists.

a. The intersection of two sets.

	Bitmap	List
Input	10100101	— (0, 2, 5, 7)
	AND	
	01010110	— (1, 3, 5, 6)
	—	
Result	00000100	— (5)

b. The union of two sets.

	Bitmap	List
Input	10100101	— (0, 2, 5, 7)
	OR	
	01010110	— (1, 3, 5, 6)
Result	11110111	— (0, 1, 2, 3, 5, 6, 7)

Table 3: Boolean operations on the bitmap representations of two lists: (0, 2, 5, 7) and (1, 3, 5, 6). The bit-by-bit AND operation (a) yields a bit representing the intersection of the sets of elements in the two input lists; the OR operation (b) yields a bitmap representing the union of the two input lists.

5, 6), then a two-step program performs the intersection:

```
LDA A
AND B
```

The first of these two statements loads the accumulator with the contents of A. The second statement performs an AND on the contents of the accumulator with the contents of memory location B. Only three machine cycles are required for each instruction, using a 6502 microprocessor. Eight machine cycles are

Listing 1: The assembly-language code that performs the intersection of two 256-byte ordered lists.

```

LDX #0          Load the X register with 0.
LOOP LDA A,X     Load the accumulator with the contents of address A
                modified by register X. The actual address to be used is A
                + the contents of the X register.
AND B,X         Perform an AND on the contents of the accumulator with the
                contents of the address B modified by register X.
STA C,X         Store the result of the AND operation in the memory location
                C modified by register X.
INX             Increment the X register, i.e., add 1 to the existing contents
                of the X register.
CPX #0         Compare contents of X register with number 0. In the 6502,
                a wraparound occurs when the value 255 is incremented, i.e.,
                255 + 1 = 0.
BNE LOOP       If the comparison of X with 0 is not equal to 0, then go to
                LOOP.
    
```

Merely replace the instruction AND B,X with ORA B,X (perform an OR on the contents of the accumulator with the contents of location B modified by register X).

Use of Bitmaps

Perhaps the most familiar use of bitmaps in home microcomputers is in the disk operating system (DOS), in which each sector on a disk is given a particular position in a bitmap. The use of a 1 in that place means that the sector is free and able to be used for a new file. The use of a 0 in that place means that the sector has been used and is unavailable for a new file. In the DOS application, there are only two possible values for a sector, either used or unused—a binary attribute.

A particular database may contain several binary attributes that can be handled with bitmap representations. Take, for example, a personnel file for a corporation that has extensive European operations. Table 4 illustrates the bitmap representation of such a file, and table 5 details the file's construction for five employees.

Based on the table 5 data, employee 1 is an unmarried male with a college degree who can type and who speaks French and German but not Italian or Russian. Employee 2 is a married female without a college degree who can type and who speaks Russian but not French, German, or Italian. Employee 3 is a married female with a college degree who does not type and who speaks French, Italian, and Russian but not German.

Notice that the table 5 structure is a matrix. The characteristics for an employee are stored horizontally. The vertical representation is also interesting. Looking down the Typist column, note that employees 1, 2, and 4 can type. Also notice that employees 2, 3, and 5 speak Russian, and so on. The columns are examples of inverted lists. The inverted lists in the personnel file enable the manager to easily find employees who have certain skills.

Because the columns of the matrix form a bitmap, the AND and OR operations can be used on the col-

Bitmap Position	Abbreviation	Attribute
0	SEX	0 = MALE 1 = FEMALE
1	MAR	0 = UNMARRIED 1 = MARRIED
2	TYP	0 = DOES NOT TYPE 1 = TYPES
3	COL	0 = NOT COLLEGE GRAD 1 = COLLEGE GRAD
4	FRN	0 = NOT FRENCH SPEAKING 1 = SPEAKS FRENCH
5	GER	0 = NOT GERMAN SPEAKING 1 = SPEAKS GERMAN
6	ITL	0 = NOT ITALIAN SPEAKING 1 = SPEAKS ITALIAN
7	RUS	0 = NOT RUSSIAN SPEAKING 1 = SPEAKS RUSSIAN

Table 4: The bitmap representation of an employee file.

Bitmap Abbreviation—	SEX	MAR	TYP	COL	FRN	GER	ITL	RUS
Employee 1	0	0	1	1	1	1	0	0
Employee 2	1	1	1	0	0	0	0	1
Employee 3	1	1	0	1	1	0	1	1
Employee 4	0	0	1	1	0	1	1	0
Employee 5	1	1	0	0	1	1	0	1

Table 5: The bitmap construction for a personnel file. The abbreviations are defined in table 4.

needed to compare bitmaps as opposed to hundreds of machine cycles required to compare ordered lists represented in some other fashion.

A bitmap of length 8 is not a particularly exciting data structure because it is limited to the integers 0 to 7. However, by using a page of memory (256 bytes × 8 bits/byte = 2048 bits), we can use bitmaps to represent ordered lists for the integers 0 to 2047. Here we see the possibilities

for a much more powerful data structure.

In extending our single-byte example for intersection, we will use two ordered lists of 256 bytes. The first list begins at location A and the second at location B. We wish to store the intersection beginning at location C. The assembly-language code in listing 1 performs the intersection for A and B.

The union operation is analogous.

*For IBM

Computer Channel

Come Visit Us
In Our New York
City Showroom.

Our Speciality: 68000, 6809 CPU, graphic, database, communication, word processing



TELEVIDEO, VISUAL, IDS, OKIDATA, EPSON, HOUSTON INSTRUMENT

DYSAN, C.ITOH, TANDON, SWTPC, AMDEK, NEC, IBM, DEC, ESPRIT, QUME, GTCO, SANYO

COMPUTERS

CROMEMCO

Best Price
Anywhere

CS1D2E 256K RAM, 68000 & Z80... 4,396
CS1HD5E 512K RAM, 68000 & Z80
20MB hard disk, one 5 1/4"
floppy disk... 7,596

DUAL 68000 CPU, 80MB SMD hard
disk, intelligent I/O, UNIX, relational
database... CALL

WICAT 1 to 12 users, 68000 CPU, 256K to
4.5MB RAM, 10MB to 474MB hard
disk, graphic... 9,000 & up

North Star... CALL
SWTPC, HELIX, DYNABYTE, TERA... CALL

YOUR OWN PERSONAL ROBOT... 2,215

MODEMS

D.C. Hayes Smartmodem
300 baud... 230
1200/300 baud... 530
*1200B modem & SW... 470
USR Auto Link 1200... 450
UDS 212 LP... 400
212A... 595
Novation Smartcat 300... 200
Smartcat 300/1200... 455
J-Cat... 130

SOFTWARE

dBase II Ashton-Tate... 489
Redding Grftalk business graphics... 400
Async micro to mainframe... 100
Crosstalk Microstuf... 160
Accounting software
*Accounting Plus... 299
MBS1... CALL
CP AID MASTER TAX... CALL
*Peach pak (GL,AR,AP)... 331
Microsoft MULTIPLAN... 220
Word processing
I.U.S. Easy Writer II... 260
MultiMate *Word Processing... 375
IBM Concurrent CP/MS6 & package... CALL
Special on all IBM software

TERMINALS

Zenith Z-29 Smart terminal... 648
ZT-1 with modem... 488
Hazeltine Esprit II... 588
Esprit III... 665
Esprit III color terminal... 875
Televideo 925... 740
970... 1,099
Visual 50 white... 625
55 green w/functions... 725
550 graphic... 2,200
Wyse 100... 795
Viewpoint ADDS color terminal... CALL
QUME 102 excellent... 590

PC COMPUTERS

Epson QX-10 Computer
Complete system and software
(For local customer only)
Cromemco C-10... 1,490
Televideo, Morrow Design... CALL

IBM COMPATIBLE

Zenith
Z-110 Dual drives, 128K RAM,
8/16 bit, color board,
225 x 640 graphics... CALL
ZW-110-32 with 11MB hard disk... CALL
ZVM-135 RGB color monitor
640 x 480... 550

Corona
128K RAM, 320K floppy, 640 x 325 graphic,
green monitor ser. & par. port, DOS,
GW BASIC, MultiMate word processing, PC
Tutor... CALL

Eagle
128K RAM, two floppy disks, monitor, two
ser. & one par. ports, EagleWriter, EagleCalc,
MS-DOS, and CP/M-86... CALL

Columbia
128K RAM, two floppies, 2 Ser. & 1 par.
ports, software... CALL

Portable Computer
Corona PPC-1 128K RAM, one 320K
floppy, monitor, and serial
port... CALL
Columbia, Teletote... CALL
AST, Quadram, LNW cards... CALL

PRINTERS

BANANA 50 cps... 215
Microprism 110 cps, 84 x 84 graphic, pin &
friction feed, ser./par... 459
IDS 200 cps, 132 col... 1,100
Prism 132 with graphic... 1,180
with graphic, color, friction... 1,590
Gemini 10 100 cps... 339
15... 525
Epson FX-80 160 cps... CALL
FX-100... CALL
RX-80... CALL
Okidata ML 83A... 625
84 Par... 960
92... 520
93... 840
160 cps... 620
MT 160L 200 cps... 1,393
MT 160Z Prowriter I par... 410
C.ITOH 8600 two colors... 1,050
P1350... 1,525
Toshiba

Letter Quality

Dynax 15 13 cps excellent... 520
Brother HR-1 12 cps... 785
Silver Reed... 699
Transter 130... 727
Diablo 620... 985
C.ITOH F-10 Starwriter 40 cps... 1,185
NEC 7710, 7730... 2,150
3550 for IBM... 1,860
Qume 11+ 40 cps... 1,400

MONITORS

Zenith ZVM-123 12" green... 115
ZVM-122 12" Amber... 149
ZVM-131 medium resolution... 305
*ZVM-135 640 x 480... 550
color I 13"... 340
*color II RGB... 450
color IV 720 x 400... 1,070
NEC 12" green... 170
1203 RGB... 725
Taxan color monitor... 330
Amber... 149

PLOTTER/DIGITIZER

Houston Instrument DMP-29... 1,795
DMP-40... 795
DMP-41 & DMP-42... CALL
HIPAD DIGITIZER... CALL
Amdek XY plotter, 1 pen... 665
6 pens... 1,095
Sweet-P *Plotter... 610
GTCO *graphic analysis package
w/digitizer for IBM... 2,500

DISK DRIVES

\$390 MITSUBISHI

8" Double Sided/Double Density Flexible disk
drive Qume & Shugart Compatible
M2894-63 1.2MB drive... 390
Two M2894 drives, cabinet with power
supply
& fan (unassembled)... 1,099
8" dual M2894 drives subsystem
(assembled)... 1,130
Technical manual... 25
Dual drives signal cable... 50
Slimline bare drive 8" M2896... 410
(compatible w/Cromemco 64FDC & Zenith 100
computer)

TANDON

100-2... 260

QUME

Both full and half height... CALL

Prices subject to change. American Express, Visa/Mastercard
add 3%. F.O.B. point of shipment. 20% restocking fee for
returned merchandise. No return for software. Personal
checks take 3 weeks to clear. COD on certified check only.
N.Y. residents add sales tax. Manufacturers' warranty only.
International customers, please confirm price before order.
Accept P.O. from Fortune 500, schools and gov't.

For information CALL (212) 937-6363
To order CALL 1-800-331-3343

Computer Channel TELEX:
21-55 44th Road 429418
Long Island City, NY 11101 CSTNY

Employee Number	RUS	SEX	Intermediate Answer	COL	Answer
1	0	0	0	1	0
2	2	1	1	0	0
3	1	AND 1	1	AND 1	1
4	0	0	0	1	0
5	1	1	1	0	0

Table 6: The intersection of RUS, SEX, and COL columns of the table 5 bitmap construction. The answer indicates that only employee 3 is female, Russian-speaking, and a college graduate.

umn representations. For example, a female Russian-speaking college graduate can be found by performing the following intersection: RUS AND SEX AND COL. The intersections are done serially, as table 6 shows. First, the intersection of RUS and SEX is performed, then the resulting intersection answer is intersected with COL.

In the personnel-file example, a single bit represents the presence or absence of an attribute. This scheme may result in space saving when you're constructing a database

because you can use a single bit in place of an entire field within a record. The bitmap scheme also provides a time-saving method for retrieving records that match search criteria.

Extending Bitmaps to More Complex Systems

Bitmaps easily lend themselves to cross-indexing systems for literature. The LITMAS system, for example, creates a matrix similar to that presented for the personnel problem of the previous section. Instead of in-

dexing (or characterizing) employees, LITMAS characterizes an item such as a journal article, a client, or a 35mm slide. The attributes used for indexing are called keywords. LITMAS permits the definition of 512 items per disk (analogous to employees in the previous example) and 512 keywords (analogous to the column headings: SEX, COL, TYP). Any number of keywords may be attributed to an item. The power of bitmap searches becomes very evident in LITMAS, which can perform 60 intersections or unions on a file of 512 items in less than 20 seconds.

The examples discussed in the remainder of this article use a bitmap matrix of length 256. Although smaller than the LITMAS matrix, this matrix can demonstrate bitmap calculations while allowing a single byte to represent a position number. In extending our discussion to larger matrices, we will have the opportunity to discuss the techniques for modifying and compressing a bitmap.

The rows in our matrix are bitmaps

COMPETITIVE EDGE

Systems with CP/M® 80, CP/M-86, MP/M-86™, & MSDOS™ Operating Systems 64K to 1024K Main Memory, 1 MB to 40 MB Floppy & HD Storage, Single & Multi-user Systems.

Announcing Our Ultra Budget System: \$1895.00

10 Slot Integrand Cabinet with 4MHz Z80A, 64K, 2 Serial / 2 Par. Ports, (2) 8" Single-sided 1 MB Floppies & Spellbinder Wordprocessor. This System is shipped ready to boot and run and it is expandable to hard disk & up to 8 slaves. Yes, there is a special dealer price. . . .

Other Systems From Competitive Edge:

10MHz 68000, 128K, CP /M68K, (2) 8" 2.4MB Floppies	\$3895.
10MHz 8086, 128K, CP /M86, (2) 8" 2.4MB Floppies	3895.
10MHz 8086, 128K, MSDOS, (2) 8" 2.4MB Floppies	3925.
6MHz CPU Z, 64K, CP /M80, (2) 8" 2.4MB Floppies	2995.
6/8MHz 85/88, 64K, CP /M80, (2) 8" 2.4MB Floppies	3095.
Lomas S-100 PC, 128K, (2) 5" Floppies 15 Slot MB	2495.
Compupro® 816-C 3-User, 384K, 21MB HD	9895.
Compupro® 816-C 3-User, 384K, NO HARD DISK	6566.
Compupro® 816-68K 68000 CPU	6566.
Lomas 2-User MPM-86 256K, 8086/8089, (2) 8" 2.4MB	3895.
Lomas 5-User MPM-86 512K, 86/89, 32 MB HD	8095.
Teletex Systemmaster, (2) 8" 2MB, 10 Slot MB	2495.
22MB Hard Disk for Teletex	2295.

SEATTLE GAZELLE List 5995. SALE \$4695.

ADVANCED DIGITAL CALL

QUME 102 Terminal	\$535.	VISUAL 50	635.
TELEVIDEO 950	875.	TELEVIDEO 925	689.
EPSON FX80	545.	C. ITOH F10 40 CPS	1195.
DRI PASCAL MT + 86	425.	DRI "C" for CP/M-86	425.
Compupro Disk 1/CPM	445.	10MHz 8086 or 68000	621.
Compupro 80286 CPU	1164.	LOMAS 20286 CPU	CALL

CP/M, CP/M86, MP/M86 are either Trademarks or Registered Trademarks of Digital Research. Compupro is a Godbout Company.

P.O. Box 556, Plymouth, Michigan 48170

ORDERS ONLY: 1-800-336-1410 LOCAL & INFO: 313-451-0665

Peripherals/Software for Robots

HERO MEMCOM BOARD

This product provides a means to develop programs for the robot using a personal computer, and expands the robot's memory with an additional 30K of RAM. A large wire-wrapping area is also available on the board for user experimentation.

- Two 8-bit bi-directional parallel ports with handshaking lines for superfast data transfers between the robot and a computer (connects directly to our APPLE-HERO COMMUNICATOR board), plus two 16-bit timers.

- An RS232 serial port for two-way communications between the robot and a computer.

- Serial communications software in an onboard EPROM which allows uploading and downloading of programs

PRICE \$295.00

APPLE-HERO COMMUNICATOR

This product provides the hardware and software necessary to implement two-way high speed parallel communications between an APPLE® computer and a HERO robot equipped with our HERO MEMCOM BOARD.

- A peripheral card for an APPLE that contains two 8-bit parallel ports with handshaking lines, and two 16-bit timers.

- Data transfer software for the APPLE board and for the HERO MEMCOM BOARD burned into two 2716 EPROMs.

- A disk containing heavily commented 6808 and 6502 source codes for downloading and uploading of programs.

These source codes are compatible with the S-C MACRO ASSEMBLER and the S-C 6800 CROSS ASSEMBLER available for the APPLE from the S-C SOFTWARE CORPORATION.

PRICE \$159.00

MICROMATION INC.
9104 Red Branch Rd.
Columbia, MD 21045

For information call:
(301) 730-1237

COMPUTER HUT™

COMPARE
OUR
SERVICE & PRICE!

IBM-PC & XT
CALL FOR
PRICE

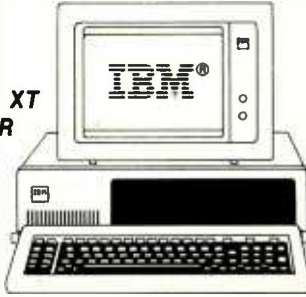

HARDWARE FOR IBM-PC DISK DRIVES

Tandon TM100-2 DS/DD \$239
TEAC FD-55B Slimline \$269
SHUGART SA-455 half-high \$259

MAYNARD ELECTRONICS

Floppy Disk Controller \$169
FDC w/Par. Port \$219
FDC w/Ser Port \$239

MK RESEARCH

Ram 64K to 512K + SP CALL
Multifunction + Ram TOO LOW TO
Color Graphics for IBM-PC PUBLISH

QUADRAM

Quadboard-PP, SP, C/C, Mem + s/w
64K..... \$295 256K..... \$439
Quad 512 + SP, Mem with s/w
64K..... \$249 512K..... \$659

MICROFAZER (print buffers)

ME8 Snap-on Epson/IBM \$129
ME64 Snap-on Epson/IBM \$229
MP8 P-P w/pause/copy \$139
MP64 P-P w/pause/copy \$229

AST RESEARCH

MegaPlus II 4-Funct 512K + s/w \$879
ComboPlus II 4-Funct 256K + s/w \$499

HERCULES

Hi Res Graphics 720 x 384,
PP, + s/w \$389

FREDRICKS ELECTRONICS

COLORPLUS 640 x 200,
16-Color + s/w \$369

MBI

Monte Carlo 5-Funct 64K-1M \$319

QCS

Big Blue 4-Funct + Z80 for CP/M
& hard disk I/F with s/w \$479

HARD DISK - IBM & APPLE

DAVONG, MOUNTAIN CALL

MODEMS — HAYES

Micromodem II for Apple II \$275
Micromodem II w/Term Prog \$319
Smartmodem 300 \$225
Smartmodem 1200 \$535

MONITORS

AMDEK
Video 300G... \$135 300A.... \$149
Video 310A \$165
Color I..... \$299 Color II.. \$449
Color III \$379

PRINCETON GRAPHIC SYSTEM

HX12 Hi Res RGB monitor.... \$509

SANYO, NEC CALL

PRINTERS

EPSON w/Graftrax
RX-80..... \$379 FX-80.... \$599
MX-80 F/T.... \$449 MX-100... \$649

brother®

HR1 A Par.... \$759 Ser..... \$859

C-ITOH

STARWRITER F-10 P or S \$1195
PROWRITER 8510 P \$399
PROWRITER 8510 S \$579
PROWRITER2 1550 P \$690
PROWRITER2 1550 S \$749

STAR MICRONICS star

Gemini 10X. \$329 Gemini 15. \$499

OKIDATA

82A..... \$419 83A..... \$689
84P..... \$1099 84S..... \$1199
92P..... \$525 92S..... \$609
93P..... \$949 93S..... \$1049

NEC, COMREX, IDS, DIABLO.. CALL



ACCESSORIES

Tractor feed, Ribbons, Printheads
Daisywheels, Diskettes..... CALL

SOFTWARE FOR IBM PC

WORDPROCESSING

WordStar.. \$299 Word Perfect \$329
MailMerge.. \$159 EasyWriter.. \$129
SpellStar.. \$159 Volkswriter.. \$129
EasySpeller II \$159
Select \$339

SPREADSHEET/GRAPH

Lotus 1-2-3. \$355 Multiplan... \$189
TK! Solver CALL Fast Graph.. \$189
SuperCalc II \$199 VisiCalc.... \$189
Visi Trend/Plot \$229

ACCT/FINANCIAL

Home Accountant Plus \$99
Eagle Money Decision \$129
Tax Manager \$179
Peach Pack (GL/AR/AP) \$369

DATA BASE MGT.

dBase II... \$429 EasyFiler... \$279
TIM III.... \$349 Quick Code.. \$219
Visi Dex... \$189 Visi File.... \$239

ANY S/W NOT LISTED? . CALL



Apple IIe
128K 80 col,
disk, monitor
CALL



HARDWARE FOR APPLE

MICROTEK

Dumpling-GX \$99 DMP-16.... \$179
BAM-16.... \$99 BAM-128.... \$349
RV611-C \$89

RH ELECTRONIC - Super Fan II.. \$59

ORANGE MICRO Grappler+ .. \$129

als

CPM/CARD \$319 Z-CARD.... \$135

SATURN

Ram - 32K \$169 Ram 64K.... \$299
Ram 128K \$429

PROMETHEUS

Versacard \$149
Graphitti Graphics \$99

DISKS DRIVES FOR APPLE

RANA Elite CALL
TAVA Data Drive
or Applette \$249

FULL LINE APPLE S/W CALL

Apple II + Compatible system CALL

DEC Rainbow 100 CALL

ANY PRODUCT NOT LISTED? CALL ASK ABOUT OUR REPAIR SERVICES

COMPUTER HUT ORDERS & INFORMATION ORDER-LINE ONLY

OF NEW ENGLAND INC.
101 Elm St., Nashua, NH 03060

(603)889-0666

(800) 525-5012

All products usually in stock for immediate shipment and carry full manufacturers' warranty. Price subject to change—this ad prepared two months in advance. You get the lowest price. We honor personal checks—allow 10 days to clear. COD up to \$300 add 3%. Visa, MasterCard add 3%. For shipping, insurance and handling add 2% or \$5.00 min. APO & FPO orders add 15%. Include phone number. Call (603) 889-0666 for a return authorization number prior to returning any material.

Apple is a trademark of Apple Computers Inc.

IBM is a trademark of IBM Corp.

Circle 109 on inquiry card.

Position	0 1 2 3 4 5 6 7	8 9 10 11 12 13 14 15	16 ... 247	248 249 250 251 252 253 254 255
Byte #	Byte 0	Byte 1	...	Byte 31
Bit # in Byte	7 6 5 4 3 2 1 0	7 6 5 4 3 2 1 0	7 ... 0	7 6 5 4 3 2 1 0
Bit Value	0 0 0 0 0 0 0 0	0 0 0 0 0 0 0 0	0 ... 0	0 0 0 0 0 0 0 0

Table 7: *Bitmap representation of items prior to indexing.*

of length 256; that is, positions 0 to 255 are represented. This representation requires 32 bytes (32 bytes × 8 bits/byte = 256 positions). Within LITMAS, each position in a bitmap row is associated with a user-defined keyword. Keyword number 0 is in position 0 of the bitmap; keyword number 1 is in position 1 of the bitmap, and so on. As a new item is indexed, the appropriate keyword positions are set from 0 to 1. Table 7 shows the bitmap representation before indexing.

The top row of table 7 specifies the position within the bitmap, 0 to 255, and the second row demonstrates the byte numbers corresponding to various bitmap positions. Byte 0 contains positions 0 through 7, while byte 1 contains positions 8 through 15, and so on. The third row shows the bit position within the byte. The high-order bit is 7 and the low-order bit is 0. The fourth row specifies a value of 0 in the bitmap row prior to indexing any item.

In order to flip a bit from 0 to 1 at

a particular position in the bitmap, it is necessary to locate the specific bit by tracing from position number to byte number and then to bit number within that byte.

Beginning with a bitmap of all 0s, it is necessary to change the 0s to 1s in those positions corresponding to the attributes to be associated with the item. Suppose a bitmap-position integer corresponding to such an attribute is contained in the POSN location. To determine the bit to be changed, you must determine the BYTE number and the BIT number within that BYTE. To find the BYTE and BIT numbers, divide POSN by 8. The integer result of this division, i.e., $BYTE = INTEGER (POSN/8)$, is the byte position in the bitmap. The remainder from the division, $REMAIN = POSN - (8 * BYTE)$, can be used with listing 2 and its code, which employs an OR operation to set the appropriate bit to 1.

To perform the operation, we can load the Y register with BYTE and the X register with REMAIN. We then ob-

tain the BYTE member of the bitmap and perform an OR with it and the REMAIN member of the TABLE and store the result back in the bitmap, as the listing 2 assembly-language code shows. The OR operation sets the desired bit to 1 while other bits within the byte retain their previous values.

In our calculation of BYTE and REMAIN we used quasi-BASIC code. In assembly language there is a quick way to determine the BYTE and REMAIN values. Because POSN is a single-byte integer, integer division by 2 is a right shift of the number, and division by 8 is three right shifts. The remainder, REMAIN, is the value of the 3 low-order bits of POSN, while the 5 high-order bits of POSN contain INTEGER.

Our calculations thus become easy in assembly language, as listing 3 illustrates.

Sparse Matrix Problem

It is clear that bitmaps are efficient for representing ordered lists when

Listing 2: *A method for setting a particular bitmap bit, given a byte number (the integer portion of a bitmap-position number divided by 8) and a remainder. (The table indicates the bit position to be set for a given remainder.)*

```
LDY BYTE      Load Y register with the value BYTE.
LDX REMAIN    Load X register with the value
              REMAIN.
LDA BITMAP,Y  Load accumulator with contents of the
              address bitmap modified by the Y
              register.
ORA TABLE,X  Perform an OR on the accumulator with
              the contents of TABLE modified by X
              register.
STA BITMAP,Y  Store the accumulator (result) back into
              the BITMAP.
```

```
TABLE—1000 0000 Remainder 0 sets 7th bit
       0100 0000 Remainder 1 sets 6th bit
       0010 0000 Remainder 2 sets 5th bit
       0001 0000 Remainder 3 sets 4th bit
       0000 1000 Remainder 4 sets 3rd bit
       0000 0100 Remainder 5 sets 2nd bit
       0000 0010 Remainder 6 sets 1st bit
       0000 0001 Remainder 7 sets 0th bit
```

Listing 3: *The code for the calculation of BYTE and REMAIN.*

```
LDA POSN      Load the accumulator with POSN.
AND #%00000111 Perform an AND on the accumulator
              with the binary value 00000111. The
              result of this operation will be zero
              out bits 7, 6, 5, 4, and 3. Bits 2, 1, and
              0 remain as they were.
STA REMAIN    Store the result in REMAIN.
LDA POSN      Load the accumulator with POSN.
LSR           Shift the accumulator to the right (LSR
              = logical shift right one bit) three
              times and ignore the bits which fall out.
              (Note that each LSR pushes a 0 into the
              high-order bit.
LSR
LSR
STA BYTE      Store the result of the shifts in BYTE.
```

THIS IS IT!

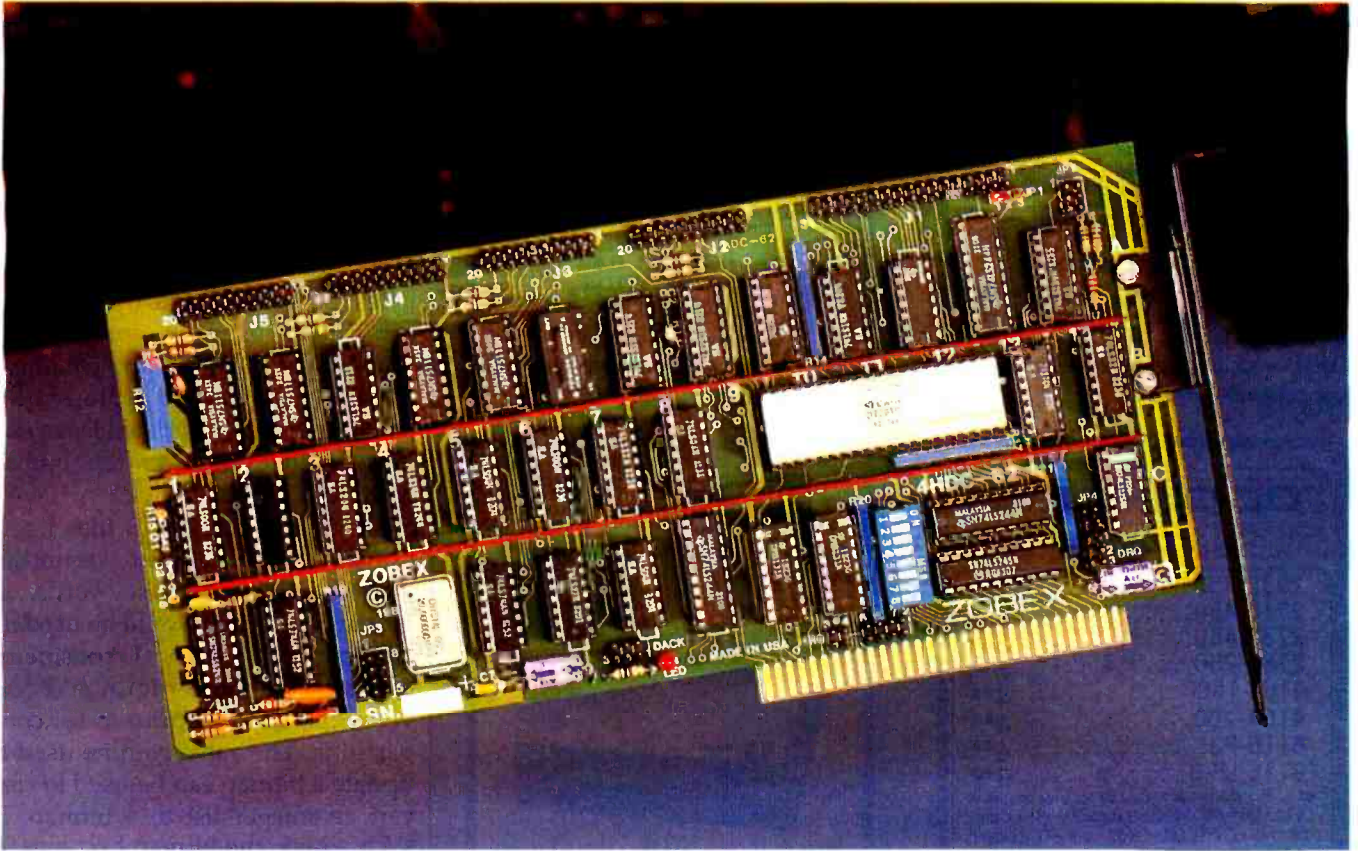

The **HARD DISK CONTROLLER** for IBM PC and TI PROFESSIONAL Computers

Whether you use MINISCRIBE, SEAGATE, SHUGART, TANDON, DISKTRON, SYQUEST, MAXTOR or others with ST506 compatible interface, this is the **ONLY BOARD** you need.

It plugs right into the IBM PC, and features:

- Parallel seek — allows overlap seeks between drives
- ECC generation/check/correction
- CRC generation/check
- Up to 4 disk drives
- Write-protect each drive individually
- CARTRIDGE CHANGED, CHANGE CARTRIDGE and CARTIDGE IN lines are provided to allow use of cartridge type disk drives
- Compatible with 140 Mbyte MAXTOR drive
- Programmable track format: data length is variable from 128 - 4095 bytes/sector
- Data transfer rate 5 Mbits/sec
- Multiple sector transfer
- Multiple track transfer
- Data scan, Data verify commands
- DMA Data transferring

Dealer's inquiries invited.

Competitive Pricing

HARD DISK SUBSYSTEM AVAILABLE

For more information contact:

ZOBEX

7343-J Ronson Road • San Diego, CA 92111 • (619) 571-6971

ZOBEX IS A TRADEMARK OF ZOBEX CORPORATION

IBM IS A TRADEMARK OF INTERNATIONAL BUSINESS MACHINES CORPORATION

TI PROFESSIONAL IS A TRADEMARK OF TEXAS INSTRUMENTS CORPORATION

Circle 521 on inquiry card

www.americanactionhistory.com

APPLEWARE, INC.
 The Apple Users Group
 Software Library Bonanza
At truly affordable prices!
 For the first time enjoy your
 Apple to its fullest capacity,
 using specially packed disks
 with over 60 outstanding
 programs each.
 (not available from any other source)

Each packed disk includes an extensive variety of
 interesting, useful and entertaining programs
 indispensable to all computerists! Each mixed category
 packed disk includes:

**BUSINESS • EDUCATIONAL • DATA BASE • GAMES
 UTILITIES • SCIENCE • MUSIC • GRAPHICS • FINANCE**
 Library Disks I, II and III are mixed categories. Dedicated
 disks are:

• **GAMES • UTILITIES • GRAPHICS • INTEGER •
 SCIENCE & TECHNOLOGY.** Each packed disk is
 available for only \$59.95 each.

WHY PAY MORE?
 Order direct from this ad and **Save up to \$150.** Buy
 Library Disks I, II and III and get a special bonus disk
FREE over 260 programs for \$179.95 + \$3
 shipping. For the best value, receive all 3 disks featuring
 over 600 of our best programs for only 65¢ each
 for a package price of only \$389. Postage Paid!

NEW Business • Professional • Executive Package (enabling
 you to bring your business to its highest level of efficiency) also
 available. Circle Readers Service Card for our complete catalog.

**For Orders Only Call now
 TOLL FREE: 1-800-327-8664**
 Florida: 1-305-987-8665

Compatible with II, II+, IIe, III Emul., and Franklin Ace (For 3 3 DOS)

Circle 42 on inquiry card.

PC PIPELINE
 Low, direct prices • Fast, direct service

2532-450.....	\$ 4. ²⁵
2716-450.....	3. ²⁰
2732-450.....	3. ⁹⁹
2764-250.....	7. ¹⁵
4164-150P.....	4. ⁷⁹
4164-200.....	4. ⁵⁰
6116-P3.....	4. ³⁰
6116-LP-3.....	4. ⁵⁰

Add \$2.95 shipping to all orders. 2.6% for credit card orders
 OEM • Quantity discounts available • P.O.s on
 approval • C.O.D. OK • Credit cards • FL residents
 add 5% tax • All new, no surplus, no seconds
 (Prices subject to change.)

4920 Cypress St., Suite 100, Tampa, FL 33607
 In FL, and for info., call 813-875-0299
FOR ORDERS ONLY, 800-237-8910
 8AM-5PM EDT

MasterCard VISA

Circle 182 on inquiry card.

DISKETTES
3M Scotch BRAND

AT SUPER LOW PRICES
 WE WILL SHIP YOUR ORDER
 WITHIN 24 HOURS AND WE PAY
 THE SHIPPING CHARGES

3M

COD ACCEPTED
 DEALER INQUIRIES INVITED

CALL TOLL FREE
800 922-8193

IN CALIFORNIA
800 468-1068

Tayco Business Forms
 Computer Supplies
 Post Office Box 605
 Newbury Park, CA 91320

Circle 460 on inquiry card.

ANALOG ↔ DIGITAL
DIGITAL ↔ ANALOG
CONVERSION MODULES
SOFTWARE
GAIN CONTROL

high accuracy — programmable gain instrumentation
 amplifier — custom board test — 100 — 2 to 15 kHz
 conversion time — mixable high and low inputs — gain
 from 1 to 1024 — 12 bit — sample and hold amplifier
 8-channel differential — 16-channel — analog to digital
 high accuracy — programmable gain instrumentation
 amplifier — custom board test — \$100 — 2 to 15 kHz
 conversion time — mixable high and low inputs — gain
 from 1 to 1024 — 12-bit — sample and hold amplifier
 8-channel differential — 16-channel — analog to digital
 high accuracy — programmable gain instrumentation
 amplifier — custom board test — \$100 — 2 to 15 kHz

For additional details about the AD-100-4 and other
 fine California Data Corporation 100% individually
 tested, high reliability products, circle the reader
 service card number below or for faster response
 write or call us.

**CALIFORNIA DATA
 CORPORATION**
 3475 Old Conejo Road, Suite C-10
 Newbury Park, CA 91320
 (805) 498-3651

Circle 76 on inquiry card.

ADDS VIEWPOINT \$550.00 **INTRODUCING THE**
PRO-100
COMPUTER

ONLY
\$1995
COMPLETE

**SINGLE BOARD COMPUTER • Z80A • 64KRAM • 2 SERIAL
 PORTS • 1 CENTRONICS PORT • SYSTEM TEST PROM
 TWO 8" DISK DRIVES • CP/M COMPATIBLE • SUPER FAST
 DISK ACCESS • 32K SOFTWARE SPOOLER • DIGITAL
 PHASE LOCK LOOP • WORKS IN EITHER IBM STANDARD SD
 OR DD • OEM AND PRIVATE LABELS AGREEMENTS
 ARE AVAILABLE • DEALER DISCOUNTS.**

MANUAL & SCHEMATICS \$ 35 **CYBERTEK CORP.**
BOARD KIT \$300 P.O. Box 1913
CHASSIS KIT \$300 Hialeah, FL 33011-1913
CPM + BIOS \$150 Tel. (305) 386-4750

Circle 131 on inquiry card.

APPLE IIe 80 Col./64K	VIC 20 24K mem exp.
BARE BOARDS	
29.00	
<ul style="list-style-type: none"> • Includes printed PCB • Pictorial layout • You add parts and labor 	
Assembled	129.95
Assembled	109.95
Gemini 10X printer	315.95
Parallel card w/cable	69.95
Z80 Plus	129.95
<p>"THE OPERATOR" 300 band modem doesn't require serial card. Software and full documentation included. Interfaces with most communications software including AE PRO. Auto answer w/disconnect.</p>	
149.95	<p>DATA-AITE Corporation 3086 Wheeling St. Aurora, CO 80011 (303) 366-5267</p>

Circle 138 on inquiry card.

the number of 1s in the list is almost equal to the number of 0s. If there are 100 bits set to 1 and 156 bits set to 0, a bitmap of 32 bytes can be used to represent a list containing 100 integers. As the number of 1s in the bitmap declines toward 0, however, the efficiency of the bitmap for memory use declines proportionately. This is the sparse matrix problem that occurs when a matrix is filled with a great many more 0s than 1s.

Suppose a bitmap of length 256 is used to represent the ordered list (1, 254). The bitmap still requires 32 bytes. Because a single byte of memory can be used to represent any number from 0 to 255, you could use 2 bytes of memory to represent the two integers in the ordered list, a savings of 30 bytes over the bitmap method.

In designing LITMAS files I confronted a similar problem. I estimated that of 512 possible keywords, an average of 10 to 20 would be used for any particular item. I considered using lists in integer form and converting to bitmaps prior to list comparisons. The same routine used to update a bitmap can be used to convert an integer list to a bitmap. In such a case, the bitmap becomes an intermediate form of representation that still permits rapid manipulation of lists.

In the design of LITMAS, however, I took another approach and developed a series of algorithms for the compression and expansion of bitmaps. A visual image of the files is that of an accordion. When the bellows is completely expanded, the files are ready for AND and OR operations. However, the bellows are stored on disk in a compressed format that guarantees that no bytes are 0 unless the entire bitmap is 0. In this last case, only a single byte is required.

Bitmap Compression

The manner in which compression is accomplished is best illustrated with an example and a series of diagrams. Then I will explain the coding tricks used to accomplish the compression.

THE NEW CANON MICROCOMPUTER.

Its graphic system makes brilliant
color more affordable.



Now everyone can have the advantage of a full-color graphics system at a very affordable price.

The Canon AS-100 microcomputer gives you a choice of 27 high resolution colors. Plus, its quiet color ink jet printer generates clean, crisp, impressive copies.

And it isn't just the AS-100's vivid color that dazzles. It has a powerful, fast 16-bit microprocessor with standard 128K RAM.

A choice of storage capacity that includes 5¼-inch mini or 8-inch floppy disks, with hard disk drive also available.

Operating systems CP/M-86* or MS-DOS† that accept a wide range of software programs, including WordStar** (word processing), CalcStar** (spreadsheet) and InfoStar** (data base management).

Even a choice of color or monochrome green display unit.

All of which make it the perfect tool for business and professional needs.

The new Canon AS-100. It's so smart, it makes life simple.

*CP/M-86 is a trademark of Digital Research. †MS-DOS is a trademark of Microsoft. **WordStar, CalcStar and InfoStar are trademarks of MicroPro.

B10/83

Canon U.S.A., Inc.
Systems Division
One Canon Plaza, Lake Success, NY 11042

Please send me more information about the Canon AS-100 Microcomputer.

Name _____ (Please print)

Title _____

Company _____

Address _____

City _____ (State) (Zip)

Phone () _____

Canon
So smart, it makes life simple.

THE HAND-HELD COMPUTER WITH POWERFUL CONNECTIONS.

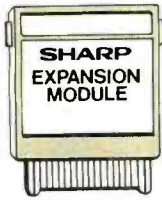

24K
(8K + 16K)

Now you can take 24K with you wherever you go—thanks to the new Sharp PC-1500A. It's the 8K hand-held computer that expands to a powerful portable 24K computer system when the optional 16K memory module is added. And because it's programmable in Basic, the most popular computer language, it gives you the power and capabilities to handle most scientific, engineering and management uses.

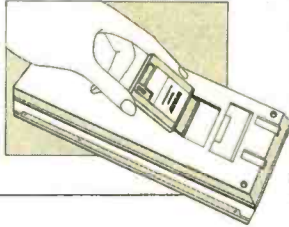

The PC-1500A also has a complete library of plug-in software programs including: Sharpcalc (Spreadsheet), Finance, Math, Electrical Engineering, Circuit Analysis, Business Graphics, General Statistics, Statistical Distribution and Graphics Development.



195(W) x 25.5(H) x 86(D) mm

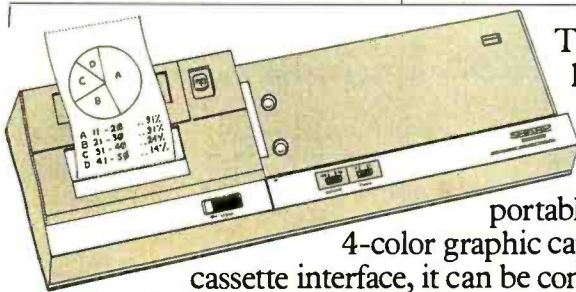
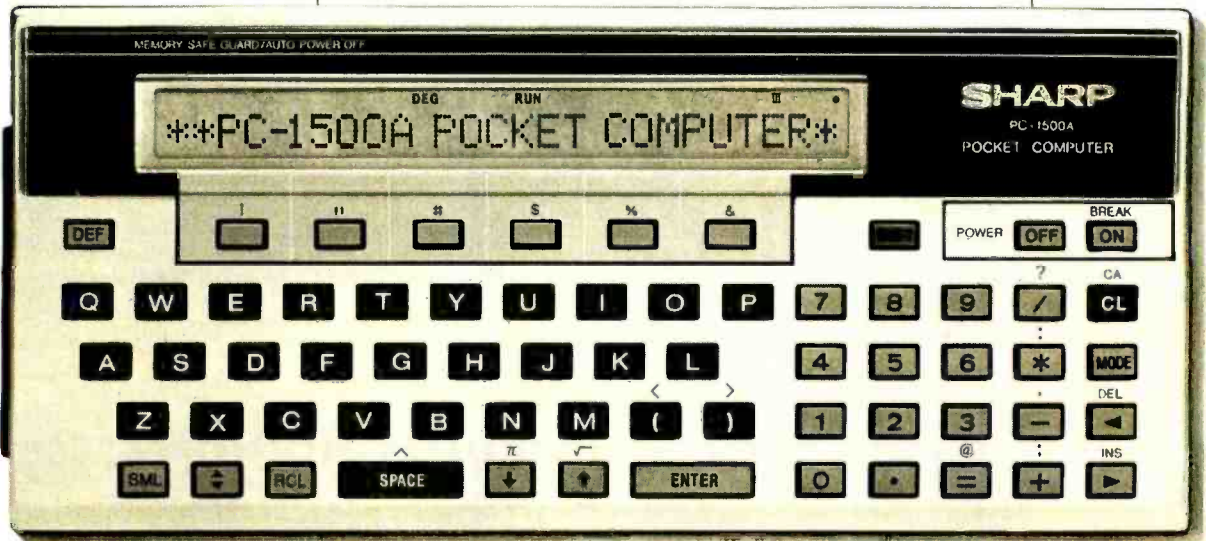

The optional CE-150 Color Graphic Printer/Cassette Interface not only gives the system portable printing but also 4-color graphic capabilities. And as a cassette interface, it can be connected with up to two cassette tape recorders—one for storage and one for recall. The CE-158's RS-232C Interface allows communication links to a wide variety of peripherals such as modems, bar-code readers, data bases, as well as other micro, mini or mainframe computers.

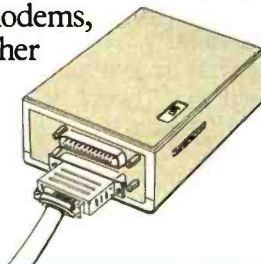

\$ Perhaps the only feature of our portable computer system that won't overpower you is its price. It's not only less than you'd expect, it's probably hundreds of dollars less. So before you spend a lot of money and get a lot less computer, call toll-free for more information, dial (800)-447-4700.



Watch for our TV commercial to learn more about the latest advance in computer technology from Sharp. We replaced a half-million transistors and diodes with one tiny "chip."

SHARP

FROM SHARP MINDS
COME SHARP PRODUCTS

Position	0	1	2	3	...	15	16	17	...	127	128	129	...	254	255
Value	0	0	1	0	...	0	1	0	...	0	1	0	...	0	1

Table 8: Bitmap representation of the list (2, 16, 128, 255). Only 4 bits out of 256 are nonzero.

zero-order bitmap. The compression scheme has been used a single time. There is no need to stop at a first-order bitmap; the compression can continue to other levels. Thus, a second-order bitmap is a doubly compressed structure, a third-order bitmap a trebly compressed structure, and so on.

To return to our example, the first-order bitmap is merely the linear string of compression values, bit 0 representing the zeroth byte of the original map, bit 1 representing the first byte of the original, bit 2 representing the second byte, and so on. In our example, the first-order bitmap is a string of 4 bytes.

Our resulting shorthand representation of the original bitmap for the (2, 16, 128, 255) list is merely the 4-byte first-order map (the compression values) together with the four nonzero bytes (bytes 0, 2, 16, and 31) of the original map.

As a result of the compression, our 32-byte original map has been reduced to 8 bytes. Within LITMAS we do not use any termination symbol between the first-order map and the original nonzero bytes. When multiple compressions are used, it is necessary to identify the number of compressions and the length of the highest-order compression. Within LITMAS, we frequently use a second-order bitmap, which looks as follows:

SECOND-ORDER MAP + NON-ZERO MEMBERS FIRST-ORDER MAP + NONZERO MEMBERS OF ORIGINAL MAP.

The second-order map is used to expand the first-order map, which is then used to expand the zero-order map.

A Compression Algorithm

Compression may appear difficult, but machine-language instructions come to our assistance. One useful instruction is ROL (rotate 1 bit left for memory or accumulator), illustrated here:

C-7-6-5-4-3-2-1-0-C,

where C is the carry bit and the

Original Bitmap

Representation

Compression Value
=1 if byte not 0

Byte 0	0 0 1 0 0 0 0 0	1
Byte 1	0 0 0 0 0 0 0 0	0
Byte 2	1 0 0 0 0 0 0 0	1
Byte 3	0 0 0 0 0 0 0 0	0
Byte 4	0 0 0 0 0 0 0 0	0
Byte 5	0 0 0 0 0 0 0 0	0
Byte 6	0 0 0 0 0 0 0 0	0
Byte 7	0 0 0 0 0 0 0 0	0
Byte 8	0 0 0 0 0 0 0 0	0
Byte 9	0 0 0 0 0 0 0 0	0
Byte 10	0 0 0 0 0 0 0 0	0
Byte 11	0 0 0 0 0 0 0 0	0
Byte 12	0 0 0 0 0 0 0 0	0
Byte 13	0 0 0 0 0 0 0 0	0
Byte 14	0 0 0 0 0 0 0 0	0
Byte 15	0 0 0 0 0 0 0 0	0
Byte 16	1 0 0 0 0 0 0 0	1
Byte 17-23	0 0 0 0 0 0 0 0	0
Byte 24-30	0 0 0 0 0 0 0 0	0
Byte 31	0 0 0 0 0 0 0 1	1

Table 9: The original bitmap representation of the list (2, 16, 128, 255), arranged as four groups of 8 bytes each, plus the compression value for each byte.

Table 8 shows a bitmap of length 256 representing the ordered list (2, 16, 128, 255). Only 4 bits in the map are set to 1, meaning that there are 252 0s. Almost all the bytes in the 32-byte bitmap are 0 (see table 9). The exceptions are easily calculated from our previous discussion. Note that table 9 includes a compression column. Look at each byte in the 32-byte bitmap. If that byte contains any nonzero bits, we place the value 1 in the compression column. If that byte in the original bitmap contains all 0 bits, we place the value 0 in the compression column. Notice also that the bytes are broken up into groups of 8. Bytes 0 to 7 are grouped together, then 8 to 15, 16 to 23, and 24 to 31. Now, look at the compression values, written as a single row and arranged in four groups corresponding to the four groups of bytes in table 9:

1. 10100000
2. 00000000
3. 10000000
4. 00000001

To optimize the compression, retain only the nonzero bytes from the original bitmap. Note that the compression values fit neatly into 4 bytes, with every bit representing a corresponding byte in the original bitmap. All zero values in a byte of the original bitmap are represented by a single 0 bit in the compression. By using a single 0 byte for a byte of 0, there is considerable memory savings.

I elected to call the original, non-compressed bitmap a zero-order bitmap. Each bit in a zero-order bitmap stands for its corresponding integer in an ordered list. A first-order bitmap is a single compression of a

numbers 0 to 7 represent bit positions within the memory or accumulator; 0 is the low-order bit and 7 is the high-order one. Note that the contents of the carry are shifted into the low-order bit while each bit shifts left

one position. The high-order bit drops out into the carry.

It is possible to set or clear the carry bit and load the result into the low-order position. Following the instruction, it is possible to test the carry bit

and determine the contents of the high-order position prior to the ROL, i.e., the previous high-order bit lands in the carry bit at the completion of the instruction.

Because the carry bit is easily tested following the ROL operation, the ROL is very useful for counting to 8. To do so, first load a memory location, M, with 1 and set the carry initially to 0. Then, perform eight consecutive ROL operations. After the eighth ROL operation, the carry goes to 1, a condition that is immediately testable in a two-cycle operation.

Listing 4 is the 6502 assembly-language algorithm for accomplishing a compression of a 32-byte bitmap. The original bitmap begins at location BITMAP, and the first-order compression bitmap is to be calculated and stored beginning at memory location FIRST. The memory location ROLBYT is used as a counter to 8 and also as the value to be placed in the first-order compression. The X index register is used as a counter for indexed addressing of BITMAP, and the Y index register is used as a counter for indexed addressing of FIRST.

Bitmap Expansion

In order to expand a compressed bitmap, you need to know both the order of the compression (number of compressions) and the length of the highest-order expression. In the previous section we were left with a compression of 4 bytes to which the nonzero members of the original bitmap are appended, as follows: FIRST-ORDER COMPRESSION + NON-ZERO BYTES FROM ORIGINAL BITMAP.

This expression is stored beginning at location FIRST. The length of the total expression is relatively unimportant. The critical pieces of information are the length of the COMPRESSION as well as the ORDER of the compression. We restrict ourselves to the case of FIRST-ORDER compressions. The length of the compression is stored in a location, LENGTH. The reconstruction of the original map is stored in contiguous memory locations beginning at BITMAP.

We use three counters:

Listing 4: The 6502 assembly-language code for compressing a 32-byte bitmap.

	LDX #0	Initialize X and Y to 0.
	LDY #0	
	LDA #1	Load accumulator with number 1.
	STA ROLBYT	Store accumulator (1) in ROLBYT.
LOOP	CLC	Clear carry. Set carry = 0.
	LDA BITMAP,X	Load accumulator with location BITMAP modified by X.
	BEQ LOOP1	If the original bitmap byte equals 0, branch immediately to ROL instruction.
	SEC	Set carry. Set carry = 1. We arrive at this instruction if BITMAPX is not 0. In this case we wish to put a 1 in the carry bit prior to executing the ROL.
LOOP1	ROL ROLBYT	The carry bit is placed in the low-order position of ROLBYT while other positions in ROLBYT are shifted left. The previous high-order position of ROLBYT falls into carry for testing.
	BCC BUMPX	Branch on carry clear to BUMPX. If the carry bit is 0, the count is less than 8. If carry is set, the count is equal to 8 and it is time to store ROLBYT in FIRST.
	LDA ROLBYT	Load accumulator with ROLBYT.
	STA FIRST,Y	Store accumulator (ROLBYT) in FIRST modified by Y register value.
	INY	Increment Y register. Y = Y + 1. In order to point to the next position in FIRST.
	LDA #1	Load accumulator with 1 and reinitialize ROLBYT.
	STA ROLBYT	
BUMPX	INX	Increment X register. X = X + 1. To point to next value in BITMAP.
	CPX #32	Compare X to 32. If X equals 32 then positions BITMAP + 0 to BITMAP + 31 have been completely processed.
	BNE LOOP	If X is unequal to #32 then continue looping. If X = 32 then fall out of the loop. The next routine is more difficult. You must guarantee that the last value in the first order map is left adjusted. Eight shifts of ROLBYT are required in order to maintain the correct order within the first-order map.
	LDA ROLBYT	Load accumulator with ROLBYT.
	CMP #1	Compare accumulator (ROLBYT) with 1. If ROLBYT equals 1 then Y has just been incremented and the original bitmap was a multiple of 8 and you are done.
	BEQ DOREST	If accumulator (ROLBYT) was equal to 1, then you are done with compression. You are ready to read the original bitmap and pick up the nonzero members. If ROLBYT was not equal to 1, then ROLBYT must be shifted to the left as many times as necessary until the carry is equal to 1.

Listing 4 continued on page 494

It's True — We Did It!

We have met or have beaten most advertised prices.

Don't be foolish. Buy Direct!



EAGLE

OUR PC FLYS

IBM Compatible
Simply a better PC. All models
available for immediate delivery
Call Lowest \$



Mannesmann Tally

- Standard — 7 x 9 160 CPS
- NLO — 40 x 18 40 CPS
- 2K Buffer and Tractor Standard

160 L 80 col. Call **Best Seller**
180 L 132 col. Call **Best Seller**

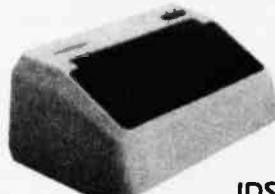

IDS

- Proportional Spacing
- 8 Character Styles
- 200 CPS Bi Directional
- Color Optional
- Sheet Feed • Graphics
- 3.4K Buffer

Prism 80
Prism 132 and Micro Prism \$ Call



Red Hot Special!

Novation J-CAT

- 300 BPS Modem
- Originate/Auto Answer

Sizzling \$84⁹⁵



Interested in opening a
Liberty Computer Catalog/Retail Store in your area?
Call 602-949-8223 for more information!

- | | | | | | |
|-----------|----------|-----------|---------------|-------------|-------------|
| ALTOS | FRANKLIN | OMNITEC | TAXAN | OKIDATA | GTC |
| ZENITH | HAYES | VENTEL | DIABLO | OSBORNE | ADDS |
| TELEVIDEO | NOVATION | AMDEK | NEC | COMREX | DEC |
| SANYO | VDS | BMC | EPSON | DAISYWRITER | C. ITOH |
| USI | EAGLE | MICOM | U.S. ROBOTICS | JUKI | SILVER-REED |
| TRANSTAR | RITEMAN | DATASOUTH | PRINTEK | STAR | MANY OTHERS |

For Price Quotes and Ordering Call:

1-800-328-8905

For Technical Information and
Arizona Orders, Call:
602-949-8218

For Shipping and Order Status Information,
Call: 602-990-7556

LIBERTY
GROUP, INCORPORATED

4221 Winfield Scott Plaza · Scottsdale, Az 85251



**Everything in
computer related
products:**

- Computers
- Modems
- Printers
- Software
- Monitors
- Terminals
- Accessories
- Paper
- Ribbons
- Diskettes
- Office Furniture

Prices listed reflect a cash discount and are subject to change without notice. We welcome Certified and Cashiers Checks, Bank Wires and Money Orders. C.O.D.s are shipped with a minimum C.O.D. charge. Allow 3-7 days for personal checks to clear. Product is subject to availability. Equipment is in factory sealed boxes with manufacturer's warranty. There will be a re-stocking charge for returned merchandise. Call first for an RMA number. Software not warranted for suitability. No return of Software which has been opened. Add 2% for shipping & handling charges (minimum \$2.50). All equipment shipped F.O.B. Scottsdale, Az 85251.

Circle 269 on inquiry card.

Listing 4 continued:

```

CLC          Clear carry. Prepare to zero out the
              low-order bits of ROLBYT.
LAST  ROL    Accumulator contains ROLBYT. ROL
              the accumulator.
          BCC LAST Branch on carry clear (carry = 0) to
              LAST. Loop continues until carry is set.
          STA FIRST,Y Now store the left adjusted accumulator
              in FIRST modified by Y register.
          INY    Increment the Y register to point 1
              location past the end of the first-order
              map.
DOREST LDX #0 When DOREST is reached, the first-
              order map has been constructed and
              placed in Y consecutive locations
              beginning at FIRST. Set up X register
              to read original bitmap. Y is already
              pointing to one position past the end of
              the compression that begins at FIRST.
LOOP2  LDA BITMAP,X Read the next member of original
              bitmap.
          BEQ BUMPXX If the byte from the original is 0, it is
              ignored. If not equal to 0, it is added to
              the end of FIRST.
          STA FIRST,Y Store the nonzero byte in next location
              in FIRST.
          INY    Increment Y to point to the next byte in
              FIRST.
BUMPXX INX   Increment X.
          CPX #32 Compare X to 32. If X equals 32, the
              original bitmap has been completely
              read.
          BNE LOOP2 If X is less than 32, return to LOOP2
              and read the next member of the
              original bitmap.
    
```

Listing 5: The 6502 code for expansion of a first-order map.

```

LDA #0      Load accumulator with 0.
STA FCTR    Store accumulator in FCTR. The
            pointer into FIRST is set to 0.
TAY        Transfer accumulator to Y register.
            Zeroes Y register, the pointer into
            BITMAP.
LDA LENGTH Load accumulator with LENGTH. The
            nonzero members of the original bitmap
            are stored beginning at FIRST +
            LENGTH.
STA NZCTR  Store NZCTR.
    
```

Memory map at beginning of processing for the compressed expression:

```

FIRST-ORDER COMPRESSION ... NONZERO BYTES OF ORIGINAL
↑
FCTR          NZCTR = FIRST + LENGTH

CMPRES LDX FCTR Load X register with contents of FCTR.
              Setting up to read next member of the
              first-order compression.
          CPX LENGTH Compare X with value of LENGTH.
              When X = LENGTH, processing is
              complete.
          BEQ END   Branch on Equal to END.
          INC FCTR  Increment FCTR. FCTR = FCTR + 1.
              To set up counter for next pass through
              CMPRES loop.
          LDA FIRST,X Load accumulator with FIRST modified
              by X register. Gets next byte from
              FIRST.
          STA TEMP   Store accumulator in TEMP. TEMP is a
              location that will be used to process the
              compression.
          LDA #1     Load accumulator with 1.
          STA ROLBYT Store accumulator (1) in ROLBYT.
              ROLBYT will be used to count to 8.
LOOP  LDA #0       Load accumulator with 0. To be used
              for insertion into bitmap in case where
              compression bit is equal to 0.
          ROL TEMP  Rotate Left TEMP. Pushes high-order bit
              into carry for testing.
          BCC STORE Branch on carry clear to store. If carry
              = 0 then 0 (in accumulator) should be
              placed in BITMAP. If carry = 1 then
              we read the next nonzero byte from the
              original bitmap.
          LDX NZCTR Load X with NZCTR. Set up X register
              with current pointer for nonzero
              members of original bitmap.
          INC NZCTR Increment NZCTR. Set up NZCTR for
              next iteration.
          LDA FIRST,X Load accumulator with contents of
              FIRST modified by X.
STORE STA BITMAP,Y Store accumulator in location BITMAP
              modified by Y register.
          INY    Increment Y to set up for next STORE.
              Process the counter ROLBYT.
          ROL ROLBYT Rotate counter ROLBYT.
          BCC LOOP Branch on carry clear to LOOP. Carry
              will be clear until eighth iteration.
          BCS CMPRES Branch on carry set to CMPRES. After
              the eighth iteration, must set up next
              byte of compression and reset ROLBYT.
              Arrive here when FCTR equals
              LENGTH.
          END    ...
    
```

1. FCTR is the counter into the FIRST-ORDER COMPRESSION.
2. NZCTR is the counter into the NONZERO BYTES.
3. Y register is a counter into BITMAP.

Because the 6502 has only two index registers, we have to use our counter locations to set the index registers.

We have elected to use the X register for the FIRST-ORDER COMPRESSION and for the NONZERO

BYTES of the original map. Listing 5 provides the 6502 code for expansion of a first-order map.

Summary

Bitmaps are an efficient data representation for performing set operations on ordered lists. The binary nature of the file allows the programmer direct use of the AND and OR functions. In some cases, bitmaps may also represent an optimal notation for an ordered list.

As the sparseness (number of 0s compared to 1s) of the bitmap increases, the efficiency of the bitmap for data encoding is compromised. Our compression technique may solve this problem for some applications. ■

Eric Sohr, MD, is chairman of the Department of Family Practice at Saint Vincent Hospital, Billings, Montana. He received his MD at the University of Maryland in 1969 and has spent the last four years designing the LITMAS system. He can be reached in care of LITMAS, Worden, MT 59088.

PRO-MODEM 1200



It's about time.

Time for your computer to make the telephone connection – with an intelligent, full 212A 300/1200 baud modem – with a real time clock/calendar – and with the capability to expand into a complete telecommunications system. It's time for PRO-MODEM 1200. Much more than just a phone modem.

When you're on-line, time is money. PRO-MODEM telecommunication systems help you save. By monitoring the duration and cost of your phone calls. And by sending and receiving messages, unattended, at preset times when the rates are lower. . . with or without your computer.

Compare the \$495 PRO-MODEM 1200 with any other modem on the market. For example, you'd have to buy both the Hayes Smartmodem 1200 plus their Chronograph for about \$950 to get a modem with time base.

PRO-MODEM 1200 is easy to use. A convenient "Help" command displays the Menu of operating command choices for quick reference whenever there's a question about what to do next. Extensive internal and remote self-diagnostics assure that the system is operating properly. Some of the other standard features include Auto Answer, Touch Tone and Pulse Dialing, and Programmable Intelligent Dialing.

PRO-MODEM does more. It lets you build a full telecommunications system with features like Auto Dialer, Incoming and Outgoing Message Buffering, Business/Personal Phone Directory, Programmable Operating Instructions, a 12-Character Alpha-Numeric Time and Message Display, and versatile PRO-COM Software. PRO-MODEM commands are Hayes compatible so you can use most existing telecommunications software without modification.

There's much more to the PRO-MODEM story. See your local dealer for complete details. He'll show you how to save time. And money.

Prometheus Products, Inc., 45277 Fremont Blvd., Fremont CA 94538, (415) 490-2370

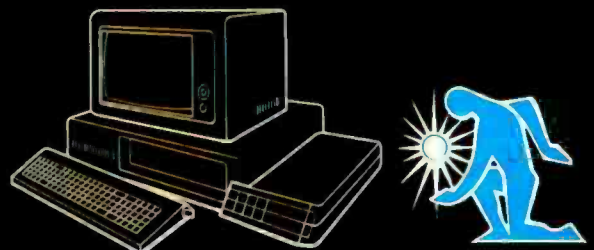

PROMETHEUS

COMPUTER MAIL ORDER

TeleVideo

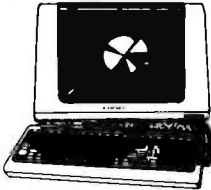

TERMINALS	
910	\$559.00
912	\$689.00
920	\$739.00
925	\$719.00
950	\$929.00
970	CALL

COMPUTERS	
800A	\$1099.00
802	\$2699.00
803	\$1949.00
802H	\$4695.00
806/20	\$4999.00
816/40	\$9199.00
1602	\$3399.00
1603	CALL

MODEMS HAYES	
Smart	\$219.00
Smart 1200 (1200 Baud)	\$519.00
Chronograph	\$199.00
Micromodem 100	\$309.00
Micromodem II	\$279.00
Micromodem II (with term)	\$299.00
Smart Com II	\$99.00
Smart 1200B	\$469.00

NOVATION	
J-Cat	\$119.00
Cat	\$144.00
D-Cat	\$159.00
103 Smart Cat	\$189.00
Apple Cat II	\$279.00
103/212 Smart Cat	\$439.00
212 Apple Cat II	\$609.00
Apple Cat II 212 Upgrade	\$309.00

ANCHOR	
Mark I (RS-232)	\$79.00
Mark II (Atari)	\$79.00
Mark III (T. J. 99)	\$109.00
Mark IV (CBM-PET)	\$125.00
Mark V (Osborne)	\$95.00
Mark VI (IBM-PC)	\$179.00
Mark VII (Auto Ans/Auto Dial)	\$119.00
Mark VIII	\$269.00
TRS-80 Color Computer	\$99.00
9 Volt Power Supply	\$9.00

ZENITH	
ZT1 Terminal	\$369.00



HEWLETT PACKARD



HP41CV...	\$209.00
HP 75	\$749.00
HP 41C	\$146.00
HP 10C	\$52.00
HP 11C	\$69.00
HP 12C	\$92.00
HP 15C	\$92.00
HP 16C	\$92.00

For HP41/41CV	
HPIL Module	\$99.00
HFIL Cassette or Printer	\$359.00
Card Reader	\$144.00
Extended Functions Module	\$64.00
Time Module	\$64.00

EAGLE



IIE-1	\$1369.00
IIE-2	\$1649.00
IIE-3	\$2399.00
IIE-4	\$3199.00
PC-E	\$1579.00
PC-1	\$2399.00
PC-2	\$2799.00
PC-XL	\$3599.00
1620	\$3599.00
1630	\$5499.00
1640	\$6499.00
Cyma Software	CALL

MONITORS

AMDEK	
300G	\$149.00
300A	\$159.00
310A	\$169.00
Color I	\$279.00
Color I plus	\$299.00
Color II	\$399.00
Color III	\$349.00
Color IV	\$999.00

UBI	
Pi 1. 9" G	\$99.00
Pi 2. 12" G	\$119.00
Pi 3. 12" A	\$159.00
Pi 4. 9" A	\$139.00
1400 Color	\$299.00

ZENITH	
ZVM 122A	\$119.00
ZVM 123G	\$109.00

BMC	
12" Green	\$85.00
9191 13" Color	\$299.00

TAXAN	
12 N Green	\$129.00
12 A Amber	\$139.00

PANASONIC	
TR 120 Hi-res. Green	\$149.00
CT 160 Dual Mode Color	\$279.00

NEC	
JB 1260	\$119.00
JB 1201	\$149.00
JC 1212	\$299.00
JC 12-202	\$299.00
JC 1203	\$469.00

GORILLA	
12" Green	\$89.00

EPSON COMPUTERS

QX-10	CALL
HX-20	CALL

TI-40 COMPACT COMPUTER

\$209

TIMEX SINCLAIR \$49 ⁹⁵ 1000	
16K Memory	\$44.95
2040 Printer	\$99.95
Vu-Calc	\$17.95
Mindware Printer	\$99.00

IBM



NEC 3550 PRINTER... \$1799

PERCOM/TANDON DRIVE	
5 1/4" 320K Floppy	\$279.00
5 meg hard w/controller	\$1495.00
10 meg hard w/controller	\$1795.00
15 meg hard w/controller	\$2195.00
20 meg hard w/controller	\$2595.00

ABT RESEARCH, INC	
SIXPAK PLUS. 64K	
clock, serial, parallel	\$299.00
clock, serial, parallel, gameport	\$339.00
MEGAPLUAI. 64K	
clock, serial, parallel	\$339.00
clock, serial, parallel, gameport	\$419.00
COMBO PLUS II. 64K	
clock, serial, parallel	\$299.00
I/OPLUS II	
clock, serial, parallel	\$145.00
clock, serial, parallel, gameport	\$179.00

PROFESSIONAL SOFTWARE	
PC Plus Word Processing	\$319.00

MICRO PRO	
Word Star/Mail Merge	\$319.00
InfoStar	\$299.00
Spell Star	\$159.00
CallStar	\$159.00

MICROSTUP	
Crosstalk	\$139.00

MICROSOFT	
Multiplan	\$199.00

ASHTON-TATE	
D-Base II	\$419.00

IUB	
EasyWriter II	\$209.00
EasySpeller	\$129.00
EasyFiler	\$129.00

CONTINENTAL SOFTWARE	
1st Class Mail/Form Letter	\$89.00
The Home Accountant Plus	\$109.00

SYNAPSE	
File Manager	\$119.00

LOTUS	
123	\$369.00

PFS	
APPLE	IBM
File	\$89.00 \$99.00
Report	\$89.00 \$89.00
Graph	\$89.00 \$99.00
Write	n/a \$99.00

KRAFT	
IBM Joystick	\$55.00
IBM Paddles	\$39.00

QUAD RAM	CALL
----------	------



PC-1500A	\$169.00
PC-1250A	\$89.00
125 Printer/Micro Cassette	\$129.00
150 Printer/Plotter/Cassette	\$172.00
152 Cassette Recorder	\$62.00
155 8K RAM	\$94.00
158 8K RAM Battery	\$129.00
161 16K RAM	\$139.00

SANYO



MBC-555PC	\$795.00
MBC 1100	\$1599.00
MBC 1150	\$2099.00
MBC 1200	\$1999.00
MBC 1250	\$2399.00
FDD 3200-320K Drive	\$399.00
FDD 6400-64K Drive	\$499.00
PR 5500 Printer	\$699.00

PRINTERS

EPSON	
MX80 FT. MX100. RX80.	
FX80. FX100	CALL

OKI/OATA	
82. 83. 84. 92. 93	CALL

STAR	
STX 80	\$169.00
Gemini 10X	\$299.00
Gemini 15	\$479.00
Serial Board	\$75.00

SMITH CORONA	
TP-1	\$469.00
TP-2	CALL
Tractor Feed	\$119.00

C.ITOH	
Gorilla	\$209.00
Prowriter 8510P	\$379.00
Prowriter 1550P	\$689.00
Starwriter F10-40P	\$1149.00
Printmaster F10-55P	\$1569.00
Tractor Feed	\$199.00

DAISYWRITER	
2000 Letter Quality	\$1149.00
2500...NEW	CALL
Tractor Feed	\$109.00

DIABLO	
620	\$949.00
630	\$1769.00

IOS	
Call for ALL Configurations on IOS PRISM PRINTERS.	

NEC	
8023	\$399.00
8025	\$729.00
3510	\$1449.00
3530	\$1499.00
3550	\$1799.00
7710/7730	\$1999.00

BMC	
401 Letter Quality	\$699.00

BROTHER	
Comriter II Printer	\$499.00

CABLES & CONNECTIONS	
Atari to Parallel	\$29.00
Atari to Serial	\$29.00
Apple to Parallel	\$69.00
Apple to Parallel/Graphics	\$99.00
Apple to Serial	\$89.00
IBM to Parallel	\$35.00
IBM to Serial	\$29.00
Parallel to Parallel	\$29.00
Serial to Serial	\$29.00
Grappler Plus	\$129.00
PKASO	\$139.00
Atari to Modem Cable	\$29.00
CBM 64 to IEEE Board	\$79.00
Apple 80 Column Card	\$159.00
CBM Pet to Parallel	\$99.00
CBM Pet to Serial	\$89.00

PAPER SUPPLIES	
1or2" Address Labels(Tract.Feed)	\$9.95
15" Report Paper(Tract.Feed)	\$24.95
8 1/2" Blink Wht Paper(Tract.Feed)	\$19.95

= WEST =

1-800-648-3311



In NV call (702)588-5654 Order Status Number: 588-5654

Dept. 1001 P.O. Box 6689, Stateline NV 89449

No risk, no deposit on C. O. D. orders. Pre-paid orders receive free shipping within the UPS continental United States with no waiting period for certified checks or money orders. Add 3% (minimum \$5.00) shipping and handling on all C. O. D. and credit card orders. Larger shipments may require additional charges. NV and PA residents add sales tax. All items subject to availability and price change. We stock manufacturer's and third party software for most all computers on the market. Call today for our catalog.

COMPUTER MAIL ORDER

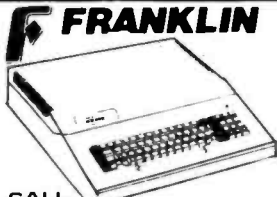

FRANKLIN
CALL
ACE 1000 Color Computer
ACE 1100 Drive & Cover for ACE 1000
ACE 1200 Computer with Disk Drive
ACE PRO PACK

ACE 1000, Disk Drive,
80 Column Card, ACECalc &
ACEWriter II
MICRO-SCI
Apple & Franklin

A2 \$249.00
A40 \$349.00
A70 \$459.00
C2 Controller \$79.00
C47 Controller \$89.00

RANA
Elite I (Apple/Franklin) \$279.00
Elite II (Apple/Franklin) CALL
Elite III (Apple/Franklin) CALL

VISICORP
FOR APPLE, IBM & FRANKLIN

Visidex \$189.00
Visifile \$189.00
Visiplot \$159.00
Visiterm \$89.00
Visitrend/Plot \$229.00
VisiSchedule \$229.00
Desktop Plan \$189.00
Visicalc (Apple, IBM, CBM) \$179.00
Visicalc 4 (IBM) \$209.00
Visicalc Advanced IIe \$309.00
Stretch Calc \$89.00
Visicorp prices for IBM may vary slightly.

LJK
Letter Perfect Apple \$109.00
Data Perfect Apple \$75.00

AXLON
Apple/Franklin 128K Ram \$299.00
Apple/Franklin Ram Disk \$729.00

MPC
Buddisk (128K Non-Volatile) \$649.00

JOYSTICKS
WICO

Joystick \$21.95
Famous Red Ball \$23.95
Power Grip \$21.95
Three-Way Deluxe \$22.95
Atari/VIC Trackball \$34.95
Apple Trackball \$59.95

KRAFT
Atari Single Fire \$13.00
Atari Switch Hitter \$16.00
Apple Joystick \$44.00
Apple Paddles \$39.00

Commodore



CBM
8032
\$ **599**

CBM64 ... \$219
VIC 20 \$99

CALL ON
Executive 64 Portable

1520 Color Printer/Plotter \$169.00
1525 80 Column Printer \$219.00
1526 \$319.00
1530 Datasette \$69.00
1541 Single Disk Drive \$249.00
1600 VIC Modem \$59.00
1650 AD/AA Modem \$89.00
1701 14" Color Monitor \$249.00
Pet 64 \$569.00
Pet 4032 \$599.00
CBM 8032 \$599.00
Super Pet \$999.00
B128-80 \$769.00
8X256-80 \$969.00
2031 \$299.00
4040 \$699.00
8050 \$949.00
8250 \$1199.00
9060 \$1999.00
9090 \$2199.00
4023 \$379.00
6400 \$1399.00
64K Upgrade \$269.00
Spell Master \$149.00
Z-Ram \$549.00
Silicon Office \$749.00
The Manager \$209.00
Soft Rom \$129.00
Jinsam CALL
Call Result 64 \$139.00

PROFESSIONAL SOFTWARE

Word Pro 2 Plus \$159.00
Word Pro 3 Plus \$189.00
Word Pro 4 Plus \$279.00
Word Pro 5 Plus \$279.00
InfoPro \$179.00
Administrator \$399.00
Power \$79.00
Word Pro 64 Plus \$65.00

CAROCD
for VIC 20/64

Light Pen \$32.00
Cassette Interface \$29.00
Parallel Printer Interface \$69.00
3Slot Expans. Interface (20) \$32.00
6Slot Expans. Interface (20) \$79.00

ATARI HOME COMPUTERS



ATARI 600XL..... \$149
ATARI 800XL..... \$269
ATARI 1200XL CALL
ATARI 400 CALL
ATARI 800 CALL

1010 Program Recorder \$74.00
1020 40 Col. Printer/Plotter \$249.00
1025 80 Col. Printer \$449.00
1027 Letter Quality Printer \$299.00
1050 Disk Drive \$379.00
1030 Direct Connect Modem CALL
CX30 Paddles \$12.00
CX40 Joystick \$8.00
CX42 Remote Joystick CALL
CX77 Touch Tablet \$69.00
CX80 Trak Ball \$49.00
CX85 Keypad \$105.00
CX418 Home Manager \$69.00
CX488 Communicator II \$229.00
KKX708 Atari Accountant \$209.00
KK7101 Entertainer \$69.00
KK7102 Arcade Champ \$75.00

ALIEN
Atari Voice Box \$119.00
Apple Voice Box \$149.00

MEMORY BOARDS
Axlion 32K Ram \$59.00
Axlion 48K Ram \$99.00
Axlion 128K Ram \$299.00
Intec 32K Board \$59.00
Intec 48K Board \$85.00
Intec 64K Board (400 only) \$99.00
Intec Real Time Clock \$39.00

DISK & CART HOLDERS
Flip-n-File 10 \$4.00
Flip-n-File 50 \$19.00
Flip-n-File 400/800 Cart \$19.00

PERCOM

DISK DRIVES FOR ATARI
AT88-S1 \$369.00
AT88-A1 \$299.00
AT88-S2 \$569.00
AT88-S1 PD \$469.00
AT88-S2 PD \$669.00
AT88-DDA \$139.00
AT44-S1 \$579.00
AT44-S2 \$969.00
TEXAS INSTRUMENTS DRIVE
TX 99-S1 \$349.00

RANA
1000 Atari Disk Drive \$319.00

FLOPPY DISKS
MAXELL
MD-1 \$32.00
MD-2 \$44.00
FD-1 (8") \$40.00
FD-2 (8" DS DD) \$50.00

ELEPHANT
5 1/4" SS SD \$18.95
5 1/4" SS DD \$24.95
5 1/4" DS DD \$29.95

VERBATUM
5 1/4" SS DD \$26.00
5 1/4" DS DD \$36.00

HEAD
Disk Head Cleaner \$14.95

C.M.O. TOP 80

APPLE/FRANKLIN

- Choplifter \$27.00
- Bank Street Writer \$55.00
- PFS: File \$89.00
- Visicalc \$179.00
- Home Accountant \$55.00
- Zaxxon \$29.00
- Most Amazing Thing \$28.00
- Visifile \$189.00
- Fathoms 40 \$19.00
- Deadline \$35.00
- PFS: Report \$89.00
- Zork III \$29.00
- Frogger \$24.00
- Facemaker \$24.00
- Snooper Troops #1 \$32.00
- Delta Drawing \$35.00
- Castle Wolfenstine \$24.00
- Wayout \$29.00
- Canyon Climber \$19.00
- Bandits \$26.00

CBM 64

- Word Pro 64 \$65.00
- Jumpman \$29.00
- Gorf (20/64) \$14.95
- Microspec Data Base 64 \$69.00
- Logo 64 \$39.00
- Microspec Gen. Ledger 64 \$79.00
- Zork III \$29.00
- Frogger (64) \$23.00
- Quick Brown Fox (20/64) \$49.00
- Shamus \$29.00
- Deadline \$29.00
- Assembler 64 \$14.95
- Zork II \$29.00
- 3-D Man \$14.00
- Protector \$32.00
- Starcross \$29.00
- Easy Mail 64 \$14.95
- Grave Robber \$11.00
- Wall Street \$19.00
- Trash Man \$32.00

ATARI

- Donkey Kong \$39.00
- Zaxxon \$29.00
- E.T. Phone Home \$39.00
- Minor 2049er \$35.00
- Dig Dug \$33.00
- Choplifter \$29.00
- Donkey Kong, Jr \$39.00
- Canyon Climber \$25.00
- Snooper Troops #2 \$34.00
- Word Wizard \$59.00
- Picnic Paranoia \$34.00
- Jumpman \$29.00
- Shamus \$34.00
- Letter Perfect \$109.00
- File Manager 800 \$69.00
- Preppie \$24.00
- Astro Chase \$25.00
- Blade/Black Hole \$27.00
- Pac Man \$33.00
- Baja Buggies \$25.00
- Crush, Crumble & Chomp \$24.00
- Wayout \$27.00
- Zork II \$29.00
- Visicalc \$159.00
- Atari Writer \$79.00
- Three Little Pigs \$25.00
- Upper Reaches of Apshai \$16.00
- Starbowl Football \$24.95
- Drelbs \$26.00
- Protector \$34.00
- PFS: Report \$25.00
- Lunar Lopper \$24.00
- Wizard of Wor \$34.00
- Kindercomp \$21.00
- Moon Shuttle \$22.00
- Home Accountant \$55.00
- Temple of Apshai \$29.00
- Spell Wizard \$39.00
- Nautitus \$26.00
- O'Riley's Mine \$22.00

= EAST =

1-800-233-8950

In PA call (717)327-9575 Order Status Number: 327-9576

Dept. 1001, 477 E. Third Street, Williamsport, PA 17701

International Orders: All shipments outside the continental United States must be pre-paid by certified check only. Include 3% (minimum \$5.00) shipping and handling. Educational Discounts: Additional discounts are available from both Computer Mail Order locations to qualified Educational Institutions. APO & FPO: Add minimum \$5.00 shipping and handling. Circle 111 on Inquiry card.

Why American Business Trusts Emery.



Lawyer

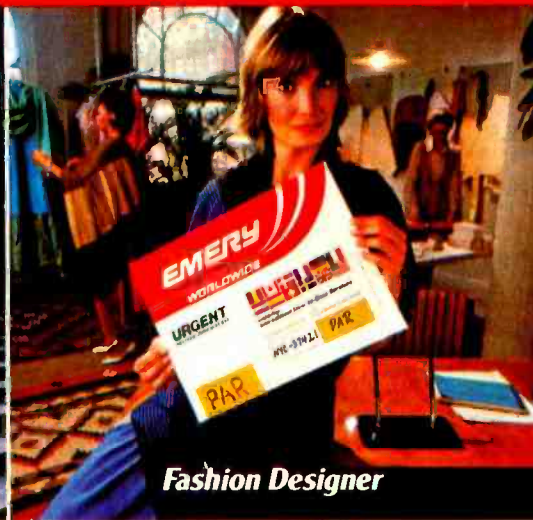

Fashion Designer



Computer Manufacturer

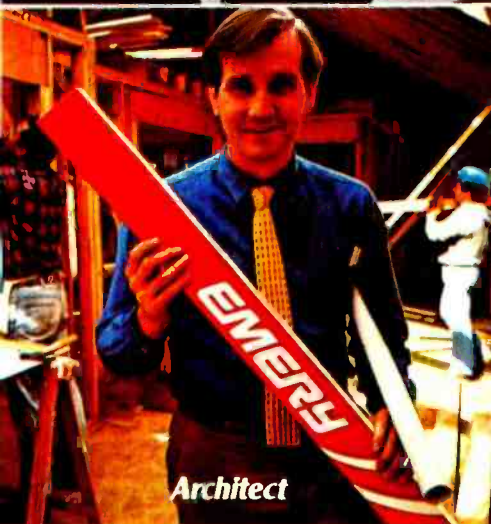

Architect



Oil Well Engineer

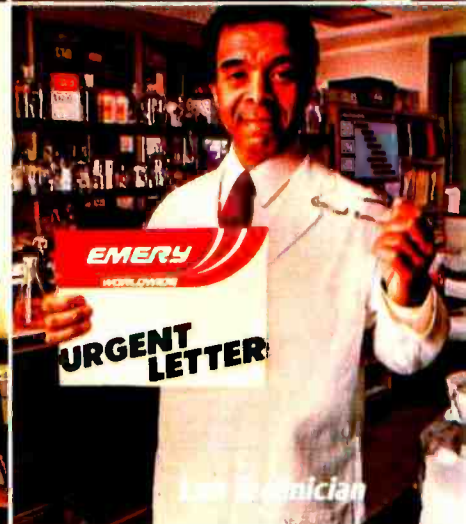

Law Medician

These people represent more than one million customers who count on Emery to deliver everything from a contract or a computer chip—all the way up to a large automotive part.

No matter what America's shipping needs are, Emery provides reliable, on-time delivery to over 96,000 communities across the country. Emery features next day service with your choice of AM or PM delivery times. When savings are more critical than time, we offer a second day service, too.

And in an emergency, one call will speed Emery Same Day Service into action—with results by the end of the same day. In addition, Emery can deliver to thousands of locations outside the United States. With Emery First Class International Service, for example, you can ship any size package to major European cities, door-to-door—within forty-eight hours. So whether you send one contract a week or over a hundred packages a day, Emery can deliver. Call your local Emery office today and find out how Emery has earned the trust of successful businesses all over America. © Emery Worldwide 1983

Circle 174 on inquiry card.



EMERY
WORLDWIDE

We've earned the trust of American Business.

Simplified Program Interfacing

By using jump and data tables, this technique overcomes the drawbacks of traditional methods of interfacing programs

by Raymond F. Irvine

You can employ a programming technique based on jump and data tables to simplify the interface between two programs when at least one of them has fixed entry points and data addresses. Most of the example programs presented here are written in BASIC and execute USER calls to assembly-language subroutines. Although these programs use Microsoft BASIC and Z80 mnemonics, you can easily adapt the technique to other languages or processors. The versions presented should suit the needs of both cassette and disk users.

The Standard Interface

The most obvious, hence most common, technique programmers use to interface a BASIC program to assembly-language subroutines is shown in listing 1. The BASIC program calls each assembly-language subroutine directly at the location at which the routine resides in memory. Typically, data is passed between programs using BASIC PEEKs and POKEs to data areas located somewhere within or following the subroutine that uses the data. This common technique produces functional

programs; however, it is cumbersome to use during the development and debugging process. Usually, any change to an assembly-language routine results in the shifting of addresses following the change. This shift, in turn, frequently affects BASIC entry points and data-transfer locations.

Listing 2 demonstrates how adding only one line of assembly-language code can force several changes to a BASIC program. This need to modify the program can be a nuisance, especially to cassette users who do not have the option of using hexadecimal notation in BASIC and must convert each address to decimal form. Because the typical process of testing and debugging a program results in several such iterations, any means of reducing the impact of assembly-language changes on the BASIC interface makes the overall task much easier for the programmer.

The standard technique is inefficient because the programmer is making direct calls to routines that are embedded within code that is subject to frequent changes. This situation is similar to the one that confronts a programmer who assem-

bles his programs by hand or who uses a simple assembler that does not recognize labels. Each time he changes some code, he must update addresses throughout his program to compensate for his changes. The use of such direct references to address locations forces the programmer to assume this time-consuming chore. On the other hand, an assembler that allows use of labels permits a programmer to concentrate on his program and to use labels that indirectly refer to memory locations; the assembler itself keeps track of the addresses. Although the technique presented here doesn't provide labels that can be recognized by both BASIC and the assembler, it does make use of a form of indirect addressing that lets the assembler do most of the work to virtually eliminate the impact of assembly-language changes on a BASIC program.

Jump and Data Tables

The BASIC/assembly-language interface can be improved by restructuring the assembly-language program with the addition of a jump table and by consolidating all address locations used to pass data between

programs into one data table. These two tables are placed prior to any of the assembly-language routines to protect their locations from being arbitrarily moved as the assembly-language routines are altered. All BASIC PEEKs, POKEs, and USER calls are then directed through these tables. Listing 3 demonstrates how to implement the tables in the assembly-language program and how they should be accessed from BASIC.

The jump table becomes the first part of the assembly-language program. This table consists of a series of jump instructions directing program flow from the entry points to the actual routines to be accessed from BASIC. When the BASIC program initiates a USER call to an assembly-language subroutine, program execution transfers to the jump table. Because the assembler automatically updates the destination addresses of these jumps, a set of entry points has been established that does not change regardless of how many times the actual locations of the subroutines are shifted.

All data locations that are to be accessed by BASIC PEEKs and POKEs should be placed immediately following the jump table. By placing these data locations before the assembly-language routines, the data table has also been protected from any changes made to the routines. If it becomes necessary to add new locations to the table, they should be placed after the existing entries in order to preserve the existing locations of the addresses.

If you want to add new routines to an assembly program, make sure you've reserved space in advance by extending the jump table with spare entries pointing to either dummy addresses or a return instruction. For instance, a jump table for a BASIC interface can be created with 10 entries, one to correspond with each of BASIC's USER0(X) through USER9(X) call instructions.

Listing 4 shows the assembly program with jump and data tables after one line of code was added to a routine. While all addresses after the new line were changed, the BASIC interface through the jump and data

tables remains the same.

We have now defined a structure for assembly programs that virtually eliminates the need to change BASIC USER calls, PEEKs, or POKEs in order to accommodate modifications made to assembly-language routines. This technique also makes it easier to define the BASIC/assembly-language interface in advance, producing the additional benefit of reducing the effort required before concurrent development of BASIC and assembly-language programs can begin.

More USER Calls

Jump tables are most effective when the BASIC interpreter is capable of making multiple USER calls. Most cassette BASICs provide only one USER call, and in some cases even the 10 USER calls of disk BASIC are not sufficient. Listing 5 presents a method of using a data location as an index to expand the number of USER calls available from BASIC to 255, when a 1-byte index is used.

To use the CLCINX routine (see listing 5), define the first entry point (ENTRY0) as the index routine and define the first (or only) USER call at this entry point. Then POKE the index location (INDEX) with the number of the desired routine (1 to 255). This number is determined by its order in the jump table, with the first jump (to CLCINX) being number zero. When the USER call is executed, the CLCINX routine calculates the proper entry point into the table and transfers execution to that address.

The CLCINX routine works by taking the number stored in INDEX and using it to form an offset to determine the appropriate jump-table entry point. This routine first checks that the index number is not zero. If zero were allowed, an endless loop would occur because the routine would repeatedly access itself. After this test, the number is tripled because each jump instruction is 3 bytes long. This result is then added to the address of the first jump instruction (ENTRY0) so that the HL register pair holds the address of the desired jump-table entry. Program control is then transferred to this address.

Assembly/Assembly Interfacing

The examples and descriptions presented so far in this article have dealt with the technique of interfacing BASIC programs to assembly-language subroutines; however, jump tables are also very useful when you're interfacing two or more assembly-language programs. One of the most common examples of this is in the implementation of the BIOS (basic input/output system) for Digital Research's CP/M.

The CP/M BIOS contains all the code required to configure the system to a specific hardware environment. By using a jump table (listing 6) to provide the interface with the standardized portion of the CP/M system, Digital Research significantly reduced the amount of effort otherwise required to implement CP/M on a specific system. This certainly has helped in establishing CP/M as a de facto standard for 8-bit microprocessor operating systems.

Another common use of jump tables is in monitor or bootstrap programs. Usually, the first entry point is accessed by a power-on jump or another absolute jump rather than a subroutine call. This allows the program to operate on a stand-alone basis. Routines within the program, such as console I/O, primitive disk I/O, or tape I/O, are made available as subroutines to other programs through the jump table.

Summary

The techniques presented in this article are relatively easy to apply and will relieve much of the frustration and busywork typically required when interfacing between two or more programs. The examples are simple and general enough for adaptation in most situations; however, you sacrifice a small amount of memory (30 bytes for a 10-entry jump table) and a few microseconds of additional time to execute the jump instruction. ■

Raymond F. Irvine (646 Pearson Rd., Port Hueneme, CA 93041) works at the Vitro Laboratories Division of Automation Industries. He has studied at California State Polytechnic University at Pomona and California State University at Fullerton.

HARD COPY MADE EASY.

**New KODAK
INSTAGRAPHIC™
CRT Imaging Outfit
makes it simple
and economical to
picture computer
or video displays
in full photographic color.**



For ONLY
\$190

*List Price

TO ORDER,
CALL NOW TOLL-FREE:
1-800-328-5618.

MINNESOTA RESIDENTS, CALL:
1-800-322-0493.

Or use this coupon
and order by mail.

Now there's an easy, economical way to record CRT data and communicate complex ideas... with full-color instant prints, conventional photos, or slides.

Simply mount the Kodak Instagraphic camera on its cone, hold over a 12- or 13-inch CRT screen, and press the button. That's it! Get a photographic record—an instant print or 35 mm slide—of cathode-ray-tube charts, graphics, etc., for reports, documentation, or group presentations. Without darkening the room. Without ambient light and parallax concerns. Without focusing. Without tying up your terminal, color printer, or plotter.

The imaging outfit includes everything you'll need to get started for just \$190. Get an Instagraphic camera with close-up lens; two packages of new Kodak Instagraphic color print film; a Kodak Instagraphic CRT cone, model 12; an instruction manual; plus filter, carrying strap, foam strips, bumpers, spacers, and brackets for adapting a 35 mm single-lens-reflex camera to the cone.

Motion Picture and Audiovisual Markets Division
Eastman Kodak Company, Rochester, NY 14650



(Note: Also available through your local dealer in Kodak audiovisual, professional, and x-ray products.)

KODAK INSTAGRAPHIC CRT Imaging Outfit Offer
P.O. Box 82627, St. Paul, MN 55182-9990

YES, I WANT TO MAKE HARD COPY EASY.

Please rush me _____ KODAK INSTAGRAPHIC CRT Imaging Outfits at \$190 each Amount \$ _____
Shipping and handling \$ 7.95
Applicable state and local sales taxes \$ _____
Total \$ _____

- My check or money order payable to Eastman Kodak Company is enclosed.
 Please charge my credit card: VISA MasterCard American Express

Account No. _____

Expiration Date _____ Interbank Number (MC only) _____

Name _____

Address _____

City _____ State _____

Zip _____ Phone _____

Signature _____

Please allow 6 weeks for delivery.

© Eastman Kodak Company, 1983

* Price shown is Kodak's current list price and is subject to change without notice. Dealer prices may vary.

Listing 1: An assembly-language routine (a) and a BASIC program (b) showing the technique most programmers use to interface two such programs. Note that BASIC USER calls are made directly to RTNO (line 140 of the assembly-language code) and RTN1 (line 340).

```
(a)
00010 ;*****
00020 ;*****
00030 ;** ASSEMBLY LANGUAGE SUBROUTINE **
00040 ;** TO BE CALLED FROM BASIC **
00050 ;*****
00060 ;*****
00070 ;
00080 ;   ORG 0F000H ;START AT F000H
00090 ;
00100 ;*****
00110 ;   ROUTINE 0
00120 ;*****
00130 ;
00140 RTNO LD A, (DATA1) ;1ST ENTRY POINT
00150 LD B, 05H ;IGNORE CODE

F000

00240 LD (DATA2),A ;SAVE ANSWER
00250 RET ;RETURN TO BASIC
00260 ;
00270 DATA DEFB 00H ;DATA FROM BASIC
00280 DATA2 DEFB 00H ;ANSWER FOR BASIC
00290 ;
00300 ;*****
00310 ;   ROUTINE 1
00320 ;*****
00330 ;
00340 RTN1 LD A, (DATA3) ;2ND ENTRY POINT
00350 SLA A ;IGNORE CODE

F03F 3244F0 LD (DATA4),A ;SAVE ANSWER
F042 C9 RET ;RETURN TO BASIC
00490 ;
F043 00 DATA3 DEFB 00H ;DATA FROM BASIC
F044 00 DATA4 DEFB 00H ;ANSWER FOR BASIC
00520 ;
0000 0000 END ;END OF ROUTINES

(b)
10 REM ASSEMBLY PROGRAM ALREADY LOADED
20 REM BASIC MEMORY SIZE SET AT 0EFFFF
30 DEFUSRO = &HF000: REM ENTRY POINT FOR ROUTINE 0
40 DEFUSR1 = &HF025: REM ENTRY POINT FOR ROUTINE 1
```

```
100 POKE &HF023,B: REM SEND DATA TO ROUTINE 0
110 A=USRO(X): REM EXECUTE ROUTINE 0
120 C=PEEK(&HF024): REM GET THE ANSWER
```

```
200 POKE &HF043,D: REM SEND DATA TO ROUTINE 1
210 A=USR1(X): REM EXECUTE ROUTINE 1
220 E=PEEK(&HF044): REM GET THE ANSWER
```

```
300 END
```

Listing 2: An assembly-language listing (a) and a BASIC program (b) illustrating the impact of the addition of one line of assembly code (line 240). The affected addresses in the BASIC program are underlined.

```
(a)
00010 ;*****
00020 ;*****
00030 ;** ASSEMBLY LANGUAGE SUBROUTINE **
00040 ;** TO BE CALLED FROM BASIC **
00050 ;*****
00060 ;*****
00070 ;
00080 ;   ORG 0F000H ;START AT F000H
00090 ;
00100 ;*****
00110 ;   ROUTINE 0
00120 ;*****
00130 ;
00140 RTNO LD A, (DATA1) ;1ST ENTRY POINT
00150 LD B, 05H ;IGNORE CODE

F000

F000 3A25F0 LD A, (DATA1) ;1ST ENTRY POINT
F003 0605 LD B, 05H ;IGNORE CODE

00240 ;*****
00250 ;*****
00260 ;*****
00270 ;*****
00280 ;*****
00290 ;*****
00300 ;*****
00310 ;*****
00320 ;*****
00330 ;*****
00340 ;*****
00350 ;*****
00360 ;*****

F01F E67F AND 7FH ;* ADD NEW CODE *
F021 3226F0 LD (DATA2),A ;SAVE ANSWER
F024 C9 RET ;RETURN TO BASIC
00270 ;
F025 00 DATA DEFB 00H ;DATA FROM BASIC
F026 00 DATA2 DEFB 00H ;ANSWER FOR BASIC
00300 ;*****
00310 ;*****
00320 ;*****
00330 ;*****
00340 ;*****
00350 ;*****
00360 ;*****

F027 3A45F0 LD A, (DATA3) ;2ND ENTRY POINT
F02A CB27 SLA A ;IGNORE CODE
```

Frustration Insurance.

The Assembly Language Programming Series from Osborne/McGraw-Hill.



1) 6502 Assembly Language Programming
Leventhal Order #27-6 \$18.95
"The book that will probably get the reputation as being the 6502 Bible."
INTERFACE AGE



2) 6502 Assembly Language Subroutines
Leventhal, Saville Order #59-4 \$17.95
Over 50 ready-to-use subroutines.



3) Assembly Language Programming for the Apple II.
Mottola Order #51-9 \$15.95
Run programs hundreds of times faster and use less memory space than with programs written in BASIC.

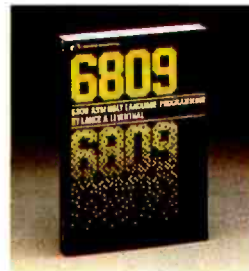

4) 6809 Assembly Language Programming
Leventhal Order #35-7 \$18.95
"Leventhal appears to have a formula for producing programming manuals. If so, it's a good formula... he has produced another clear and thorough manual for the serious programmer."
AMERICAN MATHEMATICAL MONTHLY



5) 6800 Assembly Language Programming
Leventhal Order #12-8 \$18.95
A complete reference to the 6800 instruction set and programming techniques.



6) 68000 Assembly Language Programming
Leventhal Order #62-4 \$18.95
Covers 68000 assembly language programming in the explicit detail needed to tap the full potential of this highly evolved microprocessor.



7) Z80[®] Assembly Language Programming
Leventhal Order #21-7 \$18.95
"There may never be a better book on the Z80 assembler than this one..."
CREATIVE COMPUTING



8) Z80[®] Assembly Language Subroutines
Leventhal, Saville Order #91-8 \$17.95
Over 50 useful subroutines to save you valuable programming time.

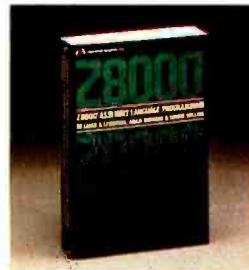

9) Z8000[®] Assembly Language Programming
Leventhal, Osborne, Collins Order #36-5 \$19.99
An excellent source reference for this powerful, 16-bit device. Filled with trouble-shooting hints and sample problems to guide the user to mastery of this "super chip."



10) 8080A/8085 Assembly Language Programming
Leventhal Order #10-1 \$18.95
"... an excellent encyclopedia of assembly language programming."
BYTE

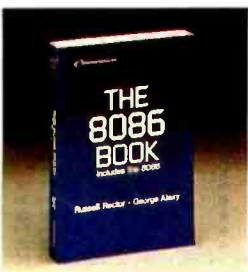

11) The 8086 Book
Rector, Alexy Order #29-2 \$16.99
"... far superior to any other book about the 8086."
DR. DOBBS JOURNAL

Before you hit the Frustration Key, reach for an Osborne/McGraw-Hill book.



By phone, call TOLL FREE: 800-227-2895. In California, call 800-772-4077. VISA and MasterCard accepted.

By Mail, complete the coupon below and mail to Osborne/McGraw-Hill, 2600 Tenth Street, Berkeley, CA 94710.

All orders must be pre-paid. Check, money order, VISA and MasterCard accepted. Add shipping fees per item: \$0.75 4th Class, \$1.50 UPS, \$3.00 1st class/UPS Blue Label. California residents, add local tax.

Allow 4-6 weeks for delivery. Prices subject to change without notice.

Z80 and Z8000 are registered trademarks of Zilog Inc.

©1983 Osborne/McGraw-Hill

Osborne/McGraw-Hill

_____ Please send me a free catalog. Dept C-1

Name _____

Address _____

City _____

State _____ Zip _____

Indicate method of payment: _____ Check/Money Order
_____ VISA/Exp. date _____ MasterCard/Exp. date _____

Card # _____

Signature _____

QTY	ORDER #	PRICE

Tax _____

Shipping _____

TOTAL _____

Osborne/McGraw-Hill
2600 Tenth Street
Berkeley, CA 94710

```

F041 3246F0 00480 LD (DATA4),A ;SAVE ANSWER
F044 C9 00490 RET ;RETURN TO BASIC
00500 ;
F045 00 00510 DATA3 DEFB 00H ;DATA FROM BASIC
F046 00 00520 DATA4 DEFB 00H ;ANSWER FOR BASIC
00530 ;
0000 00540 END ;END OF ROUTINES
(b)
10 REM ASSEMBLY PROGRAM ALREADY LOADED
20 REM BASIC MEMORY SIZE SET AT 0EFFFH
30 DEFUSR0 = &HF000: REM ENTRY POINT FOR ROUTINE 0
40 DEFUSR1 = &HF027: REM ENTRY POINT FOR ROUTINE 1
00200 ;*****
00210 ;* DATA TABLE *****
00220 ;*****
00230 ;
00240 DATA DEFB 00H ;ROUTINE 0 DATA
00250 DATA2 DEFB 00H ;ROUTINE 0 ANSWER
00260 DATA3 DEFB 00H ;ROUTINE 1 DATA
00270 DATA4 DEFB 00H ;ROUTINE 1 ANSWER
00280 ;
00290 ;*****
00300 ;* ROUTINE 0 *****
00310 ;*****
00320 ;
00330 RTN0 LD A,(DATA1) ;1ST ENTRY POINT
00340 LD B,05H ;IGNORE CODE
F013 3A0FF0
F016 0605
F032 3210F0 LD (DATA2),A ;SAVE ANSWER
F035 C9 RET ;RETURN TO BASIC
00430 ;
00440 ;
00450 ;*****
00460 ;* ROUTINE 1 *****
00470 ;* *****
00480 ;*****
00490 ;
00500 RTN1 LD A,(DATA3) ;2ND ENTRY POINT
F036 3A11F0 SLA A ;IGNORE CODE
F039 CB27
F050 3212F0 LD (DATA4),A ;SAVE ANSWER
F053 C9 RET ;RETURN TO BASIC
00650 ;
0000 00660 END ;END OF ROUTINES

```

```

100 POKE &HF025,B: REM SEND DATA TO ROUTINE 0
110 A=USR0(X): REM EXECUTE ROUTINE 0
120 C=PEEK(&HF026): REM GET THE ANSWER
.
.
.
200 POKE &HF045,D: REM SEND DATA TO ROUTINE 1
210 A=USR1(X): REM EXECUTE ROUTINE 1
220 E=PEEK(&HF046): REM GET THE ANSWER
.
.
.
300 END

```

Listing 3: An assembly-language routine (a), including jump and data tables, and a BASIC program (b), which calls the assembly-language routine via the jump and data tables.

```

(a)
00010 ;*****
00020 ;*****
00030 ;** ASSEMBLY LANGUAGE SUBROUTINE **
00040 ;** TO BE CALLED FROM BASIC **
00050 ;*****
00060 ;*****
00070 ;
00080 ; ORG 0F000H ;START AT F000H
00090 ;
00100 ;*****
00110 ;* JUMP TABLE *****
00120 ;*****
00130 ;
00140 ENTRY0 JP RTN0 ;ROUTINE 0 ENTRY
00150 ENTRY1 JP RTN1 ;ROUTINE 1 ENTRY
00160 ENTRY2 JP 0000H ;SPARE
00170 ENTRY3 JP 0000H ;SPARE
00180 ENTRY4 JP 0000H ;SPARE
00190 ;
F000
10 REM ASSEMBLY PROGRAM ALREADY LOADED
20 REM BASIC MEMORY SIZE SET AT 0EFFFH
30 DEFUSR0 = &HF000: REM JUMP TABLE ENTRY FOR ROUTINE 0
40 DEFUSR1 = &HF003: REM JUMP TABLE ENTRY FOR ROUTINE 1
.
.
.
100 POKE &HF00F,B: REM SEND ROUTINE 0 DATA TO DATA TABLE
110 A=USR0(X): REM EXECUTE ROUTINE 0
120 C=PEEK(&HF010): REM GET THE ANSWER FROM DATA TABLE
.
.
.
200 POKE &HF011,D: REM SEND ROUTINE 1 DATA TO DATA TABLE
210 A=USR1(X): REM EXECUTE ROUTINE 1
220 E=PEEK(&HF012): REM GET THE ANSWER FROM DATA TABLE
.
.
.
300 END
(b)

```

Extend your reach ...make the knowledge connection.



Use your personal computer to reach Knowledge Index and, in minutes, you can locate information leading to answers on money management, medical research, electronics, child behavior, current affairs, and more.

It's a service from Dialog, the world's leading online information retrieval service, used for over a decade by corporations, libraries and professionals. Now, the same information is available to you nights and weekends at special low rates.

More than 5 million references and abstracts from thousands of journals, books and reports. Plus sources of reviews of software, books, films, and consumer products. And unique databases like Microcomputer Index and International Software Database.

A one-time initiation fee of only \$35 gets you a password, self-instructional user manual and two free hours of Knowledge Index—a value of over \$50! One low cost—40¢/minute—covers it all. There is no monthly minimum—you pay only for the time you actually use.

So, use Knowledge Index to extend your reach. To sign up or receive more information, return the coupon.

Sign me up for Knowledge Index for a one-time initiation fee of \$35, and bill connect-time charges at the rate of 40¢/minute to the credit card listed below.*

Charge my Visa MasterCard American Express

Account Number: _____ Expiration Date: _____

Send more information

Signature: _____

Name (please print): _____

Address: _____

City: _____ State: _____ Zip: _____

Telephone: (_____) _____

*Send my user manual immediately and activate my password as soon as you receive and accept my signed contract.

3460 Hillview Avenue, Palo Alto, CA 94304.
800/528-6050 x 415.

B-10/83

KNOWLEDGE INDEX

A Service of Lockheed Dialog

Circle 271 on inquiry card.

www.americanradiohistory.com

Listing 4: The listing 3a code after the addition of one line of code (line 430). Note that although all addresses after line 430 have changed, the interface to BASIC through the jump and data tables remains unchanged.

```

F052 3212F0      LD (DATA4),A      ;SAVE ANSWER
F055 C9         RET          ;RETURN TO BASIC
0000           END          ;END OF ROUTINES

```

```

00010 ;*****
00020 ;*****
00030 ;** ASSEMBLY LANGUAGE SUBROUTINE **
00040 ;** TO BE CALLED FROM BASIC **
00050 ;*****
00060 ;*****
00070 ;*****
00080 ;*****
00090 ;*****
00100 ;*****
00110 ;* JUMP TABLE
00120 ;*****
00130 ;*****
00140 ENTRY0 JP RTN0 ;ROUTINE 0 ENTRY
00150 ENTRY1 JP RTN1 ;ROUTINE 1 ENTRY
00160 ENTRY2 JP 0000H ;SPARE
00170 ENTRY3 JP 0000H ;SPARE
00180 ENTRY4 JP 0000H ;SPARE
00190 ;*****
00200 ;*****
00210 ;* DATA TABLE
00220 ;*****
00230 ;*****
00240 DATA1 DEFB 00H ;ROUTINE 0 DATA
00250 DATA2 DEFB 00H ;ROUTINE 0 ANSWER
00260 DATA3 DEFB 00H ;ROUTINE 1 DATA
00270 DATA4 DEFB 00H ;ROUTINE 1 ANSWER
00280 ;*****
00290 ;*****
00300 ;* ROUTINE 0
00310 ;*****
00320 ;*****
00330 RTN0 LD A,(DATA1) ;1ST ENTRY POINT
00340 LD B,05H ;IGNORE CODE

00430 ;*****
00440 AND 7FH ;* ADD NEW CODE *
00450 LD (DATA2),A ;SAVE ANSWER
00460 RET ;RETURN TO BASIC
00470 ;*****
00480 ;* ROUTINE 1
00490 ;*****
00500 ;*****
00510 RTN1 LD A,(DATA3) ;2ND ENTRY POINT
00520 SLA A ;IGNORE CODE

```

Listing 5: An assembly-language listing (a) and a BASIC program (b) that illustrate expansion of the number of USER calls available from BASIC to 255. The assembly-language listing shows the jump-table technique used in conjunction with the CLCINX routine (lines 340 to 450) to calculate the desired entry point.

```

(a)
00010 ;*****
00020 ;*****
00030 ;** ASSEMBLY LANGUAGE SUBROUTINE **
00040 ;** TO BE CALLED FROM BASIC **
00050 ;*****
00060 ;*****
00070 ;*****
00080 ;*****
00090 ;*****
00100 ;*****
00110 ;* JUMP TABLE
00120 ;*****
00130 ;*****
00140 ENTRY0 JP CLCINX ;CALCULATE INDEX
00150 ENTRY1 JP RTN1 ;ROUTINE 1 ENTRY
00160 ENTRY2 JP RTN2 ;ROUTINE 2 ENTRY
00170 ENTRY3 JP 0000H ;SPARE
00180 ENTRY4 JP 0000H ;SPARE
00190 ;*****
00200 ;*****
00210 ;* DATA TABLE
00220 ;*****
00230 ;*****
00240 INDEX DEFB 00H ;NO. OF ROUTINE
00250 DATA1 DEFB 00H ;ROUTINE 1 DATA
00260 DATA2 DEFB 00H ;ROUTINE 1 ANSWER
00270 DATA3 DEFB 00H ;ROUTINE 2 DATA
00280 DATA4 DEFB 00H ;ROUTINE 2 ANSWER
00290 ;*****
00300 ;*****
00310 ;* CALCULATE ENTRY FROM INDEX
00320 ;*****
00330 ;*****
00340 CLCINX LD A,(INDEX) ;GET ROUTINE NO.
00350 OR A ;IS IT ZERO?
00360 RET Z ;IF YES, RETURN
00370 LD H,00H ;ZERO H REGISTER
00380 LD L,A ;COPY INDEX TO L
00390 LD D,00H ;ZERO D REGISTER
00400 LD E,A ;COPY INDEX TO E
00410 ADD HL,DE ;DOUBLE INDEX
00420 ADD HL,DE ;HL = 3 X (INDEX)
00430 LD DE,ENTRY0 ;JUMP TABLE START

```

FOR ONE HALO OF A DEAL CALL US.

DISKETTES

Dysan SS/DD	31.00
Dysan DS/DD	42.95
Verbatim SS/DD	23.95
Verbatim DS/DD	39.00
Elephant SS/DD	22.95
Elephant DS/DD	29.00

DISKETTE STORAGE

5 1/4" Mini Plastic Case	1.95
5 1/4" Protector (50 Disk)	16.50
8" Protector (50 Disk)	18.50

MONITORS

NEC 12" Hi-Res Green	158.00
NEC 12" Econo Green	115.00
Sanyo 9" B/W	139.00
Sanyo 9" Green	149.00
Sanyo 12" Green	139.00
Sanyo 13" Color	399.00
USI 12" Amber (Gold)	159.00
Amdek Color I	326.00
Amdek Color II	739.00
Electrohome 13" Hi-Res	699.00

PRINTERS

NEC 8023	473.00
NEC 7710	2399.00
Okidata Microline 92	499.00
Okidata Microline 93	873.00
Smith Corona TPI	545.00
Star Micronics Gemini 10X	269.00
Star Micronics Gemini 15	375.00

PRINTER BUFFERS

Microfazer 8K	129.00
Microbuffer 16K	209.00
Microbuffer 32K	224.00
InLine 32K	224.00

MODEMS

Novation AppleCat II	279.00
Novation 212 AppteCat	569.00
Novation 212 Add On	335.00
Novation J-Cat	119.00
Hayes Micromodem II	279.00
Hayes Smartmodem	209.00
Hayes 1200B	489.00

DISK DRIVES

Micro Sci A40 W/O Cont	350.00
Micro Sci A40 W/Cont	429.00
Micro Sci A70 W/O Cont	488.00
Micro Sci A70 W/Cont	569.00
Rana Drive W/O Cont	339.00
Rana Drive W/Cont	409.00
Rana Disk Controller Card	95.00
Tandon TM-100-2	239.00
Tandon TM-55-2	239.00
Winchester 602	776.00
Winchester 603	873.00
Winchester 603E	971.00

HARDWARE

ABT Keypad (New)	98.00
M&R Superterm 80 x 24	248.00
M&R SuperMod RF Modulator	23.00
TG Game Paddles	26.50
TG Joysticks	39.00
TG Select A Port	39.00
Adam & Eve Game Paddles	26.50

Videx Keyboard Enhancer II	115.00
Videx Function Strip	69.00
Videx Soft Switch	27.50
MicroSoft Ram Card	79.00
MicroSoft Z-80 C/PM Card	244.00
MicroSoft Permium Pack	489.00

CALIFORNIA COMPUTER SYSTEMS

7710A Asyn.S. Interface	126.00
7712A Syn S. Interface	146.00
7721A P. Interface Std.	99.00

MOUNTAIN COMPUTERS, INC.

CPS Multi Function Card	130.50
MUSIC System w/Software	309.00
ROM Plus w/Keyboard Filter	155.00

SOFTWARE

Magic Window	74.00
DBase II (Z-80 Card Req.)	424.00
Home Accountant	55.00
Easy Writer Pro	129.00
Easy Mailer Pro	107.00
Lisa 2.5	55.00
Screenwriter II	95.00
PFS Report	74.00
PFS Filing System	79.00
PFS Graph	79.00
Z-Term (Z-80 Card Req.)	79.00
Z-Term Pro (Z-80 Card Req.)	124.00
ACCII Express	65.00
ASCII Pro	90.00
Transend II	105.00
DB Master	154.00
DB Master Utility I or II	65.00
DB Master Graphic Process	69.00
SuperCalc	127.00
SuperCalc II	172.00

VISI CORP.

VisiPlot	155.00
VisiTerm	74.00
VisiTrend/Plot	219.00
VisiDex	184.00
VisiCalc	184.00
VisiLink	184.00

MICROPRO

Desk Top Plan II	184.00
Wordstar	257.00
Mallmerge	169.00
Spellstar	169.00
Calcstar	104.00
Datatar	195.00
Supersort	169.00

APPLE GAMES

Raster Blaster	20.50
Swashbuckler	23.00
Snack Attack	19.75
Deadline	32.75
Zork I or II	26.50
Pool 1.5	23.00
Frogger	23.00

MUSE SOFTWARE

Robot Wars	29.75
Three Mile Island	29.75
Castle Wolfenstein	19.75
A.B.M.	19.00

BRODERBUND

Bandits	24.00
Chop Lifter	24.00
Midnight Magic	24.75
Apple Panic	22.75
Galaxy Wars	19.25
Space Quarks	19.75

ON-LINE SYSTEMS

Frogger	24.00
Crossfire	24.00
Wizard & Princess	26.50
Missile Defense	19.75
Softporn Adventure	23.00
Threshold	28.75
Time Zone	65.00
Ultima II	39.00
Jaw Breaker	21.75
Sabotage	16.50
Cannon Ball Blitz	23.00

SIRIUS SOFTWARE

Speakers	22.75
Space Eggs	22.75
Gorgon	29.50
Bandits	23.00
Jellyfish	19.75
Fly Wars	19.75
Beer Run	19.75
Lemmings	19.75
Cyclods	19.75

MICRO SOFT

Typing Tutor II	19.75
Olympic Decathlon	24.95

EDU-WARE

Algebra	27.95
Compu-Read	21.95
S.A.T. Work Skill	34.00
Fractions	34.00

ANGEL's COMPUTER PRODUCTS, INC. (213) 891-5546

All products guaranteed to be new and free from defects in material and workmanship for 30 days.

MasterCard and Visa accepted on all orders at no extra charge.

\$3.00 for standard UPS shipping and handling on orders under 50 lbs., delivered in the continental U.S. COD up to \$300.00. Call for other shipping and handling on FPO, APO, foreign, and orders over 50 lbs. California residents add 6.5% sales tax.

Prices quoted are for stock on hand and subject to change without notice. Limited quantities on some items. No returns on software that has been opened.

YOUR SATISFACTION IS OUR MAIN CONCERN

CP/M is a registered trademark of Digital Research

Circle 36 on inquiry card.

BYTE October 1983 507

Listing 6: A jump table of the BIOS for Digital Research's CP/M 2.2 operating system. The routines accessed from the jump table are customized for a specific hardware environment.

```

Listing 5a continued.
F024 19      ADD HL,DE      ;HL = ENTRY POINT
F025 E9      JP (HL)      ;GO TO JUMP TABLE
00440 ;
00450 ;
00460 ;
00470 ;
00480 ; * ROUTINE 1
00490 ;
00500 ;
00510 RTN1 LD A,(DATA1) ;2ND ENTRY POINT
00520 LD B,05H ;IGNORE CODE
.
.
.
F044 3211F0 LD (DATA2),A ;SAVE ANSWER
F047 C9      RET ;RETURN TO BASIC
00610 ;
00620 ;
00630 ;
00640 ; ***** ROUTINE 1 *****
00650 ; * ROUTINE 2
00660 ; *****
00670 ;
00680 RTN2 LD A,(DATA3) ;3RD ENTRY POINT
F04B CB27 SLA A ;IGNORE CODE
.
.
.
F067 3213F0 LD (DATA4),A ;SAVE ANSWER
F06A C9      RET ;RETURN TO BASIC
00830 ;
00840 ; END OF ROUTINES
(b)
10 REM ASSEMBLY PROGRAM ALREADY LOADED
20 REM BASIC MEMORY SIZE SET AT 0EFFFH
30 DEFUSR = &HF000: REM ENTRY POINT FOR INDEX ROUTINE
40 REM POKE NUMBER OF DESIRED ROUTINE AT 0F00FH
50 REM AND CALL USER0 TO EXECUTE
.
.
.
100 POKE &HF010,B: REM SEND DATA TO ROUTINE 1
110 POKE &HF00F,1: A=USR(X): REM EXECUTE ROUTINE 1
120 C=PEEK(&HF011): REM GET THE ANSWER
.
.
.
200 POKE &HF012,D: REM SEND DATA TO ROUTINE 2
210 POKE &HF00F,2: A=USR(X): REM EXECUTE ROUTINE 2
220 E=PEEK(&HF013): REM GET THE ANSWER
.
.
.
300 END

```

Statpro™

The most comprehensive statistics and graphics ever developed for and sophisticated database workstation the personal computer.

Years of research, development, and field testing have resulted in the most extensive statistics and graphics database program specifically designed for the personal computing environment. STATPRO™ provides the data analysis capabilities and flexibility previously available only on a large computer. Researchers, business professionals, and other data analysts will welcome the breadth yet simplicity of this program! STATPRO requires no previous computer experience, no special command language. Single keystrokes access all of the data manipulation, statistics, and graphics power of STATPRO.

STATPRO allows easy access to its extensive numerical data capabilities.

The strength of STATPRO is found in the functions of its user friendly, menu-driven database. You can easily learn to enter and edit, manipulate, transform, and print out data. STATPRO's searching capabilities allow these functions to be performed on all your data or a user defined subset of your data.

Statistics Modules Menu

- A) DESCRIPTION
- B) REGRESSION
- C) ANOVA
- D) TIME SERIES
- E) MULTIVAR

(ESC)) Exit to Master Menu

Choice -> []

Transformations and over 400 conversions are available. You can place the results of these transformations into the same field or any other field in STATPRO's database.

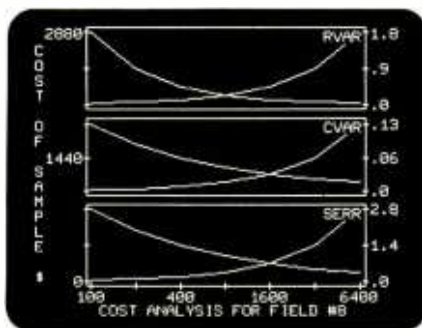

STATPRO offers a comprehensive collection of statistical procedures.

The statistics component of STATPRO contains a multitude of procedures, grouped into the following modules:

Descriptive: Contingency analysis, cross tabulation, normality tests; descriptive, comparative, range and non-parametric statistics.

Regression: Linear, non-linear, stepwise, and multiple regressions; residual analysis and statistical matrices.

Analysis of Variance: Single and nested classifications, two and three way equal and unequal sample size and non-parametric ANOVA.

Time Series: Moving averages, multi-stage least squares, fitted polynomials and trig functions, additive and multiply forecasting.

Multivariate: Principal components, factor, orthogonal factor, oblique factor, pair-weighted cluster, discriminant function, multiple contingency, and canonical correlation analysis.

STATPRO provides graphic representation of your data in minutes.

STATPRO graphics plot *all* the results of your STATPRO statistical analyses including scatter, triangle regression, and box plots; pie-

charts, histograms, and dendograms. Further, with STATPRO you can custom edit with any of four character sets from the keyboard. You can also edit using paddles, joystick or special graphics commands. Mix text with data fields. Place multiple plots on each screen. Define your axis limits.

You can save your graphics on a disk for a multiple color "slide show" presentation, or print them out through a variety of compatible printers.

STATPRO documentation wraps up the package.

Although STATPRO software is essentially self-documenting, complete print documentation is provided. This includes a walk-through Introductory Tutorial, a Menu Chart, and a comprehensive User's Guide for each STATPRO component.

STATPRO currently runs on all versions of the Apple® II personal computers. It will be available for the IBM® PC in September.

To find out more about **Statpro: The Statistics and Graphics Database Workstation**, contact your local dealer, or

Call us toll-free at

800-322-2208

In Massachusetts call (617) 423-0420.

You can also call us toll-free for information on corporate purchase through our National Account Program.

 **Wadsworth Electronic Publishing Company**
Statler Office Building
20 Park Plaza, Boston, MA 02116

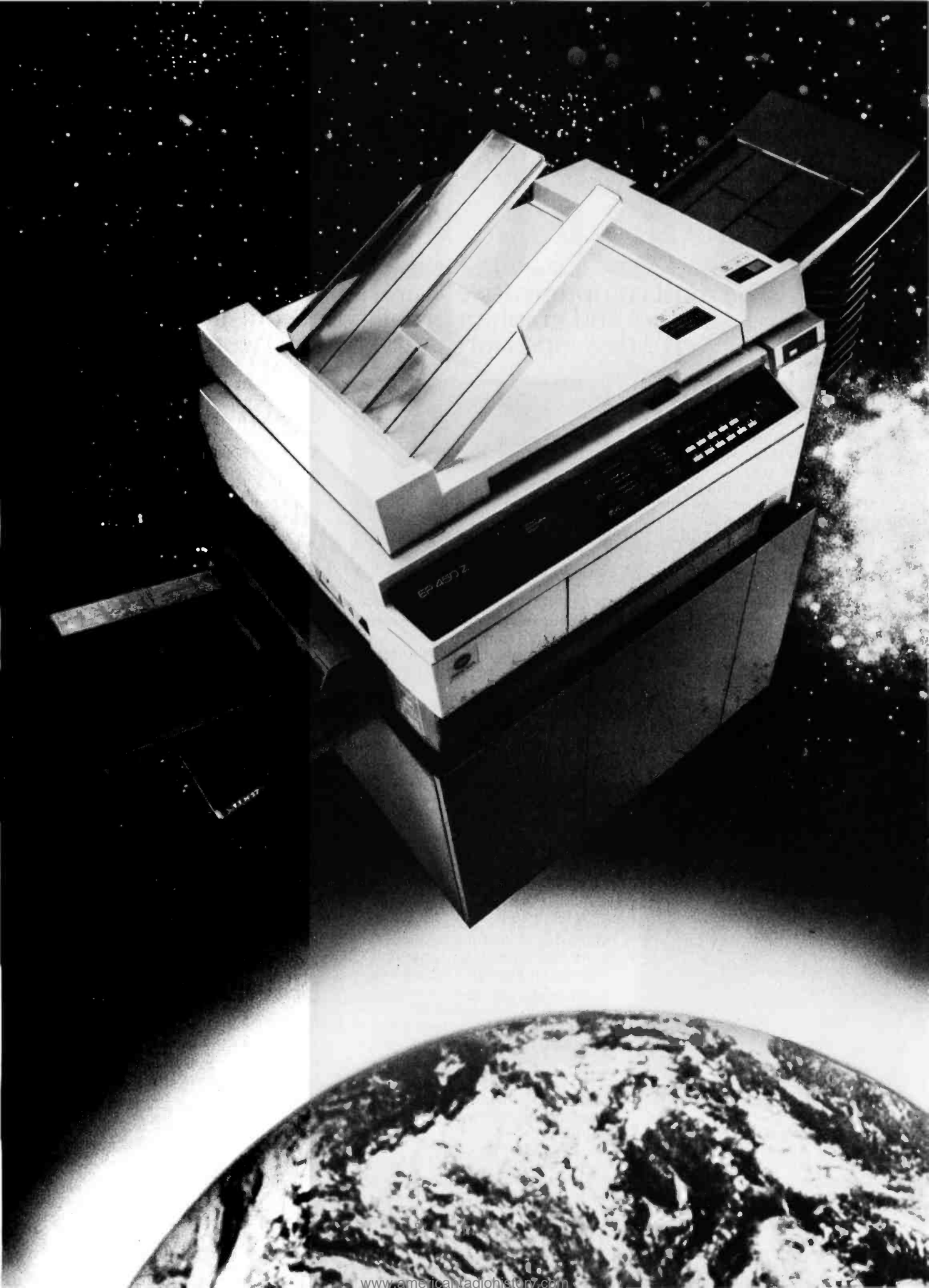

THERE'S NO OTHER COPIER ON EARTH LIKE IT.

It's only fair to warn you.

The first few times you use the new Minolta Beta 450Z, you will simply be astonished.

The 450Z does things no other copier has ever done before. Because it has features no other copier ever had before.

Like auto magnification. Which allows the 450Z with its automatic document feeder to take a stack of different size originals and automatically reduce or enlarge them to uniform size copies. A feature that will make life considerably easier if you have to make presentations or produce reports.

If, on the other hand, you simply want to make copies of that stack of different size originals, the 450Z has auto paper select to automatically select the correct paper size.

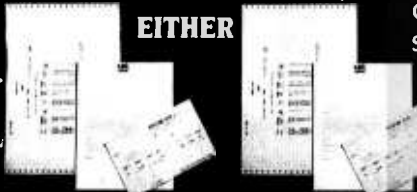

OR



Like other copiers the Beta 450Z lets you choose from four preset image sizes.

But unlike other copiers, it has a unique variable magnification zooming lens that gives you a virtually limitless range of copy sizes.

Because you can program any sizes you like into the 450Z. From almost 50% larger than the original to 50% smaller.

The 450Z does other wonderful things, like "beeping" if you forget your original on the machine.

And if you leave your copies in the sorter, the 450Z will call this to your attention with a flashing light.

There is also a remarkably specific self-diagnostic system that allows you or the serviceman, on the rare occasions when you will need him, to quickly find and correct any difficulty that may occur.

In addition, Beta has a unique, dependable toner cartridge. For an easier, clean hands operation.

If you need to expand capacity with an automatic document feeder or sorter, the 450Z has a full system of design-integrated accessories. And because they're made only for Beta they give you smoother, significantly more trouble-free operation.

If you don't need reduction, enlargement or auto magnification, but want the other advantages of Beta, ask your dealer about our Beta 450 (without the Z').

Either way you'll get copies that are out of this world.

For a demonstration of the 450Z get in touch with your Minolta dealer. Look in the Yellow Pages under the Minolta trademark. Or call toll free 800-526-5256. In New Jersey, 201-342-6707.



MINOLTA

Circle 313 on inquiry card.

Please have my dealer contact me for a demonstration of the new Minolta Beta 450Z.

Please send me more information.

Name _____

Title _____

Company _____

Address _____

City _____ State _____

Zip _____ Telephone _____

Mail to Minolta Corporation
Business Equipment Division
101 Williams Drive
Ramsey, N.J. 07446.



BY-9

© 1981 Minolta Corporation

Listing 1a: The BASIC-language portion of the routines to test and demonstrate the Micro D-Cam.

```

10 REM MICRO DCAM DEMONSTRATION
15 REM PROGRAM
20 REM
25 REM COPYRIGHT (C) 1983 BY
30 REM CIRCUIT CELLAR, INC.
35 REM
40 HGR : TEXT : HOME
50 PRINT CHR$(4)*BLOAD MICRO D
   CAM"
60 INPUT "ENTER CAMERA SLOT: ";S

```

```

70 IF SL < 1 OR SL > 7 THEN 60
80 POKE 770,SL : 16: REM SLOT NU
   HBER
90 POKE 768,0: POKE 769,1: REM E
   XPOSURE TIME
100 POKE 771,0: REM UPPER 1/3 OF
   SCREEN
110 CALL 4096: REM UPDATE SCR
120 IF PEEK (773) = 0 THEN 130:
   REM CHECK FOR KEYPRESS
130 IF PEEK (772) = 209 THEN TEXT
   : HOME : END : REM CHECK FOR
   'Q'
140 GOTO 110

```

Listing 1b: Micro D-Cam control subroutines, written in 6502 assembly language, called as a machine-language module by the BASIC routine of listing 1.

```

:ASM
1 *****
2 * MICRO DCAM SUPPORT ROUTINES
3 *
4 * COPYRIGHT (C) 1983
5 * BY CIRCUIT CELLAR, INC.
6 *
7 * WHEN CALLED, THIS ROUTINE READS
8 * AN IMAGE FROM THE CAMERA AND
9 * DISPLAYS IT ON THE APPLE'S HI-RES
10 * GRAPHICS SCREEN
11 *****

```

```

12 DRB $1000
13 EBU $C010
14 EBU $C000
15 EBU $C030
16 EBU $C050
17 EBU $C051
18 EBU $C053
19 EBU $C054
20 EBU $C057
21 EBU $C08E
22 EBU $C0BF
23 *
24 SOAKTIME EBU $300
25 SLOTADR EBU $302
26 ROWSTART EBU $303
27 KEY EBU $304
28 KEYEXIT EBU $305
29 *
30 RADR EBU $06
31 CTR EBU $08
32 YREG EBU $19
33 *
34 JSR SETGR
35 JSR ACIACLR
36 LDA #$D3
37 JSR SENDCMD
38 JSR SOAK
39 LDA #$C0
40 JSR SENDCMD
41 LDY #0
42 LDY #0
43 LDA ROMPTR,X
44 CLC
45 ADC ROWSTART
46 STA RADR
47 INX
48 LDA ROMPTR,X
49 STA RADR+1
50 INX
51 GET
52 LDY SLOTADR
53 LDA STATUS,Y

```

```

;SET UP FOR HIRES PAGE1
;FLUSH THE INPUT BUFFER
;SEND CMD TO SOAK W/O SEND
;SEND IMAGE W/O SOAK
;(ALT,WIDEPIX,7BIT-256X64)
;INITIALIZE THE ROW INDEX
;INIT COLUMN INDEX (Y)
;BUILD BASE ADDRS FOR CUR ROW
;0-SELECT UPPER 1/3 OF SCREEN
;$28-MID 1/3,$50-BOT 1/3
;RADR HAS ADDRS OF CUR ROW
;PNT X TO NXT ADDRS IN ROMPTR
;SET NEXT BYTE FROM CAMERA
;LOAD OFFSET TO CAMERA SLOT
;CHECK IF NEXT BYTE ARRIVED

```

Everybody's making money selling microcomputers. Somebody's going to make money servicing them.

Now NRI Trains You At Home To Make Money Servicing, Repairing, and Programming Personal and Small Business Computers

Seems like every time you turn around, somebody comes along with a new computer for home or business use. And what's made it all possible is the amazing micro-processor, the tiny little chip that's a computer in itself.

Using this new technology, the industry is offering compact, affordable computers that handle things like payrolls, billing, inventory, and other jobs for business of every size...perform household functions including budgeting, environmental systems control, indexing recipes. And thousands of hobbyists are already owners, experimenting and developing their own programs.

Growing Demand for Computer Technicians

This is only one of the growth factors influencing the increasing opportunities for qualified computer technicians. The U.S. Department of Labor projects over a 600% increase in job openings for the decade. Most of them are *new* jobs created by the expanding world of the computer.

Learn At Home to Service Any Computer

NRI can train you for this exciting, rewarding field. Train you at home to service not only micro-computers, but word processors and data terminals, too. Train you at your convenience, with clearly written "bite-size" lessons that you do evenings or weekends, without going to classes or quitting your present job.

Your training is built around the latest model of the world's most popular computer. It's the amazing TRS-80™ Model 4, now with disk drive and the capabilities and features to perform a host of personal and business functions. No other small computer has so much software available for it, no other is used and relied on by so many people. And it's yours to keep for personal and business use.

You get plenty of practical experience. Under NRI's carefully planned training, you even install a *disk drive* verifying at each step its operation. Using the NRI Discovery Lab® that also comes as part of your course, you build and study circuits ranging from the simplest to the most



advanced. You analyze and troubleshoot using the professional 4-function LCD digital multimeter you keep to use later in your work. Then you use the lab and meter to actually access the interior of your computer...build special circuits and write programs to control them. You "see" your computer at work and demonstrate its power.

Same Training Available With Color Computer

NRI offers you the opportunity to train with the TRS-80 Color Computer as an alternative to the Model 4. The same technique for getting inside is enhanced by using the new NRI-developed Computer Access Card. Only NRI offers you a choice to fit your specific training needs.

Become the Complete Computer Person

In addition to training in BASIC and advanced machine language, you gain hands-on experience in the operation and application of the latest computers for both business and personal jobs. You're trained to become the fully rounded, new breed of technician who can interface with the operational, programming, and service facets of all of today's computers. You're ready to take your place in the new electronic age.

Other Opportunities

NRI has been giving ambitious people new electronic skills since 1914. Today's offerings also include TV/Audio/Video Systems servicing with training on our exclusive Heath/Zenith computer-programmable 25" diagonal color TV...Industrial Electronics, Design Technology...and other state-of-the-art courses.

The Catalog Is Free. The Training is Priceless.

Send the postage-paid card for our 104-page catalog showing all courses with equipment and complete lesson plans. There's no obligation other than to yourself. See how NRI can help you take advantage of the exciting job and earnings opportunities in the exploding field of micro-computers. If card has been removed, please write to us.



NRI Schools
McGraw-Hill Continuing
Education Center
3939 Wisconsin Ave.
Washington, DC 20016

We'll give you tomorrow.

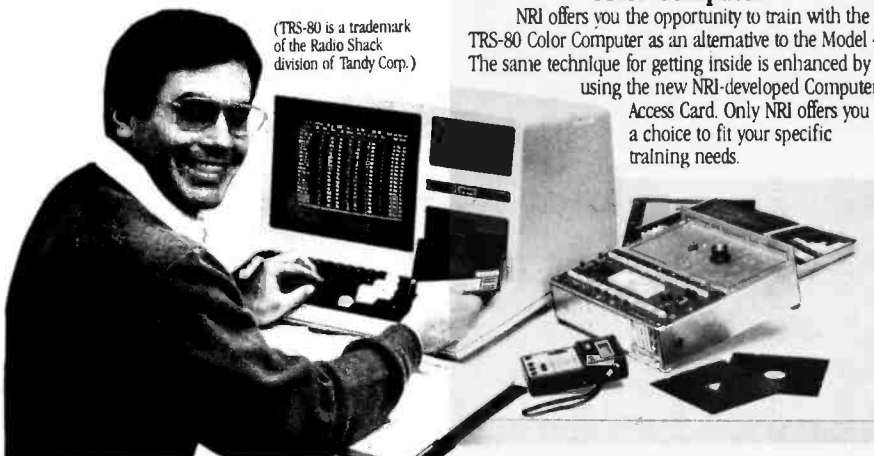

(TRS-80 is a trademark of the Radio Shack division of Tandy Corp.)

The IBM Personal Computer Work Station. It's optional. (But essential.)

Now, we could hard-sell you on its features. Or we could soft-sell you on its virtues. Instead, we're going to level with you.

You don't have to buy it.

But we have a hunch that the more you know about the IBM Synergetix® PC Work Station the more you'll wonder how your business ever managed without it.

Necessity was surely the mother of this invention.

For as more and more businesses come to rely on the personal computer, new and extraordinary demands are being placed on the work environment itself.

The IBM PC Work Station was specifically developed to meet the challenges of today's technology. And scientifically designed to satisfy the various needs of the people who use it.

It's not just another pretty desk.

First and foremost, the IBM PC Work Station provides a convenient and compact work space that instantly opens up to expand your work area.

In addition, the IBM PC Work Station offers added mobility for your personal computer. So you get more mileage out of your investment as it moves from office to office, person to person, solving problem after problem.

And since your personal computers are as vulnerable as they are valuable, the IBM PC Work Station also functions as a security device.

It deters pilferage by providing a self-contained lockable storage compartment for your CPU, software, keyboard, printer, program books and diskettes.

It also protects valuable information, prohibiting unauthorized access to confidential computer data by keeping it all secure under lock and key.

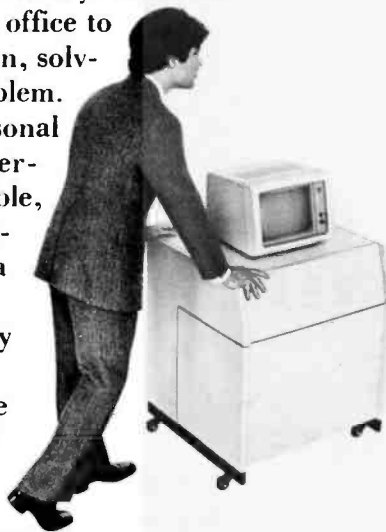
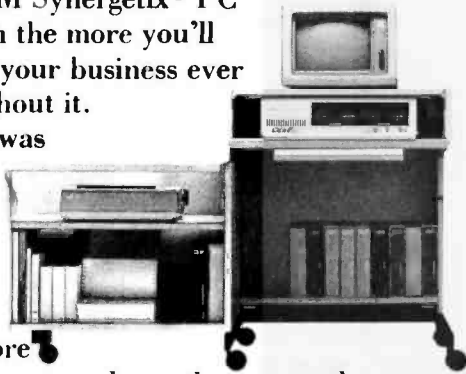

Last but not least, the IBM PC Work Station is human-factor engineered to meet IBM's strict ergonomic standards for operator comfort. For as you know, the more comfortable

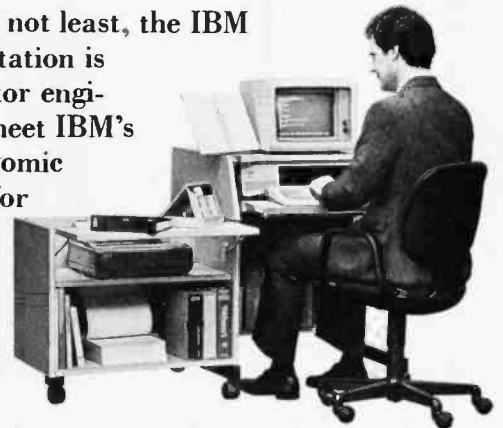

people are, the more productive they can be.

There's one more important feature to our PC Work Station. It comes equipped with the added assurance of IBM quality. But then, that comes standard on all IBM products.

If all this hasn't convinced you that our PC

Work Station is as essential as it is exceptional, we're sure the price tag will. And IBM's quantity discounts make it absolutely irresistible.

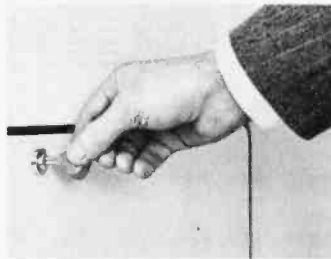

To find out just how irresistible (or for additional information) call *IBM Direct* toll free at 1 800 631-5582* ext. 40 or visit one of our IBM Product Centers. Or send in the coupon below.

The IBM Personal Computer Work Station—business people are finding it's one of those luxuries they just can't live without.

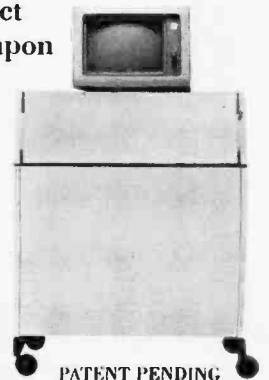

IBM PERSONAL COMPUTER WORK STATION		
Mail to: IBM Corporation, Attn: IBM Direct, One Culver Road, Dayton, New Jersey 08810		
NAME _____	TITLE _____	
COMPANY _____	TELEPHONE _____	
ADDRESS _____		
CITY _____	STATE _____	ZIP _____

*In Alaska and Hawaii call 1 800 526-2484 ext. 40.

138 †	LDA	AD 01 03	SOAK	LDA	SOAKTIME+1	;SOAK FOR NUMBER OF MS	HEX	002100250029002B003100350039003D
139	SOAK	STA	CTR+1	STA	CTR+1	;SPECIFIED BY SOAKTIME		
140	INC	CTR+1	INC	CTR+1				
141	LDA	SOAKTIME	LDA	SOAKTIME				
142	STA	CTR	STA	CTR				
143	INC	CTR	INC	CTR				
144	LDA	SOAKTIME	LDA	SOAKTIME				
145	BNE	SOAK1	BNE	SOAK1				
146	LDA	SOAKTIME+1	LDA	SOAKTIME+1				
147	BEG	SOAK2	BEG	SOAK2				
148	JSR	MSEC	JSR	MSEC				
149	DEC	CTR	DEC	CTR				
150	BNE	SOAK1	BNE	SOAK1				
151	DEC	CTR+1	DEC	CTR+1				
152	BNE	SOAK1	BNE	SOAK1				
153	RTS	RTS	RTS					
154	SOAK2	SOAK2						
155 †								
156	MSEC	MSEC	STY	YREG				
157			LDY	#199				
158	MSEC1	MSEC1	DEY					
159	BNE	MSEC1	BNE	MSEC1				
160	LDY	YREG	LDY	YREG				
161	RTS	RTS	RTS					
162 †								
163	ROMPTR	HEX	002000240028002E003000340038003C					
164								
165								
166								
167								
168								
169								
170								
171								

Introducing a sensible solution to the problems of dBASE II.™

	dBASE II	The Sensible Solution
Records Per File	65,535	999,999
Maximum Record Size	1,024 bytes	1,536 bytes
Fields Per Record	32	384
Key Fields Per File	7	10
Number of Files Simultaneously Accessible	2	10
Number of Screens Per Program	Limited by system memory	Limited only by system storage
Data Dictionary	No	Yes

We don't mean to debase dBASE II, but if you're looking for a data base manager that's long on features, dBASE II can come up a little short.

For instance, a single dBASE II record can only contain 32 fields. And when you need to share information between one file and another, you can only access two at a time.

So, as good as dBASE II is, its limitations can quickly paint you into an electronic corner.

And that's why we created *The Sensible Solution*.

Finally A sensational relational.

Along with all the usual things you expect from a data base manager, *The Sensible Solution* lets you handle the kind of tough assignments that dBASE II can't:

You can design data files with more than 300 variables. You can create reports using 10 different files at once. You can even set up file locking for multi-user computers.

Ready to get down to business.

A data base manager without ready-to-run application programs is hardly worth the disk it's copied on.

So, along with *The Sensible Solution*, you can also add *The Sensible Solution Bookkeeper*™ or *Sensible Management*™, our complete one-entry accounting and management system.

They're both affordable. Business-tested. And supplied with source code so you can make your own modifications.

A sensible trial offer.

When you purchase *The Sensible Solution*, we'll send along a special trial disk that lets you create forms and enter a limited number of records. If, after 30 days, you're not satisfied, just return the unopened master system disk for a full refund.

So why not take us up on our trial offer? You've got nothing to lose.

Except the problems of dBASE II.

The Sensible Solution™

To order, write or call: O'Hanlon Computer Systems, 11058 Main Street, Bellevue, WA 98004 USA, Phone (206) 454-2261. Prices: *The Sensible Solution*—\$695, *Sensible Solution Bookkeeper*—\$495, *Sensible Management*—\$895. In Washington, add 6.5% state tax. VISA, Mastercard and dealer inquiries welcome.

dBASE II is a registered trademark of Ashton-Tate. Sensible Solution, Sensible Solution Bookkeeper and Sensible Solution Management are trademarks of O'Hanlon Computer Systems, Inc.

```

11A7: 3C 172
11A8: 28 21 28
11A9: 25 28 29
11AA: 28 2D 28
11AB: 31 28 35
11AC: 28 39 28
11AD: 3D 173
11AE: AB 21 AB
11AF: 25 AB 29
11B0: AB 2D AB
11B1: 31 AB 35
11B2: AB 39 AB
11B3: 3D 174
11B4: 28 22 28
11B5: 26 28 2A
11B6: 28 2E 28
11B7: 32 28 36
11B8: 28 3A 28
11B9: 3E 175
11BA: AB 22 AB
11BB: 26 AB 2A
11BC: AB 2E AB
11BD: 32 AB 36
11BE: AB 3A AB
11BF: 3E 176
11C0: 28 23 28
11C1: 27 28 28
11C2: 28 2F 28
11C3: 33 28 37
11C4: 28 3B 28
11C5: 3F 177
11C6: AB 23 AB
11C7: 27 AB 28
11C8: AB 2F AB
1201: 33 AB 37
1204: AB 3B AB
1207: 3F 178
    
```

```

HEX 4B20A824A828A82CA830A834A838A83C
HEX 282128252829282D283128352839283D
HEX 4B21A825A829A82DA831A835A839A83D
HEX 28222826282A282E28322836283A283E
HEX A822A826A82AA82EA832A836A83AA83E
HEX 28232827282B282F28332837283B283F
HEX A823A827A82BA82FA833A837A83BA83F
    
```

--END ASSEMBLY--

ERRORS: 0

520 BYTES

SYMBOL TABLE - ALPHABETICAL ORDER:

ACTIACLR	=\$10BF	BEEP	=\$C030	CLR1	=\$10AC	CTR	=\$08
DATA	=\$C08F	GET	=\$1027	GMODE	=\$C050	GRCLR	=\$10A1
HBR	=\$C057	KEY	=\$0304	KEY1	=\$108E	KEYCLR	=\$C010
KEYEXIT	=\$0305	KEYHIT	=\$C000	MIXED	=\$C053	MSEC	=\$10FE
MSEC1	=\$1102	NDOME	=\$1067	NEWR0W	=\$1015	NORM1	=\$103A
NORM2	=\$104D	NORM3	=\$1053	NORM4	=\$105E	NSTART	=\$1003
PAGE1	=\$C054	RADR	=\$06	ROMPTR	=\$1108	ROWSTART	=\$0303
SEND1	=\$10CC	SENDCHD	=\$10C6	SET6R	=\$1089	SLOTADR	=\$0302
SOAK	=\$10DA	SOAK1	=\$10F2	SOAK2	=\$10FD	SOAKTIME	=\$0300
STATUS	=\$C08E	THODE	=\$C051	YREG	=\$19		

SYMBOL TABLE - NUMERICAL ORDER:

RADR	=\$06	CTR	=\$08	YREG	=\$19	SOAKTIME	=\$0300
SLOTADR	=\$0302	ROWSTART	=\$0303	KEY	=\$0304	KEYEXIT	=\$0305
NSTART	=\$1003	NEWR0W	=\$1015	GET	=\$1027	NORM1	=\$103A
NORM2	=\$104D	NORM3	=\$1053	NORM4	=\$105E	NDONE	=\$1067
KEY1	=\$108E	ACTIACLR	=\$10BF	GRCLR	=\$10A1	CLR1	=\$10AC
SET6R	=\$1089	SENDCHD	=\$10C6	SEND1	=\$10CC	SOAK	=\$10DA
SOAK1	=\$10F2	SOAK2	=\$10FD	MSEC	=\$10FE	MSEC1	=\$1102
ROMPTR	=\$1108	KEYHIT	=\$C000	KEYCLR	=\$C010	BEEP	=\$C030
GMODE	=\$C050	THODE	=\$C051	MIXED	=\$C053	PAGE1	=\$C054
HBR	=\$C057	STATUS	=\$C08E	DATA	=\$C08F		

Listing 2a: The BASIC portion of the GREY16 program that produces dithered gray-scale output on the Apple II's video screen from the Micro D-Cam's output.

```

10 REM GREY16BAS
12 REM
13 REM COPYRIGHT (C) 1983
15 REM BY CIRCUIT CELLAR, INC.
17 REM
18 REM *LOAD ROUTINES AND INITIA
    LIZE VARIABLES
19 REM
    
```

Will This Happen to You?

NOT IF YOU BUY YOUR PRINTER FROM...

THE PRINTER STORE

After reading this issue of *BYTE Magazine*, you are now fully aware of the many outstanding printers on the market today. But what you might not be aware of is that the printer you like best, might not be compatible with your computer and software. (The picture above is good example of printer incompatibility). At the **Printer Store**, we specialize in printers, so our experienced professional staff can help you choose the right printer for your personal and business needs. If you want the **Best Value, Low Price, Product Availability, and Support**, call The Printer Store and ask us about:



- FREE TECHNICAL CONSULTATION
- FULL AFTER SALE SUPPORT
- FULL FACTORY AUTHORIZED SERVICE

DOT MATRIX PRINTERS

EPSON SERIES	
FX 80	\$ CALL
FX 100	\$ CALL
OKIDATA SERIES	
82A	\$ CALL
83A	\$ CALL
92A	\$ CALL
93A	\$ CALL
84 (parallel)	\$ CALL
C. ITOH SERIES	
8510 Prowriter	\$ 395
Prowriter II	\$ CALL
New! Banana	\$ 239
IDS SERIES	
Microprism 480	\$ CALL
Prism 80	\$ CALL
Prism 132	\$ CALL
GEMINI SERIES	
Gemini 10X	\$ CALL
Gemini 15	\$ CALL
NEC 8023	\$ 419
Toshiba P 1350	\$ 1750

LETTER QUALITY PRINTERS

BROTHER SERIES	
HR-1 (parallel)	\$ CALL
HR-1 (serial)	\$ CALL
HR-15	\$ CALL
COMREX SERIES	
CR-1 (parallel)	\$ 795
CR-1 (serial)	\$ 865
CR-2	\$ CALL
C. ITOH SERIES	
F-10 40 CPS	\$ CALL
F10 55 CPS	\$ CALL
Daisywriter 48K	\$ CALL
NEC SERIES	
3510	\$ CALL
3530	\$ CALL
3550	\$ CALL
7710	\$ 2425
7720	\$ 2900
7730	\$ 2400
NEC Accessories	\$ CALL

C. ITOH 8510 Prowriter



- 120 CPS - 1.3K Buffer - 144x60 dots 1 inch Nx9 dot matrix - Proportional Spacing - 8 Character sizes - 5 unique alphabets - Greek character set - Graphic symbols - bi-directional, logic-seeking - Adjustable tractors - Single-sheet friction feed - Vertical & horizontal tabbing.

C. ITOH 8510 Prowriter List \$795 **\$ 395**

BROTHER HR-1



- 16 CPS - Bi-directional - Super and Subscript
 - IBM Selectric type ribbon - Prints up to 6 copies
 - Ideal for word processing
- Parallel List 1100 **\$ Call**
Serial List 1200 **\$ Call**

INTERFACE EQUIPMENT

Apple Duplicator	\$ 145	Printer Stands: large	\$ 95
Grappler Plus	\$ CALL	Printer Stands: small	\$ 25
Complete stock of Epson Accessories	\$ CALL	Printer Ribbons	\$ CALL
Custom Printer Cables for Apple, Atari, IBM	\$ CALL	Printer Sound Enclosure	\$ CALL
TRS-80	\$ CALL	Vic 20/Comm. 64 Interface	\$ CALL

PRINTERS/TYPEWRITERS

We specialize in typewriters that can be used as printers. Please call for pricing and information.

- 1) LOW PRICES
- 2) SAME DAY SHIPPING
- 3) FREE TECHNICAL SUPPORT
- 4) FULL SERVICE OPTION

We carry a full line of Cables and Accessories
Call (714) 241-0701 and ask us about...

PHONE REBATE

THE Printer

We are so confident of our LOW PRICES and SUPPORT that we are going to ask you to make the initial investment by calling us. In return, when you buy your printer from us, we will rebate the cost of your call and deduct it from your invoice.

HOW TO ORDER: Our phone lines are open from 8 a.m. to 6 p.m. PST, Monday-Friday. We accept VISA, MASTERCARD (at no extra charge), personal checks take two weeks to clear. COD's accepted. Same-day shipment on orders placed before 1 p.m. Manufacturer's warranty applicable on all equipment. Prices subject to change.

Circle 373 on inquiry card.

STORE - 2720 S. Harbor Blvd., Suite E, Santa Ana, CA 92704

© The Printer Store, 1983

```

20 HGR : TEXT : HOME : PRINT CHR$
  (4)"LOAD GREY16-48K"
40 NRH = 4096:FULL = 4099:GY = 41
  02
50 CAM = NRH
60 SOAK = 256:LO = 128:HI = 384
70 INC = (HI - LO) / 15
80 SL = 768:SH = 769:ST = 770:SP =
  771:KEY = 772:KP = 773:EI =
  774
90 HOME : INPUT "ENTER CAMERA S
  LOT: ";SN: IF SN < 1 OR SN >
  7 THEN 90
100 POKE ST,SN : 20: REM "SLOT N
  UMBER
110 POKE SP,0: REM "SCREEN POSIT
  ION
117 REM
118 REM "KEYBOARD PROCESSOR SEC
119 REM
120 POKE SH, INT (SOAK / 256): POKE
  SL,SOAK - INT (SOAK / 256) :
  256: REM "SOAK TIME
130 HOME : VTAB 21: PRINT TAB(
  11);"CURRENT EXP: "SOAK" MS
  ": PRINT "LO EXP: "
  ;LO;" MS "; TAB( 24);"HI EX
  P: ";HI;" MS "
140 CALL CAM: REM "READ CAMERA A
  ND DISPLAY PICTURE IN CURREN
  T MODE
150 IF NOT ( PEEK (KP)) THEN 14
  0: REM "CHECK FOR KEYPRESS
160 KEY$ = CHR$ ( PEEK (KEY) - 1
  28)
170 IF KEY$ = "E" THEN 400: REM
  "CHANGED EXPOSURE
180 IF KEY$ = "Q" THEN TEXT : HOME
  : END : REM "QUIT PROGRAM
190 IF KEY$ = "N" THEN CAM = NRH
  : HGR : REM "NORMAL SIZE
  
```

```

200 IF KEY$ = "F" THEN CAM = FULL
  L: HGR : REM "FULL SIZE
210 IF KEY$ = "G" THEN GOSUB 30
  0: REM "CREATE GREYSCALE PIC
220 IF KEY$ = "S" THEN GOSUB 60
  0: REM "SAVE PICTURE
230 GOTO 120
297 REM
298 REM "CREATE GREYSCALE PIC
299 REM
300 HOME : VTAB 22: PRINT "COUNT
  DOWN: ";
310 POKE SL,LO - INT (LO / 256)
  : 256: POKE SH, INT (LO / 2
  56): POKE EI,INC: REM "POKE
  STARTING EXPOSURE AND EXPOSU
  RE INCREMENT
320 CALL GY: REM "CREATE PIC
330 HOME : VTAB 22: PRINT "HIT '
  S' TO SAVE,": PRINT " ANY OT
  HER KEY TO CONTINUE.": GET K
  EY$
340 RETURN
397 REM
398 REM "CHANGE EXPOSURE
399 REM
400 HOME : VTAB 22: PRINT "CHANG
  E CURRENT, LO, OR": INPUT "
  HI EXPOSURE? (C,L,H): ";CH$
  410 IF CH$ = "" THEN 120
  420 IF CH$ < "C" THEN 460
  430 INPUT "ENTER NEW CURRENT: ";
  NE$: IF NE$ = "" THEN 540
  440 NE = VAL (NE$): IF NE < 1 OR
  NE > 8000 THEN 430
  450 SOAK = NE: GOTO 540
  460 IF CH$ < "L" THEN 500
  470 INPUT "ENTER NEW LO: ";NE$: IF
  NE$ = "" THEN 540
  480 NE = VAL (NE$): IF NE < 1 OR
  NE > 8000 OR NE > HI THEN 47
  
```

```

0
490 LO = NE: GOTO 540
500 IF CH$ < "H" THEN 400
510 INPUT "ENTER NEW HI: ";NE$: IF
  NE$ = "" THEN 540
520 NE = VAL (NE$): IF NE < 1 OR
  NE > 8000 OR NE < LO THEN 51
  0
530 HI = NE
540 INC = (HI - LO) / 15
550 GOTO 120
597 REM
598 REM "SAVE PICTURE ON DISK
599 REM
600 HOME : VTAB 22: PRINT "ENTER
  A NAME FOR: INPUT "THE PIC
  TURE: ";NA$
610 IF LEN (NA$) < = 0 THEN RETURN
620 PRINT CHR$ (4)"BSAVE "NA$",
  A$2000,L$2000"
630 HOME : RETURN
  
```

Listing 2b: Assembly-language listing of the machine-code portion of the GREY16 program, called from BASIC.

```

1 *****
2 :
3 : GREY16-48K
4 :
5 : COPYRIGHT (C) 1983
6 : BY CIRCUIT CELLAR, INC.
7 :
8 *****
9 :
10 ORG $1000
11 KEYHIT EBU $C000
12 KEYCLR EBU $C010
13 BEEP EQU $C030
14 GMODE EBU $C050
15 TMODE EBU $C051
  
```



One company has sold more printers
to this planet than anybody.

Epson.

By now, that shouldn't come as any surprise. After all, we *invented* digital printers for the 1964 Tokyo Olympics.

Since then, we've built more print mechanisms than the rest of the world combined. Including the world's smallest printers, the world's most reliable printers and the world's first disposable print head.

And today we are proud — but not surprised — to say that the world's best selling printers for small computers have the Epson name right on the front.

But the really amazing fact about Epson printers is this: they don't cost any more than other printers. In fact, they

frequently cost less.

Here's how we got to be the world's best-selling printers: by building a quality product, by pricing it fairly and by standing behind it. That's the way we've done business for almost 20 years.

Only one printer can claim to be "number one." And measured by popular acceptance, by technological innovation, by honest-to-goodness value, not to mention sheer weight of numbers, that printer is Epson.



*Number One.
And built like it.*

EPSON
EPSON AMERICA, INC.
3415 Kashiwa Street
Torrance, CA 90505

New Epson RX and FX dot matrix printers. At computer stores now.

Please call (800) 421-5426 for the dealer nearest you. In California, (213) 539-9140.

```

16 MIXED EQU $C053
17 PAGE1 EQU $C054
18 HGR EQU $C057
19 STATUS EQU $C08E
20 DATA EQU $C08F
21 PRBLNK EQU $F948
22 PRHEX EQU $FDE3
23 ↓
24 TRUFFER EQU $3000
25 IBUFFER EQU $4000
26 GRTABLE EQU $5000
27 ↓
28 SOAKTIME EQU $300
29 SLOTADR EQU $302
30 ROWSTART EQU $303
31 KEY EQU $304
32 KEYFLAG EQU $305
33 INCRMENT EQU $306
34 ↓
35 RADR EQU $06
36 DEST EQU $08
37 DEST2 EQU $1C
38 CTR EQU $19
39 YREG EQU $1B
40 TMP EQU $1E
41 COUNT EQU $1F
42 TABLE EQU $EB
43 IMAGE EQU $ED
44 KEEPPOINT EQU $F9
45 KEEPFL6 EQU $FA
46 ↓
47 TEMP1 EQU $06
48 TEMP2 EQU $07
49 TEMP3 EQU $1C
50 TEMP4 EQU $1D
51 TEMP5 EQU $1B
52 ↓
1000: 4C 09 10 53 JMP NORMPIC ;NORMAL PIC (256X64)
1003: 4C 98 10 54 JMP FULLPIC ;FULL SIZE (256X128 ENHANCED)
1006: 4C 15 11 55 JMP GREY ;GREYSCALE (16 LEVELS OF GREY)

56 ↓
57 ↓
1009: 20 34 12 58 JSR SETGR ;SET GRAPHICS ON
100C: 20 0A 12 59 JSR ACTIACLR ;FLUSH THE INPUT BUFFER
100F: A9 D3 60 LDA #$D3 ;SEND COMMAND TO SOAK W/O SEND
1011: 20 41 12 61 JSR SENDCMD ;WAIT EXPOSURE TIME
1014: 20 55 12 62 JSR SOAK ;SEND IMAGE W/O SOAK
1017: A9 C0 63 LDA #$C0 ;(ALT,WIDEPix,7BIT-256 X 64)
1019: 20 41 12 64 JSR SENDCMD ;INITIALIZE THE ROW INDEX
101C: A2 00 65 LDX #0 ;START NXT ROW, INIT COL INDEX
101E: A0 00 66 LDY #0 ;GET FIRST ROW ADDR
1020: 8D F4 13 67 LDA ROMPTR,X
1023: 18 68 CLC
1024: 6D 03 03 69 ADC ROWSTART ;0-SELECT UPPER 1/3 OF SCREEN
1027: 85 06 70 STA RADR ;$28-MID 1/3, $50-BOT 1/3
1029: E8 71 INX ;RADR HAS ADDR OF CUR ROW
102A: 8D F4 13 72 LDA ROMPTR,X
102D: 85 07 73 STA RADR+1
102F: E8 74 INX
1030: 84 1B 75 STY YREG ;POINT X-REG TO NEXT ADDRESS
1032: AC 02 03 76 LDY SLOTADR ;GET NEXT BYTE FROM CAMERA
1035: 89 8E C0 77 LDA STATUS,Y ;LOAD OFFSET TO CAMERA SLOT
1038: 4A 78 LSR ;CHECK IF NXT BYTE HAS ARRIVED
1039: 80 21 79 RCL C15 ;IF BYTE AVAILABLE THEN BRANCH
103B: A9 00 80 LDA #0 ;IF BYTE NOT AVAILABLE THEN
103D: 85 19 81 STA CTR ;SET UP TIMEOUT COUNTER
103F: A9 15 82 LDA #$15
1041: 85 1A 83 STA CTR+1
1043: C6 19 84 DEC CTR ;CHECK FOR BYTE TILL TIMED OUT
1045: D0 0F 85 BNE C1
1047: C6 1A 86 DEC CTR+1
1049: D0 0B 87 BNE C1
104B: AD 30 C0 88 LDA BEEP ;IF TIMED OUT, CLICK SPEAKER
104E: AD 00 C0 89 LDA KEYHIT ;CHECK FOR KEYPRESS
1051: 30 1D 90 BMI NDONE ;IF KEY HIT, RETURN TO BASIC
1053: 4C 0C 10 91 JMP NSTART ;ELSE, RESTART CMD SEQUENCE.
1056: 89 8E C0 92 LDA STATUS,Y
1059: 4A 93 LSR
105A: 90 E7 94 BCC C0
105C: 89 8F C0 95 LDA DATA,Y ;WHEN BYTE AVAILABLE GET IT
105F: A4 1B 96 LDY YREG ;RESTORE COL POINTER TO Y-REG
1061: C0 28 97 CPY #40 ;IF PAST 40TH BYTE IN CURRENT

```

There is no difference.



Unless you want the best price, performance and quality.

The other guys' printers have always been adequate. But why settle for adequate when you can have the best. The quiet new Riteman personal printer from Inforunner for your computer.

Made possible by over 38 years of manufacturing expertise, Inforunner has produced the best printer ever. Inch for inch, we've packed more heavy-duty quality and performance inside our compact Riteman printers at a lower cost than the competition.

Compare feature for feature. With the Riteman you get uni- or bi-directional printing running easily at 120 cps with friction, pin, and tractor feed at no extra cost. You can use your own stationery, labels, fan fold or pin feed paper. So all your printing gets done faster.

The Riteman is Epson-compatible for interfacing with most personal computers. Like

Apple and IBM. And with a wide variety of print modes including italics, super and subscripts with true descenders. So your letters and other printouts look their best.

And it runs with many popular software packages including graphics.

See for yourself how easily this incredibly low-priced printer, with the best price/performance/quality combination, fits into a briefcase — at your nearest computer dealer.

ASK YOUR DEALER or call toll free (800) 824-3044. In California (800) 421-2551. Inforunner Corporation, 1621 Stanford Street, Santa Monica, CA 90404.

Inforunner's Riteman

DISTRIBUTED WORLDWIDE

```

1063: B0 02 98          B6E C3          STA (RADR),Y          ;ROW THEN DONT PUT ON SCREEN
1065: 91 06 99          STA (RADR),Y          ;INCREMENT COLUMN POINTER
1067: C8          C3          INY #37              ;CHECK FOR END OF COLUMN
1068: C0 25 101         CPY #37              ;IF NOT, GET THE NEXT BYTE
106A: D0 C4 102         BNE GET              ;CHECK FOR END OF IMAGE
106C: E0 80 103         CPX #80              ;GOTO NEXT ROW
106E: D0 AE 104         BNE NEWROW          ;REFRESH W/O SENDING
1070: A9 D1 105         LDA #D1              ;CLEAR 'KEY HIT' VALUE
1072: 20 41 12 106     JSR SENDCMD         ;CLEAR 'KEY HIT' FLAG
1075: A9 20 107         LDA #20              ;LOOK AT KEYBOARD
1077: 8D 04 03 108     STA KEY              ;BRANCH IF NO KEYPRESS
107A: A9 00 109         LDA #0               ;CLEAR KEYBOARD STROBE
107C: 8D 05 03 110     STA KEYFLAG         ;SET 'KEY HIT' FLAG
107F: AD 00 C0 111     LDA KEYHIT          ;SAVE KEYPRESS
1082: 10 13 112         BPL D1              ;CHECK IF 'Q' HIT
1084: 2C 10 C0 113     BIT KEYCLR          ;IF NOT, RETURN
1087: EE 05 03 114     INC KEYFLAG         ;CLEAR GRAPHICS SCREEN
108A: 8D 04 03 115     STA KEY              ;SET TEXT MODE
108D: C9 D1 116         CMP #Q              ;RETURN TO BASIC
108F: D0 06 117         BNE D1              ;SET GRAPHICS ON
1091: 20 1C 12 118     JSR GRCLR          ;TAKE A PICTURE
1094: AD 51 C0 119     LDA TMODE           ;MOVE TO CORRECT BUFFER
1097: 60 120 D1 121     RTS                 ;TRANS IMAGE TO HIRTS SCREEN
1098: 20 34 12 122     FULLPIC            ;CHECK FOR KEYPRESS
1098: 20 A7 10 123     JSR TAKEPIC        ;CLEAR ACIA
109E: 20 83 12 124     JSR MOVE           ;TELL CAMERA TO SOAK W/O SEND
10A1: 20 A3 12 125     JSR DISPLAY        ;WAIT EXPOSURE TIME
10A4: 4C 75 10 126     JMP DOKEY          ;TELL CAMERA TO SEND IMAGE
10A7: 20 0A 12 128     TAKEPIC            ;(NOALT,WIDEPix,8BIT-512X128)
10AA: A9 FB 129 START   LDA #FB            ;SET UP BUFFER ADDRESS
10AC: 20 41 12 130     JSR SENDCMD        ;INIT KEEP COUNTER
10AF: 20 55 12 131     JSR SOAK           ;INCREMENT COLUMN POINTER
10B2: A9 E8 132         LDA #E8            ;CHECK IF DONE
10B4: 20 41 12 133     JSR SENDCMD        ;GET NEXT BYTE
10B7: A9 00 134         LDA #IRBUFFER      ;TELL CAMERA REFRESH W/O SEND
10B9: 85 06 135         STA RADR           ;ENHANCE IMAGE
10BB: A9 40 136         LDA #IRBUFFER      ;INIT KEEP COUNTER
10BD: 85 07 137         STA RADR+1
10BF: A9 20 138         LDA #20
10C1: 85 F9 139         STA KEEP CNT
10C3: A9 01 140         LDA #01
10C5: 85 FA 141         STA KEEP FLG
10C7: A0 00 142         LDY #0
10C9: AE 02 03 143     LDX SLOTADR        ;SETUP TIMER FOR TIMEOUT
10CC: A9 00 144         LDA #0              ;CHECK IF BYTE READY
10CE: 85 19 145         STA CTR            ;LOOP UNTIL CHAR AVAIL
10D0: 8D 8E C0 146     LDA STATUS,X       ;OR TIMED OUT
10D3: 4A 147          LSR                 ;IF TIMED OUT, CLICK & RESTART
10D4: C6 19 148         DEC CTR            ;KEEP OR DISCARD?
10D6: D0 06 149         BNE NOHANG         ;GET BYTE
10D8: AD 30 C0 150     LDA BEEP           ;STORE BYTE IN BUFFER
10DB: 4C AA 10 151     JMP START          ;GET BYTE, BUT DISCARD
10DE: 90 EC 152         RCC GSTAT          ;DECREMENT COUNTER
10E0: A5 FA 153         LDA KEEPFLG        ;INIT COUNTER
10E2: F0 08 154         BEQ IGNORE         ;TOGGLE KEEP FLAG
10E4: 8D 8F C0 155     LDA DATA,X        ;CHECK KEEP FLAG
10E7: 91 06 156         STA (RADR),Y       ;IF IGNORING, DONT INCR PNTRS
10E9: 4C EF 10 157     JMP CONT           ;INCREMENT POINTER LO
10EC: 8D 8F C0 158     LDA DATA,X        ;INCREMENT POINTER HI
10EF: C6 F9 159         DEC KEEP CNT
10F1: D0 0A 160         BNE CONT1          ;CHECK IF DONE
10F3: A9 20 161         LDA #20            ;GET NEXT BYTE
10F5: 85 F9 162         STA KEEP CNT       ;TELL CAMERA REFRESH W/O SEND
10F7: A5 FA 163         LDA KEEPFLG        ;ENHANCE IMAGE
10F9: A9 01 164         EOR #01            ;INIT KEEP FLAG
10FB: 85 FA 165         STA KEEPFLG        ;CHECK KEEP FLAG
10FD: A5 FA 166         LDA KEEPFLG        ;IF IGNORING, DONT INCR PNTRS
10FF: F0 CB 167         BEB GSTAT          ;INCREMENT POINTER LO
1101: C8 168          INY                ;INCREMENT POINTER HI
1102: D0 C8 169         BNE GSTAT          ;CHECK IF DONE
1104: E6 07 170         INC RADR+1         ;GET NEXT BYTE
1106: A5 07 171         LDA RADR+1         ;TELL CAMERA REFRESH W/O SEND
1108: C9 50 172         CMP #50            ;ENHANCE IMAGE
110A: D0 C0 173         BNE GSTAT          ;INIT KEEP FLAG
110C: A9 F9 174         LDA #F9            ;CHECK KEEP FLAG
110E: 20 41 12 175     JSR SENDCMD        ;IF IGNORING, DONT INCR PNTRS
1111: 20 F2 12 176     JSR ENHANCE        ;INCREMENT POINTER LO
1114: 60 177          RTS
1114: 60 178          RTS

```

Now your personal computer gives you a direct line to technical career opportunities.

It's free, it's confidential, it's CLEO.

- CLEO is technical help-wanted advertising that talks back. Just specify the job categories, companies, or geographic locations that interest you—CLEO calls up appropriate ads right on your screen.
- CLEO is absolutely free to the user—your only cost is the price of a phone call.
- CLEO lets you apply for technical career opportunities right from your own terminal—to employers whose advanced projects demand a state-of-the-art medium to reach the elite personnel they need.

**Access CLEO today at (415) 482-1550 (408) 294-2000
(213) 618-8800 (714) 476-8800 (619) 224-8800.**

Access assistance: (213) 618-1525

CLEO

Computer Listings of Employment Opportunities

300 BAUD, full duplex,
standard ASCII code.
An electronic publishing
activity of The
Copley Press, Inc.



Recruitment advertisers—speak through the technical market's own medium, at a price you can afford. Call (213) 618-0200 collect to find out how you can place your ad on CLEO.

Circle 84 on inquiry card.

```

1115: A9 00 179 GREY LDA #<RTABLE ;INIT TABLE POINTERS
1117: 85 EB 180 STA TABLE
1119: A9 50 181 LDA #>RTABLE
1118: 85 EC 182 STA TABLE+1
111D: A0 00 183 LDY #00
111F: 98 184 CLRI ;CLEAR GREYSCALE COUNTER TABLE
1120: 91 EB 185 STA (TABLE),Y
1122: E6 EB 186 INC TABLE
1124: D0 F9 187 RNE CLRI
1126: E6 EC 188 INC TABLE+1
1128: A9 90 189 LDA #>RTABLE+#4000
112A: C5 EC 190 CMP TABLE+1 ;CHECK FOR END
112C: D0 F1 191 RNE CLRI
112E: A9 0F 192 LDA #0F ;INIT EXPOSURE COUNTER
1130: 85 1F 193 STA COUNT
1132: A5 1F 194 NEXTPIC LDA COUNT
1134: 20 E3 FD 195 JSR PHEX ;DISPLAY COUNT FOR COUNTDOWN
1137: 20 48 F9 196 JSR PRBLNK ;LEAVE THREE SPACES
113A: 20 A7 10 197 JSR TAKEPIC ;TAKE A PICTURE
113D: A9 00 198 LDA #<RTABLE ;INIT TABLE AND BUFFER PNTRS
113F: 85 ED 199 STA IMAGE
1141: 85 EB 200 STA TABLE
1143: A9 30 201 LDA #>BUFFER
1145: 85 EE 202 STA IMAGE+1
1147: A9 50 203 LDA #>RTABLE
1149: 85 EC 204 STA TABLE+1
114B: A0 00 205 LDY #00
114D: A2 04 206 NXYTBYE LDY #04
114F: B1 ED 207 LDA (IMAGE),Y ;GET NEXT BYTE
1151: 85 1E 208 STA TMP
1153: 06 1E 209 LOADTRL ASL TMP ;TEST EACH BIT IN THE BYTE
1155: A9 00 210 LDA #00
1157: 90 02 211 BCC ZERO
1159: A9 01 212 LDA #01
115B: 06 1E 213 ZERO ASL TMP
115D: 90 03 214 BCC ZERO1
115F: 18 215 CLC
1160: 69 10 216 ADC #10
1162: 18 217 ZERO1 CLC
1163: 71 EB 218 ADC (TABLE),Y ;AND INCR APPROPRIATE CNTRS
1165: 91 EB 219 STA (TABLE),Y ;(TWO BIT-COUNTERS PER BYTE)

1167: E6 EB 220 INC TABLE ;INCREMENT TABLE POINTER
1169: D0 02 221 RNE TBL1
116B: E6 EC 222 INC TABLE+1
116D: CA 223 DEX TBL1 ;DONE WITH THIS BYTE?
116E: D0 E3 224 RNE LOADTBL ;INCREMENT BUFFER POINTER
1170: E6 ED 225 INC IMAGE
1172: D0 D9 226 RNE NXYTBYE
1174: E6 EE 227 INC IMAGE+1
1176: A9 40 228 LDA #>BUFFER+#1000
1178: C5 EE 229 CMP IMAGE+1 ;CHECK FOR END OF BUFFER
117A: D0 D1 230 RNE NXYTBYE ;IF NOT, GET NEXT BYTE
117C: 18 231 CLC
117D: AD 00 03 232 LDA SOAKTIME
1180: 6D 06 03 233 ADC INCRMENT ;INCREMENT EXPOSURE TIME FOR
1183: 8D 00 03 234 STA SOAKTIME ;NEXT EXPOSURE
1186: AD 01 03 235 LDA SOAKTIME+1
1189: 69 00 236 ADC #00
118B: 8D 01 03 237 STA SOAKTIME+1
118E: C6 1F 238 DEC COUNT
1190: D0 A0 239 RNE NEXTPIC ;DONE WITH 15 EXPOSURES?
;IF NOT, TAKE NEXT PICTURE
240 *
1192: A9 00 241 LDA #<RTABLE ;INIT TABLE AND BUFFER PNTRS
1194: 85 EB 242 STA TABLE
1196: 85 ED 243 STA IMAGE
1198: A9 50 244 LDA #>RTABLE
119A: 85 EC 245 STA TABLE+1
119C: A9 40 246 LDA #>IBUFFER
119E: 85 EE 247 STA IMAGE+1
11A0: A2 00 248 LDY #00
11A2: A9 20 249 NEXTRW LDA #20
11A4: 85 1F 250 STA COUNT ;INIT COLUMN COUNTER
11A6: A0 00 251 LDY #00
11A8: 84 1E 252 STY TMP
11AA: A9 02 253 LDA #02
11AC: 85 19 254 STA CTR ;INIT BIT COUNTER
11AE: B1 EB 255 THISBYE LDA (TABLE),Y ;GET NEXT BYTE
11B0: 29 0F 256 AND #0F ;MASK OFF TOP NIBBLE
11B2: DD E4 13 257 CMP VAL1,X ;CMP WITH DITHER MATRIX VAL
11B5: 26 1E 258 ROL TMP ;ROTATE CARRY BIT INTO BYTE
11B7: B1 EB 259 LDA (TABLE),Y ;GET BYTE AGAIN
11B9: 29 F0 260 AND #F0 ;MASK OFF LOWER NIBBLE
11BB: DD EB 13 261 CMP VAL2,X ;CMP WITH NEXT MATRIX VALUE

```

Want to hook IBM?

Terminals. Personal Computers. ASCII devices. Hook them all into the IBM world with the new AVATAR™ PA1000 Protocol Converter.

The PA1000 provides low-cost IBM 3278/2 terminal emulation and coaxial connection to an IBM 3274/3276 cluster controller. Then, a single keystroke switches you back into the asynchronous world through an auxiliary RS-232-C port to access other computer systems, public information services or copy a screen to a printer.

Our microprocessor-based unit provides user-selectable rates up to 9600 baud, terminal keyboard configura-

tions, screen management and local or remote print functions. And, you can hook the PA1000 to a modem for remote dial-in access.

Simple, economical access to the world of IBM, just when you thought there was no answer. At \$995, getting hooked has never been so affordable. For more information on our AVATAR PA1000 Protocol Converter, contact 3R Computers, 18 Lyman St., Westboro, MA 01581. Or call us at (617) 366-5300. TWX 710-390-0375.

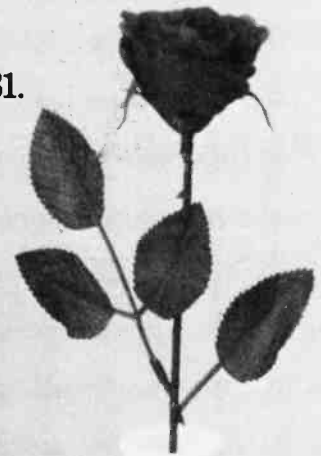

AVATAR™

Making IBM smarter since 1983.

© 1983 RRR Computers, Inc. Avatar is a trademark of RRR Computers, Inc. IBM is a registered trademark of International Business Machines Corp.

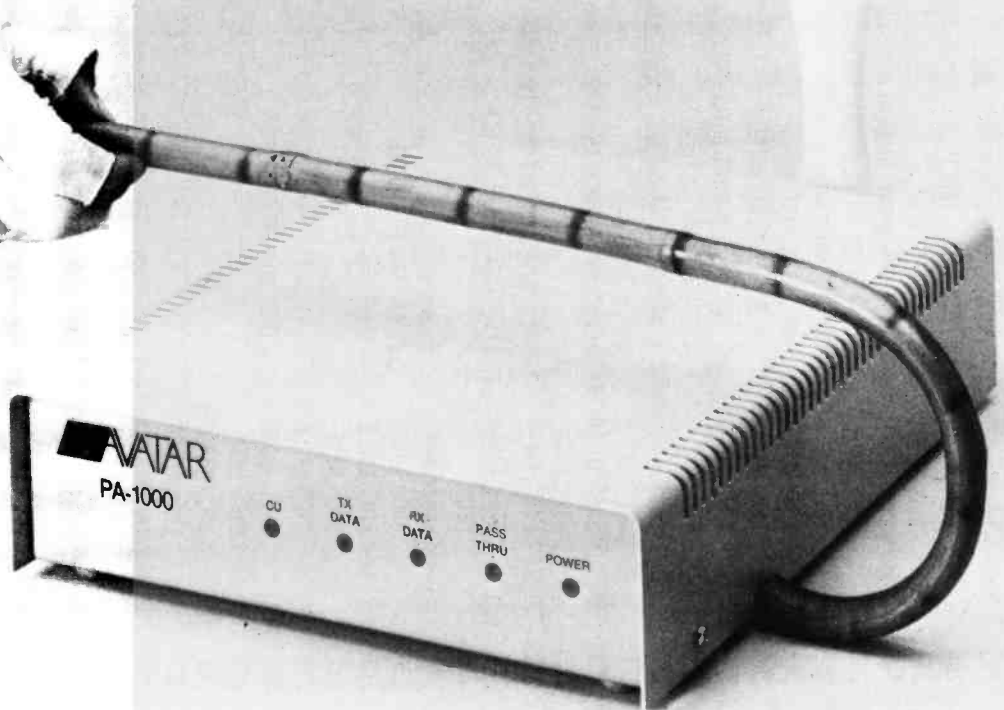



THE MICRO COMPUTER BUSINESS WILL GROW FROM \$10 TO \$100 BILLION IN THE NEXT EIGHT YEARS! ARE YOU READY TO CASH IN?

The micro computer business is predicted to grow from its present \$10 billion to \$100 billion before 1990! Imagine the possibilities this opens for you! No matter where you live, if you're starting up or presently in business, no other industry offers you more opportunities!

Now, finally, all the inside information you need to secure a prosperous future in this dynamic industry is available in one place - **THE COMPUTER ENTREPRENEUR MANUAL!** - An immense information source, compiled by our inquisitive research team, aided by a panel of experts and business people from all areas of the computer industry!

We present the inside story of more than 100 lucrative computer businesses you can enter, where you'll find the real opportunities for the eighties: from one man operations like Programming Author, Word Processing Center or Consulting, to Systems House, Service Bureau, Computer Store etc! Many at little or no investment! All the invaluable facts and figures: How to start, Capital needs, Profit estimates and Margins, How to Sell and Market, How missing technical or business experience need not stand in your way, Source of Suppliers, etc! Details that could take years to find out on your own!

We'll show you inside tricks, like how to never again pay retail for computer products and consumer electronics, even for one item - right now, while you're starting your business! How to get free merchandise and trade show invitations, etc. This alone will more than pay for the manual! You'll read actual case histories of other computer entrepreneurs, so you can learn from their mistakes, and profit from their success stories! Where you'll be one year from now depends on your actions today! Let us show you how to take the first crucial steps!

Order now and take advantage of our limited introduction special, **THE COMPUTER ENTREPRENEUR MANUAL**, and a six month subscription to **THE COMPUTER ENTREPRENEUR REPORT/NEWSLETTER** (so you're always up-to-date with the industry), both for only \$29.95! You must be convinced on how easy you can strike it rich in the micro computer business - or you may return the manual for a full refund within thirty days! **USE OUR TOLL FREE NUMBER TO ORDER!**

EVERYTHING YOU NEED TO KNOW TO SUCCEED IN THE COMPUTER BUSINESS IS ALL IN THIS MANUAL!

THE COMPUTER ENTREPRENEUR MANUAL has the answers to all your questions about selecting, starting and successfully running a computer business! There has never been such a comprehensive collection of know-how and information about this business in one place! All the facts you need to plan and achieve your goals in easy-to-follow, step-by-step instructions!

These are some of the 100-plus businesses covered in **PART ONE** of the manual, with the facts on How to start and run, Start-up Cost (Even how to operate on a shoestring), What profits to expect, Wholesale prices, Mark-ups, Suppliers, future outlook, case histories for each, etc:

Systems House, Software Author (who to sell to and who to avoid), Service Bureau, Software Publisher (How to find programs that sell, Word Processing Service, Consulting and Consultant Broker (use your skills or those of others, make \$150 - \$1000 a day!), The incredible Games Business, Computer Store (Franchises: Pro and Contra, or a low inventory store in your home!), OEM, Hardware Mfg, Data base and Teletext Service (big prospects!), Used Computers, Repairs, Rent-A-Computer, Promote Fests and Trade Shows, Turnkey Systems,

Bartering, Mail Order, Compile and rent mailing lists, Specialized Data Headhunting and Temp Help Service, Tech Writer Shop, Custom Engineering, The highly profitable Seminars and Training Business, and many more!

Many new ideas and ground floor opportunities! Interviews and success stories on companies of all sizes! Privy info on the profits made: How some computer store operators net \$100 - \$250,000! Little known outfits that made their owners millionaires, one of these low-key companies, making simple boards, went from nil to \$20,000,000 and 100 employees in four years! Programmers that make \$300,000, Thousands of micro millionaires in the making, etc!

Whatever your goal is - Silicon Valley Tycoon, or just a business at home - we guarantee you'll find a business to suit you - or your money back!

PART TWO of the manual is loaded with the know-how and "streetfighting" savvy you need, both as a novice or business veteran, to get started, to stay and prosper in the micro computer business! A goldmine of information in clear and easy-to-use instructions: How to prepare your Business Plan, Outside financing, The mistakes you must avoid, How to hire and manage employees, Incorporation (when, and how to do it cheaply), Surviving bad times, Record Keeping, how to estimate your market before you start, Use multiple locations to maximize profits, how to promote and stay steps ahead of the competition! How to get free advertising, free merchandise, free advice, Power negotiating with suppliers to double your profit margins, etc! Even how to keep a present job while starting a business part time!

Don't miss this opportunity to be part of this great industry - the next success story could be your own! Order the manual today! Part one and two, bound in a deluxe ring binder, where you can also collect our newsletter (free for six months with the manual - a \$32.50 value!) - all for only \$29.95!

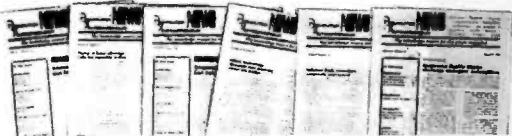

THE COMPUTER ENTREPRENEUR NEWSLETTER - ALL THE LATEST INSIDE BUSINESS NEWS! NOW! SIX MONTHS FREE WITH YOUR MANUAL!

You're always attuned to the industry, and your manual kept up-to-date, with our newsletter! Each issue has the latest business news, ideas, new suppliers, our indispensable "watchdog" column on profits, discounts (don't miss mfg's promos, like recently, when top video monitor sold at \$80 - that's half wholesale, one third of the retail price!), the competition, the big deals, etc! Feature stories with start-up info and case histories on new micro businesses!

You'll get invitations to trade shows and conventions, the usage of our advisory service and our discount buying service for your purchases!

You'll find many items in our newsletter that will save you the cost of your manual many times over!



**CALL TOLL FREE!
CHARGE IT!**
Credit Card Orders
(MC, VISA only)
accepted 24 hours/day
1-800-227-3800
Ask for extension 1135



Order by phone (Credit cards only), or use the coupon:

Mail to **THE COMPUTER ENTREPRENEUR PUBLISHING CO.**
PO BOX 456, Grand Central Station, New York, N.Y. 10163

Please send me **THE COMPUTER ENTREPRENEUR MANUAL**, and the six month free subscription to **THE COMPUTER ENTREPRENEUR REPORT/NEWSLETTER**. All for only \$29.95, plus \$3 for postage/handling (NY residents: add \$2.64 for sales tax) If I decide not to keep the manual, I may return it within 30 days for a full refund.

NAME: _____

ADDRESS: _____

CITY, STATE, ZIP: _____

Check or M.O. enclosed Charge to VISA MC

CARD# _____

Exp. Date: _____

SIGNATURE: _____

B1083

1250: AD 00 03 345	LDA SOAKTIME	STA 85 06	386	STA RADR	
125F: 85 19 346	STA CTR	12A9: A9 40	387	LDA #>IBUFFER	
1261: E6 19 347	INC CTR	12AB: 85 07	388	STA RADR+1	
1263: AD 00 03 348	LDA SOAKTIME	12AD: 8D F4 13 389	NXTROW	LDA ROMPTR, X	;GET STARTING ADDR OF CUR ROW
1266: D0 05 349	BNE SOAK1	1280: 85 08	390	STA DEST	;PUT IN SCREEN POINTER
1268: AD 01 03 350	LDA SOAKTIME+1	1282: E8	391	INX	; INCR INDEX
126B: F0 08 351	BEQ SOAK2	1283: 8D F4 13 392		LDA ROMPTR, X	;GET UPPER HALF OF ADDRESS
126D: 20 79 12 352 SOAK1	JSR MSEC	1286: 85 09	393	STA DEST+1	;PUT IN SCREEN POINTER
1270: C6 19 353	DEC CTR	1288: E8	394	INX	; INCR INDEX
1272: D0 F9 354	BNE SOAK1	1289: A0 20	395	LDY #*20	; INIT COLUMN COUNTER
1274: C6 1A 355	DEC CTR+1	128B: B1 06	396	LDA (RADR), Y	;GET BYTE FROM BUFFER
1276: D0 F5 356	BNE SOAK1	128D: 88	397	DEY	;DECR COL COUNTER
1278: 60	RTS	128E: 91 08	398	STA (DEST), Y	;PUT BYTE ON SCREEN
357 SOAK2		12C0: C0 00	399	CPY #0	;CHECK IF COUNTER IS ZERO
358 *		12C2: D0 F7	400	BNE MOV	; IF NOT, DO NEXT BYTE
1279: 84 1B 359 MSEC	STY YREG	12C4: A0 00	401	LDY #0	
127B: A0 C7 360	LDY #199	12C6: 08	402	PHP	; ROTATE EACH BYTE IN ROW SO
127D: 88 361 DLY1	DEY	12C7: 84 1E	403	STY TMP	; THE HIGH BIT IS CARRIED TO
127E: D0 FD 362	BNE DLY1	12C9: B1 08	404	LDA (DEST), Y	; THE NEXT BYTE
1280: A4 1B 363	LDY YREG	12CB: 28	405	PLP	
1282: 60	RTS	12CC: 2A	406	ROL	
365 *		12CD: 91 08	407	STA (DEST), Y	
1283: A0 00 366 MOVE	LDY #*00	12CF: 08	408	PHP	
1285: 84 ED 367	STY IMAGE	12D0: C8	409	INY	
1287: 84 08 368	STY DEST	12D1: C0 20	410	CPY #*20	
1289: A9 30 369	LDA #>IBUFFER	12D3: D0 F4	411	BNE SHFT	
128B: 85 EE 370	STA IMAGE+1	12D5: 28	412	PLP	
128D: A9 40 371	LDA #>IBUFFER	12D6: A4 1E	413	LDY TMP	
128F: 85 09 372	STA DEST+1	12D8: B1 08	414	LDA (DEST), Y	; SHIFT THE LEADING BYTE SO THE
1291: B1 ED 373 LOOP	LDA (IMAGE), Y	12DA: 4A	415	LSR	; TOP BIT IS ZERO
1293: 91 08 374	STA (DEST), Y	12DB: 91 08	416	STA (DEST), Y	
1295: C8 375	INX	12DD: C8	417	INX	
1296: D0 F9 376	BNE LOOP	12DE: C0 20	418	CPY #*20	; IF NOT DONE, ROTATE ALL OF
1298: E6 EE 377	INC IMAGE+1	12E0: D0 E4	419	BNE RESHFT	; ROW AFTER LEADING BYTE AGAIN
129A: E6 09 378	INC DEST+1	12E2: 18	420	CLC	
129C: A9 50 379	LDA #>IBUFFER+*1000	12E3: A5 06	421	LDA RADR	
129E: C5 09 380	CMP DEST+1	12E5: 69 20	422	ADC #*20	
12A0: D0 EF 381	BNE LOOP	12E7: 85 06	423	STA RADR	
12A2: 60	RTS	12E9: 90 02	424	BCC DISP1	
383 *		12EB: E6 07	425	INC RADR+1	
12A3: A2 00 384 DISPLAY	LDX #*00	12ED: E0 00	426	CPX #0	; IF SCRN NOT DONE, DO NXT ROW
12A5: A9 00 385	LDA #<IBUFFER	12EF: D0 BC	427	BNE NXTROW	

VR DATA CORPORATION ANNOUNCES: THE PRICE WAR IS OVER!!

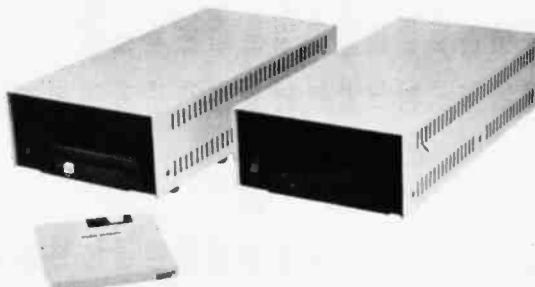
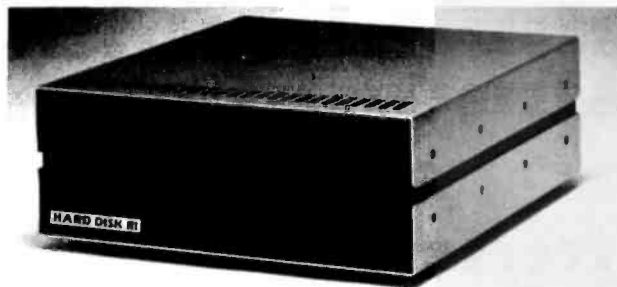

**HARD DISK III*
5 MEG
WINCHESTER** **995.**

**NEW
HD-505 WINCHESTER**

**Compact, High Density, Low Profile,
Low Power, Sub-Mini Disk System**

5+5 Meg System	1590.00	10 Meg System	1249.00
15 Meg System	1449.00	10+10 Meg System	1999.00
15+15 Meg System	2299.00		

**SAVE \$90 on 5+5 Meg
(Fixed/Removable) Package**

Packages includes:

HD-505F (Master) Fixed 5 meg	1395.00
HD-505R (Slave) Removable 5 meg	1095.00
Adaptor Module	150.00
Disk Cartridge for HD-505R	FREE!!!
TOTAL	2490.00

*Hard Disk III includes up to 2 full height Winchester disk drives, heavy duty enclosure, disk controller, field proven power supply, I/O adaptor, and applicable cabling.

*Hard Disk III is available directly from the factory only.

The NEW HD-505 Winchester Systems are available through quality Computer Stores everywhere. If yours doesn't have the HD-505 from VR DATA, tell them to get it.

MASTER unit includes: enclosure, switching power supply, disk drive, controller, host adaptor, applicable cabling.
SLAVE unit includes: enclosure, switching power supply, disk drive, applicable cabling.

**HARD DISK III & HD-505
ADAPTOR MODULES:**

IBM-XT*	IBM-PC	150.
APPLE II*	APPLE IIe*	
XEROX 820*	XEROX 820-II*	
FRANKLIN*	LNW-80	
TRS-80 MOD I	LNW-II	
TRS-80 MOD III	TRS-80 MOD 4	

OTHERS TO BE ANNOUNCED
*AVAILABLE 3RD QUARTER 1983

Call Toll Free • 800-345-8102



Published prices reflect cash discount. All prices are subject to change without notice. TRS-80 and TRSDOS are trademarks of Tandy Corp. Disk III and HD-505 are trademarks of VR DATA CORP.
8:30 am-7pm EST Mon-Fri., Sat 10am-3pm
CABLE "VRDATA" TELEX 845-124

All VR DATA products are tested, burned-in, and re-tested. We're so proud of our quality control that we offer an optional unconditional extended warranty covering full costs of parts and labor on all VR DATA products.

VRdata (215) 461-5300
777 Henderson Blvd.,
Folcroft, PA 19032

VR DATA—WEST
Watonga, OK
1-405-623-8664

```

12F1: 60      428      RTS
429 †
430 †
431 † ENHANCE REARRANGES THE IMAGE IN IBUFFER TO AN
432 † IMAGE IN IBUFFER THAT CORRESPONDS MORE
433 † PRECISELY TO THE ACTUAL PICTURE BEING SEEN
434 † BY THE CAMERA.
435 † THE ALGORITHM REARRANGES EACH BYTE AS FOLLOWS:
436 † FOR BYTES IN EVEN ROWS(STARTING WITH ROW 0) --
437 † BITS 2 AND 6 ARE UNCHANGED
438 † BIT 0 MOVES TO BIT 3 OF THE BYTE 1 NEXT ROW
439 † BIT 4 MOVES TO BIT 7 OF THE BYTE 1 NEXT ROW
440 †
441 † FOR BYTES IN ODD ROWS --
442 † BITS 0 AND 4 ARE UNCHANGED
443 † BIT 2 MOVES TO BIT 5 OF THIS BYTE IN NEXT ROW
444 † BIT 6 MOVES TO BIT 1 OF THIS BYTE+1 IN NEXT ROW
445 †
446 †
12F2: A9 DF      447 ENHANCE LDA #<IBUFFER-$21 ; INIT BUFFER POINTERS
12F4: 85 06      448 STA RADR
12F6: 85 08      449 STA DEST
12F8: A9 3F      450 LDA #>IBUFFER-$21
12FA: 85 07      451 STA RADR+1
12FC: A9 2F      452 LDA #>IBUFFER-$21
12FE: 85 09      453 STA DEST+1
1300: A9 20      454 LDA #20
1302: 85 1E      455 STA TMP
1304: A0 01      456 NEVEN LDA #1 ; PERFORM OPERATION AS DESCR
1306: B1 06      457 LDA (RADR),Y ; ABOVE ON EVEN ROWS
1308: 0A          458 ASL
1309: 0A          459 ASL
130A: 0A          460 ASL
130B: 09 DF      461 ORA #0DF
130D: 85 1C      462 STA DEST2
130F: 88          463 DEY
1310: B1 06      464 LDA (RADR),Y
1312: 2A          465 ROL
1313: 2A          466 ROL
1314: 2A          467 ROL
1315: 09 FD      468 ORA #FD
1317: 85 1D      469 STA DEST2+1
1319: A0 21      470 LDA #21
131B: B1 06      471 LDA (RADR),Y
131D: 09 8B      472 ORA #8B
131F: 29 FF      473 AND #FF
1321: 25 1C      474 AND DEST2
1323: 25 1D      475 AND DEST2+1
1325: 91 08      476 STA (DEST),Y
1327: E6 06      477 INC RADR
1329: E6 08      478 INC DEST
132B: D0 04      479 BNE NODUB
132D: E6 07      480 INC RADR+1
132F: E6 09      481 INC DEST+1
1331: C6 1E      482 DEC TMP
1333: D0 CF      483 BNE NEVEN
1335: A9 20      484 LDA #20
1337: 85 1E      485 STA TMP
1339: A0 01      486 NOOD LDA #1 ; PERFORM OPERATIONS AS DESCR
133B: B1 06      487 LDA (RADR),Y ; ABOVE ON ODD ROWS
133D: 0A          488 ASL
133E: 0A          489 ASL
133F: 0A          490 ASL
1340: 09 77      491 ORA #77
1342: 85 1C      492 STA DEST2
1344: A0 21      493 LDA #21
1346: B1 06      494 LDA (RADR),Y
1348: 09 EE      495 ORA #EE
134A: 29 FF      496 AND #FF
134C: 25 1C      497 AND DEST2
134E: 91 08      498 STA (DEST),Y
1350: E6 06      499 INC RADR
1352: E6 08      500 INC DEST
1354: D0 04      501 BNE NODUB2
1356: E6 07      502 INC RADR+1
1358: E6 09      503 INC DEST+1
135A: C6 1E      504 DEC TMP
135C: D0 DB      505 BNE NODD
135E: A9 20      506 LDA #20
1360: 85 1E      507 STA TMP
1362: A5 08      508 LDA DEST
1364: C9 DF      509 CMP #<IBUFFER+$FDF ; CHECK FOR END OF BUFFER
1366: D0 09      510 BNE NEVENJ
1368: A5 09      511 LDA DEST+1
136A: C9 3F      512 CMP #>IBUFFER+$FDF

```

It's Simple. . . **CALL AND SAVE MONEY**

1-800-841-0860

**CONVENIENT
ORDER ENTRY
GA. INFO. 912-377-7120**

"Telemarketing Works For You"

FRANKLIN
ACE 1000 COMPUTER
ACE 1200 COMPUTER
FROM **\$CALL**

Commodore
COMPUTERS
MONITORS, PRINTERS & DRIVES
FROM **\$CALL**

TRS-80 COMPUTERS



**PURE
RADIO SHACK
EQUIPMENT**

**DISCOUNT
PRICED
FROM**
MODEL 4 TRS-80.....'809
MODEL 12 TRS-80.....'2639
MODEL 16 TRS-80.....'3998
MODEL 100 TRS-80.....'677
MC-10 TRS-80.....'99
COLOR COMPUTER....'CALL
WE SELL THE COMPLETE LINE
OF TRS-80 COMPUTERS
AND ACCESSORIES

**IBM COMPATIBLES
YOUR CHOICE**
EAGLE PC
COLUMBIA PC
CORONA PC
\$CALL

Hayes®
MODEMS
FROM **\$239**
MICRO MODEM I
SMART MODEM 300
SMART MODEM 1200



MICRO COLOR
\$99

**TRS-80
COMPUTERS**



MODEL 100
FROM **\$677**



MODEMS
FROM **\$119**
•J-CAT •D-CAT
•CAT •AUTO CAT
•SMART CAT •APPLE CAT

**EPSON
PRINTERS**
FROM **\$CALL**

FX-80.....**SAVE**
RX-80.....**SAVE**
FX-100.....**SAVE**

TRS-80 PRINTERS
COMPLETE LINE FROM **\$199**



**TP-I DAISY
WHEEL
PRINTER**
FROM **\$CALL**



PRINTERS
FROM **\$309**
GEMINI
10X & 15



PROWRITER
8510.....'339
NEW!
8600.....'CALL

**OKIDATA
PRINTERS**

FROM **\$CALL**
MICROLINE SERIES
•83A
•84P •92P •93P
PACEMARK 2350P

DATA FLEX
APPLICATIONS
DATA BASE
BY DATA ACCESS
\$CALL

COMREX
AMDEK
\$CALL

NOTICE

ALL PRODUCTS WE SELL ARE BRAND NEW AND COVERED BY THE MANUFACTURER'S SPECIFIC WARRANTIES. COPIES AVAILABLE UPON REQUEST. WE DO NOT SELL ANY USED, RECONDITIONED, FOREIGN OR INFERIOR MODIFIED EQUIPMENT. PRICES AND PRODUCTS SUBJECT TO CHANGE WITHOUT NOTICE.

**PRINTER
CARDS
AND CABLES
GRAPPLER+**



**QUADRAM
CORPORATION**
•IBM BOARDS
•MICROFAZERS
•APPLE BOARDS
\$CALL

FREE

UPON REQUEST
•DISCOUNT PRICE LIST &
INFORMATION KIT
WRITE
MICRO MANAGEMENT SYSTEMS
TELEMARKET DEPT. # 1

**NEW
PRODUCTS
\$CALL**

**Verbatim
DATA LIFE
DISKETTES
\$CALL**

Since 1978

- REPUTATION BACKED BY YEARS OF EXPERIENCE.
- PIONEER IN DIRECT TO CONSUMER SALES OF MICRO COMPUTERS AND ELECTRONICS
- MILLIONS OF DOLLARS IN SALES OVER THE YEARS
- TENS OF THOUSANDS OF CUSTOMERS
- HONEST
- RELIABLE
- LARGE INVENTORY
- NAME BRAND PRODUCTS



Man's Best Friend
**Micro Management
Systems, Inc.**

2803 Thomasville Road East
Cairo, Georgia 31728
(912) 377-7120

**DISCOUNT
PRICES**



**BUY
DIRECT**

TELEMARKET DEPT. 1

```

136C: D0 03 513      BNE NEVENJ
136E: 4C 74 13 514    JMP FILLIN
1371: 4C 04 13 515    NEVENJ JMP NEVEN ;LOOP IF NOT DONE
516  †
517 †*****
518 † FILLIN COLORS HOLES IN THE IMAGE IN TBUFFER
519 † EITHER BLACK OR WHITE, DEPENDING ON THE COLORS
520 † OF THE SURROUNDING PIXELS.
521 † THE ALGORITHM USED IS AS FOLLOWS:
522 † FOR BYTES IN EVEN ROWS (STARTING WITH ROW 0)---
523 † BITS 0,3,4,7 ARE 'HOLES'
524 † BITS 2 AND 6 ARE UNCHANGED
525 † BIT 5 COMES FROM BIT 2 OF THE BYTE 1 ROW PREV
526 † BIT 1 COMES FROM BIT 6 OF THE BYTE 1 ROW
527 † PREVIOUS LESS ONE BYTE
528 †
529 † FOR BYTES IN ODD ROWS---
530 † BITS 1,2,5,6 ARE 'HOLES
531 † BITS 0 AND 4 ARE UNCHANGED
532 † BITS 3 AND 7 COME FROM BITS 0 AND 4 OF THE
533 † BYTE 1 ROW PREVIOUS
534 †*****
535 †
1374: A9 E0          FILLIN LDA #<TBUFFER-$20 ;INIT BUFFER POINTER
1376: 85 08          STA .DEST
1378: A9 2F          LDA #>TBUFFER-$20
137A: 85 09          STA DEST+1
137C: A2 00          LDX #0
137E: A9 20          LDA #&20
1380: 85 1E          STA TMP
1382: A0 00          LDY #0 ;FILLIN EACH ROW AS
1384: B1 08          LDA (DEST),Y ;DESCRIBED ABOVE
1386: 85 07          STA TEMP2
1388: A0 40          LDY #&40
138A: B1 08          LDA (DEST),Y
138C: 85 1C          STA TEMP3
138E: 25 07          AND TEMP2
1390: 85 06          STA TEMP1
1392: A0 20          LDY #&20
1394: B1 08          LDA (DEST),Y
1396: 4A             LSR
1397: 1D E0 13 554    ORA RMASK,X

```

```

139A: 05 06          555 ORA TEMP1
139C: 85 1D          556 STA TEMP4
139E: B1 08          557 LDA (DEST),Y
13A0: 0A           558 ASL
13A1: 1D E2 13 559    ORA LMASK,X
13A4: 05 06          560 ORA TEMP1
13A6: 85 1B          561 STA TEMPS
13A8: A5 07          562 LDA TEMP2
13AA: 05 1C          563 ORA TEMP3
13AC: 1D DE 13 564    ORA CMASK,X
13AF: 31 08          565 AND (DEST),Y
13B1: 25 1D          566 AND TEMP4
13B3: 25 1B          567 AND TEMPS
13B5: 91 08          568 STA (DEST),Y
13B7: E6 08          569 INC DEST
13B9: D0 08          570 BNE FILL2
13BB: E6 09          571 INC DEST+1
13BD: A9 40          572 LDA #>TBUFFER+$1000
13BF: C5 09          573 CMP DEST+1 ;CHECK FOR END OF BUFFER
13C1: F0 0F          574 BEQ FILL3
13C3: C6 1E          575 DEC TMP
13C5: D0 BB          576 BNE FILL1
13C7: A9 20          577 LDA #&20
13C9: 85 1E          578 STA TMP
13CB: 8A           579 TXA
13CC: A9 01          580 EOR #1
13CE: AA           581 TAX
13CF: 4C 82 13 582    JMP FILL1
13D2: A2 1F          583 LDX #&1F
13D4: 8D 40 30 584    LDA TBUFFER+$40,X ;CLEAN UP THE FIRST ROW
13D7: 9D 00 30 585    STA TBUFFER,X
13DA: CA           586 DEX
13DB: 10 F7          587 BPL CLEAN
13DD: 60           588 RTS
589 †
13DE: 66 99          590 CHASK
13E0: EE 8B          591 RMASK
13E2: 77 DD          592 LMASK
13E4: 01 0D 04       593 VAL1
13E7: 0F           594 VAL2
13E8: 90 50 C0       595 VAL2
13EB: 80           596 VAL2

```

COHERENT™ IS SUPERIOR TO UNIX* AND IT'S AVAILABLE TODAY ON THE IBM PC.

Mark Williams Company hasn't just taken a mini-computer operating system, like UNIX, and ported it to the PC. We wrote COHERENT ourselves. We were able to bring UNIX capability to the PC with the PC in mind, making it the most efficient personal computer work station available at an unbelievable price.

For the first time you get a multi-user, multitasking operating system on your IBM PC. Because COHERENT is UNIX-compatible, UNIX software will run on the PC under COHERENT.

The software system includes a C-compiler and over 100 utilities, all for \$500. Similar environments cost thousands more.

COHERENT on the IBM PC requires a hard disk and 256K memory. It's available on the IBM XT, and Tecmar, Davong and Corvus hard disks.

Available now. For additional information, call or write,

Mark Williams Company
1430 West Wrightwood, Chicago, Illinois 60614
312/472-6659



COHERENT is a trademark of Mark Williams Company.
*UNIX is a trademark of Bell Laboratories.

Circle 511 on Inquiry card.

Never again worry about computer theft or damage

What could be better than full replacement?

By now, you've probably heard or read about SAFEWARESM Insurance for microcomputers. But you may still wonder just what it protects, or whether it's really worth the investment. If you've never lost any part of your computer system or software, you probably don't yet realize the limitations of most standard insurance coverages. Or the agonies you could face in trying to recover even the simplest piece of peripheral equipment.

What do you mean it's not covered?!

Operating your computer system without SAFEWARE protection is fine as long as you don't have to worry about an accident or loss. But what if you came home one night to discover you'd been robbed? Or that a pipe had burst and caused water damage? Or that your system, too, had fallen victim to a leading destroyer of microsystems—a power surge? All events beyond your control. If something like this should happen to you, you're likely to find out the hard way just how limited your standard insurance policy's protection really is. And no matter how little or how much you have invested in your computer system, discovering that it's not covered can be an expensive lesson.

Now you can be sure

SAFEWARE was developed by an insurance professional who was shocked to learn that his very own personal computer was at risk. Can you imagine? What he discovered was that his homeowners insurance policy excluded coverage as soon as he began operating his first business program. Even his simplest spreadsheet voided coverage. Because most homeowners policies *won't cover any equipment used for business*, no matter how infrequently. Out of this need was born SAFEWARE. A simple, easy-to-understand coverage you can count on. Full replacement coverage of hardware, software and media, after a low \$50 deductible.

With SAFEWARE there's no need for you to schedule equipment or software as you do with the "rider" type of policies. So your coverage can grow with your system, providing protection for its full value rather than each individual item. This will be especially important to you if you're ever planning



to buy additional equipment or software. Even just one peripheral.

What the editors are saying

Desktop Computing: . . . "Given the amount of money that business users spend on computer equipment . . . it's not too farfetched to say that an insurance policy may be the most important new accessory that you could add to your desktop computer system."

Computer Decisions: . . . "Your personal computer might not be safe at home. If it is not insured, then you're running the risk of losing the thousands of dollars you've invested . . ."

Personal Computing: . . . "Replacing hardware may be more of a problem than you thought it would be . . . That's why (a computer consultant) suggests that you get the computer insured."

Wall Street Journal: . . . "Columbia National General Agency introduces a policy that covers home computers regardless of use. The usual premium: about \$75 a year."

An All-Risk, no risk offer

SAFEWARE is an *All-Risk* plan of insurance, which means that it covers *all* hardware, *all* purchased software, and *all* media. Your complete system is protected against theft, fire, accidental damage, even

damage sustained while the computer is being transported in your car. SAFEWARE even covers damage caused by power surges . . . the leading destroyer of microcomputers. And, now, SAFEWARE is available on a *no risk* basis. If you are not completely satisfied with the protection afforded by SAFEWARE, you may return the policy for a full refund within the first 10 days after you've received it.

Thousands have said "yes!"

Since it was first introduced in 1982, thousands of computer owners, like you, have said "yes" to the SAFEWARE offer. Owners of systems from the smallest portable micros to larger sophisticated business systems are finding that SAFEWARE offers the most affordable and complete security. And the simplest peace of mind available to ensure carefree computing.

The cost: pennies a day

As you can see from the table, the annual premium for a typical system consisting of a \$3,000 processor, a disk drive and printer worth \$1,100, and \$900 in software, is just \$60. And you can save even more since the cost of insurance for personal computers used for business may be tax deductible. To determine your rate of coverage, just add

up your total system value. Then, find the premium in the table.

Easy to order

Choose from three simple ways to pay for your complete SAFEWARE protection: Call the toll free phone number listed and we'll charge your premium to your VISA or MasterCard. Or, you can mail us your order along with your check. Or, send us the coupon and charge your policy to your credit card.

Total Hardware, Media & Software System Value	Annual Premium
Up to \$ 2,000	\$ 35
\$ 2,001-\$ 5,000	\$ 60
\$ 5,001-\$ 8,000	\$ 75
\$ 8,001-\$11,000	\$ 90
\$11,001-\$14,000	\$105
\$14,001-\$17,000	\$125
\$17,001-\$21,000	\$140
\$21,001-\$24,000	\$155
\$24,001-\$27,000	\$170

Call toll free for rates on higher coverages
Not available in DC, HI, KY, LA, ME, MS, NV, SC, WY

800-848-3469

(In Ohio call 800-848-2112)
Phones open 8 a.m. to 8 p.m.
Monday through Saturday



Columbia National General Agency
88 E. Broad Street, Columbus,
OH 43215

With SAFEWARE you get . . .

- Full replacement coverage.
- Freedom from worries of fire, theft or accident.
- Ultimate in power surge protection.
- Costs as low as \$35 a year.

Yes, my computer needs immediate protection.
Please issue my SAFEWARE Insurance Policy.

Name _____

Street _____

City _____

State _____ Zip _____

System value \$ _____

Check Enclosed VISA

MasterCard

Card # _____

Exp. Date _____

No risk. You may return policy for full refund within 10 days. Coverages and limits are subject to the terms, conditions and exclusions in the policy.

Mail to: SAFEWARE, P.O. Box 02211,
BYT Columbus, OH 43202

Listing 2b continued:

```

14CA: A8 2E AB
14CD: 32 A8 36
14D0: A8 3A AB
14D3: 3E 612
14D4: 28 23 28
14D7: 27 28 28
14DA: 28 2F 28
14DD: 33 28 37
14E0: 28 3B 28
14E3: 3F 613
14E4: A8 23 AB
14E7: 27 A8 28
14EA: A8 2F AB
14ED: 33 A8 37
14F0: A8 3B AB
14F3: 3F 614

```

--END ASSEMBLY--

ERRORS: 0

1268 BYTES

SYMBOL TABLE - ALPHABETICAL ORDER:

```

ACIACL = $120A    BEEP = $C030    C1 = $1043    C1 = $1056
C15 = $105C       C3 = $1067    CLR1 = $13D4    CLR1 = $111F
CLR2 = $1227      CMASK = $13DE    CONT = $10EF    CONT1 = $10FD
COUNT = $1F      CTR = $19      D1 = $1097      DATA = $C08F
DEST = $08        DLY1 = $127D   D1SP1 = $12ED   DISPLAY = $12A3
DLY1 = $127D     DLY2 = $1075   DLY3 = $13C3    DLY4 = $12F2
FILL1 = $1382    FILL2 = $1030    FILL3 = $13D2    FILLIN = $1374
FULLPIC = $1098  GET = $1030     GNODE = $C050    GSTAT = $10CC
GREY = $1115     GRTABLE = $5000    IGNORE = $10EC   IMAGE = $ED
IBUFFER = $4000  IKEYPFLG = $FA    KEY = $0304     KEYCLR = $C010
KEEPCNT = $F9    KEYHIT = $C000   LMASK = $13E2    LOADTBL = $1153
KEYFLAG = $0305    MIXED = $C053    MOVE = $128B    MOVE = $1283
LOOP = $1291     MSEC = $1279   NDONE = $1070   NEVEN = $1304
MSEC = $1279     NEXT = $11E9   NEXTPIC = $1132    NEXTROM = $11A2
NEURW = $101E    NODD = $1339   NODUB = $1331    NODUB2 = $135A
NODD = $1339     NDRMPC = $1009    NXT1 = $1331    NXT2 = $1200
NDRMPC = $1009   PRHEX = $FDE3    NXT2 = $11F5

```

```

NXTBYTE = $114D   NXTROW = $12AD   PAGE1 = $C054   PRBLNK = $F94B
PRHEX = $FDE3    RADR = $06       RESHFT = $12C6   RMASK = $13E0
ROMPTR = $13F4   ROWSTART = $0303    SEND1 = $1247   SENDCMD = $1241
SETGR = $1234    SHFT = $12C9     SLOTADR = $0302  SOAK = $1255
SOAK1 = $126D   SOAK2 = $1278    SOAKTIME = $0300  START = $10AA
STATUS = $C08E   TABLE = $EB     TAKEPIC = $10A7  TBL1 = $116D
TBUFFER = $3000  TEMP1 = $06      TEMP2 = $07     TEMP3 = $1C
TEMP4 = $1D      TEMP5 = $1R      THISBYT = $11AE  THISROM = $11A6
TMODE = $C051   TMP = $1E        VAL1 = $13E4    VAL2 = $13EB
VAL3 = $13EC    VAL4 = $13F0     YREG = $1B      ZERO = $115B
ZERO1 = $1162

```

SYMBOL TABLE - NUMERICAL ORDER:

```

RADR = $06        TEMP1 = $06      TEMP2 = $07     DEST = $08
CTR = $19         YREG = $18       TEMPS = $18     DEST2 = $1C
TEMP3 = $1C       TEMP4 = $1D      TMP = $1E        COUNT = $1F
TABLE = $EB       IMAGE = $ED      KEEP CNT = $F9   KEEPFLG = $FA
SOAKTIME = $0300  SLOTADR = $0302  ROMSTART = $0303  KEY = $0304
KEYFLAG = $0305  INCRMENT = $0306  NDRMPC = $1009  NSTART = $100C
NEURW = $101E    GET = $1030      CO = $1043       CI = $1056
C15 = $105C       C3 = $1067       NDONE = $1070   DOKEY = $1075
D1 = $1097        FULLPIC = $1098  TAKEPIC = $10A7  START = $10AA
GSTAT = $10CC    NOHANG = $10DE   IGNORE = $10EC   CONT = $10EF
CONT1 = $10FD    GREY = $1115     CLR1 = $111F     NEXTPIC = $1132
NXTBYTE = $114D  LOADTBL = $1153  ZERO = $115B     ZERO1 = $1162
TBL1 = $116D     NEXTRW = $11A2  THISROM = $11AE  THISBYT = $11AE
NEXT = $11E9     NXT1 = $11F5     NXT2 = $1200     DONE = $1203
ACIACL = $120A   GRCLR = $121C    CLR2 = $1227     SETGR = $1234
SENDCMD = $1241  SEND1 = $1247    SOAK = $1255     SOAK1 = $126D
SOAK2 = $1278   MSEC = $1279     DLY1 = $127D     MOVE = $1283
LOOP = $1291     DISPLAY = $12A3  NEXTRW = $12AD   MOV = $128B
RESHFT = $12C6  SHFT = $12C9     D1SP1 = $12ED    ENHANCE = $12F2
NEVEN = $1304   NODD = $1331     NODD = $1339     MODDUB2 = $135A
NEVENJ = $1371  FILLIN = $1374   FILL1 = $1382    FILL2 = $13C3
FILL3 = $13D2   CLEAN = $13D4    CMASK = $13DE    VAL3 = $13EC
LMASK = $13E2   VAL1 = $13E4     VAL2 = $13E8     VAL3 = $13EC
VAL4 = $13F0    ROMPTR = $13F4   TBUFFER = $3000  IBUFFER = $4000
GRTABLE = $5000  KEYHIT = $C000   KEYCLR = $C010   BEEP = $C030
SHODE = $C050   TMODE = $C051   TMIXED = $C053  PAGE1 = $C054
HGR = $C057     STATUS = $C08E  DATA = $C08F   PRBLNK = $F94B
PRHEX = $FDE3

```



The personal, portable daisywheel printer.

Only \$599.

For the first time, your letter-quality printer can be used almost anywhere! Bring the new Transtar 120 with you to work, to school, and home again! Conveniently weighing in at less than 19 pounds, it generates unrivaled print quality and is the size of a standard briefcase. The new 120 is so light, so small, that you can take it with you!

Remarkably, the new \$599 Transtar 120 is "plug and go" compatible with the best-selling word processing programs. Just plug the 120 into your personal computer and watch this precision printer purr along at 14 cps Shannon text speed producing superscript, subscript, underlining and a true boldface. Even using letterhead is now a breeze with the 120's automatic single sheet loading!

Don't worry about durability: it's a tough little machine. It joins the highly reliable family of Transtar printers with a failure rate that's the envy of the industry: less than 1%. Should your 120 ever need repair, a nationwide network of authorized service centers stands ready for speedy repair on your six-month end-user warranty.

Just think of it: everything you want in a letter-quality printer...anywhere you want it. Only \$599.

Transtar

P.O. Box C-96975, Bellevue, Washington 98009

Circle 481 on inquiry card.

User to User

Conducted by Jerry Pournelle

Copy Protection and Privacy

Dear Jerry,

The Superscribe II word processor is distributed by On-Line Systems (now Sierra On-Line Inc.). When I first got it, I found it a fairly good word processor with some very interesting features. For instance, it has a 70-column upper/lower-case display on an unmodified Apple with *software* printer spooling and a keyboard buffer. Not a bad achievement, even with its share of bugs. And On-Line did provide a free backup disk.

Then, last summer, On-Line updated the program to its present Screenwriter II and gave it some enhancements, such as a mouse or joystick. However, it also added a *very* nasty copy-protection system. The company's update policy was \$10 for a new disk and a manual with the return of one of the disks. After about two weeks, I got the new disk and manual (a large improvement, I might add). It wouldn't boot, so I took it to a store owned by a friend of mine and tried to boot it on a Franklin with Apple drives, an Apple with Rana drives, and an Apple with a Super-5 and a normal drive. It would not boot on any of them. So off went the disk to the company, and two weeks later I got a new one. It wouldn't boot on any of the machines, either. I called, and the company said to return it again. Being an accomplished programmer, I decided to play around for a while. After spending a few minutes boot-tracing the program, I finally got it to run. However, I simply am not going to boot-trace a program every time I want to run it, which in this case might be two or three times a day. So I found the nibble counts in it and removed them. It then worked on any machine. When I called the company and told a programmer there how to fix this problem, he said (in a very moronic tone), "Oh, uh, I guess we'll fix it" and took my name and address. About three weeks later I started to receive *Softalk* magazines free, with a little "Sponsored by On-Line Systems" on top of the label. Not exactly the correction I had hoped for.

I simply cannot abide by a tool being protected from copying, or in this case just *use*. As a result of the company's screwing around, I lost four weeks of

valuable time owing to the loss of the backup. It is absolutely ridiculous to keep someone who relies on a product from copying it. Beyond that, if I wanted to modify it for either of my nonstandard drive configurations, I couldn't because the nibble counts would stop it from functioning; the length and content would be changed.

It is simply not worth buying a product that I can't use to my own ends, provided I don't pirate it, which I wouldn't. It is also interesting to note that a product I subsequently purchased from On-Line (the game *Pest Patrol*) would not work on my drives, which I had completely checked by a Class I repair center. In light of this, I have decided never to purchase anything from On-Line again and advise anyone who wants products guaranteed to *work* on their Apple system to do likewise.

Douglas Henkin
150 East 77th St.
New York, NY 10021

My late mad friend would have published the company's bit map in retaliation. Companies that destroy their own utility to "prevent piracy" only encourage legitimate hackers to turn pirate. . . . Jerry

Dear Jerry,

In your June column ("Zenith Z-100, Epson QX-10, Software Licensing, and the Software Piracy Problem," page 411) you touched on a subject near and dear to my heart, protection. I have three words to say about it: I hate it. I have no objection to copyright; just those protection schemes.

My problems started when I bought a 5-megabyte Corvus hard disk for my Apple IIe. The Corvus drive can only live in slot 6 because of the firmware on the controller card; therefore, the floppy disk must be elsewhere. The first problem I ran into was not being able to put my games, educational and other protected software on the Corvus. The second problem was booting protected software from the floppy disk in slot 7 or elsewhere. Do you realize how much software out there will not work if the floppy-disk controller is not in slot 6? I said to myself, instead of trying to get all soft-

ware houses in the universe to change their software, why not get Corvus to change its firmware so that it can go in slot 7? Well, after having my dealer call Corvus several times, the company's answer was, "impossible to do." I tried to call the vice-president of the company and never got a return call. High Technology software of Oklahoma City also talked to them. No way, they said.

Back to protection. CP/M software is not protected, and I don't hear them crying about pirates of their software. Beagle Bros. Software is not protected and it is still in business. At least one well-known game house has dropped protection and reduced all of its prices on software for the Apple to \$19.95.

Like you said, "For every protection scheme there is somebody out there ready to break it." How can it be stopped? Software programmers, please stop putting those locks on your software. Instead, install a serial number somewhere in the program that is registered to the original owner. That way, if he sells or gives away a copy and the person who gets it needs to send it back to the company for any reason, the serial number can be traced. Finally, have faith and enforce your copyrights. Yes, believe it or not, I think the majority of people out here have integrity and are not out to rip you off.

Stan Epstein
116 S. Cedarwood
Rose Hill, KS 67133

Piracy is a real problem, but most protection schemes cause far more problems than they solve. . . . Jerry

What's the Cache?

Dear Jerry,

In your July column ("Interstellar Drives, Osborne Accessories, DEDICATE/32, and Death Valley, page 323), you used the word "cache" to refer to a system that stores frequently used information from a disk in RAM. I thought you might like some background information. I understand that the original use of the word cache in computers had to do with mainframe computers. A mainframe will have a large main memory (say 256K bytes)



Suddenly, personal computers that just stand alone don't stand a chance.



The trouble with most personal computers is that they don't tie into office automation. Maybe that's why they're called "standalones". So instead of bringing the people in your company together, they only succeed in keeping them apart.

But one personal computer is different: the Wang Professional Computer.

In fact, it's the one personal computer that can really tie into total office automation.

Not only does it work together with every other piece of Wang equipment, it can also communicate with most mainframes.

So everyone in your company has immediate access to the exact information they need. In the exact format they need it in: words, numbers and images.

What's more, you also get Wang word processing, the easiest-to-use word processing in the world.

Why risk standing alone with other personal computers when Wang puts it all together so well.



For a demonstration of The Wang Professional Computer, call **1-800-225-9264**. Or send this coupon to: Wang Laboratories, Inc., Business Executive Center, One Industrial Avenue, Lowell, MA 01851.

Name	_____		
Title	_____		
Company	_____		
Address	_____		
City	State	Zip	_____
Telephone	_____		BY1



**The Office Automation
Computer People.**

with access times around 200 to 500 nanoseconds. That's fast enough to keep most microcomputer CPUs happy, but it seems like a long time to a mainframe CPU. So a small amount (say 256K bytes) of fast, expensive cache memory is installed between the CPU and the main memory to hold the frequently used information from the main memory. The access time of the cache memory might be 20 to 50 nanoseconds.

My opinion, for what it's worth, is that disk emulators (or RAM disks) will gradually become obsolete. The 16-bit microcomputers on the market can handle up to about 500K bytes of addressable memory, which is more than you can put on a 5¼-inch disk. Once enough software becomes available to take advantage of all that memory, disk emulators will no longer be needed.

Gerry Ashton
Box 415, Rural Rt. 4
Hopewell Jct., NY 12533

Thanks. Tracy Kidder explains cache well in his The Soul of a New Machine. You're probably right about disk emulators, but not for a while. They'll last a couple more years, and wow, do they save time! . . . Jerry

Public Key Encryption

Dear Jerry,

Computer systems security is part of my job here at Kodak Park. Therefore, I was quite interested in your comments on public key crypto systems in your July column ("Interstellar Drives, Osborne Accessories, DEDICATE/32, and Death Valley," page 323).

I would really like to know whether anyone succeeds in deciphering the file you published that was generated by DEDICATE/32.

William E. Florance
Security Administrator
Eastman Kodak Co.
Management Services Division
Bldg. 56, Kodak Park
1669 Lake Ave.
Rochester, NY 14650

So far no one has claimed the prize! In fact, only a few admit to having tried. . . . Jerry

Dear Jerry,

You hit the nail on the head, sir. The most common mistake I've seen made

about encryption schemes is boundless faith in long keys. Although key length is important, it only gives one a rough feel for the resistance of a particular cipher to brute force (i.e., try every key) attacks. A mathematically weak system can be attacked with several analytical tools, assuming the enciphering process is public knowledge. If it isn't, the use of classic cryptanalytic attack (cribs, etc.) will be the approach of choice.

Incidentally, I seem to recall an article in *Infoworld* late last year that described the successful breaching of the public key system by a mathematician using an Apple II. As I remember, the demonstration was at some kind of convention and (seemingly) was tightly controlled. I wouldn't use the public key system to hide a second set of books, anyhow.

The bottom line is, any cryptosystem is of only hypothetical security value, and some hypotheses are better than others. The major concern I would have in evaluating the merits of any encryption scheme is the sophistication of the opposition and the volume of material to be encrypted. Several old and simple systems are quite secure for enciphering limited amounts of plain text, notably the Playfair cipher and the Jefferson wheel (AKA the Bazeries cylinder). These systems are very easy to implement on the micro and can be worked by hand if need be. The same can hardly be said for the [National Bureau of Standards] Data Encryption Standard, eh?

Another generally held rule of thumb is that the security of a system cannot be based on the secrecy of the encryption process, be it by mechanical device or computer program. The opposition should be presumed to have everything you have, save the key.

If you're interested in further information, I highly recommend David Kahn's excellent book, *The Codebreakers*, a classic in the field of cryptology.

Bob Scott, Lieutenant, U.S. Navy
3095 Marina Dr., Unit -2
Marina, CA 93033

The public key system used by Charlie Merritt is not the one discussed in Infoworld. This one is based on factoring large numbers. My research indicates that it will take the resources of a government to break the Merritt system, and I wouldn't bet that a government can do it. Charlie Merritt has invited any computer wizards who are interested to

try to disassemble his program for all the good it's going to do them. . . . Jerry

Europe Replies

Dear Jerry,

From time to time in your column a European standard emerges as a culprit for what-they-did-to-the-Selectric-keyboard on the IBM PC. As you certainly are aware, a disturbing number of languages are spoken in Europe—English, German, French, Spanish, and Italian, for example. For each language there is a traditional keyboard that may or may not have achieved the dignity of a standard. Further, European keyboards differ not only from language to language but also from country to country. The "German" keyboards in West Germany, Austria, Switzerland, and Luxembourg are by no means identical. Surely there must be more to the PC's keyboard than a ghost?

G. Accardo
6225 Hersberg 7
Luxembourg

I know only what the sales and public relations people tell me. At any rate, there are now software fixes, so all's better if not well. . . . Jerry

Dear Jerry,

You have commented a couple of times in BYTE on the IBM PC keyboard. For the record, the features of the keyboard you have criticized are all designed in the U.S. and are as American as pie and Watergate. To wit: key placement, key spacing, and so on.

The one keyboard feature that has been influenced by European norms is height, which you have not criticized. There are no European keyboards that have a key between the space bar and shift *except* for IBM PC keyboards imported from the U.S. Umlauts sit way above the shift key.

Have you got something against Europe?

V. M. Lorenzen
Raiffeisenstr. 1
Seeheim
West Germany

IBM and DEC both said it was a European standard. Great gobs of goo. . . . Jerry

OF ALL THE THINGS YOU BUY, HOW MANY ARE GOOD ENOUGH TO BE WARRANTED 5 YEARS?

Few disks stand the test of time. Because few are built to the precision standards or certified to the critical levels of Omni's complete line.

Each Omni disk is rated for 12 million passes without disk-related errors or significant wear. Each is certified error-free at a minimum of twice the error-

threshold of your system. And built to exceed all industry specifications including those of ANSI, ECMA, ISO and virtually every drive manufacturer. So you can count on them for the long haul. We guarantee it.

Call toll-free (800 343-7620) for your nearest dealer. In Mass., call 617 799-0197.

Omni Resources, 4 Oak Pond Ave., Millbury, Mass. 01527

Dealers. Software houses. Check our prices, services and specifications. We offer duplicating, formatting, private labeling, small minimums, fast delivery and copy protection schemes on disks for virtually any system.

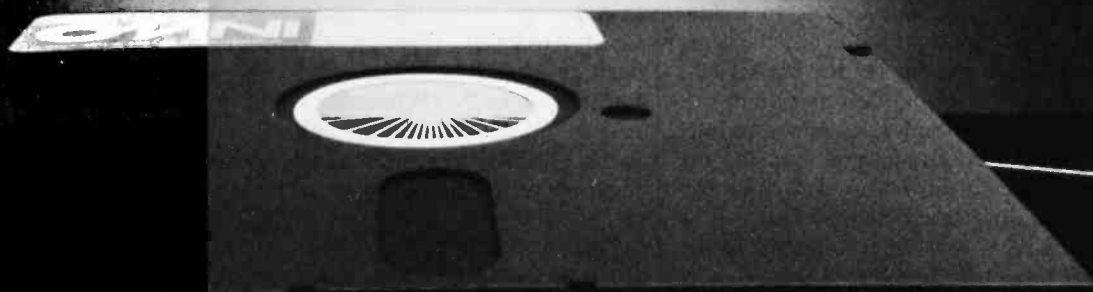

OMNI

**THE DISK GOOD ENOUGH
TO BE WARRANTED 5 YEARS**

Dear Jerry,

You keep harping on about the nasty "European" keyboard supplied with the IBM PC. Sure it's European, and sure it's nasty, but your moans are like complaining that a grapefruit is sour because it's yellow.

So far as I am aware, the "Europeanness" of the IBM keyboard only has to do with ergonomic attributes such as being separate from the rest of the machine and standing low above the table. In much of Europe, this sort of let's-mollycoddle-the-user "standard" gets called "Swedish." Look at the Basis—its keyboard is just as "European/Swedish," yet you said quite nice things about it the other month.

Manufacturers were making such a thing about meeting "Swedish" standards at last fall's Paris office equipment show (SICOB) that a friend of mine went to Stockholm to get copies of these "standards." It was like trying to reach the end of the rainbow. It seems that the much-vaunted Swedish ergonomic "standards" are actually stiff demands made by labor unions. All very well, except that they appear to be regulated by union whim.

Each European country has a different typewriter keyboard layout to cope with things such as "être ou pas être, c'est là la question." But that is not what you are complaining about, either: important things, like where to put the big keys, are the same in Europe and in America. It's obvious if you stop to think about it: little typewriter keytops are easy for manufacturers to swap around, but changing the physical locations of the big keys for each country would be uneconomic.

The real bugbear is that many computer manufacturers and programmers do not know how to type in any language. Although IBM makes typewriters, it is noticeable that it was not the typewriter department that produced the PC.

Some programmers' lack of typing ability is astonishing: when I first started word processing on an Exidy Sorcerer, I was flabbergasted by a table of "single keystroke" entries for BASIC keywords—as though a two-key combination such as "graphic-G" could conceivably be easier than typing TAB(, opening parenthesis and all! Clearly the BASIC manual was not directed at word-processing customers.

Many utility programs are just as bad. I find it is easier and quicker to type out short, meaningful command words such as ENTER in full rather than try to

remember the current program's one- or two-letter abbreviation, but I've seen competent systems programmers boggle at the prospect of hunting for, and then pecking at, five whole letters in the right order just for one command. Why require five acts where one will do?

You might well do good by castigating neglect of the touch-typist by IBM and the rest of the programming world, but blaming it on Europeans in general, or Swedes in particular, is wide of the mark. By the way, I have no special pro-Sweden axe to grind, and although I live just outside Paris, I'm British.

Andrew Marland
35 Avenue Chevreul
92270 Bois Colombes
France

I don't mean to blame Europeans, but IBM's short-sightedness! They had the best keyboard in the world (Selectric), and they blew it! . . .
Jerry

On Comments

Dear Jerry,

I have a quick comment on your use of comments in a Modula-2 program. I think I can cast some insight on the situation. Your statement that it is clearer if FOR ends with NEXT, and WHILE with WEND, makes sense only in the context of your ongoing enthusiasm for advanced versions of BASIC. However, for someone such as myself, who has never used a BASIC with WEND in it, using WEND to end a loop seems no more natural than using QWERTY. I would suggest commenting your example program thusly:

```
While n < N DO
  FOR i := 1 TO 5 DO
    WriteString("Foo")
  END; (* FOR i *)
  WriteString("Fiddle");
  DEC(N);
END; (* WHILE n < N *)
```

Using comments that indicate the loop variables allows the reader to simply look upward from the comment until he finds the loop statement with the same variables. With your method, all he can do is *hope* to find the corresponding WHILE statement. For nested WHILEs in particular, simply putting WEND won't do the job. Note that this affords the same

ease of reading that NEXT I (rather than just NEXT) does. But bringing in NEXT is unnecessary, as is WEND.

As for your columns, they are always provocative and informative, even if I don't always agree. Keep it up.

Matt Richards
815-C Dartmouth Rd.
Baltimore, MD 21212

Seems like a good idea. Meanwhile, Modula-2 remains my favorite language. . . .
Jerry

Z-100 Notes

Dear Jerry,

Poverty drove me to the Heath version of the Z-100. It is relatively easy to assemble and very well documented. One needs to be light of touch with a soldering iron on the controller board, but otherwise the kit is within the skill level of the average tinkerer. My unit came on line after only about 10 hours of effort.

I must also report that one of the claims made in the advertising is significantly overstated. The 8-inch drives that you connected up so easily must have been double-sided, for it seems that only double-sided drives will work with this machine. That was a serious blow to me because the ability to use my old drives was the economic cornerstone of my decision to launch this project.

I have called Heath to ask whether a single-sided drive can be made to work, but after the first contact, which revealed that a BIOS patch was available, the help came to an end. You would be surprised at how long Heath technicians can hold their breath on the phone! It's hard to believe that they think they will sell too many of the \$2700 disk drives using this tactic when equivalent drive systems are available for less than half that price on the open market.

Jerry, if your technical friends come up with a way to make Shugart 800 drives work with the Z-100, I'd surely like to hear about it.

Colin Evans
150 Walnut St.
Stratford, CT 06497

Others also report that the Heathkit version of the Z-100 is easy to build. I'm glad you were happy with yours.

Alas, I know of no way to use single-sided

Introducing...the Byte Book Club™

FORMERLY COMPUTER PROFESSIONALS' BOOK CLUB

POWERFUL TOOLS! POWERFUL SAVINGS!



Take any 3 books
for \$1.00
only each
(Values up to \$79.50)

If you join now for a trial period and agree to purchase three more books—at handsome discounts—during your first year of membership. (Publishers' prices shown)

MICROPROCESSOR APPLICATIONS HANDBOOK By D. R. Stout
617/988B \$39.95
(Counts as 2 of your 3 books)

NETWORK SYSTEMS By R. Sharma, P. J. T. deSousa, A. D. Ingle
582557-0B \$29.95
(Counts as 2 of your 3 books)

SOFTWARE ENGINEERING: A Practitioner's Approach By R. S. Pressman
507/813B \$32.95
(Counts as 2 of your 3 books)

CIARCIA'S CIRCUIT CELLAR, Volume 2 By S. Ciarcia
109/63X \$11.95

COMPILER CONSTRUCTION: Theory and Practice By W. Barrett, and J. D. Couch
788/499B \$25.93
(Counts as 2 of your 3 books)

AN INTRODUCTION TO VISUAL CALC® MATRIXING FOR APPLE® AND IBM® By H. Anbarlian
016/054 \$22.95

BUILD YOUR OWN Z-80 COMPUTER—and Z80 USERS MANUAL By S. Ciarcia & J. Carr
582337-3B \$29.90
(Counts as 2 of your 3 books)

MICROCOMPUTER OPERATING SYSTEMS By M. Dahmke
150/710 \$16.95

THE MCGRAW-HILL COMPUTER HANDBOOK By H. Helms
279/721A \$79.50
(Counts as 3 of your 3 books)

MICROCOMPUTER BUYERS' GUIDE By R. Webster
689/598 \$19.95

APPLE PASCAL By P. Luehmann
491/712 \$18.95

MICROCOMPUTER GRAPHICS AND PROGRAMMING TECHNIQUES By H. Katzan, Jr.
582576-7 \$18.95

BASIC: GETTING STARTED By W. S. Davis
582355-1 \$5.95

INTERFACE PROJECTS FOR THE TRS-80 By R. C. Hallgren
582466-3 \$18.95

PRINCIPLES OF INTERACTIVE COMPUTER GRAPHICS, 2/e By W. M. Newman & R. F. Sproull
463/387B \$35.50
(Counts as 2 of your 3 books)

THE SMALL COMPUTER CONNECTION By N. L. Shapiro
564/124 \$15.95

INVITATION TO FORTH By H. Katzan, Jr.
582284-9 \$17.50

A PROGRAMMER'S VIEW OF INTEL 432 By E. Organick
477/191B \$29.95
(Counts as 2 of your 3 books)

DATABASE DESIGN 2/E By G. Wiederhold
701/326B \$32.00
(Counts as 2 of your 3 books)

CONVERSION OF COMPUTER SOFTWARE By J. R. Wolberg
582588-0 \$19.95

THE C PRIMER By L. Hancock & M. Krieger
259/81X \$14.95

INTRODUCING THE UNIX SYSTEM By H. McGilton & R. Morgan
450/013 \$18.95

PROGRAMMING WITH ADA: An Introduction by Means of Graded Examples By P. Wegner
789/24X \$19.95

Why YOU should join the Byte Book Club now!

- **Best and newest books from ALL publishers!** Books are selected from a wide range of publishers by expert editors and consultants to give you continuing access to the best and latest books in your field.
- **Big savings!** Build your library and save money too! Savings range up to 30% or more off publishers' list prices—usually 20% to 25%.
- **Bonus books!** You will immediately begin to participate in our Bonus Book Plan that allows you savings up to 80% off the publishers' prices of many professional and general interest books!
- **Convenience!** 14-16 times a year (about once every 3-4 weeks) you receive the Club Bulletin FREE. It fully describes the Main Selection

and alternate selections. A dated Reply Card is included. If you want the Main Selection, you simply do nothing—it will be shipped automatically. If you want an alternate selection—or no book at all—you simply indicate it on the Reply Card and return it by the date specified. You will have at least 10 days to decide. If, because of late delivery of the Bulletin you receive a Main Selection you do not want, you may return it for credit at the Club's expense.

As a Club member you agree only to the purchase of three additional books during your first year of membership. Membership may be discontinued by either you or the Club at any time after you have purchased the three additional books. Orders from outside the U.S. cannot be accepted.



Fill out the card and mail today! If the card is missing, write to:

BYTE BOOK CLUB™, P.O. Box 582, Hightstown, New Jersey 08520

User to User

drives; mine are indeed double-sided (CompuPro), and I never did check for single. Sorry.

We use the Z-100 primarily with 5¼-inch disks, but we like the ability to transfer to 8-inch disks easily.

If anyone writes with a simple way to use single-sided 8-inch drives, I'll be sure to put it in the column. . . . Jerry

Dear Jerry,

I finished assembling the Heathkit version of the Z-100 in March. I'm writing to tell you how to fix Zorro's squeaky keyboard. I also think that the squeak is needless on such a fine keyboard. Further, a blinking cursor makes me want to kill. I have spent sleepless nights developing horrible tortures for engineers that think I need the cursor to blink blink blink blink blink blink at me while I'm trying to think.

I've enclosed the listing of MODE.COM, which stops the squeak and the blink. The program is a minor modification of the one on page P.5 of volume 2 of the Z-DOS manual. The program could be further modified to reset anything on the machine by changing the MESH line. I've put MODE.COM into the AUTOEXEC.BAT file.

About the Heathkit H-100—it is incredibly easy to assemble. At \$2199 you are stealing this computer. Except for the disk controller board there are only two solder joints in the entire project! If you don't like to solder you can farm out the controller to a friend you trust with a soldering iron. Pay him \$100, and you still save \$900 over the price of the Z-100. I built the main box in less than five hours.

The controller took me about 10 hours to solder, but I had no experience and was working very carefully.

Reinhard Koch
1500 Cloverdale Ave.
Winston-Salem, NC 27104

Thanks—that helps a lot! I don't much care for blinks, either. . . . Jerry

Jerry Pournelle welcomes readers' comments and opinions. Send a self-addressed envelope to Jerry Pournelle, c/o BYTE Publications, POB 372, Hancock, NH 03449. Please put your address on the letter as well as on the envelope. Due to the high volume of letters, Jerry cannot guarantee a personal reply.

Listing 1: The MODE.COM listing, which stops the squeak and the blink in the Heathkit version of the Z-100.

```
type mode.asm

TITLE 'MODE.COM' — SET UP MACHINE THE WAY I LIKE IT
PAGE ,132

.XLIST
INCLUDE DEFASCII.ASM
INCLUDE DEFMS.ASM
.LIST

PGMSEG SEGMENT
ASSUME CS:PGMSEG,SS:PGMSEG,DS:PGMSEG,ES:NOTHING
ORG 100H ; Position after program header

START:
MOV DX,OFFSET MESH ; GET ADDR OF MESSAGE
MOV AH,DOSF_OUTSTR ; GET FUNCTION TO OUTPUT MESSAGE
INT DOSI_FUNC ; PRINT MESSAGE
INT DOSI_TERM ; STOP PROGRAM
MESH DB ;ESC,BLINK CRSR OFF,ESC,KEY-SOUND OFF,CR,LF,END-CHAR
27,'x','27','x2',13,10,'$'

PGMSEG ENDS
END START
```

; As shown on page P.5 of the Z-DOS manual, create a COM file by entering:

```
;
;
; MASH MODE;
; LINK MODE;
; EXE2BIN MODE.EXE.COM
; ERASE MODE.EXE
;
;
; You now have MODE.COM.
```

B:



Computer Covers
Tailored to Protect Your Investment

FILL OUT

Dealer Inquiries Invited
Indicate Style #, Quantity and Amount.

For	Style #	Quantity	Price	Amount
Computer Covers				
IBM PC	PC1		\$23.95	\$64.95
APPLE II	AP2C		20.95	55.95
APPLE II (keyboard and monitor)	AP2KM		26.95	89.95
Commodore 64	C6		18.95	
APPLE Disk Drive Covers				
Single Disk Drive	AP1D		16.95	
Double Disk Drive (stacked)	AP2D		20.95	
Double Disk Drive (side-by-side)	AS2D		20.95	
Printer Covers				
EPSON (MX 80 Printer)	EP8		20.95	
EPSON	EP10		26.95	

In California add 6% sales tax.
Shipping & Handling: add \$1.50 for first item and \$1 for each additional item.
Overseas freight add 15% of total amount.
Send my order for TOTAL _____

Allow about two weeks for delivery.

Check M.O. MasterCard Visa

Account # _____ Exp. Dt. _____
Name _____
Phone _____
Street _____
City/State/Zip _____
Country _____

Fill out coupon and mail today to:
Oxford International, Inc., 6829 Convo Court
San Diego, CA 92111, USA • 619-573-0112

PRESENTING THE S100-PC™ FOR \$2999.

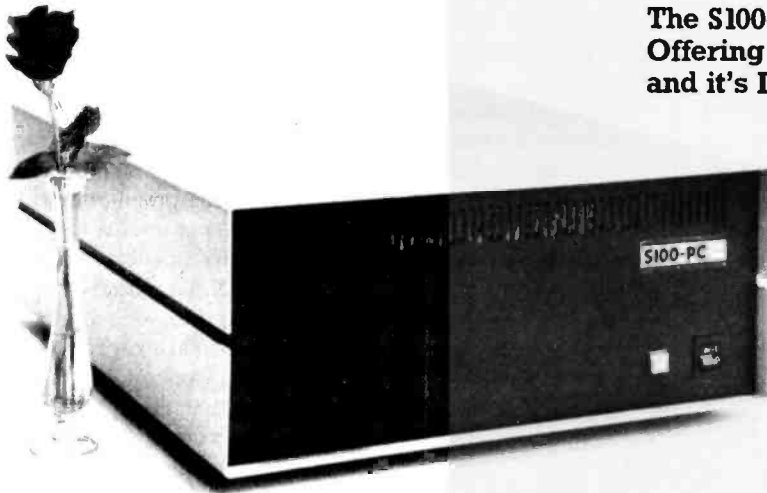

**The S100-PC by Lomas Data Products:
Offering high performance at a "low" price...
and it's IBM-PC diskette compatible.**

The S100-PC is a cost effective high performance floppy based system ideally suited to business and scientific applications.

The system offers the following standard features:

- Two 5 1/4" double sided disk drives (640 Kbytes of storage)
- Two serial ports, Two parallel ports
- Battery protected clock calendar
- MS-DOS** operating system (others optional)
- 128K RAM
- 8 MHZ 8088 processor (8087 optional)
- 15 slot S100 mother board
- Attractive desktop enclosure

And, the S100-PC is diskette compatible with the IBM-PC and most programs will operate without any changes. Plus, with its S100 bus expansion capability... your system will never be outdated.

LDP also offers a complete line of S100 bus board products & support for the system integrator . . .

■ **LIGHTNING ONE*** 8086/8088 CPU**
8086 or 8088, with 8087 and 8089 coprocessors. Up to 10MHZ operation. **PRICES start at \$425.00**

■ **HAZITALL SYSTEM SUPPORT BOARD**
2 serial, 2 parallel ports, battery protected clock calendar, Hard disk controller host interface. **PRICE \$325.00**

■ **LDP128/256K DYNAMIC RAM**
Advanced dynamic RAM with LSI controller for failsafe operation, parity.
Price 128K — \$495.00, 256K — \$795.00

■ **RAM67 HIGH PERFORMANCE**
STATIC RAM High speed (100ns) low power CMOS static RAM. 128K bytes, extended addressing.
PRICE \$1200.00

■ **LDP72 FLOPPY DISK CONTROLLER**
Single/double density, single/double sided disks, both 8" and 5 1/4" inch drives simultaneously.
PRICE \$275.00

■ **LDP88 8088 SINGLE BOARD**
COMPUTER 8088 CPU, 1K RAM, 8 K EPROM, Monitor RS232 serial port, 8 vectored interrupts. **PRICE \$349.00**

Two additional boards are available for JULY delivery.

■ **LIGHTNING 286 — 80286 CPU BOARD**
Offers 4 times the performance of a 5MHZ 8086 CPU while maintaining software compatibility.
PRICE CALL

■ **OCTAPORT 8 PORT SERIAL BOARD**
8 serial ports 0 to 19200 baud operation real time clock interrupt. Ideal for multi-user systems such as MP/M-86.* **PRICE CALL**

All of LDP boards are fully tested to exacting standards and carry a one year warranty. We specialize in 16-bit products & support the four major operating systems for 16-bit processors: CP/M-86*, MP/M-86, CONCURRENT CP/M-86*, and MS-DOS (PC-DOS).

If your application requires 16-bit computing power and versatility, call Lomas Data Products today.

LDP

Dealer inquiries invited.

LOMAS DATA PRODUCTS, INC. □ 66 Hopkinton Road, Westboro, MA 01581 □ Tel: (617) 366-6434

*CP/M-86, MP/M-86 and CONCURRENT CP/M-86 are trademarks of Digital Research.
**MS-DOS is trademark of Microsoft.
***Lightning One is trademark of Lomas Data Products, Inc.

Ask BYTE

Conducted by Steve Ciarcia

Joystick for the PC

Dear Steve,

I would like to build the joysticks for my IBM Personal Computer using Radio Shack's joystick potentiometer, Catalog No. 271-1705. Can you tell me how to wire up the potentiometer? The IBM manuals have been no help. Also, I hooked up a 13-inch Hitachi color television set to the IBM PC, but

I get poor resolution in the 80-character by 25-line mode. Any suggestions?

Robert Smith
Darien, CT

Adapting the Radio Shack joystick potentiometer to the IBM Personal Computer is easy (see figure 1). Of course, your PC will need a joystick interface card. Also, while the value of the 271-1705 joystick is rated at 100K ohms, the 30-degree travel of the

joystick handle may limit the range that can be controlled. If this is a problem, a potentiometer with a larger resistance will be needed. The total resistance change should be around 100K ohms.

The signal bandwidth of a color television is too narrow for an 80-character line to be displayed clearly. The only solution for sharp characters is to use a high-bandwidth (greater than 12 MHz) monitor. . . .Steve

Atari 800 to VCS

Dear Steve,

I own an Atari 800 and am interested in making cartridges for the Atari VCS or 5200. Do the VCS and 5200 both use a 6502 chip? If they do, is it possible to use standard Atari assembly language for programming? If they do not use the 6502—or are not compatible with Atari assembly language—can you tell me if there is any other way to make cartridges for the VCS or 5200? (I understand that there is a board that lets you use an Apple II Plus for this purpose.) Any help will be greatly appreciated.

Scott Brause
Edison, NJ

The Atari 800 and the Atari VCS both use a 6502-type microprocessor and share the same machine language. It is therefore possible to develop games on your Atari 800 that will run on a VCS.

The boards for the Apple II Plus are made by

Frobco
POB 8378
Santa Cruz, CA 95061
(408) 429-1551

These units are real-time development systems consisting of a plug-in board for the Apple II and EPROM plug-in boards for the VCS or 5200. . . .Steve

The Monitor and the Merriment

Dear Steve,

I have been using a BMC 13-inch color monitor with two home computers: a Commodore VIC-20 and a TI-99/4A. I also have another computer (built from an NRI kit) that is based on an

IBM CONNECTOR ON PADDLE BOARD

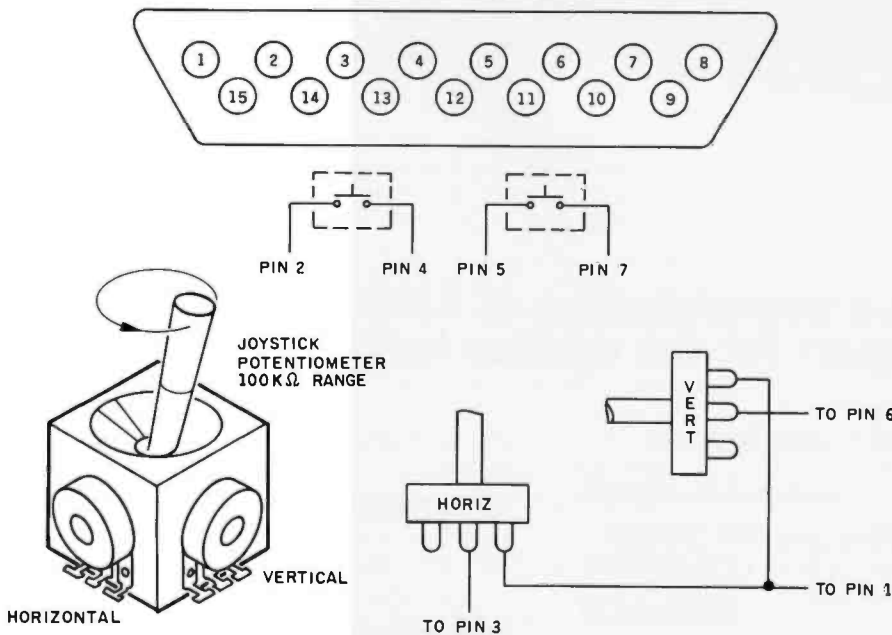

Figure 1: The technical specifications needed to employ a 100K-ohm joystick potentiometer as a joystick for an IBM Personal Computer.

Apple Disk Information

Dear Steve,

I would appreciate your help in finding sources of information about the operation (hardware and software) of the Apple II disk drives and disk-drive controllers.

Robert Kao
West Linn, OR

One of the best references on the operation of the Apple disk operating system is the book

Beneath Apple DOS by Don Worth and Pieter Lechner. Published by Quality Software, it is available at most computer stores. The book completely describes the DOS software and explains the disk formatting. Because many of the disk-drive functions are software controlled rather than hardware controlled, you will be off to a good start.

The Apple disk controller schematic on page 145 of the Apple DOS Manual shows that it does little more than turn

the drive on and off, move the stepper motor, and translate the disk pulses into a 6-bit hexadecimal code. The software that drives the controller is explained in Beneath Apple DOS. The disk analog card features the MC3470 read amplifier, which takes the differential AC signal from the disk's read/write head and converts it to a digital output pulse. It is amplified and filtered, sent to the controller for translation, and then sent to the data bus. . . .Steve

Now your computer can say anything and say it well. Introducing the Votrax Personal Speech System.

Quite articulate.

The unlimited vocabulary Votrax Personal Speech System is the most sophisticated, low cost voice synthesizer available today. Its highly articulate text-to-speech translator lets your computer properly pronounce conversational words at least 95% of the time.

For all those unusual words and proper names, you can define an exception word table and store your own translations. And remember, the entirely self-contained Votrax PS System gets your computer talking without using any valuable computer memory.

Built-in versatility.

Much more than just a voice output device, the Votrax PS System lets you mix either speech and sound effects or speech and music. A programmable master clock and 255 programmable frequencies give you unmatched control of speech and sound effects.

The Votrax PS System offers user expandable ROM for custom applications, user downloadable software capability and sound effects subroutines for easy user programming. Its programmable speech rate provides more natural rhythm, while 16 programmable amplitude levels give you greater control of word emphasis.

Actual size: 12.2" x 4.5" x 2.6"

Friendly to humans.

Designed to look like a printer to your computer, the Votrax PS System is extremely easy to use. It can be used in tandem with your printer without an additional interface card. Both serial and parallel ports come standard, allowing you to connect the Votrax PS System to virtually any computer. Speech, music and sound effects are only a PRINT statement away.

What to say after "Hello".

Businesses will appreciate spoken data transmission, narration of graphic displays and unmanned, oral product demonstrations. Spoken verification of data input will make computers much easier for the blind to use. School children can receive comprehensive

computer instruction with voice textbooks as well as spoken drills and testing. And then, late at night, you can make those adventure games explode.

A quick list.

- Highly articulate Votrax text-to-speech translator.
- 255 programmable frequencies for speech/sound effects.
- 16 amplitude levels.
- Simultaneous speech and sound effects or speech and music.
- 8 octave, 3 note music synthesis.
 - Serial and parallel interface standard.
 - User programmable master clock.
 - User defined exception word table.
 - User programmable speech rate, amplitude and inflection.
 - User expandable ROM for custom applications.
 - User downloadable software capability.
 - 3,500 character input buffer: sub-divisible for a printer buffer.
- Internal speaker and external speaker jack.
- Real time clock and 8 user defined alarms.
- Oral power up and error prompting.
- X-on/X-off and RTS-CTS handshaking.
- Programmable Baud settings (75-9600).
- Interrupt driven Z-80 microprocessor.
- Parallel/Serial interconnect modes.
- Proper number string translation: the number "154" is pronounced "one hundred fifty four".

To order, see your local computer retailer or call toll-free

1-800-521-1350

Michigan residents, please call (313) 588-0341. MasterCard, VISA or personal check accepted. The price is \$395 plus \$4 for delivery. Educational discount available. Add sales tax in Michigan and California.

© VOTRAX 1982

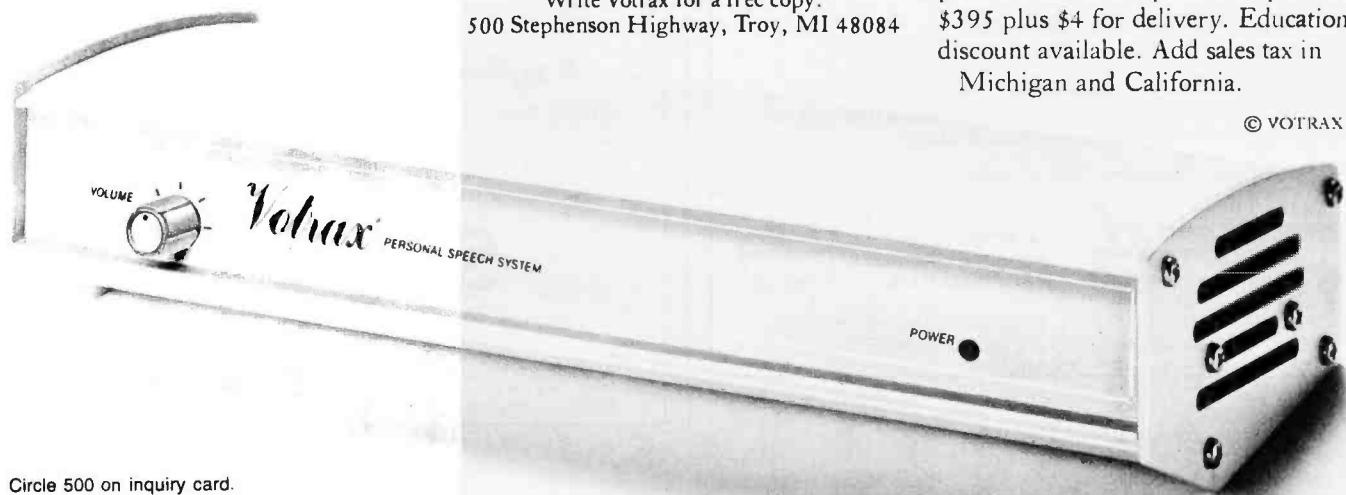

Circle 500 on inquiry card.

Ask BYTE

MC6802 microprocessor. This unit has memory-mapped video, uses an MC6670 character generator, and displays 24 lines of 32 characters on a television screen. How can I get it to display to my monitor?

Itshak Mihaeli
Brooklyn, NY

Your color monitor is designed to accept a composite video signal directly. A television receiver is designed to accept a composite video signal that is superimposed onto a radio-frequency (RF) carrier. Most low-cost computers, such as your NRI, provide the video output on an RF carrier (usually channel 3 or 4) to enable a home television set to be used as a monitor.

The VIC-20 and the TI-99/4A have a direct video output that is not modulated to a television channel. Their output can therefore be displayed directly on your monitor. The RF signal from

your NRI system is preventing the video signal from being displayed. If you tap into the composite video signal inside the computer before it goes into the RF modulator, you will be able to display its output on your monitor. . . . Steve

Power-Line Warning

Dear Steve,

I am about to receive a Victor 9000 system and would appreciate some information on a gadget that gives warning of power-line failures and glitches. Despite considerable searching, I have been unable to find the name or manufacturer of this minor piece of equipment and its price (though I understand that its cost is not high). Can you help?

Brian Rushton
Brooklyn, NY

The device for indicating

power-line failure and glitch occurrence, the Glitch Sentinel, is manufactured by

BMI Billings McEachern Inc.
402 Lincoln Centre Dr.
Foster City, CA 94404
(415) 570-5355

The Glitch Sentinel features indicator lights for a variety of power-line conditions including high and low line frequency, voltage spikes, and "noise." At \$400 to \$975 (with printer) per unit, I do not consider this a "minor piece of equipment" and suggest that you may be confusing this product with one of the many devices available that suppress surges and glitches. . . . Steve

Greek Character Set

Dear Steve,

I have both a Commodore PET 2001 and a VIC-20 and would like to find a character

generator for both that will display the Greek character set.

Dafni Voulgaridou
Thessaloniki, Greece

Two programmable character generators for the PET have been advertised within the last year. The first, the ICT Programmable Character Generator, is available from

Micro Mini Computer World
74 Robinwood Ave.
Columbus, OH 43213

It allows the user to reprogram any of the PET's 256 standard screen characters and would certainly allow the use of Greek characters.

The other unit is manufactured by

Systems Formulate
Corporation
39 Town & Country Village
Palo Alto, CA 94301

Eco-C TM Compiler

Since November of last year, we've been testing our new Eco-C Compiler and now it's ready for your Z80™ CP/M™ system. Some of the features include:

- All data types, including float, double and long.
- Fast, efficient code. For example: Our versions of "seive" in January, 1983, BYTE; 15.8 seconds (standard) and 11.7 seconds (optimized).
- Uses Microsoft's MACRO 80™ for REL file output.
- Standard (K&R) file I/O and library (most in source) included.
- Easy assembly language interface.
- No royalty fees on generated code.

The price for Eco-C is \$350.00 and includes MACRO 80 (a \$200.00 value by itself). We'll also include a free copy of C Programming Guide while supplies last.

For further information, call or write:



P.O. Box 68602
Indianapolis, IN 46268
(317) 255-6476



Registered trademarks are: Zilog (Z80), Digital Research (CP/M), Microsoft (MACRO 80) and Ecosoft (Eco-C).

MICRO WAVES

NEW!
FOR DEC PRO 350

SPSS Inc. is making waves with a powerful new line of statistical software for the serious data analyst.

- ❑ Simple and sophisticated statistics; 25 procedures including cross-tabulation and regression
- ❑ Advanced Report generator
- ❑ Comprehensive data management—files of any size

SPSS/Pro is currently available for the DEC Professional 350. Other conversions are underway. At SPSS Inc. we're making waves every day. Call us for the full story. 312-329-2400

SPSS inc.

444 N. MICHIGAN AVE., CHICAGO, IL 60611
(312) 329-2400

SPSS, SCSS, IDA, SPSS/Pro are trademarks of SPSS Inc. for its proprietary computer software. DEC Professional 350 is a trademark of Digital Equipment Corporation. © 1983 SPSS Inc.



Reserve your place today. We'll give you a front-row seat to success.

ISE-USA Professional Training Seminars on Microcomputer Application Development

The microcomputer is here to stay. As a smart Information Management Professional you know that micros are rapidly becoming a key to business success.

Learn how to use them wisely, and you'll be able to take full advantage of the growing micro revolution. Build top quality application systems on micros, while maintaining data integrity and security, and you could save a small fortune. Or make one.

That's why ISE-USA has developed this special training program—to help you understand the fundamentals of data base management systems *and* to show you how to solve the kinds of problems you could formerly solve only on a mainframe.

It's the kind of in-depth, practical, concentrated learning program you need to update your thinking, and discover the true potential of today's micros.

Three-day Seminar and Workshop on Microcomputer Application Development

Basic principles and inner workings of data base management: a must for anyone who wants to stay abreast of today's rapidly evolving information processing technologies.

Learn such valuable techniques as...

- State-of-the-art data base management
- How to design logical data structures for your application problems and create effective, efficient application software solutions
- How to assure data integrity and utilize recovery procedures
- Taking full advantage of tools for ad hoc query processing and interactive data manipulation
- Guaranteeing data security, handling multiple simultaneous users, performance tuning, design modification, and more

Taught By: Leading authorities on microcomputer data base management for applications systems development.

Sponsored By: International Software Enterprises, Inc. (ISE-USA), a member of the worldwide network of ISE companies.

In Cooperation With: Micro Data Base Systems, Inc. (MDBS), one of the world's leading microcomputer software firms; creators of superior data base management software for mini and microcomputers and the first company to develop an authentic, full-featured data base management system for a wide range of microcomputers.



Guarantee

ISE-USA assures all attendees that only proven and available state-of-the-art microcomputer software development tools will be used in this seminar. Chief among these is MDBS III, an extended network, post relational DBMS which is preferred worldwide for serious micro application development. Many of its features are not yet available on mainframe DBMSs.

MDBS III is a trademark of Micro Data Base Systems, Inc.

Enroll me today! Enclosed is a check or money order for \$500*.

Sounds great, but I need more information.

*Illinois residents, please add 6% sales tax.

Name _____

Title _____

Company _____

Phone () _____

Address _____

City _____ State _____ Zip _____

MAIL TO: ISE-USA, 85 West Algonquin Rd.,
Arlington Heights, IL 60005

OR CALL: (800) 323-3629, In Illinois call
(312) 981-9200

Another device, the Soft ROM, consists of a board that plugs into your character generator's ROM socket and provides 4K bytes of RAM to create a customized character generator. An alternate character set can then be loaded into this RAM and switched. This card is available for \$129 from

Canadian Micro Distributors Ltd.
365 Main St.
Milton, Ontario L9T 1P7,
Canada

A foreign-language ROM for Commodore systems is available from

Kobetek Systems Ltd.
Rural Route #1
Wolfville, Nova Scotia
B0P 1X0, Canada
(902) 678-7771

You should contact them for specific information.

Also, I refer you to an article on creating custom character sets for the VIC-20 computer. This article, "Pixelator" (Compute!, October 1982), shows how to obtain an alternate character set. The principles can also be applied to the PET. . . Steve

Pascal Primers

Dear Steve,

I am trying to learn Pascal and need a good book to help me. There are many Pascal books on the market, but I don't know which would be suitable for me. I have been using BASIC for over three years, so I'm not exactly a beginner with micros or software. Can you recommend an appropriate book for me?

James Smith
Pinellas Park, FL

Many excellent books on Pascal programming are avail-

able, but I will list three that may be of special interest to you.

Pascal from BASIC by Peter Brown (BYTE/McGraw-Hill) emphasizes the advantages of structured programming and presents the concepts required to adapt Pascal to your computer. It builds on your previously acquired BASIC skills.

Introduction to Pascal by James Welsh and John Elder (Prentice-Hall) provides short, illustrative programs and a series of 17 case studies. It is written for the beginning programmer.

If you own an Apple II computer, an excellent book is Apple Pascal—A Hands-on Approach by Arthur Luehrmann and Herbert Peckham (McGraw-Hill). This is a tutorial guide to Apple Pascal designed to be used with an Apple II. . . Steve

CP/M on an Elf

Dear Steve,

I have an expanded version of the Elf II 1802-based computer with 64K bytes of RAM, an ASCII keyboard, and Level III BASIC. How can I run CP/M on this system? Can a Z80-based computer be interfaced with the Elf system to use its RAM and other accessories?

Barry Dyar
APO New York

CP/M was written for an 8080 microprocessor and it will also run on 8085 and Z80 chips, but it cannot be directly implemented on an 1802. However, a Z80 microprocessor could be interfaced to the Elf's bus (similar to Microsoft's Z80 card for the Apple II) to use existing memory and I/O ports. CP/M could then run on this hybrid system. I have never tried this combination and am not aware of any commercially available boards to accomplish it. You might try writing to

**2 chips
... are
better
than
one**

Is your Apple's 6502 processor chip a little overworked lately? Have you been eyeing one of those new, 16-bit systems? But you don't want to give up all your Apple programs ...

Add the powerful 16-bit 8088 processor to your Apple with ALF's Processor Card. Let the 6502 and 8088 work together to tackle your toughest problems—like speeding up your Applesoft and Apple Pascal programs. With the Processor Card, you can use the CP/M™ 86 or MS-DOS™ operating system to run the latest 16-bit software, including many IBM PC programs.

64K or 128K of high-speed memory is available for ALF's Processor Card. Use the Processor Card with 128K as a fast disk emulator or to view sixteen hi-res images in under a second. Or run Basic, C, COBOL, or Pascal with 16-bit performance!

The ALF Processor Card is just \$395 (Applesoft speed-up software included). See your Apple dealer today, or contact ALF for more information.

Trademarks: "Apple"; Apple Computer, "CP/M"; Digital Research, "MS-DOS"; Microsoft.

ALF

ALF Products Inc.
1315F Nelson St. Denver, CO 80215
(303) 234 0871 Telex: 4991824

Netronics R&D Ltd.
333 Litchfield Rd.
New Milford, CT 06776

This company sells the Elf II and has CP/M on its Explorer/85 system. Perhaps it has worked out a combination of the two.

... Steve

E-Z Does It

Dear Steve,

I was very impressed with your E-Z Color Graphics Interface (BYTE Circuit Cellar, August 1982), but I feel that designing it for the Apple is like bringing coals to Newcastle. The article stated that an S-100 version was being planned; I have long felt that S-100 systems needed such a board for good games and graphics programs. Do you think that it would be feasible to combine the graphics support of the E-Z Color board with a sound generator and a joystick/paddle interface on an S-100 board?

My S-100 system has only one slot available at the present. Is there any way that I can increase the number of slots available? What I had in mind was something analogous to an extension cord with multiple outlets.

David Langan
Lafayette, LA

The S-100 version of the E-Z Color board features the TMS 9918A sprite graphics, an SN76489A sound-generator circuit (BYTE Circuit Cellar, July 1982), and an input port capable of reading two Atari joysticks. It's available from

Micromint Inc.
561 Willow Ave.
Cedarhurst, NY 11516
(800) 645-3479

Your idea of expanding the S-100 bus with "an extension cord with multiple outlets" is sound if the connecting cable is not too long and if the original socket had buffered address and data lines. Active or passive termination of the bus is recommended if the length is more than several inches. (See also Ask BYTE, August 1983, page 486.) ... Steve

BSR X-10 Revisited

I have occasionally referred to the BSR X-10 Home Control System in my articles and recently (BYTE Circuit Cellar, July 1983) described my disillusionment with the X-10. The following is part of a letter from John Dilday at Leviton Manufacturing Company that helps shed some light on this subject.

"My experience has shown

that the arbitrary switching you describe is caused by legitimate X-10 signals. The culprit is your ultrasonic controller and other similar "early consumer" transmitters. You will find that controllers with the buttons floating at 125 volts line potential are sensitive to power-line transients or electrical noise. Noise occurring as the controller chip is scanning the buttons can activate a controller just as if you had intentionally pressed a button. You can demonstrate this to yourself by monitoring the transmit LED. Whenever it flashes without an intentional command, it is transmitting as commanded by the power-line noise.

"There are several solutions to your arbitrary switching experience. One is to eliminate the sensitive controllers from your system and replace them with Leviton's Central

Control System devices that are not sensitive to noise. Another is to disconnect these controllers whenever they are not being used to actually transmit a signal. If you must leave the sensitive controllers on line, installing 0.02- μ F glass capacitors from each of pins 16-23 to ground has been found a satisfactory remedy.

"The X-10 signal standard is one that can be reliable. It requires a specific combination of events to activate a receiver: (1) a 121-kHz signal, (2) a signal coordinated with zero-crossing, (3) the proper 9-bit code for a specific device, and (4) the complement of the 9 bits. This signal standard results in a system that can be made to operate reliably on three-phase 277/480 volts down to your single-phase 240-volt home electrical system, or even a low-voltage twisted pair." ■

In "Ask BYTE," Steve Ciarcia answers questions on any area of microcomputing. The most representative questions received each month will be answered and published. Do you have a nagging problem? Send your inquiry to:

Ask BYTE
c/o Steve Ciarcia
POB 582
Glastonbury, CT 06033

Due to the high volume of inquiries, personal replies cannot be given. All letters and photographs become the property of Steve Ciarcia and cannot be returned. Be sure to include "Ask BYTE" in the address.

NEW! XEROX 16/8 PROFESSIONAL COMPUTER

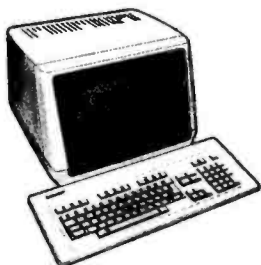

16/8 FEATURES:

8086 16-bit processor operating at 6.7MHz, 4MHz Z80A, 128K RAM (optional 256K), low profile keyboard with 12 function keys, separate cursor control pad. Operating systems include: MS-DOS, Concurrent CP/M-86 and CP/M-80. Upgrades from 820 and 820-II are available.

INTRODUCTORY SALE PRICES

	LIST	SALE
5 1/4" SS/DD	\$3395	\$2495*
5 1/4" DS/DD	\$3795	\$2795*
8" SS/DD	\$3745	\$3095*
8" DS/DD	\$4445	\$3395*
10 Mb Hard	\$5295	\$4495

*with Tandon Drives

CALL OR WRITE FOR COMPLETE CATALOG

XEROX 820-II SYSTEMS

	LIST	SALE
5 1/4" SS/DD	\$2595	\$1995*
5 1/4" DS/DD	\$2955	\$2295*
8" SS/DD	\$3295	\$2695*
8" DS/DD	\$3985	\$2995*
10 Mb Hard	\$4845	\$4095

*with Tandon Drives

microNEST

Box 545, 1700 Front Street
Fort Benton, MT 59442
CALL COLLECT TO ORDER:
(408) 739-4342 9-5 MDT, M-F

VISA, MC, Cash, CK, MO, COD Add 3% for VISA or MC
Add 3% for Ship/Handling. Via UPS. Minimum \$2.50

XEROX 820/820 II are trademarks of XEROX Corp.
CP/M is trademark of the Digital Research Corp.

Xerox 25 cps Daisy	\$1195	Wordstar	\$299	OKI M92	\$ 529	DEALER INQUIRIES WELCOME!
Xerox 40 cps Daisy	\$2095	Multiplan	\$219	M93	\$ 919	
Qume Sprint 11 + 40	\$1395	dBASE II	\$459	M84	\$1049	

WHY YOU SHOULD RECOMMEND A KAYPRO EVEN IF YOU DIDN'T BUY ONE YOURSELF

If you're happy with the computer you now own, we're happy for you. Because we both know what you went through to buy it.

More than likely, it was a long year's education that sent you into a complex maze of trial and error. You spent a lot of time asking questions in computer stores. More time hunting for answers in computer books. Even more time investigating all the hardware, let alone software options you had to consider.

It was a hard way to get what you needed. A year that earned you an honorary degree in computer engineering and the status of a computer buff.

But just between us buffs, would you recommend a year like that to a friend?

FOR THE FIRST-TIME BUYER, KAYPRO IS A GODSEND.

We think the 'hard way' is the wrong way to have to buy a computer. After all, a business person shouldn't be required to make de-

isions better left to an engineer.

Trying to find compatible interfaces and software packages alone would drive most people up the wall (remember?).

So, we've taken a different

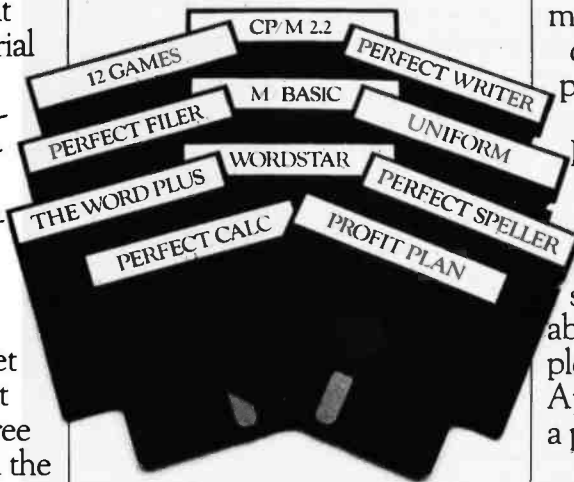

approach to making and selling our Kaypro II. Rather than a starter system, with options you buy piece for piece, it's designed with all the integrated hardware and software it needs to be fully functional.

Off the shelf, Kaypro II is completely ready for business. We think that's what the first-time buyer really needs.

IT'S A COMPLETELY INTEGRATED SYSTEM.

Since we don't consider a monitor, disk drives, interfaces or

other hardware as optional extras, all Kaypro's hardware comes complete in an integrated system. Except, of course, for a printer. As you know, some people don't need one. And those who do must decide whether they need dot matrix or letter quality printing.

What's complete on a Kaypro II?

64K RAM, Z-80 micro-processor. A 9" green screen monitor. Dual disk drives, the same used by IBM. A detachable keyboard that's more complete than you'll find on the latest Apple. Built-in interfaces for both a printer and communications.

In other words, all the hardware you'd recommend to a first-time buyer. In one complete package.

IT COMES COMPLETE WITH SOFTWARE.

While businesses can be very different, the fact is that 95% of all business needs can be fulfilled by a series of three business applications programs. Word Processing/Spelling, Data Base Management and Financial Spreadsheets.

It's the software that's optional with other computers.

But it too comes complete with a Kaypro.

And with its CPM operating system, Kaypro II is capable of running thousands of other business programs, to fill more specialized needs.

IT SELLS FOR \$1595, COMPLETE.

People are bound to ask you how much they should spend on a computer. There is, of course, an obvious answer: as little as possible and still get a serious business system, complete with all the functions they need.

At \$1595, Kaypro II is the least expensive serious business system we know of on the market today.

There are basic starter systems advertised for less. But their optional hardware and software can double or triple their basic price. So they can end up costing \$2000-\$3000 more than a Kaypro.

A good example is an Apple IIe. With a hardware configuration comparable to Kaypro II's, complete with comparable software, it lists for an average price of \$4400. \$2805 more than a Kaypro.

IT OFFERS MORE MEMORY FOR THE MONEY.

Since disk drive memory capacity is always a concern, once again the idea is to get the most for the money. With two disk drives, Kaypro II gives you 400K for \$1595. With equivalent hardware, an IBM gives you 320K for about \$2800. And Apple IIe gives you 286K for about \$2400.

So once again, Kaypro II delivers.

IT HAS POWER TO SPARE FOR WHAT MOST BUSINESSES NEED.

The more you love computers, the more tempting it is to recommend a 16-bit vs. 8-bit

machine. You know that 16-bit systems are a little faster and have more power to run longer programs.

However, 16-biters are far more expensive than the 8-bit variety. And, unfortunately, have only a handful of business applications software packages that really take advantage of them.

SPECIFICATIONS	
Microprocessor	Perfect Filer
Z-80	Perfect Calc
Operating System	spreadsheet
CP/M 2.2	Wordstar word processing
User Memory	The Word Plus
64K	Profit Plan
Disk Drives:	spreadsheet
2 drives, 400K, unformatted	M-Basic
Interfaces	12 Games
1 Serial	Uniform—allows computer to
1 Parallel	'read' and 'write'
Keyboard	TRS-80, Osborne, Xerox disks
Detached, 63-key with numeric keypad	Dimensions
Software included:	Height: 8 inches
Perfect Writer	Width: 18 inches
word processing	Depth: 15½ inches
Perfect Speller	Weight: 26 lbs. (portable)

Considering the real needs and budget limitations of most small businesses, why suggest a company limo when a good company car will do?

Since 75% of all micros sold today are 8-bit systems, it's indicative of their capacity to take care of business. We'd stick with a Kaypro II.

IT CAN PAY FOR ITSELF FASTER THAN MORE EXPENSIVE COMPUTERS.

Every business person wants a computer to pay for itself in increased productivity.

And the faster the better. Perhaps on this count alone, Kaypro II is worth recommending.

As a fully functional business system for \$1595, Kaypro can win the payout race hands down.

IT'S BECOME A LEADING SELLER THANKS TO COMPUTER BUFFS, LIKE YOU.

In fact, Kaypro II is one of the best sellers in the \$1000-\$5000 price range. And it got there largely because of the enthusiastic word of mouth, and word of press, of computer enthusiasts. Many of whom, after building their own systems, bought a Kaypro II as their second computer.

So you certainly won't be alone if you recommend Kaypro II to anyone shopping for a first computer.

Or look at it this way. Once you tell people about the complete business computer for \$1595, they'll probably stop bugging you with a lot of questions.

They may even forget to ask why you didn't buy a Kaypro II for yourself.

Just between us buffs, we can't recommend a good answer for that.

CALL 800-447-4700 FOR THE DEALER NEAREST YOU.

Circle 540 on inquiry card.

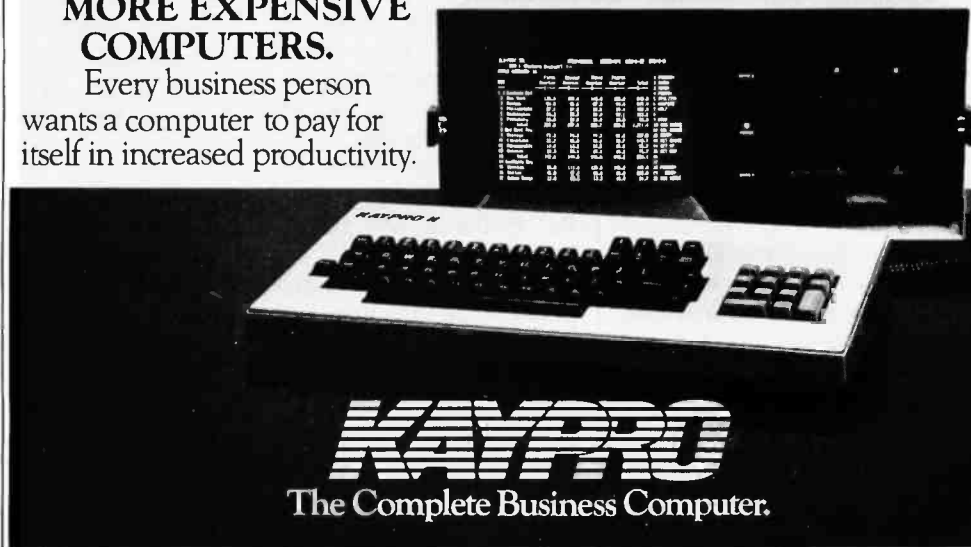

Software Received

Apple

Bookends, a reference-management system that keeps track of information from articles, books, and magazines alphabetically using authors and keywords. This program offers storage and retrieval. For II Plus, IIe, and III; floppy disk, \$124.95. Sensible Software Inc., 6619 Perham Dr., West Bloomfield, MI 48033.

The Chambers of Vocab, an educational game that builds vocabulary skills. Your goal is to work your way up and out of the Chambers of Vocab by demonstrating vocabulary skills. Up to four players can choose from three difficulty levels. For II, II Plus, and IIe; floppy disk, \$48.96. Reader's Digest Services Inc., Pleasantville, NY 10570.

The Cheap Assembler, a menu-driven, interactive editor/assembler system that lets you edit, assemble, list, and execute 6502 assembly-language programs without leaving the system. The program includes editor commands, assemble-time error messages, and assembler syntax. For II Plus and IIe; floppy disk, \$23.50. Thunder Software, POB 31501, Houston, TX 77231.

Home Investment Package, a series of three sections: the stock-tracking program, the compound-interest program (for any account that offers a compounded interest), and the main menu, which allows you to move from the stock program to the compound-interest program. For II Plus and IIe; floppy disk, \$15. Yes Software, 220 McKee Ave., Oxford, OH 45056.

Pensate, a thinking game of evasion. The object is to get

to the top of an 8 by 8 grid while avoiding other playing pieces. All ages can play. For the II Plus; floppy disk, \$19.95. Penguin Software, 830 4th Ave., Geneva, IL 60134.

Tactical Armor Command, a game simulation of World War II in which you pick a nation, build a combat team from powerful tanks, assault guns, and tank destroyers, and command the team you've created against the enemy. For II, II Plus, and IIe; floppy disk, \$40. The Avalon Hill Game Co., 4517 Harford Rd., Baltimore, MD 21214.

Ultimaker II, a game program that allows *Ultima II* players to boost their character's abilities and print maps of many areas of the game. It also includes a program of playing hints that you use at your discretion. For II and II Plus; floppy disk, \$14. Amazing Software, 625 Wellington St. N, London, Ontario N6H 3E8, Canada.

Atari

Paris in Danger, a multilevel simulation game of the December 1814 campaign to crush Napoleon. When two or more enemy corps engage, combat becomes tactical on a strategic map of Western Europe. For the 800; floppy disk, \$35. The Avalon Hill Game Co., 4517 Harford Rd., Baltimore, MD 21214.

Solar Storm, an adventure game. Strapped in your laser ship, you must battle fierce aliens that approach in waves of increasing velocity. In addition, the sun explodes and showers heated fragments on your vulnerable

planet. See if you can survive. For the 2600; cartridge, \$29.95. Imagic, 981 University Ave., Los Gatos, CA 95030.

CP/M

Fallout, a fallout-prediction and shelter-design program that lets you analyze any location in North America under various attack scenarios and size a shelter for the location. This program includes an accessible database of over 1200 targets, 300 weather stations, multiple targeting, user-selectable attack cases and winds, and easy-to-understand summary outputs. Floppy disk, \$29.95. Go Software, POB 2693, Chicago, IL 60690.

Organizer II, a utility package that lets you display, explain, and execute hundreds of applications, utilities, and system functions. You can also develop your own special menus. Floppy disk, \$149. The Information People, 443 Hudson Ave., Newark, OH 43055.

Pro Pascal, a programming-language compiler that generates native machine code for efficient program execution. Floppy disk, £220. Prospero Software Ltd., 37 Gwendolen Ave., London SW15 6EP England.

Z80ASM, a Z80 assembler in manual form with complete source-code listing and a tutorial on assembler theory. Includes standard Zilog mnemonics and manual. Easily revised as a cross-assembler. Floppy disk, \$50. King Software, POB 208, Red Bank, NJ 07701.

Commodore

Casual Writer, a utility package that lets your computer function like a word processor. No need to retype your entire text, just retype those words you need to change. Information can be stored on tape and easily recalled from tape for quick review. For the VIC-20; cassette, \$29. E.N. Publications, RR 1, Box V, Worden, IL 62097.

Deadly Skies, a fast-action arcade game. You must destroy the enemy's military base, missile emplacements, and many tanks. Avoid patrols, asteroids, and tracking bombs. For the VIC-20; cartridge, \$39.95. Tronix, 8295 South La Cienega Blvd., Inglewood, CA 90301.

Dr. Floyd, an interactive game that simulates artificial intelligence. You can converse with this program in the psychoanalytical technique used in client-centered therapy. For the VIC-20; cassette, \$14.95. Apropos Technology, Suite 821, 350 North Lantana Ave., Camarillo, CA 93010.

Gold Fever, an arcade-type game. Inside an abandoned gold mine, you must collect all the gold you can before your oxygen runs out. Avoid runaway boxcars, rolling boulders, and an evil claim jumper. For the VIC-20; cartridge, \$39.95. Tronix (see address above).

The Math Teacher, an educational math-tutorial program that drills students in math from first grade through junior high school levels. It contains 25 working math problems per session and displays student's scores. For the

COMMODORE 64

Commodore 1701 Color Monitor
14" screen-big screen, high quality
direct connect to 64 & VIC-20
Your LOW Cost: \$269.95



Commodore 1525E Printer
Quality dot matrix, direct
connect to Com. 64 & VIC-20.
No interface necessary.
Your LOW Cost: \$269.95

Commodore Datasette
Includes interface & cable,
for use with Com. 64 &
VIC-20. Your Cost: \$69.95

Commodore 1541 Disk Drive
High quality at low cost, direct
connect to Com. 64 & VIC-20.
Your LOW Cost: \$299.95

Commodore C1600 Modem
The best deal in the country for
a modem-Your LOW Cost: \$69.95

Commodore Software Package (30 programs)
only \$12.95 with the purchase of one of these packages:

COMMODORE 64 \$189.95*

COMMODORE 64 Computer—only \$189.95*
*when purchased with any of these packages:

COMMODORE 64	\$189.95
with the purchase of	
1 1541 Disk Drive	\$299.95
1 1525E Printer	\$289.95
ALL FOR	\$779.85

COMMODORE 64	\$189.95
with the purchase of	
1 1541 Disk Drive	\$299.95
1 1701 14" color monitor	\$269.95
ALL FOR	\$769.85

COMMODORE 64	\$189.95
with the purchase of	
1 1541 Disk Drive	\$299.95
1 1525E Fast printer-includes IFC/cable direct connect to 64	\$349.95
ALL FOR	\$839.85

COMMODORE VIC-20	\$74.95*
*with the purchase of	
1 Datasette program recorder	\$69.95
1 Gortek educational software	\$24.95
All for	\$169.85

COMMODORE 4040 Dual Disk Drive
Dual Disk Drive for the 64 & other models
340KB each-total storage 640KB
Come & try them-they're GREAT!
Retail: \$1295.00 Y/C: \$589.95

30 Programs for less than \$30!
Commodore Software Package \$29.95

NEW Impact Dot Matrix Printer by "Fidelity"
direct connect to VIC 20/Com. 64. 30 cps
ribbon cartridge, inc. adapter. Uses 2 1/2" plain
paper-tape-does graphics! Y/C: \$99.95 (90 day warranty)

DATA 20 Accessories:		
2 80 card	For Commodore 64	\$269.95
80 column card	For Commodore 64	\$89.95
40 column card	For VIC-20	\$99.95
40 column card	w/80 mem built-in for VIC-20	\$139.95
Video Pack 64K	For VIC-20	\$29.95

FREE with the purchase of each of the above ()
products—Word Master/word processing software,
Mailing List software & Telecommunications software.

IMMEDIATE DELIVERY!

FRANKLIN

FRANKLIN ACE 1000 —
APPLE COMPATIBLE!
64K with many more
features than Apple! Upper/
lower case, typewriter-style keyboard, VisiCalc keys.
Built-in fan, 12-key numeric pad & much more!
SPECIAL PACKAGE:

ACE 1000 computer (64K of RAM)
Disk drive w/controller
80 column card
Ace Calc - Spread sheet
Ace Writer - word processing software
12" green monitor
Epson printer or Star Gemini 10X
(Dot matrix printer, current model)
\$100 worth of software for Apple (retail \$)
Sugg. retail: \$2895.00 Y/C: \$1699.00

Package Two: Same as Special Package,
but with second Vista Disk Drive Y/C: \$1898.00

Package Three: Same as One & Two, but with
letter quality printer, instead of dot matrix:
w/Diablo 620 2629.00
w/SCM PT1 2238.00
w/Olivetti Praxis 41 1 2069.00
w/Brother 50 2069.00
w/C. Itoh F 10 2749.00

FRANKLIN PRODUCTS	
ACE 1000	749.95
ACE 1200 w/disk drive /controller	1469.95
Vista disk drive w/controller	269.95
Vista drive only	199.95
ACE Top (5)	179.95
ACE 80 CPU card	359.95
ACE display card	179.95
ACE dual interface	199.95
ACE 10 shielded drive cable	19.95
ACE I/O ext cable (5' parallel)	39.95
ACE I/O ext cable (5' Serial)	39.95

DO NOT BUY AN IBM PERSONAL COMPUTER
before you see & try the new SANYO MBC 550 Computer
which is an IBM PC clone at one-third the price!

The SANYO MBC-550
128K memory (expandable to 256K)
Powerful 16-bit 8088 CPU
160K disk drive (exp. to 640K w/two drives)
High quality, low profile
80-column display
MD/DOS operating system-(the defacto standard
of IBM compatibility)
Sanyo BASIC
Word Processing software
Spread sheet (VisiCalc-like) software
and more!
Your cost is NOT \$3,000 — \$2,000 — or even \$1,500
YOUR COST IS \$995.95

Optional
128K additional memory
8087 Number Cruncher co-processor
320K drives (2 provides over half a megabyte on line)
Hard disk available soon

Texas Instruments Home Computer

\$999.95 * TI 99/4A including the
\$50 TI rebate (you pay us \$149.95)
The only 16K COLOR computer
under \$100-16 bit-FAST!

Purchase of TI-99/4A includes One Year Full
Warranty & 2 1/2 hrs class from TI—also New
TI-Hot Line phone number.

FREE with the purchase of any of these TI packages, either Word
Processor, MultiPlan or LOGO (one only!)

Package one:	TI 99/4A Computer	\$500.00	TI 99/4A Computer	\$500.00
PHP 1250 Disk drive			PHP 1250 Disk drive	
PHP 1240 Disk controller card			PHP 1240 Disk controller card	
PHP 1200 Peripheral box			PHP 1200 Peripheral expansion box	
PHP 1260 32K expansion card			PHP 1200 Peripheral expansion box	
Sugg. retail: \$1199.00	Your cost: \$429.95		Sugg. retail: \$1199.00	Your cost: \$419.95*
			(after TI \$50.00 rebate-you pay us \$469.95)	
Package two:	TI 99/4A Computer	\$500.00	TI 99/4A Computer	\$500.00
PHP 1250 Disk drive			PHP 1250 Disk drive	
PHP 1240 Disk controller card			PHP 1240 Disk controller card	
PHP 1200 Peripheral box			PHP 1200 Peripheral expansion box	
PHP 1260 32K expansion card			PHP 1260 32K expansion card	
Sugg. retail: \$999.00	Your cost: \$319.95		PHP 2500 Printer (Epson 80)	
			Sugg. retail: \$1799.00	Your cost: \$949.00*
			(after TI \$50.00 rebate-you pay us \$999.95)	
Package three:	TI 99/4A Computer	\$500.00	TI 99/4A Computer	\$500.00
TI 99/4A Computer			PHP 1250 Disk drive	
PHP 1250 Disk drive			PHP 1240 Disk controller card	
PHP 1240 Disk controller card			PHP 1200 Peripheral expansion box	
PHP 1200 Peripheral expansion box			PHP 1260 32K expansion card	
PHP 1260 32K expansion card			PHP 4100 Color monitor	
Sugg. retail: \$1499.00	Your cost: \$529.95*		Sugg. retail: \$1699.00	Your cost: \$879.95*
			(after TI \$50.00 rebate-you pay us \$579.95)	

NEW TI-CC-40 Portable Computer from TEXAS INSTRUMENTS

\$189.95
NEW CC-40 Texas Instruments Compact Computer
NOW IN STOCK! Don't throw your money away
by buying a portable computer at \$800 or \$1000
the TI CC-40 will perform better at \$189.95!

HX-1000 Printer/plotter	\$179.95
HX-2000 Wafertape (digital tape drive)	\$124.95
RS-232 Interface	89.95
HX-3000 RS-232 int. w/parallel IFC	109.95
Solid state software/wafertape software-call us!	

IMMEDIATE DELIVERY

FRANKLIN ACE 1200 with 128K RAM
total dual processors-Two computers in one!
64K Apple compatible w/6502 processor
64K CP/M Z80-B processor inc. CP/M 2.2
and other features include: color, serial &
parallel IFC's, upper & lower case, etc.

Package One:
ACE 1200 dual processor, total 128K
Disk drive w/controller
Disk drive II only
40/80 column card
Dual IFC board, parallel/serial
Word Star software Sugg. retail:
Mail Merge software \$3500.00
AceCalc - spread sheet Y/C: \$1795.00
Welcome diskette

Package Two: Same as Package One with one Epson
printer or Star Gemini 10X plus one 12" green
monitor. Sugg. retail: \$4100 Y/C: \$2189.00

Same as Package One plus:
12" green monitor plus Letter Quality
printer:
w/Diablo 620 2879.00
w/SCM TP 1 2479.00
w/Olivetti Praxis 41 2299.00
5 language typewriter
w/Brother 50 2259.00
w/C. Itoh F10 2999.00
w/Silver-Reed EX43 2299.00
and many more, please inquire
Dpt'l interfaces & cables

SPECIAL OFFER TO ACCREDITED SCHOOLS—
on Commodore Executive 64, SANYO MBC 550,
& Franklin ACE 1000 & 1200—Buy 10 systems—
GET 1 FREE! CALL for details & eligibility!

DON'T BUY A PORTABLE COMPUTER
UNTIL YOU SEE & TRY THE NEW
PORTABLE COMMODORE EXECUTIVE 64!
Briefcase style 64K detachable, 5-inch color
monitor & built-in floppy disk drive. Compatible
w/software designed for the popular Commodore 64.

6510 CPU (6502 program compatible)
Built-in 5" color monitor
(40 col x 25 lines in 16 colors)
Built-in 170K disk drive (second drive opt'l)
External video port (64 compatible)
Full upper/lower case detachable keyboard
Commodore Serial Bus
External system bus (C-64 compatible)
Only 5" x 14 1/2" x 2.7 lbs
IEEE-488 IFC
Music & sound capabilities

with SINGLE DISK DRIVE
Your cost: \$995.00
with DUAL DISK DRIVES
Your cost: \$1195.00

HURRY! FREE SOFTWARE PACKAGE with your
purchase of the new Commodore EXECUTIVE 64
Portable Computer—ask for details when ordering!

It's about time! A NEW APPLE-COMPATIBLE
64K Computer with SWITCHABLE DUAL
PROCESSOR-THE ROMAR II. It has 6502 &
Z-80 processors; uses Apple software, CP/M
based languages, Applesoft, Basic, Cobol, Forth,
Fortran and Pascal. Optional plug-in boards
will allow this computer to support Integer Basic,
TRS-80, NEC-8001 and IBM CP/M-86.
Approved by the U.S. Consumer Service to sell
in the U.S.A. Includes 90-day warranty. It's
about time the consumer got a price break!
72-key typewriter-style keyboard
Numeric pad
Built-in fan
80-watts switching power supply & more!

SPECIAL PACKAGES—

Package One:
One 64K Computer
One disk drive w/controller
One 12" green monitor
Your cost: \$939.95

Package Two:
One 64K Computer
One disk drive w/controller
One second disk drive
Your cost: \$1069.95

Package Three:
One 64K Computer
One disk drive w/controller
One Epson RX80 or Star Gemini 10X
Your cost: \$1199.95

Individual prices:
Romar II 64K computer \$595.00
Disk drive w/controller 299.95
Second disk drive 199.95
12" green monitor 99.95

Due to the insane fluctuation
of prices in the industry-call
for current price-it may have
changed by the time this ad
appears.

hp HEWLETT PACKARD



HP-75C Computer	\$699.95	HP-41C Prog. calculator	169.85
8K module	164.95	HP-41CV Prog. calculator	219.95
7470A opt 003 print/plotter	1199.00	Digital watch	184.95
Call for math pac, surveying pac, text formatter & VisiCalc for HP-75C		Printer for 41C/VC	299.95
HP-10C Scientific calc	59.95	Card reader for 41C/VC	159.95
HP-11C Scientific calc	75.00	HP 82153A Video interface	259.95
HP-12C Financial calc	99.95	HP II systems on hand	
HP-15C Scientific calc	99.95	IL interface module	164.95
HP-16C Prog. scilic. calc	99.95	Digital cassette drive	379.95
HP-97 Prog. scilic. w/print	595.00	Thermal plotter/printer	379.95
		Extended function mem. mod	64.95
		Time module	64.95
		Memory module for 41C/VC	24.95
		Dual memory module for 41C	85.00

Brand	Model	Description	Your Cost
Diablo	620	Letter quality, 25 cps, hvy duty	999.95
Diablo	630	Letter quality, 40 cps	1799.95
Commodore	6400	(Diablo 630) 40 cps, heavy duty	1399.95
Juki	6100	Letter qual; 18 cps, has everything!	589.95
Qume	1140+	Letter quality, 40 cps, hvy duty	1369.95
NEC	7710	Letter quality, 55 cps, the best!	2095.00
NEC	3510	Letter quality, 35 cps, great unit!	1595.00
Olivetti	Praxis 41	Electronic T/W, 5 lang; inc. port	449.95
Epson	RX80	New printer, dot matrix	339.95
Epson	all models	All models inc. FX 80 - FX 100 & others	Call
Gemini 10X	120 cps, dot matrix, Epson compatible		339.95
Star	Gemini 15	120 cps, 132 col; Epson compatible	489.95
Transtar	120P	Letter quality, 14 cps, has it all!	499.95
Toshiba	P1350	Corres. quality, 4 modes, 180 cps, inc. parallel IFC	1769.95
Transtar	T315	Color printer, 50 cps, 30 color shades	499.95
Okidata	92P (No. 1)	Letter quality, 160 cps, dot matrix	569.95
Okidata	84P	200 cps-fast! dot matrix, corres. qual., 45 cps	1089.95
Okidata	83A	120 cps, serial & parallel, dot matrix	699.95
Okidata	2410P	350 cps-fast!, corres. quality, 85 cps-hvy duty	2499.95
NEC	PC 8023A	100 cps w/6 100 cps w/tractor & more! Parallel IFC	499.95
NEC	PC 8025	120 cps, pin/printer, 130 col; 3K buffer, parallel IFC	799.95
Anadex	OP-9500A	150 cps, parallel or Serial; 2K buffer	1399.95
Anadex	OP-9625A	200 cps; 50 cps correspondence quality	1699.95

OLYMPIC SALES COMPANY

P.O. Box 74545 216 S. Oxford Ave. Los Angeles, CA 90004
Phone (213) 739-1130 Cable "OLYRAV" LSA Telex: 67 34 77

Order Desks: 7:00 AM to 7:00 PM Mon thru Sat—TOLL-FREE: (out of CA) 800-421-8045 (in CA) 800-252-2153 TELEX: 67 34 77 CABLE: "OLYRAV" LSA
Goods subject to availability; this ad supersedes all previous ads. FOB our warehouse; prices subject to change without notice; not responsible for typographical errors; all orders subject
to verification; minimum shipping & handling: \$5.95. Send for our catalog—\$2 domestic, \$5.95 foreign. Some of the goods not available all stores—Call first to be sure!



IBM COMPUTERTECHNIK 68000-CPU for APPLEBUS

Now waiting has an end. For all computers with APPLEBUS a 68000 system is available.

Using UNIX is possible. Through a universal memory expansion and multi interface

you get a multi user systems for a low price.



- 68000 CPU with 7 Mhz clock frequency
- 128 KB RAM you can also use as a pseudodisk
- memory expansion to 1 MB obtainable
- Interrupt handling 6502-68000
- 14 bit timer from 20 μs to 163ms
- comfortable fullscreen Editor Assembler

Available software: Editor Assembler DOS 3.3 Forth for 68000 (with DOS 3.3) Pascal-, Basic-, Fortran (with UCSD-operating system) Compiler for 68000 CP/M-68K with C-Compiler

AP 20 Intemex with 68000 CPU and 128K RAM 650\$
AP 26 Memory expansion for AP 20 256K RAM extendable to 1Mb RAM 720\$
Prices for Software for inquiry

IBM COMPUTERTECHNIK Olper Str. 10 1011 Rose Marie Lane 16
 4800 Bielefeld 14 Stockton, CA 95207
 Tel. 05 21/44 4032 Tel. (209) 473-7473
 West-Germany USA

Software Received

64; cassette, \$39.95. Computech, POB 7000-309, Redondo Beach, CA 90277.

Neutral Zone, an arcade-type game. You are assigned to a perimeter gunnery pod to protect Alpha IV, a long-range early warning station that detects alien intruders. Engage the attack computer and take on a squadron of killer aliens. For the 64; floppy disk, \$34.95. Access Software Inc., 925 East 900 S, Salt Lake City, UT 84105.

Scorpion, a survival game. As a scorpion, you must find food to store at home and defend yourself from dragons, stalkers, and pods that abound in the maze. For the VIC-20; cartridge, \$39.95. Tronix (see address above.)

Type For Your Life, a graphic-action typing teacher for all levels. Typing speed can be set as high as needed and the text is widely varied. The graphics at the bottom of the screen keep eyes on the screen and add to the fun of learning. Alarms signal errors until they are corrected. For the VIC-20; cassette, \$14.95. Apropos Technology (see address above).

Wordplay, a collection of five language-oriented programs. Jargon writes sounding phrases; Story writes personal short stories based on your input; Animal guesses which animal you're thinking of; Haiku writes Japanese poetry; and Secret is a cipher/decipher code program. For the VIC-20; cassette, \$14.95. Apropos Technology (see address above).

IBM Personal Computer

C Compiler System, a utility program that accepts pro-

grams written in the C language and produces relocatable machine code in an Intel 8086 object-module format suitable for use by Microsoft LINK Linker. Floppy disk, \$500. Microsoft Corp., 10700 Northup Way, Bellevue, WA 98004.

Electric Ledger, an easy-to-use checking program for personal or small business accounts that balances your checkbook, reconciles bank statements, and computes mortgage loan and compounded amount. Features include easy data entry, menu drive, search, and sort to any keyword. Floppy disk, \$35. Datacon Consulting, 2311 West 5700 S, Roy, UT 84067.

Financial Planning for Supercalc, an electronic-spreadsheet enhancement program that lets you compute compound growth, annuities, discounted cash flows, profit planning, statistics, and real-estate finance. A quick reference guide is included. Floppy disk, \$89.95. Howard W. Sams & Co., 4300 West 62nd St., Indianapolis, IN 46268.

Financial Planning for Visicalc, an electronic-spreadsheet enhancement program that lets you compute compound growth, annuities, discounted cash flows, profit planning, statistics, and real-estate finance. A quick reference guide is included. Floppy disk, \$89.95. Howard W. Sams & Co. (see address above).

4Cast/1, a business-forecasting tool. This program is designed to save time and relieve you from the detailed statistical and mathematical aspects of forecasting using color graphics. Floppy disk, \$725. Heurix Computer Products, POB 9227, Morris-town, NJ 07960.

LOW PRICE

**SLIM TYPE & DIRECT DRIVE
5 1/4 Inch Mini Floppy Disk Drive
for AppleII & Iie**

APPLE II & Iie is a registered trademark of APPLE Computer, Inc.



**NF-555 SINGLE DRIVE
NF-556 DUAL DRIVE**



- ★Gone away Bogaa for seek Zero Track
- ★Using Direct drive Spindle moter

■FEATURES

- Fully compatible with AppleII and Iie computers
- Low profile, high performance
- Fast head seeking
- Stable SITL-IC for outstanding performance
- 40 tracks available

Dealer inquiries invited

NEWTECH Co., LTD.

2F, MARUZEN BLDG. 1-8-6, KANDA-SURUGADAI,
 CHIYODA-KU, TOKYO, JAPAN
 PHONE : (03)295-8577 TELEX : J33255 NEWTECH

Professional Software for the Software Professional

DMA products operate on
the full range of
Z80, 8086, 8088 processors,
including the IBM-PC

Here's what you can do!

Application Creation

FORMULA II™

The Application Creator

The first and only Application Creator—a do-it-yourself concept for office automation. FORMULA II lets you define your files, forms, menus, and reports—FORMULA II then creates your program. FORMULA II includes a Database manager with an English Query language and a Form/Report Creator with word processing features.

Communications

ASCOM™

ASCOM™ is the most versatile asynchronous communication package for microcomputers on the market. It features interactive, menu-driven, and batch operations; supports auto-answer and auto-dial modems; includes most popular protocols; provides network simulation; and many other options. Xerox Corporation, NCR, Monroe Systems for Business, and the big 8 accounting firms use ASCOM™.

SYNC/COM™—A bisynchronous communication package that will be configurable for a variety of systems and includes a flexible interface to the operating system.

TERMCOM™—A configurable terminal emulator allowing any personal computer to emulate almost any terminal. Available: January '84.

Utilities

EM80/86™

This software emulator lets you use eight bit software on sixteen bit microcomputers without hardware modifications.

The 8086 O.S. Converter™

CP to MS—Permits execution of Digital Research's CP/M-86 programs under Microsoft's MSDOS (or PCDOS).

MS to CP—Permits execution of MSDOS programs under CP/M-86.

UT-86™

This package of user-friendly utilities for the IBM Personal Computer and similar systems includes copying, directory sorting, patching, and a general purpose file print utility.

Coming Soon

DMA."C"™—A "C" language compiler which will generate either Z80 or 8086 assembly language code. Due to a unique optimization routine which is based upon a functional "P-code" model, the efficiency of DMA."C" will far exceed that of existing compilers.



WE SPEAK YOUR LANGUAGE WE SPEAK YOUR LANGUAGE WE SPEAK YOUR LANGUAGE

DYNAMIC MICROPROCESSOR ASSOCIATES, INC.

545 FIFTH AVENUE, NY, NY 10017

Dealer Inquiries only • (212) 687-7115

Software Received

Metafile, an integrated software system combining many facilities necessary for the development of applications or for impromptu information reporting. Floppy disk, \$1995. Sensor-based Systems, Olmsted Federal Building, Chatfield, MN 55923.

Novatron, a high-speed strategy game based on building walls to trap your opponent (the computer) or force it to crash into a wall before you do. Includes three levels of difficulty. Floppy disk, \$34.95. Fast-N-Fun Video, 1074 East Sandpiper Dr., Tempe, AZ 85283.

Novatron Trilogy, a series of three games. Construction is a game based on building walls to trap your opponent; Mazerace is a two-player race in which you avoid obstacles and exit before time runs out; and in Grid Walker you try to shoot your opponents

before being shot yourself. Floppy disk, \$29.95. Fast-N-Fun Video (see address above).

The 1 Dir, an interactive directory-command system that eliminates the need to type DOS commands and filenames on the command line. It is also designed so that the new user can begin taking advantage of the PC's power right-away, without requiring full knowledge of the DOS syntax. Floppy disk, \$95. Bourbaki Inc., POB 2867, Boise, ID 83701.

Project Planner II, a project-planning program capable of scheduling large-scale engineering projects. It can also handle small business applications that require bar charts. Floppy disk, \$110. Engineering Software, 120 Raven Crescent, Prince Rupert, British Columbia V8J 4C9, Canada.

Sandman Medical Office Management, a medical-accounting program for easy setup and maintenance of patients' records, charges, and payments. It offers reindexing of files and can print statements, insurance forms, and daily and monthly reports. Floppy disk, \$1000. Perceptions Inc., 17 Pine Lake Dr., Arab, AL 35016.

Schultz's Treasure, an animated adventure in three-dimensional color. You must enter the Lost Dutchman's Gold Mine and retrieve the Mother Lode without being killed. Floppy disk, \$34.95. Fast-N-Fun Video (see address above).

Tallymaster, an interactive financial-analysis program. Designed for personal and small business use, this program lets you easily summarize and analyze budgets and expenses. You can iden-

tify major categories of revenues, expenses, sales volumes, or manufacturing volumes or define up to 702 categories with names you select. Floppy disk, \$129.95. Prosoft, POB 560, North Hollywood, CA 91603.

Tutor-PC/Graphics, a graphics-instruction program designed to aid the user in understanding BASIC graphics capabilities. Statements included are screen, color, line, draw, preset, circle, and paint. Requires color-graphics card. Floppy disk, \$29.95. LDH Computing, POB 59-2982, Miami, FL 33159.

Ultralight Command, an arcade-type game. As Commander of a specially outfitted ultralight aircraft, you must defend unarmed supply boats. Your defenses include lasers and radar instruments. Floppy disk, \$39.95. Fast-N-Fun Video (see address above).

StarLogic Announces Savings on IBM PC Compatible Disk Drives Under 2.0 DOS

Internal 5 1/4" Floppy Drives

Standard-sized drive, plug compatible with IBM PC and IBM PC XT

Tandon single-sided drive—180K bytes \$165

Tandon double-sided drive—360K bytes \$235

Internal Half-Height 5 1/4" Floppy Drives

Single drive configuration double-sided drive 360K bytes \$225

Dual drive configuration two double-sided drive 720K bytes \$460

5 1/4" Winchester DiskSystems® From Interface Inc For Your IBM PC

Includes Winchester drive, cabinet, power supply, cable, controller, I/O adapter and device driver. Compatible with 2.0 DOS.

10 Megabyte formatted DiskSystem \$1375

15 Megabyte formatted DiskSystem \$1775

25 Megabyte formatted DiskSystem \$2175

5 1/4" Winchester Backup or Additional Storage For Your IBM PC XT or IBM PC DiskSystem.

Slave compatible with 2.0 DOS

10 Megabyte formatted storage \$1225

15 Megabyte formatted storage \$1425

25 Megabyte formatted storage \$1925

Telephone Orders Only
MasterCard, VISA or
Cashier's Check COD
(213) 883-0587

StarLogic

20932 Cantara Street
Canoga Park, CA 91301

IBM is a registered trademark of IBM Corporation
DiskSystems is copyrighted by Interface Inc
Prices are subject to change without notice

COMPUShACK™

PRICES AND AVAILABILITY SUBJECT TO CHANGE WITHOUT NOTICE
ALL RETURNED MERCHANDISE SUBJECT TO A 20% RESTOCKING FEE.

ADD 10% FOR NET TERMS

PRICES GOOD IN U.S. ONLY.

PRICES REFLECTED IN THIS SECTION ARE LOWER THAN FRANCHISE STORES.

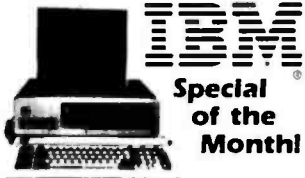

Special of the Month!

IBM PC- COMPLETE LINE

IBM
PC System includes 64K IBM-PC with 2. 320KB Floppy Drive Controller, Color Graphics Card, Monitor. All for only **\$2599.00**

LOTUS 1-2-3 SOFTWARE .. \$459

AST RESEARCH

IO Plus-Parallel & Serial Port, Clock Calendar W/Bat. back-up, Superdrive, Superspool **\$199.00**

Combo Plus- 256K, Parallel & Serial Port, Clock Calendar W/Bat. back-up, Superdrive, Superspool **\$499.00**

Mega Plus- 512K, Parallel & Serial Port, Clock Calendar W/Bat. back-up **\$999.00**

QUADRAM

Quad Board - 256K, Parallel Port, Serial I/O, Clock Calendar with battery backup **\$599.00**

512K Ram with Serial I/O **\$799.00**

HERCULES GRAPHICS CARD
This card gives you 720 x 350 graphics **\$499.00**

BIG BLUE **\$479.00**

MAYNARD SANDSTAR SERIES

Multifunction Card **\$95.00**

Floppy Disk Controller **\$225.00**

Memory Card **\$189.00**

Add-On Memory Module **\$99.00**

Parallel Port Module **\$75.00**

Serial Port Module **\$95.00**

Clock Calendar Module **\$75.00**

Games Adapter Module **\$59.00**

OTHER PRODUCTS FOR IBM

THE ULTIMATE SOLUTION TO THE PC EXPANSION DILEMMA FROM LNW COMPUTERS FOR YOUR IBMPC AND PCXT BUSBOARD "MOTHERBOARD".

Allows for addition of eleven (11) different modules and additional processing power through coprocessor BUS **\$349.95**

LNW80 CP/M PLUS®

COPROCESSOR MODULE. Z80A module runs CP/M® and CP/M PLUS® as well as CP/M 2.2 programs. For use in both 5" and 8" disk drives **\$249.95**

ASYNCHRONOUS COMMUNICATIONS I/O. Allows each Busboard to contain up to 8 separate serial asynchronous channels with a total of 15 different channels **\$79.95**

5" OR 8" FLOPPY DISK I/O MODULE. Replaces disk controller in PC and is compatible with diskettes from other CP/M 86® and CP/M® systems **\$169.95**

PARALLEL PRINTER I/O MODULE. Multi-user Printer port addressing, or general purpose 8-bit I/O port **\$49.95**

CLOCK CALENDAR I/O MODULE. Operates both CP/M 86® and MSDOS®. Also includes back-up battery and Alarm function **\$69.95**

GAME I/O MODULE. Compatible with IBM PC Game I/O card. Allows for connection of either 2 joysticks, or 4 paddles **\$49.95**

DIRECT-CONNECT MODEM I/O MODULE. Features answer/dial in tone or pulse for low cost long distance services. Program listing allows for smart modem under BASIC. Speed dialer program included **\$149.95**

A/D I/O MODULE. 16 independent multiplexed analog input channels w/8 bits of resolution per channel **\$109.95**

8 BIT I/O MODULE. Both latched 8 bits output and input with Interrupt capability fully supported. User programmable port addressing for up to 8 modules per Busboard **\$59.95**

PROTOTYPING I/O MODULE. Utilizes 3M Scotchflex Breadboard prototyping system. Complete with 40 conductor I/O BUS connector and an assortment of prototyping pins **\$29.95**

WORD PLUS-PC
Word Processing Software **\$299**

HARD DISK SYSTEMS FOR IBM AND APPLE

DAVONG FOR IBM	Internal	External
5MB	\$1495	\$1695
10MB	\$1795	\$1995
15MB	\$2295	\$2495
21MB	\$2595	\$2795
32MB	\$2995	\$3195

FLOPPY DISK DRIVES

SHUGART	
SA400 SS/DD	\$169.00
SA450 DS/DD	\$239.00
SA800/801 SS/DD	\$365.00
SA850/851 DS/DD	\$459.00

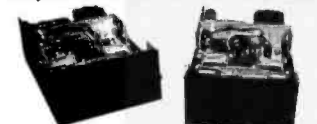

TANDEM	
TM-100-1 SS/DD	CALL
TM-100-2 DS/DD	CALL
TM-100-4 DS/DD	\$359.00
TM-848-1 SS/DD	\$425.00
TM-848-2 DS/DD	\$499.00

SIEMENS	
FDD 100-5	\$159.00
FDD 200-5	\$199.00

DISK DRIVES	
For IBM PC	
Tandon 100-2	CALL
Teac 55-B Simitri® 320KB	\$260
Shugart SA-455 Simitri 320KB	\$250

THE BUSINESS MANAGER Integrated Accounting System

The best and most complete business program package on the market. Providing all the software and storage you ever wanted. All software pre-installed on 10 or 15MB hard disk and ready to run. No more diskettes and tedious paper work. High speed. All programs self-prompting and menu driven. Fully guaranteed and supported. **Includes: General Ledger Accounts Receivable Accounts Payable Billing Inventory Payroll Word Processor Spelling Checker File Management Spreadsheet Database Management System** **CALL**

PRINTERS

TAVA PRINTERS BY DIABLO

DOT MATRIX PRINTERS
Model 11
80 Column/100 CPS **CALL**

Model 31
132 Column/100 CPS **CALL**

Model 32
132 Column/150 CPS **CALL**

Model 38
132 Column/400 CPS **CALL**

DAISY WHEEL PRINTERS

Model 620
132 Column/20CPS **CALL**

Model 630
API/40 CPS Letter Quality **CALL**

Model 630
ECS/API-40CPS **CALL**

Multi-Lingual **CALL**

Daisywriter Daisywheel

Printer **\$999.00**

NEC SPINWRITER

NEC

7710-1 **\$1995** 3510 **\$1395**

7715-1 **\$2195** 3515 **\$1395**

7730-1 **\$1995** 3530 **\$1595**

7720-1 **\$2595** 3550 **\$1895**

7725-1 **\$2595** PC8023A **\$ 495**

STAR MICRONICS

Gemini 10 **CALL**

Gemini 15 **CALL**

SMITH CORONA IBM

TP-1 parallel **\$579.00**

TP-1 serial **\$579.00**

C-170H

GX-100 (50 CPS Dot Matrix) **\$249.00**

8510 **\$469.00**

1550 (15") **\$699.00**

F-10 (40 CPS, Letter Qual.) **\$1395.00**

F-10 (55 CPS, Letter Qual.) **\$1695.00**

OKIDATA

82A **\$429.00**

83A **\$699.00**

84AP parallel **\$999.00**

84AS serial **\$1099.00**

92A **\$525.00**

93A **\$999.00**

IDS PRISM

Prism 132 (B & W) **\$1395.00**

Color **\$ 3 CALL**

BROTHER brother

HR-1 A parallel **\$769.00**

HR-1 A serial **\$869.00**

HR-15 **\$599.00**

Tractor feed option **\$135.00**

MONITORS

AVAILABLE [All Models] CALL

PRINCETON GRAPHIC SYSTEMS

Hls Res. Color **CALL**

APPLE IIe

Computer System, Controller, Two Disk Drives, Monitor **\$1890**

TAVA PLUS COMPUTER SYSTEM [APPLE II+ COMPATIBLE]

64K CPU Expandable to 128K 2 Disk Drives Controller Card Monitor, Parallel Port, Serial Port, 2 Game I/O's, CP/M® on board, DOS 3.5 **\$1299**

Apple II+ Compatible Computer System W/48K of memory. One "Data Drive" disk drive, Controller card, 12" green screen Hi-Resolution Monitor. All Cables are included for a CompuShack price of **\$999.00**

Additional Drive
With purchase of above System **\$100.00**

OTHER PRODUCTS FOR APPLE

Special of the Month \$259



100% Compatible Disk drive for APPLE II+ and APPLE IIe. Runs DOS, CPM®, Pascal software.

SLIMLINE DRIVE **\$269.00**

TAVA PRODUCTS FOR APPLE

Cooling System and

Power Monitor **\$59**

Joystick **\$49**

80 Column Card **\$149**

HAYES MICROCOMPUTER PRODUCTS

Micromodem II 300 baud **\$299.95**

Smartmodem 1200 baud **\$529.95**

PERSONAL ACCOUNTANT

Software for your Apple IIe and Apple II+ **\$199.00**

EPD PRODUCTS

Lemon Surge Protector **\$49.95**

Lime Surge Protector **\$79.95**

Peach Surge Protector **\$89.95**

Orange Surge Protector **\$129.95**

Plum Surge Protector **\$48.95**

DEC Rainbow 100

Keyboard, CPU, Z-80/8088, 64K, Serial RS232 Port, Two X-400KB Disk Drives, Monitor, CPM86®/80 Software. **CALL**

COMPUShACK

COMPUShACK FRANCHISES AVAILABLE

WHERE ELSE CAN YOU FIND PRIVATE LABEL PRODUCTS NO ROYALTIES DISCOUNT PRICES FULL SERVICE & SUPPORT?

ONLY AT COMPUShACK'S NEW FRANCHISE!

(714) 261-1000

FRANCHISE INQUIRIES WELCOME

16861 ARMSTRONG, IRVINE, CA 92714

HEADQUARTERS/TELEX: 181667-ANSWER BACK: COMPUShACK IRIN

ALL FLOPPIES REPAIRED QUICKLY AT LOW COST

FREE SHIPPING

IBM® P.C. Compatible Products

Davong 5 MB Hard Disk System - \$1495 / 12 MB - \$1995
Quadram - Quadboard with Parallel
 Port. Serial Port. Clock/Calendar. Expandable to 256K
 64K on brd - \$325 / 128K on brd - \$395 / 192K on brd - \$439 / 256K on brd - \$499

Quadchrome Monitor - \$575 - AST & Persyst Exp. Prod. \$ Call
 - Amdtek Monitors -
 Mod 300 Phosphor - \$150 Composite Color III - \$395
 IBM RGB Compatible Color II \$450 / Color I - \$325

- IBM/TRS 80 Disk Drives/Cabinets -
 TM 100 Single 40 Track Drive - \$189 TM 100-2 Double 40 Track Drive - \$280

Apple II® Computer Products

Apple Compatible Disk Controller \$85
 Apple Compatible Disk Drive w/Cabinet & Cable \$199 w/Controller \$259
TEAC Slim Line 5 1/4" Drive \$265 - Dual Slim Line \$525
 Grappler Printer Interface \$139 - w/16K Buffer \$210
Davong 5 MB Hard Disk System - \$1495 - 12 MB - \$1995
 -Epson/Smith-Corona Printers -



RX80 \$425 FX80 \$550 FX100 \$685
 TRS 80 / Parallel Printer Cable \$ 20
 IBM Parallel Printer Cable \$ 35
STAR MICRONICS GEMINI 10X \$325
GEMINI 15 \$459
 Smith Corona TP-1 Letter Quality Daisy Wheel \$519

Power Supplies
 And Cabinets

Dual 8" Slim Line - \$180 Dual 5 1/4" - \$89
 Single 5 1/4" - \$65

VISA, MASTERCARD (\$100 Min., Add 2%) Or
 Certified Check. Ninety Day Warranty
 (Parts & Labor) TRS is a Registered Trademark.
 Tandy Corp. Prices Subject to Change
 Without Notice. **FREE SHIPPING IN**
CONTINENTAL U.S. (TRS MOD II EXCEPTED)
 (213) 993-4804

DATA-MAIL

P.O. Box 818 Reseda
 Calif 91335
1-800-635-5555

PORTABLE 68000 ASSEMBLER

MOTOROLA SYNTAX MACROS
LINKER CONDITIONALS
OBJECT LIBRARIAN
CROSS REFERENCE
STRUCTURED PROGRAMMING FEATURES

OBJECT CODE OPTIMIZED
FOR CP/M-80, CP/M-68K | **\$300**
OR IBM-PC

PORTABLE C SOURCE | **\$750**

Quelo
 843 NW 54th
 Seattle, WA 98107

(206) 784-8018
 mornings
 Dick Curtiss

CP/M is a trademark of Digital Research
 IBM-PC is a trademark of IBM

Software Received

VIS/Bridge/REPORT, a package that enhances the printing capabilities of Visicalc. This program allows you to print variable column widths, align decimal points, justify numbers within a column, and automatically format reports to fit space requirements. Floppy disk, \$79. Solutions Inc., POB 989, Montpelier, VT 05602.

The Drawing Board, a graphics-drawing program. Using commands from the keyboard, you can clear or invert the screen, print screen to printer, save and load picture to or from tape, disk, or memory. You can draw pre-programmed shapes, type text on the screen, draw lines from point to point, and fill in shapes. For Models I and III; cassette, \$20. Larsen Co., 115 Bixby Dr., Milpitas, CA 95035.

TRS-80

Airstrike, a war-simulation game similar to those played by students in major military academies. You use combat task forces and weapons against various targets and target systems. To create realistic combat scenarios, tactical concepts such as air superiority, interdiction, close air support, and reconnaissance are included. For Models I and III; floppy disk, \$29.95. Atron International, POB 8825, Fort Collins, CO 80525.

Planets, an educational program that teaches astronomy by giving the location of planets, phases of the moon, and dates of meteor showers. The program can map out any location of the universe you choose. For the Color Computer; cassette, \$6. Moses Engineering, POB 11038, Ardmore Highway Station, Huntsville, AL 35805.

Bible Games—1, two educational games. Concentration tests your ability to match Biblical names or concepts. Biblical Fortunes tests your knowledge of names, events, phrases, and places in the Bible by presenting them one letter at a time. For Models I and III; cassette, \$9.95. R & M Enterprises Software, 107 Peachtree St., POB 543, Elizabethtown, KY 42701.

User Communication Utility, a utility designed to allow a program to interact with a remote terminal, host computer, or other RS-232C-compatible devices such as a bar-code scanner. This gives users program control over messages transmitted and received. For the Model II; floppy disk, \$85. Micro Design Computer Systems, 1325 South Falcon, Anaheim, CA 92804.

Casino Black Jack, a graphics simulation of the card game blackjack. Up to seven players can ask for advice from the computer, shuffle and cut the deck, and see each player's and the house's accumulative profit or loss on screen. For the Model III; cassette, \$19.50. Lillian G. Choi, 82 Nicholas Dr., Bristol, CT 06010.

VIS/Bridge/GL, a utility package that lets you make projections with Visicalc based on General Ledger data without having to reenter data it already has. You can project financial data using Visicalc and compare your projections to actual results. For Models II, 12, and 16; floppy disk, \$195. Solutions Inc., POB 989, Montpelier, VT 05602.



step into the future ... *COHERENT*[™]

COHERENT[™] is the most powerful UNIX[™]-compatible operating system available for the IBM PC[™], IBM XT[™] and compatibles.

Now you can have the multi-user, multitasking programming capability of a mainframe on a microcomputer. The UNIX-like environment of COHERENT lets you take C code developed using UNIX V7 system utilities and compile and run it on the IBM PC. Through COHERENT'S highly-optimized kernel you can access over 145 different commands including a C-compiler, a text-formatter and LEX and YACC.

Hard disk support presently includes the IBM XT, Genie (removable cartridge), Corona, Davong,

Corvus and Tecmar. Memory cards supported include the AST Megaplus (with or without clock), the Tecmar multifunction board and Tall Tree Systems (512K byte) JRAM cards. Support for more devices and more IBM PC compatibles will be available by the time this ad appears.

The cost of all this — far less than the cost of similar UNIX-based operating systems. Remember, when you buy COHERENT from NCI you receive all the documentation and technical support you need to operate it.

For more information call or write:



**Network Consulting Inc.
Discovery Park,
3700 Gilmore Way, Suite 110,
Burnaby, B.C. Canada V5G 4M1
(604) 430-3466**

COHERENT is a trade mark of Mark Williams Co. UNIX is a trade mark of Bell Laboratories. IBM PC and IBM XT are trade marks of International Business Machines Corporation.

PC Tech

BUSINESS & HOME COMPUTERS
Products Sales & Services

We Shop The Wholesale Market And Negotiate The Best Price For You.
We Save You Off The List Price. We Share A Common Goal - To Save You Money.

NEC APC 8800 Systems call for best price	
Apple II Compatible Drives	
Mitac Standard Size	\$219.00
Super 5-A40 H/H	\$229.00
Super 5-T40 H/H	\$239.00
W/Ctr.	\$299.00
Super 5-T80	\$349.00
Direct Shaft Drive	
W/Controller	\$399.00
Controller Card	\$69.00
16K Memory Card	\$59.00
Z80 Card	\$109.00
80 Column Card	\$115.00
*IBM-PC Compatible Drives	
Super 5-IT80 H/H	\$249.00
Super 5-IP80 H/H	\$239.00
Corvus Dk. Sys. 6 MB	\$1539.00
Corvus Dk. Sys. 11 MB	\$2139.00
Corvus Dk. Sys. 20 MB	\$2889.00
*MODEM (Hayes)	
Smartmodem 1200	\$499.00
Smartmodem 1200B	\$439.00
Micromodem II	\$279.00
Micromodem II/Trm. Prg.	\$299.00
*MAYNARD ELECTRONICS	
Floppy Disk Controller	\$169.00
FDC W/Parallel Port	\$219.00
FDC W/Serial Port	\$229.00
Memory Card W/256K RAM	\$489.00
*Corona 128K Desk-top Complete System	\$2399.00
*PRINTERS	
BROTHER D/W	
HR-1A P	\$739.00
HR-1A S	\$839.00
HR-15	\$529.00
Tractor	\$129.00
Okidata ML-80	\$369.00
Okidata ML-92P	\$519.00
Okidata 93	\$849.00
Daisywriter W/48K Butler	\$999.00
Juki	\$599.00
Gemini 10	\$359.00
Gemini 10X 120 CPS	\$449.00
Gemini 15	\$539.00
Super 5-CP80	\$359.00
*MONITORS	
BMC BM-12 AU 12" Green	\$89.00
BMC BM-12 AU 12" Amber	\$99.00
BMC BM-1401RGB W/Cd Cbl	\$399.00
DYNAX GM-120 GM 12"	\$139.00
DYNAX AM-121 AM 12"	\$149.00
TAXAN KG-12N 12" Green	\$139.00
TAXAN KG-12N 12" Amber	\$149.00
TAXAN RGB 1 12"	\$339.00
AMDEX 12" Green #300	\$159.00
AMDEX 12" Amber #300	\$159.00
Business Software:	
Software Dimensions.	
Peachtree + more...	
Games: Sierra On-Line	
Broderbund + more Many More Not Listed	

PC Tech (714) 546-3887

3742 W. Warner Ave., Santa Ana, CA 92704

Disc Drive Service Available At Low Cost - Quick Turn-around

ADD SHIPPING CHARGES

Telephone or Mail Orders Please - Cashier's Checks, Money Orders, Checks (Allow 10 days).
COD Accepted - CA Residents Add 6% Sales Tax. Prices Subject To Change Without Notice.

Software Received

Texas Instruments

Bionic Bunny, an arcade-type game that is similar to Donkey Kong. Requires Extended BASIC. For the 99/4A; cassette, \$15. Softwar III, 1307 Douglas Dr., Sterling, IL 61081.

Caterpillar, a fast-action non-violent game. It runs in BASIC or Extended BASIC for faster action. For the 99/4A; cassette, \$10.50. The Softies, Suite 229, 7300 Gallagher Dr., Edina, MN 55435.

Crillion Defender, an arcade-type game. You must protect Crill from the invading alien ships on a star map and in three-dimensional space-combat sequences. Requires Extended BASIC. For the 99/4A; cassette, \$14.95. Greene-Bytes, POB 329, Waynesburg, PA 15370.

TI Res, a high-resolution plotting subroutine that lets you draw on a 196 by 256 pixel (picture element) screen. Requires Extended BASIC. For the 99/4A; cassette, \$15. Softwar III (see address above).

ZX81/T/S 1000

Disassembler, a flexible utility package that lets you examine machine-code programs as mnemonics rather than just sequences of numbers. It can also display hexadecimal data and equivalent characters. Cassette, \$14.95. Scientific Software, 6 West 61

Terrace, Kansas City, MO 64113.

Screen Machine, a utility package that provides a way of placing input prompts and response fields where you need them on the screen. This removes the limitations of the original input schemes. Cassette, \$14.95. Syncmaster, POB 511, Oak Ridge, NC 27310.

Vu-Write, a word processor designed to provide an easy method of entering, changing, storing, and saving text. You can document programs and spreadsheets or write letters and newsletter columns. Cassette, \$14.95. Syncmaster (see address above).

Other Computers

Number Cruncher, a financial-analysis and projection system that lets you create your own spreadsheet. Produce sophisticated reports that combine word-processing, spreadsheet, and information-management functions using simple English. For the DECmate; floppy disk, \$400. Pyramid Data Ltd., POB 10116, Santa Ana, CA 92711.

White Water, seven adventure games. Shoot the rapids of the raging river for your best time or navigate the river to dock and collect treasures in the forest. For the Mattel Intellivision; cartridge, \$39.95. Imagic, 981 University Ave., Los Gatos, CA 95030. ■

This is a list of software packages that have been received by BYTE Publications during the past month. The list is correct to the best of our knowledge, but it is not meant to be a full description of the product or the forms in which the product is available. In particular, some packages may be sold for several machines or in both cassette and floppy-disk format; the product listed here is the version received by BYTE Publications.

DECADES OF SERVICE

Washington Computer Services

97 Spring St., New York, NY 10012 an affiliate of WASHINGTON ELECTRIC COMPANY est. 1912

TO ORDER: Call our toll-free number: (800) 221-5416. In N.Y. State and for technical information: (212) 226-2121. Hours: 9 AM-5:30 PM (EST) Monday-Friday TELEX: 12-5606 CABLE: WASHCOMP NYK

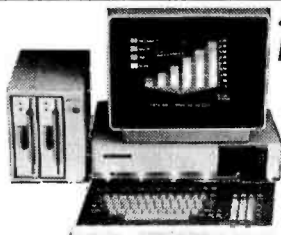

NEC PC-8800

- INCLUDES:**
- CP/M
 - N-BASIC-80, 88
 - WORDSTAR
 - MULTIPLAN
 - HIGH RES. (640x400) CAD/CAM GRAPHICS
 - MONOCHROME & RGB COLOR
 - 5 1/4" & 8" DISK DRIVES

- OPTIONAL:**
- 8 Mhz 8086, 16 BIT
 - HARD DISK DRIVE
 - SPEECH SYNTH. & RECOC.
 - LIGHT PEN

The Professional's Workstation

We feel that this uniquely flexible graphics work station offers a most cost effective microcomputer solution.

Please call for prices and a demonstration.

NEC on GSA Contract #G500K830156035

PLEASE! Do not confuse us with mail order dealers. We are a full service distributor serving the data processing & installation needs of business & industry from micros to mainframes. System houses, educational institutions & governmental agencies given special consideration. Leasing available. N.Y. State agencies, municipalities, and schools—call us for information on our O.G.S. term contracts on hardware & software.

DEALER and INTERNATIONAL INQUIRIES WELCOME

Please call to make an appointment for demonstration of this extraordinary computer at our showroom. Prices subject to change without notice. call for latest prices. Prices include 3% cash discount. N.Y. residents add sales tax. CP/M® is a trademark of Digital Research. All sales subject to our standard sale conditions (available on request). Above prices do not include customization or installation.

PUT PRICES IN CHECK

CARTRIDGE RIBBONS FOR
APPLE PRINTERS
 NEC 8023A
 C. ITOH PROWRITER

\$7.99 EA. **\$86.29** DOZ.

CARTRIDGE RIBBONS FOR
EPSON
 MX-80 MX-100

\$6.99 EA. **\$9.95** EA.
\$75.49 DOZ. **\$107.46** DOZ.

MAXELL
DISKETTES
 5 1/4" SINGLE SIDE
 DUAL DENSITY
 MD-1

\$29.90 10 PACK

INNOVATIVE
 CONCEPTS
FLIP'N'FILE
 DISC STORAGE BOX
 HOLDS UP TO 60 DISKETTES

5 1/4" 8"

\$24.95 EA **\$29.95** EA

RIBBONS FOR
IDS PRINTERS

	EA.	DOZ.
440	\$2.75	\$29.70
PAPER TIGER	6.95	75.06
MICROPRISM	7.99	86.29
PRISM	10.95	118.25

DISKETTE
STORAGE
BOXES
 5 1/4" — BLUE OR BEIGE

\$2.49 EA.

DUAL SPOOL RIBBONS FOR
OKIDATA
PRINTERS

80, 82, 83	EA.	DOZ.
92, 93	\$2.75	\$29.70
84	5.99	64.69

MEMOREX
DISKETTES
 5 1/4" SINGLE SIDE - DUAL DENSITY

\$24.99 10 PACK

COLOR-
CODER
LIBRARY CASE SET
 CONTAINS 5 BRIGHT COLORS

5 1/4"	8"
\$19.95 SET OF 5	\$23.95 SET OF 5

WABASH
DISKETTES
 5 1/4" SINGLE-SIDE SINGLE DENSITY

10 FOR \$19.99
 WITH FREE
LIBRARY CASE!
 SPECIFY BLUE OR BEIGE

PROTECTALL
LINE VOLTAGE
SURGE
SUPPRESSOR
 (SIX OUTLET)

\$39.95 EA

LABEL
SPECIAL

\$2.99 / K
 (5K MIN)

1 ACROSS 3 1/2 x 15/16 CONTINUOUS LABELS

MOST RIBBONS AVAILABLE IN COLORS TOO!
 CALL OR WRITE FOR OUR SUPPLIES CATALOGUE
 ON ORDERS UNDER \$14.00 PLEASE ADD \$3.00 FOR SHIPPING
 MINIMUM RIBBON ORDER \$30.00 OR 1 DOZEN

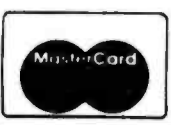

Check-Mate™

TOLL FREE 800-343-7706
 IN MASS 617-963-7694
 PHONES OPEN 9AM-6PM EASTERN TIME

51 DIAUTO DR. P.O. BOX 103
 RANDOLPH, MA 02368

MASS RESIDENTS
 ADD 5% SALES TAX

Circle 81 on inquiry card.

BYTE October 1983 565

Clubs and Newsletters

Israeli Computerists

The Israel Microcomputer Users Group (IMUG) in Tel Aviv comprises users, owners, and retailers of all brands of microcomputers who want to establish worldwide contact with other users groups and exchange newsletters. A newsletter, *The Microcomputer Age*, is produced each month and meetings are held regularly in Jerusalem. Membership is 350 shekels. For information, contact the Israel Microcomputer Users Group, POB 45030, Tel Aviv 61450, Israel.

Computers In Business

The Connecticut CP/M Users Group welcomes anyone interested in business and professional applications of microcomputers to attend nontechnical meetings held on the last Monday of the month at 7 p.m. in the McCook Auditorium of Trinity College in Hartford, Connecticut. For information, contact Malcolm Roth, 62 Burnwood Dr., Bloomfield, CT 06002, (203) 243-3063 evenings.

IBM PC Users Form Texas Club

The North Texas IBM Personal Computer Users Group is a nonprofit, independent group that focuses on the uses of computers in industry and the home. It meets on the third Saturday of each month at 9:30 a.m. in the Heroy Building on the Southern Methodist University campus in Dallas. A regular membership is \$24, students are \$12, and a professional membership is \$36 a year. For details, contact John Pribyl, 2025 Rock Creek Dr., Arlington, TX 76010, (817) 275-4109.

California FIG

The FORTH Interest Group (FIG) is a worldwide organization that produces *FORTH Dimensions*, a bimonthly nonprofit publication that has a variety of articles on the applications of FORTH. New members are welcome. For information, contact the FORTH Interest Group, POB 1105, San Carlos, CA 94070, or call the FIG hot line at (415) 962-8653.

Chaos under Control

The Capitol Hill Atari Owners' Society (CHAOS) of Lansing, Michigan, produces a newsletter, *CONTROL*, that informs members about club activities. Both members and nonmembers can acquire disks from the club-maintained public-domain Atari software collection. Membership dues are \$20 a year. For details, contact CHAOS, POB 16132, Lansing, MI 48901.

A-BUG In Boston

The Atari Boston Users Group (A-BUG), an affiliate of the Boston Computer Society (BCS), produces a monthly newsletter, *A-BUG*, that is free to members of the BCS or to those willing to exchange newsletters about the Atari. For details, contact the Boston Computer Society, Atari Boston Users Group, Three Center Plaza, Boston, MA 02108, (617) 367-8080.

For Programming

The *PPC Calculator Journal* is the monthly publication of PPC, a nonprofit public-benefit corporation in California dedicated to serving people in personal computing. The

journal disseminates information related to the selection, evaluation, care, and applications of personal computers. Address inquiries to PPC, 2545 West Camden Place, Santa Ana, CA 92704, or call (714) 754-6226 evenings.

News for Veterinarians

A monthly newsletter for veterinarians, *Veterinary Computing*, covers computer applications in veterinary medicine. Subscriptions are \$42 per year. Further information is available from American Veterinary Publications, PO Drawer KK, Santa Barbara, CA 93102.

SIGAIR In Toronto

A special interest group on artificial intelligence and robotics (SIGAIR) has been formed in Canada. Meetings are held on the first Friday of each month in the Toronto area. Anyone interested is welcome to attend. For information, write to SIGAIR, POB 874, Postal Station P, Toronto, Ontario M5S 2Z2, Canada.

Wisconsin Explorers

The Explorer-85 Users Group is for people who are interested in Netronics Explorer-85 equipment. A newsletter, *Explorations*, is produced. For more details, write to the Explorer-85 Users Group, 3430 93rd St., Sturtevant, WI 53177, or call Clarence Heier at (414) 886-1704.

Canadian COMIC

The Co-operators Microcomputer Club (COMIC) seeks communication with

other IBM Personal Computer users groups. A newsletter may be produced. Contact the club through Adrian Groendyk, The Co-operators, 1920 College Ave., Regina, Saskatchewan S4P 1C4, Canada.

Free to SAS Users

Users of SAS (Statistical Analysis Systems) mainframes can join SUGI (SAS Users Group International) and receive the free quarterly newsletter, *SUGI SIG/M*. A \$2 annual donation is requested to cover printing and mailing costs. For a subscription or information, contact Jeff Bass, Bass Cybernetic Labs, RR 1, Box 124-B, Pittsboro, NC 27312.

A Graphics Update

The *S. Klein Newsletter on Computer Graphics* is produced twice a month by Technology & Business Communications Inc. It includes news that interprets significant developments in computer graphics including CAD/CAM, business graphics, and image processing. An annual subscription is \$155 and includes a directory of hardware and software suppliers for computer graphics. The newsletter is also available to subscribers via Newsnet. For details, contact the *S. Klein Newsletter*, 730 Boston Post Rd., POB 89, Sudbury, MA 01776, (617) 443-4671.

News for Mental Health Workers

Each issue of *Computers in Psychiatry/Psychology* contains articles, reviews, a calendar of events, and a bibliography on hardware and soft-

**AN ACCOMPLISHED PERFORMER
AT AN ENTRY LEVEL PRICE.**

BMC



BMC now offers you a dot matrix printer that delivers sophisticated features margin to margin. The BX-80 prints bi-directional in 40, 80, 71, or 142 columns in normal, double width or compressed text. And you can mix these in any line or print. You can also do superscript as well as superb graphics in character or bit image. And the BX-80 does all this with a changeable print head that delivers up to 30 million characters, with true descenders. The BX-80 gives you an integrated friction feed with built in sprocket tractor that adjusts to fit any size paper up to 10 inches in width.

Other features such as programmable line spacing, strobe pulse synchronization and TTL level technology are part of the BMC tradition of performance and reliability at an affordable price.

Circle #65 Dealers. Circle #66 End-users.



Setting the Standard in Performance and Price

CALIFORNIA

16830 S. Avalon Blvd., Carson, CA 90746

Telex: 664258 BMC GDNA

Phone: (213) 515-6005

NEW YORK

450 Barell Ave., Carlstadt, NJ 07074

Phone: (201) 939-7079

TOLL FREE: 1 (800) 752-5002

PROGRAMMING IN C ?

BE SURE YOU GET ALL THE PHACT's !

base your C programming on
PHACT-dbrm
 a multi-keyed (I S A M)
 Data Base Record Manager.

PHACT-dbrm
 is an easy to use library of C callable
 functions for manipulation of records in
 a database, plus high level database
 manipulation tools.

PHACT-dbrm
 supports: data dictionary; 5 datatypes; variable
 length records; full database security; database
 locking, data portability; ".h" file creation and
 much much more!

PHACT-dbrm
 runs on: all UNIX systems • IDRIS and UNIX look-
 alikes • MSDOS • CP/M

PHACT-rql (Relational Query Language) **PHACT-rg**
 (Report Generator) and **PHACT-rsg** (Relational Screen Generator)
 under development.

PHACT-dbrm
 is priced between \$250-\$950. (Source available)



To get all the PHACT's call DAVID GRAHAM at
PHACT ASSOCIATES Ltd • 212 • 420-1512
 231 EAST 11 STREET • NEW YORK • NY 10003

Clubs and Newsletters

ware for use in the mental-
 health profession. This clinical-resource newsletter covers
 applications of computers in
 such areas as neuropsychiatric
 and MMPI testing, EEG analysis,
 and office-management
 functions. Subscriptions are
 \$40. Volumes from the pre-
 vious five years are available.
 For information, write to
Computers in Psychiatry/Psychology,
 26 Trumbull St.,
 New Haven, CT 06511.

For IBM PC Users In Winnipeg, Canada

The IBM PC Users Group
 of Winnipeg meets on the
 third Thursday of each month
 and produces a monthly
 newsletter that contains
 minutes of the preceding
 meetings and other information.
 A regular membership is
 \$20; a junior membership is
 \$12 for people under 18 years
 old; and a family membership
 is \$25. Newsletter exchanges
 are welcome. For further
 details, contact the IBM PC
 Users Group of Winnipeg, c/o
 Business Development Inter-
 national, POB 5, Station A,
 Winnipeg, Manitoba R3K
 1Z9, Canada, or call (204)
 837-8509.

Atari Users In New Orleans

The New Orleans Atari
 Users Group (NOAUG) pro-
 duces a newsletter that con-
 tains reviews, features, and
 random bits of information.
 Meetings are held every other
 Wednesday. For further in-
 formation, contact NOAUG,
 8223 Plum St., New Orleans,
 LA 70118, or call (504)
 861-8772.

Sanyo Users Forum

The Sanyo Users Group
 (SUG/USA) provides infor-
 mation on the use of Sanyo
 computers, new products, and
 distribution of CP/M users-
 group disks in Sanyo formats.
 A quarterly newsletter is pro-
 duced. A \$10 annual member-
 ship includes access to a soft-
 ware library. For information,
 contact the Sanyo Users
 Group—U.S.A., 160 Emeline
 St., Providence, RI 02906.

Medical/Computer Clearinghouse

A newsletter for physicians
 devoted to such applications
 of computers as patient care
 and continuing education also
 updates key hardware, re-
 views, software, and contains
 the latest on medical net-
 works. The *Physician Com-
 puter Monthly* is written in
 nontechnical language for the
 novice as well as the experi-
 enced user. Subscriptions are
 \$95. For a free issue, send a re-
 quest on letterhead to Amer-
 ican Health Consultants, 67
 Peachtree Park Dr., Atlanta,
 GA 30309.

Computer Federation

The Computer Users Feder-
 ation (CUF) of Southeastern
 Wisconsin coordinates regional
 activities of mutual interest
 for users groups and clubs in
 personal computing. An area
 club directory and an annual
 computer fair are planned.
 The group produces a quarter-
 ly newsletter. For details, con-
 tact Computer Users Federa-
 tion, POB 23483, Milwaukee,
 WI 53223. ■

If you would like BYTE readers to know about your club or
 newsletter send the details accompanied by no more than one
 newsletter to Clubs and Newsletters, BYTE Publications, POB 372,
 Hancock, NH 03449. Overseas groups are encouraged to par-
 ticipate. Please allow at least three months for your announce-
 ment to appear.

NEW

**Announcing
 a solution to the most
 common computer
 problem.**

(Where to put the equipment.)



\$129.95
 RETAIL

Monitor Mover. You won't have to buy
 any expensive new furniture. You won't lose
 any desk space. Monitor Mover adjusts in four
 ways to each individual user while keeping the
 monitor (and system, if necessary) completely
 off your existing work space. Available for most
 popular brands of computer monitors.

Lintek |||||
 Computer Accessories

Dealer inquiries
 welcome.

PO. Box 8056, Grand Rapids, MI 49508 (616) 241-4040

Pro-Net™ System

Professional Local Area Network

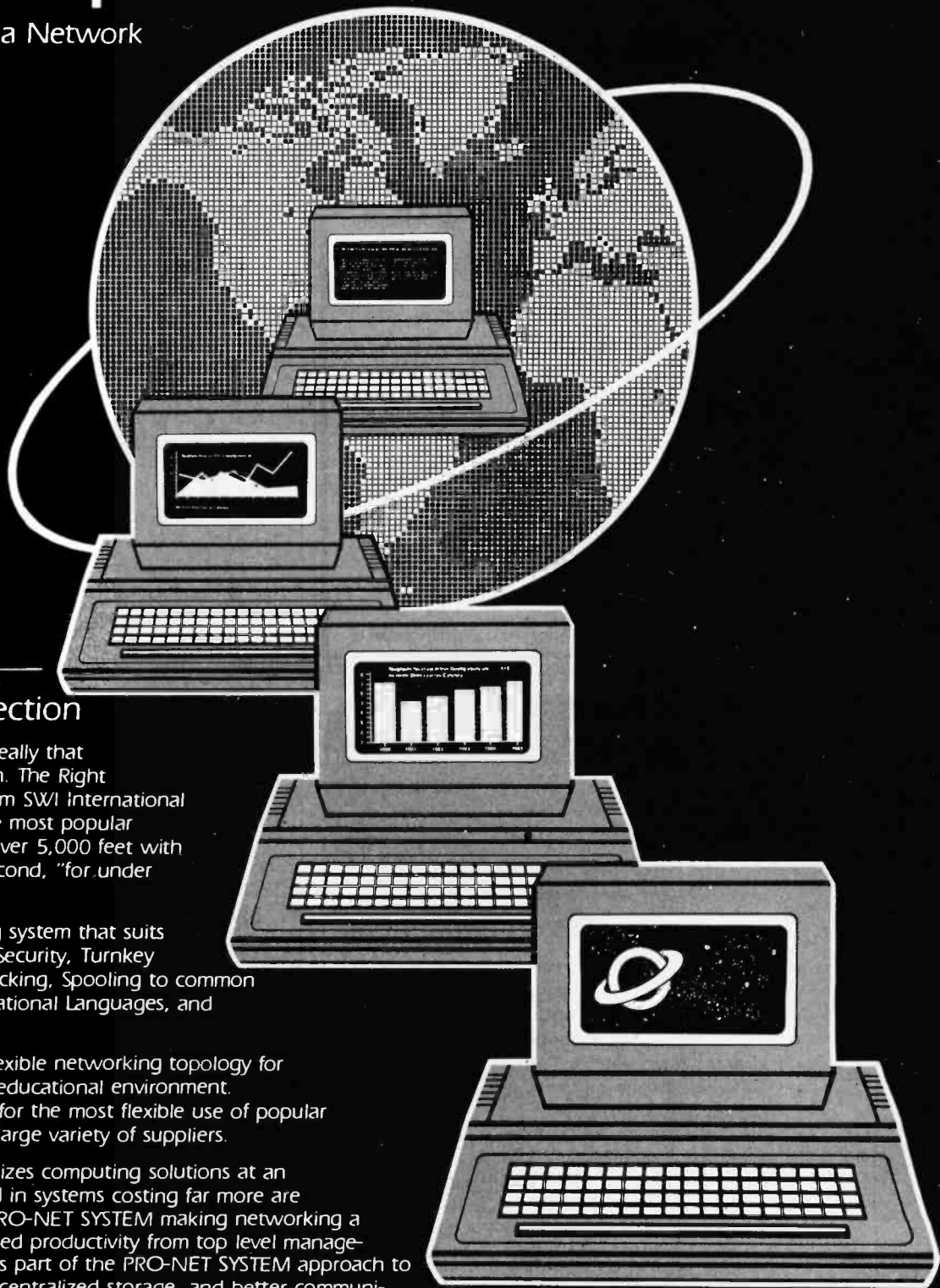

What's Your Connection

Being well connected is not Really that Difficult! Make the Connection. The Right Connection. The PRO-NET from SWI International Systems, links up to 128 of the most popular microcomputers at distances over 5,000 feet with speeds at 4 million bits per second, "for under \$300.00 per computer."

Select the multi-user operating system that suits you best, featuring Password Security, Turnkey Command, File and Record Locking, Spooling to common Printers, Electronic Mail, Educational Languages, and more...much more.

Take advantage of the most flexible networking topology for your business, professional or educational environment. PRO-NET SYSTEM also allows for the most flexible use of popular mass storage available from a large variety of suppliers.

The PRO-NET SYSTEM emphasizes computing solutions at an affordable cost. Features found in systems costing far more are standard components of the PRO-NET SYSTEM making networking a cost-effective necessity. Increased productivity from top level management to the department level is part of the PRO-NET SYSTEM approach to distributed computing power, centralized storage, and better communications. The PRO-NET SYSTEM provides the missing element to make your personal computer a versatile distributed networking communication solution.

SWI INTERNATIONAL SYSTEMS™

Specialist in Networking
For Microcomputers

See the PRO-NET SYSTEM at your local SWI INTERNATIONAL SYSTEMS dealer.

7741 East Gray Road, Suite 2 • Scottsdale, Arizona 85260-3496 • 602 998-3986 Telex: 467580

Circle 452 on Inquiry card.

De Smet C

PCDOS — CP/M-86 — MPM-86 — CCP/M-86

\$ 109

■ OUTSTANDING PRICE/PERFORMANCE

"SIEVE" Benchmark

135 bytes compiled — 6144 bytes linked
65 sec. compile (disk) — 11.5 sec. run (10 iterations)

■ FULL DEVELOPMENT PACKAGE

C Compiler, Assembler, Linker, Librarian and Full Screen Editor • Native 2.0 Support

■ COMPLETE IMPLEMENTATION

FULL K & R — plus — STUDIO LIBRARY
Both 8087 and Software Floating Point

To order specify OS & DISK SIZE/FORMAT.
Calif. residents add 6½% sales tax.

C WARE

1607 NEW BRUNSWICK SUNNYVALE, CA 94087

(408) 736-6905

PCDOS Trademark IBM — CP/M Trademark Digital Research

Peripheral Networking Now

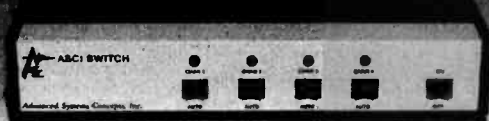

Buy ASCII Intelligent Port Expanders

- Eliminate Manual Switching by Remote Control
- Improve Productivity and Reliability
- Share Printers, Modems or Plotters
- Expand Computers or Terminals
- Use Matrix Switching for Multiple Transmission or Security
- Supports Polling and Queuing

INSTANT COMPATIBILITY with new computer devices and MAJOR OEM PRODUCTS:

Altos — Burroughs — Data General — DEC
H.P. — IBM — NCR — Northstar — Victor
and other key manufacturers.

Call 213-793-8979 TO EXPAND YOUR SYSTEMS TODAY.



Advanced Systems Concepts Inc.

435 N. Lake Ave., Dept. B10

Pasadena, CA 91101

800-824-7080 Telex: 701 215

Books Received

The ABCs of Microcomputers: A Computer Literacy Primer, Linda Gail Christie and Jess W. Curry Jr. Englewood Cliffs, NJ: Prentice-Hall, 1983; 228 pages, 15.3 by 22.8 cm, softcover, ISBN 0-13-000612-2, \$7.95.

The Apple II Circuit Description, Winston D. Gayler. Indianapolis, IN: Howard W. Sams & Co., 1983; 174 pages, 23 by 28 cm, spiral-bound, ISBN 0-672-21959-X, \$22.95.

Atari BASIC, Richard Haskell. Englewood Cliffs, NJ: Prentice-Hall, 1983; 192 pages, 21.5 by 27.8 cm, softcover, ISBN 0-13-049791-6, \$13.95.

BASIC: An Introduction to Computer Programming with the Apple, Robert J. Bent and George C. Sethares. Monterey, CA: Brooks/Cole Publishing, 1983; 368 pages, 21.5 by 27.8 cm, softcover, ISBN 0-534-01370-8, \$17.95.

BASIC Programming for the Classroom Teacher, Joan M. Miller, Ruth King Chaya, and Debra J. Santora. New York: Teacher's College Press (1234 Amsterdam Ave.), 1982; 288 pages, 24.8 by 17.5 cm, spiral-bound, ISBN 0-8077-2728-8, \$15.95.

Bola Glossary of Electronic Data Processing and Computer Terms, English-Spanish & Spanish-English, vol. 1. Hesperia, CA: Bola Publications (8769 Devon Ave.), 1982; 218 pages, 21.5 by 28 cm, softcover, ISBN 0-943118-00-X, \$29.95.

C Programming Guide, Jack Purdum. Indianapolis, IN: Que Corp., 1983; 272 pages, 23.5 by 18.8 cm, softcover, ISBN 0-88022-022-8, \$17.95.

Communications Software for Microcomputers, Janet L. Bruman. San Jose, CA: CLASS, 1983; 25 pages, 21.5 by 27.8 cm, softcover, ISBN 0-938098-01-2, \$12.50.

The Complete Book of Word Processing and Business Graphics, Walter Sikonowiz. Engle-

wood Cliffs, NJ: Prentice-Hall, 1982; 216 pages, 15.3 by 22.8 cm, softcover, ISBN 0-13-158659-9, \$14.95.

The Computer Cookbook, William Bates. Englewood Cliffs, NJ: Prentice-Hall, 1983; 384 pages, 21.5 by 27.8 cm, softcover, ISBN 0-13-165167-6, \$12.95.

Computer Keyboarding, Touch-Type to High Data Entry Speed, Frank P. Donnelly. New York: Dictation Disc Co. (240 Madison Ave.), 1982; 33 pages, 21.5 by 28 cm, spiral-bound, ISBN none, \$7.50.

Critical Issues in Software, Werner L. Frank. New York: John Wiley & Sons, 272 pages, 16.5 by 24 cm, hardcover, ISBN 0-471-87293-8, \$25.

Document Preparation Systems, J. Nievergelt, G. Coray, J. D. Nicoud, and A. C. Shaw, eds. Amsterdam, The Netherlands and New York: North-Holland Publishing Co., 1982; 288 pages, 15.5 by 23 cm, hardcover, ISBN 0-444-86493-8, \$46.50.

The Elementary Commodore 64, William B. Sanders. Chatsworth, CA: Datamost (8943 Fullbright Ave.), 1983; 224 pages, 12.5 by 20.5 cm, spiral-bound, ISBN 0-88190-001-X, \$14.95.

The Fast Track to the Top Jobs in Computer Careers, Peter Muller. New York: Perigee Books, 1983; 128 pages, 13.8 by 20.5 cm, softcover, ISBN 0-399-50753-1, \$4.95.

The Fast Track to the Top Jobs in Engineering Careers, Peter Muller. New York: Perigee Books, 1983; 128 pages, 13.8 by 20.5 cm, softcover, ISBN 0-399-50754-X, \$4.95.

Fortran 77, A Top Down Approach, Nonna Kliss Lehmkuhl. New York: Macmillan Publishing Co., 1983; 480 pages, 17.5 by 25.5 cm, softcover, ISBN 0-02-369390-8, \$18.95.

Fundamentals of Computer

The New Avis Rapid Return.SM The Fastest Way To Return Your Car And Get A Record Of Your Expenses.

If you've been waiting at the counter to return your rental car and get a record of your expenses, Avis has great news. The wait is over.



You get a record of your expenses in seconds!

Avis has just introduced the new, computerized Avis Rapid Return,SM at selected airports and major downtown locations. It's the



fastest way to return your rental car and get a printed record of your expenses, to the penny. Automatically. Without waiting at the rental counter.

And Avis Rapid Return is as easy to use as a pocket calculator. Just enter your car number, your mileage and your gas gauge reading into the computer. With the push of a button, your car return is completed. And so is the record of your expenses.



Avis features GM cars. Chevrolet Caprice Classic.

Which means that you can catch your plane and get a record of your expenses, without ever waiting at the rental counter.

The new Avis Rapid Return. It's another Avis first that means better and faster service for you. And another way that Trying Harder Makes Avis Second to None.

TRYING HARDER MAKES AVIS SECOND TO NONE.SM



© 1983 Avis Rent A Car System, Inc. Avls*

We care about you, so whenever you drive, care about yourself. Please fasten your seat belt.

Avis Rapid Return service available for charge customers only who require no modification of rental agreement charges.

Books Received

Aided Analysis and Design (CAA/CAD) of Integrated Circuits, Processes and Devices, Andres Fortino. Reston, VA: Reston Publishing Co., 1983; 144 pages, 21.3 by 28 cm, softcover, ISBN 0-8359-2120-4, \$17.95.

A Guide to Programming—IBM Personal Computer, Bruce Presley. New York: Van Nostrand Reinhold, 1983; 304 pages, 21.5 by 27.8 cm, softcover, ISBN 0-442-26015-6, \$16.95.

How to Write and Publish Engineering Papers and Reports, Herbert B. Michaelson. Philadelphia, PA: ISI Press, 1982; 172 pages, 15 by 22.8 cm, hardcover, ISBN 0-89495-016-9, \$17.95.

The Illustrated Computer Dictionary, the editors of *Consumer Guide*. New York: Exeter Books and Skokie, IL: Publications International Ltd., 1983; 180 pages, 15.5 by 23 cm, softcover, ISBN 0-88176-099-4, \$4.98.

Information U.S.A., Matthew Lesko. New York: Penguin Books, 1983; 1008 pages, 17 by 23.5 cm, softcover, ISBN 0-14-046-564-2, \$19.95.

Mathematics for Data Processing, 2nd ed., Frank J. Clark. Reston, VA: Reston Publishing Co., 1974; 320 pages, 15.5 by 23.5 cm, hardcover, ISBN 0-87909-470-2, \$21.95.

Microcomputers for Libraries:

How Useful Are They?, Jane Beaumont and Donald Krueger, eds. Ottawa, Ontario, Canada: Canadian Library Association, 1983; 130 pages, 21.5 by 28 cm, spiral-bound, ISBN 0-88802-170-4, \$12.

Le Microprocesseur 68000 et Sa Programmation, Patrick Jaulent. Paris, France: Eyrolles (61, Boulevard Saint-Germain), 1983; 168 pages, 15.5 by 24.3 cm, softcover, ISBN 8549, price not available.

More Subroutine Sandwich, John P. Grillo and J. D. Robertson. New York: John Wiley & Sons, 1983; 270 pages, 17 by 25 cm, softcover, ISBN 0-471-86921-X, \$12.95.

Nine Steps to Effective EDP Loss Control, Tom S. Eason and Douglas A. Webb. Bedford, MA: Digital Press, 1983; 192 pages, 16 by 24.8 cm, hardcover, ISBN 0-932376-25-8, \$21.

PC Clearinghouse Software Directory, 7th ed. Fairfax, VA: PC Clearinghouse Publishers (11781 Lee Jackson Highway), 1983; 840 pages, 27.5 by 21.3 cm, softcover, ISBN 0-88674-000-2, \$29.95.

Problem Solving with Fortran 77, Larry Nyhoff and Stanford Leestma. New York: Macmillan Publishing Co., 1983; 368 pages, 17 by 25.5 cm, softcover, ISBN 0-02-388720-6, \$18.95.

Programmer's Guide to

CP/M, Sol Libes, ed. Morris Plains, NJ: Creative Computing Press (39 East Hanover Ave.), 1982; 204 pages, 20.5 by 27.5 cm, softcover, ISBN 0-916688-37-2, \$12.95.

Radio Antennas, Stephen Gibson. Reston, VA: Reston Publishing Co., 1983; 176 pages, 15.3 by 22.8 cm, softcover, ISBN 0-8359-6358-6, \$13.95.

6502 Assembly Language Programming, Judi N. Fernandez, Donna N. Tabler, and Ruth Ashley. New York: John Wiley & Sons, 1983; 288 pages, 17 by 25 cm, softcover, ISBN 0-471-86120-0, \$12.95.

Subroutine Sandwich, John P. Grillo and J. D. Robertson. New York: John Wiley & Sons, 1983; 274 pages, 17 by 25 cm, softcover, ISBN 0-471-86920-1, \$12.95.

Successful Business Computing, M. Tampoe. Woburn, MA: Butterworths, 1982; 130 pages, 14 by 22 cm, hardcover, ISBN 0-408-01217-X, \$19.95.

SuperCalc: The Book, Donald H. Beil. Reston, VA: Reston Publishing Co., 1983; 304 pages, 18 by 24 cm, hardcover, ISBN 0-8359-7306-9, \$21.95.

TRSDOS 2.3 Decoded & Other Mysteries, James Lee Farvour. Upland, CA: IJG Inc. (1953 West 11 St.), 1982; 304 pages, 20.8 by 17.5 cm, softcover, ISBN 0-936200-07-3, \$29.95.

TRS-80 Extended Color BASIC, Richard Haskell. Englewood Cliffs, NJ: Prentice-Hall, 1983; 176 pages, 21.5 by 27.8 cm, softcover, ISBN 0-13-931246-3, \$12.95.

UCSD Pascal: A Considerate Approach, David Price. Englewood Cliffs, NJ: Prentice-Hall, 1983; 208 pages, 17.3 by 23 cm, softcover, ISBN 0-13-935460-3, \$12.95.

Unix Programmer's Manual, 7th ed., vol. 2, Bell Telephone Laboratories. New York: Holt, Rinehart and Winston, 1983; 624 pages, 21 by 27.8 cm, softcover, ISBN 0-03-061743-X, \$34.95.

Up Front Financing: The Entrepreneur's Guide, A. David Silver. New York: John Wiley & Sons, 1982; 264 pages, 16 by 23.8 cm, hardcover, ISBN 0-471-86386-6, \$15.95. ■

This is a list of books received at BYTE Publications during this past month. Although the list is not meant to be exhaustive, its purpose is to acquaint BYTE readers with recently published titles in computer science and related fields. We regret that we cannot review or comment on all the books we receive; instead, this list is meant to be a monthly acknowledgment of these books and the publishers who sent them.

BASIS 108

U.S. #1 DEALER FOR AUTHORIZED SALES & SERVICE

"COLOSSUS™ BASIS"

128K RAM; BASRAM 256K CARD;
CP/M 3.0; APPLE DOS 3.3
DR#1; RANA ELITE THREE 680K
DR#2; SEAGATE 10MG HARD DISK
METACARD - THE 16BIT BOARD FOR MS-DOS;
CP/M-86, UCSD PASCAL VER. IV
COMPATIBILITY

"BASIC BASIS"

128K RAM ON BOARD
2 SIEMENS 40 TRACK DRIVES
BASIS SYSTEM AUTO DIAGNOSTICS
W/ CONTROLLER; CP/M 3.0; APPLE DOS 3.3

* CUSTOM BASIS CONFIGURATION AVAILABLE *
CALL FOR CONSULTATION & WRITTEN PRICE QUOTE
48 HR. CONTINENTAL U.S. WARRANTY SERVICE
REPLACEMENT. FREE 24 HR. SIGN ON TO OUR
BASIS BULLETIN BOARD.

STATE OF THE ART MICROS

 
COMMUNI INC. CAL TM

1400 GRANT AVE., NOVATO, CALIFORNIA 94947
ORDER TOLL FREE 1-800-421-6594
IN CALIFORNIA CALL COLLECT 415-892-7139
CLIENT TECH SUPPORT 415-897-1414

BUY COMPUTERS FROM PEOPLE WHO KNOW HOW TO USE THEM.
SERVICES AVAILABLE: SOFTWARE APPLICATIONS • HARDWARE PERIPHERALS
COMPUTER SECURITY • TELECOMMUNICATIONS • BUSINESS • SCHOOLS
CORPORATIONS • CONSULTATION SERVICES • 24-HR. AIR EXPRESS AVAILABLE
Ask about our clients. All equipment tested prior to shipment.
If you don't see it, please ask us.

COLUMBIA

CP/M & IBM PC COMPATIBILITY
128K RAM, 8 SLOTS
DUAL 320K DRIVES

EPSON PRINTERS • COMPUTERS
HAYES MODEMS • THUNDERCLOCK
NEC PRINTERS • MONITORS
SOFTWARE BY MICROSOFT,
MICRO PRO, SORCIM, PERFECT & MORE



Minimum order \$100. Cashiers checks and money orders accepted. Add 3% for Visa or MC. Add 3% for shipping/insurance/handling. UPS No COD. Prices subject to change. Call to verify. Order hours 10-7PDT. Mon-Fri. Personal checks allow 20 days to clear. All products with full manufacturer's warranty, factory sealed. Calif. residents add 6% sales tax. Bank wires and P.O.s accepted. Retail prices may vary.

ALL BRAND NAMES ARE REGISTERED TRADEMARKS.

The Micromint Collection

Micromint. Supporting the varied projects that appear in Steve Ciarcia's monthly article in *BYTE* magazine, "Ciarcia's Circuit Cellar." Offering a wide range of computers and peripherals supporting the needs of the hobbyist as well as worldwide corporate clients.

MPX-16 MICROCOMPUTER IBM PC COMPATIBLE



The MPX-16 is Steve Ciarcia's most ambitious project to date. The computer runs all application software written for the IBM PC and is IBM PC bus compatible. Can be used with video monitor & IBM keyboard with optional adapter.

Buy the MPX-16 in the form that best meets your budget. As a bare board, as a wave-soldered board that contains all components less the IC's, as an assembled and tested circuit board or as a complete system.

As featured on the cover of "BYTE" magazine. Also featured in "Ciarcia's Circuit Cellar" November, December 1982 & January 1983.

- Runs all application programs written for the IBM PC (simply boot up the system and slip in a disk formatted for the IBM PC).
 - IBM PC bus compatible + 9 expansion slots.
 - Intel 8088 16-bit microprocessor.
 - Optional Intel 8087 math coprocessor.
 - 256K bytes on-board memory.
 - Up to one megabyte of system memory.
 - Up to 64K bytes of system ROM/EPROM.
 - Two RS-232C serial I/O ports.
 - Three parallel I/O ports.
 - Disk controller for 5 1/4" or 8" drives.
 - Sixteen levels of vectored interrupts.
- MPX-16 Microcomputer circuit board assembled w/64K RAM, CP-M-86 or MS-DOS \$1,895.
- MPX-16 as above with 256K RAM 2,135.
- MPX-16 Semi-Kit (wave soldered circuit board w/all components) less IC's 595.
- Complete kit of IC's w/256K RAM 595.
- MPX-16 Unpopulated (bare) pc board 300.
- CP-M-86 Operating System 200.
- MS-DOS optionally available
- MPX-16 Switching Power Supply including cable harness for 2 disk drives 300.
- MPX-16 Technical Reference Manual 50.
- MPX-16 Metal Enclosure with cutouts for two 5 1/4" full height drives 300.
- Tandon TM 100-2 double density drive 300.
- Televideo Model 910 Serial Terminal 675.
- IBM PC Keyboard Interface Adapter 100.
- Serial terminal cable 35.
- Parallel printer cable 35.
- Shipping and handling additional on MPX-16 orders.

Z8 BASIC SYSTEM CONTROLLER NEW!!!

Replaces Z8 Basic Computer/Controller



As featured in Ciarcia's Circuit Cellar, BYTE magazine, July & August 1981.

- Uses Zilog Z8671 single chip microcomputer.
 - On board tiny BASIC Interpreter.
 - 2 parallel ports plus serial I/O port.
 - Just connect a CRT terminal and write control programs in BASIC.
 - 2K bytes of RAM, up to 4K bytes of ROM.
 - Baud rates 110-9600 BPS.
 - Data and address buses available for 124K memory and I/O expansion.
 - Consumes only 1.5 watts at +5, +12 & -12.
 - Cross Assemblers for various computers.
- BCC11 Assembled & Tested \$149.
- New Low Price

IBM PC is a trademark of International Business Machines. Inc.
CP M86 is a trademark of Digital Research Inc.
MS-DOS is a trademark of Microsoft Inc.
Z8 is a trademark of Zilog Inc.

Z8 MEMORY, I/O EXPANSION, CASSETTE INTERFACE

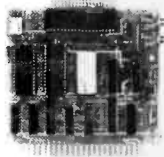

- Add up to 8K of memory plus 3 parallel ports.
 - Cassette Interface—300 baud K.C. Standard.
- BCC03 w/4K Assembled & Tested \$140.

Z8 ANALOG TO DIGITAL CONVERTER NEW!!!

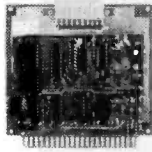

- Uses Analog Devices 7561 8 channel 8 bit IC.
 - Adds Process Control capability to the Z8.
 - 1000 samples per second.
- BCC13 Assembled & Tested \$140.

Z8 EPROM PROGRAMMER



- Transfer BASIC or Assembly Language application programs from RAM to 2716 or 2732 EPROM.
 - Requires Z8 Expansion Board for operation.
- BCC07 Assembled & Tested \$145.

Z8 SERIAL EXPANSION BOARD

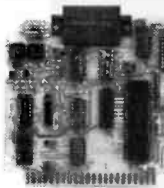

- Adds additional RS 232C and opto-isolated 20 ma current loop serial port to the Z8.
 - Runs at 75 to 19,200 baud in all protocols.
- BCC08 Assembled & Tested \$160.

Z8 16K MEMORY EXPANSION BOARD NEW!!!

- Add 16K of additional memory, RAM or EPROM, to your Z8 System Controller in any multiple.
 - Uses 2016, 6116, 2716 or 2732 memory types.
- BCC14 w/8K Assembled & Tested \$120.

Z8 FIVE SLOT MOTHER BOARD



MB02 Assembled & Tested \$69.

Z8 CROSS ASSEMBLERS

- From Allen Ashley
- TRS-80 Model I or III \$75.
- CP/M 2.2 8" or Northstar 5 1/4" 150.
- From Micro Resources
- CP/M 2.2 8" or APPLE 5 1/4" 75.

SPEECH SYNTHESIZERS

MICROVOX TEXT-TO-SPEECH SYNTHESIZER

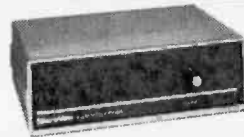

As featured in Ciarcia's Circuit Cellar BYTE Magazine September, October 1982.

Microvox is a second generation professional voice quality text-to-speech synthesizer that is easily interfaced to any computer, modem, RS-232C serial or parallel output device and provides speech of unbelievable clarity.

- Unlimited vocabulary.
 - 64 programmable inflection levels.
 - 6K text-to-speech algorithm.
 - Full ASCII character set recognition and echo.
 - RS232C and parallel output.
 - 1000 character buffer, 3000 optional.
 - Adjustable baud rates (75-9600).
 - Spelling output mode.
 - 7 octave music and sound effects.
 - On board audio amplifier & power supply.
 - X-On/X-Off handshaking.
- MV01 Assembled with 1K buffer \$299.
- MV02 Complete Kit with 1K buffer 219.
- Add \$15.00 for 3K buffer option.

SWEET-TALKER VOICE SYNTHESIZER

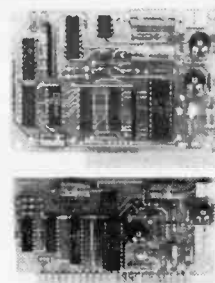

As featured in Ciarcia's Circuit Cellar BYTE Magazine, September 1981

The Sweet-Talker Voice Synthesizer allows you to add speech of unlimited vocabulary to your Apple II or any computer with a parallel printer port at very low cost.

- Utilizes Voltax SC-01A speech synthesizer.
 - Unlimited vocabulary.
 - Text-to-Speech Algorithm on disk for Apple II.
 - Contains 64 phonemes accessed by 6-bit code.
 - Four levels of programmable inflection.
 - On board audio amplifier & volume control.
- ST02 Apple II plug-in, Assembled & Tested with Text-to-Speech Algorithm on 3.3 disk .. 141.
- NEW LOW PRICE!!!
- ST01 Parallel Port Version, Assembled 99.
- New Low Price

VOTRAX SC-01A PHONETIC SPEECH SYNTHESIZER

The SC-01A Speech Synthesizer is a completely self-contained solid state device that phonetically synthesizes continuous speech of unlimited vocabulary. Used in Microvox and Sweet-Talker.

- SC01A Quantity 1-99 \$44.00.
- 100 + 32.00.
- 1000 + 24.00.

E-Z COLOR GRAPHICS INTERFACE

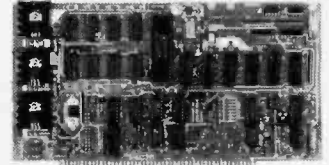

As featured in Ciarcia's Circuit Cellar BYTE Magazine, August 1982

Add color graphics, animation & 3-D effects to your S-100, TRS-80 Model I and III & Apple II at low cost. The Super Editor software package includes a pattern editor, sprite editor, slide show, and demo scenes all in BASIC. Can be used with Color Monitor or TV set and rf modulator.

- Resolution—256 X 192 Pixels.
- 16 colors including Black & Transparent.
- 16K Bytes on board I/O mapped video memory.
- Advanced TI TMS9918A Color Video Processor.
- 32 SPRITES facilitates 3-D effect.
- Composite Video output.
- Krell & Terrapin have LOGO software packages to support the E-Z Color Boards.

Apple II E-Z Color plug-in board with Super Editor on 3.3 disk.

- EZ01 Assembled & Tested \$150.
- EZ02 Complete Kit 125.
- NEW!! S-100 E-Z Color Graphics board with sound generator, Atari type joy stick interface, plus MBasic CP/M Super Editor Software on 8" disk.
- EZ04 Assembled & Tested \$289.
- TRS-80 Model I or Model III E-Z Color w/ Super Editor software, power supply and enclosure. Assembled & Tested \$249.
- Complete Kit 219.

300 BAUD ANSWER/ ORIGINATE MODEM KIT NEW!!!

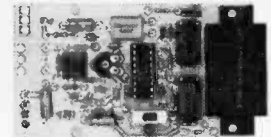

As featured in Ciarcia's Circuit Cellar BYTE Magazine, March 1983

The newest item to Micromint's growing list of products is this 300 Baud Modem. It is crystal controlled, uses the TI TMS 99532 IC, contains just 25 parts and can be used with an acoustic coupler or in a direct connect mode.

- MD04 Complete Kit \$60.
- MD05 Transformer for Direct Connect Mode 9.
- AC01 Acoustic Coupler Kit 18.

TRIPLE VOLTAGE POWER SUPPLIES

- +5v @ 300 ma. +/- 12v @ 25 ma.
- UPS01 Assembled & Tested \$35.
- UPS02 Complete Kit 27.
- +5v @ 1 Amp. + 12v @ .5 Amp. - 12v @ 50 ma.
- UPS03 Assembled & Tested 60.
- UPS04 Complete Kit 50.

MICROMINT INC. 561 Willow Avenue, Cedarhurst, NY 11516
To Order: Call Toll Free 1-800-645-3479
For Information Call: 1-516-374-6793
Call: Monday-Friday, 9-5 PM

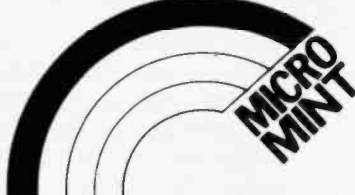

Event Queue

October 1983

October

Courses in Continuing Engineering Education, Orlando, FL, San Diego, CA, and Washington, DC. Two of the available courses are "An Applications-oriented Approach to Artificial Intelligence" and "Computer Graphics Systems: Hardware, Software, and Applications." For information on dates, locations, and fees, contact Douglas Green, George Washington University, Continuing Engineering Education, Washington, DC 20052, (800) 424-9773; in the District of Columbia, (202) 676-8512.

October-November

Computer Showcase Expos, various sites throughout the U.S. This popular show will bring together hardware and software manufacturers, dealers, and consumers of small computer systems. For further details, contact the Interface Group, 160 Speen St., POB 927, Framingham, MA 01701, (800) 225-4620; in Massachusetts, (617) 879-4502.

October-November

Courses from the Continuing Education Institute, various sites throughout the U.S. Among the courses offered are "Database Machines," "Local Networks Technology and Applications," and "Man-Machine Interface." For more information, contact the Continuing Education Institute, Oliver's Carriage House, 5410 Leaf Treader Way, Columbia, MD 21044, (301) 596-0111; in California, (213) 824-9545.

October-November

Courses from Integrated Computer Systems, various sites throughout the U.S. Course titles include "Digital Image Processing," "De-

signing Real-Time Hardware for Digital Signal Processing," "Designing Digital Control Systems," and "Digital Signal Processing." The fee for these courses is \$895. For information, contact Ruth Dordick, Integrated Computer Systems, 3304 Pico Blvd., POB 5339, Santa Monica, CA 90405, (213) 450-2060.

October-December

Intensive Seminars for Professionals, various sites throughout the U.S. *Electronics* magazine, a McGraw-Hill publication, offers seminars in management and such technical areas as speech recognition and synthesis, controlling electromagnetic interference, fundamentals of computer graphics, and microprocessor interfacing. In-house presentations can be arranged. For a catalog outlining seminars, locations, and fees, contact Irene Parker, McGraw-Hill Seminar Center, Suite 603, 331 Madison Ave., New York, NY 10017, (212) 687-0243.

October-December

James Martin Seminars and Seminars of Excellence, various sites throughout the U.S. and Canada. For a brochure describing these data-processing and computer-related seminars, contact Technology Transfer Institute, 741 10th St., Santa Monica, CA 90402, (213) 394-8305.

October-December

Seminars for Professional Development, various sites throughout the U.S. Datapro Research Corporation offers more than 35 professional development seminars in such areas as personal computers, data communications, systems and software, and office automation. Complete outlines and schedules are available from Datapro Research

Corp., 1805 Underwood Blvd., Delran, NJ 08075, (800) 257-9406; in New Jersey, (609) 764-0100.

October-December

Software Workshops in MMSFORTH, Boston metropolitan area. These workshops are public versions of the professional training Miller Microcomputer Services (MMS) offers to client companies in support of the MMSFORTH product line. A variety of topics and skill levels are covered. Full details are available from Miller Microcomputer Services, 61 Lake Shore Rd., Natick, MA 01760, (617) 653-6136.

October-January 1984

Courses from Q. E. D. Information Sciences, various sites throughout the U.S. Scheduled courses include "Systems Analysis Workshop," "Database Design," and "Project Management and Control." Address inquiries to Q. E. D. Information Sciences Inc., Q. E. D. Plaza, POB 181, Wellesley, MA 02181, (800) 343-4848; in Massachusetts, (617) 237-5656.

October-January 1984

Technology Opportunity Conference, various sites throughout the U.S. This conference series focuses on the convergence of optical-storage, videodisc, and computer technologies. For full details, contact Technology Opportunity Conference, POB 14817, San Francisco, CA 94114, (415) 626-1133.

October-August 1984

Conferences and Expositions from the Society of Manufacturing Engineers, various sites throughout the U.S. and around the world. More than 25 conferences and expositions are scheduled. For a calendar, contact the Public Relations Department, Soci-

ety of Manufacturing Engineers, One SME Dr., POB 930, Dearborn, MI 48121, (313) 271-0777.

October 10-12

CEPA 1983 Fall Conference, the Saint Paul, St. Paul, MN. Topics to be addressed at this conference sponsored by the Society for Computer Applications in Engineering, Planning, and Architecture (CEPA) include selection of software and hardware, experiences with applications, and networking of systems. An exhibit area will show various hardware and software products being used by design professionals. Contact Patricia Johnson, CEPA Inc., 358 Hungerford Dr., Rockville, MD 20850, (301) 762-6070.

October 10-12

Online '83, Palmer House, Chicago, IL. The fifth annual Online conference and exposition features introductory and advanced technical sessions, panel discussions, workshops, seminars, and addresses. The role of microcomputers and software for database searching, storage, creation, and communications will be emphasized. Registration information is available from Online Inc., 11 Tannery Lane, Weston, CT 06883, (203) 227-8466.

October 10-13

Information Management Exposition and Conference: Info 83, New York City Coliseum. Hardware and software exhibits and conference sessions will revolve around the theme "Tying the Information System to the Business Plan." A number of the conference sessions will deal with decision support systems. For details, contact the Marketing Manager, Info 83, 708 Third Ave., New York, NY 10017, (212) 661-8410.

Event Queue

October 10-14

Defense Computers-Graphics-DCG '83, Convention Center, Washington, DC. Sessions and tutorials will complement this conference and exhibition about computers and graphics for the defense community. For more information, contact DCG '83, Suite 333, 2033 M St. NW, Washington, DC 20036, (202) 775-9556.

October 11

Computer-assisted Manual Writing, Seattle, WA. This one-day seminar is designed to teach attendees how to produce good software manuals. The sponsor will demonstrate a software package for automated documentation development called Manual Maker. The fee is \$195. For further information, contact Promptdoc, 833 West Colorado Ave., Colorado Springs, CO 80905, (303) 471-9875.

October 11-12

Computer-aided Design Conference—CADCON East '83, Boston, MA. This conference consists of technical programs and exhibitions organized exclusively for computer-aided-design engineering. Details are available from Morgan-Grampian Expositions Group, 2 Park Ave., New York, NY 10016, (212) 340-9780.

October 11-13

Southwest Semiconductor & Electronics Exposition—SSE '83, Civic Plaza Convention Center, Phoenix, AZ. Approximately 200 suppliers of equipment, materials, and services used in the electronics industry will attend this show. A technical conference will be held. Contact Leigh Crystall, Cartledge & Associates Inc., Suite 205, 4030 Moorpark Ave., San Jose, CA 95117, (408) 554-6644.

October 11-14

Understanding Microprocessor-based Equipment and Troubleshooting, Rodeway Inn at Disneyland, Orange, CA. This course is designed to provide technicians and engineers with a background in microprocessor fundamentals and troubleshooting techniques. Equipment familiarization and hands-on experimentation are emphasized. The registration fee is \$595; multiple discounts are offered. Contact Micro Systems Institute, Garnett, KS 66032, (913) 898-6152.

October 12-21

The Sixth International Trade Exhibition on Office Organizational Systems, Office Furniture, and Office Aids—Systemotechnika '83, Vassilievsky Ostrov Exhibition Centre, Leningrad, Union of the Soviet Socialist Republics. On display will be communications systems, microfilming

equipment and systems, data-processing equipment, and computers. For details, contact Düsseldorf Messegesellschaft mbH-NOWEA—Central Division—Foreign Fairs, Düsseldorf Exhibition Centre, 4000 Düsseldorf 30, Federal Republic of Germany; tel: (02 11) 45 60-1.

October 13

Computer-assisted Manual Writing, Los Angeles, CA. For details, see October 11.

October 13-14

Computers in Construction, Chicago, IL. This seminar is designed to assist construction management firms and contractors in acquiring computer systems. The fee is \$425. Contact CIP Information Services Inc., 1105-F Spring St., Silver Spring, MD 20910, (301) 589-7933.

October 13-15

Edutech/East '83, Civic Cen-

CompuPro

8 and/or 16 Bits.

At CompuPro, we know it isn't enough to make the best computer system around — expert planning, custom configuration, tailored software and swift service are just as vital to our customers. That's why we carefully select and train each of our **Full Service CompuPro System Centers** to provide a complete solutions package for your high-performance computing needs. So for your business, scientific and industrial applications, turn to the professionals listed below. Think of them as your computer consultants—not just retailers.

ARIZONA

Scottsdale
S-100
(800) 528-3138

CALIFORNIA

Bakersfield
Creative Computing Services
(805) 325-9877

Berkeley

American Computers & Engineers
(415) 849-0177

Track Computer Center
(415) 845-6366

Burlingame

Mentzer Computer Systems
(415) 340-9363

Canyon Country

Creative Computing Services
(805) 251-9877

Carmichael

Logic Systems
(916) 971-3133

Chatsworth

Priority One Electronics
(213) 709-5464

Hayward

Byte Shop of Hayward
(415) 886-4732

Irvine

Priority One Electronics
(714) 660-1411

Los Angeles

American Computers & Engineers
(213) 477-6751

Gifford Computer Systems
(213) 477-3921

Mountain View

ACC
(415) 969-4969

Oakland

Track Computer Center
(415) 444-8725

Pacific Palisades

System Interface Consultants
(213) 454-2100

Pasadena

Omni Unlimited
(213) 795-6664

Petaluma

Advanced Information Mgmt.
(707) 763-7283

ter, Philadelphia, PA. This conference and exposition is designed for educators at all levels. Presentations will address such topics as computer-aided instruction, administrative uses of computers, classroom management, programming, research applications, authoring languages, and literacy. The format includes workshops, seminars, demonstrations, hands-on sessions, discussions, and micro courses. Hardware, software, and publishing companies will exhibit their wares. Contact Carol Houts, Judco Computer Expos Inc., Suite 201, 2629 North Scottsdale Rd., Scottsdale, AZ 85257, (800) 528-2355; in Arizona, (602) 990-1715.

October 14-15

Computers and Reading/Learning Difficulties, Dallas, TX. Workshops, hands-on exhibits, and speakers will ex-

plore such topics as using computers in learning disability classrooms and evaluating software. This program is designed for all education levels. For information, contact Frost Conference Management, Department I, 1070 Crows Nest Way, Richmond, CA 94803, (415) 222-1249.

October 14-15

The Fifth Annual FORTH Convention, Hyatt Hotel, Palo Alto, CA. Hands-on tutorials, exhibits, lectures, and discussions highlight this event. The theme is "FORTH-based Systems—A Look Into the Future." Registration is \$5. Full details are available from the FORTH Interest Group (FIG), POB 1105, San Carlos, CA 94070, (415) 962-8653 (FIG hot line).

October 14-16

Futureteach Conference, Cathedral Hill Hotel, San Francisco, CA. General ses-

sions, hands-on exhibits, and specialized workshops will seek to impart an understanding of how technology has and will continue to alter the way in which classroom instructors teach. For information, contact Westly Enterprises, 3697 South Court, Palo Alto, CA 94306, (415) 494-7115.

October 14-16

The UCSD Pascal System Users Society (USUS) Fall Meeting, Crystal City Hyatt Hotel, Arlington, VA. This meeting will feature presentations, hardware and software demonstrations, language tutorials, and special-interest group meetings. Contact Thomas Woteki, Information Systems Inc., Suite 202, 3865 Wilson Blvd., Arlington, VA 22203, (703) 522-8898.

October 15-16

Amacom, City Park campus, Delgado Community College,

New Orleans, LA. This hamfest/computerfest offers demonstrations, sessions, commercial exhibits, and a flea market. Contact Amacom '83, POB 73665, Metairie, LA 70033, or call Bill Bushnell, WASMJM, at (504) 887-5022.

October 15-16

The Seventh New Jersey Microcomputer Show and Flea Market, Meadowlands Hilton Hotel, Secaucus, NJ. Featured will be home, hobby, and small business computers, software, supplies, books, and accessories. Admission is \$5 for adults; \$2 for children. Contact Kengore Corp., POB 13, Franklin Park, NJ 08823, (201) 297-2526.

October 16-18

The Fifth Annual Hong Kong Consumer Electronics Show, New World Hotel and Regent Hotel, Hong Kong. For details, contact IBS Trade Fair

Spoken Here...

Pleasanton

Best Computer Stores
(415) 463-2233

San Francisco

Gifford Computer Systems
(415) 391-4570

San Leandro

Gifford Computer Systems
(415) 895-0798

San Rafael

Computer House
(415) 453-0865

Santa Barbara

Data Bank
(805) 962-8489

Santa Maria

Data Bank
(805) 922-1333

Santa Rosa

Matrix Computers
(707) 542-0571

Sunnyvale

Pragmatic Designs, Inc.
(408) 736-8670

FLORIDA

Brandon

Micro Computer Technology
(813) 685-7659

Satellite Beach

Binary Magic, Inc.
(305) 777-7080

HAWAII

Kahului Maui

Capacity Plus Computers
(808) 877-3496

ILLINOIS

Athens

Computers Plus
(217) 636-8491

La Grange Park

Small Business Systems, Inc.
(312) 579-3311

Skokie

Lillipute Computer Mart, Inc.
(312) 674-1383

INDIANA

Terre Haute

General Software, Inc.
(812) 234-9421

MARYLAND

Bethesda

JR Systems
(301) 657-3598

MASSACHUSETTS

Boston

New England Electronic Exch.
(617) 491-3000

(Please turn the page)

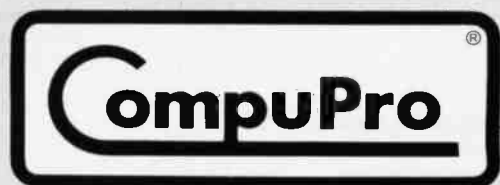

CompuPro, a **GOBBOUT** Company
3506 Breakwater Court, Hayward, CA 94545

Event Queue

Ltd., 17th Floor, Tung Sun Commercial Centre, 200 Lockhart Rd., Hong Kong; tel: 5-732388-9; Telex: 63037 HKIBS HX.

October 16-18

Texas Association for Educational Data Systems 1983 Convention, Austin Hilton Hotel, Austin, TX. The theme for this year's convention is "Computer Literacy." The keynote speaker will be Captain Grace Hopper of the U.S. Navy. Information may be obtained from Tom Hopper, Northside ISD, 5900 Evers Rd., San Antonio, TX 78238, (512) 618-8330, ext. 212.

October 17-19

The Eighth Conference on Local Computer Networks, Minneapolis, MN. The theme for this conference is "Practical Applications and Issues in Local Computer Networks." Papers and tutorials

will address such issues as users' versus manufacturers' needs, public versus private networks, software, and VLSI (very-large-scale integration). Contact the IEEE Computer Society, POB 639, Silver Spring, MD 20901.

October 17-21

Systems 83, Munich, West Germany. Computers, peripherals, and software will be displayed by more than 600 firms from 35 nations. For additional information, contact Kallman Associates, 5 Maple Court, Ridgewood, NJ 07450, (201) 652-7070.

October 18-20

The Fourteenth Annual International Test Conference, Franklin Plaza Hotel, Philadelphia, PA. For information, contact the Conference Registrar, POB 371, Cedar Knolls, NJ 07927, (201) 267-7120.

October 18-21

HP 1000 IUG 1983 International Conference, Hyatt Regency Hotel, Fort Worth, TX. This conference features technical sessions and tutorials for users of the Hewlett-Packard 1000 family of real-time engineering and scientific computers. Contact the Conference Manager, HP 1000 IUG, 289 South San Antonio Rd., Los Altos, CA 94022, (415) 941-1943.

October 18-21

The Third Symposium on Microcomputer and Microprocessor Applications- μ P '83, Hotel Duna Intercontinental and the Hungarian Academy of Sciences, Budapest, Hungary. The conference language will be English. Full details are available from Mrs. I. Bába, Scientific Society for Telecommunication, POB 451, H-1372 Budapest, Hungary; tel: (36) 1 113-027; Telex: MTESZ 22-5792.

October 18-21

Understanding Microprocessor-based Equipment and Troubleshooting, Belmont-Marine World Holiday Inn, Belmont, CA. For details, see October 11-14.

October 19-20

Calgary Computer & Office Automation Show and Conference, Roundup Centre, Calgary, Alberta, Canada. For details, contact Industrial Trade Shows of Canada, 20 Butterick Rd., Toronto, Ontario M8W 3Z8, Canada, (416) 252-7791.

October 19-21

The Fourth Canadian Symposium on Instructional Technology, Westin Hotel, Winnipeg, Manitoba, Canada. This symposium, designed for professionals in education and training and those interested in computer-aided learning, will explore the theme "Computer Tech-

...And Here.

Chestnut Hill

Key Micro Systems
(617) 738-7306

NEW YORK

Amherst
Gifford Computer Systems
(716) 833-4758

Deer Park

Datapro Systems, Inc.
(516) 595-1311

Staten Island

John D. Owens Associates, Inc.
(212) 448-6283

NORTH CAROLINA

Greensboro
General Semantics, Inc.
(919) 288-1117

OREGON

Portland
Microwest Computer Products
(503) 238-6274

RHODE ISLAND

Coventry
Key Micro Systems
(401) 828-7270

TEXAS

Austin
CPA Systems Inc.
(512) 458-9281

Dallas

Dator Systems
(214) 521-0915

Houston

Gifford Computer Systems
(713) 877-1212

Seguin

CPA Systems Inc.
(512) 379-0660

WISCONSIN

Greenfield
Byte Shop of Milwaukee
(414) 281-7004

Madison

Beam International
(608) 255-2325

CANADA

Burnaby, B.C.
Dynacomp Business Computers Ltd.
(604) 299-3747

Coquitlam, B.C.

CSC System Center Ltd.
(604) 941-0622

THE PHILIPPINES

Quezon City
Corona International Inc.
78-34-71

UNITED KINGDOM

Swansea
Comcen Technology Ltd.
(0792) 796000

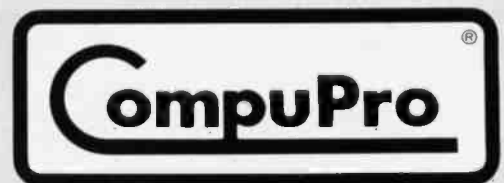

CompuPro, a **GODBOUT** Company
3506 Breakwater Court, Hayward, CA 94545

nologies for Productive Learning." Topics on the agenda include computer awareness and literacy in schools and society, systems technology, and computer-aided training and retraining for business, industry, and government. A products exhibition will be held. Contact Ken Charbonneau, Conference Services Office, National Research Council of Canada, Ottawa, Ontario K1A 0R6, Canada, (613) 993-9009; Telex: 053-3145.

October 19-21
IDATE—The Fifth International Conference, Montpellier, France. The theme for this conference, sponsored by the International Telecommunication Union, is "Picture Networks." Topics of interest include network functioning and areas of applications, economics and law relating to the visual media, network languages, and languages on the networks. The conference language is French. For further details, contact Francois Rabaté, Responsable Scientifique, Journées Internationales 1983, IDATE—Bureaux du Polygone, 34000 Montpellier, France; tel: (33-67) 65 48 48; Telex: IDATE 490 290.

October 19-21
The National Software Show, Trade Show Center, San Francisco, CA. Full details are available from Ragging Bear Productions Inc., Suite 175, 21 Tamal Vista Dr., Corte Madera, CA 94925, (800) 732-2300; in California, (415) 924-1194.

October 19-21
SIBEC—Info Expo, Palais des Congrès, Montréal, Québec, Canada. Exhibits related to the computer and office automation industries will be held. An international lineup of speakers has been invited. Contact Informatique Québec (Info Expo) Ltée, 1057 Avenue Laurier Ouest, Outre-

mont, Québec H2V 2L2, Canada, (514) 270-5481; in the Toronto area, call (416) 281-3459.

October 19-22
Management Executives Conference, The Breakers, Palm Beach, FL. The "Third Industrial Revolution" is the theme for this conference sponsored by the American Society of Mechanical Engineers (ASME). Management experts will speak on such topics as executive effectiveness and management for international competition. Complete conference details are available from Wendy Morris, ASME, 345 East 47th St., New York, NY 10017, (212) 705-7788.

October 19-22
Percompasia 83—The Second South East Asian Personal Computer Hardware & Software Show & Conference, World Trade Centre, Singapore, Republic of Singapore. This show is devoted to all aspects of personal computing. Further details are available from Overseas Exhibition Services Ltd., 11 Manchester Square, London W1M 5AB, England; tel: 01 486 1951; Telex: 24591.

October 23-26
The Seventh Annual Symposium on Computer Applications in Medical Care (SCAMC), Baltimore Convention Center, Baltimore, MD. Some of the topics to be covered include medical applications and solutions to problems of computers and technology in health care. For details, contact SCAMC, George Washington University Medical Center, Office of Continuing Medical Education, 2300 K St. NW, Washington, DC 20037, (202) 676-8928.

October 24-25
The Second Annual Pacific Northwest Computer Graphics Conference, Eugene Con-

BEST IN PRICE & QUALITY

Call Now TOLL FREE 800-368-3404

(In VA, Call Collect 703-237-8695)

AMPEX • INTERTEC • TEXAS INSTRUMENTS • GENERAL DATA COMM. • ANDERSON JACOBSON • C. ITOH • QUME • BEEHIVE • DATASOUTH • DIABLO • CENTRONICS • NEC • PRENTICE

MICROS

INTERTEC SUPERBRAIN II

64K DD* \$1874
 64K QD* \$2249
 64K SD* (96TPI) \$2689
 *(Includes M/Soft BASIC)
 DYNABYTE 8/16 BIT Call
 CALLAN 16/32 BIT Call

PRINTERS

NEC

7710 Ser. \$1899
 7715 \$1949
 7730 Par. \$1899
 7720 \$2449
 7725 \$2496
 Std. Tractor 77xx \$ 199
 3510 \$1364
 3515 \$1394
 3530 \$1390
 3550 (IBM) \$1709

DATASOUTH DS180 Call
 DATASOUTH DS220 Call

DIABLO

620-SPI \$ 889
 630-R-102/147 \$1949
 630ECS \$2389
 630-R155* \$1709
 *(for IBM PC, Apple II, TRS-80)
 630K104 (KSR) \$2265

QUME

Sprint 11/40-PLUS \$1355
 Interface \$ 76
 Sprint 11/55 Call
 Sprint 9/45 FP \$1794
 Sprint 9/55 FP \$2080
 Bi-Dir Forms Tractor \$ 199

CENTRONICS: 122 Par. \$ 689
 351 \$1673
 BarCode \$ 98

TERMINALS

AMPEX

D80 \$ 689

PHAZE (3270 Ex. Mem) \$1589

BEEHIVE (SMART DISPLAY)

DM5 Call
 DM5A Call
 DM83 (Burroughs) Call
 DM3270 (3270 Emulator) Call
 Protocol Converter Call

QUME

QVT-102 \$ 549
 QVT-108 Call

C. ITOH

CIT 101 \$1289
 CIT 161 (64 Colors) Call
 CIT 201 (Graphics for TEK 4010/4014) Call

CIT 414 (Graphics

640 x 480 Res.) Call

TEXAS INSTRUMENTS

745 Standard \$1172
 745 Std. (Reconditioned) Call
 765 Bbl M/my Call
 785/787 Call
 810 Basic \$1249
 810 Package \$1439
 820 Package RO \$1610
 820 KSR Package Call
 703 Std. \$ 459
 707 KSR \$ 549
 850 Tractor Feed \$ 549

MODEMS

Prentice Star 300 Bd. \$ 124
 U.S. Rob Password AD (212A) .. \$ 347
 US Rob TelPack \$ 69
 Stat Muxes Call
 Ventel 212 + 3E Call
 Prentice 24/9600 bd. Call

DISC DRIVES

QUME

Data Trak 5 \$ 289 or 2 for \$ 549
 Data Trak 8 \$ 519 or 2 for \$ 999

SOFTWARE

BISYNC-3780 \$ 569
 WordStar \$ 279
 DataStar \$ 218
 Mail Merge \$ 144
 SpellStar \$ 144
 Plan 80 \$ 249
 d Base II \$ 489
 CalcStar \$ 119
 SuperSort \$ 144
 SuperCalc \$ 144
 InfoStar \$ 279
 InfoStar (8") Special \$ 249
 CIS Cobol \$ 689
 Forms II \$ 159
 MACRO 80 \$ 183
 "C" Compiler \$ 239
 WordStar Professional (WS, SS, MM, S1) \$ 399
 ReportStar \$ 199
 StarIndex \$ 129
 PlanStar Call
 StarBurst Call
 InfoStar Plus Call

IBM PC

256K RAM Bd. \$ 256
 256K RAM Bd Full Parity. \$ 305
 BabyBlue \$ 600
 BabyTex \$ 600
 BabyTalk 3270 BISYNC \$ 895
 8" Disk Controller \$ 395

We also make EIA RS 232 or RS 449 cables to your order, can supply you with ribbons, printer stands, print wheels, thimbles for all printers listed. Plus many, many more items. Most items in stock. CALL NOW.

All items shipped freight collect either motor freight or UPS unless otherwise specified. All prices already include 3% cash discount. Purchase with credit card does not include discount. Virginia residents, add 4% Sales Tax. For fastest delivery send certified check, money order or bank-wire transfer. Sorry, no C.O.D. orders. All equipment is in factory cartons with manufacturers warranty (honored at our depot). Prices subject to change without notice.



TERMINALS TERRIFIC

Terminals Terrific, Inc., P.O. Box 216, Merrifield, VA 22116
 Phone: 800-368-3404 (In VA, Call Collect 703-237-8695)

Huntington's Disease... The Genetic Time Bomb!

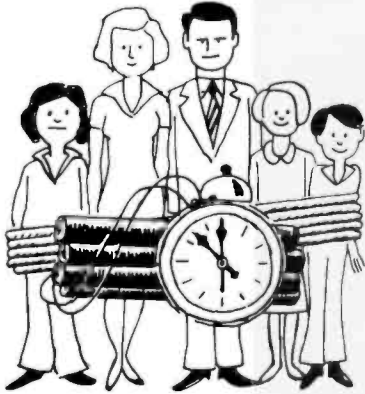

**NATIONAL
HUNTINGTON'S DISEASE ASSOCIATION**
Suite 501, 1441 Broadway, New York, N.Y. 10018
212-966-4320

79-11

THIS SPACE CONTRIBUTED BY THE PUBLISHER

Computer Protection

KLEEN LINE[®] CONDITIONER

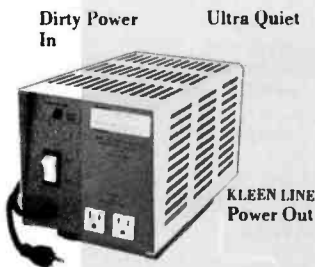

Prevents:

- Computer Damage
- Lightning Spike Damage
- Brownout Interruptions
- Disruptive Line Noise
- Program Errors

Regulator • Filter • Suppressor

KLR-250A	250 Watt Load	\$291.95
KLR-250A-1S0	250 Watt Load; Patented Filter Isolated Sockets	\$346.95
KLR-500A	500 Watt Load	\$390.95
KLR-500A-1S0	500 Watt Load; Patented Filter Isolated Sockets	\$445.95

Shipping: \$12.75 Land; \$45.50 Air

Ask Your Local Dealer

ESP[®] Electronic Specialists, Inc.
171 South Main Street, Box 389, Natick, Massachusetts 01780

Toll Free Order Desk 1-800-225-4876
MasterCard, VISA, American Express

Event Queue

ference Center, Eugene, OR. The theme for this multidisciplinary conference is "Applications on the Leading Edge." The goal is to present state-of-the-art computer graphics applications in architecture, medicine, landscaping, fine arts and graphic design, film and video, the sciences, and engineering. Exhibits of noncommercial graphics works and commercial product displays will complement the conference sessions. Information is available from the Second Annual Pacific Northwest Computer Graphics Conference, 111 Susan Campbell Hall, University of Oregon, Eugene, OR 97403, (503) 686-5555.

October 24-26

The Annual Conference of the Association for Computing Machinery-ACM '83, Sheraton Centre Hotel, New York, NY. Exhibits of computer hardware and software and paper sessions will focus on the conference theme, "Extending the Human Resource." The emphasis will be on theory and practices of personal computing. Highlighting the conference will be the Fourth International Computer Chess Championships. For details, contact Thomas A. D'Auria, Assistant Commissioner, City of New York, Computer Service Center, 11th Floor, 111 8th Ave., New York, NY 10011, (212) 620-5055.

October 25-27

Andean Informatics '83, Bogota, Colombia, South America. This is the first major international exhibition and conference to be held in the Andean region. For details, contact Informatics '83, Suite 219, 3421 M St. NW, Washington, DC 20007, (703) 920-9595.

October 25-28

Working Conference on Prototyping, Brussels, Belgium. This conference will focus on

the user-oriented development of information systems supported by prototyping. Research and technical papers will be presented. The sponsor is the Commission of the European Communities. For information, contact Reinhard Budde or Heinz Zuellighoven, GMD-IST Postfach 1240, Schloss Birlinghoven, D-5205, St. Augustin 1, West Germany; tel: 02241/14-2440; Telex: 8 89 469 gmd d.

October 26-28

Developing Long-Range Systems Strategies, Sheraton Hotel, Washington, DC. This is part of the George Washington University Executive Systems Forum series. Contact the Conference Manager, U.S. Professional Development Institute, 1805 Powder Mill Dr., Silver Spring, MD 20903, (301) 445-4400.

October 27-28

Computers in Construction, Washington, DC. For details, see October 13-14.

October 28-30

Applefest, Moscone Center, San Francisco, CA. More than 300 displays and booths of Apple computer equipment and accessories will be featured. Seminars, panel discussions, conferences, and workshops will be held. Details are available from Northeast Expositions Inc., 822 Boylston St., Chestnut Hill, MA 02167, (800) 343-2222; in Massachusetts, (617) 739-2000.

October 30-November 2

DPMA Baltimore '83, Convention Center and Hyatt Regency Hotel, Baltimore, MD. The theme for this conference, sponsored by the Data Processing Management Association (DPMA), is "Information on the Firing Line." Seminars, workshops, general sessions, and product displays will be featured. For details, contact Jim Osowski, DPMA International Head-

quarters, 505 Busse Highway, Park Ridge, IL 60068, (312) 825-8124.

October 30-November 4

Engineering Foundation Conference, Niagara-on-the-Lake, Ontario, Canada. The theme of this conference is "Emerging Computer Techniques in Stormwater and Flood Management." Topics to be covered include hardware and software applications in hydrometeorological data acquisition and data storage, retrieval and presentation. For details, contact Dr. William James, Civil Engineering Department, McMaster University, Hamilton, Ontario L8S 4L7, Canada, (416) 527-6944.

October 31-November 2

The Ninth International Conference on Very Large Databases, Palazzo dei Congressi, Florence, Italy. This conference seeks to identify and encourage the research, development, and applications of database technology. Subjects of interest include database control, modeling and managing unformatted data, and novel environments and applications of database technology. In the U.S., contact Mario Schkolnick, K55-281, IBM Research Labs, 5600 Cottle Rd., San Jose, CA 95193, (408) 256-1648. In Italy, contact Renzo Pinzani, Istituto di Matematica U. Dini, Viale Morgagni, 67/A, 50134 Florence, Italy.

October 31-November 3

International Conference on Computer Design-VLSI in Computers, Rye Town Hilton, Port Chester, NY. This conference will cover the VLSI (very-large-scale integration) aspects of the interaction between fabricators and systems designers in hardware, software, and reliability in computers. Contact the IEEE Computer Society, POB 639, Silver Spring, MD 20901.

October 31-November 4

Structured Systems Design/Structured Program Design, Kansas City, MO. For details, contact Ken Orr and Associates Inc., 1725 Gage Blvd., Topeka, KS 66604, (800) 255-2459; in Kansas, (913) 273-0653.

October 31-November 4

Welcome to the World of Personal Computing, Washington, DC. This is a comprehensive introduction on how to use microcomputer technology in business, industry, and government. The workshop agenda offers six modules ranging from user productivity to software reliability. For details, contact Keston Associates, 11317 Old Club Rd., Rockville, MD 20852, (301) 881-7666.

November 1983

November 1-2

The Annual Fall Conference of the Iowa Association for Educational Data Systems, Des Moines, IA. "Quality Software for the 80s: Development, Selection, and Usage" will be the focus of more than 40 sessions presented during this conference. Three preconference workshops will be held on October 31. For details, contact Phillip J. Berrie, Educational Services Division, Heartland AEA 11, 1932 Southwest Third St., Ankeny, IA 50021.

November 1-3

INTECH '83—The Integrated Office Technology Conference and Exposition, McCormick Place, Chicago, IL. This conference and exposition is designed to provide top management with high-level seminars, workshops, and equipment demonstrations that address the integration of information technologies and applications. Contact Mary

Main/Frames

Main/Frames

from
\$175

Wow!
70 Models!

- 70 Models of Enclosures
- Assembled and tested
- Quasi-Coax Motherboards
- Power Supply
- Card cage and guides
- Fan, line, cord, fuse, power & reset switches

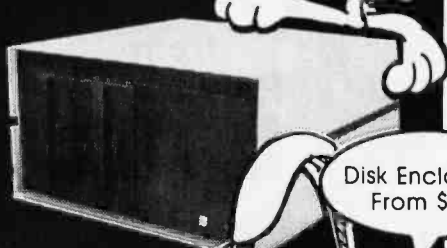

Disk Enclosures
From \$100

\$499

8" Floppy Main/Frame

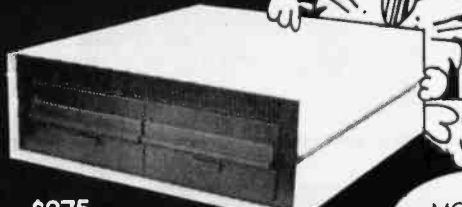

\$275

8" Disc Enclosure

MORE BANG
FOR THE BUCK

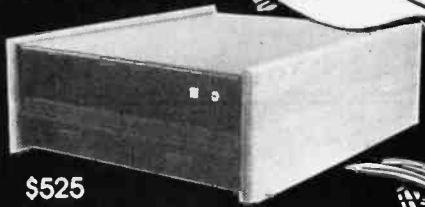

\$525

Phase/80 8" Floppy Main/Frame

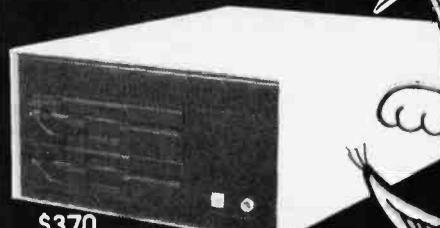

\$370

Slim Line 8" Floppy Main/Frame

32 Page
Free Fakt
Pakt Catalog

Write or call for our
brochure which includes our
application note:
"Making micros, better than
any ol' box computer"

INTEGRAND

8620 Roosevelt Ave. • Visalia, CA 93291
209/651-1203

We accept BankAmericard/Visa
and MasterCard

Radio Shack TRS-80™ Computers

At Guaranteed Savings

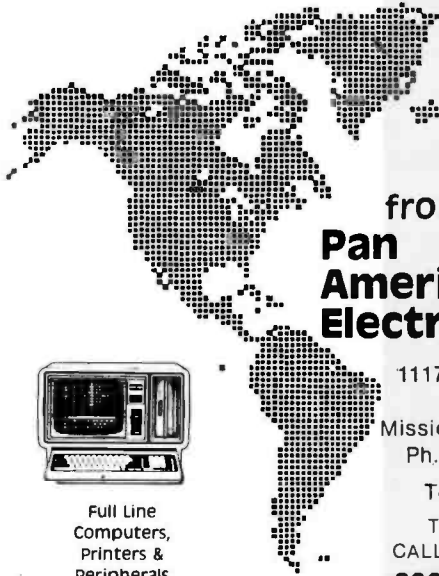

from
**Pan
American
Electronics**

1117 Conway Ave.
Dept. B
Mission, Texas 78572
Ph. 512/581-2766
Telex 767339
TO ORDER
CALL TOLL FREE
800-531-7466

Full Line
Computers,
Printers &
Peripherals

Event Queue

Beth Gouled, National Trade Productions Inc., 9418 Annapolis Rd., Lanham, MD 20706, (800) 638-8510; in Maryland, (301) 459-8383.

November 1-3

The 1983 Federal Office Automation Conference, Convention Center, Washington, DC. The theme for this conference and exposition is "Making It Work." The conference program will consist of seminars, workshops, technology briefings, and major addresses. The exposition segment will provide displays of the latest office automation equipment, systems, and services. Further details are available from the National Council for Education on Information Strategies, POB N, Wayland, MA 01778, (800) 343-6944; in Massachusetts, call (617) 358-5356, collect.

November 1-3

Western Design Engineering Show and Conference, Convention Center, Los Angeles, CA. Short courses on the agenda include "Principles of Robotics for Engineers," "Effective Project Management," and "Programming Personal Computers." Many of the 12 short courses will provide hands-on experience. An exhibition area will be featured. Contact the Marketing Director, Western Design Engineering Show, 708 Third Ave., New York, NY 10017, (212) 661-8410.

November 2-4

Digital Control Seminar, Washington, DC. For details, contact Hellman Associates Inc., Suite 300, 299 California Ave., Palo Alto, CA 94306, (415) 328-4091.

November 2-4

Edmonton Computer and Office Automation Show, Convention Centre, Edmonton, Alberta, Canada. For full details, contact Industrial Trade Shows of Canada, 20 Butterick

Rd., Toronto, Ontario M8W 3Z8, Canada, (416) 252-7791.

November 2-4

The First Annual Computer Vertical Market Conference, Meadowlands Hilton, East Rutherford, NJ. This conference, sponsored by Frost and Sullivan, will explore the impact of the new integrated software approaches and the importance of maintenance and support functions. Speakers will address vertical marketing issues from the perspective of the user, vendor, and industry analyst. Full particulars are available from Carol Sapchin, Frost and Sullivan Inc., 106 Fulton St., New York, NY 10038, (212) 233-1080.

November 3-4

Computers in Construction, Scottsdale, AZ. For details, see October 13-14.

November 3-6

Electronic Fun Expo, New York City Coliseum. This is a consumer electronics show. Full particulars are available from Electronic Fun Expo, 350 East 81st St., New York, NY 10028, (212) 734-4440.

November 3-6

The 1983 National Home Electronics Show, Arlington Park Exposition Hall, Arlington Heights, IL. This show covers electronic equipment and technology ranging from home computers to telecommunications security systems. It's produced by Lincoln Merchandising Co. Inc., 1417 Milwaukee Ave., Chicago, IL 60622, (312) 276-2819.

November 5-6

The Fourth Annual San Diego Computer Fair, Scottish Rite Center, San Diego, CA. This fair features short technical sessions, programming and computer games contests, commercial displays, and user group displays. For additional information, contact the San Diego Computer Society, POB

MODEMS/CRTS/PRINTERS/SWITCHES/ SWITCHES/MICRO COMPUTERS/CABLES		LIST	YOUR COST
MODEMS	UDS 212LP, 1200bps Full Duplex (212A)	445	CALL
	USR Password, 300/1200bps FD (212) Auto Dial	449	CALL
	USR Courier 300/1200bps FD (212A) Auto Dial	519	CALL
	Rixon R212L, 300/1200bps FD (212A) Auto Dial	499	CALL
	Rixon PC 212A (IBM PC Modem Corrl)	499	CALL
	Hayes Smart 1200	676	CALL
	PENRIL 300/1200 AD Auto Dial	796	CALL
NEC 300/1200 Auto Dial, Auto Log On	796	CALL	
CRT	Visual 50/55 CRT	695	CALL
	DEC VT100-AA	1895	CALL
	Adds Viewpoint A-1	650	CALL
	Taxan RGB Vision Monitor	399	CALL
	Televideo TVI-910 Std.	699	CALL
	Lear Siegler ADM 3A	595	CALL
Hazeltine Espirit	507	CALL	
PRINTER	Epson RX80/Graftrax	550	CALL
	Star Micronics G10X	399	CALL
	Comrex CR-1-Q Letter Quality	1200	CALL
	DEC LA 12-A Decwriter	1995	CALL
	NEC 3510 R/O 33CPS Serial	1895	CALL
	Okidata Microline 80	449	CALL
	Olivetti Printer Daisywheel	1745	CALL
	Prowriter Pro I	649	CALL
	Smith Corona TP1-P12	895	CALL
	TI 745 Silent		
	Toshiba P1350F, 160 CPS	2195	CALL
Inforunner Riltan PP-10	499	CALL	
Quime 1140 Daisy Wheel	1681	CALL	
Dialho G20 R-102	1195	CALL	
IDS Microprism	699	CALL	
COMPUTER	Epson OX-10/256	2995	CALL
	Zenith F120-32	5199	CALL
	NEC APC-H01, 128 KB	3795	CALL
	Eagle II	2395	CALL
	Northstar 94404	3599	CALL
Altos 5-15D	2999	CALL	
SOFTWARE	ATI, CP/M-AT1GP/M	75	CALL
	Ati IBM, IBM PC-Dos Op/sys.	75	CALL
	Ashton-Tate DbaseIII-E for Eagle	700	CALL
	Micropro International Super Sort/Apple CP/M	200	CALL
	Wordstar CP/M, Northstar/IBM-PC	495	CALL
	U.S.R. Teljpc	75	CALL
Rixon PC Comi (IBM PC Com Software)	69	CALL	

We have much more products than we can display in this ad, so if you are looking for products not listed above, please check with us first. Since we can guarantee you that we can support any requirements that you might have.

● On Bank Cards add 3%

ORDER TOLL FREE - 1-800-323-2666

TOUMAYAN & ASSOCIATES
115 N. Wolf Rd.
Wheeling, IL 60090
312-459-8866

We Welcome:
● Visa, Mastercard
● Checks
● Company P.O.
● C.O.D. (Add. \$1.50/shipment)

81537, San Diego, CA 92138, (619) 565-8720.

November 5-7

Midwestern Educational Computer & Technology Conference, McCormick Inn, Chicago, IL. Exhibits, software demonstrations, seminars, and workshops will explore the theme "Higher Instructional Techniques in Education." For more information, contact the National Educational Computer Library, POB 293, New Milford, CT 06776, (203) 354-7760.

November 7-11

International Conference on Industrial Electronics - IECON '83, Hyatt Regency Hotel, San Francisco, CA. For information, contact Frank A. Jur, Bechtel Corp., 45 Fremont St., MS-45/17A26, San Francisco, CA 94109.

November 8-10

The Third Annual Software/Expo, Wembley Conference Centre, London, England. Conference topics range from computer-aided design to database management. Contact Software/Expo, Suite 400, 222 West Adams St., Chicago, IL 60606, (312) 263-3131.

November 8-11

Understanding Microprocessor-based Equipment and Troubleshooting, Holiday Inn-Pittsburgh/Sewickley, PA. For details, see October 11-14.

November 8-11

Wescon and Mini/Micro West-83, San Francisco, CA. A conference and exposition, Wescon covers a broad range of topics, including artificial intelligence, computer peripherals and simulation, and robotics. Mini/Micro serves the original equipment manufacturer community by exploring peripherals, processors, data communications, and software. Contact Electronic Conventions Inc., 8110 Airport Blvd., Los Angeles, CA 90045, (213) 772-2965.

November 9-10

Business-Expo, Philadelphia, PA. This exposition serves as a showcase for office equipment ranging from computers to coffee machines. More than 20 seminars are planned. Address inquiries to Business-Expo, 702 East Northland Towers, 15565 Northland Dr., Southfield, MI 48075, (313) 569-8280.

November 9-11

Cryptography and Data Security, Washington, DC. For details, contact Hellman Associates Inc., Suite 300, 299 California Ave., Palo Alto, CA 94306, (415) 328-4091.

November 9-15

Interkama 83, Düsseldorf, West Germany. This exhibition is designed for the instrumentation and automation industries. It's expected to attract more than 1000 exhibitors from over 25 countries. For complete details, contact Düsseldorf Trade Shows, 500 Fifth Ave., New York, NY 10110, (212) 840-7744.

November 11-13

Hometech '83, Exhibition Centre, Bristol, England. Personal computers and related equipment will be displayed. Contact Tomorrow's World Exhibitions Ltd., 9 Park Place, Clifton, Bristol BS8 1JP, England; tel: (0272) 292156.

November 14-17

AUTOFACT 5 Conference and Exposition, Cobo Hall, Detroit, MI. The focus of this event will be on CAD/CAM (computer-aided design/manufacturing) and the expanding technologies of computer-integrated manufacturing and the automated factory. More than 90 companies will exhibit CAD/CAM systems, computer graphics, software, industrial robots, and computer-based test and measurement systems. Concurrent technical sessions and tutorials will be held. Contact Gregg Balko, Society of Manufacturing En-

No more trial-and-error circuit design

MICRO-CAP

Analog Circuit Design Software

By Andrew Thompson, Spectrum Software

Called "a godsend" for the busy engineer by *Softalk*, this amazing software package takes the trial-and-error out of designing electronic circuits. It makes your design work faster... more accurate... and far easier than ever before.

With it, you use your Apple II Plus or IBM PC to draw an analog circuit, then run simulations of its performance under varying conditions. It's like building a breadboard and hooking up signal sources and instruments to see what happens - but much faster and with far less effort. You actually analyze and debug your circuit designs before you build them!

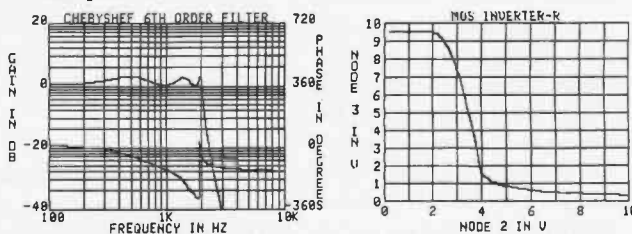

With MICRO-CAP you can easily perform an AC or a DC analysis.

And it's all so simple - no computer expertise is required. For instance, you draw the circuit by just moving a cursor on the CRT screen, and selecting and entering the components (op amps, transistors, capacitors, diodes, etc.) at whatever location you want them placed. When the drawing is finished, the program sets up the equations for the simulation. And completed diagrams can be saved in a diskette file.

You can power your circuit with AC or DC voltages of various values and apply different input signals... run a time-domain simulation of the circuit in operation... perform analyses that show output voltage vs. input voltage and gain and phase shift vs. frequency... and more.

To order - or to get a demo disk - fill in and mail the coupon below.

Machine Specifications: Apple II Plus, 64K, or IBM PC, 128K, and two disk drives

E.T. Matthews, 26th Floor
McGraw-Hill Book Company
1221 Avenue of the Americas
New York, NY 10020



I'm sold! I want to purchase the MICRO-CAP Software Package. Send me an invoice and licensing agreement; I'll then remit the full \$475.00 price, plus local tax. I want the package for (check one):

Apple II Plus IBM PC

I'm interested, but need more information. Send me a demonstration disk, plus detailed spec sheets on MICRO-CAP. I'm enclosing my check for \$19.95 plus local tax for the demo disk - with the understanding that, if I later decide to purchase the complete MICRO-CAP package, this \$19.95 will be credited toward the total \$475.00 package price. I want the demo disk for (check one):

Apple II Plus IBM PC

Name _____

Address _____ Apt. _____

City _____ State _____ Zip _____

Offer good only in USA. 23-D216-4440-3

Event Queue

gineers, One SME Dr., POB 930, Dearborn, MI 48121, (313) 271-1080.

November 14-17

Canadian Computer Show & Conference, International Centre, Toronto, Ontario, Canada. Further information is available from Industrial Trade Shows of Canada, 20 Butterick Rd., Toronto, Ontario M8W 3Z8, Canada, (416) 252-7791.

November 15-17

SNA Architecture and Implementation, Sheraton Rolling Green Inn and Conference Center, Boston, MA. This seminar provides the working knowledge needed to design SNA (system-network architecture) networks and evaluate SNA-compatible products. Examples of how various protocols are used to control communications will be provided. Other topics include SNA functional layering and net-

work elements. The fee is \$650. Full details are available from Communications Solutions Inc., 992 Saratoga-Sunnyvale Rd., San Jose, CA 95129, (408) 725-1568.

November 15-17

The Technical Manager in an Engineering Environment, University of California, Berkeley. This course will deal with practical techniques for efficient management. It will include workshop sessions and clinics focusing on specific problems. The fee is \$645. Further details are available from Continuing Education in Engineering, Department 670N, University of California Extension, 2223 Fulton St., Berkeley, CA 94720, (415) 642-4151.

November 15-18

Understanding Microprocessor-based Equipment and Troubleshooting, Ramada Airport Inn, Rochester, NY. For

details, see October 11-14.

November 17-19

Ed-Com/Fall '83, Los Angeles, CA. This conference and exposition offers demonstrations, seminars, hands-on sessions, panels, and micro courses that address, evaluate, and analyze the development of computers in education. Hardware, software, and publishing companies will display items of interest. Contact Carol Houts, Judco Computer Expos Inc., Suite 201, 2629 North Scottsdale Rd., Scottsdale, AZ 85257, (800) 528-2355; in Arizona, (602) 990-1715.

November 17-19

The Fifth Annual Northeast Computer Show and Software Exposition, Hynes Auditorium, Boston, MA. This end user computer show offers nearly 500 displays of computers, peripherals, accessories, and software. More information is available from Northeast Expositions, 822 Boylston St., Chestnut Hill, MA 02167, (800) 841-7000; in Massachusetts, (617) 739-2000.

November 19

TC/TC: A Teachers College Conference on Teaching with Computers, Teachers College, Columbia University, New York, NY. As many as 60 teachers will present computer-based lessons that they have developed. Lessons include reading, music, art, mathematics, French, composition, and poetry for kindergarten through 12th grade. Workshops will also be featured. Contact the Office of Continuing Education, Box 132, Teachers College, Columbia University, New York, NY 10027, (212) 678-3065.

November 20-22

The Third Annual Purdue On-Farm Computer Use Conference and Trade Show, Purdue University Armory, West Lafayette, IN. Exhibits and demonstrations will be featured.

Contact Stephen J. Resch, Continuing Education Administration, Stewart Center, Purdue University, West Lafayette, IN 47907, (317) 494-2755.

November 20-24

The Third Gulf Computer Exhibition and the Gulf Office Exhibition, International Center, Dubai, United Arab Emirates. These concurrent exhibitions are designed to promote all aspects of computer technology and computer-related office equipment. Information is available from MABCO Inc., Suite 308, 739 Boylston St., Boston, MA 02116, (617) 536-3442.

November 28-December 2

Welcome to the World of Personal Computing, Fort Lauderdale, FL. For details, see October 31-November 4.

November 29-December 2

Understanding Microprocessor-based Equipment and Troubleshooting, Sheraton Greenway Inn, Phoenix, AZ. For details, see October 11-14.

December 1983

December 6-8

The Seventh International Online Information Meeting, Cunard Hotel, London, England. This conference offers presentations that address current problems and opportunities facing those who provide information in business, industry, government, and education. Topics on the agenda include networks, costs of online and videotex systems, software, and user information. Products, services, systems, and publishing organizations will exhibit. Further details are available from the Organizing Secretary, International Online Information Meeting, Learned Information Ltd., Besselsleigh Rd., Abingdon, Oxford OX13 6LG, England; tel:



FEATURES:
16 bit Motorola 68000 CPU operating at 5 MHz or 10 MHz, 20K of on board fast static RAM, 16K bytes of on board EPROM space, 7 autovectored interrupts, 3 memory/device expansion buses, 2 serial communication ports (RS-232 C), 16 bit bidirectional parallel port, 5-16 bit counter/timers with vectored interrupt and time of the day clock. On board monitor allows to download and debug programs generated on APPLE II, TRS-80 and CP/M using our M68000 Cross Assembler.

PRICE:

M68K Bare board with documentation.....	\$ 99.95
M68MON monitor & mapping PROM's.....	\$135.00
MD512 Memory/Disk Contr. (Bare Board).....	\$ 99.95
M68KE Enclosure with P.S. and card cage.....	\$249.95
M68000 Cross Assembler.....	\$149.00
M68K Documentation only.....	\$ 15.00
Shipping & handling (Domestic).....	\$ 4.50
(foreign).....	\$ 20.00

CALIFORNIA RESIDENTS ADD 6% TAX

EMS Educational Microcomputer Systems
P.O. BOX 16115, IRVINE, CA 92713
(714) 553-0133

(0865) 730275; Telex: 837704
INFORM G.

December 6-8

The Software Maintenance Workshop, Naval Postgraduate School, Monterey, CA. Topics of interest include definitions of software maintenance, tools for software and database maintenance, and program evolution. Contact the IEEE Computer Society, Suite 300, 1109 Spring St., Silver Spring, MD 20910, (301) 589-8142.

December 6-8

Business-Expo, Dallas, TX. For details, see November 9-10.

December 6-9

Understanding Microprocessor-based Equipment and Troubleshooting, Capitol Plaza Holiday Inn, Sacramento, CA. For details, see October 11-14.

December 8-11

Southeast Computer Show and Office Equipment Exposition, Atlanta, GA. Contact Dee Harris, Computer Expositions Inc., POB 3315, Annapolis, MD 21403, (800) 368-2066; in Maryland, (800) 492-0192.

December 9-15

Educatec 83, Porte de Versailles, Paris, France. This is the first French exhibition of computerized teaching and training equipment, materials, and techniques. Meetings, symposiums, and debates on educational technologies and professional training will be held. For details, contact Edit Expo International, 4 rue de Chéroy, 75017 Paris, France; tel: (1) 294 05 60; Telex: 641284 F EDIXPO.

December 12-15

Conference on Human Factors in Computing Systems—CHI '83, Boston, MA. Papers, sessions, and tutorials will focus on system usability.

Additional information is available from Raoul N. Smith, GTE Laboratories, 40 Sylvan Rd., Waltham, MA 02254, (617) 466-4044.

December 14-15

Hi Tech Update '83, Delta Ottawa Hotel, Ottawa, Ontario, Canada. An annual update on state-of-the-art high technologies. Contact Marg Coll, 1138 Sherman Dr., Ottawa, Ontario K2C 2M4, Canada, (613) 225-4229.

December 15-16

Personal Computer Local Networks, San Francisco, CA. This is the final program in the four-part Architecture Technology Corporation 1983 Forum Series. This program will bring together manufacturers and users of local network schemes to exchange information in an informal setting. The format includes presentations, panel discussions, and a technological summary. The fee is \$395. For further information, contact the Architecture Technology Corp., POB 24344, Minneapolis, MN 55424, (612) 935-2035. ■

In order to gain optimal coverage of your organization's computer conferences, seminars, workshops, courses, etc., notice should reach our office at least three months in advance of the date of the event. Entries should be sent to: Event Queue, BYTE Publications, POB 372, Hancock, NH 03449. Each month we publish the current contents of the queue for the month of the cover date and the two following calendar months. Thus a given event may appear as many as three times in this section if it is sent to us far enough in advance.

BYTEK's SECOND GENERATION UNIVERSAL (E)PROM PROGRAMMER—SYSTEM 15

Features:

- Bipolar PROMS.
- Micros - (8741, 48, 49, 51, 55A)
- I/O - 6 baud rates, 13 formats including Intellec, Textronix and Motorola.
- EPROMs, (2708 - 27256)
- Gang option - programs eight at once.
- Remote control standard.

\$15-R
\$695

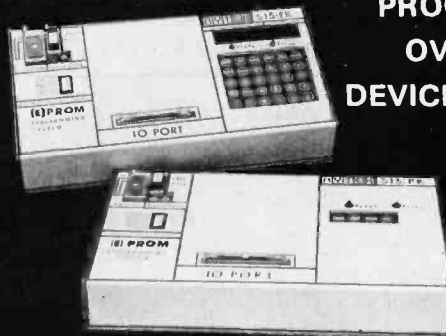

**PROGRAMS
OVER 250
DEVICE TYPES**

FUNCTIONS:

- | | |
|---------------------|-------------------|
| DISPLAY DEVICE DATA | CRC-RAM |
| EDIT RAM DATA | LOAD DATA |
| DEVICE PROGRAM | COMPARE FIELDS |
| TYPE SELECTION | FILL MEMORY FIELD |
| | BLOCK MOVE |
| | DIAGNOSTICS |
| | and more. |



COMPUTER SYSTEMS CORP

4089 S. Rogers Circle #7 Boca Raton, FL 33431 (305) 272-2051

And then there were none.

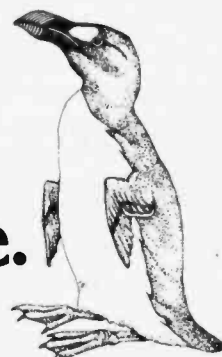

The list of already extinct animals grows . . . the great auk, the Texas gray wolf, the Badlands bighorn, the sea mink, the passenger pigeon . . .

What happens if civilization continues to slowly choke out wildlife species by species?

Man cannot live on a planet unfit for animals.

Join an organization that's doing something about preserving our endangered species. Get involved. Write the National Wildlife Federation, Department 105, 1412 16th Street, NW, Washington, DC 20036.



It's not too late.

What's New?

UNIX AND UNIX-RELATED PRODUCTS

Unix Benchmarks Measure System Performance

Aim Technology markets a portable Unix Benchmark tape to OEMs and manufacturers. This benchmark, which measures actual end-user throughput and multiuser performance, consists of nine distinct tests made up of shell scripts with C language programs that run unattended in any Unix-based system. Each test prints comparative graphs and raw measurements. The Benchmark tests Version 7 Unix command-list completeness, C compiler efficiency, and several aspects of hardware performance applicable to Unix Version 7 and System III. Measurements of the central processor include looping and floating-point calculations. The benchmark examines disk transfer speeds for various record lengths. Compiler optimization is probed for short, integer, and long types. Memory/paging throughput and interprocess communications are measured. Multiuser performance is examined for simulated multiple users doing sorting and editing.

The tests are provided on nine-track, 1600-bpi "Tar" tape with documentation and sample benchmarks. The entire process takes approximately 45 minutes; about 15 pages of reports are produced. For licensing information, contact Aim Technology, Suite

199, 3333 Bowers Ave., Santa Clara, CA 95051, (408) 727-3711.

Circle 650 on inquiry card.

Custom Menu Program for Unix

HCR/Menu Shell lets you custom design menus for Unix. Any text editor can be used to make a file of menus and the associated commands. The menu does not add any overhead to the operating system because it becomes an enhancement to the Unix shell. After your menu is installed, it appears at the top of the screen. The menu structure can be bypassed for direct issuing of commands from the Unix shell. User prompts and restricted access can be written into the menu, and fields can be updated from other programs.

Pricing for the HCR/Menu Shell ranges from \$500 to \$1000, depending upon the central processor to be supported. Further details can be obtained from Human Computing Resources, 10 St. Mary St., Toronto, Ontario M4Y 1P9, Canada, (416) 922-1937.

Circle 651 on inquiry card.

Relational Database Designed for Unix

Unify, a fully relational database designed for the Unix operating system,

provides queries and a purported 10 to 100 percent performance improvement. The performance improvement is achieved through the use of a variety of access methods, such as pointers, hashing, and B-trees, that maximize performance regardless of file structure. A built-in optimizer automatically evaluates each query and selects the expression/evaluation sequence, join order, and access method that will provide the fastest

response. Other features include a choice of user interface components, including query-by-forms, SQL, and a general-purpose driver that allows access to files through either a host language or non-procedural tools.

The single end-user price for Unify is \$2995. OEM and quantity discounts are available. Contact Unify Corp., 9570 Southwest Barbur Blvd., Portland, OR 97219, (503) 245-6585.

Circle 652 on inquiry card.



Unix Workstation Has Built-in C Compiler

Minibox, Heurikon Corporation's multiuser Unix workstation, is built on the MC68000 microprocessor and comes with an integral C compiler. Four or six Multibus cards, single or dual floppy-disk drives, and 31.2 to 140 megabytes of Winchester hard-disk storage are packed into the Minibox, which measures 10½ inches wide, 21

inches deep, and 14½ inches tall. This workstation is built around Heurikon's HK68 microcomputer, which provides the central processor, floppy-disk controller, Winchester and tape interfaces, four to eight serial ports, and 750K bytes of RAM in two Multibus card slots. Minibox has two forward and two rear disk-drive bays. The forward bays can be used for one or two 5¼-inch floppy-disk drives on top of a 5¼-inch Winchester drive. The rear bay can be fitted with one or two 5¼-inch Winchesters.

Up to 420 megabytes of Winchester disk-storage and a graphics card are available as options. Minibox costs from \$12,000 to \$20,000, depending on disk subsystems. For full specifications, contact Heurikon Corp., 3001 Latham Dr., Madison, WI 53713, (800) 356-9602; in Wisconsin, (608) 271-8700.

Circle 653 on inquiry card.

What's New?

Uniflex BASIC Takes Advantage of Unix

Uniflex BASIC 68000 is available for OEM licensing. This system runs under Unix and offers several features that take advantage of Unix. Uniflex, modeled after DEC's BASIC Plus, lets you access system time and date, the running number, and the calling terminal number. Uniflex supports automatic record locking and shared text when these features are available under Unix. Its floating-point mathematics routines provide 16.6 digits of precision, and the built-in mathematics functions are accurate to a minimum of 13.5 digits. An "approximately equal to" operator can be used to compare floating-point values.

File sizes of up to 1 billion bytes are allowed. Three types of files are supported: sequential, record I/O, and random files accessed by virtual arrays. The length of each record can range from 1 byte to 16,383 bytes. Any record in an I/O file can be randomly read or written on request. The data in each record are defined as ASCII characters, binary numeric data, or a combination of the two. Virtual arrays allow a program type to store a data array in a disk file. Other features include an "exec" statement that allows the BASIC programmer to call another Unix program from an executing BASIC program, a mechanism for trapping errors, a compile command that allows BASIC to save programs on disk in a concise form that has a source that

cannot be recovered, and the ability to modify an existing line without retyping. A single command loads BASIC or a specified BASIC program and begins execution of the program.

For more information on Uniflex BASIC 68000, contact Technical Systems Consultants Inc., Providence Rd., Chapel Hill, NC 27514, (919) 493-1451.

Circle 654 on inquiry card.

Directory Lists Unix Software

Onager Publishing has produced a directory of applications software available for the Unix operating system. This directory lists more than 20 categories of software with details on function, cost, size, and availability. Information on manufacturers, such as size and years in business, is also provided.

Onager Publishing service seeks to be a centralized source of Unix information for OEMs and system integrators. For further information, contact Onager Publishing, Suite 204A, 289 South San Antonio Rd., Los Altos, CA 94022, (415) 941-2060.

Circle 655 on inquiry card.

Seminars Cover C and Unix

Three five-day seminars on C and Unix topics are available from Plum Hall for unlimited use within companies. Through a sublicensing agreement, an in-

terested organization that wants to present C or Unix courses to its customers and employees can use these field-tested training materials.

The "C Programming Workshop" is an introductory course for programmers. For experienced C programmers, "Advanced C Topics" covers such subjects as efficiency, portability, and other software engineering topics. Software development is emphasized in the "Unix Workshop," which is designed for introductory audiences.

A single-course, unlimited license costs \$10,000. For more information, contact Plum Hall Inc., 1 Spruce Ave., Cardiff, NJ 08232, (609) 927-3770.

Circle 656 on inquiry card.

Review Serves as Unix Info Center

Unix Review serves as a clearinghouse of information on all aspects of the Unix operating environment as well as Unix-inspired operating systems. It acts as a bridge between the diverse communities of Unix users. It offers research reports, product reviews, user group reports, and featured articles.

Unix Review is produced bimonthly. Annual subscriptions are \$23; overseas subscriptions cost \$43 (surface mail). The newsstand price is \$3.95. For details, contact Review Publications, 2711 76th Ave. SE, Mercer Island, WA 98040, or call operator 965 at (800) 824-7888; in Cali-

fornia, (800) 824-7777. Residents of Alaska and Hawaii can call (800) 824-7919. For residents of Washington state or for retail dealer information, call (206) 232-6719.

Circle 657 on inquiry card.

Multitasking Operating System Compatible with Unix Software

A multitasking operating system that's compatible with Unix software and designed for networking microcomputers has been announced by Lantech Systems. Unetix is a stand-alone system that lets you simultaneously display and work with up to 10 active windows per screen. You can transfer data or text from one window to another, or you can zoom in on a specific window. Unetix also features an emulator to support both MS-DOS and Unix applications software.

Unetix-DFS is the networking version of Unetix. It uses a distributed filing system for transparent remote file and device access. Unetix-DFS is compatible with Plexus Computers' Unix System III Network Operating System. Through Unetix-DFS's virtual terminal capability, you can access the power of an external system. You can also attach portions of file systems from a remote computer to your local file hierarchy. It operates through a high-level communications protocol that's

What's New?

independent of network hardware.

Unitex is also available with a virtual file system. For full details, contact

Lantech Systems Inc., 9625 Wendell Rd., Dallas, TX 75243, (214) 340-4432. Circle 658 on inquiry card.

Product data provided includes information on host system requirements, operating systems supported, special features, and brief product overviews. Vendor data includes company, address, and key contact. The lists are alphabetically arranged

by company. For further details, inquire about catalog number BR126R1 by writing to Motorola Microsystems Inc., Microprocessor Software Catalog, 2900 South Diablo Way, Tempe, AZ 85282. Circle 660 on inquiry card.

PUBLICATIONS

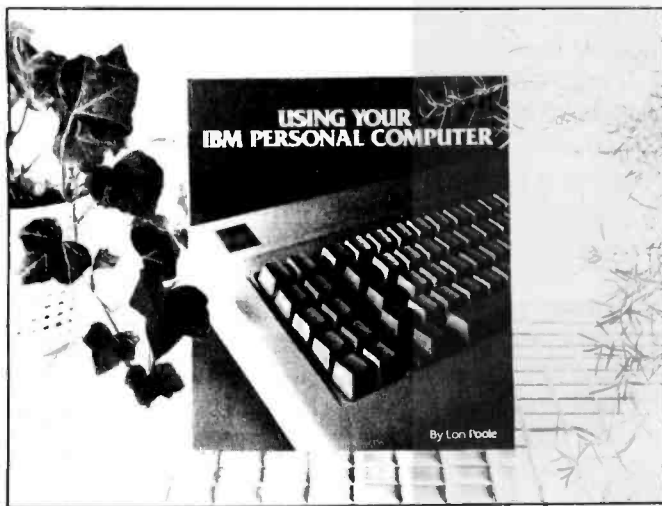

New Book Explains IBM PC Operation

Using Your IBM Personal Computer, by Lon Poole, is a Howard W. Sams & Company publication. Subjects covered in the book include the elements of system configuration, using PC-DOS, and how to boot application programs. BASIC programming and built-in utilities for BASIC programmers are explained. Also discussed are keyboard input, the video-display screen, printer output, disk files, graphics, sound, and control. A 12-page index,

four appendixes outlining commands and codes that are displayed or used with the IBM, and a removable reference card summarizing BASIC and PC-DOS commands are provided.

Using Your IBM Personal Computer is 326 pages long. It costs \$16.95 at most bookstores. For more information, contact Howard W. Sams & Co., 4300 West 62nd St., Indianapolis, IN 46206, (317) 298-5400.

Circle 659 on inquiry card.

VLSI and Systems Interaction Explored

Hardware and Software Concepts in VLSI, edited by Guy Rabbat, explains the interaction between system and chip design. Large-scale embedded systems and the effect of technology on system design are examined. Discussions of microprocessor system architecture focus on the use of VLSI technology, hardware algorithms for string processing, VLSI chip architecture, and VLSI designs based on the use of programmable logic array macro instruc-

tions. Also explored are masterslice bipolar design, computer-aided design methods for gate arrays, gallium-arsenide technology, electron-beam testing techniques for microprocessors, and design verification and logic simulation in VLSI.

Complete with illustrations, this 512-page book costs \$42.50 and can be ordered directly from Van Nostrand Reinhold, Mail Order Service, 7625 Empire Dr., Florence, KY 41042. Circle 661 on inquiry card.

Blue Books on Apple/Commodore Products

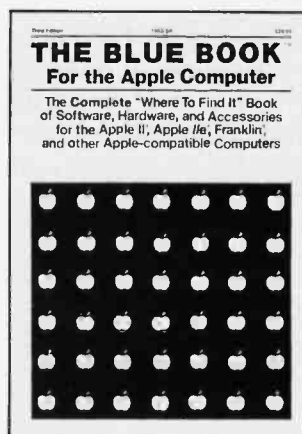

Publications. Both books serve as a directory of hardware, software, and accessories for these popular computers. Source indexes, an alphabetic program index, and keyword indexes are provided.

The Apple Blue Book costs \$24.95, and the Commodore Blue Book is \$17.95. Other editions are available for the Atari and the IBM Personal Computer. Contact WIDL Video Publications, 5245 West Diversey, Chicago, IL 60639, (312) 622-9606. Circle 662 on inquiry card.

The Blue Book for the Apple Computer and The Blue Book for the Commodore Computer are marketed by WIDL Video

Software for 68000 Described in Catalog

The Motorola Microprocessor Software Catalog contains cross-referenced listings of software available for Motorola's 16-bit MC68000 microprocessor.

It provides information on Unix derivatives and look-alikes, non-Unix operating systems, languages, applications and systems software, and cross software.

What's New?

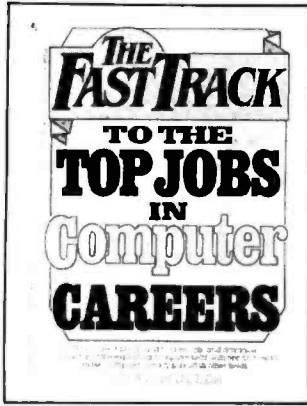

Computer Career Guide

The Fast Track to the Top Jobs in Computer Careers is a beginner's guide by Peter Muller to selecting and pursuing a career in computers. Chapters cover such areas as understanding the field, getting started in high school or college, and change of careers. An appendix of data-processing organizations and associations, a list of career reference sources, and a glossary of computer terms supplement the presentation.

The Fast Track to the Top Jobs in Computer Careers is published by GD/Pedigree Books. It costs \$4.95 and is available at many bookstores or from Redtree Associates, 1740 N St. NW, Washington, DC 20036.

Circle 663 on inquiry card.

Second Edition of Ethernet Handbook Released

The second edition of The Ethernet Handbook has been released. This 532-page, perfect-bound book contains selected product descriptions for

more than 50 vendors, Ethernet 2.0 specifications, and articles on Ethernet, personal computers, and the marketing of Ethernet through retail stores. The components of the Ethernet/personal computer connections are discussed, and case studies and vendor company names and contacts are included.

The Ethernet Handbook costs \$100 (prepaid). It's available from Shotwell & Associates, 130 Golden Oak Dr., Portola Valley, CA 94025, (415) 851-077. Circle 664 on inquiry card.

Micro Review Available on Rolodex

Each month, Educational Micro Review surveys and categorizes more than 400 articles from over 25 microcomputer-related publications. Selections include hardware and software reviews and full bibliographic data. An additional feature of the publication is cross-referencing of hardware and software reviews. The Review is now available on 3- by 5-inch index and Rolodex cards designed for authors and libraries. These cards provide access to articles on specific topics and a means of accumulating an article database.

A year's subscription to the Educational Micro Review costs \$36. The single-issue price is \$5. Rates for the index and Rolodex card versions are \$55 for individual review categories (book, software, and hardware). A full deck costs \$120. Contact Educational

Micro Review, POB 14393, Austin, TX 78761, (512) 345-7739.

Circle 665 on inquiry card.

BASIC/Logo Programming Guide

Written for novice programmers, Dr. James L. Poirot's 40 Easy Steps to Programming in BASIC and Logo uses a learn-by-doing approach. Easy-to-follow steps are said to guide readers through simple Apple II programming exercises.

40 Easy Steps to Programming in BASIC and Logo costs \$3.95 and is available from the Sterling Swift Publishing Co., 7902 South I-35, Austin, TX 78744, (512) 282-6840.

Circle 666 on inquiry card.

Ada Tutorial

Tutorial: The Ada Programming Language contains many of the early papers on Ada and its environment. Designed for engineers and computer scientists, this book covers such topics as the history and current status of the language, how to prevent errors, environments for Ada, and portability. A glossary and bibliography are provided.

Written by Sabina H. Saib and Robert E. Fritz, Tutorial: The Ada Programming Language is published by the Computer Society of the Institute of Electrical and Electronic Engineers, POB 80452, Worldway Postal Center, Los Angeles, CA 90080, (714) 821-8380.

Circle 667 on inquiry card.

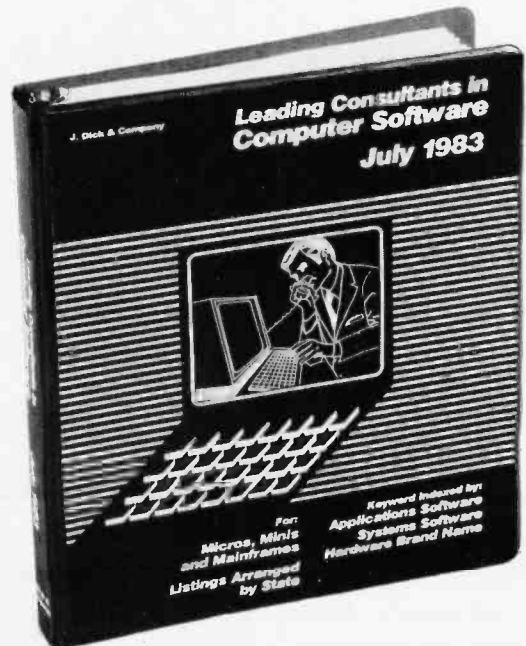

Directory of Software Consultants

A directory of software consultants and custom programmers, Leading Consultants in Computer Software has been com-

plied by J. Dick and Company. This directory lists nearly 1250 consultants, indexed by the computer models and languages

What's New?

with which they work and the applications and systems software in which they have expertise. More than 75% of the consultants are said to offer modem support to their clients. Index listings are arranged by city and state under approximately 850 keywords, ranging from accounts payable to Zilog. Additional data furnished includes address, tele-

phone number, hardware, chips programmed, years of experience, and references.

Available for \$67 (postage paid), *Leading Consultants in Computer Software* can be ordered directly from J. Dick & Co., 500 Hyacinth Pl., Highland Park, IL 60035, (312) 433-0824.

Circle 668 on inquiry card.

Nearly 288 Printer Ribbons Described in Catalog

A 16-page catalog detailing 288 ribbons for computer printers can be obtained from Aspen Ribbons Inc. Photographs and descriptions help users and distributors identify the correct ribbon for the printer. An updated price list is in-

cluded with each catalog. For more information, contact Aspen Ribbons Inc., 1700 North 55th St., Boulder, CO 80301, (800) 525-0646; in Colorado, (303) 444-4054.

Circle 669 on inquiry card.

Magazine Targets Software Writers

The *Software Author* is a bimonthly magazine for writers of computer software. Targeted at both the professional and amateur writer, this publication features market listings of book, magazine, and program publishers. It provides information on copyrights,

interviews with leading authors and publishers, and offers tips on how to be your own publisher. Subscriptions cost \$9.95 and are available from Softwarequest, POB 44122, Tacoma, WA 98444.

Circle 670 on inquiry card.

TERMINALS

High-Performance Graphics Terminal

High-performance business and engineering graphics can be generated with the CGT/680 color graphics terminal from General Digital Industries. The CGT/680, based on the Motorola MC68000

processor, can be used as a stand-alone workstation, a computer terminal, or a CAD/CAM front-end. It uses a 19-inch Panasonic raster-scan CRT. In its graphics mode, up to 16 colors can be displayed

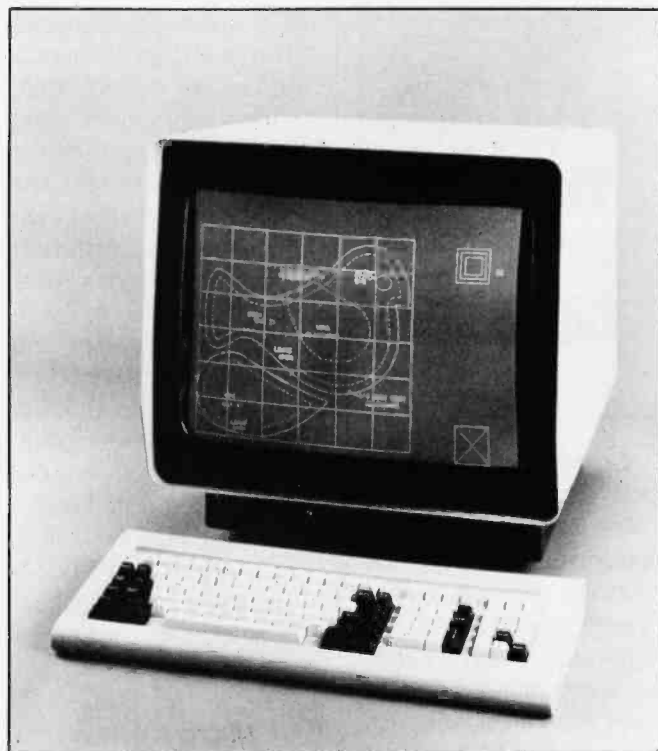

from a palette of 512 in a 640 by 480 format. Look-up tables let you switch colors quickly. Zoom, pan, and blink are standard graphics attributes. For alphanumerics, the CGT/680 gives you displays of up to 48 lines by 80 characters. Attributes include double-height and double-width characters, blink, reverse video, and underline.

System hardware comprises 4K bytes of RAM and 16K bytes of EPROM. A four-slot VME backplane offers two slots for expansion. Two synchronous/asynchronous I/O ports can support SDLC/HDLC protocols.

A low-profile QWERTY keyboard equipped with a numeric keypad, cursor pad, and 20 special-function keys is available. A trackball, touch-sensitive screen, 4K- and 16K-byte memory modules,

SDLC/HDLC protocols, a software-development system, and emulation packages for VT-100, ISC 8001, and Calcomp 960 displays are available as options. Single-unit prices begin at \$4495. Contact General Digital Industries Inc., 7702 Governors Dr., Huntsville, AL 35805, (205) 837-8305. Circle 671 on inquiry card.

Multiposition ASCII Display

An ASCII video-display terminal is available from Prima International. The Prima 30 is a multiposition, tilt-and-swivel pedestal monitor with a low-profile, detached keyboard. Green and amber etched non-glare screens are available. Prima displays 80 characters by 24 lines with a twenty-fifth status line and transmits at speeds of up to 19,200 bps in block or con-

What's New?

versational modes. It emulates Adds Viewpoint, Lear Siegler ADM3A, and Hazeltine 1500 terminals.

Other emulation modes are available. The Prima 30 costs between \$300 and

\$400. For further information, contact Prima International, 3255 Kifer Rd., Santa Clara, CA 95051, (408) 732-4620.

Circle 672 on inquiry card.



Display Aimed at Professionals

The Guru display terminal is aimed at the professional who wants an ANSI-standard terminal with maximum data storage and display capabilities. The Guru provides more than 28K bytes of display memory, or approximately six full typewritten pages, which can be scrolled or zoomed horizontally and vertically. User-selectable memory formats can contain as many as 66 lines of up to 170 columns. A 15-inch nonglare green-phosphor display is used. The detached keyboard features 38 keys programmable on 60 levels with any ASCII string, with local-only, send-only, and repeat control. Smooth scroll,

rapid editing with local move capability, forms-filling functions, pause key, Meta key, and an RS-232C printer interface with local and remote print and copy functions are standard. English identifiers are provided for all setup modes.

Options include a tilt-and-swivel accessory, a portrait display providing vertical screen orientation, a DEC mode for VT100/VT52 software compatibility, and 768- by 600-pixel vector graphics capabilities. The suggested retail price is \$2395. Contact Ann Arbor Terminals Inc., 6175 Jackson Rd., Ann Arbor, MI 48103, (313) 653-8000. Circle 673 on inquiry card.



Monochrome Display Complements Apples

Apple Computer is now marketing a monochrome video display that complements the physical appearance of its Apple II, II Plus, and IIe computers. This 12-inch P31 green-phosphor monitor features high-resolution text and graphics, a high-contrast screen, and a tilt mechanism. Operator controls include contrast, vertical

hold, and vertical amplitude and brightness. The display format is 24 by 80. The suggested retail price is \$229. For the name of your nearest Apple dealer, contact Apple Computer Inc., 20525 Mariani Ave., Cupertino, CA 95014, (800) 538-9696; in California, (408) 973-2042. Circle 674 on inquiry card.

Color Monitors Use Data-Grade Picture Tubes

Two RGB color displays were recently introduced by Panasonic. Both units incorporate data-grade picture tubes and offer full compatibility with Apple II, Panasonic JR-200, and IBM PCs. Common features include built-in audio systems and the ability to generate 16 colors.

A 13-inch (diagonal) RGB/composite display, the DT-D1300D features an

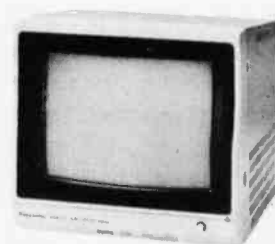

etched, nonglare, dark-faced CRT. It accepts a composite-video input and displays of up to 1000 characters in a 40 by 25 format. Its alternate RGB input features a multipin in-

What's New?

put connector with optional interconnection cables. In the RGB mode, it displays up to 2000 characters in an 80-character by 25-line format. Resolution is 430 by 240 pixels. A looping connector and an on/off switch are provided. The unit costs \$540.

The DT-D1000G 10-inch RGB display has built-in interface circuitry and a

multipin connector. It generates 2000 characters in an 80 by 25 display and offers a resolution of 350 by 240 pixels. A universal power supply is standard. The DT-D1000G lists for \$450. Full details are available from Panasonic, One Panasonic Way, Secaucus, NJ 07094. Circle 675 on inquiry card.

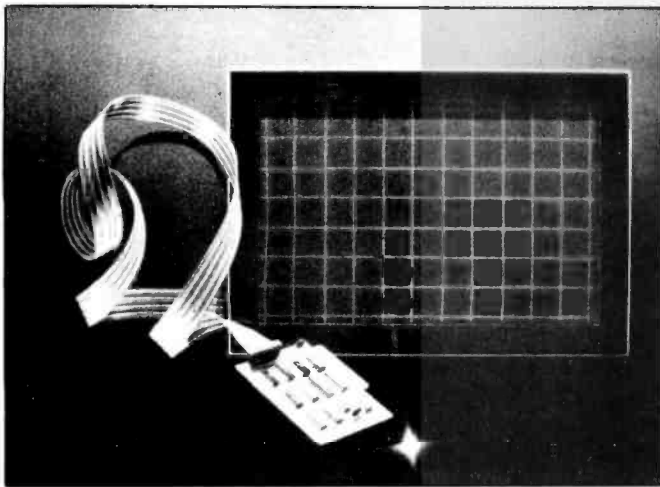

Touch-Sensitive Display for Apples

Computer Technology Associates markets a touch-sensitive display screen for the Apple Monitor III and other 12-inch monitors. The CTA 500X Touch Bezel and Interface provides instantaneous response to onscreen touch commands and is capable of emitting continuous responses for tracking moving stimuli. It uses infrared emitter-sensor array technology and offers 96- by 64-point resolution. The Interface card plugs into an Apple peripheral slot, and, once initiated, the screen remains continually touch-sensitive. All communica-

tions are hardware-controlled; communications software is not required. Applesoft BASIC can read and write the X,Y coordinates of the moving command without modification.

The CTA 500X has a suggested retail price of \$695. Quantity discounts are available. For further information, contact Computer Technology Associates, 1704 Moon NE, Albuquerque, NM 87112, (505) 298-2140.

Circle 676 on inquiry card.

COMMUNICATIONS

Datamizer Doubles Throughput

Datamizer is a multiplexing data-compression unit. When installed between data terminal equipment and a standard 9600-bps modem, it allows twice the volume of data to be transmitted over standard telephone lines at speeds as high as 19,200 bps. Datamizer uses a data-compression algorithm called SCC Tabling, which is an adaptive form of Huffman Encoding. SCC Tabling lets Datamizer analyze any EBCDIC or ASCII data character and convert it to a shorter subcode based on its relative frequency in the data stream. Operating in pairs, one at each end of a full-duplex line, both Datamizers send and receive data while continually updating the SCC frequency table for maximum throughput. The receiving unit uses the frequency information to decode and expand subcodes into standard 8-bit code sets. This method is purported to achieve error-free compression ratios of 2:1 or better. Datamizer is not dependent on communications protocols, nor does it require set-up programming. Its operation is transparent.

Datamizer also serves as a statistical multiplexer, using dynamic band allocation. Each of its four channels can multiplex a different half- or full-duplex protocol at an independent rate. Transmission rates can be divided into two 9600-bps channels or four 4800-bps channels. All four

inputs can be set to 9600 bps, resulting in an aggregate input of 38,400 bps.

In single units, Datamizer costs \$4950. Quantity discounts are offered. Full specifications are available from Symplex Communications Corp., Suite 17, 2002 Hogback Rd., Ann Arbor, MI 48104, (313) 973-1164. Circle 677 on inquiry card.

Communications Board

Voice/computer/telephone communication is possible with the V. C. T. board from Unisound. The communications board is said to give Apple owners access to an unlimited vocabulary, languages, and tonal varieties. It combines the ability to place and receive calls automatically with a Touch-Tone decoder for entering and retrieving data over telephone lines. Six I/O ports let you monitor and control such accessories or interfaces as appliances and security systems. Software for developing and storing speech messages is supplied. An answering-service program and a BASIC interpreter that adds new commands to Applesoft are also furnished.

The V. C. T. board costs \$350. For more information, contact Unisound Corp., 3060 Harding Ave., Santa Clara, CA 95051, (408) 554-6227. Circle 678 on inquiry card.

What's New?

Self-contained Direct-connect Modem

Timecor's Operator, a 110/300-bps direct-connect modem, is hardware-compatible with the Apple II/IIe and II Plus, Franklin Ace 100 and 1000, and the Basis 108. Its foremost features are half-and full-duplex operation, auto-answer and auto-disconnect, and the ability to work with rotary-pulse and Touch-Tone telephones. This self-contained Bell 103-compatible device allows one-way or simultaneous sending and receiving. It fits into any Apple slot except zero and is compatible with such communication software as ASCII Express Pro, Visi-term, Modem Magic II, and Z-Term.

The Operator, available factory-direct for \$159.95, comes with documentation and start-up software. Contact Timecor, Four Longfellow Place, POB 8928, Boston, MA 02114, (617) 720-4090. Visa and Master Card owners can order by calling (800) 824-7888, operator 52. Circle 679 on inquiry card.

Web Network for Kaypro

The Web lets you weave Kaypro computers into a network. Each computer in the network acts as a file server as well as a local processor, and any linked user can share data stored on the disk drive of another Kaypro or direct output to a remote printer. Users can send and receive mail, messages, and files,

log on to drives on another machine, and run programs. The Web is a base-band CSMA/CD-CA network operating at just over 125,000 bps. Connections are made with conventional telephone cables. OPSnet, the networking software, supports most CP/M 2.2 programs.

Web can be configured using any combination of

Kaypro computers, including the II, 4, 10, and Kaynet, which has built-in network capabilities. Complete with manual, hardware, cables, and software, the networking option costs \$195. For more information, write to Kaypro Corp., POB N, Del Mar, CA 92014.

Circle 680 on inquiry card.

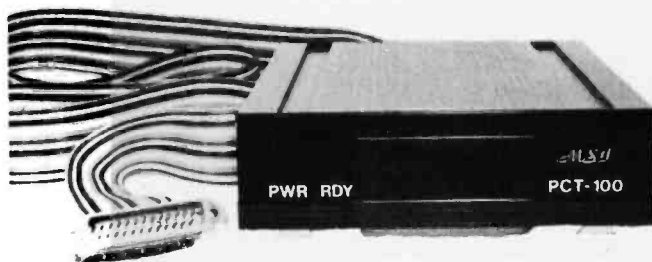

RS-232C Interface Has Communications Language

Method Systems' PCT-100 is a user-configurable RS-232C interface with an internal communications translator language—called CTL—that lets you configure the interface to perform most translation algorithms. The PCT has two bidirectional RS-232C ports that allow it to be placed inline with any RS-232C link. It can be used for terminal or printer emulation or for providing compatibility and macro function keys for word processing, accounting, and other software. It offers type-ahead and data buffering capabilities, data-rate adaptation, and handshake protocol conversion.

Offered as a ready-to-install printed-circuit board or as a stand-alone unit, the PCT-100 costs \$369,

without power supply. Contact Method Systems Inc., 19751 South Lakeshore Blvd., Euclid, OH 44119, (216) 531-0404.

Circle 681 on inquiry card.

IBM PC XT Local-Network Scheme

Novell's Sharenet X allows as many as 255 IBM PC XTs to share up to 320 megabytes of storage. The network protocol is CSMA/CD (Carrier Sense Multiple Access), and the data-transfer rate is 1.43 megabits per second. The Sharenet operating system provides the file server with support for multiple DOSes sharing the network and file space, a means for managing the functioning

of multiple computers in the same directory simultaneously, file security, and support of spooled printers and station-to-station pipes. A single 256K-byte IBM PC XT functions as a file server in the Sharenet scheme, and each satellite must be equipped with a network interface module. Maximum linear coaxial (RG59) cable length is 4000 feet.

Electronic mail is available as a \$995 option. The operating system costs \$1495, and network interface modules are \$695. For an information packet, contact Novell Inc., 1170 North Industrial Park Dr., Orem, UT 84057, (800) 453-1267; in Utah, (801) 226-8202.

Circle 682 on inquiry card.

Microcom Networking Protocol

The Microcom Networking Protocol (MNP) is said to be the first data-communications protocol to allow file transfer to and from a variety of microcomputers over ordinary telephone lines. The protocol, based on the Open Systems Integration (OSI) model, features flow-control, data transparency, error detection, and retransmission. The architecture provides reliable, flow-controlled data transfer on point-to-point connections. Data can be transferred both as streams of bytes and as files. The encoding protocol information is byte-oriented throughput, which facilitates implementation of MNP in program-

What's New?

ming languages on computers that do not provide bit manipulation. The file-transfer protocol is inherently half-duplex or command responsive. The hardware requirements are a 212A or 103 modem and voice-grade telephone cables.

Currently, the MNP protocol has been employed on such computers as the Apple, the Radio Shack, and the IBM PC. It has also been used in Microcom's line of networking modems. MNP is available for a \$2500 licensing fee. Full particulars can be obtained from Microcom Inc., 1400A Providence Highway, Norwood, MA 02062, (617) 762-9310. Circle 683 on inquiry card.

Database Covers Industrial-Site Development

Sitenet is a free online database delivering instant site data to industrial facility planners and corporate real estate executives. Sitenet's files contain information on tax incentives for industrial development, more than 5000 contacts in area economic development, and a directory of office and industrial parks. A new-plant file provides data on more than 1000 worldwide industrial expansion projects and details on the amount of investment, acreage, and square footage of the undertakings. An interactive inquiry mode lets you request additional information online from development corporations participating in the network.

Blocks of information provided by state development agencies, railroads, and utilities are available. Hard-copy reports from the database can be ordered.

For more information, contact Conway Data Inc., 1954 Airport Rd. NE, Atlanta, GA 30341, (404) 458-6026.

Circle 684 on inquiry card.

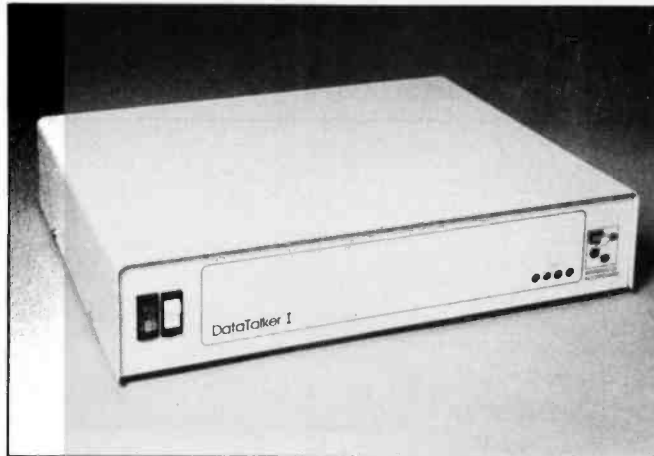

Intelligent Communications Processor

Winterhalter's DataTalker I is an intelligent front-end communications processor for emulating such remote batch and interactive terminals as the IBM 3780, 2780, and 3276 using IBM Binary Synchronous Protocol. It contains two network programs for interactive and remote batch emulation, both of which offer full bisync emulation and on- and offline diagnostics. A communications manager assumes responsibility for controlling the line between the microcomputer and the host system. An applications program, executed on the microcomputer, acts as an interface between the microcomputer and DataTalker and allows custom user programs to interface with the host. This arrangement frees the microcomputer of

all communications overhead and overloads.

DataTalker hardware consists of one modem port, a diagnostics port, and an asynchronous serial link with internal clock generation. All ports are RS-232C serial interfaces. The modem and diagnostics ports can be programmed for internal or external clock generation and are byte or bit synchronous or asynchronous. Internal clock speeds range from 110 to 19,200 bps.

The DataTalker I is a desktop unit that weighs about 7 pounds. The suggested list price is \$995. Further details are available from Winterhalter Inc., 3853 Research Park Dr., Ann Arbor, MI 48104, (313) 662-2002.

Circle 685 on inquiry card.

Apple/Atari Interface

Prowell Computer Services markets an interface that allows disk files to be transferred between Atari 400/800 and Apple II, II Plus, and IIe computers. A cable that connects to the joystick ports on both computers provides the means for sending and receiving source programs and data files.

The interface comes in two versions. The Model 1 is designed for the Apple II/II Plus. The Model 2 includes the cable and a 9-pin connector that mounts on the back of the IIe. They cost \$75 and \$90, respectively. A 4-foot extension cable is also available. Contact Prowell Computer Services, Suite 325, 4974 North Fresno, Fresno, CA 93726, (209) 227-4917.

Circle 686 on inquiry card.

Arcnet-PC Network Controller

The ARC-PC local-area network controller board is a simplified interface between IBM Personal Computers and Datapoint's Arcnet token-passing network. Standard Microsystems' single-chip COM 9026 network controller and COM 9032 network transceiver LSI circuits handle Arcnet protocols. This single printed-circuit board has an onboard 2K-byte data-packet buffer that accommodates up to four pages of packet storage and can be dynamically defined for double-buffering of transmit and receive

What's New?

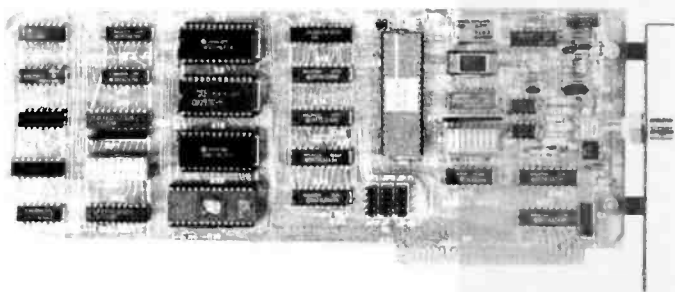

functions. An 8253 programmable interval timer lets you program timeouts. For your programs, the ARC-PC has sockets for 8K-byte PROMs and 2K-byte RAMs. ARC-PC supports up to 255 nodes per network segment

while running at 2.5 megabits.

In quantity, the ARC-PC costs \$495. Contact Standard Microsystems Corp., 35 Marcus Blvd., Hauppauge, NY 11788, (516) 273-3100.

Circle 687 on inquiry card.



Transmit Two Terminals on One Line

The Model 2X212 Modemplexer, a two-channel statistical multiplexer and modem in a single package, is manufactured by Omnitec Data Inc. This 212A- and CCITT V24-compatible, full-duplex 1200-bps device can transmit data from two remote terminals on a single line, reducing telephone expense and network hardware overhead. Salient features include auto-answer/dial, automatic redial, and automatic selection of appropriate dialing modes. AT & T-licensed

and FCC-approved, this unit also provides speed dialing, up to 10 stored numbers, continuous memory, dynamic buffering of up to 3000 characters for both its RS-232C ports, flow control, user-programmable disconnect code, and selectable parity.

The Model 2X212 Modemplexer costs \$995. For more information, contact Omnitec Data Inc., 2405 South 20th St., Phoenix, AZ 85034, (800) 528-8423; in Arizona, (602) 258-8244.

Circle 688 on inquiry card.

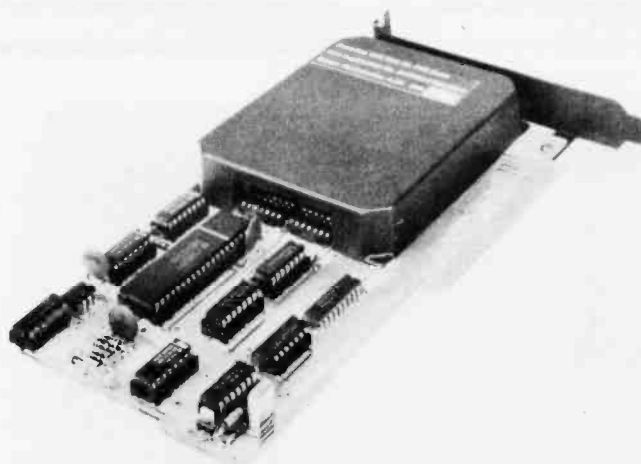

300-bps Modem Mounts in IBM

Avcom's 300-bps PM-300 originate/answer modem mounts inside the IBM Personal Computer. An auto-answer function lets you select the number of rings before pick up. This modem will dial out with a Touch-Tone or rotary pulse in any combination. The PM-300 does not require an RS-232C card or connectors.

The PC-300 is compatible with Bell-103 standards and with Avcom's Compac and other IBM communications software. Compac is a videotex program

that supports asynchronous communications. It provides automatic log-on and file download and upload capabilities under error-correcting protocol. Data received can be entered into a disk file or buffer and displayed, printed, or transmitted.

The PC-300 with Compac costs \$249.95. The software alone is \$69.95. Details are available from Avcom Inc., POB 29153, Columbus, OH 43229, (614) 882-8176.

Circle 689 on inquiry card.

Network Driver Hybrid

The Zenith LAND (Local Area Network Driver) Hybrid is a highly reliable interface for such local-area networks as Datapoint's Arcnet. Standard features include a 20 single inline pin configuration, -5 or -12-volt drive, noise immunity and filtering for interference-free data travel for up to 2000 feet of coaxial cable, and a physical layer implementation for interfacing with most net-

work technologies. Zenith offers design and production capabilities to tailor or customize LAND to individual specifications. LAND is available with a straight lead frame or with a right-angle lead frame. For more information, contact Zenith CRT & Components Operations, 1000 Milwaukee Ave., Glenview, IL 60025, (312) 391-7733.

Circle 690 on inquiry card.

What's New?

PERIPHERALS

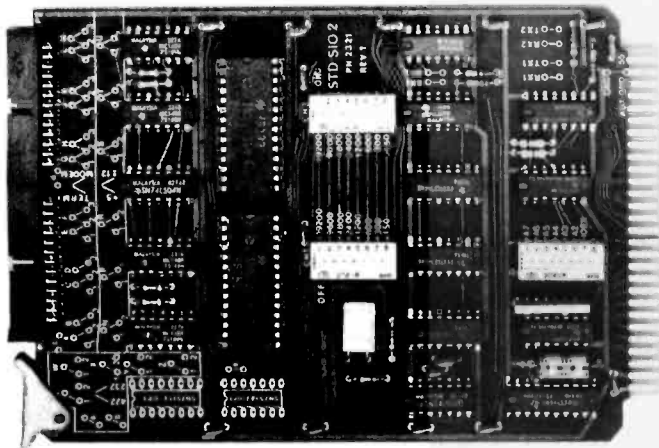

Independent Serial Channels

Both channels on the STD SIO-2 RS-232C serial interface board have independent switch-selectable data rates so that you can change transmission speeds without reprogramming the board or modifying system software. These channels offer fully buffered asynchronous operation at speeds ranging from 150 to 19,200 bps. Polled or inter-

rupt modes, terminal or modem-type connection, and switch-selectable board addressing with I/O expansion bit are standard.

An RS-422A channel is optional. The STD SIO-2 costs \$185 (two to nine units). Contact Forethought Products, 87070 Dukhobar Rd., Eugene, OR 97402, (503) 484-8575.

Circle 691 on inquiry card.

Tektronix Emulation for the Esprit III

The E-III Graphics Controller gives the Esprit III terminal full Tektronix 4010 emulation capabilities. Tektronix Plot 10 software-compatible, the E-III offers two alphanumeric modes: 24 by 80 or 35 by 73. Both modes can be activated from the keyboard or from the host computer. Other features include automatic vector drawing for creating bar charts, pie diagrams, and histograms.

The E-III Graphics Controller costs \$625. It's available factory-direct from ISM

Inc., Jackson Place South, Suite 6, 932 Hungerford Dr., Rockville, MD 20850, (301) 279-5775.

Circle 692 on inquiry card.

Host-Independent In-circuit Emulators

Real-time, transparent emulation of 8086, 8088, and 80186 microprocessors is available through Microcosm's M(x) family of host-independent in-circuit emulators. The M(x) line of emulators consists of an

Emulation Module that connects to a Probe Module containing target-system interface circuitry. These emulators communicate with a host system, such as the IBM PC, through a standard RS-232C serial interface and host-specific software. System hardware includes trigger recognition, event recognizers (i.e., processor address, processor data and status, and logic module signals), user-selectable emulation clock, and 8K bytes of parity-protected RAMs. Programmable wait states, three trace modes, diagnostics, and a software interface with menus, high-level command language, and utilities are standard.

Options include memory expansion and communication and logic modules. Complete specifications are available from Microcosm Inc., 1679 Enterprise Plaza, POB 624, Hillsboro, OR 97123, (503) 648-6500.

Circle 693 on inquiry card.

or bit- and byte-oriented synchronous formats at speeds ranging from 110 to 19,200 bps. This hardware/software combination has a pattern-match trigger with pre- and post-trigger capabilities. Data capture of up to 4K bytes with floppy-disk storage and retrieval is possible, and a programmable host-emulation mode allows the Apple to function as a communications controller capable of generating polling sequences with reply. Metascope will generate synchronous clock signals in the host-emulation mode, eliminating the need for modem emulators. Half- and full-duplex displays and ASCII, EBCDIC, and hexadecimal display formats comprise its other abilities.

Metascope works with Apple and Franklin computers. With documentation and software, it costs \$895. Contact Metatek Inc., 12525 Hummingbird St. NW, POB 33129, Minneapolis, MN 55433, (612) 571-7319.

Circle 694 on inquiry card.



Data Line Monitor

Metascope, a high-performance data line monitor, can display and store data in asynchronous

Physics Lab Interfaces

Cross Educational Software has introduced physics lab interfaces for classroom experiments. The interfaces, Heat, Light, and Sound, are designed for the Apple. They come with a kit of parts that connect to the Apple game port, a disk for calibration, and documentation for several experiments. Each program costs \$60.

What's New?

Light experiments include timing a pendulum, measuring the acceleration of gravity, measuring light intensity, and the efficiency of a light bulb. Four phototransistors are provided. Graphing temperature versus time, thermal radiation, cooling curves, and specific heat make up the Heat experiments. Heat comes with four thermistors. Sound experiments involve sound intensity, simulated oscilloscope, and Fourier spectrum analyzer. A speaker, microphone, potentiometer, transistors, and a capacitor are provided.

For more information, contact Cross Educational Software, POB 1536, Ruston, LA 71270, (318) 255-8921.

Circle 695 on inquiry card.

IBM Color Graphics System

The Cono#Graph color graphics system for the IBM PC is made up of the Cono#Graph Adapter, the Cono#Gen graphics-processing module, and Cono-Lib software. The Adapter substitutes for the IBM graphics card and provides 256 colors from a palette of 16. It supports resolutions of 320 and 640 by 200; the alphanumeric modes are 80 or 40 by 25. It comes with 128K bytes of graphics memory and IBM-compatible character and graphics modes. As many as four graphics pages can be achieved, depending upon display resolution. Each page may be selected for display and,

while one is displayed, the others may be modified. The Cono#Color Adapter has a light-pen interface capable of resolving ± 1 pixel and an interface to the Cono#Gen graphics processor.

Featuring a dedicated Motorola 6809 processor, Cono#Gen has high-speed hardware generators for vectors, circles, ellipses, and conic curves at speeds up to 800,000 pixels per second. It provides a 2K by 2K addressable area, rectangle fill, and line texturing. It's supplied with Cono-Lib, an extensive library of subroutines for scaling, rota-

tion, fill, image creation, labeling, and recall. Cono-Lib runs under PC-DOS and works with Pascal, BASIC, C, FORTRAN, or assembly language.

The complete Cono#Graph system fills a single IBM expansion slot. The Cono#Color Adapter is \$895. Cono#Gen costs \$745, including the software. The software alone is \$125. Full details are available from Conographic Corp., 2268 Golden Circle, Newport Beach, CA 92660, (714) 650-2666.

Circle 696 on inquiry card.

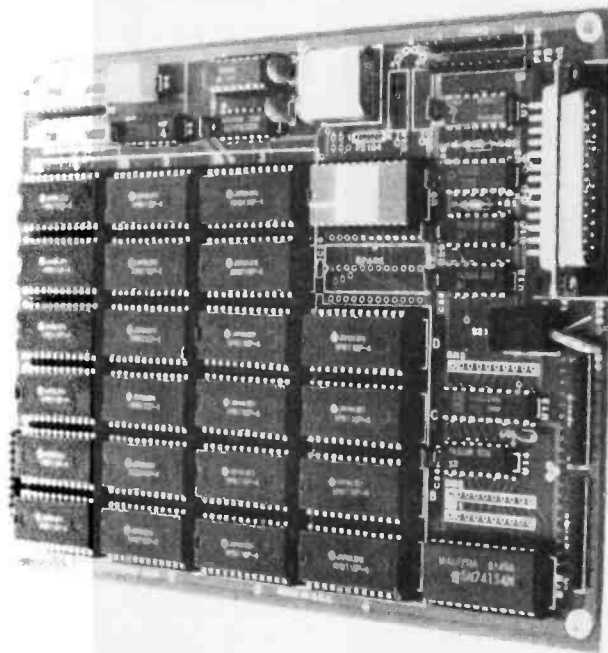

Add-ons Enhance Hero's Image

Perbotics markets three add-ons for Heath's Hero I robot: an 8K-byte RAM/communications board, a 44K-byte RAM/communications board, and a software package. The 8K-byte RAM comes with 20 sockets for individualized

expansion, while the 44K board incorporates an RS-232C-compatible port that lets the Hero communicate with a computer. Perbotics' cassette-based software provides load and dump routines for downloading and storing pro-

grams through the RS-232C port and a memory verification routine.

The 8K- and 44K-byte boards cost \$395 and \$795, respectively. The software is \$49. Order these products factory-direct from Perbotics, 211 Costa Mesa St., Costa Mesa, CA 92627, (714) 845-9294.

Circle 697 on inquiry card.

CP/M Processor Works with TI 99/4A

The Morning Star CP/M Processor gives TI 99/4A owners the ability to run CP/M programs. This device contains a 5-MHz 8085 microprocessor, 64K bytes of RAM, and an 8K-byte operating system. Connections are made by slipping the CP/M Processor into the TI 99/4A's expansion box.

The CP/M Processor costs \$595. For full details, contact Morning Star Software, 4325 109th Ave., Beaverton, OR 97005, (800) 824-2412; in Oregon, (503) 646-4695. Circle 698 on inquiry card.

Device Guards Entry to Computers

Lineguard 3000 from Western Datacom intercepts all incoming computer access calls and requests identification codes from callers. Lineguard searches its memory to verify code numbers and denies access to the computer if its search proves fruitless. If the verification is completed, Lineguard calls

What's New?

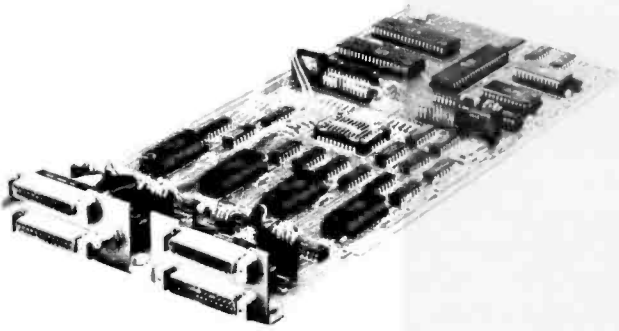

back and connects the caller to the computer. Communication is through the caller's display. Lineguard scans two incoming lines and is compatible with asynchronous dial-up modems and protocols. Failed entry attempts are

permanently recorded for evaluation.

Lineguard costs \$945. For more information, contact Western Datacom Co., 5083 Market St., Youngstown, OH 44512, (216) 788-6583. Circle 700 on inquiry card.

SOFTWARE

Leading Edge of IBM PC Word Processing

The recently introduced Leading Edge Word Processor for the IBM Personal Computer is said to be easy to learn. Priced at less than \$300, this word processor lets you print your documents in color. Standard editing features include single-keystroke character or block insert, delete by character or block, delete recall, and search and replace. You can set tab stops, margins, spacing, page length, and pitch and place format lines anywhere in a document. A split-screen feature lets you review more than one document on the same screen.

Also standard are the ability to insert date or time in text, a change-case mode that permits altering a character from uppercase to lowercase or vice versa without retyping, transposition of characters for reversing common typos, and the ability to jump to any page in a document. One built-in feature lets you move the cursor by character to the beginning or end of the document; you can also move the cursor by previous or next word, line, sentence, screen, or page.

Text attributes include indent, reverse indent, center column, decimal tabs, and word wrap. Boldface, double-width characters, strike-through, super- and subscripts, underline, double underline, a variety of character fonts, and justi-

fied type are among the print features available. You can print a text screen, sections of a text screen, or an entire document.

For complete details, contact Leading Edge Products Inc., 21 Highland Circle, Needham Heights, MA 02194, (800) 343-3436; in Massachusetts, (617) 449-4655. Circle 702 on inquiry card.

Modula-2 for IBM PC

Modula-2 for the IBM Personal Computer is available from Volition Systems. This version uses standard software modules and separate compilation with automatic control. It comes with a comprehensive module library, a compiler, and tutorials. Modula-2 features low-level machine access, real-time control, concurrent processes, and type-secure separate compilation with automatic version control. Highlights include communication between the compiler and editor, which reduces development time, dynamically linked modules, and a user-friendly interface and prompts. Real-number and transcendental mathematical support are provided by the 8087 numerics processor, and interrupt-handling is fully supported. The Modula library provides console I/O, random-access files, disk-directory operations, format conversion, strings, decimal arithmetic, storage management, program execution, and process scheduling. Programs written in Volition Systems' Modula-2 are



Weather Sensing Package

HAWS, Home Automatic Weather Station, is designed for the Commodore 64 and VIC-20. HAWS has an external sensing device that lets you monitor weather conditions inside or outside your home. You can interact and analyze input for predicting changing weather conditions and rating your forecasting abilities.

HAWS costs \$199.95, complete with sensor, cassette or floppy-disk software, connecting cable, and manual. Address dealer and customer inquiries to Vaisala Inc., Consumer Products, 2 Tower Office Park, Woburn, MA 01801, (617) 933-4500. Circle 701 on inquiry card.

What's New?

said to be directly portable from the IBM PC environment to the Apple.

Volition currently supplies Modula-2 for the Apple II under Apple Pascal, the Apple III running SOS, and as part of a complete software system for computers based on 8080/280 and 68000 microprocessors. The complete Modula-2 system for the IBM PC includes Pascal and Modula-2 compilers, a module library, an advanced system editor, a p-NIX command shell that provides a Unix-like programming environment, and a set of utility programs. It costs \$595; educational, retailer, and distributor discounts are available. Contact Volition Systems, POB 1236, Del Mar, CA 92014, (619) 481-2286.

Circle 703 on inquiry card.

dividualized printout assessing the respondent's health is produced. Advice is offered on how to reduce health risks outlined in the report.

Wellness Check is written in BASIC and runs on Apple II Plus/IIe, IBM PC and PC XT, and Radio Shack TRS-80 Model II, 12, and 16 computers. It costs

\$250, which includes complementary educational materials for adults and teenagers. It can be ordered from the Office of Health Promotion, Rhode Island Department of Health, 75 Davis St., Providence, RI 02908, (401) 277-6957.

Circle 704 on inquiry card.



Word Processor and Database Manager for Commodore 64

Mirage Concepts is marketing a word processor and a database manager for the Commodore 64. The database manager will store, search, sort, retrieve, display, calculate, and print reports, lists, and mailing labels. It features free-form design and input, the ability to sort on any field or level, calculated fields, and system parameters large enough for most file functions. It can accommodate 65,535 records per file, 2000 characters and 200

fields per record, and 250 characters per field.

The word processor produces an 80-column display without additional hardware. It has true word-wrap, more than 70 single-stroke commands, search and replace operations, block functions, macro instructions that permit it to work with a variety of printers, and printed page, line, and character counters. Text can be formatted onscreen exactly as it is to appear in hard copy.

A high-resolution monitor is recommended but not required.

Both programs are written in machine language and interface with each other. The suggested list price for each program is \$99, including documentation with tutorials. For additional information, contact Mirage Concepts Inc., Number 106, 2519 West Shaw, Fresno, CA 93711, (202) 227-8369.

Circle 705 on inquiry card.

CP/M Recovery Program

Lion Micro Systems' CP/M Recovery eliminates data and text loss in computer memory due to system crashes, program or operator errors, failure to back up, and disk failures or unexpected full-disk conditions. This user-friendly program lets you recover memory, conduct editing on data within memory (including control characters), and save data to a disk file.

CP/M Recovery works with single- or multiuser systems. It costs \$99 and is available from Lion Micro Systems / In-Sync Systems Inc., Suite 501, 1900 Pacific Ave., Dallas, TX 75201, (214) 760-9120.

Circle 706 on inquiry card.

Spelling Teacher

A program called Spelling Teacher for the NEC PC8000 can be ordered directly from Computech. For each session, the program confronts your child

Health Check Offers Advice

A computerized health-risk-appraisal program designed to make individuals more aware of the difference various health risks can make in their lives is available from the Rhode Island Department of Health. The Wellness Check is suitable for use in hospitals, state and local health departments, companies, schools, and health maintenance organizations. It consists of a questionnaire covering a broad range of lifestyle topics. Responses to the questionnaire are fed into a computer, and within a few minutes an in-

What's New?

with 25 spelling problems. Misspelled words are the first words presented during the next session. The program contains a password security system and four word files, each representing a different skill level. Word files can be changed and modified. Program options include the ability to display a bar chart representing the

scores of the last 10 sessions.

The Spelling Teacher requires one disk drive, 32K bytes of memory, and a monochrome or color display. It costs \$39.95 and can be purchased from Computech, POB 7000-309, Redondo Beach, CA 90277.

Circle 707 on inquiry card.

IBM Personal Computer and PC XT is written in Microsoft BASIC and operates under PC-DOS. Available packages include general ledger, accounts payable with check writing, accounts receivable with billing, inventory control and management, payroll with check writing, and fixed assets/depreciation. All Certiflex packages are menu-driven and compatible with XT, Davong, Corvus, and other hard-disk drives. These programs are said to be designed by certified public accountants for operation by individuals with no prior computer experience.

The suggested retail price for each package is \$549, which includes a manual, telephone support, and a two-year warranty. For the name of your nearest Certiflex dealer, contact Computer Program Associates, 2526 Manana Dr., Dallas, TX 75220, (214) 350-2361.

Circle 709 on inquiry card.

Matchpoint/86 does not require hardware alterations or conversion equipment because it resides in 8K bytes of RAM. It works with floppy or hard disks. The suggested retail price is \$99. For more information, contact American CompuSoft, 23113 Plaza Pointe Dr., Laguna Hills, CA 92653, (800) 235-7049; in California, (800) 235-2394 or (714) 472-8186.

Circle 710 on inquiry card.



Home Management Series

A home management system from Douthett Enterprises, Silversoft comprises budget, calendar, word processing, and personal portfolio programs. Each program runs on 128K-byte IBM Personal Computers and offers self-documenting prompts and error messages. The Silver-budget program is a double-entry accounting system with 240 categories, unlimited transactions, and check reconciliation. It can handle multiple checkbooks and features a flexible search function and transaction calendar. Silver-calendar provides multidimensional scheduling of

240 appointments. It locates time conflicts, available time, and automatically repeating appointments.

The Silverwriter word processor can create mailing lists and build Micropro Wordstar- and Mailmerge-compatible files. It indexes by first and last name, city, state, zip code, or country, and it can merge letters and reports with mail lists.

Silverfolio's complete portfolio of personal worth and a range of financial functions lets you keep a descriptive inventory of insurance policies, personal property, stocks, assets, real estate, and valuables. In addition, it can produce net-worth statements and amortization schedules.

Each program works with floppy- or hard-disk drives and requires a printer and CP/M-86. Contact Douthett Enterprises Inc., Suite 1, 906 North Main, Wichita, KS 67203, (316) 262-1040.

Circle 708 on inquiry card.

Accounting for the IBM PC

Certiflex Business Accounting Software for the

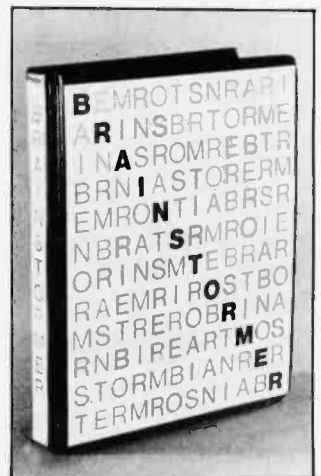

Brainstorm Your Way Through Problems

Soft Path Systems' Brainstormer helps you generate potential solutions to complex problems. Potential applications include discovering new products, targeting markets, and exploring organizational problems. Brainstormer works by building a description of a problem in terms of themes and variations that affect its solution. You refine the process by controlling the occurrence of particular themes and variations until a sufficient amount of potential strategies are produced.

Matchpoint for MS-DOS and CP/M-86

American CompuSoft is marketing a program that lets MS-DOS users run CP/M-86 software. Matchpoint/86 features a File Commingle mode that lets you call for information stored in CP/M-86 format and use it while operating MS-DOS, and vice versa, which makes it possible to run two operating systems simultaneously. When your program is finished, your computer automatically returns to MS-DOS.

What's New?

Brainstormer requires MBASIC, two single-density single-sided 5¼-inch disk drives, and 48K bytes of memory. It's available for the Radio Shack TRS-80 Model I/III and IV and CP/M computers with 80-column screens, such as

the Apple II, Osborne I, and Kaypro II. Available for \$50 directly from Soft Path Systems, Cheshire House, 105 North Adams, Eugene, OR 97402, (503) 342-3439.

Circle 711 on inquiry card.

CHIPS

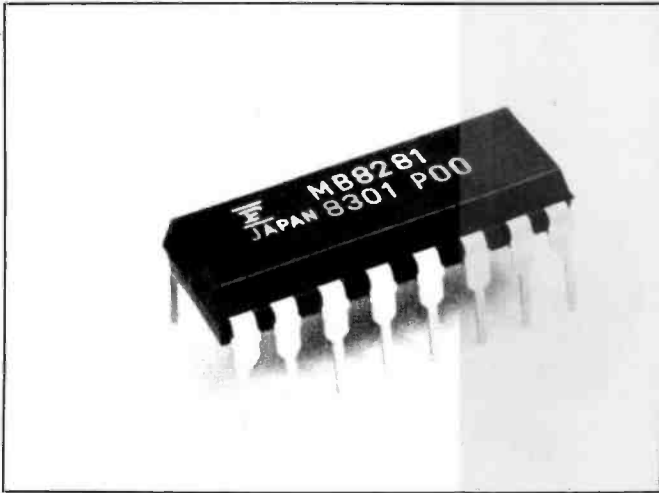

CMOS ROM and Static Column RAM

Fujitsu Microelectronics' MB83256 is a 256K-bit CMOS static ROM organized as 32,768 eight-bit words. It offers twice the memory capacity of a 128K-bit ROM in a JEDEC-compatible 28-pin DIP. Key specifications include 250-ns access time, active power dissipation to less than 83 mW, TTL compatibility, single 5-volt supply, and fully static operation. The MB83256 is designed for large memory capacity and high-speed, low-power environments, such as character generation and large volume firmware storage.

Also available from Fujitsu is the MB8281 Static

Column Dynamic RAM. Offering low power consumption and high-density capabilities, this DRAM features a 64K-by-1-bit organization, a column-address access time of 55 ns, a 60-ns cycle time, a chip-select access time of 20 ns, and 120-ns row-access strobe time. Power consumption is 28 mW (standby) and 440 mW (static mode).

For full details, contact your local Fujitsu Microelectronics sales office. Fujitsu Microelectronics, 3320 Scott Blvd., Santa Clara, CA 95070, (800) 553-2000; in California, (408) 866-5600. Circle 712 on inquiry card.

16-Bit CMOS Microprocessor

Harris Semiconductor CMOS Digital Products Division has announced a high-performance 16-bit CMOS microprocessor, the 80C86. The 80C86 is said to be a completely compatible CMOS alternative to the Intel HMOS 8086. Featuring a static design that allows it to be operated from DC to 5 MHz, the 80C86 permits single-step debugging, a standby power supply current of 500 microamperes over the full operating temperature and voltage ranges, and an operating current of 10 mA/MHz. For maximum power reduction, the 80C86's system clock can be stopped with all power requirements falling to the standby level, 500 μ A. The 80C86 comes in industry-standard 40-pin 0.6-inch center ceramic and plastic DIP packages for commercial, industrial, and military markets. It's available with a 5-MHz operating frequency. An 8-MHz version will be offered.

A complete family of support peripherals is available for the 80C86, including a programmable interval timer and a priority interrupt controller. In 100-unit lots, pricing begins at \$31.25 each for the plastic package. Contact Harris Corp., Semiconductor Sector, POB 883, Melbourne, FL 32901.

Circle 713 on inquiry card.

MOS ROM Features Page Mode Function

Signetics Corporation has introduced a 64K-byte

MOS ROM that doubles the effective memory capacity in video game cartridges. The 26S64's page mode incorporates an address-decoding technique that permits automatic selection of two 4K-byte memory banks, which is billed as being twice the firmware capacity of industry-standard 32K-byte ROMs. Its bank-select addresses trigger a latch that functionally serves as the thirteenth address bit for the 8K-byte memory. (The bank-select address locations must be programmed as no-ops.) Other features include high noise immunity, 550 mW power dissipation (maximum), and a 450-ns access time.

The 26S64 is made with N-channel silicon gate MOS technology using 3-micron design rules. It is TTL-compatible and requires a single +5-volt power supply. It comes in a 24-pin plastic DIP rated for 0° to 70° temperature range operation. In commercial quantities, it costs \$3.85. Contact the MOS ROM Product Marketing Manager, Signetics Corp., Mail Bin 1437, 811 East Arques Ave., POB 3409, Sunnyvale, CA 94088, (408) 746-1755.

Circle 714 on inquiry card.

DUARTs Have Independent Channels

Motorola is marketing a pair of Dual Universal Asynchronous Receivers/Transmitters (DUARTs), the MC68681 and the 2681. These devices provide two

What's New?

independent full-duplex asynchronous receiver/transmitter channels, quadruple-buffered receivers, and multipurpose I/O ports. They can be used in polled or interrupt-driven systems, and each device provides flow-control capabilities to disable a remote transmitter when the receiving unit's buffer is full. Each receiver/transmitter can have independent operating speeds, selected from one of 18 fixed data rates ranging from 50 to 38,400 bps, derived from an internal data-rate generator, a 16X clock derived from a 16-bit programmable multi-function counter/timer, or an external 1X or 16X clock. Data transfers can take place at up to 1 million bps for a 1X clock or up to 125,000 bps for a 16X clock. Other features include local and remote loopback modes and an automatic wake-up mode that permits blocks of data to be sent to targeted slave processors among a group of slaves in multidrop or multiprocessor systems.

The MC68681 works with Motorola's M68000 family, while the 2681 interfaces with non-M68000 family microprocessors. Both have 8-bit output ports; however, the MC68681 has a 6-bit input port and the 2681 offers a 7-bit port.

In quantities of 100, these DUARTs cost \$20.45 in 40-pin ceramic packages. Plastic packaging is also offered. A 28-pin version of the 2681 with a 1-bit input port and a 2-bit output port, called the 2682, is also available. For

further information, contact Motorola Inc., MOS Microprocessor Division, 3501 Ed Bluestein Blvd., Austin, TX 78721. Circle 715 on inquiry card.

Cache and Memory Management Standard on Z80,000

Zilog's 32-bit Z80,000 offers an on-chip cache, memory management, and the ability to execute up to 5 million instructions per second. Designed for clock speeds ranging from 10 to 25 MHz, this chip features full 32-bit architecture and implementation, a complete 32-bit instruction set, 32-bit internal and external data paths, and full support for 32-bit data types.

Fully compatible with the Z8000 family, the Z80,000 comes with 4 gigabytes of directly addressable memory and three selectable address modes: 32-bit linear, 32-bit segmented, and 16-bit compact. Data types supported include bit, bit field, logical value, signed integer, and string. In the compact mode, addresses are 16 bits. All addresses in the linear mode are 32 bits, while in the segmented mode the addresses are divided into either a 15-bit segment within a 16-bit segment offset or a 7-bit segment with a 24-bit segment offset. Other specifications include sixteen 32-bit general-purpose registers, two arithmetic and logic units, privileged instruction traps and

memory-protection-violation traps, two main operating modes supported by separate stacks, and vectored, nonvectored, and nonmaskable interrupts.

The Z80,000, an NMOS chip with 2-micron geometries, is housed in a

68-pin JEDEC B leaderless package. In 1000-unit lots, it costs \$150. Complete specifications are available from Zilog, 1315 Campbell Ave., Campbell, CA 95008, (408) 370-8000. Circle 716 on inquiry card.

FOREIGN

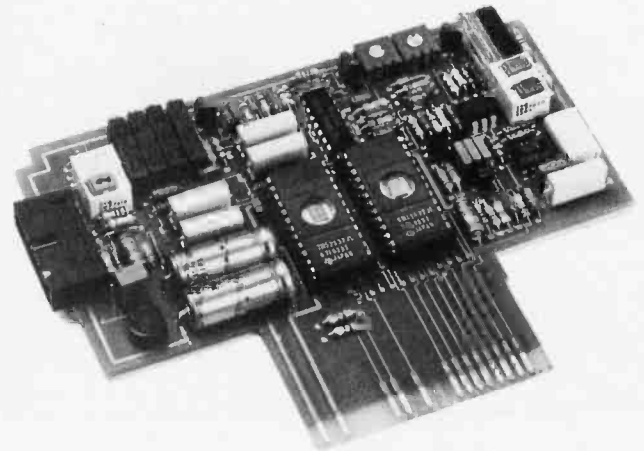

Interface Puts Commodore on Air

The Com-In 64 interface turns your Commodore 64 into a radio-communications terminal. Available from Computer World Holland, this interface gives the Commodore baudot, Morse code, ASCII, slow-scan television, half-duplex, program transmit, and word-processing capabilities. Com-In 64 comes with a ROM-based machine-language program that recognizes more than 60 commands, provides a full-screen editor, and supports hard-copy printout and disk or cassette saves.

Com-In 64 features ASCII program receive and transmit, a built-in AFSK (audio-

frequency shift keying) generator, seven 80-character message buffers with display, print, and write options, a tone generator, an auto transmit/receive switch for telephone/telegraph lines, and four CW (continuous wave) identification lines. The modem is a 300-bps half-duplex with automatic Bell/CCITT selection.

The Com-In 64 costs \$179, including ROM-based software, required hardware, power supply, an English-language user manual, schematic diagram, and two program listings. Contact Computer World Holland, Hilvert-

What's New?

sweg 99, 1214 JB Hiversum, Holland; tel: 31-3512633; Telex: 43776 INCO NL.

Circle 717 on inquiry card.

Software for School Administrators

Vertical Software Systems markets a series of applications packages designed for school board/district administrators. *ST/VS* is a transportation-management program featuring bus-load simulation and student-data and fleet-data maintenance. *MC/VS* is a media-center management program that includes provisions for media catalog generation and material-lending and booking control. *AC/VS*, a fixed-asset management and control system, is also available.

These programs are produced with the C language and are executable under CP/M 2.2, CP/M-86, and MS-DOS. For full details, contact Vertical Software Systems Ltd., 118 Song Meadoway, Willowdale, Ontario, M2H 2T7, Canada, (416) 497-6854.

Circle 718 on inquiry card.

Interactive Query Language Runs on CP/M

The Automated Office has announced the fourth generation of Microtrieve, a high-level interactive query language for CP/M computers, modeled on DEC's Datatrieve. Microtrieve lets inexperienced computer operators extract, sort, and report data

from fixed-record-length files created by most application packages or from a text editor. This language accepts English-like commands. For complete information, address inquiries to

The Automated Office Pty. Ltd., POB 490, Chatswood, New South Wales 2067, Australia; tel: (02) 411 1892.

Circle 719 on inquiry card.

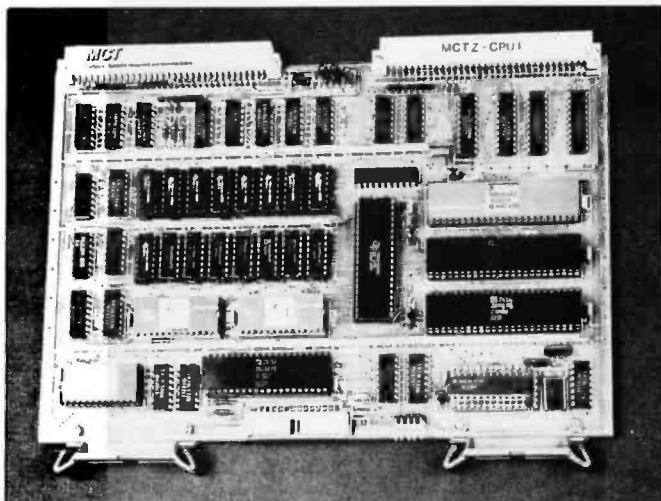

Z8001-based Microcomputer

The MCTZ CPU1 is the first in a series of single-board computers from MMG Consultants Ltd. The CPU1 is targeted at OEMs and systems builders who require a compact computer capable of expansion by means of a 16-bit bus. The CPU1 is based on the double-Europa format and the 4-MHz Z8001 microprocessor. It features a Z8010 MMU, a Z8016 dual-channel DMA controller, a Z8030 synchronous/asynchronous dual-channel serial controller, and the AM9511A chip for floating-point and trigonometric functions. Standard equipment includes 128K bytes of RAM, sockets for 16K bytes of EPROM, facilities for single-step and stop, DIN 41612 type B indirect connectors, and

operational software. The CPU1 costs £2050. For complete specifications, contact MMG Consultants, 19, St. Andrews Rd., Great Malvern, Worcester, WR14 3PR, England; tel: Malvern (06845) 63555.

Circle 720 on inquiry card.

Apple Boards

U-Microcomputers recently introduced four Applebus cards: U-Print16, U-Talk, U-4Disc, and U-Cent. The U-Print16 provides parallel or serial interfacing for connecting printers. It has a 16K-byte buffer and can print graphics directly to Epson and Apple dot-matrix printers. The U-Talk speech synthesizer uses the National Semiconductor

Digitalker. A disk controller, the U-4Disc allows up to four drives to be connected to the Apple. U-Cent is a Centronics-type parallel printer interface. For further information, contact U-Microcomputers Ltd., Winstanley Industrial Estate, Long Lane, Warrington, Cheshire WA2 8PR, England; tel: 0925 54117; Telex: 629279 U-MICRO G.

Circle 721 on inquiry card.

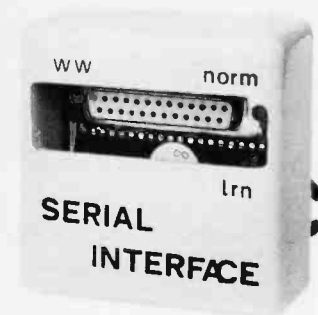

Serial Interface Connects Parallel Printers

The Model 8200 serial interface from Mikrocomputertechnik lets you connect most Centronics-type parallel printers to computers with RS-232C output. In its learning mode, the Model 8200 automatically detects a serial computer's data rates, number of data and stop bits, and parity and adapts itself to the various pin-outs. After installation, which can be repeated whenever parameters change, all parameters are permanently stored in EEROM. Up to 15 code changes can be selected in a simple dialogue. The following parameters are automatically detected

What's New?

by this interface: 7 or 8 data bits; even, odd, or no parity; 1, 1.5, and 2 stop bits; and 150, 300, 600, 1200, 2400, 4800, and 9600 bps.

The Model 8200 serial interface costs \$125;

volume discounts are available. Dealer inquiries are invited. Contact Mikrocomputertechnik, Winchenbachstr. 3A, D-5600 Wuppertal 2, West Germany; tel: 0202 51044.

Circle 722 on inquiry card.

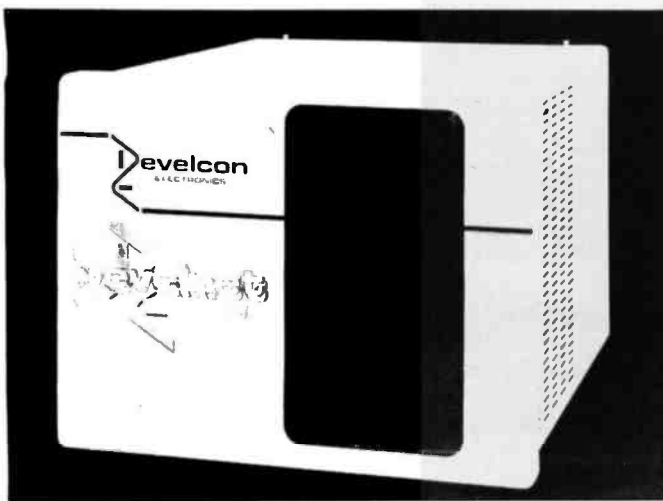

Network Switching Node

Develnet is a network of switching nodes providing local-network and distributed switching capabilities. Each node supports up to 248 data lines with a throughput of 24 million bps. Up to 64 Develnets can be interconnected in a hierarchical network. Asynchronous and synchronous speeds to 19,200 bps are supported by means of twisted-pair wire or local RS-232C cables to the nodes. Other features include intelligent line cards and data sets, redundant backup hardware, integral statistical multiplexers, protocol converters, gateways to Ethernet and X.25 networks, and an English-like command language for network configuration. Further details are available

from Develcon Electronics Ltd., 856 51st St. E, Saskatoon, Saskatchewan S7K 5C7, Canada, (306) 664-3777.

Circle 723 on inquiry card.

SYSTEMS

Briefcase-size Workslate

Convergent Technologies' Workslate combines portable computing power, information storage, and business programs in a package small enough to fit into a briefcase. Built around an 8-bit CMOS microprocessor, the Workslate comes with 64K bytes of ROM, 16K bytes of RAM, an integral microcassette recorder, a 46-character by 16-line LCD display,

an internal 300-bps modem with auto-dial and auto-answer, and a 9600-bps serial interface port. It's powered by four AA alkaline cells or an AC recharger. Standard features include an internal clock, edit functions, and a calculator.

A business worksheet with integrated date, time, and communications functions and a variety of microcassette tapes for general business, vertical market, and personal applications are offered. A serial printer featuring multicolors, 90-degree printing, and formed characters is available as well. The Workslate costs \$895. The printer is \$250, and software prices range from \$19.95 to \$49.95. Volume shipments begin in January. For more information, contact Convergent Technologies, 795 Kifer Rd., Sunnyvale, CA 94086, (408) 732-2310.

Circle 724 on inquiry card.

Honeywell 6/20 Supports Four Users

Honeywell's Microsystem 6/20 supports up to four users, targeting it directly at the departmental office system and small-business market. The basic 6/20 contains a 16-bit Honeywell Micro 6 processor, up to 1 megabyte of main memory, 650K bytes of 5¼-inch floppy-disk storage, a 40-megabyte hard-disk featuring 20 megabytes of removable media, an open slot, and five RS-422A ports that are adaptable to RS-232C devices.

The GCOS 6 MOD 400 operating system, used in Honeywell 16- and 32-bit DPS 6 computers, is standard. GCOS 6 MOD 400 is menu-driven and supports transaction processing, data entry, office automation, terminal emulation, program development, and communications software.

The 6/20's communications features let it serve as an endpoint for several workstations in larger Honeywell or IBM information-processing networks, such as those using DSA and SNA protocols. In addition to these abilities, the 6/20 can provide electronic mail, BSC and pre-DSA communications, and teletype emulation.

A number of office-automation and data-entry packages to integrate system and applications software with the 6/20 are available. Other options include three dot-matrix and two letter-quality printers, a dual-line asynchronous/synchronous communications controller, and a second 40-megabyte disk. The basic 6/20 costs \$17,000. Workstations configurable for the system start at \$795. The printers begin at \$1195. For more information, contact Honeywell Inc., U.S. Marketing and Services Group, 200 Smith St., Waltham, MA 02154, (617) 895-3658.

Circle 725 on inquiry card.

BBC Computer Available In U.S.

The Acorn BBC computer is now available in

What's New?

the United States through Fourth Dimension. This 2-MHz 6502-based micro-computer comes with 32K bytes of RAM, 32K bytes of ROM, a 73-key QWERTY keyboard with 10 user-definable function keys, a three-voice music synthesizer with full sound envelope, and a speech-generation system. Rear-panel connections are provided for UHF out, video out, RGB monitor, audiocassette, and a local-area network. The built-in RS-423A serial interface, an RS-232C interface enhanced for speed and distance, has software-selectable data rates ranging from 75 to 19,200 bps. A floppy-disk interface and four 12-bit analog input channels are standard.

NTSC television output, RGB video output for color monitors, and monochrome monitors compose the video-display options. Among the display modes available are 40 by 22 Teletext, 160 by 200 four- or 16-color graphics and 20 by 25 text, and 640 by 200 two-color graphics and 80 by 25 text.

A 16K-byte BASIC interpreter in ROM comes with the BBC. This interpreter has a 6502 assembler that permits BASIC statements to be mixed with 6502 assembly language and such extensions as local variables, subroutines that pass parameters, and recursion. Also in ROM is View, a 16K-byte word processor. View provides global and selective formatting; search, change, and replace facilities; adjustable tab stops; and automatic

page numbering.

Optional expansion capabilities include a second 6502 or Z80B processor with 64K bytes of RAM and a National Semiconductor 16032 chip. The Acorn BBC computer begins at \$995. Dealer inquiries are invited. For further details, contact Fourth Dimension Systems, 1101 South Grand Ave., Santa Ana, CA 92705, (714) 835-6202.

Circle 726 on inquiry card.



Group Computer Handles Information Needs

Sykes Datatronics' Genus-GC Group Computer and its complementary software are targeted at the information-handling needs of managers, group or team leaders, and the people they manage. This multiuser, multitasking desktop computer performs traditional data-processing functions, connects to a variety of terminal devices, and allows data from a number of sources to be gathered and interfaced with existing data streams and formats. All data, which is fully secured, can be reformatted to meet individual requirements by means of an optional software "forms" package.

This software permits user definition and implementation of a complete information system that includes input, file management, and output processing. Sykes has also developed software that provides basic call-costing accounting functions for up to 2000 lines. Called Tele-miser, this program can store more than 50,000 call records.

Some of Genus-GC's technical specifications are 68B09E processing power, 256K bytes of DRAM with parity error correction, real-time clock, PABX-oriented networking abilities, and twin RS-232C ports. Mass storage is provided by a 1-megabyte 8-inch double-sided, double-density floppy-disk drive and a 10- or 15-megabyte 5¼-inch Winchester disk drive. Enhanced with shell procedural capabilities and hierarchical directory structure, the OS9 Unix-like operating system is standard.

An internal modem, two additional RS-232C ports, and terminals, printers, and remote data-communications are among the options offered. Prices for the Genus-GC begin at \$9455. Further details are available from Sykes Datatronics Inc., 159 East Main St., Rochester, NY 14604, (716) 325-9000.

Circle 727 on inquiry card.

Large Memory Accompanies Rebel

The Rebel computer from Tarbell Electronics comes with 372K bytes of

floppy-disk storage and 19 megabytes of hard-disk memory. The Rebel features 64K bytes of RAM, two RS-232C ports, and a 6-MHz Z80B microprocessor. The Tarbell database system, BASIC, Wordstar, and CP/M 2.2 are supplied with the Rebel.

The Rebel costs \$4995, including a cabinet that houses all hardware and the power supply. Complete details are available from Tarbell Electronics, Suite B, 950 Dovlen Pl., Carson City, CA 90746, (213) 538-4251.

Circle 728 on inquiry card.



Micro Processes Data and Words, Has Communications Features

The Stearns Computer is purported to be the first stand-alone desktop computer specifically designed to perform high-quality data and word processing while providing full internal and external communications and networking capabilities. This 16-bit 8086-based system can be configured with as many as four 5¼-inch floppy-disk drives and two 5-, 10-, or 20-megabyte Winchester hard-disk drives. It comes with 128K bytes of parity RAM, time and date clock with battery backup, 16K

What's New?

bytes of ROM for initialization and self-tests, up to a dozen DMA channels, and four slots for expansion boards. The standard operating system is MS-DOS. The 12-inch display uses a 7220 graphics display controller and provides 26 lines of 80 characters and the 256-character IBM font with an additional user-defined font. Attributes include reverse video, blink, bold, and underline.

Communications capabilities include an RS-232C port operating at speeds ranging from 75 to 19,200 bps, built-in tutorial prompts, disk-file transfer with error recovery, automatic dial-up for host access, user-defined data translation, Teletex, IBM 3270 bisynchronous and IBM 3270 SNA/SDLC protocols, and from two to four asynchronous or synchronous RS-422A channels with operation to

56,000 bps. Optional networking abilities are available through Micronet, which allows up to five intelligent workstations to be linked together. Each workstation is able to use applications software, files, and databases while sharing printers, a common database, and communications with external sources. Stearns is working on an intelligent communication system that will work with Micronet to handle up to 32 workstations.

Color graphics, 15-inch display screens, 128K or 256K bytes of memory, Concurrent CP/M, and a two-channel Winchester-disk controller are some of the options offered. For full details, contact Stearns Computer Systems, 3501 Raleigh Ave. S, Minneapolis, MN 55416, (612) 929-4400.

Circle 729 on inquiry card.

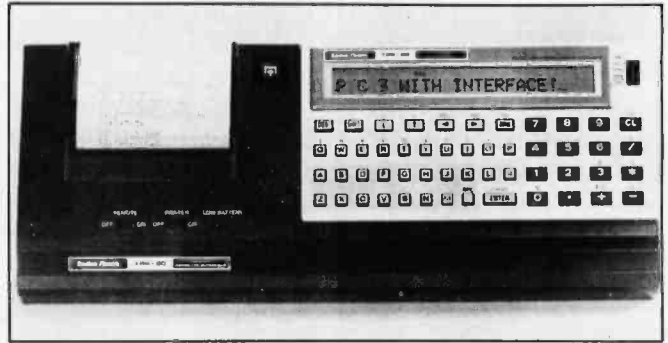

Shirt-pocket Computer

Radio Shack's four-ounce TRS-80 PC-3 pocket computer will slip into your shirt pocket. The PC-3, programmable in BASIC, provides 16 arithmetic and 8 string functions. Strings can be up to seven characters long. The PC-3, which can be used as if it were a direct key-entry calculator, has a 24-character LCD, up to 10 digits of accuracy, 1.4K bytes of memory, two-digit exponents, and multiple statements and arrays. Other features include automatic power-off to

save battery life and compatibility with PC-1 programs.

A printer/cassette interface is available as an option. The thermal dot-matrix printer produces 24 characters per line at 1 line per second. The printer/cassette interface costs \$119.95. The PC-3 is available for \$99.95 at Radio Shack stores and Computer Centers. Radio Shack, 1800 Tandy Center, Fort Worth, TX 76102.

Circle 731 on inquiry card.

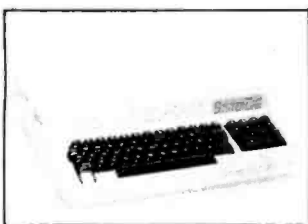

CP/M and AppleDOS Combined In One System

The System One from Extra Computer Corporation is a Z80/6502-based computer supporting CP/M 2.2 and AppleDOS. Principal features include 64K bytes of RAM, 8K bytes of system ROM, 16K bytes of user ROM, and seven peripheral slots. Low- and

high-resolution graphics, 40- and 80-column display modes, and NTSC and RF modulated video outputs are built in. The keyboard, a standard typewriter-style model, is augmented by an extra numeric keypad for repetitive number entry. System software is made up of Applesoft, Perfect Writer, Perfect Calc, and a games package.

The suggested retail price is \$795. For full specifications, contact Extra Computer Corp., 68 Dorman St., San Francisco, CA 94124, (415) 285-0194.

Circle 730 on inquiry card.

MASS STORAGE

18-megabyte Streaming Tape Backup

Davong's stand-alone streaming tape drive backs up any Winchester- or floppy-disk drive used with the IBM Personal Computer. The Davong unit copies 18 megabytes of formatted data onto a single 450-foot ¼-inch tape cartridge. It's supplied with software utilities for initial checkout, copy from disk to tape, and restoring files from tape to disk. The utilities also compare files so that the most current file with the same name is restored, preventing retrieval of obsolete

files. Files can be restored to a different volume, and an index lists names and dates of all backup files. Linear speed is 90 inches per second, and the bit density is 8000 bits per inch. The average transfer rate is 28.9K bytes per second. Its error-checking modes are Check Sum, Read after Write, and Group Coded Recording. Verify Pass error checking is optional.

The Davong streaming tape backup costs \$2195, including cabling, adapters,

What's New?

software, and documentation. For additional information, contact Davong Systems, 217 Humboldt

Court, Sunnyvale, CA 94089, (408) 734-4900. Circle 732 on inquiry card.

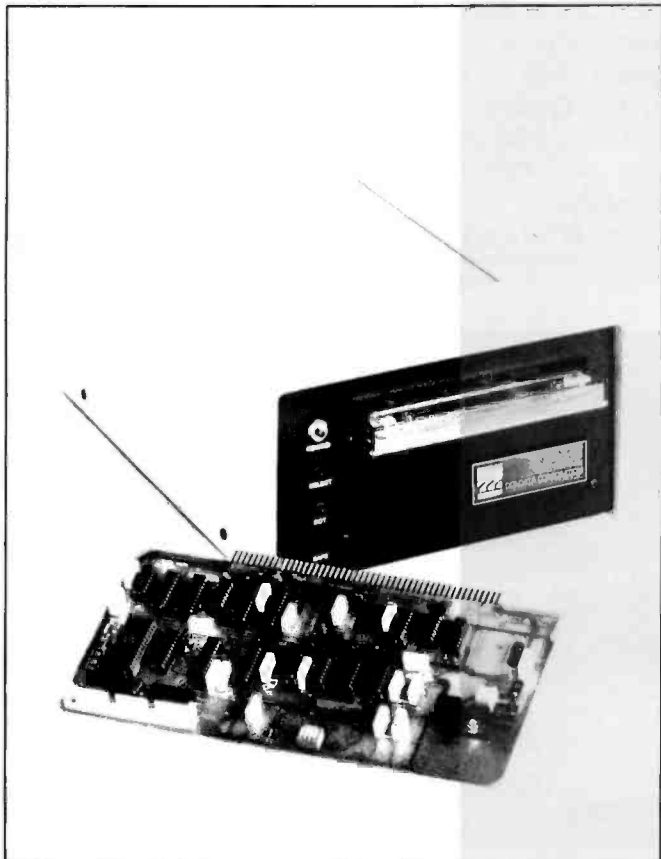

Drive Subsystem for S-100 Bus

Digi-Data's Model 70S cartridge tape drive works with any 8080-, 8085-, or Z80-based S-100 bus computer. This device stores up to 17.3 megabytes of unformatted data. The transfer rate is 20K bytes per second. Record lengths are selectable from 256 to 32K bytes for a total formatted storage capacity of 16.6 megabytes. The maximum effective storage rate is 1.1 megabytes per minute. Up to eight units can be supported by a single S-100 controller board. The Model 70S operates as a nonin-

telligent I/O memory to the host.

Utility programs on 5¼- or 8-inch disks are provided. For complete particulars, contact Digi-Data Corp., 8580 Dorsey Run Rd., Jessup, MD 20794, (301) 498-0200.

Circle 733 on inquiry card.

Hard-Disk Subsystem for Z-100

Thought Works has announced the availability of Datafiles, a line of hard-disk subsystems for the Zenith

Z-100 computer. Three storage capacities are offered: 5, 10, and 20 megabytes. Datafiles are self-contained systems, complete with intelligent controller, power supply, cabinet, and software. Hard wiring is not required because interconnection is accomplished by means of an interface board installed in a Z-100 slot and a ribbon cable. The software supports both CP/M and Z-DOS. Prices range from \$2495 to \$3995. For full specifications, contact Thoughtworks, 3532 West Thomas Rd., Phoenix, AZ 85019, (602) 269-6841. Circle 734 on inquiry card.

Minifile Available with Two Capacities

The FDS-100 Minifile, a self-contained, intelligent 5¼-inch floppy-disk subsystem, is available in single-sided 89K-byte and double-sided 179K-byte versions. The basic Minifile features a microprocessor controller, power supply, and an RS-232C interface. Minifile's file-management functions are resident in firmware and controlled from a front-panel keyboard. System status and error information is communicated to the operator by means of a three-digit, seven-segment numeric display. A variety of switch-selectable options for data rates, number of stop bits, and hardware synchronization are provided.

Versions of the Minifile with an 8-bit parallel interface and dual RS-232C

ports are available. The parallel interface model offers handshaking signals. The Minifile ranges from \$1595 to \$2295, depending on storage capacities. For more information, contact Atek NC Corp., 887 Main St., POB E, Monroe, CT 06468, (203) 268-1839. Circle 735 on inquiry card.

Winchester Backup System

Mountain Computers' 10-megabyte cassette-tape drive backs up 5¼-inch Winchester hard-disk drives. This single-head four-track drive is for use with Apple and IBM Personal Computers and can record or transfer data at either 30 or 90 ips (inches per second). Average backup times are 12 minutes at 30 ips and 4 minutes at 90 ips. The transfer rate is 24K bytes per second at 30 ips and 72K bytes per second at 90 ips. ANSI-standard 450-foot cassette tapes are used.

The tape drive costs \$1095. The controller interface is \$295. Mountain Computer Inc., 300 El Pueblo Rd., Scotts Valley, CA 95066, (408) 438-6650. Circle 736 on inquiry card.

3½-Inch Winchesters on Market

Two versions of the Rodime PLC line of 3½-inch Winchester disk drives are available: the Model RO 351, a single-platter drive with 5 mega-

What's New?

bytes of formatted storage, and the RO 352, which has twin platters for twice the storage. The 350 series drives use open-loop head/arm positioning with a double-precision stepper motor. Data records at 600 tpi with more than 11,000 bits per inch. The average access time is 85 milliseconds; track-to-track access time is 15 milliseconds. The data-transfer rate is 5 megabits per second. Physical dimensions are 1.625 by 4 by 5.25 inches—about one-quarter the volume of a standard 5¼-inch Winchester drive.

In OEM quantities, the Model RO 351 costs \$555 and the RO 352 is \$695. For more information, contact Rodime PLC, 25801 Obrero, Mission Viejo, CA 91291, (714) 770-3085. Circle 737 on inquiry card.

PRINTERS

Olympian Letter-quality Printers

Olympia USA has introduced two letter-quality printers: the ESW3000 and the Electronic Compact RO. Both printers are microprocessor-controlled with bidirectional paper and carriage movement.

The 50-cps ESW3000 can handle forms up to 17 inches wide and has the ability to print 150, 180, and 255 characters per line in 10, 12, and 15 pitch, respectively. Print enhancements include boldface, expanded print, and double print. The ESW3000 uses a 100-character print wheel. It is available with a serial RS-232C, a Centronics-

compatible parallel, or an IEEE-488 interface. A bidirectional forms tractor and sheet feeder are optional. It costs \$1899.

The Electronic Compact RO has built-in serial and parallel interfaces that offer compatibility with a variety of computers. This printer operates at 14 cps and offers boldface and underline printing. Original plus four copies can be printed

simultaneously, and it handles forms up to 14½ inches wide. The Compact RO prints 115 characters per line in 10 pitch, 138 in 12 pitch, and 172 in 15 pitch. It's outfitted with a forms tractor. The suggested price is less than \$700. Contact Olympia USA Inc., POB 22, Somerville, NJ 08876, (201) 722-7000.

Circle 738 on inquiry card.

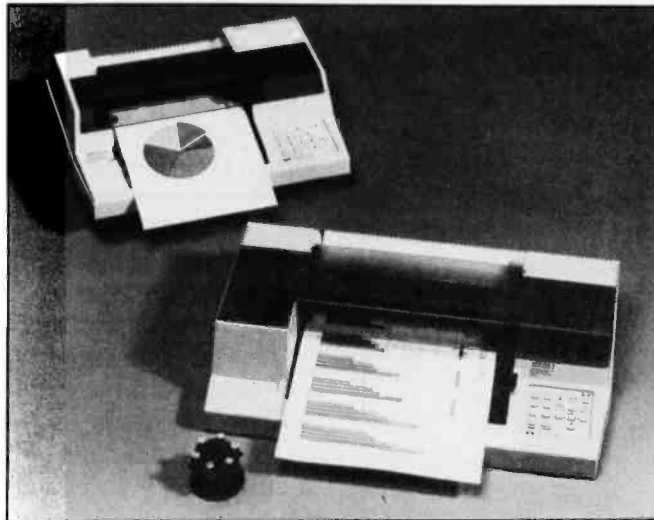

Color Plots in Less Than Three Minutes

Hewlett-Packard's HP 7475A can plot as fast as 15 inches per second to create a variety of multi-color pie, bar, line, and text charts in less than three minutes. This desktop-sized plotter has a 2g pen acceleration and uses a six-pen, drop-in carousel to produce a line resolution of 0.001 inches. Pens are selected from the carousel by either front-panel controls or through program commands. When returned to the carousel, the pens are automatically capped to prevent dry-out. Standard features include a pen-velo-

city command for special drawing conditions, a "view" mode that halts the plotting so that you can review the chart being produced, and the ability to rotate charts 90°, which simplifies adding horizontal charts into vertical formats. The HP 7475A accepts 11-by 17-inch paper and 8½-by 11-inch paper and overhead transparency film. Its dimensions are 22½ by 14½ by 5 inches.

The HP 7475A is compatible with a broad range of computers and software from such manufacturers as Apple, Lotus, and IBM.

Two interfaces are available: RS-232C and HP-IB, a Hewlett-Packard-enhanced version of the IEEE-488 bus. An optional cable lets you operate the plotter in series with a terminal when using the RS-232C interface. The list price for the HP 7475A is \$1895. For full details, contact your local Hewlett-Packard sales office. Circle 739 on inquiry card.

Multifunction Printer for Text and Graphics

The Facit 4528T intelligent printer prints text, matrix characters, and pin graphics at 165 cps. In its standard mode, this multipass unit produces near-letter-quality characters, unidirectionally or bidirectionally, with selectable standard, boldface, condensed, extended, and hybrid print styles. It offers pitches of 10, 12, or 17, proportional spacing, and the ability to print at 285 cps at 17 cpi. It offers continuous tractor-feed and multipart forms capability for original plus six copies. Paper length is programmable up to 18 inches.

An optional package lets you print variable-size

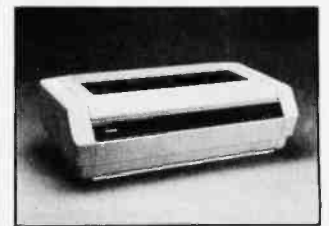

characters and up to nine different bar codes. Characters can be printed in any size, up to 9¾ inches, and can be positioned sideways and upside down on

What's New?

the same line. The 4528T can print formatted labels on paper, plastics, and thin metals, and it can create custom formats for specialized labels. Incrementing and decrementing counters are provided for sequential labeling and message variation. Up to 10,000 repeat-message label copies can be pro-

duced offline.

The Facit 4528T has a hinged cover with either a solid top with rear paper exit or a slotted top. It costs \$1595. The variable-size and bar-code option is \$400. Contact Facit Inc., 235 Main Dunstable Rd., Nashua, NH 03061.

Circle 740 on inquiry card.

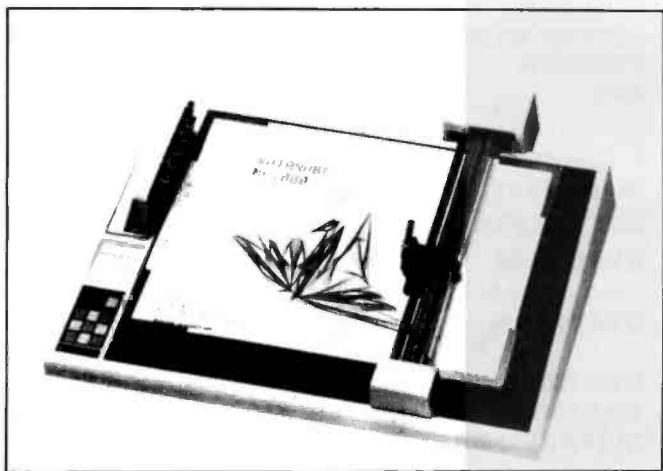

6-Inch-Per-Second Plotter

The MP 1000 plotter from Watanabe Instruments Corporation has a plotting speed of 6 inches per second. It can operate with oil- or water-based fiber-tip pens or ink drafting pens. Six different pens can be automatically selected during the plotting process. A built-in single ASCII-character instruction set, said to be simple to access and use, lets you write programs for the plotter with minimal fuss. The MP 1000 can be equipped with three interfaces: serial RS-232C, GPIB IEEE-488, or 7- or 8-bit parallel.

The IEEE-488 and the parallel models cost \$1190.

The RS-232C version is \$1090. Contact Watanabe Instruments Corp., 12 Chrysler St., Irvine, CA 92714, (714) 770-6010.

Circle 741 on inquiry card.

MISCELLANEOUS

Customize Your Computer Work Area

You can custom design your microcomputer workstation with Misco's line of modular furniture. The line is made up of computer and printer stands, a connecting leaf, a universal compartment, and a printer paper basket, all of which can be used individ-

ually or positioned in various configurations. These products feature a walnut-grain laminated top and black steel legs. Optional casters can be added to the stands. Prices begin

at \$24.95. The complete line costs \$224.75. Contact Misco Inc., 404 Timber Lane, Marlboro, NJ 07746, (800) 631-2227; in New Jersey, (201) 946-3500. Circle 742 on inquiry card.



Pair of Robots for the Home

Bob and Fred are a pair of robots from Androbot. Bob (brains-on-board) is built with an 8086 microprocessor, 3 megabytes of main memory, and 10 slots that house its components and provide for expansion capabilities. Bob can navigate a room and talk in a human-like voice. Infrared sensors attract it to humans, while ultrasonic sensors help Bob avoid inanimate objects. Options include Androwagon, which enables this robot to transport objects from room to room.

Fred (friendly robot educational device) is designed to serve as an introduction to robotics. It serves as a mobile extension of your home computer and can be programmed to perform a series of movements or operated independently by a remote infrared controller. Fred has the ability to execute on paper complex geometric shapes produced on a computer

screen. It's packaged with a mini Androwagon for transporting small objects. Mechanical sensors detect edges, preventing Fred from falling off table tops.

Bob costs \$2995. The optional Androwagon is \$95. Fred costs \$300. For complete information, contact Androbot Inc., 101 East Daggett Dr., San Jose, CA 95134, (408) 262-8676.

Circle 743 on inquiry card.

Where Do New Products Items Come From?

The information printed in the new products pages of BYTE is obtained from "new product" or "press release" copy sent by the promoters of new products. If in our judgment the information might be of interest to the personal computing experimenters and homebrewers who read BYTE, we print it in some form. We openly solicit releases and photos from manufacturers and suppliers to this marketplace. The information is printed more or less as a first-in first-out queue, subject to occasional priority modifications. While we would not knowingly print untrue or inaccurate data, or data from unreliable companies, our capacity to evaluate the products and companies appearing in the "What's New?" feature is necessarily limited. We therefore cannot be responsible for product quality or company performance.

MICROMAIL™



IBM PC-COMplete SYSTEM VERY SPECIAL PRICE

PC System includes 64K IBM PC with two Disk Drives, Controller, Color Graphics Card, Monitor. . . **\$2590**

SPECIAL OF THE MONTH!!

IBM PC W/64K, 360KB Disk Drive, FDC, Color Graphics Card, Monitor, 10MB Hard Disk W/Controller, Cable, Software, Matrix printer, Cable, all for only **\$3990**

DISK DRIVES FOR IBM PC

Tandon 100-2	\$240
Shugart 455-2	\$245
Teac 55-B	\$255

MONITORS

AMDEK 300	\$170	300A	\$190
-----------	-------	------	-------

PRINCETON GRAPHICS SYSTEMS

Hi-Res Color	\$490
--------------	-------

PRINTERS

C-ITOH

GX-100	\$240	1550	\$690
8510	\$460	F-10	\$1290
F-10			\$1690

OKIDATA

82A	\$440	84A	\$975
83A	\$690	92A	\$575
93A			\$970

EPSON

FX-80	CALL	FX-100	CALL
-------	------	--------	------

BROTHER

HR-1	\$750
HR-15	\$570

SMITH CORONA

TP-1	\$520
------	-------

STAR MICRONICS

Gemini 10	\$370
Gemini 15	\$540

DIABLO

	CALL
--	------

NEC SPINWRITER

7710-1	\$1950	3510	\$1350
7715-1	\$2100	3515	\$1350
7720-1	\$2400	3530	\$1550
7725-1	\$2400	3550	\$1850
7730-1	\$1950	PC8023A	\$450

HARD DISKS FOR APPLE AND IBM

DAVONG

5 MB	\$1450
10 MB	\$1650
15 MB	\$2250

MEMORY BOARDS

MONTE CARLO	CALL
TECMAR	CALL

AST

IO Plus. Five function Card	\$199
Combo Plus 4 function card. Fully pop. 256K	\$490
Mega Plus. Fully pop. 512K	\$990

AST SIXPAK 384K	CALL
-----------------	------

QUADRAM

Quad Card. Fully pop. 256K	\$500
----------------------------	-------

QUADLINK	CALL
----------	------

BIG BLUE	\$470
----------	-------

HERCULES Graphics Card	\$490
------------------------	-------

MAYNARD SANDSTAR SERIES

FDC 5 1/4 & 8"	\$220
Multifunction Card	\$90
Memory Card	\$180

DISK DRIVE FOR APPLE

Slimline, or Standard	\$250
-----------------------	-------

PERSONAL ACCOUNTANT Software for your Apple IIe and Apple II+. . . **\$190**

APPLE IIe

Computer System, Controller, Two Disk Drives, Monitor. . . **\$1590**

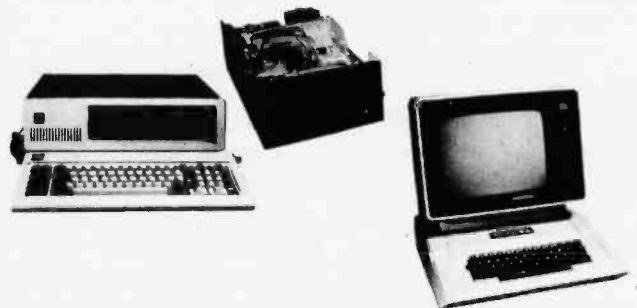

MICROMAIL

631 E. First St., Tustin, CA 92680

PRICES AND AVAILABILITY SUBJECT TO CHANGE WITHOUT NOTICE

(714) 838-9100

APPLE is a trademark of Apple Computers, Inc.
IBM is a trademark of IBM Corp.

CHECK SUNTRONICS NEW LOW PRICES

Apple Compatible Products



AFDC-1 Floppy Disk Drive Controller... **\$79.95**
Runs DOS 3.3 with any standard Shugart compatible 5 1/4" Disk Drive. (2 Drives Each Card)



ASCII KEYBOARD A&T... **\$79.00**
Plug in compatible with Apple II, has shiftlock, underscore, [] and back slash characters.

Apple Prototype Board.



Double Sided glass with gold plated Apple and General Purpose terminals. Contains matrix of 17 x 63 solder plated donuts

on .15" x .1" spacing. Great for 14, 16, and 24 pin IC's.

- SUN-722 7.95
- Apprate PROM Blaster 119.00
- "ALS" 80 Column Card 159.00
- "ALS" Z-CARD (Z80 CPU) 149.00
- API Apple Parallel Printer Interface card. Centronics Compatible. 45.00

General Products

- Mitsubishi Disk Drives, 5 1/4" and 8" Slim
- 5 1/4" Thin DSDD 40 Track 310.00
- 8" Thin DSDD 77 Track 450.00

SUNTRONICS CO., INC.
12621 Crenshaw Blvd., Hawthorne, CA 90250

STORE HOURS: MON-FRI 9:00am to 6:00pm
SATURDAY 10:00am to 5:00pm

General Products- cont.

Video Monitors



- SAMWOO GREEN 9" 18MHz \$115.00
 - SAMWOO AMBER 9" 18MHz 119.00
 - SAMWOO GREEN 12" 12MHz 124.00
 - SAMWOO AMBER 12" 12MHz 127.00
- Composite video I/O. 750 lines resolution. 75/10K ohm impedance. Note: Please add \$7.50 shipping and handling for the video monitors.

Assembled Connectors and Cables

- Centronics Type Cable Assemblies 36 pin flat cable with male to male or male to female connectors. 4 ft.—\$24.95 6 ft.—\$27.95
- RS232 Cable Assemblies 25 pin flat cable with male to male or male to female connectors. 5 ft.—\$29.95 10 ft.—\$35.95

Assemble Your Own Cables

Condl.	Ribbon Cable Price/Ft.	Card Edge Connector Price	IDS Socket Price	Header (w/w) Price
20	\$0.50	\$2.46	\$3.06	\$4.24
26	0.85	4.80	3.87	4.68
34	0.83	5.93	6.30	5.25
40	1.00	6.90	7.20	5.95
50	1.30	7.58	7.50	6.20

- IDS DB-25P Connector \$5.95
- IDS DB-25S Connector \$6.25

Super Sale

P/N	8-24	25up	P/N	8-24	25up
2716 (450nS)	3.80	3.55	6116P-3 (150nS)	6.10	5.75
2732 (450nS)	4.15	3.98	2114L-2 (200nS)	1.62	1.62
2532 (450nS)	5.95	5.95	4164	Call	Call
2764 (28 pin)	5.95	5.95	Z80A CPU	4.99	4.99

CALIFORNIA **213-644-1149**
(for Tech Info and Calif orders)

Mail Order—Minimum Order: \$10. Send Check or Money Order to: P.O. BOX 1957 Dept B, HAWTHORNE, CA 90250 Visa/MasterCard (please include expiration date). Add \$2.00 postage and handling for first 3 pounds plus .50 for each additional pound to your order. California residents add 6% sales tax.

S-100 Products



S-100 MEMORY BOARD

\$155.00
64KSM A&T without RAM
64KSM A&T with 64k RAM (32-6116's) 339.00
S-100 Board Uses 6MHz 6116's. 1/2A max. power. Bank Select plus Extended Addressing allow for multi-memory board set-up. 4 independant 16K Blocks make easy use with multi-user systems. Any 2K RAM may be replaced by 2716 EPROM.

SBC-880 Z80A CPU, A&T \$169.00
SBC-880 Z80A CPU, Kit 149.00

4MHz Z80A CPU boards with Serial-Parallel Ports
UFDC-1 Floppy Controller, A&T 245.00
UFDC-1 Floppy Controller, Kit 225.00
The UFDC-1 Floppy Controller uses the WD1795 chip which runs either and/or 8" 5 1/4" Disk Drives

CLOCK CALENDAR A&T 115.00
CLOCK CALENDAR Kit 95.00

This S-100 Clock Calendar Board has 4 interrupts. Time, Day of Week and Battery Backup

S-100 Prototype Board

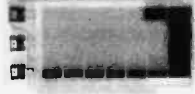

Double Sided glass with gold plated, numbered S-100 terminals. Matrix of 25 x 78 solder plated donuts on .15" x .1" spacing. Locations for headers and regulators. Great for 14, 16, and 24 pin IC's.

SUN-721 12.95

Mother Boards & Card Cages

SLOTS	Bare Bd	KIT	A & T	w/CAGE
6	\$12.00	\$37.00	\$52.00	\$77.00
8	16.00	48.00	73.00	108.00
12	22.00	68.00	103.00	143.00

10MHz. No termination. Includes power indicator and wiring for muffin fan. Uses OKI connector for solderless installation and removal of power & reset lines.

OUTSIDE CALIFORNIA TOLL FREE **1-800-421-5775**
(Order Desk Only)

SUNNY LOW LOW COST POWER SUPPLIES (LINEAR & SWITCHING) FOR S-100, DISK DRIVES

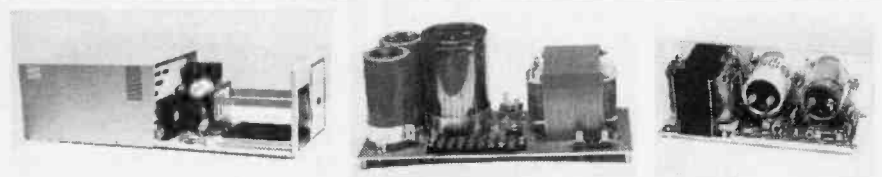

S-100 & DISK POWER SUPPLIES:

ITEM	IDEAL FOR	+5V OVP	-5V	+24V(OR +12V)	+8V	+16V	SIZE W x D x H	PRICE
S ₃	12 SLOT & 2 FLOPPY (1 Floppy & 1 Hard Disk)	5A	1A	5-7A PEAK	13A	3A	10" x 6" x 5"	105.95
S ₄	6 SLOT & 2 FLOPPY	4A	1A	4-5A PEAK	8A	3A	8 3/8" x 5" x 4 3/4"	95.95

DISK POWER SUPPLIES:

ITEM	IDEAL FOR	+5V OVP	5V	+24V (or +12V)	+8V Unreg.	+12V	SIZE W x D x H	PRICE
R ₀	2 x 8" SLIMLINE	2.5A	1A	2.5A - 5A Peak			5" x 4" x 4"	51.95
R ₁	2 x 8" or 2 x 5 1/4" DISK	4A	1A	3A - 5A Peak	2A		8" x 4" x 3 3/4"	56.95
R ₂	3 x 8" (or 5 1/4") FLOPPY	6A	1A	6A - 8A Peak			10" x 4 7/8" x 3 3/4"	71.95
R ₃	or 1x Floppy & 1x Hard	6A	1A	6A - 8A Peak		1A	9" x 6 1/2" x 4 3/8"	85.95

AC & DC POWER CABLES WITH CONNECTOR FOR 2 DRIVES 8.00

S-100 POWER SUPPLY KITS (OPEN FRAME WITH BASE PLATE, 3 HRS. ASSY. TIME)

ITEM	(IDEAL FOR)	+8V	-8V	+16V	-16V	+28V	SIZE: WxDxH	PRICE
KIT 1	15 CARDS	15A	---	2.5A	2.5A	---	12" x 5" x 4 7/8"	54.95
KIT 2	20 CARDS	25A	---	3A	3A	---	12" x 5" x 4 7/8"	61.95
KIT 3	DISK SYSTEM	15A	1A	3A	3A	5A	13 1/2" x 5" x 4 7/8"	69.95

6 SLOT MAINFRAME ASSY. & TESTED ONLY \$399.95 + SHIPPING \$18.00

EACH MAINFRAME (ITEM NO. 806 OR 516) CONTAINS: EMI FILTER • FUSE HOLDER • AC POWER CORD • POWER SWITCH & INDICATOR • RESET SWITCH • 4" COOLING FAN • S-100 BUS 6 SLOT CARD CAGE • (110/220 VAC, 50/60 HZ.) POWER SUPPLY FOR DISK DRIVES & S-100 SLOTS • 2 EA. DC POWER CABLES WITH CONNECTOR AND MOUNTING HARDWARE FOR DISK DRIVES • 9 EA. CUT-OUTS; 7 FOR DB25 CONNECTOR, 1 FOR 50 PIN CONNECTOR & 1 FOR CENTRONICS • CUSTOM FINISH & LOGO-LESS • COMPACT SIZE • LIGHTWEIGHT, 28 LBS.
ITEM #806 FOR 2 EA. 8" THINLINE FLOPPY (TANDON TM848-1 & 848-2 OR EQUIV.), OR ONE HARD DISK, POWER SUPPLY: +8V/8A, ±16V/3A, +5V/5A OVP, 5V/1A & 24V/5A. SIZE: 12"(W) x 19.5"(D) x 9.8"(H).
ITEM #516 FOR 2 EA. 5 1/4" FLOPPY (TANDON TM-100 - 1, 2, 3, 4 OR EQUIV.), OR ONE 5 1/4" FLOPPY & ONE 5 1/4" WINCHESTER HARD DISK (TANDON TM 600-2, 3 OR EQUIV.), POWER SUPPLY: +8V/8A, ±16V/3A OVP, +5V/6A OVP, +12V/6A, 8A PEAK. SIZE: 13.75"(W) x 19.5"(D) x 7"(H).

SHIPPING FOR EA. PWR SUPPLY: \$5.50 IN CALIF.; \$8.00 IN OTHER STATES; \$18.00 IN CANADA. FOR EA. TRANSFORMER: \$5.00 IN ALL STATES; \$12.00 IN CANADA. CALIF. RESIDENTS ADD 6.5% SALES TAX.

DEALER INQUIRIES INVITED



No. 806 & No. 516 Mainframes



MAILING ADDRESS:
P.O. BOX 4296
TORRANCE, CA 90510
TELEX: 182558

SUNNY INTERNATIONAL
(TRANSFORMERS MANUFACTURER)
(213) 328-2425 MON-SAT 9-6

SHIPPING ADDRESS:
22129 1/2 S. VERMONT AVE
TORRANCE, CA 90502



DISKETTES

maxell
LIFETIME WARRANTY

5% 5.25/00
28.95

SPECIAL 10% OFF SECOND BOX!

NEW

3M SCOTCH
5% 5.25/00
23.50

VERBATIM

Datalife 24.95
5% 5.25/00
Also Available 5% 5.25/00
21.95

HEAD CLEAN KIT BY VERBATIM - \$5.95

RIBBONS

EPSON (IBM-20) 4.95 EA.
Cartridges Min. 3

CITOH (IBM-20) 7.95 EA.
Cartridges Min. 3

DIABLO 4.95 EA.
Cartridges Min. 3

MEGA-BYTE IND.
4599 S.W. 42nd St.
Ft. Lauderdale, Florida 33314
305-887-1190
NOW OPEN SAT.
10:00 to 3:00 EST.
1-800-327-1013
ASK FOR FREE CATALOGUE

GLOUCESTER COMPUTER

PC/64, all features of Promqueen less mimic mode. Software enhanced to include EPROM QC utilities, RS-232 communication, printouts. 28 pin ZIF socket. Reads, edits runs and programs all 5 volt 2500 and 2700 series EPROMS plus variety of EEPROMS all without personality modules. Commodore C-64 host computer. Inquire about the mimic mode capability in our VIC Promqueen. **\$299.00**

ROM Packs Industrial quality circuit cards are socketed, solder masked, fully bypassed, and include a ground plane for low noise operation. Includes 1 EPROM. 8K & 16K models for VIC-20 and C-64. Specify 2732 or 2764 EPROM type. Molded plastic case. \$39.00

GLOUCESTER COMPUTER

1 Blackburn Center, Gloucester, MA 01930 617-283-7719

WIREMASTER

Whip your wire wrap and PC layout problems with **WIREMASTER**

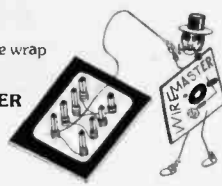

WIREMASTER is a software tool for design, layout, and assembly of hardware. Your schematic is fed to **WIREMASTER**, which produces network maps, cross-references, wire and parts lists, and debug checklists. **CHANGEMASTER** keeps track of fixes and updates. **PLOTBOARD** and **PRINTBOARD** give pictures of the layout. Post-processors for wirewrap machines available. Runs on CP/M, MSDOS, UNIX, and VMS. \$195.

AFTRMTHOUGHT ENGINEERING 7266 Courtney Dr., San Diego, CA 92111, (619) 279-2868.

Circle 289 on inquiry card.

Circle 196 on inquiry card.

Circle 21 on inquiry card.

PC/FORTH™

Complete FORTH program development systems for the IBM® Personal Computer. Packages include interpreter/compiler with virtual memory management, line editor, custom screen editor, assembler, decompiler, utilities, file and record access modules, and many demonstration programs. 150 page user manual. \$100.00

Software floating point, Intel 8087 support, color graphics extensions, and target compiler available at additional cost.

Specify PC-DOS or CP/M-86®. One disk drive and 48 kbytes RAM required. Software supplied on 5 1/4 inch single sided sectored double density diskettes.

Laboratory Microsystems
4147 Beethoven Street
Los Angeles, CA 90066
(213) 306-7412

IBM is a registered trademark of International Business Machines Corp.
CP/M is a registered trademark of Digital Research, Inc.

Circle 263 on inquiry card.

SHIELDED DATA CABLES

Help Protect Your Signals With Shielded Data Cable. EIA RS232 Shielded Cable Specify end gender, length & pin interconnects, up to 9 conductors. \$11.00 + 40/ft.

TERMINALS	Suggested List	Sale Price
Hazeltine-ESPHI Systems		
ESPRIT II terminal w/detachable keyboard	\$845	\$545
ESPRIT III Teletype 950 emulator	\$895	\$735
LOW SPEED MODEMS 0-300 baud		
Novation J-CAT Direct Connect auto anslog modem	\$149	\$99
103 SMARTCAT Smart modem with auto dialer	\$249	\$189
Hayes SMARTMODEM-300 Stackable Smart modem	\$279	\$230
HIGH SPEED MODEMS 0-300/1200 baud		
Novation 103/112 SMARTCAT Smart modem	\$295	\$439
Hayes SMARTMODEM 1200 Stackable modem	\$699	\$535
SMARTMODEM 1200B Smartmodem 1200 for IBM-PC - Smartcom II	\$599	\$485
Universal Data Systems 212LP Telco powered 1200 baud modem	\$445	\$369
PRINTERS		
DAISYWRITER 2000 with 48K buffer and interface cables	1500	\$1286
OKIDATA UL82A 9" carriage 120 cps printer	\$549	\$399
UL83A 15" carriage 120 cps printer	\$899	\$640
UL82P (parallel) 9" carriage correspondence quality	\$859	\$525
UL82S (serial) 9" carriage correspondence quality	\$759	\$529
UL83P (parallel) 15" carriage correspondence quality	\$1249	\$889
UL83S (serial) 15" carriage correspondence quality	\$1349	\$969
TRACTOR for ul82 or ul83 printer		\$60
MISCELLANEOUS		
PERFECT WRITER, PERFECT SPELLER, PERFECT CALC.	**CALL**	
PERFECT FILER MICROPOOLER buffer/interface serial/parallel versions	**CALL**	

Certifying check, money order, COD or VISA-MASTERCARD. Add for postage and handling \$2.50 for cables, \$5 for modems, \$10 for printers and terminals. Michigan residents please add 6% sales tax to sale price.

ELECTROSONICS

38486 Cheldon-Mt. Clemens, MI 48044
(313) 286-6969

Circle 173 on inquiry card.

ZENITH/Heath Users



Double Your 5 1/4" disk storage capacity without adding a drive.

Get twice as much from your H88 or H89 microcomputer. Our FDC-880H floppy disk controller, in conjunction with your 5 1/4" drives, for example, expands memory capacity from 256 bytes to 512 bytes per sector.

And it handles single and double-sided, single and double-density, 8" and 5 1/4" drives — simultaneously.

C.D.R. Systems Inc.
Controlled Data Recording Systems Inc.
7210 Clairmont Mesa Blvd., San Diego, CA 92111
(619) 560-1272

Circle 79 on inquiry card.

MODEMS

IBM-PC

Rixon PC 212A **\$465.00**

- *Plugs into IBM PC card slot
- *300 and 1200 bps. asynchronous
- *Full/Half duplex
- *Automatic dialer, tone or pulse, auto redial
- *Battery protected memory for number storage

PC 212A Software **\$ 49.00**

- *Interfaces PC 212A MODEM to PC
- *Menu driven
- *Stores telephone numbers, log-on procedures

APPLE II, APPLE II PLUS, FRANKLIN, BELL AND HOWELL

Multi-Tech MODEM II **\$265.00**

- *Plugs into I/O slot
- *300 bps asynchronous, full/half duplex
- *Automatic dialer
- *Menu driven software

Pennsylvania residents add 6% sales tax. 90-day return-to-factory warranty. 10-45 delivery. Shipped U.P.S. Check, money order COD to

James Fox Associates 215/598-3293
Brownsburg Road
Box 139B R.D. #2
Newtown, PA 18940

Circle 185 on inquiry card.

Smith-Corona TP-1 Daisy Wheel Printer

only **\$449.00**

UNBELIEVABLE!

- * fully-formed characters
- * compatible with most micro-computers
- * serial or parallel interface
- * choice of 10 or 12 CPM models

Also for your TP-1 letter quality printer—the Smith-Corona Tractor Feed

\$13495

- * Adjustable tractor widths
- * for continuous forms
- * Quick, easy removal



Call Collect (214) 826-6521

FIGURE-LOGIC BUSINESS EQUIPMENT, INC.
6408 Gaston Avenue / Dallas, Texas 75214

Circle 185 on inquiry card.

flexible discs

LOWEST PRICES

wabash MEMOREX

Scotch Verbatim

DEALER INQUIRIES INVITED

CALL COLLECT (614) 866-3462 / 231-1512

datamaster
A DIVISION OF
KOP International Corp.
5145 ZIMMER DR. COLUMBUS, OHIO 43227

Circle 140 on inquiry card.

FORMULA INTERNATIONAL INC.

DEPT. B • 12603 CRENSHAW BOULEVARD • HAWTHORNE, CALIFORNIA 90250 • (213) 973-1921



pinecom™ BREAK THRU!

No more copyright problems!! 100% Apple II Compatible!



- NEW IMPROVED KEYBOARD
- Features:
- Upper/lower case
 - Full size keyboard with numeric key pad
 - Auto repeat keys
 - 25 Pre-programmed function keys
 - 48K RAM user memories can expand to 192K
 - 2W Audio AMP with volume control
 - High resolution color display with graphics
 - 110/220V 5 AMP switching power supply
 - Guarantee to run on CP/M
 - Fully assembled and tested

DIRECT SALE **\$549.00**

(Add 5% shipping and handling)

AUTOTERM™ 80 COLUMN CARD

NEW
\$99.95

- 40/80 column auto-selectable
- with NORMAL/REVERSE and HIGHLIGHT functions
- capable to run PASCAL & CP/M
- SHIFT function as typewriter

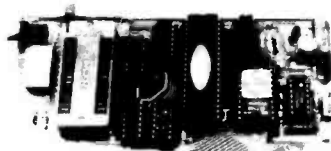
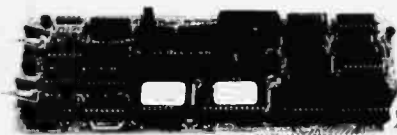

NEW

PART #
900-0080

\$75.00

EPROM PROGRAMMER CARD AP-64e

Program any 2716, 2732 or 2764 EPROMS

- Plug to any slot of your apple computer.
- No extra equipment needed, completely reliable
- Auto blankcheck, compare, read, copy, monitor functions.
- Automatic verify.
- Errors indicated on screen.
- Burning voltage adjustable.
- Dip switch for different EPROMS
- No jumpers required.
- Firmware included.

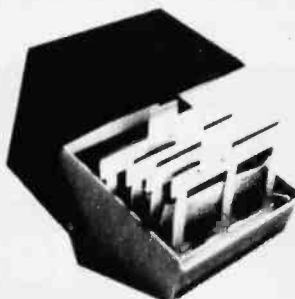

ANTI-STATIC PLASTIC MINI-FLOPPY DISK STORAGE CASE

Holds up to 75 5¼" diskettes
with 4 dividers
color: smoke clear on top
with light brown bottom

MODEL: MINI-FILE
\$19.95 EACH

GREAT INPUT.

Introducing the KoalaPad™ Touch Tablet

- Under \$125 with Micro Illustrator™ software.
- Paddle, joystick, keyboard and mouse in one.
- Perfect for computer graphics, games, education.
- Friendliest controller available—perfect for youngsters.
- For Apple®, Atari®, Commodore®, and IBM® personal computers.
- Compatible with most game and educational software.

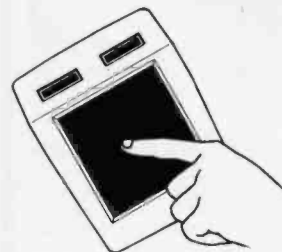

Introductory Offer \$99⁰⁰



80 Column card for Apple IIe®

SPECIAL \$49.95 each

Model: 80C11E

***THIS CARD IS NOT
MADE BY
APPLE COMPUTER**

NEW



HEAVY DUTY JOYSTICK

FOR APPLE+ OR PINECOM COMPUTERS

Metal case with 2 fire buttons, 360 degree
cursor control, auto centering and two fine
trimmer

MODEL: THE COMPATIBLE II **\$34.95**

Apple II + Compatible



THE MICRO-II

The Apple look-alike
and compatible computer,
48K RAM on board with numeric key pad,
upper/lower case keyboard

Fully assembled
Special price

SORRY! ROM SET IS NOT INCLUDED!

\$519.00

*Apple II & Apple IIe are registered trademarks of Apple Computer, Inc. U.S.A.

#187 for Dealer inquiries, #188 for all others

OUTSIDE CALIFORNIA

PHONE ORDERS ONLY 1-800-672-8758 CALL TOLL FREE

• Apple is a registered trademark of APPLE COMPUTERS, INC.

SHIPPING AND HANDLING CHARGES

Under \$50.00 Purchase Over: \$50.00 Purchase

Inside California	10%
Outside Calif. (Incl. Mexico & Canada)	15%
Overseas	25%

5%
10%
20%

SEND \$1.00 FOR OUR DETAILED CATALOG.

Minimum Order \$10.00 / Call! Residents add 6.5%
Sales Tax. Phone Orders Accepted on VISA or MC
ONLY, NO C.O.D.'s. Prices subject to change
without notice.

STORE HOURS
MON-FRI — 10-7
SAT — 10-6

Scotch Diskettes

Rely on Scotch® diskettes to keep your valuable data safe. Dependable Scotch diskettes are tested and guaranteed error-free. The low abrasivity saves your read/write heads. They're compatible with most diskette drives.



(800)235-4137

Dealer Inquiries
Invited



PACIFIC EXCHANGES
1001 Fourth Blvd.
San Luis Obispo, CA
93401 In Calif. call
(805)592-5000 or
(805)541-1000



Circle 341 on inquiry card.

JUKI 6100 LETTER QUALITY PRINTER

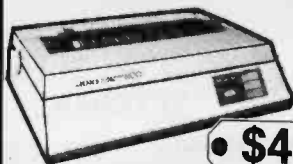

\$499.

- 18 cps
- Word processing and graphic functions
- Proportional spacing control
- Uses IBM Selectric ribbons
- Compatible with Kaypro, IBM, Apple, Osborne, and others.



Free shipping in U.S.



COMPUTERS and more

2420 University Ave., To Order
San Diego, Ca. 92104 (619) 291-1442

Circle 121 on inquiry card.

CRT STAND



**JUST
\$69⁹⁵**

36" W x 24" D x 26 1/2" H

Handsomely crafted stand features a walnut grained plastic laminate top, modesty panel and tubular steel legs with leveling glides. Black baked enamel finish. ORDER No. D2830E... Only \$69.95 ea. Add \$7.95 per stand for shipping and handling. N.Y. and Ca. add applicable sales tax.

PHONE TOLL FREE 800-645-6393
NY 516-292-3400 OR MAIL ORDER TO:



GLOBAL COMPUTER
SUPPLIES

63B Hemlock Dr., Hempstead, NY 11550
Ask for your FREE Computer Supplies Catalog

FREE CATALOG

Circle 195 on inquiry card.

67 MEGABYTE

Removable Storage



Now at an affordable price!

A large capacity cartridge tape system that is file addressable and preformatted to allow random data access. Available with standard interfaces such as SCSI (SASI), S-100, QIC-02, standard & Multibus, GPIB, RS-232C, IBM-PC and Apple II's. Operating software is also available for IBM-PC, PCXT and Apple II, II plus, IIE and III. Send now for additional information.

adic

Advanced Digital Information Company
723 9th Ave. Bldg. A Kirkland, WA 98033

1-800-638-0818

Circle 17 on inquiry card.

EPROM PROGRAMMER

\$193

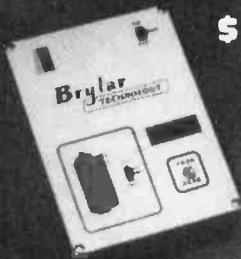

110VAC
RS232
3-wire
7 Bauds

Devices:
(5 volt only)
2716, 32, 32A
2764
27128
25XX series
68766
& MORE!

- Allows read, copy, verify
- Personality by jumpering

Brylar

TECHNOLOGY

(805) 496-0981

2509 THOUSAND OAKS BLVD., SUITE 218
THOUSAND OAKS, CALIFORNIA 91322

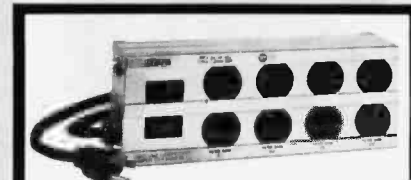

ISOBAR...cleans up your line power! The most complete computer protection available!

More features! To prevent errors, false print-out, disc skips! Only IsoBar has 3-way spike protection, noise suppression for RFI plus isolated filter banks! Prevents components in your system from interfering with each other and erratic line power from damaging the system!

Models \$55 to \$98. Free brochure.
Call 1-312-642-6871 or write:

INDUS-TOOL, Dept. BT
325 W. Huron, Chicago, IL 60610

Circle 225 on inquiry card.

The Ultimate A/B Switch

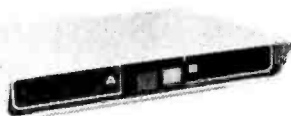

- Ideal for switching serial devices
- Switches 20 signal lines (RS-232)
- Computer grade printed circuit board
- Three 25 pin female "D" connectors
- Attractive brushed aluminum enclosure



A/B Switch in Enclosure..... \$89.95
Assembled PC Board Only..... \$59.95
add \$5.00 postage & handling - NJ residents add 6%
sales tax. Good through September 30th

VISA / MasterCard / AMEX 1-800-223-5656
In New Jersey 201-227-8411

PMI

16 Passaic Avenue
Fairfield, N.J. 07006

Circle 369 on inquiry card.

LSI C Compiler for 8080/Z80

LSI C compiler is designed for programs with a small memory and a shorter CPU time.

- ★ The object code is compact and is faster than leading "C" compilers (Eratosthenes: 13.4sec)
- ★ typedef, static, cast and initializers are available.
- ★ The compiler and the generated code run under CP/MTM, but also can be burnt into PROMs.
- ★ Price: \$500 (FOB Japan)

CP/M is a trademark of Digital Research.

for pamphlet write:
P.O. Box 508 STA. CRUZ
CA. USA 95062

for further information contact:

LSI JAPAN CO., LTD.

2-24-9 YOTOGI SHIBUYA-KU TOKYO (151) JAPAN

PHONE (03) 379-2427

Circle 276 on inquiry card.

CAN YOUR PC SPEAK?

NEW!

SC-02

Speech Synthesizer

★ **GREAT
SOUND**

- Excellent SC-02 speech
- Six voices
- Music & sound effects

★ **SMART**

- Z-80 microprocessor
- Text-to-speech algorithm
- Clock-calender
- Centronics port
- IBM game port

★ **FUN
EASY**

- Educational
- Adds life to programs
- Plug into any IBM slot
- Full software support

PACKAGE PRICE: **\$445**

Universal Computer Products
P.O. Box 4229 • Irvine, CA 92716

Circle 491 on inquiry card.

Alspa Computer, Inc.

Price-performance leader. Includes Z80A, 8" ds/dd drives. 3 serial + 1 parallel port, winchester port, networking. Prices start below \$1500. DEALER / OEM inquiries invited.

SPECIALS on INTEGRATED CIRCUITS

6502	7.45	10/ 6.95	50/ 6.55	100/ 6.15
6502A/6512A	8.40	10/ 7.95	50/ 7.35	100/ 6.90
6520 PIA	5.15	10/ 4.90	50/ 4.45	100/ 4.15
6522 VIA	6.45	10/ 6.10	50/ 5.75	100/ 5.45
6532	7.90	10/ 7.40	50/ 7.00	100/ 6.60
2114-L200		2.45	25/ 2.30	100/ 2.15
2716 EPROM		4.90	5/ 4.50	10/ 4.00
2532 EPROM		6.90	5/ 6.75	10/ 6.45
6116 2Kx8 CMOS RAM		6.90	5/ 6.75	10/ 6.45
4116 RAM				8 for 14
4164 RAM				6.50
Zero Insertion Force 24 pin Socket (Scanbe)				2.00

Hewlett Packard

Write or call for prices.



Anchor Automation Signalman Modems

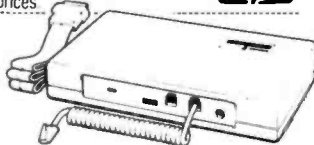

FREE SOURCE MEMBERSHIP WITH SIGNALMAN

All Signalman Modems are Direct Connect, and include cables to connect to your computer and to the telephone. Signalman Modems provide the best price-performance values.

Dealer and OEM inquiries invited

Volksmodem	(79)	55
RS232 or Atari Cable for Volksmodem		9
Mark I RS232	(99)	59
Mark VI for IBM Personal Computer	(279)	179
Mark VII Auto Dial/Auto Answer	(159)	89
Mark XII Smart Model 1200/300	(399)	295
DC HAYES Smartmodem		219
DC Hayes Smartmodem 1200/300		529



PROM QUEEN for VIC		170
Apple Emulator for Commodore 64		Call
STAT Statistics Package for C64		95
Solid Oak 2 Level Stand for C64 or VIC		29
C64/VIC Switch (networking)		125
BACKUP VI.0 tape copier for C64 or VIC		20
CARDBOARD/6 Motherboard - VIC		64
CARDBOARD/5 Motherboard - C64		56
CARDPRINT Printer Interface - C64/VIC		64
CARDBOARD/3s Motherboard - VIC		32
CARDCO C64/VIC Calculator Keypad		32
CARDRAM/16 RAM Expansion - VIC		64
Complete CARDCO Line in stock		
CIE and VIE IEEE Interfaces in stock		
BASM Compiler/Assembler for C64		89

APPLE—FRANKLIN ITEMS

KRAFT Apple Joystick		40
16K RAM Card for Apple		59
Solid Oak 2 Level Stand for Apple		29
Serial Card for Apple		99
MPC RAM/80 column card for IIE (AP/TXT)		139
Z80 Softcard and CP/M (Microsoft)		235
RANA Elite I with Controller		389
Parallel Printer Interface/Cable		79
Apple Dumping (Microtek) Printer Interface		115
Apple Dumping with 16K Buffer		160
Grappier + Interface		129
Kraft Products for Apple in stock		
DC Hayes Micromodem II		299
PFS: File		100
PFS: Report		100
Videx 80 Column Card		209
Hayden Software for Apple 20% OFF		
Apple Blue Book		19

Commodore

See us for Personal, Business, and Educational requirements. Educational Discounts available.

PETSCAN I \$245 base price

Allows you to connect up to 30 CBM/PET Computers to shared disk drives and printers. Completely transparent to the user. Perfect for schools or multiple word processing configurations. Base configuration supports 2 computers. Additional computer hookups \$100 each.

COMPACT/STCP \$115

Intelligent Terminal Package for PET, CBM, C64
Includes ACIA Hardware / STCP Software

VE-2 IEEE to Parallel Interface 110

Includes case, power supply, full 8-bit transmission, and switch selectable character conversion to ASCII.

VIDEO ENHANCER for Commodore 64 69

Realize video quality equal or better than composite monitor using standard color TV.

SCREENMAKER 80 Column Adapter for C64 145

Provides big screen capability for business applications.

GENESIS Computer Corp

VIController (for C64 as well) 50
combine with BSR modules for home or business control

COMSENSE Remote Sensing Adapter for C64 or VIC 35

COM VOICE Synthesizer for C64 or VIC 139

includes software for test to speech, pitch, etc.

COM CLOCK Real Time Clock with battery backup 45

VIC 20 Products and Software in stock

Thorn EMI Software	UMI Software
ABACUS Software	HES Software
16K RAM for VIC	64 Vanilla Pilot

VICTORY Software for VIC and C64

Street Sweepers (VIC)	12	Kongo Kong (VIC)	16
Night Rider (VIC)	11	Cosmic Debris (VIC)	12
Annihilator	16	Adventure Pack I	16
Adventure Pack II	16	Metamorphosis	11
Educational Pack I	11	Trek	12
Strategy Pack I	16	Grave Robbers	12

PAPER CLIP Word Processor 109

ORACLE Data Base from Batteries Included 125

Commodore 64 Programmers Reference Guide 16

MicroChess for C64—8 levels of play 19

Computer's First Book of PET/CBM 11

C64 or VIC SWITCH 125

POWER ROM Utilities for PET/CBM 78

WordPro 3+/64 69

WordPro 4+ - 8032, disk, printer 295

SPELLMASTER spelling checker for WordPro

VISICALC for PET, ATARI, or Apple 189

PET-TRAX PET to Epson Graphics Software 40

SM-KIT enhanced PET/CBM RDM Utilities 40

Programmer's Toolkit - PET ROM Utilities 35

EASY CALC for C64 65

PET Spacemaker II ROM Switch 36

COPYWRITER Word Processor for C64 69

2 Meter PET to IEEE or IEEE to IEEE Cable 40

Dust Cover for PET, CBM, 4040, or 8050 8

CmC Interfaces (ADA1800, ADA1450, SADI in stock)

Programming the PET/CBM (Compute!) — R. West 20

Compute! First Book of VIC 11

HES MODEM with Software 65

HES Software and Hardware in stock

UMI products in stock

FlexFile for PET/CBM/ C64 \$110

Database, Report Writer with calculations, Mailing Lists.

FORTH for PET/C64 full FIG model — Cargill/Riley \$50

Metacompiler for FORTH for independent object code 30

KMMM PASCAL IV.1 for PET/C64 95

EARL for PET/CBM Disk-based ASSEMBLER 65

Super Graphics — BASIC Language Extensions 45

Fast machine language graphics routines for PET/CBM

RAM/ROM for PET/CBM 4K \$75 8K \$90

Commodore Public Domain Software for C64 75

DISK SPECIALS



Scotch (3M) 5" ss/dd	10/ 2.20	50/ 2.00	100/ 1.95
Scotch (3M) 5" ds/dd	10/ 3.05	50/ 2.80	100/ 2.75
Scotch (3M) 8" ss/sd	10/ 2.30	50/ 2.10	100/ 2.06
Scotch (3M) 8" ss/dd	10/ 2.85	50/ 2.70	100/ 2.65

We stock VERBATIM DISKS

Write for Dealer and OEM prices.

Sentinal 5" ss/dd	10/ 1.90	50/ 1.85	100/ 1.80
Sentinal 5" ds/dd	10/ 2.55	50/ 2.50	100/ 2.45

We stock DYSAN disks

Wabash 5" ss/sd	10/ 1.60	50/ 1.55	100/ 1.45
Wabash 5" ss/dd	10/ 1.90	50/ 1.85	100/ 1.75
Wabash 8" ss/sd	10/ 2.00	50/ 1.95	100/ 1.85

We stock MAXELL DISKS

Write for dealer and OEM prices.

Disk Storage Pages	10 for \$5	Hub Rings 50 for \$6
Disk Library Cases	8"—3.00	5"—2.25
Head Cleaning Kits	11	

CASSETTE TAPES—AGFA PE-611 PREMIUM

C-10	10/ .61	50/ .58	100/ .50
C-30	10/ .85	50/ .82	100/ .70

DATASHIELD BACKUP POWER SOURCE 265

Battery back up Uninterruptible Power Supply with surge and noise filtering. The answer to your power problems.

Zenith ZVM-121 Green Phosphor Monitor	95
Zenith new color and monochrome monitors in stock	
MultiPlan—IBM or Apple	185
Quadboard for IBM available	
Peachtext 5000 Software Package	219
PFS Software for IBM and Apple in stock	
VOTRAX Personal Speech System	280
VOICE BOX Speech Synthesizer (Apple or Atari)	
CompuServe Subscription (5 hours free)	35
Dynax (Brother) DX-15 Daisy Wheel Printer	469
Itoh Prowriter Parallel Printer	379
Panasonic 1090 Printer with Correspondence Mode	319
USI CompuMOD 4 R F Modulator	39
Daisywriter 2000 with 48K buffer	1050
Many printers available (Gemini-Star, Brother, OKI, etc.)	

We Stock AMDEK Monitors

Amdek DXY-100 Plotter	590
A P Products	15% OFF
Watanabe Intelligent Plotter 990	6-pen 1290
BROOKS 6 Outlet Surge Suppressor/Noise Filter	54
We stock Electrohome Monitors	
Synertek SYM-1 Microcomputer	189

ALL BOOK and SOFTWARE PRICES DISCOUNTED

Panasonic 12" Monitor (20 MHz) with audio	139
Panasonic CT-160 Dual Mode Color Monitor	259

USI Video Monitors—Green or AMBER 20 MHz hi-res.
Dealer and OEM Inquiries invited

ZENITH data systems

HERO 1 Robot (factory assembled)	2145
Z29 Terminal (DEC and ADM compatible)	680
ZT-10 Intel. Terminal with Serial Port	340
Z100 16-bit/8-bit Systems in stock	CALL
We stock entire Zenith line.	



WE STOCK ENTIRE LINE—write for prices.
Software for Atari in stock.

215-822-7727

252 Bethlehem Pike
Colmar, PA 18915

A B Computers

WRITE FOR CATALOG. Add \$1.50 per order for United Parcel.
We pay balance of UPS surface shipping charges on all prepaid orders
(add extra for mail, APO/FPO, air). Prices include cash discount.
Regular prices slightly higher. Prices subject to change.

5 1/4" DISK DRIVES

TANDON

★ **TM 100-1**
Single Sided, 40 TRK/Side
Single Or Double Density **\$17900**
Free Shipping

★ **TM 100-2**
Double Sided, 40 TRK/Side
Single Or Double Density **\$23900**
Free Shipping

CDC

★ **9409**
Double Sided, 40 TRK/Side
Single Or Double Density **\$23900**
Free Shipping

Order Toll Free
1-800-531-5475 (Outside Of Texas)
(512) 250-1489 (In Texas)
"If We Can't Ship The Next Working Day,
We Won't Take The Order."
MasterCard ★ VISA ★ Check
Texas Residents Add 5% Sales Tax.



**13010 Research Blvd., Suite 101
Austin, Texas 78750**

Circle 95 on inquiry card.

ScreenWiz FULL SCREEN CONTROL

An assembler subprogram you call from your programs to handle screen input/output as IBM mainframes do. Define full screen format specifications outside your program, and call ScreenWiz to retrieve the formats, and do all the I/O for you.

- One command input/displays a full screen
- Use all of your CRT video attributes
- Define up to 24 function keys
- Define templates for display and Input.
- Validate Input while keying. Insert and delete characters to correct fields
- Tab fields forward and backward
- Draw figures using vertical field displays
- Save memory as only one format needs to be in memory at one time. Make the constants to display virtual, and they don't use any memory at all.
- Build help screens. Call them with one function key then return to where you were.

Available now for most popular —

BASIC	IBM PC	\$99
COBOL	CP/M - 80	\$99
FORTRAN	Shipping	\$ 6
PASCAL	Source code included	

INTERDATA SYSTEMS INC.

15 Toronto St. Suite 700
Toronto, Ont. Canada M5C 2E7
(416) 366-2136 (call collect to order)

Visa, M/C
Am. Express

Circle 237 on inquiry card.

REFERENCE—REPAIR FOR THE APPLE II® COMPUTER

For the Technician: Theory of operation. complete schematics (all revisions) scope & test point documentation with scope photos & I.C. logic guide.

For the Novice: Step by step disassembly instructions for computer and disk drive. I.C. replacement charts, and trouble-shooting information in laymans terms.

The first complete reference and repair guide for the Apple II® or Apple II Plus™ Computers with the Disk II Drive & controller.

Money Back Guaranteed
Only **\$45.00** postpaid (U.S.)

Digital Defl Visa & MasterCard Accepted
2632 W. Baseline C.O.D. (add 1.65)
Mesa, Arizona 85202 Outside U.S. (Add 3.50)
(602) 831-5064

*Coming Soon: Reference-Repair for the
Apple Ite® & Franklin Ace 1000™*

Circle 149 on inquiry card.

FLOPPY DISK-DRIVE REPAIR

Command Services exclusively repairs **Tandon** and **Shugart** disk drives. We are affordable, fast and experienced.

For service, call toll free:
1-800-782-5500
In New York State call:
1-800-323-1800

Command Services Corporation
7143 Henry Clay Blvd.
Liverpool, New York 13088
315-457-1432

Circle 89 on inquiry card.

PRINTERS



Epson:

RX 80	\$Call
FX 80	\$Call
FX 100	\$Call

Star-Micronics:

Gemini-10X	\$299
Gemini-15	\$439

Free Shipping ★ Order Toll Free
All Hardware Has Factory Warranty
1-800-531-5475 (Outside Of Texas)
(512) 250-1489 (In Texas)



**13010 Research Blvd., Suite 101
Austin, Texas 78750**

Circle 96 on inquiry card.

CONVERSE WITH YOUR COMPUTER

AT LAST! A FULL IMPLEMENTATION of the original ELIZA program is now available to run on your microcomputer!

Created at MIT in 1966, ELIZA has become the world's most celebrated artificial intelligence demonstration program. ELIZA is a non-directive psychotherapist who analyzes each statement as you type it in and then responds with her own comment or question—and her remarks are often amazingly appropriate!

Designed to run on a large mainframe, ELIZA has never before been available to personal computer users except in greatly stripped down versions lacking the sophistication which made the original program so fascinating.

Now our new microcomputer version possessing the FULL power and range of expression of the original is being offered at the introductory price of only \$25. And if you want to find out how she does it for tech her to do more, we will include the complete SOURCE PROGRAM for only \$20 additional.

Order your copy of ELIZA today and you'll never again wonder how to respond when you hear someone say, "Okay, let's see what this computer of yours can actually do!"

ELIZA IS AVAILABLE IN THE FOLLOWING FORMATS:

1. 5 1/4 inch disk for the 48K Apple II, II Plus, IIe or III \$25 for Protected Version—\$45 for AppleSoft Source Version
2. 5 1/4 inch disk for the 64K IBM Personal Computer \$25 for Protected Version—\$45 for IBM Disk BASIC Source Version
3. 5 1/4 inch disk or tape cassette for the Commodore 64 (specify which) \$25 for Protected Version—\$45 for C-64 BASIC Source Version
4. Standard 8 inch single density disk for all CP/M based computers \$25 for ELIZA.COM—\$45 with Microsoft BASIC-80 Source
5. 5 1/4 inch disk for most CP/M based computers (specify computer) \$25 for ELIZA.COM—\$45 with Microsoft BASIC-80 Source

Please add \$20 shipping and handling to all orders
(California residents please add 6% sales tax)

ARTIFICIAL INTELLIGENCE RESEARCH GROUP
921 North La Jolla Avenue, Dept. B
Los Angeles, CA 90046
(213) 656-7368 (213) 654-2214
M/C, VISA and checks accepted



Circle 45 on inquiry card.

Electronic Circuit Analysis

- AC and DC analysis
- Very fast, optimized machine language
- Worst case, sensitivity analysis
- Sweep component values
- 64 Nodes
- Compare circuits
- Log or linear sweep
- Full file handling
- Full editing, error trapping
- Frequency response, magnitude and phase
- Complete manual with examples
- Transmission lines
- Complex y parameters
- Available for CP/M, MSDOS, TRSDOS
- Price - \$150.00

Tatum Labs
P.O. Box 698
Sandy Hook, CT 06482
(203) 426-2184

Circle 458 on inquiry card.

HOBBY ROBOT-X™

PUT YOUR COMPUTER TO WORK



Robot 1.2 axis arm with magnetic letter and optional pen holder for plotting and drawing. Interfaces to TImex, ViC-20 and other computers. A good introduction to articulated arm robots. Usable for game playing and multi-color plotting.

ROBOT 1 2 AXIS ARM KIT	\$125
ROBOT IV ARM WITH VISION KIT	\$200
VISION 1 PANORAMIC SCAN VISION KIT	\$100

Many other vision systems.
Ask for catalog.

SPECTRON INSTRUMENT
1342 W. Cedar Ave. Denver, CO 80223
Telephone (303) 744-7088



Circle 439 on inquiry card.

SMITH-CORONA Memory Correct III Messenger Printer & Typewriter



- RS232 Serial Or Centronics Parallel
- Multiple Pltch 10, 12, 15

Order Toll Free: \$579
Free Shipping

1-800-531-5475 (Outside Of Texas)
(512) 250-1489 (In Texas)



**13010 Research Blvd., Suite 101
Austin, Texas 78750**

Circle 97 on inquiry card.

Apple Country Ltd. has your Number for ROCK BOTTOM PRICES



1-800-222-2602

MONITORS

AMDEK COLOR I PLUS	299.95
AMDEK COLOR II	439.95
AMDEK COLOR II PLUS	449.95
AMDEK COLOR III	369.95
AMDEK COLOR IV	749.95
AMDEK VIDEO 300 (GREEN)	134.95
AMDEK VIDEO 300 (AMBER)	149.95
AMDEK VIDEO 310 (AMBER)	164.95
BMC 12AU 12" GREEN	89.95
BMC 12EUN 12" GREEN	139.95
BMC AU9191U 13" COLOR	299.95
BMC 1401 13" RGB COLOR	349.95
BMC AU9191MU 13" RGB IBM	629.95
COMMODORE COLOR MONITOR	269.95
COMREX 13" COLOR W/SOUND	294.95
COMREX 12" HI-RES AMBER	149.95
COMREX 12" HI-RES GREEN	139.95
COMREX 12" HI-RES YELLOW	144.95
ELECTROHOME 9" GREEN	129.95
ELECTROHOME 12" GREEN	149.95
ELECTROHOME 13" RGB IBM	379.95
ELECTROHOME 13" RGB COLOR	369.95
GORILLA 12" GREEN	89.95
NEC 12" GREEN SCREEN	154.95
NEC 12" ECONO GREEN	109.95
NEC 12" LO-RES COLOR	299.95
NEC 12" AMBER SCREEN	164.95
NEC 12" COLOR - IBM	539.95
PRINCETON GRAPHICS HX-12	489.95
QUADCHROME RGB FOR IBM	527.95
SAKATA 13" COLOR	264.95
SAKATA 13" RGB COLOR	519.95
SAKATA SUPER RGB MONITOR	719.95
SAKATA 13" GREEN	104.95
TAXAN 12" GREEN	124.95
TAXAN 12" AMBER	129.95
TAXAN RGB VISION I	294.95
TAXAN RGB VISION III	494.95
ZENITH 12" GREEN	99.95
ZENITH RGB COLOR MONITOR	579.95
USI 9" AMBER MONITOR	129.95
USI 9" GREEN MONITOR	119.95
USI 12" GREEN MONITOR	139.95
USI 14" LO-RES COLOR	289.95

MODEMS

ANCHOR MARK I (RS-232)	79.95
ANCHOR MARK II (ATARI)	79.95
ANCHOR MARK III (TI99/4A)	99.95
ANCHOR MARK V (OSBORNE)	94.95
ANCHOR MARK VI (IBM PC)	199.95
ANCHOR MARK VII (RS-232)	109.95
NOVATON J-CAT	104.95
NOVATON 212 AUTO CAT	579.95
SMARTCAT 212 (1200 BAUD)	429.95
SMARTMODEM 300 BAUD	194.95
SMARTMODEM 1200 BAUD	484.95
SMARTMODEM 1200B - IBM	449.95

PRINTERS

AMDEK 2 DIGITAL PLOTTER	1074.95
ANADEX DP-9501A	1319.95
ANADEX DP-9925A	1549.95
ANADEX DP-9629A	1429.95
ANADEX WP-6000	2199.95
ANADEX WP-6000 TRACTOR	144.95
CENTRONICS 352DP	1799.95
COMREX CR-1 DAISY WHEEL	729.95
DAISEYWRITER 2000	1129.95
DIABLO 630R155	1784.95
EPSON FX-80 W/TRACTOR	LOW!!
EPSON RX-80	LOW!!
EPSON FX-100 F/T	LOW!!
GEMINI 10X	LOW!!
GEMINI 15	LOW!!
GEMINI STY-80	LOW!!
GORILLA BANANA PRINTER	189.95
IDS MICROPRISM	479.95
IDS PRISM 132	1299.95
IDS PRISM 132C - COLOR	1499.95
JUKI 6100 PRINTER (P)	549.95
MANNESMANN TALLY MT160L	779.95
MANNESMANN TALLY MT1602	1289.95
MANNESMANN TALLY MT1802	1499.95
NEC 3550 SPINWRITER-IBM	1754.95
NEC 8023 PRINTER	459.95
NEC 8025 120 CPS 136 COL	719.95
OKIDATA MICROLINE 80	339.95
OKIDATA PACEMARK 2350P	1999.95
OKIDATA PACEMARK 2350S	2199.95
OKIDATA PACEMARK 2410P	2329.95
OKIDATA PACEMARK 2410S	2499.95
OKIDATA TRACTOR 80,82,92	49.95
OKIDATA 82A W/GRAPHICS	449.95
OKIDATA 83A W/GRAPHICS	699.95
OKIDATA 84P	1049.95
OKIDATA 84S	1129.95
OKIDATA 92	494.95
OKIDATA 93P	929.95
OKIDATA 93S	994.95
OLYMPIA TYPEWRITER/PRINT	819.95
PANASONIC KX-P1090	419.95
STARWRITER (DAISY)	1549.95
PROWRITER I PRINTER	344.95
PROWRITER II PRINTER	619.95
C ITOH 8600BP	979.95
QUME SPRINT 11/40+	1399.95
SANYO PR5500 DAISY WHEEL	579.95
SILVER-REED DAISY WHEEL	799.95
SMITH CORONA TP-1	499.95
STARWRITER DAISY WHEEL	1549.95
TOSHIBA P-1350	1649.95
TRANSTAR 315 COLOR	449.95
TRANSTAR 130 18CPS	729.95
TRANSTAR 140 40CPS	1229.95
EPSON SERIAL (RS-232)	134.95
GRAFITTI CARD	84.95
GRAPPLER +	119.95
MICROBUFFER II 16K	194.95
PKASC INTERFACE	129.95
WIZARD BPO 16K	129.95
WIZARD SOB 16K	179.95

OTHER PRINTERS AVAILABLE

COMPUTERS

COMMODORE 64	LOW!!
COMMODORE 1541 DRIVE	LOW!!
ATARI 600XL	\$CALL
ATARI 800XL	\$CALL
IBM PC & XT	LOW!!
COLUMBIA VP PORTABLE	2349.95
COLUMBIA COMPLETE SYS.	2649.95
IBM-PC COMPATIBLE SYSTEM	
128K, 2-DS/DD DRIVES, KEYBOARD AND COMPLETE SOFTWARE PACKAGE	
CORVUS CONCEPT MC68000	\$4999
256K, 8" FLOPPY DRIVE COMPLETE SOFTWARE PACKAGE	
BI-DIRECTIONAL 8-1/2X11 SCREEN	
CORVUS CONCEPT 512K	\$5895
CORONA DESKTOP PC	LOW!!
IBM-PC COMPATIBLE SYSTEM	LOW!!
128K 2-DS/DD DRIVES, KEYBOARD COMPLETE SOFTWARE PACKAGE	
CORONA PORTABLE PC	LOW!!
EAGLE PC 128K SYSTEM	2249.95
KAYPRO II	1399.95
NEC APC-H01	\$2495
NEC APC-H02	\$2995
NEC APC-H03	\$3749
NEC APC-WP51	\$4995
PIED PIPER I	1074.95
Z-80 PORTABLE COMPUTER	
INCLUDES 64K RAM & 1MB DRIVE	
SOFTWARE INCLUDES: CP/M & PERFECT SERIES	
SANYO WBC-1100	1529.95
TELEVIDEO 16-BIT DESKTOP	
128K 8088 5MHZ DUAL 360K DRIVES	
INCLUDES CP/M \$3499.95	
TELEVIDEO 910 TERMINAL	594.95
TELEVIDEO 925 TERMINAL	789.95
TELEVIDEO 970 TERMINAL	1199.95
XEROX 820-II	\$2899
ZENITH Z-120 ALL-IN-ONE	
BUILT-IN GREEN SCREEN	
DUAL DRIVES SPECIAL \$2999.95	
APPLE //e NOW AVAILABLE	
PLEASE CALL FOR OUR LOW PRICE	
FRANKLIN ACE 1000 W/COLOR	LOW!!
FRANKLIN ACE 1200 SYSTEM	LOW!!
ROMAR II (APPLE CLONE)	549.95
DISKETTES	
ELEPHANT DISKETTES SS/SD	16.95
ELEPHANT DISKETTES SS/DD	19.95
ELEPHANT DISKETTES DS/DD	25.95

APPLE //

EASY-80 80 COL VIDEO CARD	
FULLY VIDEK COMPATIBLE	
WORKS WITH WORDSTAR, DBASE, SUPER-TEXT-PRO, BASIC, CP/M, PASCAL. SPECIAL INTRO PRICE	
4TH DIMENSION DRIVE+CTRL	289.95
4TH DIMENSION DRIVE-ONLY	199.95
HAYES MICROMODEM II	259.95
KENSINGTON SYSTEM SAVER	64.95
RANA ELITE I W/CTRL-CARD	359.95
RANA ELITE II W/CTRL	509.95
RANA ELITE III W/CTRL	649.95
SOFTCARD (Z-80 CARD)	234.95
MICRO-SCI A2 W/CTRL-CARD	319.95
ASCII EXPRESS PRO	89.95
BPI GENERAL ACCOUNTING	294.95
DATASAR (REQ Z-80)	194.95
DBASE II (REQ Z-80)	449.95
INFOSTAR (REQ Z-80)	319.95
REPORTSTAR (REQ Z-80)	239.95
SENSIBLE SPELLER	84.95
SPELLSTAR (REQ Z-80)	164.95
SUPERCALC (REQ Z-80)	189.95
SUPER-TEXT PRO 40/80	69.95
VISICALC 3.3	174.95
WORDSTAR W/APPLICARD	324.95
IBM	
LOTUS 1-2-3	LOW!!
DBASE II	429.95
FRIDAY	199.95
HOME ACCOUNTANT PLUS	99.95
QUADLINK APPLE EMULATOR	489.95
SMARTCOM II	89.95
MICROSOFT MOUSE	134.95
PEACHTEXT 5000 SER.9	259.95
PERFECT WRITER	189.95
VISICALC 256K	179.95
CBASIC COMPILER	399.95
MULTI-TOOL WORD W/MOUSE	339.95
VERSAFORM	259.95
C-BASE	139.95
WORDSTAR 3.24	349.95
INFOSTAR	349.95
COMMODORE 64	
CALC RESULT ADVANCED	119.95
CARDCO PARALLEL INTERFACE	64.95
CHOPFLIFTER	34.95
DATA20 Z80 VIDEOPAK	224.95
DATASETTE RECORDER	64.95
FORT APOCALYPSE	27.95
FROGGER	27.95
HES MODEM I	64.95
HOME ACCOUNTANT	59.95
JAWBREAKER	27.95
JUMP MAN	27.95
GRIDRUNNER	27.95
PHARON'S CURSE	24.95
HESMOM	27.95
SCRIPT 64	79.95
VANILLA PILOT	24.95
VIC/64 SWITCH	119.95

We will try to meet or beat any advertised price!
CALL US... WE CAN HELP! 1-800-222-2602

For technical assistance, order status and California calls (619) 765-0239
Apple Country, Ltd., P.O. Box 1099, 2602 Washington St., Julian, Calif. 92036

Terms: We accept American Express. No extra charge for Visa/MasterCard, Cashier's Check, personal check (allow 2 weeks to clear) Shipping & Handling: 5% (\$5 min.); APO FPO Alaska Hawaii & Monitors 5% (\$10 min.) Foreign orders 15% (\$15 min.) All items are new with manufacturer's warranty. Prices are subject to availability & change without notice. Purchase order must include check. California residents add 6% sales tax. Send \$1 (good toward first purchase) for new fall catalog.

Apple Country, Ltd. is a DISCOUNT MAIL ORDER HOUSE for the micro computer industry and is a California corporation not affiliated with Apple Computer Inc. Apple is a trademark of Apple Computer Inc.



COMPUSTAR USERS!

SUPERLETTER is for you!

It's the exciting bi-monthly packed with technical tips, feature articles, display and classified ads plus hardware and software reviews written just for the SuperBrain and CompuStar user.

Now in our third year, we offer:

- Substantial DISCOUNTS on popular nationally-advertised CP/M software.
- A full line of hard-to-find enhanced PROMS, BIOS's and GRAPHICS packages.
- A direct link to thousands of Intertec computer users around the world.

**Subscriptions: \$25 in USA
\$35 foreign**

(Back-issues available at \$3.50)

To order, call or write:

SUPERLETTER

P. O. Box 3121
Beverly Hills, CA 90212
(213) 277-2410

Circle 10 on inquiry card.

High Resolution 19" COLOR RGB Monitor

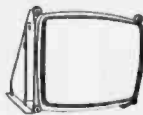

\$519

Ready to plug into IBM PC

- 640 lines x 525
- 6 month warranty available
- specialized cabinets optional



301-268-9331



Overlord Monitors
111 Chinquapin Round Rd.
Annapolis, Maryland 21404

Send for a list of Overlord Monitors

Circle 526 on inquiry card.



8048 IN-CIRCUIT EMULATOR

E232-48 emulates Intel compatible 8048, 8049, 8050 microcomputers and their ROMless and CMOS versions. It features:

- Real time emulation up to 11 Mhz.
- Hardware breakpoints.
- RS-232 interface to host system.
- In-line Assembler and Disassembler.
- Complete debugging facilities.
- Chaining for Multi-Processor emulation.

E232-48 (serial interface) \$1795
E696-48 (S-100 version) \$ 995
Cross Assemblers (8048 & others) \$ 150

SIGNUM SYSTEMS

726 Santa Monica Blvd.
Santa Monica, CA 90401 (213) 451-5382

Circle 424 on inquiry card.

80 CHARACTER VIDEO BOARD

- WORDSTAR/dBASE II OPTION
- TYPE AHEAD KEYBOARD BUFFER



- 25 LINE NON-SCROLL OPTION
- Z80 CPU and 8275 CRTC S-100
- CHARACTER GRAPHICS
- ADAPTABLE SOFTWARE
- ORDER ASSEMBLED & TESTED OR PRE-SOLDERED (ADD YOUR IC'S)

VDB - A2 bare board from \$49.50

Simpliway PRODUCTS CO.
(312-359-7337)

P.O. BOX 601, Hoffman Estates, IL 60195
add \$3.00 S&H, 3% for Visa or Mastercard
Illinois Res. Add 6% Sales Tax
WORDSTAR is a trademark of MicroPro INTERN'L CORP
dBASE is a trademark of ASHTON-TATE CORP.

SAVE BIG ON MEDIA!

SENTINAL™ Complete with hub rings and lifetime warranty

Single sided/Single density 5 1/4" **\$18.70** bx of 10
Single sided/Double density 5 1/4" **\$20.70** bx of 10
Double sided/Double density 5 1/4" **\$27.80** bx of 10
Single sided/Double density 8" **\$29.70** bx of 10
Double sided/Double density 8" **\$38.70** bx of 10

BUY DISKETTES IN BULK & SAVE!

Call For Pricing - From \$179.00/Case Of 100

**SEND FOR OUR ALL NEW
CATALOG! IT'S FREE!!!!!!**

Hundreds Of BIG Bargains:

Peripherals • Software • Games • Accessories
Supplies • Furnitures

CALL TODAY!



1-800-527-3475



Dept. 0-1, 401 N. Central Expwy, Richardson, TX 75080

**ACCESS UNLIMITED
MICRO SHOPPING CENTER**

Circle 11 on inquiry card.

PUBLISHABLE QUALITY GRAPHS on MOST DOT MATRIX PRINTERS

Requires no Graphics Screen
Line Graphs and Scatterplots
Easy to Use, Excellent Manual
CP/M 80, CP/M 86
Most disk formats.
Price: \$50. Manual Alone \$10.

DataPlotter from Lark Software

7 Cedars Rd, Caldwell, N.J. 07006
(201) 226-7552 Visa, M/C

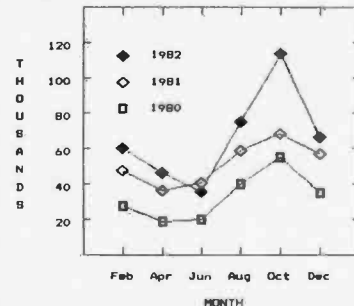

Circle 265 on inquiry card.

BUYING A COMPUTER FOR CHRISTMAS?

SPENDING \$500, \$1500, \$3000?
FIRST SPEND \$9.95 AND FIND OUT
WHAT'S AVAILABLE AND HOW THEY
COMPARE.

THREE PAGE 17" x 22" CHART SHOWING
MOST WELL KNOWN COMPUTERS AND
MANY OTHERS. LISTS CPU TYPE,
OPERATING SYSTEM, DISK SIZE & FOR-
MAT, SOFTWARE AVAILABLE, MEMORY
SIZE, KEYBOARD DESCRIPTION, DISPLAY
SIZE AND RESOLUTION, OPTIONS, PRICE,
ETC.

☆ \$9.95 ☆

AYEWIPS

DEPT. B310
P.O. BOX 10937
DENVER, CO 80210-0937

EXECUTIVE GIFT time is fast approaching. This year save yourself time and money. Let Industrial Ad-Specialty, with 23 years experience in helping companies, do your shopping for you. We represent such prestigious lines as A.T. Cross, Zippo, Sheaffer/Eaton At-A-Glance, Parker, Hazel Vinyl & Leather Products to name only a very few. Call RUTH at 800-523-4330 for a FREE consolidated catalog and consultation.

Industrial

INDUSTRIAL AD-SPECIALTY & LOOSE LEAF MFG. CORP.
THIRTY-FIRST & JEFFERSON STS., PHILA., PA. 19121
(215) 684-1000

Circle 197 on inquiry card.

US Robotics Modems

300/1200 Baud
Autodial/Autoanswer

Password.....\$335
Courier (for Osborne).....\$375
S-100 (for S-100 Systems).....\$335
Autodial 212A.....\$429
Telpac Communication Software.....\$ 69

Morrow MicroDecision

(Includes 64K Ram, Z80A, CP/M, Wordstar, Spelling Checker, Logicalc, BaZic, and Microsoft Basic)

MD-2 (2-200K Drives w/Personal Pearl)....\$895
MD-3 (2-384K Double Sided Drives w/Personal Pearl and Quest).....\$1149
Decision 1.....\$Call

XL Systems

a Division of Data Information Systems, Inc.
967 East 4800 South Suite 4-C
Salt Lake City, Utah 84117

Visa
Mastercard **801-266-0454**

\$3 long dist. credit w/purchase

Circle 136 on inquiry card.

ADVANCED COMPUTER PRODUCTS

Serving Computer Professionals Since 1976

HOOKED ON IBM PC



If You're Thinking IBM PC™,
READ THIS!

LOW COST MEMORY — AVAILABLE NOW!

SEND FOR YOUR FREE 1983 CATALOG!

HARDWARE

AST Megaplus™ Card	List	ACP
P/N MG064 (64K, S. C.)	395	\$279
•Comboplus™ Card		
P/N MC-064SPC (64K, S. P. C.)	395	279
•PC I/O Plus II™ Card		
P/N I/O (C. S.)	165	115
•"SIX PACK"		
P/N SP064SPC (64K, S. P. C.)		299
COEX Extender Card	40	29
Prototype Card	69	35
HERCULES		
Hercules Graphic Card		359
MOUSE SYSTEMS Mouse for IBM		269
MICROSOFT		
Mouse plus Multitool Word		Cell
ORCHID		
Hi-Res Graphics Adaptor	395	339
PERSYST Spectrum (64-256K)		
P/N SP64, (64K, Clk, S. P.)		319
PLANTRONICS Color plus™ Card		399
QUADRAM Quadboard (64-256K)		
P/N Q64, 64K w/4 functions	395	279
QuadLink Apple Card	680	589
Quadboard 64K		279
Microfazer Print Buffer MP-64		190
Quadchrome (Hires RGB)		488
QuadLink (IBM to Apple)		525
RIKON PC212A Modem I/O	596	449
SSM Transmodem 1200		479
USI Multidisplay Card		299
VISTA™ Multicard™ (exp. 64-256K)		
P/N V-064 (64K, Clk, S. P.)	395	229
P/N V-256 (256K, Clk, S. P.)	695	399
•"Maxicard"™ (up to 576K)		
P/N V-576-64K		249
P/N V-576-576K		729
•"PC Master"™ (10 I/O)	495	329
•"PC Extender"™ (up to 10 I/O)	249	199
•"Diskmaster"™	299	199
•8" Thinline Dual Floppy		Cell
•V1200 6.2 Cartridge Drive		999

PRINTERS

COEX 80F T 80cps	\$299	\$199
DYNAX Daisywheel		525
SILVER REED		
EXP500 132 Column		649
STAR MICRONICS - NEW!		
Gemini 10X 120cps	399	319
Gemini 15 15"	599	459
EPSON FX80	699	549
FX100	895	749
BROTHER HR-1 BMC	1195	895
DAISYWHEEL	1495	1295
TTX Daisywheel		549
NEC Spinwriter 3550		1875
IBM PC to Parallel Cable	60	39

MONITORS

AMDEK CORP		
300 Green 12"	\$199	\$155
310 Amber 12"		175
Color I Compositer/Hitachi	399	339
Color II RGB Hi-Res	899	695
BMC		
12" Green	129	89
PRINCETON GRAPHICS		
RGB IBM Lookalike	700	545

DISKETTES

DYSAN 5 1/4" GS SD	10/\$55	\$38
DYSAN 5 1/4" DS SD	10/65	48
IBM 5 1/4" SS SD	10/60	43
IBM 5 1/4" SS DD	10/65	47
VERBATIM 525-01 SS	10/45	23
VERBATIM 550-01 DS	10/55	34
MAXELL MD1 SS	10/50	29
MAXELL MD2 DS	10/60	39
Flip Storage Box 5 1/4" (80 disks)		19
BULK SPECIAL SS	10/25	19
With Sleeve and Box	100/195	149

MORE IBM GOODIES

COMPUABLE		
Keyboard & Drive Covers (set)		\$19
CURTIS		
PC Pedestal	\$80	64
PGS or Quadchrome Adaptor		10
Vertical PC System Stand		20
IBM Mono Extension Cable	50	44
Keyboard Ext. Cable (3-9')		34
EPD PROTECTION DEVICES		
The Lemon (Surge Protector)		43
The Peach (Surge Protector)		58
The Orange (with EMI/RFI)		122
The Lime		76
INTEL 8087 IC		199
KOALA PAD		99
KRAT Joystick IBM	70	40
RAM EXPANSION		
16K Motherboard (16 IC's)		19
64K Memory Exp. (9 IC's)		50

TIME SHARE SERVICES

COMPUSERVE Subscription	\$40
SOURCE Subscription	75

MODEMS

HAYES		
Smartmodem 300	\$210	
PC Modem Software 1.3 (above)		
Smartmodem 1200	\$25	
PC Software 1.4C (above)	79	
Smartmodem 1200B	445	
Smartcom II	79	
Smartmodem to IBM Cable	25	

SOFTWARE

dBASE II
\$399⁰⁰

Condor
\$389⁰⁰

SuperCalc
\$99⁰⁰

SuperCalc 2
\$179⁰⁰

Multiplan
\$189⁰⁰

Wordstar
\$299⁰⁰

Lotus 1-2-3
Call!

T. K. Solver!
Call!

Flight Simulator
\$45⁰⁰

Context MBA
Call!

Computer Innovations

C86C Compiler
\$369⁰⁰

Copy II Plus
\$32⁰⁰

Visiword
\$289⁰⁰

Digital Research
Pascal MT + 86 \$295.00
Concurrent CP/M 86 260.00
CBASIC 86..... 149.00

Plus More Great Software Values In Our 1983 Catalog! Send For Your Copy NOW.

COEX Combocard II

- ★ 64K to 256K RAM
- ★ ASYNC Serial Port
- ★ Clock/Calendar w/NiCad Backup
- ★ Parallel Printer Port
- ★ RAMDisk Software
- ★ Spooler Software

64K only **\$229⁰⁰**

256K only **\$399⁰⁰**

Zero "K" Version Available Only \$199.00

PLUS! . . .with Purchase of either Memory card above

- SUPERCALC™ only \$89.00 (195.00 value)
- Disk Emulator FREE
- Print Spooler FREE

ACP PC "FEATURE OF THE MONTH"

1. DISKMASTER™. Disk Controller for IBM PC or XT adds both 5 1/4" and 8" floppy drives. Complete with Software. Same card can also handle List ACP the Amlyn 6.2 Mb Cartridge Add-on Subsystem \$299 \$199
2. VISTA 1200 with DISKMASTER™ \$999
3. M&R "SUP'R EXTENDER™". IBM PC & XT Expansion Chassis with (6) Slots, Power Supply and Fan. Your price!!! only \$439.00. You cannot afford to live without one.

DISK DRIVES

TANDON 100-2
PC Compatible • Double Sided
\$289⁰⁰

QUME 142 1/2 High
PC Compatible • Double Sided
\$249⁰⁰

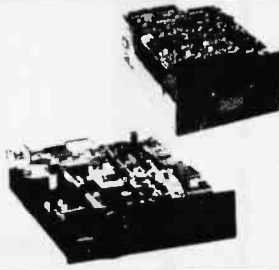

Circle 16 on inquiry card.

TERMS: MO: Cashier's Check Bank Wire. Personal checks allow 2 weeks for processing. Include Drivers License and Credit card #s Visa, AMEX, CB and 3% service charge. Add 3% shipping & handling or \$2.50, whichever is greater. Add 10% for foreign orders or US Parcel Post. Include Telephone number. NO CODs. Prices subject to change without notice. Some items subject to prior sale. We reserve the right to substitute manufacturer. Retail prices may vary. We are not an authorized IBM dealer. IBM™ trademark of International Business Machines.

MAIL ORDER: P.O. Box 17329 Irvine, CA 92713
Retail: 1310 E. Edinger, Santa Ana, CA 92705 (714) 558-8813
542 W. Trimble, San Jose, CA 95131 (408) 946-7010

TOLL FREE
800-854-8230
TWX
910-595-1565

64K MEMORY + P.S.C. \$249.00

**Surplus S-100 Video Digitizers
Godbout System with RCP/M Software**
Digital Graphics CAT-400 hi-res video digitizer and color, raster display boards. Four-bit frame-grabber, 3 color maps (VM-133), RGB, NTSC, RCCU and most other features. \$4,250

Digital Graphics CAT-200 with most features of CAT-400. \$3,250

Digital Graphics CAT-100 ABCFMPSTX (NTSC and RGB output, contouring, frame grabber, character generator, etc.) \$1,250

CAT display RAMS are 128K, 64K, and 32K respectively. CAT-400 displays 240K 4-bit pixels (512 x 480). CAT-200 and 400 have 16-million-color palette using (3) 1K color-mapping memories.

Sony Trinitron 15" TV modified to accept analog RGB or NTSC. \$450

RCA 1005/1" B/W hi-res TV camera w/Fujii 1.4/25mm lens. \$750

Godbout 22-slot S-100 frame, Shugart 4008 26Mb Winchester with Morrow controller, Dual 8" Qume DT8's (1.2 Mb each) with Godbout Disk1, Godbout 6 Mhz Z-80, Interfacer II (2 serial ports), 64K static RAM17, and PMMI 300/450/600 Baud modem in 19" rack plus TVI-920C CRT, CP/M 2.2, and CBIOS source. Operational RCP/M software on request. Online now at (214) 931-8274. \$4,900

All hardware and software documentation included. For full list and details circle reader service number or contact:

D. C. Crane, Inc.
P.O. Box 802614
Dallas, TX 75380-2614 (214) 931-2669

Circle 132 on inquiry card.

**PERIPHERALS FOR
APPLE II AND IIe**

ONE YEAR WARRANTY ON ALL ITEMS

	EACH	BARE BOARD
APPLE/SHUGART DRIVE (5 1/4")	\$199	
DISK CONTROLLER (DDS 3.2-3.3)	59	\$ 21
80 COLUMN CARD (VIDEX EQUIVALENT)	139	29
132 COLUMN CARD (II+ OR IIe) (ULTRATERM EQUIVALENT)	CALL	52
80 COLUMN WITH 64K RAM (FOR IIe ONLY)	129	28
PRINTER INTERFACE WITH 16K TO 64K BUFFER AND GRAPHICS (APPLE DUMPLING EQUIVALENT)	CALL	29
MULTI-FUNCTION CARD (PARALLEL, SERIAL, BSR, CLOCK) (VERSA CARD EQUIVALENT)	136	29
APPLE IIe BARE BOARD	--	175
5 1/4" FLOPPY DRIVE ENCLOSURE	17	
Z80 SOFTWARE (II+ AND IIe) (MICROSOFT EQUIVALENT)	99	29

COLORADO COMPUTER PERIPHERALS
R.R. 6, BOX 7-D GOLDEN, CO 80401
(303) 278-7172

Circle 87 on inquiry card.

Printer Cables

— Parallel —

ALDOS \$35.00*
ATTACHE \$35.00*
ATARI
CENTRONICS
COLUMBIA
EAGLE
IBM-PC
KAYPRO
OSBORNE
SANYO
TI-99 \$35.00*

FREE SHIPPING

— SERIAL —

ATTACHE COM.
RS232 (DB25P)
(9 conductor 1-8, 20)

CABLES UNLIMITED
4030 Wabaska Dr.
San Diego, CA 92107
619-222-3366

*CA Residents Add 6% Sales Tax (\$2.34)

Circle 514 on inquiry card.

Computer Software Associates, an established software house, supplies software for COMMODORE, APPLE, and IBM home computers. CSA is currently looking to expand its product base of serious programs in the areas of home, education, and office.

Computer Software Associates offers over 30 years of market experience, worldwide distribution, innovative packaging, generous royalties, and programmer support.

Interested programmers should contact Mike Mahan, Product Development Department, Computer Software Associates, 50 Teed Drive, Randolph, Massachusetts 02368 Tel. (617) 961-5700.

COMPUTER SOFTWARE ASSOCIATES

Circle 114 on inquiry card.

THE CLONER EPROM DUPLICATOR \$69.95

2715 COPY SIMPLE STAND ALONE OPERATION
2732A 2715 BUILT IN POWER SUPPLY
2732 2732 ONTO DOUBLE PROGRAM CYCLE
DIP SWITCH PERSONALITY

NO MODULES TO BUY
LED INDICATOR RUN & RESET BUTTONS

STORE SEVERAL PROGRAMS ON SAME CARTRIDGE BOARD CONTROLLER PLAY OVER THE PHONE OR LOCAL SCREEN PROMPTS DOCUMENTATION \$24.95

STORES BASIC OR MACHINE PROGRAMS 5 OR MORE VIC TO VIC OR CGA \$19.95 ea. NO CONNECT CHARGES

RE-USABLE CARTRIDGES

CARTRIDGE PROGRAMMER \$79.95 USER FRIENDLY SEND MESSAGES SINK ENEMY SHIPS

WORKS WITH PROGAID \$49.95 SPY MODE SET MINES
& V-MON

MIGHTY 5
5 FULL SERVICE EXPANSION CONNECTORS
SOFTWARE CONTROL OF BLOCK ENABLE LINES
DUAL RESET SWITCHES RESET VIC OR MIGHTY 5
(GOLD CONNECTORS) USES SEVERAL GAMES OR RAM CARDS AT ONCE

These and other fine products available from:
QUEUE PRODUCTS
(313) 846-6666
BOX 1655 / DEARBORN, MI 48121
— DEALER INQUIRY REQUESTED — #28

Circle 87 on inquiry card.

VisiCalc . . . \$50.00*

Castle Wolfenstein \$5.99*

Wizardry \$9.99*

1-2-3 Lotus \$99.00*

PFS: File \$25.00*

Over 1200 Programs To Choose From

SOFTRENT™
*one week rental

Free Catalog:
619-481-0559 San Diego
1-800-221-1031 California
1-800-221-4568 All Others

Circle 430 on inquiry card.

HEXADAISY™



HEXADAISY™ is a hexadecimal circular slide rule with waterproof printing. The device calculates the offset for relative addressing used in many microprocessors, adds and subtracts hexadecimal numbers, calculates 2's complements and converts decimal to hexadecimal numbers and back. HEXADAISY™ with instructions is available ppd. for \$4.95, (CA res. add \$.30) from

HEXADAISY™ PRODUCTS
P.O. Box 1532, Laguna Beach, CA 92652
Tel. 714-494-8342

Circle 114 on inquiry card.

PROMPT DELIVERY! AND TRY TO BEAT THESE IC PRICES:

DYNAMIC RAM		
64K	200 ns	\$5.27
64K	150 ns	5.47
64K	120 ns	6.55
16K	200 ns	1.49
EPROM		
27128	300 ns	\$19.20
2764	250 ns	6.35
2732	450 ns	3.89
2732A-2	200 ns	5.67
2716	450 ns	3.19
2532	450 ns	4.60
STATIC RAM		
6264P-15	150 ns	\$33.00
6116P-3	150 ns	4.79
6117P-3	150 ns	4.20
Z80A FAMILY		
CPU, CTC, or P10		\$2.94
DART		7.99
DMA or S100		12.50

MasterCard VISA or UPS CASH COD
Factory New, Prime Parts

MICROPROCESSORS UNLIMITED
24,000 South Peoria Ave. (918) 267-4961
BEGGS, OK, 74421

Prices \$ 12.83
Prices subject to change. Please expect higher prices on some parts due to world wide shortages. Call for volume prices. Subject to available quantities. Shipping & insurance extra. Cash discount prices shown.

Circle 307 on Inquiry card.

DDE INC.

Dealing Discounts Everyday

OCTOBER TREATS
(No Tricks)

	LIST	SALE
dBASE II	700	399
ZORK I, II, III	40	27
[8" CP/M]	50	34
THE ARCADE MACHINE	60	40
PRINTERS:		
160 CPS-MT 160L	798	598
132 COL-MT 180L	1098	829

PRICES GOOD THROUGH 10/31/83
Please include 3% for Shipping (minimum \$2.00), or 5% for Blue Label (minimum \$3.00). In Texas Add 5% Sales Tax.
CHECK (Allow 10 Days), or COD (add \$2.00)

1-800-527-7127 P.O. BOX 64844
IN TEXAS 1-214-525-3230 DALLAS, TX 75206

Circle 134 on inquiry card.

MICROSOFT

A.L.D.S.	75.99
APPLESOFT COMPILER	116.99
BASIC COMPILER (APPLE, IBM)	259.99
FLIGHT SIMULATOR (IBM)	34.99
MOUSE WITH WORD	\$Call
MULTIPLAN (ALL FORMATS)	165.99
PREMIUM PAK (APPLE)	479.99
SOFTCARD (APPLE)	215.99
TYPING TUTOR II (APPLE)	16.99

Novation

APPLE CAT II	285.99
APPLE CAT 212 (UPGRADE KIT)	319.99
AUTO CAT 212	579.99
D-CAT	155.99
EXPANSION MODULE	34.99
INFONE (EXECUTIVE)	779.99
J-CAT	104.99
SMART CAT 103	169.99
SMART CAT 103/212	429.99

QUADRAM

APIC (APPLE III PARALLEL)	129.99
E-RAM (APPLE)	129.99
512 + (64K)	269.99
IPIC (IBM PARALLEL)	89.99
MICROFAZER	\$Call
QUADBOARD 64K	279.99
QUADCHROME MONITOR	529.99
QUADCOLOR I	269.99
QUADLINK	622.99

apple

ALS CPM 3.0	299.99
BANK ST. WRITER	44.99
BPI (GL. AP. AR. INV.) ea.	299.99
COPY II PLUS	22.99
DB MASTER	159.99
DEADLINE	32.99
FINGERPRINT	44.99
GRAFORTH	54.99
GRAPPLER +	119.99
HAYES MICROMODEM	255.99
HAYES 1200 BAUD	499.99
MAGICALC	139.99
MAGIC WINDOW II	169.99
MINER 2049er	28.99
MTN CLOCK	189.99
MTN CPS	149.99
MTN MUSIC SYSTEM	289.99
PAYMAR L/CASE REV 7	19.99
PIE WRITER	109.99
TG JOYSTICK	46.99
TIME ZONE	74.99
ULTAMA II	38.99
VISICORP	\$Call
WILDCARD	109.99
WIZARDRY	32.99
WORDHANDLER II	129.99
ZAXXON	34.99
ZORK I, II, III	24.99

POTPOURRI

BROTHER/DTC RIBBONS	2.99
DYSAN 104/1D SS/DD(10)	37.99
DYSAN 104/2D DS/DD(10)	44.99
FLIP FILE (STORES 75)	17.99
LIBRARYCASE (STORES 10)	1.99
MX 80 RIBBON	4.99
MX 100 RIBBON	9.99
PAPER(8 1/2 x 11-1000 SHTS)	16.99
POWER STRIPW/SURGE	24.99
TPI RIBBONS	5.99
VERBATIM SS/DD (10)	25.99
VERBATIM SS/DD (100)	239.99

Continental

HOME ACCT (A, AT, TRS 80)	44.99
HOME ACCT (OSB)	59.99
HOME ACCT (IBM)	99.99
FCM (APPLE)	65.99
FCM (IBM)	84.99
PROP. MANAGEMENT	299.99
CPA (GL AP, AR, PAY)	159.99
TAX ADVANTAGE	39.99
ATARI SOFTWARE 1983	14.99
APPLE SOFTWARE 1983	14.99
APPLE GRAPHICS	14.99

IBM

APPLE PANIC	23.99
CDEX TUTORIALS	59.99
CONCURRENT C/P/M 86	252.99
COPY II PC	25.99
COSMIC NIGHTMARE	22.99
CPM 86	44.99
CROSSTALK	149.99
d BASE II	419.99
DEADLINE	32.99
EASY FILER	289.99
EASY WRITER II	259.99
HAYES SMARTCOM II	89.99
HAYES 1200B MODEM	479.99
INFOSTAR	289.99
LOTUS 1-2-3	329.99
MILLIONAIRE	49.99
MONTE CARLO 64K	359.99
PFS FILE	99.99
PSF REPORT	89.99
PLANTRONICS COLOR+	399.99
Q-BASE	139.99
TEMPLE OF APSHAI	26.99
TK SOLVER	139.99
VISIWORD	298.99
VOLKSWRITER	149.99
WORDSTAR	289.99
ZORK I, II, III	24.99

Beagle Bros

ALPHA PLOT	24.99
APPLE MECHANIC	19.99
BEAGLE BAG	19.99
DOS BOSS	15.99
DOUBLE TAKE	24.99
FLEX TEXT	19.99
FRAME-UP	19.99
PRONTO DOS	19.99
TIP DISK #1	14.99
TYPEFACES	14.99
UTILITY CITY	19.99

Videx

CHARACTER ROMS	24.99
ENHANCER II	99.99
FUNCTION STRIP	56.99
INVERSE VIDEO	19.99
PSIO	169.99
SOFTSWITCH	24.99
ULTRATERM	299.99
VIDEOTERM	199.99
VIDEOTERM UTILITIES	24.99
VIDEOTERM W/SS&INV	229.99
VISICALC MEM EXPAND	59.99
VISICALC PRE BOOT	32.99

KENSINGTON MICROWARE

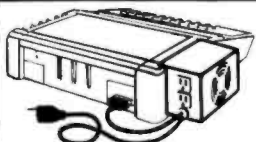

SYSTEM SAVER

- Surge Suppression
- Dual Outlet
- U.L. Listed
- Fits Apple Stand

\$65

KRAFT

JOYSTICK	44.99
JOYSTICK (AT)	14.99
PADDLES	31.99
QUICK-VIS	14.99

SORCIM

SPELLGARD	129.99
SUPERCALC	129.99
SUPERCALC II	179.99
SUPERWRITER	179.99

EDUCATIONAL

BUMBLE GAMES	29.99
DLM	\$Call
EDUWARE	\$Call
FACEMAKER (A, IBM)	24.99
GAME SHOW (MASTER)	29.99
GERTRUDE'S PUZZLES	29.99
JUGGLES' RAINBOW	21.99
KINDERCOMP (A, IBM)	20.99
MATH BLASTER (IBM)	34.99
MICRO MOTHER GOOSE	29.99
ROCKY'S BOOTS	34.99
SNOOPER TROOPS (A, IBM)	29.99
STORY MACHINE	24.99
WORD ATTACK (IBM)	34.99

USI

PI 1 9" GREEN	95.99
PI 2 12" GREEN	139.99
PI 3 12" AMBER	149.99
PI 4 9" AMBER	129.99

SATURN SYSTEMS

ACCELETATOR	529.99
NEPTUNE (80 col + RAM)	199.99
SATURN 128K (APPLE)	399.99
TITAN 64K (IBM)	549.99

SMITH-CORONA

TP-I



Letter Quality Printer

\$479.99

TRACTOR FEED 149.99

PRINTERS

BROTHER HR1	699.99
EPSON (ALL MODELS)	\$Call
GEMINI 10X	299.99
GEMINI 15	429.99
OKIDATA 82A	379.99
OKIDATA 92	529.99

DTC

380 Z	1099.99
48K BUFFER; 32 CPS;	
GRAPHICS, DAISY WHEEL	
TRACTOR	159.99

- No Charge For Credit Cards
- Prices Subject To Change
- Software Sales Are Final
- Min. \$4.00 Shipping Charge
- Purchase Orders Call First



COMPUTER DISCOUNT PRODUCTS

MAIL ORDERS & RETAIL STORE
860 S. Winchester Blvd.
San Jose, CA 95128
(408) 985-0400 Orders Only
(408) 985-0401 Sales & Tech. Asst.



HOURS: MON-FRI 8AM-5PM - SAT & SUN 10AM-5PM

\$\$ Printers \$\$

\$\$ WE WILL NOT BE UNDERSOLD \$\$

Special Sale

Communications Pak

Hayes Smartmodem 300/1200	\$499
Hayes Micromodem II	279
Apple Cat II	282
J Cat	129
Anchor Mark I RS232	89
Anchor Mark VII aut.	139

DISK DRIVES

Rana Elite I	289
Rana Elite II	435
Rana Elite III	575
Rana Controller w/drive	75
Apple Ace Mate (1 yr. warr)	239
Silm Teac 5 1/4" (1 yr. warr)	269

THE COMPUTER STORE

Dept. 345
3941-B South Bristol St.
Santa Ana, CA 92704
714-261-1383

ORDERS ONLY: (800) 824-2227

Circle 115 on inquiry card.

POWER PROTECTION FOR YOUR SYSTEM



The Datasaver™ AC Power Backup fits most desktop and portable microcomputer systems. Call Cuesta Systems, Inc. at (805) 541-4160 for product information and application literature.

VISA/Mastercard orders.
INSTANT POWER

Circle 129 on inquiry card.

UNIX*?

The Independent UNIX Bookstore provides the most complete selection of UNIX and C materials available anywhere. 40 titles, reference cards, posters and T-shirts in stock!

NEW NEW NEW

Responses from UNIX Commands, by Henry McGilton and Rachel Morgan, explaining cryptic UNIX messages to its users! \$25.00 plus \$2.50 shipping and handling.

QUANTITY DISCOUNTS AVAILABLE

No Purchase Orders under \$100.
Write or call

The Independent UNIX Bookstore,
International Technical Seminars, Inc.,
520 Waller St., SF, CA 94117
(415) 621-6415

*International Technical Seminars is not associated with Bell Labs
*UNIX is a Trademark of Bell Laboratories

Circle 234 on inquiry card.

FAST Factory Floppy Disc Drive Repair

Specialists in the repair of:

Shugart
Tandon
PerSci

PERSci, Inc.



12624 Daphne Avenue
Hawthorne, CA 90250
(213) 777-7536
TWX 910-321-4448

Circle 356 on inquiry card.

64K for VIC 20™ SELECT-A-RAM™



SELECT-A-RAM

STANDARD FEATURES

- 8K BLOCKS SELECTABLE FROM THE KEYBOARD OR BY SOFTWARE COMMAND
- TWO EXPANSION SLOTS
- WRITE PROTECTION
- RESET SWITCH
- EXPANDABLE TO 128K WITH ADDITION OF 64K EXPANSION MODULES
- COMPATIBLE WITH ROM CARTRIDGES
- ONE YEAR WARRANTY ON PARTS AND LABOR
- 15 DAY MONEY BACK GUARANTEE

SELECT-A-RAM

44K EXPANSION MODULE \$168.

TRADE INS ACCEPTED \$148.

36 5 1/2" 5 1/4" 104 520

VIC 20 IS A TRADEMARK OF COMMODORE ELECTRONICS LIMITED

512-441-3202 PO BOX 43006 Austin, Tx. 78745-0001

MasterCard

ADVANCED-PROCESSOR SYSTEMS

VISA

APS-52A

52K MEMORY FOR ATARI

400/800 \$119.00

The APS-52A memory expansion boards come assembled and tested with a 90 day warranty covering materials and accessories.

Boards come with complete documentation including operation and evaluation instructions and a memory test program.

TRADE INS ACCEPTED \$10.00

ATARI 400 AND 800 ARE TRADEMARKS OF ATARI INC.

Circle 19 on inquiry card.

Apple II/IIe® Industrial Control Plug-In Boards (SOFTWARE INCLUDED)

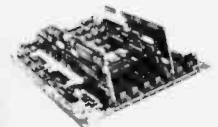

Opto-Isolated 16/32 I/O Board

- Individually Configurable
- Compatible with SSR Modules
- Opto-Isolated Interrupt Inputs

\$295

2 Axis Stepper Motor Interface

- Positioning Control
- Pulse Counting/Timing
- Frequency Measurements

\$195

ROGERS LABS (714)751-0442
2710 S. Croddy Way, Santa Ana, CA 92704

Circle 404 on inquiry card.



HAVE YOU TRIED THE
DYSAN®
QUALITY
DIFFERENCE?

DEALER INQUIRIES INVITED

5 1/4"

PRICE/10

104/1	1 SIDE/SGL DENS.	\$35.00
104/1D	1 SIDE/DBL DENS.	\$37.00
104/2D	2 SIDES/DBL DENS.	\$43.90
204/1D	1 SIDE/QUAD 96 TPI	\$43.90
204/2D	2 SIDES/QUAD 96 TPI	\$51.30

8"

3740/1	1 SIDE/SGL DENS.	\$36.50
3740/1D	1 SIDE/DBL DENS.	\$45.20
3740/2D	2 SIDES/DBL DENS.	\$52.70

Checks-VISA-MC-C.O.D./Add \$2 Shipping
Call or write for our discount catalog.

LYBEN COMPUTER SYSTEMS

27204 Harper Ave., St. Clair Shores, MI 48081
Phone: (313) 777-7780

THE DYSAN DISKETTE STANDARD AT AN AFFORDABLE PRICE

Circle 277 on inquiry card.

Exclusively UNIX* and C Information

That's UNIQUE, the oldest and largest monthly newsletter covering the UNIX* and C marketplace.

* product reviews/listings/prices

* applications/tutorials/indexes

* Industry inside information

Full year, \$54 (\$70.00 Foreign) -write, call or circle reader service number for full brochure and FREE sample copy.

InfoPro Systems

Dept. B • Box 33 • E. Hanover NJ 07936
(201) 625-2925

*UNIX is a trademark of Bell Laboratories
Formerly The UNIX Software List

Circle 227 on inquiry card.

Verbatim flexible disks

Call Free (800) 235-4137 for prices and information. Dealer inquiries invited. C.O.D. and charge cards accepted.

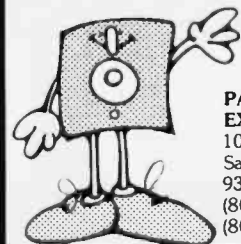

VISA

PACIFIC EXCHANGES
100 Foothill Blvd.
San Luis Obispo, CA 93401. In Cal. call (800) 592-5935 or (805) 543-1037.

Circle 341 on inquiry card.

Prices the Competition Can't Touch

IBM Specials

Advanced Operating Systems	
The Programmer	\$129
Applied Software	
Versaform	\$249
Ashton-Tate	
dBase II (CP/M86)	\$419
dBase II (MS DOS)	\$419
Continental Software	
The Home Accountant Plus	\$ 95
1st Class Mail	\$ 79
Computer Software Technology	
Word/PC	\$ 49
Davidson & Associates	
Speed Reader	\$ 49
Datamost	
Real Estate Investment Program	\$ 79
Write-On	\$ 85
Comprehensive Software	
PC Tutor	\$ 55
Eagle Software	
Money Decisions	\$129
Howard Software	
Real Estate Analyzer II	\$159
Tax Preparer 1983	\$159
Innovative Software	
T.I.M. III	\$299
IUS	
Easy Filer	\$249
Easy Writer II	\$219
Easy Planner	\$159
Accounts Receivable	\$369
Accounts Payable	\$369
General Ledger	\$369
Financial Management Series	\$899
Micro Lab	
The Tax Manager	\$159
Micro Pro	
Wordstar 3.3	\$299
Mailmerge 3.3	\$159
Spellstar 3.3	\$159
Infostar 3.3	\$299
Reportstar 3.3	\$209
North American Business Systems	
Answer	\$159
PBL Corporation	
Personal Investor	\$ 89
Peachtree	
General Ledger	\$229
Accounts Receivable	\$229
Accounts Payable	\$229
Peach Pak (GL/AR/AP)	\$229
Software Publishing	
PFS Report	\$ 85
PFS File	\$ 95
Digital Research	
Concurrent CP/M	\$209
C Basic 86	\$125
Pascal/MT + 86	\$239
Speed Programming Package 86	\$125
CIS Cobol 86	\$489
Peter Norton Computing	
Norton Utilities	\$ 55
Select	
Select Word Processing System	\$299
Softword Systems	
Multimate	\$289
Sorcim/ISA	
Supercalc	\$125
Superwriter	\$125
Spellguard	\$125
Southeastern	
Data Capture	\$ 75
Visicorp	
Visicalc (256K)	\$165
Desktop Plan 1	\$199
Visitrend/Plot	\$199
Visifile	\$199
Visidex	\$165
Visischedule	\$199
Business Forecasting Model	\$ 89

IBM Personal Computer

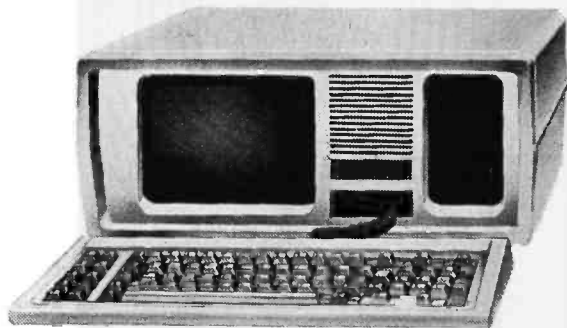

Includes 64K IBM-PC with two 320 KB floppy disk drives, color controller graphics card, monochrome monitor

\$2839

★★ Specials of the Month ★★

Verbatim Disks (S/D w/Library Case)	\$ 24
Box of Maxell Disks (D/D) w/color coded markers	\$ 40
Filp 'n File Diskette Box with Lock (Holds 25)	\$18.50
Elephant Disks Single Side/Double Density	\$ 24
Quadboard 256K Installed	\$ 399
Quad 512 + (512K Installed)	\$ 599
Mark VI Modem (w/Terminal Software)	\$ 179
AST Megaplus II (256K Installed)	\$ 539
Lemon Surge Protector	\$ 39
Orange Surge Protector	\$ 95
Corona Desktop Computer 2/320K Drives/128K	\$2595
Corona Desktop Computer 1/320 Floppy-1 10MG-128K	\$3995
Corona Desktop Portable Computer 2/320 Drives-128K	\$2545
Corona Portable Computer 1/320 DRives-10MG-128K	\$4295



1095 E. Twain, Park Place—Upper Level
(702) 796-0296, Las Vegas, Nevada 89109

Call Toll Free

1-800-634-6766

Order Line Only

Information & Order Inquiries (702) 369-5523
Mon. — Fri. 8 A.M. to 6 P.M., Sat. 9 A.M. to 5 P.M.
Dealers Inquiries Invited

Ordering Information and Terms: For Fast Delivery send cashier checks, money orders or direct bank wires. Personal and company checks allow 3 weeks to clear. C.O.D. orders (\$3.00 minimum) and 1% of all orders over \$300. School purchase orders welcomed. Prices reflect a cash discount and are subject to change. Please enclose your phone number with any orders. Shipping: Software (\$2.50 minimum). Shipping Hardward (please call). Foreign orders, APO and FPO orders—\$10 minimum and 15% of all orders over \$100. Nevada residents add 5 1/4% sales tax. All goods are new and include factory warranty. Due to our low prices, all sales are final. All returns must have a return authorization number. Call 702-369-5523 to obtain one before returning goods for replacement.

Monitors

Amdek	
Color II	\$ 879
Color III	\$ 399
Color IV (RGB Analog Input)	\$1029
USI	
Amber Monitor 12"	\$ 149
Leading Edge	
Gorilla Hi-Res 12"	\$ 85

Quadram Quadchrome

- Hi-Res RGB Monitor
- Non-Glare Screen
- 690 x 240 Resolution

\$549

Peripherals

Kraft Joystick	\$ 45
TG Joystick	\$ 39
TG Trackball	\$ 39
Microsoft 64K Ramcard	\$239
Microsoft 256K Ramcard	\$589
Hayes Smartmodem 300	\$209
Hayes Smartmodem 1200	\$499
Hayes Smartmodem 1200B	\$399
Hayes Smartcom II Terminal Pk.	\$ 72
Anchor Automation Mark VI Modem	\$179
Quadram Microfazer w/Power Supply	\$149
IBM Interface Card	\$ 45
Versawriter Graphics Tablet	\$239

Printers

NEC	
NEC 8023A	\$ 439
NEC 3530	\$1599
NEC 7710	\$2059
NEC 7730	\$2059
NEC 3550	\$1899

Diablo	
Diablo 620R (25CPS)	\$ 949
Diablo 630R (40CPS)	\$1729
Diablo 630KSR (40CPS)	\$2429

Epson	
FX80	\$ 599
FX100FT	\$ 799

Smith Corona	
TP-1 Parallel	\$ 499

Okidata	
ML82A	\$ 419
ML83A	\$ 649
ML84P	\$ 979
ML84S	\$1089
ML92	\$ 489
ML93	\$ 869

IDS	
Microprism 80	\$ 549
Prism 132	\$1399
(with Sheetfeed & Graphics)	\$1589
Prism 132	(with Sheetfeed, Graphics & Color)
Prism to IBM Cable	\$ 48

Citoh	
8510 Prowriter	\$ 365
F10 Starwriter	\$1199
F10 Printmaster	\$1599

Mannesmann Tally	
MT 160L	\$ 599
MT 1802 (Parallel)	\$1559
MT 1805 (Serial)	\$1559

Gemini	
Gemini 10	\$ 319
Gemini 10x	\$ 319
Gemini 15	\$ 479

Qume	
Qume Sprint 11 +	\$1349
Tractor Feed	\$ 175
Printer Interface	\$ 79



LC NETWORK LINE FILTER

Model C-519-L1 EMI/RFI filter protects against high energy transients... varistor clamps higher voltages to safe levels... Max Rating: 15 A, 125 VAC, 1875 Watts continuous duty... \$97.50.

J. W. MILLER
DIVISION/Bell Industries
19070 Reyes Ave., Rancho
Dominguez, CA 90224
(213) 537-5200

Circle 312 on inquiry card.

SEND FOR OUR FREE

1983 PARTS CATALOG
THOUSANDS OF SURPLUS
ELECTRONIC PARTS,
SUPPLIES AND DEVICES.

ALL ELECTRONICS CORP.
905 S. Vermont Ave.
P.O. Box 20406
Los Angeles, Cal. 90006

Circle 26 on inquiry card.

\$\$\$ Printers \$\$\$

\$\$\$ WE WILL NOT BE UNDERSOLD \$\$\$

EPSON
RX 80, MX 80FT, MX 100FT, FX 80 & newest
FX 100 "lowest prices in the USA"

Gemini 10X.....	\$329
Gemini 15.....	494
Prowriter 8510 (P).....	385

All other printers discounted

Miscellaneous Hardware

Microsoft Premium Pack.....	479
Microsoft Softcard.....	239
Microsoft Softcard Plus.....	489
(Includes videx 80 Col.)	
Smartterm 80 Col.....	145
Wizard 80 Col.....	179
Videx 80 Col. Combo.....	257

Printer Cards

Parallel.....	69
Wizard Buffered BPO.....	149
Grappler +.....	125
Buffered Grappler +.....	209

THE COMPUTER STORE
3941-B S. Bristol Street
Dept. 345
Santa Ana, CA 92704
714-261-1383
ORDERS ONLY: (800) 824-2227

Circle 116 on Inquiry card.

SUPER-FAST!
Z80
Relocating Macro
ASSEMBLER
\$169.95

Directly generates COM, HEX, or REL files. Flexible REL format allows external bytes and words with complete math operations on them (Microsoft format optional). Features Zilog mnemonics with nested macros, conditionals and include files. Unique one-pass design generates compact intermediate code which is then processed to resolve forward references, yielding tremendous time savings. Complete listing, symbol table and cross-reference output may be sent to any device. The perfect tool for assembly language programming. Linker included. Manual only — \$30. For Z80 CP/M and TRS-80

S L R Systems
1622 NORTH MAIN ST. • BUTLER, PA 16001 • (412) 282-0864

Shipping \$12.00. Outside U.S. Add \$10.00. VISA/MC/C.O.D. (13)
E-mail format available. Excess and OEM inquiries invited.
Z80 CP/M THIS IS THE ONLY Zilog Digital Research Study Group.

Circle 427 on inquiry card.

TeleVideo DEALERS

- Fast Dump/Restore over 800k per disk \$60
- Type Ahead with Print Screen
- 64 Character Type Ahead Buffer \$60
- 3270 & 2780/3780 Bisync Communications from Phone 1 & Batech \$700 & \$300
- TurboDOS for TeleVideo..... Start at \$225
- BIOS & Formatting for 802H use all 20 MB \$150
- 8" Disk Drive for 802 Computer Drive & Software..... \$1,100
- RM Cobol™ for TurboDOS Full System..... \$525
Run Time..... \$175
- Standby Power System 200VA-400VA-800VA..... As low as \$363

RM/COBOL is a registered trademark of Ryan-McFarland Corp.
CP/M® is registered trademark of Digital Research, Inc.
TurboDOS is a registered trademark of Software 2000, Inc.

PLUS OTHER GOOD TELEVIDEO STUFF!

COGITATE, Inc.
SPECIALISTS IN UNIQUE TELEVIDEO SOFTWARE
24000 Telegraph Road, Southfield, MI 48034
(313) 352-2345
VISA/MASTER CARD Accepted

Circle 86 on inquiry card.

THE BURNER I/O
\$100/IEEE 696

Has a complete EPROM programmer, two serial ports, one parallel I/O port with handshaking and memory management.

Programmer features: • Programs 2704, 2708, 2508, 2758, 2716, 2516, TMS2716, 2732, 2732A, 2764 • CP/M compatible software supplied in EPROM that can be easily written on a diskette. EPROM selection is done with software. Does not use programming modules • Programmer is totally I/O mapped • Programming socket is zero insertion force type • Programming voltages generated on board.

I/O Features: • 2 fully independent RS-232 serial ports • Baud rate Generators are independently programmable from 50 to 19200 baud • Independent 8 bit output, input and status flags • 4 direct sense lines

Memory management features: • Controls address lines A16-A23 • Is disabled with standard ADSB signal.

Options: • Complete board with programmer, I/O and memory management, \$354.95 • Programmer only, \$219.95 • I/O only (2S + P) \$219.95 • Prog and I/O, \$329.95 • Memory management only \$109.95

Memory management may be added to programmer or I/O for \$25.00. All combinations are assembled and tested. Delivery Stock Shipping: UPS surface \$3.00, UPS air \$5.00

EXTENDED PROCESSING
3861 Woodcreek Lane, San Jose, Ca. 95117
(408) 249-8248

Circle 181 on inquiry card.

6809
Single Board Computer

6809 MPU, 2 serial ports, 4 parallel ports, RAM, EPROM, real-time clock, watchdog timer, 44-pin 4.5" x 6.5" PCB

EXPANSION MODULES: RAM, EPROM, CMOS RAM/battery, analog I/O, serial I/O, parallel I/O, counter/timer, IEEE-488, EPROM programmer, floppy disks, cassette, breadboard, keyboard/display.

WINTEK
Wintek Corp.
4801 South Street
Lafayette, IN 47904
317-742-8428

Circle 512 on inquiry card.

SAVE 50%
on
maxell®
DISKETTES

Dealer Inquiries Invited

5 1/4" Specify Soft
10 or 16 Sector prices/10

MD1-MH1 1 side/dbl dens.....	\$27.90
MD2-MH2 2 side/dbl dens.....	\$40.00
MD1-DDM 1 side/quad 96 tpl.....	\$36.50
MD2-DDM 2 sides/quad 96 tpl.....	\$45.50

8" Specify Soft or 32 Sector

FD1-FH1 1 side/sgl or dbl dens....	\$38.90
FD2-FH2 2 sides/dbl den.....	\$45.50

Checks-VISA-MC-C.O.D./Add \$2 Shipping
Call or write for our discount catalog.

LYBEN COMPUTER SYSTEMS
27204 Harper Ave., St. Clair Shores, MI 48081
Phone: (313) 777-7780

Maxell. The Gold Standard.

Circle 278 on inquiry card.

SUPER PRICES --
SUPER MICROS

SAGE
COMPUTER TECHNOLOGY

SAGE IV computers use the 68000 CPU, come with UCSD p-System, PASCAL, Macro Assembler, Multi-user system, Word processor, Spreadsheet, 1 year warranty.

Available SAGE configurations include:

1 640K floppy & 256K RAM	\$3120
2 640K floppies & 256K RAM	\$3760
1 floppy, 256K RAM, 6mb Hard disk	\$5840
1 floppy, 1mb RAM, 18mb Hard disk	\$8000

As software developers and authorized SAGE dealers we offer customer support.

MARITIME SOFTWARE ASSOCIATES
(503) 929-2552
6660 Reservoir Road, Corvallis, OR 97333

Circle 287 on inquiry card.

DISPLAYED VIDEO IS DRIVING DOWN PRICES ON DISKS! FREE SHIPPING!

DV'S EXCLUSIVE "YOU CANT LOSE" SIX MONTH WARRANTY!

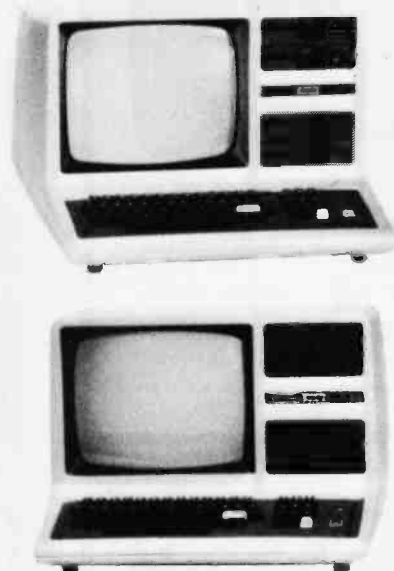
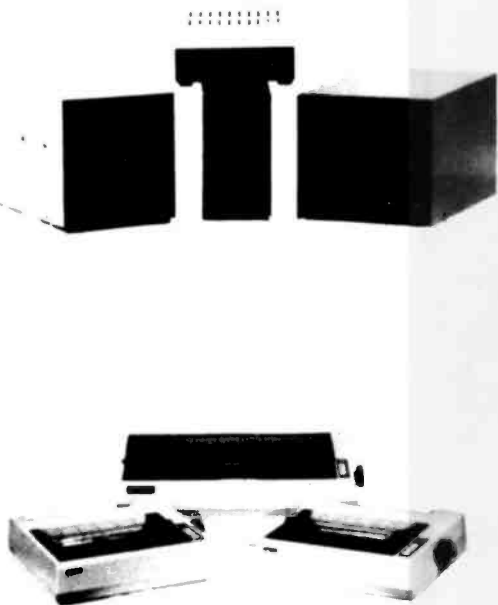

TEC'S NEW HALF-HIGH 40 TRACK DISK DRIVE W/CASE & POWER SUPPLY AT AN INCREDIBLE LOW PRICE! \$195.00!!!!

NEW! TRUE HALF HEIGHT DRIVES! 1 5/8 INCH NOT 2 INCH OR 2 7/16 INCH! DIRECT DRIVE! NO DRIVE BELT! 3MS TRACK TO TRACK!

- TEC's New Slimline 40 Track w/case & power supply..... **\$235.00**
- Tandon 40 Track TM-100-1 w/case & power supply..... **\$220.00**
(DOUBLE SIDED 40 TRACK DRIVES ADD \$75.00)
- Shugart New Slimline Double Sided 40 Track w/case & P.S..... **\$299.00**
- Shugart New Slimline Double Sided 80 Track w/case & P.S..... **\$379.00**
- Tandon Single Sided Slimline 8" Disk Drive w/dual case & P.S.... **\$545.00**
- Tandon Double Sided Slimline 8" Disk Drive w/dual case & P.S.... **\$625.00**
- Two Drive 5 1/4" Cable (FOR MOST COMPUTERS)..... **\$23.99**
(WITH GOLD PLATED CONNECTORS)
- DV's Color Computer 1st Drive Only..... **\$389.00**
- ONE YEAR WARRANTY ON TEAC & SHUGART DRIVES/180 DAYS ON TEC & TANDON
- Hayes Smart Modem 300 Baud..... **\$225.00** 1200 Baud..... **\$525.00**
- Model I Double Density Board..... **\$89.00**
- DV's Line Filter W/Surge Supression..... **\$45.00**
- Diskette File Box "Holds 70 Diskettes"..... **\$29.95**

PRINTER PRICES

- FX80 FT w/Graphtrax Plus. **\$459.00** Gemini 10..... **\$349.00**
- FX100 w/Graphtrax Plus. **\$659.00** Gemini 15..... **\$479.00**
- FX80 w/Graphtrax Plus... **\$389.00** Citech Prowriter 8510..... **\$395.00**
- FX80 w/Graphtrax Plus... **\$569.00** Starwriter F10..... **\$1169.00**
- FX100 w/Graphtrax Plus... **\$779.00** Smith Corona TP1..... **\$595.00**
- Printer Cable 10' long w/gold plated connectors starting at..... **\$25.99**

"NO YOU'RE NOT SEEING THINGS, THAT'S FOUR INTERNAL DRIVES IN A MODEL 4, WITH UP TO 4 MEG, DISK STORAGE AVAILABLE NOW!"

DV IS DRIVING DOWN PRICES ON DISK!

DISPLAYED VIDEO is now offering TRS-80' MODEL 4 with TANDON/TEC/TEAC disk drives, one of the most reliable disk drive systems on the market, for **INCREDIBLY** low prices.

- MODEL 4 with 64K dual 40 track double density disk drives, complete system with TRSDOS 6.0 and 1 BOX OF DISKETTES
PLUG IT IN AND GO..... \$1599.00/128K...\$1679.00
- MODEL 4 with 64K dual 40/40 track double density disk drives, complete systems with TRSDOS 6.0 and 1 BOX OF DISKETTES
PLUG IT IN AND GO..... \$1899.00/128K...\$1979.00
- MODEL 4 with 64K dual 80 track double density disk drives, complete systems with TRSDOS 6.0 and 1 BOX OF DISKETTES
PLUG IT IN AND GO..... \$1899.00/128K...\$1979.00
- MODEL 4 with 64K dual 80/80 track double density disk drives, complete systems with TRSDOS 6.0 and 1 BOX OF DISKETTES
PLUG IT IN AND GO..... \$2199.00/128K...\$2279.00
- MODEL 4 with 64K four 40 track double density internal disk drives, complete systems with TRSDOS 6.0 and 1 BOX OF DISKETTES
PLUG IT IN AND GO..... \$2299.00/128K...\$2379.00
- MODEL 4 with 64K four internal drives of any configuration available to achieve up to 4 meg of disk storage..... **CALL**
- MODEL III/4 Internal Two Drive Kit: Includes controller board, dual drive mounting bracket, dual power supply, all hardware cable, and connectors (gold plated) & TEC Drive..... **\$399.00**
- 4 DRIVE KIT MINUS DRIVE..... **\$349.00**
- MODEL 100 8K..... **\$679.00** 24K..... **\$839.00**
- DV'S MODEL I DOUBLE DENSITY BOARDS..... **\$89.00**

WE CARRY TRS-80, IBM, LNW, EPSON & FRANKLIN COMPUTERS

Visit our retail location at:
**111 Marshall Street
Litchfield, MI 49252**
(313) 426-5086
(313) 482-4424
(517) 542-3280
(517) 542-3939
(517) 542-3947

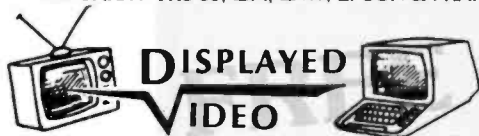

**IMMEDIATE DELIVERY
DV'S SIX MONTH
PARTS AND LABOR WARRANTY**

Authorized Dealership at:
111 Marshall Street, Litchfield, Michigan 49252 P142
To Order: Call (313) 426-5086; (313) 482-4424; (517) 542-3280
(517) 542-3939; (517) 542-3947
OR WRITE:

Displayed Video, 111 Marshall St., Litchfield, MI 49252

Circle 157 on inquiry card.

*TRS-80 is a trademark of the Tandy Corporation

Prices subject to change without notice.

When it comes to quality software for microsystems, DYNACOMP delivers:

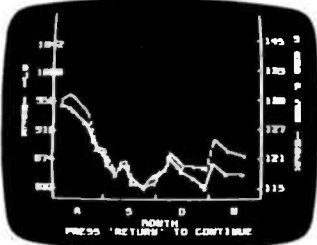

STOCK MASTER (APPLE): \$59.95
 The Systems ... Apple Atari Canon Commodore
 ComStar CP/M Franklin H/Z-100
 IBM PC Kaypro Morrow NEC North Star
 Osborne SuperBrain Timex TRS-80

The Software ...

ADVENTURE BUSINESS CARD GAMES HOME FINANCE EDUCATION
 ENGINEERING GAMES INVESTING
 LANGUAGES SCIENCE TAX PLANNING UTILITIES

Name brand diskette: \$19.95/10 (SS, SD w/hub ring).
 Includes FREE plastic storage box. Add \$2.00 shipping.
 CALL OR WRITE FOR A FREE CATALOG
 DYNACOMP, INC.
 1427 Monroe Avenue, Rochester, N.Y. 14618
 Telephone: (716) 442-8960

Circle 163 on inquiry card.

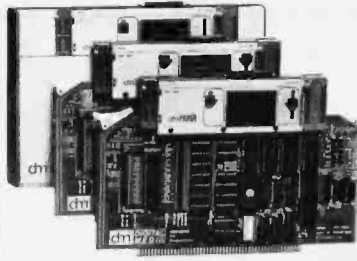

NEW GENERATION OF INTELLIGENT PAL/EPROM PROGRAMMERS - FOR THE NEW BREED OF ENGINEERS

• 20 AND 24 PIN PALs • 27 AND 25 EPROMs • ROM EMULATION

DIGITAL MEDIA
 3178 GIBRALTAR AVENUE
 COSTA MESA, CA 92626
 (714) 751-1373

Circle 152 on inquiry card.

5 Year Warranty
SAVE 50% ON
 Verbatim Datalife
 Diskettes

DEALER INQUIRIES INVITED

5 1/4" Specify Soft 10 or 16 Sectors prices/10
 MD525 1 side/dbl dens \$24.90
 MD550 2 sides/dbl dens 35.00
 MD577 1 side/quad 96tpf 33.75
 MD557 2 sides/quad 96tpf 44.50

8" Specify Soft or 32 Sector
 FD34-9000 1 side/sgl dens 30.00
 FD34-8000 1 side/dbl dens 33.00
 DD34-4001 2 sides/dbl dens 41.00

Checks-VISA-MC-C.O.D./Add \$2 Shipping
 Call or write for our discount catalog.

LYBEN COMPUTER SYSTEMS
 27204 Harper Ave., St. Clair Shores, MI 48081
 Phone: (313) 777-7780

**DATALIFE • THE NAME IS THE PROMISE
 THE WARRANTY IS THE PROOF**

Circle 279 on inquiry card.

wabash®

When it comes to Flexible Disks, nobody does it better than Wabash.

MasterCard. Visa Accepted.
 Call Free: (800) 235-4137



PACIFIC EXCHANGES
 100 Foothill Blvd.
 San Luis Obispo, CA
 93401 (In Cal call
 (805) 543-1037)

Circle 341 on inquiry card.



**PC-LINK
 DEC VT100® TERMINAL
 EMULATOR**

- A full featured DEC VT100® terminal emulator on IBM PC/XT.
- Transfer text files between host and IBM PC/XT.
- Very easy to use. Complete user documentation.
- To use PC-LINK program, the PC needs to have at least one disk drive, IBM DOS IBM monochrome or color display, a RS232 port, telephone modem or direct connect.
- Support baud rate up to 1200 baud.
- \$60.00 + \$5.00 for shipping & handling.

SCREENWARE CORPORATION
 P.O. BOX 3662
 NASHUA, NH 03061-3662
 Tel. 603-888-4074



IBM, IBMPC and trademarks of IBM Corpor-
 ation, Digital DEC, VT100 are trademarks of
 Digital Equipment Corporation.



Circle 414 on inquiry card.

HEXADECIMAL DESK CLOCK



Solid mahogany timepiece represents the time in base sixteen. Features include: handrubbed finish, gold tone characters and hands, and a quartz movement accurate to within 10 seconds per month. Clock measures 4 1/2 in. square, can be hung (bracket included), and runs for over 1 year on a standard AA battery. An attractive addition to the work area of any computer professional or hobbyist.

Only \$18.95 plus \$1.50 shipping & handling.
 PA residents add 6% sales tax.
 Please allow 3-5 weeks for delivery.
 Send check or money order to:

DIGITIME
 P.O. Box 403, Ambler, PA 19002

Circle 154 on inquiry card.

YOUR NAME HERE

**PERSONALIZED
 COMPUTER PAPER**

Printed with your name, club, anything. Paper is white 20# stock and fits all printers using 9 1/2 x 11 continuous paper (8 1/2 x 11 when detached).
500 sheets \$14.95, 1000 sheets \$24.95. We pay shipping. Texas orders add 5 1/2% tax. Select ink color: red, blue, brown, gray, or canary. Specify name(s) up to 30 letters & spaces. Enclose check or money order. No CDD's. Allow 3 weeks. Faster delivery with M/C, Visa phone orders. Write or phone **Personalized Computer Paper B**, Box 20539/San Antonio, Tx. 78220/ (512) 227-0585.

Circle 375 on inquiry card.

CHIPS & DALE

THE INFLATION FIGHTERS!

- 4116 250ns 8/\$9.50 100+ 1.05 ea.
- 4116 200ns 8/\$10.00 100+ 1.05 ea.
- 4116 150ns 8/\$11.50 100+ 1.25 ea.
- 4116 120ns 8/\$14.50 100+ 1.50 ea.
- 4116 120ns 8/\$15.50 100+ 1.50 ea.
- 2114L 300ns 8/\$10.50
- 2114L 200ns 8/\$12.00
- *4164 200ns 8/\$4.65 ea.
- *4164 150ns 5/\$5.10 ea.
- *6116 150ns 5/\$4.00 ea.
- *6116 200ns 5/\$3.95 ea.
- *6116LP 150ns 44.75 ea.
- *1791 Disk Controller \$20.00
- 1777 Disk Controller \$17.50
- Z80A, Z80ACTC, Z80A PIO \$3.00 ea.
- 8255 \$4.25
- 2716-1 5V 350ns 8/\$4.25 ea. \$5.00 ea.
- 2716 5V 450ns \$3.00 ea.
- *2732 5V 450ns \$3.85 ea.
- *2532 5V 450ns \$4.25 ea.
- *2764 5V 300ns 28 pin \$9.00 ea.
- *2764 5V 24 pin CALL
- *2564 5V CALL
- *8087 CALL
- 68000 CALL

Allow up to 3 wks. for personal checks to clear. Please include phone number. Prices subject to change without notice. Shipping & Handling for Chips \$3.50, FOB Bellevue, WA. For all else, Wash. residents add 6.5% Sales Tax.

CHIPS & DALE 1-206-451-9770
 10655 N.E. 4th St., Suite 400
 Bellevue, WA 98004

Circle 82 on inquiry card.

**CP/M CROSS
 SOFTWARE
 for the NS16000**

INCLUDES:

- ★ Cross Assembler ★
- ★ Cross Linker ★
- ★ Debugger ★
- ★ Librarian ★
- ★ Pascal Cross Compiler ★

Prices start at \$500 for Assembler only.

**SOLUTIONWARE
 CORPORATION**

1283 Mt. View-Alviso Rd.
 Suite B
 Sunnyvale, CA 94086
 408/745-7818

Circle 438 on inquiry card.

**IBM PC 256K
2X 320 KB DS/DD DISK DRIVES
FLOPPY DISK CONTROLLER
COLOR CARD
ALL FOR \$2599**

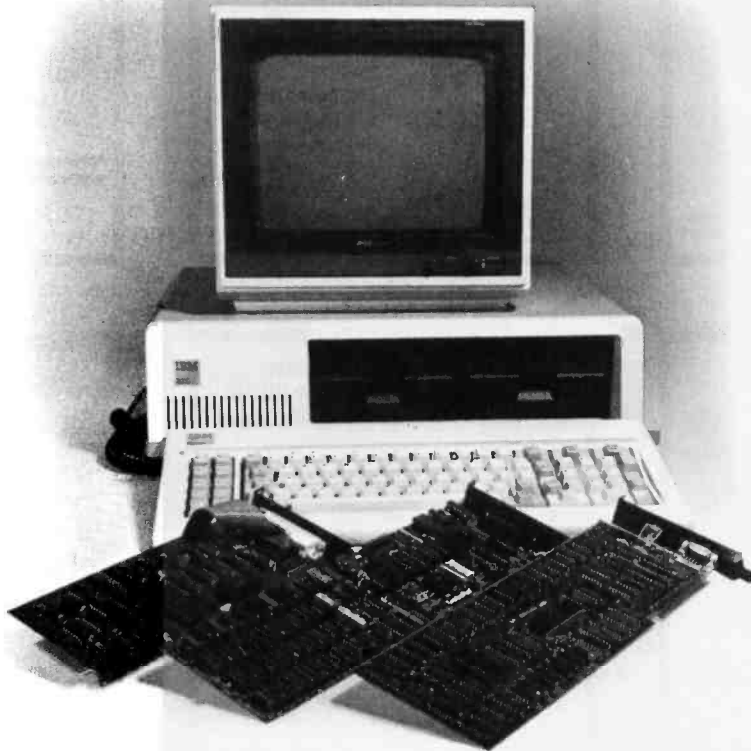

**VISICALC \$199
MULTIPLAN \$199**

**LOTUS 1-2-3 \$359
SUPER CALC II \$199**

**IBM PC256K COLOR GRAPHICS BOARD FLOPPY DRIVE CONTROLLER
WITH PARALLEL PORT 360KB DS/DD DISK DRIVE, PRINTER, CABLE
DOS 2.0, 10MB HARD DISK SUBSYSTEM INCLUDES CABLE,
CONTROLLER, POWER SUPPLY, CABINET, SOFTWARE
ALL FOR \$4295.**

**WORDSTAR \$329 WORD PERFECT \$349
MAILMERGE \$179 EASY WRITER \$129**

**DISK DRIVES FOR IBM PC
DOUBLE SIDED DOUBLE DENSITY
320 KB \$225**

**PGS COLOR MONITOR
HX-12 \$499
AMDEK, NEC MONITORS AVAILABLE**

**DRIVE FOR APPLE II+ and IIe
ONLY \$219**

PRINTERS

**BROTHER HR-1 \$750 BROTHER HR-15 \$499
OKIDATA 82A \$499 83A \$699 84A \$999
 93A \$959
GEMINI-10 \$359 GEMINI-15 \$529
NEC 3510 \$1399 3550 \$1799
 7710 \$1975
EPSON RX80 \$379 FX80 \$599
MX80/FT \$449 MX100 \$649**

**MEMORY BOARDS
AST COMBO CARD 64K
MULTIFUNCTION \$299 I/O PLUS \$199
QUADRAM 256K MULTIFUNCTION \$399
HERCULES CARD \$499
QCS BIG BLUE CARD \$479**

**APPLE IIe STARTER SYSTEM
\$1599**

**HARD DISK FOR IBM PC
5MB \$1399 10MB \$1599 15MB \$2199**

**HAYES
SMARTMODEM 300 \$239
SMARTMODEM 1200 \$559
KAYPRO DEC DIABLO DAVONG
MAYNARD LNW TAXAN BMC
C ITOH EPD TELEVIDEO TANDON
MPI SHUGART
AND MUCH MORE AVAILABLE!
CALL!**

SEND ORDERS AND INQUIRES TO:
COMPUTER POST INC.
22102 CLARENDON ST. STE. #1
WOODLAND HILLS, CA 91367
(213) 999-1041

DELIVERIES TWO TO FOUR WEEKS AVERAGE
ALL SHIPMENTS ARE CASHIERS CHECK ONLY.
PRICES SUBJECT TO CHAGE WITHOUT NOTICE.
SHIPPING AND HANDLING EXTRA

COMPUTER RUNS MOTORS



- ROBOTS
- PROCESS CONTROL
- CONVEYORS
- ONE PORT RUNS UP TO FOUR MOTORS

Use your computer with the CDFR controller to command speed and direction of two independent motors from a single output port. For robot drive motors or any two functions requiring proportional bipolar control of 15 Vdc up to 12 Amps each. Normally the controller installs between the computer, a 12 Vdc battery, and two DC PM motors mounted right and left on a robot. Simple software commands set speed and direction latches in the CDFR thus freeing your computer for other tasks. Two CDFRs control four motors with a single port. The CDFR speed control uses CMOS, optoisolators & relayless PWM power circuitry. One year limited warranty. Buy now with parallel interface for \$225.00, or serial for \$315.00. Other robotics components available. MC, VISA, MO, or check.

VANTEC

15445 VENTURA BLVD., SUITE 10-281
SHERMAN OAKS, CA 91413
(213) 993-1073



Circle 493 on inquiry card.

MEMOREX FLEXIBLE DISCS

WE WILL NOT BE UNDER-SOLD!! Call Free (800)235-4137 for prices and information. Dealer inquiries invited and C.O.D.'s accepted.

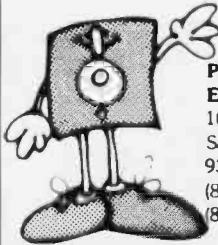

PACIFIC EXCHANGES
100 Foothill Blvd.
San Luis Obispo, CA
93401. In Cal call
(800)592-5935 or
(805)543-1037

Circle 341 on Inquiry card.

CompuPro SYSTEMS

All systems configured, assembled and tested.
Full service dealer.

- SYSTEM 816/A \$4260.
128K, Retail \$5495
- SYSTEM 816/B \$5150.
256K, Retail \$6995
- SYSTEM 816/C \$6660.
384K, MP/M 8-16, Retail \$8995

MORROW MICRO DECISION™
MD1 \$843. MD2 \$1148. MD3 \$1670
(terminal \$500 additional)

Call for deep discounts on boards/drives.
Located in Northern Virginia

ONETCO

OFFICE NETWORKS CORPORATION

(703) 690-3312

Authorized CompuPro and Morrow Dealer.

Circle 333 on inquiry card.

AUTHORS

CompuSoft® Publishing is now considering manuscripts for the 1984 season. If you have written or are working on a book-length project of the caliber of *Learning IBM BASIC*, or *Learning TIMEX/Sinclair BASIC* by David A. Lien, and you would like us to consider it for publication, send at least three sample chapters, a table of contents and a letter describing the book and your credentials, along with a self-addressed, stamped return envelope.

We are interested in well organized, easy to understand how-to books with wide popular appeal.

Write:

Editorial Director
CompuSoft® Publishing
535 Broadway, El Cajon, CA 92021



COMPUFT®
PUBLISHING

A DIVISION OF COMPUFT, INC. SAN DIEGO

NEW! NEW! NEW!
SPOOL-Z-Q 100

256K S-100 PRINTER BUFFER

If you use an S-100 computer, then SPOOL-Z-Q 100 can save you time (the time you waste waiting for your printer to finish) in a big way, because SPOOL-Z-Q 100 is the BIG buffer!

SPOOL-Z-Q 100 interfaces to both serial (RS-232) and parallel (Centronics standard) printers. All sizes are expandable to 256K. Standard serial protocols (XON/XOFF, ETX/ACK, ENQ/ACK, and both polarities of Reverse Channel) are supported at baud rates from 150 to 19,200. Many many more features. Call or write for more information.

PRICES: (Including shipping)
32K - \$319 64K - \$349
128K - \$409 192K - \$469
256K - \$529

15 DAY TRIAL PERIOD!

Call, Res. Addl 6% tax. We accept MC, VISA, AMEX, and COO (no extra charge) orders.

JVB ELECTRONICS
1601 Fulton Ave., Suite 10A
Sacramento, CA 95825
Phone: (916) 483-0709

DEALERS WANTED!

Circle 251 on inquiry card.

Poor Person Software Quality Software at Low Prices

Poor Person's Spread Sheet \$29.95

A programmable Calculator is combined with a Screen Design System to yield a powerful spread sheet substitute. Supplied Applications Include Real Estate Investment, Check Book Balance, and more.

Poor Person's Spooler \$39.95

Simultaneously prints files from disk and writes printer output to disk. Transparent to programs. All the function of a hardware buffer at a fraction of the cost.

Poor Person's Spelling Checker \$29.95

Includes 33,000 word dictionary compacted to 74k disk space.

aMAZEing Game \$29.95

ARCADE action for CP/M. Collect treasures and avoid goblins.

Window System \$19.95

Divides console screen into application controlled windows.

Spread Sheet and aMAZEing game require 56k CP/M and 80 x 24 video terminal with cursor functions. Window System requires direct cursor addressing and minimal assemble language programming. 8" IBM SD and Northstar DD. California Residents add sales tax.

Alan Bomberger

Poor Person Software, 3721 Sierr King Circle, Palo Alto, CA 94306

CP/M is a trademark of Digital Research Corp.

Circle 370 on inquiry card.

DataStar™ and your Fortran

HAVE THE BEST OF BOTH WORLDS—DataStar's powerful data input, sorting, and editing, and your Fortran programs to perform sophisticated data processing. With DSUBS, simple subroutine calls are all that are needed to read, write, and update DataStar data and index files.

SUPER DEAL: UTILITY package that includes numerous string processing, terminal control, CP/M BDOS and BIOS calls, character and number I/O, etc., and the DSUBS package, along with programming examples and thorough documentation, all for \$99.

Random Access, Inc.

P.O. Box 2094

Bloomington, IN 47402

(812) 339-5854



DataStar is a trademark of MicroPro Int.
CP/M is a trademark of Digital Research.

Circle 396 on inquiry card.

TOP QUALITY DISKETTES at ABSOLUTE LOWEST PRICES



- 2 YEAR WARRANTY
- DOUBLE SIDED
- DOUBLE DENSITY
- WITH HUB RING

\$1.95*
SOFT 10 OR
16 SECTOR

5 1/4" IBM Certified - \$2.49*

5 1/4" SSSD - \$1.75*

Minimum order - 10 diskettes

I-box complete with Tyvek sleeves & labels!

- Packed maximum of 10 boxes/case
- Quantity discounts:
100 deduct 5%, 1000 deduct 7%, 5000 deduct 10%
- Add \$4 per case 5 1/4", \$6 per case 8" (case of 100)
- For shipping/handling, Continental U.S.A. - UPS ground
- Checks require 10 day bank clearance
- Immediate shipment for C.O.D. Money Orders or Certified Checks
- Written purchase orders accepted from well-rated firms (15 day Net)
- Illinois residents add 6% sales tax
- Satisfaction guaranteed or purchase price refunded

Phone: (312) 367-5015

write: COMPUTER CONNECTION

a division of H & H Software, Inc.

310 Alexandria Dr. • Vernon Hills, IL 60061

INCLUDE \$50. FOR OUR COMPLETE

DISCOUNT SOFTWARE & HARDWARE CATALOGUE

Circle 105 on inquiry card.

BACT-186 MULTIBUS* SINGLE BOARD COMPUTER

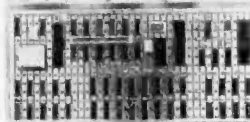

- IAPX-186 High Integration 16-bit microprocessor
- Twice the performance of the standard 8086 processor
- 128k byte of Dynamic RAM
- Sockets for up to 32k byte of PROM
- Two high speed DMA channels
- Three programmable 16-bit timers
- 14 internal vectored interrupts
- 4 external vectored interrupts
- High speed SDLC local network interface, 848,000 baud
- Three RS-232 programmable baud rate channels
- iSBX Multimodule expansion connector
- Multibus* compliance level: Master D16-M28-116-V#L
- *Multibus, iSBX are trade marks of the Intel Corporation.

\$850.00
Quantities
of 100

autocontrol

INCORPORATED
11400 Dorsett Rd.
Maryland Heights, MO 63043
(314) 739-0055

Circle 48 on inquiry card.

NEW LOWER PRICES

"THE ORIGINAL BIG BOARD"
 OEM - INDUSTRIAL - BUSINESS - SCIENTIFIC
SINGLE BOARD COMPUTER KIT!
Z-80 CPU! 64K RAM!
 (DO NOT CONFUSE WITH ANY OF OUR FLATTERING IMITATORS!)

NEW!

PARTIALLY ASSEMBLED KITS
 For All Sockets Installed
 And Soldered Add \$50.
 (Not For Blank PCB)

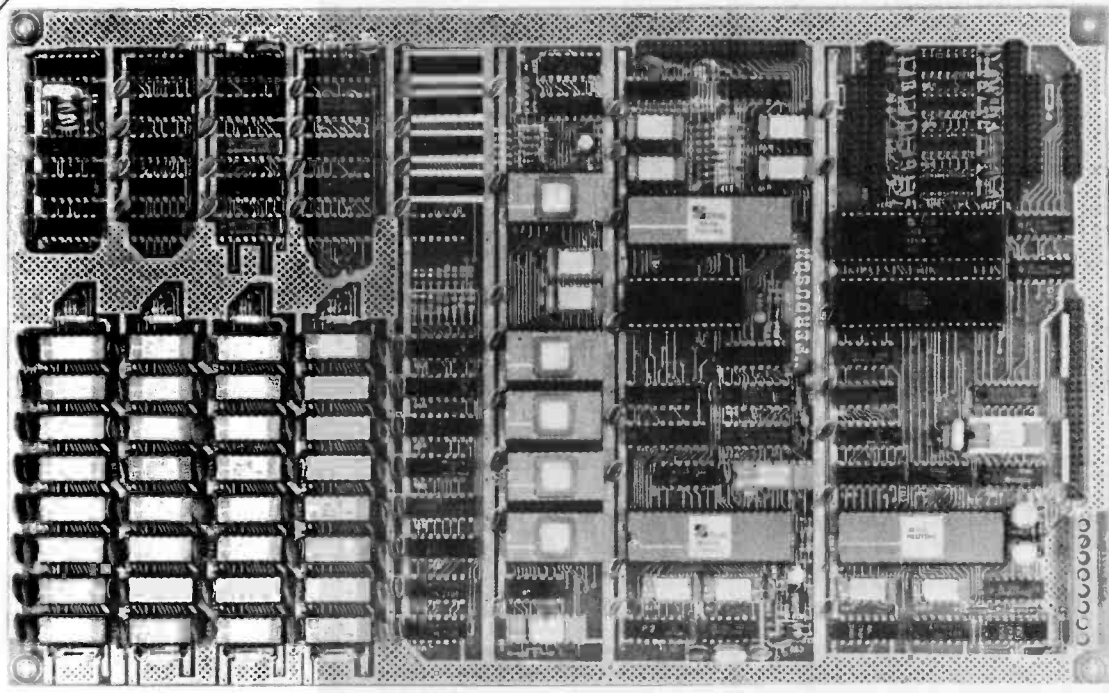

WANT MORE INFO?
 Full Documentation and
 Schematics — \$5.

THE BIG BOARD PROJECT: With thousands sold worldwide and over two years of field experience, the Big Board may just be one of the most reliable single board computers available today. This is the same design that was licensed by Xerox Corp. as the basis for their 820 computer.
 The Big Board gives you the right mix of most needed computing features all on one board. The Big Board was designed from scratch to run the latest version of CP/M*. Just imagine all the off-the-shelf software that can be run on the Big Board without any modifications needed.

\$279⁰⁰** (64K KIT BASIC I/O)

SIZE: 8 1/2 x 13 3/4 IN.
 SAME AS AN 8 IN. DRIVE.
 REQUIRES: +5V @ 3 AMPS
 + - 12V @ .5 AMPS.

FULLY SOCKETED! FEATURES: (Remember, all this on one board!)

64K RAM
 Uses industry standard 4116 RAM's. All 64K is available to the user, our VIDEO and EPROM sections do not make holes in system RAM. Also, very special care was taken in the RAM array PC layout to eliminate potential noise and glitches.

Z-80 CPU
 Running at 2.5 MHZ. Handles all 4116 RAM refresh and supports Mode 2 INTERRUPTS. Fully buffered and runs 8080 software.

SERIAL I/O (OPTIONAL)
 Full 2 channels using the Z80 SIO and the SMC 8116 Baud Rate Generator. FULL RS232! For synchronous or asynchronous communication. In synchronous mode, the clocks can be transmitted or received by a modem. Both channels can be set up for either data-communication or data-terminals. Supports mode 2Int. Price for all parts and connectors: \$39.95

BASIC I/O
 Consists of separate parallel port (Z80 PIO) for use with an ASCII encoded keyboard for input. Output would be on the 80 x 24 Video Display.

BLANK PC BOARD — \$99.95
 The blank Big Board PC Board comes complete with full documentation (including schematics), the character ROM, the PFM 3.3 MONITOR ROM, and a diskette with the source of our BIOS, BOOT, and PFM 3.3 MONITOR.

24 x 80 CHARACTER VIDEO
 With a crisp, flicker-free display that looks extremely sharp even on small monitors. Hardware scroll and full cursor control. Composite video or spill video and sync. Character set is supplied on a 2716 style ROM, making customized fonts easy. Sync pulses can be any desired length or polarity. Video may be inverted or true. 5 x 7 Matrix - Upper & Lower Case.

FLOPPY DISC CONTROLLER
 Uses WD1771 controller chip with a TTL Data Separator for enhanced reliability. IBM 3740 compatible. Supports up to four 8 inch disc drives. Directly compatible with standard Shugart drives such as the SA800 or SA801. Drives can be configured for remote AC off-on. Runs CP/M* 2.2.

TWO PORT PARALLEL I/O (OPTIONAL)
 Uses Z-80 PIO. Full 16 bits, fully buffered, bi-directional. Uses selectable hand shake polarity. Set of all parts and connectors for parallel I/O: \$19.95

REAL TIME CLOCK (OPTIONAL)
 Uses Z-80 CTC. Can be configured as a Counter on Real Time Clock. Set of all parts: \$9.95

CP/M* 2.2 FOR BIG BOARD
 The popular CP/M* D.O.S. to run on Big Board is available for \$139.00.

DOUBLE DENSITY ADAPTER BOARD — \$149.95 (A&T)
 Requires no cuts or MODS to an existing Big Board. Gives up to 670K storage on a single sided 8 in. diskette. With software to patch your CP/M* 2.2.

PFM 3.3 2K SYSTEM MONITOR
 The real power of the Big Board lies in its PFM 3.3 on board monitor. PFM commands include: Dump Memory, Boot CP/M*, Copy, Examine, Fill Memory, Test Memory, Go To, Read and Write I/O Ports, Disc Read (Drive, Track, Sector), and Search PFM occupies one of the four 2716 EPROM locations provided. Z-80 is a Trademark of Zilog.

Digital Research Computers
 (OF TEXAS)
 P.O. BOX 461565 • GARLAND, TEXAS 75046 • (214) 271-3538

TERMS: Shipments will be made approximately 3 to 6 weeks after we receive your order. VISA, MC, cash accepted. We will accept COD's (for the Big Board only) with a \$75 deposit. Balance UPS COD. Add \$4.00 shipping.
 USA AND CANADA ONLY

*TRADEMARK OF DIGITAL RESEARCH. NOT ASSOCIATED WITH DIGITAL RESEARCH OF CALIFORNIA, THE ORIGINATORS OF CPM SOFTWARE
 **1 TO 4 PIECE DOMESTIC USA PRICE.

THE DATA SAVER POWER SUPPLY



WITH
BATTERY
BACK-UP

FOR WINCHESTERS AND FLOPPY
COMPUTER SYSTEMS

Features: 4 Output Voltages

- +24V ± 10% 2.5A Regulated with battery charger
- +12V ± 1% 5A. Regulated
- +5V ± 1% 6A. Regulated
- -12V 0.2A
- 100KHZ Switcher
- Low Noise, Low Ripple
- OVP • OCP
- Continuous Battery Charging

Whole system can run 15 min. with battery only.
Mechanical Dimensions 1.5W x 4.625H x 8.6L

System Complete With:

- Power Supply w/Battery Charger
- 1 - 3 output Power Supply
- 2 Batteries

Single Output Supplies

- Also Available
- 1.5W x 4.625H x 8.6L
- +5V at 10A
- +12V at 10A
- +24V at 6A

Single Unit Price
\$480**
(OEM Pricing Available)

autocontrol
INCORPORATED
11400 Dorsett Rd.
Maryland Heights, MO 63043
1-314-739-0055

Circle 49 on inquiry card.

...If **DIRT** isn't part of your program ... **DecOtec™** has you covered

DecOtec™ decorator covers protects your equipment while offering a wide range of designs & colors to reflect your own personality or hobbies.

Not baggy generic covers - Tailored to fit your exact dimensions, standard or custom.

- Company logos
- Dozens of styles & colors available

DEALER INQUIRIES WELCOME

Write or call
for brochure today!

DECOTECH
(513) 236-9923
P.O. Box 24449 • Dept. B Dayton, Ohio 45424

Circle 145 on inquiry card.

BUSINESS SOFTWARE DATA COMMUNICATIONS

FOR IBM PC, SEATTLE, NEC COMPUTERS

Teleprocessing software available for above computers to time-sharing host or between two users (send binary files, also).

REMOTE DIAL-UP SYSTEM FOR ABOVE

NEW SEATTLE 8086 GAZELLE II

10 Mhz. - 256k mem.
Computer system.

US ROBOTICS modems. TELEVIDEO
Write for literature and prices on above systems, or call for quote.

CSCS
COMPUTER & STATISTICAL
CONSULTING SERVICES

P.O. Box 5351
Terre Haute, IN 47805
(812) 466-4111

Circle 128 on inquiry card.

Star Gemini 10X

\$269



120 CPS,
9x9 Dot
Matrix,
Graphics

- Amder 12" Monitor \$119
- Tandem Drive 100-2 320K for IBM \$235
- C. Itoh Prowriter 8510 120 cps \$339
- Dynax DX-15 Daisy Wheel 13 cps \$485
- Smith Corona TP-1 Daisy Wheel \$429
- Silver Reed EXP-550 Daisy Wheel \$649
- Brother HR-1 Daisy Wheel (16 cps) \$679
- Daisywriter 2000 (48K) \$1095
- Dume Sprint 11 Daisy Wheel 40 cps \$1395
- Eagle II Computer \$1595
- TeleVideo TeleTote I Computer Call
- Sanyo 555 IBM PC Compatible Call

MICRO MART

8764 Complex Dr., San Diego, CA 92123

(619) 268-0169

Circle 296 on inquiry card.

dy/dan **Dysan** CORPORATION

Solve your disc problems. buy 100% surface tested Dysan diskettes. All orders shipped from stock, within 24 hours. Call toll FREE (800) 235-4137 for prices and information. Visa and Master Card accepted.

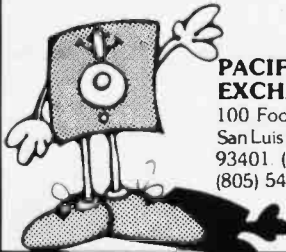

PACIFIC EXCHANGES
100 Foothill Blvd.
San Luis Obispo, CA
93401 (In Cal call
(805) 543-1037)

Circle 341 on inquiry card.

The Statistician

CPM IBM-PC TRS-DOS XENIX

- Multiple Regression Stepwise Ridge All Subsets Backward Elimination
- Time Series Analysis
- Descriptive Statistics
- Transformations
- Survey Research
- Nonparametrics
- XY Plots
- ANOVA
- Random Samples
- Data Base
- Search & sort
- Hypothesis tests

Please call TOLL FREE

1-800-334-0854 (Ext. 814)



for more information
or write:
Quant Systems
Box 628
Charleston, SC 29402
VISA/M/C Accepted

Circle 387 on inquiry card.

RIBBONS CARTRIDGES AND SPOOLS

	PRICE PER RIBBON	PRICE PER SPOOL
Anadex 9500	13.50	147.00
Commodore Pet 8023	7.00	81.00
C. Itoh Prowriter	5.95	68.40
C. Itoh Starwriter F-10	4.75	54.00
Data South DS-180	6.50	75.00
Epson MX-70/80	5.25	60.00
Epson MX-100	9.95	108.00
Epson MX-100 Reload	6.50	72.00
Gemini - 10	2.50	27.00
IDS Microprism - 480	6.00	69.00
IDS Paper Tiger 460/560	7.50	87.00
IDS Prism	8.00	93.00
Okidata - 80, 82 & 83	2.50	27.00
Okidata - 84	5.00	57.00

TO ORDER CALL (313) 569-3218 or
WRITE FOR OUR CATALOG

DWIGHT COMPANY, INC.
15565 NORTHLAND DRIVE
WEST TOWER SUITE 804
SOUTHFIELD, MICHIGAN 48075

Circle 161 on inquiry card.

\$300.00 8/16 Bit Fast Static Ram

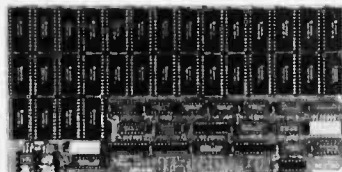

SR-64K RAM MODULE. 24 bit addressing. 5100/IEEE 696 compatible. (64K x 8) / (32K x 16). 10 MHz no wait states. Phantom option. upper 16K bytes deselectable in 2K byte blocks. 1 year warranty.

TERMS: We accept checks or money orders. Allow 3 weeks for personal checks to clear. Delivery is from stock to 6 weeks. Add \$5.00 per a board for shipping. MA residents add 5% sales tax.

LEXICOMP DATA SYSTEMS

P.O. BOX 222
LEXINGTON, MA 02173
TEL. (617) 862-3088

Circle 268 on inquiry card.

EXCLUSIVE - FREE MANUFACTURER'S WARRANTY

• Prices are the lowest available.

Model	Qty. 1	Qty. 2-10
FDD100-B	\$225	\$200
FDD200-B	\$275	\$250

*Additional quantity discounts available. With the FDD-200-B, you buy twice the storage capacity at a nominal cost increase.

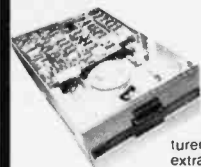

Shugart Compatible Drives

FDD100-B
FDD200-B

• No other company can offer the manufacturer's 90-day warranty at no extra charge.

- All warranty work is accomplished at the manufacturer's factory authorized service center.
- We ship from existing inventory.

Visa/Mastercharge

H&M Disk Drive Services

689 L South State College Blvd., Fullerton, CA 92631
(714) 526-1992/Call Collect. Mail Order: Add \$7 Shipping. California residents add 6% sales tax

Circle 201 on inquiry card.

7400

7400	19	74125	39
7401	22	74126	44
7402	22	74128	59
7403	22	74132	69
7404	22	74136	75
7405	23	74139	95
7406	35	74141	79
7407	35	74142	2.95
7408	26	74143	2.95
7409	23	74144	2.95
7410	22	74145	62
7411	29	74147	1.95
7412	29	74148	1.20
7413	39	74150	1.09
7414	59	74151	67
7416	29	74152	67
7417	29	74153	67
7420	22	74154	1.19
7421	35	74155	78
7422	29	74156	78
7423	29	74157	69
7425	29	74158	1.65
7426	29	74159	2.49
7427	25	74160	88
7429	45	74161	88
7430	23	74162	89
7432	29	74163	87
7437	25	74164	87
7438	29	74165	87
7439	29	74166	1.20
7440	19	74167	1.95
7441	79	74170	1.69
7442	57	74172	4.75
7443	95	74173	79
7444	95	74174	89
7445	79	74175	85
7447	79	74176	75
7447	65	74177	75
7448	79	74179	1.34
7450	19	74180	75
7451	19	74181	1.75
7453	19	74182	75
7454	19	74184	2.25
7459	25	74185	2.25
7460	23	74186	9.95
7470	29	74188	3.90
7472	29	74190	1.15
7473	34	74191	1.15
7474	34	74192	85
7475	38	74193	85
7476	34	74194	85
7479	1.60	74195	68
7480	49	74196	85
7482	95	74197	85
7483	55	74198	1.39
7485	65	74199	1.39
7486	35	74221	1.19
7489	1.75	74251	95
7490	39	74273	1.05
7491	57	74276	1.89
7492	45	74279	75
7493	45	74823	1.40
7494	69	74284	3.90
7495	65	74285	3.90
7496	69	74290	1.25
7497	2.90	74298	95
74100	2.90	74365	68
74107	32	74366	68
74109	37	74367	68
74116	1.95	74368	68
74121	29	74390	1.45
74122	39	74393	1.90
74123	59	74490	1.90

74LS00

74LS00	26	74LS162	1.05
74LS01	28	74LS163	1.05
74LS02	28	74LS164	1.19
74LS03	28	74LS165	89
74LS04	35	74LS166	2.48
74LS05	28	74LS168	1.15
74LS09	35	74LS169	1.15
74LS10	28	74LS170	1.99
74LS11	39	74LS173	89
74LS12	33	74LS174	89
74LS13	47	74LS175	89
74LS14	95	74LS181	2.20
74LS15	33	74LS182	1.15
74LS16	26	74LS191	1.15
74LS17	33	74LS192	98
74LS18	33	74LS193	98
74LS19	33	74LS194	1.15
74LS21	33	74LS195	95
74LS22	33	74LS196	89
74LS26	33	74LS197	89
74LS27	26	74LS221	1.15
74LS28	33	74LS240	1.69
74LS30	55	74LS242	1.69
74LS32	45	74LS243	1.69
74LS33	39	74LS244	1.49
74LS34	26	74LS245	2.20
74LS42	79	74LS247	1.10
74LS47	79	74LS248	1.10
74LS48	95	74LS249	1.19
74LS51	26	74LS251	1.40
74LS51	29	74LS253	1.40
74LS55	29	74LS257	85
74LS55	45	74LS258	98
74LS57	42	74LS259	2.95
74LS57	59	74LS260	65
74LS57	45	74LS261	2.49
74LS57	45	74LS266	59
74LS58A	79	74LS273	1.75
74LS58	1.19	74LS275	4.40
74LS58	45	74LS279	59
74LS59	57	74LS283	99
74LS59	75	74LS290	99
74LS59	75	74LS293	99
74LS59	88	74LS295	1.10
74LS59	98	74LS298	1.19
74LS107	45	74LS324	1.75
74LS109	45	74LS347	1.95
74LS113	43	74LS348	1.95
74LS114	43	74LS352	1.19
74LS120	55	74LS353	1.19
74LS123	1.19	74LS363	1.49
74LS124	1.35	74LS365	69
74LS125	89	74LS366	69
74LS126	52	74LS367	69
74LS130	79	74LS368	69
74LS136	59	74LS373	1.89
74LS138	85	74LS374	1.89
74LS139	85	74LS375	69
74LS145	1.25	74LS377	1.95
74LS148	1.49	74LS385	1.95
74LS151	79	74LS386	65
74LS154	79	74LS390	1.95
74LS154	1.79	74LS393	1.95
74LS155	1.19	74LS395	1.70
74LS156	99	74LS399	2.35
74LS157	85	74LS424	2.95
74LS158	85	74LS668	1.75
74LS159	1.08	74LS670	2.29
74LS161	1.15	74LS378	1.95
74LS133	65	74LS379	1.95
74LS241	1.69	74LS381	2.95
74LS280	2.90	74LS640	2.95
74LS299	2.00	74LS645	2.95
74LS339	1.95	74LS690	1.50

Tel: 1-(800)-821-3628

74S00

74S00	39
74S02	43
74S03	45
74S04	52
74S05	52
74S08	49
74S09	49
74S10	42
74S11	42
74S15	42
74S20	42
74S22	42
74S30	42
74S32	49
74S38	1.19
74S40	49
74S51	42
74S64	46
74S65	46
74S74	69
74S86	72
74S112	72
74S113	72
74S114	72
74S124	3.69
74S133	54
74S134	66
74S135	1.15
74S136	1.69
74S138	1.29
74S139	1.29
74S139	1.29
74S140	73
74S151	1.29
74S153	1.29
74S157	1.29
74S160	2.79
74S174	1.49
74S175	1.49
74S188	2.69
74S194	1.89
74S195	1.89
74S196	1.89
74S240	2.75
74S241	2.75
74S242	2.99
74S243	2.99
74S244	2.99
74S251	1.35
74S253	1.35
74S257	1.29
74S258	1.29
74S260	75
74S280	2.79
74S287	2.99
74S288	2.55
74S373	3.10
74S374	3.10
74S387	2.75
74S471	7.95
74S472	7.95
74S473	7.95
74S474	9.95
74S475	9.95
74S570	5.75
74S571	5.75
74S572	8.95
74S573	8.95
74S940	2.90
74S942	2.90
74S132	2.15
74S161	2.95
74S163	3.15
74S181	2.15
74S189	2.95
74S225	7.75
74S283	4.15
74S289	3.95

LINEAR

LM301CN	35
LM304H	1.98
LM305H	1.89
LM306H	3.25
LM307CN	29
LM308CN	.98
LM309K	1.49
LM310CN	1.25
LM311D/CN	.89
LM312H	1.75
LM317T	1.70
LM318CN	1.49
LM319N/H	1.25
LM320K-XX	1.35
LM320T-XX	1.39
LM320H-XX	1.25
LM323K	4.95
LM324N	95
LM337K	5.95
LM338K	6.95
LM339N	.95
LM340K-XX	1.75
LM340T-XX	1.25
LM340H-XX	1.25
LM341H	1.95
LM348N	1.20
LM350K	5.60
LM358CN	.98
LM360N	1.49
LM372N	1.95
LM376N	3.75
LM377N	2.75
LM380CN/N	1.25
LM381N	1.79
LM383T	1.95
LM386N	1.25
LM387N	1.40

16 RAM CARD

Compatible with:
 DOS 3.3, CP/M,
 Visicalc, PASCAL
\$49.00
 1 YR. WARRANTY

80 Column Card For APPLE II \$99.00

SPEEDY EPROM PROGRAMMER FOR APPLE II PROGRAMMING

2716, 2732, 2764, 27128,
 2532, 2564
IN 30 SECONDS \$119.00

Apple II/IIe Compatible \$222.00 Disk Drive

CONTROLLER CARD \$75.00

SUPER COOLING FANS FOR APPLE

Model BF64S '225.00
 For single computer
 single printer
\$49.50
 Model BF64M '395.00
 For multi-computer
 single printer
 Allow up to four
 computers
\$69.50
 Share one printer

IBM MEMORY EXPANSION KIT

IBM 64K \$52.95
(9 Pcs 64K RAM)

High Quality Diskettes

5 1/4" SS/DD 17/Box
 5 1/4" DS/DD 27/Box

80 Column Dot Matrix Printer

CP-80 by C.T.I.
 80 cps parallel interface
 graphics printing compatible
 with EPSON MX80FT

SALE PRICE \$299.00

TERMS: For shipping include \$2 for UPS Ground or \$3 for UPS Blue Label Air. Items over 5 pounds require additional shipping charges. **\$10 minimum order.**

1-(800) 821-3628



4962 EL CAMINO REAL, SUITE 119 • LOS ALTOS, CA 94022
 (415) 962-9265 • TLX: 171947 HANDWELL LTOS

Voltage Regulators

7805T	75	7905T	85
78M05C	35	7908T	85
7808T	75	7912T	85
7812T	75	7915T	85
7815T	75	7924T	85
7824T	75	7905K	1.49
7805K	1.39	7912K	1.49
7812K	1.39	7915K	1.49
7815K	1.39	7924K	1.49
7824K	1.39	79L05	.79
78L05	69	79L12	.79
78L12	69	79L15	.79
78L15	69	LM323K	4.95
78H05K	9.95	UA78S40	1.95
78H12K	9.95	L TO-92	
K TO-3		C.T TO-220	

DRAM

1M54027	1.99
UPD411	3.00
MM5280	3.00
MK-1108	1.95
MM5298	1.85
4116-300	8.11.75
4116-250	8.11.95
4116-200	8.12.95
4116-150	8.14.95
4116-120	8.29.95
2118	4.95
4164-200	5.95
4164-150	6.95

DIP SWITCHES

4 Position	85
5 Position	95
6 Position	95
7 Position	95
8 Position	95

SOUND CHIPS

AY-3-5912	2.95
AY-3-5912	8.95
AY-3-5912	9.95
AY3-8912	12.95
MC3340	1.49

Z80 SERIES

8000 SERIES

8200 SERIES

6800 SERIES

APPLE HARDWARE

Wholesale

STOCK NUMBER	RETAIL PRICE	SALE PRICE	MIN. ORDER
AP101 16K RAM CARD	\$149	\$30	10
AP102 80 COLUMN CARD	295	89	10
AP104 CLOCK/CALENDAR CARD	195	79	10
AP105 DISK-II DRIVE (W/CTRL CARD)	498	199	10
AP106 DISK-II CONTROLLER	150	45	10
AP107 JOY-STICK DELUX	69	19	10
AP109 LOWER CASE	45	19	10
AP110 PRINTER CARD (PARALLEL)	150	45	10
AP111 RS-232 CARD (SERIAL)	195	79	10
AP112 SUP-R-MOD	39	19	10
AP114 Z-80 CARD	298	99	10
AP116 INTEGER CARD	150	49	10
AP117 EPROM WRITER CARD	279	119	10
AP118 128K RAM CARD (PSEUDO-DISK)	498	259	10 NEW
AP119 FORTH CARD	298	89	10 NEW
AP201 APPLE-II+ COMPAT. 48K KIT	599	229	10
AP202 HARDCASE FOR AP201 (PLASTIC)	175	89	10
AP203 KEYBOARD FOR AP201	139	69	10
AP204 POWER SUPPLY FOR AP201	120	68	10
AP205 APPLE II+ COMPAT. 48K A&T	599	349	10
AP206 APPLE II+ COMPAT. 64K A&T	699	399	10 NEW
AP207 KEYBOARD FOR APPLE-II (DELUX)	169	89	10 NEW
AP208 POWER SUPPLY (DELUX)	139	79	10 NEW
AP301 TANDON TM-50-1 DISK DRIVE (MECHAN.)	249	119	10 NEW
AP401 IBM PC COMPUTER 64K W/2 DRIVE	3550	2195	5

 PRICES WILL BE LOWER FOR LARGER QUANTITY ORDER
 ALL PRICES SUBJECT TO CHANGE WITHOUT NOTICE
K & R COMPUTER CO., LTD.
 * 1440 PACIFIC COAST HWY., #104 *
 * HARBOR CITY, CA 90710 *
 * (213) 530-2577 *

Circle 252 on inquiry card.

VT100

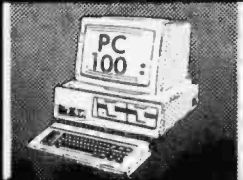

OUR PC100™ SOFTWARE PACKAGE TURNS YOUR IBM®PC INTO A DEC® VT100/102/52 COMPATIBLE TERMINAL

Requires: 64k, 1 drive, 25x80 display, async port, and IBM DOS or QUINX™

PRICED FROM \$89.

Optional: Local Printer & File Transfer

For more information call or write:



7525 Mitchell Road, Mpls., MN 55344 (612) 937-9194

IBM is a registered trademark of International Business Machines. DEC, VT are registered trademarks of Digital Equipment Corp. QUINX is a trademark of Quantum Software Systems. PC100, GMS are trademarks of General Micro Systems.

Circle 192 on inquiry card.

S-100 EPROM PROGRAMMER

EPROM-32

- High quality S-100 board meets or exceeds IEEE-696.
- Programs 1k through 32K (byte) EPROMs.
- Textool zero-insertion-force programming socket.
- EPROM is programmed through I/O ports and can be verified through I/O ports or located in memory space for verification.
- Programming voltage generated on-board.
- Personality Modules simplify adaptation of board to different EPROM types:

PM-1 - 2508, 2758 PM-3 - 2732, 2732A PM-6 - 68764
 PM-4 - 2564 PM-8 - 27128

PM-2 - 2532 PM-5 - 2764

- CP/M-compatible control software
- Includes commands for programming, verification, disk I/O and editing.

\$269.95*
 (A & T)

MicroDynamics Corporation

6363 Poplar Ave. • Suite 105
 Memphis, TN 38119

ORDER DESK:
 1-800-237-8400 ext 440
 Technical Inquiries:
 (901) 662-4054

*Price includes EPROM-32, documentation and two Personality Modules (specify). Additional Modules - \$795. Control software on 8" SSSD diskette - \$9.95, UPS ground - \$2.00, UPS air - \$4.00, COD - \$1.50, foreign add \$15.00, TN add 6% sales tax. VISA and MASTERCARD welcome.

Circle 419 on inquiry card.

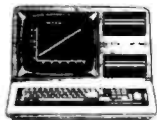

Best Prices On TRS-80 Computers

Our 6th year of discounts

Ed or Joe McManus
 Fgt. Prepaid. Save Tax.
 Toll Free 800-231-3680

Marymac Industries, Inc.
 22511 Katy Fwy., Katy
 (Houston) Tx 77450
 1-713-392-0747
 Telex 774132

See us in the Wall Street
 Journal every Tues., Wed., Thurs.

Circle 288 on inquiry card.

LOAD CELL DIGITIZER 3010



CONVERTS S-100 COMPUTER INTO WEIGHING SYSTEM

Interfaces with load cells and strain gauge transducers
 Professionally designed for industrial applications giving stability superior to high-priced scale indicators

- Fully S-100 IEEE-696 compatible.
- Excitation for up to 8 load cells
- 17 bit. sign & overload at 4 conv. sec.
- 15 bit. sign & overload at 15 conv./sec
- 0.01% accuracy
- Programmable damping filter.
- Selectable S-100 vectored interrupts
- Wide range dead-load and span adjustments
- Conservative and cool-running CMOS circuitry.

Price \$495.00 Custom & OEM versions available.

Scalar Electronix (1982) Inc.
 P.O. Box 0863, Champlain, N.Y. 12919-0863
 (514) 834-7028

Circle 411 on inquiry card.

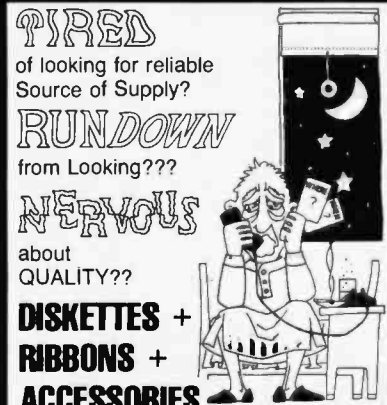

Call Bob Kelly Now. . .
Kelly Computer Supplies
 1811 Carl St. • St. Paul, MN 55113
 Toll Free . . . 800 - 447 - 2929
 MN Res. Call Collect. . . 612/644-9030
MEMOREX - DISKETTES

Circle 255 on inquiry card.

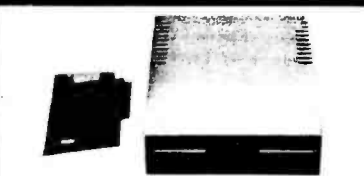

- ** Apple compatible products ****
- Apple II (+, e) slim disk drive . . **\$210.00**
 - Apple II (+, e) controller card . . **\$55.00**
 - Apple keyboard **\$80.00**
 (with upper and lowercase)
 - Apple replacement power supply . **\$80.00**
 (5V/5A, 12V/3A, -5V/0.5, -12V/0.5)
 - Apple replacement plastic case . . **\$80.00**
 - Apple II + compatible computer with 64K and upper and lowercase capability **\$650.00**

Also printer, modem, and monitor are available in lower price. Term: Visa, Mastercard, COD.
Tel 609-667-6330
Roger Electronics, 403 Sheffield Road
Cherry Hill, NJ 08034

Circle 403 on inquiry card.

CHEAP

LOWEST MAIL ORDER PRICES IN THE USA
OCTOBER SPECIALS

ITOH F-10 Starwriter (P or S)	1069
ITOH 8510 AP Prowriter (P)	359
TELEVIDEO 925 terminal	739
NEC 3550 Spinwriter	1749
NEC 7710 Spinwriter (S)	1969
MORROW MD-2 Micro Decision computer with Morrow terminal, Prowriter printer and all software	1699
MORROW MD-2 same except Silver-Reed EXP-500 daisywheel printer	1799

PLEASE CIRCLE READER SERVICE CARD FOR OUR DISCOUNT MAIL ORDER BULLETIN

All items shipped in factory sealed cartons with full manufacturers warranty. We don't cash your check until we ship. If we can't ship in 5 days, your check is returned uncashed.

Quoted prices are mail order only, and valid October only. We cannot accept credit cards, personal or company checks, POs or CODs. Shipping charges collected upon delivery.



CompuClass, Inc.
 7603 Firestone Bl.
 Downey, CA 90241
 (213) 566-3556

Authorized dealer: Columbia, Corona, Diablo, Eagle, ITOH, Morrow, NEC, North Star, Qume, Seiko, Silver-Reed, Televideo and other major brands.

Circle 98 on inquiry card.

TDK

flexible disks

Call Free **(800)235-4137**
 for prices and information.
 Dealer inquiries invited.
 C.O.D. and charge cards accepted.

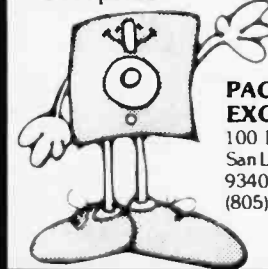

PACIFIC EXCHANGES
 100 Foothill Blvd.
 San Luis Obispo, CA
 93401 (In Cal. call
 (805) 543-1037)

Circle 341 on inquiry card.

**TOLL-FREE
ORDERING:
800-222-8686**

CCT CUSTOM COMPUTER TECHNOLOGY

1 CRAFTSMAN COURT — BOX 4160 — SEDONA, ARIZONA 86340

**FOR TECHNICAL SUPPORT/
SERVICE / IN ARIZONA:
602-282-6299**

Purchase your Hardware and Software directly from an OEM/Systems Integrator. Take advantage of our buying power! We stock a full line of Board Level Components, Software, and Peripherals. Call for your needs. We'll give you the Lowest Prices, and the Technical Support and Know-How we are quickly becoming well-known for. Satisfied Customers Nationwide! The Nations's Custom Systems House for Business, Education and Science. Call for a system quote.

• FOREMOST QUALITY • ADVANCED SUPPORT • REASONABLE COST •

OF PRIME INTEREST

Our prime interest at CCT is **service and support**. We build and sell hundreds of systems per year to the serious computer market. We rigidly adhere to our strict policy of reliable machines, and reliable people behind them. We feel the CompuPro product line to be the state-of-the-art of the computer industry.

THE CCT EXCLUSIVE WARRANTY

With any system we build, we provide, in writing, an unconditional 12 month **direct warranty** on the entire system, including mainframe, boards, drives, power supplies, cabling and peripherals! We offer guaranteed 24 hour in-house repair and/or replacement with just a toll-free phone call. We can offer this, since we are so sure of our level of quality and reliability. It's great to know that in the event of a problem, you're not out of business waiting on service turnaround. We deliver!

Our various OEM contracts with all the manufacturers of the components we integrate, allow us this unprecedented flexibility. No factory O.K.'s necessary — just get it running — **NOW!**

Wyse 100 terminal \$699
 WS Prom Option - Installed \$50
 Mitsubishi 8" DSDD drives, full or half height. Set-up FREE OF CHARGE ... \$449
 Okidata 82 \$419 / 83 \$679
 84 \$1029 / 92 \$559 / 93 \$930
 Ashton-Tate dBASE II 8" or MD ... \$299
 Supercalc 86 - for CP/M 86 & MP/M ... \$99
 Visual Terminals in stock Call
 Lear Siegler ADM 20 \$499
 Freedom 50 \$499/100-\$549
 Hays Modem-\$259 • Diablo 620-\$1029

We carry a full line of software in all available formats at discount prices.

TECH TIP CORNER

dBASE II USERS - CUSTOM TERMINAL KEYS! Implement your arrow keys; emulate Wordstar edit commands - send an SASE with \$2.00 - (ATTN: TTC). Tell us your arrow key codes. We'll return easy, detailed instructions to change almost anything. It's beautiful — Pat...

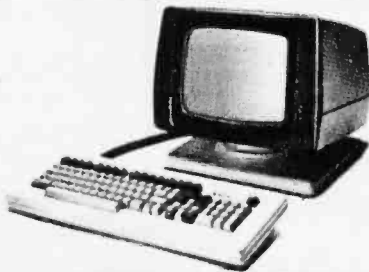

**PROFESSIONAL LEVEL BUSINESS SYSTEMS
STATE-OF-THE-ART QUALITY, PERFORMANCE, RELIABILITY**

CCT ANNOUNCES: OUR OWN IN-HOUSE ENGINEERED CUSTOM COMPUPRO SYSTEMS

CCT-1 — ENTRY LEVEL S-100 BUSINESS SYSTEM

- Enclosure 2-Desk-20 Slot Mainframe •
- CPU 8085/88 - 6Mhz 8085/8Mhz 8088 •
- Disk 1 - DMA Floppy Disk Controller •
- RAM 16 - 64K Static RAM - 12 Mhz •
- Interfacer 4 - 3 Serial/2 Parallel I/O •
- CCT 2.4 Dual 8" Mitsubishi DSDD Drive System - 2.4 Megabytes •
- CP/M 80 - 2.2 LD/M - CCT Modified •
- All Cabling, Complete CCT Assembly, Testing, and Minimum 20 Hour Burn-in •

**INTRODUCTORY PRICE:
\$3,399**

RUNS ALL STANDARD 8" CP/M SOFTWARE - INCLUDES OUR EXCLUSIVE 12 MONTH DIRECT WARRANTY

CP/M MP/M NOTE: Each copy we furnish is CCT modified for the target system. M-Drive/H and hard disk drivers are furnished, and the BIOS optimized for the fastest disk step rate, as well as terminal and printer compatibility.

★ ★ CCT-2 — THE FASTEST MICROCOMPUTER IN THE WORLD!! ★ ★

- Enclosure 2-Desk •
- CPU 8086 - 10Mhz •
- 128K - 16 Bit Memory •
- Interfacer 3-8 •
- 90K Baud Parallel Terminal Board •
- Disk 1 •
- All Cabling, Complete CCT Assembly, Testing, & Minimum 20 Hour Burn-in •
- 78 Key Professional Ergonomic Keyboard •
- High Resolution Amber Monitor. •
- CCT 2.4 Dual DSDD Drive System •

**INTRODUCTORY PRICE:
\$6,799**

RUNS ALL CP/M 86 SOFTWARE - ULTRA FAST - INCLUDES 12 MONTH DIRECT WARRANTY

*Ask about CCT-3 (68K Version similar to above) w/256K RAM — \$7,699

We are the largest in the custom configuration of complete state-of-the-art S-100 systems, at package pricing, with integration, burn-in and programming. We custom build CompuPro systems / hard disk systems for business applications. Call for CompuPro literature. CCT system configuration data and technical information. We can save you money!

★ SUPER PRICES ★ COMPUPRO COMPONENTS ★ IN STOCK ★

SYSTEM SPECIALS — ALL CCT A&T, BURNED IN:

816A-\$4299	816B-\$4999	816C-\$6499
M-Drive CP/M w/RAM Purch-\$49	Disk 1w/CP/M-\$449	M-Drive/H-512K-\$1149
CPU 8085/88-\$319	CPU 8086/87-\$579/10Mhz-\$659	CPU 68K-\$519/10Mhz-\$639
CPU 286 \$1249/10Mhz-\$1359	Disk 1-\$369	Disk 2-\$599
RAM 17 (12Mhz)-\$329	RAM 16 (12Mhz)-\$359	RAM 21 (128K)-\$779
Interfacer 1 - \$229	Interfacer 2-\$249	Interfacer 3-5-\$399/3-8-\$459
System Support 1-\$299	Enclosure 2-Desk-\$599/Rack-\$649	20 Slot Motherboard-\$210
CP/M 80-\$99	CP/M 86-\$150	MP/M 8-16-\$699
		CP/M 68K-\$279
		Forth 68K-\$169

86 Upgrade Kit: Consists of CP/M 86, 64K Ram, System Support 1, Cable - \$749
Call for CSC Boards — New Releases — Operating System Mods/Updates

★ PRICE BREAKTHROUGH ★ Hard Disk Subsystems

CCT/Fujitsu 5 1/4" subsystem, includes Disk 3, custom enclosure & power supply, all cabling, A&T, formatted, burned-in. Ready for any CompuPro or similar S-100 system:
CCT-5 (5.5 Meg)-\$1599
CCT-10 (11 Meg)-\$1899 / CCT-20 (22 Meg)-\$2299

?? HARD DISK DECISIONS ?? Hard/Floppy Combinations

An exclusive CCT innovation. CCT/Fujitsu/Mitsubishi ultra-system: 5 1/4" hard disk next to a 1.2 Meg. DSDD 8" floppy. Includes Disk 3, custom horizontal enclosure and power supply, all cabling, A&T, formatted, burned-in. Will stand alone in any CompuPro system:
CCT-5/1-\$2099 CCT-10/1-\$2399 CCT-20/1-\$2799

★ NEW DISK 3/5 1/4" HD SYSTEMS ★ 2.4 Megabyte Floppy Systems

CCT/Mitsubishi 2.4 Megabyte Dual DSDD 8" system. Includes custom horizontal enclosure, all cabling, A&T, burned-in. This is the fastest system available:
\$1149
 With stacked half-height drives: **\$1175**

All Systems Carry Our Exclusive 12 Month Warranty.

Prices & availability subject to change. All products new, and carry full manufacturer's warranties. Call for catalog. Free technical help to anyone. We can configure boards & software for your system. Plug-in and go. Arizona Residents add sales tax. **CompuPro®** Trademark — W.J. Godbout; **CP/M® MP/M®** Trademarks — Digital Research

THUNDERWARE

Statistics & Mathematics

New on the market! An industry proven software package which may well be all you'll ever need in the way of math and data analysis! Just look at what you get!

Statistics: Linear Regression, Correlation, Curve Fitting (power, exponential, log), Distribution Analysis (Normal, Weibull, Binomial, Poisson, Hypergeometric)

Mathematics: Vectorial Analysis, Quadratic Eq'n, Complex Arithmetic, Base b to Base 10, Permutations & Combinations, Factorials, Iterative Sol'n to f(x) = 0, Numerical Integration, Triangle Sol'n's, Hyperbolic Transcendentals, Simultaneous Eq'n's

Available for the IBM PC and the TI-99/4A at an introductory price of only \$149.95!

THE THUNDERWARE COMPANY
P.O. Box 12587
Lexington, KY 40583
(606) 259-0178

Circle 470 on inquiry card.

SANYO

SANYO BUSINESS SYSTEMS

MBC-1100 COMPUTER #1777

Includes: CPU, Keyboard, green 24 x 80 screen, 2 disk drives, with complete business software—WORDSTAR, MAILMERGE, SPELLSTAR, CALCSTAR, INFOSTAR, CP/M system and BASIC. (We will add a modem and software for only \$99)

MBC-550 PC COMPUTER #777

The new PC that runs most IBM software! This is a real quality unit with great looks. Includes: CPU, keyboard, 1 disk drive, MS-DOS, word processor, spreadsheet and more.



IBM COMPATIBLE PC #2092

Includes: 2 drives (1-320 K floppy and 1-180K RAM drive), 256K RAM, Green or Amber Hi-Res Screen 640 x 320, MS-DOS, GW Basic, Graphics, Parallel port, serial port, 4 IBM type slots. We will add \$400 of software for \$99

TTX 1014 Daisy Wheel Printer #555

Includes: Tractor-feed, friction feed, serial interface, parallel interface, ribbon and daisy wheel:

Send cashier's check, money order or personal check to ANN'S COMPUTERS, 419 E. Washington Ave., Unit 3A, Gilbert, AZ 85234 or call (602) 892-6659 Visa and MC add 4%

Circle 80 on inquiry card.

FACTORY AUTHORIZED SALES & SERVICE

Wide choice of lease & lease/purchase plans

CompuPro

Sys A \$103/mo., Sys B \$123/mo., Sys C \$160/mo., Sys D \$255/mo.

MORROW DESIGNS DECISION 1

D120 \$110/mo., D200 \$117/mo., D210 \$130/mo., D220 \$155/mo.

Tarbell

Rebel \$78/mo., Rebel 16 meg \$103/mo., Rebel 16 meg multi-user \$124/mo.

Payments are example. Ask about other systems, boards, etc.

Ask about bonus software. Accounting, games, utilities, PRINTERS, TERMINALS, SOFTWARE—CALL

We cater to experienced users, gov'l. agencies, and corp. customers

TERMS: Cash with order. You pay all freight. Add 5% for 2% 10/Net, 30 AAA1 or Fed 1/State P.O. 2%/mo. carrying chg.

CALL US 9 AM to 10 PM

CostPlus COMPUTERS

P.O. Box 6114 • Birmingham, AL 35259-6114

205 879-5976 205 879-4735 Our bank is 1st National of Birmingham, (205) 326-5120

Circle 126 on inquiry card.

300 BAUD	MODEMS	1200 BAUD
SIGNALMAN... Free hour on 'SOURCE'		
300 BAUD direct connect		\$ 69
300 BAUD AUTO DIAL/ANS		\$99
300/1200 AUTO DIAL/ANS		\$319
US ROBOTICS... 300/1200 AUTO 'Hayes Compatible'		
'Password' with cables, sprk		\$339
'Auto 212' dlxe		\$419

DOT MATRIX	PRINTERS	LETTER QUALITY
GEMINI 10x 120 cps graphics		
PROWRITER 120 cps hi density		
JUKI daisy wheel 18 cps		
DAISYWRITER 40 cps		

CPM	COMPUTERS	IBM
Eagle	SCALL	Columbia P.C.
Kaypro	HARD DISKS	Corona P.C.
Televideo	PORTABLES	Eagle P.C.

IMAGE COMPUTERS

P.O. Box 1164, Cardiff, CA 92007

CALL TO ORDER:

619 436-7669

619 436-8317



VISA/MC ADD 3%

Circle 220 on inquiry card.

Serial ← ||||| → Parallel



PRINTERS!
PLOTTERS!
PUNCHES!
ROBOTS!

Convert What You Have To What You Want!

- * RS232 Serial
- * 8 Baud Rates
- * Latched Outputs
- * Centronics Parallel
- * Handshake Signals
- * Compact 3 1/2 x 4 1/2 x 1 1/2

No longer will your peripheral choices be limited by the type of port you have available! Our new High Performance 700 Series Converters provide the missing link. Based on the latest in CMOS technology, these units feature full baud rate selection to 19.2K, with handshake signals to maximize transfer efficiency. Detailed documentation allows simplified installation. Order the Model 770 (Ser/Par) or Model 775 (Par/Ser) Today!

Buffer Products (Coming Soon!) Engineering 1501 8 Pine Street Post Office Box 2233 Orange, California 92630

only \$89.95
Connector Option \$10.00
CA Residents 6% tax
UPS Shipping \$3.00

CALL (805) 487-1665 or 487-1666 For FAST Delivery

Circle 175 on inquiry card.

512K BYTE RAM for IBM PC — XT

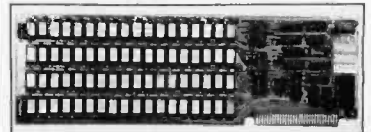

\$225 WITH 64K BYTES INSTALLED
\$595 WITH 512K BYTES INSTALLED
\$5.00 FOR 4164 CHIP (200NS ACCESS)

- * 1 YEAR WARRANTY ON INSTALLED SYSTEM
- * PARTY CHECK LOGIC
- * ALL IC LOCATIONS SOCKETED
- * MEMORY MAY BE LOCATED ON ANY 64K BOUNDARY
- * SOME SPLIT ADDRESSING CAPABILITY
- * TOTAL SPLIT ADDRESSING ON 64K BOUNDARY ON REQUEST

APPLIED LOGIC, INC.

PO BOX 328

JAMAICA, NEW YORK 11415

(212) 459-4064

prices subject to change without notice.

Circle 43 on inquiry card.

TYPED

of looking for reliable Source of Supply?

RUN DOWN

from Looking???

NERVOUS

about QUALITY???

DISKETTES + RIBBONS + ACCESSORIES

Call Bob Kelly Now...

Kelly Computer Supplies

1811 Carl St. • St. Paul, MN 55113

Toll Free ... 800 - 447 - 2929

MN Res. Call Collect. . . 612/644-9030

3M SCOTCH DISKETTES



Maxell Floppy Disks

The Mini-Disks with maximum quality.



Dealer inquiries invited. C.O.D.'s accepted. Call FREE (800) 235-4137.



PACIFIC EXCHANGES

100 Foothill Blvd., San Luis

San Luis Obispo, CA 93401.

In Cal. call (800) 592-5935 or

(805)543-1037.

Circle 341 on inquiry card.

DISK DRIVES

(For PC, Mod I, III & IV)

Tandon TM55-2	\$239
Tandon TM100-1	\$189
Tandon TM100-2	\$239
Tandon TM100-4	\$339
CDC 9409	call.
Case and PS.	\$ 45

PC EXPANSIONS

MAYNARD	
DISK CONTROLLER	\$155
PP add \$50 SP add \$70	

QUADRAM	
Quad bd. or Quad. II (64K)	\$269

AST	
Combo Plus. 64K & SPC.	\$269
Mega Plus: 64K & SC	\$269
I/O Plus (SC)	\$114
2nd S or P or Game.	\$ 35

64K CHIPS	
Set of nine	\$ 55

EPSON	
Printers	call

VLM Computer Electronics

10 Park Place • Morristown, NJ 07960

(201) 267-3268 Visa, MC, Check or COD.

Circle 256 on inquiry card.

Circle 499 on inquiry card.

LIQUIDATION SALE

PERTEC 2000

MULTI-USER SYSTEM



\$2195

Original Manufacturers Price \$11,995

California Digital has recently participated in the purchase of several hundred Pertec 2000 microcomputers. These units are brand new 1983 production, shipped in factory sealed containers. California Digital is offering these multi-user systems at a fraction of its original price.

This microcomputer is the perfect low cost system for any business application requiring high reliability and multi-user flexibility.

The Pertec 2000 is an 8085 small business computer featuring dual 8" disk drives, 12" green phosphor screen and CPU integrated into a single compact unit with detachable keyboard. The keyboard features a numeric pad as well as a cursor control cluster. The Pertec 2000 is supplied with 64K/Byte of memory expandable to 256K. This system comes standard with both an RS-232 serial port as well as a Centronics parallel printer port. The computer will support two users and can be upgraded to a five user system.

The Pertec 2000 is supplied with Pertec BASIC, multi-tasking MTX operating system and CP/M 2.2. This computer is still in current production. Service as well as service contracts are available from Pertec.

The CompuPro Corporation has recently relocated their facility to Hayward California. In the move, several logistic problems occurred resulting in California Digital being double and even triple shipped pending orders. William J. Godbout, the president of CompuPro, has asked us to liquidate the excess inventory rather than send the product back to Hayward.

In order to clear our warehouse, we are offering these boards at a substantial savings. We are, however, asking for prepayment on these orders because of the low profit involved. A surcharge may be added to credit card or open account purchases.

GODBOUT

COMPUPRO SALE

CPU 68K is the most advanced 68000 board available. It includes sockets for an optional memory management unit and up to 16K bytes of EPROM.

GBT-68K Assembled	695	499
GBT-68KC CSC	850	619

CPU 86/87 lets you take advantage of the 8086's large library of ultra-efficient 16 bit software. Includes sockets for 8087 math co-processor and 80130 firmware chips.

GBT-8687 Assembled	750	545
GBT-8687C CSC	850	619

CPU 8085/8088 is the original, much imitated dual processor board. When you need the best of both worlds 8 bit and 16 bit micro-processor application the CompuPro dual processor board delivers results.

GBT-8588 Assembled	495	359
GBT-8588C CSC	595	429

CPU Z is the premium 8 bit CPU that includes all standard Z80A features along with all the necessary options to insure backward compatibility with most older S-100 mainframes.

GBT-Z80 Assembled	325	239
GBT-Z80C CSC	425	319

CPU 16032 features the National NSC 16032 that has true 32 bit internal architecture which resembles that of a minicomputer.

GBT-16032 Assembled	pending	pending
GBT-16032C CSC	pending	pending

CPU 286 is based around Intel's iAPX 286/10 sixteen bit microprocessor. Upward compatible from the CompuPro 8085/8086.

GBT-286 Assembled	1595	1147
GBT-286C CSC	1750	1259

MEMORY BOARDS

RAM 16 is 64 K/Byte of high speed (10 MHz) low power static memory. This board performs both 8 bit and 16 bit data transfers insuring complete compatibility with all 696/S-100 microcomputer systems.

GBT-R16 Assembled	550	399
GBT-R16C CSC	650	469

RAM 17 provides 64 K/Byte of 8 bit static memory. DMA data transfer and 24 bit extended addressing make the RAM 17 the new economical standard.

GBT-R17 Assembled	399	289
GBT-R17C CSC	499	359

RAM 21 features 128 K/Byte of low power static memory. This board is capable of doing both 8 bit and/or 16 bit DMA data transfers.

GBT-R21 Assembled	1095	789
GBT-R21C CSC	1245	899

RAM 22 is 256K/Bytes of high speed low power static memory. This board does both 8 and/or 16 bit data transfers at 12 MHz.

GBT-R22 Assembled	1750	1250
GBT-R22C CSC	1895	1350

M-DRIVE/H emulates 512 K/Bytes of floppy disk storage in solid state memory. System down loads data from magnetic storage and stores this information in dynamic RAM increasing performance by as much as 3500%.

GBT-MDH Assembled	1895	1365
GBT-MDHC CSC	2095	1495

DISK CONTROLLERS

DISK 1 provides advanced capabilities required by today's single or multi-user microcomputers. Disk 1 incorporates the NEC765 controller LSI circuit in an unequaled floppy disk board featuring DMA arbitration.

GBT-DSK1 Assembled	495	359
GBT-DSK1C CSC	595	429

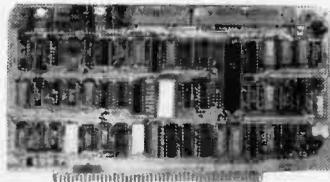

DISK 2 interfaces to most 8" and 14" Winchester disk drives. Directly accesses up to 16 M/Byte. The Disk 2 allows your hard Winchester system to operate at its peak potential by providing high speed DMA transfers required by sophisticated microcomputer systems.

GBT-DSK2 Assembled	795	575
GBT-DSK2C CSC	895	649

DISK 3 controls up to four Seagate 506 compatible 5 1/4" Winchester disk drives. On board processor relieves host CPU of disk overhead enhancing performance of entire system.

GBT-DSK3 Assembled	795	575
GBT-DSK3C CSC	895	645

INTERFACER 1 features two independently addressable RS-232 I/O ports. Each port is baud rate selectable from 50 to 19,200 allowing for simultaneous driving of fast and slow devices.

GBT-133A Assembled	295	219
GBT-133AC CSC	370	269

INTERFACER 2 provides three fully duplexed parallel ports, each containing 16 latched data lines along with strobe, enable and attention. One RS-232 port is included in this unique interface.

GBT-150A Assembled	325	235
GBT-150AC CSC	399	289

INTERFACER 3 is an eight channel multi-user serial I/O board designed for high performance industrial and scientific applications. The Interfacer 3 is capable of high speed synchronous communications with baud rates up to 250K.

GBT-138A Assembled	599	429
GBT-138AC CSC	699	499

INTERFACER 4 is really the only interface board most systems will require. The Interfacer 4 consists of two async./sync. and one async. RS-232 port with 5 handshaking lines. The board also is equipped with a Centronics parallel printer port.

GBT-187A Assembled	450	325
GBT-187AC CSC	540	389

SYSTEM SUPPORT incorporates the most popular and most needed system support functions onto one single board. 4K/Bytes of EPROM, battery back up, clock calendar and three 16 bit interval timers are among some of the features of this special purpose board.

GBT-SYS1 Assembled	450	325
GBT-SYS1C CSC	550	395

California Digital

Post Office Box 3097 B • Torrance, California 90503

TOLL FREE ORDER LINE
(800) 421-5041

TECHNICAL & CALIFORNIA
(213) 679-9001

CALIFORNIA DIGITAL

Post Office Box 3097 B • Torrance, California 90503

★ **FREE** ★
Plastic library case supplied with all
diskettes purchased from California Digital

\$19.95

New Low Price

Private labeled for California Digital by one of the most respected producers of magnetic media. Each diskette is certified double density all 40 tracks. To insure extended media life, all diskettes are manufactured with a reinforced hub. Each box of diskettes is supplied with a free plastic library case.
Soft sector CAL-501 Ten sector CAL-510



5 1/4" DISKETTES
WITH LIBRARY CASE
\$26.50

Your Choice
**SCOTCH
MEMOREX
VERBATIM**

Single Side Double Density

Soft Sector 10 Sector 16 Sector

SCOTCH	744D-0	744D-10	744D-16	26.50
MEMOREX	3481	3483	3485	26.50
VERBATIM	525-01	525-10	NA	26.50
MAXELL	MD1	MH1-10	MH1-16	26.50
DYSAN	104/1D	107/1D	NA	45.00

Double Side Double Density

SCOTCH	745-0	745-10	745-16	39.00
VERBATIM	550-01	550-10	NA	42.50
MAXELL	MD2-D	MH2-10D	MH2-16D	45.00
DYSAN	104/2D	107/2D	NA	49.50
DYSAN 96	204/2D	NA	NA	59.50

EIGHT INCH DISKETTES

Single Side Single Density		Single Side Double Density			
SCOTCH	740-0	29.50	SCOTCH	741-0	39.00
MEMOREX	3060	29.50	MEMOREX	3090	35.00
DYSAN	3740/1	39.50	DYSAN	3740/D	57.50
Thirty Two Sector		Double side Double Density			
SCOTCH	740-32	29.50	SCOTCH	743-0	47.50
			MEMOREX	3114	39.50
			DYSAN	3740/2D	65.00

File & File 5 1/4" stores 50 diskette
File & File 8" stores 50 diskette
Scotch head clean kit #7 & 8
Plastic library cases 5 1/4 & 8" SRW L5 2.95

23"
COMPOSITE
MONITOR
\$159

Ideal monitor
for classroom
demonstrations.

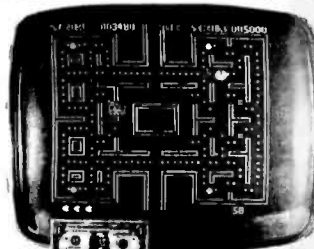

Ever try gathering a classroom of students around a 12" monitor? Here is your opportunity to purchase a 23" high resolution monitor at a reasonable price. These units accept standard composite video signals generated by most personal computers including the Apple and IBM. Attach it your computer and in second you are shooting down Klingons in wide screen video.
NOT BW23 35 Lbs. Monitors are open frame and for safety should be enclosed. Wood grained enclosure for above \$35.00 additional CAL-ENC23 15 Lbs



SPECIAL

Shugart 410

\$129



These Shugart 410 5 1/4" disk drives are all factory fresh 1983 production, recently purchased from the Four Phase Division of the Motorola Corporation. These disk drives are single sided 80 track (96 TP) suitable for use with the Radio Shack Model 1 and Model 3. Or any other application that can support an 80 track second drive such as the IBM/PC. The 410 is full height and functionally the same as the Tandem TM 100-3. Complete with power connector and installation manual.
When these Shugart 410's are liquidated the price will revert to our regular price of \$249. SHU-SA410

MEMORY

16K DYNAMIC	2732 EPROM
1.95	4.95
4116 150ns.	450ns.
64K DYNAMIC	16K STATIC
5.95	4.95
4164 150ns.	6116 200ns.

2764 EPROM SALE \$5.95

DYNAMIC MEMORY		1.31	32	100	+
4027 JK dynamic 250ns	ICM-402750	1.99	1.05	1.75	
4116 150ns 16K	ICM-4116150	1.99	1.85	1.75	
4116 200ns 16K	ICM-4116200	1.89	1.75	1.65	
4164 150ns 64K 128 refresh	ICM-4164150	5.95	5.75	5.55	
41256 150ns 256K	ICM-41256150	Available	Jun 84		
STATIC MEMORY		1.29	1.19	1.15	
21102 200ns 1K static	ICM-21102200	1.49	1.25	1.15	
21102 450ns 1K static	ICM-21102450	1.29	1.05	0.99	
2112 450ns 2K static	ICM-2112450	2.99	2.85	2.75	
2114 300ns 1K x 4	ICM-2114300	1.95	1.85	1.75	
4034 1MS 450ns 4K x 4	ICM-4034450	3.49	3.25	2.99	
5257 300ns 4K x 1	ICM-5257300	2.90	2.25	1.99	
6116 P3 200ns 2K x 8	ICM-6116200	4.50	4.75	4.65	
6116 P3 150ns 2K x 8	ICM-6116150	4.50	4.75	4.60	
6167 2167 100ns 16K x 1120 par	ICM-6167100	7.95	7.50	7.90	
EPROMS		4.95	4.75	4.55	
2708 150ns 1K x 8	ICE-2708	4.95	4.75	4.55	
2716 450ns 2K x 8	ICE-2716	4.95	4.75	4.55	
2716MS 150ns Tri voltage	ICE-2716TMS	7.95	7.65	7.25	
2732 450ns 4K x 8	ICE-2732	4.95	4.75	4.55	
2732 350ns 4K x 8	ICE-2732350	8.50	8.00	7.60	
2753 450ns 4K x 8	ICE-2753	10.00	9.90	9.60	
2764 350ns 8K x 8	ICE-2764	9.95	9.60	9.27	
27128 350ns 16K x 8	ICE-27128	29.95	28.37	27.46	

CONNECTORS

S-100 Gold		DB25P	
GOLD S-100 EDGE CARD CONNECTORS		DB25P	
Imra s/1 250	CNE-1M5	2.95	2.50
Sulfins M/Frel	CNE-H100	4.15	3.85
S-100 Wire W	CNE-WHD	3.95	3.50
Atair 140 s/1	CNE-100A	4.95	4.49
.156" CENTER EDGE CARD CONNECTORS		DB25P	
22 44 E/rel	CNE-415	2.50	2.15
4372 Moto s/1	CNE-725	6.60	6.15
36/72 D/G s/1	CNE-725	5.95	5.50
RIBBON CONNECTORS		DB25P	
DB25P male	CND-25P	5.65	5.25
DB25S female	CND-25S	5.95	5.50
57-3036P male	CNC-36P	7.95	6.75
57-3036P female	CNC-36S	7.95	6.75
20 pin edge	CNI-DE20	4.35	3.50
25 pin edge	CNI-DE25	2.75	1.85
26 pin socket	CNI-DS26	4.95	3.50
34 pin edge	CNI-DS34	3.50	2.40
34 pin socket	CNI-DS34	4.95	4.50
34 pin edge	CNI-DS34	4.95	4.50
50 pin edge	CNI-DS50	5.95	5.60
50 pin socket	CNI-DS50	4.95	4.60
"D" TYPE		catalog	
DE9P male	CND-9P	1.60	1.30
DE9S female	CND-9S	2.25	2.00
DE hood	CND-9H	1.50	1.30
DA15P male	CND-15P	2.35	2.10
DA15S female	CND-15S	2.50	2.20
DA15 hood	CND-15H	1.60	1.35
DB25P male	CND-25P	2.50	1.95
DB25S female	CND-25S	3.35	2.95
DB25 hood	CND25H	1.35	1.17
DC17P male	CND-17P	4.20	3.95
DC17S female	CND-17S	5.95	5.55
DC37 hood	CND-37H	2.25	1.95
DD50P male	CND-50P	5.50	5.10
DD50 hood	CND-50H	2.60	2.40
Hardware 2'x5' CND-2HS		99	69
AMPHENOL CENTRONICS TYPE		57-3203 36P CNC-36P	
IEEE488 C card	CND-24P	7.95	6.35
IEEE488 C card	CND-24P	7.95	6.35
DISK DRIVE POWER CONNECTORS		8 5 pin D/C	
8 5 pin D/C	CNP-6DC	1.95	1.29
8 3 AC S/O	CNP-3CS	1.69	1.09
8 3 AC D/S	CNP-3DS	1.69	1.09
5 1 4 pin D/C	CNP-4DC	1.79	1.19
3 pin D/F recept	CNP-D3P	2.59	1.99

BLOWOUT SALE

\$169

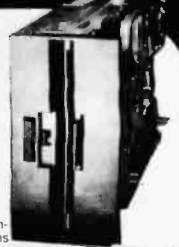

California Digital has recently participated in the purchase of several thousand Siemens FDD 100-8 floppy disk drives. These units are electronically and physically similar to that of the Shugart 801R. All units are new and shipped in factory sealed boxes. Manual and power connectors supplied free upon request. Your choice 115 Volt, 60 Hz. or 230 Volt, 50 Hz.

NOTE! European customers: We have a large quantity of 230 volt 50 Hz units warehoused in Frankfurt Germany. Arrangements can be made to will call these drives in quantities of 50 or more. In Frankfurt reducing import duty and freight charges.

REMEX DOUBLE SIDED \$219

California Digital has just purchased a large quantity of Remex RFD-4000 Eight Inch double sided disk drives. Remex is the only double sided disk drive that has a double gimbal mounted head assembly that guarantees lower head tracking. This drive is mechanically solid. Remex has always been known for producing premium products for the floppy disk market. The Remex company is a subsidiary of the Ex-cel-o Corporation, a Fortune 500 Company.

Eight Inch Single Sided Drives		One	Two	Ten
SHUGART 801R		385	375	365
SHUGART 810 Half Height		385	375	365
SIEMENS FDD 100-8		169	169	159
TANDON 848E-1 Half Height		369	359	349
Eight Inch Double Sided Drives		495	485	475
SHUGART SA851R		495	485	475
SHUGART 860 Half Height		495	485	475
QUME 842 "QUME TRACK 8"		459	459	449
TANDON 848E-2 Half Height		485	475	465
REMEX RFD-4000		219	219	209
MITSUBISHI M2894-63		379	375	369
MITSUBISHI M2896-63 Half Ht.		459	449	409
Five Inch Single Sided Drives		235	229	225
SHUGART SA400L		129	119	call
SHUGART SA410 96TPI/80 Trk.		169	159	149
SHUGART SA200 3/4 Height		169	159	149
TANDON TM100-1		189	179	175
TANDON TM50-1 Half Height		465	450	439
TEAC FD-55A Half Height		465	450	445
Five Inch Double Sided Drives		319	309	299
SHUGART SA450		259	249	239
SHUGART SA465 Half Ht. 96TPI		289	279	269
TANDON TM50-2 Half Height		215	209	199
TANDON TM55-4 half Ht. 96TPI		329	319	309
TANDON 100-2		279	269	259
TANDON 101-4 96TPI 80 Track		369	355	350
MITSUBISHI 4851 Half Height		259	249	245
MITSUBISHI 4853 1/2 Ht. 96TPI		339	329	319
MITSUBISHI 4854 1/2 Ht., 8" elec.		465	449	439
QUME 142 Half Height		239	229	219
TEAC FD-55B Half Height		329	319	299
Five Inch Winchester Hard Disks Drives		895	865	825
SHUGART 612	13 M/Byte	795	775	755
SHUGART 706	6 M/Byte, Half Ht	895	865	825
SHUGART 712	13 M/Byte, 1/2 Ht.	555	495	475
SEAGATE 506	6 M/Byte	895	875	855
TANDON 503	12 M/Byte			

Upon request, all drives are supplied with power connectors and manual

ENCLOSURES

California Digital manufactures an assortment of stock and custom disk drive enclosures. If the volume is justified we will custom design an enclosure for your application. The following stock disk drive enclosures are available. All include power supplies the 8" enclosures are supplied with exhaust fans.

Horizontal mount two 8" full height drives.	\$279.00
Vertical mount two full height 8" disk drives.	\$299.00
Horizontal mount one full height or two half height 8" drives.	\$239.00
Vertical mount two full height 5 1/4" disk drives.	\$139.00

TOLL FREE ORDER LINE
(800) 421-5041
TECHNICAL & CALIFORNIA
(213) 679-9001

Shipping: First five pounds \$3.00. Each additional \$.50.
Foreign orders: 10% shipping. Excess will be refunded.
California residents add 6 1/2% sales tax. COD's discouraged.
Open accounts extended to state supported educational institutions and companies with a "strong" Dun & Bradstreet.
Warehouse: 15608 Inglewood Blvd.
www.americanradiohistory.com

VIDEO DISPLAYS

look for low cost— high quality video displays

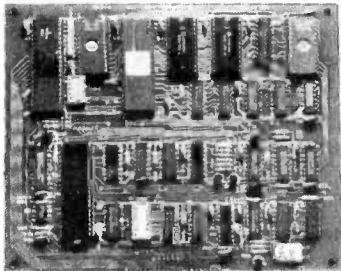

VIDEO TERMINAL BOARD. This is a complete stand alone Video Terminal board. All that is needed besides this board is a parallel ASCII keyboard, standard NTSC monitor, and a power supply. It displays 80 columns by 25 lines of UPPER and lower case characters. Data is transferred by RS232 at rates of 110 to 9600 baud

—switch selectable. Complete source listing is included in the documentation. Both the CRT program and the character generator are in 2716 EPROMS to allow easy modification to your needs. This board uses a 6502 microprocessor and a 6845 crt controller. The serial input port is interrupt driven. Assembled and tested part number 82-018A \$199.95. The bare board with the crystal and EPROMS, part number 82-018B \$89.95

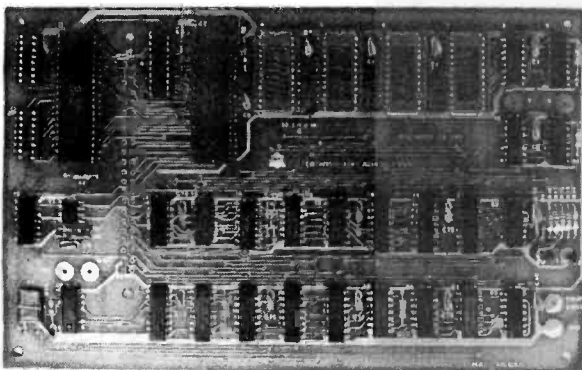

MINI VIDEO. This board can be used to add a video display to your aim or other computer. It can also, with the addition of a parallel keyboard, 5V power supply, and video monitor, run Tom Pittman's Tiny Basic. The display format is 40 columns by 24 lines. This board has two parallel ports (6522), a 6502 MPU 4K RAM, 2 or 4K EPROM. The assembled video board without EPROMS, part number 82-140A \$149.95. The Tiny Basic EPROM \$39.95. The character generator EPROM \$19.95. The parallel input EPROM \$19.95.

To order: Send check or money order. Add 6.5% tax in California. Add 5% shipping for orders less than \$100 or 3% for orders over \$100 or 10% outside U.S.A. Phone orders: We accept Visa or MC. Add \$2.00 for C.O.D. Will Call Hours 9am to 4pm.

JOHN BELL ENGINEERING, INC.



1014 CENTER ST.
SAN CARLOS, CA. 94070
(415) 592-8411

PERIPHERALS FOR THE IBM PC

look for low cost— high quality inter- faces for the IBM PC

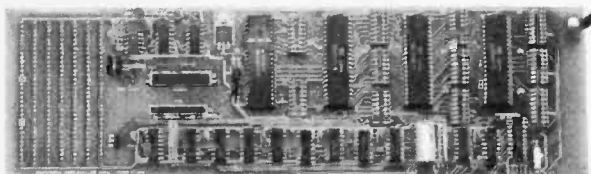

UNIVERSAL I/O. The Universal I/O board has 16 eight bit analog inputs with a voltage range of 0 to 5 volts. It also has 9 eight bit parallel I/O ports. It has interrupt circuitry, Timer clock 32768 Hz. to 512 sec., prototyping area, and LED for power. Part number 83-064A \$299.95

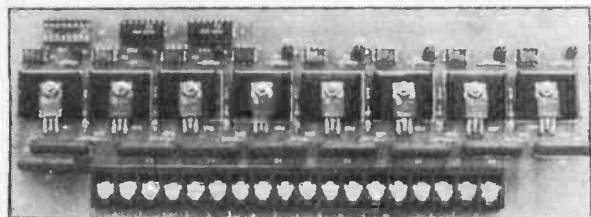

120 VAC CONTROL. This board has eight optically isolated triac switches. Each switch can control 200 watts. It connects via a 16 pin ribbon cable to a parallel output port. Screw terminals are provided for 120 vac connection. Part number 82-332. \$119.95.

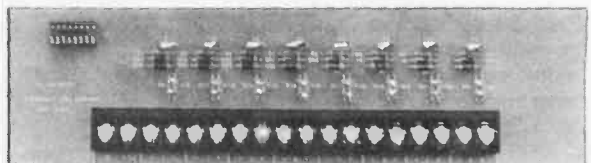

INPUT PROTECTOR. This board protects the inputs of the ANALOG input or PARALLEL input ports. There are 4.7K pullups, diodes and caps for each line. It connects via a 16 pin ribbon cable. Screw terminals are provided for connection. Part number 82-334. \$89.95.

To order: Send check or money order. Add 6.5% tax in California. Add 5% shipping for orders less than \$100 or 3% for orders over \$100 or 10% outside U.S.A. Phone orders: We accept Visa or MC. Add \$2.00 for C.O.D. Will Call Hours 9am to 4pm.

JOHN BELL ENGINEERING, INC.



1014 CENTER ST.
SAN CARLOS, CA. 94070
(415) 592-8411

PERIPHERALS FOR THE APPLE II

look for low cost— high quality inter- faces for the APPLE II

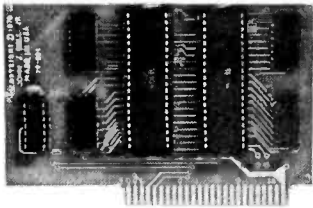

6522 APPLE II INTERFACE. This interface plugs directly into slot 1 through 7 in the APPLE II or the APPLE IIe. It provides four 8 bit bi-directional I/O ports, four 16 bit timer/counters, and handshaking. Four 16 pin dip sockets provide easy

connections to peripheral devices. This board is also used to run the JBE EPROM Programmer. Order part # 79-295A asm. \$69.95 or # 79-295B bare board \$29.95

EPROM PROGRAMMER.

Programs 5 volt 2716's, 2516's, and 2532's. It interfaces to the 6522 interface with 4 ribbon cables. A Textool zero insertion force socket is used for the EPROM. Complete documentation for reading and writing. Cables available separately. Order part # 80-244A asm. \$49.95 or # 80-244B bare board 29.95 and set of 4 cables 2 ft. long \$17.00

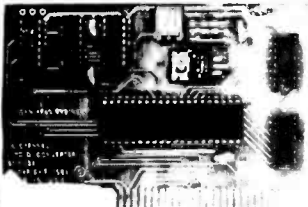
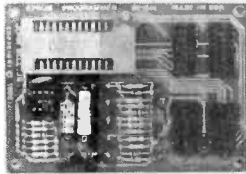

A-D CONVERTER.

16 Channel A-D plugs into your APPLE II or APPLE IIe. The 16 inputs are high impedance, 0 to 5 volt range, 8 bit resolution. Conversion time is less than 100 us per channel. Two 16 pin dip sockets are used for input.

Order part # 81-132A asm. \$89.95 or # 81-132B bare board \$29.95

SPEECH SYNTHESIZER.

This board uses the VOTRAX SC-01 Phoneme Synthesizer chip. The on board audio amp connects directly to an 8 ohm speaker. A disk with a text to speech program is included. Order part #81-088 \$129.95

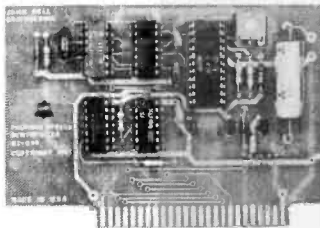

To order: Send check or money order. Add 6.5% tax in California. Add 5% shipping for orders less than \$100 or 3% for orders over \$100 or 10% outside U.S.A. Phone orders: We accept Visa or MC. Add \$2.00 for C.O.D. Will Call Hours 9am to 4pm.

JOHN BELL ENGINEERING, INC.



1014 CENTER ST.
SAN CARLOS, CA. 94070
(415) 592-8411

INDUSTRIAL CONTROL PRODUCTS

look for low cost— high quality indus- trial computers



SLIM MICROCOMPUTER. This 6502 based 4.5" x 6.5" computer has the same 44 pin bus as the AIM computer. It has 2K RAM, 2K or 4K EPROM, and four 8 bit parallel I/O ports (two 6522's). The clock is 1 MHz crystal controlled and has power on reset. This board was

designed for control and is ideal for personal and OEM use. This computer can be expanded with the peripherals listed below. Order part # 81-260A asm. \$199.95 or #81-260B bare board \$39.95

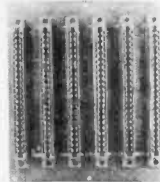

SIX SLOT MOTHER BOARD.

This board has 6 44 pin edge connectors connected in parallel. The card spacing is .750". It will mount in VECTOR card cages. Order part # 81-320A asm. \$99.95 or # 81-320B bare board \$49.95.

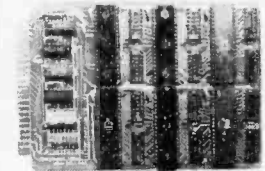

12 PORT PARALLEL I/O.

This board has six 6522 VIA's. This is a total of 96 I/O lines. Each of the 12 8 bit ports also has 2 handshake lines. Order part # 82-036A asm. \$169.95 or # 82-036B bare board \$49.95

RAM EPROM MEMORY (32K).

This board has 16 24 pin sockets that will accept 2716 EPROM's or 6116 RAM's to total 32K bytes. The memory is mapped from 0 to 7FFF. The first 2K (0-7FF) can be disabled with a jumper to allow for the 2K of RAM on the SLIM computer. Order part # 81-330A asm. w/o memory \$99.95 or # 81-330B bare board \$49.95

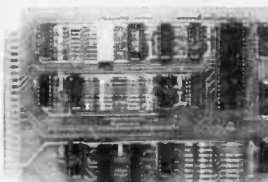
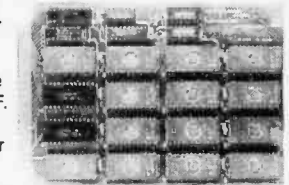

ANALOG I/O INTERFACE. This board has 16 analog inputs and 2 analog outputs. The inputs are 8 bit (256 steps), 0-5 volt, high impedance with a conversion time of 200us per channel. The outputs are R-2R ladders (R = 15K) driven between 0 and 5 volts and are 8 bit (256 steps) also. Order part # 81-292A asm. \$199.95 or #81-292B bare board \$49.95

To order: Send check or money order. Add 6.5% tax in California. Add 5% shipping for orders less than \$100 or 3% for orders over \$100 or 10% outside U.S.A. Phone orders: We accept Visa or MC. Add \$2.00 for C.O.D. Will Call Hours 9am to 4pm.

JOHN BELL ENGINEERING, INC.



1014 CENTER ST.
SAN CARLOS, CA. 94070
(415) 592-8411

MICRO SALES

★ MADE IN USA ★ BUY FACTORY DIRECT ★

DISK DRIVE SPECIALS We've Lowered Our Prices

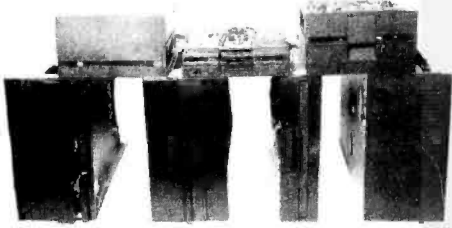

Offering A Complete Selection And THE LOWEST PRICES IN BYTE!

8" Shugart 801R SS/DD — The Industry Standard	\$355.00
8" Shugart 851R Double Sided 1.2 Meg — The Old Reliable	457.00
8" Qume Datarak-8 DS/DD "THE BEST" of the floppys	479.00
8" Mitsubishi Full Height Double Sided 1 Year Parts + Labor	445.00
8" Mitsubishi Thinline DS/DD 1 Year P+L Direct Drive	465.00
8" Tandon 848-1 Slimline SS/DD 600K BYTES D.C. Motor	355.00
8" Tandon 848-2 Slimline Double Sided 1.2 Meg. D.C. Motor	475.00
8" Siemens 100-8 SS/DD ON SALE NOW!!! But How Long?	169.00
8" Mitsubishi Full height 96T.P.I. DS/DD 750K M4852	295.00
5 1/4" Mitsubishi Slimline 96T.P.I. DS/DD 750K M4853	315.00
5 1/4" Tandon TM-100-1 SS/DD 48T.P.I. 168K Apple Apple	199.00
5 1/4" Tandon TM-100-2 I.B.M. PC Add-on! DS/DD 48 T.P.I.	259.00
5 1/4" Tandon TM 100-4 DS/DD 96T.P.I. 750K	369.00

★ WINCHESTER HARD DISKS ★

5 1/4" Miniscribe 5 Meg* Hard Disk — Affordable	\$695.00
5 1/4" Miniscribe 10 Meg* Hard Disk — Twice the Space	850.00
5 1/4" Miniscribe 16 Meg* Hard Disk — Best Buy	995.00
5 1/4" Miniscribe 10 Meg* Thinline only 1 1/2 inches wide!	795.00
8" Quantum 20" Megabyte Winchester — Two Platters	1895.00
8" Quantum 40" Meg Four Platter — Most Popular	2395.00
8" Quantum 85" Megabyte — Special Order on this Monster!	2895.00
8" IDMEGA 10- Meg* Removeable Disk Drive with SCSI Controlled Interface Board. Runs up to four drives	1895.00
8" IDMEGA 10 Meg* Cartridge Drive — No Control Interface	895.00
8" 10 Meg* Removeable Cartridge Media #M-2000-51	50.00

★LAST MINUTE SPECIAL!!! Buy any Winchester hard disk drive above and get a Western Digital hard disk interface board AT COST! ONLY 295.00!

*Total storage space after formatting.

California Computer Systems

CCS SYSTEM 2410 . . \$1995.00

- ★ Includes CP/M® 2.2
- ★ 2-Serial/1-Parallel Port
- ★ DMA Disk Controller
- ★ Hardware Vectored Interrupts
- ★ 2-Real Time Clocks
- ★ Supports CP/M®, MP/M®, OASIS

CCS 2300 System, A & T . . \$1695.00

- ★ Includes CP/M® 2.2
- ★ New 2066 64K Memory
- ★ 2300 Mainframe 10 Slot M/B
- ★ 2422 Disk Controller
- ★ 2810 Z-80A CPU @ 4MHZ
- ★ Complete A+T

★ 2710 4 Port Serial RS-232	\$245.00
★ 2719 2 Serial — 2 Parallel Centronics	245.00
★ 2810 CPU Z-80 at 4 MHz In Stock	Only—255.00
★ 2422 Disk Controller with CP/M 2.2	Only—330.00
★ 2066 64K Dynamic Memory	Only—360.00
★ 2300A Mainframe Assem. + Tested	Only—455.00
★ CCS Apple Boards	Call Toll Free For Prices

8" POWER
For Two 8" Floppys

+5VDC @ 4 Amps
+24VDC @ 3 Amps
-5VDC @ 1 Amp

ONLY 59.95

S-100 POWER
For 6 to 22 Slots

+8VDC @ 30 Amps
+16VDC @ 6 Amps
-16VDC @ 6 Amps

ONLY 89.50

★ UNIVERSAL POWER SUPPLY . . . 69.95

HAYES SMARTMODEM 1200 THE LEADER OF THE HAYES MODEM FAMILY

- 1200 Baud — Bell 212A Compatible
- 300 Baud — Bell 103 Compatible
- Automatic Dialing — Touchtone or Pulse
- Automatic Send, Receive and Disconnect
- Built-in Speaker for Monitoring Call Line

These are just a few features of the Smartmodem 1200, the best modem you can buy. In fact, it performs just about any communication function you can imagine, and can be program controlled using any language. Our special price . . . \$549.00

★ Make things easy for yourself. Get the Hayes Smartmodem 1200 with-CROSSTALK™ software . . . \$695.00

FANTASTIC SAVINGS!

\$395
HELD OVER

ON THE ORIGINAL S-100 MOD

For engineers, hobbyists, and anyone who wants to save a bundle, the S1-MOD is the answer. Full regulated power to run up to four floppy disks coupled with a mammoth S-100 power supply and 12 slot bus, makes the S1-MOD an exceptional computer base. Single board design means no wiring from the power supply to the motherboard. This eliminates all ground loop problems associated with other brands of mainframes who are forced to use termination. The S1-MOD is being offered this month with a matching S-100-12 cabinet. Fan cooled, fused, with reset and keylock the cabinet is also enamel painted and silk screened. Four A.C. outlets are provided for peripheral hookup and plenty of cutouts available for RS-232, centronics + others. Our regular \$225.00 price for the S1-MOD and 250.00 price for our 12 slot cabinet is being SLASHED!

SPECIFICATIONS:
Regulated Unregulated
+5V @ 5A +8V @ 30A
+24V @ 3A +16V @ 6A
-5V @ 1A -16V @ 6A

Don't settle for those cheap 6 slot imitations you've seen elsewhere in the mag. OWN THE BEST! XOR S-1 MOD and S-100-12 Cabinet . . . \$395.00

DUAL DRIVE SUBSYSTEMS



HORIZONTAL OR VERTICAL
Fully Assembled and Tested Units
ONE YEAR P+L WARRANTY
On Shugart and Mitsubishi Subsystems

w/two Mitsubishi DS/DD Assem. + Tested 2.4 Meg	\$1170.00
w/two Shugart 801R SS/DD Assem. + Tested 1.2 Meg	975.00
w/two Shugart 851R DS/DD Assem. + Tested 2.4 Meg	1225.00
w/two Siemens 120-8 SS/DD Assem. + Tested 1.2 Meg	675.00
w/two Qume DT-8 DS/DD Assem. + Tested 2.4 Meg	1250.00
Cabinet Assem. & Tested w/Power Supply and Accs.	235.00
Cabinet Top and Bottom with Mounting Hardware	Only 69.50
All cabinets A & T and subsystems include all AC/DC wiring and 50 pin data cable except the horizontal models which include the Internal 50 pin cable and requires an external 50 pin cable part #C-6000-01	\$ 25.00

5 1/4" Subsystems — Cabinet — Power Supply — Drives — Cables	
w/two 48TPI SS/DD includes all cables Assem. + Tested	495.00
w/two 48TPI DS/DD includes all cables Assem. + Tested	595.00
#M-2000-10 parallel w/tractor	\$599.00
#M-2000-83 serial w/tractor	\$699.00

CUSTOMER SERVICE HOTLINE 1 - (714) 898-5525

DRIVE CABINET DEALS



STILL ON SALE!

On assembled and tested cabinets.

One year parts and labor on these dual drive cabinets, complete with power supplies, A.C. and D.C. cables, 50 pin data cables (vertical only) and complete mounting hardware.

#S-1000-05 SALE	\$199.00
50 pin data cable for horizontal cabinet #C-6000-01	\$ 25.00
vertical cabinet complete w/50 pin data cable #S-1000-13 SALE	\$199.00
5 1/4" vertical cabinet complete with 34 pin data cable #S-1000-20 SALE	\$129.00

BARE CABINETS!

Horizontal or vertical types, we'll even supply mounting hardware. Cabinets are enamel painted a beautiful tan texture and have mounting holes available for fan, drives, A.C. cable, power supply, etc.

Horizontal 8" Empty w/Hardware	\$59.95
Vertical 8" Empty w/Hardware	\$55.00

★ The fifty-five dollar ★ 8" Power Supply is Back!

Specifications:
For 2 8" Floppys
+5 V.D.C. @ 4 Amps
+24 V.D.C. @ 3 Amps
-5 V.D.C. @ 1 Amp

Perfect for do it yourself applications. Will run at 120V/50 Hz or 230V/50 Hz. All power supplies include D.C. cables and schematic.

8" Power Supply #U-1000-02	\$55.00
SS/DD A.C. Harness #C-6000-37	\$ 7.50
DS/DD A.C. Harness #C-6000-38	\$ 7.50

PERIPHERAL SPECIALS

XOR 500 TERMINAL SALE!
\$495.00

XOR 500: A new video display terminal featuring
★ Screen Illt ★ Detached keyboard ★ 9 cursor control keys ★ 5 function keys ★ 7 screen attributes ★ 25th status line ★ 50-19.2K baud ★ Column + filed tab ★ and more ★ All these features with a full 6 month warranty make this terminal the best buy on the market. RS-232 cable not included.
XOR 500 #T-1000-15 . . . \$495.00

5 1/4" MITSUBISHI

5 1/4" Half Height Floppys. 48 or 96 T.P.I. These double sided, double density drives will hold 5 and 1 megabytes unformatted — full one year parts and labor warranty. The 48 T.P.I. drives are perfect for I.B.M. P.C. add-ons!
#D-1000-34 DS/DD 48 T.P.I. Thinline . . . \$295.00
#D-1000-32 DS/DD 96 T.P.I. Thinline . . . \$315.00

OKIDATA ML92

Okidata Microline. New versatility, correspondence quality printing and speed make the ML92 and ML93 the best printer values in their categories. Both printers provide multi-speed print modes; bi-directional high speed mode with short line seeking logic at 160cps, emphasized and enhanced mode printing at 80cps, and high resolution correspondence quality printing at 40cps. Dot-addressable graphics is standard. Both serial and parallel models are available and BOTH prices include full tractor assembly at no extra charge.
#M-2000-10 parallel w/tractor . . . \$599.00
#M-2000-83 serial w/tractor . . . \$699.00

PMMI S-100 MODEMS

2 models are now available. The highly popular MM103 which is Bell 103A @ 300 baud, also runs at 600 baud, and the new modem from PMMI which is Bell 103A and 212 compatible at 300 and 1200 baud, auto answer auto dial IEEE 696 standard. If software is a problem, we've got it! Designed specifically for the PMMI
#M-2000-45 300-600 baud . . . \$349.00
#M-2000-44 300-1200 baud . . . \$595.00
#B-1001-16 Crosstalk Software . . . \$150.00



TWO Locations to Serve You

ORDER TOLL FREE

☆ EAST ☆

☆ WEST ☆

1 (800) 435-9357 1 (800) 854-8174

In Ill. (815) 485-4002

In Calif. 1 (714) 898-1492



MICRO SALES

★ MADE IN USA ★ BUY FACTORY DIRECT ★

★ EAST ★ 11 Edison Drive, New Lenox, Illinois 60451
★ WEST ★ 15392 Assembly Lane, Huntington Beach, CA 92649

TERMS: We accept VISA/MC, prepay, check or money order. Please allow personal check two weeks to clear before shipment. \$5.00 handling charge on all orders under \$50.00. 15% Restocking Fee. All orders shipped via U.P.S. unless otherwise specified. All UPS C.O.D. orders over \$100.00 require a Cashiers Check. ★ Our products carry a full 6 months parts and labor warranty excluding drives, printers and terminals which carry the full O.E.M. factory warranty. PRICES SUBJECT TO CHANGE WITHOUT NOTICE.

CUSTOM COMPUTER SYSTEMS by XOR

Why do companies like I.B.M. Corp., Atari Corp., Mattel Elec., Kennedy Space Center, Edwards A.F.B., Motorola Corp., Raytheon, and Pacific Technology buy product by mail from us? Maybe it's our full 1 year parts and labor warranty on all XOR O.E.M. products. It could be our state of the art technology, or even the factory direct sales and service. We think it's our custom computer systems with over 1000 possible configurations. If you don't see it advertised, call us today, chances are we CAN custom build the system YOU need.

★ MICRO MANAGERS: POWERFUL, PORTABLE, AND AFFORDABLE ★

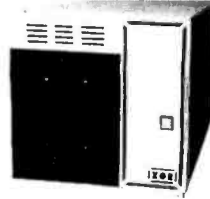

Don't be fooled by the system's small portable size. A full 64K of memory with an industry standard S-100 bus. Includes CP/M 2.2 and many utilities on two disks. Add on a hard disk when you need more storage. The software and hardware that comes with each 5 1/4" system is ready to run a pair of 8" single or double sided floppies, just plug in the 50 pin data cable to the system — many other configurations are available.



Inexpensive but powerful, small enough for portability, these mini hard disk systems have a special XOR Interface to the S-100 bus that leaves an S-100 slot open for expandability. Choose from 5, 10, and 16 megabyte sizes (6.5, 12, + 20 megabyte unformatted.) Includes CP/M operating system. One year parts and labor warranty. Includes software and controller for 8" floppies.

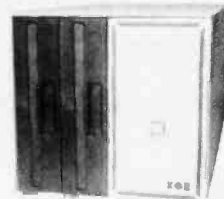

Our most popular computer features a 4 slot S-100 bus and 8" industry standard format. Reads and writes the IBM 3740 format as well as any byte size sector. Expandable? Yes, add a hard disk or cartridge subsystem when your data base grows. You've probably seen some "look-a-like" S-100 4-slot systems lately, but they just don't measure up the XOR 8" Micro Manager

5 1/4" Z-80A 64K CP/M System

- ★ Dual Floppy 375K SS/DD 40 Track #S-1000-85 \$1445.00
- ★ Dual Floppy 750K DS/DD 40 Track #S-1000-87 \$1595.00
- ★ Dual Floppy 1.5 Meg DS/DD 80 Track #S-1000-88 \$1645.00
- ★ System Chassis (No boards, drives, CP/M) #S-1000-84 \$ 425.00

5 1/4" Hard Disk with 1/2 Height Floppies

- ★ 5 Meg Hard Disk w/375 Floppy #S-1000-81 \$2195.00
- ★ 5 Meg Hard Disk w/750K Floppy #S-1000-90 \$2345.00
- ★ 10 Meg Hard Disk w/2 1.5M Floppy #S-1000-92 \$2795.00
- ★ 16 Meg Hard Disk w/2 1.5M Floppy #S-1000-93 \$2895.00

2.4 Meg DS/DD 8" CP/M System

- ★ System w/Dual SS/DD 1.2 Meg #S-1000-40 \$1795.00
- ★ System w/Dual DS/DD 2.4 Meg #S-1000-39 \$1995.00
- ★ System w/NO Drives (Includes CP/M) #S-1000-71 \$1195.00
- ★ System Chassis (No boards, drives, CP/M) #S-1000-70 \$ 395.00

★ THE BASIC PROFESSIONAL FLOPPY, HARD DISK AND TAPE BACKUP ★

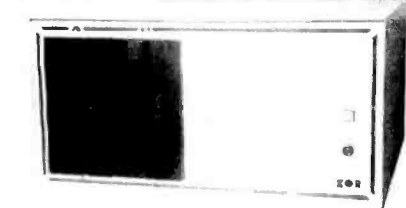

2.4 Meg DS/DD 64K Z-80A CP/M System
This industry standard computer features a 12 slot motherboard, 30 amp power supply, 2 serial RS-232 ports, centronics parallel port and CP/M software. The XOR disk controller included, will read and write the IBM 3740 format (8" CP/M standard) as well as R/W single or double sided, single or double density, and any byte/size sector. One year parts and labor on the complete system. #S-1000-36 \$2345.00

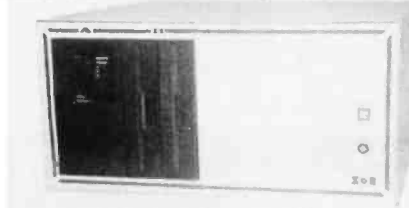

20 Meg Winchester w/2.4 Meg Floppies
For the serious professional this system features the famous S-100-12 cabinet with XOR's S1-MOD 12-slot motherboard. The Quantum hard disk has two 10 Meg platters (A; and B). One platter can be "backed-up" on another. 2/DS/DD 1.2 floppies are used for software entry, copies, and back-up. One year parts and labor. #S-1000-63 \$5275.00

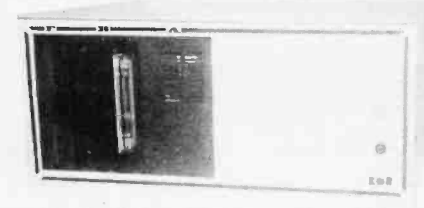

20M H.D. with 17M Tape and 1.2M Floppy
Backup your precious data on this full 17 megabyte tape drive and be able to plug files between any of the three peripherals for total versatility. Boot CP/M from hard disk or floppy, change tapes for archival storage. Reads and writes the IBM 3740 Format (8" CP/M standard). #S-1000-69 \$6390.00
Above system 40 megabyte hard disk #S-1000-82 \$7825.00

CP/M 3.0

U.S. MICRO SALES SOFTWARE GIVEAWAY!

CP/M 3.0

FREE

Order any system below and get all of the following software and manuals absolutely FREE! CP/M Operating System, Perfect Writer, Perfect Speller, Perfect Mailer, Perfect Calc, AND an eight module business accounting package by BUSINESSMASTER INCLUDING: A/R order entry, A/P purchase orders, G/L, Payroll, Mailing List, Fixed Asset Accounting, Inventory (RAW), and inventory regular goods. AND multi-user systems also include Digital Research's MP/M and Link-80 software. \$1685.00 value.

FREE

★ THE OFFICE MASTERS! REMOVABLE CARTRIDGE DISK SYSTEMS ★

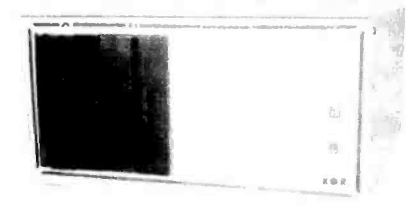

10 Meg Cartridge Disk And 1.2 Meg Floppy
An office system at an almost unbelievable price when you consider the bundle of applications software that comes with the system. Ten megabytes of formatted storage on a removable cartridge disk allows unlimited storage space with extra 10 Meg cartridges available at \$50.00 each. With the speed and reliability of a hard disk and removability of a floppy this office master is the choice. #S-1000-74 \$3695.00

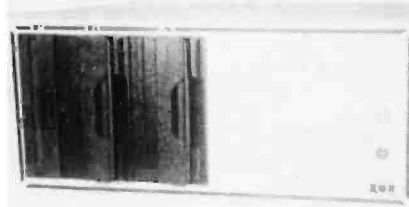

TWO 10 Meg Removable and DS/DD Floppy
Destined to be our #1 seller and no one else makes anything like it. A true state-of-the-art system with virtually unlimited storage capacities in 10 Meg removable cartridges. Backup problems? Get high speed backup from cartridge to cartridge, ten megabytes worth, in 6 minutes! HINT: We don't use "PIP". Future technology here today. #S-1000-76 \$4595.00

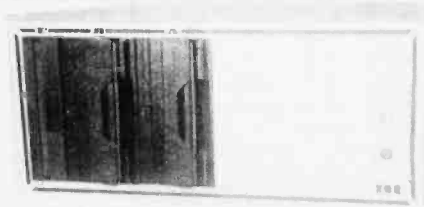

Multi-User Cartridge Disk System
Four users and two 10 megabyte removable cartridge disks may be just what you want to automate your office or small business, with all the software packages you'll ever need. A multi-user version of the system at left, these users can be up to 100 feet away from each other. Most any terminal will work with the user ports. #S-1000-80 \$5825.00

★ THE BUSINESS PROFESSIONALS: HARD DISK MULTI-USER SYSTEMS ★

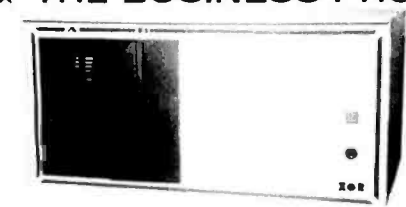

2 User Hard Disk System
A twenty meg hard disk (2 platter) with a DS/DD 1.2 Meg floppy disk makes this a perfect system for a small business. Two user allows dual access to the system files with each station up to 100 feet apart! Includes above software. Full one year parts and labor. #S-1000-61 \$5495.00

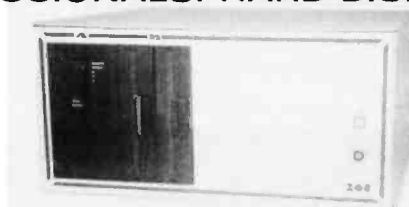

40 Meg Hard Disk 4 User System
A must for a growing business! Two DS/DD floppies (2.4 Meg) for data backup and copy with a 4 platter 40 Meg hard disk four user capability to automate the whole front office. You can even designate a 10 Meg platter to each user! Same warranty as all our products — (configurable from 2 to 7 users) #S-1000-60 \$7295



7 User 85 Meg w/17 Meg Backup
Now it's available, the automated business system to run even those large companies! 7 separate users tied into one professional host system. If 85 Meg isn't enough, we can put together as much as three hundred and forty megabytes! Full 17 Meg tape backup insures archival storage of valuable data #S-1000-98 \$9595.00



LET US CUT YOU A DEAL!

MINIMUM SHIPPING \$3.00 - NO SURCHARGE ON VISA/MASTERCARD

1-800-545-2633 - Continental U.S.

DISK DRIVES

SHUGART

5 1/4" SA400(35-TR) 160K	150.00
5 1/4" SA400L (40 TR) 190 K	175.00
5 1/4" SA455L (40 TR) 320 K 1/2 HGT	235.00
8" SA801R(SS/DD) 1.2 MG	359.00
8" SA851R(DS/DD) 2.4 MG	479.00

QUME

5 1/4" 142 (40TR) 320 K 1/2 HGT	240.00
8" DT8 (842)	490.00

MITSUBISHI

5 1/4" M-4853 1/2 size	410.00
96 TPI same as TM 100-4	
5 1/4" M-4854 1/2 size	439.00
1.6 MG w/B "electronics formats same as IBM 1 & 2D 8" sid	

8" M-2894-63 (110V)	399.00
STD 8" DS/DD 1.2 MG	

M-2894-63(SS/DD) 220V	449.00
8" M-2996-63	439.00
Thinline 8" DS/DD 1.2 MG	

DISKETTE STORAGE

ADVANCE ACCESS

AA-5 1/4 (Holds 82 Disks)	17.00
AA-8 (Holds 82 Disks)	26.00
Smoked Plexiglass Disk Tubs	

LIBRARY CASES

CAS-5 1/4"	2.50
CAS-8"	3.00
Color Burst (Pack of 5)	12.00
Colors Available; color burst asst., beige, black, blue, red, gray	

DATA CABLES

8"DSC 88-2SKT-for 2-8" drvs w/skt. conn.	20.00
5 1/4"DSC55-2SKT-for 1-5 1/4" drvs w/skt. conn.	20.00
RS232MM-5 (male to male)	19.00
IBM to PAR	32.00
Osborne to PAR	32.00
Kaypro to PAR	32.00
OKI-Data Serial	24.00

E-PROM ERASERS

QUV-T8/1 (hobby)	49.95
QUV-T8/2 (Industrial version)	68.95
QUV-T8/2 (w/timer & safety switch)	97.50

REMAX

5 1/4" RFD 480-DS/DD (For IBM-PC)	235.00
-----------------------------------	--------

TANDON

5 1/4" TM100-1 SS/DD 160K	150.00
5 1/4" TM100-2A FOR IBM-PC DS/DD (320 K)	239.00
8" TM848-2 (DS/DD) 1.2 MG	450.00

PERTEC

5 1/4" FD200-5 160 K	139.00
SS/DD 40TR	
5 1/4" FD250-5 320 K	195.00
DS/DD 40TR	

SIEMAN'S

8" FD100-8 (SS/DD) 110V 801 R	179.00
8" FD100-8 (SS/DD) 220V Compatible	199.00

MPI

5 1/4" B-51 40TR SS/DD 180 K	145.00
------------------------------	--------

CONNECTORS

RS232 Connectors

SOLDER TYPE	
DB25P	2.50
DB25S	3.00
DB25 Hood	1.00
S-100 Connectors	10 for 25.00
DE9P	2.00

FLAT RIBBON TYPE

IDC25P	6.25
IDC25S	6.60
IDC25 Hood	1.60

SOCKET

Qty. 100	
IDC10SKT1.90	1.00
IDC16SKT2.50	1.20
IDC34SKT4.50	2.20
IDC20SKT2.75	1.30
IDC50SKT6.50	3.20

CARD EDGE

Qty. 100	
CEC26	5.00
CEC50	7.25
CEC34	6.00
	3.50

MODEMS

Anchor	89.00
Hayes Smart 300	199.00
Hayes Smart 1200	499.00
Multi-Tech MT 212 AD (1200/300)	499.00
Novation J-Cat 300	119.00
Novation Apple Cat	269.00
SSM AMC-300 (For Apple)	
Auto Dial	259.00
U.S. Robotics 212A Auto Dial	469.00

DISK DRIVE CABINETS

8" CABINETS

8" DDC88V28 w/PS vertical for 2-8" drives	300.00
8" DDC88T-1 w/PS vertical-for 2 or 4-8" thinline drives	300.00
8" DDC88T-2 w/PS vertical for 2 8" thinline drives	225.00
8" DDC8H w/PS horizontal for 1 ea. 8" drive	249.00
8" DDC8V w/PS vertical for 1 8" drive	249.00
8" DDC88H w/PS horizontal for 2-8" drives	300.00

5 1/4" CABINETS

5 1/4" DDC5H w/PS horizontal-for 1-5 1/4" drive	59.00
5 1/4" DDC5V w/PS vertical-for 1 ea. 5 1/4" drive	65.00
5 1/4" DDC55V w/PS vertical-for 2-5 1/4" drives	89.00

DISK SUB ASSEMBLY

OUR BEST BUY'S

8" SUB ASSEMBLY

DDS + 0 2EA SS/DD Siemens FD100-8 Drives w/Cabinet	595.00
DDS + 2 2EA DS/DD Mitsubishi M2894-63 w/cabinet	1,075.00
DDS + 4 2EA DS/DD 8" Thinline Drives w/Cabinet	1,150.00
Specify—Vertical or Horizontal Cabinet	

5 1/4" SUB ASSEMBLY

DDS + 5 1EA SS/DD Disk Drive	200.00
DDS + 6 2EA SS/DD Disk Drive	369.00

PARTS

TR1602B	2.50 ea.	TMS2716 (5+ 12V)	\$3.95 ea.
2114L2	\$1.50 ea.	TMS2732	\$4.95 ea.
TMS2532	\$5.95 ea.	TMS4164	
2716 (5V)	\$3.95 ea.	(200NS)	\$5.95 ea.
		TMS116-4 (200NS)	\$4.75 ea.

MANY OTHERS IN STOCK

VIDEO DISPLAY MONITORS

GREEN

BMC 12AU (15 MHZ) 80 Col/12"	80.00
Dynax GM 120 (20 MHZ) Hi-Res/80 Col/12"	129.00
Sanyo DM 2112 (15 MHZ) 64 Col/12"	80.00
Sakata SC-1000 (18 MHZ) 80 Col/12"	119.00
USI PI-1 (20 MHZ) Hi-Res/9"	129.00
USI PI-2 (20 MHZ) Hi-Res/12"	139.00

Zenith ZM121 (18 MHZ) Hi-Res/80 Col/12" 94.00

AMBER

Dynax AM121 (20 MHZ) Hi-Res/80 Col/12"	139.00
USI PI-4 (20 MHZ) Hi-Res/80 Col/9"	139.00
USI PI-3 (20 MHZ) Hi-Res/80 Col/12"	149.00

COLOR

Amdek I-12" Composite (For Apple)	260.00
Amdek II-12"-RGB (For IBM-PC) w/audio	469.00
Amdek I + Composite w/audio	289.00
BMC 9191-12" Composite (For Apple)	255.00
Princeton HX-12-RGB (For IBM-PC)	489.00
Sakata SC-100-13" Composite (For All)	260.00
Sakata SC-200-RGB (For All)	489.00

DISKETTES

COLOR CODE YOUR FILES

Disquettes by 3M with lifetime warranty. 5 colors. Prices are for package of 10.

5 1/4" Sgl side/dbl den	21.00/10
5 1/4" Dbl side/dbl den	28.00/10
5 1/4" 10 sector	22.00/10
5 1/4" 16 sector	22.00/10
8" Sgl side/dbl den	29.00/10
8" Dbl side/dbl den	39.00/10

S-100 PRODUCTS

CARD CAGES/MOTHER BOARDS

*IEEE-696-No termination required w/card bare card

Slots	Bare Bd	A + T	cage	bare card
4	15.00	40.00	60.00	20.00
6	20.00	48.00	70.00	22.00
8	25.00	69.00	100.00	31.00
12	30.00	99.00	140.00	41.00
18	45.00	150.00	200.00	50.00
22	60.00	185.00	—	75.00

All card cages will accommodate a 4" fan
Add \$20.00 for 1 fan-Add \$30.00 for 2 fans

CLOCK/CALENDAR

S-100 Clock/Calendar by QT/ Computime CCS-BB Bare Bd.	45.00
CCS-A Assembled and Tested	\$95.00

MAINFRAMES

For 2 Standard 8" Drives

MF + DD6 (6 slot M/B)	530.00
MF + DD8 (8 slot M/B)	595.00
MF + DD12 (12 slot M/B)	625.00

For 2 Thinline 8" Drives

IMF + DD6C (Cadillac version)	500.00
IMF + DD6F (Ford version)	350.00

For 2-5 1/4" Disk Drives

MF + MD12 (12 slot M/B)	560.00
-------------------------	--------

Standard Plain Front

MF + 12 (12 slot M/B)	469.00
MF + 22 (22 slot M/B)	530.00

All mainframes except IMF + DD6F have EMI filter, 2 AC outlets, 1 ea. DB25, 2 ea. 50 pin, 2 ea. 34 pin, 1 ea. Centronic cutouts, power supply for 8" MF
(- 5V1A/ + 5V6A/ + 8V16A/ ± 16V3A/ + 24V6A)

CPU/MEM/I/O

QTC-SBC 2/48B 1 ser 1 par CPU	\$50.00
QTC-SBC 2/4 A + T	\$265.00
QTC-Z + 80 B/1 serial	\$28.00
QTC-EXP + III Bare Bd. (dynamic)	\$65.00
QTC-EXP + III 64K A + T (64K/256K or 1 MEG)	\$450.00
I/O Tech I/O + 2 Ser 3 Par Bare Bd.	75.00
I/O Tech I/O + 2 Ser 3 Par A + T	300.00
I/O Tech ADA Converter	400.00
I/O Tech Dual GP1B Interface	400.00
I/O Tech S-Ram 128K Static 16 bit	795.00

SEE AD IN BYTE

COMPUPRO

S-100-all assembled and tested

System 816A	4,000.00
20 Slot MB	210.00
CPU 8085/88	389.00
Disk I w/CPM	399.00
Disk II	610.00
Ram 17-64K	410.00
Ram 21-128K	900.00
Ram 16	400.00
System Support I	350.00
Interface/4R MSP	350.00
CPU 8086/8087	599.00
Active Terminator	50.00
Enclosure 2 (desk)	675.00

CALL FOR OTHERS

SIERRA DATA

SDS-SBC-100-Z80(4mhz) master 2 serial 2 par/floppy controller/64k ram	\$675.00
SDS-SBC-100S-4mhz slave/2 serial 2 par/64k ram	\$625.00
SDS-ZSIO/4-4 serial port I/O bd	\$250.00
SDS-MUX-RS232 multiplexer bd	\$235.00
SDS-HDI-M-Hard disk bd for micropolis	\$129.00
SDS-CPM/B105-cpim for SBC 100 w/BIOS	\$150.00
SDS-Turbodos-Multi-user for master & slaves	\$645.00

BARE BOARD SET

Best Bare Board Set Available

SBC 2/4 CPU (1 SER 1-PAR)
EXP + III 256 K Memory Bd. Exp. to 1 MEG
FDC 5/8 Floppy disk controller

Bare Board Set \$150.00

- 1) Includes manuals & assembly instructions
- 2) Parts available
- 3) Monitor & B10S available. Add \$30.00.



FREE DISKETTE WITH EVERY ORDER OVER \$35.00



The Great Salt Lake Computer Company, Inc.

1-801-363-3314



TOLL FREE 1-800-545-2633 CONTINENTAL U.S.

Circle 198 on inquiry card.

LET US CUT YOU A DEAL!

CALIFORNIA RESIDENTS SAVE 6% SALES TAX

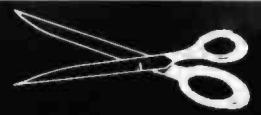

3 YEARS (1976) EXPERIENCE IN COMPUTER MAIL ORDER BUSINESS

PRINTERS

BROTHER

HR-1A Par-17CPS Daisy Wheel	695.00
HR-1A Serial-17CPS Daisy Wheel	785.00

DAISYWRITER

Daisywriter 2000-16K Buffer/40CPS LTR/Par	995.00
Daisywriter 2000-48K Buffer/40CPS LTR/Par	1,050.00
Daisywriter Cable	45.00

DIABLO

620 (25CPS/Serial)	940.00
630 (40CPS/Multi-I/F)	1,899.00

DYNAX

Dynax-15 Par-13CPS Daisy Wheel	
2 color PTG-3x buff	475.00
Dynax 15 Serial-13CPS Daisy Wheel	525.00

C, ITOH

Gorilla (Par 50 CPS)	209.00
Pro-writer I (8510A) Par 120 CPS	365.00
Pro-writer I (8510A) Serial 120 CPS	529.00
Pro-writer II Parallel-15"	669.00
8600 (180CPS) Par or Serial 18 PIN 90 CPS LTR	1,099.00
F-10 40CPS/Diablo/Par or Serial	1,149.00
F-10 55CPS/Diablo/Par or Serial	1,425.00

EPSON — CALL JUKI

6100-18CPS/Diablo Compatible Par/Daisy Wheel	539.00
--	--------

MANNESMAN-TALLY

160L (160CPS/40CPS LTR 10")	569.00
180L (160CPS/40CPS LTR 15")	785.00

MPI

MPI-99G (9") Par	499.00
MPI 150 BI (15") Par 2K Buff	
w/Graphics	675.00
MPI 150 AI (15") Par 4K Buff	
w/Graphics	799.00
MPI 150 AI (15") Par 16K Buff	
w/Graphics	899.00

NEC

NEC7715 (w/Diablo Emulation)	2,025.00
NEC8023A (100CPS-Par-Graphics)	393.00
Serial Card	139.00

OKI-DATA

Microline 82A (SER & PAR-120CPS 10")	389.00
Microline 83A (SER & PAR-120CPS 15")	629.00
Microline 92 (PAR-160CPS-LTR-10")	529.00
Microline 93 (PAR-160CPS-LTR-15")	899.00
Microline 84P (PAR-200CPS-LTR-15")	969.00
Microline 84S (SER-200CPS-LTR-15")	1,059.00

STAR MICRONICS

Gemini 10X NEW VERSION (PAR-120CPS-10")	★ 299.00
Gemini 15X (PAR-120CPS-15")	425.00
Gemini 15- (PAR-100CPS-15")	★ 399.00

SILVER REED

EXP 550P-17CPS Daisy Wheel-PAR	670.00
EXP 550S-17CPS Daisy Wheel-Serial	690.00

TOSHIBA

P-1350 (192CPS-120CPS/LTR PAR or Serial)	1,475.00
--	----------

COMPLETE LINE OF PRINTERS.

AC SURGE ELIMINATORS

Grizzly (200W) uninterruptible power system + surge protection	750.00
Grizzly (500W) uninterruptible power system + surge protection	1,802.00
Hawk AC power monitor w/surge protection	160.41
Lemon (6AC outlets-3 prong)	44.00
Lime (5-3 prong pwr cord w/on-off switch)	69.00
Orange-AC surge + EMI filter (6 outlets)	95.00
Plum - EMI-RF filter	39.00
Peach (3 outlets)	69.00

VECTREX

Complete w/9" monitor and 128K Memory \$109.00
LIGHTPEN AVAILABLE OCTOBER — CALL

IBM ACCESSORIES

AST

Combo Plus (SPC 64K)	285.00
Mega Plus (SC. 64K)	305.00
I/O Plus Serial/Par Port	149.00

D.C. HAYES

Smartmodem 1200B	469.00
------------------	--------

MAYNARD

Floppy Controller	160.00
Floppy Controller (Serial)	235.00
Floppy Controller (PAR)	215.00

MODULAR	Sandstar MOD-FDC (for 5 1/4" or 8" drives)	200.00
ADD-ONS FOR	Pararrel MOD	60.00
SANDSTAR	Serial-MOD	79.00
MOD-FDC	Clock Calendar MOD	69.00
	Game Adapter MOD	49.00

Sandstar Multi-Function BD (Holds up to 6 modular add-ons)	82.00
--	-------

QUADRAM

Quadboard 64K/256K	289.00/459.00
Quadboard II 64K/256K	289.00/459.00
Quad Link (Allows IBM PC to use Apple II Software)	589.00
Microlazer (BK)	119.00

KEYTRONICS

Enhance your PC-with a superior keyboard	195.00
--	--------

64K UPGRADE KIT — \$50.00
Includes 9 ea. 4164 (200NS)

RANA

Add-on 320K Drive	269.00
-------------------	--------

IBM Add-On Drive	
* Direct Drive * * 320 K/48 TPI	
* 5ms Track to Track *	
REMEX RFD 480	225.00

SYSTEMS

Apple II E Starter	1,625.00
Columbia PC	2,625.00
Compuro System 816A (S-100)	4,000.00
Eagle PC-2 (16BIT) 2 ea. 320 K FD/64K RAM	2,650.00
Eagle 1620	3,400.00
Eagle PC-XL	3,500.00
Franklin 1000	895.00
Franklin 1200 Starter	1,625.00
Kaypro II (w/\$2400 software)	1,495.00
PC-8801A w/software	949.00
NEC PC-8831A (5 1/4" drives)	899.00
NEC PC-8881A (8" drives)	1,525.00
Pled P1per — 1 ea. 256 K FD/64K	1,139.00
Sanyo MBC 1000 (1 ea. 720K FD/64K) 12" Mon. w/\$2000 software	1,495.00
Sanyo MBC 1000A (2 ea. 320K 1/2 HGT FD/64K) 12" Mon. w/\$2000 software	1,750.00
Televideo TS-803	1,900.00
Televideo TS-1603	2,475.00
Teletote I (new) w/software	1,695.00

TRY US FOR OTHERS

OUR SALTIEST DEALS

DISKETTES

OCTOBER—NOVEMBER SPECIAL

5 1/4" Soft Sector SS/DD	18.00/10
--------------------------	----------

FOR APPLE, ETC.

5 1/4" Soft Sector DS/DD	24.00/10
--------------------------	----------

FOR IBM PC & PARTNERS
FOR QTY OF 100 (15% DISCOUNT)

I/O PORT CONVERTER

SPC-Serial to Parallel Converter	99.00
*Allows the use of any port	
*Baud to 19.2K * Handshake Signals	
PSC-Parallel to Serial	99.00

APPLE/FRANKLIN ACCESSORIES

ALS

CPM 3.0 Card	319.00
--------------	--------

ASTAR

RF Modulator	19.00
--------------	-------

GENERIC

Disk Controller for II E	60.00
80 Column Video (Videx Compatible)	99.00

KENSINGTON

System Saver/Fan & Serge Pro	69.00
------------------------------	-------

KRAFT

Joystick for II E	52.00
-------------------	-------

MICRO-MAX

View Max 80 (80 Col for II +)	139.00
View Max 80E (80 Col w/64K Memory Exp to 128K)	149.00

MICROTEK

Dumpling 64K/Interface and Graphics 64K Buffer	235.00
Dumpling GX-PIPar Interface Card and Cable	99.00
Parallel Interface Board (RV611C)	61.00
Memory 128K	299.00
EV16 (16K Add-on Memory)	45.00

ORANGE MICRO

Grappler & Graphics Interface	121.00
Buffer Bd w/16K Buffer Exp.	139.00
Grappler + 16K Buffer Exp.	179.00

TG PRODUCTS

Joy Stick-For Apple II +	41.00
Paddles	29.00
Selecta Port	39.00

VISTA

A800 Floppy Controller for 8" Drives	300.00
A-800-1 Cable	27.00

APPLE DISK DRIVES

ALL DRIVES 1 YR. WARRANTY

Interface Corp. (40TR)	209.00
Micro-Sci A-2 (35TR)	225.00
Micro-Sci A-40 (40TR)	269.00
Micro-Sci A-70 (Quad)	329.00
Micro-Sci Controller	70.00
Rana Elite I	249.00
Rana Elite II	399.00
Rana Elite III	509.00
Rana Controller	85.00
"THINLINE" 1/2 size 163K 40TR	209.00

CLONE II SYSTEM

• Fully Apple Compatible \$575.00

TERMINALS

ADDS

Viewpoint-A1 (White)	509.00
Viewpoint-A2 (Green)	539.00
Viewpoint-3A + (Green)	509.00
Viewpoint 60-Same as Televideo 925	715.00
Viewpoint 90-Same as Televideo 950 (132 Col)	925.00
Viewpoint Color	995.00

QUME

QVT-102 80 Col. Green	550.00
QVT-102 80 Col. Amber	560.00
QVT-103 80/132 Col. Green	765.00

TELEVIDEO

TV910	529.00
TV910 +	565.00
TV925	715.00
TV950	925.00
TV970	1,095.00
RG1000/TV60 Graphics Upgrade for 925/950	1,100.00

WYSE

WYSE-100	725.00
WYSE-300 (Color)	1,125.00

Retail Sales

123 East 200 South
Salt Lake City, Utah 84111

Retail Hours

Monday-Friday 10 AM to 6 PM
Saturday 10 AM to 5 PM

Mail Orders

P.O. Box 3150
Salt Lake City, Utah 84110

Mail Orders

Monday-Friday 8 AM to 6 PM
(sometimes much later)
Saturday 10 AM to 5 PM

The Great Salt Lake
Computer Company, Inc.

1-801-363-3314

www.americanradiohistory.com

64K Static Ram

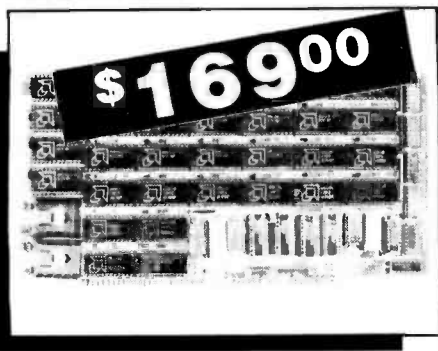

8-inch Sub-system

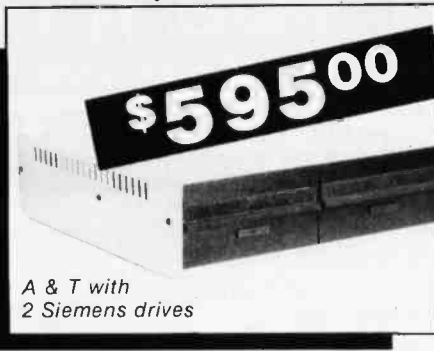

A & T with
2 Siemens drives

Siemens 8-inch



JADE Computer Products

PRICE

8-inch Slimline Sub-systems

Dual Slimline Sub-systems - JADE

Handsome vertical cabinet with scratch resistant baked enamel finish, proportionally balanced air flow system, quiet cooling fan, rugged dual drive power supply, power cables, power switch, line cord, fuse holder, cooling fan, all necessary hardware to mount two 8 inch slimline disk drives. Does not include signal cable

Dual 8 Inch Slimline Cabinet

END-000820 Bare cabinet	\$59.95
END-000822 A & T w/o drives	\$164.95

Dual 8 Inch Slimline Sub-systems

END-000843 Kit w/2 SS DD drives	\$869.00
END-000844 A & T w/2 SS DD drives	\$879.00
END-000845 Kit w/2 DS DD drives	\$1060.00
END-000846 A & T w/2 DS DD drives	\$1099.00

Dual Disk Sub-systems

Disk Sub-systems - JADE

Handsome metal cabinet with proportionally balanced air flow system, rugged dual drive power cable kit, power switch, line cord, fuse holder, cooling fan, nevermar rubber feet, all necessary hardware to mount two 8 inch disk drives, power supply, and fan, does not include signal cable

Dual 8" Sub-Assembly Cabinet

END-000420 Bare cabinet	\$49.95
END-000421 Cabinet kit	\$199.95
END-000431 A & T	\$249.95

8" Sub-Systems—Single Sided, Double Density

END-000423 Kit w/2 Siemens FD100-8Ds	\$579.00
END-000423 A & T w/2 Siemens FD100-8Ds	\$595.00
END-000433 Kit w/2 Shugart SA-801Rs	\$939.00
END-000434 A & T w/2 Shugart SA-801Rs	\$969.00

8" Sub-Systems—Double Sided, Double Density

END-000426 Kit w/2 Qume DT-8s	\$1229.00
END-000427 A & T w/2 Qume D-8s	\$1249.00
END-000436 Kit w/2 Shugart SA-851 Rs	\$1199.00
END-000434 A & T w/2 Shugart SA-851 Rs	\$1219.00

Disk Drive Power Supply

Sufficient current to power up to three 8-inch disk drives

PART NO	DESCRIPTION	1-9	10-24	24-99
PSD-206A	8" power supply	89.95	79.95	69.95

8-inch Disk Drives

Siemens FDD 100-8 Single sided, double density	
MSF-201120	\$179.00 ea 2 for \$175.00 ea
Shugart SA 801R Single sided, double density	
MSF-10801R	\$355.00 ea 2 for \$349.00 ea
Shugart SA-10851R Double sided, double density	
MSF-10851R	\$459.00 ea 2 for \$455.00 ea
Qume DT-8 Double sided, double density	
MSF-750080	\$479.00 ea 2 for \$459.00 ea
Tandon TM 848-1 Single sided, double density thin-line	
MSF-558481	\$369.00 ea 2 for \$359.00 ea
Tandon TM 848-2 Double sided, double density thin-line	
MSF-558482	\$439.00 ea 2 for \$435.00 ea
NEC FD1165 Double sided, double density thin-line	
MSF-851165	\$450.00 ea 2 for \$440.00 ea
NEC FD1164 Single sided, double density thin line	
MSF-851164	\$360.00 2 for \$350 ea

5 1/4-inch Disk Drives

Tandon TM 100-1 Single sided, double density 48 TPI	
MSM-551001	\$225.00 ea 2 for \$195.00 ea
Shugart SA 400L Single sided, double density 40 track	
MSM-104000	\$209.00 ea 2 for \$199.95 ea
Tandon TM 100-2 Double sided, double density 48 TPI	
MSM-551002	\$229.00 ea 2 for \$225.00 ea
MPI B52 Double sided, double density, 48 TPI can be substituted for CDC	
MSM-155200	\$275.00 ea 2 for \$270.00 ea
MPI B51 Single sided, double density 48 TPI	
MSM-155100	\$209.00 ea 2 for \$199.00 ea
MPI B91 Single sided, Quad density 96 TPI	
MSM-155300	\$285.00 ea 2 for \$275.00 ea
MPI B92 Double sided Quad density 96 TPI	
MSM-155400	\$400 ea 2 for \$590.00 ea

5 1/4 inch Cabinets with Power Supply

END-000216 Signal cab w/power supply	\$69.95
END-000226 Dual cab w/power supply	\$85.00

Disk Tubs

DISKETTE STORAGE BOXES

Clear Plexiglass storage boxes for up to 75 diskettes	
MMA-505 Holds 75 5 1/4" diskettes	\$19.95
MMA-508 Holds 50 8" diskettes	\$29.95

S-100 Memory Boards

64 Static Ram - JADE

Uses new 2K x 8 static RAMs, fully supports IEEE 696 24 bit extended addressing, 200ns RAMs, lower 32K or entire board phantomable, 27 16 EPROMs may be subbed for RAMs, any 2K segment of upper 8K may be disabled, low power typically less than 500ma

MEM-99152B Bare board	\$49.95
MEM-99152K Kit less RAM	\$89.95
MEM-32152K 32K kit	\$169.00
MEM-56152K 56K kit	\$225.00
MEM-64152K 64K kit	\$265.00
Assembled & Tested	add \$30.00

EXPANDORAM III

SD Systems new ExpandoRAM III is a high density S-100 memory board utilizing the new 64K x 1 dynamic RAM chips. It allows memory sizes of 64K, 128K or 256K all on a single S-100 board.

MEM-65064A 64K	\$398.95
MEM-65128A 128K	\$464.95
MEM-65192A 192K	\$524.95
MEM-65256A 256K	\$598.95

ExpandoRAM IV - SD Systems

NEW!

State-of-the-Art: full compliance with IEEE 696, 256K using 64K RAM chips. Up to 1024K using 256K RAM chips, parity check, error detection and correction optional. Supports both 8 and 16 bit data transfers. One year factory warranty

MEM-66256 ExpandoRAM IV w/parity	\$975.95
MEM-67256 ExpandoRAM IV w/EDC	\$1675.95



Surge Protection

ISOBAR

The ISOBAR looks like a standard multi-outlet power strip, but contains surge suppression circuitry and built-in noise filters, plus a 15 amp circuit breaker

EME-115105 4 receptacle	\$49.95
EME-115100 8 receptacle	\$69.95

We accept cash, checks, credit cards, or purchase orders from qualified firms and institutions.

Minimum prepaid order \$15.00 California residents add 6 1/2% tax. Export customers outside the US or Canada please add 10% to all prices. Prices and availability subject to change without notice. Shipping and handling charges via UPS Ground 50¢/lb. UPS Air \$1.00/lb. minimum charge \$3.00

Satisfying Your Personal And Professional Computer Needs Since 1975

The Big Z

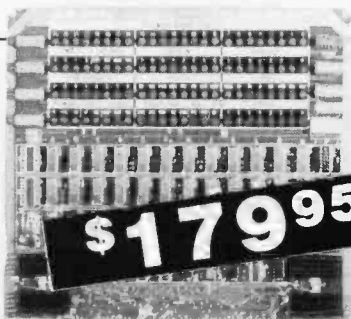
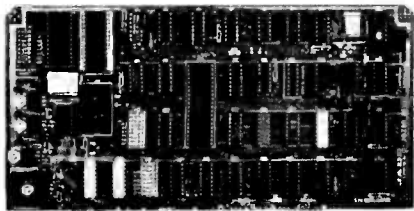

The Bus Probe

Versafloppy II

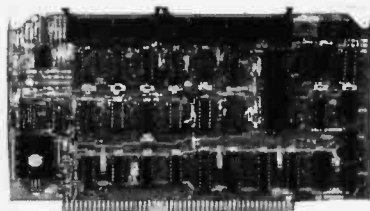

BREAKTHROUGH!

S-100 I/O Boards

The Bus Probe

Inexpensive S-100 diagnostic analyzer

TSX-200B Bare board	\$59.95
TSX-200K Kit	\$179.95
TSX-200A A & T	\$199.95

I/O-4 - SSM MICROCOMPUTER

Two serial I/O ports plus two parallel I/O ports

IOI-1010A A & T	\$245.00
-----------------	----------

I/O-5 - SSM MICROCOMPUTER

Two serial & three parallel ports. 110-19.2K baud

IOI-1015A A & T	\$289.00
-----------------	----------

Interfacer 4 - COMPUPRO

Three serial, one parallel, one Centronics parallel

IOI-1840A A & T	\$389.95
IOI-1830C CSC	\$495.00

I/O-8 - SD Systems

NEW!

Full compliance with IEEE 696 standards. Operates as a Bus Slave. Available with 8 Async ports or 4 Async and 4 Async ports. up to 1 Megabit/sec in synchronous mode. Real time clock with battery back-up. One year factory warranty

IOI-1510A 8 Async ports	\$589.95
IOI-1520A 4 Sync 4 Async	\$669.95

Eprom Erasers

Ultra-violet Eprom Erasers

Inexpensive erasers for industry or home

XME-3100 Spectronics w/o timer	\$69.50
XME-3100 Spectronics with timer	\$94.95
XME-3200 Logical Devices	\$49.95

S-100 Eprom Boards

PB-1 - SSM MICROCOMPUTER

2708, 2716 EPROM board with on-board programmer

MEM-99510K Kit w/manual	\$154.95
MEM-99510A A & T w/manual	\$219.00

Prom-100 - SD Systems

2708, 2716, 2732 EPROM programmer with software

MEM-99520A A & T with software	\$219.95
--------------------------------	----------

S-100 CPU Boards

The BIG Z — Jade

2 or 4 MHz switchable Z-80 CPU board with serial I/O accommodates 2708, 2716, or 2732 EPROM, baud rates from 75 to 9600.

CPU-30200B Bare board w/manual	\$35.00
CPU-30201K Kit w/manual	\$179.00
CPU-30201A A & T	\$199.00

SBC-200 - SD Systems

4 MHz Z-80A CPU with serial & parallel I/O. 1K RAM, 8K ROM space, monitor PROM included.

CPC-30200A A & T	\$298.95
------------------	----------

CPU-Z - COMPUPRO

2 or 4 MHz Z80A cpu. 24 bit addressing

CPU-30500A 2.4 MHz A & T	\$279.95
CPU-30500C 3.6 MHz CSC	\$374.95

8085/8088 - COMPUPRO

Both 8 & 16 bit CPUs standard 8 bit S-100 bus. up to 8 MHz. accesses 16 MegaBytes of memory

CPU-20510A 6 MHz A & T	\$389.95
CPU-20510C 6/8 MHz CSC	\$497.95

SBC 300 - SD Systems

NEW!

Self-contained S-100 Z80 microcomputer. 4/6 MHz, 64K RAM with parity, 2 to 16K of PROM, 24 bit addressing, fully complies with IEEE 696 standards. It can function as a permanent Bus Master or as Slave. Two fully programmable serial channels with handshaking; full SASI port. One year factory warranty

CPC-30304A SBC 300, 4 MHz. A & T	\$619.95
CPC-30306A SBC 300, 6 MHz. A & T	\$689.95

S-100 Motherboards

ISO Bus - JADE

Silent, simple and on sale—a better motherboard

6 Slot (5 1/4" x 8 1/2")	
MBS-061B Bare board	\$22.95
MBS-061K Kit	\$39.95
MBS-061A A & T	\$49.95

12 Slot (9 1/4" x 8 1/2")	
MBS-121B Bare board	\$34.95
MBS-121K Kit	\$69.95
MBS-121A A & T	\$89.95

18 Slot (14 1/2" x 8 1/2")	
MBS-181b Bare board	\$54.95
MBS-181K Kit	\$99.95
MBS-181A A & T	\$139.95

S-100 Disk Controllers

VERSAFLOPPY II - SD Systems

Double density disk controller for any combination of 5 1/4" and 8" single or double sided, analog phase-locked loop data separator, vectored interrupts. CP/M 2.2 & Oasis compatible control/diagnostic software PROM included.

IOD-1160A A & T with Prom	\$344.95
SFC-55009047F CP/M 3.0 with VF-II	\$80.00

2422 Disk Controller - CCS

5 1/4" or 8" double density disk controller with on-board boot loader ROM. FREE! CP/M 2.2 & manual set

IOD-1300A A & T with CP/M 2.2	\$338.00
-------------------------------	----------

Double D - JADE

High reliability double density disk controller with on-board Z-80A, auxiliary printer port. IEEE S-100 can function in multi-user Interrupt driven bus

IOD-1200B Bare board & hwdw man	\$59.95
IOD-1200K Kit w/hwdw & sltwr man	\$299.95
IOD-1200A A & T w/hwdw & sltwr man	\$325.00
SFC-59002001F CP/M 2.2 with Double D	\$99.95

Versafloppy II/696 - SD Systems

NEW!

Fully compatible with IEEE 696 standards, phase-locked loop data separator, CRC error checking. Reads/writes IBM 3740 and system 34 formats. concurrent support of any combination of 4 5 1/4" or 8" drives. Single or double sided drives supported; single or double density One year factory warranty

IOD-1170A Versafloppy II/696 A & T	\$349.95
SFC-55009157F 8" banked CP/M 3.0	**\$75.00
SFC-55009157M 5 1/4" banked CP/M 3.0	**\$75.00
SFC-55009159F 8" unbanked CP/M 3.0	**\$75.00
SFC-55009159M 5 1/4" unbanked CP/M 3.0	**\$75.00

*configured for Versafloppy II/696 & SBC 300
**price \$75.00 if ordered with Versafloppy II, price if ordered separately if \$199.95

Versafloppy III - SD Systems

NEW!

Winchester and floppy controller in a single board! Full compliance with IEEE 696 standards, controls up to three floppy drives and three 5 1/4" Winchester drives. Data may be transferred under DMA or programmed I/O control. One year factory warranty

IOD-1180A Versafloppy III A & T	\$759.95
SFC-55009257F 8" banked CP/M 3.0	**\$129.00
SFC-55009257M 5 1/4" banked CP/M 3.0	**\$129.00
SFC-55009259F 8" unbanked CP/M 3.0	**\$129.00
SFC-55009259M 5 1/4" unbanked CP/M 3.0	**\$129.00

*configured for Versafloppy III & SBC 300
**price \$129.00 if ordered with Versafloppy III, price if ordered separately \$199.95

Place Orders Toll Free!

Continental U.S.A.
(800) 421-5500

Inside California
(800) 262-1710

Los Angeles Area
(213) 973-7707

Circle 241 on inquiry card.

Disk Drive For Apple



Signalman Modem



Lowest Prices on EPROMs & RAMs

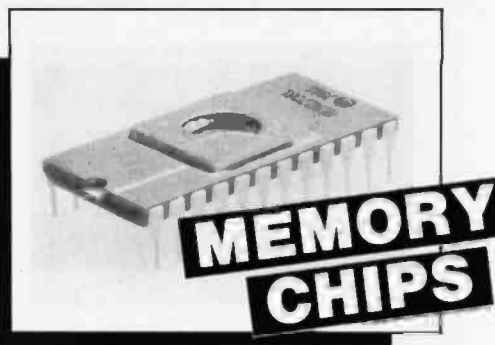

JADE

Computer Products

Apple II Accessories

Disk Drive For Apple™

Totally Apple compatible. 143,360 bytes per drive on DOS 3.3 full one year factory warranty. half-track capability reads all Apple software. plugs right into Apple controller as second drive. DOS 3.3. 3.2.1 Pascal. & CP/M compatible

MSM-431010 _____ \$199.00
MSM-431030 *Controller only* _____ \$60.00

Super Diskette SPECIAL!

We bought out a major manufacturer's overstock, and we are passing the savings on to you! Single sided, double density, package of 10

MMD-5120103 *Apple diskettes* _____ \$18.95

HALF-HEIGHT DRIVE For Apple™

Totally Apple compatible. Works with all Apple software and controllers. Faster and quieter than most other drives. yet only half the size!

MSM-581010 *half-height* _____ \$199.95

CP/M 3.0 Card For Apple™ - A.L.S.

The most powerful card available for your Apple! 6MHz Z-80B, additional 64K RAM. CP/M 3.0 plus 100% CP/M 2.2 compatibility. C basic. CP/M graphics. 300% faster than any other CP/M for Apple. One year warranty

CPX-62810A *A.L.S. CP/M card* _____ \$299.00

Z Card For Apple II™ - ALS

Two computers in one. Z-80 & 6502. more than doubles the power and potential of your Apple. includes Z-80 cpu card. CP/M 2.2 and complete manual set. Pascal compatible utilities are menu-driven. one year warranty

CPX-62800A *A & T with CP/M 2.2* _____ \$139.00

GRAPPLER PLUS - Orange Micro

The ultimate parallel printer. Graphics interface card with many new features. now at a new low price!

IOP-2300A *Grappler Plus* _____ \$119.95

FAN/POWER CENTER For Apple™

Cooling fan for your overheated Apple II, II+, or IIe; also includes power switch and two switched outlets with voltage protection circuitry

SYA-1520A *Apple fan* _____ \$59.95

80 COLUMN Apple Card

80 column x 24 line video card for Apple II addressable 25th status line. normal/inverse or high/low video. 128 ASCII characters. upper and lower case. 7 x 9 dot matrix with true descenders. CP/M. Pascal & Fortran compatible. 50/60 Hz. 40/60 column selection from keyboard. Best 80 column card!

IOV-2450A *Viewmax 80* _____ \$145.00
IOV-2455A *Preboot disk for above* _____ \$24.95

16K RAM Card For Apple II™

Expand your Apple II to 64K. use as language card. full one year warranty. Why spend \$175.00?

MEX-16700A *Save over \$115.00* _____ \$49.95

Modems

Smart Buy in Modems - SIGNALMAN

1200 and/or 300 baud. direct connect. automatic answer or originate selection. auto-answer/auto-dial on deluxe models. 9v battery allows total portability. full one year warranty

IOM-5600A *300 baud direct connect* _____ \$89.95
IOM-5610A *300 baud Deluxe* _____ \$149.95
IOM-5620A *1200/300 baud Deluxe* _____ \$369.95
IOM-5650A *300 baud for Osborne* _____ \$119.95
IOM-5630A *300 baud card for IBM* _____ \$199.95

Smartmodem - HAYES

Sophisticated direct-connect auto-answer/auto-dial modem. touch-tone or pulse dialing. RS-232C interface programmable

IOM-5500A *Smartmodem 1200* _____ \$475.00
IOM-5400A *Smartmodem 300* _____ \$199.00
IOM-1500A *Hayes Cronograph* _____ \$199.00
IOM-1100A *Micromodem 100* _____ \$349.00
IOM-2010A *Micromodem II* _____ \$259.00

1200 Baud Smart Cat - NOVATION

103/212 Smart Cat & 103 Smart Cat. 1200 & 300 baud. built-in dialer. auto re-dial if busy. auto answer/disconnect. direct connect. LED readout displays mode analog/digital loopback self tests. usable with multi-line phones

IOM-5241A *300 b 103 Smart Cat* _____ \$229.95
IOM-5251A *1200 b 212/103 Smart Cat* _____ \$549.95

J-Cat Modem - NOVATION

1/5 the size of ordinary modems. Bell 103. manual or auto-answer. automatic answer/originate. direct connect. built-in self-test. two LEDs and audio beeps provide status information

IOM-5261A *Novation J-CAT* _____ \$119.00

PRICE

Wire Wrap Sockets

PART NO	NO OF PINS	1-9	10-24	25-99	100-249
SKW-0832	8	.54	.49	.44	.40
SKW-1432	14	.64	.54	.49	.46
SKW-1632	16	.74	.64	.51	.50
SKW-1832	18	.89	.78	.74	.69
SKW-2032	20	1.09	.94	.90	.86
SKW-2232	22	1.24	1.14	1.04	.93
SKW-2432	24	1.24	1.14	1.04	.95
SKW-2832	28	1.29	1.44	1.34	1.24
SKW-4032	40	1.99	1.75	1.59	1.39

Low Profile Sockets

PART NO	NO OF PINS	1-9	10-24	25-99	100-249
SKLA-0801	8	.24	.17	.09	.07
SKL-1401	14	.24	.17	.14	.13
SKL-1601	16	.24	.19	.17	.15
SKL-1801	18	.29	.24	.21	.17
SKL-2001	20	.29	.24	.22	.19
SKL-2201	22	.34	.24	.24	.21
SKL-2401	24	.39	.29	.29	.23
SKL-2801	28	.44	.34	.34	.27
SKL-4001	40	.49	.39	.41	.39

IDC Card Edge Type Connectors

PART NO	DESCRIPTION	1-9	10-24	25-99	100-249
CNE-5102020	20 pin	2.70	2.45	3.25	2.45
CNE-5102620	26 pin	3.45	3.15	3.45	2.65
CNE-5103420	34 pin	4.45	4.15	3.45	3.45
CNE-5104020	40 pin	5.35	4.95	4.45	4.15
CNE-5105020	50 pin	6.45	5.95	5.85	4.85

IDC- Pin-Type Connectors

PART NO	DESCRIPTION	1-9	10-24	25-99	100-249
CNF-62200	20 pin	2.70	2.45	1.80	1.55
CNF-62260	26 pin	3.45	3.15	2.35	1.95
CNF-62340	34 pin	4.45	4.15	3.05	2.55
CNF-62400	40 pin	5.35	4.95	3.80	2.95
CNF-62500	50 pin	6.45	5.95	4.55	3.75

Right Angle PC Mount 50 Pin Header

PART NO	DESCRIPTION	1-9	10-24	25-99	100-249
CNM-222501	50 pin	4.25	3.55	2.95	2.40

We accept cash, checks, credit cards, or purchase orders from qualified firms and institutions.

Minimum prepaid order \$15.00 California residents add 6 1/2% tax. Export customers outside the US or Canada please add 10% to all prices. Prices and availability subject to change without notice. Shipping and handling charges via UPS Ground 50¢/lb. UPS Air \$1.00/lb. minimum charge \$3.00

Satisfying Your Personal And Professional Computer Needs Since 1975

Zero Insertion Pressure Socket

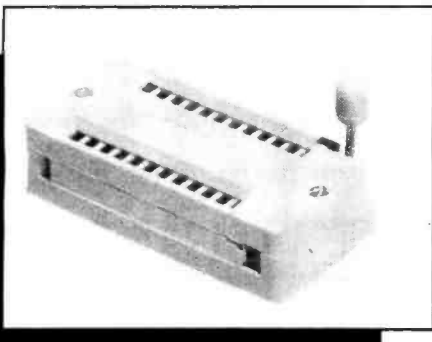

Printer Connector



RS 232 Serial Connectors

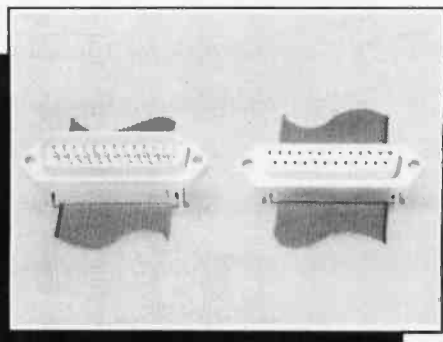

BREAKTHROUGH!



**SPECIAL PACKAGE
DB 25P, DB 25S, DB 25C**

CND-1250 RS-232 connector set _____ \$7.50

P= male/plug S female/socket C=cover/hood

PART NO	DESCRIPTION	1-9	10-24	25-99	100-249
CND-1091	DE 9P	1.95	1.55	1.40	1.30
CND-1092	DE 9S	2.70	2.35	2.00	1.80
CND-1094	DE 9C	1.45	1.20	1.05	.95
CND-1151	DA 15P	2.55	2.25	1.95	1.75
CND-1154	DA 15S	3.35	2.95	2.65	2.45
CND-1152	DA 15C	1.45	1.20	1.05	.95
CND-1251	DB 25P	2.45	2.35	2.20	1.90
CND-1252	DB 25S	3.20	3.05	3.00	2.95
CND-1253	2pc cover	1.45	1.20	1.05	.95
CND-1254	1pc cover	1.60	1.35	1.20	1.10
CND-2251	DB 25P PC MT	3.75	3.25	3.15	2.95
CND-2252	DB 25S PC MT	4.35	3.95	3.75	3.40
CND-9001	screw lock	.95	.75	.65	.55
CND-1371	DE 37P	4.45	3.95	3.55	3.25
CND-1372	DE 37S	5.95	5.35	4.75	4.25
CND-1374	DE 37C	1.70	1.45	1.30	1.15
CND-1501	DD 50P	5.90	5.30	4.70	4.20
CND-1502	DD 50S	7.90	7.15	6.45	5.95
CND-1504	DD 50C	1.95	1.70	1.45	1.25

Insulation Displacement Connectors

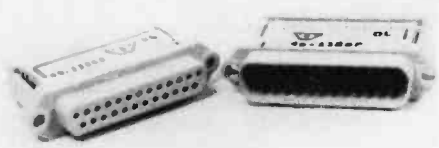

PART NO	DESCRIPTION	1-9	10-24	25-99	100-249
CND-5251	DB 25S	6.55	5.95	5.15	4.45
CND-5252	DB 25P	5.95	5.35	4.75	3.95

Centronics Type Plugs



PART NO	DESCRIPTION	1-9	10-24	25-99	100-249
CNX-236	male IDC	9.90	8.95	7.95	6.95
CNX-336	female IDC	9.45	8.75	7.75	6.75
CNX-136	male solder	8.95	7.45	5.95	5.20

RS232 Cables

Standard RS 232 Cables

All cables are 9 conductor, with pins 1 through 8 and pin 20 connected to DB25-type connectors. Fully assembled and tested including covers. Shipping weight 1 lb

WCA-1020A	Male to male, 10' long	\$24.95
WCA-1021A	Male to male, 20' long	\$29.95
WCA-1022A	Male to female, 10' long	\$29.95

Ribbon Cable

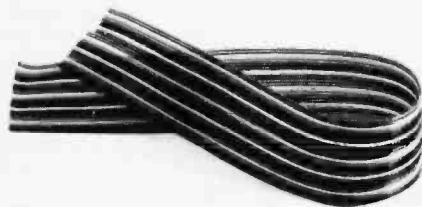

28 gauge, 7 strand Color Coded

PART NO	CONDUCTORS	PRICE
WCR-101C010	10	2.50
WCR-141C010	14	3.80
WCR-161C010	16	4.00
WCR-201C010	20	5.00
WCR-241C010	24	6.15
WCR-261C010	26	6.45
WCR-341C010	34	8.30
WCR-401C010	40	10.00
WCR-501C010	50	13.00

Zero Insertion Force Sockets

PART NO	DESCRIPTION	1-9	10-24	25-99	100-249
CNZ-1116	16 pin	5.95	5.45	4.95	4.45
CNZ-1124	24 pin	7.45	6.95	5.95	5.45
CNZ-1140	40 pin	9.95	8.95	7.95	6.45

**Memory Chips
On Sale!**

Prime Manufacturers at bargain prices
Call us for a quote on large quantities

PART NO	DESCRIPTION	PRICE
ICP-2764	64K EPROM	5.90
ICP-2732	32K EPROM	4.75
ICP-2716	16K EPROM	3.95
ICP-2716-1	16K Eprom 350ns	5.95
ICP-2758	8K Eprom	4.95
ICP-2708	8K Eprom	3.95
ICR-4164/20	64K Dynamic 200NS	5.75
ICR-4164/15	64K Dynamic 150NS	6.25
ICR-4116/20	16K Dynamic Ram 200ns	1.95
ICR-4116/15	16K Dynamic Ram 150ns	2.25
ICR-6116/20	2K x 8 Static 200NS	4.90

**Disk Drive
Signal Cables**

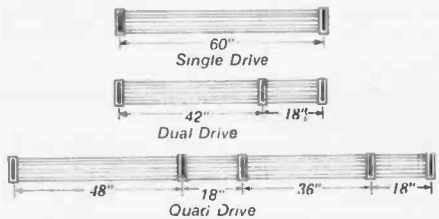

Signal cables for use with disk controllers requiring card-edge connectors

WCA-5030A	Dual 8" drive cable	\$32.50
WCA-3431A	Dual 5 1/4" drive cable	\$29.95
WCA-5050A	Quad 8" drive cable	\$39.95

Signal cables for use with disk controllers requiring pin-type connectors

WCA-3430A	Dual 5 1/4" drive cable	\$29.95
WCA-5036A	Dual 8" drive cable	\$32.50
WCA-5052A	Quad 8" drive cable	\$39.95



28 gauge, 7 strand Grey

PART NO	CONDUCTORS	PRICE
WCR-101N010	10	4.00
WCR-141N010	14	5.20
WCR-161N010	16	5.75
WCR-201N010	20	7.00
WCR-241N010	24	8.50
WCR-261N010	26	9.00
WCR-341N010	34	11.75
WCR-401N010	40	16.00
WCR-501N010	50	17.50

Place Orders Toll Free!

Continental U.S.A.
(800) 421-5500

Inside California
(800) 262-1710

Los Angeles Area
(213) 973-7707

Circle 242 on inquiry card.



\$1895

Diskettes For Apple

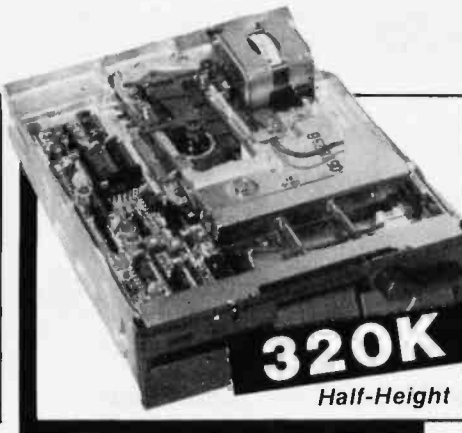

320K
Half-Height

Standard



DISK DRIVES FOR IBM PC

JADE

Computer Products

Smartmodem 1200B - HAYES

The IBM PC version of Hayes' famous Smartmodem 1200. The "B" in 1200B stands for board—this is not a bulky box that sits outside your computer, but rather a board specifically designed to plug into a PC expansion slot. Features include: direct connect, auto dial, auto answer, pulse or touch-tone dialing, and automatic baud rate selection.

The 1200B is complete with the powerful Smartcom II data communications software package, which manages file transfers and takes the hard work out of telecommunications.

IOM-5550A Smartmodem 1200B _____ \$399.00

Monte Carlo Card - MBI

Expandable from 64K to 512K, one IBM compatible centronics parallel port, clock/calendar with alarm and battery backup, dual port joystick interface. A direct connect modem which plugs on to the Monte Carlo card is scheduled to be introduced soon by MBI.

MEX-55064A 64K Monte Carlo card _____ \$395.00

320K Disk Drives for IBM PC

Double sided, double density, 320K expansion drives for your IBM PC.

MSM-991002 Standard IBM size _____ \$225.00
MSM-991004 Half-height IBM size _____ \$219.00

64K RAM Upgrades For IBM PC

High speed RAM upgrade kit with parity (error detection) and one year warranty.

MEX-64100K 64K kit for IBM PC _____ \$49.95

Vista Multicard For IBM

Memory and I/O card for your IBM PC; 64K, expandable to 256K parity checked memory, serial port (com1 or com2), parallel printer port (LPT1 or LPT2), clock/calendar with battery backup; serial interface cable included. FREE software included for clock/calendar, disk drive emulator, and printer spooler.

MEX-58064A 64K multicard _____ \$328.95

Vista PC Clock/I/O

Serial port, parallel port, clock/calendar with battery backup, parallel and serial cables included. Comes complete with FREE Dynaclock and Dynaspool support software. Compatible with PC and XT; will fit in XT's short slot.

IOK-5710A PC Clock _____ \$149.00

Vista PC Extender

One serial port, one parallel port, clock/calendar with battery backup. Includes cables and software. Field upgradable to add following options: second serial port, joystick adapter, speech synthesizer, and SCSI hard disk host adapter.

IOI-6530A PC Extender _____ \$195.00

Vista Maxicard For IBM

The ultimate in memory expansion for your IBM PC, this board is expandable in 64K increments from 64K up to 576K. Includes FREE! disk emulation and printer spooler software.

MEX-57064A Maxicard 64K _____ \$218.95
MEX-57256A Maxicard 256K _____ \$488.95
MEX-57576A Maxicard 576K _____ \$48.95

ACCESSORIES FOR YOUR IBM PC

Quadboard I - QUADRAM

The Quadboard I is a six-function memory and I/O for IBM PC and XT. It includes one parallel port, one asynchronous serial port, a clock/calendar, RAMdisk, and printer spooler. Available with 64K or 256K memory.

MEX-41064A 64K Quadboard I _____ \$279.95
MEX-41256A 256K Quadboard I _____ \$399.95

Quadboard II - QUADRAM

Same features as Quadboard I above, but both I/O ports are asynchronous serial.

MEX-40064A 64K Quadboard II _____ \$279.95
MEX-40256A 256K Quadboard II _____ \$399.95

Quadchrome - QUADRAM Corp

The Quadchrome monitor is a 12-inch super-high resolution RGB color video monitor designed specifically for use with the IBM PC and XT. It utilizes a special .31mm dot-pitch tube to deliver 690 horizontal dots by 480 vertical lines resolution for a crisp state of the art image in 16 brilliant colors. The only color monitor PC will ever need!

VDC-241301 Quadchrome List Price 795.00 — \$499.00

Quadram Quad 512+

Maximum memory plus I/O. The Quad 512+ combines memory expansion of 512K a serial port, RAM disk, and printer spooler. A must for maximum memory!

MEX-42064A 64K List 325.00 _____ \$249.95
MEX-42256A 256K List 550.00 _____ \$429.95
MEX-42512A 512K List 895.00 _____ \$799.95

Quadlink - QUADRAM Corp

The missing link between your IBM PC and the world of Apple software! When installed in an empty slot in your PC, the Quadlink allows you to run Apple software in your PC. Actually gives you two computers in one, allowing you to shift easily between PC DOS and Apple DOS, all within the same IBM PC!

CPX-50500A Quadlink _____ \$495.00

DISKETTES SAVE!

FOR APPLE

Single-sided, double-density. FREE! plastic storage box. Warranted for 6 months.

MMD-5121003 Box of 10 _____ \$18.95

FOR IBM PC

320K, double-sided, double-density. Also may be used for KAYPRO, MORROW, OSBORNE, COMPAQ, etc. FREE! plastic storage box included.

MMD-5220104 Box of 10 _____ \$24.95

VERBATIM Datalife

Critical ANSI certification diskettes. Warranted for 5 years, hub rings standard on minidiskettes. All tracks certified on 8 inch diskettes; full surface certified on 5 1/4 inch diskettes.

5 1/4" (packaged w/plastic storage box & hub ring)

MMD-5120101 SS DD soft sector _____ \$35.00
MMD-5220101 DS DD soft sector _____ \$47.00
MMD-5140101SS QD soft sector _____ \$46.50
MMD-5240101 DS QD soft sector _____ \$59.95

8" (Soft box, no hub ring)

MMD-8110101 SS SD soft sector _____ \$39.95
MMD-8120101 SS DD soft sector _____ \$46.00
MMD-8220101 DS DD soft sector _____ \$57.00
Available only in boxes of 10

VERBATIM Verex

High quality, sensibly priced, 1 year warranty, exceeds all ANSI specifications. All tracks certified.

5 1/4"

MMD-5110100 SS, SD, soft sector _____ \$29.95
MMD-5110110 Apple compatible _____ \$27.50

8"

MMD-8110100 SS SD soft sector _____ \$33.50
MMD-8220100 DS DD soft sector _____ \$45.00
Available only in boxes of 10

VERBATIM Optima

Warranted for 17 years. Over 70 million revolutions average life. All Optima diskettes are full-service diskettes, extra heavy-duty jacket material provides superior protection and longer life.

5 1/4" - Soft Sector

MMD-5120102 SS DD _____ \$67.50
MMD-5220102 DS DD _____ \$88.50

8" - Soft Sector

MMD-8120102 SS DD _____ \$70.00
MMD-8220102 DS DD _____ \$86.50

Available only in boxes of 10

Circle 243 on inquiry card.

Satisfying Your Personal And Professional Computer Needs Since 1975

www.americanradiohistory.com



**JADE IS AN
AUTHORIZED DEALER
FOR EVERY MAJOR
PRINTER
MANUFACTURER
CALL FOR BEST PRICE!**



PRINTERS ON SALE!

380Z by D.T.C.
Based on the same quality mechanism as the Comrex printer, the 380Z contains electronic enhancements that allow it to print at speeds up to 32 cps. Other features include a 48K buffer, proportional spacing, and Diablo 1640/1650/630 compatible protocol. Comes with printwheel, ribbon and users manual. Serial, parallel, and IEEE 488 interfaces standard. One year factory warranty.

PRD-11300 380Z printer	\$1195.00
PRA-11000 Tractor option	\$169.95
PRA-11200 Cut sheet feeder	\$699.95
Cable Please Specify	\$49.95

NEW! Star Delta 10
High speed, low price! 160 cps. 8K buffer (expandable to 16K), serial and parallel interfaces, full graphics, friction and tractor feed. Epson FX-80 compatible

PRM-66120	\$449.95
-----------	----------

Star Micronics Gemini 10X & 15
Up to 120 cps, full graphics, friction and tractor feed Epson FX-80 compatible

PRM-66010 Gemini 10X	CALL
PRM-66015 Gemini 15	CALL
PRA-66200 Serial board. G-10, G-15	\$85.00
PRA-66202 Serial board. G-10X	\$99.00

"Laser-Perf" Printer Paper
Continuous form fan fold paper with clean-perf edges on all sides. Finish size 8 1/2 x 11, box of 1000 sheets, 20 lb stock

PRA-91921 9 1/2 x 11, 1000 sheets	\$14.95
-----------------------------------	---------

Regular Fan-Fold Paper

PRA-91911 9 1/2 x 11, 1000 sheets	\$11.95
PRA-90511 14 x 11, green bar 1000	\$14.95

Okidata - Microline 82,83, & 84
120 cps (82, 83), 200 cps (84), industry standard printers, serial and parallel interfaces, true lower case descenders, handles single-sheet as well as fan fold paper

PRM-43082 Oki 82	CALL
PRM-43083 Oki 82	CALL
PRM-43084 Oki 84 parallel	CALL
PRM-43085 Oki 84 serial	CALL
PRA-43081 2K serial board	\$159.95
PRA-43080 Extra ribbons (2)	\$9.95

Okidata - Microline 92 & 93
160 cps, true correspondence quality printing, full graphics, IBM PC compatible (optional), handles single sheet as well as fan-fold paper, professional design, construction, & quality

PRM-43092 Okidata 92 parallel	CALL
PRM-43093 Okidata 93 parallel	CALL
PRA-43181 2K serial board	\$129.95
PRA-43086 IBM PC ROMS for 92	\$59.95
PRA-43087 IBM PC ROMS for 93	\$59.95
PRA-43080 Extra ribbon (2)	\$9.95

Starwriter F10
High speed letter quality printer. 40 cps daisywheel, sleek low-profile design (8-inch high). Extensive built-in word processing functions, up to 15-inch paper width. Uses standard Diablo style printwheels, low noise for office environments, Centronics or serial interface versions available

PRD-22010 F10/parallel	\$1195.00
------------------------	-----------

NEW! TTX - Compact Daisywheel
Low-profile, contemporary design, & requires 20% to 50% less desk space than most other daisywheel printers. Other features include dual Interface (RS232 & centronics parallel), built-in adjustable pinfeed forms guide, & compatibility with Wordstar print control commands. Including underline, bold print, super & sub-script etc

PRD-44010 TTX 1014	\$599.95
--------------------	----------

Silver Reed EXP-550
Economical Daisywheel printer with 200 words per minute (18 cps), full 15-inch platen, Diablo 630 protocol, 10, 12, 15 pitch or proportional printing. Very quiet, very reliable, a bargain in the under \$1000.00 letter quality printer market

PRD-52001 Parallel. List 895.00	\$669.00
PRD-52002 Serial. List 995.00	\$775.00
PRA-52000 Tractor. List 159.95	\$129.00

Comrex CR-II
Best buy in letter quality printers. NEW! from Comrex! full featured letter quality printer, FREE! 5K buffer, Logic seeking bi-directional printing, boldface proportional spacing, double-strike, backspace, underling, true super script and sub script, drop in daisywheel cartridge

PRD-11101 CR-II parallel	\$499.00
PRD-11102 CR-II serial	\$589.95
PRA-11100 Tractor option	\$119.95
PRA-99700 Cut sheet feeder	\$199.95

Printer Pals - FMJ
Desk top printer stand and paper rack. Fits all printers

PRA-99080 10" printer pal	\$29.95
PRA-99100 15" printer pal	\$39.95
PRA-99700 for letter quality	\$49.95

PRINTER CABLES
Standard cables for Epson, Okidata, or any Centronics type printer

WCA-3636A Centronics to Centronics	\$29.95
WCA-2536A IBM to Centronics	\$39.95

Universal Printer Stand
Free standing deluxe printer stand with chrome plated powder catch, Universal mounting for all 15-inch carriage dot matrix and letter quality printers. List Price \$129.95 31 lbs

FRN-9000 Deluxe printer stand	\$69.95
-------------------------------	---------

Video Monitors

Taxan Monitors
18 MHz 800 lines per inch, ideal for 80 column operation

VDM-821210 12" Amber	\$139.00
VDM-821220 12" Green	\$139.00

Taxan RGB Vision
Apple and IBM compatible RGB color. Now you can have the quality of an RGB color monitor for your Apple III, IBM, or Apple II in your choice of medium or super high resolution. Both of these units feature an 18MHz bandwidth linear video amplifier for limitless color variety and best picture quality in text and graphics. The RGB-Vision I, with 280 lines horizontal resolution is suitable for most demanding applications, your choice should be the Super-high resolution RGB-Vision III with 630 line resolution

VDC-821210 RGB-Vision I	\$369.00
VDC-821230 RGB-Vision III	\$649.00
VDA-821200 Apple II RGB card	\$129.00
VDA-821210 IBM PC cable	19.00
VDA-821220 Apple III cable	\$19.00
VDA-821200 Apple II card & cable	\$129.00
VDA-821230 Apple IIe & 80 Column Card	\$179.00

Taxan Color Monitor
Composite color monitor with audio, 13-inch/400 line screen

VDC-821205 Color monitor	\$399.00
--------------------------	----------

12 inch Green Screen - ZENITH
15 MHz, 40 or 80 column

VDM-201201 12" green	\$94.95
----------------------	---------

NEW! SMART TERMINAL - TTX
The new TTX 3000 is an intelligent, economical, full-feature terminal designed to be expanded into a full computer. It has more features and is priced lower than similar units from ADDS, LSI, Hazeltine, and Televideo. In addition to all the built-in features, there is also space inside the unit for a 6 x 12 inch single board computer, and provisions for mounting two half height 5 1/4 inch disk drives (and sufficient power supply current to run the add-ins). The detached keyboard features 95 keys, with numeric keypad and 10 function keys. Screen is designed to tilt and swivel for comfortable viewing. Emulate TV 925

VDT-461201 TTX-3000	\$469.00
---------------------	----------

Place Orders Toll Free!
Circle 243 on inquiry card.

Continental U.S.A. (800) 421-5500
Inside California (800) 262-1710
Los Angeles Area (213) 973-7707

www.americanradiohistory.com

Do Kay

COMPUTER
PRODUCTS,
Inc.

ORDER TOLL FREE

(800)

538-8800

(CALIFORNIA RESIDENTS)

(800)

848-8008



TERMS: For shipping include \$2.00 for UPS Ground or \$3.00 for UPS Blue Air. \$10.00 minimum order. Bay Area and Los Angeles Counties add 6½% Sales Tax, other California residents add 6% Sales Tax. We reserve the right to limit quantities and substitute manufacturer. Prices subject to change without notice.

VISIT OUR RETAIL STORE

2100 De La Cruz Blvd.
Santa Clara, CA 95050
(408) 988-0697

Do Kay

STATIC RAMS

2101	256 x 4 (450ns)	1.90
5101	256 x 4 (450ns) (cmos)	3.90
2102-1	1024 x 1 (450ns)	.88
2102L-4	1024 x 1 (450ns) (LP)	.98
2102L-2	1024 x 1 (250ns) (LP)	1.45
2111	256 x 4 (450ns)	2.45
2112	256 x 4 (450ns)	2.95
2114	1024 x 4 (450ns)	8/9.90
2114-25	1024 x 4 (250ns)	8/9.95
2114L-4	1024 x 4 (450ns) (LP)	8/11.95
2114L-3	1024 x 4 (300ns) (LP)	8/12.45
2114L-2	1024 x 4 (200ns) (LP)	8/12.95
2147	4096 x 1 (55ns)	4.40
TMS4044-4	4096 x 1 (450ns)	3.45
TMS4044-3	4096 x 1 (300ns)	3.95
TMS4044-2	4096 x 1 (200ns)	4.45
MK4118	1024 x 8 (250ns)	9.90
TMM2016-200	2048 x 8 (200ns)	4.10
TMM2016-150	2048 x 8 (150ns)	4.90
TMM2016-100	2048 x 8 (100ns)	6.10
HM6116-4	2048 x 8 (200ns) (cmos)	4.70
HM6116-3	2048 x 8 (150ns) (cmos)	4.90
HM6116-2	2048 x 8 (120ns) (cmos)	8.90
HM6116LP-4	2048 x 8 (200ns) (cmos)(LP)	5.90
HM6116LP-3	2048 x 8 (150ns) (cmos)(LP)	6.90
HM6116LP-2	2048 x 8 (120ns) (cmos)(LP)	9.95
Z-6132	4096 x 8 (300ns) (Qstat)	33.95

LP = Low Power Qstat = Quasi-Static

DYNAMIC RAMS

TMS4027	4096 x 1 (250ns)	1.95
UPD411	4096 x 1 (300ns)	2.95
MMS280	4096 x 1 (300ns)	2.95
MK4108	8192 x 1 (200ns)	1.90
MMS298	8192 x 1 (250ns)	1.80
4116-300	16384 x 1 (300ns)	8/10.75
4116-250	16384 x 1 (250ns)	8/10.95
4116-200	16384 x 1 (200ns)	8/11.95
4116-150	16384 x 1 (150ns)	8/13.95
4116-120	16384 x 1 (120ns)	8/28.95
2118	16384 x 1 (150ns) (5v)	4.90
4164-200	65536 x 1 (200ns) (5v)	5.90
4164-150	65536 x 1 (150ns) (5v)	6.90

5V = single 5 volt supply

EPROMS

1702	256 x 8 (1us)	4.45
2708	1024 x 8 (450ns)	3.90
2758	1024 x 8 (450ns) (5v)	5.90
2716	2048 x 8 (450ns) (5v)	3.90
2716-1	2048 x 8 (350ns) (5v)	5.90
TMS2516	2048 x 8 (450ns) (5v)	5.45
TMS2716	2048 x 8 (450ns) (5v)	7.90
TMS2532	4096 x 8 (450ns) (5v)	5.90
2732	4096 x 8 (450ns) (5v)	4.90
2732-250	4096 x 8 (250ns) (5v)	8.90
2732-200	4096 x 8 (200ns) (5v)	10.95
2764	8192 x 8 (450ns) (5v)	9.90
2764-250	8192 x 8 (250ns) (5v)	13.95
2764-200	8192 x 8 (200ns) (5v)	23.95
TMS2564	8192 x 8 (450ns) (5v)	16.95
MC68764	8192 x 8 (450ns) (5v)(24 pin)	38.95
27128	16384 x 8Call	Call

5v = Single 5 Volt Supply

74LS00

74LS00	.23	74LS173	.88
74LS01	.24	74LS174	.54
74LS02	.24	74LS175	.54
74LS03	.24	74LS181	2.10
74LS04	.23	74LS189	8.90
74LS05	.24	74LS190	.88
74LS08	.27	74LS191	.88
74LS09	.28	74LS192	.88
74LS10	.24	74LS193	.78
74LS11	.34	74LS194	.68
74LS12	.34	74LS195	.68
74LS13	.44	74LS196	.78
74LS14	.58	74LS197	.78
74LS15	.34	74LS221	.88
74LS20	.24	74LS240	.94
74LS21	.28	74LS241	.98
74LS22	.24	74LS242	.98
74LS26	.28	74LS243	.98
74LS27	.28	74LS244	1.25
74LS28	.34	74LS245	1.45
74LS30	.24	74LS247	.74
74LS32	.28	74LS248	.98
74LS33	.54	74LS249	.98
74LS37	.34	74LS251	.58
74LS38	.34	74LS253	.58
74LS40	.24	74LS257	.58
74LS42	.48	74LS258	.58
74LS47	.74	74LS259	2.70
74LS48	.74	74LS260	.58
74LS49	.74	74LS266	.54
74LS51	.24	74LS273	1.45
74LS54	.28	74LS275	3.30
74LS55	.28	74LS279	.48
74LS63	1.20	74LS280	1.95
74LS73	.38	74LS283	.68
74LS74	.34	74LS290	.88
74LS75	.38	74LS293	.88
74LS76	.38	74LS295	.98
74LS78	.48	74LS298	.88
74LS83	.59	74LS299	1.70
74LS85	.68	74LS323	3.45
74LS86	.38	74LS324	1.70
74LS90	.54	74LS352	1.25
74LS91	.88	74LS353	1.25

74LS92	.54	74LS363	1.30
74LS93	.54	74LS364	1.90
74LS95	.74	74LS365	.48
74LS96	.88	74LS366	.48
74LS107	.38	74LS367	.44
74LS109	.38	74LS368	.44
74LS112	.38	74LS373	1.35
74LS113	.38	74LS374	1.35
74LS114	.38	74LS377	1.35
74LS122	.44	74LS378	1.13
74LS123	.78	74LS379	1.30
74LS124	2.85	74LS385	1.85
74LS125	.48	74LS386	.44
74LS126	.48	74LS390	1.15
74LS132	.58	74LS393	1.15
74LS133	.58	74LS395	1.15
74LS136	.38	74LS399	1.45
74LS137	.98	74LS424	2.90
74LS139	.54	74LS447	.36
74LS145	1.15	74LS490	1.80
74LS147	2.45	74LS624	3.95
74LS148	1.30	74LS640	2.15
74LS151	.54	74LS645	2.15
74LS153	.54	74LS668	1.65
74LS154	1.85	74LS689	1.85
74LS155	.68	74LS670	1.45
74LS156	.68	74LS674	9.60
74LS157	.64	74LS682	3.15
74LS158	.58	74LS683	3.15
74LS160	.68	74LS684	3.15
74LS161	.64	74LS685	3.15
74LS162	.68	74LS688	2.35
74LS163	.64	74LS689	3.15
74LS164	.68	74LS783	23.95
74LS165	.94	81LS95	1.45
74LS166	1.90	81LS96	1.45
74LS168	1.70	81LS97	1.45
74LS169	1.70	81LS98	1.45
74LS170	1.45	25LS2521	2.75
		25LS2569	4.20

6500 1MHZ

6502	4.90
6504	6.90
6505	8.90
6507	9.90
6520	4.30
6522	7.90
6532	9.90
6545	21.50
6551	10.85

2 MHZ

6502A	6.90
6522A	9.90
6532A	10.95
6545A	26.95
6551A	10.95

3 MHZ

6502B	13.95
-------	-------

6800

68000	58.95
6800	3.90
6802	7.90
6808	12.90
6809E	18.95
6809	10.95
6810	2.90
6820	4.30
6821	3.20
6828	13.95
6840	11.95
6843	33.95
6844	24.95
6845	13.95
6847	10.95
6850	3.20
6852	15.70
6860	9.90
6862	10.95
6875	6.90
6880	2.20
6883	21.95
68047	23.95
68488	18.95

6800 1MHZ

68B00	9.95
68B02	21.25
68B09E	28.95
68B09	28.95
68B10	6.90
68B21	6.90
68B45	18.95
68B50	5.90

8000

8035	5.90
8039	6.90
INS-8060	16.95
INS-8073	23.95
8080	3.90
8085	5.90
8085A-2	10.95
8086	28.95
8087	CALL
8088	38.95
8089	88.95
8155	6.90
8155-2	7.90
8156	6.90
8185	28.95
8185-2	38.95
8741	38.95
8748	23.95
8755	23.95

8200

8202	23.95
8203	38.95
8205	3.45
8212	1.75
8214	3.80
8216	1.70
8224	2.20
8226	1.75
8228	3.45
8237	18.95
8237-5	20.95
8238	4.45
8243	4.40
8250	9.95
8251	4.45
8253	6.90
8253-5	7.90
8255	4.45
8255-5	5.20
8257	7.90
8257-5	8.90
8259	6.85
8259-5	7.45
8271	38.95
8272	38.95
8275	28.95
8279	8.90
8279-5	9.00
8272	6.45
8283	6.45
8284	5.45
8286	6.45
8287	6.45
8288	24.00
8289	48.95

Z-80

2.5 Mhz

Z80-CPU	3.90
Z80-CTC	4.45
Z80-DART	9.95
Z80-DMA	13.95
Z80-PIO	4.45
Z80-SIO/0	15.95
Z80-SIO/1	15.95
Z80-SIO/2	15.95
Z80-SIO/9	15.95

4.0 Mhz

Z80A-CPU	4.90
Z80A-CTC	4.90
Z80A-DART	10.95
Z80A-DMA	15.95
Z80A-PIO	4.90
Z80A-SIO/0	15.95
Z80A-SIO/1	15.95
Z80A-SIO/2	15.95
Z80A-SIO/9	15.95

6.0 Mhz

Z80B-CPU	12.95
Z80B-CTC	12.95
Z80B-PIO	12.95
Z80B-DART	18.95

ZILOG

Z6132	33.95
Z8671	38.95

DISC CONTROLLERS

1771	15.95
1791	23.95
1793	25.95
1795	48.95
1797	48.95
2791	53.95
2793	53.95
2795	58.95
2797	58.95
6843	33.95
8272	38.95
UPD765	38.95
MB8876	28.95
MB8877	33.95
1691	16.95
2143	17.95

UARTS

AY3-1014	6.90
AY5-1013	3.90
AY3-1015	6.90
PT-1472	9.90
TR1602	3.90
2350	9.90
2651	8.90
TMS6011	5.90
IM6402	7.90
IM6403	8.90
INS8250	9.95

INTERFACE

8T26	1.54
8T28	1.84
8T95	.88
8T96	.88
8T97	.88
8T98	.88
DM8131	2.90
DP8304	2.24
DS8835	1.94
DS8836	.98

VOLTAGE REGULATORS

7805T	.74	7905T	.84
78MO5C	.34	7908T	.84
7808T	.74	7912T	.84
7812T	.74	7915T	.84
7815T	.74	7924T	.84
7824T	.74	7905K	1.44
7805K	1.34	7912K	1.44
7812K	1.34	7915K	1.44
7815K	1.34	7924K	1.44
7824K	1.34	79L05	.78
78L05	.68	79L12	.78
78L12	.68	79L15	.78
78L15	.68	LM323K	4.90
78H05K	9.90	UA78S40	1.90
78H12K	9.90		

C,T = TO-220 K = TO-3 L = TO-92

DIP SWITCHES

4 POSITION	.84
5 POSITION	.89
6 POSITION	.89
7 POSITION	.94
8 POSITION	.94

IC SOCKETS

	1-99	100
8 pin ST	.12	.10
14 pin ST	.14	.11
16 pin ST	.16	.12
18 pin ST	.19	.17
20 pin ST	.28	.26
22 pin ST	.29	.26
24 pin ST	.29	.26
28 pin ST	.39	.31
40 pin ST	.48	.38
64 pin ST	4.20	call

ST = SOLDEXTAIL

8 pin WW	.58	.48
14 pin WW	.68	.51
16 pin WW	.68	.57
18 pin WW	.98	.89
20 pin WW	1.04	.97
22 pin WW	1.34	1.23
24 pin WW	1.44	1.30
28 pin WW	1.64	1.44
40 pin WW	1.94	1.75

WW = WIREWRAP

16 pin ZIF	6.70	call
24 pin ZIF	9.90	call
28 pin ZIF	9.95	call

ZIF = TEXTTOOL (Zero Insertion Force)

CRYSTALS

32.768khz	1.90
1.0 mhz	4.29
1.8432	4.90
2.0	3.90
2.097152	3.90
2.4576	3.90
3.2768	3.90
3.579535	3.90
4.0	3.90
5.0	3.90
5.0688	3.90
5.185	3.90
5.7143	3.90
6.0	3.90
6.144	3.90
6.5536	3.90
8.0	3.90
10.0	3.90
10.738635	3.90
14.31818	3.90
15.0	3.90
16.0	3.90
17.430	3.90
18.0	3.90
18.432	3.90
20.0	3.90
22.1184	3.90
32.0	3.90

RESISTORS

1/4 WATT 5% CARBON FILM ALL STANDARD VALUES FROM 1 OHM TO 10 MEG OHM

50 PCS.	1.25
100 PCS.	2.00
1000 PCS.	15.00

APPLE ACCESSORIES

80 Column Card	129.95
16 K Card	42.50
Fan	38.95
Power Supply	84.95
RF Mod	24.95
Joy Stick (Apple II)	29.95
Paddles Apple	9.95
Z80 Card	129.95
SCRG Switch-A-Slot	19.95
Paddle Adapple	24.95
Extend-A Slot	19.95
Disk Drive	224.95
Controller Card	69.95

5 1/4" DISKETTES

ATHANA OR NASHUA

SSSD	18.95
SSDD	22.95
DSDD	27.95

PERISOFT

ACCESSORIES FOR APPLE II & Iie
ALL WITH 1 YEAR WARRANTY BY

PRINTERLINK

CENTRONICS
PARALLEL INTERFACE

- Simple to use — No configuring required
- Use with any centronics printer — EPSON, OKIDATA, etc.

• Includes Cable & Manual

\$58⁰⁰

MESSENGER

SERIAL INTERFACE

- Connects to any RS-232 serial device
- 8 switch selectable drivers for printers, terminals and modems

• Includes Cable & Manual

\$98⁰⁰

TIMELINK

REAL TIME CLOCK

- Applications in file management, word processing, communications, etc.
- Exclusive Alarm Clock feature
- Battery recharges automatically

\$83⁰⁰

NEW BUFFERLINK

ADD-ON PRINTER BUFFER

- No more waiting for printed output
- Connects easily to any parallel interface
- Expandable from 16K to 64K

\$138⁰⁰ (16K)

The Flip Sort™

The new Flip Sort™ has all the fine qualities of the original Flip Sort™, with some added benefits. Along with a new design, capacity has increased 50%, to hold 75 diskettes and the price is more reasonable than ever. \$19.95 ea.

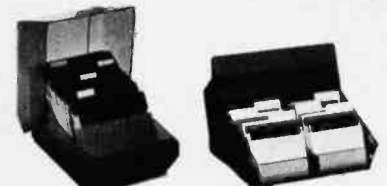

The Flip Sort Plus™

The Flip Sort Plus™ adds new dimensions to storage. Designed with similar elegant lines as the original Flip Sort™, in a transparent smoked acrylic. The Flip Sort Plus™ has a storage capacity of over 100 diskettes and has all the outstanding features you have come to expect from the flip sort family. 24.95 each

Do Kay

2100 De La Cruz Blvd.
Santa Clara, CA 95050

SPECIALS OF THE MONTH

Okidata

Microline 92

- 160 cps
- 10" Carriage

\$489

Star Micronics

Delta 10

- 160 cps
- 10" carriage
- 8K Buffer
- Par. & Ser. Interface

\$449

Microtek

Bam 16

- 16K Card
- For Apple & Franklin
- 2 year warranty

\$49

Microtek

Dumpling GX

- Same as Grappler +
- Full Graphic Interface
- Works w/Apple & Franklin
- Includes Card & Cable
- 2 year warranty

\$89

Orange Micro

Grappler +

- 16K
- Cable Included
- Expand to 64K

\$179

Quentin Research

- Fully Compatible w/Apple
- Faster than Apple Disk Drive
- More Storage

1 for \$219
2 for \$420

5 1/4" Diskettes

100 for ONLY \$250

- Dbl. Side/Dbl. Density
- 5 year Warranty
- Reinforced Hub

Sgl. Side /Dbl. Density
100 for \$150

1/2 Height for IBMPC

- Panasonic
- 320K of Storage
- Mounting Brackets Included

1 for \$205
2 for \$400

Hayes 1200B for IBM

- Smart Com II Included
- Made for IBM
- w/IBM Software

ONLY \$429

Disk Drive Cabinet

- Single Cabinet
- w/Power Supply

\$55

IBMPC

- IBM 256K
- Keyboard
- 2, 320K Disk Drives
- Green Monitor
- Color Card

\$2895

Call for other configurations

Franklin Starter System

- Franklin Ace 1000 w/64K
- Green Monitor
- Disk Drive (Slimline) & Controller

\$1145

Franklin

- 1200 Starter
- w/Green Monitor
- 1 Drive

\$1695

Super 5

- 1/2 Height Drive
- Fully Apple Compatible
- 1 Year Warranty

1 for \$209
2 for \$400

Gorilla

- 12" Green Monitor
- Composite Video
- (20 MHz) Hi-Res

ONLY \$99

CALL 800-847-1718

- Dealer Inquiries Invited
- Quantity Discounts Available

We Offer More Than ^{Just} Low Prices!!!

SCHOOL SPECIALS

P.O.'s from Universities

CALL 800-847-1718



PERSONAL / PORTABLE SYSTEMS

Franklin	
Ace 1000 w/color	Call
Ace 1200 w/Drive	Call
Apple	
IIe	\$ 990
IIe Starter System	1395
IBM	
IBMPC 64K Keyboard, 1 Drive	\$1995
IBMPC XT	4595
Call for all Configurations	
Kaypro	
Kaypro II	\$1450
Kaypro 4	1850
Kaypro 10	2595
Columbia	
1600-1 2 320K Drives	\$2395
Eagle	
Eagle II	\$1895
Corona	
Portable 1 Drive	\$1995
Desk Top Computer	2295

APPLE, FRANKLIN Accessories

Advanced Logic Systems	
Com 3.0 Card	\$ 299
Z Card CPM Card	139
Astar	
RF Modulator	\$ 18
Gibson	
Light pen for Apple II & IIe	\$ 249
Kensington	
System Saver / Fan & Surge	\$ 69
Micro Max	
Vlewmax 80E w/ 64K of Ram Exp. to 128K	\$ 149
Micro Soft Products	
Softcard w/ cpm	\$ 239
16 K Card	65
Premium Pack	469
Micro Tek	
Ram 16 16K card	\$ 49
Call for Other Microtek pricing	
Kraft	
Joystick	\$ 42
Joystick (IBM)	45
Videx	
Videoterm	\$ 209
CCS	
Serial Interface	\$ 119
TG Products	
Joystick	\$ 39
Paddles	28
Selecta Port	38

LOW PRICED Hi Quality DISKETTES

5 1/4" Disks	
Sgl Side / Dbl Density	\$17 a box
Dbl Side / Dbl Density	27 a box
8" Disks	
Sgl Side / Dbl Density	\$28 a box
Dbl Side / Dbl Density	34 a box
All Disks come w/ Reinforced Hub, 5 yr warranty and not bulk packed.	
Advanced Access	
Smoked Plexiglass Diskette Tub Holds 80	\$ 19
8" Version	26

IBM PC ACCESSORIES

Ast Research	
IO + Serial port & Clock Calendar	\$ 119
Combo + 64K Serial, Paralel & c/c	269
Mega + 64K Serial c/c	269
Mega Pak	256
Expands Mega + to 512K	289
Maynard	
FDC Disk Controller	\$ 155
FDC/PP Disk Controller w/par. port	205
FDC/SP Disk Controller w/ser. port	225
Quadram	
Quad Link	\$ 495
Tandon	
TM 100-2 (320K Drive)	\$ 225
1/2 Disk Drive	
Slimline Disk Drive	\$ 205
Expansion Ram	
4164, 200NS	6 ea. 9 for \$ 50
USI	
Multi Display Card	\$ 340

MODEMS

Hayes Micro Computer	
300 Baud Smart Modem	\$ 199
1200 Baud Smart Modem	499
Micro Modem II	259
Micro Modem II w/ Terminal Package	279
Novation	
J-Cat 300 Baud	\$ 119
Apple Cat II	269

5 1/4" & 8" DISK DRIVES

Siemens	
FDD100-8D 8" Sgl/Dbl Den	\$ 169
Mitsubishi	
2894-63 Dbl/Dbl Den	\$ 389
Shugart	
SA801R Sgl/Dbl Den	\$ 355
SA851R Dbl/Dbl Den	469
Tandon	
TM 100-1 160K	\$ 160
TM 100-2 320K	225
TM 101-4 quad Density	339
TM 848-1 Sgl/Dbl Den	359
TM 848-2 Dbl/Dbl Den	435

DISK DRIVES FOR APPLE & FRANKLIN

Super 5	
Sup-5 Controller	\$ 209
	69
Rana Systems	
Elite I	\$ 249
Elite II	399
Elite III	499
•Add \$79 for Controller	
Micro Sci	
A-2	\$ 219
•Add \$70 for Controller	
Quentin Research	
Apple Mate	\$ 219
Controller	60

DISK DRIVE CABINETS

5 1/4" Cabinets	
Sgl Cabinet w/ pwr. supply	\$ 55
Dual Cabinets w/ pwr supply	85
8" Cabinets	
Sgl Cabinets w/ fan & pwr. supply	209
Dual Cabinets w/ fan & pwr. supply	259

VIDEO DISPLAY MONITORS

USI	
PI 1 (9" Amber HiRes)	\$ 130
PI 2 (9" Green HiRes)	120
PI 3 (12" Amber HiRes)	139
PI 4 (12" Green HiRes)	130
BMC	
12 AU (12" Green)	\$ 79
9191 Color Composite	249
EUN (20MHZ)	134
Zenith	
ZvM123 (12" Green) (New)	\$ 105
Amdek	
300A	\$ 149
310A	169
Color 1 Composite	289
Color II RGB	429
Princeton Graphics	
PGS Hx12 w/ IBM Cable	\$ 475
Taxan	
12" Amber	\$ 139

PRINTERS

C. ITOH	
Gorilla-Banana, 50 cps	\$ 194
Prowriter 8510, 120 cps	349
Prowriter II 1550 (15")	649
Prowriter I Serial	499
Prowriter II Serial	695
Starwriter F-10, 40 pu	1129
8600BP, 180 cps	999
Printmaster F-10-55	1405
Epson	
RX-80 (120 cps)	Call
MX-80FT (80 cps)	Call
FX-80 (160 cps)	Call
FX-100 (15" Carriage)	Call
NEC	
PC8023A (100 cps)	\$ 399
PC8025 (15" Carriage)	699
Okidata	
Microline 92P (160 cps)	\$ 489
Microline 92S (160 cps)	599
Microline 93P (160 cps, 15")	799
Microline 93S (160 cps, 15")	899
Microline 82A (Par. & Serial)	379
Microline 83A (15" Carriage)	629
Microline 84P (200 cps)	929
Microline 84S (200 cps)	999
Star Micronics	
Gemini 10X (120 cps)	\$ 294
Gemini 15 (100 cps)	389
Gemini 15X	489
Delta 10	449

PRINTER ACCESSORIES

Orange Micro	
Grappler +	\$ 119
Grappler + 16K Buffer Exp. to 64K	179
Buffer Board, works w/ Grappler +	119
Fourth Dimension	
Parallel Card & Cable Interface for Apple	\$ 49
Microtek	
Dumpling GX Graphic Printer Interface	\$ 89
Dumpling GX 16 interface w/ 16K of Buf	149
Additional Buffering 16K	15
Cables	
IBM to Printer	\$ 29
Kaypro to Printer	29
Osborne to Printer	29

No Surcharge for Credit Cards



Circle 91 on inquiry card.

Computer Components Unlimited

800-847-1718
OUTSIDE CALIFORNIA

NEW RETAIL STORE:
11976 Aviation Blvd.
Inglewood, CA 90304

MAIL ORDER:
P.O. Box 1936
Hawthorne, CA 90250

Technical & Customer Service
(213) 219-0808

All merchandise new. We accept MC, Visa, Wire Transfer, COD Call, Certified Check, P.O.'s from qualified firms, APO accepted. Shipping: Minimum \$4.50 first 5 pounds. Tax: California Res. Only add 6 1/2% Sales tax.

Prices Subject to Change

Mon. - Fri. 8 a.m. to 6 p.m.
Sat. & Sun. 10 a.m. to 5 p.m.

SDSYSTEMS
A SYNTECH COMPANY

S-100 BOARDS & CP/M PLUS™

OUR SD PRICES AND SUPPORT ARE THE BEST!

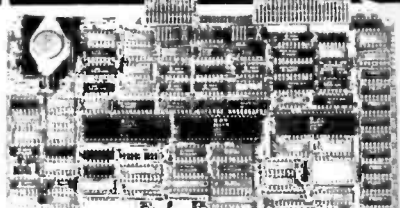

SBC 300

Z-80 Single Board Computer

- Fully complies with IEEE 696 (S100) Bus Standard
- Z-80 CPU: 4 or 6 MHz
- 64 K Bytes of RAM with parity
- 2 to 16 K Bytes of PROM
- 24 bit addressing to 16 M Bytes
- Full SASI Port with 8 bit I/O data bus
- Fully Programmable Communications Options
- Dual Programmable Serial Full-Duplex Channels
- Supports CP/M Plus, MP/M, and TURBODOS
- Permanent Bus Master or Slave
- Two Full Duplex Serial Ports
- Asynchronous, Synchronous, or HDLC
- Software Selectable Baud Rate 50-57,600
- Software Selectable 5, 6, 7 or 8 Bits/Characters; Even, Odd, or No Parity, 1, 1.5, 2 Stop Bits
- CRC Generation/Checking/Sync Modes
- Polled I/O or Interrupt
- 3-16 Bit Counter Timers/8536 CIO Chip
- 1 Year Warranty

Part No.	Description	List Price	Our Price
BV SDS38095	Z80A 4MHz A&T	\$741.00	\$629.00
BV SDS38092	Z80B 6MHz A&T	\$825.00	\$699.00
BV PGC26924DS	2' Internal Serial I/O cable		\$ 14.65
BV PGC50M12S	12" 50 pin internal disk cable		\$ 23.60

VERSAFLOPPY III

Floppy and Hard Disk Controller

- S-100 (IEEE/696) Compatible
- Supports four 5 1/4" or 8" floppies
- Phased lock loop data separator
- Supports three 5 1/4" Winchester drives
- Complete error checking
- 2K byte sector buffer
- Data transfer of up to 5M bytes/sec.

Available September, 1983 — ORDER TODAY!

BV SDS38099	VFW-3 Disk Controller (A&T)	\$ 895.00	\$765.00
BV PDBVF339141*	w/5 1/4" unbanked CP/M® 3.0	\$1083.00	\$895.00
BV PDBVF339142*	w/8" unbanked CP/M® 3.0	\$1083.00	\$895.00
BV PDBVF339143*	w/5 1/4" banked CP/M® 3.0	\$1083.00	\$895.00
BV PDBVF339144*	w/8" banked CP/M® 3.0	\$1083.00	\$895.00

VERSAFLOPPY II/696

Floppy Disk Controller

- S-100 (IEEE/696) compatible
- Concurrent support of 4 drives of 5 1/4" or 8"
- Double density formats
- Separate connectors for 5 1/4" and 8" drive cables
- Single and double sided disk drive capability
- CRC error code checking
- Phased locked loop data separator
- Recommended for operation with the Z80 CPU

BV SDS38098	Versafloppy II/696 (A&T)	\$400.00	\$359.99
BV PDBVF239141*	With 5 1/4" unbanked CP/M®	\$520.00	\$429.00
BV PDBVF239142*	With 8" unbanked CP/M®	\$520.00	\$429.00
BV PDBVF239143*	With 5 1/4" banked CP/M®	\$520.00	\$429.00
BV PDBVF239144*	With 8" banked CP/M®	\$520.00	\$429.00

SOFTWARE-CP/M PLUS™ 3.0

SYSTEM REQUIREMENTS AND OS INFORMATION:

CP/M® 3.0 requires a minimum of 112K bytes of system RAM partitioned into two banks (64K each) for operation. Memory size parameters are communicated to the OS by menu selections in GENCPM. The OS is divided into two modules, the resident portion that resides in the common memory, and the banked portion that occupies the upper area of BNANK0 (just below the common area). The common area must be from 4K to 16K to be compatible with the distribution configuration.

BV SDS39144	CP/M 3.0 8" banked for SDSSBC300	\$315.00
BV SDS39142	CP/M 3.0 8" unbanked for SDSSBC300	\$315.00
BV SDS39143	CP/M 3.0 5 1/4" banked for SDSSBC300	\$315.00
BV SDS39141	CP/M 3.0 5 1/4" unbanked for SDSSBC300	\$315.00

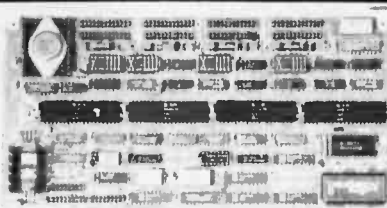

I/O-8

8 Port Serial I/O

- S-100 (IEEE/696) compatible
- Synchronous or asynchronous DTE/DCE
- I/O ports are addressable to any 8 byte boundary in 64K
- Software selectable baud rate
- Full duplex, up to 1 Mbit/sec in synchronous mode
- 5, 6, 7, or 8 data bits/character
- Stop bits - 1, 1.5, 2
- Parity - odd, even, or none
- Error detection - parity, overrun, CRC or framing

Interrupts:

- Receiver ready
- All receive characters

Real Time Clock with Battery Backup

Part No.	Description	List Price	Our Price
BV SDS38093	8 Async serial (A&T)	\$695.00	\$594.00
BV SDS38094	8 Sync serial (A&T)	\$795.00	\$675.00

Cables: Each port has its own 26 pin header. Order one I/O cable for each port use

BV PGC26S24DS	26 pin SKT connector to DB25S 24"	\$ 14.65
BV PGC26S60DP	26 pin SKT connector to DB25P 5'	\$ 15.70
BV PGC26S60DS	26 pin SKT connector to DB25S 5'	\$ 16.55

PROM 100

Eprom Dumper

- S100 (IEEE/696) Compatible
- Programs the Following EPROMs: 2708, Intel 2758, 2716, 2732, and Texas Instruments 2516
- Dip Switch Selection of EPROM type
- 25 VDC Programming Pulse Generated On Board
- Maximum Programming Time: 16,384 Bits in 100 Seconds
- Power Requirement: +8VDC at 300 ma; +16 VDC at 100 ma; -VDC at 60 ma.
- TTL compatible
- Software Listing Provides for Reading of Object File from SDDS, CP/M or PROM and Programming into PROM
- Program Verification
- Verification of Erasure
- Zero Insertion Force Socket
- One Year Warranty

BV SDS38076	PROM-100 w/software(A&T)	\$285.00	\$224.00
-------------	--------------------------	----------	----------

Z80

STARTER SYSTEM

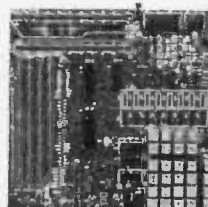

A COMPLETE MICROCOMPUTER ON A BOARD

- Z80 CPU with 158 Instructions
- On-board keyboard and display
- On-board PROM programmer for single voltage PROMs (2716, 2758, TI2516)
- Kansas City standard cassette interface
- Simple key controlled audio cassette load and dump
- Expansion provision for mounting two S-100 connectors (Sockets not included)
- Wire wrap area for custom circuitry
- Single Step through RAM or PROM
- Memory examine and change
- Port examine and change
- Z80 CPU register and change
- 2K Byte ZBUG monitor in ROM
- 1K Bytes of RAM (expandable to 2K Bytes)
- A 4 Channel hardware counter/timer (Z80-CTC)
- Two bi-directional 8-bit I/O ports (Z80-P10)
- Up to 5 programmable breakpoints
- Switch selectable PROM or monitor restart
- Vectored interrupts provided by Z80-CTC and Z80-P10

BV SDS38007	Z80 Starter System (A&T)	\$450.00	\$382.00
-------------	--------------------------	----------	----------

(Shipping Weight 4 lbs.)

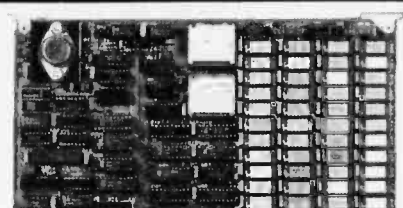

ExpandoRAM IV

256K Dynamic RAM

- S-100 (IEEE/696) compatible
- 256 K Configuration
- DIP Switch Selectable Addressing
- Board may reside anywhere in the 24 Bit address space of the IEEE-696 Bus
- 8 and 16 Bit data Transfers
- Parity Check
- Optional Error Detection/Correction
- Invisible refresh at end of any OP code fetch forced refresh cycle every 10-16 microseconds
- Error Detection and Correction (Hamming Code) 1 bit correction-optional
- 1 Year Warranty

Part No.	Description	List Price	Our Price
BV SDS38088	ExpandoRAM IV 256K (A&T)	\$1145.00	\$ 960.00
BV SDS38089	ExpandoRAM IV 256K w/EDC (A&T)	\$1990.00	\$1780.00

ExpandoRAM III

Random Access Memory Board

- POWER: +7V to +10V @ 400 mA (max)
- 1 year warranty
- Phantom output disable or manual switch selectable output disable
- Typical power dissipation of 5 watts
- 4 MHz operation
- Port addressable board select for multi-user system
- POWER: (2 S memory cycle) +7V to +10 V @ 400 mA (max)
- 1 Year Warranty

BV SDS38097	256K ExpandoRAMIII /696 (A&T)	\$825.00	\$596.99
-------------	-------------------------------	----------	----------

ROM DISK 128

Program Accelerator

- S-100 (IEEE/696) compatible
- 128K Bytes of storage per board
- Uses 16 user supplied 2764 or 2732 type EPROMs
- Up to four boards per system for a total of 512 K
- Meets all IEEE 696/S-100 specifications
- Serial Port provided (using 8251 UART)
- Dip switch selectable addressing
- Looks like a disk drive to the system
- Eliminates media problems
- CP/M Plus support provided
- Ideal for environments where mechanical drives are not practical
- CP/M® and MP/M® install programs
- 1 Year Warranty

BV SDS38081	ROM DISC 128K w/o EPROMs(A&T)	\$350.00	\$296.00
BV SDS1103	ROM DISC Manual		
BV PGC26S24DS	2' Internal Serial I/O cable		

RAM DISK 256

Program Accelerator

- S-100 (IEEE/696) compatible
- 256K bytes of sequentially accessed memory
- On-board transparent refresh (only when the M1 signal is stopped)
- Faster than a floppy disk drive
- Install program included (when configured the RAM DISK-256 looks like a single density 8" disk drive)
- Source code libraries included
- On-board dynamic RAM controller
- Bank addressing allows the use of four boards in the same address to be accessed giving you up to 1 Mbyte of storage
- Asynchronous bus operation and uses the WAIT line only as needed
- 1 Year Warranty

Part No.	Description	List Price	Our Price
BV SDS38082	Ram Disk 256K (A&T)	\$875.00	\$715.00
BV SDS61102	Manual		\$ 10.00

THE INDUSTRY STANDARD



CPU BOARDS

68K - 68000 16 BIT CPU

16 bit 8 or 10 MHz on-board sockets for 2716, 2732, or 2764 EPROMs for up to 8K x 16 of memory

Part No.	Description	List Price	Our Price
BYGBT184A	A&T 8MHz	\$695.00	\$512.95
BYGBT184C	CSC 10MHz	\$850.00	\$785.00

CP/M® 68K NOW AVAILABLE!!

FORTH OPERATING SYSTEM INCLUDED!

Now CompuPro and Digital Research bring you CP/M for the 68000. Also included is the FORTH Operating System which requires a DISK I, 64K of CompuPro memory and an INTERFACER 3 or 4.

BYGBTCPM88K	68000 CP/M® & FORTH O/S	\$350.00
-------------	-------------------------	-----------------

CO-PROCESSOR 8086/8087

16 bit 8 or 10 MHz 8086 CPU with sockets for 8087 and 80136

BYGBT188A	A&T 8MHz 8086 only	\$ 750.00	\$484.95
BYGBT188C	CSC 10MHz 8086 only	\$ 850.00	\$784.89
BYGBT188A87	A&T with 8087 option	\$1050.00	\$939.00
BYGBT188C87	CSC with 8087 option*	\$1150.00	\$1085.00

*8087 Limits clock speed to 5MHz

DUAL PROCESSOR 8085-8088

6 or 8 MHz provides true 16 Bit Power with a standard 8 bit S-100 bus.

BYGBT1812A	A&T 6MHz	\$495.00	\$318.97
BYGBT1812C	CSC 6/8 MHz	\$595.00	\$497.87

CPUZ - Z80B CPU NOW 6MHz!

3/6 MHz Z80B CPU with 24 Bit Addressing
FASTEST Z80 CPU AVAILABLE!

BYGBT180A	3/6 MHz A&T	\$325.00	\$228.95
BYGBT180C	3/6 MHz CSC	\$425.00	\$374.87

DISK CONTROLLERS

DISK 1 DMA FLOPPY CONTROLLER

Fast DMA Soft Sector. Controls Up to Four 8" or 5 1/4" Single or Double Density Drives!

BYPDB171ACPM	A&T w/CPM 2.2* & BIOS	\$670.00	\$489.00
	When purchased w/two 8" disk drives only		\$450.00
BYPOB171CCPM	CSC w/CPM 2.2* & BIOS	\$770.00	\$595.00
BYGBT171A	Disk 1 Controller A&T	\$495.00	\$368.95
BYGBT171C	Disk 1 Controller CSC	\$595.00	\$550.00
BYGBTCPM80	CP/M 2.2* for Z80/8085 w/manual & BIOS 8" S/D disk	\$148.95	\$148.95
BYGBTCPM88	CP/M 2.2* for 8086 w/manuals & BIOS 8" S/D disk	\$258.95	\$258.95

DISK 2/SELECTOR CHANNEL HARD DISK CONTROLLER

Fast DMA 2 board set controls 4 Shugart 4000 series or Fujitsu 2300 type drives. Includes CP/M 2.2*.

BYGBT177A	Assembled & Tested	\$795.00	\$568.95
BYGBT177C	CSC	\$895.00	\$850.00

M-DRIVE/H PROGRAM ACCELERATOR

Interfaces through two I/O ports. And runs at 10MHz IEEE 696 compatible. Requires any CompuPro CPU and a DISK 1. Each board contains 512K of fast, low power (900mA) RAM, with parity checking.

BYGBT197A	M-DRIVE/H w/software. A&T	\$1895.00	\$1249.00
BYGBT197C	M-DRIVE/H w/software. CSC	\$2095.00	\$1495.00

STATIC RAM

RAM 17 - 64K CMOS STATIC RAM

12 MHz. RAM 17, 2 Watt. DMA Compatible 24 Bit Addressing

BYGBT175A64	64K A&T 12MHz	\$499.00	\$480.00
BYGBT175C64	64K CSC 12MHz	\$599.00	\$550.00

RAM 16 - 32K x 16 BIT CMOS STATIC RAM

8 and/or 16 Bit 12MHz. RAM 16, 32K x 16 or 64K x 8 IEEE/696 16 Bit 2 Watt, 24 Bit Addressing, 12MHz

BYGBT180A	64K A&T 12MHz	\$550.00	\$510.00
BYGBT180C	64K CSC 12MHz	\$650.00	\$610.00

RAM 21 - 128K STATIC RAM

816 RAM 21 12MHz, 128K x 8 or 64K x 16 IEEE/696 8 or 16 Bit, 1.2 Amps, 24 Bit Addressing, 12MHz

BYGBT190A	128K A&T	\$1095.00	\$858.95
BYGBT190C	128K CSC	\$1245.00	\$1125.00

I/O BOARDS

SYSTEM SUPPORT 1 MULTIFUNCTION BOARD

Serial port (software prog. baud), 4K RAM included, 15 levels of interrupt, real time clock, optional math processor.

Part No.	Description	List Price	Our Price
BYGBT182A	Assembled & Tested	\$450.00	\$308.95
BYGBT182C	CSC	\$550.00	\$495.00
BYGBT8231	Math Chip		\$195.00
BYGBT8232	Math Chip		\$195.00
BYGBT182AM1	A&T w/8231 Math Chip	\$645.00	\$538.95
BYGBT182CM1	CSC w/8231 Math Chip	\$745.00	\$670.00
BYGBT182AM2	A&T w/8232 Math Chip	\$645.00	\$538.95
BYGBT182CM2	CSC w/8232 Math Chip	\$745.00	\$670.89

S-100 MOTHERBOARDS

Active Termination, 6-12-20 Slot

BYGBT153A	A&T 6 slot (2 lbs.)	\$140.00	\$125.00
BYGBT153C	CSC 6 slot (2 lbs.)	\$190.00	\$155.00
BYGBT154A	A&T 12 slot (3 lbs.)	\$175.00	\$155.00
BYGBT154C	CSC 12 slot (3 lbs.)	\$240.00	\$220.00
BYGBT155A	A&T 20 slot (4 lbs.)	\$265.00	\$235.00
BYGBT155C	CSC 20 slot (4 lbs.)	\$340.00	\$310.00

INTERFACER 1

Two Serial I/O

BYGBT133A	Assembled & Tested	\$295.00	\$198.95
BYGBT133C	CSC	\$370.00	\$329.00

INTERFACER 2

Three parallel, one serial I/O board

BYGBT150A	Assembled & Tested	\$325.00	\$249.00
BYGBT150C	CSC	\$399.00	\$359.00

INTERFACER 3

Eight-channel multi-user serial I/O board

BYGBT1748A	Assembled & Tested	\$699.00	\$518.95
BYGBT1748C	CSC 200 hr. 8 port	\$849.00	\$748.89
BYGBT1745A	Assembled & Tested	\$599.00	\$448.95
BYGBT1745C	CSC 200 hr. 5 port	\$699.00	\$628.89

INTERFACER 4

Three Serial, 1 Parallel, 1 Centronics Parallel

BYGBT187A	Assembled & Tested	\$450.00	\$314.87
BYGBT187C	CSC	\$540.00	\$414.87

MPX CHANNEL BOARDS

I/O Multiplexer, using 8085A-2 CPU on board w/16K RAM

BYGBT186A18	Assembled & Tested	\$649.00	\$584.89
BYGBT186C18	CSC	\$749.00	\$674.89

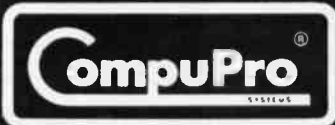

STATIC RAM SALE!!

256K AND 128K IEEE/696 S-100 - ULTRA LOW POWER!

256K RAM 22

12 MHz

SUPER SALE PRICE:

\$1500.00

EACH, WHEN YOU BUY 2 OR MORE

\$1595.00

Each

BYGBT198A

128K RAM 21

12 MHz

SUPER SALE PRICE:

\$650.00

EACH, WHEN YOU BUY TWO OR MORE

\$695.00

Each

BYGBTRAM21 LIST PRICE: \$1295.00

64K 10MHz LOW POWER S-100 IEEE/STATIC RAMS

RAM 17

64K 8 BIT / 24 BIT ADDRESS

BYGBTRAM17 List Price: \$499.00

\$299.00

RAM 16

64K 8 or 32K 16 BIT / 24 BIT ADDRESS

BYGBTRAM16 List Price: \$550.00

\$325.00



PRIORITY ONE ELECTRONICS

916 Deering Ave., Chatsworth, CA 91311



ORDER TOLL FREE (800) 523-5922 - CA, AK, HI CALL (213) 709-5111

Terms: U.S. VISA, MC, BAC, Check, Money Order, U.S. Funds Only. Ca residents add 6 1/2% Sales Tax. MINIMUM PREPAID ORDER \$15.00. Include MINIMUM SHIP-PING & HANDLING of \$3.00 for the first 3 lbs. plus 40¢ for each additional pound. Orders over 50 lbs. sent freight collect. Just in case, include your phone number. Prices subject to change without notice. We will do our best to maintain prices through October, 1983. Many quantities are limited. Sorry, no rain checks, no refunds or exchanges on sale merchandise. Credit Card orders will be charged appropriate freight. Sale prices for prepaid orders only. We are not responsible for typographical errors.

RETAIL STORE PHONE NUMBERS: (Chatsworth:) (213) 709-5464 - (Irvine:) (714) 660-1411

TELETEK

THE SYSTEMASTER Z80 SINGLE BOARD COMPUTER

FEATURES:

- Z80A 4MHz CPU with 64K bytes of on-board RAM
- RAM is partitioned into two banks. One is always active, and the other de-selectable, allowing the use of MP/M
- Provisions for and EPROM (2716, 2732, or 2764)
- Two RS232 serial I/O ports, 45 to 19,200 baud
- Two 8 bit parallel I/O ports
- DMA floppy disk controller
- Single or double density, single or double sided
- Controls up to 4 drives of 5 1/4" or 8" drives
- Simultaneous operation of four 8" and 5 1/4" drives
- Real time clock

SystemMaster™ For Operation With CP/M™

Part No.	Description	List Price	Our Price
BV TLKA1001	Configured with a 250 nS prewrite comp for use with Sugart and Siemens 3" drives	\$895.00	\$850.00
BV TLKA1002	Configured with a 0 nS prewrite comp for use with Oume, Tandem, Mitsubishi and MPI® drives	\$895.00	\$850.00
SystemMaster™ For Operation With TurboDOS™			
BV TLKA1003	Configured with a 250 nS prewrite comp for use with Shugart and Siemens 8" drives	\$895.00	\$850.00
BV TLKA1004	Configured with a 0 nS prewrite comp for use with Oume, Tandem, Mitsubishi, and MPI 8" drives	\$895.00	\$850.00

Shipping weights on above items: 2 lbs. each

SDC-1 Z80A SLAVE PROCESSOR

FEATURES:

- Z80A 4MHz, or Z80B 6MHz CPU
- 128K (fully populated) on board RAM
- Memory can be partitioned onto 4K segments on any 4K boundary
- Provisions for one 2716, 2732, or 2764 EPROM
- Two RS232 serial ports, 45 to 19,200 baud
- Two parallel ports

Part No.	Description	List Price	Our Price
BV TLKA1027	4MHz SBC-1 w/128K RAM	\$ 945.00	\$ 895.00
BV TLKA1028	6MHz SBC-1 w/128K RAM	\$11,500.00	\$1050.00

LONG DISTANCE ADAPTOR BOARDS

BV TLKA1200	PSC (RS232) long distance interface up to 50 ft.	\$125.00	
BV TLKA1202	PSC (RS422) long distance interface up to 4000 ft.	\$125.00	
BV TLKA1220	PPD parallel interface for up to 250 ft.	\$ 65.00	

Z80A MULTI-FUNCTIONED CPU BOARD

FEATURES:

- Z80 4MHz CPU
- Floppy disk controller: Controls single/double sided, single/double density, 5 1/4" and 8" disk drives or both at the same time (4 drives maximum)
- On board 2716 monitor EPROM
- Provisions for two more 2716 EPROMs
- Two RS232 serial ports (45 to 9600 baud)
- Two parallel ports
- Real time clock
- PROM programmer for 2716's (requires an external voltage source)

Part No.	Description	List Price	Our Price
BV TLKA1099	FDC-1 0 nS prewrite comp for use with OUME, MITSUBISHI, TANDON, and MPI	\$695.00	\$860.00
BV TLKA1105	FDC-1 250 nS prewrite comp for use with SHUGART, and SIEMENS	\$695.00	\$860.00

256K DYNAMIC MEMORY BOARD

FEATURES:

- Guaranteed to operate at 4MHz with no wait states
- 256K dynamic RAM uses the popular 4164 IC
- PHANTOM signal disables output of data from the memory board
- On board refresh
- Timing changes are done with jumpers to allow operation with 8080, Z80, 8085, or Alpha Micro CPUs
- Each of 16 banks are made up of 4K byte segments
- Each segment may be individually enabled or disabled

Part No.	Description	List Price	Our Price
BV TLKA1068	Populated to 64K	\$550.00	\$520.00
BV TLKA1069	Populated to 256K	\$995.00	\$945.00

HARD DISK/CARTIDGE TAPE CONTROLLER

FEATURES:

- A Z 80A CPU
- Support of 5 1/4" rigid-disk drives (ST506 or equivalent) with
- Controller communications with the host processor via 2K
- Two 28-pin sockets allowing the use of up to 16K bytes of on-board EPROM and up to 8K bytes of on-board RAM
- Cartridge tape drive
- Expansion is made possible with an external card

Available early 4th Quarter of 1983

BV TLKA1130	Hard Disk/Tape controller 4MHz	\$795.00	\$750.00
BV TLKA1131	Hard Disk/Tape controller 6MHz	\$845.00	\$795.00

4 SERIAL AND 2 PARALLEL BOARD

FEATURES:

- 2 RS232 serial ports with full handshaking, (45-19,200) baud
- Each port is speed independent
- The Z80A CTC may be implemented as a real time clock
- Two parallel ports with the Z80A P/O IC

Part No.	Description	List Price	Our Price
BV TLKA1175	PSIO 4 serial 2 parallel ports	\$325.00	\$295.00

Industrial Computer Designs



S-100 TO "REAL WORLD" INTERFACE PRODUCTS

64 INPUT 8 BIT A/D D/A CONVERTERS

Part Number	Description	Price
BV ICDAD84100	64 input 8 bit S-100 A/D board	\$295.00
BV ICDAD84100	64 output 8 bit S-100 D/A board	\$395.00

REMOTE SENSORS, ALARMS, VALVES, AND CONTROLLERS FOR USE WITH ABOVE A/D D/A CONVERTER BOARDS

BV ICDRTS1	remote temperature sensor (1 lb.)	\$ 29.95
BV ICDRLS1	remote light sensor (1 lb.)	\$ 29.95
BV ICDRMS1	remote moisture sensor (1 lb.)	\$ 59.95
BV ICDRSDA1	remotest smoke detector alarm (2 lbs.)	\$129.00
BV ICDDNVAC1	in-line remote air-conditioner & heating controller (1 lb.)	\$ 94.95

Air Conditioning & Heating Duct Valves

BV ICDADV07	7" diameter valve (4 lbs.)	\$ 74.95
BV ICDADV08	8" diameter valve (4 lbs.)	\$ 75.95
BV ICDADV09	9" diameter valve (5 lbs.)	\$ 76.95
BV ICDADV10	10" diameter valve (5 lbs.)	\$ 79.95
BV ICDADV11	11" diameter valve (6 lbs.)	\$ 81.95
BV ICDADV12	12" diameter valve (6 lbs.)	\$ 83.95
BV ICDADV13	13" diameter valve (6 lbs.)	\$ 84.95
BV ICDADV14	14" diameter valve (6 lbs.)	\$ 85.95

64 PIN CABLE ASSEMBLIES

BV ICD484PCA	64 pin single ended 4' long (2 lbs.)	\$ 69.25
BV ICD1084PCA	64 pin single ended 10' long (3 lbs.)	\$ 89.95
BV ICD2084PCA	64 pin single ended 20' long (6 lbs.)	\$145.00

"HOW TO" APPLICATION NOTES

If you would like to learn more about the ICD Designer Control Series of peripherals, ICD offers a complete collection of "How To" applications notes. See how your computer can control your home or office, or be used as part of an industrial control system.

BV ICDAPN	Application notes (1 lb.)	\$ 15.00
-----------	---------------------------	----------

S-100 CLOCK/CALENDAR BOARDS

BV ICDACAI00	With alarm circuit	\$228.00
BV ICDCT100	With timer down to .01 second	\$345.00
BV ICDCTS	Software for ICDCT100 board on 8" CP/M format	\$ 34.95



Intercontinental Micro Systems

Z80A DMA SDC & Z80B SLAVES

S-100 IEEE/696 COMPATIBLE - 1 YEAR WARRANTY!

CPZ-48000 FEATURES: SLAVE PROCESSOR

- 4MHz Z80A, 64K RAM
- Floppy disk personality card included for 5 1/4" or 8"
- Floppy disk drives
- RS232 personality card included
- Two serial - two parallel I/Os
- Z80 4 or 6MHz CPU (specify at time of order)
- Two Serial - two parallel I/Os
- 64K RAM
- TURBODOS compatible

Part Number	Description	List Price	SALE PRICE
BV ICMCFZ48000B	SBC for 8" floppy	\$995.00	\$895.00
BV ICMCFZ48000S	SBC for 5 1/4" floppy	\$995.00	\$895.00
BV ICMZ58KMB	256 KByte RAM	\$995.00	\$895.00
BV ICMCPS4A	4MHz slave/synch. port	\$475.00	\$439.00
BV ICMCPS4S	4MHz slave/synch. port	\$485.00	\$445.00
BV ICMCPS6A	6MHz slave/synch. port	\$550.00	\$489.00
BV ICMCPS6S	6MHz slave/synch. port	\$560.00	\$499.00

(Shipping weight: 2 lbs. each)

BV ICMRS232	RS232 Personality Card	\$ 25.00
BV ICMCENTD	Centronics Parallel Personality Card	\$ 29.00
BV ICMDFDC	8" Floppy Disk Personality Card	\$ 36.00
BV ICM5FDC	5 1/4" Floppy Disk Personality Card	\$ 33.00
BV ICMCLKAL	Clock Calendar	\$ 48.00

TELETEK SOFTWARE

Software with no prewrite compensation installed.
CP/M™ For SystemMaster™

Part Number	Description	Price
BV TLKB1001	CP/M™ on 8" and 5 1/4" 35 track disks	\$135.00
CP/M™ FOR FDC-1		
BV TLKB1031	CP/M™ on 8" and 5 1/4" 35 track disks	\$135.00
TurboDos™ For All TELETEK Floppy Controllers		
BV TLKB1238	V1.22 single user	\$300.00
BV TLKB1239	V1.22 single user w/Spooling	\$350.00
BV TLKB1240	V1.22 multi user, single user, & Spooling software	\$750.00

Software with a 250 nS prewrite compensation installed.
CP/M™ For The SystemMaster™

BV TLKB1006	CP/M™ on 8" and 5 1/4" 35 track disks	\$135.00
BV TLKB1010	CP/M™ on 8" for TANDON TM848 THINLINE	\$135.00
CP/M™ For The FDC-1		
BV TLKB1038	CP/M™ on 8" and 5 1/4" 35 track disks	\$135.00
BV TLKB1040	CP/M™ on 8" for TANDON TM848 THINLINES	\$135.00



IO5

Part No.	Description	List Price	Our Price
BV SSM105A	2 Serial, 3 Parallel S-100 Interface Assembled & Tested	\$329.00	\$289.95

IO8

BV SSM108A	8 Port Serial I/O S-100 Board Assembled & Tested	\$550.00	\$450.00
------------	--	----------	----------

IO4

BV SSM104A	2 Serial, 2 Parallel I/O S-100 Board Assembled & Tested	\$290.00	\$245.00
------------	---	----------	----------

2708/2716 EPROM PROGRAMMER & EPROM BOARD
Programs 2708 and 2716 EPROMs. Holds 4 2708s (4K) or 4 2716s (8K)

BV SSM108A	Assembled & Tested	\$265.00	\$219.87
------------	--------------------	----------	----------

DUAL

NON VOLATILE CMOS RAMS

8, 16, or 32K 8 or 16 Bit Data. Battery Backup On Board 6MHz, Bank Selectable

BV DULCMEM8	8K A&T	\$495.00	\$450.00
BV DULCMEM16	16K A&T	\$595.00	\$550.00
BV DULCMEM32	32K A&T	\$695.00	\$650.00

256K DYNAMIC MEMORY

256K, 230 ns access time, 2 x 128K organization, 24 bit addressing, parity error detection

BV DULDMEM256K	Assembled & Tested	\$1295.00	\$1195.00
----------------	--------------------	-----------	-----------

32/64K EPROM BOARD

8 or 16 bit data, holds 2716s (32K), or 2732s (64K)

BV DULEPROM32	For 2716s A&T	\$295.00	\$275.00
BV DULEPROM64	For 2732s A&T	\$295.00	\$275.00

A/D CONVERTER

12 Bit Resolution 16 or 32 Channel Input

BV DULAIM12	Assembled & Tested	\$695.00	\$625.00
BV DULAIM12B	Without Instru. Amp	\$645.00	\$598.00

D/A CONVERTER

4 Channel, 12 Bit, 3 Output Modes

BV UDULA0M12	Assembled & Tested	\$695.00	\$618.95
--------------	--------------------	----------	----------

SIERRA DATA SCIENCES

S-100 SDC BOARD

Z80A 4MHz, 2 Serial RS232 Interfaces, 1 parallel interface, 64K RAM, Floppy Disk Controller, provisions for one 2732 EPROM — ALL ON THIS ONE BOARD!

BV USOSSBC	Z80A SBC A&T	\$895.00	\$855.00
BV USOSCPM	CP/M™ operating System on 8" disk		\$150.00
BV USOSTURBDS	Single User TurboDos™ on 8" disk		\$450.00
BV USOSTURBDM	Multi-User TurboDos™ on 8" disk		\$750.00
BV UMCP1231	36 MByte Hard Disk(45lbs)	\$3695.00	\$3250.00

S-100 Z80A SLAVE SDC

Z80A 4MHz, 2 RS232 Serial ports, 4 parallel ports, 64K RAM, EPROM Programmer. Used in multi-user computer system with SDOSSBC.

BV USOSSBCSE	Slave Z80 SBC A&T	\$825.00	\$565.00
--------------	-------------------	----------	----------



California Computer Systems

Z80 CPU 2 or 4MHz

On board RS232 Serial port, On board 2K Monitor, ROM, Power on jump to any location in 64K. LED status indicators for ROM select, halt/state and interrupts.

BV CCS2010A	Z80A 4MHz CPU A&T	\$325.00	\$258.95
-------------	-------------------	----------	----------

CCS271901

BV CCS271901	2 Serial, 2 Parallel, A&T	\$360.00	\$288.95
--------------	---------------------------	----------	----------

CCS27201

BV CCS272001	4 Port Parallel, A&T	\$275.00	\$218.95
--------------	----------------------	----------	----------

CCS271001

BV CCS271001	4 Port Serial, A&T	\$325.00	\$278.95
--------------	--------------------	----------	----------

CCS2830

BV CCS283001	Assembled & Tested	\$550.00	\$428.95
--------------	--------------------	----------	----------

CCS206601

64K Dynamic S-100 ROM. Cromemco CROMIX™ Compatible.

BV CCS206601	Assembled & Tested	\$450.00	\$425.00
--------------	--------------------	----------	----------

CCS2422A

Floppy disk controller w/CP/M 2.2™

BV CCS2422A	Assembled & Tested	\$475.00	\$337.95
-------------	--------------------	----------	----------

ORDER TOLL FREE (800) 523-5922 - CA, AK, HI CALL (213) 709-5111

Circle 374 on inquiry card.

www.americanradiohistory.com

PRIORITY ONE ELECTRONICS

MACROTECH International Corp.

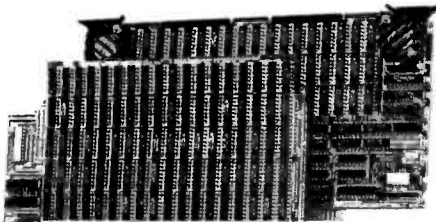

**MACROTECH MAX: 1 SLOT, 1 MEGABYTE!
SEE PAGE 477 FOR MORE DETAILS!**

- Features:**
- S-100/IEEE-696 full compatibility
 - Various configurations — field upgradeable: 256K - 384K - 512K - and 1 Megabyte!
 - High speed — 6MHz in 8 bit environments and 8MHz in 16 bit environments with no wait states
 - Under CP/M 2.2[®], CP/M 3.0[®], CP/M 86[®] or MP/M II[®], all or part of the memory may be divided between system memory and virtual disk
 - M3 Memory mapping option for 8-bit environments (Translated 16-bit logical address to 24-bit physical address). Gives Z-80, 8080, or 8085 16 MEG address space
 - DMA fully supported in accordance with IEEE/696
 - Low power consumption: 4.0 Amps (1 MEG); 3.0 Amps (256K)
 - 6 Layer HOST and 4 layer "piggy-back" card for noise-free operation
 - Fully socketed — Augut HDLITE™ zero profile sockets on all ICs
- ORDERING INFORMATION:** The 256K and 384K versions include the fully socketed Host card. The 512K and larger versions also include the fully socketed "piggy-back" card. To order the M3 Memory Mapping Option, add M3 to the end of the part number and add \$90.00 to the price.

Part Number	Description	Our Price
BVMACMAX256	256K Dynamic RAM (A&T)	\$1225.00
BVMACMAX384	384K Dynamic RAM (A&T)	\$1467.00
BVMACMAX512	512K Dynamic RAM (A&T)	\$1800.00
BVMACMAXM	1MEG Dynamic RAM (A&T)	\$2449.00
BVMACMAXTM	MAX Technical Manual	\$ 15.00
BVMACMAXVSK	MAX Virtual Disk Software supplied on 8" S/D Disk	\$ 25.00

MACROTECH UPGRADE KITS

Each MAX board is upgradeable in 128K increments. Each upgrade includes the RAMs and the proprietary PALS (Programmable Array Logic) required to change the board addressing. Call or write for upgrade kits not listed.

BVMACMK123	Upgrade from 256K to 384K	\$ 265.00
BVMACMK12M	Upgrade from 256K to 1 MEGABYTE	\$1747.00
BVMACMK13M	Upgrade from 384K to 1 MEGABYTE	\$1500.00
BVMACMK15M	Upgrade from 512K to 1 MEGABYTE	\$1005.00

Sierracin/Power Systems



S-100 OPEN FRAME LINEAR SUPPLIES

+ 8V @ 8A + 8V @ 20A
+16V @ 2A +16V @ 4A

BVSP20S100 (9 lbs.) List: \$85.00 BVSP12F5100 (14 lbs.) List: \$140.00
SALE PRICE \$78.00 SALE PRICE \$129.00

SWITCHING POWER SUPPLY FOR DISK DRIVE APPLICATIONS

200 Watt - 5 Output
5V @ 20A 12V @ 4A -5V @ 7A
+12V @ 4A/7.5A Pk 24V @ 3.2A/6A Pk
BVSP57M200 (7 lbs.) List Price: \$275.00

SALE PRICE: \$249.00

IBM-PC™ COMPATIBLE COMPUTER SYSTEM

\$995

S85T0MBC555



MBC-555

Standard Features Include:

- MS DOS
- 16 bit 8088 CPU
- 128K Internal memory
- 1 single sided/double density disk drive (160 Kbytes)
- Color Graphic Capabilities
- Centronic Printer Port
- Diagnostics, Utilities, Speaker & Joystick Port
- Sanyo Basic
- Runs over 80% of IBM-PC™ software
- Word Processing and Spread Sheet Software

BVSY0MBC555 Sanyo IBM-PC™ Compatible Computer (Sh. Wt. 20 lbs.)

\$995.00

ASK ABOUT OUR SPECIAL PACKAGES INCLUDING SANYO MONITORS!

PRINTERS

MORROW

20 cps LETTER QUALITY

The MORROW DESIGNS MP200 type daisywheel printer provides all of the features that you would require in a letter quality printer. Features such as 96 character set, 10/12/15 character pitch and proportional spacing, full 13.2" printing width, and a Centronics parallel interface to list just a few, are what makes the MORROW DESIGNS MP200 your first choice in a low cost letter quality printer.

FEATURES:

- 20 cps (Shannon text) print speed - Bi-directional Printing
- 10/12/15 Character pitch and proportional spacing
- 17" paper width paper capacity - 13.2" printing width
- Prints up to 5 part forms
- Front panel controls of PAUSE, LINE FEED, FORM FEED, TOF SET
- POWER, ALERT, and PRINT ON front panel indicators
- Very quiet operation
- Optional tractor feed

Part Number	Description	List price	Our Price
-------------	-------------	------------	-----------

BVMD5MP200 MP200 w/RS232 serial interface (Shipping weight: 35 lbs.) \$950.00 **\$795.00**

BVMD5MPT50TK MP200 tractor feed **\$125.00**

RIBBON CARTRIDGES

BVSRP5504 Single strike film ribbon \$ 4.95
BVSRP5505 Multistrike ribbon \$ 8.95

PRINT WHEEL

BVSRPCOURIER10 Courier 10 pica \$16.95
BVSRPCOURIER12 Courier 12, elite \$16.95
BVSRPNODEM Proportional type \$16.95
BVSRPSCRIPT Script elite \$16.95

GEMINI 10X & 15

BVGEM10X 120 cps Parallel Int. 80 col. (20 lbs.) \$319.00
BVGEM15 100 cps Parallel Int. 132 col. (26 lbs.) \$459.00
BVGEMSERINT Serial interface card for GEM15 (1 lb.) \$85.00
BVGEMSERINTX Serial interface for GEM10X (1 lb.) \$ 59.00
BVGEMSERINTX4K Serial interface & 4K buffer for GEM10X \$119.00



AXIOM
AXIOM CORPORATION

\$199

OUR LOWEST PRICED PRINTER!
BVXMG100A 30 cps 80 col. dot matrix (11 lbs.) **\$199.00**

OKIDATA

BVOKIDAT82AT TRACTOR INCLUDED (25 lbs.) \$449.00
BVOKIDAT83AT TRACTOR INCLUDED (35 lbs.) \$729.00
BVOKIDAT92AP OKIDATA 92A Parallel (25 lbs.) \$480.00
BVOKIDAT92AS OKIDATA92A Serial (25 lbs.) \$599.00
BVOKIDAT92AT OKIDATA92A Tractor (2 lbs.) \$ 79.95
BVOKIDAT93AP OKIDATA93A Parallel (35 lbs.) \$830.00
BVOKIDAT93AS OKIDATA93A Serial (35 lbs.) \$995.00

MANNESMANN TALLY LETTER QUALITY DOT MATRIX PRINTER

- 160 cps
- 40 cps (Letter quality)
- Serial & Parallel Interface
- Double wide characters
- Tractor and friction feed
- "Bullet-Proof" cast frame with metal cabinet

BVTALMT180L 160 cps 80 col. (21 lbs.) \$569.00
BVTALMT180L 160 cps 132 col. (28 lbs.) \$784.00

QUME LETTER QUALITY

BVQMES945 45 cps Sprint 9 serial (49 lbs.) \$1789.00
BVQMES955 55 cps Sprint 9 serial (49 lbs.) \$2195.00
BVQMES1140 40 cps Sprint 11 (45 lbs.) \$1369.00
BVQMES11RS232 RS232 Module for Sprint 11 (3 lbs.) \$ 99.00
BVQMES11CENT Centronics parallel for Sprint 11 (3 lbs.) \$ 99.00
BVQMES11EE488 IEEE488 Module for Sprint 11 (3 lbs.) \$ 99.00
BVQMES11IBM IBM module for Sprint 11 (3 lbs.) \$ 99.00
BVQMEBDT Bi-Directional Tractor (9 lbs.) \$ 349.00
BVQMEWB Wire basket (2 lbs.) \$ 85.00
BVQMECSF Cut Sheet Feeder (20 lbs.) \$ 649.00



PRIORITY ONE

ELECTRONICS



ORDER TOLL FREE (800) 523-5922 - CA, AK, HI CALL (213) 709-5111

Terms: U.S. VISA, MC, BAC, Check, Money Order, U.S. Funds Only. CA residents add 6.25% Sales Tax. MINIMUM PREPAID ORDER \$15.00. Include MINIMUM SHIPPING & HANDLING of \$3.00 for the first 3 lbs. plus 40¢ for each additional pound. Orders over 50 lbs. sent freight collect. Just in case. Include your phone number. Prices subject to change without notice. We will do our best to maintain prices through October, 1983. Many quantities are limited. Sorry, no rainchecks, no refunds or exchanges on sale merchandise. Credit Card orders will be charged appropriate freight. Sale prices for prepaid orders only. We are not responsible for typographical errors.

RETAIL STORE PHONE NUMBERS: (Chatsworth:) (213) 709-5464 - (Irvine:) (714) 660-1411

Circle 374 on inquiry card.
www.americanradiohistory.com

PRIORITY ONE ELECTRONICS

SIEMENS FDD100-8 8" FLOPPY DISK DRIVE

SINGLE SIDED, DOUBLE DENSITY
SHUGART 801R COMPATIBLE

90 DAY
WARRANTY!!



\$175.00 each
\$169.00 ea. 2 - 9
10+ CALL

OEM INQUIRIES INVITED

BVSIFFD01008 (Include \$7.00 per drive for shipping)

BUY DRIVE & CABINET TOGETHER AND SAVE!!

DUAL 8" SIEMENS FDD1008
DUAL 8" CABINET POWER SUPPLY
AND INTERNAL POWER CABLES

(Include \$30.00 for shipping)



- Positive Pressure Filter Cooling
- Power Supply 4A @ +5V, 3A @ +24V 1A @ -5V
- Each output is individually fused
- Hinged to for easy access
- Heavy non-flex .090 aluminum base
- Modular power connectors

IF BOUGHT SEPARATELY: \$890.00
SPECIAL SALE PRICE:

\$625.00

BVPDBIISIE (Include \$30.00 for shipping)

BVHIFD002 CABINET ONLY (Sh. Wt. 38 lbs.) **\$295.00**

OUR FINEST DUAL 8" DISK DRIVE CABINET!



International
Instrumentation
Incorporated



- Positive pressure forced air cooling for reliable disk drive operation
- AC input EMI filtered to six amps to help prevent disk crashes due to power spikes and line noise
- Integral power supply with 5V @ 6A, 5V @ 1A/24V @ 6A
- Each DC supply and AC separately fused

Part No. List Price Our Price

BVH1UD004 (Sh. Wt. 40 lbs.) \$495.00 **\$348.00**

With augmented power supply to handle Tandem Slimline, or Winchester disk drives. Includes the disk environment monitor.

BVH1UD004AUB (Sh. Wt. 40 lbs.) \$733.00 **\$625.00**

BVH1UD004EM (Sh. Wt. 40 lbs.) \$584.95 **\$395.00**

DUAL 5 1/4" HARD DISK ENCLOSURE

The H1HD5002 enclosure provides all of the necessary power for two TANDON TMS00 series or equivalent hard disk drives, and Xebec Controller. Forced air cooling is provided by a 33 cfm fan, and is filtered to keep your equipment running at its best!



Part Number	Description	List Price	Our Price
BVH1HD5002	Dual hard disk enclosure (Shipping Weight: 20 lbs)	\$425.00	\$375.00

DISK DRIVES TANDON 5 1/4" HARD DISK

BVTNDTM501	1 platter 6 Mbyte (Sh. Wt. 9 lbs.)	\$749.00
BVTNDTM502	2 platter 12 Mbyte (Sh. Wt. 9 lbs.)	\$895.00
BVTNDTM503	3 platter 19 Mbyte (Sh. Wt. 9 lbs.)	\$1049.00

DUAL HARD DISK ENCLOSURE

BVH1HD5002	For above drives	\$395.00
------------	------------------	-----------------

TANDON 5 1/4"

BVTNDTM1001	1 Sided 48 TPI	\$225.00	2 FOR \$195.00 each
BVTNDTM1002	2 Sided 48 TPI	\$260.00	2 FOR \$235.00 each
BVTNDTM1003	1 Sided 96 TPI	\$275.00	2 FOR \$250.00 each
BVTNDTM1004	2 Sided 96 TPI	\$390.00	2 FOR \$365.00 each

(Shipping Weights on above items: 5 lbs. each)

MPI 5 1/4" FULL HEIGHT

BVMP151*	1 Sided 48 TPI	\$200.00
BVMP152*	2 Sided 48 TPI	\$270.00
BVMP191*	1 Sided 96 TPI	\$275.00
BVMP192*	2 Sided 96 TPI	\$400.00

*Replace with an "M" for the MPI style bezel, or with an "S" for Shugart style bezel (Shipping Weight: 5 lbs.)

MPI 5 1/4" HALF HEIGHT

BVMP1501	1 Sided 48 TPI (Sh. Wt. 4 lbs.)	\$260.00
BVMP1502	2 Sided 48 TPI (Sh. Wt. 4 lbs.)	\$300.00
BVMP1901	1 Sided 96 TPI (Sh. Wt. 4 lbs.)	\$300.00
BVMP1902	2 Sided 96 TPI (Sh. Wt. 4 lbs.)	\$355.00

SHUGART 8" FULL HEIGHT

BVSHUB01R	1 sided (18 lbs.)	\$369.00
-----------	-------------------	-----------------

QUME 8" FULL HEIGHT

BVQMEDT8	2 sided (18 lbs.)	\$480.00
----------	-------------------	-----------------

2 FOR **\$460.00** each

MITSUBISHI 8" FULL HEIGHT

BVMITM289483B	2 sided (18 lbs.)	\$380.00
---------------	-------------------	-----------------

MPI 8" FULL HEIGHT

BVMP141S	1 sided (11 lbs.)	\$380.00
BVMP142S	2 sided (11 lbs.)	\$460.00

MPI 8" DUAL HALF HEIGHT

(SAME SIZE AS ONE FULL HEIGHT)

BVMP141D	1 sided (22 lbs.)	\$760.00
BVMP142D	2 sided (22 lbs.)	\$870.00

TANDON 8" HALF HEIGHT

BVTNDTM8481	1 sided (9 lbs.)	\$395.00
-------------	------------------	-----------------

2 FOR **\$375.00** each

BVTNDTM8482	2 sided (9 lbs.)	\$495.00
-------------	------------------	-----------------

2 FOR **\$475.00** each

MPI 8" HALF HEIGHT

BVMP141M	1 sided (11 lbs.)	\$380.00
BVMP142M	2 sided (11 lbs.)	\$460.00

5 1/4" DRIVE CABINETS

BVJMR1C5	Single 5 1/4" Cabinet (5 lbs.)	\$69.00
BVJMR2C5	Dual 5 1/4" Cabinet (9 lbs.)	\$89.00
BVJMR2C5C	JMR2C5 w/internal data cable (9 lbs.)	\$99.00

DUAL 8" HALF HEIGHT FLOPPY CABINET

• 24V @ 4A, 5V @ 3A	• Fan cooled	• Socketed power connections	• All supplies regulated
• -5V @ 800ma			

BVH1TLD02	Dual Thin Line Cabinet (12 lbs.)	\$225.00	\$185.00
-----------	----------------------------------	----------	-----------------

BUY THE CABINET & DRIVES AND SAVE! With 2 Tandem Thinlines

BV/PDBIITND1	Cabinet w/2 TNDTM8481 - 1 sided (30 lbs.)	\$ 885.00
BV/PDBIITND2	Cabinet w/2 TNDTM8482 - 2 sided (30 lbs.)	\$1115.00

With 2 MPI Slimlines

BV/PDBIIMP1	Cabinet w/2 MP141M - 1 sided (30 lbs.)	\$ 920.00
BV/PDBIIMP2	Cabinet w/2 MP142M - 2 sided (30 lbs.)	\$1080.00

Options

BVH1OTLMPK1T	MPI drive adaptor mounting kit (2 lbs.)	\$24.95
BVH1OCCSHU	Shugart / AC/DC power connector kit (2 lbs.) (For full size Single SA801 or compatible drives)	\$14.95

TERMINALS VISUAL 50



(Sh. wt.: 41 lbs.)

Part Number	Description	List Price	SALE PRICE
BVYSL50BW	Black & White 12"	\$695.00	\$625.00
BVYSL50GN	Green Screen 12"	\$770.00	\$655.00

FEATURE COMPARISON CHART

Feature:	VISUAL 50	Hazeltine Exprint	ADDS Viewpoint	Lear Siegler ADM-5	TeleVideo 910
Tilt & Swivel	YES	NO	NO	NO	NO
Detached Keyboard	YES	NO	YES	NO	NO
N-Key Rollover	YES	NO	YES	NO	NO
Audible Key Click	YES	YES	NO	NO	NO
Menu Set-Up Mode	YES	NO	NO	NO	NO
Status Line	YES	NO	NO	NO	NO
Full 5 Attribute Selection	YES	NO	NO	NO	YES
Smooth Scroll	YES	NO	NO	NO	NO
Line Drawing					
Character Set	YES	NO	NO	NO	NO
Independent RCW/ TX Rates	YES	NO	NO	NO	NO
Answerback User Programmable	YES	NO	NO	OPT	NO

VISUAL 330

The VSL330 terminals will emulate the DEC VT52, Data General D200, Lear Siegler ADM-3A, and Hazeltine 1500. Other features include: 12 user programmable function keys, line drawing character set, jump or 2 speed scroll, split screen, full editing, and programmable non-volatile columnar tabbing or field tabbing forward and backward just to name a few.

The VISUAL 300 has all of the same functions as the 330, but does not have multi-emulation. The VISUAL 300 is ANSI X3.64 compatible.

BVYSL300GN	ANSI X3.64, 12" Green	\$1095.00	\$895.00
BVYSL300GN	Green 12" CRT (Sh. Wt. 41 lbs.)	\$1200.00	\$895.00
BVYSL3014GN	Green 14" CRT (Sh. Wt. 41 lbs.)	\$1250.00	\$949.00

TELEVIDEO

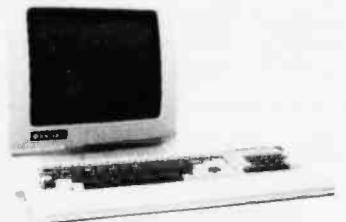

BV/PDBTLV9252P	w/2nd page memory kit FREE (A \$95.00 Value)	\$720.00
BV/PDBTLV9504P	w/2nd, 3rd, & 4th page memory kit FREE (A \$285.00 Value) (above items: 37 lbs. each)	\$920.00

BVTLV10	80 col. terminal (37 lbs.)	\$558.95
BVTLV70	14" 80/132 col. terminal (40 lbs.)	\$1019.00

LIBERTY ELECTRONICS

BVLIF50	Freedom 50 (Sh. Wt. 30 lbs.)	\$599.00	\$474.00
---------	------------------------------	----------	-----------------

ADDS

BVADDYWR	Viewpoint 3A+ (30 lbs.)	\$695.00	\$575.00
----------	-------------------------	----------	-----------------

QUME

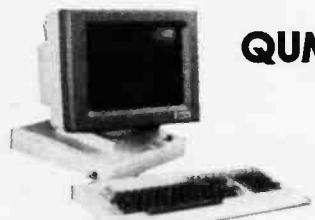

BVQME10Z	80 Column Green (Sh. Wt. 30 lbs.)	\$550.00
BVQME10ZAM	80 Column Amber (Sh. Wt. 30 lbs.)	\$565.00
BVQME103	80/132 Column Green (Sh. Wt. 30 lbs.)	\$765.00
BVQME108	22 function key, 80 col. (Sh. Wt. 30 lbs.)	\$749.00
BVQME108AM	22 function key, 80 col. Amber (30 lbs.)	\$765.00

ORDER TOLL FREE (800) 523-5922 - CA, AK, HI CALL (213) 709-5111 Circle 374 on inquiry card

www.americanradiohistory.com

HP HEWLETT PACKARD CALCULATORS AND HANDHELD COMPUTERS



HP-75C Computer & Software

BV HP-75C Portable Computer (9 lbs.)	\$995.00	\$749.00
BV HP00075-15014 VisiCalc®		\$195.00
BV HP00075-15019 Text Formatter		\$95.00
BV HP00075-15015 Math Pac		\$145.00
BV HP00075-15012 Surveying Pac		\$295.00
BV HP00075-15035 DataCommunications Pac		\$145.00

HP-41C/CV HANDHELD COMPUTER SYSTEM

BV HP-41C Handheld computer	\$195.00	\$159.00
BV HP-41CV Handheld computer w/5x the memory	\$275.00	\$219.00
BV HP02104A Card reader	\$195.00	\$159.00
BV HP02153A Optical Wand	\$125.00	\$ 99.00
BV HP02181A Cassette drive	\$450.00	\$349.00
BV HP02182A Thermal Printer	\$450.00	\$349.00
BV HP02183A Video Interface	\$225.00	\$179.00

(Shipping Weights on above items: 5 lbs. each)

ENHANCEMENT MODULES:

BV HP02180A HP-IL module	\$125.00	\$95.00
BV HP02170A Quad RAM module	\$ 75.00	\$59.00
BV HP02180A Extended functions/memory module	\$ 75.00	\$59.00
BV HP02181A Ext. memory module	\$ 75.00	\$59.00
BV HP02182A Time module	\$ 75.00	\$59.00

(Shipping Weights on above items: 1 lb. each)

We now carry the complete line of series 40 Application Pacs and Solution Books

HP-IL PERIPHERALS For HP-41CV & HP-75C

Part No.	Description	List Price	Our Price
BV HP02180A	HP-IL Interface included in HP-75C	\$125.00	\$ 99.00
BV HP02181A	Digital Cassette Drive	\$450.00	\$349.00
BV HP02176A	Digital Cassettes (10 pack)	\$ 75.00	\$ 95.00
BV HP02182A	Thermal Printer/Plotter	\$450.00	\$349.00
BV HP02125A	Thermal Printer Paper (6 rolls)	\$ 75.00	\$ 10.00
BV HP02163A	Video Interface	\$225.00	\$179.00
BV HP02184A	RS-232 Serial Interface	\$295.00	\$249.00
BV HP02185A	GP10 Interface	\$295.00	\$249.00

SERIES 10 PROGRAMMABLE CALCULATORS

BV HP-10C Scientific	\$ 70.00	\$59.00
BV HP-11C Adv. scientific	\$ 90.00	\$79.00
BV HP-12C Adv. financial	\$120.00	\$99.00
BV HP-15C Adv. sci. w/matrix	\$120.00	\$99.00
BV HP-18C Digital & Computer science	\$120.00	\$99.00

(Shipping Weights on above calculators: 3 lbs. each)

AC SURGE PROTECTORS FOR YOUR COMPUTER



THE LEMON™ SOURS SURGES

Part No.	Description	List Price	Our Price
BV EP0LEMON	6 outlet wall mount w/power switch	\$59.95	\$44.95
BV EP0LIME	6 outlet 4 1/2" cord w/power switch	89.50	\$69.95

(Shipping Weight 4 lbs. each)

EMI-RFI FILTERED AC SURGE PROTECTOR

BV EP0ORANGE	6 outlet 4 1/2" cord w/power switch	\$139.95	\$104.95
BV EP0PEACH	6 outlet wall mount	\$97.50	\$74.95

(Shipping Weight 4 lbs. each)

1200 BAUD MODEM SALE!

U.S. ROBOTICS



PASSWORD 1200 BAUD Auto Originate/ Auto Answer

\$379

Part Number	Description	List Price	Our Price
BV P0BPASSTELB	Password Modem w/Communication Software 8" CP/M®	\$528.00	\$379.00
BV P0BPASSTELS	Password Modem w/Communication Software 5 1/4" Apple	\$528.00	\$379.00
BV P0BDIALTELBA	Auto Dial 212A Modem w/Communication software 8" CP/M®	\$678.00	\$495.00
BV P0BDIALTELS	Auto Dial 212A Modem w/Communication software 5 1/4" Apple	\$678.00	\$495.00

RIXON

1200 BAUD

AUTO DIAL

DIRECT CONNECT MODEMS WITH 10 NUMBER MEMORY

Part Number	Description	List Price	Our Price
BV RIXR212A	1200 Baud Stand Alone unit	\$495.00	\$475.00
BV RIXPC212A	1200 IBM PC™ modem (2 lbs.)	\$495.00	\$475.00
BV RIXPCCOM1	IBM PC™ Modem Software (1 lb.)		\$ 89.00
BV P0BRIX18M	IBM Modem & Software Together (3 lbs.)		\$539.00

D.C. HAYES

BV DCH0400P	1200 Baud Smartmodem	\$695.00	\$514.95
BV DCH0200P	300 Baud Smartmodem	\$279.00	\$229.00
BV DCH0300P	Chronograph	\$249.00	\$199.00
BV DCH0100P	MicroModem 100	\$399.00	\$349.00
BV DCH0000P	MicroModem II	\$379.00	\$299.00

MURA 300 BAUD DIRECT CONNECT

- RS232 C Interface
- Full Duplex
- Bell 103 compatible

\$79.00

Part Number	Description	List Price	Our Price
BV MURM100	0-300 baud modem (2 lbs.)	\$99.55	\$79.00
BV CNDRS2328F	RS232 Cable		\$19.95

INTRODUCING THE LOW COST FLUKE 70 SERIES DMM!

- Analog Bar Graph
- 3200 Count LCD Display
- Fast, Autoranging
- Simple, Single Knob Operation
- Resistance to 32M
- 2000 Hour Battery Life
- Diode Test
- VDE, UL Listed



3 Models/3 Basic Accuracies

BV FLU73	0.7% Accuracy	\$85.00
BV FLU75	0.5% Accuracy	\$99.00
BV FLU77	0.3% Accuracy	\$129.00

(Shipping weights: 5 lbs. each)

BV FLUC70	Vinyl Case	\$ 9.00
BV FLUC71	Holster	\$ 9.00

(Included with FLU77)

12" RGB COLOR VIDEO MONITORS



Part No.	Description	List Price	Our Price
BV TAXR6B1	Medium Resolution/310 lines	\$399.00	\$379.00
BV TAXR6B3	Super High Res/630 lines	\$699.00	\$659.00

Shipping Weight 30lbs.

INTERFACE BOARDS AND CABLES

BV TAXAPPLE2RGB	RGB interface for Apple II	\$145.00	\$139.00
BV TAXA10-80	RGB 80 col int. for Apple IIe	\$199.00	\$185.00
BV TAX18MRGB	RGB cable for IBM PC		\$19.00
BV TAXR6BAPL	RGB cable for Apple IIe and III		\$19.00

Shipping weight: 1 lb on each

5 1/4" FLOPPY DISKETTES

ULTRA MAGNETICS

DOUBLE DENSITY! LIFETIME WARRANTY!

FEATURES:

- Includes reinforcement ring
- 100% Surface tested
- Write protect with tabs
- Lifetime warranty!

SINGLE SIDED

40 TRACKS —	1 BOX	
DOUBLE DENSITY	OF 10:	\$ 25.00
	2 BOXES:	\$ 40.00
	10 BOXES:	\$180.00

BV ULTS1401	Soft Sector	
BV ULTS1410	10 Sector	
BV ULTS1416	16 Sector	
BV ULTS2401	Soft sector, 40 track, 2 sided	
BV ULTS2410	10 sector, 40 track, 2 sided	
BV ULTS2416	16 Sector, 40 track, 2 sided	

1 BOX OF 10	2 BOXES	10 BOXES
\$35.00	\$60.00	\$280.00

(Shipping weights: 1 lb. per box)



PRIORITY ONE ELECTRONICS



916 Deering Ave., Chatsworth CA 91311

ORDER TOLL FREE (800) 423-5922 - CA, AK, HI CALL (213) 709-5111

Terms: U.S. VISA, MC, BAC, Check, Money Order, U.S. Funds Only. CA residents add 6 1/2% Sales Tax. MINIMUM PREPAID ORDER \$15.00. Include MINIMUM SHIPPING & HANDLING of \$3.00 for the first 3 lbs. plus 40¢ for each additional pound. Orders over 50 lbs. sent freight collect. Just in case, please include phone number. Prices subject to change without notice. We will do our best to maintain prices through October, 1983. Many quantities are limited. Sorry, no rain checks, no refunds or exchanges on sale merchandise. Credit Card orders will be charged appropriate freight. Sale prices for prepaid orders only. We are not responsible for typographical errors.

RETAIL STORE PHONE NUMBERS: (Chatsworth:) (213) 709-5464 - (Irvine:) (714) 660-1411

FAST PRECISION A/D FOR APPLE II®

- 40,000 SAMPLES / SECOND DATA ACQUISITION RATE
- 12-BIT RESOLUTION
- 0.1% ACCURACY
- 8 ANALOG INPUT CHANNELS
- REMARKABLE PRICE \$375

ALSO: LOW-COST PRECISION A/D
12 SAMPLES / SECOND \$195

ACCESSORIES

- 2-CHANNEL THERMOCOUPLE THERMOMETER
1° CENTIGRADE ACCURACY \$135
- 6-CHANNEL THERMOMETER \$155
- 16-CHANNEL MULTIPLEXER \$160
- 1-4 CHANNEL OUTPUT CONTROLLER CALL

LAWSON LABS, INC.

5700 RAIBE ROAD
COLUMBIA FALLS, MONTANA 59912
406-387-5355

Circle 555 on inquiry card.

Future Shock!

age **65**
years worked **40**
retirement benefits **0**

The U.S. Department of Labor has a free booklet that will help you answer these questions and a lot more. Send for it today.

Write: Pensions, Consumer Information Center, Pueblo, Colorado 81009

U.S. Department of Labor

BIG SALE

CALL GOODWILL ELECTRONICS CO.

APPLE HARDWARE

Stock Number	Description	Price
AW 101	48K Compact computer (keyboard & Harocase)	\$475
AW 102	Disk drive w/out controller	249
AW 103	Genius 10 Printer	355
AW 104	12" Green monitor	105
AW 201	80 Column card	139
AW 202	2-80 card	129
AW 203	Diakit controller	85
AW 204	Tel modem (RS 232)	75
AW 205	16K RAM card (Language)	49
AW 206	Parallel Card	45
AW 207	APPLE keyboard	79
AW 208	Joy stick deluxe	25
AW 209	Sup-R-Mod	25
AW 210	Power Supply for AW 101	75

We accept Visa, Master Charge, check and C.O.D., CA residents add 6 1/4% Tax.
Shipping \$3.00 for first 3 lbs. 40¢ for each additional

GOODWILL ELECTRONICS CO.
18901 CRENSHAW BLVD
TORRANCE, CA 90504
(213) 532-9624

Circle 557 on inquiry card.

SOURCE SOFTWARE

Professional-quality, CP/M compatible Z80 assembler accepts standard Zilog mnemonics as well as 19 pseudo-ops, prints a sorted symbol table, and can read from multiple input files. Modular structure allows easy revision as a cross-assembler.

Complete source listing with detailed tutorial on theory of assemblers is contained in a 200-page manual. Professional techniques fully explained include Radix 40, binary search, expression processing by recursive descent, etc.

Source code also available on a standard format 8" SSSD disk.

Manual with listing \$25
Manual and 8" disk \$50

(foreign orders add \$3 surface, \$10 airmail)

King Software
PO Box 208
Red Bank, N.J. 07701
(201) 530-7245

NJ residents please add 6% sales tax

Circle 262 on inquiry card.

8" DISKETTES ALSO AVAILABLE

TOP QUALITY 5 1/4 DISKETTES

SPECIFY SOFT, 10 or 16 SECTORS

	\$/10	\$/50	\$/100
• wabash			
SSDD (M13A411X)	23.00	112.00	218.00
DSSD (M14A411X)	30.00	146.00	286.00
• control data			
SSDD (CDC1242-00)	22.00	106.00	210.00
DSSD (CDC1244-00)	30.50	147.00	290.00
• 3M scotch			
SSDD (3M 744D-0)	22.00	109.00	213.00
DSSD (3M 745-0)	31.00	150.00	295.00
• verbatim			
SSDD (MD525-01-18158)	25.20	124.00	245.00
DSSD (MD550-01-18188)	36.50	180.00	355.00
• maxell			
SSDD (MAX-MD-1M)	28.95	140.00	270.00
DSSD (MAX-MDZ-DM)	39.00	192.00	380.00
• dysan			
SSDD (DYS 104-1D)	36.00	177.00	350.00
DSSD (DYS 104-2D)	41.00	202.00	400.00

CALL TOLL FREE 800-824-7888
(VISA, M.C., COD. ORDERS ONLY) OPERATOR 906
7 DAYS A WEEK

Creativity Unlimited

- CHECKS M.O., VISA, M.C. — ADD \$2.00 SHIP
- CA. RESIDENTS ADD 6% SALES TAX
- SURCHARGE ON ORDERS SHIPPED OUTSIDE USA

P.O. BOX 3304
SARATOGA, CA 95070
(408) 252-4210

FREE CATALOG

Dealer Inquiries Invited

Circle 556 on inquiry card.

1ST ANNIVERSARY CHRISTMAS SPECIAL

★ DRAWING FOR A FREE ★



GARDEN OF EDEN COMPUTERS

13147 Cedar Street
Westminster, CA 92683
MAIL ORDERS ONLY
714-894-9528
24 Hours - 7 Days
Hayes Smartmodem
1200 BD RS 232 \$479.00



FOR DETAILS & OUR FREE PRICE LIST
CALL, WRITE OR USE R/S#

Circle 558 on inquiry card.

HOOKING IN THE UNDERGROUND BULLETIN BOARD WORKBOOK

FIRST TIME BETWEEN TWO COVERS '83-'84 EDITION (Periodic Updates)

No matter what type of computer you own, this book will get you on-line TODAY! Complete information on computer bulletin board systems including:

- What they are (and what's happening).
- Kinds of information available.
- Public domain systems.
- Free software (and how to get yours).
- Blitz course in telecomputing.
- Buyer's guide to modems.

Over 400 verified listings. Periodically Updated. On-line Logbook. Electronic Mail Address Book.

\$14.95 P.P. Make checks payable to:
Computer Food Press
Div. of Coltrane & Beach
31754 Foxfield Dr.
Westlake Village, CA 91361
(213) 462-0888



Visa and Mastercard Accepted.



Circle 559 on inquiry card.

TeleCOMM™ — A Complete Versatile, User-friendly & Telecommunicating

ELECTRONIC MAIL

for
TeleVideo®, CP/M®, MP/M®, TurboDOS™ based Computers.

TeleCOMM provides you with the most efficient and cost-effective means of communicating between you and your branch office, coworkers, friends or family via a local area network or nationwide telephone link.

- Multi-User Computers
- Password Protected Transactions
- Broadcasting and Forwarding
- Totally Menu-driven Functions
- Versatile Printing
- Save and Delete Letters
- Assembler Language
- Modem Interface
- Unlimited Users
- Send Letters/Messages/Programs
- Full Screen Editing
- Date Month/Day/Year
- Automatic Prompt for Incoming Mail
- Attractive Video Attributes (Text/Video)

Listed Price: \$498 Special Introductory Price: \$280

TeleWORD™ — WORD PROCESSOR

- CP/M Based & Modem Interface
- Built-in Operating System Commands
- Password Protected Transactions
- Page/Document Forms
- Columnar Processing
- Document Assembly and Merge
- Unlimited Undo Commands
- Screen Editing
- Prompt for Incoming Electronic Mail
- Multitasking (Concurrent Printing)
- Fully Menu-driven Functions
- Horizontal and Vertical Scroll
- Justifications and Indentations
- Calculator Mode
- Mailing List & Label Envelope Printing
- Block Move and Delete

Special Introductory Price: \$98

TurboDOS™ — Free Consulting & Demo. Customized Drivers.

Multuser: \$498

TeleHOST™ — Allows your terminals/Computer to communicate with other computers via telephone links. Price: \$98

TeleLIST™ — Mailing List Program. Prints Labels. Price: \$78

International Computers & Telecommunications, Inc.
932 Hungerford Drive, 16-B, Rockville, MD 20850
(301) 251-0062

Circle 232 on inquiry card.

BG BANK 64S

MAXIMUM FLEXIBILITY!



64K CMOS STATIC RAM LITHIUM BATTERY BACKUP

MPM • CDOS • MULTI-USER
EXTENDED TRACK BUFFERING \$399

✓ SIMULTANEOUS MEMORY ACCESS FEATURES

- 8/16 BIT DATA TRANSFERS • 4 INDEPENDENT 16K X 8 (or 8K X 16) BANKS • ADDRESSABLE ON 16K BOUNDARIES • 2K DESELECTS FOR EACH BANK • 24-BIT EXTENDED ADDRESSING • PHANTOM • RESET ON/OFF • 8 MHz • IEEE 696/S-100 • CROMECO COMPATIBLE

★ DEALER, OEM CALL! 5 BORDS = 7 USERS

OPTION: LITHIUM BATTERY BACKUP: Unique POWER FAIL-SENSE circuit and Lithium battery allows processor to save register information and disable board before POWER FAILURE CRASHES memory (\$39).

BG COMPUTER APPLICATIONS, 206 Brookside, Bryan, Texas 77801. International Orders Add 30%.
(409)-775-5009

Circle 560 on inquiry card.

JDR SUPER SPECIALS!

**THE LEADER IN
COMPUTER
COMPONENTS
BRINGS YOU THESE
FANTASTIC
SUMMERS-END
CLEARANCE BARGAINS**

OKI MSM5832RS

MICROPROCESSOR
COMPATIBLE
CLOCK/CALENDAR CHIP
3.95 100/3.25 ea.
32.768KHZ XTAL .95
OTHER CRYSTALS
3.579545MHZ .95
5.0688MHZ 1.95
18.432MHZ 1.95

78M05

VOLTAGE
REGULATOR
TI PART #UA78M05C
STANDARD TO-220 CASE
5 VOLT AT 500MA CAN BE
USED AS 7805T IN MOST
APPLICATIONS

.29 100/.25 EA.

ORDER TOLL FREE

800 538-5000

800 862-8279

(CA Residents)



CONNECTORS

IDP-16 IDC DIP-PLUG .95
IDE-34 IDC EDGE-CARD 1.95
ICC-14 DIP "HEADER" .49
ICC-16 DIP "HEADER" .59
44P-ST PC EDGE-CARD 1.95
DB25PC/P VERTICAL
PC-MOUNT 1.49
DB25PC/S VERTICAL
PC-MOUNT 1.69

TRANSISTORS

2N3904 TO-92 100/7.95
2N3906 TO-92 100/7.95
PN2222 TO-92 100/7.95

CERAMIC MONOLITHIC CAPS AT THE PRICE OF DISC!

.1UF-MONO 100/12.00
.047UF-MONO 100/11.00
.01UF-MONO 100/10.00

PRIME LED'S

JUMBO RED 100/ 8.00
JUMBO YELLOW 100/12.00
JUMBO GREEN 100/12.00
5082-7760 10/ 7.95

JDR DISK DRIVE BLOW OUTS!

SA 410
\$11995

SA 460
\$14995

★ ½ Mb Storage ★ 1 Mb Storage
★ SS/DD ★ DS/DD

★ 80 Track — 96TPI
★ 6 ms — track to track
★ 5¼" — Standard
Format
★ 90-DAY GUARANTEE

SALE ENDS SEPT. 30, 1983

MICROPROCESSOR

Z80A-CPU 3.95
Z80A-CTC 3.95
Z80A-PIO 3.95
Z80A-SIO/1 12.95
Z80A-DART 6.95
8086 16-BIT 5MHZ 19.95
68A00 CPU 1.5MHZ 2.95
68A10 RAM 1.5MHZ 1.95
68A21 PIA 1.5MHZ 2.95
68A50 ACIA 1.5MHZ 2.95
6520/6820 PIA 2.95

MEMORY

2102L-4 450NS-LP .55
2111L 450NS-LP 1.49
2112 450NS 1.99
2114 450NS .99
2114-25 250NS 1.09
TMS4027 250NS .99

SPECIAL TMS4060/2107

4096 x 1 DYNAMIC
RAMS TI OR INTEL
YOUR CHOICE .69

**SPECIAL THANKS
TO MATT FOR HIS
RECENT SOFTWARE
DEVELOPMENTS
WHICH WILL ENABLE
JDR TO BETTER SERVE
OUR CUSTOMERS**

LINEAR I.C.'S

LM1800 1.95
LM1310 .99
MC1330 .99
MC1350 .89
MC1358 .99

HARD TO FIND BLACK CONDUCTIVE FOAM

14" x 26" SHEET 12.00
12" x 13" SHEET 6.00

DISK CONTROLLERS

1771 11.95
1791 18.95
1793 18.95

CRT CONTROLLERS

DP8350 19.95
CRT5027 9.95
CRT5037 9.95

D-RAM CONTROLLERS

8202 17.95
8203 32.95
3242 5.95

**Visit Our
EXPANDED
Retail Store
NEW SATURDAY
HOURS 10-3**

VISIT OUR RETAIL STORE

HOURS: M-W-F 9-5 T-Th. 9-9 Sat. 10-3

PLEASE USE YOUR CUSTOMER NUMBER WHEN ORDERING
TERMS: For shipping include \$2 for UPS Ground or \$3 for UPS Blue Label Air. Items over 5 pounds require additional shipping charges. Foreign orders, include sufficient amount for shipping. There is a \$10 minimum order. Bay Area and Los Angeles Counties add 6½% Sales Tax. Other California residents add 6% Sales Tax. We reserve the right to substitute manufacturer. Not responsible for typographical errors. Prices are subject to change without notice. We will match or beat any competitor's price provided it is not below our cost.

© 1983 JDR MICRODEVICES, INC.

4164

64K DYNAMIC
200 NS

\$595

TMM2016

2KX8 STATIC
200 NS

\$415

STATIC RAMS

2101	256 x 4 (450ns)	1.95
5101	256 x 4 (450ns) (cmos)	3.95
2102-1	1024 x 1 (450ns)	.89
2102L-4	1024 x 1 (450ns) (LP)	.99
2102L-2	1024 x 1 (250ns) (LP)	1.49
2111	256 x 4 (450ns)	2.49
2112	256 x 4 (450ns)	2.99
2114	1024 x 4 (450ns)	8/9.95
2114-25	1024 x 4 (250ns)	8/10.95
2114L-4	1024 x 4 (450ns) (LP)	8/12.95
2114L-3	1024 x 4 (300ns) (LP)	8/13.45
2114L-2	1024 x 4 (200ns) (LP)	8/13.95
2147	4096 x 1 (55ns)	4.95
TMS4044-4	4096 x 1 (450ns)	3.49
TMS4044-3	4096 x 1 (300ns)	3.99
TMS4044-2	4096 x 1 (200ns)	4.49
MK4118	1024 x 8 (250ns)	9.95
TMM2016-200	2048 x 8 (200ns)	4.15
TMM2016-150	2048 x 8 (150ns)	4.95
TMM2016-100	2048 x 8 (100ns)	6.15
HM6116-4	2048 x 8 (200ns) (cmos)	4.75
HM6116-3	2048 x 8 (150ns) (cmos)	4.95
HM6116-2	2048 x 8 (120ns) (cmos)	8.95
HM6116LP-4	2048 x 8 (200ns) (cmos)(LP)	5.95
HM6116LP-3	2048 x 8 (150ns) (cmos)(LP)	6.95
HM6116LP-2	2048 x 8 (120ns) (cmos)(LP)	10.95
Z-6132	4096 x 8 (300ns) (Qstat)	34.95

LP = Low Power Qstat = Quasi-Static

DYNAMIC RAMS

TMS4027	4096 x 1 (250ns)	1.99
UPD411	4096 x 1 (300ns)	3.00
MM5280	4096 x 1 (300ns)	3.00
MK4108	8192 x 1 (200ns)	1.95
MM5298	8192 x 1 (250ns)	1.85
4116-300	16384 x 1 (300ns)	8/11.75
4116-250	16384 x 1 (250ns)	8/11.95
4116-200	16384 x 1 (200ns)	8/12.95
4116-150	16384 x 1 (150ns)	8/14.95
4116-120	16384 x 1 (120ns)	8/29.95
2118	16384 x 1 (150ns) (5v)	4.95
4164-200	65536 x 1 (200ns) (5v)	5.95
4164-150	65536 x 1 (150ns) (5v)	6.95

5V - single 5 volt supply

EPROMS

1702	256 x 8 (1us)	4.50
2708	1024 x 8 (450ns)	3.95
2758	1024 x 8 (450ns) (5v)	5.95
2716	2048 x 8 (450ns) (5v)	3.95
2716-1	2048 x 8 (350ns) (5v)	5.95
TMS2516	2048 x 8 (450ns) (5v)	5.50
TMS2716	2048 x 8 (450ns)	7.95
TMS2532	4096 x 8 (450ns) (5v)	5.95
2732	4096 x 8 (450ns) (5v)	4.95
2732-250	4096 x 8 (250ns) (5v)	8.95
2732-100	4096 x 8 (200ns) (5v)	11.95
2764	8192 x 8 (450ns) (5v)	9.95
2764-250	8192 x 8 (250ns) (5v)	14.95
2764-200	8192 x 8 (200ns) (5v)	24.95
TMS2564	8192 x 8 (450ns) (5v)	17.95
MC68764	8192 x 8 (450ns) (5v)(24 pin)	39.95
27128	16384x8 Call	Call

5v - Single 5 Volt Supply

EPROM ERASERS

	Timer	Capacity Chip	Intensity (uW/Cm ²)	
PE-14		6	5,200	83.00
PE-14T	X	6	5,200	119.00
PE-24T	X	9	6,700	175.00
PL-265T	X	20	6,700	255.00
PR-125T	X	16	15,000	349.00
PR-320	X	32	15,000	595.00

Z-80

2.5 Mhz	
Z80-CPU	3.95
Z80-CTC	4.49
Z80-DART	10.95
Z80-DMA	14.95
Z80-PIO	4.49
Z80-SIO/0	16.95
Z80-SIO/1	16.95
Z80-SIO/2	16.95
Z80-SIO/9	16.95

4.0 Mhz

Z80A-CPU	4.95
Z80A-CTC	4.95
Z80A-DART	11.95
Z80A-DMA	16.95
Z80A-PIO	4.95
Z80A-SIO/0	16.95
Z80A-SIO/1	16.95
Z80A-SIO/2	16.95
Z80A-SIO/9	16.95

6.0 Mhz

Z80B-CPU	11.95
Z80B-CTC	13.95
Z80B-PIO	13.95
Z80B-DART	19.95

ZILOG

Z6132	34.95
Z8671	39.95

CRYSTALS

32.768 khz	1.95
1.0 mhz	4.95
1.8432	4.95
2.0	3.95
2.097152	3.95
2.4576	3.95
3.2768	3.95
3.579535	3.95
4.0	3.95
5.0	3.95
5.0688	3.95
5.185	3.95
5.7143	3.95
6.0	3.95
6.144	3.95
6.5536	3.95
8.0	3.95
10.0	3.95
10.738635	3.95
14.31818	3.95
15.0	3.95
16.0	3.95
17.430	3.95
18.0	3.95
18.432	3.95
20.0	3.95
22.1184	3.95
32.0	3.95

CRT CONTROLLERS

6845	14.95
68B45	19.95
HD46505SP	15.95
6847	11.95
MC1372	6.95
68047	24.95
8275	29.95
7220	99.95
CRT5027	39.95
CRT5037	49.95
TMS9918A	39.95
DP8350	49.95

KEYBOARD CHIPS

AY5-2376	11.95
AY5-3600	11.95
AY5-3600 PRO	11.95

8000

8035	5.95
8039	6.95
INS-8060	17.95
INS-8073	24.95
8080	3.95
8085	5.95
8085A-2	11.95
8086	29.95
8087	CALL
8088	39.95
8089	89.95
8155	6.95
8155-2	7.95
8156	6.95
8185	29.95
8185-2	39.95
8741	39.95
8748	24.95
8755	24.95

8200

8202	24.95
8203	39.95
8205	3.50
8212	1.80
8214	3.85
8216	1.75
8224	2.25
8226	1.80
8228	3.49
8237	19.95
8237-5	21.95
8238	4.49
8243	4.45
8250	10.95
8251	4.49
8253	6.95
8253-5	7.95
8255	4.49
8255-5	5.25
8257	7.95
8257-5	8.95
8259	6.90
8259-5	7.50
8271	39.95
8272	39.95
8275	29.95
8279	8.95
8279-5	10.00
8282	6.50
8283	6.50
8284	5.50
8286	6.50
8287	6.50
8288	25.00
8289	49.95

DISC CONTROLLERS

1771	16.95
1791	24.95
1793	26.95
1795	49.95
1797	49.95
2791	54.95
2793	54.95
2795	59.95
2797	59.95
6843	34.95
8272	39.95
UPD765	39.95
MB8876	29.95
MB8877	34.95
1691	17.95
2143	18.95

CONNECTORS

RS232 MALE	2.50
RS232 FEMALE	3.25
RS232 HOOD	1.25
S-100 ST	3.95

6800

68000	59.95
6800	3.95
6802	7.95
6808	13.90
6809E	19.95
6809	11.95
6810	2.95
6820	4.35
6821	3.25
6828	14.95
6840	12.95
6843	34.95
6844	25.95
6845	14.95
6847	11.95
6850	3.25
6852	5.75
6860	9.95
6862	11.95
6875	6.95
6880	2.25
6883	22.95
68047	24.95
68488	19.95

6800 - 1MHZ

68B00	10.95
68B02	22.25
68B09E	29.95
68B09	29.95
68B10	6.95
68B21	6.95
68B45	19.95
68B50	5.95

6800 - 2MHZ

68B00	10.95
68B02	22.25
68B09E	29.95
68B09	29.95
68B10	6.95
68B21	6.95
68B45	19.95
68B50	5.95

6500

1 MHZ	
6502	4.95
6504	6.95
6505	8.95
6507	9.95
6520	4.35
6522	7.95
6532	9.95
6545	22.50
6551	11.85
2 MHZ	
6502A	6.95
6522A	9.95
6532A	11.95
6545A	27.95
6551A	11.95
3 MHZ	
6502B	14.95

UARTS

AY3-1014	6.95
AY5-1013	3.95
AY3-1015	6.95
PT1472	9.95
TR1602	3.95
2350	9.95
2651	8.95
TMS6011	5.95
IM6402	7.95
IM6403	8.95
INS8250	10.95
74LS100	3.95
74LS101	3.95
74LS102	3.95
74LS103	3.95
74LS104	3.95
74LS105	3.95
74LS106	3.95
74LS107	3.95
74LS108	3.95
74LS109	3.95
74LS110	3.95
74LS111	3.95
74LS112	3.95
74LS113	3.95
74LS114	3.95
74LS115	3.95
74LS116	3.95
74LS117	3.95
74LS118	3.95
74LS119	3.95
74LS120	3.95
74LS121	3.95
74LS122	3.95
74LS123	3.95
74LS124	3.95
74LS125	3.95
74LS126	3.95
74LS127	3.95
74LS128	3.95
74LS129	3.95
74LS130	3.95
74LS131	3.95
74LS132	3.95
74LS133	3.95
74LS134	3.95
74LS135	3.95
74LS136	3.95
74LS137	3.95
74LS138	3.95
74LS139	3.95
74LS140	3.95
74LS141	3.95
74LS142	3.95
74LS143	3.95
74LS144	3.95
74LS145	3.95
74LS146	3.95
74LS147	3.95
74LS148	3.95
74LS149	3.95
74LS150	3.95
74LS151	3.95
74LS152	3.95
74LS153	3.95
74LS154	3.95
74LS155	3.95
74LS156	3.95
74LS157	3.95
74LS158	3.95
74LS159	3.95
74LS160	3.95
74LS161	3.95
74LS162	3.95
74LS163	3.95
74LS164	3.95
74LS165	3.95
74LS166	3.95
74LS167	3.95
74LS168	3.95
74LS169	3.95
74LS170	3.95

GENERATORS BIT-RATE

MC14411	11.95
BR1941	11.95
4702	12.95
COM5016	16.95
COM8116	10.95
MM5307	10.95

FUNCTION

MC4024	3.95
LM566	1.49
XR2206	3.75
8038	3.95

74LS00

74LS00	.24	74LS173	.69
74LS01	.25	74LS174	.55
74LS02	.25	74LS175	.5

2114

450 NS

8/\$995

2114

250 NS

8/\$1095

7400

'400	.19	74132	.45
'401	.19	74136	.50
'402	.19	74141	.65
'403	.19	74142	2.95
'404	.19	74143	2.95
'405	.25	74145	.60
'406	.29	74147	1.75
'407	.29	74148	1.20
'408	.24	74150	1.35
'409	.19	74151	.55
'410	.19	74152	.65
'411	.25	74153	.55
'412	.30	74154	1.25
'413	.35	74155	.75
'414	.49	74156	.65
'416	.25	74157	.55
'417	.25	74159	1.65
'420	.19	74160	.85
'421	.35	74161	.69
'422	.35	74162	.85
'423	.29	74163	.69
'425	.29	74164	.85
'426	.29	74165	.85
'427	.29	74166	1.00
'428	.45	74167	2.95
'430	.19	74170	1.65
'432	.29	74172	5.95
'433	.45	74173	.75
'437	.29	74174	.89
'438	.29	74175	.89
'440	.19	74176	.89
'442	.49	74177	.75
'443	.65	74178	1.15
'444	.69	74179	1.75
'445	.69	74180	.75
'446	.69	74181	2.25
'447	.69	74182	.75
'448	.69	74184	2.00
'450	.19	74185	2.00
'451	.23	74190	1.15
'453	.23	74191	1.15
'454	.23	74192	.79
'460	.23	74193	.79
'470	.35	74194	.85
'472	.29	74195	.85
'473	.34	74196	.79
'474	.33	74197	.75
'475	.45	74198	1.35
'476	.35	74199	1.35
'480	.59	74221	1.35
'481	1.10	74246	1.35
'482	.95	74247	1.25
'483	.50	74248	1.85
'485	.59	74249	1.95
'486	.35	74251	.75
'489	2.15	74259	2.25
'490	.35	74265	1.35
'491	.40	74273	1.95
'492	.50	74276	1.25
'493	.35	74279	.75
'494	.65	74283	2.00
'495	.55	74284	3.75
'496	.70	74285	3.75
'497	2.75	74290	.95
'4100	1.75	74293	.75
'4107	.30	74298	.85
'4109	.45	74351	2.25
'4110	.45	74365	.65
'4111	.55	74366	.65
'4116	1.55	74367	.65
'4120	1.20	74368	.65
'4121	.29	74376	2.20
'4122	.45	74390	1.75
'4123	.49	74393	1.35
'4125	.45	74425	3.15
'4126	.45	74426	.85
'4128	.55	74490	2.55

LINEAR

LM301	.34	LM340 (see 7800)	LM566	1.49	LM1800	2.37
LM301H	.79	LM348	LM567	.89	LM1812	8.25
LM307	.45	LM350K	NE570	3.95	LM1830	3.50
LM308	.69	LM350T	NE571	2.95	LM1871	5.49
LM308H	1.15	LM358	NE592	2.75	LM1872	5.49
LM309H	1.95	LM359	LM709	.59	LM1877	3.25
LM309K	1.25	LM376	LM710	.75	LM1889	1.95
LM310	1.75	LM377	LM711	.79	LM1896	1.95
LM311	.64	LM378	LM723	.49	ULN2003	2.49
LM311H	.89	LM379	LM723H	.55	LM2877	2.05
LM312H	1.75	LM380	LM733	.98	LM2878	2.25
LM317K	3.95	LM380N-8	LM741	.35	LM2900	.85
LM317T	1.19	LM381	LM741N-14	.35	LM2901	1.00
LM318	1.49	LM382	LM741H	.40	LM3900	.59
LM318H	1.59	LM383	LM747	.69	LM3905	1.25
LM319H	1.90	LM384	LM748	.59	LM3909	.98
LM319	1.25	LM386	LM1014	1.19	LM3911	2.25
LM320 (see 7900)	LM387	1.40	LM1303	1.95	LM3914	3.95
LM322	1.65	LM389	LM1310	1.49	LM3915	3.95
LM323K	4.95	LM390	MC1330	1.69	LM3916	3.95
LM324	.59	LM392	MC1349	1.89	MC4024	3.95
LM329	.65	LM394H	MC1350	1.19	MC4044	4.50
LM331	3.95	LM399H	MC1358	1.69	RC4136	1.25
LM334	1.19	NE531	MC1372	6.95	RC4151	3.95
LM335	1.40	NE555	LM1414	1.59	LM4250	1.75
LM336	1.75	NE556	LM1458	.59	LM4500	3.25
LM337K	3.95	NE558	LM1488	.69	RC4558	.69
LM337T	1.95	NE561	LM1489	.69	LM13080	1.29
LM338K	6.95	NE564	LM1496	.85	LM13600	1.49
LM339	.99	LM565	LM1558H	3.10	LM13700	1.49

H = TO-5 CAN

T = TO-220

K = TO-3

RCA

CA 3023	2.75	CA 3082	1.65
CA 3039	1.29	CA 3083	1.55
CA 3046	1.25	CA 3086	.80
CA 3059	2.90	CA 3089	2.99
CA 3060	2.90	CA 3096	3.49
CA 3065	1.75	CA 3130	1.30
CA 3080	1.10	CA 3140	1.15
CA 3081	1.65	CA 3146	1.85
CA 3160	1.19		

TI

TL494	4.20	75365	1.95
TL496	1.65	75450	.59
TL497	3.25	75451	.39
75107	1.49	75452	.39
75110	1.95	75453	.39
75150	1.95	75454	.39
75154	1.95	75491	.79
75188	1.25	75492	.79
75189	1.25	75493	.89
75494	.89		

BI FET

TL071	.79	TL084	2.19
TL072	1.19	LF347	2.19
TL074	2.19	LF351	.60
TL081	.79	LF353	1.00
TL082	1.19	LF355	1.10
TL083	1.19	LF356	1.10
LF357	1.40		

74S00

74S00	.32	74S163	1.95
74S02	.35	74S168	3.95
74S03	.35	74S169	3.95
74S04	.35	74S174	.95
74S05	.35	74S175	.95
74S08	.35	74S181	3.95
74S09	.40	74S182	2.95
74S10	.35	74S188	1.95
74S11	.35	74S189	6.95
74S15	.35	74S194	1.49
74S20	.35	74S195	1.49
74S22	.35	74S196	1.49
74S30	.35	74S197	1.49
74S32	.40	74S201	6.95
74S37	.88	74S225	7.95
74S38	.85	74S240	2.20
74S40	.35	74S241	2.20
74S51	.35	74S244	2.20
74S64	.40	74S251	.95
74S65	.40	74S253	.95
74S74	.50	74S257	.95
74S85	1.99	74S258	.95
74S86	.50	74S260	.79
74S112	.50	74S274	19.95
74S113	.50	74S275	19.95
74S114	.55	74S280	1.95
74S124	2.75	74S287	1.90
74S132	1.24	74S288	1.90
74S133	.45	74S289	6.89
74S134	.50	74S301	6.95
74S135	.89	74S373	2.45
74S138	.85	74S374	2.45
74S139	.85	74S381	7.95
74S140	.55	74S387	1.95
74S151	.95	74S412	2.98
74S153	.95	74S471	4.95
74S157	.95	74S472	4.95
74S158	.95	74S474	4.95
74S161	1.95	74S482	15.25
74S162	1.95	74S570	2.95
		74S571	2.95

INTERFACE

8T26	1.59
8T28	1.89
8T95	.89
8T96	.89
8T97	.89
8T98	.89
DM8131	2.95
DP8304	2.29
DS8835	1.99
DS8836	.99

MISC.

TMS99532	29.95
ULN2003	2.49
3242	7.95
3341	4.95
MC3470	4.95
MC3480	9.00
11C90	13.95
95H90	7.95
2513-001 LP	9.95
2513-002 LOW	9.95

VOLTAGE REGULATORS

7805T	.75	7905T	.85
78MO5C	.35	7908T	.85
7808T	.75	7912T	.85
7812T	.75	7915T	.85
7815T	.75	7924T	.85
7824T	.75		
7805K	1.39	7905K	1.49
7812K	1.39	7912K	1.49
7815K	1.39	7915K	1.49
7824K	1.39	7924K	1.49
78L05	.69	79L05	.79
78L12	.69	79L12	.79
78L15	.69	79L15	.79
78H05K	9.95	LM323K	4.95
78H12K	9.95	UA78S40	1.95

C, T = TO-220 K = TO-3 L = TO-92

IF YOU CAN FIND A PRICE LOWER ELSEWHERE, LET US KNOW AND WE WILL MEET OR BEAT THEIR PRICE! (SEE TERMS BELOW)

- * Computer managed inventory — virtually no back orders!
- * Very competitive prices!
- * Friendly staff!
- * Fast service — most orders shipped within 24 hours!

CLOCK CIRCUITS

MM5314	4.95
MM5369	3.95
MM5375	4.95
MM58167	8.95
MM58174	11.95
MSM5832	6.95

INTERSIL

ICL7106	9.95
ICL7107	12.95
ICL7660	2.95
ICL8038	3.95
ICM7207A	5.59
ICM7208	15.95

9000

9316	1.00
9334	2.50
9368	3.95
9401	9.95
9601	.75
9602	1.50
96S02	1.95

EXAR

XR 2206	3.75
XR 2207	3.75
XR 2208	3.75
XR 2211	5.25
XR 2240	3.25

DATA ACQUISITION

ADC0800	15.55	DAC0808	2.95
ADC0804	3.49	DAC1020	8.25
ADC0809	4.49	DAC1022	5.95
ADC0817	9.95	MC1408L6	1.95
DAC0800	4.95	MC1408L8	2.95

SOUND CHIPS

76477	3.95
76489	8.95
AY3-8910	12.95
AY3-8912	12.95
MC3340	1.49

**ORDER TOLL FREE
ALL MERCHANDISE
100% GUARANTEED**



800-538-5000

800-662-6279 (CALIFORNIA RESIDENTS)

CALL US FOR VOLUME QUOTES

© 1983 JDR MICRODEVICES, INC.

2732 32K EPROM

\$495

2764 64K EPROM

\$995

PROMS

Order by National Part	Function	EQUIVALENT PART NUMBERS				Price
		TI	SIG	MIMI	Harris	
74S188	32x8 OC	18SA030	82S23	6330-1	7602	1.95
74S287	256x4 TS	24S10	82S129	6301-1	7611	1.90
74S288	32x8 TC	18S030	82S123	6331-1	7603	1.90
74S387	256x4 OC	24SA10	82S126	6300-1	7610	1.95
74S471	256x8 TS	28L22		6309-1		4.95
74S472	512x8 TS	28S42	82S147	6349-1	7649	4.95
74S473	512x8 OC	28SA42	82S146	6348	7648	10.95
74S474	512x8 TS	28S46	82S141	6341	7641	4.95
74S475	512x8 TS	28SA46	82S140	6340	7640	12.95
74S478	1Kx8 TS	28S86				19.95
74S570	512x4 OC	27S12	82S130	6305	7620	2.95
74S571	512x4 TS	27S13	82S131	6306-1	7621	2.95
74S572	1Kx4 OC	24SA41	82S136	6352-1	7642	9.95
74S573	1Kx4 TS	24S41	82S137	6353-1	7643	9.95
87S180	1Kx8 OC	28SA86	82S180	6380-1	7680	19.25
87S181	1Kx8 TS	28L86	82S181	6381-1	7681	16.25
87S184	2Kx4 OC	24SA81	82S184		7684	17.20
87S185	2Kx4 TS	24S81	82S185		7685	16.95
87S190	2Kx4 OC	28SA166	82S190		76160	39.95
87S191	2Kx8 TS	28S166	82S191		76161	39.95

WE RESERVE THE RIGHT TO SUBSTITUTE MANUFACTURER

CAPACITORS

TANTALUM	6V 10V 15V 20V 25V 35V 50V						
	.22uf						.40
.27						.40	
.33						.40	.45
.47			.35				.50
.68						.45	.50
1.0		.40	.40	.45	.45		
1.5			.45		.50	.60	
1.8							.75
2.2		.35	.40	.45		.65	.85
2.7		.40	.45				.90
3.3		.45	.50	.55	.60	.65	.90
3.9		.45					
4.7	.45	.55	.60	.65	.85	.90	
6.8			.70		.75		
8.2							1.00
10	.55	.65	.80	.85	.90	1.00	
12	.65		.85	.90			
15	.75	.85	.90				
18			1.25				
22		1.00	1.35				
27			2.25				
39		1.50					
47	1.35						
56	1.75						
100		3.25					
270	3.75						

DISC

10pf	50V	.05	470	50V	.05
22	50V	.05	560	50V	.05
25	50V	.05	680	50V	.05
27	50V	.05	820	50V	.05
33	50V	.05	.001uf	50V	.05
47	50V	.05	.0015	50V	.05
56	50V	.05	.0022	50V	.05
68	50V	.05	.005	50V	.05
82	50V	.05	.01	50V	.07
100	50V	.05	.02	50V	.07
220	50V	.05	.05	50V	.07
330	50V	.05	.1	12V	.10
			.1	50V	.12

MONOLITHIC

.1uf-mono	50V	.18	.47uf-mono	50V	.25
-----------	-----	-----	------------	-----	-----

ELECTROLYTIC

RADIAL		AXIAL			
.47uf	50V	.14	1uf	50V	.14
1	25V	.14	4.7	16V	.14
2.2	35V	.15	10	16V	.14
4.7	50V	.15	10	50V	.16
10	50V	.15	22	16V	.14
47	35V	.18	47	50V	.20
100	16V	.18	100	15V	.20
220	35V	.20	100	35V	.25
470	25V	.30	150	25V	.25
2200	16V	.60	220	25V	.30
			330	16V	.40
			500	16V	.42
			1000	16V	.60
			1500	16V	.70
			6000	16V	.85

COMPUTER GRADE

26,000uf	30V	3.95
----------	-----	------

ORDER 800-538-5000
TOLL FREE 800-662-6279
(CALIFORNIA RESIDENTS)

OPTO-ISOLATORS

4N26	1.00	MCA-7	4.25
4N27	1.10	MCA-255	1.75
4N28	.69	IL-1	1.25
4N33	1.75	ILA-30	1.25
4N35	1.25	ILQ-74	2.75
4N37	1.25	H11C5	1.25
MCT-2	1.00	TIL-111	1.00
MCT-6	1.50	TIL-113	1.75

FEDERAL EXPRESS SERVICES AVAILABLE

TRANSISTORS

2N918	.50	MPS3706	.15
MPS918	.25	2N3772	1.85
2N2102	.75	2N3903	.25
2N2218	.50	2N3904	.10
2N2218A	.50	2N3906	.10
2N2219	.50	2N4122	.25
2N2219A	.50	2N4123	.25
2N2222	.25	2N4249	.25
PN2222	.10	2N4304	.75
MPS2369	.25	2N4401	.25
2N2484	.25	2N4402	.25
2N2905	.50	2N4403	.25
2N2907	.25	2N4857	1.00
PN2907	.125	PN4916	.25
2N3055	.79	2N5086	.25
3055T	.69	PN5129	.25
2N3393	.30	PN5139	.25
2N3414	.25	2N5209	.25
2N3563	.40	2N6028	.35
2N3565	.40	2N6043	1.75
PN3565	.25	2N6045	1.75
MPS3638	.25	MPS-A05	.25
MPS3640	.25	MPS-A06	.25
PN3643	.25	MPS-A55	.25
PN3644	.25	TIP29	.65
MPS3704	.15	TIP31	.75
		TIP32	.79

IC SOCKETS

8 pin ST	1-99	100
14 pin ST	.13	.11
16 pin ST	.15	.12
18 pin ST	.17	.13
20 pin ST	.20	.18
22 pin ST	.29	.27
24 pin ST	.30	.27
28 pin ST	.40	.32
40 pin ST	.49	.39
64 pin ST	4.25	call
ST = SOLDERTAIL		
8 pin WW	.59	.49
14 pin WW	.69	.52
16 pin WW	.69	.58
18 pin WW	.99	.90
20 pin WW	1.09	.98
22 pin WW	1.39	1.28
24 pin WW	1.49	1.35
28 pin WW	1.69	1.49
40 pin WW	1.99	1.80
WW = WIREWRAP		
16 pin ZIF	6.75	call
24 pin ZIF	9.95	call
28 pin ZIF	10.95	call
ZIF = TEXTTOOL (Zero Insertion Force)		



LED LAMPS

Jumbo Red	1-99	100-uf	.09
Jumbo Green	.18	.15	
Jumbo Yellow	.18	.15	

DIODES

1N751	5.1 volt zener	.25
1N759	12.0 volt zener	.25
1N4148	(1N914) switching	25/1.00
1N4004	400PIV rectifier	10/1.00
KBPO2	200PIV 1.5amp bridge	.45
KBPO4	400PIV 1.5amp bridge	.55
VM48	Dip-Bridge	.35

MUFFIN FANS NEW UN-USED

4.68" Square	14.95
3.125" Square	14.95

HEAT SINKS

TO-3 style	.95
TO-220 style	.35

SWITCHES

SPDT mini-toggle	1.25
DPDT mini-toggle	1.50
SPST mini-pushbutton	.39

BYPASS CAPS

.01 UF DISC	100/6.00
.1 UF DISC	100/8.00
.1 UF MONOLITHIC	100/15.00

LED DISPLAYS

HP 5082-7760	.6"	CC	1.29
MAN 72	.3"	CA	.99
MAN 74	.3"	CC	.99
FND-357 (359)	.375"	CC	1.25
FND-500 (503)	.5"	CC	1.49
FND-507 (51Q)	.5"	CA	1.49

DIP SWITCHES

4 POSITION	.85
5 POSITION	.90
6 POSITION	.90
7 POSITION	.95
8 POSITION	.95

RESISTORS

1/4 WATT 5% CARBON FILM ALL STANDARD VALUES FROM 1 OHM TO 10 MEG OHM
50 PCS. SAME VALUE .025
100 PCS. SAME VALUE .02
1000 PCS. SAME VALUE .015

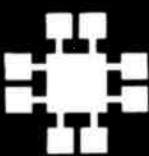

JDR Microdevices

1224 S. Bascom Avenue
San Jose, CA 95128
800-538-5000 • 800-662-6279 (CA)
(408) 995-5430 • Telex 171-110

VISIT OUR RETAIL STORE — NEW HOURS —
M-W-F, 9-5
T-Th., 9-9 Sat. 11-3

PLEASE USE YOUR CUSTOMER NUMBER WHEN ORDERING

TERMS: For shipping include \$2 for UPS Ground or \$3 for UPS Blue Label Air. Items over 5 pounds require additional shipping charges. Foreign orders, include sufficient amount for shipping. There is a \$10 minimum order. Bay Area and Los Angeles Counties add 6 1/4% Sales Tax. Other California residents add 6% Sales Tax. We reserve the right to substitute manufacturer. Not responsible for typographical errors. Prices are subject to change without notice. We will match or beat any competitor's price provided it is not below our cost.

1983 JDR MICRODEVICES, INC.

2716

16K EPROMS

\$395 EACH

2732

32K EPROMS

\$495 EACH

MICROCOMPUTER HARDWARE HANDBOOK FROM ELCOMP — \$14.95

Over 800 pages of manufacturers data sheets on most commonly used IC's.

Includes:

- * TTL — 74/74LS and 74F
- * CMOS
- * Voltage Regulators
- * Memory — RAM, ROM, EPROM
- * CPU's — 6800, 6500, Z80, 8080, 8085, 8086/8
- * MPU support & interface — 6800, 6500, Z80, 8200, etc.

DISK DRIVES TANDON

TM100-1 5 1/4" (FOR IBM) SS/DD 229.00

TM100-2 5 1/4" (FOR IBM) DS/DD 295.00

SHUGART

SA 400L 5 1/4" (40 TRACK) SS/DD 199.95

SA 400 5 1/4" (35 TRACK) SS/DD 189.95

PERTEC

FD-200 5 1/4" SS/DD 179.95

FD-250 5 1/4" DS/DD 199.95

MPI

MP-52 5 1/4" (FOR IBM) DS/DD 295.00

NOTE: Please include sufficient amount for shipping on above items.

8" DRIVE SALE

FD100-8 \$189

SHUGART 801 EQUIVALENT
SS/DD 10 FOR \$175 EA.

FD200-8 \$239

SHUGART 851 EQUIVALENT
DS/DD 10 FOR \$220 EA.

BEST SELLING BOOKS

OSBORNE/MC GRAW-HILL

- Apple II User's Guide 16.95
- CRT Controller's Handbook 9.95
- 68000 Assembly Language Programming 16.99
- CBASIC User Guide 15.00

SYBEX

- Your First Computer 8.95
- The CP/M Handbook 14.95
- The PASCAL Handbook 18.95
- Microprocessor Interfacing Techniques 17.95

CABINETS FOR 5 1/4" DISK DRIVES

CABINET #1 \$29.95

- * DIMENSIONS 8 3/8" x 5 1/16" x 3 1/16"
- * COLOR MATCHES APPLE
- * FITS STANDARD 5 1/4" DRIVES, INCL. SHUGART
- * INCLUDES MOUNTING HARDWARE AND FEET

CABINET #2 \$79.00

- * COMPLETE WITH POWER SUPPLY, SWITCH, LINE CORD, FUSE & STANDARD POWER CONNECTOR
- * DIMENSIONS: 11 1/2" x 5 3/4" x 3 1/16"
- * +5V @ 1 AMP, +12V @ 1.5 AMP
- * FITS STANDARD 5 1/4" DRIVES
- * PLEASE SPECIFY GRAY OR TAN

NOTE: Please include sufficient amount for shipping on above items.

EDGE-CARD CONNECTORS

- S-100 ST 3.95
- S-100 WW 4.95
- 72 pin ST 6.95
- 72 pin WW 7.95
- 50 pin ST 4.95
- 44 pin ST 2.95
- 44 pin WW 4.95
- 44 pin SE 3.95

TRANSFORMERS

FRAME STYLE

- 12.6VAC 2amp 4.95
- 12.6VAC CT 2amp 5.95
- 12.6VAC CT 4amp 7.95
- 12.6VAC CT 8amp 10.95
- 25.2VAC CT 2amp 7.95

PLUG CASE STYLE

- 12VAC 250ma 3.95
- 12VAC 500ma 4.95
- 12VAC 1amp 5.95
- 12VAC 2amp 6.95

DC ADAPTER

- 6, 9, 12 VDC selectable with universal adapter 8.95

NOTE: Please include sufficient amount for shipping on above items.

DIP CONNECTORS

DESCRIPTION	HIGH RELIABILITY TOOLED ST IC SOCKETS	COMPONENT CARRIERS (DIP HEADERS)	RIBBON CABLE DIP PLUGS (IDC)
ORDER BY	AUGATxx-ST	ICCxx	IDPxx
CONTACTS 8	.99	.65	
14	.99	.75	1.45
16	.99	.85	1.65
18	1.69	1.00	
20	1.89	1.25	
22	1.89	1.25	
24	1.99	1.35	2.50
28	2.49	1.50	
40	2.99	2.10	4.15

For order instructions see "IDC Connectors" below.

POWER SUPPLY

MODEL 2 \$3995

MOUNTED ON PC BOARD
MANUFACTURED BY CONVER

+5 VOLT 4 AMP

±12 VOLT 1 AMP

NOTE: Please include sufficient amount for shipping on above items.

CENTRONICS

- IDCEN36 Ribbon Cable 36 Pin Male 8.95
- CEN36 Solder Cup 36 Pin Male 7.95

RIBBON CABLE

CONTACTS	SINGLE COLOR		COLOR CODED	
	1'	10'	1'	10'
10	50	4.40	.83	7.30
16	55	4.80	1.00	8.80
20	65	5.70	1.25	11.00
25	75	6.60	1.32	11.60
26	75	6.60	1.32	11.60
34	98	8.60	1.65	14.50
40	1.32	11.60	1.92	16.80
50	1.38	12.10	2.50	22.00

D-SUBMINIATURE

DESCRIPTION	SOLDER CUP		RIGHT ANGLE PC SOLDER		IDC RIBBON CABLE		HOODS	
	MALE	FEMALE	MALE	FEMALE	MALE	FEMALE	BLACK	GREY
ORDER BY	DBxxP	DBxxS	DBxxPR	DBxxSR	IDBxxP	IDBxxS	HOOD-B	HOOD
CONTACTS 9	2.08	2.66	1.65	2.18	3.37	3.69	---	1.60
15	2.69	3.63	2.20	3.03	4.70	5.13	---	1.60
25	2.50	3.25	3.00	4.42	6.23	6.84	1.25	1.25
37	4.80	7.11	4.83	6.19	9.22	10.08	---	2.95
50	6.06	9.24	---	---	---	---	---	3.50

For order instructions see "IDC Connectors" below.

CALL FOR MOUNTING HARDWARE

IDC CONNECTORS

DESCRIPTION	SOLDER HEADER	RIGHT ANGLE SOLDER HEADER	WW HEADER	RIGHT ANGLE WW HEADER	RIBBON HEADER SOCKET	RIBBON HEADER	RIBBON EDGE CARD
ORDER BY	IDHxxS	IDHxxSR	IDHxxW	IDHxxWR	IDSxx	IDMxx	IDExx
CONTACTS 10	.82	.85	1.86	2.05	1.15	---	2.25
20	1.29	1.35	2.98	3.28	1.86	5.50	2.36
26	1.68	1.76	3.84	4.22	2.43	6.25	2.65
34	2.20	2.31	4.50	4.45	3.15	7.00	3.25
40	2.58	2.72	5.28	4.80	3.73	7.50	3.80
50	3.24	3.39	6.63	7.30	4.65	8.50	4.74

ORDERING INSTRUCTIONS: Insert the number of contacts in the position marked "xx" of the "order by" part number listed. Example: A 10 pin right angle solder style header would be IDH10SR.

FOR APPLE COMPUTER USERS

FD-35 DISK DRIVE

- ★ Direct Replacement for Apple Disk II
- ★ Compatible with Apple Controller or other Apple compatible controllers
- ★ Specially designed electronics with **low power consumption**
- ★ DOS 3.3 and 3.2 compatible
- ★ Owner's Manual and Warranty Card included

NOW
WITH ONE YEAR WARRANTY \$229⁹⁵
 CONTROLLER CARD \$89.95

VIEWMAX-80

A Full Function
 80 Column Card for Apple II*
 ★ Soft Video Switch ★ Shift Key Support
2 YEAR WARRANTY
 NOW ONLY \$189⁹⁵

5 1/4" DISKETTES VERBATIM DATALIFE

SS/DD SOFT SECTOR 29.95
 SS/DD 10 SECTOR HEAD 29.95
NASHUA
 SS/DD SOFT SECTOR
 WITH HUB RING \$19⁹⁵
BEST BUY
 Ask about our full
 line of Nashua diskettes

THOUSANDS SOLD JDR 16K RAMCARD

- ★ Expand your 48K Apple to 64K
- ★ Fully compatible with Apple Language System — Use in place of Apple Language card
- ★ Provides extra memory for Visicalc™
- ★ Run PASCAL, FORTRAN, Integer Basic with appropriate software
- ★ Highest quality card features: gold edge connector, sockets for all IC's

WITH 2 YEAR WARRANTY
 ASSEMBLED & TESTED
 WITH WARRANTY \$44⁹⁵
 KIT — INCLUDES ALL
 PARTS & INSTRUCTIONS \$40⁹⁵
 BARE PC CARD
 WITH INSTRUCTIONS \$14⁹⁵

APPLE COMPATIBLE POWER SUPPLY \$99.95

- ★ Compact Switching Design
- ★ All Outputs regulated
- ★ Short Circuit and Overload Protection
- ★ Complete with Apple-type plug-in power cord
- ★ Apple Compatible — Yet higher output allows more disk drives and cards without overheating
- ★ +5V @ 5A, +12V @ 3A, -5V @ .5A, -12V @ .5A
- ★ Shielded enclosure: 10 3/4" x 3 1/2" x 2 1/16"

NEW IMPROVED JDR COOLING FAN

- ★ Easy modification — no modification of Apple required
- ★ Eliminates overheating problems
- ★ Switch on front controls fan, Apple, and extra outlet
- ★ Rotron whisper fan is the quietest, most reliable on the market

**NOW WITH SURGE
 SUPPRESSION**
\$69.95
 WITHOUT SURGE
 SUPPRESSION \$59.95

MONITORS MONOCHROME

NEC JB1201M - 20 MHZ GREEN \$169
 ZENITH ZUM-121 - 15 MHZ GREEN \$99
 TAXAN 18 MHZ AMBER \$139
COLOR
 AMDEK COLOR I - COMPOSITE \$335
 NO C.O.D. ORDERS PLEASE

ORDER TOLL FREE
800-538-5000
800-662-6279
 (CALIFORNIA RESIDENTS)

ACCESSORIES FOR APPLE II & IIE

ALL WITH 1 YEAR WARRANTY BY



PRINTERLINK CENTRONICS PARALLEL INTERFACE

- ★ Simple to use — No configuring required
- ★ Use with any centronics printer — EPSON, OKIDATA, etc.
- ★ Includes Cable & Manual

\$59⁰⁰

MESSENGER SERIAL INTERFACE

- ★ Connects to any RS-232 serial device
- ★ 8 switch selectable drivers for printers, terminals and modems
- ★ Includes Cable & Manual

\$99⁰⁰

TIMELINK REAL TIME CLOCK

- ★ Applications in file management, word processing, communications, etc.
- ★ Exclusive Alarm Clock feature
- ★ Battery recharges automatically

\$84⁰⁰

NEW BUFFERLINK ADD-ON PRINTER BUFFER

- ★ Saves Time — No more waiting for printed output
- ★ Connects easily to any parallel interface
- ★ Expandable from 16K to 64K

\$139⁰⁰ (16K)

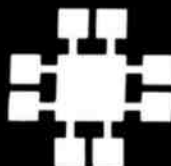

JDR Microdevices

1224 S. Bascom Ave. • San Jose, CA 95128
 (408) 995-5430 • Telex 171-110

1983 JDR MICRODEVICES, INC.

VISIT OUR RETAIL STORE

HOURS: M-W-F, 9-5 T-Th., 9-9 Sat. 11-3

PLEASE USE YOUR CUSTOMER NUMBER WHEN ORDERING
 TERMS: For shipping include \$2 for UPS Ground or \$3 for UPS Blue Label Air. Items over 5 pounds require additional shipping charges. Foreign orders, include sufficient amount for shipping. There is a \$10 minimum order. Bay Area and Los Angeles Counties add 6% Sales Tax. Other California residents add 8% Sales Tax. We reserve the right to substitute manufacturer. Not responsible for typographical errors. Prices are subject to change without notice. We will match or beat any competitor's price provided it is not below our cost.

Unclassified Ads

WANTED: Get a tax deduction instead of a cash loss when you sell your equipment. I can put you in touch with nonprofit organizations that need your donated equipment and can give you a tax receipt. Rev. Edw. Simpson, POB 931, Columbia, MD 21044. [301] 997-4992.

NEEDED: A network 2 controller, two printers, 16 nondisk student station/terminals, and modem to supplement a TRS-80 Model I. Group of educators plans to teach computer literacy in a low-income community. All contributions are tax deductible. Dr. Sidney Rabsatt, 1122 Banbury Cross, Arondale Estates, GA 30002. [404] 292-8366.

WANTED: A nonprofit agency that serves mentally retarded adults seeks tax-deductible donations of computers, modems, printers, and terminals. Certified receipts will be furnished. Winifred Law Opportunity Center Inc., 106 East Second, POB 434, Indianola, IA 50125. [515] 961-5341; call collect, ask for Alan or Ron.

WANTED: Nonprofit educational research organization seeks donation of tax-deductible personal computer (Apple) for record keeping. Greater Milwaukee Chapter of Ileitit and Colitis, 626 East Wisconsin Ave., Milwaukee, WI 53213. [414] 291-6980.

WANTED: Tax-exempt nonprofit whale-research organization needs functional hardware and/or software in data and word processing with 64K potential, and printing/accounting capabilities. Our references and IRS information available on request. Frederick Wenzel, Director of Operations, Mingan Island Cetacean Study Inc., POB 518, Meriden, CT 06450.

WANTED: Church seeks Apple II Plus equipment for use in Christian education program. All donations are tax deductible. Rev. Jay van Santen, First Presbyterian Church, 609 Southeast Second St., Evansville, IN 47713.

WANTED: Commodore 64- or VIC 20-compatible software to use in computer literacy/programming classes and tutorial studies in private Christian school. All donations are tax deductible. Rodney Cain, Faith Academy, 4700 South Main, Rockford, IL 61102. [815] 964-0133.

WANTED: A donation of a computer for use in bulk mail and records of nonprofit organization and OSI CBP DF with interface to Control B stepping motor animation stand. Also, information about fund raising by computer mailing list for Christians and Jews. Dan Coffin, Aim for Christ, 654 Kennebec Ave., Takoma Park, MD 20912.

FOR SALE: Lots of hardware/software: Apple, Commodore, Zenith. Also, disk packs, modems, chips, disks, cables, cable parts, ribbons, and so on. Much is brand new. Selling at auction. Send SASE for catalog. Will consider donating all or part to worthwhile IRS-approved charity. Edwin F. Schnaeffer, 3 Waters Edge Place, Lexington, KY 40502. [606] 266-9861.

FREE: Computer-language hobbyist gives free advice and technical information about the Algol-sixteen language (for the IBM PC, Zenith Z-100, TI-PC) and other programming languages: BASIC, PL/I, FORTRAN. Send SASE, D. Baer, POB 3020, Farmingdale, NY 11735. [516] 694-5872.

WANTED: Schematics, especially parts lists showing the IC numbers for the Redactor (Burroughs) Console. This is a two-cassette drive and connects to an IBM Selectric II printer (used as a word processor). Will reimburse. Dan Test, POB 90648, Newark, NJ 07104.

FOR SALE: Teletype 912C terminal: \$450. Two SA400 drives with cabinet: \$200. Two 19-inch color RGB monitors: \$150 each. Will consider any reasonable offers. Rich Pagnusat, 748 Berkley, Elmhurst, IL 60126. [312] 941-0739.

FOR SALE: Three former employees of Digital Group are selling their systems. Send SASE for a list of systems, boards, and parts. Sco Scofield, 1183 Lamar St., #B, Lakewood, CO 80214.

WANTED: Documentation for IMSAI VDP80, especially DIO disk controller or correspondence with anyone familiar with the above. Is there an IMSAI orphans club out there somewhere? May be interested in spare parts or ideas on how to update the VDP80. Grant Hargrave, 8265 ave. de Gaspé, Montreal, Quebec H2P 2J9, Canada.

FOR SALE: Tektronix 7D02 programmable logic/state analyzer, fully implemented with timing option for 48 channels. Includes 7603 mainframe, 7D02 plug-in, general purpose personality module, cabling, and test clips. New condition. Asking \$7000, but will negotiate. Michael Balamuth, 300 East Main St., Centerport, NY 11721. [516] 427-7224.

FOR SALE: Excellent condition North Star Horizon with 64K memory and two quad disk drives. Intertube II display. N* floating-point board, and Godbout Spectrum board. Software includes N* DOS, CP/M-2.2, FORTRAN, Statistical Program, and Games: \$2000 or best acceptable offer. Philip K. Hopke, 706 South Lynn St., Champaign, IL 61820. [217] 352-4282.

FOR SALE: Eight Microvision cartridges (Baseball, PhaserStrike, Alien Raiders, Sea Duel, Cosmic Hunter, Bowling, Connect Four, and Mind Buster). All in good condition. Originally \$18 each; will sell for \$100 or will trade for TRS-80 Color Computer software and/or hardware. Richard Wasserman, 2795 East 63 St., Brooklyn, NY 11234.

FOR SALE: LA36/LA35 DECwriter II—Interactive Data Communications terminal, standard ASCII keyboard, input/output device. Asking \$1000. John L. Chlada, East 210 Route 4, Paramus, NJ 07652. [201] 843-7700.

WANTED: Unwanted or broken printers, computers, and other peripherals. Also, any software for Apple II computer. I'll pay shipping and handling. Charles Dixon, 1450 Jersey Lane, Waterloo, IA 50701.

FOR SALE: IBM Asynchronous Communications adapter for the IBM PC. Supports a variety of RS-232C interfaces and is fully communication programmable. Data rate selectable 50 to 9600 bps. Complete documentation: \$100. IBM 64K memory-expansion board: \$220. IBM Parallel Printer Adapter, complete documentation: \$100. All boards less than a year old and in excellent condition. R. W. Loselsky, 36 Old Millford Lane, West Milford, NJ 07480.

WANTED: Amputated arm from HERO-1. Wade Nelson, 13303 R. Penasquitos Blvd. #A108, San Diego, CA 92129. [619] 692-7228 days and 484-1485 evenings and weekends.

FOR SALE: VIC-20, 16K RAM, super-expanded, introduction to BASIC, three games (Gorf, Quest, and Defender on Tril) three VIC books. All in super condition. Thomas Albertson Jr., 3612 Sprucedale Dr., Annandale, VA 22003. [703] 256-9260.

FOR SALE: Complete Netronics ELF II system with 28K RAM, Giant I/O board, Epson printer interface, ASCII keyboard, 44-pin bus adapter board, text display with high-resolution graphics, power supply, and enclosure. Software includes BASIC, text editor, monitor, and dozens of games. Complete documentation, extensive literature. Worth over \$1150. George Musser, 60 Broadway Rd., Warren, NJ 07060. [201] 647-1437.

FOR SALE: Commodore 4016 computer with 16K RAM, a built-in 12-inch green screen, and a full-sized keyboard. It contains a new version 4.0 BASIC and is only one year old. In good condition; asking \$680. Leon Fan, 4738 C. Main St., Skokie, IL 60076. [312] 679-4007.

FOR SALE: IMSAI PCS-44 64K RAM, 8085 processor, dual 5 1/4-inch format either 40 or 77 track (360+K each), IMDOS 2.05 with utilities, and manuals. \$1500. Jerry Augst, 5233 16th Ave. S, Minneapolis, MN 55417. [612] 726-2699 weekdays.

WANTED: People or clubs interested in joining nationwide hardware/software Computer Buying Club are welcome to join. Monthly newsletter, card catalogs, special services, and news-flash updates. M. Louis Britt, Suite 7502, 1400 Worcester Rd., Framingham, MA 01701.

FOR SALE: TRS-80 Model I 48K, MDX-2 interface, RS-232C, modem, printer port, two Tandon 40 track drives, NEWDOS, FORTRAN, and more. Good condition. \$1595. Wendell Hutchings, [303] 733-2439 between 8 and 5.

FOR SALE: Osborne I single-density drives: \$1350. TRS-80 Model II 64K with CP/M 2.2: \$2750. Model II Expansion Unit with one drive: \$750. TRS-80 Line Printer VI: \$750. Chelley Hoffman, Box 413, Gates Mills, OH 44040. [216] 729-2808.

FOR SALE: Used wire-wrap tools. Thor 115v industrial gun, uses standard 22- to 32-gauge bits: \$60, less bit. OK Hobby-Wrap gun with 30-gauge bit and Ni-cad batteries: \$20. 26- to 28-gauge bit for OK gun: \$5. Vector Sili-N-Wrap manual tool: \$17. spare bit: \$8. OK Just-Wrap manual tool: \$8. Edsyn Deluxe Soidapull, anti-static model: \$15. Bob Levine, 32 King St., New York, NY 10014. [212] 691-2897.

FOR TRADE: TRS-80 Model III-compatible software to swap: utilities, word processing, games. Send a list, disk or cassette of your better programs and I will promptly return same. I have two drives and can accept nonsystem disks. Cassettes limit two programs. Michael Vernier, POB 3075, Farmington Hills, MI 48018. [313] 661-1205.

FOR SALE: OSI 8K computer system, 6A switching power/supply, RS-232C port, Centronics serial printer, 9-inch GBC black-and-white monitor. All documentation included: \$400. Mark Woihe, 62 Coddington Ave., Hopelawn, NJ 08861. [201] 442-5242 evenings.

FOR SALE: NEC PC8001A complete system, 280 processor, 64K RAM, BASIC in ROM, RGB color monitor, printer, dual DSDD disks, CP/M, Supercalc, dBASE II, Modem7, SELECT, games, and more software. Great development system. Perfect shape, best offer. Richard Beal, POB 44, Aptos, CA 95003. [408] 688-8648.

FOR SALE: Four Shugart 8-inch SA1002 5.33-megabyte hard disk drives, unused: \$380 each. Also, Western Digital controller for this drive: \$350 each. Herb Merrill, 20 Randy Dr., Taylors, SC 29687. [803] 877-9444.

FOR SALE: Unused software for Commodore VIC-20s with at least 6K RAM. A few of these cassettes and cartridges have been slightly used but are in excellent condition. Send SASE. Ken Payne, 2623 Brocklin Dr., Grayson, GA 30221. [404] 972-3091 after 5 p.m.

FOR SALE: HP-85A microcomputer with built-in high-performance tape drive, printer, and monitor. 16K RAM module (32K total); 82950A direct connect/auto dial modem; HP-IB interface; and ROMs: Advanced Programming, I/O, mass storage, printer/plotter, and matrix. In software, three word-processing programs (\$550 retail), telecommunications, games, database program, 30 tapes (\$19 retail each), and padded carrying case with dust cover. Current value \$4600+; asking \$3300 or best offer. Bob Midden, [301] 338-3346.

FOR SALE: New parallel-printer interface by Micro World Electronix, Model MW-302, for the Commodore VIC-20 or 64. Use with all Centronics type printers and plotters. Switch-selectable options include 7- and 8-bit output, ASCII or PET ASCII, and device 4, 5, 6, or 7. Professional Software recommends MW-302 for use with 64 version of Word Pro 3+. List price \$119.95; will sell for \$80. W. R. Freytag, 1141 Kathryn St., Boalsburg, PA 16827.

WANTED: MPX-16 owner seeks correspondence with other owners or users. David Claxton, RFD Box 449, West Bath, ME 04530. [207] 443-4588.

WANTED: People interested in sharing ideas about Apple III. The possibility exists of forming an international users group. George H. Buch, c/o Buchan, Ravnsborggade 19, Copenhagen 2200 N, Denmark.

FOR SALE: Heath H-8 with 8K memory and H-9 video. Presently inoperable. Ideal for one with good electronics background or an electronics hobbyist. Will take best offer. Michael R. Skwark, 2517 Pineway Dr. S. Mobile, AL 36605. [205] 476-0464.

WANTED: Documentation for the Atari Video Computer System. Particularly interested in schematics and instructions to convert the game from NTSC to PAL-N systems. Will cover your shipping and printing costs. Fernando Ubrira, Uruguay 1198 Apt. 2, Montevideo, Uruguay, South America.

FOR SALE: Two Shugart SA-400 SDD disk drives in separate cabinets with power supplies and manual. Asking \$325. Will pay postage within U.S. S. Jackson, 2272 Covent Gardens Court, Reston, VA 22091. [703] 476-4763.

WANTED: College student/programmer seeking correspondence with owners of TRS-80 Color Computers and Monroe microcomputers to exchange programs and information. Also looking for used disk drives and modems. Lawrence Hall, 94-19 133 St., Richmond Hill, NY 11419.

FOR SALE: Hewlett-Packard 9845A desktop computer complete with 64K RAM (62K available for programs), 80-column monitor, fast thermal printer, two fast tape drives, graphics ROM and high-resolution graphics, modem, 32 user-programmable keys, various software, and other supplies. Mark Brandon, 2720 Fernbrook Lane, Minneapolis, MN 55441. [612] 559-9361 days.

FOR SALE: Hewlett-Packard HP-85 professional microcomputer with 32K main memory. Two software packs include Visicalc Plus and Financial Decisions. Less than one year old. Asking \$2200. Dean Nolte, 11625 Applewood Knolls Dr., Lakewood, CO 80215. [303] 233-7971.

FOR SALE: Teletype Model ASR-35 with 20-mA current-loop interface and complete manuals: \$250. Tim Martin, 1900 Noriega St., San Francisco, CA 94122. [415] 665-6656.

FOR SALE: DEC LA-34 DECwriter IV printer/terminal with 7 by 9 dot-matrix printer with full remote-terminal capabilities; expanded and compressed print 7 choices of vertical pitch; 7 foreign-language character sets; built-in diagnostics. All features are software or keyboard selectable. Has full 67-key typewriter keyboard. Accepts any paper size up to 14 inches; friction or tractor feed; used only 2 months in light, noncommercial environment: \$1000. Steve Otent, 13 Park St., Hudson, MA 01749. [617] 562-7150.

WANTED: Contact with users of Morrow Designs' Micro Decision in Los Angeles area. Let's get together for sharing ideas and mutual help. Send SASE and I'll coordinate arrangements. E. R. Paquin, 104 West Wistaria, Arcadia, CA 91006. [213] 447-6541.

UNCLASSIFIED POLICY: Readers who have computer equipment to buy, sell, or trade or who are requesting or giving advice may send a notice to BYTE for inclusion in the Unclassified Ads section. To be considered for publication, an advertisement must be noncommercial (individuals or bona fide computer clubs only), typed double-spaced on plain white paper, contain 75 words or fewer, and include complete name and address. This service is free of charge; notices are printed once only as space permits. Your confirmation of placement is appearance in an issue of BYTE as we engage in no correspondence. Please allow at least three months for your ad to appear. Send your notices to Unclassified Ads, BYTE/McGraw-Hill, POB 372, Hancock, NH 03449.

Unclassified Ads

FOR SALE: Model KSR-35 Teletype with 20-mA loop, complete manuals set, cable, and connector: \$200. IMSAI video board with graphics and terminal firmware (full house): \$100. IMSAI SIO board: \$75. North Star disk-controller board: \$85. Three Tarbell cassette boards: \$25 each or \$60 for all. All S-100 boards with manuals, some never used. S. Hall, 2259 College St., #1, Jacksonville, FL 32204. (904) 389-9583.

FOR TRADE: I have 100 disks of Atari software available for trade. Send a list of your software and a telephone number. Include a SASE for a copy of my list. Ken Mizoi, POB 31, Orangeburg, NY 10962. (914) 352-8768.

WANTED: Users of TRS-80 Models I and III or Sinclair ZX81/TS1000 willing to exchange information or programs. Case Larsen, 115 Bixby Dr., Milpitas, CA 95035.

FOR SALE: OT vertical cabinet and power supply for single 8-inch disk drive. Lists for \$300, like new: \$150. Mike Schmidt, 1140 Castro #18, Mountain View, CA 94040. (415) 968-8661.

FOR SALE: Teletype 912C terminal in excellent condition. Features 24 by 80 display, full attribute set, two pages of memory, numeric pad, cursor movement keys, and much more. Printer port only requires connector if desired. First \$500 owns new terminal. George Sipe, 4873 Scotts Mill Way, Duluth, GA 30136. (404) 447-4731 weekends.

FOR SALE: TI-99/4A home computer, 16K, video modulator, cassette cable, and the following cartridges: Amazing and Adventure including Pirate: \$150 takes it all. Matthew Reilly, 46 Spring Hill Ave., Norwalk, CT 06850. (203) 847-4945.

FOR SALE: SSM VB18 video board with 64 by 16 display. SSM 8K static RAM board. New Godbout Interfacer 2 I/O board with three parallel and one serial ports and Interrupt timer. Also, Centronics 761 ASCII keyboard: \$310 or best offer. All are S-100/IEEE 696 compatible in good working order. Will sell items separately. Michael Cohen, 206 Overlook Rd., Ithaca, NY 14850. (607) 257-0342 evenings.

FOR SALE: IBM Model 1980 I/O typewriter, good operating condition, complete with Model 1971 buffered terminal electronics and power supplies, and all available schematics. Can be interfaced for use as letter-quality printer: \$250. Also, TRS-80 Model I 64K system with Level II BASIC. Includes expansion interface, keyboard with numeric keypad, monitor with built-in audio circuits, power supplies, tape recorder, manuals, games, and utilities: \$650 or best offer. Jack Bozzuffi, 328 Bucknell Ave., Turnersville, NJ 08012. (609) 228-3385.

FOR SALE: SwTPC 68/A computer 40K RAM with serial and parallel I/O, three disk drives, and Percom Graphics board with extras including software: \$1000 or best offer. D. Melbarde, 105 Christopher St., Hackettstown, NJ 07840. (201) 852-9389.

FOR SALE: SwTPC 6800 with 28K RAM, 4K EPROM programmer/card, one serial and three parallel I/O cards, dual 5 1/4-inch floppy disks, ADM-3A terminal, Novation modem, and software: \$1000. Ken Staton, POB 10490, Stanford, CA 94305. (415) 856-8147.

FOR SALE: Apple III programs for sale or trade. Send for list. E. Foreman, Box F, Mobile, AL 36601.

FOR SALE: Digital Group Z-80 system with 26K memory, two Phidecks, I/O board, keyboard, monitor. MaxiBASIC, all Digital Group games, and dress-tan cabinet. Interfaced to Sanders 3110 printer. Everything is fully operational, complete documentation included. Complete system with printer: \$750. Steve Izard, 1890 Shady Lane, Columbia, SC 29206. (803) 787-8523.

WANTED: Someone to make a printed-circuit board for a microcomputer. Mike Graff, 1716 Davis Ave., Grinnell, IA 50112.

FOR SALE: Ohio Scientific C1P with 8K RAM, Microsoft BASIC plus 6502 monitor in ROM. Includes all cables and manuals for cassette operation. A dozen programs included: \$300. Video monitor available: \$85. David Ellis II, 101 Shady Lane, Wabash, IN 46992.

WANTED: Assembly-language program for IBM PC special-character substitution on monochrome display adapter to enable substitution of IBM PC high ASCII characters (128 to 255) for normal characters only on display, not in programs, files, or to printer. If special characters are sent to some programs (e.g., Wordstar) they are taken as control characters. Believe Interrupt-decimal 16 and service codes decimal 10 and 14 are key. Alan Fiske, 5107 South Blackstone Apt. 505, Chicago, IL 60615.

FOR TRADE: Send a list of Apple software (utilities, games, word processing, etc.) and I will send you mine. Send SASE. Jim Myhre, 17 South Dr., East Brunswick, NJ 08816.

BOMB BYTE's Ongoing Monitor Box

Article #	Page	Article	Author(s)
1	36	The HP 150	Lemmons, Robertson
2	51	An Interview: The HP 150's Design-team Leaders	Lemmons, Robertson
3	67	Build the Micro D-Cam Solid-State Video Camera, Part 2: Computer Interfaces and Control Software	Ciarcia
4	94	BYTE West Coast: Shaping Consumer Software	Lemmons, Robertson
5	107	User's Column: New Computers, Boards, Languages, and Other Tidbits	Pournelle
6	132	The Unix Tutorial, Part 3: Unix in the Microcomputer Marketplace	Fiedler
7	160	Unix and the Standardization of Small Computer Systems	Yates
8	170	A Tour Through the Unix File System	Joyce
9	187	The Unix Shell	Bourne
10	209	Unix as an Application Environment	Krieger, Pack
11	219	Usenet: A Bulletin Board for Unix Users	Emerson
12	241	The Unix Writer's Workbench Software	Cherry, Macdonald
13	253	Typesetting on the Unix System	Tuthill
14	266	Moving Unix to New Machines	Tilson
15	280	The NEC Advanced Personal Computer	Suits
16	292	Radio Shack's TRS-80 Model 4	Archer
17	306	The Morrow Micro Decision	Wadlow
18	316	The Microneye	Wieland
19	324	The M68000 Educational Computer Board	Floyd
20	341	Fancy Font	Hoffman
21	350	Photographic Animation of Microcomputer Graphics	Cann
22	366	The Fourth National Computer Graphics Association Conference	Pournelle, A.
23	384	Echonet, Part 2: The Compiler	Barber
24	398	Computer Crime: A Growing Threat	Gillard, Smith
25	428	More Unix-style Software Tools for CP/M	Kern
26	439	Mainframe Graphics on a Microcomputer	Kelly
27	447	Talker	Williams
28	480	Bitmaps Speed Data-handling Tasks	Sohr
29	499	Simplified Program Interfacing	Irvine

Real-Time Builders Vote for Ciarcia

The July BOMB tally reveals Steve Ciarcia to be first in the winner's circle with his article, "Build the RTC-4 Real-Time Controller." The author of the Circuit Cellar takes the \$100 prize. Second place in the winner's circle is Jerry Pournelle's User's Column entitled "Interstellar Drives, Osborne Accessories, DEDICATE/32, and Death Valley." The doctor will be awarded \$50. And Mark Dahmke's article, "CP/M Plus," takes third place in our monthly countdown.

Correspondence

Address all editorial correspondence to the editor at BYTE, POB 372, Hancock, NH 03449. Unacceptable manuscripts will be returned if accompanied by sufficient first-class postage. Not responsible for lost manuscripts or photos. Opinions expressed by the authors are not necessarily those of BYTE. Entire contents copyright © 1983 by BYTE Publications Inc. All rights reserved. Where necessary, permission is granted by the copyright owner for libraries and others registered with the Copyright Clearance Center (CCC) to photocopy any article herein for the flat fee of \$1.50 per copy of the article or any part thereof. Correspondence and payment should be sent directly to the CCC, 21 Congress St., Salem, MA 01970. Specify ISSN 0360-5280/83. \$1.50. Copying done for other than personal or internal reference use without the permission of McGraw-Hill is prohibited. Requests for special permission or bulk orders should be addressed to the publisher, BYTE® is available in microform from University Microfilms International, 300 North Zeeb Rd., Dept. PR, Ann Arbor, MI 48106 USA or 18 Bedford Row, Dept. PR, London WC1R 4EJ England.

Reader Service

Inquiry No.	Page No.	Inquiry No.	Page No.	Inquiry No.	Page No.	Inquiry No.	Page No.
1	1ST NATIONAL COMPUTER 285	83	CHRISLIN IND. INC. 101	164	DYSAN CORP. 327	237	INTERDATA SYSTEMS INC. 616
2	1 SUPER WAREHOUSE 225	541	CIRCUITS & SYSTEMS 88	165	EAGLE SOFTWARE 412	550	INTERFACE INC. 312
4	3R COMPUTERS 527	84	CLEO 525	166	EAST SIDE SOFTWARE 413	551	INTERFACE INC. 312
5	800 SOFTWARE 99	85	CMC,INT'L. 182	167	EASTERN ENTERPRISES 300	*	INTERSTATE ELECTRONICS 320 WC1
6	A.S.T. RESEARCH 137	86	COGITATE 624	168	EASTMAN KODAK CO. 501	238	INTERTEC DATA SYS. 10, 11
8	AB COMPUTERS 615	87	COLORADO COMP.PERIPH. 620	169	ECOSOFT 550	239	ISE/MICRO DATA BASE 551
9	ABC DATA PRODUCTS 456	88	COLUMBIA DATA PROD. 184, 185	170	EDUCATIONAL MICROCOMP. 584	240	J.C.SYSTEMS 26
11	ACCESS UNLIMITED 618	89	COMMAND SERVICES CORP. 616	171	EDUCATIONAL MICROCOMP. 418	241	JADE COMP.PROD. 644, 645
12	ACL INC. 176	90	COMMUNICAL, INC. 572	533	ELECTRONIC PROTECTION DEVICES 155	242	JADE COMP.PROD. 646, 647
13	ACORN COMP.CORP. 158, 159	94	COMPAQ COMPUTER CORP. 13	172	ELECTRONIC SPLISTS 580	243	JADE COMP.PROD. 648, 649
14	ACTIVE ELECTRONICS 424	95	COMPONENTS EXPRESS 410	173	ELECTROSONICS 612	244	JAMECO ELECTR. 654, 655
15	ADDMASTER CORP. 418	96	COMPUADD 616	174	ELLIS COMPUTING INC. 213	245	JAMES FOX ASSOC. 612
16	ADV.COMP.PROD. 619	97	COMPUADD 616	175	ELLIS COMPUTING INC. 430	245	JAMES LW & ASSOC. 416
*	ADV.DIGITAL CORP. 77	98	COMPUCLASS 632	176	EMERY AIR FREIGHT 498	246	JANUS 32A
17	ADV. DIGITAL INFORMATION 614	99	COMPUPRO 33	177	EMPIRICAL RESRCH.GRP. 86	247	JDR MICRODEVICES 663
18	ADV.LOGIC SYSTEMS 467	525	COMPUPRO 576, 577, 578	178	ENGINEERING SPECIALTIES 634	248	JDR MICRODEVICES 666, 667
19	ADV.PROCESSOR SYS. 622	101	COMPUSERVE 71	179	EPSON AMERICA 521	249	JDR MICRODEVICES 668
20	ADV.SYS.CONCEPTS 570	102	COMPUSHACK 561	539	EROS 143	544	JE COMPUTER 92
21	AFTERTHOUGHT ENG. 612	103	COMPUSOFT PUBL.-B 628	180	ESPRIT SYS. INC. 286	250	JUKI INDUSTRY OF AM 386
23	AGRIPLEX COMPUTERS 418	104	COMPUTER ACCESSORIES 328	181	EXCEL 120	251	JVB ELECTRONICS 628
23	ALBERT COMPUTERS 264, 265	91	COMPUTER APPARATUS 117	182	EXECUTIVE SOFTWARE 66	252	K&R COMPUTER CO.LTD. 632
24	ALCOR SYSTEMS 263	105	COMPUTER CHANNEL 483	183	EXPOTEK 334	253	KADAK PRODUCTS 102
25	ALF PRODUCTS, INC. 552	107	COMPUTER COMPONENTS UNLTD. 652, 653	184	EXTENDED PROCESSING 624	254	KADAK PRODUCTS 410
26	ALL ELECTRONICS CORP. 624	108	COMPUTER CONNECTION 628	185	EXXON OFFICE SYSTEMS 488	540	KAYPRO 554, 555
27	ALPHA BYTE COMP.PROD. 180	109	COMPUTER DISCOUNT PROD. 621	186	FACIT INC. 355	255	KELLY COMP.SUPPLIES 632
28	ALPHA BYTE COMP.PROD. 396, 397	108	COMPUTER ENTREPRENEUR 529	187	FALCON SAFETY PROD. 274	256	KELLY COMP.SUPPLIES 634
29	ALPHA OMEGA COMPUTER 204	103	COMPUTER EXCHANGE 238, 239	542	FIDELITY DEV. CORP. 88	257	KENSINGTON MICROWARE 332
30	ALTOS COMP.SYS. 73	532	COMPUTER EXCHANGE 238, 239	185	FIGURE LOGIC BUS.EQUIP. 612	258	KENSINGTON MICROWARE 375
31	AM 84 CONFERENCE & EXHIBITION 360	559	COMPUTER EXCHANGE 238, 239	186	FLIP-IT 260	259	KERN PUBLICATIONS 202, 203
*	AMDAHL 320 WCI	109	COMPUTER FOOD PRESS 662	187	FORMULA INT'L. 613	261	KEY TRONIC CORP. 465
32	AMDEK CORP. 21	109	COMPUTER HUT OF NE 485	188	FORMULA INT'L. 613	262	KING SOFTWARE 662
34	AMER. BUYING & EXPORT 424	110	COMPUTER INNOVATIONS 148	189	FORMULA INT'L. 613	263	LABORATORY MICROSYS. 612
33	AMER.SQUARE COMP. 235	111	COMPUTER MAIL ORDER 496, 497	190	FOX & GELLER INC. 135	264	LAREM INC. 414
35	ANADIX 115	112	COMPUTER OUTLET 623	191	FRANKLIN COMP.CORP. 377	265	LARK SOFTWARE 618
36	ANGELS COMPUTER 507	*	COMPUTER PLUS 79	191	FUJITSU PROFESS.MICROSYS. 335	555	LAWSON LABS 662
536	ANKO ELECTRONIC 90	113	COMPUTER POST INC. 627	537	G.G.M. INDUSTRIAL 90	266	LEADING EDGE PROD. CIII
37	ANTEX DATA SYS. 124	114	COMPUTER SOFTWARE ASSOC. 620	193	G&G ENGIN. 393	267	LEHMANN & ASSOC. 470
38	APPARAT INC. 461	115	COMPUTER STORE, THE 622	558	GARDEN OF EDEN 662	268	LEXICOMP DATA SYS. 630
39	APPLE COMPUTER INC. CII, 1	116	COMPUTER STORE, THE 624	192	GENERAL MICRO SYSTEMS 632	269	LIBERTY GROUP INC. 493
41	APPLE COUNTRY LTD. 617	117	COMPUTER WAREHOUSE 259	193	GIFFORD COMP. SYS. 393	282	LIGO RESEARCH 357
42	APPLEWARE, INC. 488	117	COMPUTERLINE INT'L-A 404, 405	194	GILTRONIX INC. 418	270	LINK 320 SE3
43	APPLIED LOGIC INC. 634	118	COMPUTERLINE INT'L-B 346	195	GLOBAL EQUIPMENT INC. 614	271	LINTEK INC. 568
546	APPLIED SOFTW.TECH. 229	119	COMPUTER-MATE INC. 218	196	GLOUCESTER COMP.CO.INC. 612	272	LOCKHEED DIALOG 505
44	ARBA 470	120	COMPUTERS AND MORE 400	557	GOODWILL ELECTR. 662	272	LOGICAL DEVICES 20
45	ARTIFICIAL INT'L.RESRCH. 616	121	COMPUTERS AND MORE 614	198	GREAT SALT LAKE COMP. 642, 643	273	LOGICAL MICROCOMPUTER 298
46	ASHTON-TATE 127	565	COMPUTERS WHOLESALE 208	*	GTCO CORP. 301	274	LOMAS DATA PRODUCTS 547
47	ASHTON-TATE 256	530	CONROY-LAPOINTE 238, 239	199	GTEK INC. 190	275	LOTUS DEVELOPMENT 249
*	AUTOCODE 199	531	CONROY-LAPOINTE 238, 239	*	GULFSTREAM 320 WC2	276	LSI JAPAN CO. 614
48	AUTOCONTROL INC. 628	532	CONROY-LAPOINTE 238, 239	*	GULL 320 NE4	535	LUNG HWA ELECTRONICS 90
49	AUTOCONTROL INC. 630	123	CONSOLINK 166	*	H&E COMPUTRONICS 31	277	LYBEN COMP.SYS. 622
50	AVERY LABEL 356	*	CONTROL DATA CORP. 157, 257	201	H&M DISK DRIVE SERVICES 630	278	LYBEN COMP.SYS. 624
51	AVERY LABEL 356	125	CONTROL ELECTRONICS INC. 302	202	HANDWELL CORP. 631	279	LYBEN COMP.SYS. 626
52	AVIS RENT-A-CAR 571	538	CORONA DATA SYS. 304, 305	203	HAYDEN SOFTWARE 233	280	LYCO COMPUTER 109
53	AVOCET 347	126	COST PLUS COMP. 634	204	HAYDEN SOFTWARE 446	281	MAGTECH INT'L. 477
*	AXEL JOHNSON 199	556	CREATIVITY UNLTD. 662	205	HAYES MICROCOMP.PROD. 83	283	MAGIC COMPUTER CO. 309
*	AYEWIPS 618	127	CROMEMCO 5	207	HAYES MICROCOMP.PROD. 164, 165	285	MANNESMANN TALLY 407
54	BAHR TECHNOLOGY 144	128	CSCS 630	208	HAYES MICROCOMP.PROD. 459	286	MANX SOFTWARE 136
55	BALCONES COMP.CORP. 125	129	CUESTA SYSTEMS 622	*	HAYES MICROCOMP.PROD. 320 SE1	287	MARYTAN SOFTWARE ASSOC. 624
56	BASIS, INC./COMP.SYS. DESIGN 401	130	CUSTOM COMP.TECH. 633	209	HEATH COMPANY 228	288	MARYMAC INDUSTRIES 632
58	BAY TECHNICAL ASSOC. 30	131	CYBERTEK CORP. 488	210	HEWLETT-PACKARD 216, 217	*	MC-P APPLICATIONS 422
59	BELL, JOHN ENGR. 638	132	D.C. CRANE INC. 620	*	HEXADAISY PRODUCTS 620	289	MEGABYTE INDUSTRIES 612
60	BELL, JOHN ENGR. 638	134	DATA DISTRIBUTING ENT. 620	211	HOLIDAY INN 321	290	MET CHEM INT'L.CORP. 289
61	BELL, JOHN ENGR. 638	135	DATA ELECTRONICS INC. 240	212	HOLLYWOOD HARDWARE 138	291	METASOFT CORP. 471
62	BELL, JOHN ENGR. 638	137	DATA-MAIL 562	517	HOUSTON INSTR.DIV. OF BAUSCH & LOMB 379	293	MICRO AGE COMP.STORES INC. 237
560	BG COMPUTER APPL. 662	138	DATA-RITE CORP. 488	213	HUMAN DESIGNED SYSTEMS 463	301	MICRO CRAFT 34, 35
63	BHRT 348, 349	139	DATABASE RESEARCH 295	214	HUMAN SOFT 211	294	MICRO DATA SUPPLIES 326
64	BLUE CHIP SOFTWARE 403	140	DATAMASTER 612	215	I/O TECHNOLOGY 231	295	MICRO MANAGEMENT SYS. 533
65	BMC USA, INC. 567	141	DATASOUTH COMP CORP 364, 365	216	IBM CORP. 104, 105	296	MICRO MART 388
66	BMC USA, INC. 567	142	DATASOUTH COMP CORP 406	217	IBM SYSTEMS SUPPLY DIV. 515	297	MICRO MART 630
67	BMC USA, INC. 567	143	DECISION RESOURCES 112, 113	218	IBS COMPUTERTECHNIK 558	298	MICRO MINT 573
68	BMC USA, INC. 353	145	DECOTEC 630	219	IDEA WARE 283	299	MICRO WEST 553
69	BOTTOM LINE, THE 261	146	DENNISON KYBE CORP. 311	220	IMAGE COMP.PROD. 634	419	MICRO WORKS, THE 441
70	BRYLAR 614	147	DIAMOND SFTW. SUPPLY 110	221	IMS INTERNATIONAL 106	302	MICRODYNAMICS 632
*	BYTE BOOK CLUB/MCGRAW-HILL 545	148	DIGISOFT COMPUTER 400	222	INCOMM 432	303	MICROHOUSE 97
*	BYTE PUBL. INC. 466	149	DIGITAL DELI 616	223	INCOMM 582	304	MICROMAIL 610
*	BYTE BACK ISSUES 468	534	DIGITAL DIMENSIONS 476	225	INDEPENDENT BUS.SYS.INC. 275	305	MICROMATION 484
71	BYTEK COMP.SYS.CORP. 585	150	DIGITAL ELECT.SYS. 12	226	INDUS-TOOL 614	306	MICROMAX SYS. 103
70	BYTEWRITER 122	151	DIGITAL LABORATORIES 256	197	INDUSTRIAL 618	306	MICROMAX SYS. 103
72	C-SYSTEMS 232	152	DIGITAL MEDIA 626	228	INFOCOM INC. 290, 291	562	MICROPERIPH.CORP.THE 388
73	C-WARE CORP. 570	153	DIGITAL PRESS 408	229	INFOPRO SYS. 622	307	MICROPROCESSORS UNLTD. 620
74	C.S.D.INC. 434	154	DIGITAL RESEARCH COMP. 629	229	INFORUNNER CORP. 523	*	MICROSOFT (CPD) 151
514	CABLES UNLTD. 620	155	DIGITIME 626	230	INNOVA COMPUTER 92	308	MICROSOFT (CPD) 475
75	CADO SYSTEMS 215	156	DIRECT SOFTWARE 390	231	INSTITUTE-SCTF.ANALYSIS 227	308	MICROTECH 167
76	CALIF. DATA CORP. 488	157	DISCOUNT SOFTWARE 269	545	INT'L AEROSPACE 414	309	MICROTECH EXPORTS 214
*	CALIF. DIGITAL 635, 636, 637	158	DISK WORLD 289	554	INT'L COMP. & TELECOM.INC. 662	310	MICROTYPE 403
*	CALIF.MICRO.COMP. 416	159	DISPLAYED VIDEO 625	232	INT'L MICRO SYS. 173	311	MICROWARE 196
77	CANON USA 489	159	DMA SYSTEMS 559	233	INT'L TECH. SEMINARS 622	300	MICROXPRESS 458
78	CDEX 153	160	DOKAY COMP.PROD.INC. 650, 651	234	INTERGRAND 581	312	MILLER, J.W. 624
79	CDR SYSTEMS 612	161	DOW JONES SOFTWARE 433	235	INTERACTIVE STRUCT. 175	313	MINISCRIBE 320 SW2
80	CERTIFIED COMPUTERS, INC. 634	162	DUPONT COMPANY 421			314	MINTOLA CORP. 510, 511
81	CHECK-MATE 565	163	DWIGHT CO. INC. 630			315	MITRE CORP. 320 NE3
82	CHIPS & DALE 626	162	DYNACOMP 626				MITSUBA 178
		163	DYNAX INC. 299				MONUMENT COMPUTER SERV. 474

To get further information on the products advertised in BYTE, fill out the reader service card with your name and address. Then circle the appropriate numbers for the advertisers you select from the list. Add a 20-cent stamp to the card, then drop it in the mail. Not only do you gain information, but our advertisers are encouraged to use the marketplace provided by BYTE. This helps us bring you a bigger BYTE. The index is provided as an additional service by the publisher, who assumes no liability for errors or omissions. *Correspond directly with company.

Reader Service

Inquiry No.	Page No.	Inquiry No.	Page No.	Inquiry No.	Page No.	Inquiry No.	Page No.
* NAVAL AIR DEV.CTR. 320 NE8		527 PROGRAMMING INT'L. 435		427 SLR SYSTEMS 624		473 TINNEY, ROBERT GRAPHICS 575	
* NAVAL UNDERWATER SYS. 320 NE2		528 PROGRAMMING INT'L. 436, 437		428 SLR SYSTEMS 418		474 TITAN TECHNOLOGY 455	
325 NEC HOME ELECTR.USA 444, 445		529 PROGRAMMING INT'L. 438		429 SLUDER/COMPETITIVE EDGE 484		475 TOPAZ INC. 303	
383 NEC HOME ELECTR.USA 183		380 PROMETHEUS PRODUCTS 495		547 SOFTLINE 425		476 TOSHIBA AMERICA INC. 442	
* NETWORK CONSULTING INC. 139		382 PURCHASING AGENT, THE 302		430 SOFTRENT 620		477 TOSHIBA AMERICA INC. 443	
* NETWORK CONSULTING INC. 563		384 QUADRAM CORP. 15		432 SOFTWARE ARTS 128, 129		478 TRAK CO., THE 255	
327 NETWORK INC. 245		385 QUADRAM CORP. 75		433 SOFTWARE BANC 206, 207		479 TRANSACTION STORAGE SYS. 121	
328 NEWTECH CO. LTD. 558		386 QUADRAM CORP. 363		435 SOFTWARE DEV.CORP. 146		480 TRANSTAR 145	
329 NORTH STAR COMPUTERS 373		387 QUANT SYSTEMS 630		436 SOFTWARE DIGEST 426, 427		481 TRANSTAR 539	
330 NORTHWEST DIGITAL SYS. 150		388 QUARK ENGINEERING 314, 315		* SOFTWARE GUILD 278, 279		482 TRISTAR DATA SYS. 212	
331 NOVATION, INC. 123		389 QUBIE DISTRIBUTING 81		* SOFTWARE OF THE MONTH CLUB 100		483 TSK ELECTR.CORP. 345	
* NRI SCHOOLS ELECTR.DIV. 513		564 QUBIE DISTRIBUTING 189		437 SOFTWARE SERVICES 289		484 TSL 262	
332 O'HANLON COMP.SYS. 517		390 QUELO 562		438 SOLUTIONWARE CORP. 626		488 U.S. MICRO SALES 640, 641	
333 OFFICE NETWORKS CORP. 628		* QUEUE LIMITED 620		* SONICRAFT 320 NE7		485 U.S. ROBOTICS 18	
334 OLYMPIA U.S.A. INC. 277		391 R.C. ELECTRONICS 473		439 SPECTRON INSTRUMENT 616		489 UNIFIED SOFTWARE SYS. 470	
335 OLYMPIC SALES 557		392 R.C.ELECTRONICS 473		* SPERRY 320 SE4, SW1		490 UNIPRESS 387	
336 OMNI RESOURCES 543		393 R.R.SOFTWARE 111		440 SPRINGER-VELAG 276		491 UNIVERSAL COMP.PROD. 614	
338 ORYX SYSTEMS 478, 479		394 RADIO SHACK CIV		441 SPSS 550		492 UNIVERSAL DATA SYS. 27	
339 OSBORNE/MCGRAW-HILL 503		395 RANA SYSTEMS 22, 23		553 STAR LOGIC 560		493 VANTEC 628	
526 OVERLORD MONITORS 618		396 RANDOM ACCESS INC. 628		442 STAR MICRONICS 141		494 VAULT COMPANY 154	
340 OXFORD INT'L. INC. 546		397 RANDOM HOUSE 474		443 STARBUCK DATA CO. 454		495 VECTOR ELECTR. CO. 329	
* PACIFIC COMPUTERS 188		398 RCP ELECTRONICS 470		* STEMMOS LTD. 199		496 VICTORY COMP.SYS. 382, 383	
341 PACIFIC EXCHANGES 418, 614, 622, 626, 628, 630, 632, 634		399 RCA 340		444 SUNNY INT'L. 611		497 VIDEX 19	
349 PAN AMERICAN ELEC.INC. 582		400 REDDING GROUP INC. 149		445 SUNTRONICS 611		498 VISUAL TECH, INC. 449	
350 PANASONIC INDUSTRIAL DIV. 191		401 REVIEW PUBLICATIONS 142		543 SUPERCOM 88		499 VLM COMPUTER ELEC. 634	
552 PC TECHNOLOGY 564		402 RING KING VISIBLES INC. 156		10 SUPERLETTER/ABRAMS CREATIVE SERV. 618		500 VOTRAX 549	
351 PC WARE 32		* ROCKY MT.MICRO INC. 331		446 SUPERSOFT 193		501 VR DATA 531	
352 PC WARE 273		403 ROGERS ELECTRONICS 632		447 SUPERSOFT 195		502 W.T.I. COMP.&PERIPH.PROD. 369	
353 PEACHTREE SOFTWARE 28, 29		404 ROGERS LABS 622		448 SUPERSOFT 197		503 WADSWORTH ELECTRONIC PUBL 509	
355 PENCEPT INC. 343		405 RTL PROGRAMMING AIDS 470		449 SUPERSOFT 322, 323,		504 WANG ELECTR.PUBL. INC. 224.	
356 PER SCI INC. 622		406 S C DIGITAL 460		451 SWEET GUM INC. 108		* WANG LABS INC. 541	
357 PERCOM DATA 9		407 S-100 DIV. 696 CORP. 222		452 SWI INT'L. 569		* WAREHOUSE SOFTWARE 152	
* PERFECT SOFTWARE 59		408 SAFEWARE 537		453 SYBEX 147		506 WASHINGTON COMP.SERV. 402	
359 PERFECT SOFTWARE 60, 61		409 SAGE COMP.TECH. 87		454 SYNEXIT 223		507 WASHINGTON COMP.SERV. 564	
360 PERFECT SOFTWARE 62, 63		410 SAKATA 451		455 TALLGRASS TECH. 69		508 WESPER MICROSYSTEMS 201	
361 PERFECT SOFTWARE 64, 65		411 SCALAR ELECTRONIX (1982) INC. 632		458 TATUM LABS 616		509 WESPER MICROSYSTEMS 201	
375 PERSONALIZED COMPUTER PAPER 626		412 SCM ALLIED PAPER 85		459 TAURUS COMP.PROD.INC. 194		* WESTICO INC. 411	
363 PETRO-LEWIS FUNDS INC. 412		413 SCM CORP. 252		460 TAYCO BUSINESS FORMS 488		510 WHITESMITHS LTD. 462	
365 PHACT ASSOC. LTD. 568		* SCOTSDALE SYSTEMS 389		472 TDI 356		511 WILLIAMS, MARK CO. 535	
366 PHASER 119		414 SCREENWARE 626		461 TDK ELECTRONICS 415		512 WINTEK CORP. 624	
367 PHONE I, INC. 417		415 SEEQUA COMP.CORP. 6		* TECHNICAL SYS.CONSLTNS. 205		513 WORLDWIDE COMP.SUPPLIES 470	
368 PICKLES & TROUT 230		416 SEMI DISK SYSTEM 196		* TEKTRONIX INC. 319		515 WYSE TECHNOLOGY 409	
369 PMI ASSOCIATES 614		417 SENTINEL COMP. PRODUCTS 24		463 TELECON SYSTEMS 336		516 X COMP 453	
370 POOR PERSON SOFTWARE 628		418 SEXTANT MAGAZINE 333		464 TELETEK ENTERPRISES 25		517 XEROX EDUCATION PUBL. 457	
371 PRACTICAL PERIPH. 247		420 SGL HOMALITE 234		465 TELETEX COMMUNICATIONS 469		518 XIDEX MAGNETICS 250, 251	
372 PRINCETON GRAPHIC SYS. 179		362 SHARP ELECTRONICS 419		466 TERMINALS TERRIFIC 579		136 XL SYSTEMS 618	
373 PRINTER STORE, THE 519		421 SHARP ELECTRONICS 490		467 TEXAS COMP.SYS. 221		520 YIELD HOUSE 116	
374 PRIORITY ONE 656, 657, 658, 659, 660, 661		* SIEMENS COMM.SYS.INC. 168, 169		* TEXAS INSTRUMENTS 338, 339		521 ZOBEX 487	
376 PROF. SOFTWARE PROD. 181		423 SIERRA DATA SCIENCES 57		469 THOUGHTWARE INC. 423			
377 PROGRAMMERS SFTW. EX. 232		424 SIGNUM SYSTEMS 618		548 THREE M COMPANY 271			
		* SILICON SPECIALTIES 450		3 THREE M TRENDCOM. 359			
		* SIMPLIWAY PROD. 618		470 THUNDERWARE CORP. 634			

*Correspond directly with company.

BYTE ADVERTISING SALES STAFF:

J. Peter Huestis, Advertising Sales Manager, 70 Main Street, Peterborough, N.H. 03458 Tel (603) 924-9281

NEW ENGLAND

ME, NH, VT, MA, RI
Paul McPherson, Jr. (617) 262-1160
McGraw-Hill Publications
607 Boylston Street
Boston, MA 02116

ATLANTIC

NJ (NORTH), NY, NYC, CT
Eugene Duncan (212) 997-2096
McGraw-Hill Publications
1221 Ave of the Americas - 39th Floor
New York, NY 10020

Dick McGurk (212) 997-3588

McGraw-Hill Publications
1221 Ave of the Americas - 39th Floor
New York, NY 10020

EAST

PA (EAST), NJ (SOUTH), MD, VA, W. VA, DE, D.C.
Daniel Ferro (215) 496-3833
McGraw-Hill Publications
Three Parkway
Philadelphia, PA 19102

SOUTHEAST

NC, SC, GA, FL, AL, TN,
Maggie McClelland (404) 252-0626
McGraw-Hill Publications
4170 Ashford Dunwoody Road - Suite 420
Atlanta, GA 30319

MIDWEST

IL, MO, KS, IA, ND, SD, MN, WI, NB
Jack Anderson (312) 751-3740
McGraw-Hill Publications
Blair Building
645 N. Michigan Ave
Chicago, IL 60611

GREAT LAKES, OHIO REGION

MI, OH, PA (ALLEGHENY), KY, IN,
EASTERN CANADA
Dennis Riley (313) 352-9760
McGraw-Hill Publications
4000 Town Center - Suite 770
Southfield, MI 48075

SOUTHWEST, ROCKY MOUNTAIN

UT, CO, WY, OK, TX, AR, MS, LA
Alan Morris (214) 458-2400
McGraw-Hill Publications
Prestonwood Tower - Suite 907
5151 Beltline
Dallas, TX 75240

NORTH PACIFIC

HI, WA, OR, ID, MT, NORTHERN CALIF,
NV (EXCEPT LAS VEGAS), W. CANADA
David Jern (415) 362-4600
McGraw-Hill Publications
425 Battery St.
San Francisco, CA 94111

Bill McAfee (415) 964-0624

McGraw-Hill Publications
1000 Elwell Court - Suite 225
Palo Alto, CA 94303

WEST COAST SURPLUS AND RETAIL ACCOUNTS

Tom Harvey (805) 964-8577
3463 State St. - Suite 256
Santa Barbara, CA 93105

SOUTH PACIFIC

Karen Niles (213) 480-5243, 487-1160
McGraw-Hill Publications
3333 Wilshire Boulevard #407
Los Angeles, CA 90010

Southern CA, AZ, NM, LAS VEGAS

Page Goodrich (714) 557-6292
McGraw-Hill Publications
3301 Red Hill Ave
Building #1, Suite 222
Costa Mesa, CA 92626

Post Card Mailings

National
Bradley Browne (603) 924-9281
BYTE Publications
70 Main Street
Peterborough, N.H. 03458

International Advertising Sales Representatives:

Mr. Hans Csokor
Publimedia
Reisnerstrasse 61
A-1037 Vienna, Austria

Mrs. Gurit Gepner
McGraw-Hill Publishing Co.
115 Yosephal St.
Bat Yam, Israel
866 561 321 39

Mr. Fritz Krusebecker
McGraw-Hill Publishing Co.
Liebigstrasse 27C
D-6000 Frankfurt/Main 1
West Germany
72 01 81

Mrs. Maria Sarmiento
Pedro Teixeira B. Off. 320
Iberia Mart 1
Madrid 4, Spain
45 52 891

Mr. Andrew Karnig
Andrew Karnig & Associates
Kungsholmsgatan 10
112 27 Stockholm, Sweden
08 51 68 70

Mr. Michael Sales
McGraw-Hill Publishing Co.
17 rue Georges Bizet
F 75116 Paris
France
720 33 42

Mr. Arthur Scheffer
McGraw-Hill Publishing Co.
34 Dover St.
London W1X 3RA
England
01 493 1451

Mr. Elio Gonzaga
McGraw-Hill Publishing Co.
Via Baracchini 1
20123 Milan, Italy
86 90 617

Seavex Ltd.
05-49/50 Tanglin Shopping
Center
19 Tanglin Rd. Singapore 1024
Republic of Singapore

Seavex, Ltd.
Room 102, Yu Yuet Lai Bldg.
43-55 Wyndham St. Central
Hong Kong

Akira Nagata
Nikkei/McGraw-Hill Publishing
Co.
1-1 Ogawamachi
Kanda
Chiyoda-Ku
Tokyo 101, Japan

History will record as a profound irony
that the most powerful word processing package
ever created for the IBM® Personal Computer
wasn't created by IBM.

LEADING EDGE.®

Leading Edge Products Inc., Fortune 1300 Division, 21 Highland Circle, Needham Heights, Mass. 02194 (800) 343-3436 (617) 449-6762
Headquarters and Retail Division, 225 Turnpike Street, Canton, Mass. 02021 (800) 343-6833 (617) 828-8150

*IBM is a registered trademark of International Business Machines Corporation.

Circle 266 on inquiry card.

MAJOR NEW PRODUCT ANNOUNCEMENT!
**RADIO SHACK'S MOST POWERFUL
 COLOR COMPUTER
 EVER!**

64K Extended BASIC
 TRS-80® Color Computer

399.95
 26-3003
 Less TV

Only \$28 Per Month
 On CitiLine Credit



The Heart of a Sophisticated, Disk-Based Color Graphics System

Perfect System for the Advanced Programmer. Double your programming power with our new TRS-80 Color Computer—now with 64,000 characters of memory! There's even a new electric typewriter-quality keyboard in a compact, white case. With this professional computer, you can access 32K memory and create detailed charts, diagrams and animation using the powerful, built-in Extended BASIC language—or experience the full 64K with our new, advanced programming tools!

Comprehensive Disk Operating System. Add a new Color Computer Disk Drive (26-3029, \$399.95) and you can step up to our new OS-9 with Editor/Assembler (26-3030, \$69.95). OS-9 is a real-time disk operating system that accesses the entire memory of the 64K Color Computer. It supports multi-tasking, and offers 40 utility programs, as well as a full-featured editor/assembler to let you create assembly language programs with speed and efficiency. System programs are written in assembly language, except for some utilities written in the C language.

Professional Computing at a Low Cost. This superb TRS-80 trio lets you enjoy unsurpassed power and flexibility in assembly language and color graphics programming. The complete system—including the 64K Extended BASIC TRS-80 Color Computer, OS-9 operating system with editor/assembler and Color Disk Kit—is just \$869.85!

Discover a TRS-80 Color Disk System! To find out more, stop in today at your nearest Radio Shack Computer Center, participating store or dealer—and ask for a demonstration!

Radio Shack®

The biggest name in little computers®

A DIVISION OF TANDY CORPORATION

Prices apply at participating Radio Shack stores and dealers.

Circle 394 on Inquiry card.